

CONTENTS 目次

MAIN PCB (1/4).....	2
MAIN PCB (2/4).....	3
MAIN PCB (3/4).....	4
MAIN PCB (4/4).....	5
PANEL PCB	6
DISPLAY PCB.....	7
PHONE PCB	8
ANALOG PCB (1/6).....	9
ANALOG PCB (2/6).....	10
ANALOG PCB (3/6).....	11
ANALOG PCB (4/6).....	12
ANALOG PCB (5/6).....	13
ANALOG PCB (6/6).....	14
XLR123 / XLR4 PCB	15

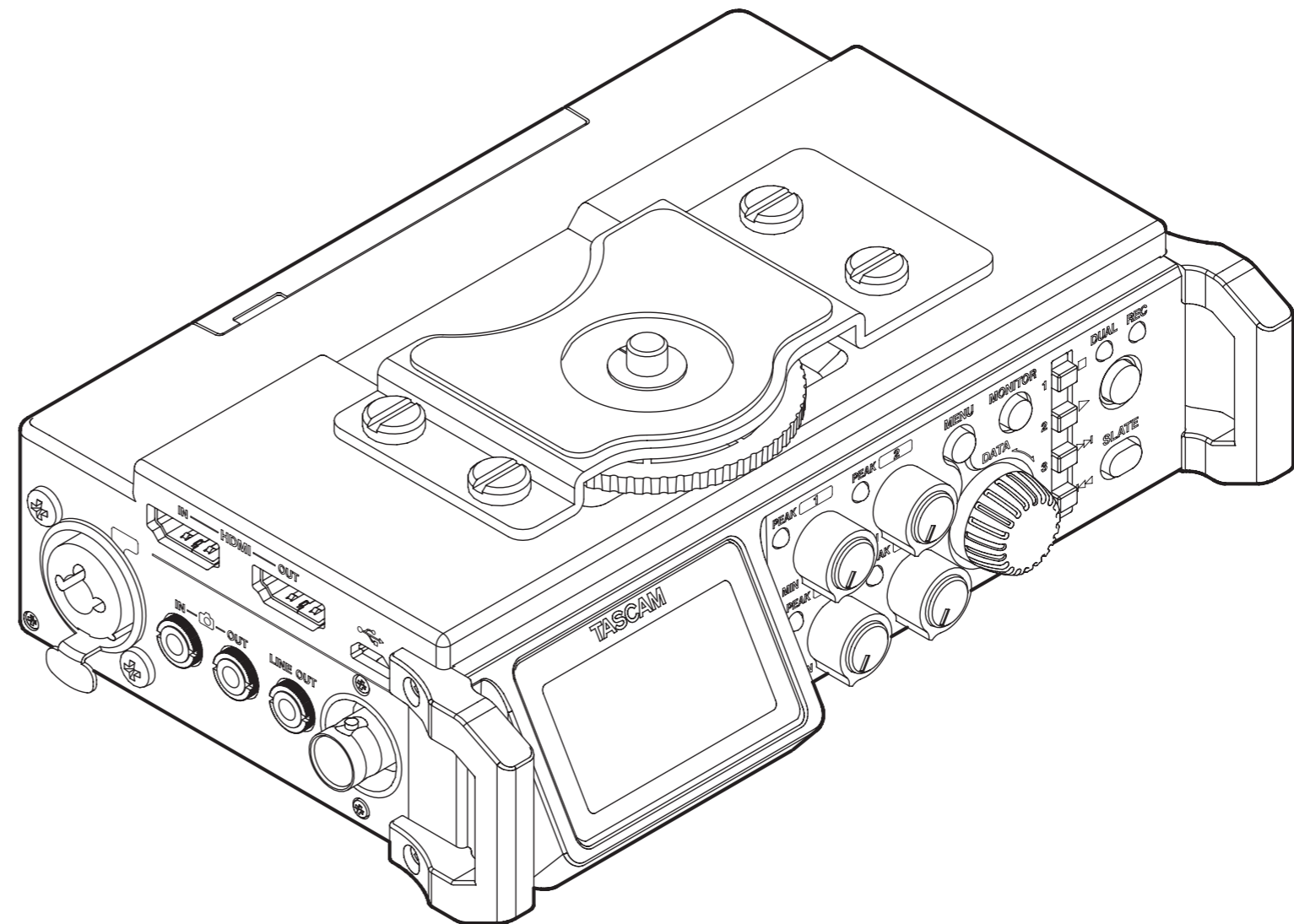

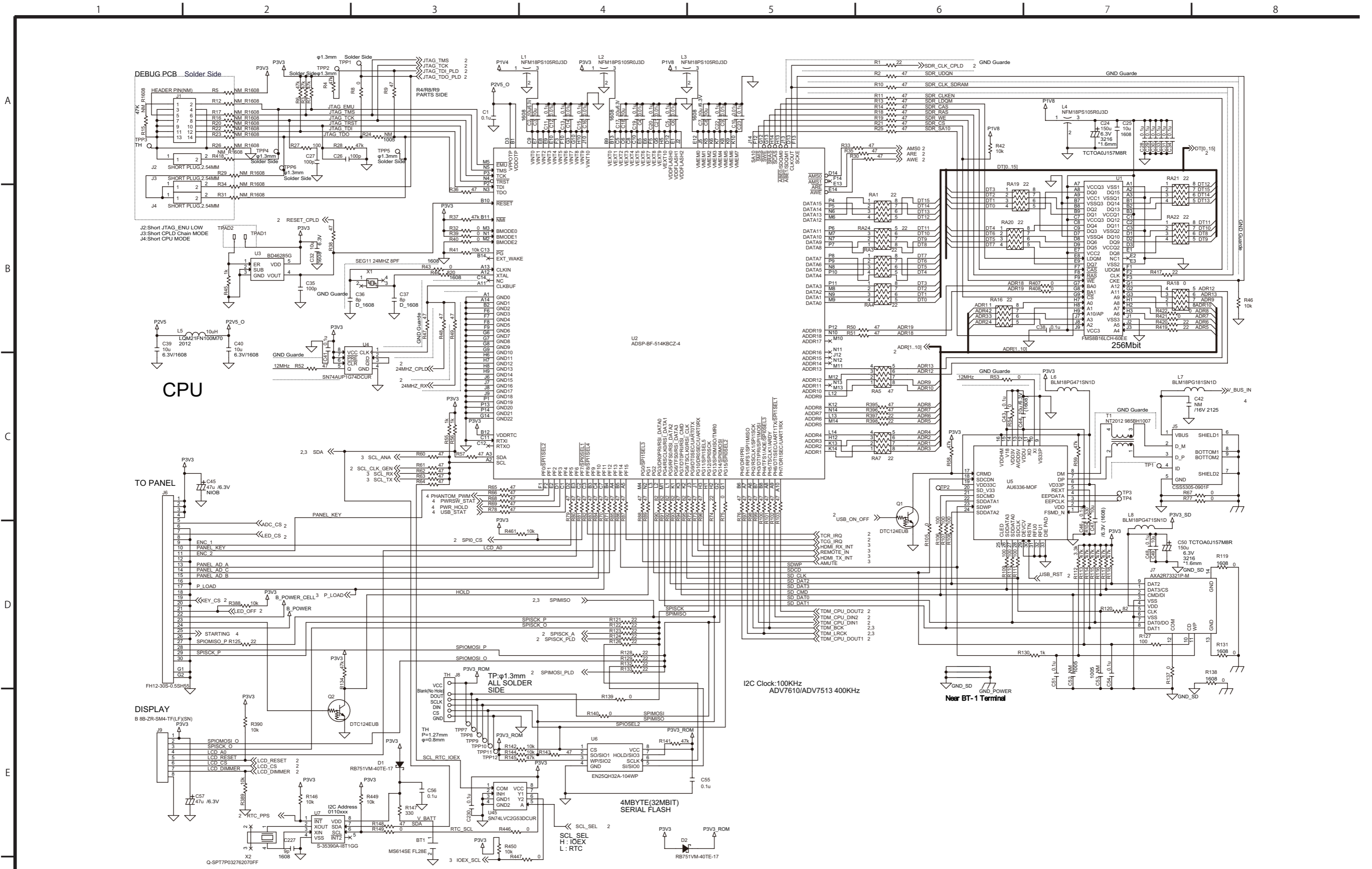

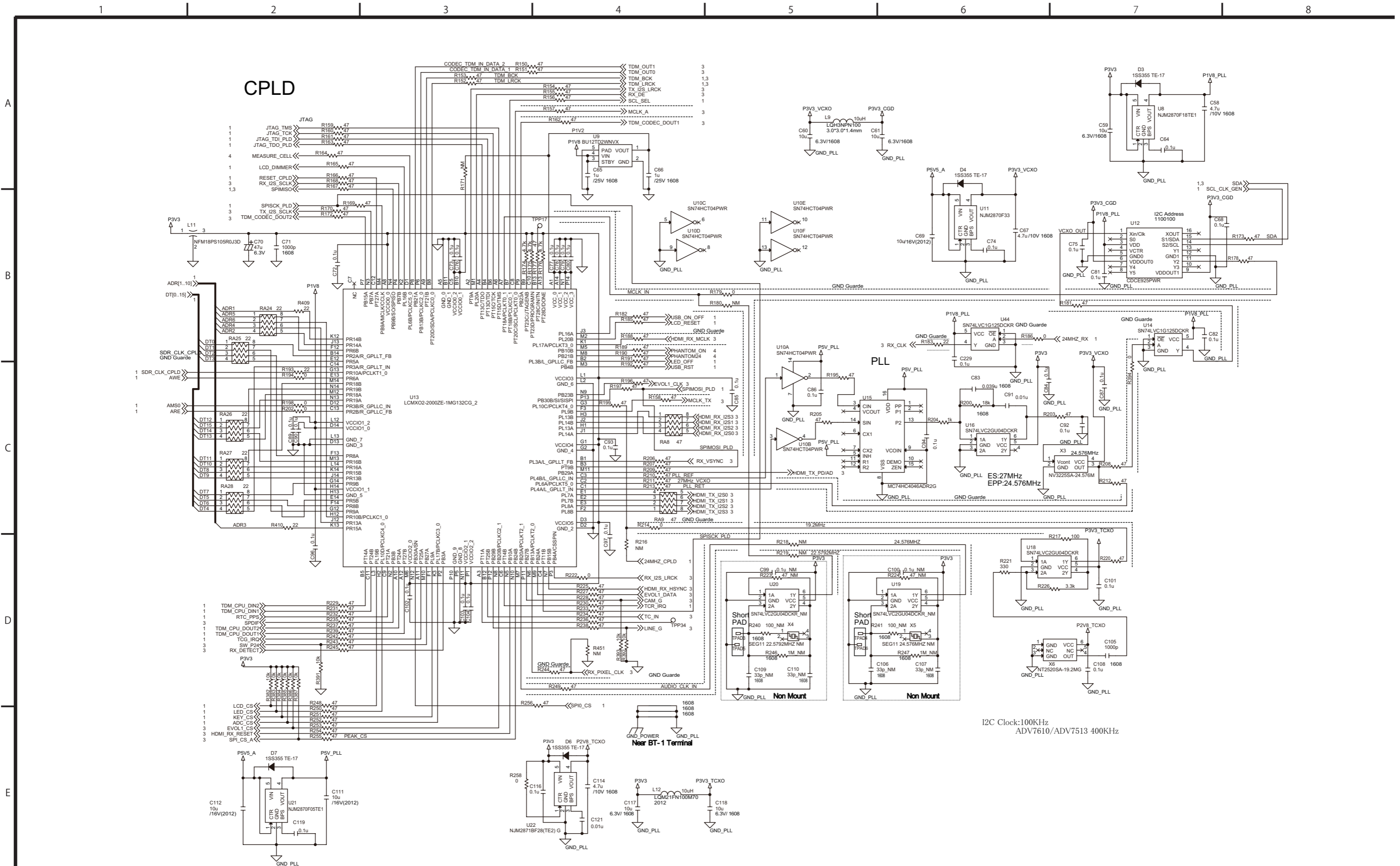

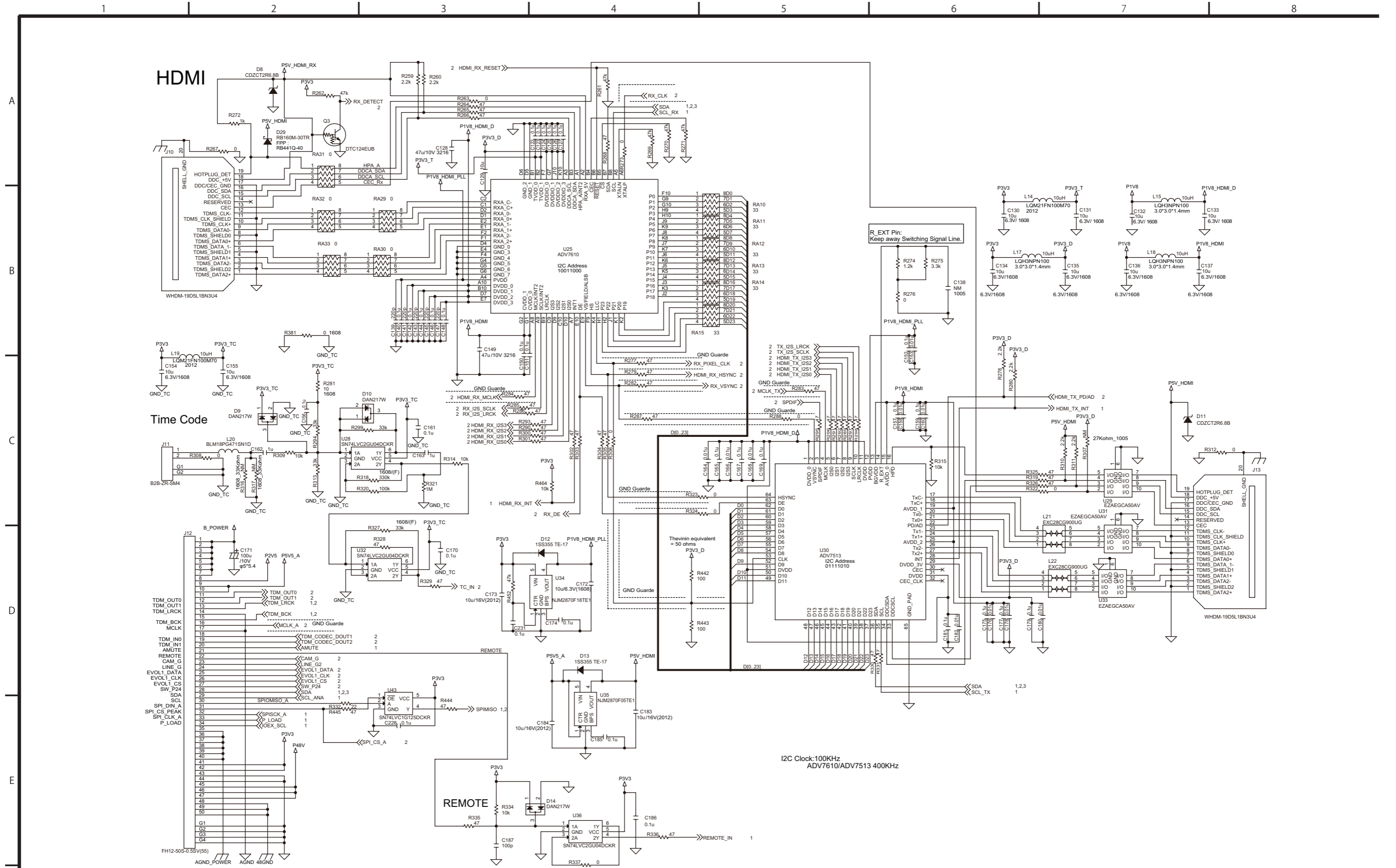

1 2 3 4 5 6 7 8

A

B

C

D

E

POWER

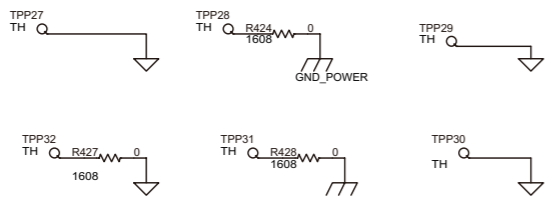
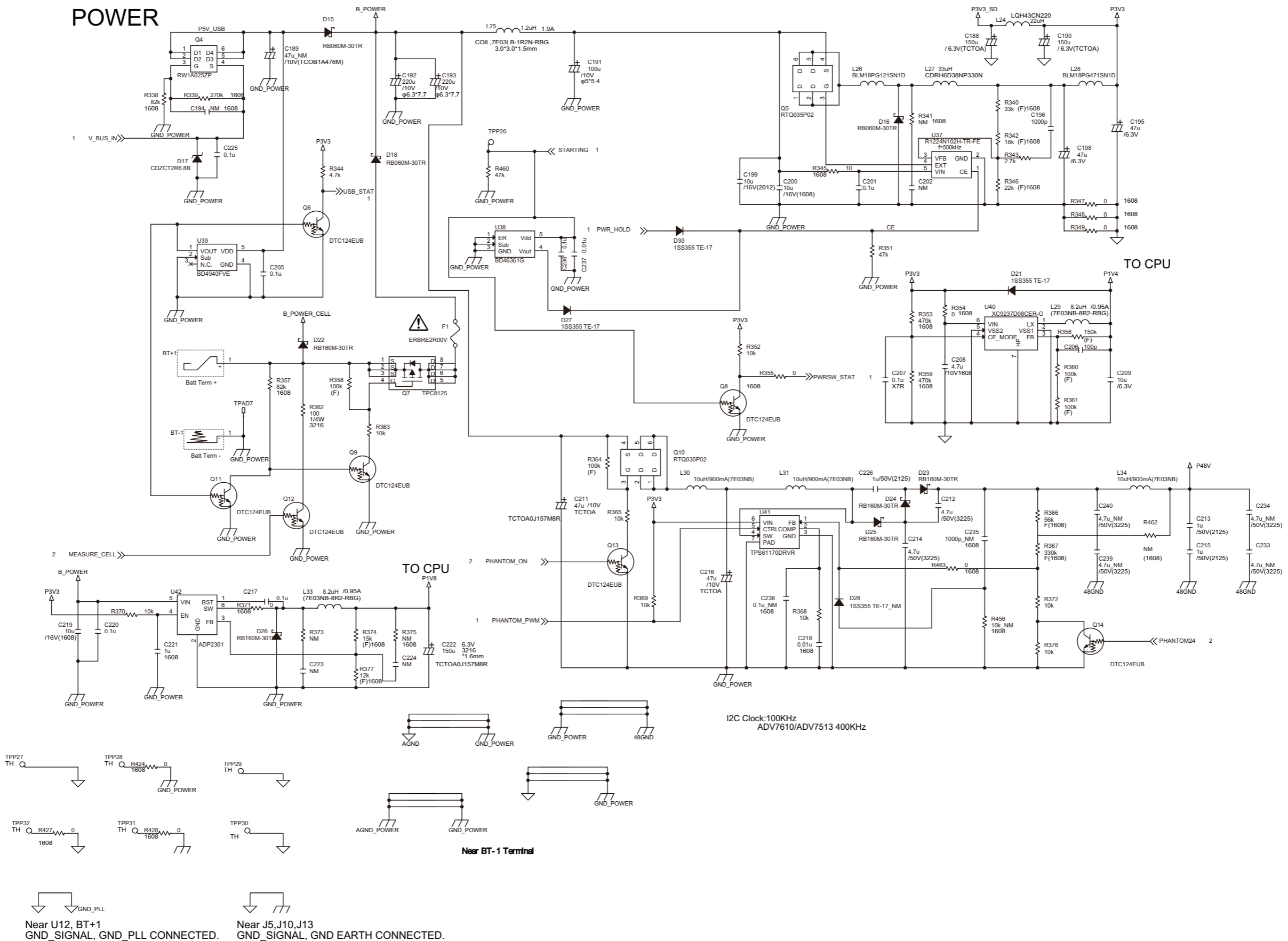

I2C Clock:100KHz
ADV7610/ADV7513 400KHz

1 2 3 4 5 6 7 8

A

B

C

D

E

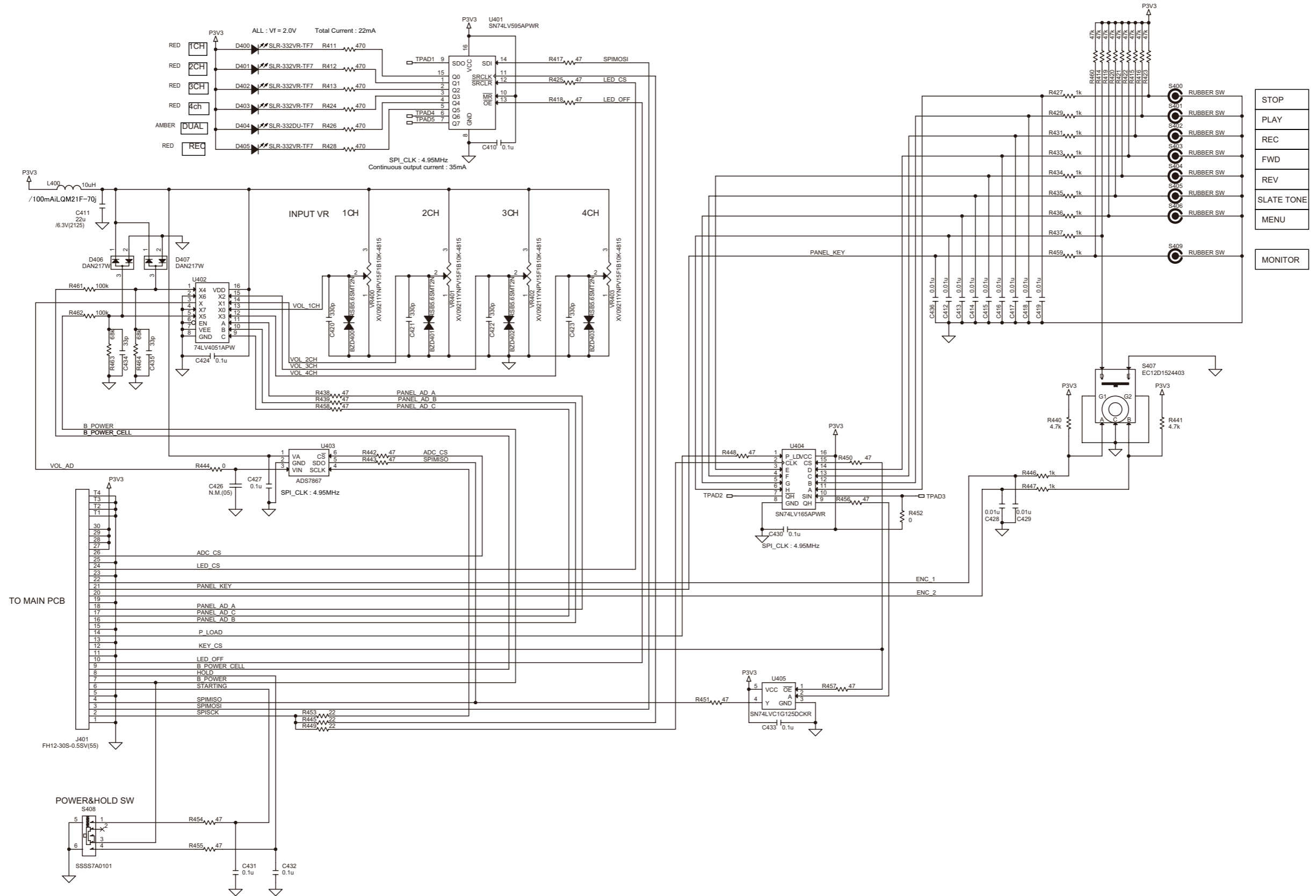

1 2 3 4 5 6 7 8

A

B

C

D

E

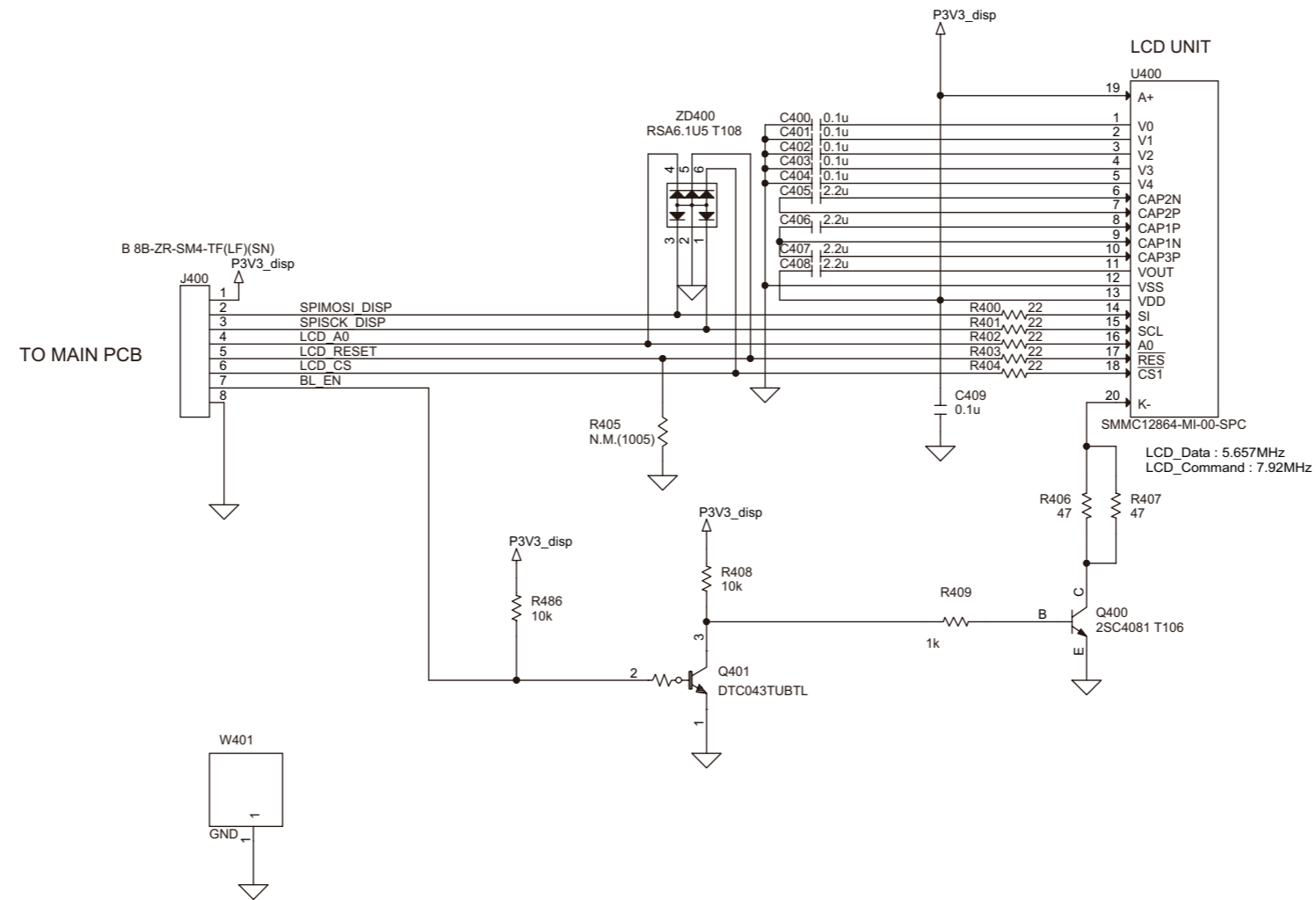

1 2 3 4 5 6 7 8

A

B

C

D

E

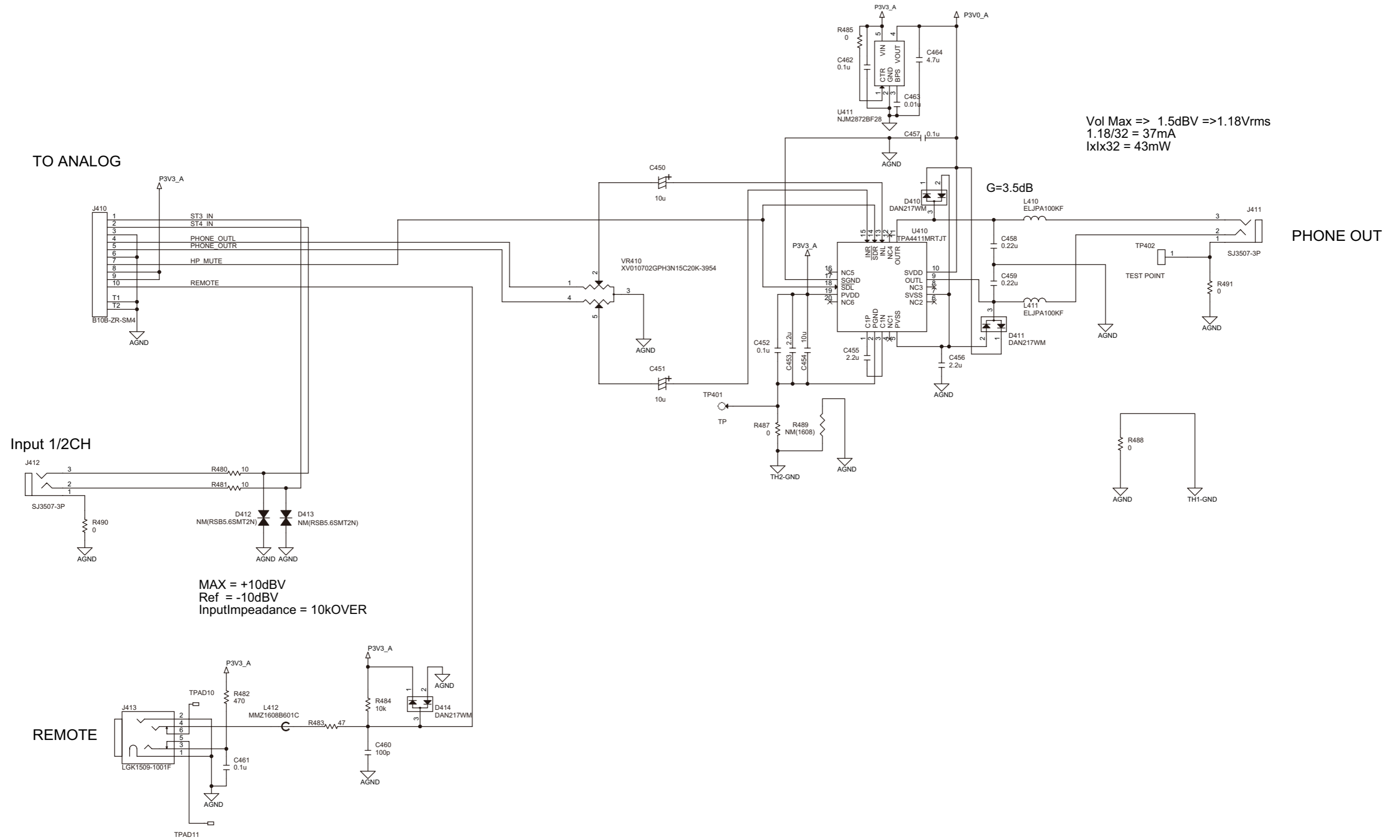

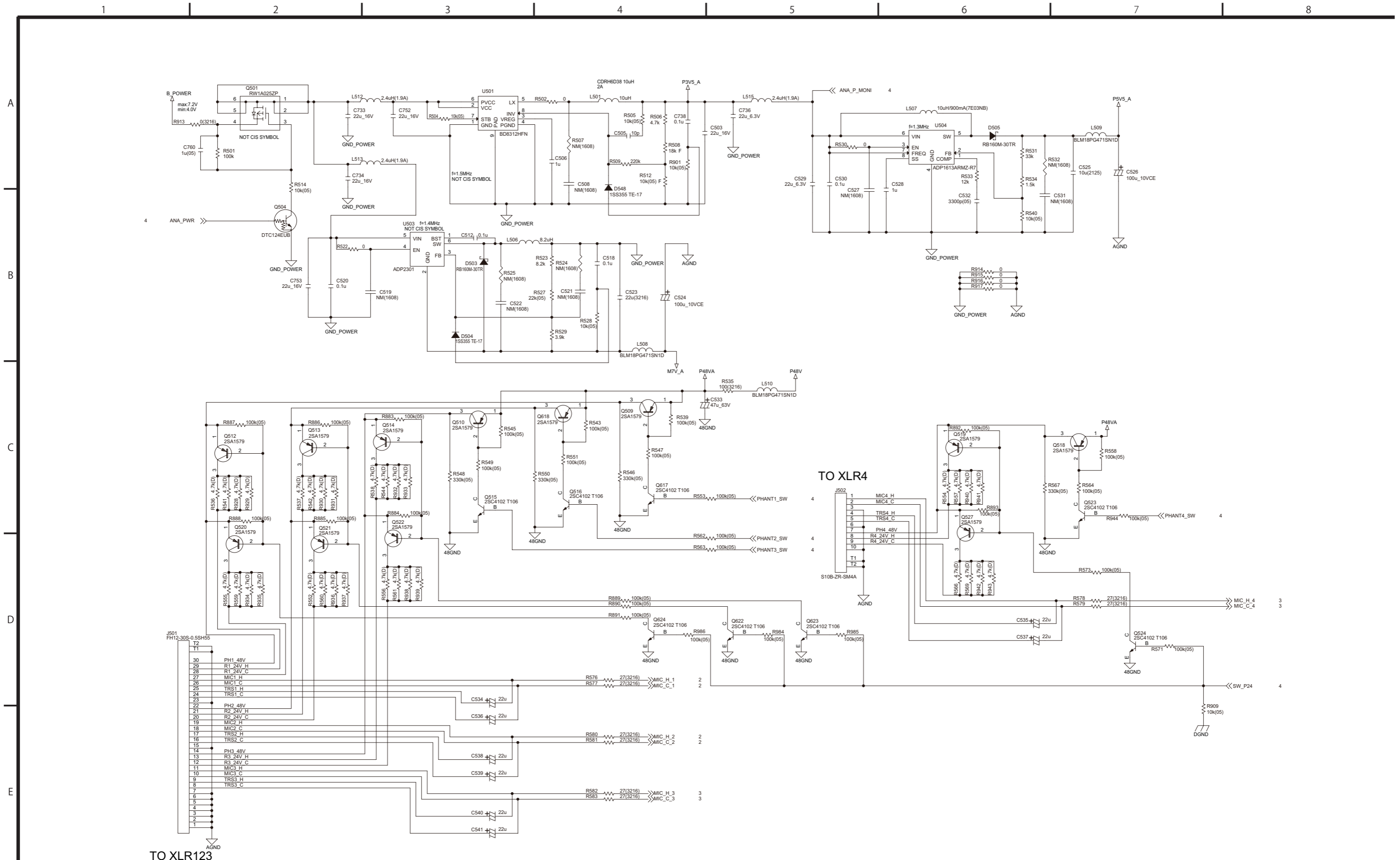

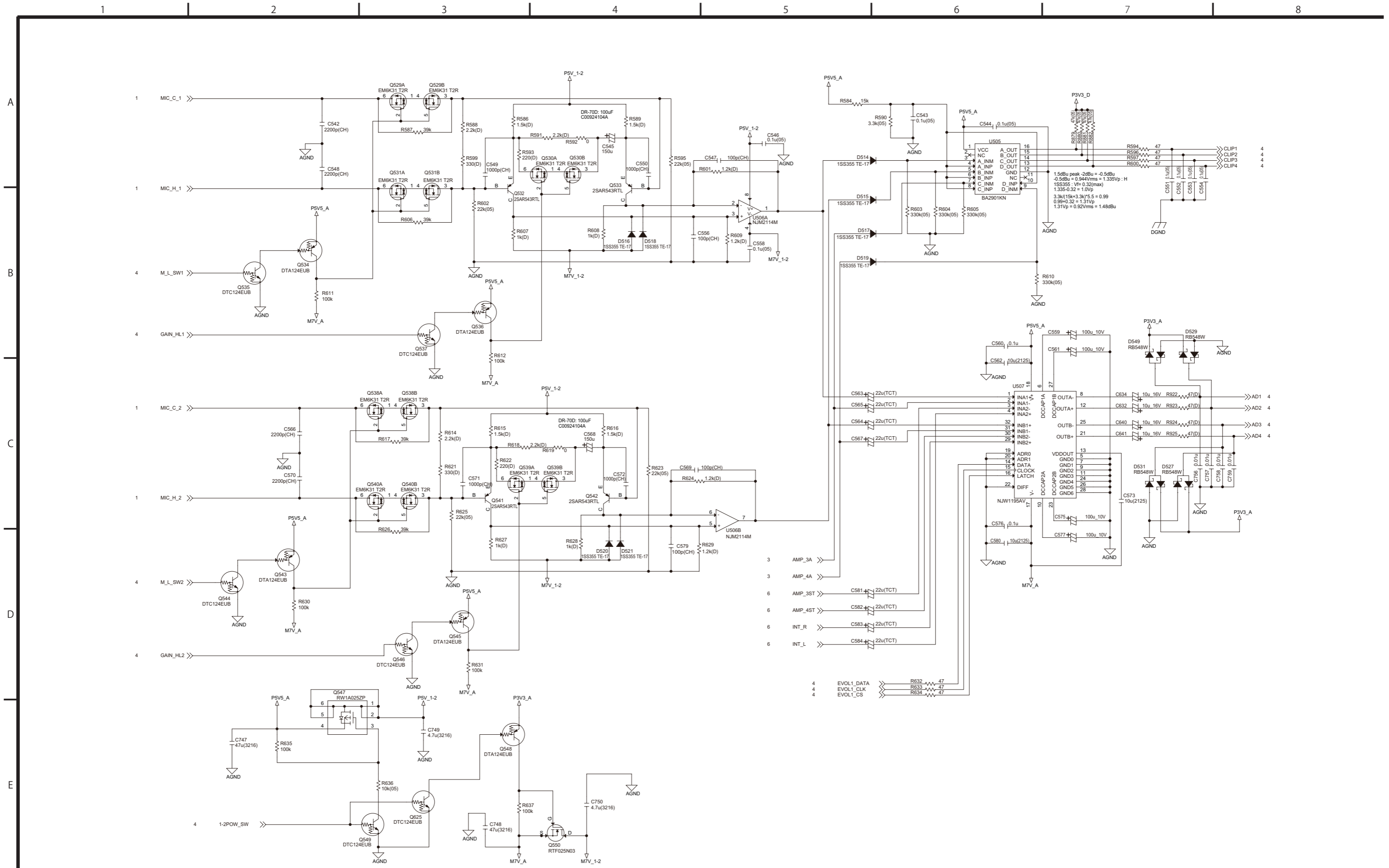

1 2 3 4 5 6 7 8

A

B

C

D

E

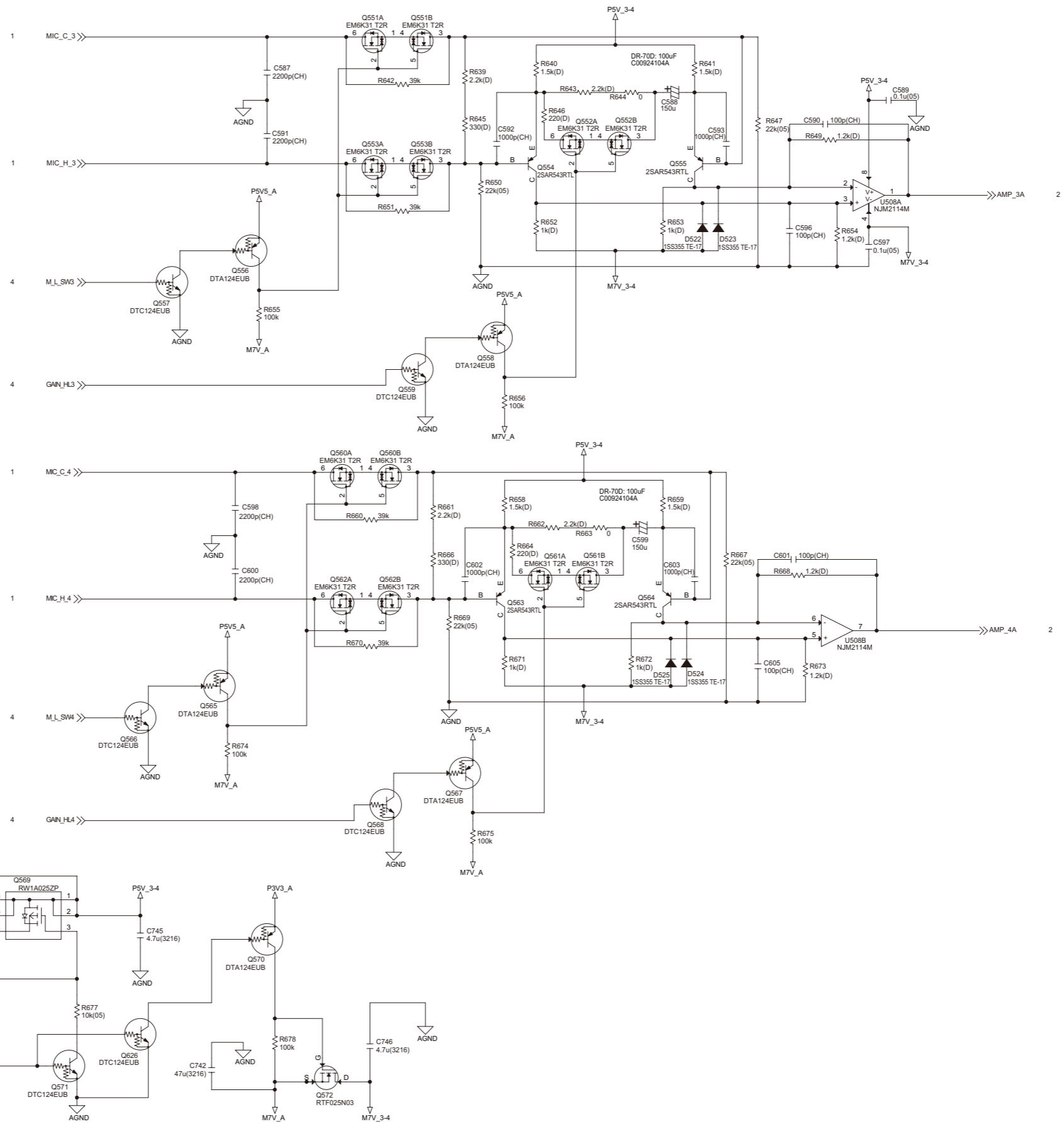

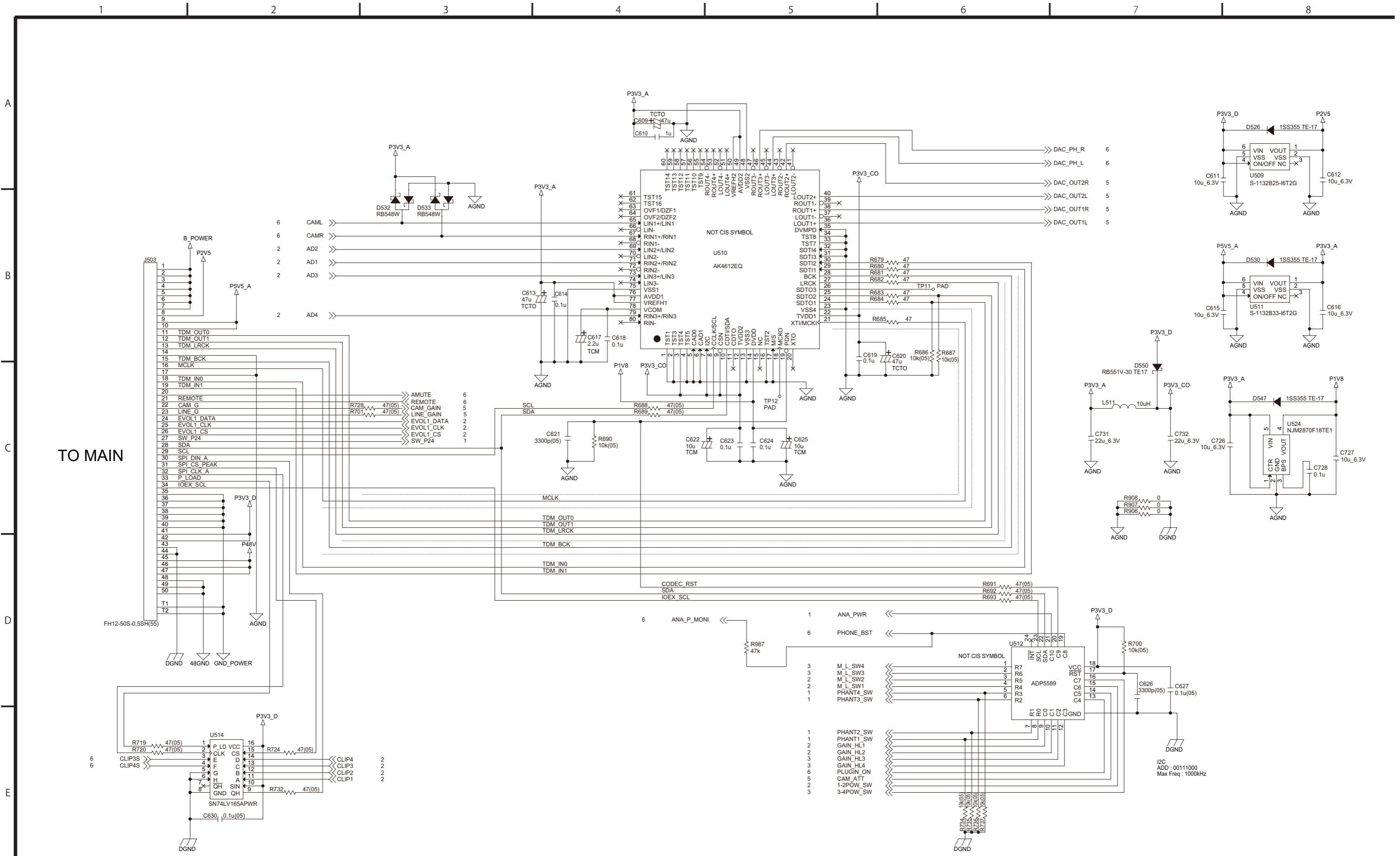

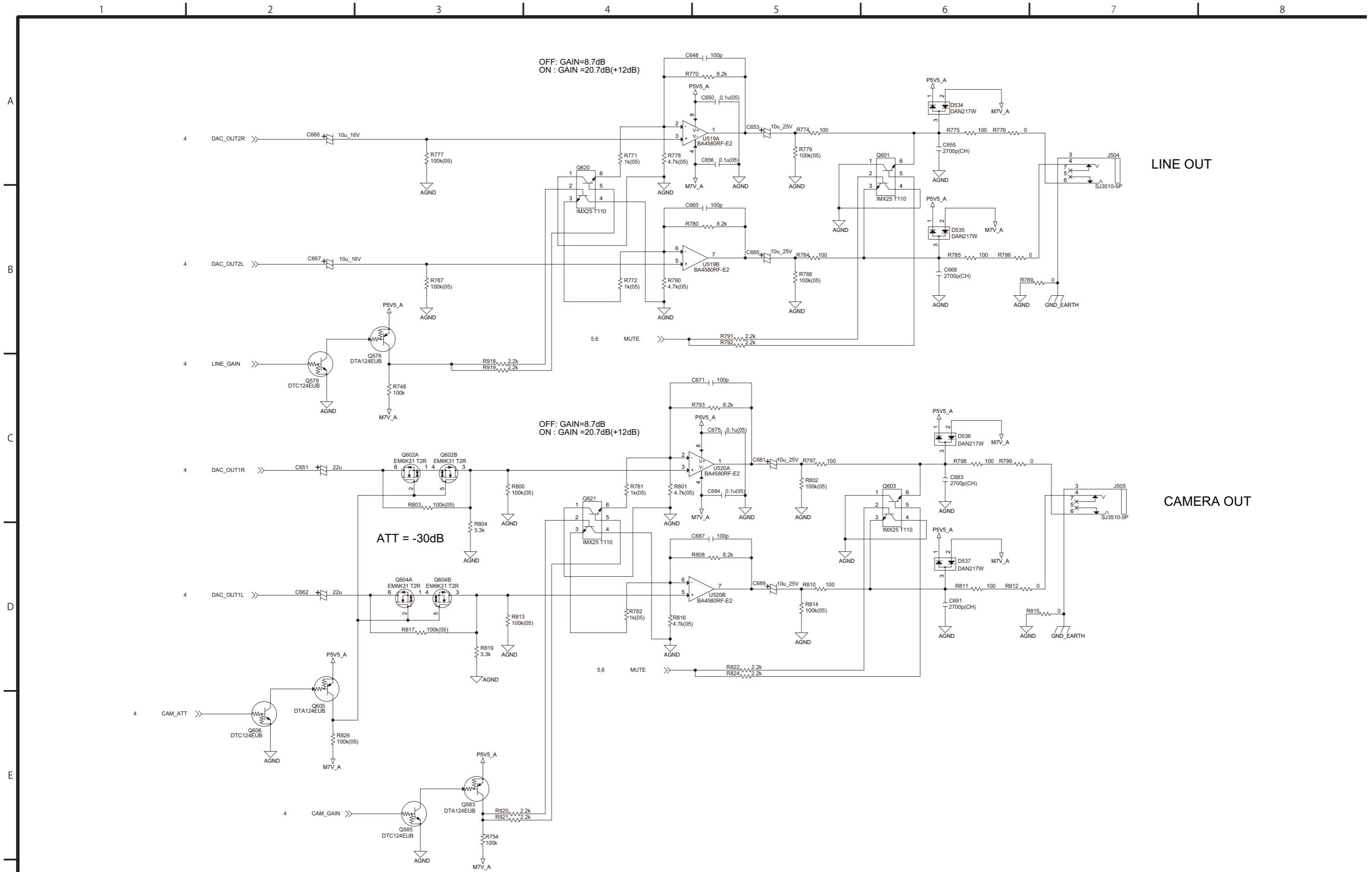

LINE OUT

CAMERA OUT

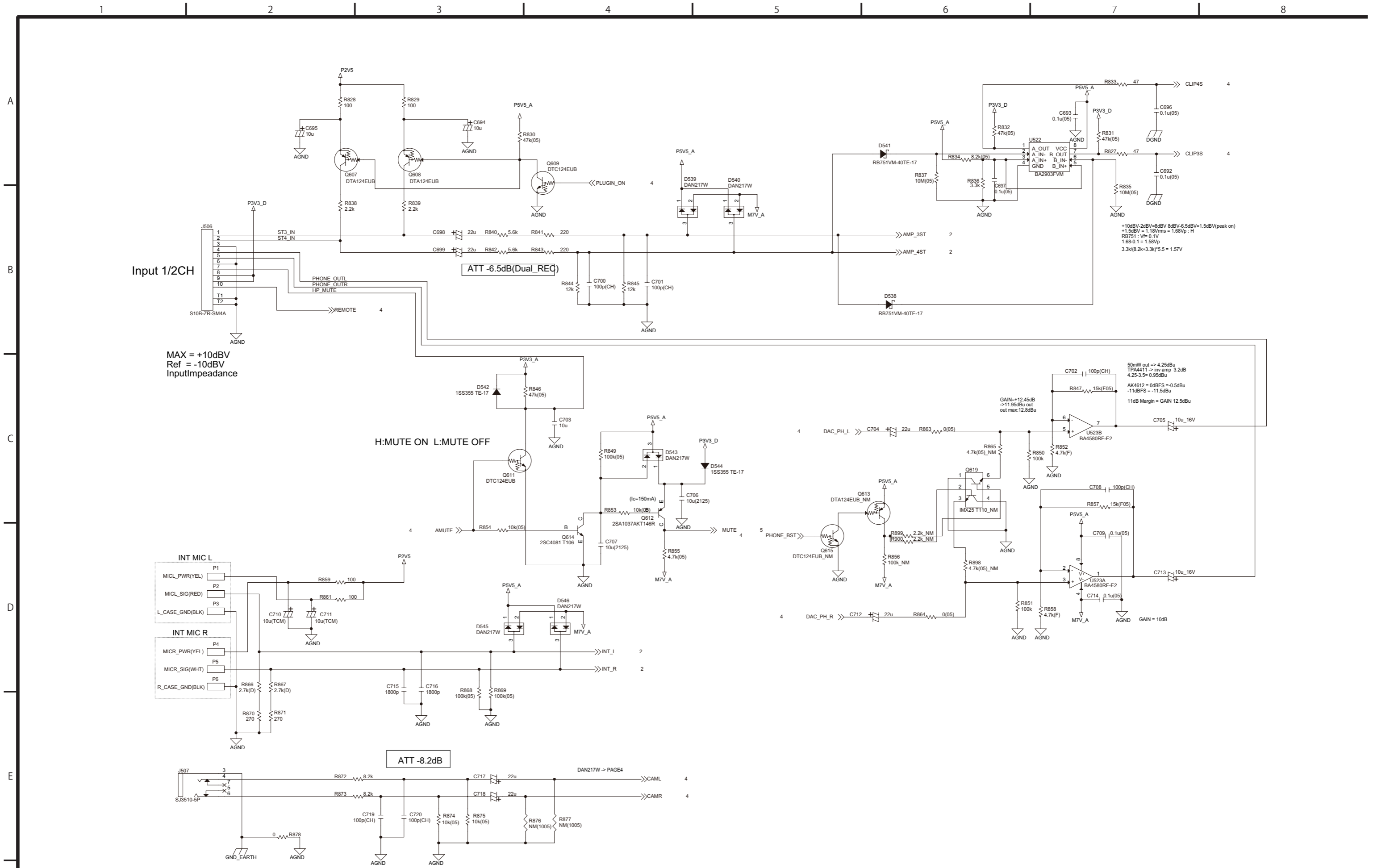

1 2 3 4 5 6 7 8

A

B

C

D

E

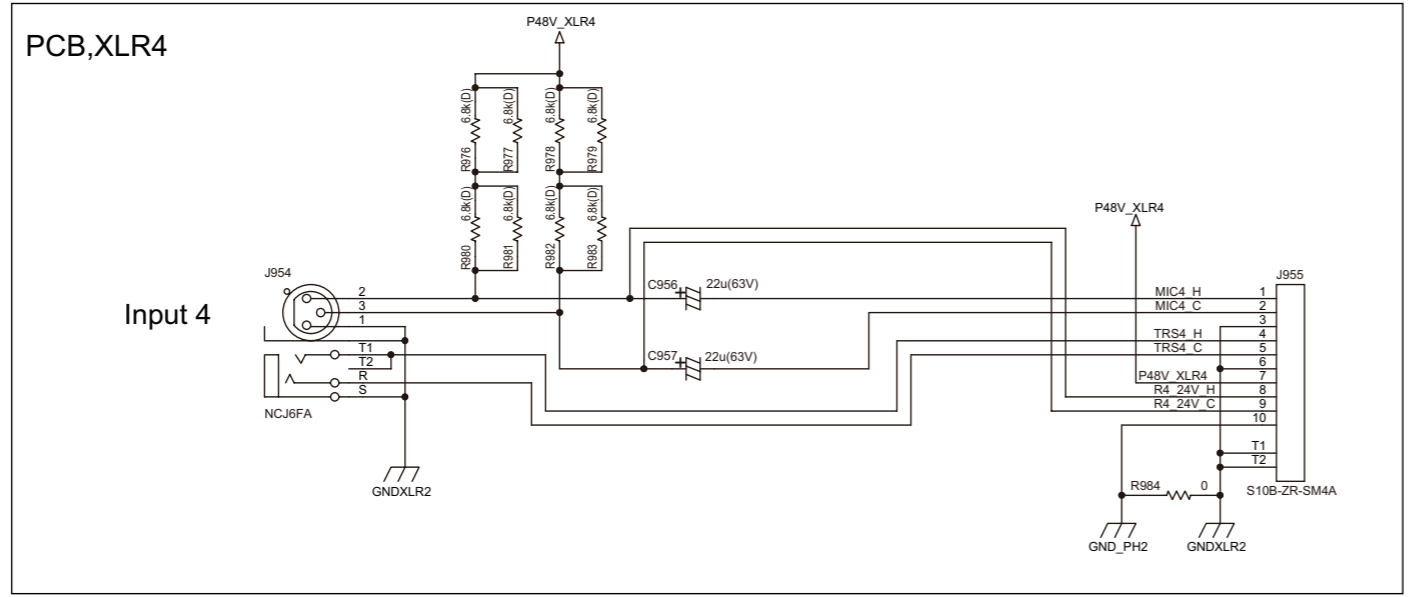
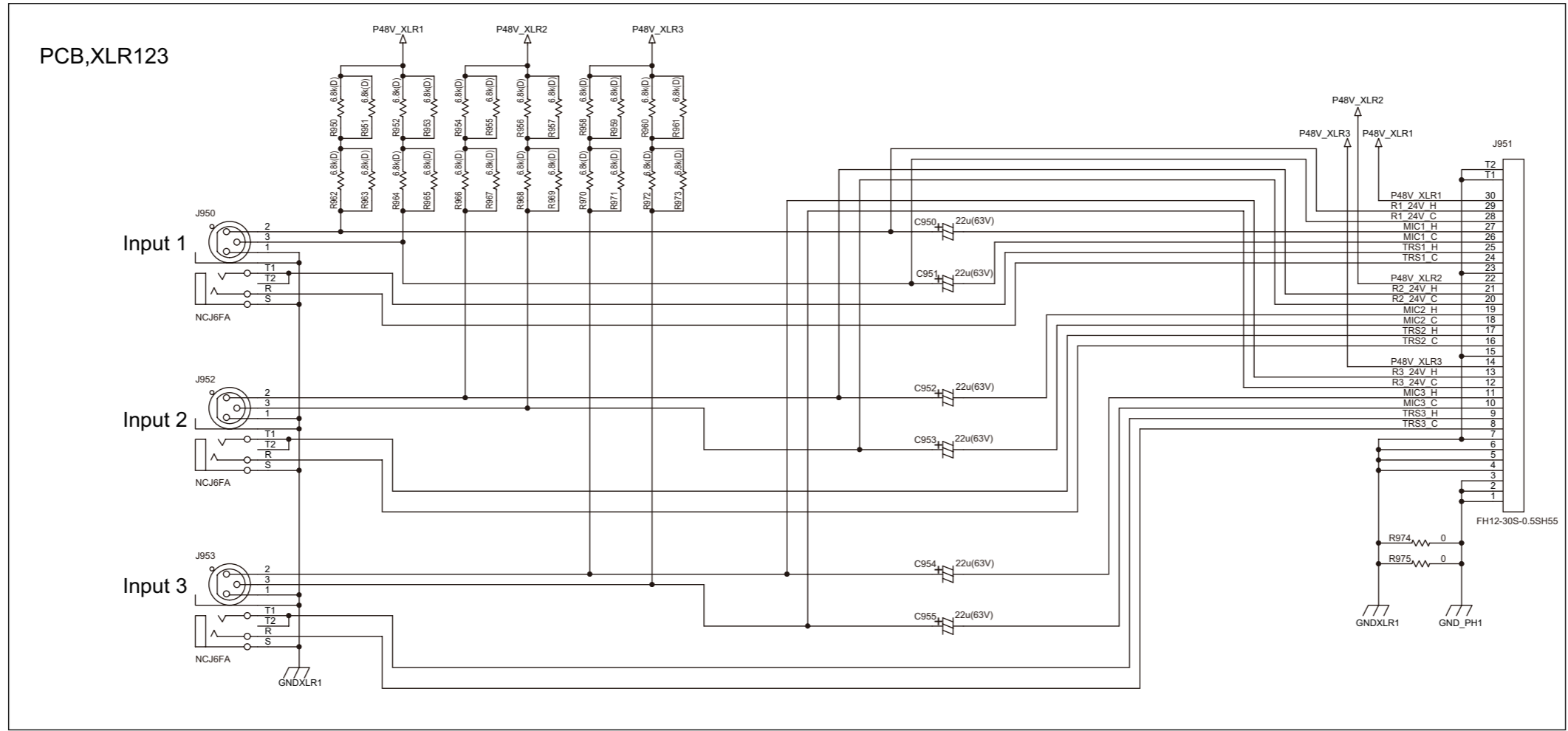

FROM ANA

FROM ANA