

TASCAM[®]
TEAC PROFESSIONAL

SERVICE MANUAL

LA-80MKII/81MKII

Unbalanced / Balanced Line Converter

CONTENTS

1. Specifications	2
2. Adjustment and Checks (LA-80MKII)	4
3. Adjustment and Checks (LA-81MKII)	4
4. Block Diagram	6
5. Level Diagram	7
6. Exploded Views and Parts List	8
7. PC Boards and Parts List	10
8. Included Accessories	14

目次

1. 仕様	2
2. 調整と確認 (LA-80MKII)	4
3. 調整と確認 (LA-81MKII)	4
4. ブロックダイアグラム	6
5. レベルダイアグラム	7
6. 分解図とパーツリスト	8
7. 基板図とパーツリスト	10
8. 付属品	14

INSTRUCTIONS FOR SERVICE PERSONNEL

BEFORE RETURNING APPLIANCE TO THE CUSTOMER, MAKE LEAKAGE-CURRENT OR RESISTANCE MEASUREMENTS TO DETERMINE THAT EXPOSED PARTS ARE ACCEPTABLY INSULATED FROM THE SUPPLY CIRCUIT.

1. Specifications

仕様

Inputs and Outputs

UNBALANCED TO BALANCED (LA-80MKII)

- Inputs (8 unbalanced RCA pin jacks)

Input impedance	23 k Ω (when all INPUT LINK switches are OFF)
	2.8 k Ω (when all INPUT LINK switches are ON)
Nominal input level	-10 dBV \pm 1 dB
Maximum input level	+4.8 dBV
Indicator detection level (unbalanced input)	-38 dBV or more (OUTPUT LEVEL switch set to +4 dB or -20 dB)
- Outputs (8 balanced XLR type connectors)
(Pin assignment: 1 = ground, 2 = hot, 3 = cold)

Output impedance	94 Ω
Nominal load impedance	10k Ω
Minimum load impedance	600 Ω
Nominal output level	+4 dBu \pm 1 dB (OUTPUT LEVEL switch set to +4 dB)
	-20 dBu \pm 1 dB (OUTPUT LEVEL switch set to -20 dB)
Maximum output level	+23 dBu

BALANCED TO UNBALANCED (LA-81MKII)

- Inputs (8 balanced XLR type connectors)
(Pin assignment: 1 = ground, 2 = hot, 3 = cold)

Input impedance	54 k Ω (when all INPUT LINK switches are OFF)
	6.7 k Ω (when all INPUT LINK switches are ON)
Nominal input level	+4 dBu \pm 1 dB (INPUT LEVEL switch set to +4 dB)
	-20 dBu \pm 1 dB (INPUT LEVEL switch set to -20 dB)
Maximum input level	+30 dBu (INPUT LEVEL switch set to +4 dB)
	+8 dBu (INPUT LEVEL switch set to 20 dB)
Indicator detection level (balanced input)	-24 dBu or more (INPUT LEVEL switch set to +4 dB)
	-48 dBu or more (INPUT LEVEL switch set to -20 dB)

定格

UNBALANCED TO BALANCED (LA-80MKII)

- 入力 (アンバランス、RCA ピン・ジャック \times 8)

入力インピーダンス:	23k Ω (INPUT LINK スイッチ \Rightarrow オールOFF)
	2.8k Ω (INPUT LINK スイッチ \Rightarrow オールON)
規定入力レベル:	-10dBV (\pm 1dB)
最大入力レベル:	+4.8dBV
インジケータ検出レベル: (UNBALANCED INPUT)	-38dBV 以上 (OUTPUTLEVEL スイッチ \Rightarrow + 4dB/-20dB 共通)
- 出力 (バランス、XLR タイプ・コネクター \times 8)
(端子接続: 1番=グランド、2番=ホット、3番=コールド)

出力インピーダンス:	94 Ω
規定負荷インピーダンス:	10k Ω
最小負荷インピーダンス:	600 Ω
規定出力レベル:	+4dBu (\pm 1dB) (OUTPUT LEVEL スイッチ \Rightarrow + 4dB)
	-20dBu (\pm 1dB) (OUTPUT LEVEL スイッチ \Rightarrow -20dB)
最大出力レベル:	+23dBu

BALANCED TO UNBALANCED (LA-81MKII)

- 入力 (バランス、XLR タイプ・コネクター \times 8)
(端子接続: 1番=グランド、2番=ホット、3番=コールド)

入力インピーダンス:	54k Ω (INPUT LINK スイッチ \Rightarrow オールOFF)
	6.7k Ω (INPUT LINK スイッチ \Rightarrow オールON)
規定入力レベル:	+4dBu (\pm 1dB) (INPUT LEVEL スイッチ \Rightarrow + 4dB)
	-20dBu (\pm 1dB) (INPUT LEVEL スイッチ \Rightarrow -20dB)
最大入力レベル:	+30dBu (INPUT LEVEL スイッチ \Rightarrow + 4dB)
	+8dBu (INPUT LEVEL スイッチ \Rightarrow -20dB)
インジケータ検出レベル(BALANCED INPUT):	-24dBu 以上 (INPUT LEVEL スイッチ \Rightarrow + 4dB)
	-48dBu 以上 (INPUT LEVEL スイッチ \Rightarrow -20dB)

- Outputs (8 unbalanced RCA pin jacks)

Output impedance	200 Ω
Nominal load impedance	10 kΩ
Minimum load impedance	1 kΩ
Nominal output level	-10 dBV ±1 dB
Maximum output level	+18 dBV

Performance

- TRIM range ±12 dB
- S/N ratio (nominal input and output level)
A-weight filter + 20 kHz LPF: 90 dB
(LA-80MKII) (OUTPUT LEVEL switch set to +4 dB)
(LA-80MKII) (INPUT LEVEL switch set to +4 dB)
20 Hz HPF + 20 kHz LPF: 87 dB
(LA-80MKII) (OUTPUT LEVEL switch set to +4 dB)
(LA-80MKII) (INPUT LEVEL switch set to +4 dB)
- Total harmonic distortion(1 kHz, nominal input and output level)
0.007% or less
- Frequency response(nominal input and output level)
20 Hz–100 kHz ±3 dB
- Crosstalk
-90 dB or more
(1kHz, nominal input and output level,
terminated with a 600 Ω load)

Other specifications

- Power: 100-240 V~, 50/60 Hz
- Power consumption: 6 W
- Weight: 3 kg (main unit)
- External dimensions (WxHxD):
482 x 44 x 280 mm

Dimensional drawings

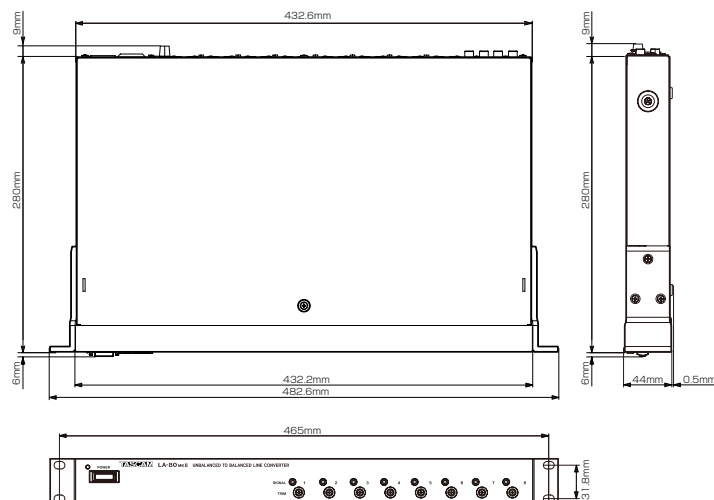

- 出力（アンバランス、RCA ピン・ジャック× 8）

出力インピーダンス：	200Ω
規定負荷インピーダンス：	10k Ω
最小負荷インピーダンス：	1k Ω
規定出力レベル：	-10dBV（± 1dB）
最大出力レベル：	+18dBV

性能

- TRIM 可変範囲： ±12dB
- S/N 比（規定入出力レベル）
A-weight filter + 20kHz LPF：90dB
(LA-80MKII) (OUTPUT LEVEL スイッチ⇒ +4dB)
(LA-81MKII) (INPUT LEVEL スイッチ⇒ +4dB)
20Hz HPF + 20kHz LPF：87dB
(LA-80MKII) (OUTPUT LEVEL スイッチ⇒ +4dB)
(LA-81MKII) (INPUT LEVEL スイッチ⇒ +4dB)
- 総合歪率（1kHz、規定入出力レベル）：
0.007%以下
- 周波数特性（規定入出力レベル）：
20Hz ~ 100kHz ±3dB
- クロストーク：
-90dB
(1kHz、規定入出力レベル、600 Ω
ターミネート)

一般

- 電源： 100 – 240V ~、50/60Hz
- 消費電力： 6W
- 重量： 3kg（本体）
- 外形寸法： 幅482 ×高さ44 ×奥行280 mm

2. Adjustment and Checks (LA-80MKII)

調整と確認

2. TRIM control knob (CH1-8)

1. Set the INPUT LINK switch to OFF and the OUTPUT LEVEL switch to the +4 position.
2. Apply a -10 dBV signal to UNBAL IN and adjust the TRIM knob so that the BAL OUT level is +4 dBu.
3. When the TRIM knob is set to the maximum and minimum positions, the output level with reference to +4 dBu should vary as follows.

Max.: +14 dB \pm 2 dB

Min.: -14 dB \pm 2 dB

2. OUTPUT LEVEL switch

With the TRIM knob adjusted to the reference level position, apply a -10 dBV signal to UNBAL IN and set the OUTPUT LEVEL switch to the -20 dB position. At this time, the BAL OUT level should be -20 dBu \pm 1 dB.

3. INPUT LINK switches

1. Apply a -10 dBV signal to CH1 UNBAL IN. Under this condition, Confirm that CH2 UNBAL OUT does not output a signal when the CH2 INPUT LINK switch is OFF and outputs a signal when the switch is ON.
2. Similarly confirm the CH3 BAL OUT signal (the CH3 INPUT LINK switch should be set to ON during this check).
3. Similarly confirm the CH4 to CH8 BAL OUT signal (the CH4 to CH8 INPUT LINK switches should be set to ON during this check).

4. Detection levels of input signal indicator LEDs

1. Set the LED switch on the rear panel to ON.
2. Set the INPUT LINK switch to OFF and the OUTPUT LEVEL switch to the +4 position.
3. Apply a 1 kHz, -38 dBV or higher-level signal to CH1 BAL IN and confirm that the CH1 LED on the front panel lights up.
4. Similarly confirm that the corresponding front panel LED lights up with each of CH2 to CH8.
5. Set the INPUT LINK switch to OFF and the OUTPUT LEVEL switch to the -20 position.
6. Apply a 1 kHz, -38 dBV or higher-level signal to CH1 UNBAL IN and confirm that the CH1 LED on the front panel lights up.
7. Similarly confirm that the corresponding front panel LED lights up with each of CH2 to CH8.

1. TRIMつまみ (CH1~8)

1. INPUT LINKスイッチをOFF、OUTPUT LEVELスイッチを+4側にセットする。
2. UNBAL INに-10dBVの信号を入力し、BAL OUTの出力レベルが+4dBuになる様にTRIMつまみを調整する。
3. TRIMつまみを最大、最小にセットした時、出力レベルは+4dBuを基準にして各々、次の様に変化すること。

最大 +14dB \pm 2dB

最小 -14dB \pm 2dB

2. OUTPUT LEVELスイッチ

TRIMつまみが基準位置にセットされた状態で、UNBAL INに-10dBVの信号を入力しOUTPUT LEVELスイッチを-20dB側にセットした時、BAL OUTの出力レベルは-20dBu \pm 1dBであること。

3. INPUT LINKスイッチ

1. CH1のUNBAL INに-10dBVの信号を入力する。この時CH2のINPUT LINKスイッチがOFFの時CH2のUNBAL OUTに信号が出力せず、ONの時は信号が出力すること。
2. 同様にCH3のBAL OUTを確認する。(但し、CH3のINPUT LINKスイッチONであること)
3. 同様にCH4~CH8のBAL OUTを確認する。(但し、CH4~CH8のINPUT LINKスイッチONであること)

4. 入力信号インジケータLED検出レベル

1. リアパネルのLED SWをONにセットする。
2. INPUT LINKスイッチをOFF、OUTPUT LEVELスイッチを+4側にセットする。
3. CH1のBAL INに1kHz、-38dBV以上の信号を入力し、フロントパネルのCH1のLEDが点灯する事を確認する。
4. 同様に、CH2~CH8についてフロントパネルのLEDが点灯する事を確認する。
5. INPUT LINKスイッチをOFF、OUTPUT LEVELスイッチを-20側にセットする。
6. CH1のUNBAL INに1kHz、-38dBV以上の信号を入力し、フロントパネルのCH1のLEDが点灯する事を確認する。
7. 同様に、CH2~CH8についてフロントパネルのLEDが点灯する事を確認する。

3. Adjustment and Checks (LA-81MKII)

調整と確認

1. TRIM control knob (CH1-4)

1. Set the INPUT LINK switch to OFF and the INPUT LEVEL switch to the +4 position.
2. Apply a +4 dBu signal to BAL IN and adjust the TRIM knob so that the UNBAL OUT level is -10 dBV.
3. When the TRIM knob is set to the maximum and minimum positions, the output level with reference to 10 dBV should vary as follows.

Max.: +14 dB \pm 2 dB

Min.: -14 dB \pm 2 dB

2. INPUT LEVEL switch

With the TRIM knob adjusted to the reference level position, apply a -20 dBu signal to BAL IN and set the INPUT LEVEL switch to the -20 dB position. At this time, the UNBAL OUT level should be -10 dB \pm 1 dB.

3. INPUT LINK switches

1. Apply a +4 dBu signal to CH1 BAL IN. Under this condition, Confirm that CH2 UNBAL OUT does not output a signal when the CH2 INPUT LINK switch is OFF and outputs a signal when the switch is ON.
2. Similarly confirm the CH3 UNBAL OUT signal (the CH2 INPUT LINK switch should be set to ON during this check).
3. Similarly confirm the CH4 to CH8 UNBAL OUT signal (the CH4 to CH8 INPUT LINK switches should be set to ON during this check).

4. Detection levels of input signal indicator LEDs

1. Set the LED switch on the rear panel to ON.
2. Set the INPUT LINK switch to OFF and the INPUT LEVEL switch to the +4 position.
3. Apply a 1 kHz, -24 dBu or higher-level signal to CH1 BAL IN and confirm that the CH1 LED on the front panel lights up.
4. Similarly confirm that the corresponding front panel LED lights up with each of CH2 to CH8.
5. Set the INPUT LINK switch to OFF and the INPUT LEVEL switch to the -20 position.
6. Apply a 1 kHz, -48 dBu or higher-level signal to CH1 BAL IN and confirm that the CH1 LED on the front panel lights up.
7. Similarly confirm that the corresponding front panel LED lights up with each of CH2 to CH8.

1. TRIMつまみ (CH1～8)

1. INPUT LINKスイッチをOFF、INPUT LEVELスイッチを+4側にセットする。
2. BAL INに+4dBuの信号を入力し、UNBAL OUTの出力レベルが-10dBVになる様にTRIMつまみを調整する。
3. TRIMつまみを最大、最小にセットした時出力レベルは10dBVを基準にして各々、次の様に変化すること。

最大 +14dB \pm 2dB

最小 -14dB \pm 2dB

2. INPUT LEVELスイッチ

TRIMつまみが基準位置にセットされた状態で、BAL INに-20dBuの信号を入力し、INPUT LEVELスイッチを-20dB側にセットした時、UNBAL OUTの出力レベルは-10dB \pm 1dBであること。

3. INPUT LINKスイッチ

1. CH1のBAL INに+4dBuの信号を入力する。この時CH2のINPUT LINKスイッチがOFFの時CH2のUNBAL OUTに信号が出力せず、ONの時は信号が出力すること。
2. 同様にCH3のUNBAL OUTを確認する。(但し、CH2のINPUT LINKスイッチONであること)
3. 同様にCH4～CH8のUNBAL OUTを確認する。(但し、CH4～CH8のINPUT LINKスイッチONであること)

4. 入力信号インジケータLED検出レベル

1. リアパネルのLED SWをONにセットする。
2. INPUT LINKスイッチをOFF、INPUT LEVELスイッチを+4側にセットする。
3. CH1のBAL INに1kHz、-24dBu以上の信号を入力し、フロントパネルのCH1のLEDが点灯する事を確認する。
4. 同様に、CH2～CH8についてフロントパネルのLEDが点灯する事を確認する。
5. INPUT LINKスイッチをOFF、INPUT LEVELスイッチを-20側にセットする。
6. CH1のBAL INに1kHz、-48dBu以上の信号を入力し、フロントパネルのCH1のLEDが点灯する事を確認する。
7. 同様に、CH2～CH8についてフロントパネルのLEDが点灯する事を確認する。

4. Block diagram

ブロックダイアグラム

(LA-80MKII)

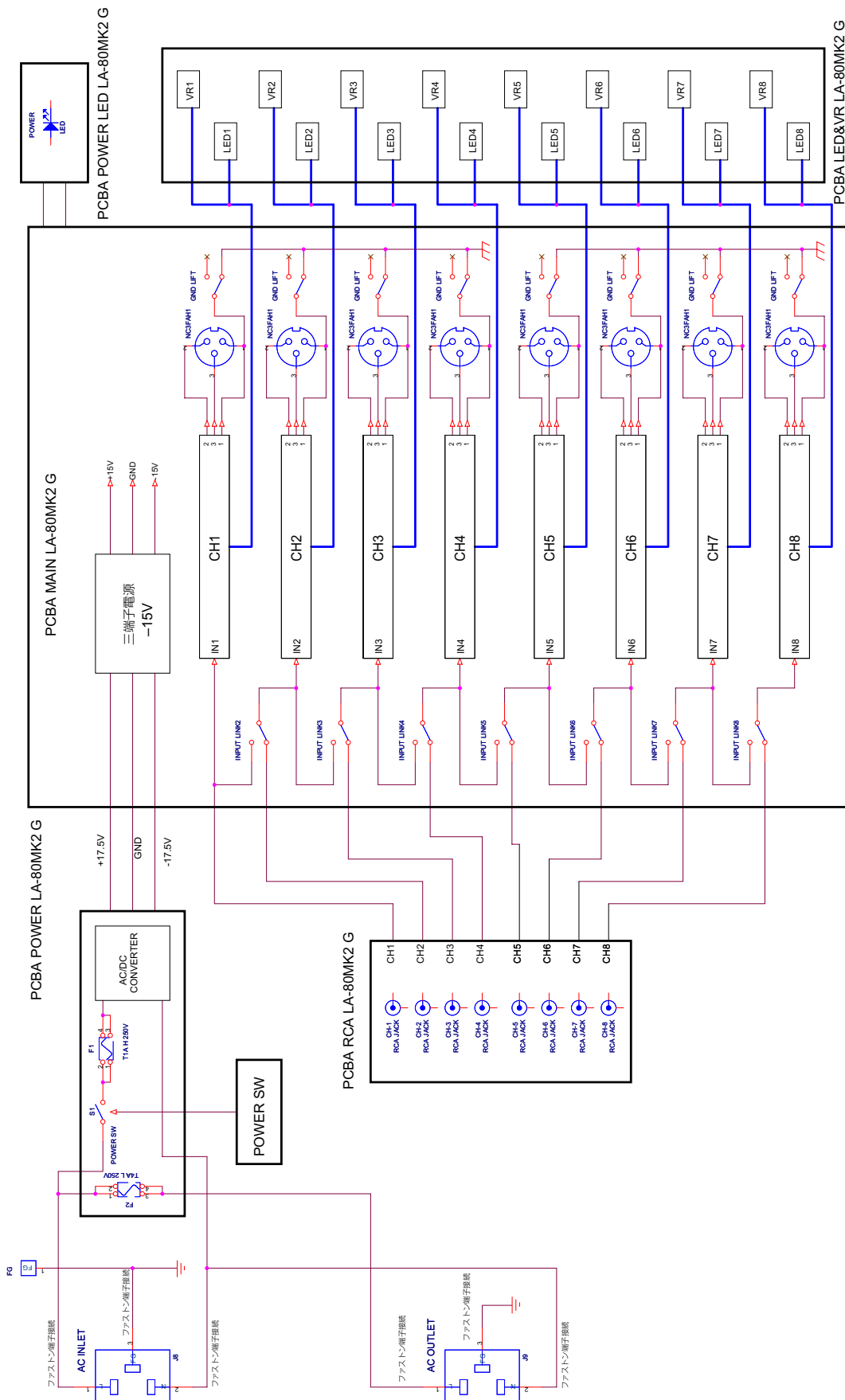

(LA-81MKII)

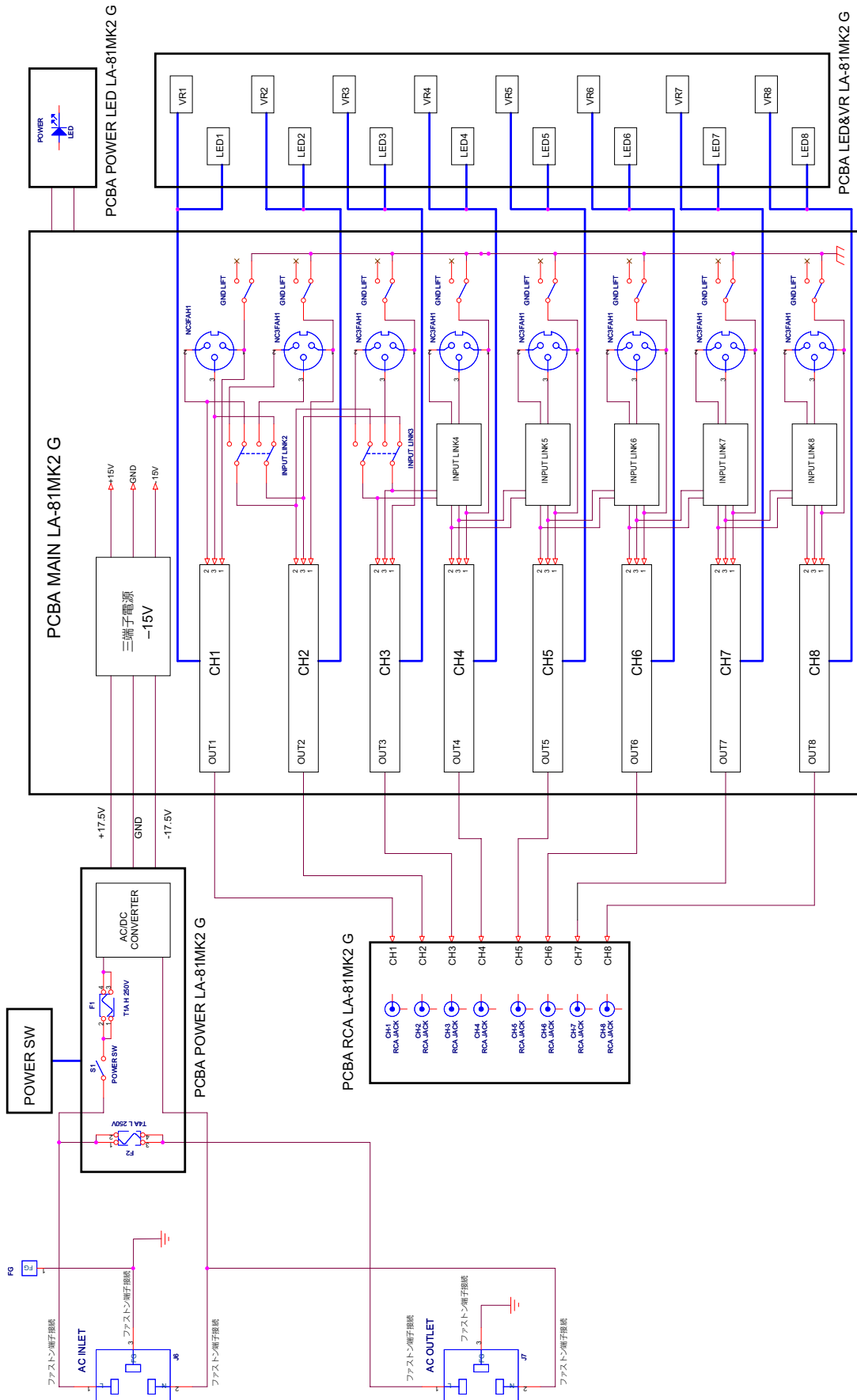

5. Level Diagram

レベルダイアグラム

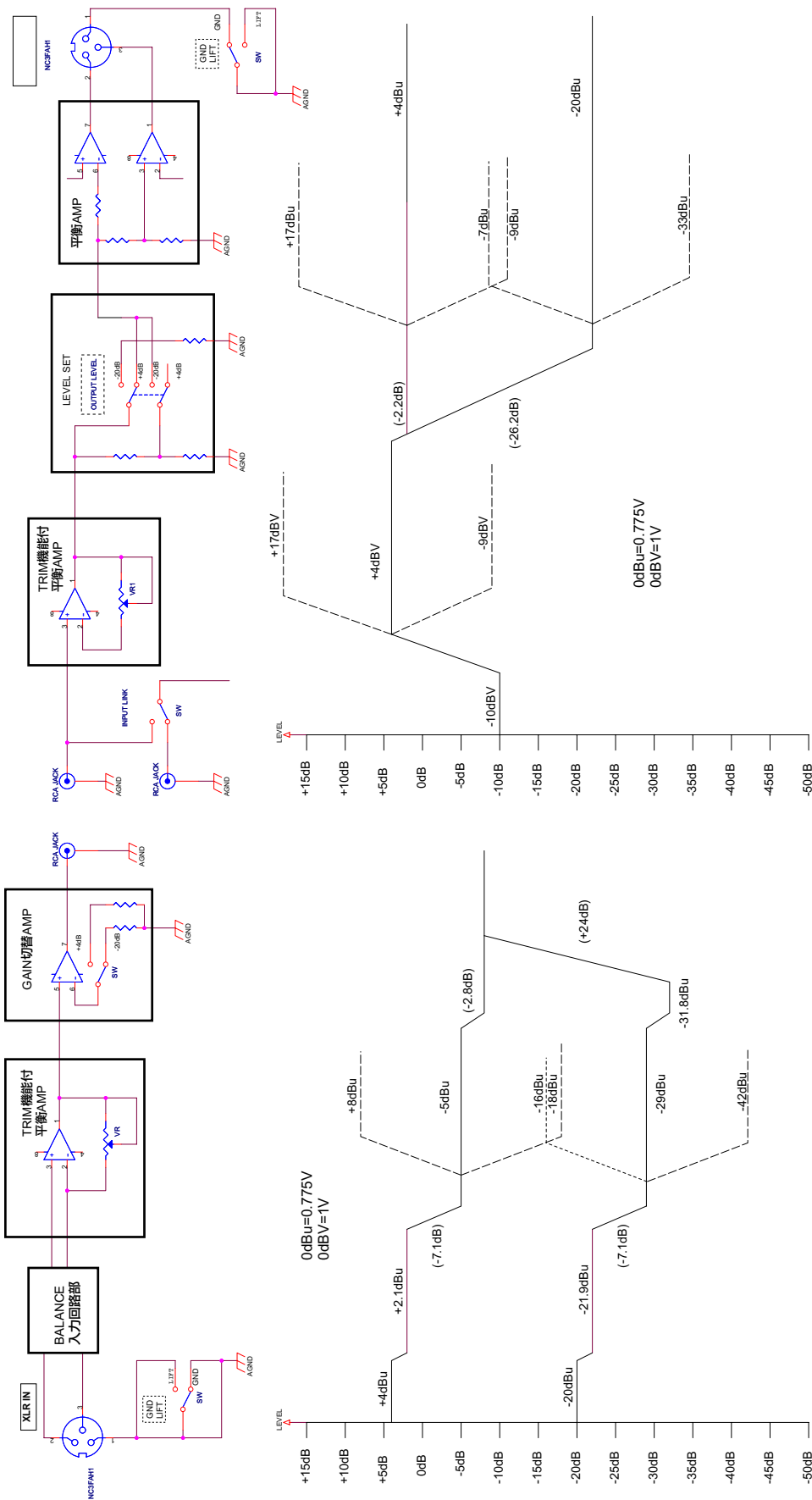

6. Exploded Views and Parts List

分解図とパーツリスト

Exploded View-1 (LA-80MKII)

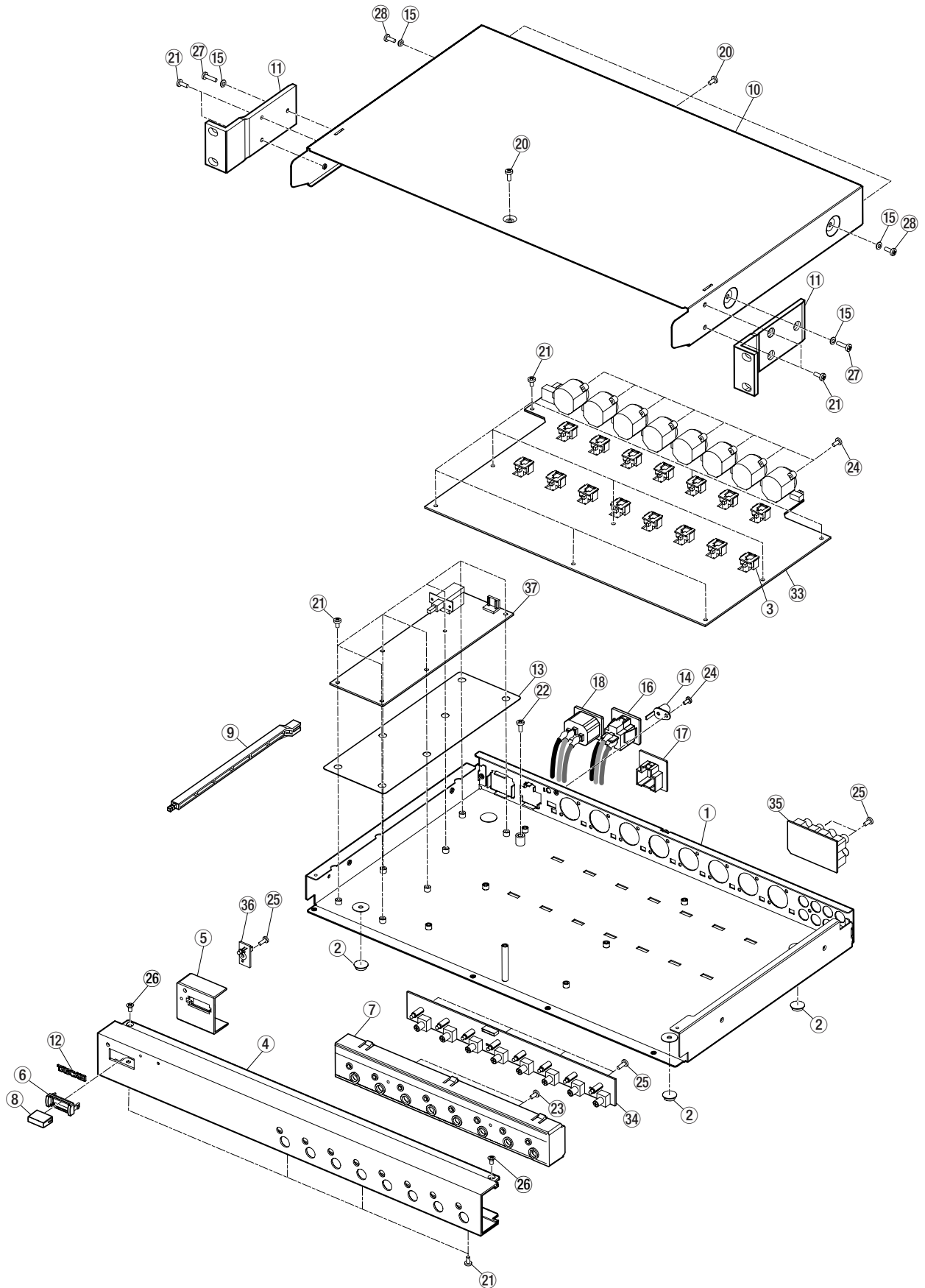

Exploded View-1

REF.NO.	PARTS NO.	DESCRIPTION	REMARKS
1- 1	M02856800B	CHASSIS,BOTTOM LA-80MK2 G	
1- 2	M01267300A	FOOT,D12.7H3.6 3M3J5012 G	
1- 3	M02857200B	KNOB,SLIDE LA-40MK3 G	
1- 4	M02856500A	FRONT PANEL,LA-80MK2 G	
1- 5	M02689900A	ESCUTCHEON,POWER 1641 G	
1- 6	M01890700B	ESCUTCHEON,POWER FLAT G	
1- 7	M02857000B	ESC,CONT LA-40MK3 G	
1- 8	M01891200C	BUTTON,POWER FLAT G	
1- 9	M02675800A	LINK,PWRSW 1641 G	
1-10	M02675500B	BONNET,1641 G	
1-11	M02137100A	ANGLE,RACK MOUNT 1U G	
1-12	3M0134900A	BADGE TASCAM SILVER G	
1-13	M02857100B	SHEET,POWER LA-40MK3 G	
1-14	3E017240G	GND TERMINAL G	
1-15	M02788000A	T LK WSHR,3D G	
1-16	△ E01557000	CONN,AC OUTLET AC-G07FB G [Except E]	
1-17	M02884400A	COVER,OUTLET LA40M3 EUR G [E]	
1-18	△ E01509600B	HARN ASSY,AC INLET LA G [Except E]	
	△ E01509650B	HARN ASSY,AC INLET EUR G [E]	
1-20	B00171404A	SCREW,BPA 3*4 FZB G	
1-21	B00171406A	SCREW,BPA 3*6 FZB G	
1-22	B00171508A	SCREW,BPA 4*8FZB G	
1-23	B00199706A	SCREW,BPB 3*6 FZB G	
1-24	B00199708A	SCREW,BPB 3*8 FZB G	
1-25	B00192708A	SCREW,BPP 3*8 FZB G	
1-26	3B0704806A	SCREW,FPA M3*6 FNI G	
1-27	B00197612A	SCREW,PPSU 3*12 FZB G	
1-28	B00197606A	SCREW,PPSU 3*6 FZB G	
1-33		PCBA,MAIN LA-80MK32 G	GATHER PCBA, LA-80MK2 G(Refer to page 13)
1-34		PCBA,LED&VR LA-80MK2 G	GATHER PCBA, LA-80MK2 G(Refer to page 13)
1-35		PCBA,RCA LA-80MK2 G	GATHER PCBA, LA-80MK2 G(Refer to page 13)
1-36		PCBA,PWR LED LA-80MK2 G	GATHER PCBA, LA-80MK2 G(Refer to page 13)
1-37		PCB ASSY,POWER LA G	GATHER PCBA,POWER LA G(Refer to page 15)
	E01528900B	HARN ASSY,TERMINAL LA G	
	E01509300A	HARN ASSY,PWR 6P LA G	

Exploded View-2 (LA-81MKII)

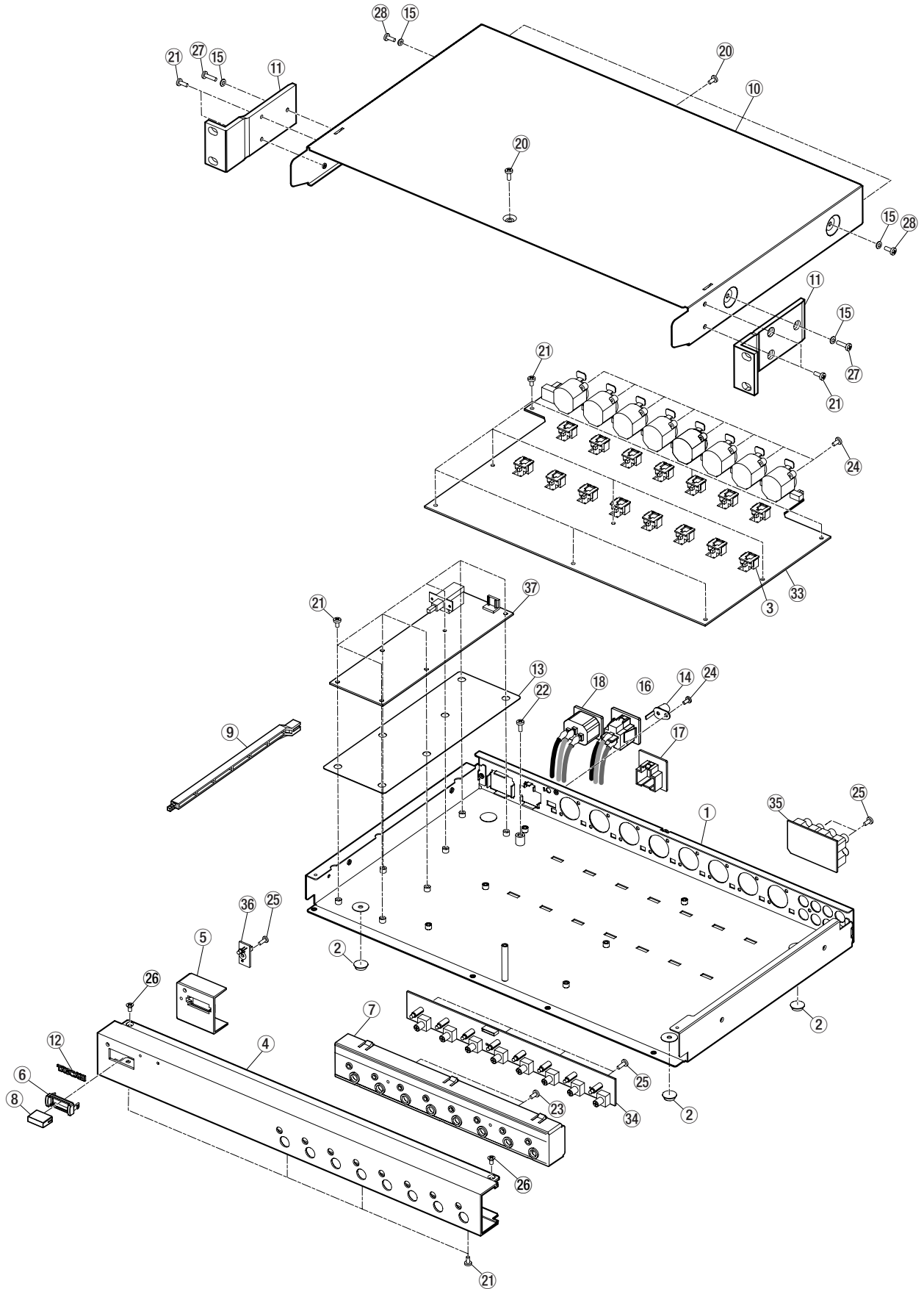

Exploded View-2

REF.NO.	PARTS NO.	DESCRIPTION	REMARKS
1- 1	M02856900B	CHASSIS,BOTTOM LA-81MK2 G	
1- 2	M01267300A	FOOT,D12.7H3.6 3M3J5012 G	
1- 3	M02857200B	KNOB,SLIDE LA-40MK3 G	
1- 4	M02856600A	FRONT PANEL,LA-81MK2 G	
1- 5	M02689900A	ESCUTCHEON,POWER 1641 G	
1- 6	M01890700B	ESCUTCHEON,POWER FLAT G	
1- 7	M02857000B	ESC,CONT LA-40MK3 G	
1- 8	M01891200C	BUTTON,POWER FLAT G	
1- 9	M02675800A	LINK,PWRSW 1641 G	
1-10	M02675500B	BONNET,1641 G	
1-11	M02137100A	ANGLE,RACK MOUNT 1U G	
1-12	3M0134900A	BADGE TASCAM SILVER G	
1-13	M02857100B	SHEET,POWER LA-40MK3 G	
1-14	3E017240G	GND TERMINAL G	
1-15	M02788000A	T LK WSHR,3D G	
1-16	△ E01557000	CONN,AC OUTLET AC-G07FB G [Except E]	
1-17	M02884400A	COVER,OUTLET LA40M3 EUR G [E]	
1-18	△ E01509600B	HARN ASSY,AC INLET LA G [Except E]	
	△ E01509650B	HARN ASSY,AC INLET EUR G [E]	
1-20	B00171404A	SCREW,BPA 3*4 FZB G	
1-21	B00171406A	SCREW,BPA 3*6 FZB G	
1-22	B00171508A	SCREW,BPA 4*8FZB G	
1-23	B00199706A	SCREW,BPB 3*6 FZB G	
1-24	B00199708A	SCREW,BPB 3*8 FZB G	
1-25	B00192708A	SCREW,BPP 3*8 FZB G	
1-26	3B0704806A	SCREW,FPA M3*6 FNI G	
1-27	B00197612A	SCREW,PPSU 3*12 FZB G	
1-28	B00197606A	SCREW,PPSU 3*6 FZB G	
1-33		PCBA,MAIN LA-81MK2 G	GATHER PCBA, LA-81MK2 G(Refer to page 14)
1-34		PCBA,LED&VR LA-81MK2 G	GATHER PCBA, LA-81MK2 G(Refer to page 14)
1-35		PCBA,RCA LA-81MK2 G	GATHER PCBA, LA-81MK2 G(Refer to page 14)
1-36		PCBA,PWR LED LA-81MK2 G	GATHER PCBA, LA-81MK2 G(Refer to page 14)
1-37		PCB ASSY,POWER LA G.....	GATHER PCBA,POWER LA G(Refer to page 15)
	E01528900B	HARN ASSY,TERMINAL LA G	
	E01509300A	HARN ASSY,PWR 6P LA G	

7. PC Boards and Parts List

基板図とパーツリスト

GATHER PCBA, LA-80MK2 G

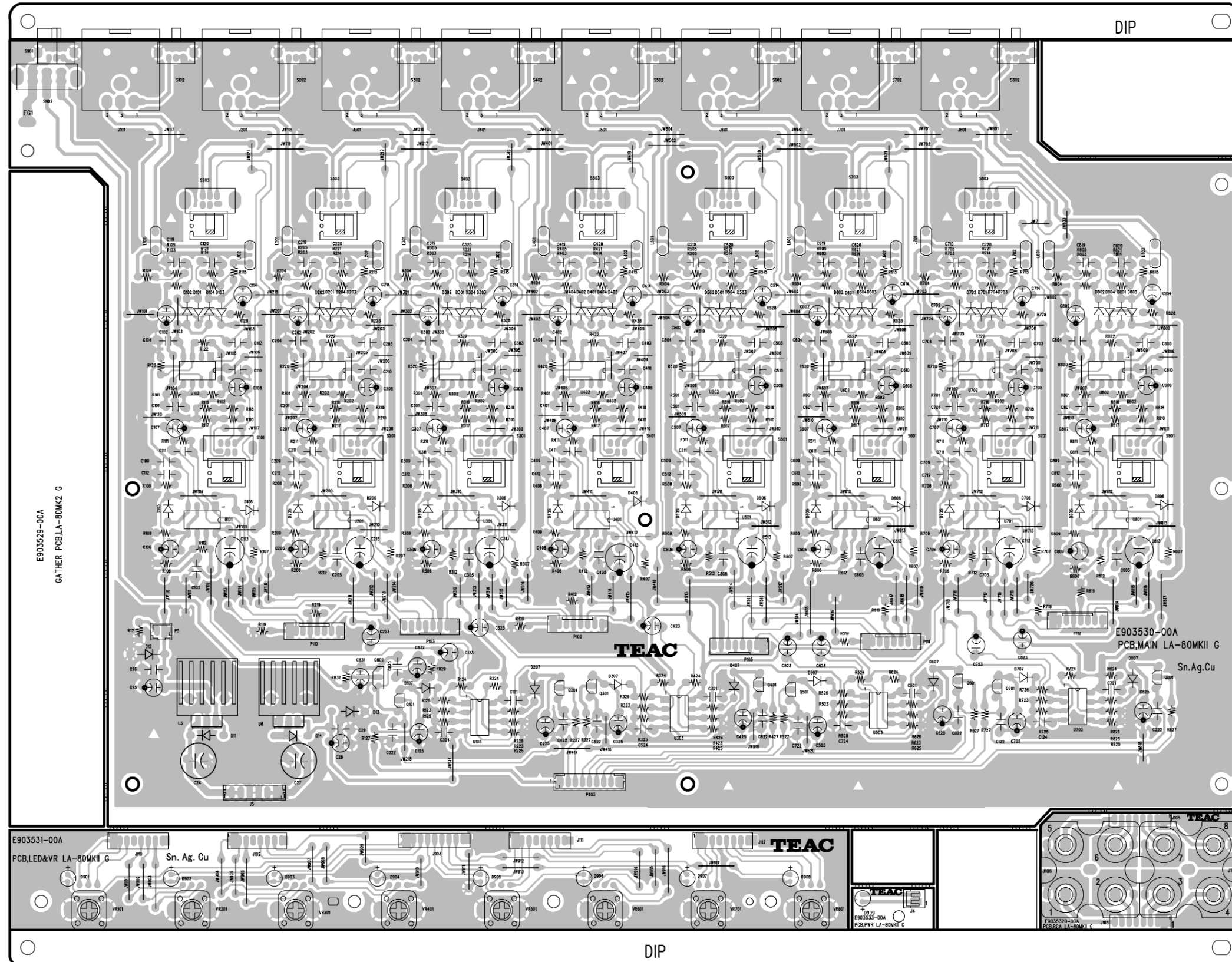

GATHER PCBA,POWER LA G (Common)

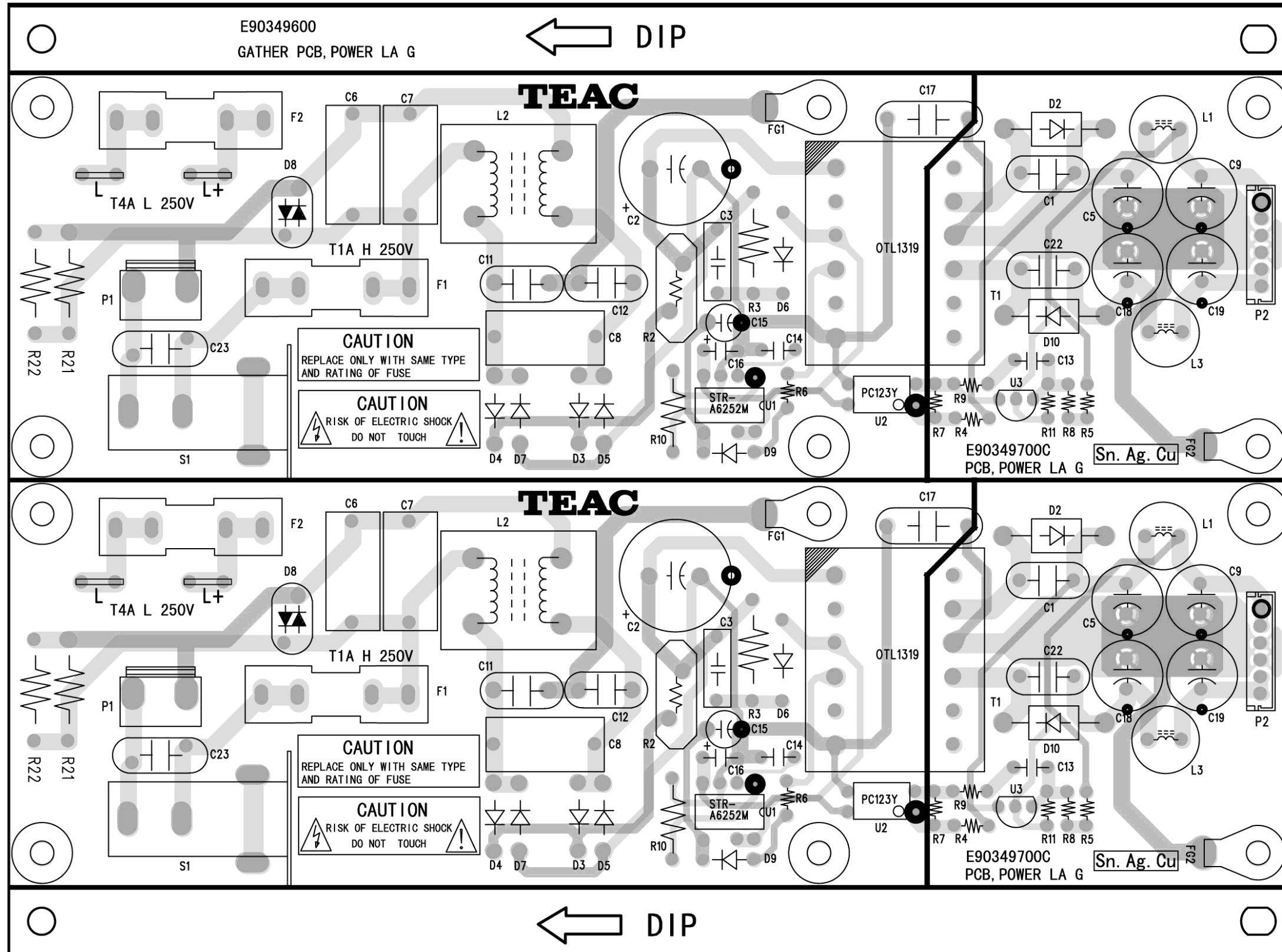

GATHER PCBA,LA-80MK2 G

REF.NO.	PARTS NO.	DESCRIPTION
	E95352900A	GATHER PCBA,LA-80MK2 G PCB,MAIN LA-80MK2 G PCB,LED&VR LA-80MK2 G PCB,RCA LA-80MK2 G PCB,PWR LED LA-80MK2 G
		PCBA,MAIN LA-80MK2 G
D11-D14	S0071811	DI,1N4003-F TAPINGW=52 G
D101-107	S0067021	DIODE,1SS133 T-77 G
D201-207	S0067021	DIODE,1SS133 T-77 G
D301-307	S0067021	DIODE,1SS133 T-77 G
D401-407	S0067021	DIODE,1SS133 T-77 G
D501-507	S0067021	DIODE,1SS133 T-77 G
D601-607	S0067021	DIODE,1SS133 T-77 G
D701-707	S0067021	DIODE,1SS133 T-77 G
D801-807	S0067021	DIODE,1SS133 T-77 G
FG1	E0123470	TERMINAL,GND-8 G
J5	E0126780	CONNECTOR,6P A2502WV W G
J101 J201	E0152690	JACK,NC3MAAH-0(XLR)G
J301 J401	E0152690	JACK,NC3MAAH-0(XLR)G
J501 J601	E0152690	JACK,NC3MAAH-0(XLR)G
J701 J801	E0152690	JACK,NC3MAAH-0(XLR)G
L101 L102	E0127040	BEAD COIL,FBR07HA850SB00G
L201 L202	E0127040	BEAD COIL,FBR07HA850SB00G
L301 L302	E0127040	BEAD COIL,FBR07HA850SB00G
L401 L402	E0127040	BEAD COIL,FBR07HA850SB00G
L501 L502	E0127040	BEAD COIL,FBR07HA850SB00G
L601 L602	E0127040	BEAD COIL,FBR07HA850SB00G
L701 L702	E0127040	BEAD COIL,FBR07HA850SB00G
L801 L802	E0127040	BEAD COIL,FBR07HA850SB00G
P5	E0126730	CONNECTOR,2P A2001WV W G
P102	E0152790	CONN,8P A2001WV RED G
P103	E0152860	CONN,8P A2001WV YEL G
P105	E0152810	CONN,8P A2001WV BLK G
P110	E0152210	CONNECTOR,8P A2001WV W G
P111	E0152210	CONNECTOR,8P A2001WV W G
P112	E0152790	CONN,8P A2001WV RED G
P903	E0152220	CONNECTOR,9P A2001WV W G
Q101 Q201	S0069232	TRANSISTOR,DTA124ESATP G
Q301 Q401	S0069232	TRANSISTOR,DTA124ESATP G
Q501 Q601	S0069232	TRANSISTOR,DTA124ESATP G
Q701 Q801	S0069232	TRANSISTOR,DTA124ESATP G
Q802	S0079392	TRANSISTOR,2SC1741AS TP G
S101 S201	E0128230	SW,SLIDE AXA 2-2-G
S102 S202	E0151000	SW SLIDE,SSAA110100 G
S203 S301	E0128230	SW,SLIDE AXA 2-2-G
S302 S402	E0151000	SW SLIDE,SSAA110100 G
S303 S401	E0128230	SW,SLIDE AXA 2-2-G
S403 S501	E0128230	SW,SLIDE AXA 2-2-G
S502 S602	E0151000	SW SLIDE,SSAA110100 G
S503 S601	E0128230	SW,SLIDE AXA 2-2-G
S603 S701	E0128230	SW,SLIDE AXA 2-2-G
S702 S802	E0151000	SW SLIDE,SSAA110100 G
S703 S801	E0128230	SW,SLIDE AXA 2-2-G

GATHER PCBA,LA-80MK2 G

REF.NO.	PARTS NO.	DESCRIPTION
S803	E0128230	SW,SLIDE AXA 2-2-G
S901	E0151000	SW SLIDE,SSAA110100 G
S902	E0152150	SW,SLIDE SK-22F10(2P2T) G
U5	S0079400	IC,NJM7815FA G
U6	S0079550	IC,NJM7915FA-#ZZZB G
U5 U6	3M0114700A	HEAT SINK 16.5X16X25 G
U5 U6	B00174006A	SCREW,BPA 3*6 FZC G
U101 U102	S0067650	IC,NJM4580D G
U103 U303	S0064550	IC,NJM4558D G
U201 U202	S0067650	IC,NJM4580D G
U301 U302	S0067650	IC,NJM4580D G
U401 U402	S0067650	IC,NJM4580D G
U501 U502	S0067650	IC,NJM4580D G
U503 U703	S0064550	IC,NJM4558D G
U601 U602	S0067650	IC,NJM4580D G
U701 U702	S0067650	IC,NJM4580D G
U801 U802	S0067650	IC,NJM4580D G
	E00942700B	HARNES ASSY,AC-E MD-CD1 G
		PCBA,LED&VR LA-80MK2 G
D901-D908	S0021800	LED,SLR-342MG
D901-D908	M0252020	SPACER,LEDH-11 G
J903	E01515300A	HARN ASSY,LED 9P LA G
J110 J111	E01515400B	HARN ASSY,VR 8P WHT LA G
J112 J102	E01527200A	HARN ASSY,VR 8P RED LA G
VR101 VR201	R0193070	VAR RES,RK09K1130-RD103 G
VR301 VR401	R0193070	VAR RES,RK09K1130-RD103 G
VR501 VR601	R0193070	VAR RES,RK09K1130-RD103 G
VR701 VR801	R0193070	VAR RES,RK09K1130-RD103 G
		PCBA,RCA LA-80MK2 G
J103	E01509400A	HARN ASSY,RCA1 BK 8P LA G
J105	E01509500A	HARN ASSY,RCA2 YEL 8P LA G
J106 J107	E0151840	JACK,4P RCA-406AE BLK G
		PCBA,PWR LED LA-80MK2 G
D909	S0065830	LED,SLR-342VR G
D909	M0287450	SPACER,LEDH-7 G
J4	E01509200A	HARN ASSY,2P LED LAG

GATHER PCBA, LA-81MK2 G

REF.NO.	PARTS NO.	DESCRIPTION
	E95353400A	GATHER PCBA,LA-81MK2 G PCB,MAIN LA-81MK2 G PCB,LED&VR LA-81MK2 G PCB,RCA LA-81MK2 G PCB,PWR LED LA-81MK2 G
		PCBA,MAIN LA-81MK2 G
D11-D14	S0071811	DI,1N4003-F TAPINGW=52 G
D101-D103	S0067021	DIODE,1SS133 T-77 G
D201-D203	S0067021	DIODE,1SS133 T-77 G
D301-D303	S0067021	DIODE,1SS133 T-77 G
D401-D403	S0067021	DIODE,1SS133 T-77 G
D501-D503	S0067021	DIODE,1SS133 T-77 G
D601 D602	S0067021	DIODE,1SS133 T-77 G
D607 D807	S0067021	DIODE,1SS133 T-77 G
D701-D703	S0067021	DIODE,1SS133 T-77 G
D801 D802	S0067021	DIODE,1SS133 T-77 G
FG1	E0123470	TERMINAL,GND-8 G
J5	E0126780	CONNECTOR,6P A2502WV W G
J101 J201	E0152680	JACK,NC3FAAH (XLR)G
J301 J401	E0152680	JACK,NC3FAAH (XLR)G
J501 J601	E0152680	JACK,NC3FAAH (XLR)G
J701 J801	E0152680	JACK,NC3FAAH (XLR)G
L101 L102	E0127040	BEAD COIL,FBR07HA850SB00G
L201 L202	E0127040	BEAD COIL,FBR07HA850SB00G
L301 L302	E0127040	BEAD COIL,FBR07HA850SB00G
L401 L402	E0127040	BEAD COIL,FBR07HA850SB00G
L501 L502	E0127040	BEAD COIL,FBR07HA850SB00G
L601 L602	E0127040	BEAD COIL,FBR07HA850SB00G
L701 L702	E0127040	BEAD COIL,FBR07HA850SB00G
L801 L802	E0127040	BEAD COIL,FBR07HA850SB00G
P5	E0126730	CONNECTOR,2P A2001WV W G
P103	E0152860	CONN,8P A2001WV YEL G
P105	E0152810	CONN,8P A2001WV BLK G
P110	E0126740	CONNECTOR,12P A2001WV W G
P111	E0152800	CONN,12P A2001WV YELL G
P903	E0152220	CONNECTOR,9P A2001WV W G
Q101 Q201	S0069232	TRANSISTOR,DTA124ESATP G
Q301 Q401	S0069232	TRANSISTOR,DTA124ESATP G
Q501 Q601	S0069232	TRANSISTOR,DTA124ESATP G
Q701 Q801	S0069232	TRANSISTOR,DTA124ESATP G
Q802	S0079392	TRANSISTOR,2SC1741AS TP G
S101 S201	E0128230	SW,SLIDE AXA 2-2-G
S102 S202	E0151000	SW SLIDE,SSAA110100 G
S203 S303	E0128230	SW,SLIDE AXA 2-2-G
S301 S401	E0128230	SW,SLIDE AXA 2-2-G
S302 S402	E0151000	SW SLIDE,SSAA110100 G
S403 S503	E0128230	SW,SLIDE AXA 2-2-G
S501 S601	E0128230	SW,SLIDE AXA 2-2-G
S502 S602	E0151000	SW SLIDE,SSAA110100 G
S603 S703	E0128230	SW,SLIDE AXA 2-2-G
S701 S801	E0128230	SW,SLIDE AXA 2-2-G
S702 S802	E0151000	SW SLIDE,SSAA110100 G

GATHER PCBA, LA-81MK2 G

REF.NO.	PARTS NO.	DESCRIPTION
S803	E0128230	SW,SLIDE AXA 2-2-G
S901	E0152150	SW,SLIDE SK-22F10(2P2T) G
S902	E0151000	SW SLIDE,SSAA110100 G
U5	S0079400	IC,NJM7815FA G
U6	S0079550	IC,NJM7915FA-#ZZZB G
U5 U6	3M0114700A	HEAT SINK 16.5X16X25 G
U5 U6	B00174006A	SCREW,BPA 3*6 FZC G
U101 U201	S0067650	IC,NJM4580D G
U102 U202	S0064550	IC,NJM4558D G
U301 U401	S0067650	IC,NJM4580D G
U302 U402	S0064550	IC,NJM4558D G
U501 U601	S0067650	IC,NJM4580D G
U502 U602	S0064550	IC,NJM4558D G
U701 U801	S0067650	IC,NJM4580D G
U702 U802	S0064550	IC,NJM4558D G
	E01555800A	WIRE,SINGLE WHT 95MM G
		PCBA,LED&VR LA-81MK2 G
D901-908	S0021800	LED,SLR-342MG
D901-908	M0252020	SPACER,LEDH-11 G
J110	E01515500A	HARN ASSY,VR 12P LA G
J111	E01527800A	HARN ASSY,VR 12P YEL LA G
J903	E01515300A	HARN ASSY,LED 9P LA G
VR101 VR201	R0193070	VAR RES,RK09K1130-RD103 G
VR301 VR401	R0193070	VAR RES,RK09K1130-RD103 G
VR501 VR601	R0193070	VAR RES,RK09K1130-RD103 G
VR701 VR801	R0193070	VAR RES,RK09K1130-RD103 G
		PCBA,RCA LA-81MK2 G
J103	E01509500A	HARN ASSY,RCA2 YEL 8P LA G
J105	E01509400A	HARN ASSY,RCA1 BK 8P LA G
J106 J107	E0151840	JACK,4P RCA-406AE BLKG
		PCBA,PWR LED LA-81MK2 G
D909	S0065830	LED,SLR-342VR G
D909	M0287450	SPACER,LEDH-7 G
J4	E01509200A	HARN ASSY,2P LED LAG

GATHER PCBA,POWER LA G (Common)

REF.NO.	PARTS NO.	DESCRIPTION
	E95349600A	GATHER PCBA,POWER LA G PCB,POWER LA G
		PCB ASSY,POWER LA G
C1 C22	C0032860	CC, 250V 2200PF M
C2	C0070752	CE,400V 47 UF M KM G
C3	C0042162	CQ,630V 0.01UF K
C6 C8	△ C0076090	CQ,0.1UFAC 275V-G
C7	△ C0059860	CQ,0.22UFAC 250VG
C11-C12	△ C0032860	CC, 250V 2200PF M
C17	△ C0040510	CC,E 250V 2200PF M KX G
C17	M02737300A	COVER,C 851440-23 G
C18-C19	C0066510	CE,LXV25VB470ME1 G
C23	△ E0127151	SPK KILLER,0.0047M250V G
C23	M02737300A	COVER,C 851440-23 G
D2 D10	S0066810	DIODE,MUR420G G
D3 D4	△ S0073370	DIODE,EM01A G
D5 D7	△ S0073370	DIODE,EM01A G
D6	S0069140	DIODE,FR 0.7A1000V RG-1CG
D8	△ R0175270	VARIATOR,DC470V ERZ G
D9	S0073460	DIODE,UFAST 200V AL01Z G
F1	△ E0143720	FUSE,1A 250V 215 001P G
F1 F2	E0126350	HOLDER,FUSE HOLDER 5.0 G
F2	△ 3E033020	FUSE,4A 250V T-G
FG1	E0123470	TERMINAL,GND-8 G
L L+	E0152160	PCB TERMINAL PC187 G
L1 L3	E0130740	COIL,10UH 3.6A DR2W8*7 G
L2	△ E0127050	COIL,2.2MH 1.3A LF2020G
P1	△ E0112450	CONNECTOR,B2P3VH(LF)(SN) G
P2	E0126780	CONNECTOR,6P A2502WV W G
R10	R0185461	RN,METAL1/2W 1 OHM J G
R2	△ R0176820	POWER THERMISTOR,16D-13 G
R21 R22	R0168791	RD,1/2W 2.2MOHM J TP G
R3	R0185651	RN,METEL1W330K OHM F TP G
S1	△ E0125690	SW,SFDLB11M7U G
T1	△ E0151020	TRANS,OTL3719 LA G
U1	S0073390	IC,STR-A6252M G
U2	S0067070	PHOTO COUPLER,PC123X2YFXG
U3	S0073400	IC,TL431CLPR G

REF.NO.	PARTS NO.	DESCRIPTION
---------	-----------	-------------

4. Included Accessories

付属品

Included Accessories (Common)

REF.NO.	PARTS NO.	DESCRIPTION	REMARKS
	△ E01469600A	POWER CORD,PSE TEAC 7A G [JEX,ETC]	
	△ 3E014160	POWER CORD,EUR-G [Except ETC]	
	△ 3E014150	POWER CORD,UL-G [ETC]	
	3M0028300A	ASSY,RACK MOUNT SCREW KIT SCREW,BPA M5X12 (NI) WASHER-FIBER(BLK)	
	D01047801A	OWNERS MNL,LA80/81MK2(J)G [JEX]	
	D01047820A	OWNERS MNL,LA80/81MK2(E)G [Except K]	
	D01047880A	OWNERS MNL,LA80/81MK2(G)G [E]	
	D01047881A	OWNERS MNL,LA80/81MK2(F)G [E]	
	D01047882A	OWNERS MNL,LA80/81MK2(I)G [E]	
	D01047883A	OWNERS MNL,LA80/81MK2(S)G [E]	

NOTES

- PC boards shown are viewed from parts side.
- Parts marked with * require longer delivery time.
- The parts with no reference number or no parts number in the exploded views are not supplied.
- As regards the resistors and capacitors, refer to the circuit diagrams contained in this manual.
- △ Parts marked with this sign are safety critical components. They must be replaced with identical components - refer to the appropriate parts list and ensure exact replacement.
- Parts of [] mark can be used only with the version designated.
[J] : JAPAN [US/C] : U.S.A./CANADA [K] : KOREA [E] : EUROPE
[UK] : U.K. [A] : AUSTRALIA [T] : TAIWAN [JEX] : JAPAN & ASIA
[CH] : CHINA [ETC] : U.S.A./CANADA/SOUTH AMERICA

注意

- プリント基板図は部品面を示しています。
- *印の部品は納期が若干かかります。
あらかじめご了承ください。
- 分解図に部番のない部品および品番のない部品は供給できません。
- 標準の抵抗、コンデンサーは省略してあります。
回路図を参照してください。
- △印は安全重要部品です。
交換する時は必ず指定の部品を使用してください。
- 仕向先
[J] : JAPAN [US/C] : U.S.A./CANADA [K] : KOREA
[E] : EUROPE [UK] : U.K. [A] : AUSTRALIA
[T] : TAIWAN [JEX] : JAPAN & ASIA [CH] : CHINA
[ETC] : U.S.A./CANADA/SOUTH AMERICA