

TASCAM
TEAC Professional Division

M-06

Audio Mixer
Mixeur Audio
Mischpult

SUPPLEMENT
SUPPLÉMENT
BEIHEFT

Fig. 1 MAIN MIX SYSTEM (AND MONITOR SYSTEM)

Fig. 1 SYSTEME DE MIXAGE PRINCIPAL (ET CELUI DE MONITOR)

Abb. 1 HAUPTMISCHSYSTEM (UND MONITORSYSTEM)

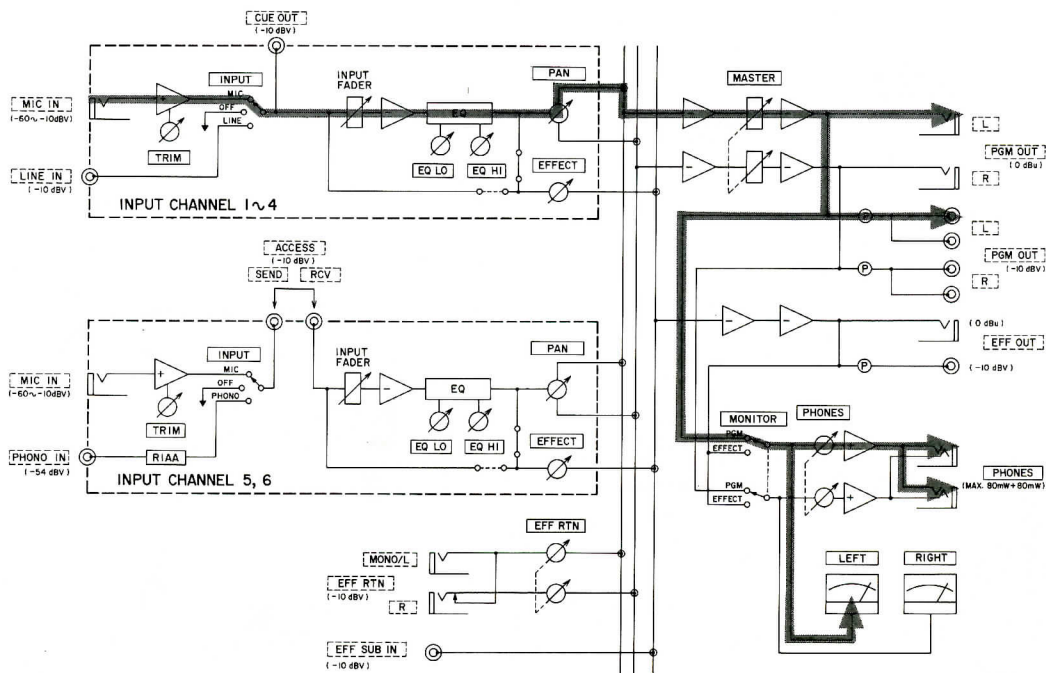
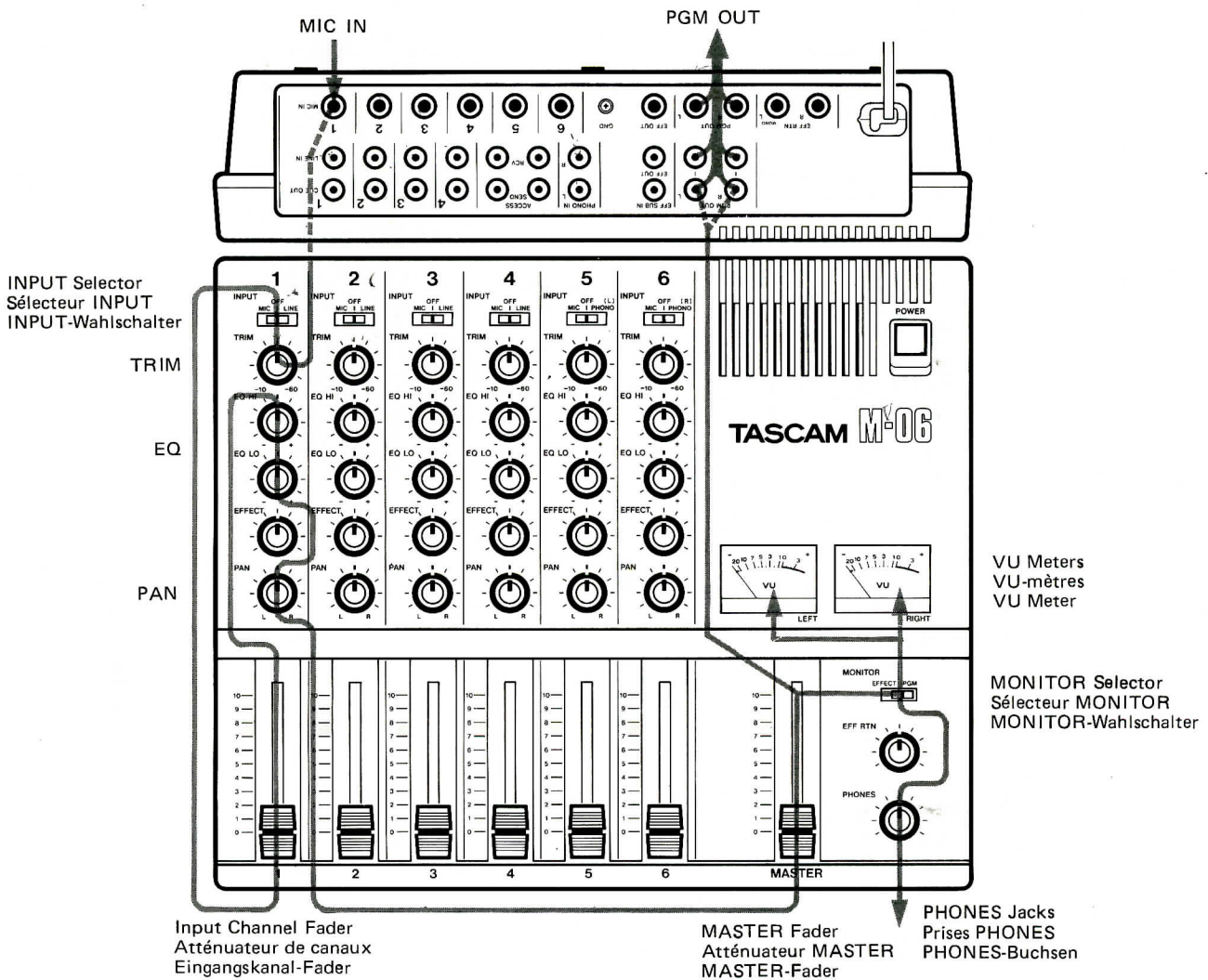

Fig. 2 EFFECT MIX SYSTEM (AND MONITOR SYSTEM)
 Fig. 2 SYSTEME DE MIXAGE EFFET (ET CELUI DE MONITOR)
 Abb. 2 EFFEKTMISCHSYSTEM (UND MONITORSYSTEM)

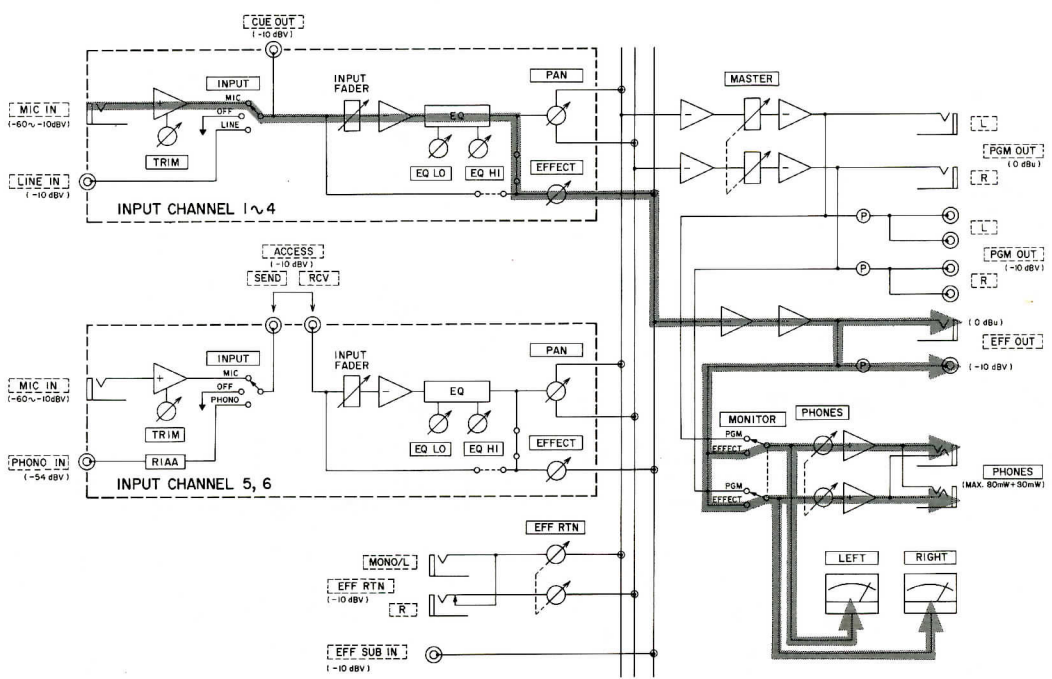
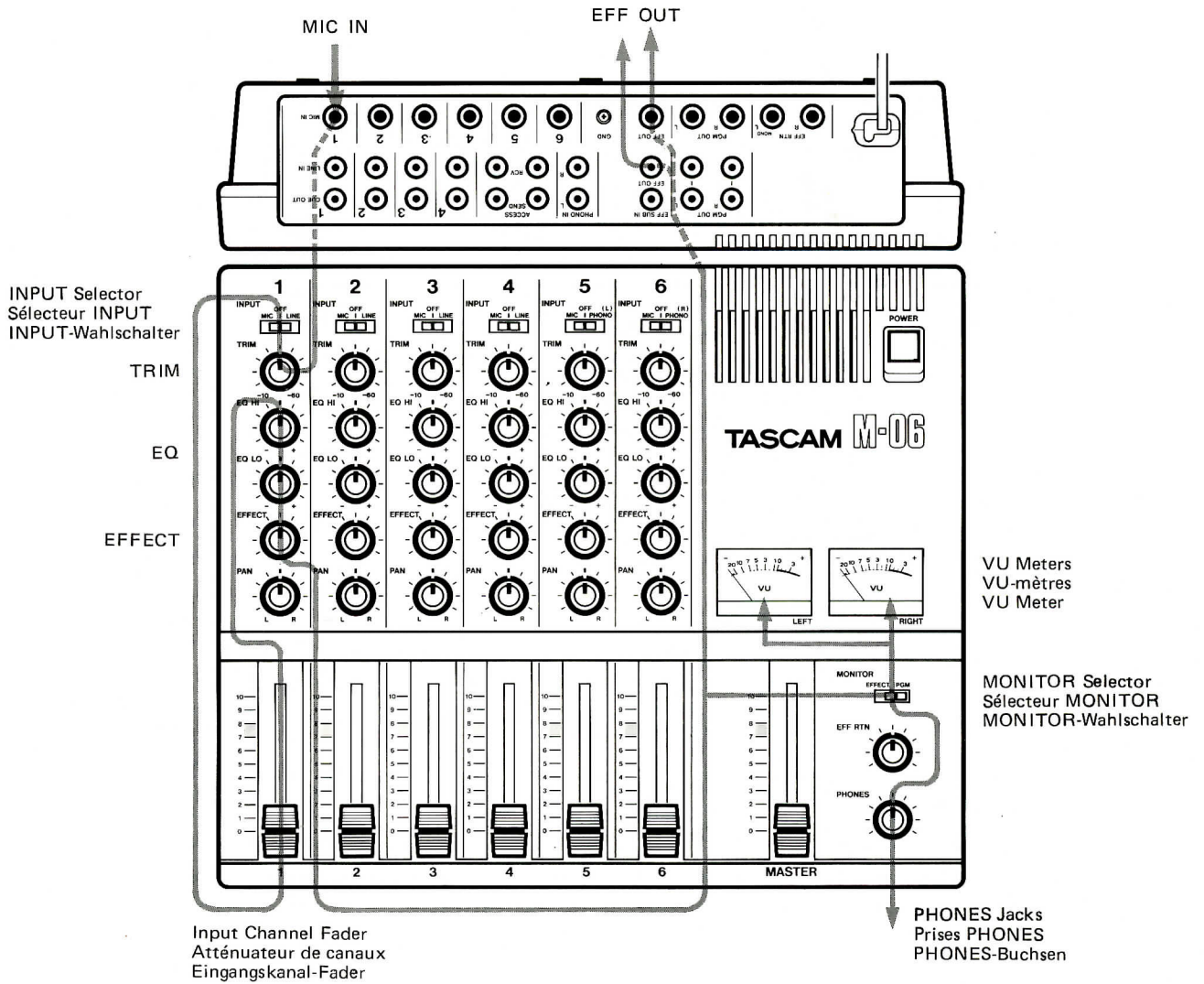

Fig. 3 "FEATURES AND CONTROLS"

Fig. 3 "DISPOSITIFS ET FONCTIONS"

Abb. 3 "MERKMALE UND BEDIENELEMENTE"

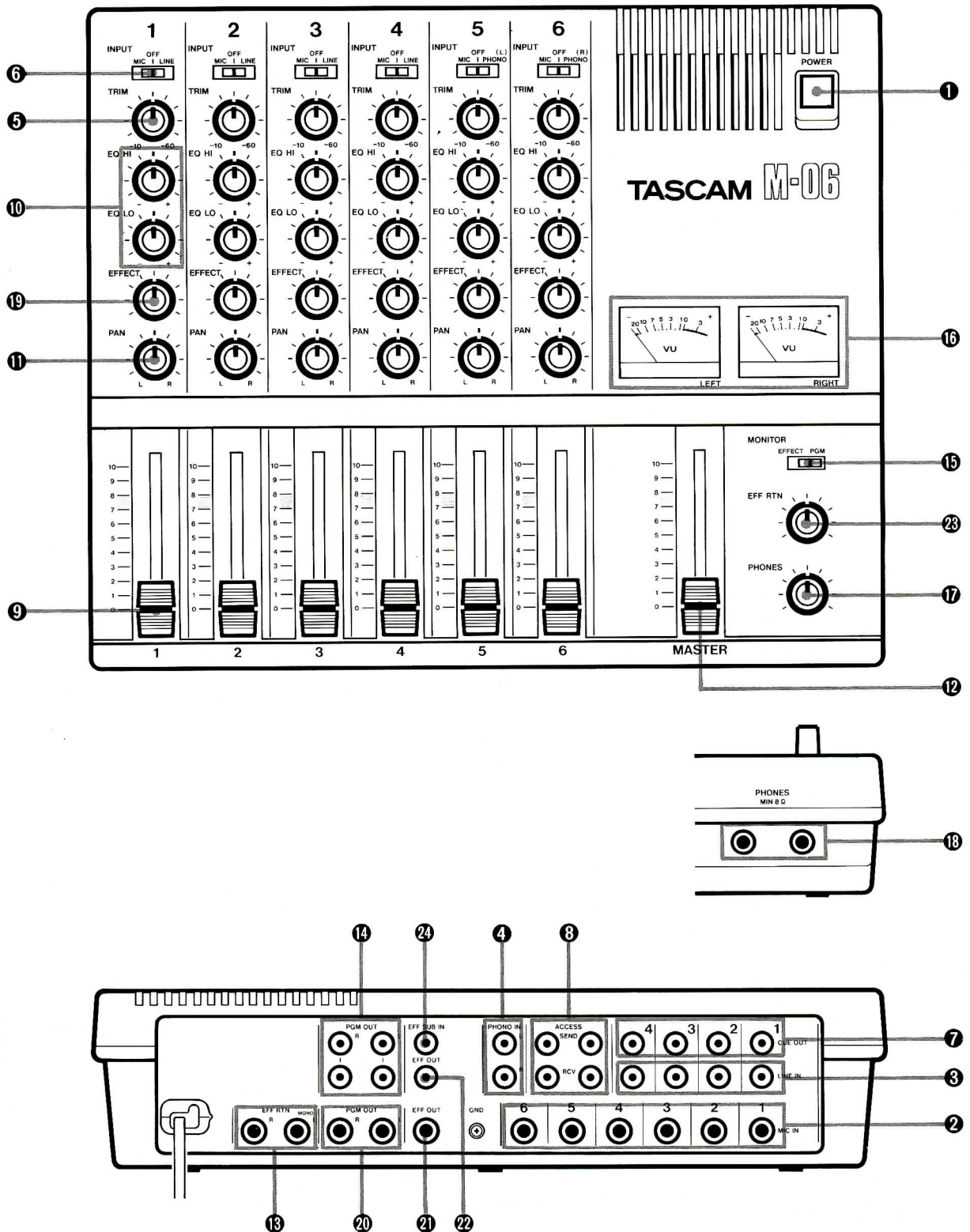

Fig. 4
Fig. 4
Abb. 4

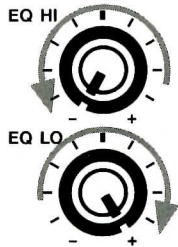
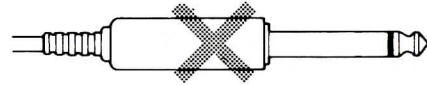
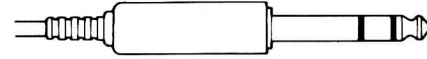

Fig. 5
Fig. 5
Abb. 5



(1/4" phone 2-conductor)
(Prise 6,35 à 2 conducteurs)
(1/4" - Klinkenstecker, 2 polig)



(1/4" phone 3-conductor)
(Prise 6,35 à 3 conducteurs)
(1/4" - Klinkenstecker, 3 polig)

Fig. 6
Fig. 6
Abb. 6

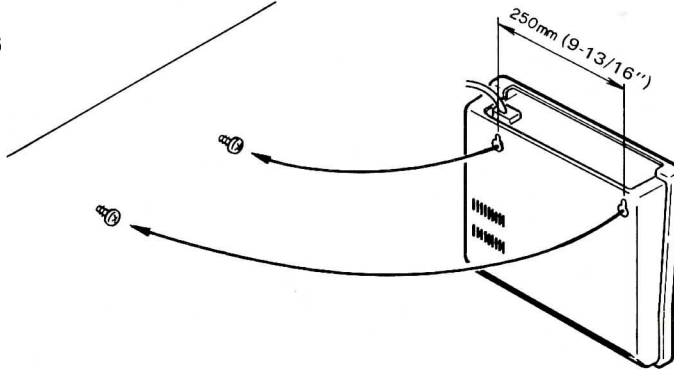

Fig. 7 BASIC PA
Fig. 7 SONORISATION
Abb. 7 LAUTSPRECHER/VERSTÄRKER-
BÜHNENANLAGE

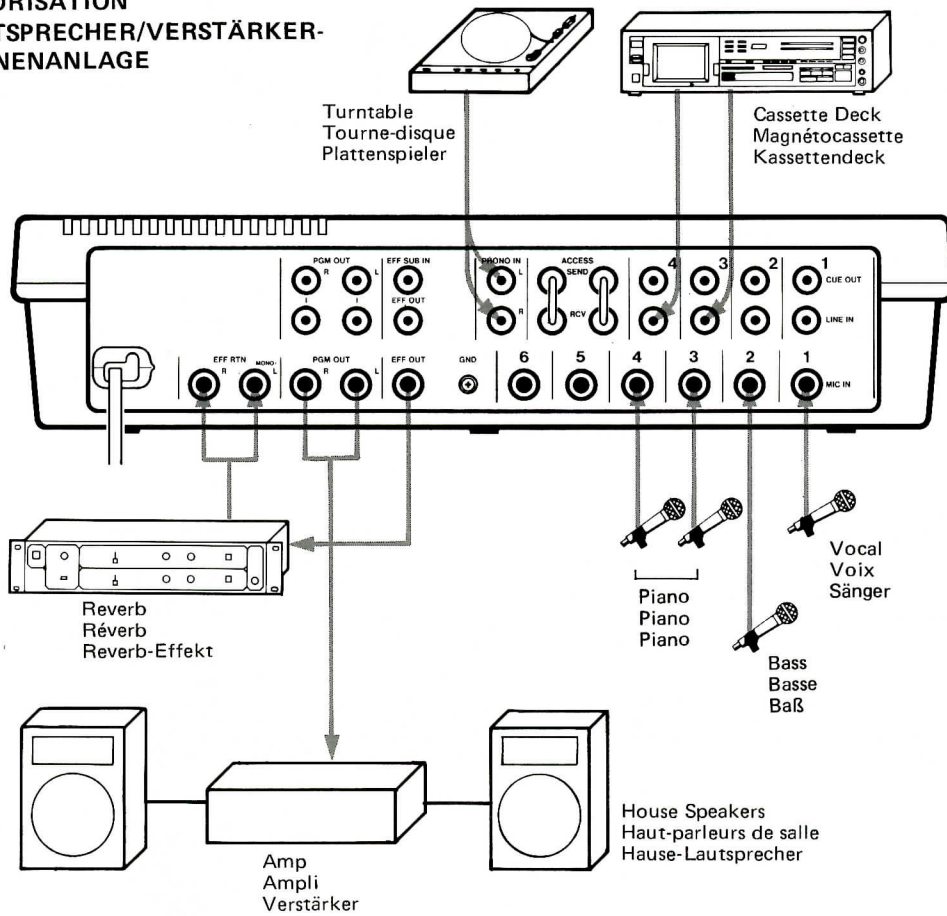

Fig. 8 DJ MIXING
 Fig. 8 MIXAGE DJ
 Abb. 8 DJ-MISCHSYSTEM

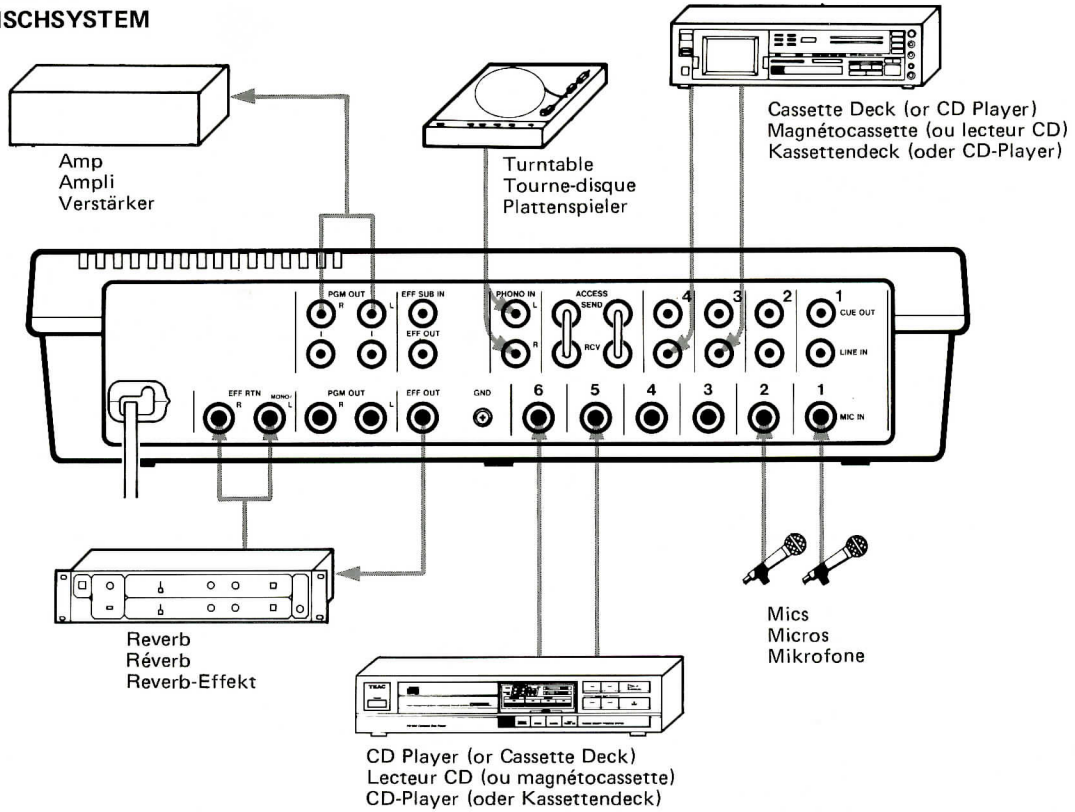

Fig. 9 USING AS A KEYBOARD SUB-MIXER AND SYSTEM EXPANSION
 Fig. 9 UTILISATION EN TANT QUE SOUS-MIXEUR POUR CLAVIERS ET EXPANSION DE SYSTEME
 Abb. 9 VERWENDUNG ALS KEYBOARD-SUBMIXER UND SYSTEMERWEITERUNG

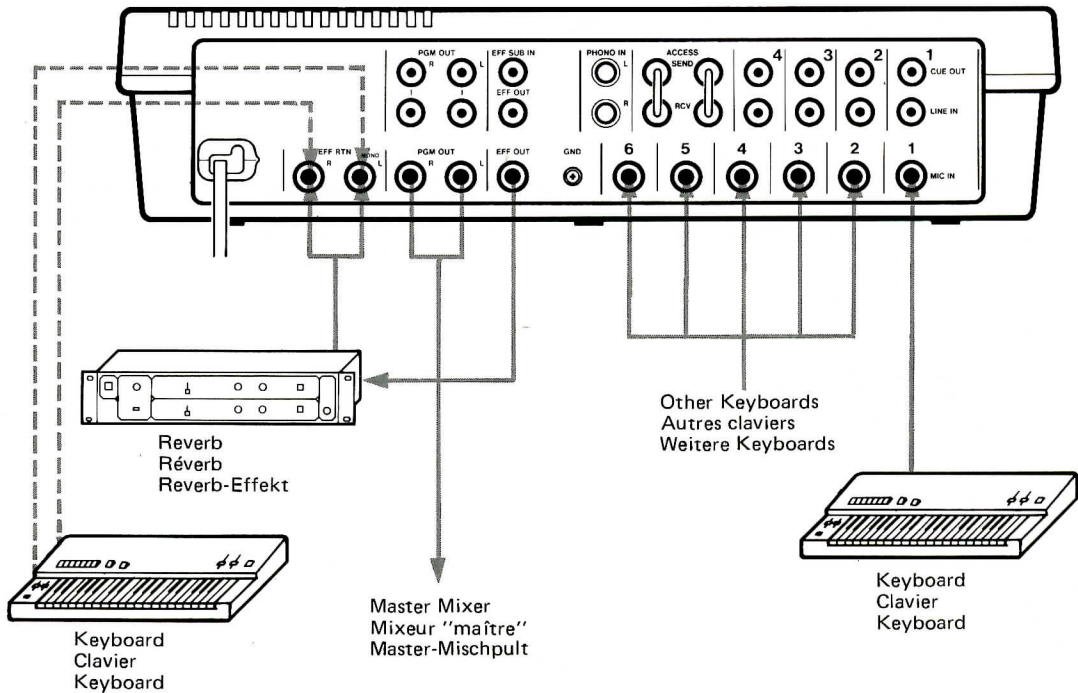

Fig. 10 RECORDING
 Fig. 10 ENREGISTREMENT
 Abb. 10 AUFNAHME

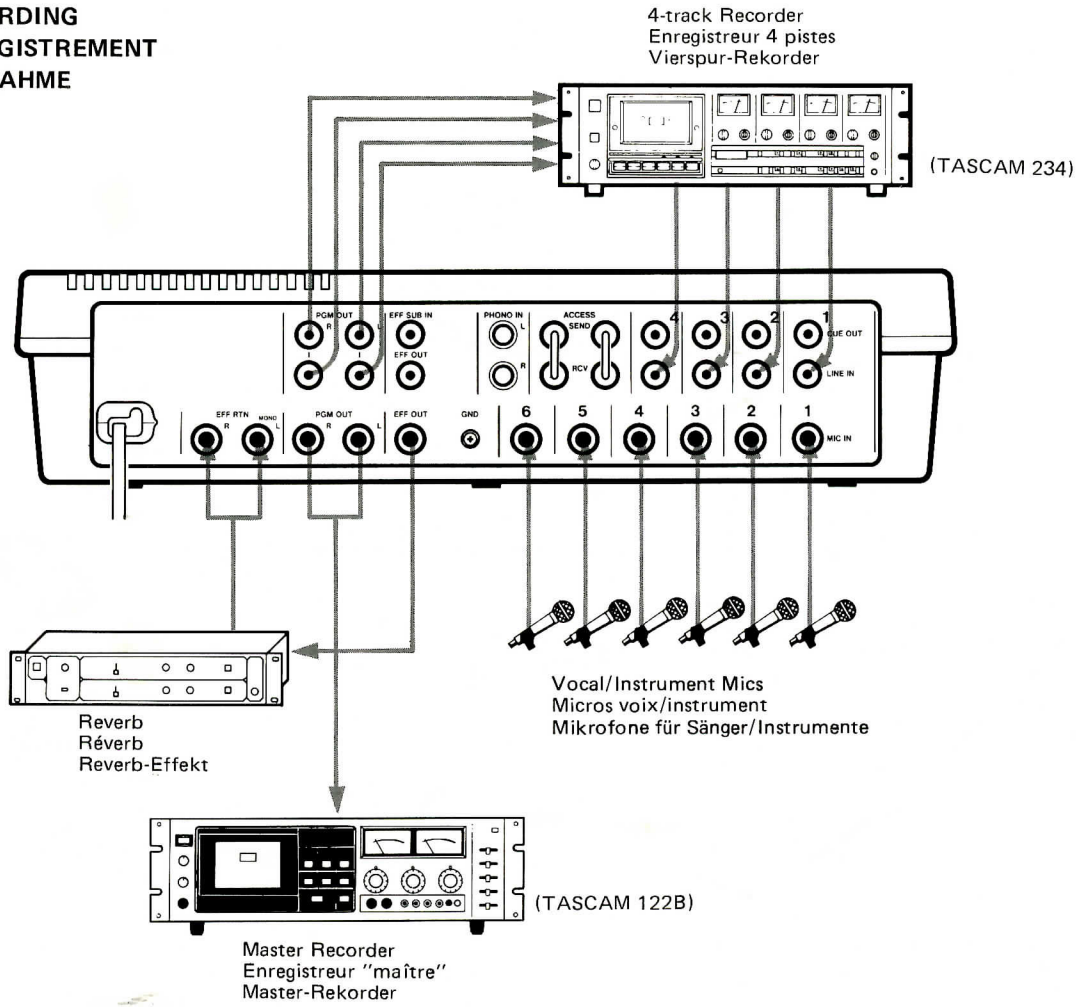

Fig. 11
 Fig. 11
 Abb. 11

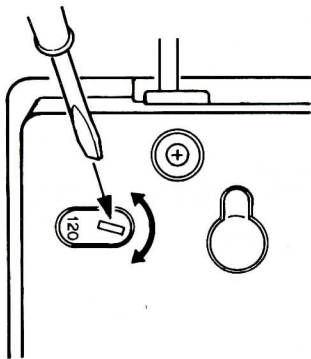

Fig. 12 EXTERNAL DIMENSIONS
 Fig. 12 DIMENSIONS EXTERIEURES
 Abb. 12 ABMESSUNGEN

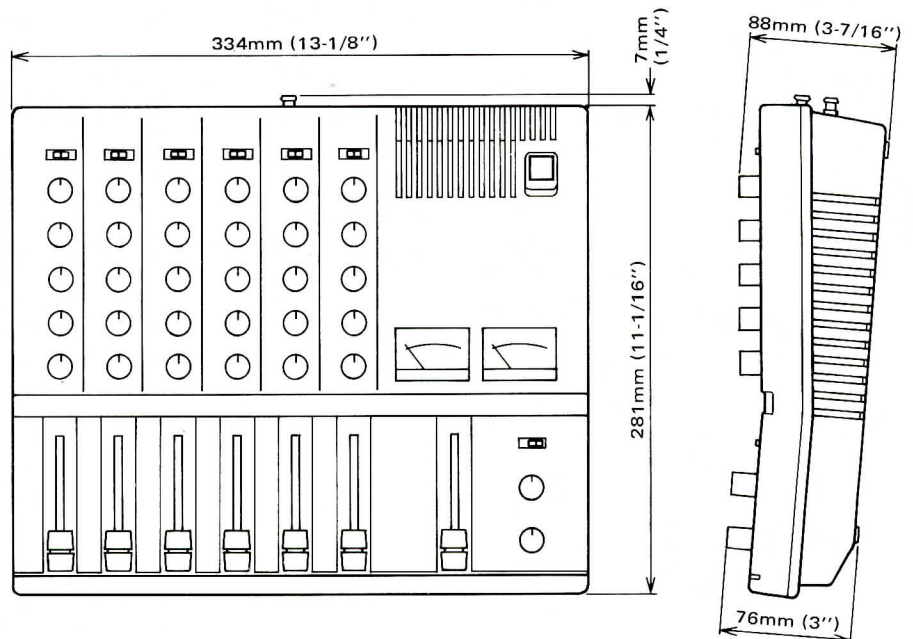
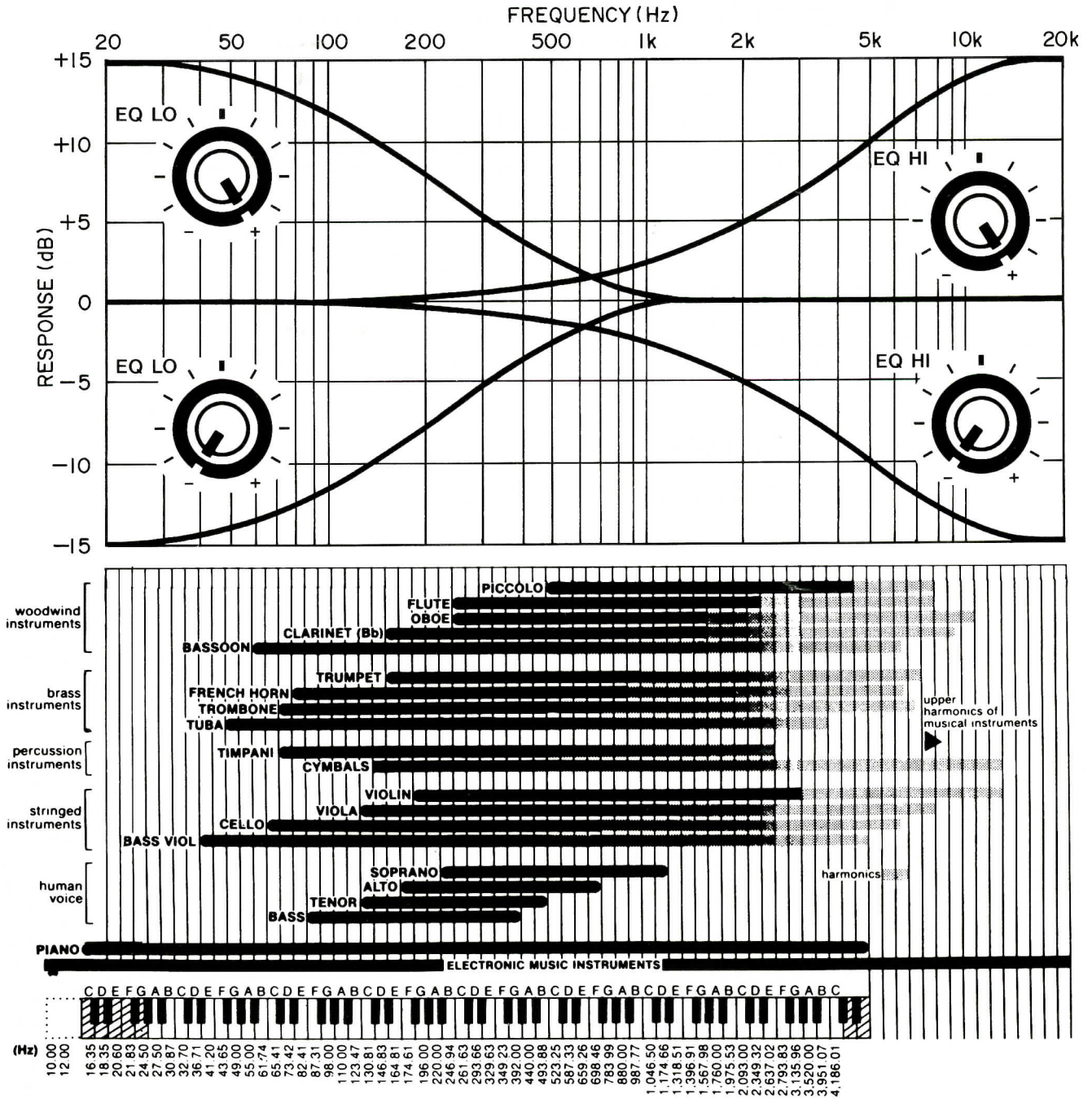
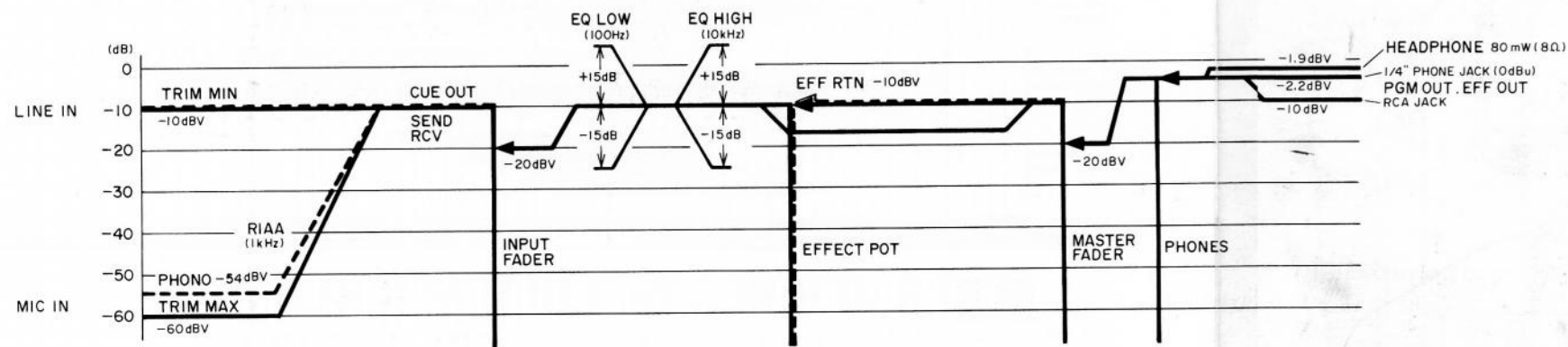
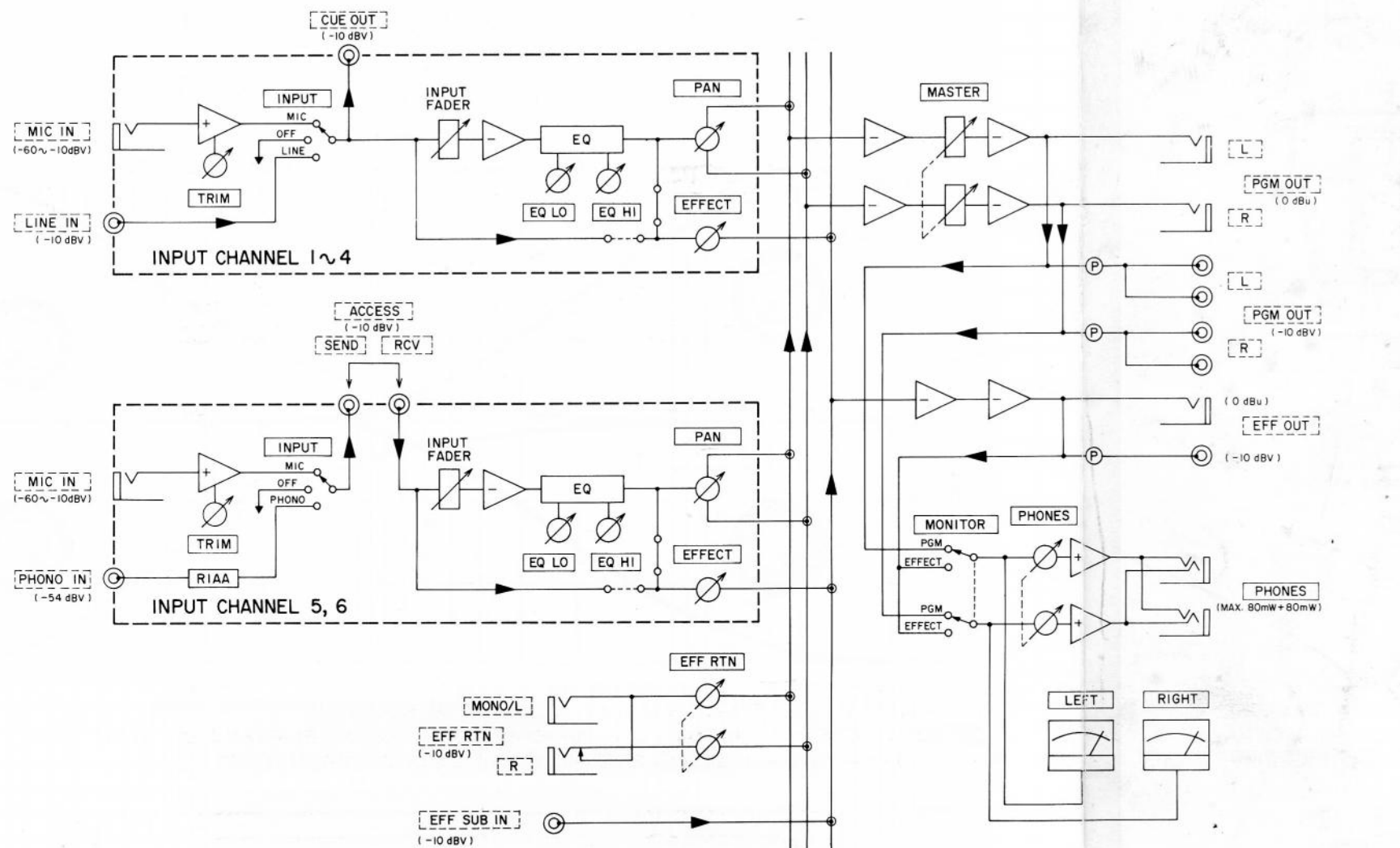

Fig. 13
 Fig. 13
 Abb. 13



**BLOCK DIAGRAM/LEVEL DIAGRAM
SCHEMA SYNOPTIQUE/DIAGRAMME DE NIVEAUX
BLOCK-DIAGRAMM/PEGEL-DIAGRAMM**



**USEFUL ACCESSORIES
ACCESSOIRES UTILES
ZUBEHÖR**

**PA-4 Phono Amplifier
Ampli phono PA-4
Phono-Verstärker PA-4**



**109B Input Transformer
Transfo de symétrisation/asymétrisation 109B
Mikrophoneingangs-Steckübertrager 109B**

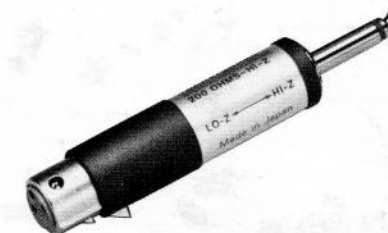

TEAC CORPORATION

MAIN OFFICE: 3-7-3 NAKACHO MUSASHINO TOKYO PHONE (0422) 53-1111
SALES OFFICE: 4-15-30 SHIMORENJAKU MITAKA TOKYO PHONE (0422) 45-7741

TEAC CORPORATION OF AMERICA 7733 TELEGRAPH ROAD MONTEBELLO CALIFORNIA 90640 PHONE (213) 726-0303
TEAC CANADA LTD. 3610 NASHUA DRIVE UNIT 1 & 2 MISSISSAUGA ONTARIO L4V 1L2 PHONE 416-673-3303
TEAC AUSTRALIA PTY., LTD. 115 WHITEMAN STREET SOUTH MELBOURNE VICTORIA 3205 PHONE 699-6000