

TASCAM

TEAC Professional Division

M-300 Series

Mixing Consoles

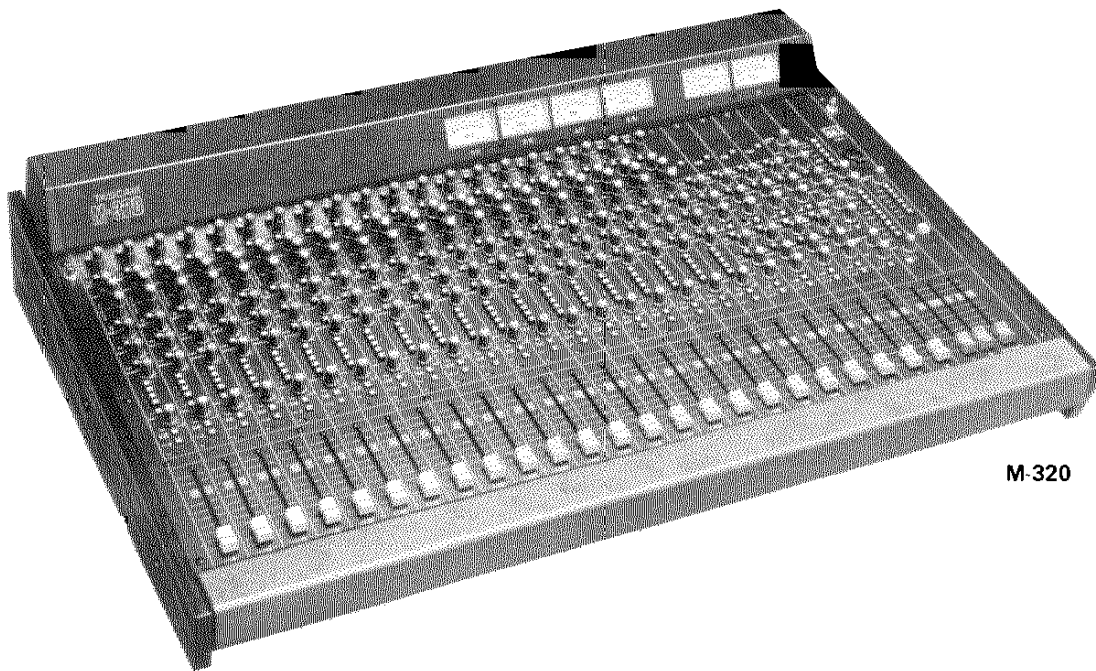

M-320

OPERATION/MAINTENANCE

5700064400



M-308



M-312



<p>CAUTION</p> <p>AVOID ELECTRICAL SHOCK BY NOT OPENING</p>	<p>CAUTION: TO REDUCE THE RISK OF ELECTRIC SHOCK, DO NOT REMOVE COVER (OR BACK). NO USER-SERVICEABLE PARTS INSIDE. REFER SERVICING TO QUALIFIED SERVICE PERSONNEL.</p>
	<p>The lightning flash with arrowhead symbol within an equilateral triangle, is intended to alert the user to the presence of uninsulated "dangerous voltage" within the product's enclosure, that may be of sufficient magnitude to constitute a risk of electric shock to persons.</p>
	<p>The exclamation point within an equilateral triangle is intended to alert the user of the presence of important operating and maintenance (servicing) instructions in the literature accompanying the appliance.</p>

TABLE OF CONTENTS

The guarantee of performance that we provide for the 300 Series Mixers must have several restrictions. We say that the 300 Series Mixers will perform properly only if they are adjusted properly and the guarantee is that such adjustment is possible. However, we cannot guarantee your skill in adjustment or your technical comprehension of this manual. Therefore, setup is not covered by the Warranty. If your attempts at internal adjustment are unsuccessful, we must make a service charge to correct your mistakes.

Recording is an art as well as a science. A successful recording is often judged primarily on the quality of sound as art, and we obviously cannot guarantee that. A company that makes paint and brushes for artists cannot say that the paintings made with their products will be well received critically. The art is the province of the artist. TASCAM can make no guarantee that the 300 Series Mixers *by themselves* will assure the quality of the recordings you make.

Your skill as a technician and your abilities as an artist will be significant factors in the results you achieve.

INTRODUCTION.....	9	Effects Return System	
Systems Introduction.....	11	39. EFFECT RTN.....	26
FEATURES AND FUNCTIONS		40. EFFECT RTN LEVEL Control.....	26
Input Channel Section		41. EFFECT RTN PAN Control.....	26
1. MIC INput Connector.....	14	42. EFFECT RTN PFL Switch.....	26
2. LINE INput.....	14	Stereo and Mono Master Sections	
3. TAPE or RETURN INput – Channels		43. Stereo Master Faders.....	26
1-8 Only.....	14	44. MONO Master Fader.....	26
4. LINE Switch.....	14	45. INSERTion Jack, Stereo and	
5. Pad Switch.....	14	MONO Masters.....	26
6. TRIM.....	14	46. STEREO and MONO OUTputS –	
7. EQualizer.....	15	XLR & RCA PHONO.....	26
8. EQ ON Switch.....	15	Monitor Section	
9, 10. AUXiliary 1 & 2 Controls.....	15	47. MONitor Select Switches.....	26
11, 12. AUXiliary LINE and POST Select		48. MONITOR Level Control.....	26
Switches.....	16	49. MONitor OUTPUTs.....	27
13. INSERTion Jack.....	17	50. PHONES Level Control.....	27
14. EFFECT Send Control.....	17	51. Headphone Output Jack.....	27
15. Channel Assign Switches.....	17	52. EXTERNAL INputs.....	27
16. PAN Control.....	17	53. SOLO Level Control and Indicator.....	27
17. Channel ON Switch.....	18	54. EXT SOLO.....	27
18. PFL (Pre Fader Listen) Switch.....	18	55. SOLO OUTPUT Jack.....	27
19. OL (OverLoad) Indicator.....	18	56. TALKBACK MIC Connector.....	28
20. Direct OUTput Jack.....	18	57. TALKBACK LEVEL Control.....	28
21. Channel Fader.....	18	58. TALKBACK SELECT Switches.....	28
Program Master Section		59. TALKBACK MASTER Switch.....	28
22. Program Master Fader.....	21	60. METER Select Switches.....	28
23. Program INSERTion Jack.....	21	61. Light Terminal.....	28
24. AFL (After Fader Listen) Switch.....	21	Additional Rear Panel Features	
Program (Group) Output Section – Rear		62. SUB IN Jacks.....	28
Panel Features		EXT SOLO and SENSE.....	28
25. PGM OUTput Connector – XLR.....	21	TAPE INs.....	28
26. PGM OUTputS – RCA.....	21	OPERATIONAL NOTES AND	
Meter Select and Tape Return Monitor		APPLICATIONS	
Section		BASIC SOUND REINFORCEMENT.....	31
27. VU Meters.....	22	Basic Connections.....	31
28. Peak LEDs.....	22	Adding More Input Signals.....	34
29. METER Select Switches.....	22	Setting Auxiliary and Effects Send	
30. TAPE RTN Select Switch.....	22	Levels.....	34
31. AUX 3, AUX 4 Send Controls		Setting the Final Output Level.....	35
(M-312 & M-320 Only).....	22	BASIC RECORDING PROCEDURE.....	36
32. AUX 3 & 4 POST Switch		Basic Connections.....	36
(M-312 & M-320 Only).....	22	Recording the Basic Tracks.....	38
33. Monitor LEVEL Control.....	22	Eight Track Recording.....	39
34. Monitor PAN Control.....	22	Mixdown Procedure.....	39
35. Monitor ON Switch and LED		VIDEO PRODUCTION, POST	
Indicator.....	22	PRODUCTION, AND AUDIO	
Auxiliary and Effects Master Send Controls		SWEETENING.....	40
36. MASTER Level Controls.....	25	CALIBRATING THE 300 SERIES	
37. AUX 3 & 4 SUM Switch		MIXERS FOR RECORDING.....	42
(M-312 & M-320 Only).....	25		
38. AUX and EFFECTS OUTPUTS.....	26		

This unit has a serial number located on the rear panel. Please record the model number and serial number and retain them for your records.
 Model Number.....
 Serial Number.....

WARNING: TO PREVENT FIRE OR SHOCK HAZARD, DO NOT EXPOSE THIS APPLIANCE TO RAIN OR MOISTURE.

HOW TO USE EQUALIZER (EQ)
SECTION ON THE 300 MIXER 44
 Pre & Post EQ When Using a Limiter 46

A WORD OF MIXING ADVICE 46

ACCESSORIES FOR THE 300 SERIES MIXERS

MC-701G Gooseneck Microphone 47
 PW-2Y/PW-4Y Insertion Cable 47
 MH-40B Headphone Amplifier 47
 TZ-23 Fader-Link Knobs 47
 The PB-64 Patch Bay 48
 TASCAM PB-32 Series Patch Bays 48
 TASCAM Cables 50

M-308 SPECIFICATIONS 51
M-312 SPECIFICATIONS 53
M-320 SPECIFICATIONS 55

VOLTAGE CONVERSION 60
NOTE FOR U.K. CUSTOMERS 61

M-308 BLOCK DIAGRAM 63
M-312/M-320 BLOCK DIAGRAM 65

M-308 LEVEL DIAGRAMS 67
M-312/M-320 LEVEL DIAGRAMS 71

MAINTENANCE

1. LEVEL SETTING AND OPERATION CHECK

1-1. MASTER FADERS AND POTS ... 1-1
 1-2. VU METERS 1-1
 1-3. PEAK LEDS 1-1
 1-4. CHANNEL FADERS AND POTS
 1) Channel Faders
 (INSERT → D. OUT) 1-4
 2) TRIM-LINE Pot
 (LINE IN → D. OUT) 1-4
 3) Equalizer (LINE IN → D. OUT) ... 1-4
 4) AUX 1 and AUX 2 Level POTs
 (LINE IN → AUX 1, AUX 2
 OUTPUTs) 1-4
 5) EFFECT Send Control
 (LINE IN → EFFECT OUTPUT) ... 1-4
 6) TRIM-MIC Pot
 (MIC IN → D. OUT) 1-4
 7) Mic Pad (30 dB) 1-5
 B) OL (OverLoad) Indicator
 (MIC IN → INSERT Send Contact) .. 1-6

9) Channel Assign Switches and Controls
 (MIC IN → PGM OUT 1-4, STEREO
 OUTPUT L & R) 1-6
 1-5. MON(ITOR) OUT L & R 1-7
 1-6. EFFECT RTN SYSTEM
 (EFFECT RTN → STEREO
 OUT L & R) .. 1-8
 L & R)
 1-7. PGM OUT/TAPE RTN MONITOR
 SYSTEMS
 1) PGM OUT Monitor System
 (PGM → STEREO OUT L & R) 1-9
 2) TAPE RTN Select Switch 1-9
 1-8. AUX 3, AUX 4 OUTPUTS
 (312 & 320 ONLY) 1-10
 1-9. TALKBACK SYSTEM
 (312 & 320 ONLY) 1-10
 1-10. FREQUENCY RESPONSE 1-11
 1-11. T.H.D. 1-11
 1-12. S/N RATIO 1-11

**EXPLODED VIEWS, ASSEMBLIES, PARTS
 LISTS AND CIRCUIT SCHEMATICS**

**2. MECHANICS – EXPLODED VIEWS AND
 PARTS LISTS**

2-1. Exploded View – 1
 (Dress Panel – M-308) 2-1
 2-2. Exploded View – 2
 (Dress Panel – M-312/M-320) 2-3
 2-3. Exploded View – 3 (Top Panel) ... 2-5
 2-4. Exploded View – 4 (Meter Section,
 Side Chassis R Section) 2-7
 2-5. Exploded View – 5 (Rear Panel) ... 2-9

**3. ELECTRONICS – PCB'S AND
 ELECTRONIC COMPONENTS**

3-1. INPUT PCB Ass'y 3-1, 3-2
 3-2. INPUT JACK PCB Ass'y ... 3-2, 3-3
 3-3. INPUT BUSS A PCB Ass'y 3-4
 3-4. INPUT BUSS B PCB Ass'y
 (M-312/M-320) 3-4
 3-5. INPUT BUSS C PCB Ass'y
 (M-320) 3-4
 3-6. BUSS AMP PCB Ass'y 3-6
 3-7. BUSS JACK PCB Ass'y 3-8
 3-8. BAL AMP L PCB Ass'y 3-8
 3-9. BAL AMP R PCB Ass'y 3-8
 3-10. AUX PCB Ass'y 3-10
 3-11. MONO AMP PCB Ass'y 3-12
 3-12. MONITOR PCB Ass'y 3-13, 3-14
 3-13. MON BUSS PCB Ass'y 3-16
 3-14. METER PCB Ass'y 3-16

3-15. TALKBACK PCB Ass'y
 (M-312/M-320) 3-18
 3-16. JACK A PCB Ass'y 3-20
 3-17. JACK B PCB Ass'y 3-20
 3-18. JACK C PCB Ass'y 3-20
 3-19. SUB IN PCB Ass'y 3-22
 3-20. TB MIC PCB Ass'y
 (M-312/M-320) 3-22
 3-21. TR PCB Ass'y (A) 3-23
 3-22. TR PCB Ass'y (B) 3-23
 3-23. POWER SUPPLY PCB Ass'y ... 3-24
 3-24. SW PCB Ass'y 3-24
 3-25. RIAA PCB Ass'y (M-308)
 (Japan Model Only) 3-27

4. SCHEMATIC DIAGRAMS

4-1. Wiring Diagram (M-308) 4-1
 4-2. Wiring Diagram (M-312) 4-2
 4-3. Wiring Diagram (M-320) 4-3
 4-4. Input PCB Ass'y 4-4
 4-5. Buss Amplifier PCB Ass'y (M-308) .. 4-5
 4-6. Buss Amplifier PCB Ass'y
 (M-312/M-320) 4-6
 4-7. Auxiliary PCB Ass'y (M-308) 4-7
 4-8. Auxiliary PCB Ass'y
 (M-312/M-320) 4-8
 4-9. Balanced Amplifier L PCB Ass'y ... 4-9
 4-10. Balanced Amplifier R PCB Ass'y .. 4-10
 4-11. Mono Amplifier PCB Ass'y
 (M-308) 4-11
 4-12. Mono Amplifier PCB Ass'y
 (M-312/M-320) 4-12
 4-13. Monitor PCB Ass'y (M-308) 4-13
 4-14. Monitor PCB Ass'y
 (M-312/M-320) 4-14
 4-15. Meter PCB Ass'y 4-15
 4-16. Talkback PCB Ass'y
 (M-312/M-320) 4-16
 4-17. Power Supply Section (M-308) ... 4-17
 4-18. Power Supply Section
 (M-312/M-320) 4-18
 4-19. RIAA PCB (M-308)
 (Japan Model Only) 4-19
 4-20. IC Internal Block Diagrams 4-20
 4-21. Block Diagram (M-308) 4-21
 4-22. Block Diagram (M-312/M-320) ... 4-22
 4-23. Level Diagrams (M-308) ... 4-23, 4-24
 4-24. Level Diagrams
 (M-312/M-320) 4-25, 4-26

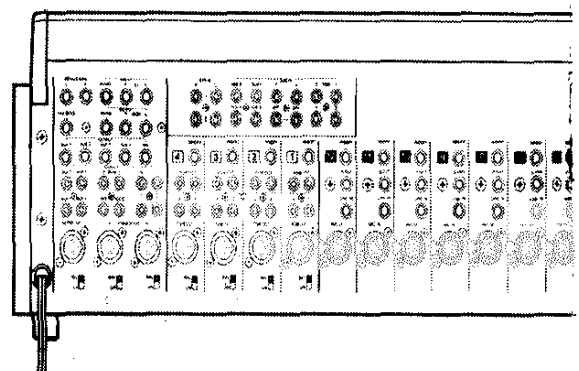
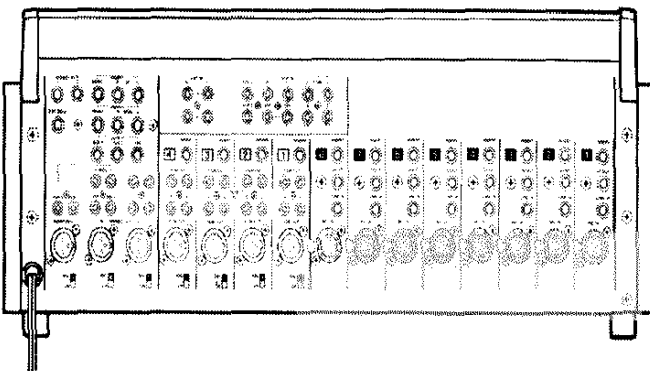
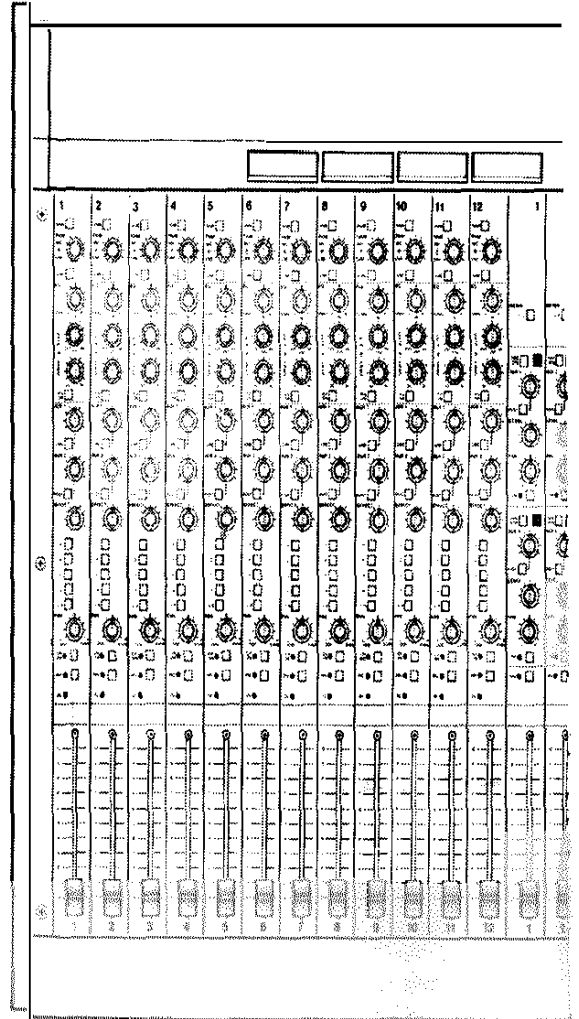
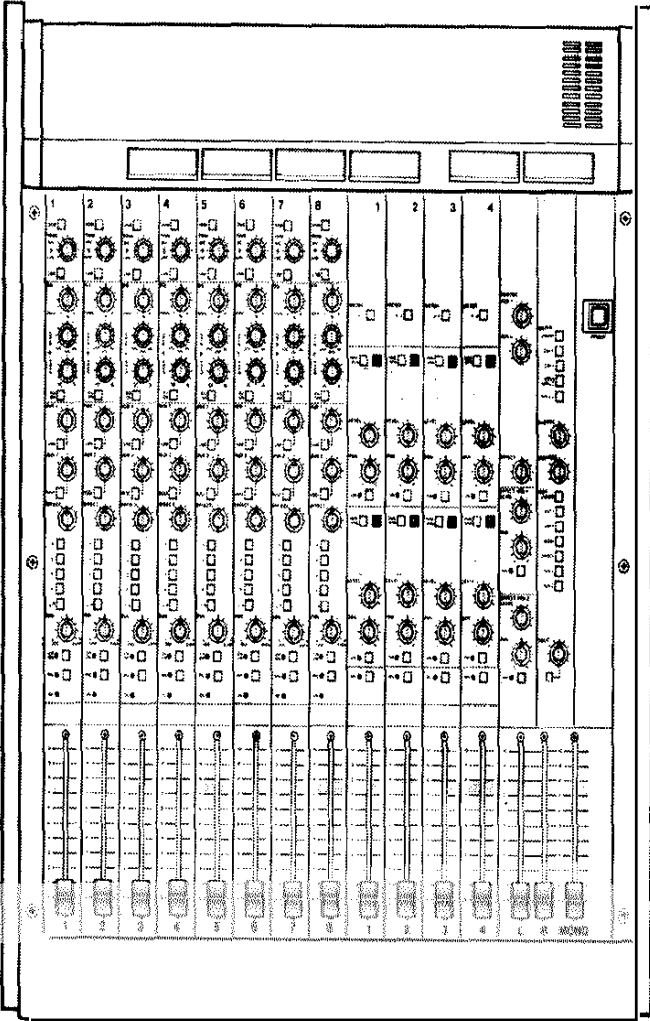
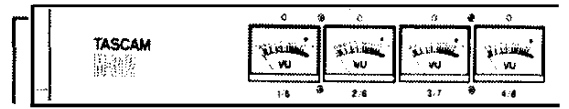
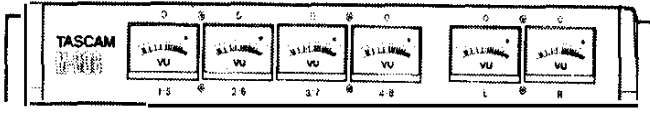

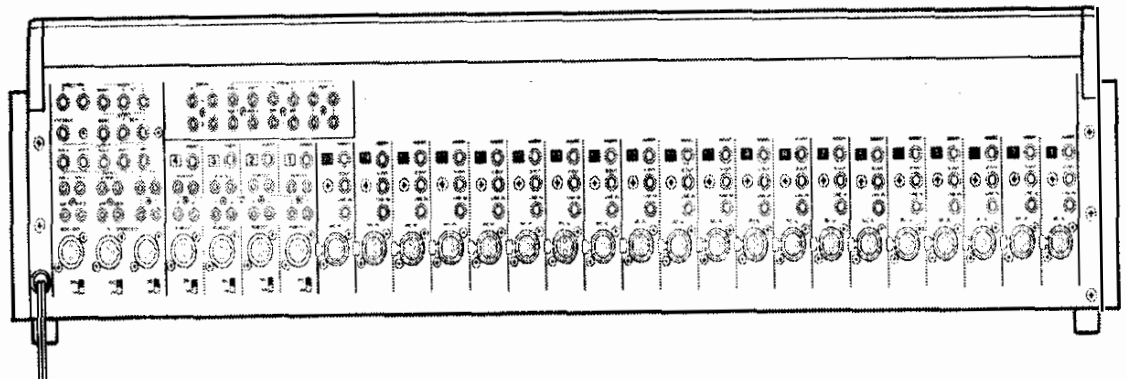
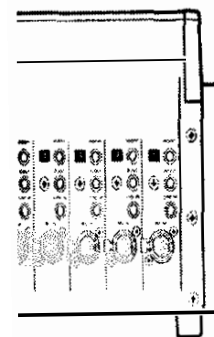
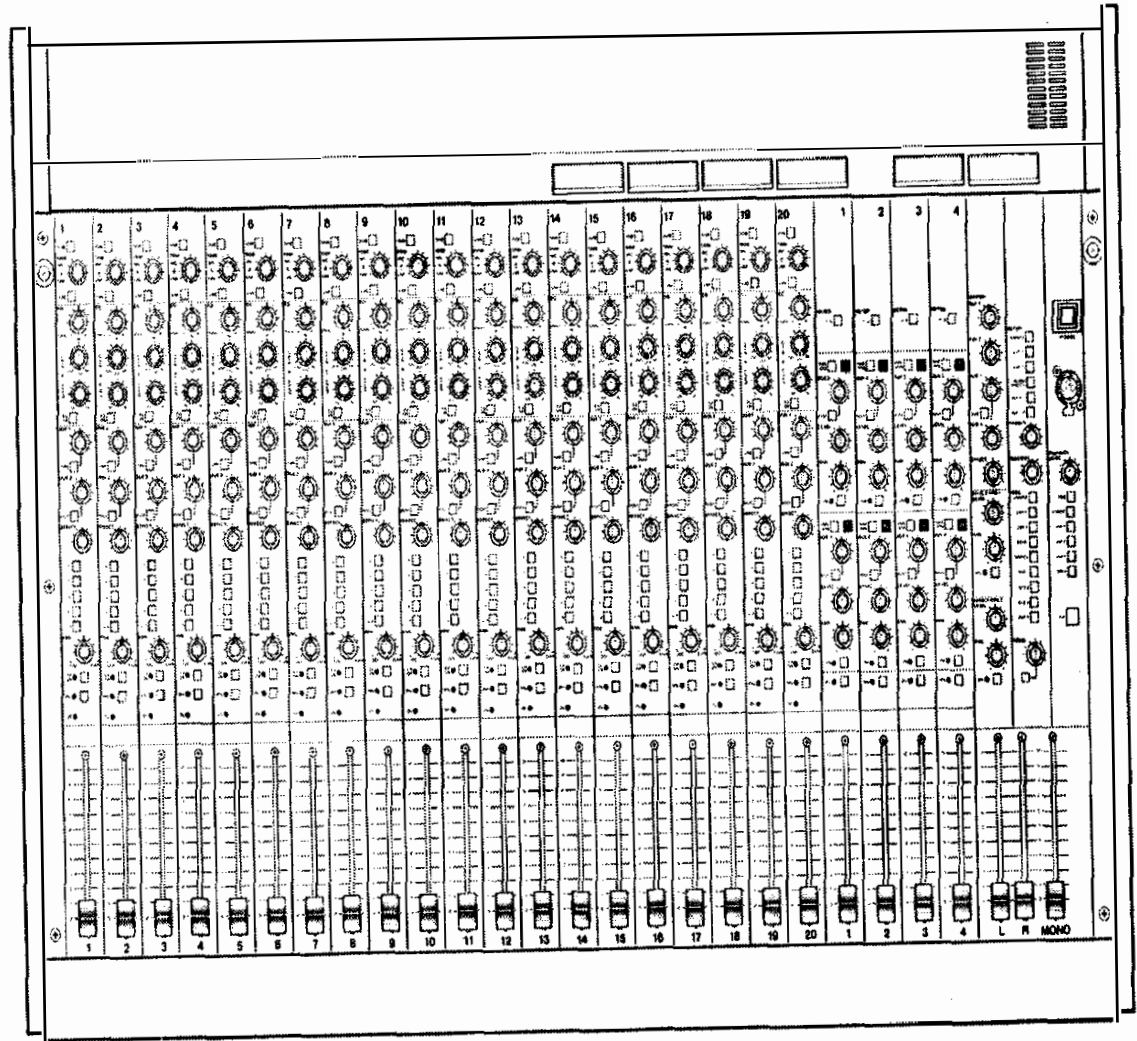
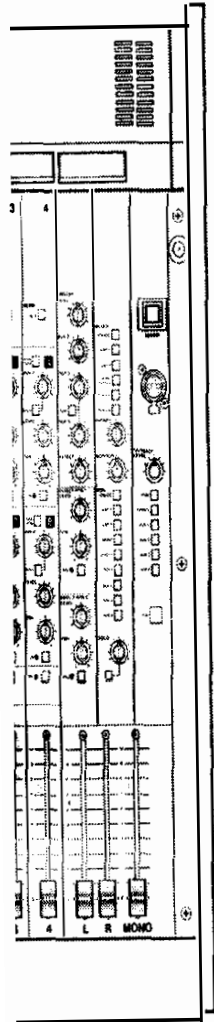
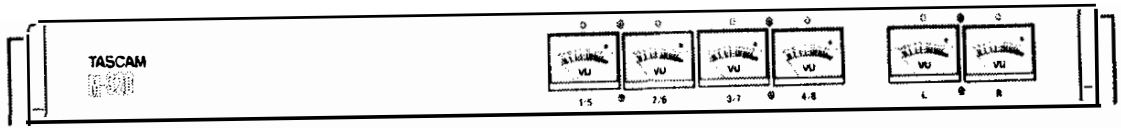
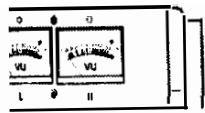

FUNCTIONAL SEQUENCE (M-312/M-320)

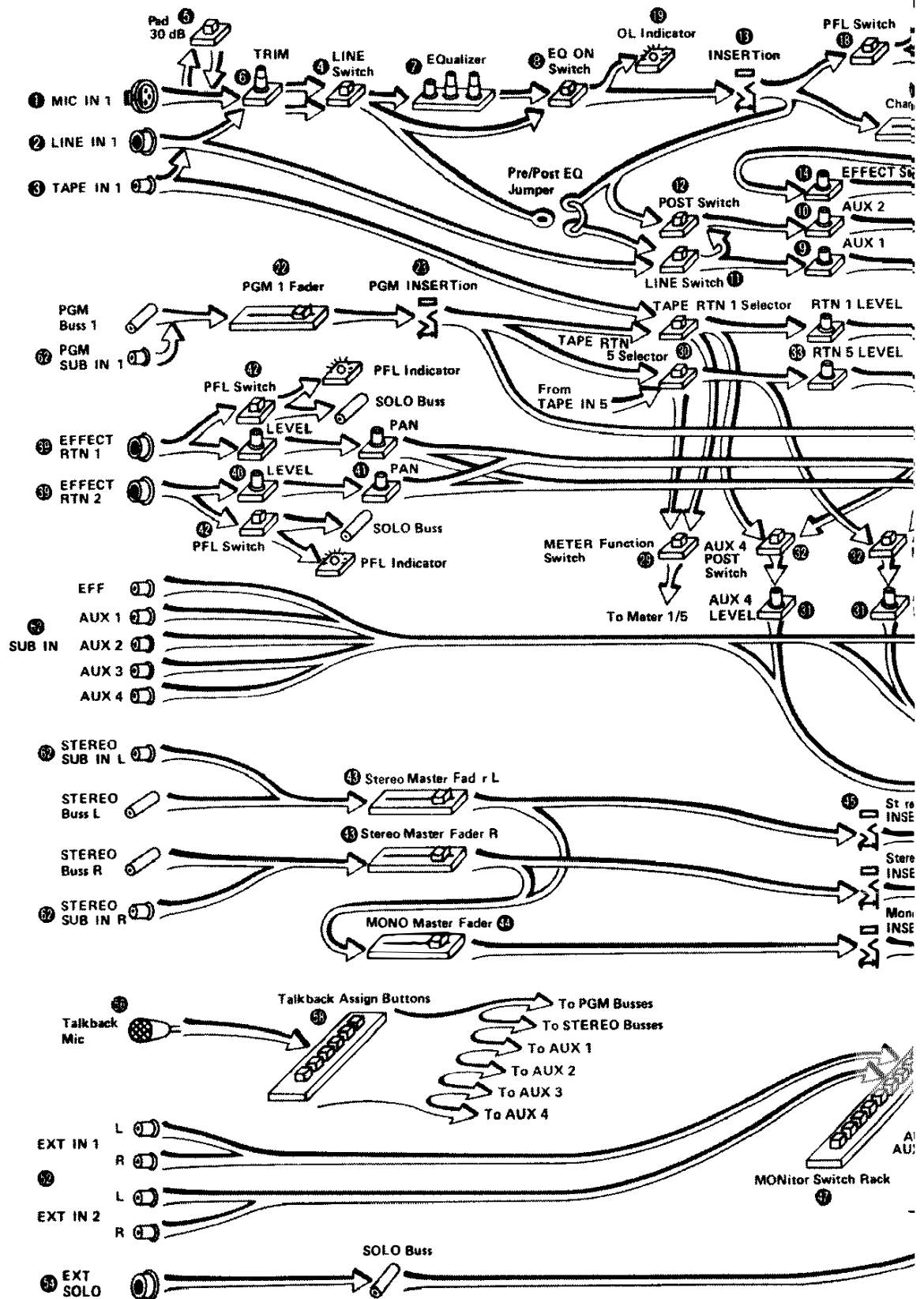

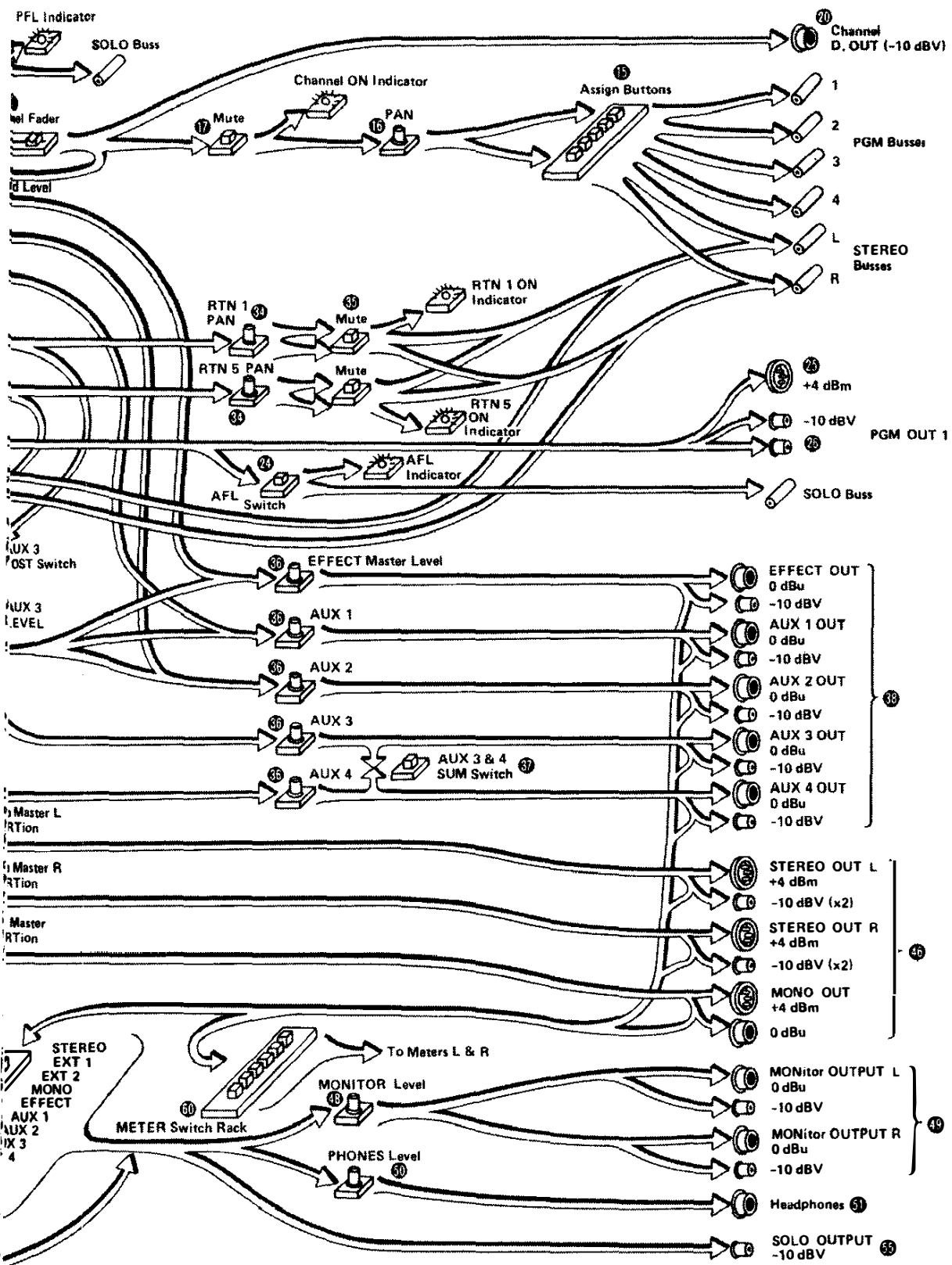

FUNCTIONAL SEQUENCE (M-308)

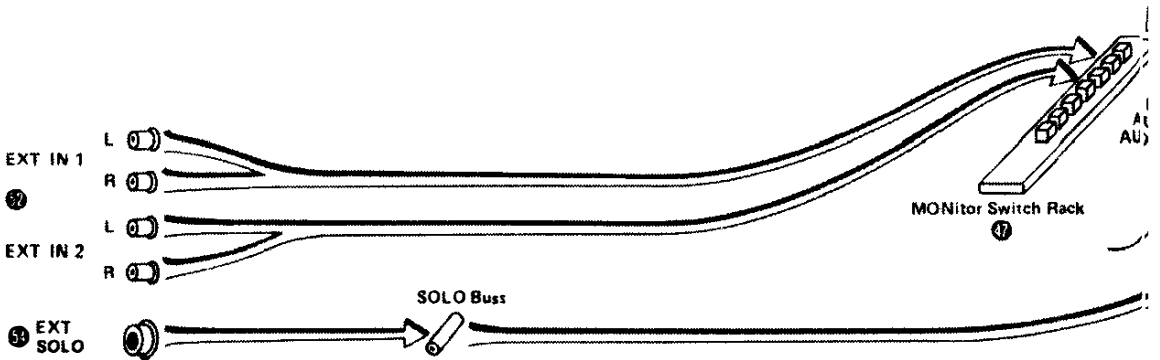
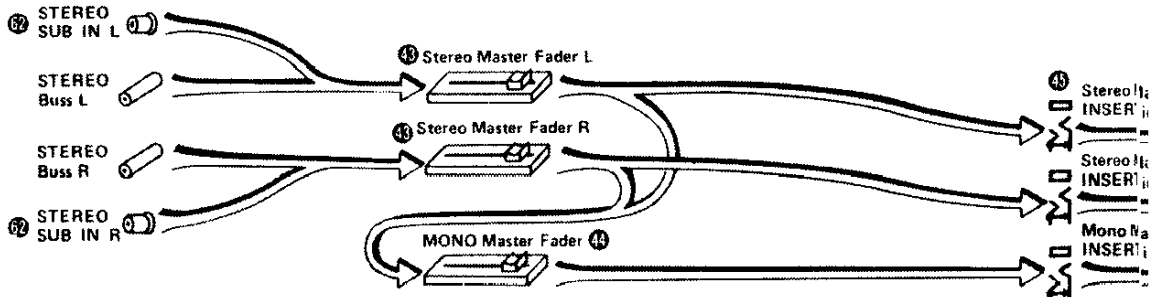
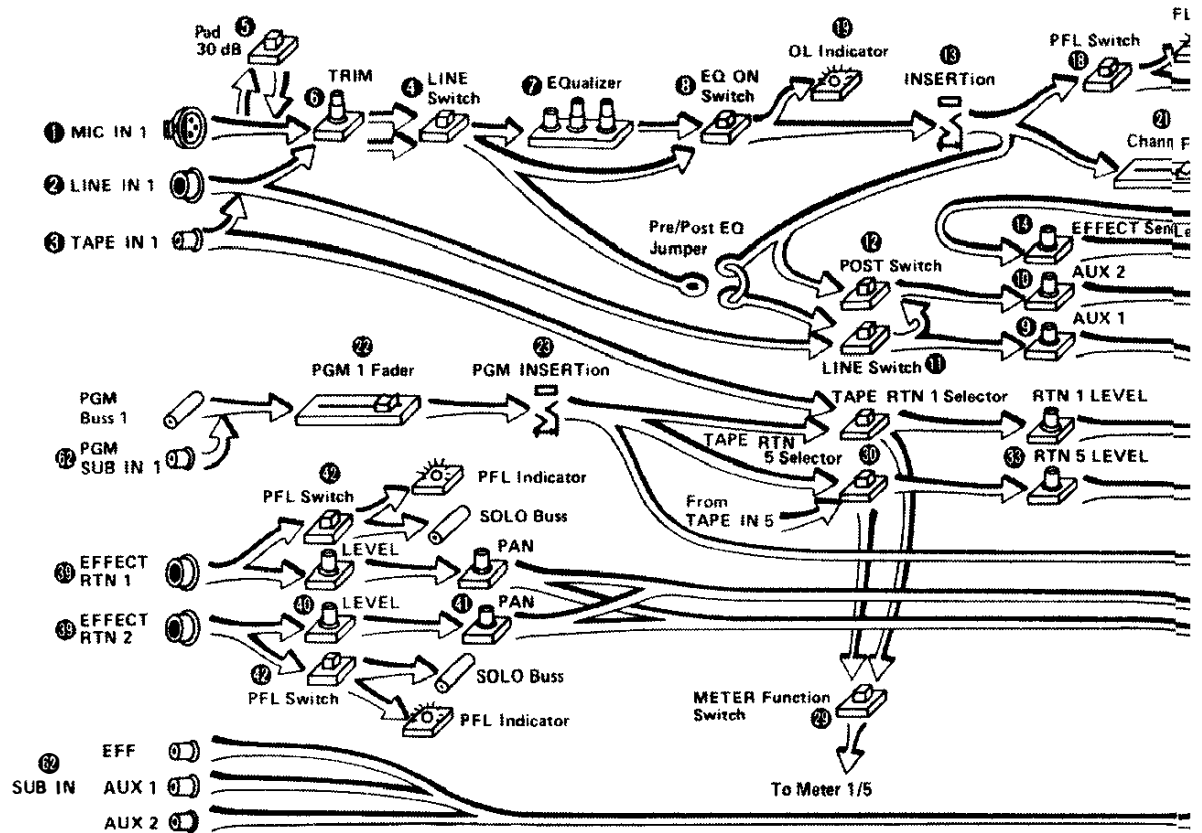

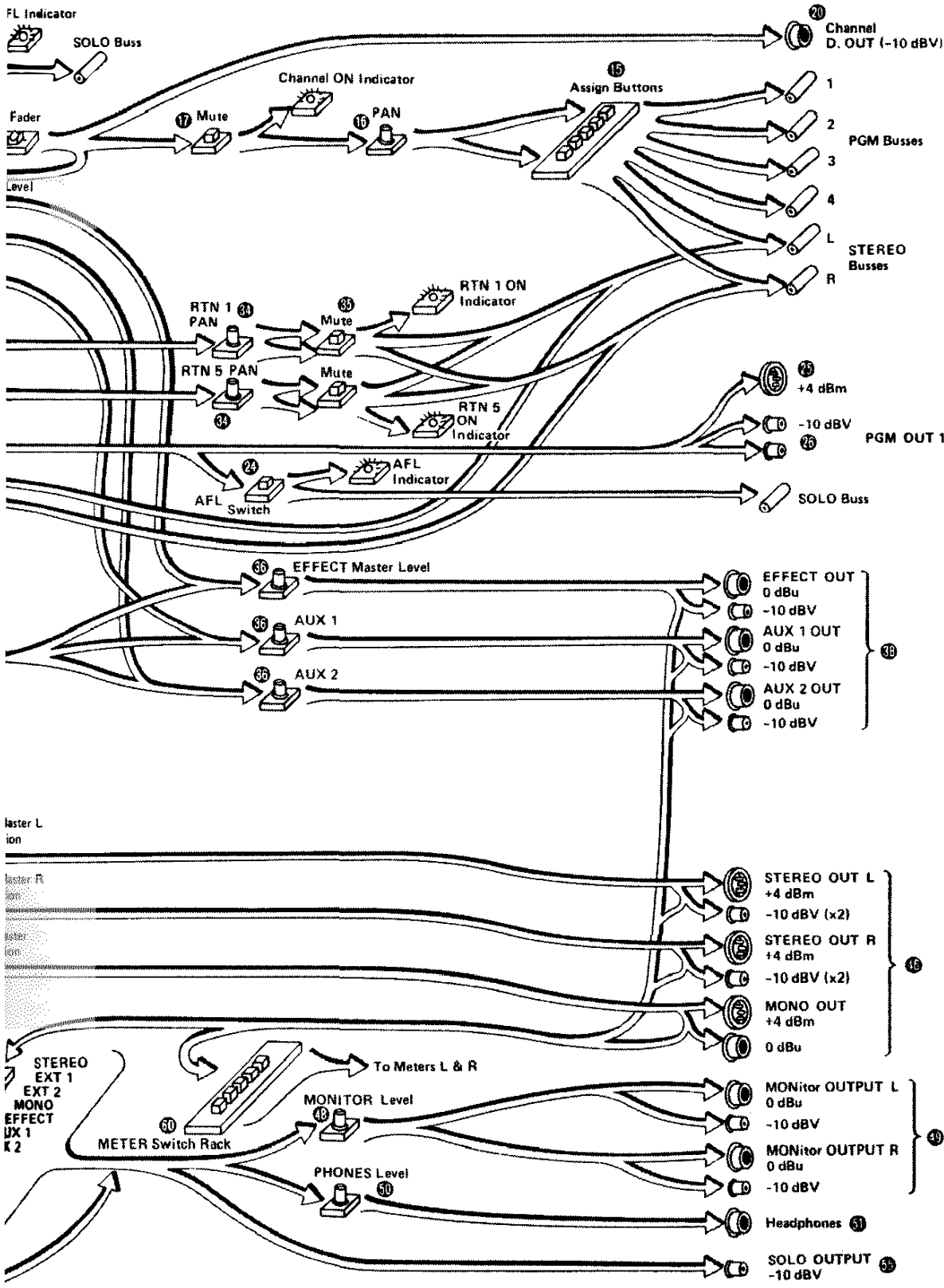

Understanding what's going on inside your equipment will help improve your sound. This manual as a reference book. You may not need to know all of what is here to begin, and it is certainly not necessary to memorize it, but do try to find the time to read it thoroughly at least once. That way you will be familiar with the contents and, if you need answers to any questions or solutions to problems, you will know where to turn.

Good luck with your sound!

INTRODUCTION

The TASCAM 300 Series Mixers were designed for maximum flexibility without compromising performance in any way.

They are equipped with a very flexible combination of features and functions so they can be successfully used in an extremely broad range of applications from small studio recording, to mixing for live sound reinforcement, to audio broadcast production, and video sweetening.

A mixer's value and usefulness can be determined by its flexibility. The more flexible a mixer, the greater its value to you. This flexibility however may make the mixer difficult to understand at first. With study and experience, you will find the 300 Series readily understandable, easy to use, and very flexible.

To understand the full capabilities of the 300 Series Mixers, it is important to realize the 300 Series are mixer systems comprised of multiple submix systems. These submix systems are designed to perform specific functions which allow the 300 Series to adapt to many different applications. These subsystems are: The MAIN MIX, the AUX 1 SUBMIX, the AUX 2 SUBMIX, the EFFECT SUBMIX, the EFFECTS RETURN SUBMIX, and the MONITOR SUBMIX. On the models 312 and 320, the MONITOR SUBMIX contains two (2) additional submix systems AUX 3 and AUX 4.

Each of these subsystems performs the same basic function: it takes signals in through its input, processes them, and sends them out through its outputs. The processes performed involve *gain control* and *routing* — in simple terms, “where” (both “where from” and “where to”) and “how much”. Every control found on the top panel, regardless of its specific label or system membership, performs one or both of these functions. Keeping this in mind may help overcome the inevitable intimidation caused by the apparent “sea of knobs” presented by your mixer.

These three illustrations will help you to understand the submix systems. The first is an illustration of the top panel controls. The second is a pictogram; this shows the controls laid out according to how they are wired (their *Functional* sequence). Note that the functional sequence is not the same as how the controls are

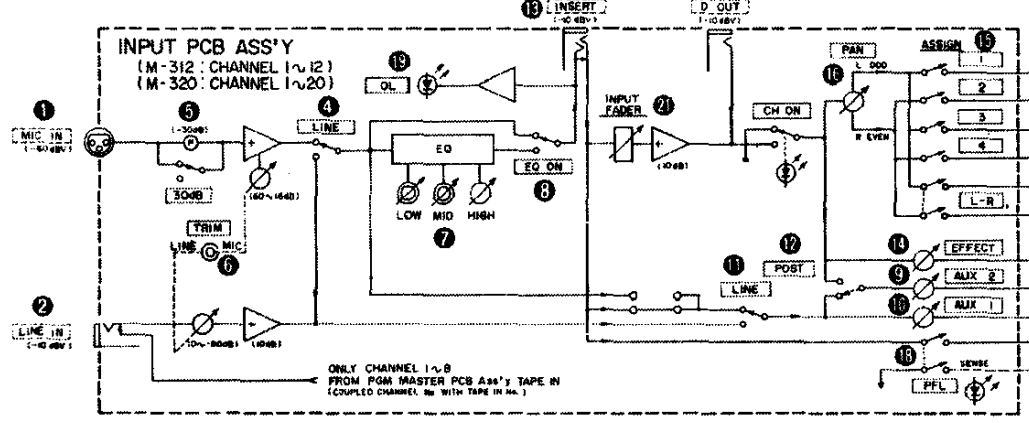
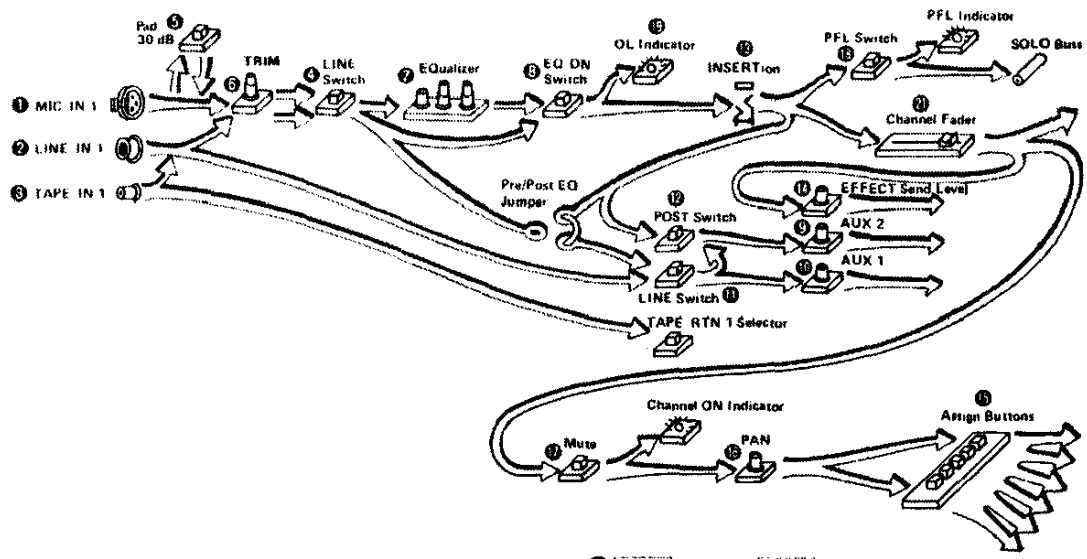
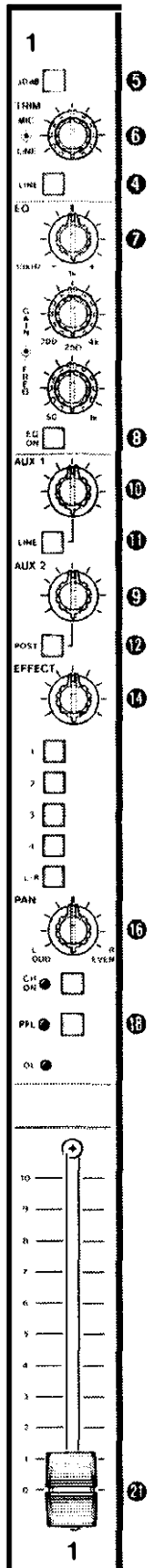

physically laid out. Also keep in mind that each symbol in the pictogram represents either a "where" or "how much" point, or, in the case of the PAN control, a "where AND how much" point. The third illustration, a simplified electrical sequence called a BLOCK DIAGRAM, is the same thing as the second illustration, except it offers a little more detail and uses different symbols. Using the numbers on these illustrations, you can see how a control knob on the first drawing relates to a function on the second drawing, and a symbol on the third. Studying these relationships will help you learn to read the BLOCK DIAGRAM. This is a valuable skill which will aid you in getting the most performance from your 300 Series Mixer. Experienced engineers can operate a sophisticated mixing console by using only the block diagram.

SYSTEMS INTRODUCTION

This manual presumes nothing about your past experience with the multi-channel process except a willingness to learn. An expert in the field might see the significance of a control or jack with just a simple statement of its location, but in this manual we will point out "the obvious".

There are numerous basic signal input connectors on the M-308, M-312, and M-320 mixers, as shown on this chart:

QUANTITY Connector Function	M-308	M-312	M-320
MIC(XLR) INPUT	8	12	20
LINE (1/4") INPUT	8	12	20
MULTI-PURPOSE TAPE RETURN INPUTS	8	8	8
EFFECT RETURN INPUTS	2	2	2
MULTI-PURPOSE BUSS INPUTS	9	11	11

Each specific feature and function is explained in the FEATURES AND FUNCTIONS section. Whenever possible, an explanation of when a specific control would be used will be given.

Main Mix System

The MAIN MIX system is the most complex of the submix systems. It is capable of accepting a number of different types of signals and processing them for a wide variety of applications. This is the primary mixing system. It is used to mix signal sources such as mics or tape playback, and route them to the PROGRAM (PGM) GROUPS and STEREO LEFT and RIGHT BUSSES. These busses can be used to provide signals to tape recorders, P.A. amplification systems, video recorder or any other sound system.

The EQUALIZER (EQ) network resides in the input channel section of the MAIN MIX system and is selectable. Since other subsystems may derive their input from the channel, either PRE (before) or POST (after) the EQ section, it is important to understand the various interrelationships of the multiple subsystems. In some cases, the "where" or "how much" of one subsystem may greatly affect the signal sent to another.

Each channel has either two or three input sources from which it may receive its input. As we will see later, each source can be used independently of the others, allowing the 300 Series to accept and mix multiple signals. For now, the input source (don't worry about what type of signal it is or where it comes from) will proceed through the channel strip. After processing, the signal is assigned to a BUSS or BUSSES. These may be the PGM GROUPS (1-4) or the STEREO LEFT and RIGHT or a combination of both, depending on the application. Multiple signals from the channels can be mixed together either in the PGM GROUPS or in the STEREO MASTERS, resulting in the finished mix.

Auxiliary and Effects Submix Systems

On the channel strips are three controls marked AUX 1, AUX 2 and EFF(ects). These represent three separate submix systems, all of which can perform various tasks. Think of these three subsystems as additional mixers; their respective titles are for identification purposes. These are handy for performing mixing duties separately from the MAIN MIX, although, in some cases, they derive their input from the channel itself.

The AUX 1 SUBMIX system derives its signals from either the channel strip in which it resides or from the corresponding LINE INPUT connector. On the first eight inputs, if the LINE INPUT is not used, the corresponding TAPE IN jack is automatically connected to the LINE INPUT circuit. The AUX 1 input source is determined by the LINE switch located next to the AUX 1 control. This determines whether the AUX 1 system input is taken from the LINE INPUT connector or from the channel. The AUX systems are independent of the channel or main mix system. Their input source choices are the same, but their actual source selection may be different. If the channel signal is selected, the signal is taken post (after) the EQ. If LINE is chosen, the LINE INPUT signal is sent to the AUX 1 control, bypassing the channel controls, even if the same signal is selected to the channel. Once sent to the AUX 1 BUSS, the signal is combined with any other AUX 1 signals. This composite signal is then controlled by the AUX 1 MASTER and sent to the AUX 1 OUTPUTS.

The AUX 2 submix system is similar to the preceding system, but offers a slightly different signal source choice. The AUX 2 signal input is determined by the POST switch. In the "up" position (PRE), the signal is the same as that selected for AUX 1, regardless of the AUX 1 choice. In the POST or "down" position, the AUX 2 system receives its signal from the channel post EQ and FADER. Thus, AUX 2 can be different from AUX 1 or the same, depending on the selection of the sources. As with AUX 1 the AUX 2 signals are summed and controlled by the AUX 2 MASTER control. The final signal mix is available at the AUX 2 OUTPUTS.

The next submix system is the EFF(ECTs) send system. Unlike the AUX 1 and 2 systems, the EFF(ECTs) system is dedicated; its signal source is always the channel. The signal is taken post fader, so whatever EQ and channel fader changes are applied to the channel signal will be apparent in the EFF(ECTs) signal as well. The composite EFF(ECTs) signal from all the selected send controls are sent through the EFFECTS BUSS to the EFFECTS MASTER control and on to the EFFECTS output jacks.

Effects Return System

The EFFECTS RETURN subsystem should be viewed as a pair of separate or extra line inputs. The specific reason for their inclusion is to allow signals sent from the EFFECTS send outputs to be modified by the chosen external device, then brought back to the MAIN MIX system. The EFFECTS RETURNS receive their signals from the EFFECTS RETURN inputs. Each of the jacks feeds signal to a separate LEVEL control. From here, the signals are distributed through the PAN controls and sent to the STEREO LEFT and RIGHT BUSSES. The EFFECTS RETURN system is dedicated; its signals always go to the MAIN MIX STEREO LEFT and RIGHT BUSSES.

Monitor System

The MONITOR submix system is an independent 8 input/2 output mixing system which can receive its inputs from either the PGM GROUPS or the TAPE RETURNS or a combination of the two. The MONITOR system is a necessary sub-

system for multi-track recording as it allows various signals to be heard or monitored during the actual recording process. Since these signals can be live, prerecorded or in combination, the engineer can use the MONITOR to aid in making critical artistic decisions regarding the final mix.

There are two horizontal rows of four MONITOR sections located above the PGM GROUP FADERS, each GROUP contains two MONITOR sections. The upper row contains sections 1, 2, 3 and 4, while the lower row, sections 5, 6, 7, and 8.

Each section consists of a TAPE RTN(/source) switch, a LEVEL control, a PAN control, and an ON switch. The TAPE RTN switch determines the signal source of the individual MONITOR section; either the corresponding TAPE RETURN input or the PGM GROUP in which the section resides. The LEVEL and PAN controls are used to set the signal level and distribution of the signal which is sent to the STEREO LEFT and RIGHT BUSSES. The ON switch allows the MONITOR output to be muted, stopping the signal from reaching the MAIN MIX.

Additionally, on the models M-312 and M-320, each MONITOR section contains an AUX send control and an AUX POST switch. In the upper row, MONITORS 1-4, the controls are labeled AUX 3, while the lower row, sections 5-8, contains AUX 4. Each is independent, sending signal to either AUX MASTER, 3 or 4.

The POST switch determines whether the AUX signal is derived before or after the MONITOR LEVEL control. If POST is chosen, the MONITOR ON switch will affect the AUX signal as well. These AUX systems allow the MONITOR mix to be utilized independently from the MAIN MIX. For example, a previously recorded signal could be added to new signals through the TAPE INPUT and the proper MONITOR section. Additionally, the same signal could be sent from the MONITOR through the AUX 3 or 4 system to an external effects device. This modified or "wet" signal could then be brought back to the MAIN MIX via the EFFECTS RETURN system. The two signals could be compared and blended, if desired, to create the proper sound quality.

Because of this flexibility, the MONITOR section can be used in a number of ways; it can be used as an Bx2 submix of external signals, or as a submix of up to eight various external and internal signals. On the M-312 and M-320, the two additional AUX systems also provide extra mixing capability as each can be used separately or summed to a mono configuration. The only limiting factors are the number of input choices and output configurations.

All these submix systems are interconnected and configured so as to provide tremendous programability, making the 300 Series incredibly powerful mixing consoles.

FEATURES AND FUNCTIONS

INPUT CHANNEL SECTION

1 MIC Input Connector

This is a three pin XLR-type connector for use with balanced signals with an impedance of from 50 to 600 ohms. While the connector is identified as a "MIC" input, in actuality it can be used for balanced LINE LEVEL signal as well.

By using the TRIM and 30 dB Pad Switch the MIC INput Connector can accept balanced line level signals of +28 dBm (19.5 V).

2 LINE INput

This 1/4" Phone jack is provided for use with unbalanced LINE LEVEL signals with a source impedance of 10 k ohms or less.

3 TAPE or RETURN INput – Channels 1-8 ONLY

These RCA-type phono jacks are NOT located with the rest of the channel input connectors, but can be found near the PGM OUTputs. Signals from these jacks are internally routed to channels 1-8 for remix and talent cues. To the monitor system for control room monitoring of 4 or 8 track recorders without having to change the controls or setting of the input channels.

See page 29 for Tape Return Signal Routes.

4 LINE Switch

This switch determines the signal to be routed through the input channels. In the "up" position (mic), the signal from the XLR is selected. In the LINE or "down" position, the signal in the channel will be either the signal from the LINE IN connector, or the TAPE INs on inputs 1-8 ONLY. The tape signal is automatically available if no signal is plugged into the 1/4" LINE INput jack.

5 Pad Switch

The pad switch allows the addition of a 30 dB resistive pad to the channels' MIC input level. This is provided for use and control of either extremely high mic signals or when the XLR is used with balanced line level signals.

6 TRIM

This dual concentric control is used in conjunction with the OL (OverLoad) Indicator. TRIM will reduce the level of those input signals which would otherwise overload the channel's electronics. Each channel has a MIC TRIM and a

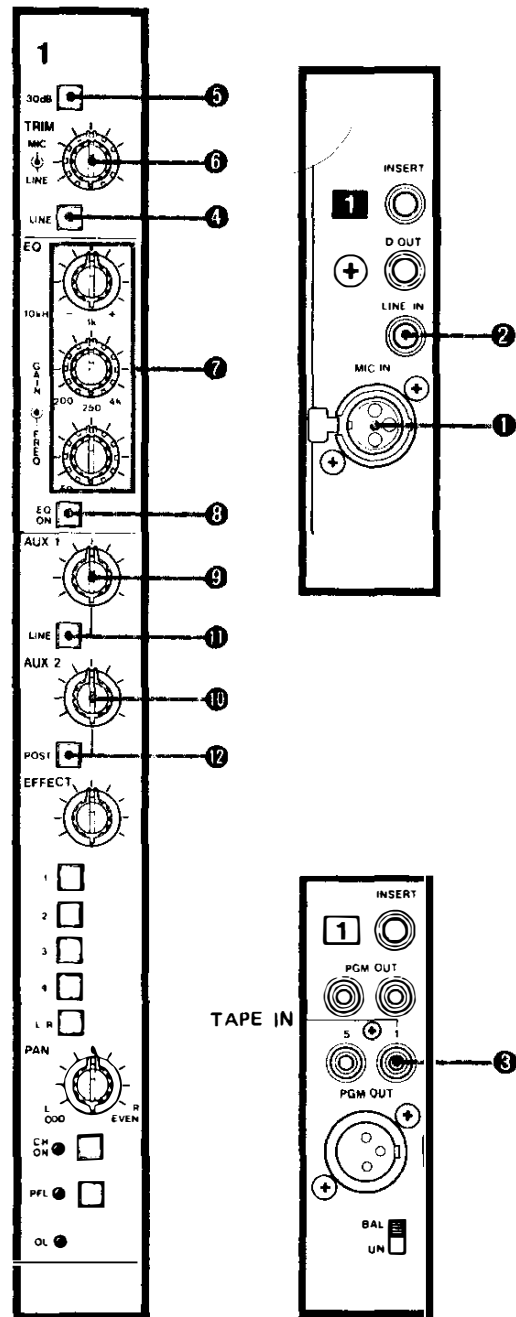

LINE (Tape) TRIM to avoid having to reset the TRIM and/or Fader when switching between MIC INput and LINE INput (Tape).

a. MIC TRIM – Upper Knob

This control provides variable attenuation for signals from the XLR connector. If additional signal reduction is needed, for extreme-

LINE IN Signal Routes

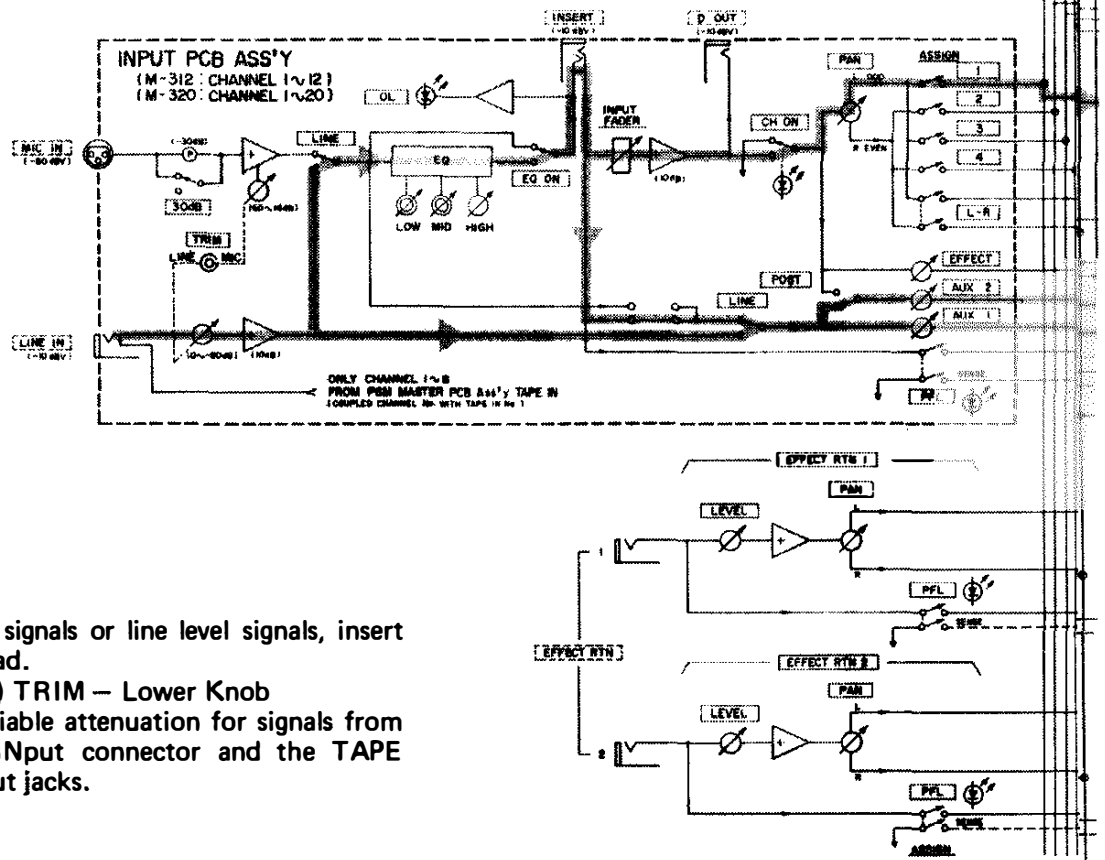

ly high Mic signals or line level signals, insert the 30 dB Pad.

- b. **LINE (Tape) TRIM** – Lower Knob
Provides variable attenuation for signals from the LINE INput connector and the TAPE Return INput jacks.

7 Equalizer

The 300 equalizer or EQ section offers the user a comprehensive control network for the adjustment of the tonal structure of the signal. The EQ system is divided into three sub-sections: High Frequency (controlling all signals above 10 kHz), Midrange (for control over signals from 200 Hz to 4 kHz), and Low Frequency (providing control over frequencies from 1 kHz down to 50 Hz and below).

The high frequency section is shelving type and allows the 12 dB boost or cut at 10 kHz.

The midrange section is a quasi-parametric or sweep-type network. The concentric lower knob selects the center frequency from 200 Hz to 4 kHz. The upper knob provides for 15 dB of boost or cut at the chosen center frequency. The band width, also known as the "Q", is fixed at 7.6 of an octave, or a "Q" of 1.6.

The low frequency section is also a quasi-parametric, sweep-type network. The center frequency range is from 1 kHz down to 50 Hz. The gain range is 15 dB of boost or cut. The band width is 7.6 of an octave, corresponding to a Q of 1.6.

Both the mid and low frequency networks are peak-dip designs.

For more information on EQ see page 44.

8 EQ ON Switch

This switch allows the signal to be sent to, or routed around, the EQUALIZER section. When the switch is in the down position, the signal in the channel is sent to the EQ for processing. Use the "up" or "off" position if the signal in the channel has already been sent through an equalizer or requires no tonal adjustment, it can be routed to bypass the EQ electronics entirely.

9, 10 AUXiliary 1 & 2 Controls

The AUX systems are non dedicated buses which can be used for Headphone Cue, Effect Send, Echo Send, Monitor/Foldback, Broadcast Remote Feed, and reference Recording Busses. These two controls provide identical functions. Each determines the level of signal sent to their

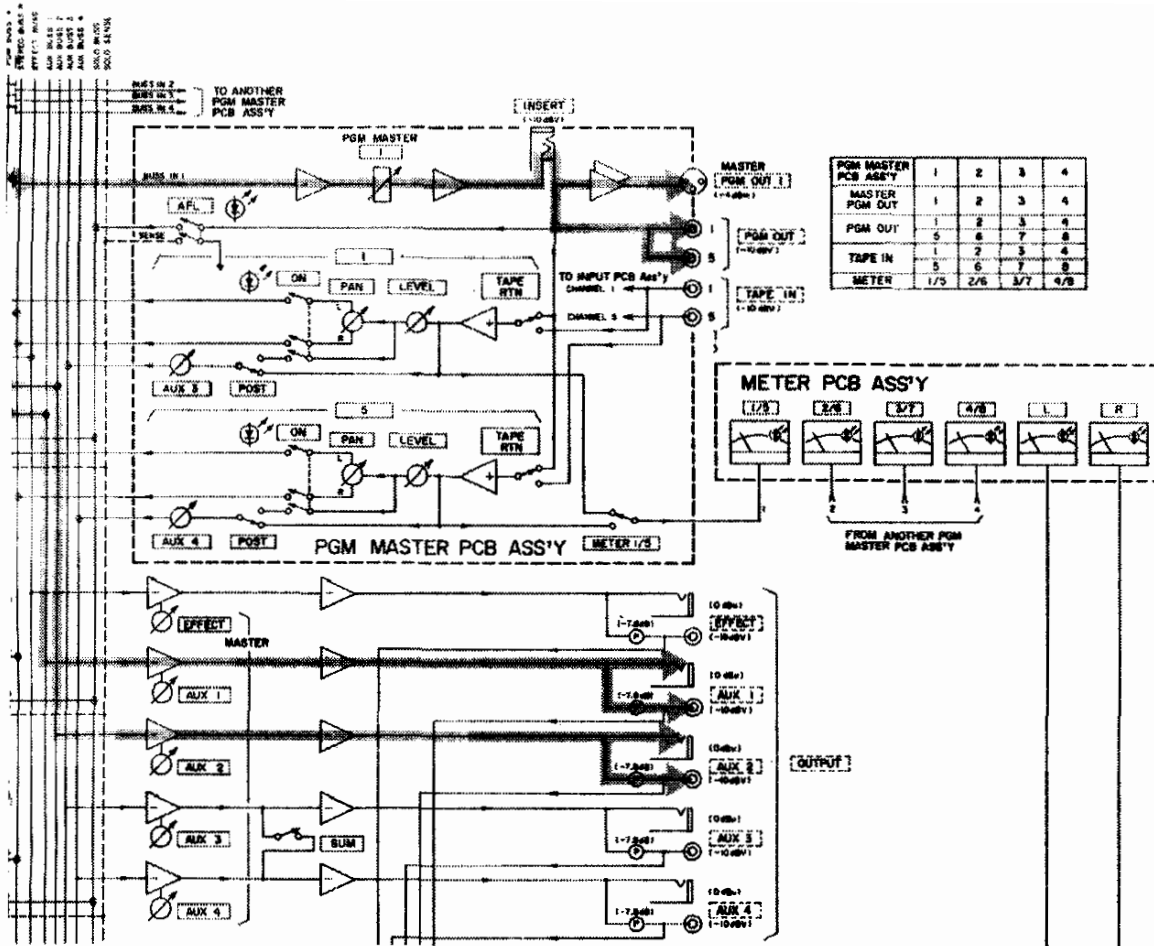

respective circuits or busses. Each control can receive and process a signal from a different source or point within the channel's signal path.

11 , 12 AUXiliary LINE and POST Select Switches

These two switches determine the source of the signals sent to the AUX controls. The LINE switch, located beneath the AUX 1 control, allows the selection of signal between either the LINE input or the channel. The LINE signal can be selected even if the channel signal is derived from the MIC input. If the channel signal is selected, the signal is taken just after, or "post", the EQ. Additionally, there is an internal jumper provided to enable the channel signal to be derived ahead of or "pre" EQ. Once the LINE switch has been set, the signal flows to the AUX 1 control and to the POST switch. This switch offers the choice of either the signal selected by the LINE switch or

a signal taken from the channel after (post) the FADER and ON switch. The signal selected here is sent to AUX 2. Thus, by using these two switches, AUX 1 can be LINE, CHANNEL pre-EQ or CHANNEL post-EQ, while AUX 2 can be the same as AUX 1 or can be CHANNEL post-FADER.

- a. Pre — Pre-fader signal is taken from the channel before the fader, so it is not affected by the channel's fader setting, making it useful for stable Cue mixes.
- b. Post — Post-fader signal is taken from the channel at a point right after the ON switch. Because post-fader signals are subject to any change in the channel's fader setting, they are usually preferred for effects or echo mixes.
- c. LINE (Tape Input — Channel 1-8 Only) — Selects the TAPE Return Input if no connector is connected to the LINE input terminal. It is the preferred signal to set up

the performer's Cue mix for overdubbing which requires the ability to combine the already recorded tracks with the new material. By monitoring the recorders outputs while in the Sync mode, you will have both the new and pre-recorded material available for independent Cue mix. When checking the overdub, the Cue system will now be fed all of the recorded tracks at relatively the same mix levels that occurred during the recording.

d. **LINE** — Selects the Channel's line input. The LINE position is very useful as a way to return submixes or effects into the AUX system.

Each of these position can be used for various reasons, and this ability to select the signal source can be extremely beneficial during complex mixing situations.

① INSERTion Jack

This 1/4" Phone jack is actually two connectors in one. The jack is a stereo "break" design and is wired in a standard TIP-RING-SLEEVE configuration. The channel's signal, or SEND, is wired to the connectors TIP contact. The INSERT or RECEIVE, which allows outside signals back into the channel path, is wired to the RING (middle) contact. The shield connection for both signals is the SLEEVE. The jack contains a mechanical switch, or break, which opens, or "breaks", the normal contact between the TIP and RING portions, whenever a plug is inserted into the jack. This mechanical switching technique is called "normalling". A connector is "normalled" if it provides the signal to be disconnected when a plug is inserted, but

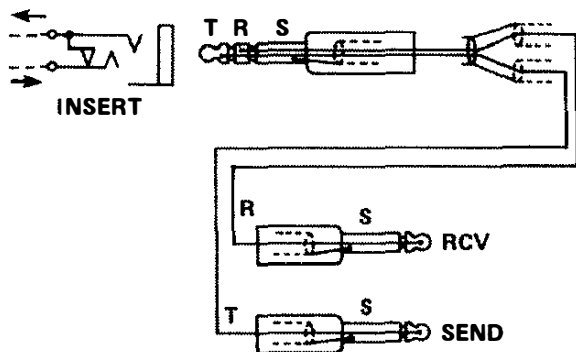

- T — Tip, send signal
- R — Ring, receive signal
- S — Sleeve, ground

allows normal signal flow if no connector is plugged in.

This jack is located on the rear panel just above the MIC IN connector.

② EFFECT Send Control

The EFFECT control is similar to the AUX controls, except it cannot be switched to receive signals from various points. The EFFECT signal is always derived post-FADER and ON.

③ Channel Assign Switches

The five push-button switches allow the selection of each of the four PROGRAM busses independently plus the STEREO MASTER busses. Any combination of busses can be selected simultaneously. The switches receive their signal after the channel PAN control, with the PROGRAM 1 & 3 and the STEREO LEFT busses receiving the output from the PAN LEFT, while PROGRAMS 2 & 4 and STEREO RIGHT receiving the output of PAN RIGHT.

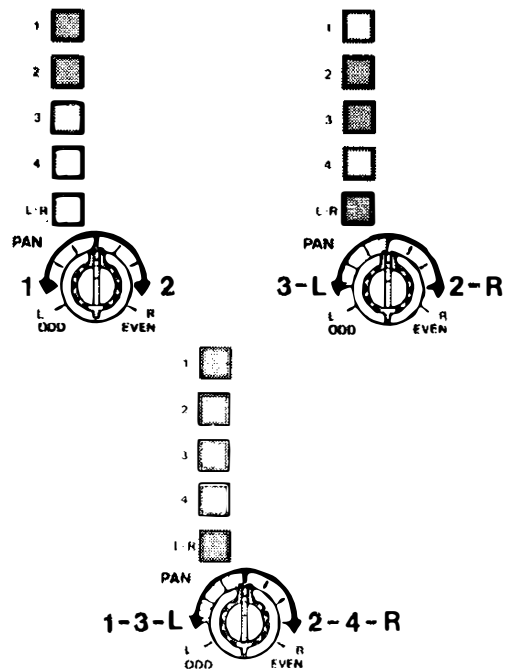

④ PAN Control

As described above, the PAN (short for "panorama") control acts as a left-to-right balance device for "placing" the channels signal in the stereo spectrum. Placing the PAN control in the center or 12 o'clock position sends the signal to both the left and right busses equally.

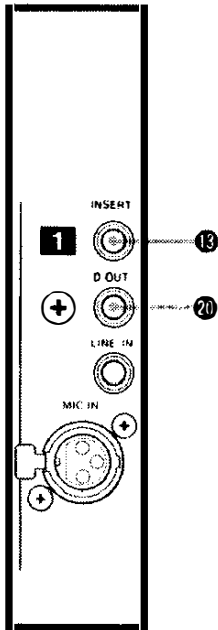
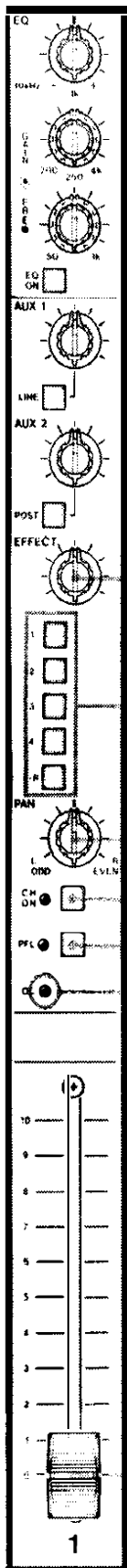

17 Channel ON Switch

This switch determines the status of the channel's signal. Pressing the switch allows the signal to flow to the PAN control, and also, to the EFFECTs and AUX post-fader send point. When the channel is "ON", the LED next to the switch will be lighted, giving a positive visual indication of the specific channel's status.

18 PFL (Pre Fader Listen) Switch

This is a locking switch which, when pressed, provides access to the channel signal ahead of, or pre, the fader. This allows the signal to be accessed even if the fader is closed or if the channel is turned off. The signal is sent to the SOLO buss. Next to the PFL switch is a LED indicator which lights when the function is in use.

19 OL (OverLoad) Indicator

If excessive signal levels are present in the channel, the OL LED will light. The overload detection circuit is designed to monitor the signal and to fire the LED whenever signals of 15 dB (3 dB prior to distortion) are detected.

20 Direct OUTput Jack

Located on the rear panel directly below the INSERT jack, the Direct OUTput provides access to the channel signal in its final form. The signal present is derived post-fader, pre-channel ON, allowing the channel signal to be taken out of the mixer for processing, to make up additional post-fader mixes or to feed a one mic per track signal to the recorder.

21 Channel Fader

The Channel Fader determines the final signal level sent to the various post-fader derived circuits. The 100 mm linear design provides fast visual reference to the overall channel level relative to other channels, while the gradient scale markings provide accurate relative level indication. The Faders are individually mounted for easy service. Additionally, the mounting screw spacing is standard, allowing in-field replacement with after-market units if desired.

Solo (PFL/AFL) Signal Routes

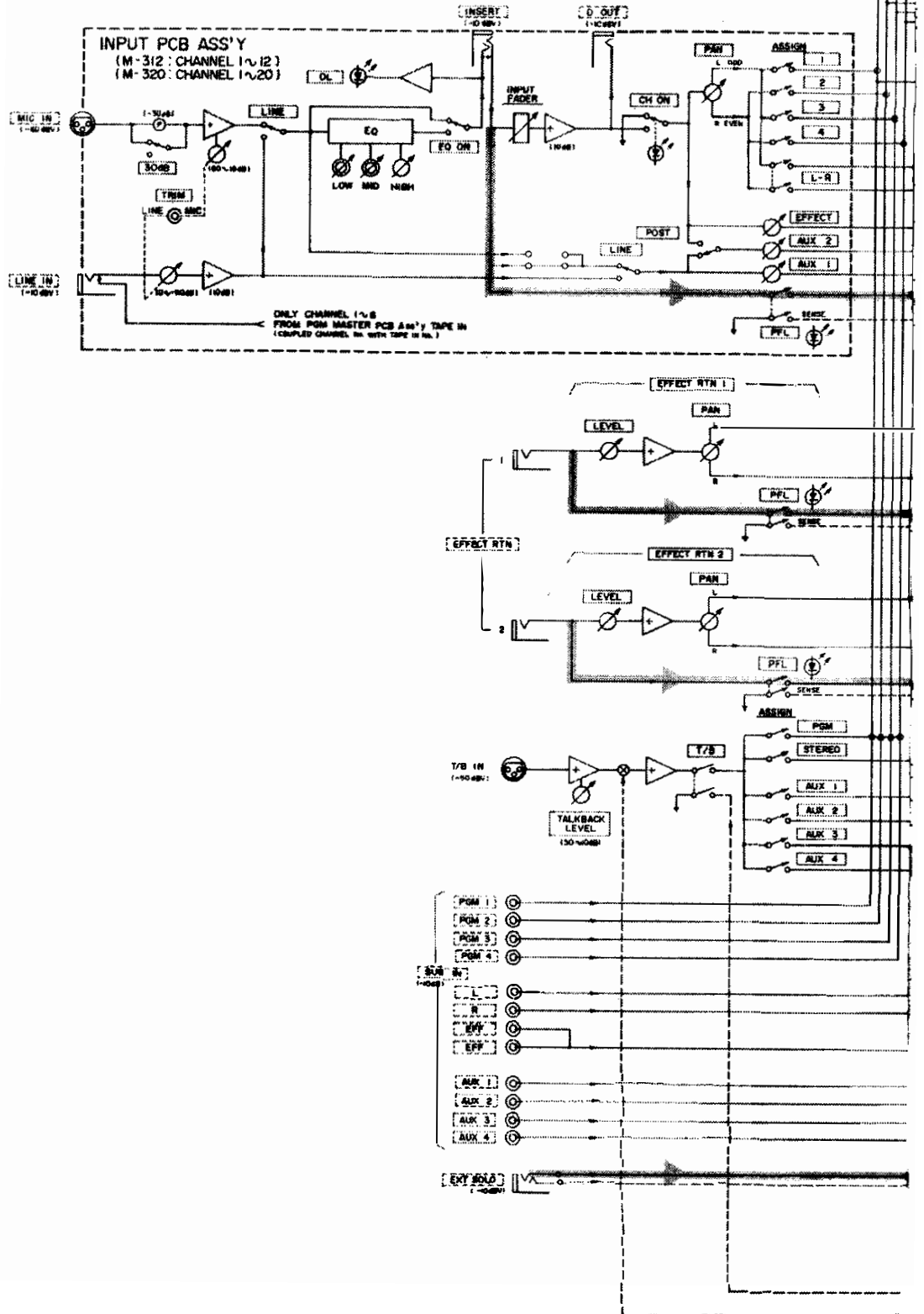

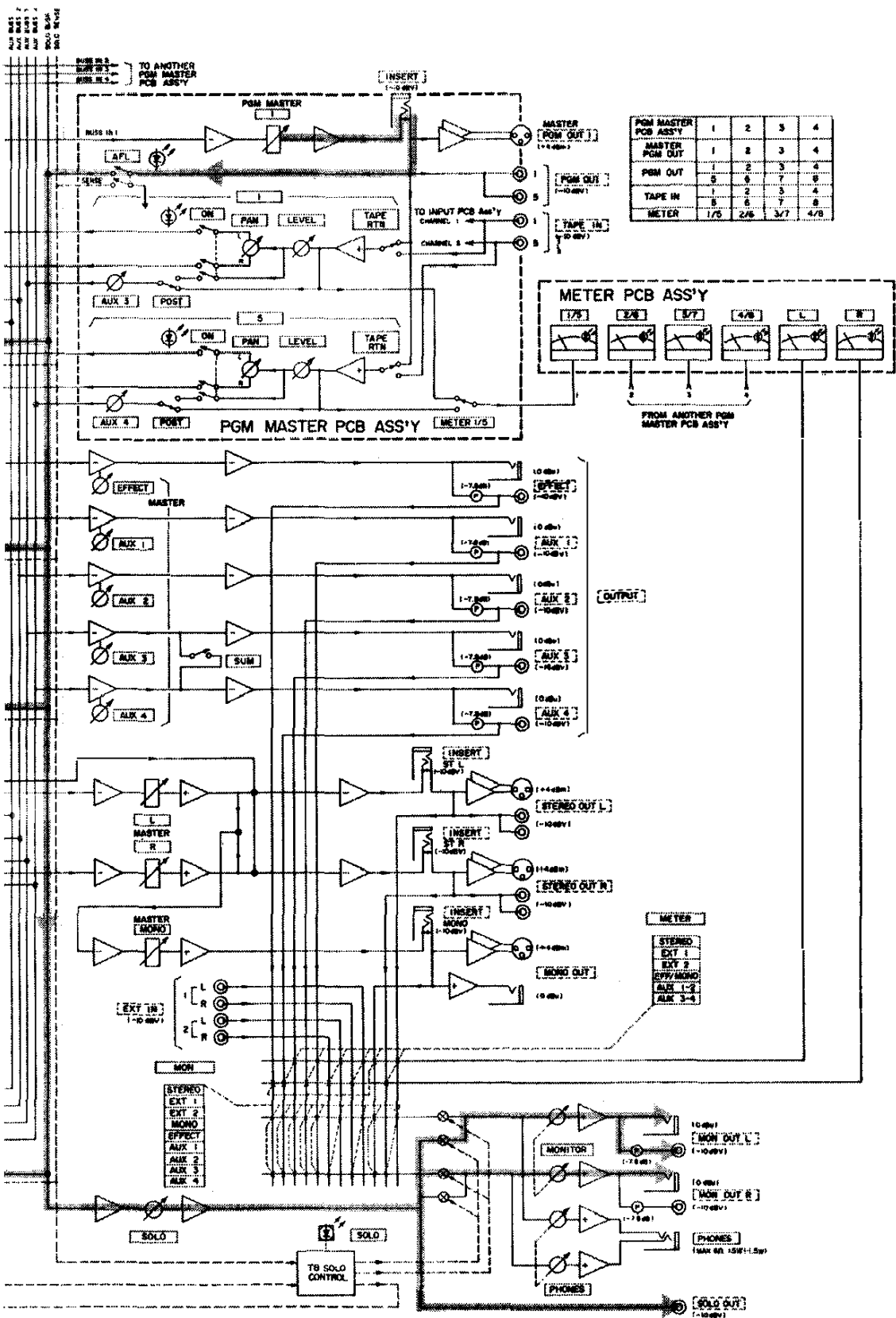

PGM MASTER PCB ASS'Y	1	2	3	4
MASTER PGM OUT	1	2	3	4
PGM OUT	1	2	3	4
TAPE IN	1	2	3	4
METER	1/5	2/6	3/7	4/8

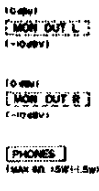
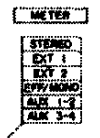
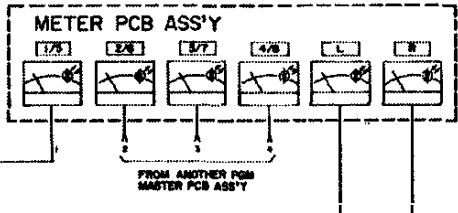

PROGRAM MASTER SECTION

② Program Master Fader

Each of the four PROGRAM sections contain a 100 mm Fader for the setting of the final PROGRAM output level. As in the case of the Channel Faders, each carries gradient scale markings for relative level indication.

③ Program INSERTion Jack

As in the channel section, the PROGRAM SECTIONS are fitted with a standard 1/4" stereo break jack, providing POST FADER access to the signal flow within the respective PROGRAM. The input (ring) side of this jack provides the final PROGRAM signal to the TAPE RTN SELECT SWITCHES, AFL circuit and, of course, the various PROGRAM final outputs.

④ AFL (After Fader Listen) Switch

The selection of this locking switch sends the PROGRAM signal to the SOLO buss, providing the operating engineer access for monitoring the final PROGRAM content. The take-off point is after the PROGRAM FADER and INSERTION JACK.

PROGRAM (GROUP) OUTPUT SECTION – REAR PANEL FEATURES

⑤ PGM OUTput Connector – XLR

This XLR type connector is designed to provide an electronically balanced output derived post fader from programs 1-4. Below each XLR is a two position slide switch which allows the signal to be selected as either balanced or unbalanced, as required. When in the balanced position, the output level is +4 dBm with pin 3 high and pin 2 low and pin 1 shield. In the unbalanced position, the output remains at +4 dBm, however the pinout changes as follows: Pin 3 hot, pin 2 and pin 1 shield.

⑥ PGM OUTputs – RCA

These RCA-type jacks provide the same signal as found at the XLR connector, except it is always unbalanced and the nominal level is -10 dBV. The PGM OUT RCA and XLRs are connected in parallel and can be used simultaneously.

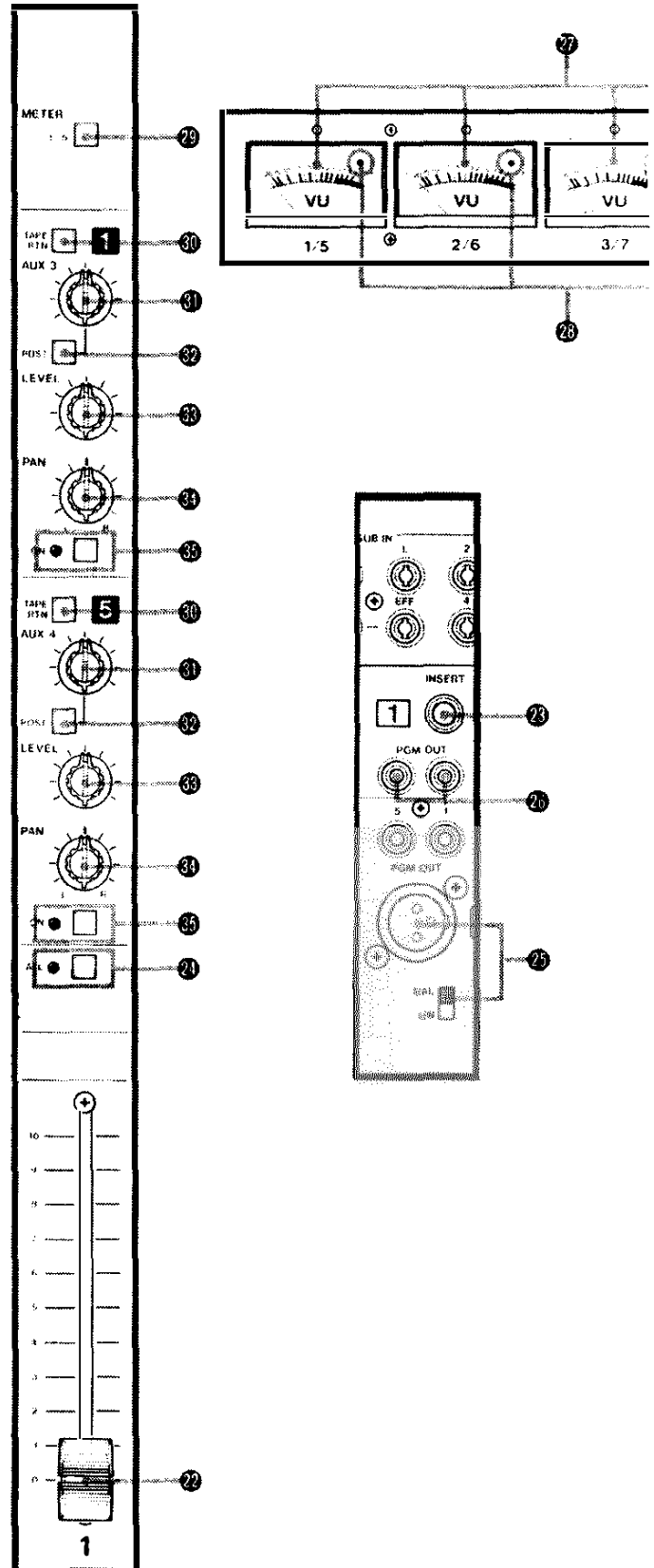

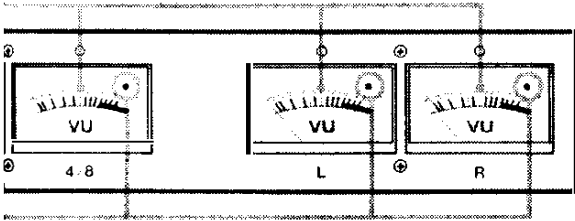

METER SELECT AND TAPE RETURN MONITOR SECTION

⑦ VU Meters

Each of the first four meters display either the level of the PGM busses or that of the TAPE RETURNS. The metering source is determined by the METER Select Switches (see #29).

The two meters on the right, L and R, allow monitoring the level of the signals selected on the METER Select Switch Rack (#60).

All these six meters respond to the *average* signal level using standard volume unit ballistics, and do NOT show peak levels.

⑧ Peak LEDs

The light emitting diode provided for each meter will react much more quickly than the meters, and is set to "flash" 10 dB above "0 VU". They are telling you the truth about the REAL level. The "average" level shown on the VU meter is not always a safe concept. Rely on the peak LEDs, the meters are only a guide.

⑨ METER Select Switches

Each of the four (4) PGM VU meters can be switched to provide visual monitoring of either the PGM busses or the TAPE RTN's. When the switch is in the "up" position, the meter receives signal from either the corresponding PGM buss or from TAPE RTN's 1-4, depending on the position of the TAPE RTN SELECT switch. When the Meter Select switch is in the "down" position, the meters can receive signal from either the PGM buss or TAPE RTN's 5-8. Once the metering source is selected, the meters will follow the selection of the TAPE RTN Select switches in the TAPE RETURN MONITOR sections (see below).

⑩ TAPE RTN Select Switch

When pressed, this switch connects the specific TAPE RETURN to the corresponding TAPE MONITOR section, allows access of the returning signal to the METER, and provides signal to a specific AUX SEND control. If the returning signal is not chosen, the switch replaces the TAPE signal with that of the PROGRAM. Thus, the MONITOR and AUX sends can receive and process signals from either of the TAPE RETURNS or the PROGRAM.

⑪ AUX 3, AUX 4 Send Controls (M-312 & M-320 ONLY)

Each MONITOR section contains one of these controls. AUX 3 is accessed from TAPE RETURNS 1-4, while AUX 4 derives signals from TAPE RETURNS 5-8. Since the AUX 3 & 4 receive their signals after, or post, the TAPE RTN Switch (see the previous description), the setting of this switch determines the signal processed by the AUX SENDS.

⑫ AUX 3 & 4 POST Switch (M-312 & M-320 ONLY)

This switch allows the AUX SENDS to receive signal either before (pre) or after (post) the respective MONITOR LEVEL control (see below).

⑬ Monitor LEVEL Control

Once the signal source has been determined and selected by the TAPE RTN switch, the overall volume is set by the MONITOR LEVEL control. This level is then sent to the AUX POST circuit and the MONITOR PAN control.

⑭ Monitor PAN Control

As with the channel PAN controls, the MONITOR PAN determines the left-to-right placement of the signal in the MONITOR system. The PAN sends the signal to the STEREO LEFT and RIGHT BUSSES.

⑮ Monitor ON Switch and LED Indicator

This switch allows the signal in the MONITOR system to pass to the STEREO BUSSES and on models M-312 and M-320, to the AUX POST circuit. The LED indicator is lit when the switch is in the "ON" position (down). The switch does NOT affect the signal sent to the AUX PRE circuit.

AUX 1 – 4 Signal Routes

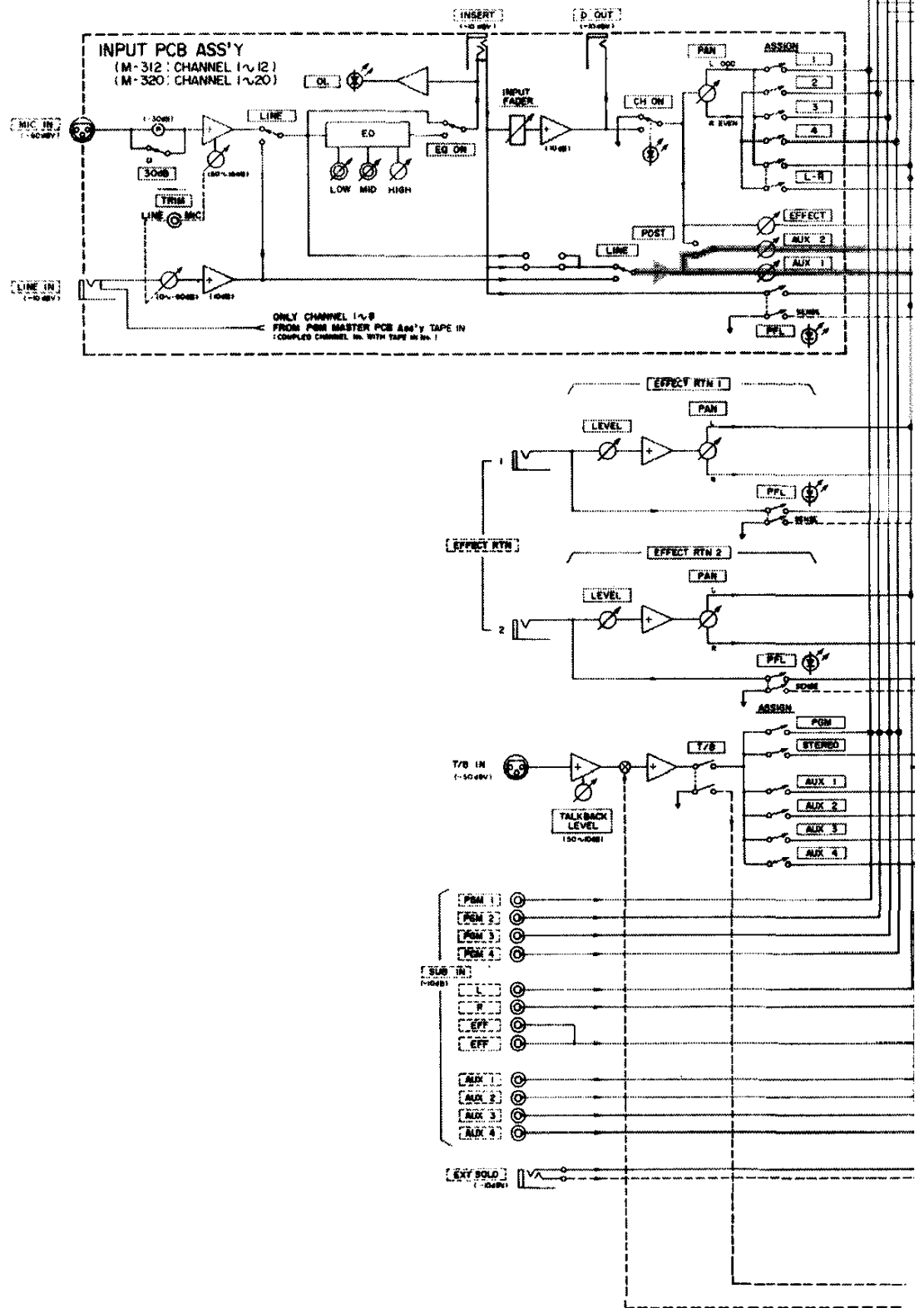

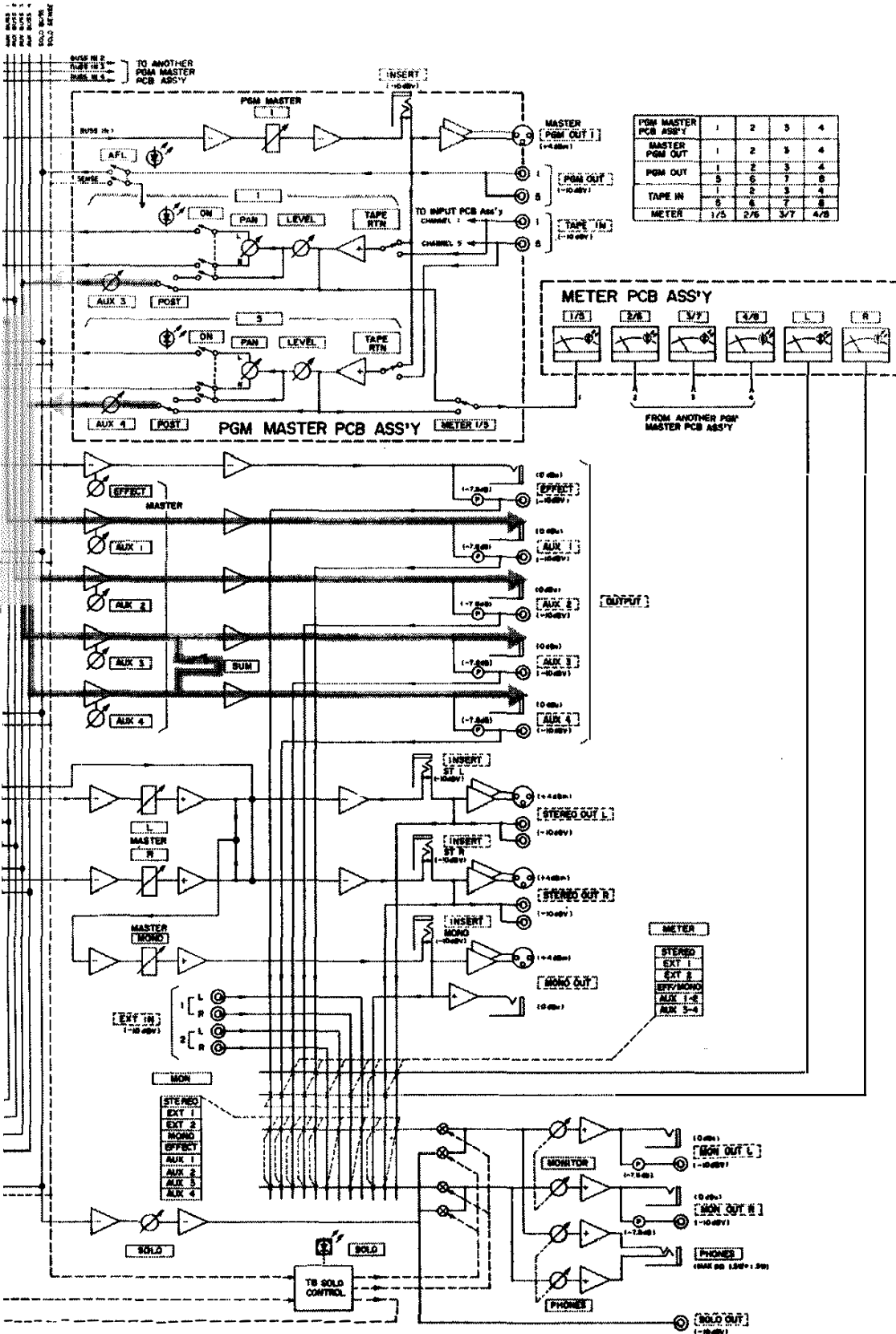

PGM MASTER PCB ASS'Y	1	2	3	4
MASTER PGM OUT	1	2	3	4
PGM OUT	5	6	7	8
TAPE IN	1	2	3	4
	5	6	7	8
METER	1/5	2/6	3/7	4/8

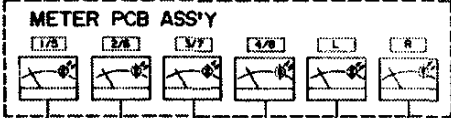

FROM ANOTHER PGM MASTER PCB ASS'Y

METER

STEREO EXT 1
EXT 2
EFFECT/MONO
AUX 1-4

MONITOR
MON OUT L
MON OUT R

PHONES
SOLID OUT

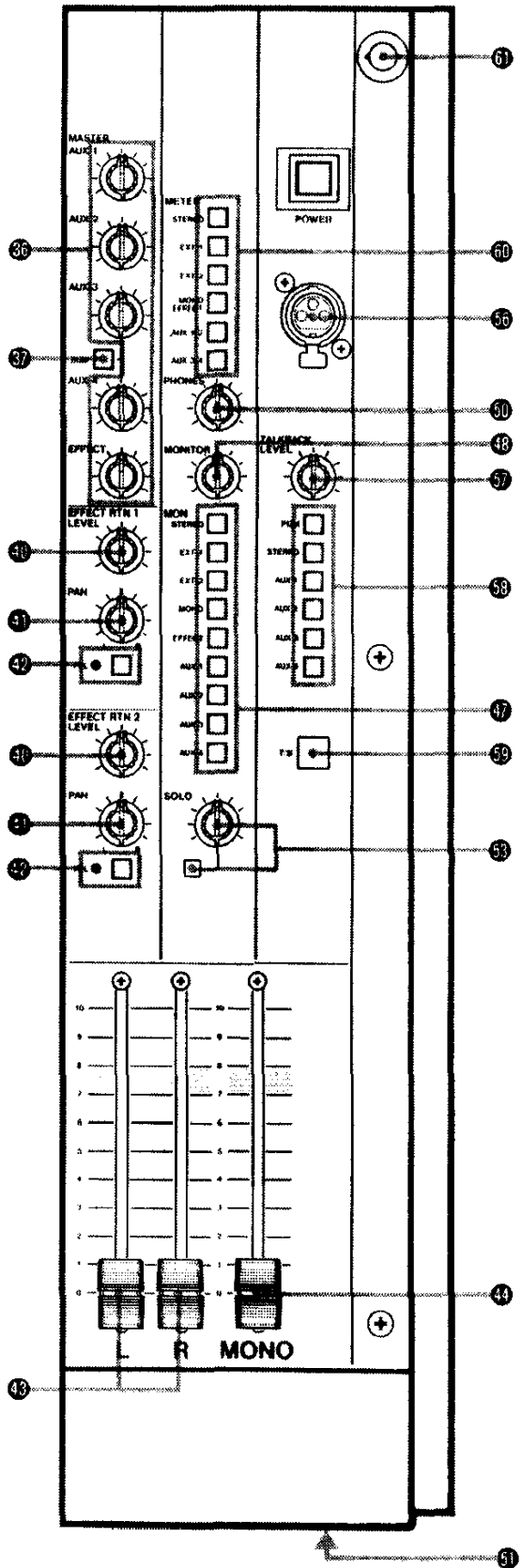

AUXILIARY AND EFFECTS MASTER SEND CONTROLS

36 MASTER Level Controls

Each of the two (M-308) or four (M-312 or M-320) AUX systems and the EFFECTs system has its own independent MASTER LEVEL control, allowing up to five different AUX or EFF signals or mixes to be controlled. Each of these rotary controls functions in an identical manner, sending its finalized signals to the respective outputs.

39 AUX 3 & 4 SUM Switch (M-312 & M-320 ONLY)

This switch allows the signals from AUX 3 & 4 MASTER controls to be summed together, creating a monaural mix of the signals which is then available at both the AUX 3 & 4 OUTPUT jacks.

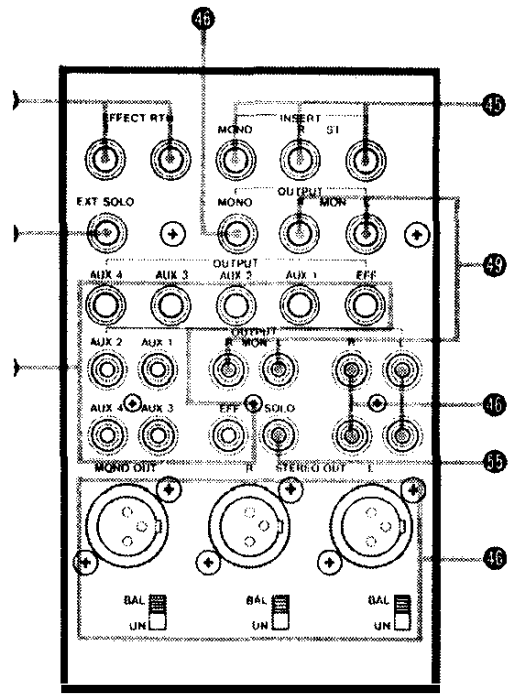
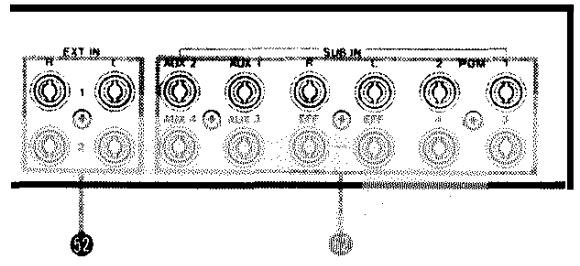

Ⓢ AUX and EFFECTS OUTPUTS

This series of 1/4" Phone jacks provide output from the AUX & EFF busses found on the 300. Each jack provides an independent line level signal, whose output level references are: 1/4", 0dBu; RCA, -10 dBV, from its corresponding MASTER CONTROL.

EFFECTS RETURN SYSTEM

The 300 Series is equipped with two independent EFFECTS RETURN networks. Each is identical in both features and function.

Ⓢ EFFECT RTN

These two 1/4" Phone jacks provide the ability to bring external line level signals into the STEREO BUSSES. The signals may be from effects devices, such as echoes or reverbs, or may be independent signals generated elsewhere.

Ⓢ EFFECT RTN LEVEL Control

The LEVEL control allows the returning signal to be adjusted, thus providing the ability to match existing signal levels.

Ⓢ EFFECT RTN PAN Control

The EFFECT RTN PAN determines the left-to-right balance of the returning signal sent to the L & R STEREO BUSSES.

Ⓢ EFFECT RTN PFL Switch

When pressed, the EFFECT RTN signal is taken off before the action of the EFFECT RTN LEVEL control and delivered to the SOLO buss.

An LED indicator next to the PFL switch lights when the function is in use.

STEREO AND MONO MASTER SECTIONS

In the preceding sections, some of the subsystems eventually send the processed signals to the STEREO BUSSES. These busses, in turn, deliver the combined signals to the STEREO MASTERS.

Ⓢ Stereo Master Faders

Both the left and right MASTER FADERS are 100 mm units, designed to provide accurate level control.

Ⓢ MONO Master Fader

This control receives its signal from both the LEFT and RIGHT MASTER FADERS. This summed signal provides the user the ability to create monaural masters from stereo masters, or to create both simultaneously. Like the other FADERS, the MONO MASTER is a 100 mm design.

Ⓢ INSERTion Jack, Stereo and MONO Masters

As with the other INSERTion jacks found in the channels and program masters, these jacks provide the ability to alter the signal with external devices, such as equalizers, limiters, etc. The access points are POST FADER.

Ⓢ STEREO and MONO OUTPUTS—XLR & RCA PHONO

The XLR connectors provide an output level of +4 dBm from both the LEFT and RIGHT stereo BUSSES and the MONO BUSS. Each connector is paired with a two position slide switch which allows the selection of either a balanced or unbalanced configuration of the signal. The RCA phono jacks provide the same signals but at a lower level, -10 dB. The signal at the MONO OUT XLR connector is also available at the OUTPUT MONO 1/4" Phone jack.

MONITOR SECTION

The MONITOR system in the 300 Series is very comprehensive, allowing the operator to select and hear virtually any signal or combination of signals found in the console.

Ⓢ MONitor Select Switches

This switch rack allows selection of either seven (M-308) or nine (M-312 & M-320) separate signal sources or busses. In addition, where the selection is a left-right pair, such as the STEREO busses, the separation is maintained throughout the MONITOR. This allows in-place monitoring of critical material.

The selections are; STEREO, EXTERNAL 1, EXTERNAL 2 (both are left-right pairs), MONO, AUX 1, AUX 2 and EFFECT. Additionally, AUX 3 and AUX 4 are available on the M-312 & M-320.

Ⓢ MONITOR Level Control

This dual control adjusts the level of the signal selected by the MONitor Select Switch.

49 MONitor OUTPUTs

These 1/4" Phone and RCA phono jacks provide stereo output signals from the MONitor SELECT SWITCH RACK.

50 PHONES Level Control

This determines the final signal level available to the headphone amplifier. The signal is derived before the MONITOR LEVEL control, but is otherwise the same.

51 Headphone Output Jack

This is located on the front of the mixer below the arm rest. This circuit is designed to be used with 8 ohm stereophones.

CAUTION;

MONO (2 WIRE) HEADPHONES WILL CAUSE CIRCUIT FAILURE. If your headphones have this connector, don't use them



(1/4" phone 2-connector)



(1/4" phone 3-connector)

Your headphone connector must have 3 sections to be safe. While accidents do happen, and protection circuits have been built in, use of mono/2 wire headphones will eventually cause circuit failure (2 to 3 minutes). Using the 2 wire connector shorts out one of the amplifiers driving the headphones, which will cause it to burn out.

52 EXTERNAL INPUTs

These RCA phono jacks are provided on the rear panel so that any stereo input such as an additional submix, a half-track master recorder or cassette machine can be connected and can be switched in and out of monitor system, using the EXT 1 and 2 MONitor Select Switches.

53 SOLO Level Control and Indicator

The SOLO BUSS receives signal from the channel PFL switches, from the program AFL switches and EFFECT RTN PFL switches. The LEVEL control allows the signal to be adjusted to the desired level. Below the control is the SOLO indicator. This large, red lamp lights whenever any PFL or AFL switch is pressed. This indi-

cates; 1) A signal is present in the buss, and, 2) The MONITOR and HEADPHONE circuits are switched from their normal signal, as determined by the MONitor switch, and are receiving, instead, signal from the SOLO circuit. This one-switch, automatic switching logic, allows fast, easy changes in the monitor signal and is very useful during complex mixing sessions.

54 EXT SOLO

This 1/4" Stereo Phone jack provides external access to the SOLO Buss and the Solo Control signal line. This connector when combined with the SOLO OUTPUT jack of another 300 series mixer allows the two SOLO systems to be combined.

This is a valuable tool when assembling various pieces of equipment for studio production work. For this, connect the first mixer's SOLO OUTPUT and EXT SOLO to the second mixer's EXT SOLO.

55 SOLO OUTPUT Jack

This RCA Phono connector provides a SOLO Buss output from the mixer. It is essential when two mixers are to be cascaded, patched together to work as one larger mixer.

Combining the two SOLO systems

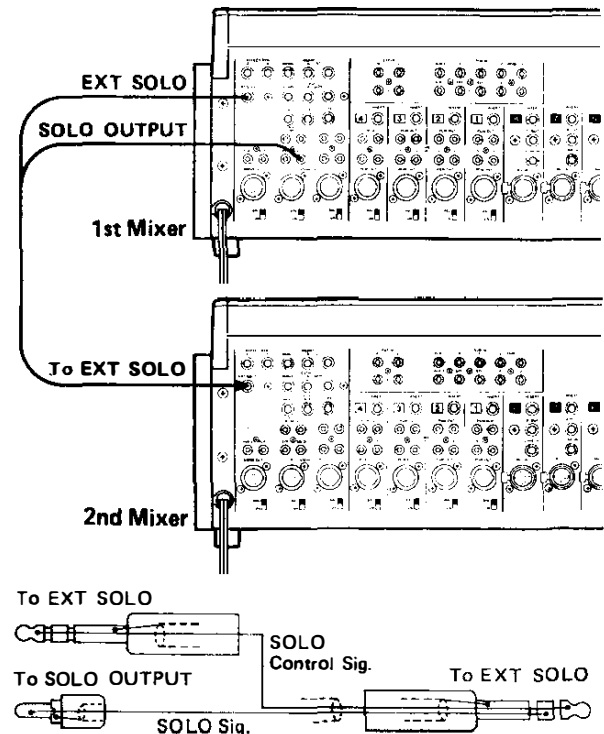

56 TALKBACK MIC Connector

This female XLR-type connector allows a dedicated talkback mic such as the TASCAM model MC-701G to be added to the M-312 and M-320 mixers.

57 TALKBACK LEVEL Control

This rotary volume control determines the signal level sent from the TB mic to the selected busses.

58 TALKBACK SELECT Switches

These six (6) switches provide bussing of the Talkback signal to the following internal circuits; PGM Busses 1-4, STEREO Left and Right busses, AUX 1, AUX 2, AUX 3, and AUX 4. Any combination of switches may be selected simultaneously.

59 TALKBACK MASTER Switch

This large, protected, momentary switch connects the output or the Talkback section to the select switches. Pressing this switch also sends an electronic control signal to the Solo Control circuit which mutes the normal signal and replaces it with the Talkback signal. This eliminates any possibility of feedback loops through the Monitor system.

60 METER Select Switch

The last two meters, L and R, display levels of the signals selected on the METER select switch rack.

The meter L displays the signal level at the STEREO OUT L, EXT IN 1 L, EXT IN 2 L, EFFECT OUTPUT, AUX 1 OUTPUT or AUX 3 OUTPUT, when the respective METER select switches are pressed. The meter R displays the signal level at the STEREO OUT R, EXT IN 1 R, EXT IN 2 R, MONO OUT, AUX 2 OUTPUT or AUX 4 OUTPUT, depending on the METER select switch settings.

61 Light Terminal

This "BNC" connector is provided, 1 on the 312 and 2 on the 320 for the attachment of Little Lights. The connectors supply 12 V, 5 W max.

ADDITIONAL REAR PANEL FEATURES

62 SUB IN Jacks

These jacks all perform the same function – they provide access into the intermediate stages of various busses. The signals are added to the buss just prior to the master level or output fader control. This allows externally produced and mixed signals to be added to the internal signals being mixed; thus, the signals from another 300 Series or similar mixer could be patched into the yours. The second mixer would then become the master, controlling the final signals of both units.

PGM SUB IN Jacks 1-4

Provide access to the four sub-groups.

R and L SUB IN Jacks

Provide access to the main STEREO BUSES.

EFF SUB IN Jacks

Provide access to the EFFECT SEND buss.

AUX SUB IN Jacks

Provide access to the AUX 1 and 2 busses on the M-308. And, the AUX 1, 2, 3 and 4 busses on the M-312 and M-320.

EXT SOLO and SENSE

This 1/4" stereo phone jack allows external solo signals and control signals to be added to the on-board system. The Tip connector accepts the external solo signal, the Ring connector accepts the external solo control signal while the sleeve is ground.

TAPE INs

Each Program section carries the TAPE IN connectors for two tape tracks or inputs. PROGRAM 1 has TAPE INs 1 & 5, PGM 2 has 2 & 6, PGM 3 has 3 & 7, and PGM 4 has 4 & 8. These are RCA-type IN jacks and are designed to handle line signals with a nominal level of -10 dB. As mentioned previously, these signals are routed to 1) the corresponding LINE IN connector (usable only if no connection is made to the 1/4" LINE IN jack), and 2) to the respective TAPE RTN select switch. Thus, returning tape signals can be selectively routed to inputs, input auxiliaries, or to the tape monitor sections.

Tape Return Signal Routes

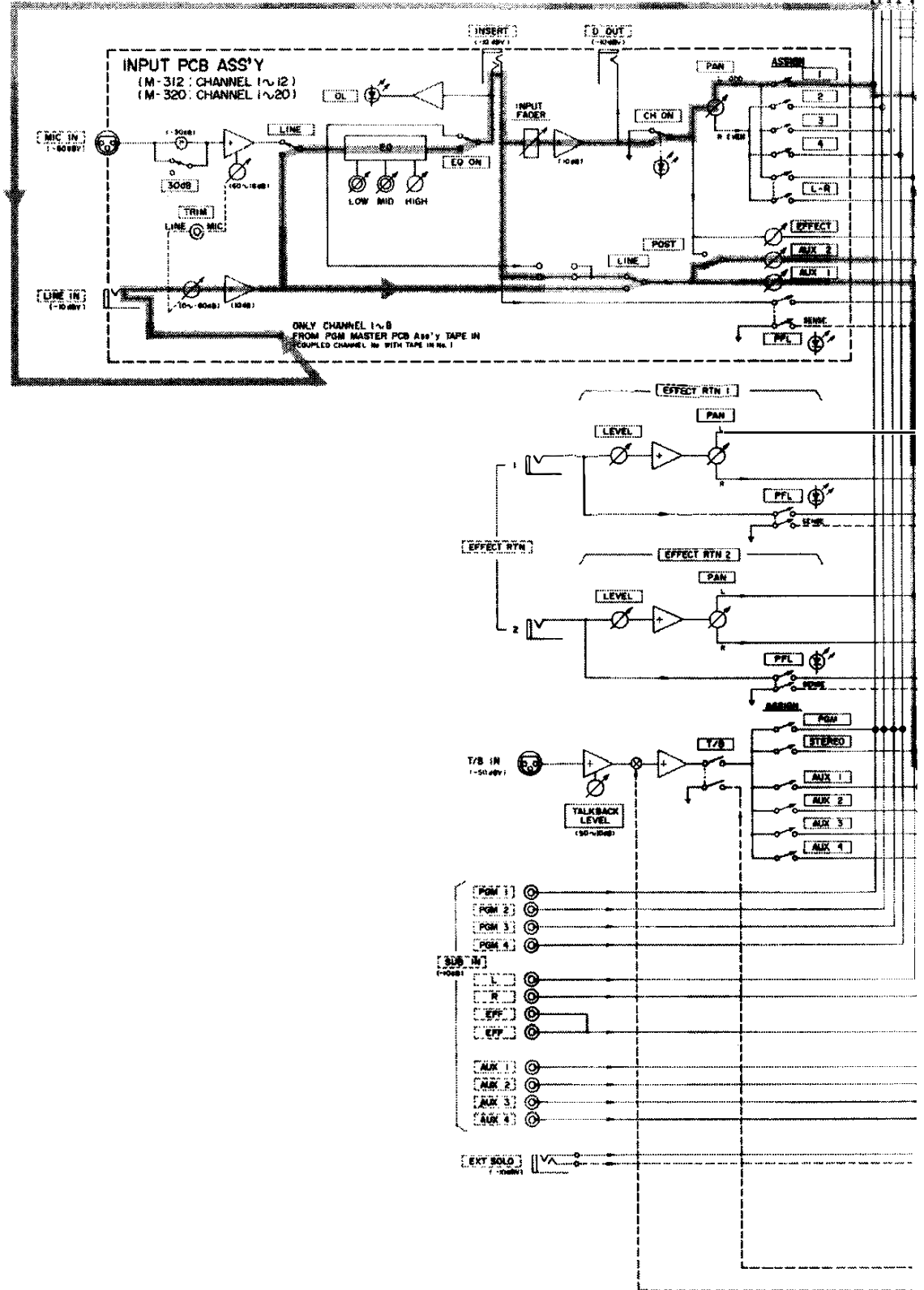

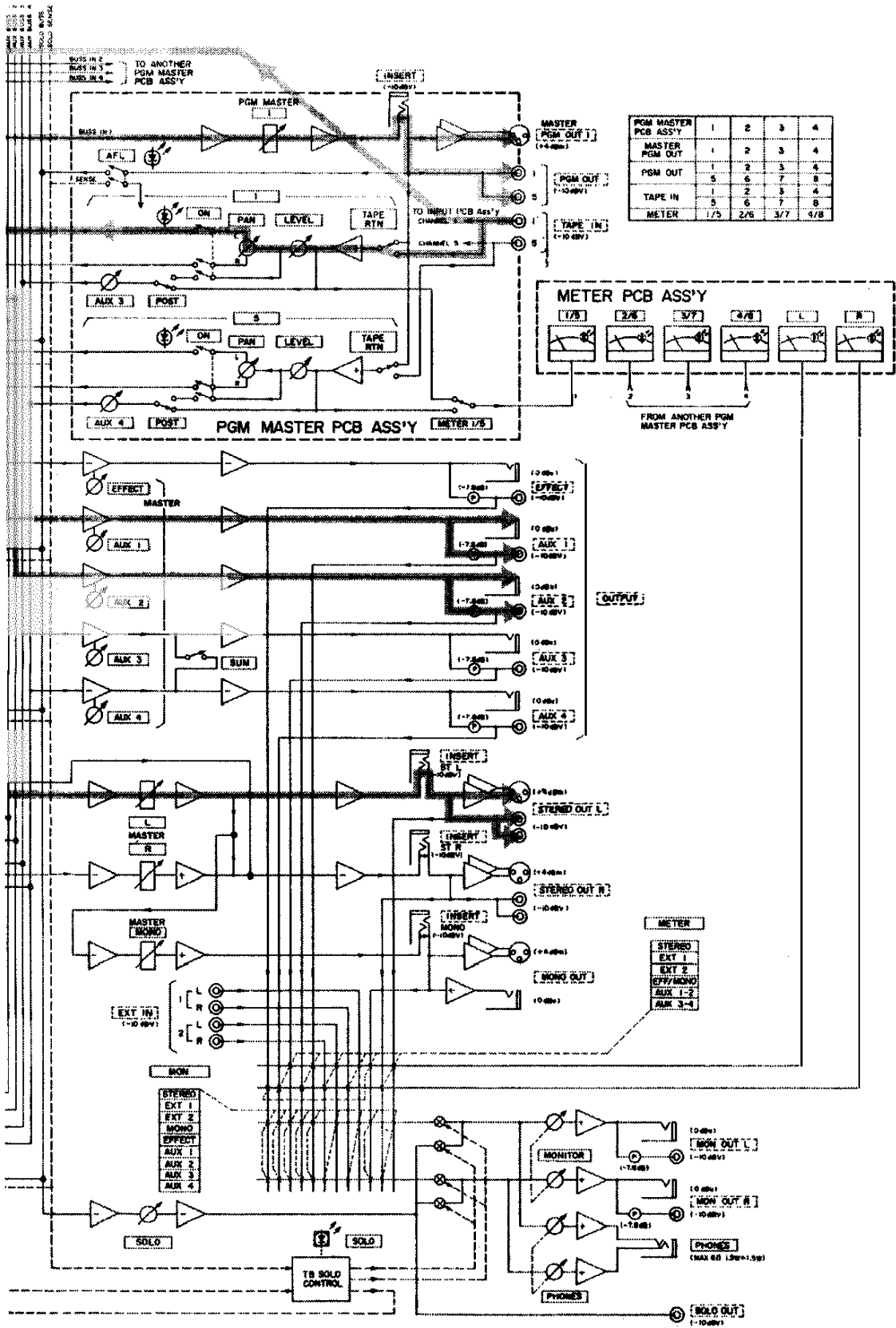

OPERATIONAL NOTES AND APPLICATIONS

This section of the manual is designed to assist you in initially connecting and using your 300 Series Mixer. We provide several examples to aid you, but these guidelines should not be considered as the "only" way to perform the task at hand. As you learn the various sub-systems of the 300, you will discover alternative work methods which may suit your particular mixing situation more appropriately.

BASIC SOUND REINFORCEMENT

The 300 Series was designed specifically to address the needs of the audio professional whose demands may include live sound reinforcement as well as recording. Each model in the series is capable of handling equal numbers of MIC and LINE level inputs, plus additional signals processed through the EFFECTS, TAPE RETURNS and various buss SUB INPUTS.

In our first example, we show a simple yet very common mixing situation using four (4) mics and four (4) line level signals. As you can see by our system diagram, the 308 is being used to mix a live performance of a musical group consisting of an acoustic guitar, an electric guitar, a bass guitar and two different keyboard instruments: a stereo synthesizer and an electric piano. Three of the performers have vocal microphones, with one of them performing most of the lead vocals. Additionally, since the group does not have a drummer, an electric rhythm unit is used. In our example, we show a model M-308, but a M-312 or M-320 could also be used in a similar manner.

Basic Connections

The mics are connected to input channels 1-4 while the line level signals are added through channels 5-8. The rhythm unit is connected to the PGM 3 SUB IN jack, although on the larger models of the 300 Series it could be mixed through another input channel. We will detail other ways of mixing additional signals several places in this manual. Since the 300 Series is a four buss design, the signals can be sub-mixed or grouped prior to the stereo or mono mixing stage. This method of signal grouping allows the operating engineer to concentrate on mixing a small number of groups rather than all the input channels. This reduces the complexity of the mix and chances of error. In our example, the

background vocal mics are grouped together in PGM 4; the keyboards are in PGM's 1 and 2; the bass is in PGM 3, summed together with the electronic rhythm unit. The acoustic guitar and lead vocal mics are routed directly to the LEFT and RIGHT STEREO MASTERS. The final stereo signal is mixed through the PGM group monitor sections to the LEFT and RIGHT STEREO MASTERS. This signal then feeds the main power amplifier and house speaker system.

On-stage monitoring is controlled by the AUX 1 sends which are in the "pre" position. This allows the monitor signal to operate independently from the main or house signal. The stage monitor amplification system is connected to the AUX 1 output.

Special audio effects devices such as reverb, echo, compression, etc., can be patched into the signal path at four different points:

1. through the individual channel INSERTion jacks, for processing a single signal,
2. through the PGM INSERTion (1-4) jacks, for continuous processing of a selective mix or group of signals,
3. through the EFF OUTPUT and TAPE IN RETURN jacks, for top panel control of both level and distribution over a selective, individually adjustable, group of signals, or,
4. through the STEREO L & R or MONO INSERTion jacks, for continuous processing of the final mix of signals.

Once the basic system configuration has been determined, it's time to physically wire the various components together — the house and monitor speakers, amplifiers, microphones, etc. When installing this or any audio system, make sure the signal processing devices are turned off and all the level controls are turned down.

Once all the connections are made and double checked, begin energizing the system by first turning on the mixer, then any active effects devices, and finally, the power amps.

Note: When shutting a sound system down, ALWAYS turn the power amps off FIRST. Wait at least for 30 seconds for

SOUND REINFORCEMENT

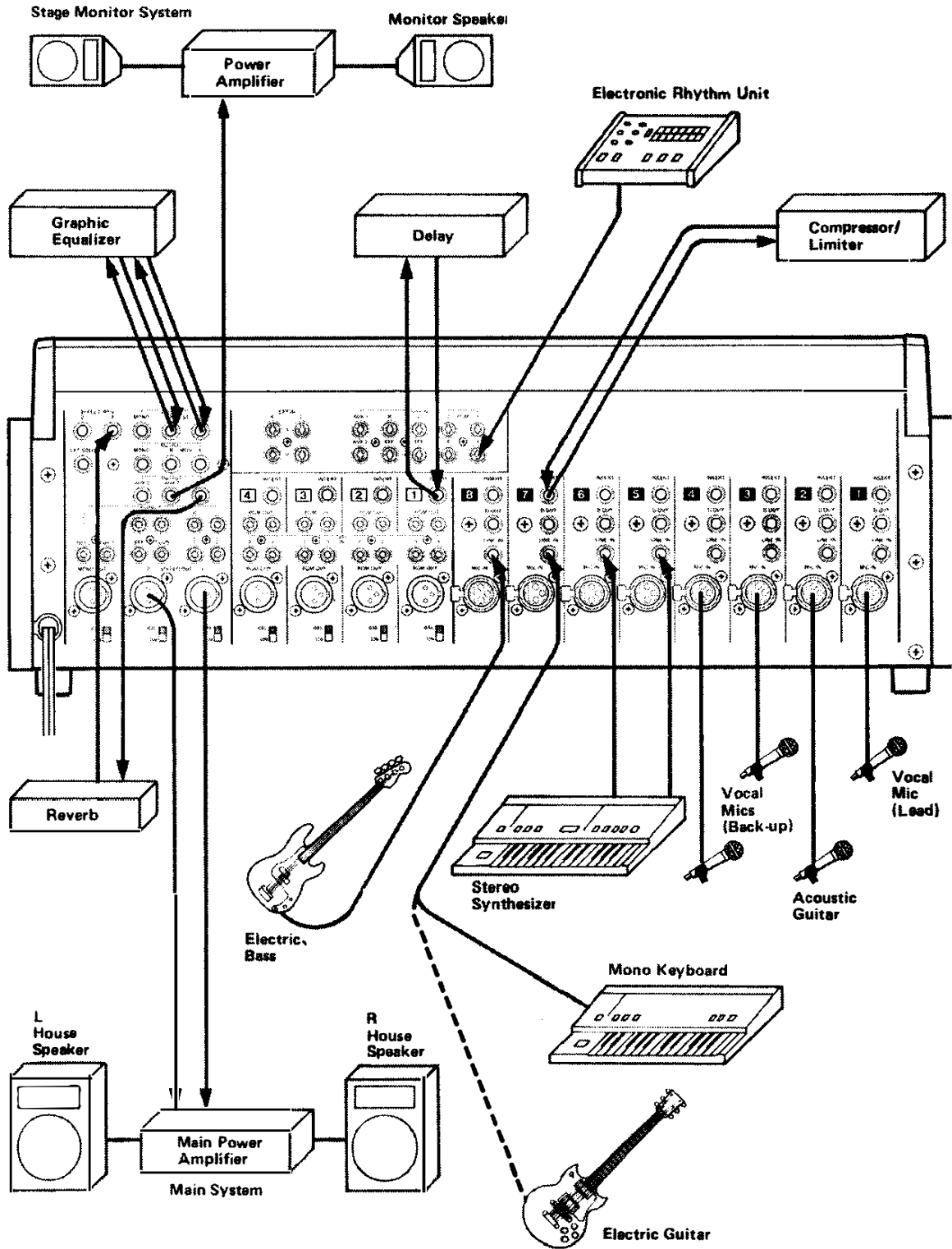

SOUND REINFORCEMENT

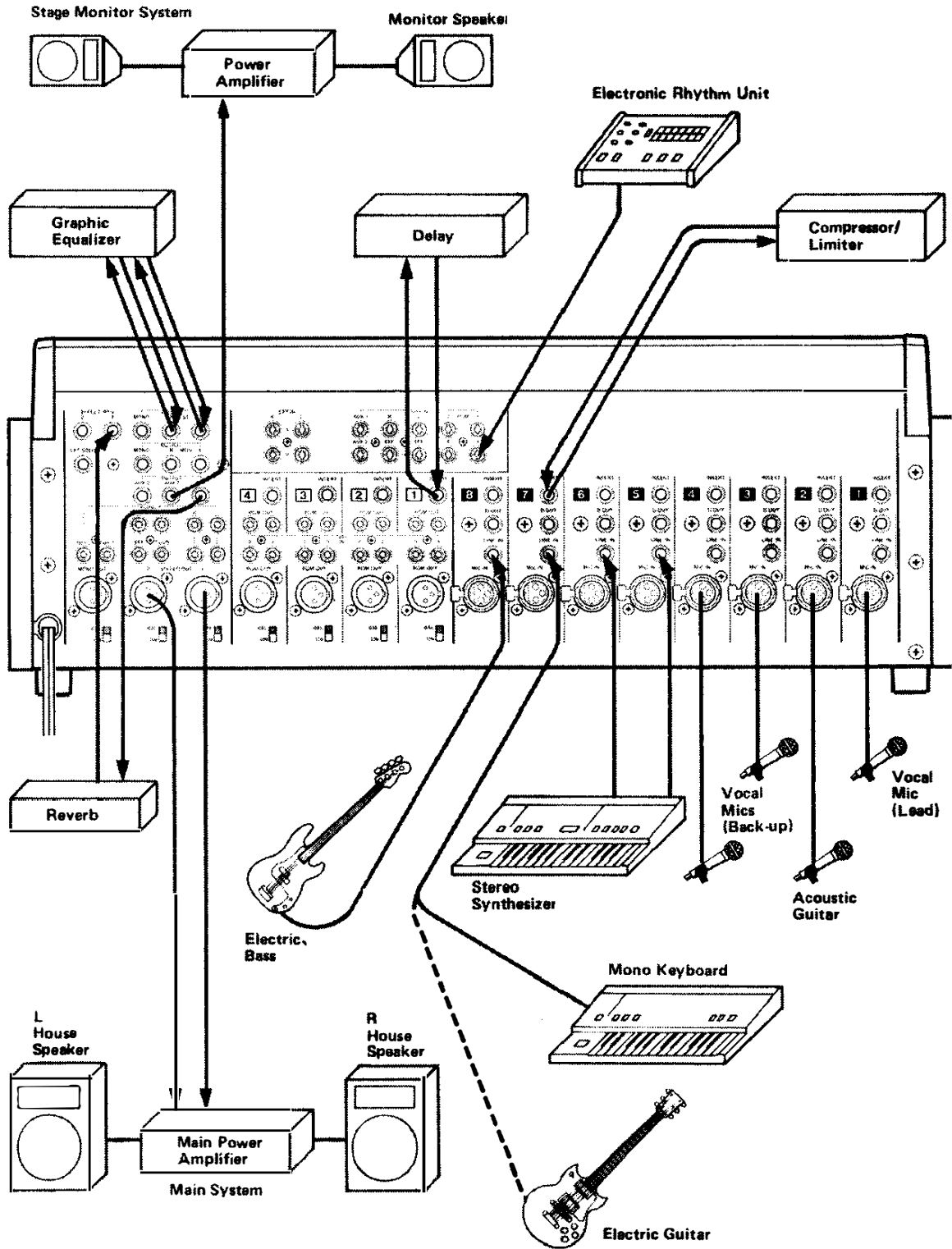

capacitors to discharge, then continue to turn off the remaining equipment. Turn the mixer off last.

When the system is operational, begin making the initial control settings. We suggest starting with all the EQ controls set at 12 o'clock and the AUX send controls off (fully counter-clockwise). Set the channel input select switches (LINE) to the appropriate position; MIC (up) or LINE (down). Assign the channels to the desired groups using the assignment switches and PAN controls. Remember, even if a channel is assigned to only one PGM group, the PAN control will still affect the signal. Thus the PAN should be turned all the way to the left or right if only one PGM group is selected.

Begin setting the input gain levels, starting with the first channel, by turning the MIC or LINE gain TRIM control to the 12 o'clock position. If the channel is assigned to a PGM group, raise the corresponding PGM FADER to the 7-8 position. If the channel is assigned to the LEFT and RIGHT STEREO MASTERS, raise those FADERS to the 7-8 position. These settings approximate the unity gain position of the PGM and STEREO MASTER section amplifiers and allow relatively accurate VU meter readings. Remember, this procedure is the initial gain setting step. In the actual rehearsal prior to the performance, minor adjustments are usually made to "fine tune" the various control settings.

If the channel is processing a MIC signal, have someone speak into the MIC. Engage the channel "ON" switch and slowly raise the FADER. The level will be correct if the assigned PGM or MASTER VU meter reads near or at 0 and the channel FADER is set between 7-8, the shaded area on the fader scale. If the fader is below this range, reduce the gain trim slightly and raise the fader to the desired position. If the fader is above 8, lower the fader to the proper range, then slowly increase the gain trim until the VU reading is correct (at or near 0).

If the MIC signal level is too high or strong, the channel OL (overload) LED will fire. If this indicator is on constantly, turn the MIC TRIM control down. If this fails to correct the overload condition, press the PAD switch. This inserts a 30 dB pad into the mic circuit prior

to the first stage of gain, thus reducing the possibility of overloading and distortion. If the OL LED only flashes periodically, but the channel fader is at a low position (below 6), adjust the MIC TRIM control down until the fader can be raised to the proper level. These procedures are designed to provide you with the proper amount of gain, the lowest noise and the most headroom possible.

Line level signals such as those generated by a synthesizer, as in our example, may be set in a similar fashion as the MICS. Merely select LINE as the source and adjust the LINE TRIM control and fader for the desired level. Unlike MIC signals, instruments which generate line levels usually provide an output level control. This external control must be properly adjusted to prevent overload of the LINE INPUT.

When all the various channel levels have been set, and the channels assigned, the final PGM and STEREO levels can be determined. In our example, we have assigned several signals to the four PGM GROUPS and others directly to the LEFT and RIGHT STEREO MASTERS. The obvious questions arising from these actions are: Why use the PGM GROUPS? and, How is a PGM GROUP signal mixed to the STEREO MASTERS?

First, let's look at the assignments. We've assigned different instruments or voices which perform similar musical tasks to the same groups. As an example, the two background vocal mics are assigned to PGM 1. This allows the operator to control the final level of both mics with only one fader. In other instances, such as the lead or main vocal mic, the signal is sent directly to the STEREO MASTERS, bypassing the PGM GROUPS. This allows the signal to be varied in the final mix without disturbing any other signal. This method of mixing reduces the complexity of the mix while still allowing full creative control.

Adding the PGM GROUP signals to the STEREO mix is relatively simple. Above each GROUP FADER there are two identical, yet separate, MONITOR sections. Each section is numbered, 1-8, and contains an input select switch (TAPE RTN), a LEVEL control, a PAN control, and an ON switch. On the M-312 and M-320 models, there is an additional control not found on the

M-308. This is an AUX send control, similar to those found on the input channels. On MONITOR sections 1-4, this control is identified as AUX 3, while those found on MONITORS 5-8 are labeled AUX 4. Each PGM GROUP has one of each MONITOR set in its domain: PGM 1 carries 1 & 5, PGM 2 has 2 & 6, PGM 3 has 3 & 7, and PGM 4 has 4 & 8. Each MONITOR section can be independently assigned to receive its input from one of two sources: the corresponding TAPE IN jack, or the PGM buss in which it physically resides. The MONITOR LEVEL and PAN controls determine the overall strength and distribution of the signal to the STEREO MASTER busses. The ON switch provides the means to mute the MONITOR; thus, any signal can be isolated from the final mix if desired. Since each PGM GROUP has two MONITOR sections, each buss can be mixed by *one* while the *other* can be used as an additional LINE input or EFFECTS RETURN. As we will show further on in this manual, the double MONITOR mix system, while redundant for some applications considerable expands the flexibility of the 300 Series for sound reinforcement.

Adding More Input Signals

In our example, we are adding the synthesized rhythm signal to the PGM 3 buss SUB IN jack. As we've just seen, we could also add this signal through any of the 8 MONITOR sections by simply connecting the signal to one of the TAPE INs. When using the method shown, best results will occur when the external device generating the signal has an output level control, because the SUB IN jacks have no provision for controlling the incoming level. If on-board control of the external signals is necessary, there are several other methods which can be used.

1. Signals can be added through the EFFECTS RETURN sections. Each of the two networks is identical but independent and consists of a LEVEL and a PAN control. The signal can be controlled, balanced, then added to the LEFT and RIGHT STEREO busses. This allows the signal to be controlled independently from the PGM GROUPS.

2. On all 300 Series mixers, the AUX 1 and AUX 2 channel send controls are assignable either to the channel signal path or directly to the LINE INPUT. If a given channel is used to

process a MIC signal, a separate LINE signal can be connected to that channel's LINE INPUT and routed to either AUX 1 or AUX 1 & 2 by pressing the AUX LINE switch and de-selecting the AUX POST switch. The external signal is now controlled by the selected channel AUX send and MASTER controls and is available at the AUX 1 or AUX 1 & 2 outputs. This can then be patched back into the mixer through the appropriate SUB IN jack for inclusion into the final STEREO mix.

3. Extra signals can also be added using the eight (8) TAPE IN jacks. As explained previously, these provide signal to the corresponding MONITOR sections, which, in turn, can mix the signal into the final STEREO mix. Some thought and caution must be used when applying this approach, as the MONITORS are also used to mix the PGM GROUP signals to the STEREO masters. When using the PGM GROUPS in a mix and using the TAPE RETURNS for adding signals, always make sure each PGM GROUP has at least one MONITOR section assignable to the PGM. This means that if all four PGM GROUPS are in use during the mix, only four external signals can be added through the remaining unused MONITOR sections.

These extra systems add flexibility to the 300 Series. Each model, therefore, becomes more than 8, 12 or 20 input, 4 buss, stereo and mono output mixer. For example, the smallest version, the M-308, can mix up to 8 MIC and 8 LINE signals simultaneously, and, if these signals are sent directly to the STEREO MASTERS, 8 additional line level signals can be added through the TAPE IN jacks. By merely patching the AUX 1 & 2 outputs back into the EFFECT RTN jacks, 24 different signals could be easily mixed and controlled, creating a final stereo and/or mono output signal. The models M-312 and M-320, with their additional input channels and AUX sends, can easily mix more than twice their number of channel signals. See chart on Page 11.

Setting Auxiliary and Effects Send Levels

When using the additional subsystems found on the 300 Series mixers, setting the signal levels is equally important as the channels levels. The procedure is very similar; however different controls come into use. In our example, we need to use AUX 1 for an on-stage monitor

feed. Since most stage monitor signals are derived "pre-fader", AUX 1 will provide this signal when both AUX select switches are in the up position. Begin by setting the channel AUX 1 control of each desired channel to the 12 o'clock position. Next, press the AUX 1/2 switch in the METER SELECT SWITCH RACK. With signal present in a channel, raise the AUX 1 MASTER control until the Left VU meter reads about the same as the PGM meter. Set each selected channel AUX 1 control for about the same level. Once all the desired channels are set, adjust the overall mix. This can be done using the HEADPHONE MONITOR section, selecting AUX 1 and listening through a pair of headphones while making the necessary changes to the various AUX 1 controls.

When setting stage monitor levels, several precautions should be taken. If feedback (howling) occurs, reduce the AUX 1 MASTER control and reposition either the monitor speakers or the mics. These actions should allow the level to be raised to the desired point. Often, several various combinations of speaker and mic positions must be tried before the most useable combination is found. Keep in mind that monitor output levels generally do not need as high as the program level. The object of on-stage monitoring is to allow the performers to improve their individual sound and timing.

Setting the EFFECTS SEND and RETURN levels is similar to the preceding procedure. There are, however, several important differences:

1. Setting the output and return levels is more a matter of (*taste*).
2. Setting and balancing the out-going signal to the effect device is required, mixing and balancing the returning or "wet" signal with the existing or "dry" signal within the console.

In the diagram shown on page 32, our example shows a typical reverb unit patched from the EFF OUTPUT and back into the EFFECT RTN 1. Using a single mic input, set the channel EFFECT send control to about 12 o'clock. Next, press the EFFECT/MONO switch on the METER SWITCH RACK. Watching the STEREO LEFT VU meter, raise the EFFECT MASTER control until the meter reads about -10. At this point, our instructions must move from the science of mixing audio to the art of technique. Setting

the return level can be done by either headphone monitoring or by listening to the signal through the house speaker system. The on-board controls used are the EFFECT RETURN 1 LEVEL and PAN. The LEVEL determines the ratio of returning (wet) signals to the existing (dry) signals. The PAN sets the left-to-right balance of the wet signal. As we can only illustrate a typical example of this type of application, we can only tell you which controls perform pertinent functions. Since many external signal processing devices contain their own input and output controls, achieving the desired effect becomes a matter of adjusting the EFFECTS output level (both channel and MASTER), the device's controls, and the EFFECTS RETURN LEVEL and PAN controls.

If, during the mixing process, you need to visually monitor the wet signal, de-select the specific channels' buss assignment switches. This leaves *only* the returning signal in the STEREO MASTER busses. These can be metered by pressing the STEREO switch in the METER SWITCH RACK.

Setting the Final Output Level

The preceding sections have covered the various input and intermediate stages available for mixing audio on the 300 Series. Our examples and recommendations are designed to provide the lowest possible noise with the highest possible headroom. Obviously, the considerations of the program content, artists, and audience will require some variations from these instructions. For this reason, we intentionally excluded subjective areas such as EQ settings. For more information on the use of EQ see page 44. The setting of the final output level is a similar consideration. While the final level is determined by the STEREO MASTER FADERS or, if a single output is desired, the MONO MASTER FADER, it would be presumptuous for us to suggest the "best" level setting. Ideally, the STEREO VU meters should read below or the same as the PROGRAM meters, but this is an ideal and cannot be offered as an absolute. The actual final setting for a live performance can only be judged and set by the operator.

BASIC RECORDING PROCEDURE

In the preceding section on Live Sound Reinforcement, we went into some detail regarding the proper set-up and usage/procedures of the various submix systems. When using the 300 Series for mixing audio for multitrack recording, these same systems and procedures can be used, although not necessarily for the same purposes or reasons. While sound reinforcement mixing requires two mixes (house & stage monitor), recording is divided into THREE separate mixing tasks.

1. We must route the input signals to the desired tracks of the recorder at the proper level to achieve the best signal-to-noise ratio. This is NOT always consistent with the best *sounding* mix.
2. We need one or more CUE mixes for the artists.
3. We must create a MONITOR MIX in the control room for the engineer and/or producer.

To be most effective, these three (3) mixes must be independent of each other.

We will not repeat the basics of setting levels, routing AUX signals, using effects, etc. Here we will describe the techniques primarily applicable to recording.

Basic Connections

In our examples for recording, we will assume you are using a four track recorder. When we discuss the basic mixdown procedure, we will assume you will use a standard two track recorder. Later in this section, we will discuss using the 300 Series in conjunction with an eight track multitrack recorder.

The first step is to connect the four track to the mixer. Since the 300 Series has 4 PGM OUTputs, the simplest method is to connect PGM OUT 1 to track 1 input of the recorder, PGM OUT 2 to the track 2 input, etc.

Next, connect the four track outputs of the recorder to the TAPE IN jacks 1-4 found on the rear of the 300 Series. Again, the simplest way is to connect the corresponding numbers; track 1 to TAPE IN 1, and so on. Once these connections are complete, you can proceed to calibrate your system (see page 42).

Since both the recording engineer and the in-studio performers will need to hear the mix, our example shows both a CONTROL ROOM monitor system and a STUDIO monitor system.

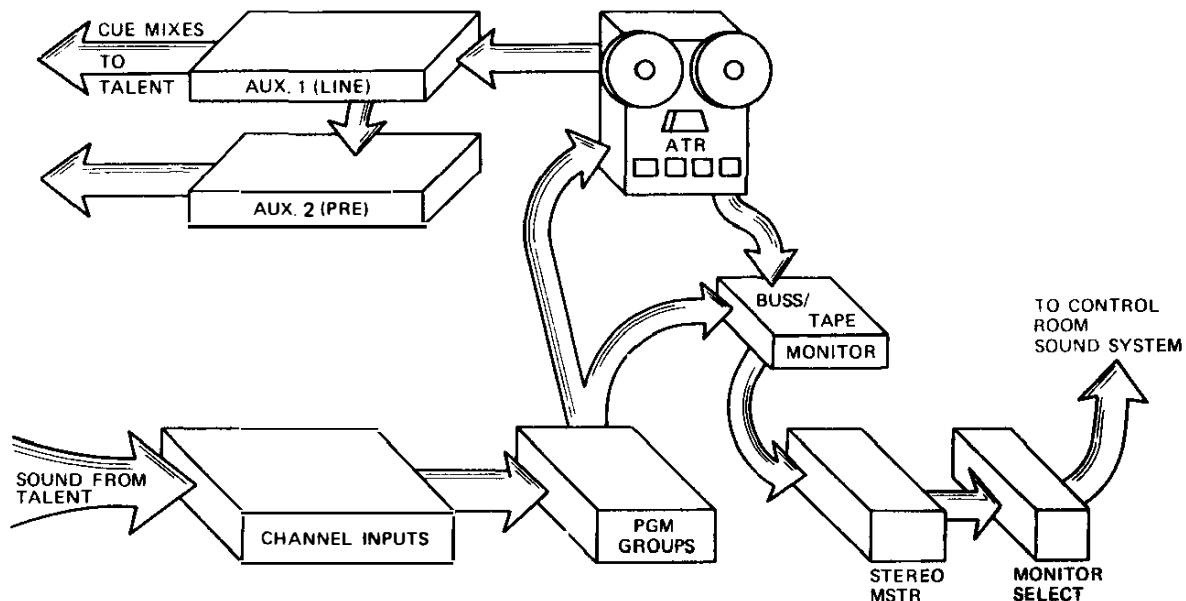

STUDIO RECORDING

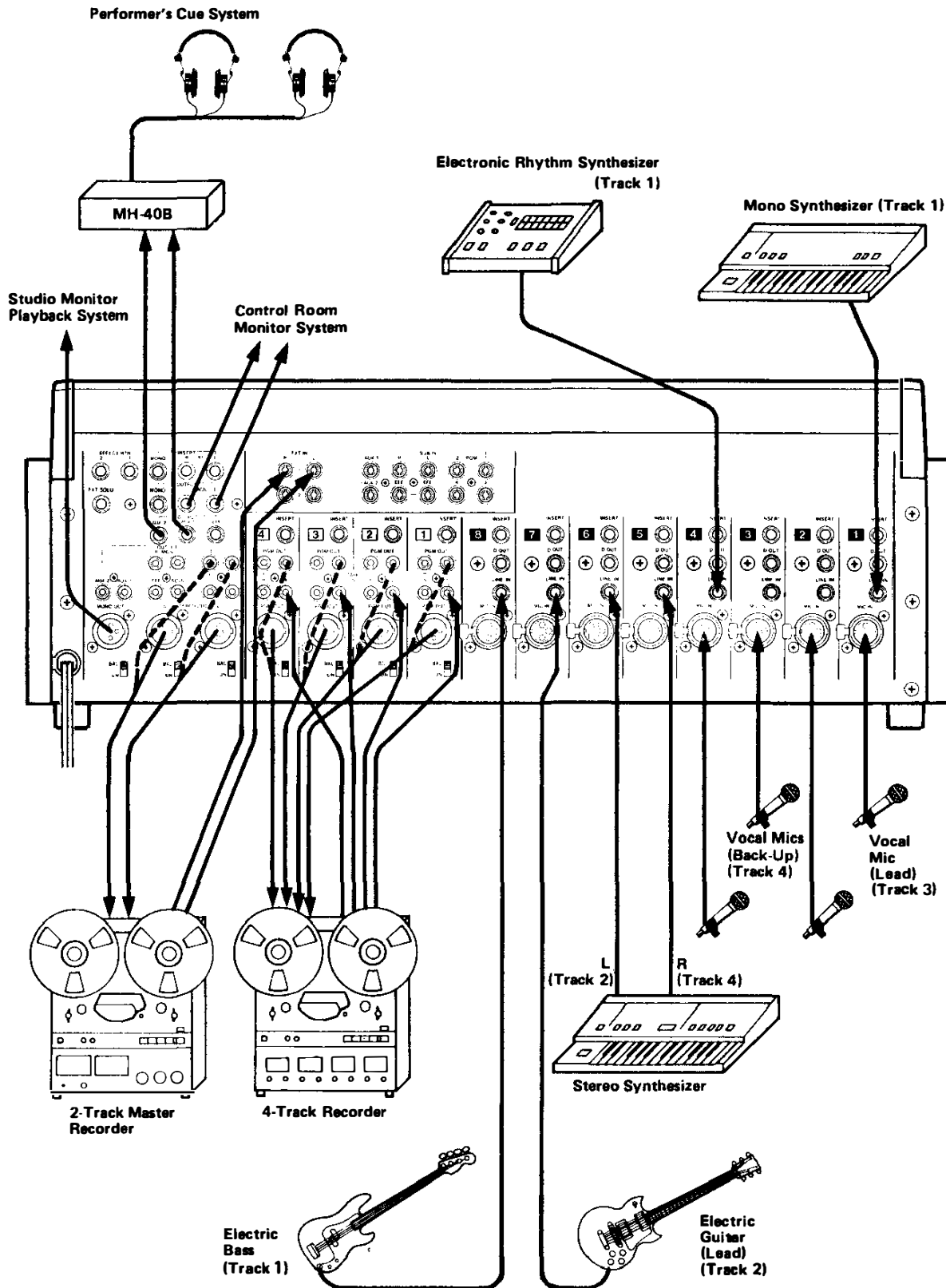

Also shown is the performers' CUE system which provides selective signals to headphones. In our example we use a TASCAM MH-40B Headphone Amplifier.

The CONTROL ROOM system is driven from MONitor OUTPUT system. The signals available are switchable, using the MONITOR SWITCH RACK, allowing the engineer to make critical evaluation of the various mixes. Additionally, the SOLO system automatically switches any signal selected to the SOLO buss to appear at the MONitor OUTPUTs.

The STUDIO system is connected to the MONO OUTPUT jack. This allows the engineer to play back various mixes or other sources for the rehearsal usage by the in-studio talent. Once actual recording commences, this output is closed to eliminate track bleed through and the performers can hear only through their headphones. Since the CUE system is driven from the AUX sends, the composition of the signal can be quickly changed and controlled, depending on the needs of the performers.

Recording the Basic Tracks

Remember, in the live session we needed to mix all the signals simultaneously, ultimately achieving a stereo left and right signal pair. Here, we will use the four PGM busses, but we don't have to mix and record all the signals at one time. By building the multitrack master tape in layers, one track at a time, we can actually record more information overall than if we recorded all four at once.

The first track to be recorded is the basic rhythm track, consisting of the electronic rhythm synthesizer (LINE IN, Channel 4), mono synthesizer (LINE IN, Channel 1), and the bass (LINE IN, Channel B). Assign channels 1, 4, 8 to PGM buss 1 (Track 1). Set the PAN control all the way to the left. Using the techniques described in the preceding section, set and balance the signal levels.

Now we can begin to set up the studio cue feed so the performers can hear each other and play in time with the other instruments. The cue mix is created in the same way the stage monitor mix was done in the previous section. Since, in this mix, only the bass and synth players need to hear the rhythm signal, use the AUX 1 send on

the electronic rhythm input channel. This feeds the headphone amp used in the previously detailed cue system. To create your control room monitor mix which will probably be different from the cue mix, simply press the TAPE RTN switch on MONITOR section 1, set the LEVEL and PAN controls and the STEREO L and R FADERS. Select STEREO on MONITOR SWITCH RACK and set LEVEL CONTROL for a comfortable listening level.

This allows you to:

1. Hear the signal as it's actually being recorded, and
2. Verify the signal continuity to and from the mixing console and the recorder.

Once these steps are complete, you can record the track. When the recording is complete, rewind the tape and play it back through the control room speaker system. You don't have to change any control settings to do this! You should hear exactly the same mix as while you were recording. If playback is also desired on the STUDIO speaker system, raise the MONO MASTER FADER. When finished, remember to lower the MONO MASTER FADER. Once you are satisfied with first track, you can continue to build the tape one track at a time. This technique is known as overdubbing. Overdubbing is the process of adding new material to one track of tape, in time with a previously recorded track. Again for example, track 2 could be the lead guitar and the left hand side of the stereo synthesizer, track 3 the lead vocals, and track 4 could contain the right side STEREO section and the background vocals. Keep in mind, as each track is recorded, the previous tracks can be sent to the cue system for reference by selecting the LINE input to AUX 1 of the appropriate channels.

After every pass, play back the newly recorded material, first alone, then together with the previous tracks. This will allow you to hear if any audio or acoustical problems are emerging, such as improper tuning, voicing timing errors, etc. If problems are found, correct the cause and re-record the track. While certain tonal characteristics can be equalized and adjusted later, many problems are impossible to "fix in the mix".

Eight Track Recording

Before we discuss the mixdown procedure, this is an appropriate place to discuss another aspect of the 300 Series' flexibility. By this time, you should be familiar with the eight (8) outputs labelled PGM OUT and eight (8) inputs labelled TAPE IN 1-8. This would indicate that the 300 Series can perform eight track recording and mixdown, which, indeed, they can. Since the 300 Series is a four buss design, each buss supplies signal to a pair of PGM RCA type outputs. Each pair is controlled by a single PGM fader and the signal is identical at either jack. The pairs are grouped as follows: PGM 1, outputs 1 and 5, PGM 2, outputs 2 and 6, PGM 3, outputs 3 and 7, and PGM 4, outputs 4 and 8. By connecting an 8 track recorder in place of the 4 track deck as we have described, the track building process could be continued until all 8 tracks are recorded.

Mixdown Procedure

Once the multitrack master tape has been completed, the next step is to mix it down to a standard two track stereo format. The procedure is similar to the recording process; however there is usually no need for the studio musicians to be present unless overdubbing is going to occur. The only additional equipment required is a two track mastering recorder and any auxiliary effects devices you feel may be needed.

The basic hookup is straightforward: the STEREO LEFT and RIGHT OUTPUTS are connected to the inputs of the 2 track while the machine's output are connected to the EXTERNAL 1 Stereo L and R INPUT jacks. Any effects devices required can be patched through the various access points described on page 31. In addition to these patch points, a fifth method is possible. This technique is trickier but is handy if the returning signal is subject to level variations or requires equalization. The input of the effects device can be driven from any appropriate access point or output. The output of the device can then be connected to the LINE INPUT of any unused channel. The returning signal can then be routed and controlled as if it were a normal input signal. Caution must be exercised to prevent the returning signal from being mixed with the original outgoing signal, or a feedback loop will be created. This will cause a loud, howling sound and could cause damage to your equipment.

Since the multitrack machine's outputs are connected to the TAPE INs, the mixdown can be done entirely in the MONITOR and STEREO MASTER sections. Simply calibrate the equipment, select the desired tape returns, set the tape return level and pan controls, set the final stereo levels, rehearse or preview the mixdown, and roll tape.

If you need to re-equalize a track, or use external effects, no re-patching is required. For example, let's say track 1, our basic rhythm track, needs more low frequency power or "punch". Simply de-select the TAPE RTN switch on MONITOR section 1. Make sure no connector is plugged into channel 1's LINE INPUT jack, then press the LINE switch on channel 1. This automatically routes the track 1 return to input channel 1. By assigning the channel directly to the LEFT and RIGHT STEREO busses, the remixed signal can be re-introduced to the remainder of the signals.

As with any recording session, once the mixdown is completed, review the results before you repatch or put the equipment away. If the results indicate the need to make changes, go back and do it again.

VIDEO PRODUCTION, POST PRODUCTION, AND AUDIO SWEETENING

Mixing audio for video has become a demanding field, due to the rising sophistication of both the production facilities and the viewing audience. With the proliferation of cable T.V. systems offering stereo audio feeds as well as the coming stereo and multichannel T.V. sound (MTS) systems for over the air programming, the awareness of the importance of quality audio will continue to grow. Another rapidly emerging area of importance is non-broadcast video. As corporate and industrial telecommunications expand, the need for improved audio quality will keep pace. The TASCAM 300 Series has all the features necessary to fulfill the audio control needs of the small to medium production house or off line editing/sweetening facility. Virtually all popular brands and models of 1/2" and 3/4" VCR's and 1" VTR's will interface directly with the 300's.

Typically, MONO or STEREO audio signals from a variety of sources can be mixed simultaneously. These signals could originate from studio feeds, VCR's, VTR's, voice-over (v.o.) mics, turntables, audio cassette or cart machines, or any other mic or line level source. The mixed signals can then be assigned to the master video cassette editing recorder. Since the 300 Series features four PGM outputs in addition to the stereo outputs, multiple master copies of the audio program may be recorded. These additional signals may be remixed as clean feeds, without the normal narration and voice-over mix. These mix-minus masters can be used for later dubbing in a second language.

The AUX sends may be used to generate cue feeds to the v.o. announcer or for connection to the studio IFB (Interruption Foldback) or P.L. (Private Line) systems. The EFFECTS SEND and RETURN sections can be used for side chains of special audio effects. In the example shown, two source VTR's are shown in a typical A-B roll editing situation. Two v.o. mics are also connected as well as two additional audio sources: a cassette and a cart machine. These latter two pieces can be used to add mono or stereo sound effects or wild track ambience to the final mix. These machines could also be used to roll effects into the mix live or "on the fly".

Monitoring of the various mix components and the final mix is handled through the 300's comprehensive MONITOR section and outputs, while the v.o. cues are taken from the AUX 1 send.

The edit MASTER RECORDER receives signals from the STEREO OUTputs while a clean international dub (mix-minus narration and v.o.) is being recorded from PGM OUTputs.

VIDEO PRODUCTION

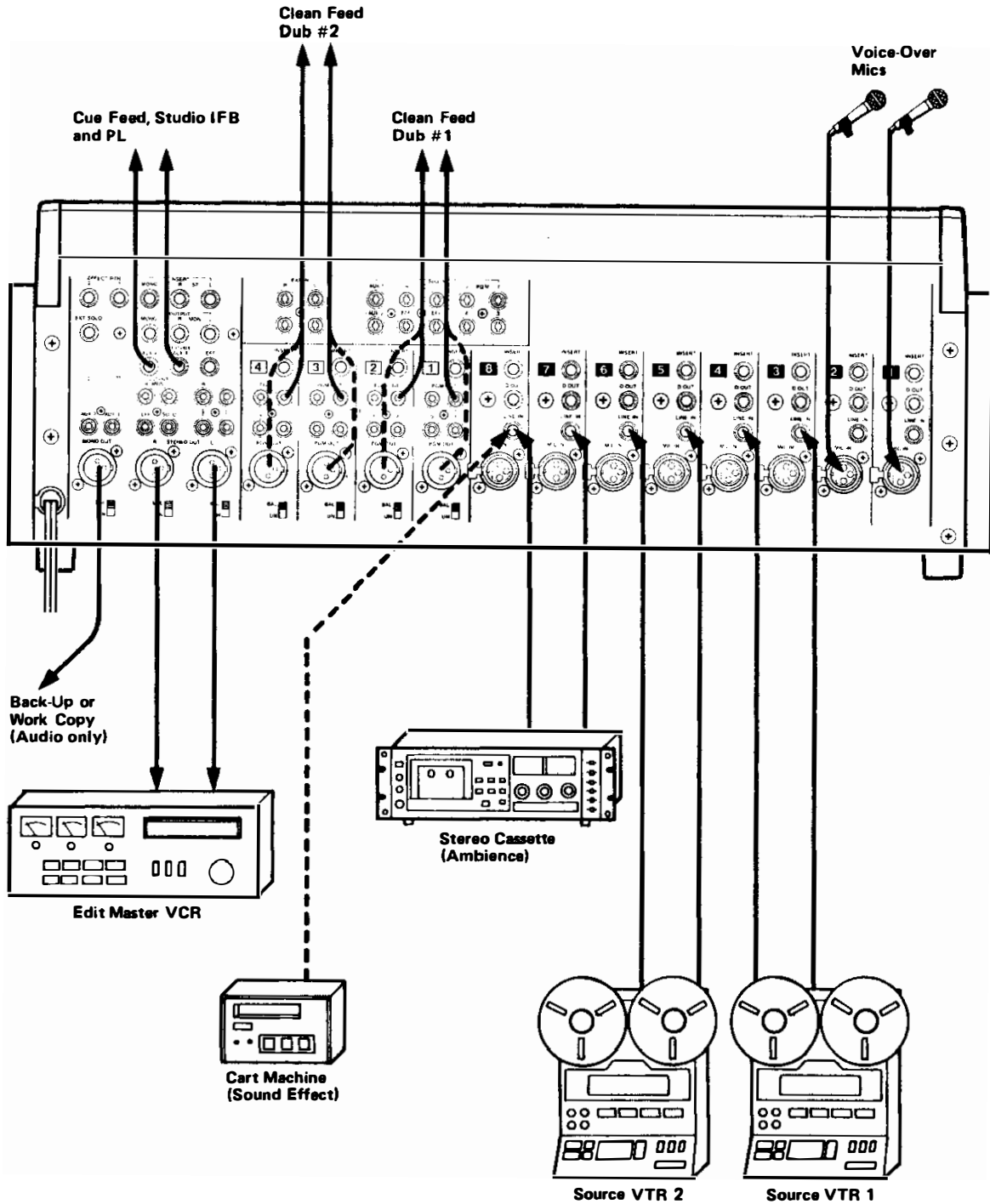

CALIBRATING THE 300 SERIES MIXERS FOR RECORDING

Calibrating the 300 Mixers is simply the process of matching the consoles' outputs to the rest of the equipment being used. In this example, we will assume you are using a 4 track recorder. The method we describe here can be used with virtually any type of equipment you are likely to encounter.

1. The first step is to connect the appropriate PGM 1-4 OUTs from the 300 Mixer to the inputs of the recorder. Remember, the 300 Series have three different output configurations: unbalanced, referenced to -10 dBV, using RCA-type phono jacks; balanced, referenced to +4 dBm, using XLR-type connectors; and unbalanced, referenced to +4 dBm, using XLR-type connectors. Make sure you choose and connect the proper signal level for the equipment being interfaced.

2. Next, you need to apply a signal to the system. A test tone generator or test tape is handy to have for this procedure. Assuming you are using a tone generator, set the frequency to 1 kHz and connect the signal to the channel B MIC or LINE INput, whichever is appropriate.

3. Select the proper input for channel B. Turn the EQ section off and turn the channel on.

4. Assign channel 8 to PGM's 1-4 and set the PAN control to the 12 o'clock (center) position.

5. Raise all four PGM faders to the shaded area, about 7-8 on the gradient scale.

6. Make sure the TAPE RTN switches on MONITOR sections 1-4 are in the UP position (TAPE RETURNS de-selected), make sure the four METER select switches are in the UP position.

7. Set the proper input TRIM control on channel 8 to 12 o'clock.

8. Raise the channel 8 FADER until the VU meters read 0. The channel FADER should be in the shaded area. If it isn't, adjust the TRIM control until it is correct.

9. When all four output meters read 0 VU, raise the input level controls until the recorder's meters all read 0 VU.

10. Record the 1 kHz tone with the level set at 0 VU for about a minute.

11. Connect the outputs from the recorder to TAPE IN jacks 1-4 on the 300 Mixer.

12. Press the TAPE RTN switches on MONITOR sections 1-4.

13. Rewind the tape to the beginning of the recorded tone.

14. Play the tape. The four PGM meters on the 300 Mixer should read 0 VU. This allows you to verify the accuracy of the preceding steps. Since you will also need to calibrate your system when remixing down to a stereo master tape, we will describe this process as well.

Continuing with the steps detailed above, proceed as follows:

15. Set the LEVEL and PAN controls on MONITOR sections 1-4 to 12 o'clock position.

16. Raise the STEREO LEFT and RIGHT MASTER FADERS to the shaded area, about 7-8 on the fader scale.

17. Press STEREO on the METER SELECT SWITCH RACK.

18. Repeat steps 14 and 15 (above). Since we've already verified the returning levels, here we are focusing only on the readings of the STEREO VU meters.

19. The STEREO METERS should read 0 VU. If the readings are too low, adjust the four MONITOR LEVEL controls slightly higher. If the meters are too high, adjust the levels downward slightly. A handy tip for making this adjustment faster and simpler: turn two of the MONITOR PAN controls fully left and the other two fully right, then make the necessary level adjustments. When all four PANS are returned to the center position, the meter readings should remain at 0.

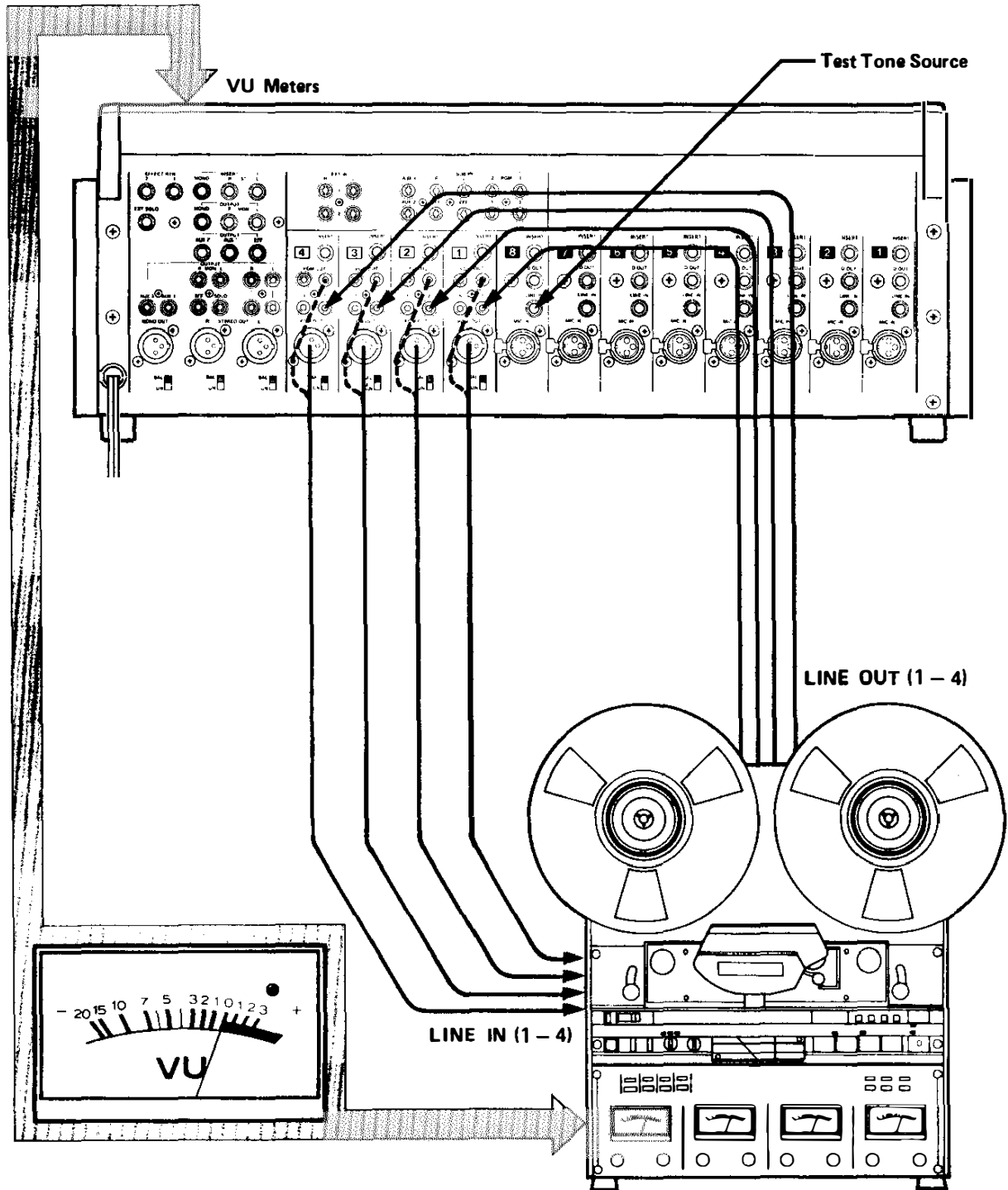

HOW TO USE THE EQUALIZER (EQ) SECTION ON THE 300 MIXER

Equalization can be used to alter the tonality of a signal. Unfortunately, the same ability to favorably change one signal may result in an unfavorable alteration in another. When using EQ, care must always be taken to not "over-do it". While we can describe the mechanics of the EQ section found on the 300 Series, we *cannot* offer specific control settings for achieving the "best" results. Our idea of what sounds best may not be the same as yours, so once again, we will only describe the science or objective portion. The subjective portion of the art of applying this knowledge properly must remain the responsibility of the person performing the mix.

The EQ section found in the 300 Series is a three band semi-parametric or sweep-type design with a shelving type high frequency portion. Both the low frequency and midrange portions have two controls each. One control determines the center frequency of the affected band while the second control determines the amount of boost or cut applied to the band. The frequency ranges are as follows: low frequency, 50 Hz-1 kHz; midrange, 200 Hz - 3 kHz. Both offer 15 dB boost or cut. The high frequency circuit is fixed at 10 kHz with 12 dB of boost or cut.

When mixing an input signal, the first decision regarding equalization is whether any EQ is needed. If not, you can bypass the unused electronics by releasing the EQ ON switch.

If EQ is desired, begin by determining which band requires alteration. Sometimes more than one portion of a single signal requires changing: thus, it is possible to boost or cut all three sections of the equalizer. Usually, however, only one band will need to be adjusted. Keep in mind, there are two ways to alter the tonality of a signal using EQ. One is to adjust the specific controls which affect the desired frequency range. The second way involves making the opposite adjustment to the other portions of the signal. For example, if a vocal signal is a little too bass heavy or "boomy", one way to correct the problem is to reduce the low frequency content. This is the direct method. The second method provides the same end result but is indirect. . . by increasing the amount of mid and high frequency signal content, the "boominess" may come in handy on those occasions where the direct approach doesn't yield the desired

results.

Once you have determined that 1) the signal *does* require EQ, and 2) the proper frequency range has been identified, the final steps involve turning the proper controls. Sounds simple, doesn't it? But if the proper range is either low or mid range, there are two controls to adjust, so how will you adjust the FREQUENCY control correctly? The technique is actually rather simple: first, adjust the GAIN control of the band so there is an exaggerated amount of boost or cut, then, slowly sweep the FREQUENCY control through its entire range. As the control is turned, you will hear the change in the signal's content. When the desired frequency is isolated, set the GAIN control to the necessary amount of boost or cut required for the desired change. Whenever possible, avoid making these changes during an actual performance or recording. The sweeping action can create an undesired effect.

The illustration shows how different instruments will be affected by changes in EQ settings, and indicates how some instruments will be unaffected by changes in one EQ band. Cymbals and flutes, for instance, would not be altered much by changes in the low frequency section, especially if the FREQUENCY control was set below the 12 o'clock position. This is because these instruments have very little signal content in this range. On the other hand, the sweep capability allows you to boost or cut specific parts of signals or instruments without altering the sound of other signals. On drums, for instance, the kick or bass drum can be brought out by carefully turning the low frequency section of the EQ, thus allowing the one drum to sound more prominent than the rest. The same technique can be used on vocals or any multiple mix of signals, as long as the various components operate normally in slightly different frequency ranges.

As with all other aspects of mixing audio, experience will help you learn the capabilities and limits of the EQUALIZER. No amount of tonal change can, for example, correct instruments which are out of tune or signals which are distorted.

To help you learn and properly respect the capabilities of the EQUALIZER section, we offer these two guidelines:

- 1). The BEST equalization is *non at all*.
- 2). If EQ is required, use the *least amount possible* to perform the task.

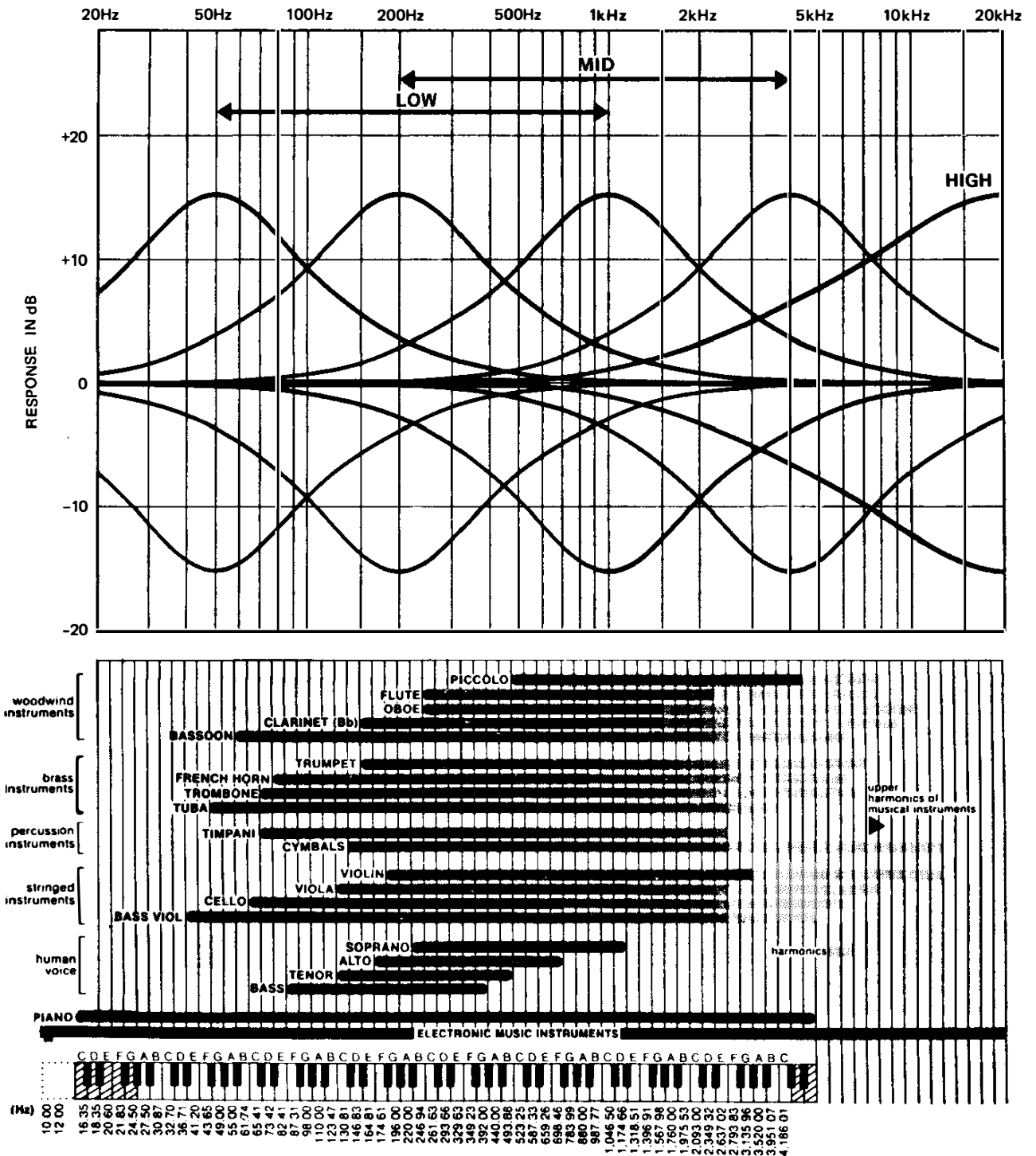

Pre & Post EQ When Using a Limiter

Many engineers like to EQ the low end before limiting to help avoid excessive "pumping" of the signal. If this is what you want to do, and, you have another channel free, do this: Take the DIRECT OUT from the first *Input Channel*, go to the limiter, use the first channel for your send, and *Don't Assign The First Channel To Any Output!*

It is not going to have all of your signal control modifications and will not be limited. To reach a BUSS, patch from the limiter out to the second *Input Channel's* INSERT jack. Now you can set the limiter input level with the first channel's TRIM and fader, do part of your EQ, and run your final signal with the second channel's fader. You will have EQ available both before and after the limiter with the minimum of electronic stages. This "patch" is also recommended when pre & post EQ are desired for use with any signal processing unit and will also give you "double EQ" using the smallest possible electronic package for those stubborn processing jobs that only brute force will fix.

A WORD OF MIXING ADVICE

All finished mixes must be balanced — each individual signal and its contents judged by how well it blends and augments the other signals. Don't rely on EQ to create the "perfect" individual sound, because the minute you add your perfect sound back into the remaining mix, the signal's tone may not be so "perfect". Always try to make the mix as near to ideal as possible before beginning the equalization process. The results will be superior to those mixes which rely heavily on extreme EQ settings.

Also keep in mind the important relationships between the input TRIM controls and the channel faders as well as the relationship between the channel and PGM GROUP faders. If the TRIM is too low, the channel fader may have to be set too high. This can result in poor signal-to-noise performance. If, on the other hand, the TRIM is too high, the result may be reduction of headroom and possibly distortion. Try to always balance the TRIM and channel fader levels so the desired sound is obtained when the fader is setting at or near the shaded portion of the fader scale, 7 to 8.

The relationship between the channel and group faders is equally important. If the channel faders are all the way up, as shown below, while the group faders are set much lower, you are probably overdriving the output stages, causing reduced headroom and distortion.

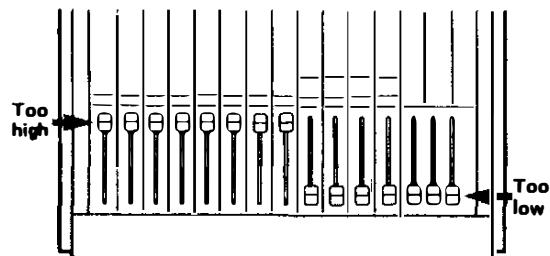

Conversely, if the channel faders are set too low while the group faders are wide open, the signal won't be distorted, but it will probably be excessively noisy. This second illustration shows this type of error.

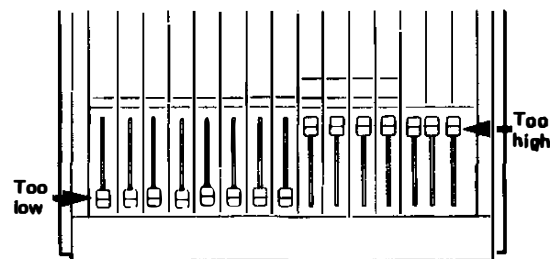

Ideally, the faders should all be set in about the same relative positions. Obviously, there will always be situations and signals which cannot be set to our "ideal" positions, so reasonable compromises in the various control settings are not uncommon.

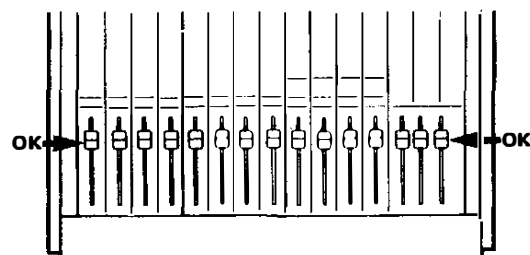

ACCESSORIES FOR THE 300 SERIES MIXERS

MC-701G Gooseneck Microphone

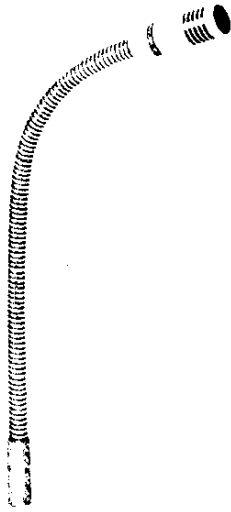

The MC-701G is a moving-coil dynamic microphone with a unidirectional pickup pattern. Originally designed for use as a high-quality talkback mic to be plugged into the TASCAM 300 Series Mixers, the MC-701G can also be used as a general purpose panel-jack-plug-in microphone.

PW-2Y/PW-4Y Insertion Cable

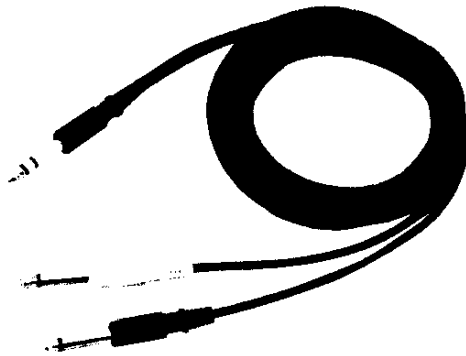

The TASCAM PW-2Y/PW-4Y is a connecting cable that allows signal processing such as a graphic equalizer to be inserted at specific points of the signal path of the 300 Series Mixers. Its tip-ring-sleeve plug connects to the INSERT jack while its "Y'ed" end accommodates connection to the input and output terminals of the out-board equipment being used. Available in two lengths – 2 m (PW-2Y) and 4 m (PW-4Y).

MH-40B Headphone Amplifier

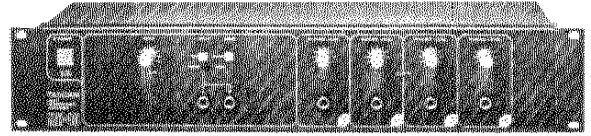

The MH-40B is a headphone distribution amplifier that can be used to feed four sets of studio cue headphones and can be mounted in a 19" EIA rack.

TZ-23 Fader-Link Knobs

The TZ-23 is used to link pairs of faders together providing the easiest and most consistent way to accomplish cross-fades. One set includes six (6) knobs.

The PB-64 Patch Bay

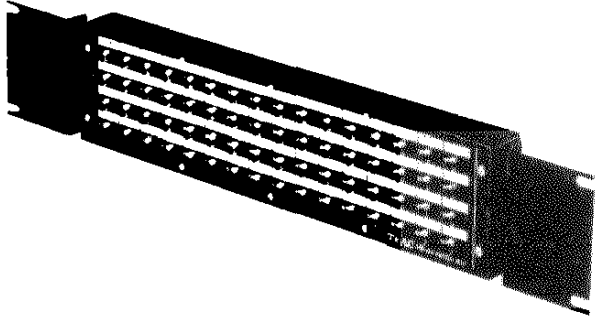

When your system begins to expand beyond the basic, sorting out where things go can take much time away from the recording process. This accessory will allow you to speed things up and get back to what you really want to do. Sixty-four RCA pins on a panel. So you can bring all those jacks to where you are. It will get you off the floor and back to recording. Connect all your inputs and outputs to the back, and you can reroute your signals with short jumpers quickly.

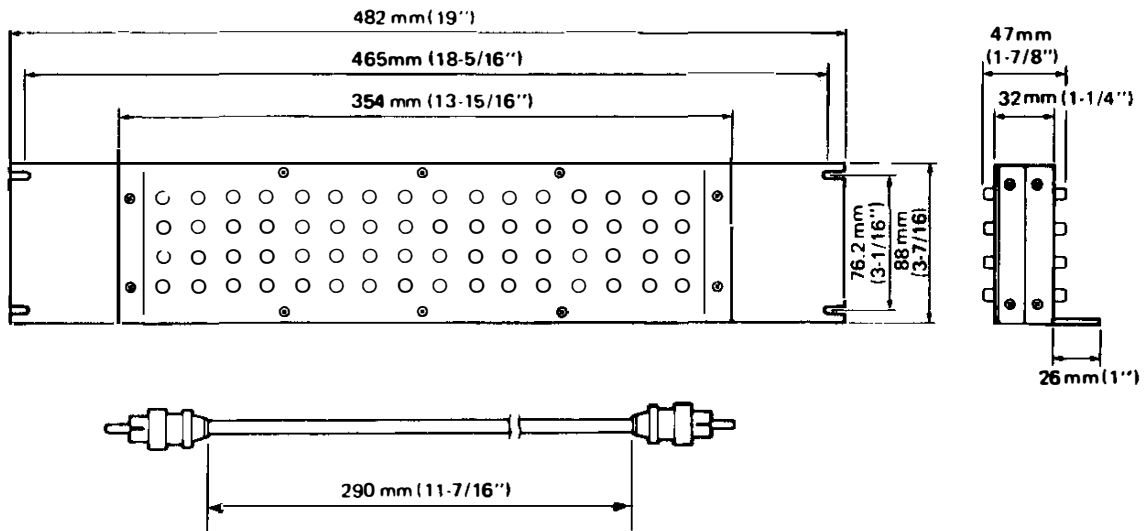

TASCAM PB-32 Series Patch Bays



(Model PB-32P)

The PB-32 Series Patch Bays are ideal for any application in multitack recording process. They are available in four basic configurations, and can be mounted in 19" EIA rack. They also feature "normalled" connections to provide the maximum in patching convenience without the need to patch through unused circuits.

Specifications

Number of circuits:	16
Type of jacks:	RCA jacks and/or 1/4" phone jacks
	Front jacks with switches: white
	Rear jacks without switches: red
Dimensions:	482 x 44 x 75
(W x H x D)	(19" x 1-3/4" x 3")
Weight:	1.3 kg (2-14/16 lbs.)

Model name	Type of jacks	Internal circuit connection	
		(FRONT)	(REAR)
PB-32P	1/4" phone jack (front and rear)	Upper	
		Lower	
PB-32R	RCA jack (front and rear)	Upper	
		Lower	
PB-32H	1/4" phone jack (front) RCA jack (rear)	Upper	
		Lower	
PB-32W	1/4" phone jack (leftmost 12 jacks, front and rear)	Leftmost 12 jacks (same as PB-32P)	
		Upper	
		Lower	
		Rightmost 20 jacks (same as PB-32R)	
	RCA jack (rightmost 20 jacks, front and rear)	Upper	
Lower			

External Dimensions

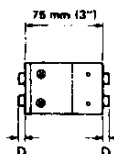
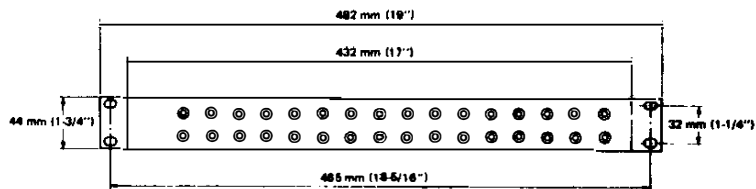

D : 2 mm (1/16") (1/4" phone jacks)
7 mm (1/4") (RCA jacks)

TASCAM Cables

Cable, because of its inherent capacitance and resistance, is an active component in an audio system. There are vast differences in cable design and performance that have significant effect on the sound quality you'll get from your equipment. TASCAM Professional Audio Cables are the best available.

Our cables feature very low capacitance (under 15 picofarads/foot) so they don't act as low pass filters and roll off high frequencies. The capacitance is also consistent; it doesn't change when the cable is bent or compressed. You don't get noise or degraded results when the cable has been used a while. Our cable's long term stability is provided by a special insulator that is as flexible as foam core dielectrics, but far more resistant to extreme cold or heat, and it doesn't let the center strands migrate. It also avoids the possibility of shearing the center conductor when the cable is crushed, so the cable does not suddenly fail.

Rather than loosely braided shield or spiral wrapped shield that can open up, we use bare copper braided shield with 97 % coverage. This excludes electrostatic noise (buzz) and RFI (CB interference, etc.). We also use a 7-strand center conductor: 4 pure copper strands for minimum resistance and 3 copper weld stainless steel strands for strength. The multiple strands increase flexibility and strength while offering less resistance at ultra high frequencies due to increased surface area for the "skin effect." This improves transient response.

The outer PVC insulating jacket resists abrasion, and is tightly fitted to the shield so it will not elongate. The connectors are special, too. Their nickel plated brass center pins are a bit longer than most to establish good contact in all RCA jacks. The cadmium plated steel outer shell includes a gentle ridge which burnishes the mating jack when the connector is twisted to ensure good contact. For maximum RF shielding, the braid is terminated inside the shell and 2-radian soldered, not just spot soldered, for maximum strength. The plugs are clad with an oval jacket of molded plastic to further increase strength and make the ends easier to handle. TASCAM cable is available in lengths from 6 inches to 20 feet, or in color-coded sets of 8 for fast channel or function identification.

TASCAM cable is also available in 500 foot spools.

If TASCAM professional cables are not available in your area, please try to find the next best cables. It really does make a difference in system performance.

M-308 SPECIFICATIONS

MECHANICAL CHARACTERISTICS

Input Selector	MIC/LINE
Fader Length	100 mm
Assign	Odd (1, 3, L/ Even (2, 4, R)
AUX Select	AUX 1 Pre Equalizer/Line AUX 2 AUX 1/Post Fader, switchable
Monitor Select Matrix	Stereo, Ext 1, Ext 2, Mono/Effect, Aux 1/2
Motor Select Switch	1-4: PGM 1-4, TAPE RTN 1-4/5-8 L, R: Stereo, Ext 1, Ext 2, Mono/Effect, Aux 1/2, switchable
Dimensions (W x H x D)	584 x 220 x 692 mm (23" x 8-11/16" x 27-1/4")
Weight (net)	21 kg (46.5/16 lbs)

ELECTRICAL CHARACTERISTICS

Mic Input	
Mic Impedance	200 ohms to 600 ohms nominal
Input Impedance	2.8 k ohms
Nominal Input Level	-60 dBV (1 mV)
Minimum Input Level	-70 dBV (0.3 mV)
Maximum Input Level	+32 dBV (40 V) +34.2 dBm (40 V)
Attenuation	30dB
Line Input	
Input Impedance	16 k ohms
Nominal Input Level	-10 dBV (0.3 V)
Minimum Input Level	-20 dBV (0.1 V)
Equalizer	
Type	Shelving-High Sweepable-Middle, Low 10 kHz (High)
Frequency	200 – 4 kHz (Middle) 50 – 1 kHz (Low)
Boost/Cut	±12dB (High) ±15 dB (Middle, Low)
Channel Overload Indicator	Set to light at 25 dB above nominal
Channel Insertion	
Output Impedance	100 ohms
Minimum Load Impedance	2 k ohms
Nominal Load Impedance	10 k ohms
Nominal Output Level	-10 dBV (0.3 V)
Maximum Output Level	+18 dBV (8 V)
Input Impedance	5 k ohms
Nominal Input Level	-10 dBV (0.3 V)
Maximum Input Level	+11 dBV (3.5 V)

Direct Output	
Output Impedance	100 ohms
Minimum Load Impedance	2 k ohms
Nominal Load Impedance	10 k ohms
Nominal Output Level	-10 dBV (0.3 V)
Maximum Output Level	+18 dBV (8 V)
Bus (Sub) Input (PGM/STEREO/EFFECT/AUX)	
Input Impedance	22 k ohms
Nominal Input Level	-10 dBV (0.3 V)
Maximum Input Level	+18 dBV (8 V)
PGM Insertion	
Output Impedance	100 ohms
Minimum Load Impedance	2 k ohms
Nominal Load Impedance	10 k ohms
Nominal Output Level	-10 dBV (0.3 V)
Maximum Output Level	+18 dBV (8 V)
Input Impedance	9 k ohms
Nominal Input Level	-10 dBV (0.3 V)
Maximum Input Level	+11 dBV (3.5 V)
PGM Output	
XLR Type	
Output Impedance	20 ohms
Minimum Load Impedance	200 ohms
Nominal Load Impedance	600 ohms
Nominal Output Level	+4 dBm (1.25 V)
Maximum Output Level	+25 dBm (14 V) Balanced +20dBm (8 V) Unbalanced
RCA	
Output Impedance	100 ohms
Minimum Load Impedance	2 k ohms
Nominal Load Impedance	10 k ohms
Nominal Output Level	-10 dBV (0.3 V)
Maximum Output Level	+18 dBV (8 V)
AUX Output	
1/4"	
Output Impedance	20 ohms
Minimum Load Impedance	2 k ohms
Nominal Load Impedance	10 k ohms
Nominal Output Level	0 dBu (0.78 V)
Maximum Output Level	+20 dBu (8 V)
RCA	
Output Impedance	490 ohms
Minimum Load Impedance	2 k ohms
Nominal Load Impedance	10 k ohms
Nominal Output Level	-10 dBV (0.3 V)
Maximum Output Level	+10 dBV (3.1 V)
Effect Output	
1/4"	
Output Impedance	20 ohms
Minimum Load Impedance	2 k ohms
Nominal Load Impedance	10 k ohms
Nominal Output Level	0 dBu (0.78 V)
Maximum Output Level	+20 dBu (8 V)
RCA	
Output Impedance	490 ohms
Minimum Load Impedance	2 k ohms

Nominal Load Impedance	10 k ohms
Nominal Output Level	-10 dBV (0.3 V)
Maximum Output Level	+10 dBV (3.1 V)
Effect Return Input	
Input Impedance	3.5 k ohms
Nominal Input Level	0 dBu (0.78 V)
Minimum Input Level	-10 dBu (0.25 V)
Tape Return Input	
Input Impedance	12 k ohms
Nominal Input Level	-10 dBV (0.3 V)
Minimum Input Level	-20 dBV (0.1 V)
Stereo Insertion	
Output Impedance	100 ohms
Minimum Load Impedance	2 k ohms
Nominal Load Impedance	10 k ohms
Nominal Output Level	-10 dBV (0.3 V)
Maximum Output Level	+18 dBV (8 V)
Input Impedance	7 k ohms
Nominal Input Level	-10 dBV (0.3 V)
Maximum Input Level	+11 dBV (3.5 V)
Mono Insertion	
Output Impedance	100 ohms
Minimum Load Impedance	2 k ohms
Nominal Load Impedance	10 k ohms
Nominal Output Level	-10 dBV (0.3 V)
Maximum Output Level	+18 dBV (8 V)
Input Impedance	6 k ohms
Nominal Input Level	-10 dBV (0.3 V)
Maximum Input Level	+11 dBV (3.5 V)
External Input	
Input Impedance	8 k ohms
Nominal Input Level	-10 dBV (0.3 V)
Maximum Input Level	+18 dBV (8 V)
Stereo Output	
XLR Type	
Output Impedance	20 ohms
Minimum Load Impedance	200 ohms
Nominal Load Impedance	600 ohms
Nominal Output Level	+4 dBm (1.25 V)
Maximum Output Level	+25 dBm (14 V) Balanced +20dBm (8 V) Unbalanced
RCA	
Output Impedance	100 ohms
Minimum Load Impedance	2 k ohms
Nominal Load Impedance	10 k ohms
Nominal Output Level	-10 dBV (0.3 V)
Maximum Output Level	+18 dBV (8 V)
Mono Output	
XLR Type	
Output Impedance	20 ohms
Minimum Load Impedance	200 ohms
Nominal Load Impedance	600 ohms
Nominal Output Level	+4 dBm (1.25 V)
Maximum Output Level	+25 dBm (14 V) Balanced +20dBm (8 V) Unbalanced

1/4"	
Output Impedance	20 ohms
Minimum Load Impedance	2 k ohms
Nominal Load Impedance	10 k ohms
Nominal Output Level	0dBu (0.78 V)
Maximum Output Level	+20dBu (8V)
Monitor Output	
1/4"	
Output Impedance	22 ohms
Minimum Load Impedance	2 k ohms
Nominal Load Impedance	10 k ohms
Nominal Output Level	0 dBu (0.78 V)
Maximum Output Level	20dBu (8 V)
RCA	
Output Impedance	490ohms
Minimum Load Impedance	2 k ohms
Nominal Load Impedance	10 k ohms
Nominal Output Level	-10 dBV (0.3 V)
Maximum Output Level	+10 dBV (3.1 V)
Solo Input	
Input Impedance	22 k ohms
Nominal Input Level	-10 dBV (0.3V)
Maximum Input Level	+18dBV (8V)
Solo Output	
Output Impedance	100 ohms
Minimum Load Impedance	2 k ohms
Nominal Load Impedance	10 k ohms
Nominal Output Level	-10 dBV (0.3 V)
Maximum Output Level	+18 dBV (8V)
Headphone Output	
Load Impedance	8 ohms, stereophones
Maximum Output Level	1.5W+1.5W
Meter	
Peak Indicator Level	6, VU Type
	10 dB above nominal output level
Fader Attenuation (1 kHz)	80 dB
Power Requirements	
U.S.A./CANADA	120 V AC, 60 Hz, 41 W
Europe	220 V AC, 60 Hz, 41 W
U.K./Australia	240 V AC, 50 Hz, 41 W
General Export	100/120/220/240 V AC, 60/60 Hz, 41 W

Total Harmonic Distortion (THD)	
1 Mic Input to 1 PGM Output	0.025 % (20 Hz – 20kHz, EO OUT, 50 dB above nominal input level and MIC ATT 30 dB on, with 30kHz L.P.F. connected)
1 Line Input to 1 PGM Output	0.02 % (20 Hz – 20kHz, EO OUT, nominal input level, with 30kHz L.P.F. connected)
Intermodulation Distortion (IMD), (SMPTE Method)	
1 Mic Input to 1 PGM Output	0.06 % (EO OUT, 50 dB above nominal input level and MIC ATT 30 dB on)
1 Line Input to 1 PGM Output	0.045 % (EO OUT, nominal input level)
Frequency Response	
Mic Input to PGM Output	20 – 30 kHz +1 dB -2dB
Line Input to Any Output	20 – 30 kHz +1 dB -2dB
Cross-Talk, At 1 kHz	
At 18 kHz	Better than 70 dB
	Better than 60 dB

In these specifications: 0 dBV is referenced to 1.0 Volt; 0dBu and dBm are referenced to 0.776 Volt. Actual voltage levels are also given in parenthesis (0.316 Volt for -10dBV is rounded off and given as 0.3 Volt, and 0.775 Volt for 0 dBu as 0.78 Volt). Changes in specifications and features may be made without notice or obligation.

PERFORMANCE CHARACTERISTICS

Equivalent Input Noise	DIN Audio/"A" Wtd
150ohm source	-130 dB/-132dB
Signal-to-Noise Ratio	DIN Audio/"A" Wtd
3 Mic to PGM Output	60 dB/62 dB
1 Line to PGM Output	86 dB/87 dB
8 Line to PGM Output	80 dB/82 dB
1 Line to Effect/Aux Output	85 dB/87 dB
1 Line to Stereo Output	86 dB/88 dB
1 Line to Mono Output	83 dB/85 dB
1 Line to Monitor Output	84 dB/86 dB
1 Line to Solo Output	86 dB/88 dB

M-312 SPECIFICATIONS

MECHANICAL CHARACTERISTICS

Input Selector	MIC/LINE
Fader Length	100 mm
Assign	Odd (1, 3, L)/ Even (2, 4, R)
AUX Select	AUX 1 Pre Equalizer/Line AUX 2 AUX 1/Post Fader AUX 3, 4 PGM Buss/TAPE RTN Pre Fader/Post Fader, switchable
Monitor Select Matrix	Stereo, Ext 1, Ext 2, Mono/Effect, Aux 1/2, Aux 3/4
Meter Select Switch	1-4: PGM 1-4, TAPE RTN 1-4/5-8 L, R: Stereo, Ext 1, Ext 2, Mono/Effect, Aux 1/2, Aux 3/4 switchable
Dimensions (W x H x D)	720 x 220 x 692 mm (28-3/8" x 8-11/16" x 27-1/4")
Weight (net)	26 kg (57-5/16 lbs.)

ELECTRICAL CHARACTERISTICS

Mic Input	
Mic Impedance	200 ohms to 600 ohms nominal
Input Impedance	2,8 k ohms
Nominal Input Level	-60dBV (1 mV)
Minimum Input Level	-70 dBV (0.3 mV)
Maximum Input Level	+32 dBV (40 V) +34.2 dBm (40 V)
Attenuation	30dB
Line Input	
Input Impedance	16 k ohms
Nominal Input Level	-10dBV (0.3 V)
Minimum Input Level	-20 dBV (0.1 V)
Equalizer	
Type	Shelving-High Sweepable-Middle, Low
Frequency	10 kHz (High) 200 – 4 kHz (Middle) 50 – 1 kHz (Low)
Boost/Cut	±12 dB (High) ±15 dB (Middle, Low)
Channel Overload Indicator	Set to light at 25 dB above nominal
Channel Insertion	
Output Impedance	100 ohms
Minimum Load Impedance	2 k ohms
Nominal Load Impedance	10 k ohms
Nominal Output Level	-10dBV (0.3 V)

Maximum Output Level	+18 dBV (8 V)
Input Impedance	5 k ohms
Nominal Input Level	-10 dBV (0.3 V)
Maximum Input Level	+11 dBV (3.5 V)
Direct Output	
Output Impedance	100 ohms
Minimum Load Impedance	2 k ohms
Nominal Load Impedance	10 k ohms
Nominal Output Level	-10 dBV (0.3 V)
Maximum Output Level	+18 dBV (8 V)
Buss (Sub) Input (PGM/STEREO/EFFECT/AUX)	
Input Impedance	22 k ohms
Nominal Input Level	-10 dBV (0.3 V)
Maximum Input Level	+18 dBV (8 V)
PGM Insertion	
Output Impedance	100 ohms
Minimum Load Impedance	2 k ohms
Nominal Load Impedance	10 k ohms
Nominal Output Level	-10 dBV (0.3 V)
Maximum Output Level	+18 dBV (8 V)
Input Impedance	9 k ohms
Nominal Input Level	-10 dBV (0.3 V)
Maximum Input Level	+11 dBV (3.5 V)
PGM Output	
XLR Type	
Output Impedance	20 ohms
Minimum Load Impedance	200 ohms
Nominal Load Impedance	600 ohms
Nominal Output Level	+4 dBm (1.25 V)
Maximum Output Level	+25 dBm (14 V) Balanced +20dBm (8 V) Unbalanced
RCA	
Output Impedance	100 ohms
Minimum Load Impedance	2 k ohms
Nominal Load Impedance	10 k ohms
Nominal Output Level	-10 dBV (0.3 V)
Maximum Output Level	+18 dBV (8 V)
AUX Output	
1/4"	
Output Impedance	20 ohms
Minimum Load Impedance	2 k ohms
Nominal Load Impedance	10 k ohms
Nominal Output Level	0dBu (0.78 V)
Maximum Output Level	+20dBu (8 V)
RCA	
Output Impedance	490 ohms
Minimum Load Impedance	2 k ohms
Nominal Load Impedance	10 k ohms
Nominal Output Level	-10dBV (0.3 V)
Maximum Output Level	+10dBV (3.1 V)
Effect Output	
1/4"	
Output Impedance	20 ohms
Minimum Load Impedance	2 k ohms
Nominal Load Impedance	10 k ohms
Nominal Output Level	0 dBu (0.78 V)
Maximum Output Level	+20dBu (8 V)

RCA	
Output Impedance	490 ohms
Minimum Load Impedance	2 k ohms
Nominal Load Impedance	10 k ohms
Nominal Output Level	-10 dBV (0.3 V)
Maximum Output Level	+10 dBV (3.1 V)
Effect Return Input	
Input Impedance	3.5 k ohms
Nominal Input Level	0 dBu (0.78 V)
Minimum Input Level	-10 dBu (0.25 V)
Tape Return Input	
Input Impedance	12 k ohms
Nominal Input Level	-10 dBV (0.3 V)
Minimum Input Level	-20 dBV (0.1 V)
Stereo Insertion	
Output Impedance	100 ohms
Minimum Load Impedance	2 k ohms
Nominal Load Impedance	10 k ohms
Nominal Output Level	-10dBV (0.3 V)
Maximum Output Level	+18 dBV (8 V)
Input Impedance	7 k ohms
Nominal Input Level	-10 dBV (0.3 V)
Maximum Input Level	+11 dBV (3.5 V)
Mono Insertion	
Output Impedance	100 ohms
Minimum Load Impedance	2 k ohms
Nominal Load Impedance	10 k ohms
Nominal Output Level	-10 dBV (0.3 V)
Maximum Output Level	+18 dBV (8 V)
Input Impedance	6 k ohms
Nominal Input Level	-10 dBV (0.3 V)
Maximum Input Level	+11 dBV (3.5 V)
External Input	
Input Impedance	8 k ohms
Nominal Input Level	-10 dBV (0.3 V)
Maximum Input Level	+18 dBV (8 V)
Stereo Output	
XLR Type	
Output Impedance	20 ohms
Minimum Load Impedance	200 ohms
Nominal Load Impedance	600 ohms
Nominal Output Level	+4 dBm (1.25 V)
Maximum Output Level	+25 dBm (14 V) Balanced +20dBm (8 V) Unbalanced
RCA	
Output Impedance	100 ohms
Minimum Load Impedance	2 k ohms
Nominal Load Impedance	10 k ohms
Nominal Output Level	-10 dBV (0.3 V)
Maximum Output Level	+18 dBV (8 V)
Mono Output	
XLR Type	
Output Impedance	20 ohms
Minimum Load Impedance	200 ohms
Nominal Load Impedance	600 ohms
Nominal Output Level	+4 dBm (1.25 V)

Maximum Output Level	+25dBm (14 V) Balanced +20dBm (8 V) Unbalanced
1/4"	
Output Impedance	20 ohms
Minimum Load Impedance	2 k ohms
Nominal Load Impedance	10 k ohms
Nominal Output Level	0 dBu (0.78 V)
Maximum Output Level	+20dBu (8V)
Talkback Mic Input	
Input Impedance	9 k ohms
Mic Impedance	200 to 600 ohms
Nominal Input Level	-50 dBV (3 mV)
Minimum Input Level	-80dBV (1 mV)
Maximum Input Level	+9 dBV (2.8 V)
Monitor Output	
1/4"	
Output Impedance	22 ohms
Minimum Load Impedance	2 k ohms
Nominal Load Impedance	10 k ohms
Nominal Output Level	0 dBu (0.78 V)
Maximum Output Level	20dBu (8V)
RCA	
Output Impedance	490 ohms
Minimum Load Impedance	2 k ohms
Nominal Load Impedance	10 k ohms
Nominal Output Level	-10 dBV (0.3 V)
Maximum Output Level	+10dBV (3.1 V)
Solo Input	
Input Impedance	22 k ohms
Nominal Input Level	-10 dBV (0.3 V)
Maximum Input Level	+18 dBV (8 V)
Solo Output	
Output Impedance	100 ohms
Minimum Load Impedance	2 k ohms
Nominal Load Impedance	10 k ohms
Nominal Output Level	-10 dBV (0.3 V)
Maximum Output Level	+18 dBV (8 V)
Headphone Output	
Load Impedance	8 ohms, stereophones
Maximum Output Level	1.5 W +1.5 W
Meter	6, VU Type
Peak Indicator Level	10 dB above nominal output level
Fader Attenuation (1 kHz)	80 dB
Power Requirements	
U.S.A./CANADA	120 V AC, 60 Hz, 46 W
Europe	220 V AC, 50 Hz, 46 W
U.K./Australia	240 V AC, 50 Hz, 46 W
General Export	100/120/220/240 V AC, 50/60 Hz, 46 W

PERFORMANCE CHARACTERISTICS

Equivalent Input Noise	DIN Audio/"A" Wtd 150ohm source	-130 dB/-132 dB
Signal-to-Noise Ratio	DIN Audio/"A" Wtd	
12 Mic to PGM Output		52 dB/58 dB
1 Line to PGM Output		86 dB/87 dB
12 Line to PGM Output		77 dB/80 dB
1 Line to Effect/Aux Output		82 dB/84 dB
1 Line to Stereo Output		85 dB/87 dB
1 Line to Mono Output		83 dB/85 dB
1 Line to Monitor Output		84 dB/86 dB
1 Line to Solo Output		86 dB/88 dB
Total Harmonic Distortion (THD)		
1 Mic Input to 1 PGM Output	0.025 % (20 Hz – 20kHz, EQ OUT, 50 dB above nominal input level and MIC ATT 30dB on, with 30kHz L.P.F. connected)	
1 Line Input to 1 PGM Output	0.02 % (20 Hz – 20kHz, EQ OUT, nominal input level, with 30kHz L.P.F. connected)	
Intermodulation Distortion (IMD), (SMPTE Method)		
1 Mic Input to 1 PGM Output	0.06 % (EQ OUT, 50 dB above nominal input level and MIC ATT 30dB on)	
1 Line Input to 1 PGM Output	0.045 % (EQ OUT, nominal input level)	
Frequency Response		
Mic Input to PGM Output	20 – 30 kHz	+1 dB -2 dB
Line Input to Any Output	20 – 30 kHz	+1 dB -2 dB
Cross-Talk, At 1 kHz		Better than 70 dB
At 18 kHz		Better than 60 dB

In these specifications: 0 dBV is referenced to 1.0 Volt; 0 dBu and dBm are referenced to 0.775 Volt. Actual voltage levels are also given in parenthesis (0.316 Volt for -10 dBV is rounded off and given as 0.3 Volt, and 0.775 Volt for 0 dBu as 0.78 Volt). Changes in specifications and features may be made without notice or obligation.

M-320 SPECIFICATIONS

MECHANICAL CHARACTERISTICS

Input Selector	MIC/LINE
Fader Length	100 mm
Assign	Odd (1, 3, L)/ Even(2, 4, R)
AUX Select	AUX 1 Pre Equalizer/Line AUX 2 AUX 1/Post Fader AUX 3, 4 PGM Buss/TAPE RTN Pre Fader/Post Fader, switchable
Monitor Select Matrix	Stereo, Ext 1, Ext 2, Mono/Effect, Aux 1/2, Aux 3/4
Meter Select Switch	1-4: PGM 1-4, TAPE RTN 1-4/5-8 L, R: Stereo, Ext 1, Ext 2, Mono/Effect, Aux 1/2, Aux 3/4 switchable
Dimensions (W x H x D)	992 x 220 x 692 mm (39-1/16" x 8-11/16" x 27-1/4")
Weight (net)	36 kg (79-6/16 lbs.)

ELECTRICAL CHARACTERISTICS

Mic Input	
Mic Impedance	200 ohms to 600 ohms nominal
Input Impedance	2,8 k ohms
Nominal Input Level	-60 dBV (1 mV)
Minimum Input Level	-70 dBV (0.3 mV)
Maximum Input Level	+32 dBV (40 V) +34.2 dBm (40 V)
Attenuation	30 dB
Line Input	
Input Impedance	16 k ohms
Nominal Input Level	-10 dBV (0.3 V)
Minimum Input Level	-20 dBV (0.1 V)
Equalizer	
Type	Shelving-High Sweepable-Middle, Low
Frequency	10 kHz (High) 200 – 4 kHz (Middle) 50 – 1 kHz (Low)
Boost/Cut	±12 dB (High) ±15 dB (Middle, Low)
Channel Overload Indicator	Set to light at 25 dB above nominal
Channel Insertion	
Output Impedance	100 ohms
Minimum Load Impedance	2 k ohms
Nominal Load Impedance	10 kohms
Nominal Output Level	-10 dBV (0.3 V)

Maximum Output Level	+18 dBV (8 V)
Input Impedance	5 k ohms
Nominal Input Level	-10 dBV (0.3 V)
Maximum Input Level	+11 dBV (3.5 V)
Direct Output	
Output Impedance	100 ohms
Minimum Load Impedance	2 k ohms
Nominal Load Impedance	10 k ohms
Nominal Output Level	-10 dBV (0.3 V)
Maximum Output Level	+18 dBV (8 V)
Buss (Sub) Input (PGM/STEREO/EFFECT/AUX)	
Input Impedance	22 k ohms
Nominal Input Level	-10 dBV (0.3 V)
Maximum Input Level	+18 dBV (8 V)
PGM Insertion	
Output Impedance	100 ohms
Minimum Load Impedance	2 k ohms
Nominal Load Impedance	10 k ohms
Nominal Output Level	-10 dBV (0.3 V)
Maximum Output Level	+18 dBV (8 V)
Input Impedance	9 k ohms
Nominal Input Level	-10 dBV (0.3 V)
Maximum Input Level	+11 dBV (3.5 V)
PGM Output	
XLR Type	
Output Impedance	20 ohms
Minimum Load Impedance	200 ohms
Nominal Load Impedance	600 ohms
Nominal Output Level	+4 dBm (1.25 V)
Maximum Output Level	+25 dBm (14 V) Balanced +20 dBm (8 V) Unbalanced
RCA	
Output Impedance	100 ohms
Minimum Load Impedance	2 k ohms
Nominal Load Impedance	10 k ohms
Nominal Output Level	-10 dBV (0.3 V)
Maximum Output Level	+18 dBV (8 V)
AUX Output	
1/4"	
Output Impedance	20 ohms
Minimum Load Impedance	2 k ohms
Nominal Load Impedance	10 k ohms
Nominal Output Level	0 dBu (0.78 V)
Maximum Output Level	+20 dBu (8 V)
RCA	
Output Impedance	490 ohms
Minimum Load Impedance	2 k ohms
Nominal Load Impedance	10 k ohms
Nominal Output Level	-10 dBV (0.3 V)
Maximum Output Level	+10 dBV (3.1 V)
Effect Output	
1/4"	
Output Impedance	20 ohms
Minimum Load Impedance	2 k ohms
Nominal Load Impedance	10 k ohms
Nominal Output Level	0 dBu (0.78 V)
Maximum Output Level	+20 dBu (8 V)

RCA	
Output Impedance	490 ohms
Minimum Load Impedance	2 k ohms
Nominal Load Impedance	10 k ohms
Nominal Output Level	-10 dBV (0.3 V)
Maximum Output Level	+10 dBV (3.1 V)
Effect Return Input	
Input Impedance	3.5 k ohms
Nominal Input Level	0 dBu (0.78 V)
Minimum Input Level	-10 dBu (0.25 V)
Tape Return Input	
Input Impedance	12 k ohms
Nominal Input Level	-10 dBV (0.3 V)
Minimum Input Level	-20 dBV (0.1 V)
Stereo Insertion	
Output Impedance	100 ohms
Minimum Load Impedance	2 k ohms
Nominal Load Impedance	10 k ohms
Nominal Output Level	-10 dBV (0.3 V)
Maximum Output Level	+18 dBV (8 V)
Input Impedance	7 k ohms
Nominal Input Level	-10 dBV (0.3 V)
Maximum Input Level	+11 dBV (3.5 V)
Mono Insertion	
Output Impedance	100 ohms
Minimum Load Impedance	2 k ohms
Nominal Load Impedance	10 k ohms
Nominal Output Level	-10 dBV (0.3 V)
Maximum Output Level	+18 dBV (8 V)
Input Impedance	6 k ohms
Nominal Input Level	-10 dBV (0.3 V)
Maximum Input Level	+11 dBV (3.5 V)
External Input	
Input Impedance	8 k ohms
Nominal Input Level	-10 dBV (0.3 V)
Maximum Input Level	+18 dBV (8 V)
Stereo Output	
XLR Type	
Output Impedance	20 ohms
Minimum Load Impedance	200 ohms
Nominal Load Impedance	600 ohms
Nominal Output Level	+4 dBm (1.25 V)
Maximum Output Level	+25 dBm (14 V) Balanced +20 dBm (8 V) Unbalanced
RCA	
Output Impedance	100 ohms
Minimum Load Impedance	2 k ohms
Nominal Load Impedance	10 k ohms
Nominal Output Level	-10 dBV (0.3 V)
Maximum Output Level	+18 dBV (8 V)
Mono Output	
XLR Type	
Output Impedance	20 ohms
Minimum Load Impedance	200 ohms
Nominal Load Impedance	600 ohms
Nominal Output Level	+4 dBm (1.25 V)

Maximum Output Level	+25 dBm (14 V) Balanced +20 dBm (8 V) Unbalanced
1/4"	
Output Impedance	20 ohms
Minimum Load Impedance	2 k ohms
Nominal Load Impedance	10 k ohms
Nominal Output Level	0 dBu (0.78 V)
Maximum Output Level	+20 dBu (8 V)
Talkback Mic Input	
Input Impedance	9 k ohms
Mic Impedance	200 to 600 ohms
Nominal Input Level	-50 dBV (3 mV)
Minimum Input Level	-60 dBV (1 mV)
Maximum Input Level	+9 dBV (2.8 V)
Monitor Output	
1/4"	
Output Impedance	22 ohms
Minimum Load Impedance	2 k ohms
Nominal Load Impedance	10 k ohms
Nominal Output Level	0 dBu (0.78 V)
Maximum Output Level	20 dBu (8 V)
RCA	
Output Impedance	490 ohms
Minimum Load Impedance	2 k ohms
Nominal Load Impedance	10 k ohms
Nominal Output Level	-10 dBV (0.3 V)
Maximum Output Level	+10 dBV (3.1 V)
Solo Input	
Input Impedance	22 k ohms
Nominal Input Level	-10 dBV (0.3 V)
Maximum Input Level	+18 dBV (8 V)
Solo Output	
Output Impedance	100 ohms
Minimum Load Impedance	2 k ohms
Nominal Load Impedance	10 k ohms
Nominal Output Level	-10 dBV (0.3 V)
Maximum Output Level	+18 dBV (8 V)
Headphone Output	
Load Impedance	8 ohms, stereophones
Maximum Output Level	1.5 W + 1.5 W
Meter	6, VU Type
Peak Indicator Level	10 dB above nominal output level
Attenuation (1 kHz)	80 dB
Power Requirements	
U.S.A./CANADA	120 V AC, 60 Hz, 75 W
Europe	220 V AC, 50 Hz, 75 W
U.K./Australia	240 V AC, 50 Hz, 75 W
General Export	100/120/220/240 V AC, 50/60 Hz, 75 W

PERFORMANCE CHARACTERISTICS

Equivalent Input Noise	DIN Audio/"A" Wtd 150 ohm source	-130 dB/-132 dB
Signal-to-Noise Ratio	DIN Audio/"A" Wtd	
20 Mic to PGM Output		50 dB/55 dB
1 Line to PGM Output		96 dB/87 dB
20 Line to PGM Output		73 dB/75 dB
1 Line to Effect/Aux Output		78 dB/80 dB
1 Line to Stereo Output		84 dB/86 dB
1 Line to Mono Output		83 dB/85 dB
1 Line to Monitor Output		84 dB/86 dB
1 Line to Solo Output		86 dB/88 dB
Total Harmonic Distortion (THD)		
1 Mic Input to 1 PGM Output	0.025% (20 Hz – 20 kHz, EQ OUT, 50 dB above nominal input level and MIC ATT 30 dB on, with 30 kHz L.P.F. connected)	
1 Line Input to 1 PGM Output	0.02% (20 Hz – 20 kHz, EQ OUT, nominal input level, with 30 kHz L.P.F. connected)	
Intermodulation Distortion (IMD), (SMPTE Method)		
1 Mic Input to 1 PGM Output	0.06% (EQ OUT, 50 dB above nominal input level and MIC ATT 30 dB on)	
1 Line Input to 1 PGM Output	0.045% (EQ OUT, nominal input level)	
Frequency Response		
Mic Input to PGM Output	20 – 30 kHz	+1 dB -2 dB
Line Input to Any Output	20 – 30 kHz	+1 dB -2 dB
Cross-Talk, At 1 kHz		Better than 70 dB
At 18 kHz		Better than 60 dB

In these specifications: 0 dBV is referenced to 1.0 Volt; 0 dBu and dBm are referenced to 0.775 Volt. Actual voltage levels are also given in parenthesis (0.316 Volt for -10 dBV is rounded off and given as 0.3 Volt, and 0.775 Volt for 0 dBu as 0.78 Volt). Changes in specifications and features may be made without notice or obligation.

VOLTAGE CONVERSION

This mixer is adjusted to operate on the electric voltage specified on the packing carton.

Note: This voltage conversion is not possible on models sold in the U.S.A. and Canada, U.K., Australia or Europe.

For general export units, if it is necessary to change the voltage requirements of this mixer to match your area, use the following procedures. **ALWAYS DISCONNECT POWER LINE CORD BEFORE MAKING THESE CHANGES.**

1. Turn the mixer upside-down on a soft surface.
2. Remove screws A (two) and B (quantity of B differs among models).
3. Remove the panel.
4. Locate the voltage selector plug near the transformer inside the unit.
5. Pull out the plug and reinsert it so that the desired voltage can be read through the cut-out window of the plug.
6. Replace the panel.

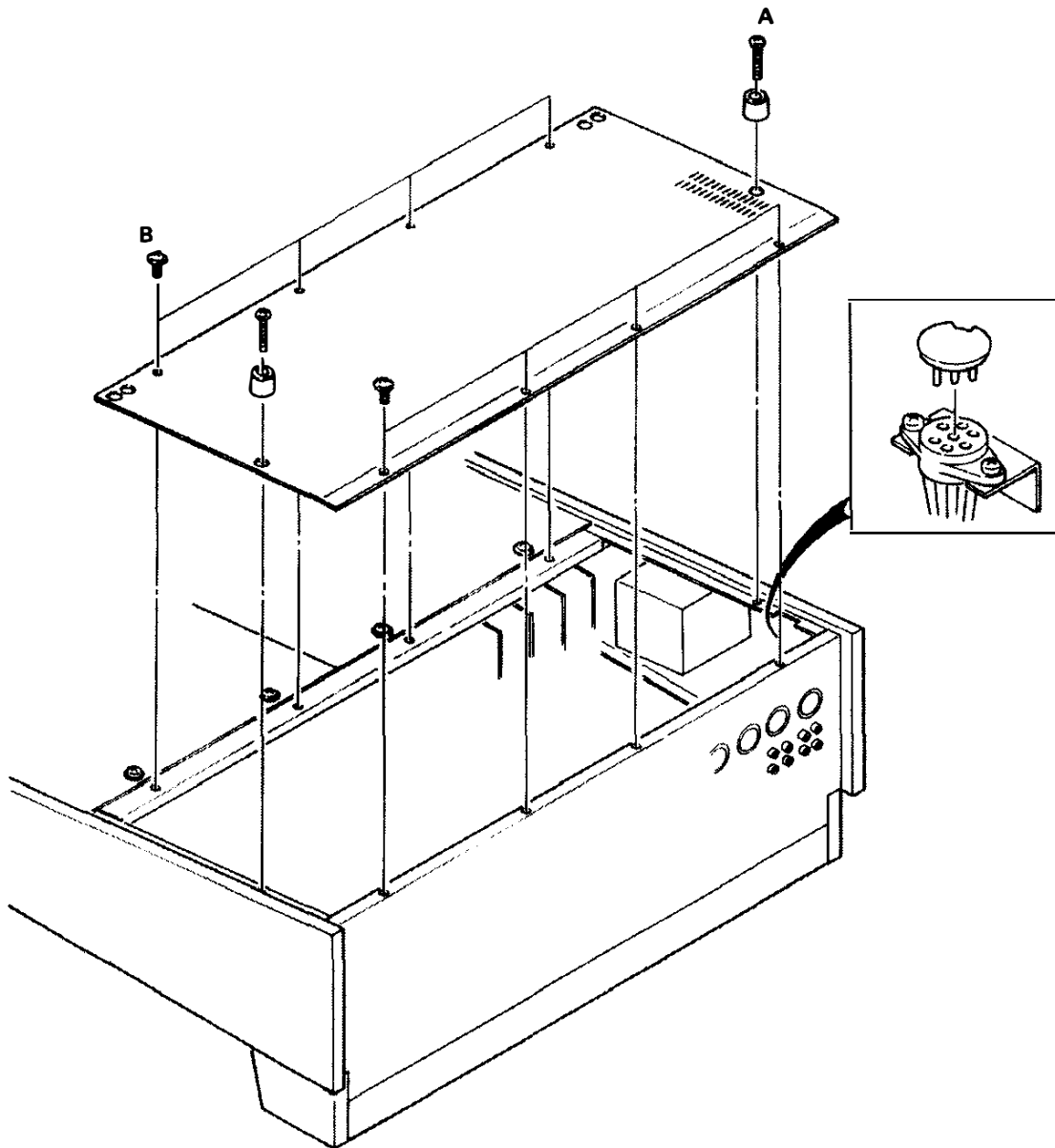

M-308 BLOCK DIAGRAM

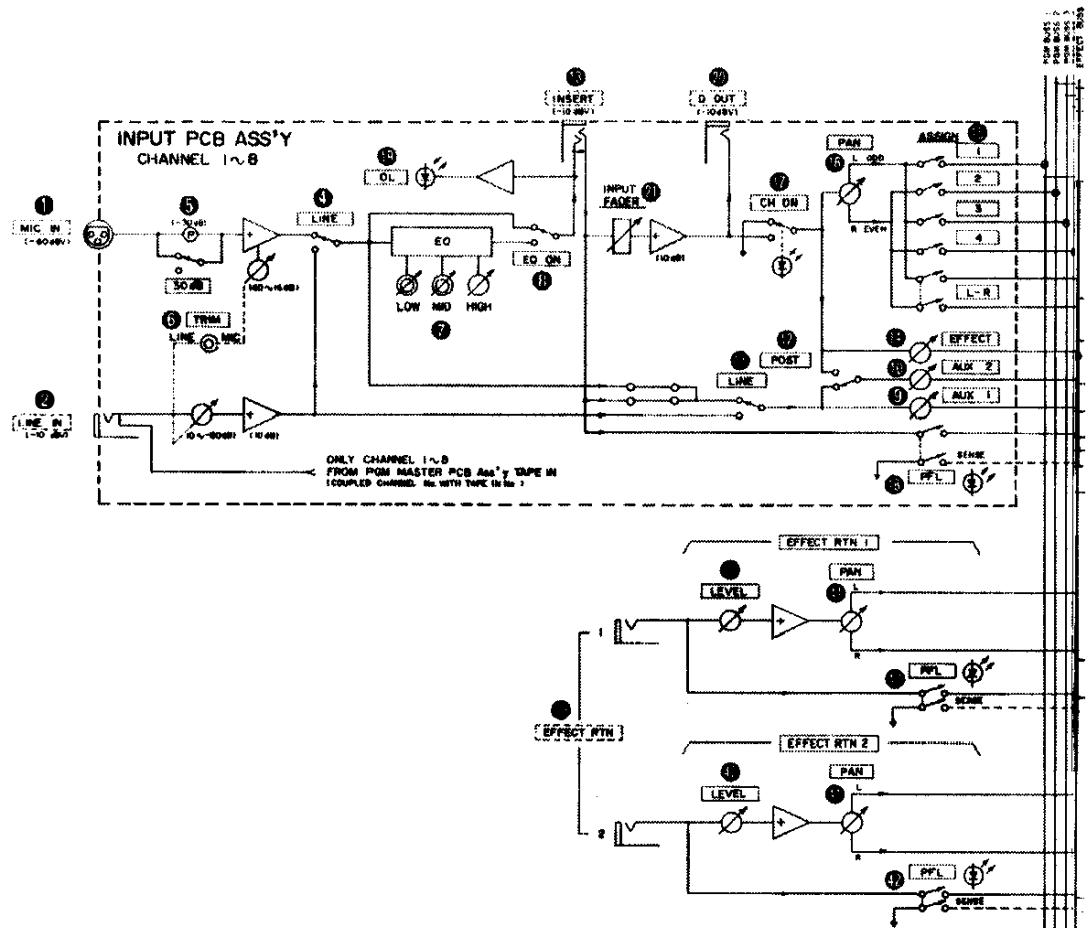

NOTE

1. UNIT
 0dBu = 1Vrms
 0dBu = 0.775Vrms
 0dBm = 0.775Vrms

2. OPERATIONAL LEVEL -10dBV

3. INPUT EQUALIZER

	GAIN	FREQUENCY
HIGH	+12dB	10KHz
MID	+15dB	200Hz ~ 4KHz
LOW	+15dB	50Hz ~ 1KHz

4. SYMBOLS

	RCA JACK		INVERTING AMP		LED
	1/4" JACK		NON INVERTING AMP		VU METER (WITH PEAK LED)
	1/4" JACK (LINED) (ONE SET)		BALANCED AMP		CONNECTION NODE
	1/4" IN - OUT JACK (INSERT BREAK)		PUSH SWITCH (100ms D)		SUMMING NODE
	1/4" STEREO JACK		ROTARY POT		GROUND
	JLR-3-31 EQUALIZER		LINEAR FADER		JUMPER WIRE
	JLR-3-32 EQUALIZER		PAN POT		CONTROL SIGNAL
	ELECTRIC SWITCH (MIN 5 ONLY)		PAD		

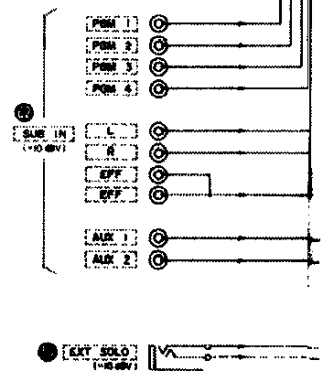

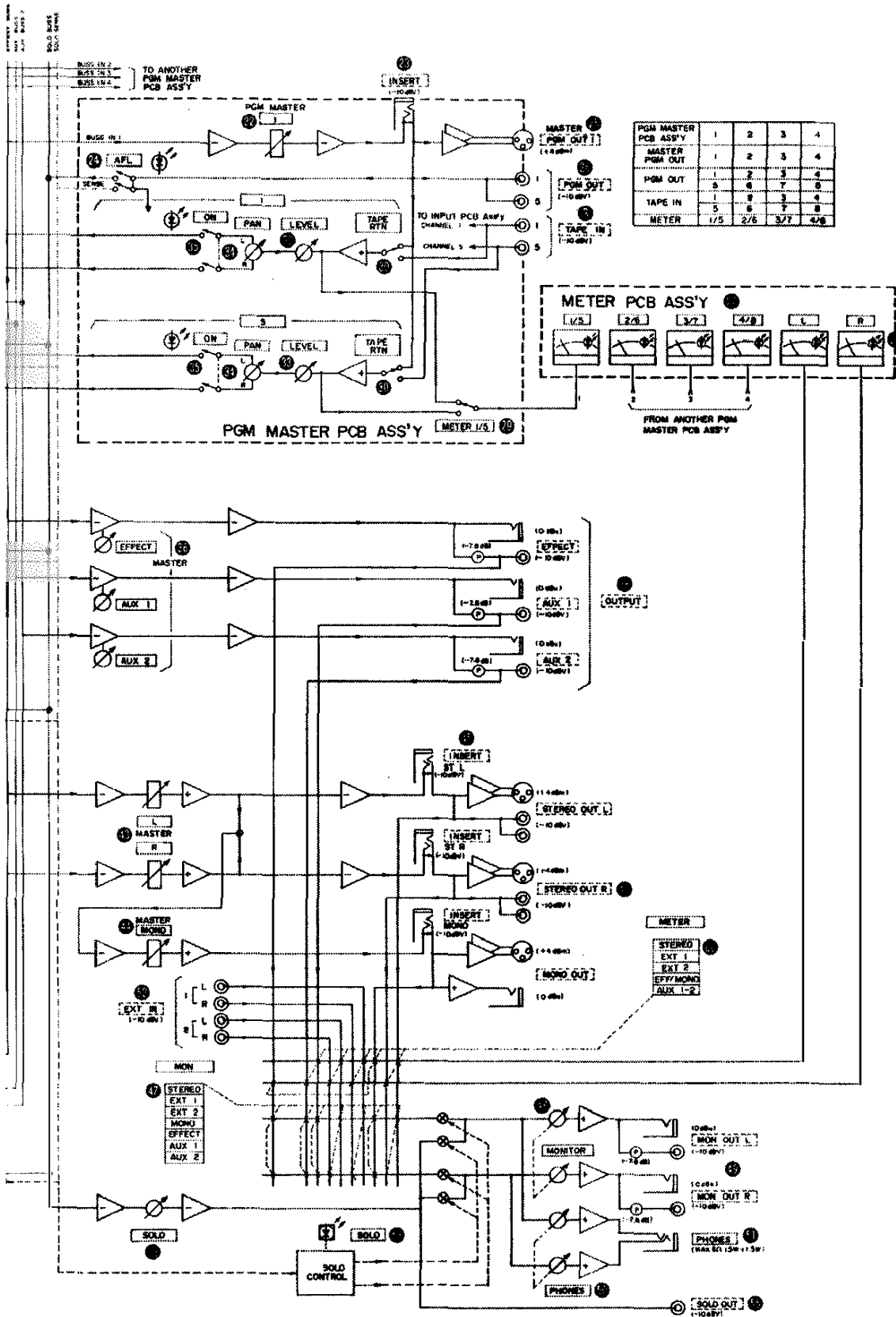

PGM MASTER PCB ASS'Y	1	2	3	4
MASTER PGM OUT	1	2	3	4
PGM OUT	5	6	7	8
TAPE IN	1	2	3	4
METER	5	6	7	8

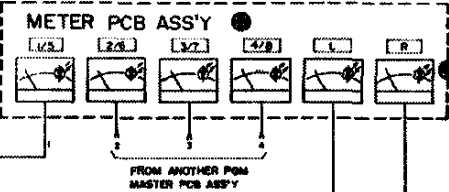

M-312/M-320 BLOCK DIAGRAM

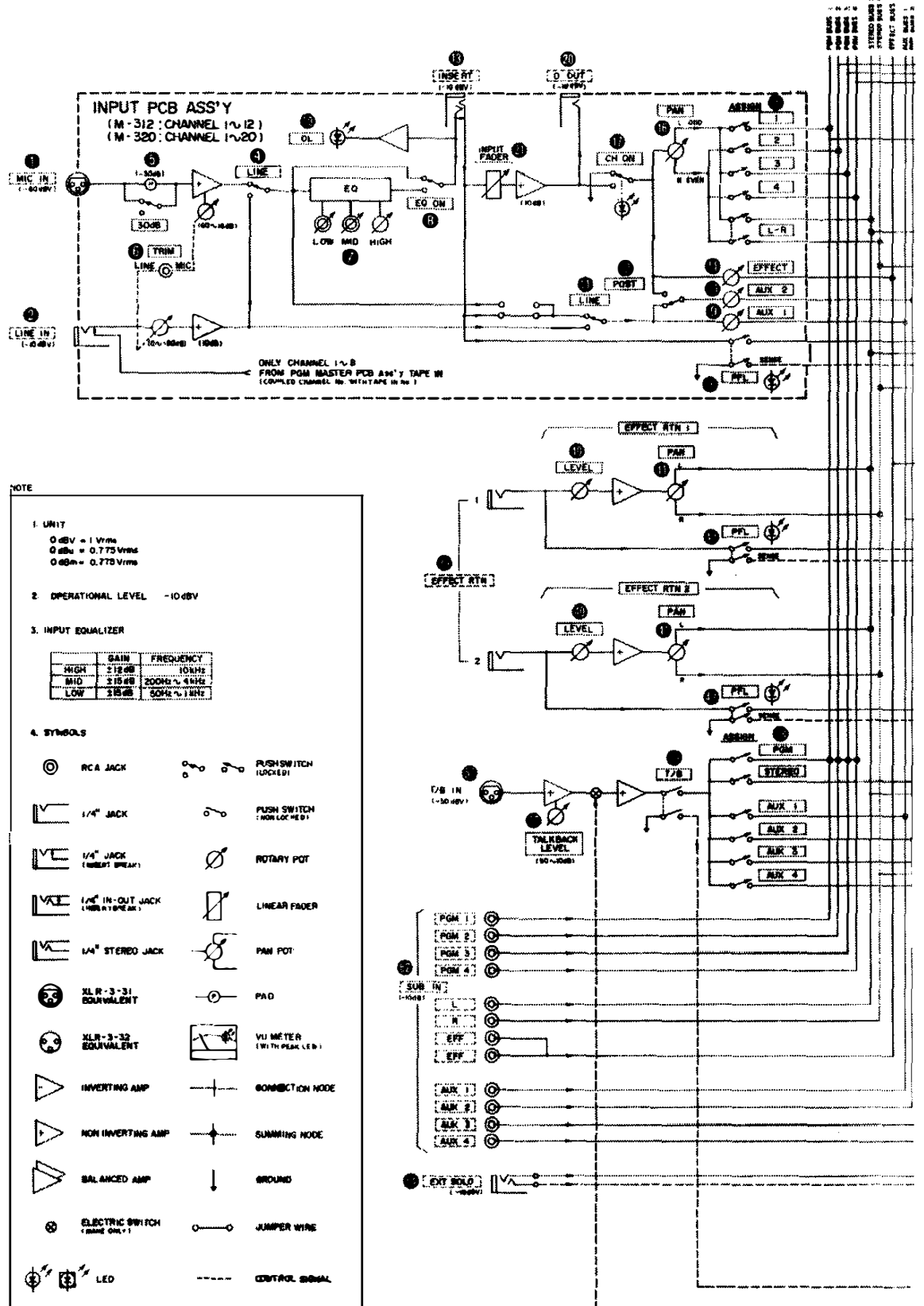

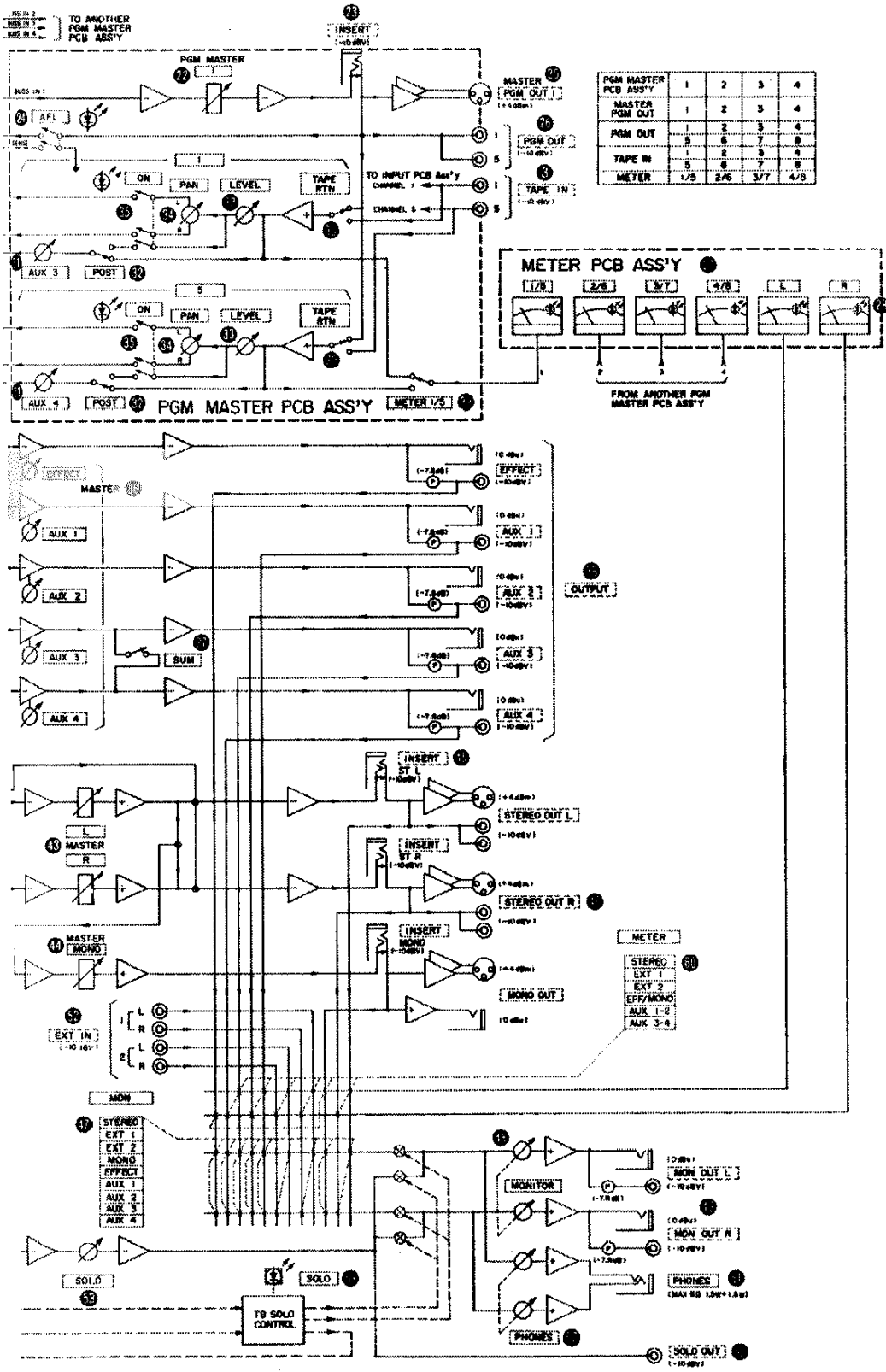

PGM MASTER PCB ASS'Y	1	2	3	4
MASTER PGM OUT	1	2	3	4
PGM OUT	5	6	7	8
TAPE IN	1	2	3	4
METER	1/5	2/6	3/7	4/8

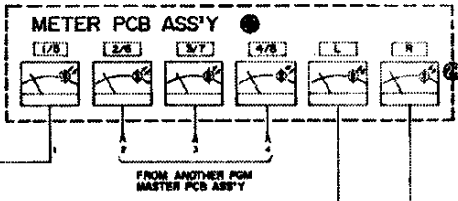

FROM ANOTHER PGM MASTER PCB ASS'Y

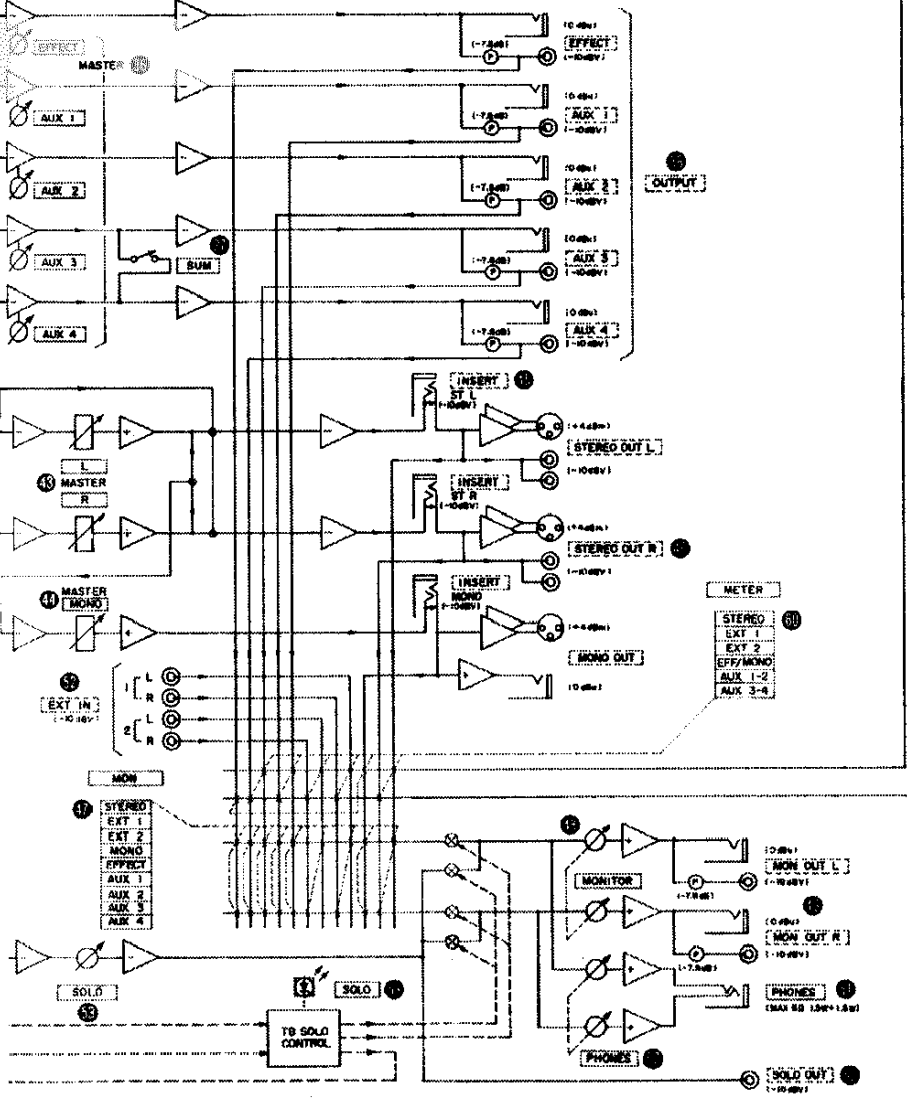

M-312/M-320 BLOCK DIAGRAM

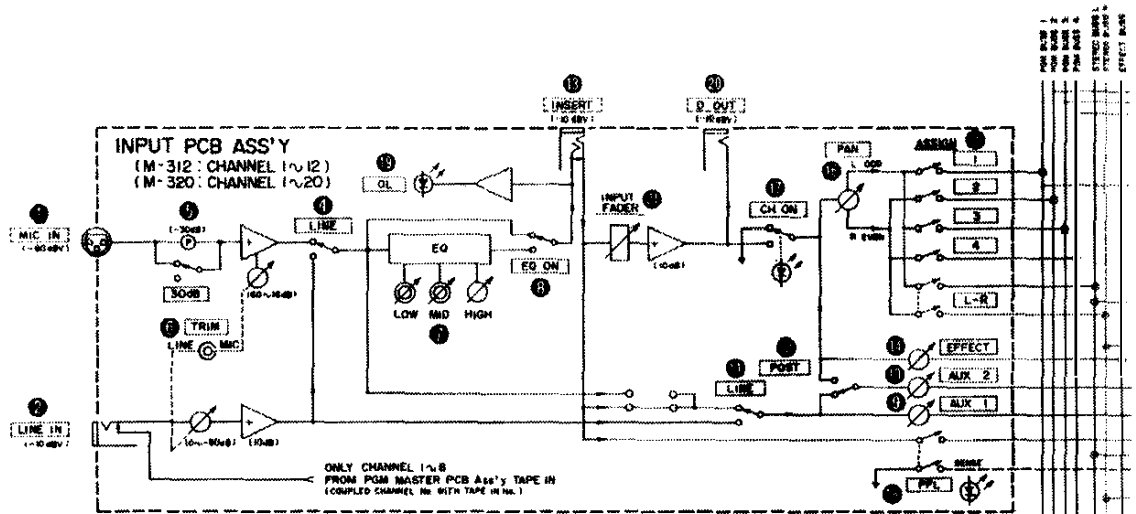

NOTE

- 1 UNIT
 0 dBV = 1 Vrms
 0 dBu = 0.775 Vrms
 0 dBm = 0.775 Vrms

2. OPERATIONAL LEVEL -10dBV

3. INPUT EQUALIZER

	GAIN	FREQUENCY
HIGH	±12dB	10kHz
MID	±15dB	200Hz ~ 4kHz
LOW	±15dB	50Hz ~ 1kHz

4. SYMBOLS

- | | | | |
|--|----------------------------------|--|--------------------------|
| | RCA JACK | | PUSH SWITCH (LOCKED) |
| | 1/4" JACK | | PUSH SWITCH (NOT LOCKED) |
| | 1/4" JACK (WHEATSTONE) | | ROTARY POT |
| | 1/4" IN-OUT JACK (100% AT BREAK) | | LINEAR FADER |
| | 1/4" STEREO JACK | | PAN POT |
| | XLR-3-51 EQUIVALENT | | PAD |
| | XLR-3-52 EQUIVALENT | | VU-METER (WITH PEAK LED) |
| | INVERTING AMP | | CONNECTION NODE |
| | NON-INVERTING AMP | | SUMMING NODE |
| | BALANCED AMP | | GROUND |
| | ELECTRIC SWITCH (MOM. ONLY) | | JUMPER WIRE |
| | LED | | CONTROL SIGNAL |

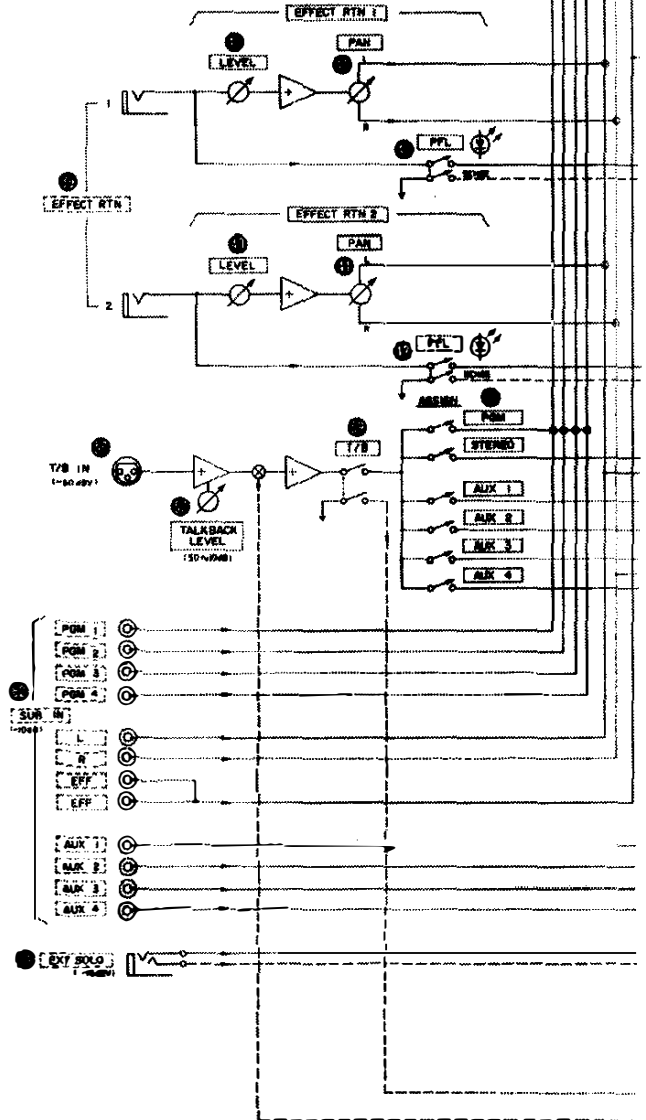

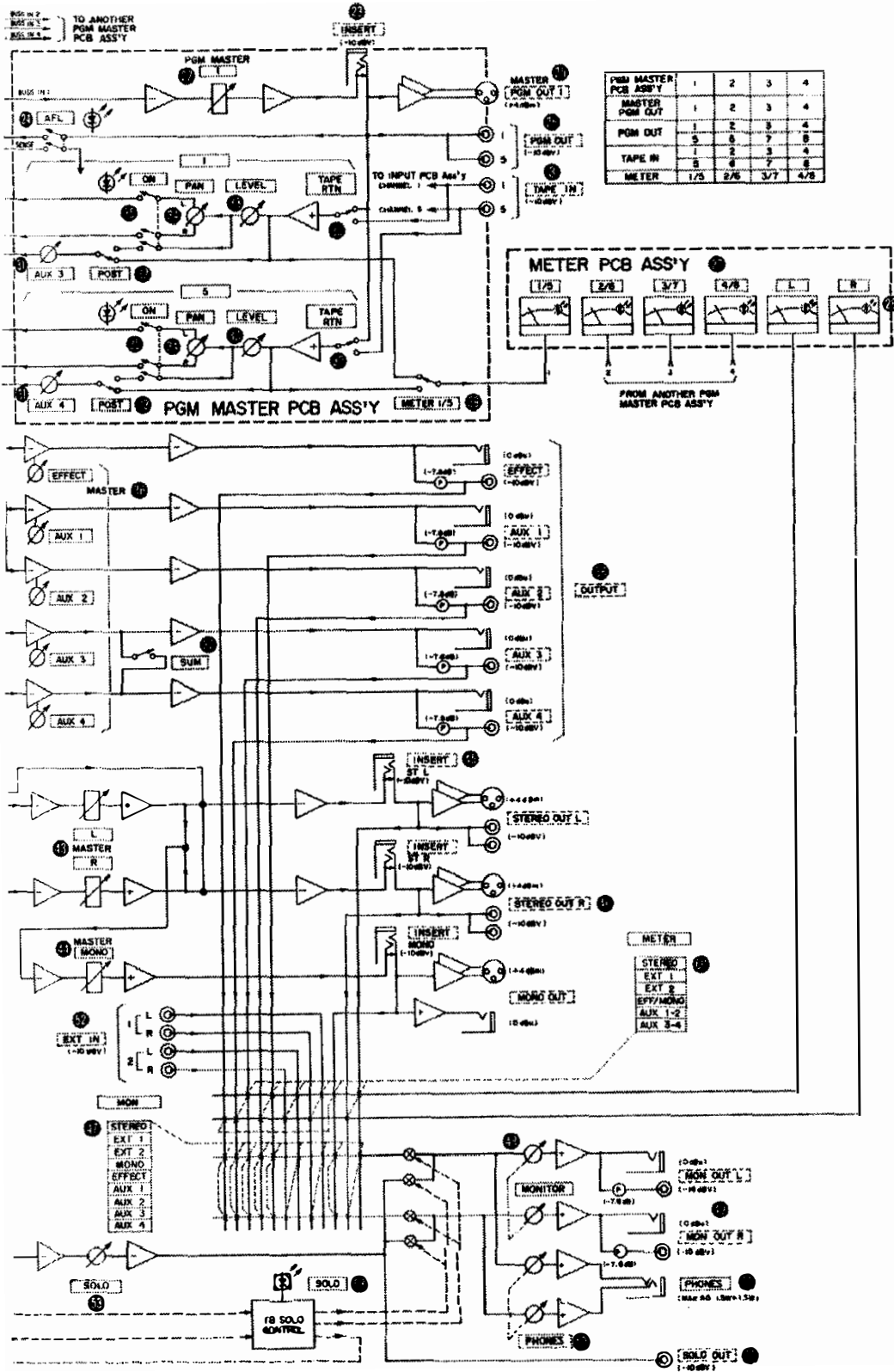

M-308 LEVEL DIAGRAMS

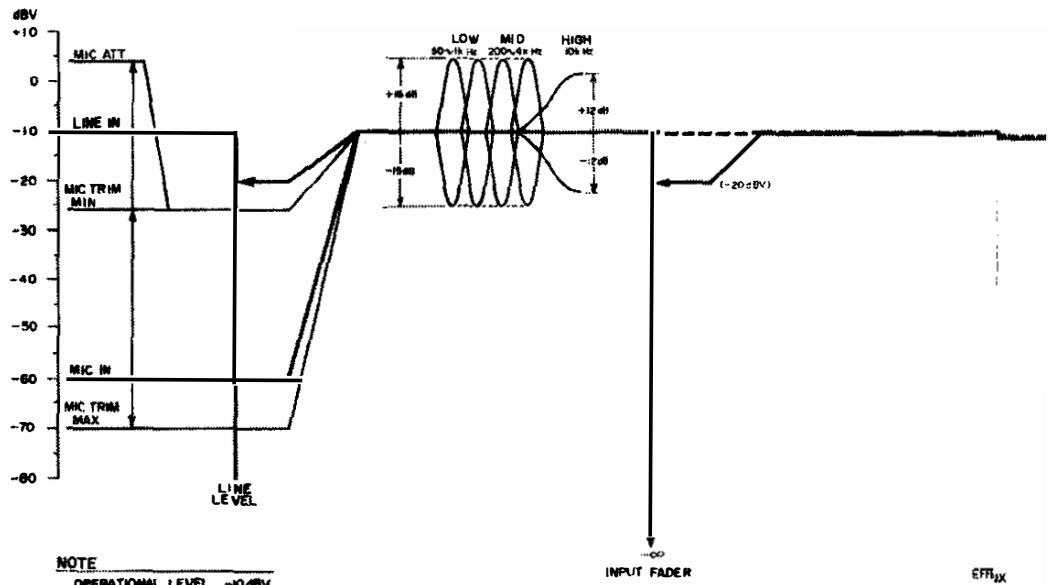
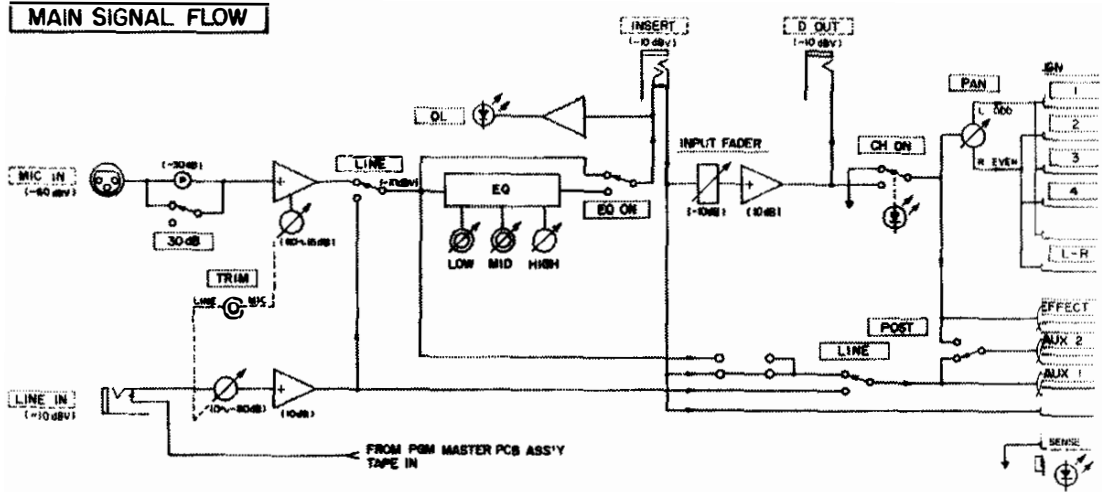

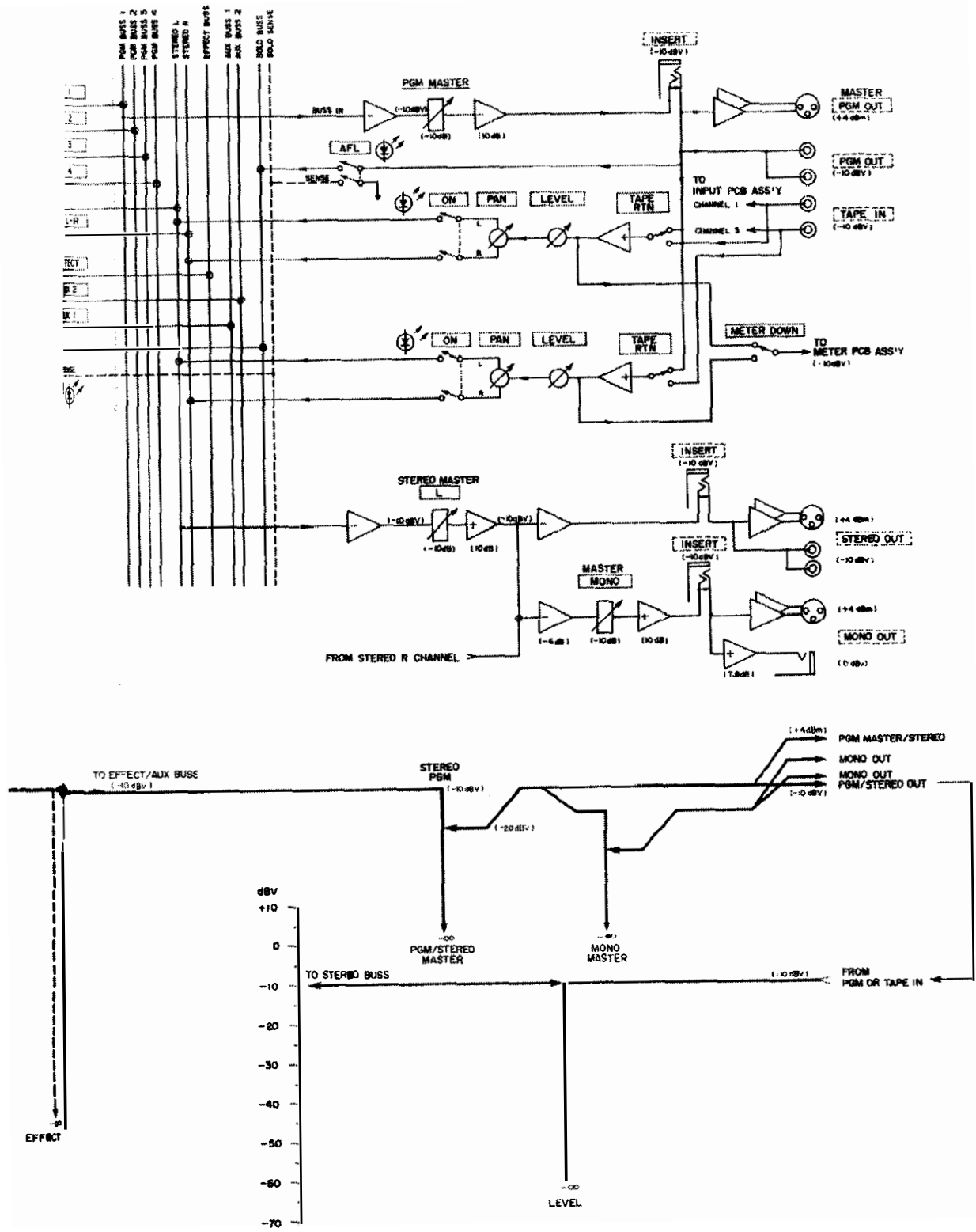

EFFECT RTN / MONITOR SIGNAL FLOW

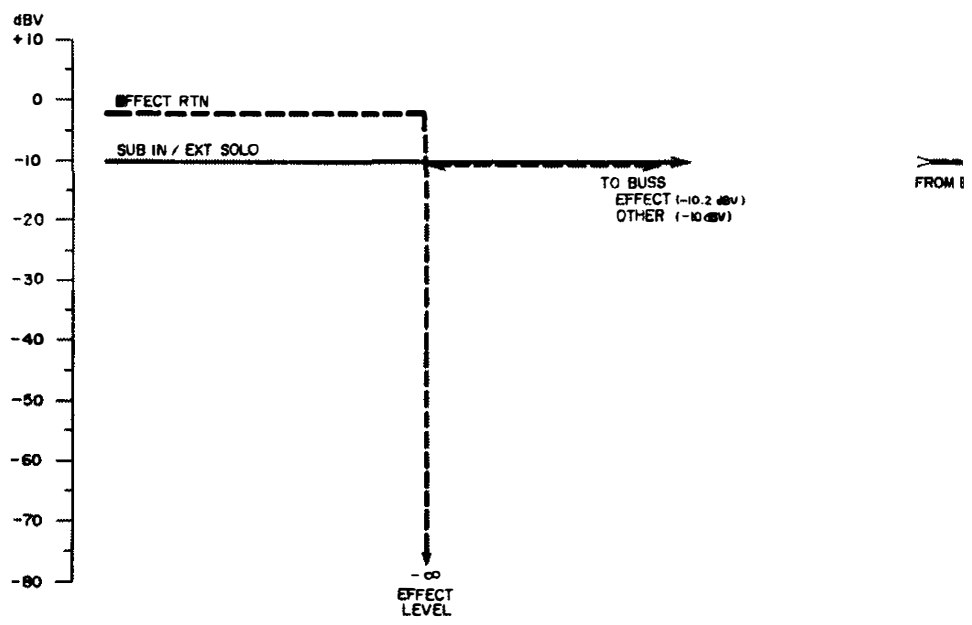
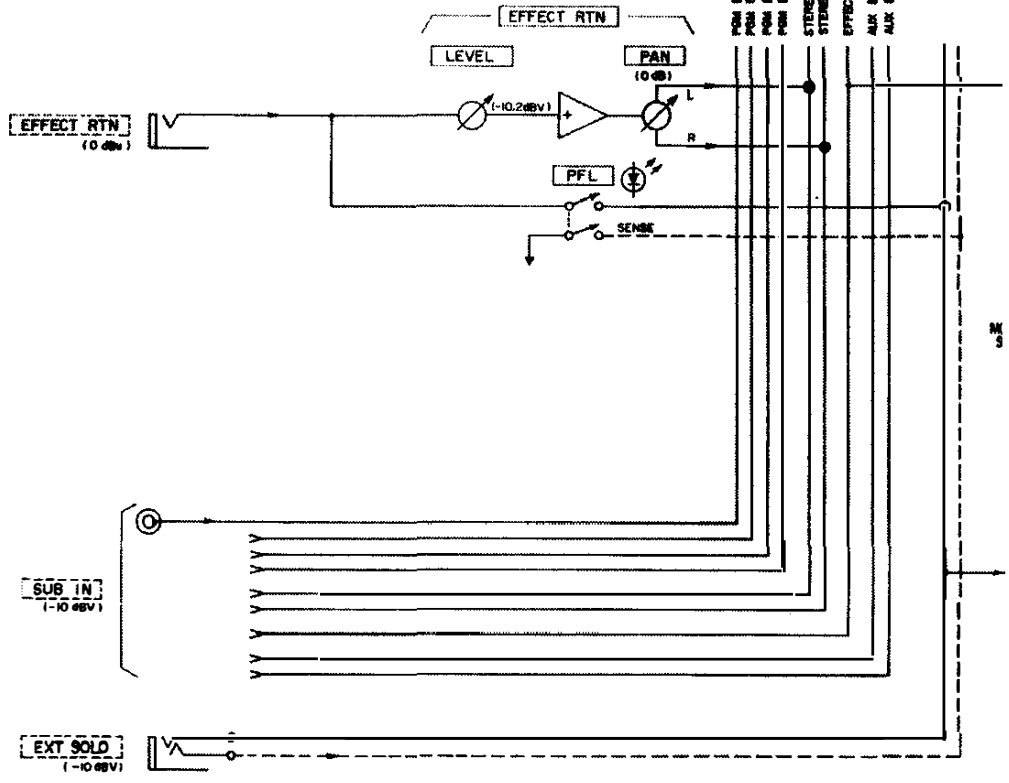

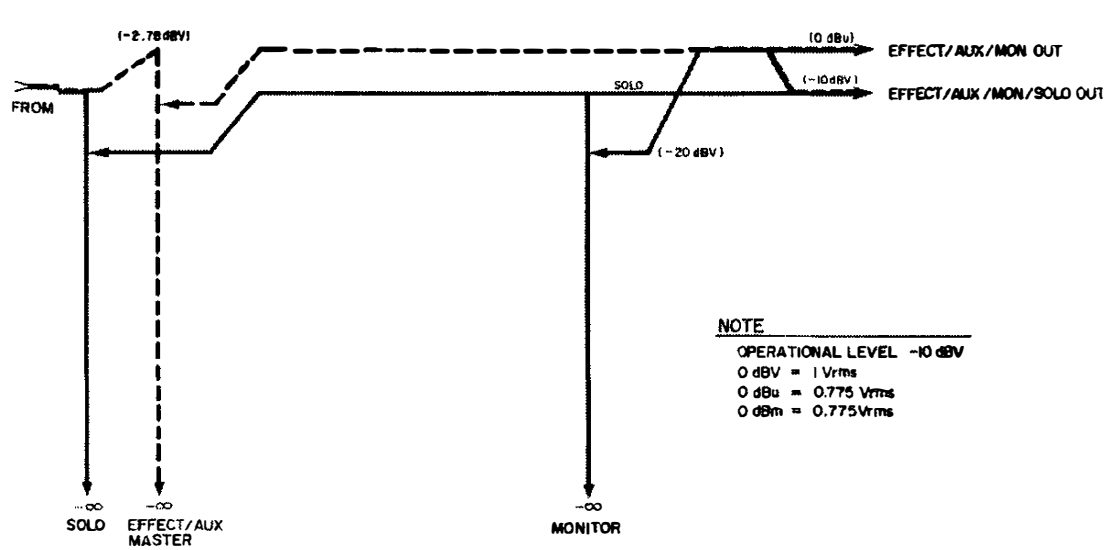
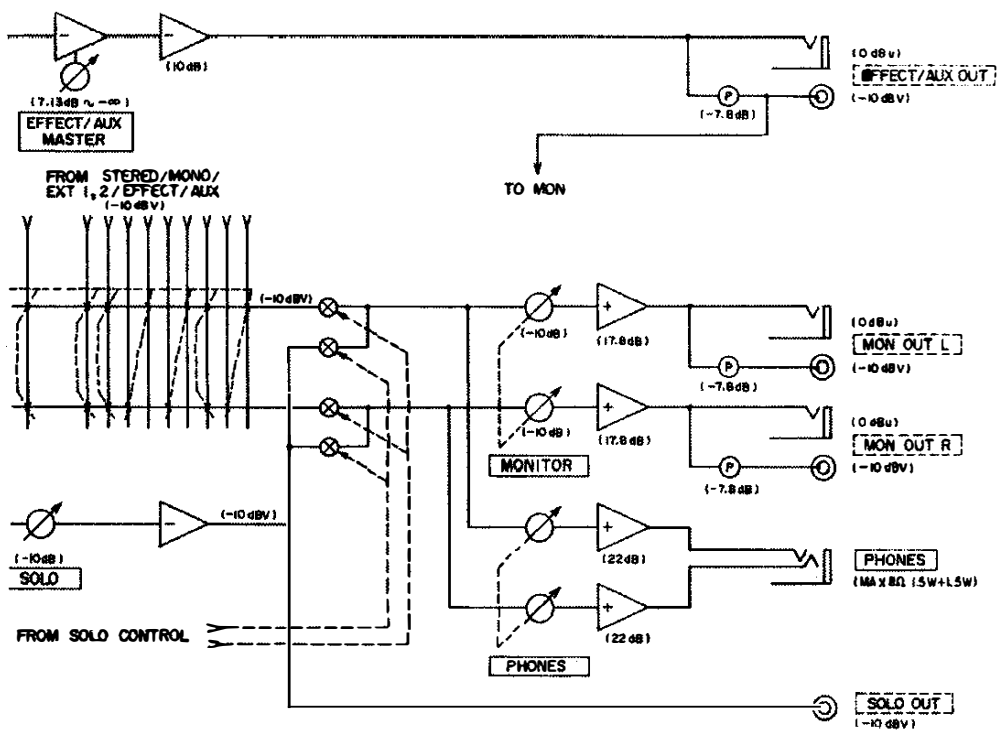

M-312/M-320 LEVEL DIAGRAMS

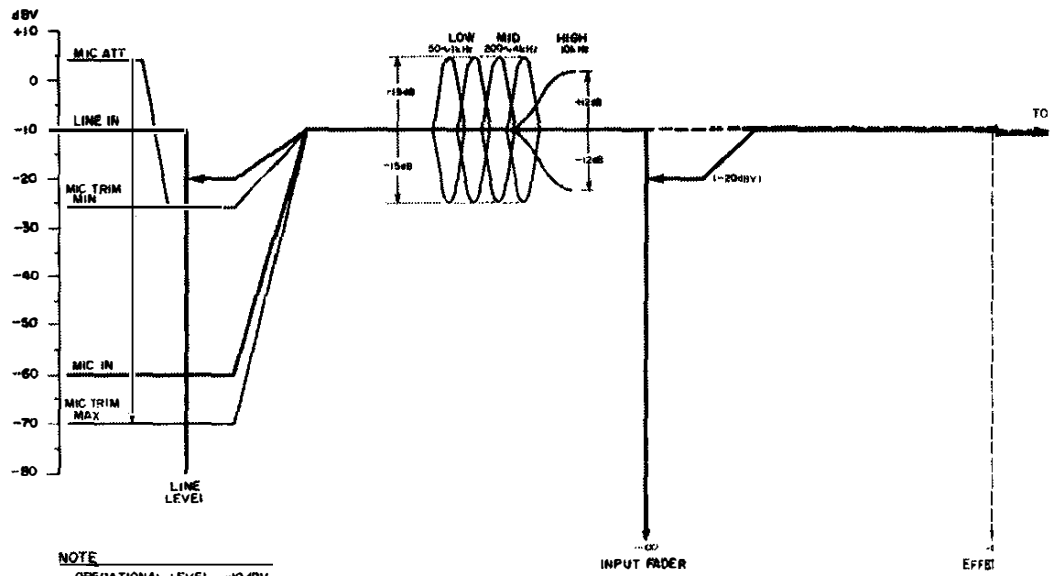
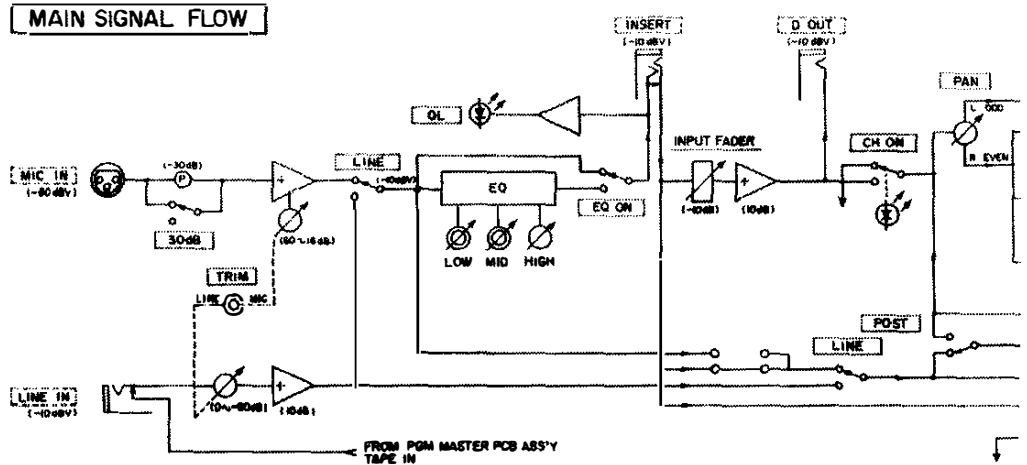

NOTE
 OPERATIONAL LEVEL: -10dBV
 0 dBV = 1 Vrms
 0 dBu = 0.775 Vrms
 0 dBm = 0.775 Vrms

EFFECT RTN / MONITOR SIGNAL FLOW

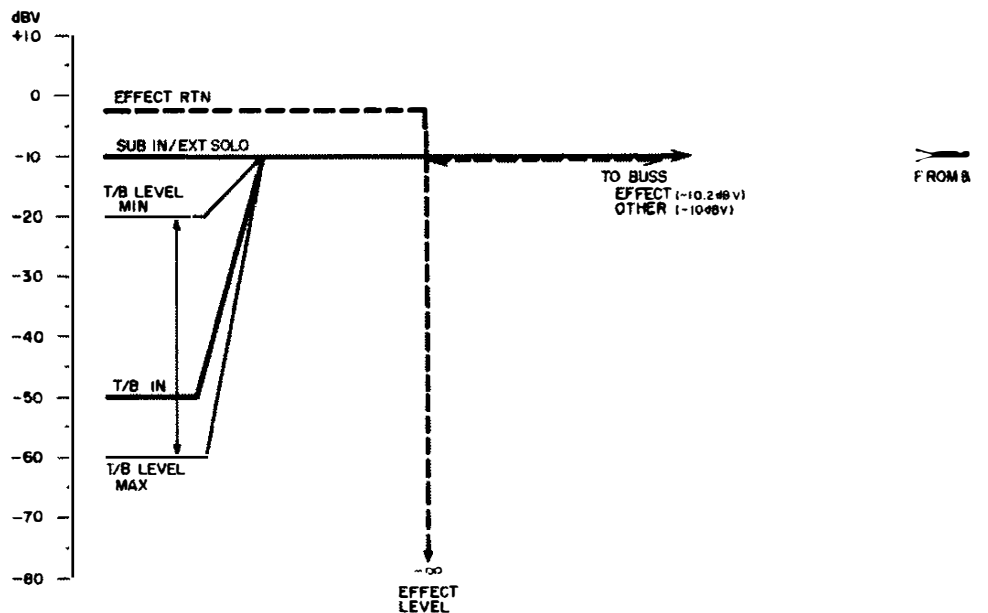
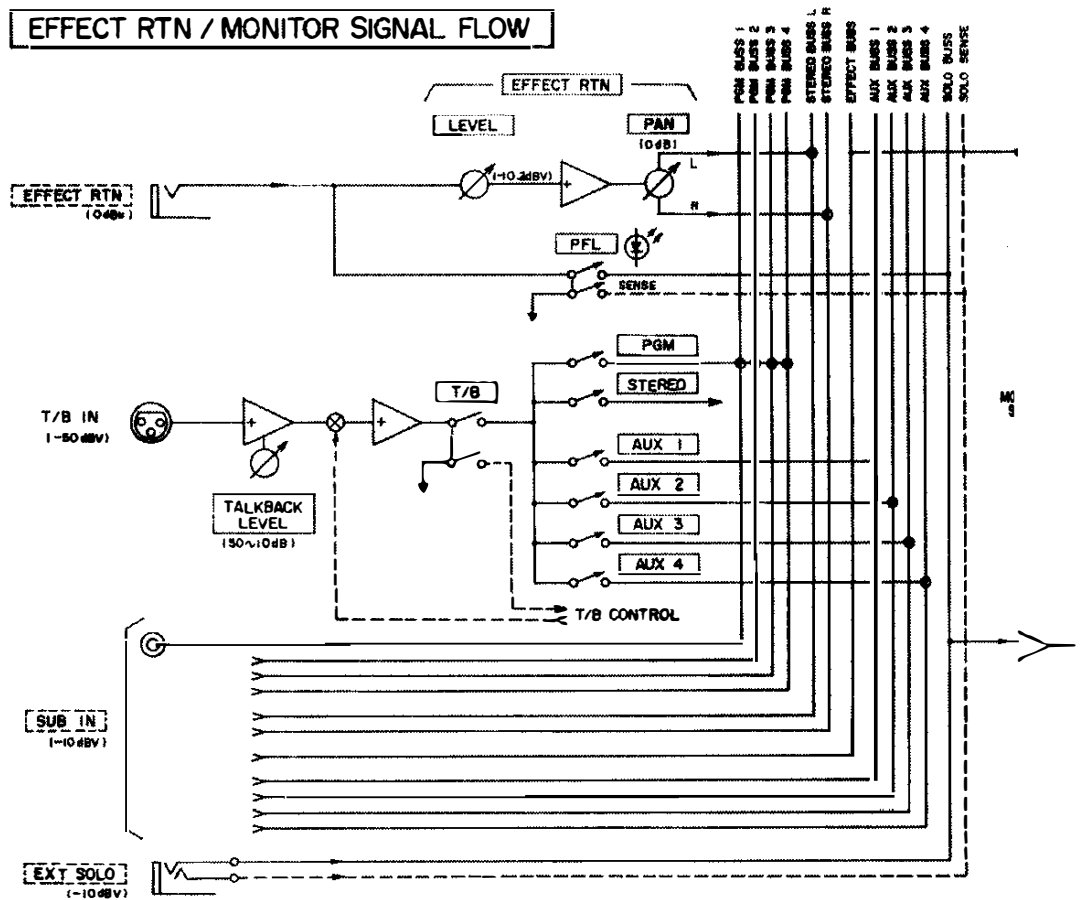

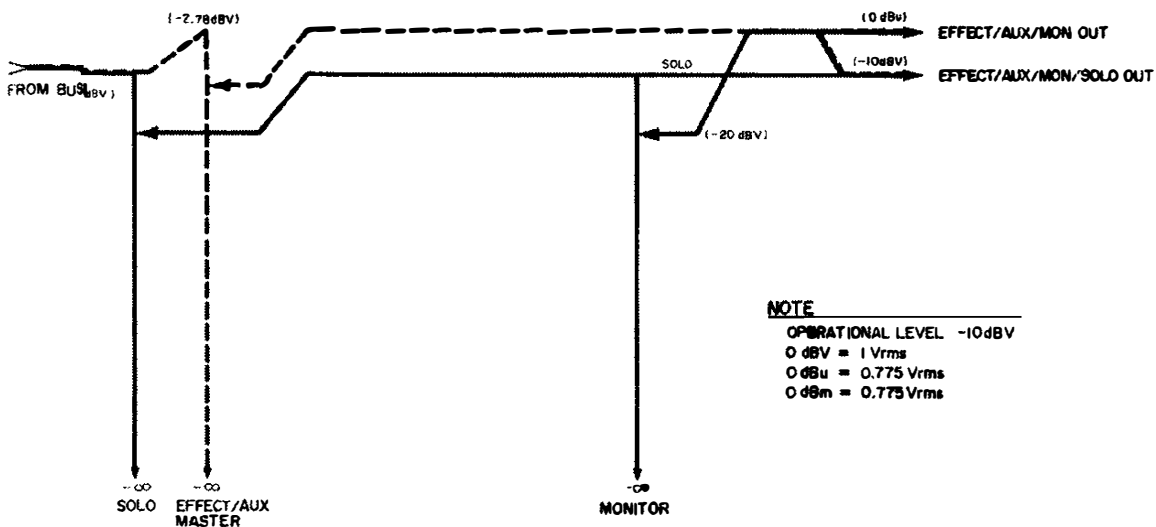
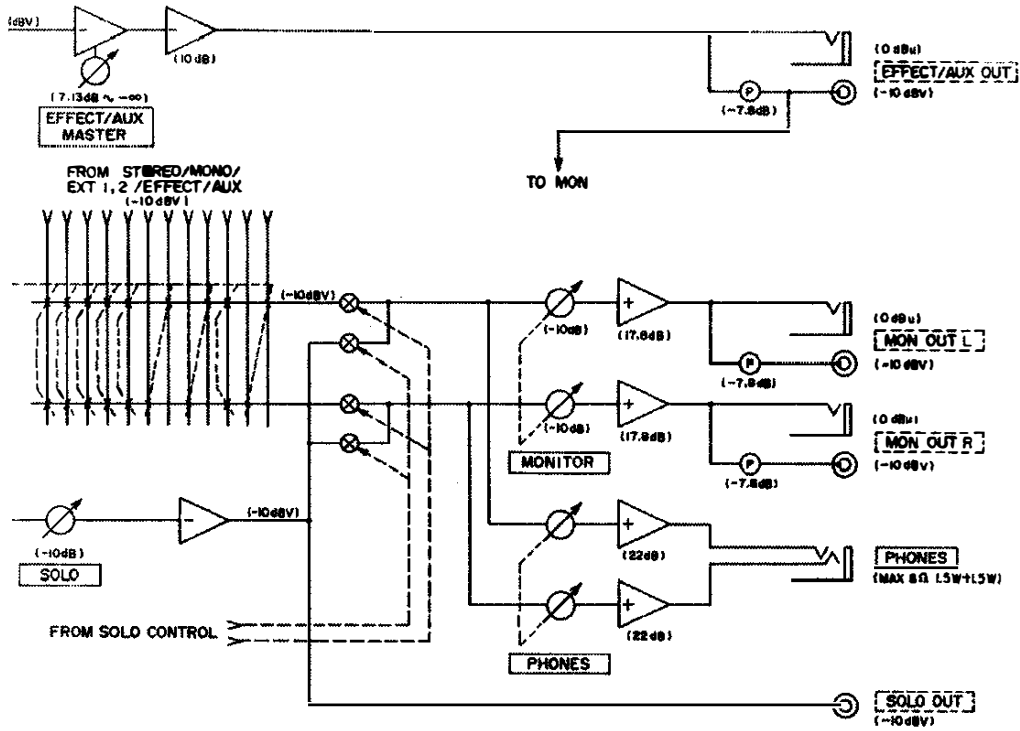

NOTE
 OPERATIONAL LEVEL -10dBV
 0 dBV = 1 Vrms
 0 dBu = 0.775 Vrms
 0 dBm = 0.775 Vrms

MAINTENANCE

1. LEVEL SETTING AND OPERATION CHECK

“0 dB” reference voltages:

0 dBV is referenced to 1 Vrms.

0 dBm/0 dBu is referenced to 0.775 Vrms.

1-1. MASTER FADERS AND POTS

Connect a -10 dBV, 1 kHz signal to the input jacks listed in the table, and by adjusting the MASTER faders and MASTER pots of the channels being checked, confirm that the relative outputs provide nominal output level signals.

Input Jacks		Controls	Output Jacks	Output Nominal Levels
SUB IN	PGM 1 PGM 2 PGM 3 PGM 4	PGM Master Faders between 7-8 on the scale	PGM OUT 1 PGM OUT 2 PGM OUT 3 PGM OUT 4	+4 dBm at XLR connectors -10 dBV at RCA phono jacks
	L	Stereo Master Fader L between 7-8 on the scale	STEREO OUT L	+4 dBm at XLR connectors -10 dBV at RCA phono jacks (stereo) 0 dBu at 1/4" phone jack (mono)
	R	Stereo Master Fader R between 7-8 on the scale	STEREO OUT R	
	L and R	MONO Master Fader between 7-8 on the scale	MONO OUT	
	EFF	EFFECT Master Pot	EFFECT OUTPUT	0 dBu at 1/4" phone jacks -10 dBV at RCA phono jacks
	AUX 1	AUX 1 Master Pot	AUX 1 OUTPUT	
	AUX 2	AUX 2 Master Pot	AUX 2 OUTPUT	
	AUX 3*	AUX 3 Master Pot	AUX 3 OUTPUT	
AUX 4*	AUX 4 Master Pot	AUX 4 OUTPUT		
EXT SOLO	SOLO level pot	SOLO OUT	-10 dBV	
EXT IN 1 (L & R) EXT IN 2 (L & R)	EXT 1 and EXT 2 in the MONitor select switch rack MONITOR level pot	MON OUT L & R	0 dBu 1/4" phone jacks -10 dBV at RCA phono jacks	
	PHONES level pot	Headphone output (8 ohm impedance)	Max. level 1.5 W + 1.5 W	

* M-312/M-320 only.

1-2. VU METERS

Check that the VU meters indicate “0 VU” when PGM OUT (1-4) and STEREO OUT (L & R) provide the nominal level readings. If the meters do not indicate “0 VU”, adjust VRs with a slot blade screwdriver inserted into an access hole located above each meter.

1-3. PEAK LEDS

Peak LEDs are preset to light at +11 VU and extinguish at +8.5 VU.

Increase the input level by 11 dB from -10 dBV to +1 dBV without altering the settings in paragraph 1-1 and check to see that the peak LEDs light at a +11 VU reading.

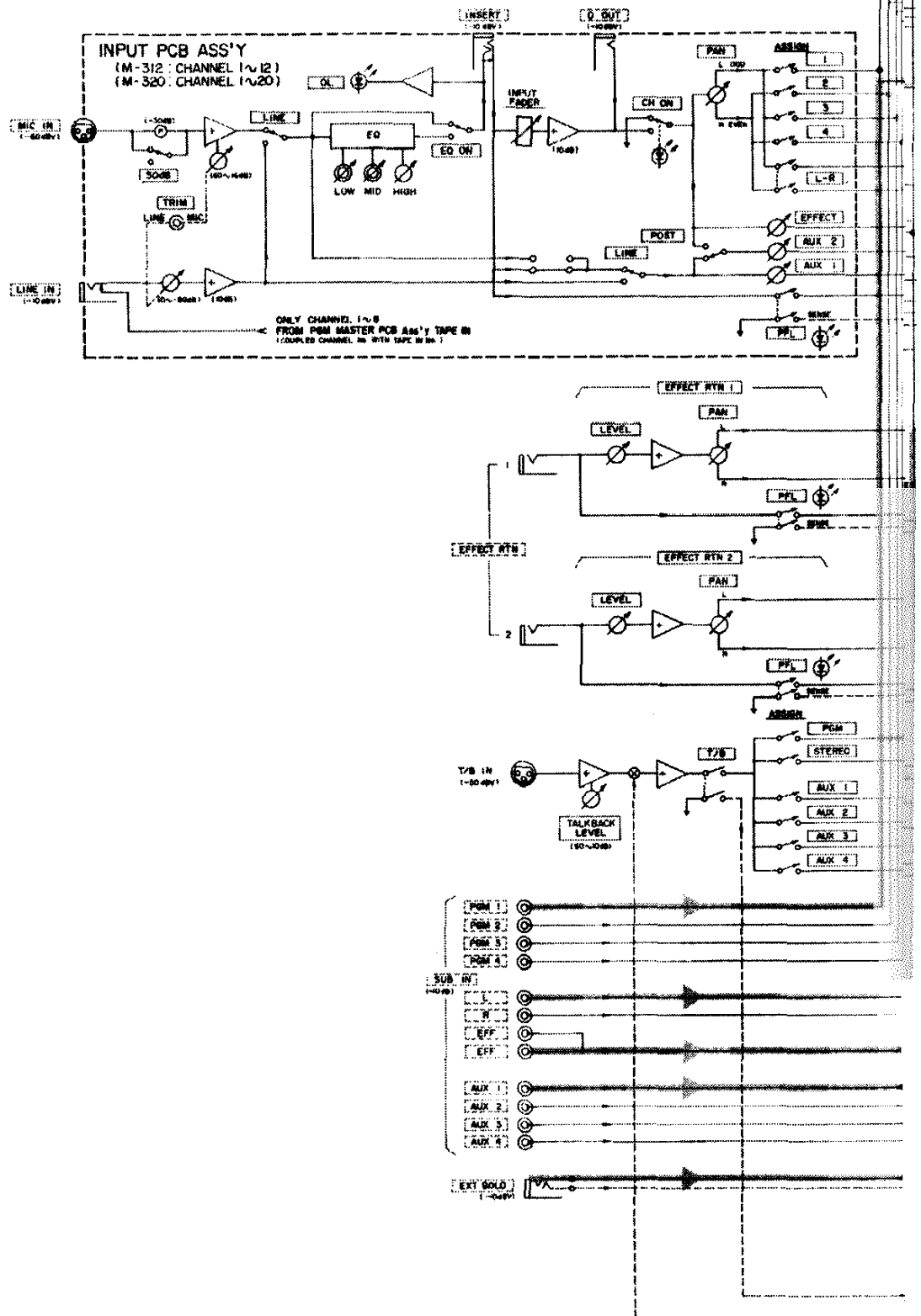

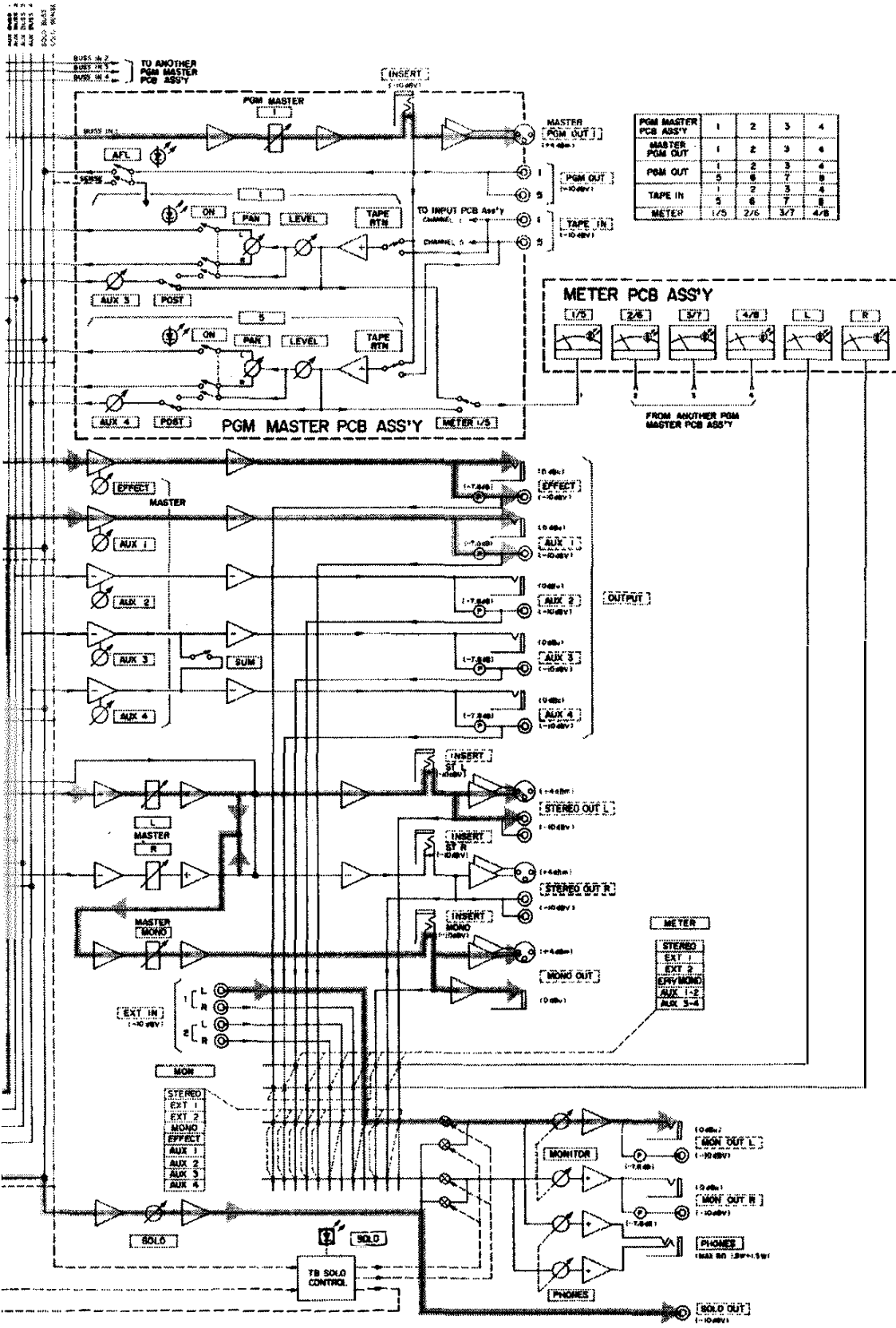

PGM MASTER PCB ASS'Y	1	2	3	4
MASTER PGM OUT	1	2	3	4
PGM OUT	5	6	7	8
TAPE IN	9	8	7	6
METER	1/5	2/6	3/7	4/8

METER	STEREO
EXT 1	
EXT 2	
EXT MONO	
AUX 1-2	
AUX 3-4	

1-4. CHANNEL FADERS AND POTS

Input Channel Sections of the 300 Series Mixers are all identical. TAPE INs 1-8 are internally connected to LINE INs 1-8 and disconnected when 1/4" phone plugs are inserted to LINE INs.

1) Channel Faders (INSERT → D.OUT)

Connect a -10 dBV, 1 kHz signal to the channel INSERT jacks and set the channel faders for a -10 dBV reading at D.OUT. Confirm that setting of the faders to the shaded area (between 7-8 on the scale) provides a -10 dBV output.

2) TRIM-LINE Port (LINE IN → D.OUT)

Connect a -10 dBV, 1 kHz signal to LINE IN. Press the LINE switch to select the LINE IN signal. Adjust the TRIM-LINE pot for a -10 dBV reading at D.OUT.

3) Equalizer (LINE IN → D.OUT)

Connect a -10 dBV, 1 kHz signal to LINE IN and press the EQ ON switch. Read the levels at D.OUT while turning the GAIN knobs of the three sections (HIGH, MID and LOW). If the readings vary approx. ±15 dB in regard to a -10 dBV nominal level, the EQ electronics are considered normal.

4) AUX 1 and AUX 2 Level Pots (LINE IN → AUX 1, AUX 2 OUTPUTS)

Connect a -10 dBV, 1 kHz signal to LINE IN and press the AUX 1 LINE switch. Confirm that AUX 1, 2 OUTPUTS provide nominal levels (0 dBu at 1/4" phone jacks, -10 dBV at RCA phono jacks) when the AUX 1, 2 level pots are set to the max. position or fully right.

5) EFFECT Send Control (LINE IN → EFFECT OUTPUT)

Connect a -10 dBV, 1 kHz signal to the LINE IN jacks and press the channel ON switches. Confirm that setting of the EFFECT send control to maximum provides nominal levels to the EFFECT OUTPUT (0 dBu at 1/4" phone jacks, -10 dBV at RCA jacks).

6) TRIM-MIC Pot (MIC IN → D.OUT)

Disengage the LINE switch to select the MIC IN signal. Connect a -60 dBV, 1 kHz signal to MIC IN and adjust the TRIM-MIC pot for a -10 dBV reading at D.OUT (TRIM-MIC control range is 45 dB approx.).

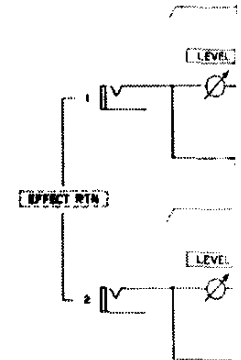
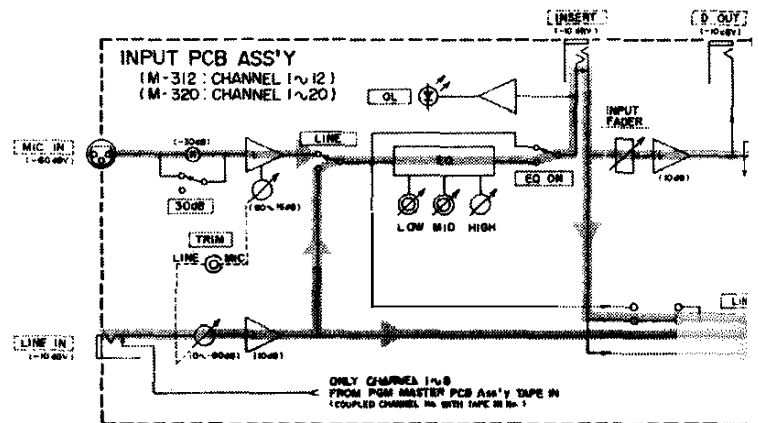
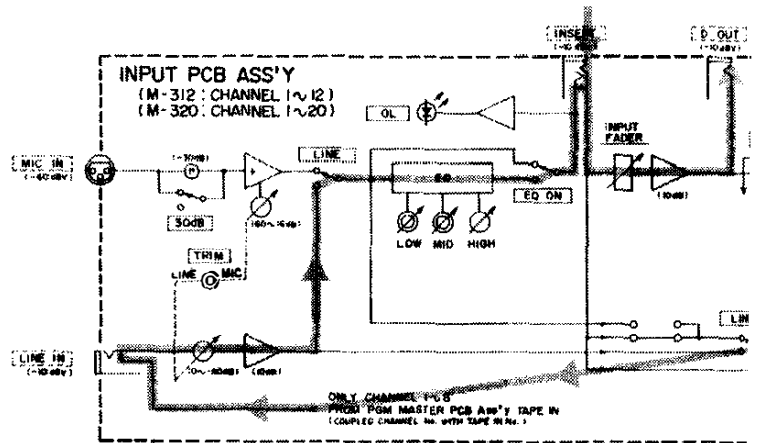

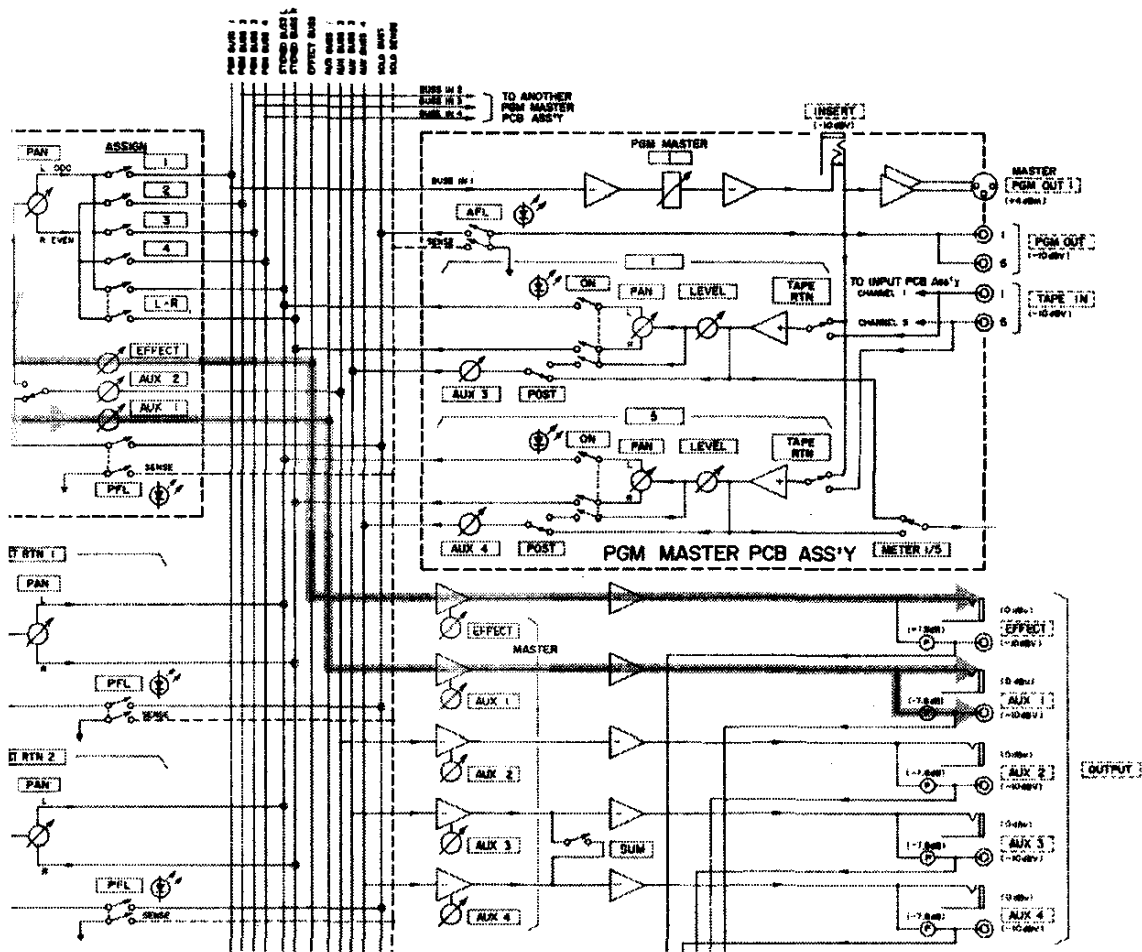
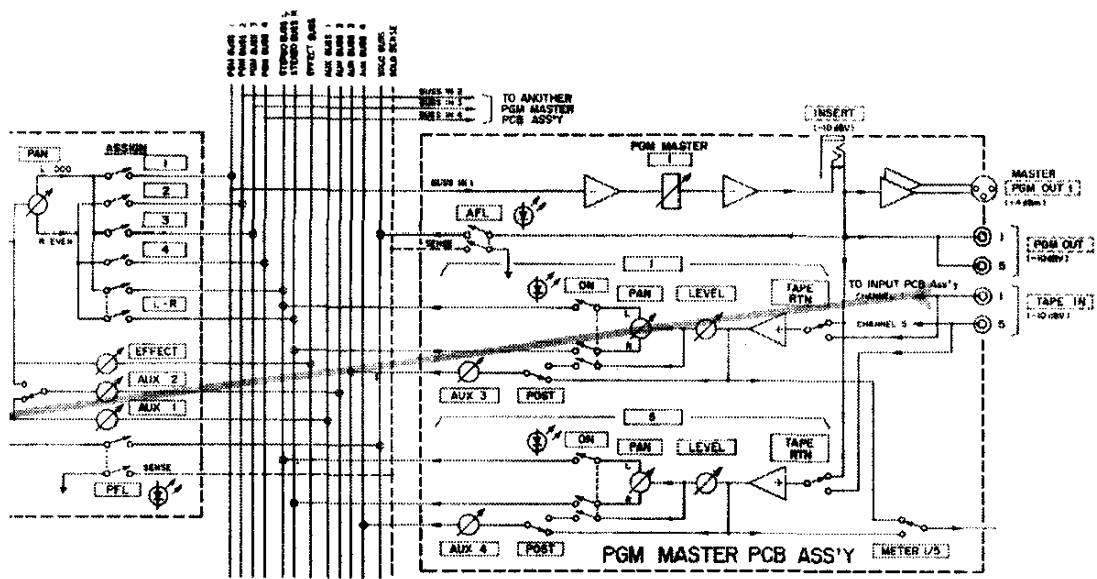

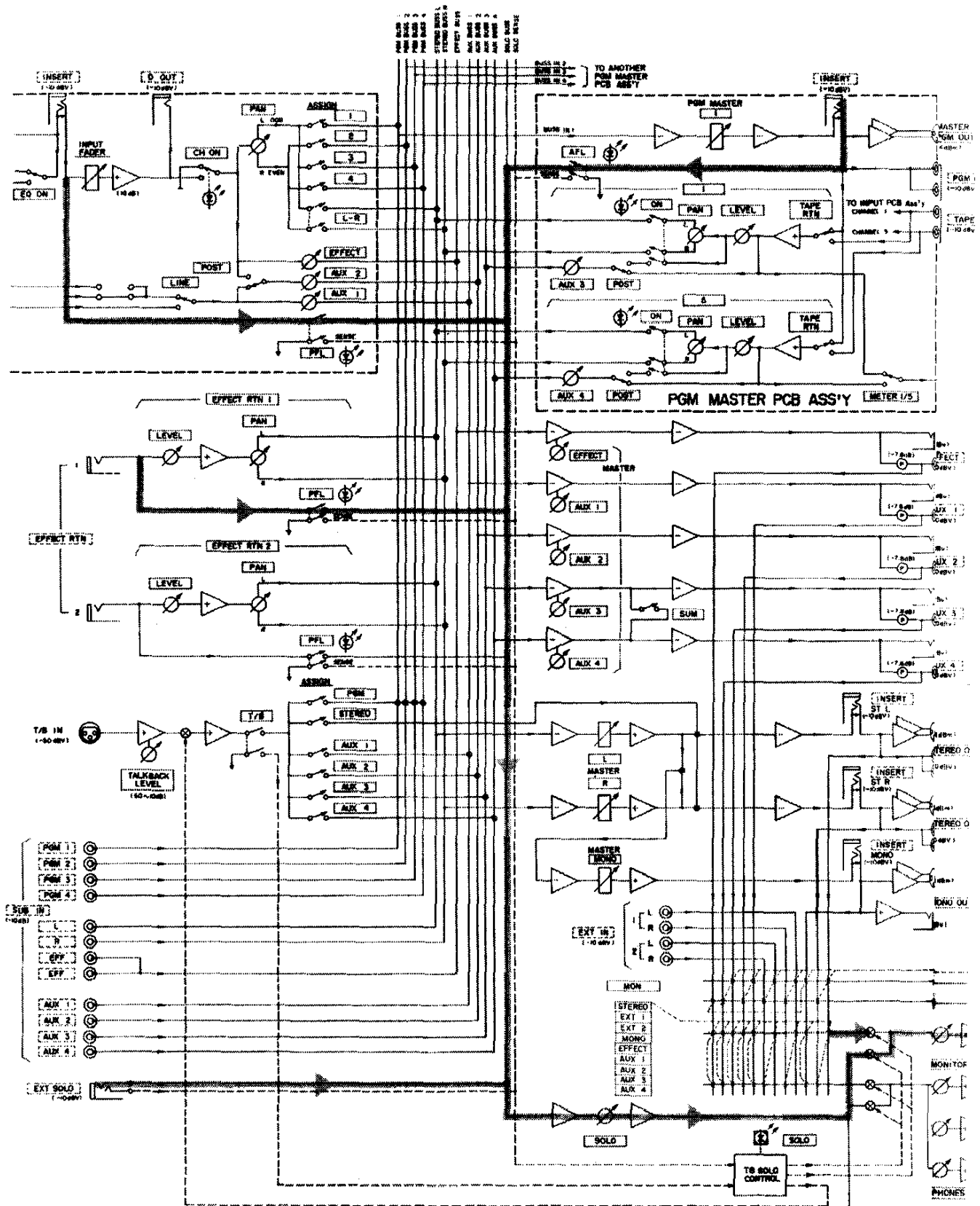

7) Mic Pad (30 dB)

With TRIM-MIC set as in paragraph 1-4. 6), press the mic pad switch, labeled 30 dB. Increase the input level by 30 dB to compensate the inserted 30 dB pad. Confirm that the output level at D.OUT is -10 dBV ±2 dB. After checking, reset the input level to nominal -60 dBV and the mic pad switch to the "off" position.

**8) OL (OverLoad) Indicator
(MIC IN → INSERT Send Contact)**

With TRIM-MIC set as in paragraph 1-4. 6), increase the MIC IN level and confirm that the OL indicator turns on at +17 dBV at the INSERT Send Contact and turns off at +13 dBV.

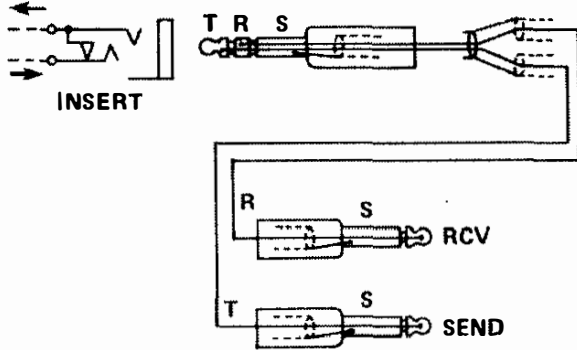

- T – Tip, send signal
- R – Ring, receive signal
- S – Sleeve, ground

**9) Channel Assign Switches and PAN Controls
(MIC IN → PGM OUT 1-4, STEREO OUTPUT L & R)**

Checking the PGM OUTs (1-4) and STEREO OUTPUTs (L & R) should be performed with the MIC IN circuits set as in paragraph 1-4. 6). Confirm that nominal output levels are obtained

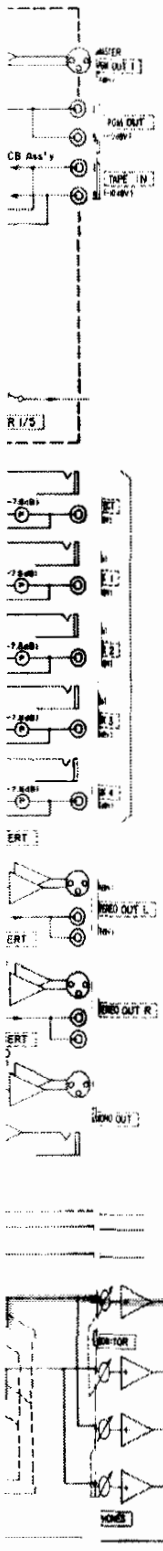

(+4 dBm at XLR connectors, -10 dBV at RCA phono jacks) when PAN is turned fully left (assignment to ODD PGM/STEREO L busses) and fully right (assignment to EVEN PGM/STEREO R busses). Also, confirm that the readings decrease 1.5 – 3.5 dB from nominal level when PAN is set to the center position.

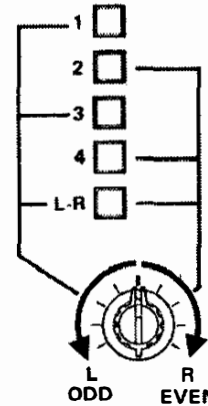

1-5. MON(itor) OUT L & R

With the output level at STEREO OUT L & R, EXT IN 1 & 2, MONO OUT, EFFECT OUTPUT, AUX OUTPUT 1 – 4 (AUX 3, 4 on 312 and 320 only) set as in paragraph 1-1, confirm that each of those output signals appears at the MON OUT jacks when the relative MON select switches are pressed. Use the MONITOR level control for a 0 dBu reading at 1/4" phone jacks and -10 dBV at RCA phono jacks. When the PFL and AFL switches are depressed, the monitor signals above are interrupted and the channel signal and the PGM signal, respectively, are sent to the MON OUT jacks passing through the SOLO level control.

Switches	Indicators	Monitor Sources
PFL	PFL LED lights red. SOLO LED lights red.	Pre input-fader EFFECT RTN input EXT SOLO input
AFL	AFL LED lights red. SOLO LED lights red.	PGM OUT 1-4

Confirm that all the monitor signals are interrupted when the T/B (TalkBack) switch on M-312/M320 is depressed.

1-6. EFFECT RTN SYSTEM
(EFFECT RTN → STEREO OUT L & R)
(EFFECT RTN → MON OUT L & R)

Connect a -10 dBV, 1 kHz signal to the EFFECT RTN 1/4" phone jacks. Turn the EFFECT RTN PAN fully left and, by adjusting the EFFECT RTN LEVEL control, check that nominal levels are obtainable at STEREO OUT L. Then, turn the PAN fully right and check the level at STEREO OUT R.

Note: Be careful not to reduce the input level too much because there is a low input impedance (3.5 kΩ).

PAN	STEREO OUT	
Set fully left	L	+4 dBm at XLR connectors
Set fully right	R	-10 dBV at RCA phono jacks

By pressing the PFL switch, the signal connected to the EFFECT RTN 1/4" jack is delivered to the MON OUT jacks. Refer to paragraph 1-5.

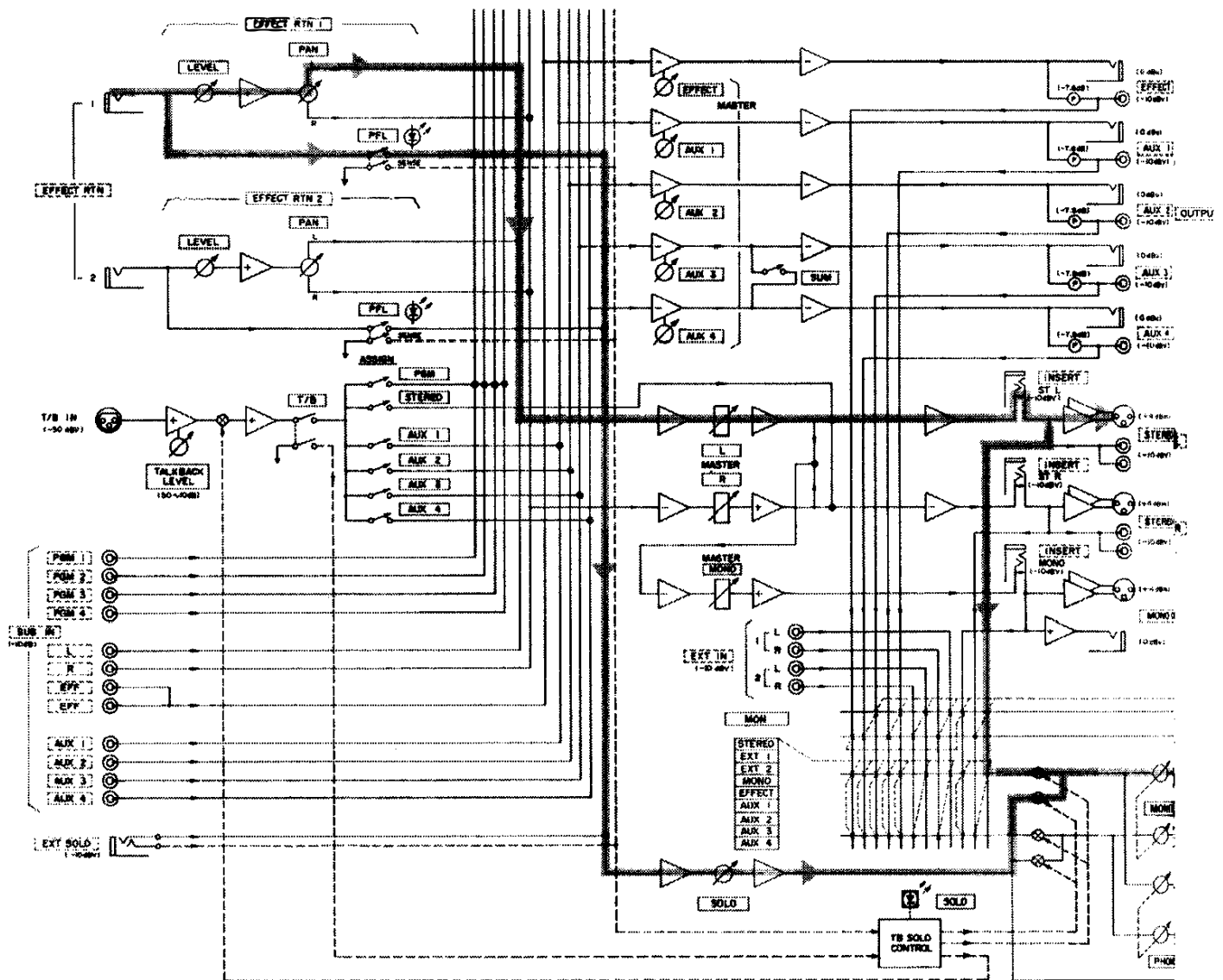

1.7. PGM OUT/TAPE RTN MONITOR SYSTEMS

1) PGM OUT Monitor System (PGM → STEREO OUT L & R)

With the level at the PGM OUT 1 – 4 jacks set to nominal level [see paragraph 1-4. 9)], press the monitor ON switch, situated in the TAPE RTN monitor control rack (green LED lights). By adjusting the TAPE RTN PAN and LEVEL pots (Stereo Master Faders should be in the shaded area as set in paragraph 1-1), confirm that the STEREO OUT jacks provide nominal levels indicated in the table in paragraph 1-6.

Monitor ON switches 1 and 5 select the PGM OUT 1, monitor ON switches 2 and 6 the PGM OUT 2, monitor ON switches 3 and 7 the PGM OUT 3, and monitor ON switches 4 and 8 the PGM OUT 4.

2) TAPE RTN Select Switch

Connect a -10 dBV, 1 kHz signal to the TAPE IN jacks and confirm that the STEREO OUT source switches from PGM OUT to TAPE IN when the TAPE RTN select switch is depressed.

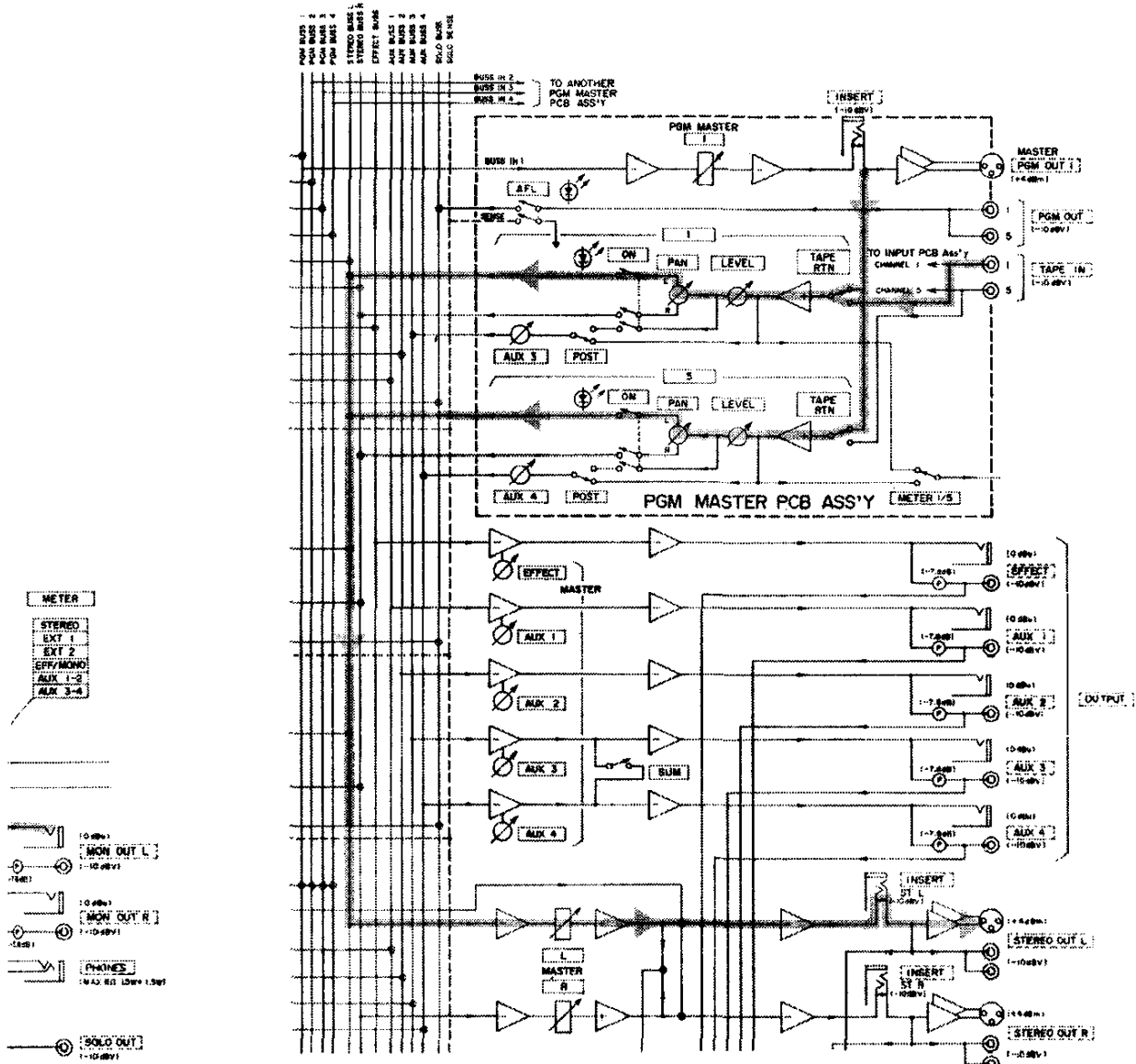

1-8. AUX 3, AUX 4 OUTPUTS (312 & 320 ONLY)

AUX 3 is accessed from TAPE INs 1 – 4 while AUX 4 derives signals from TAPE INs 5 – 8. Press the TAPE RTN select switches "1" – "4", set the respective AUX 3 send controls to max. and confirm that nominal level is obtainable at the AUX 3 OUTPUT.

Check also the signal path from TAPE INs 5 – 8 to the AUX 4 OUTPUT.

With the AUX 3 & 4 POST and monitor ON switches depressed, post signals are sent to the AUX 3 & 4 OUTPUTs.

With the AUX 3 & 4 SUM switches depressed,

the AUX 3 & 4 send signals are summed together. This mono mix is available at both the AUX 3 & 4 OUTPUT jacks.

1-9. TALKBACK SYSTEM (312 & 320 ONLY)

Apply a -50 dBV signal to the talkback mic XLR connector. Select output buss(es) on the Talkback Assign Switch Rack. Press the T/B switch and, by increasing the TALKBACK LEVEL control setting, confirm that the signal connected is available at the selected output jack(s). When assigned to the STEREO OUT busses, the signal is available at both the STEREO OUT L & R jacks.

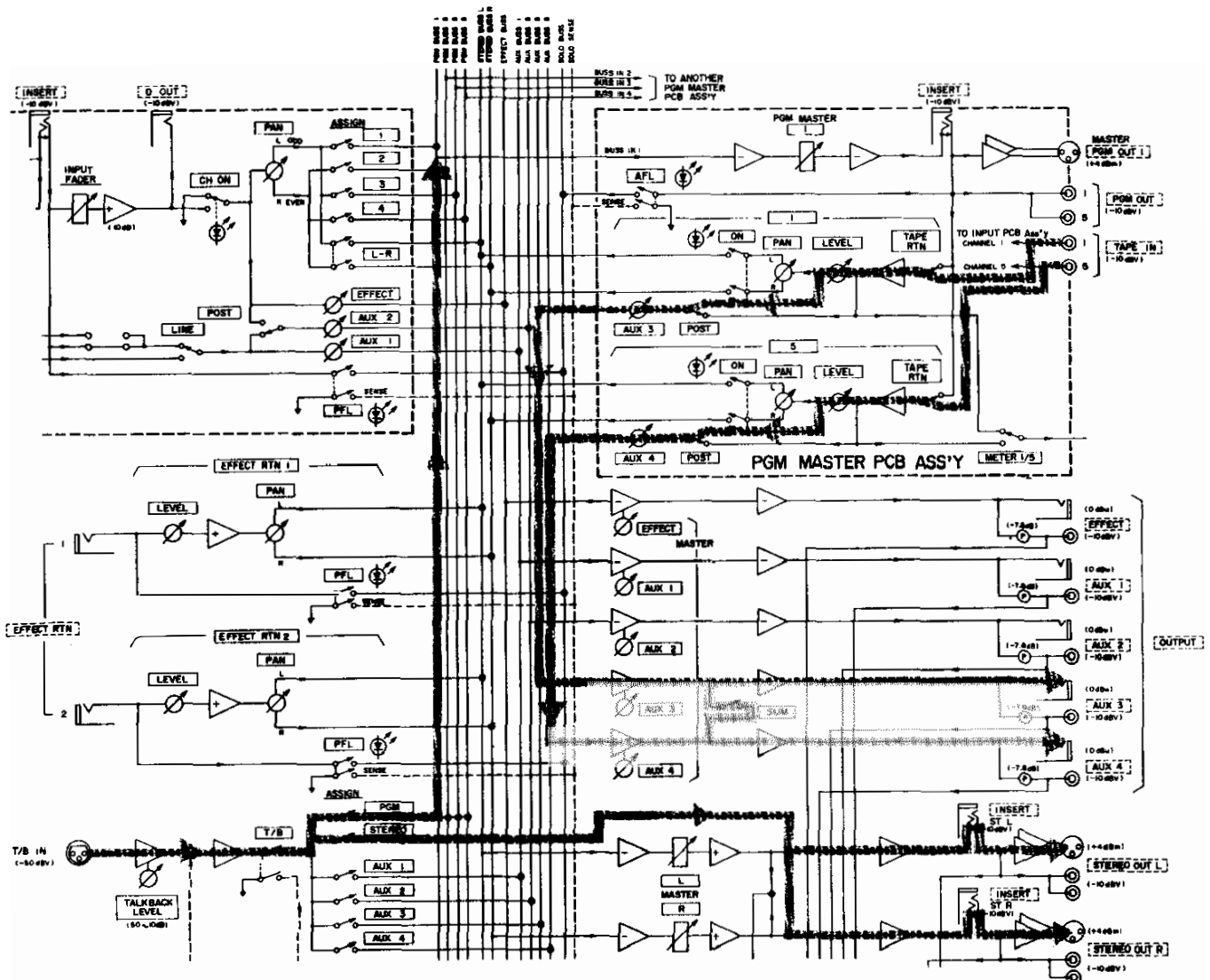

1-10. FREQUENCY RESPONSE

Set the input and output levels to nominal as in previous paragraphs and connect an oscillator to the input jack and a wide range (more than 100 kHz) level meter to the output jack.

Frequency response ranges are as follows:

MIC IN → PGM OUT 20 Hz – 30 kHz $\begin{matrix} +1 \\ -2 \end{matrix}$ dB

Other Inputs → Other Outputs
20 Hz – 30 kHz $\begin{matrix} +1 \\ -2 \end{matrix}$ dB

1-11. T.H.D.

T.H.D. is also measured with the input and output levels set to nominal as previously described. Connect a low distortion oscillator to the input jack, and a 30-kHz L.P.F. and a distortion meter to the output jack. Set the oscillator

output to 1 kHz and read the distortion meter.

Specs are as follows:

1 MIC IN → PGM OUT	0.025 % or less
1 LINE IN → PGM OUT	0.02 % or less
1 LINE IN → STEREO OUT	0.02 % or less
1 LINE IN → MON OUT	0.02 % or less
1 LINE IN → EFFECT OUT	0.02 % or less
1 LINE IN → AUX OUT	0.02 % or less
1 LINE IN → SOLO OUT	0.02 % or less

1-12. S/N RATIO

S/N ratio should be measured with the input and output levels set to nominal as previously described and a 150-ohm dummy load connected to the MIC IN connector.

Specs are given in the table below.

	308		312		320	
	DIN	IHF-A	DIN	IHF-A	DIN	IHF-A
Σ MIC TO PGM OUT (150 Ω SOURCE)	8 Σ MIC		12 Σ MIC		20 Σ MIC	
	60 dB	62 dB	52 dB	58 dB	50 dB	55 dB
LINE TO PGM OUT	86 dB	87 dB	←		←	
Σ LINE TO PGM OUT	8 Σ LINE		12 Σ LINE		20 Σ LINE	
	80 dB	82 dB	77 dB	80 dB	73 dB	75 dB
1 LINE TO EFF/AUX OUT	85 dB	87 dB	82 dB	84 dB	78 dB	80 dB
1 LINE TO ST OUTPUT	86 dB	88 dB	85 dB	87 dB	84 dB	86 dB
1 LINE TO MONO OUT	83 dB	85 dB	←		←	
1 LINE TO MON OUT	84 dB	86 dB	←		←	
1 LINE TO SOLO OUT	86 dB	88 dB	←		←	

EXPLODED VIEWS, ASSEMBLIES, PARTS LISTS AND CIRCUIT SCHEMATICS

INSTRUCTIONS FOR SERVICE PERSONNEL

BEFORE RETURNING APPLIANCE TO THE CUSTOMER, MAKE LEAKAGE-CURRENT OR RESISTANCE MEASUREMENTS TO DETERMINE THAT EXPOSED PARTS ARE ACCEPTABLY INSULATED FROM THE SUPPLY CIRCUIT.

NOTES

- ★ Parts marked with * require longer delivery time.
- ★ All resistors are 1/6 watt, 5 %, unless marked otherwise. Resistor values are in ohms (K=1,000 ohms, M=1,000,000 ohms)
- ★ All capacitor values are in microfarads (p=pico-farads).
- ★ \triangle Parts marked with this sign are safety critical components. They must always be replaced with identical components – refer to the TEAC Parts List and ensure exact replacement.
- ★ PC boards shown viewed from foil side.

INDEX

2. MECHANICS – EXPLODED VIEWS AND PARTS LISTS

2-1. Exploded View – 1 (Dress Panel – M-308)	2 - 1
2-2. Exploded View – 2 (Dress Panel – M-312/M-320)	2 - 3
2-3. Exploded View – 3 (Top Panel)	2 - 5
2-4. Exploded View – 4 (Meter Section, Side Chassis R Section)	2 - 7
2-5. Exploded View – 5 (Rear Panel)	2 - 9

3. ELECTRONICS – PCB'S AND ELECTRONIC COMPONENTS

3-1. INPUT PCB Ass'y	3 - 1, 3 - 2
3-2. INPUT JACK PCB Ass'y	3 - 2, 3 - 3
3-3. INPUT BUSS A PCB Ass'y	3 - 4
3-4. INPUT BUSS B PCB Ass'y (M-312/M-320)	3 - 4
3-5. INPUT BUSS C PCB Ass'y (M-320)	3 - 4
3-6. BUSS AMP PCB Ass'y	3 - 6
3-7. BUSS JACK PCB Ass'y	3 - 8
3-8. BAL AMP L PCB Ass'y	3 - 8
3-9. BAL AMP R PCB Ass'y	3 - 8
3-10. AUX PCB Ass'y	3 - 10
3-11. MONO AMP PCB Ass'y	3 - 12
3-12. MONITOR PCB Ass'y	3 - 13, 3 - 14
3-13. MON BUSS PCB Ass'y	3 - 16
3-14. METER PCB Ass'y	3 - 16
3-15. TALKBACK PCB Ass'y (M-312/M320)	3 - 18
3-16. JACK A PCB Ass'y	3 - 20
3-17. JACK B PCB Ass'y	3 - 20
3-18. JACK C PCB Ass'y	3 - 20
3-19. SUB IN PCB Ass'y	3 - 22
3-20. TB MIC PCB Ass'y (M-312/M-320)	3 - 22
3-21. TR PCB Ass'y (A)	3 - 23
3-22. TR PCB Ass'y (B)	3 - 23
3-23. POWER SUPPLY PCB Ass'y	3 - 24
3-24. SW PCB Ass'y	3 - 24
3-25. RIAA PCB Ass'y (M-308) (Japan Model Only)	3 - 27

4. SCHEMATIC DIAGRAMS

4-1. Wiring Diagram (M-308)	4 - 1
4-2. Wiring Diagram (M-312)	4 - 2
4-3. Wiring Diagram (M-320)	4 - 3
4-4. Input PCB Ass'y	4 - 4
4-5. Buss Amplifier PCB Ass'y (M-308)	4 - 5
4-6. Buss Amplifier PCB Ass'y (M-312/M-320)	4 - 6
4-7. Auxiliary PCB Ass'y (M-308)	4 - 7
4-8. Auxiliary PCB Ass'y (M-312/M-320)	4 - 8
4-9. Balanced Amplifier L PCB Ass'y	4 - 9
4-10. Balanced Amplifier R PCB Ass'y	4 - 10

4-11. Mono Amplifier PCB Ass'y (M-308)	4 - 11
4-12. Mono Amplifier PCB Ass'y (M-312/M-320)	4 - 12
4-13. Monitor PCB Ass'y (M-30B)	4 - 13
4-14. Monitor PCB Ass'y (M-312/M-320)	4 - 14
4-15. Meter PCB Ass'y	4 - 15
4-16. Talkback PCB Ass'y (M-312/M-320)	4 - 16
4-17. Power Supply Section (M-30B)	4 - 17
4-1B. Power Supply Section (M-312/M-320)	4 - 1B
4-19. RIAA PCB (M-308) (Japan Model Only)	4 - 19
4-20. IC Internal Block Diagrams	4 - 20
4-21. Block Diagram (M-30B)	4 - 21
4-22. Block Diagram (M-312/M-320)	4 - 22
4-23. Level Diagrams (M-30B)	4 - 23, 4 - 24
4-24. Level Diagrams (M-312/M-320)	4 - 25, 4 - 26

2. MECHANICS – EXPLODED VIEWS AND PARTS LISTS

2-1. EXPLODED VIEW-1 (DRESS PANEL – M-308)

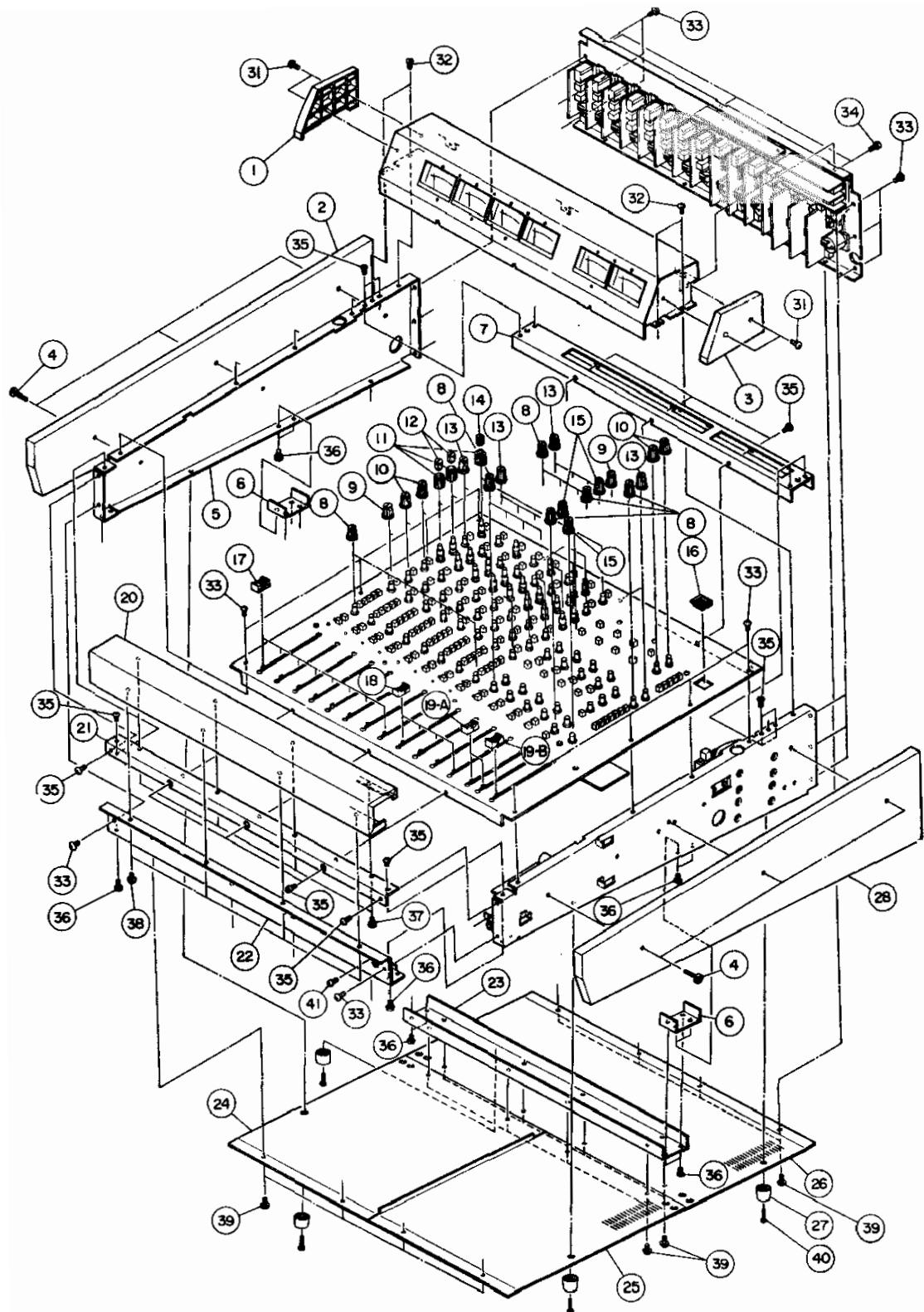

Exploded View—1

Parts marked with * require longer delivery time.

REF. NO.	PARTS NO.	DESCRIPTION	COMMON MODELS	REMARKS
1 - 1	*5800666000	Cover, Meter Ass'y; L		
1 - 2	*5800665100	Board, Side; L		
1 - 3	*5800666100	Cover, Meter Ass'y; R		
1 - 4	*5504411000	Screw Ass'y, Side Board		
1 - 5	*5800666801	Chassis, Side; L		
1 - 6	*5800662601	Holder, Bottom Cover Bracket		
1 - 7	*5800665501	Plate, Upper Reinforcement; A		
1 - 8	5800611300	Knob Ass'y, A (Ivory)	M-106	
1 - 9	5800611600	Knob Ass'y, D (Blue)	M-106	
1 - 10	5800611700	Knob Ass'y, E (Green)	M-106	
1 - 11	5800645800	Knob, B		
1 - 12	5800662300	Knob Ass'y, Small, C (Yellow)		
1 - 13	5800611500	Knob Ass'y, C (Yellow)		
1 - 14	5800662200	Knob Ass'y, Small, B (Red)		
1 - 15	5800611400	Knob Ass'y, B (Red)		
1 - 16	*5800607000	Escutcheon, A		
1 - 17	5800677100	Knob, Fader; G		
1 - 18	5800677200	Knob, Fader; H		
1 - 19A	5800677300	Knob, Fader; J		
1 - 19B	5800677400	Knob, Fader; K		
1 - 20	*5800667900	Pad Ass'y, A		
1 - 21	*5800664501	Angle, Front; A		
1 - 22	*5800665401	Panel, Front; A		
1 - 23	*5800664201	Bracket, Bottom Cover; A		
1 - 24	*5800668900	Cover, Bottom; L		
1 - 25	*5800669001	Cover, Bottom; R		
1 - 26	*5800669101	Cover, Bottom; A		
1 - 27	*5504676000	Foot, 19L		
1 - 28	*5800665200	Board, Side; R		
1 - 31	*5781073010	Screw, Pan Tapping; 3 x 10 (BLK)		
1 - 32	*5781023008	Screw Pan Tapping; 3 x 8		
1 - 33	*5780964008	Screw, Tras Tapping; 4 x 8 (BLK)		
1 - 34	*5781503008	Screw, Pan-washer Tapping; 3 x 8 (BLK)		
1 - 35	*5781024008	Screw, Pan Tapping; 4 x 8		
1 - 36	*5781074008	Screw, Pan Tapping; 4 x 8 (BLK)		
1 - 37	*5781023008	Screw, Pan Tapping; 3 x 8		
1 - 38	*5781503008	Screw, Pan-washer Tapping; 3 x 8 (BLK)		
1 - 39	*5781504008	Screw, Pan-washer Tapping; 4 x 8 (BLK)		
1 - 40	*5781024020	Screw, Pan Tapping; 4 x 20		
1 - 41	*5780963006	Screw, Tras Tapping; 3 x 6		

2-2. EXPLODED VIEW-2 (DRESS PANEL - M-312/M-320)

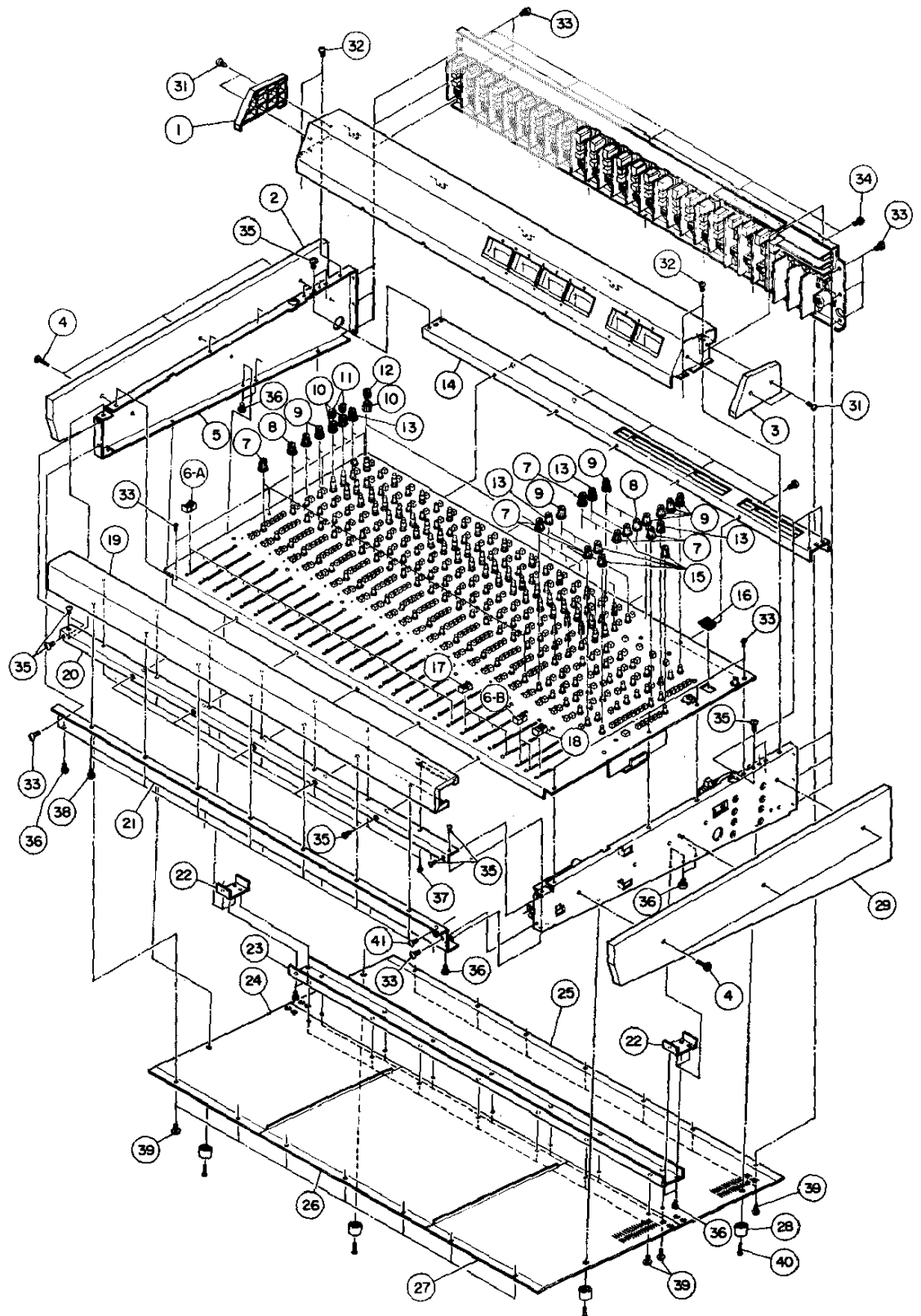

Exploded View-2 (M-320/M-312)

Parts marked with * require longer delivery time.

REF. NO.	PARTS NO.	DESCRIPTION	COMMON MODELS	REMARKS
2 - 1	*5800666000	Cover Meter Ass'y, L		
2 - 2	*5800665100	Board, Side; L		
2 - 3	*5800666100	Cover Meter Ass'y, R		
2 - 4	*5504411000	Screw Ass'y, Side Board		
2 - 5	*5800666801	Chassis, Side; L		
2 - 6A	5800677100	Knob, Fader; G		
2 - 68	5800677200	Knob, Fader; H		
2 - 7	5800611300	Knob Ass'y, A (Ivory)		
2 - 8	5800611600	Knob Ass'y, D (Blue)		
2 - 9	5800611700	Knob Ass'y, E (Green)		
2 - 10	5800645800	Knob, B		
2 - 11	5800662300	Knob Ass'y, Small; C (Yellow)		
2 - 12	5800662200	Knob Ass'y, Small; B (Red)		
2 - 13	5800611500	Knob Ass'y, C (Yellow)		
2 - 14	*5800665700	Plate, Upper Reinforcement; C		M-320
	*5800665601	Plate, Upper Reinforcement; B		M-312
2 - 15	5800611400	Knob Ass'y, B (Red)		
2 - 16	*5800607000	Escutcheon, A		
2 - 17	5800677200	Knob, Fader; H		
2 - 18	5800677400	Knob, Fader; K		
2 - 19	*5800668100	Pad Ass'y, C		M-320
	*5800668000	Pad Ass'y, B		M-312
2 - 20	*5800664701	Angle, Front; C		M-320
	*5800664601	Angle, Front; B		M-312
2 - 21	*5800665901	Panel, Front; C		M-320
	*5800665801	Panel, Front; B		M-312
2 - 22	*5800662601	Holder, Bottom Cover Bracket		
2 - 23	*5800664401	Bracket, Bottom Cover; C		M-320
	*5800664301	Bracket, Bottom Cover; B		M-312
2 - 24	*5800668900	Cover, Bottom; L		
2 - 25	*5800669301	Cover, Bottom; C		M-320
	*5800669201	Cover, Bottom; B		M-312
2 - 26	*5800669500	Cover, Bottom; E		M-320
	*5800669400	Cover, Bottom; D		M-312
2 - 27	*5800669001	Cover, Bottom; R		
2 - 28	*5504676000	Foot, 19L		
2 - 29	*5800665200	Board, Side; R		
2 - 31	*5781073010	Screw, Pan Tapping; 3 x 10 (BLK)		
2 - 32	*5781023008	Screw, Pan Tapping; 3 x 8		
2 - 33	*5780964008	Screw, Tras Tapping; 4 x 8 (BLK)		
2 - 34	*5781503008	Screw, Pan-washer Tapping; 3 x 8 (BLK)		
2 - 35	*5781024008	Screw, Pan Tapping; 4 x 8		
2 - 36	*5781074008	Screw, Pan Tapping; 4 x 8 (BLK)		
2 - 37	*5781023008	Screw, Pan Tapping; 3 x 8		
2 - 38	*5781503008	Screw, Pan-washer Tapping; 3 x 8 (BLK)		
2 - 39	*5781504008	Screw, Pan-washer Tapping; 4 x 8 (BLK)		
2 - 40	*5781024020	Screw, Pan Tapping; 4 x 20		
2 - 41	*5780963006	Screw, Tras Tapping; 3 x 6 (BLK)		

2-3. EXPLODED VIEW-3 (TOP PANEL)

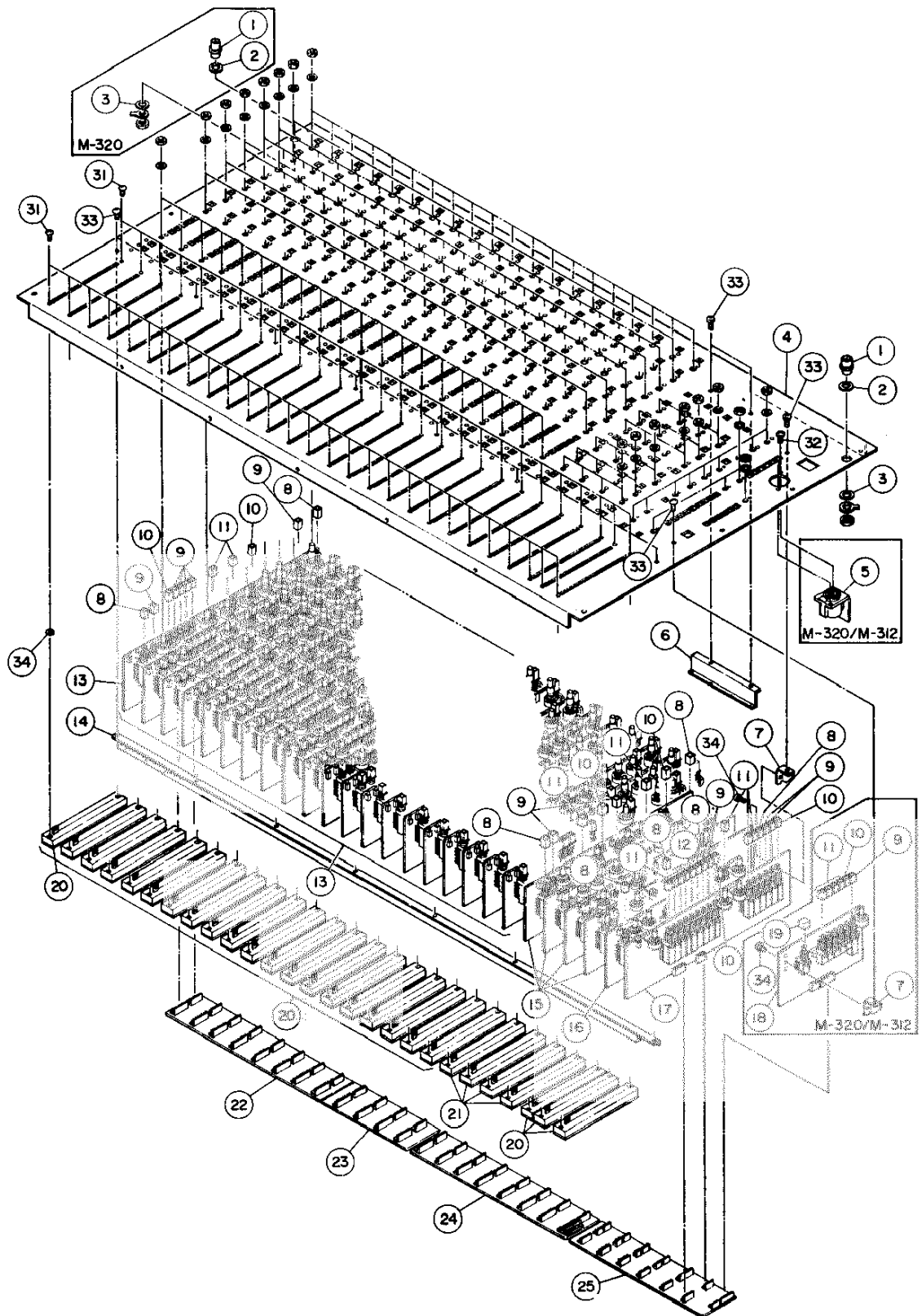

Exploded View—3

Parts marked with * require longer delivery time.

REF. NO.	PARTS NO.	DESCRIPTION	COMMON MODELS	REMARKS
3 - 1	5334041700	Connector Socket, BNC-type		M-320, M-312
3 - 2	*5800677500	Insulator		M-320, M-312
3 - 3	*5800662700	Washer, Insulating		M-320, M-312
3 - 4	*5800666201	Panel, Top; 20		M-320
	*5800666301	Panel, Top; 12		M-312
	*5800666401	Panel, Top; 8		M-308
3 - 5	*5200157700	PCB Ass'y, TB MIC		M-320, M-312
3 - 6	*5800664001	Bracket, BUSS PCB		
3 - 7	*5800663300	Support, PCB		
3 - 8	5600429400	Button, Push; C (Red)		
3 - 9	5800429200	Button, Push; A (Ivory)		
3 - 10	5800429300	Button, Push; 8 (Orange)		
3 - 11	5800429600	Button, Push; E (Green)		
3 - 12	5800429500	Button, Push; D (Blue)		
3 - 13	*5200155500	PCB Ass'y, INPUT		
3 - 14	*5800664800	Holder, PCB; A		M-308
	*5800664900	Holder, PCB; 8		M-312
	*5800665000	Holder, PCB; C		M-320
3 - 15	*5200155810	PCB Ass'y, BUSS AMP		M-320, M-312
	*5200155600	PCB Ass'y, BUSS AMP		M-308
3 - 16	*5200156110	PCB Ass'y, AUX		M-320, M-312
	*5200156100	PCB Ass'y, AUX		M-308
3 - 17	*5200156210	PCB Ass'y, MONITOR		M-320, M-312
	*5200156200	PCB Ass'y, MONITOR		M-308
3 - 18	*5200157600	PCB Ass'y, TB		M-320, M-312
3 - 19	5800475700	Button, P (I)		
3 - 20	5284009100	Ver. Res., Slide; 10 k Ω (D)		
3 - 21	5284009000	Ver. Res., Slide; 5 k Ω (D)		
3 - 22	*5200157900	PCB Ass'y, INP BUSS; C		M-320
3 - 23	*5200157800	PCB Ass'y, INP BUSS; B		M-320, M-312
3 - 24	*5200157100	PCB Ass'y, INP BUSS; A		
3 - 25	*5200157210	PCB Ass'y, MON BUSS		M-312, M-320
	*5200157200	PCB Ass'y, MON BUSS		M-308
3 - 31	*5780423006	Screw, Tras M3 x 6 (BLK)		
3 - 32	*5780423008	Screw, Tras; M3 x 8 (BLK)		
3 - 33	*5780963006	Screw, Tras Tapping; 3 x 6 (BLK)		
3 - 34	*5785113000	Lock Washer, ϕ 3 External Teeth		

2-4. EXPLODED VIEW-4 (METER SECTION, SIDE CHASSIS R SECTION)

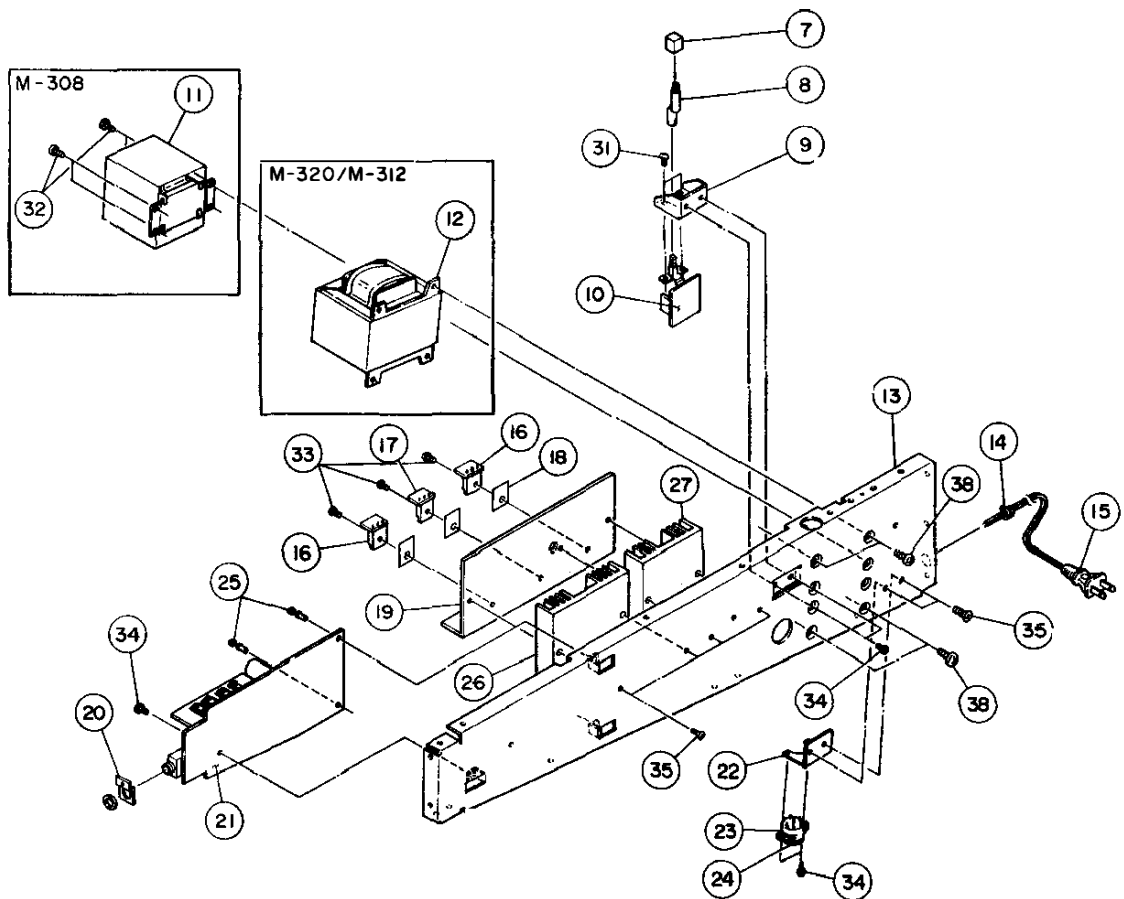
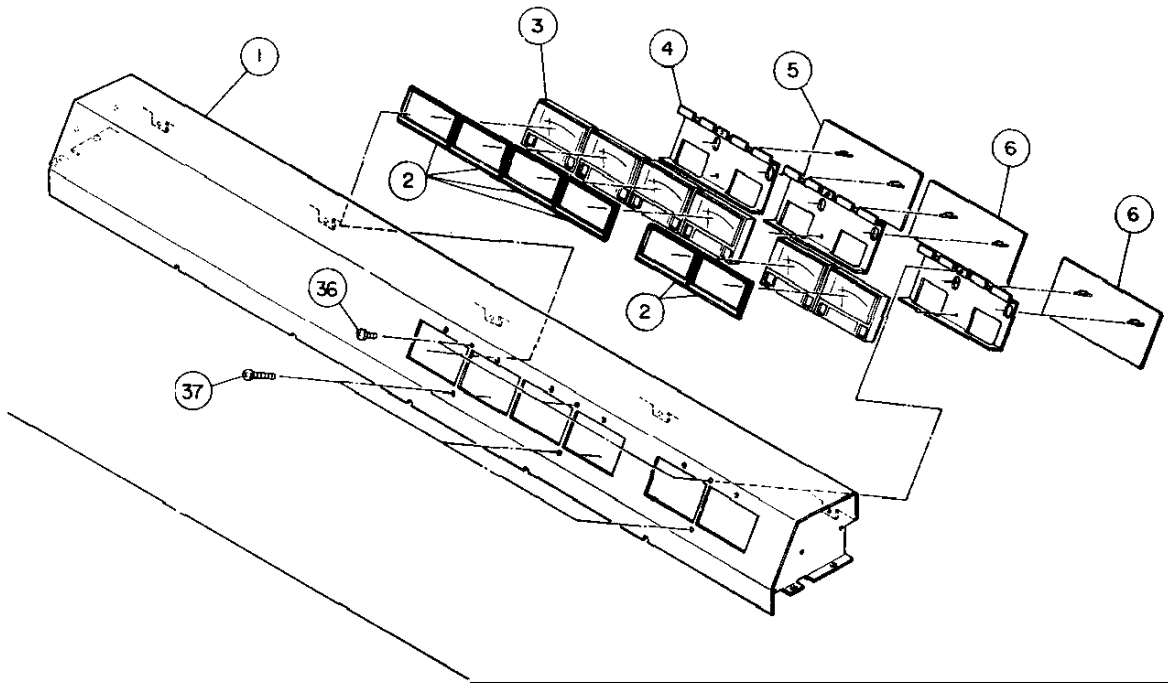

Exploded View—4

Parts marked with * require longer delivery time.

REF. NO.	PARTS NO.	DESCRIPTION	COMMON MODELS	REMARKS
4 - 1	*5800667301	Panel Ass'y, Meter; C		M-320
	*5800667201	Panel Ass'y, Meter; B		M-312
	*5800667101	Panel Ass'y, Meter; A		M-308
4 - 2	*5800606500	Escutcheon, Meter		
4 - 3	5296007100	Meter, VU		
4 - 4	*5800663400	Bracket, Meter		
4 - 5	*5200145800	PCB Ass'y, METER (P-901 : Mounted)		
4 - 6	*5200145810	PCB Ass'y, METER (P-901 : Not Mounted)		
4 - 7	5800278200	Button, Power		
4 - 8	*5800116200	Rod, A		
4 - 9	*5800663100	Bracket, Switch		
4 - 10	*5200145400	PCB Ass'y, SW [J, GE]		
	*5200145410	PCB Ass'y, SW [US]		
	*5200145420	PCB Ass'y, SW [C]		
	*5200145430	PCB Ass'y, SW [E, UK, A]		
4 - 11	△ 5320032600	Transformer, Power [J]		M-308
	△ 5320032700	Transformer, Power [US, C]		M-308
	△ 5320032800	Transformer, Power [E, UK, A]		M-308
	△ 5320032900	Transformer, Power [GE]		M-308
4 - 12	△ 5320033000	Transformer, Power [J]		M-320, M-312
	△ 5320033100	Transformer, Power [US, C]		M-320, M-312
	△ 5320033200	Transformer, Power [E, UK, A]		M-320, M-312
	△ 5320033300	Transformer, Power [GE]		M-320, M-312
4 - 13	*5800666901	Chassis, Side; R		
4 - 14	*5534660000	Bush, 4N-4 [J, GE, E, A]		
	*5317001700	Bush, 4N-5 [US, C, UK]		
4 - 15	△ *5128027000	Cord, AC Power [J]		
	△ *5350010700	Cord, AC Power [US, C]		
	△ *5350008200	Cord, AC Power [E]		
	△ *5128047000	Cord, AC Power [UK]		
	△ *5350008300	Cord, AC Power [A]		
	△ *5350010800	Cord, AC Power [GE]		
4 - 16	*5200145600	PCB Ass'y, TR A		
4 - 17	*5200145610	PCB Ass'y, TR B		
4 - 18		Plate, Insulating		
4 - 19	*5800665300	Heatsink		M-308
4 - 20	*5800663500	Bracket, HP Jack		
4 - 21	*5200158100	PCB Ass'y, POWER SUPPLY [J, GE]		M-320
	*5200158110	PCB Ass'y, POWER SUPPLY [US, C]		M-320
	*5200158120	PCB Ass'y, POWER SUPPLY [E, UK, A]		M-320
4 - 21	*5200157400	PCB Ass'y, POWER SUPPLY [J, GE]		M-312
	*5200157410	PCB Ass'y, POWER SUPPLY [US, C]		M-312
	*5200157420	PCB Ass'y, POWER SUPPLY [E, UK, A]		M-312
4 - 21	*5200155300	PCB Ass'y, POWER SUPPLY [J, GE]		M-308
	*5200155310	PCB Ass'y, POWER SUPPLY [US, C]		M-308
	*5200155320	PCB Ass'y, POWER SUPPLY [E, UK, A]		M-308
4 - 22	*5800663201	Bracket, Voltage Selector [GE]		
4 - 23	△ *5332014400	Socket, Voltage Selector [GE]		
4 - 24	△ *5043299000	Plug, Voltage Selector [GE]		
4 - 25	△ *5534118000	Rivet, Push		

(Continued on page 2-10)

[US]: U.S.A.
 [C]: CANADA
 [GE]: GENERAL EXPORT
 [A]: AUSTRALIA
 [E]: EUROPE
 [UK]: U.K.
 [L]: LIMITED AREA
 [J]: JAPAN

2-5. EXPLODED VIEW-5 (REAR PANEL)

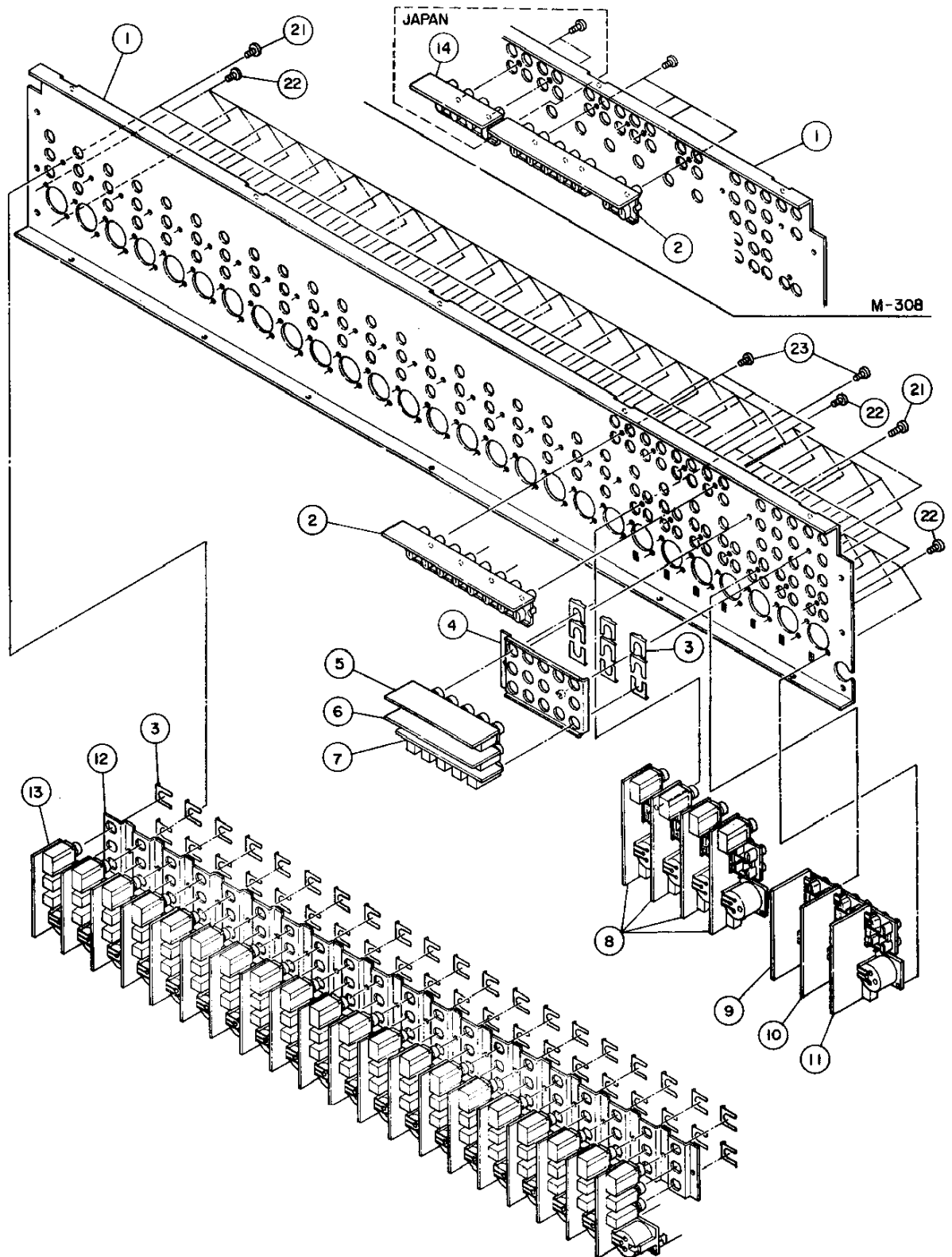

Exploded View—5

Parts marked with * require longer delivery time.

REF. NO.	PARTS NO.	DESCRIPTION	COMMON MODELS	REMARKS
5 - 1	*5800666701	Panel, Rear		M-320
	*5800666601	Panel, Rear		M-312
	*5800666501	Panel, Rear		M-308
	*5800670901	Panel, Rear [J]		M-308
5 - 2	*5200156310	PCB Ass'y, SUB IN		M-320, M-312
	*5200156300	PCB Ass'y, SUB IN		M-308
5 - 3	*5317003200	Plate, Jack Mounting		
5 - 4	*5800663601	Holder Ass'y, Jack		
5 - 5	*5200156900	PCB Ass'y, JACK A		
5 - 6	*5200157000	PCB Ass'y, JACK B		
5 - 7	*5200156410	PCB Ass'y, JACK C		M-320, M-312
	*5200156400	PCB Ass'y, JACK C		M-308
5 - 8	*5200155900	PCB Ass'y, BUSS JACK		
5 - 9	*5200156600	PCB Ass'y, BAL AMP L		
5 - 10	*5200156700	PCB Ass'y, BAL AMP R		
5 - 11	*5200156810	PCB Ass'y, MONO AMP		M-320, M-312
	*5200156800	PCB Ass'y, MONO AMP		M-308
5 - 12	*5800664100	Holder, Input Jack		
5 - 13	*5200155600	PCB Ass'y, INP JACK		
5 - 14	*5200163600	PCB Ass'y, RIAA [J]		M-308
5 - 21	*5781503008	Screw, Pan-washer Tapping; 3 x 8 (BLK)		
5 - 22	*5780423008	Screw, BIND; M3 x 8 (BLK)		
5 - 23	*5781073010	Screw, Pan Tapping; 3 x 8 (BLK)		

(Continued from page 2-8) Exploded View—4

REF. NO.	PARTS NO.	DESCRIPTION	COMMON MODELS	REMARKS
4 - 26	*5800674101	Heatsink B		M-312, M-320
4 - 27	*5800674201	Heatsink C		M-312, M-320
4 - 31	*5780133006	Screw, Pan Sems A; M3 x 6		
4 - 32	*5781024006	Screw, Pan Tapping; 4 x 6		
4 - 33	*5780003008	Screw, Bind; M3 x 8		
4 - 34	*5781023008	Screw, Pan Tapping; 3 x 8		
4 - 35	*5781223008	Screw, Flat Tapping; 3 x 8		
4 - 36	*5781162606	Screw, Bind Tapping; 2.6 x 6 (BLK)		
4 - 37	*5780022618	Screw, Bind; M2.6 x 18 (BLK)		
4 - 38	*5781024006	Screw, Pan Tapping 4 x 8		

[US]: U.S.A.
 [A]: AUSTRALIA
 [L]: LIMITED AREA

[C]: CANADA
 [E]: EUROPE
 [J]: JAPAN

[GE]: GENERAL EXPORT
 [UK]: U.K.

3. ELECTRONICS – PCB'S AND ELECTRONIC COMPONENTS

INPUT PCB Ass'y

REF. NO.	PARTS NO.	DESCRIPTION
	5200155500	PCB Ass'y
	5210155500	PCB
	IC's	
U101~U103	5220419600	NJM5532D
	TRANSISTORS	
Q101, Q102	5145119000	2SC1844 (F)
Q103	5230779520	2SC1815 (GR)
Q104	5145150000	2SA1015 (GR)
	DIODES	
D101, D102	5224015000	1SS133T77
D105, D106	5224015000	1SS133T77
D107, D108	5225005400	LED, SLP-135B (RED)
D109	5225006400	LED, SLP-235B (GRN)
	CARBON RESISTORS	
All resistors are rated $\pm 5\%$ tolerance 1/6W and of carbon type unless otherwise noted.		
R101, R102	5183562000	22 Ω 1/4W Nonflammable
R103, R104	5240028220	1k Ω
R105	5240025420	68 Ω
R106	5240029120	2.4k Ω
R107, R108	5240023420	10 Ω
R109, R110	5240030620	10k Ω
R111, R112	5240028620	1.5k Ω
R114	5240023820	15 Ω
R116, R117	5240029820	4.7k Ω
R118, R119	5240030620	10k Ω
R120, R121	5240033020	100k Ω
R122	5240028620	1.8k Ω
R123	5240029620	3.9k Ω
R124, R125	5240033020	100k Ω
R126, R127	5240031420	22k Ω
R128	5240029620	3.9k Ω
R130, R131	5240030620	10k Ω
R133, R134	5240030420	8.2k Ω
R135, R136	5240030620	10k Ω
R138, R139	5240030220	6.8k Ω
R140	5240033020	100k Ω
R141	5240025820	100 Ω
R142	5240033020	100k Ω
R143	5240030520	9.1k Ω
R144, R145	5240030620	10k Ω
R146	5240027220	390 Ω
R147	5240031420	22k Ω
R148, R149	5240027220	390 Ω
R150	5240033020	100k Ω
R151	5240028820	1.8k Ω
R152	5240029620	3.9k Ω
R153	5240025820	100 Ω
R154	5240033020	100k Ω
R156~R164	5240031420	22k Ω
R168	5240033020	100k Ω

REF. NO.	PARTS NO.	DESCRIPTION
CAPACITORS		
C101, C102	5260165252	Elec. 47 μ F 25V
C103, C104	5260162950	Elec. 10 μ F 63V
C105, C106	5172216000	Ceramic 220pF
C107, C108	5260162650	Elec. 10 μ F 25V
C109, C110	5173457000	Ceramic 100pF
C111	5172216000	Ceramic 330pF
C112	5173079000	Elec. 1000 μ F 6.3V
C113	5260163452	Elec. 22 μ F 25V
C114	5260162550	Elec. 10 μ F 16V
C115	5173457000	Ceramic 100pF
C116	5260165252	Elec. 47 μ F 25V
C117	5260162550	Elec. 10 μ F 16V
C118	5173449000	Ceramic 22pF
C119	5170366000	Meta. 0.0039 μ F
C120	5173453000	Ceramic 47pF
C121	5263102620	Poly. 0.0075 μ F
C122	5263166023	Meta. 0.0027 μ F
C123	5173453000	Ceramic 47pF
C124	5263104020	Poly. 0.03 μ F
C125	5263103020	Poly. 0.011 μ F
C126	5260165252	Elec. 47 μ F 25V
C127	5260160550	Elec. 0.47 μ F 50V
C128	5260162550	Elec. 10 μ F 16V
C129	5173457000	Ceramic 100pF
C130	5260165252	Elec. 47 μ F 25V
C131, C132	5173433000	Ceramic 0.01 μ F
VARIABLE RESISTORS		
R115	5282707400	5k Ω (RD) + 20 k Ω (A)
R129	5282013700	100k Ω (B) with c. click
R132, R137	5283505200	5k Ω (8) with c. click +200k Ω (C-C)
R155	5282410200	5k Ω (A-C) with c. click
R165~R167	5282013100	50k Ω (D)
CONNECTORS		
J105	5336164700	7P (F)
J106	5336165000	10P (F)
J107~J109	5122373000	2P (F)
SWITCHES		
S101~S105	5300037800	Push sw. 2-2N
S106	5300039100	Push sw. 2-2N 5 gang
S107	5300039200	Push sw. 2-2N
S108	5300039300	Push sw. 4-2N
MISCELLANEOUS		
	5181761000	Jumper wire, 5 mm
	5181771000	Jumper wire, 30 mm

3-1. INPUT PCB Ass'y

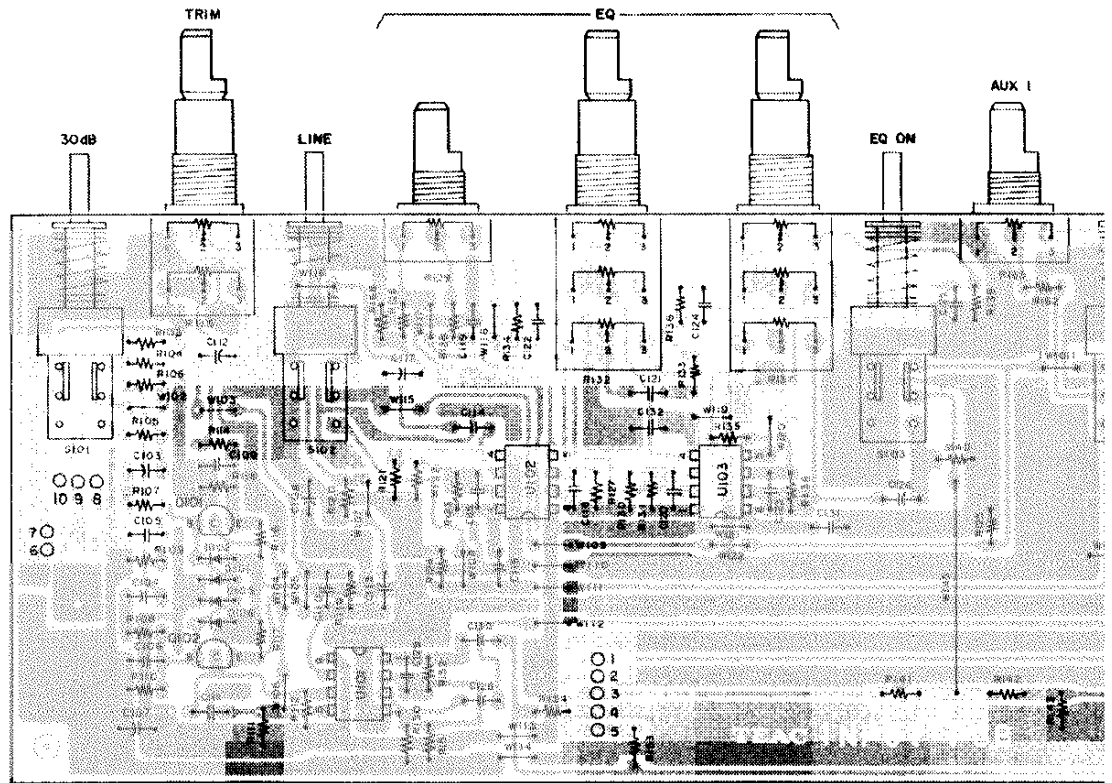

3-2. INPUT JACK PCB Ass'y

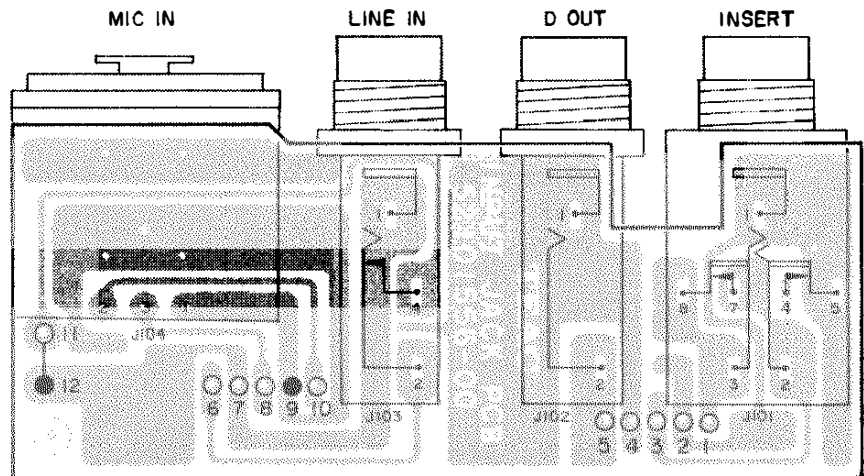

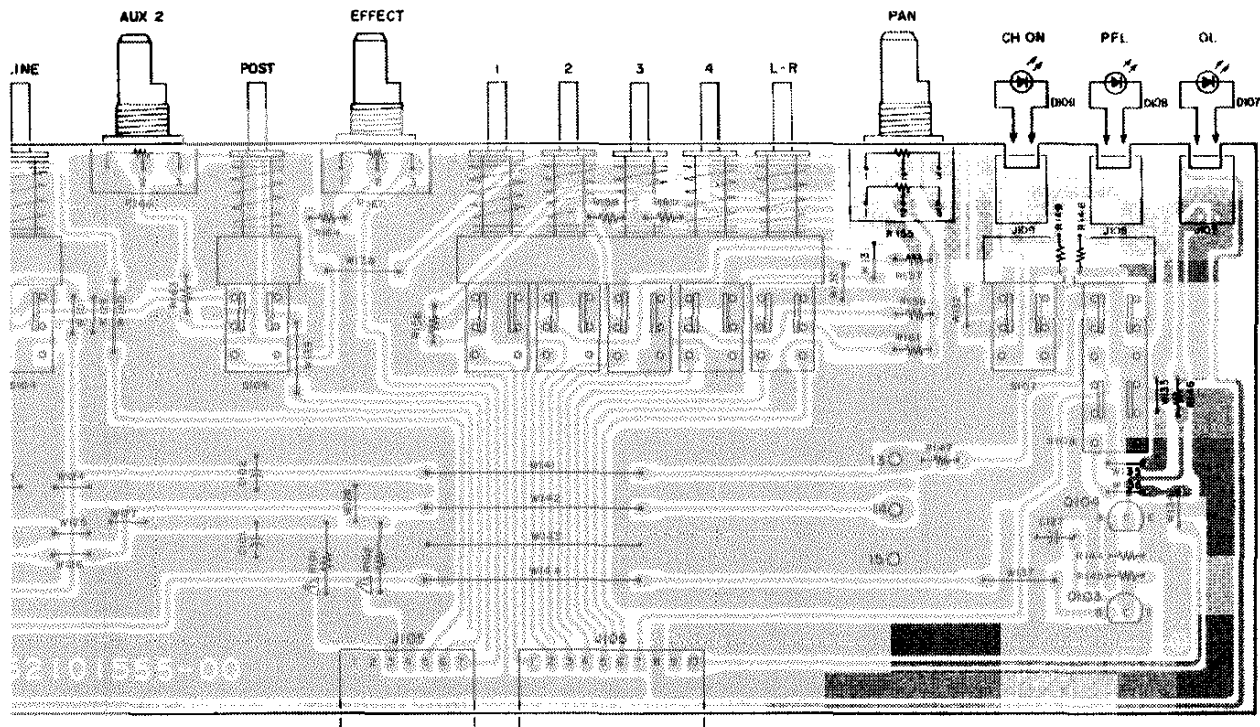

INP JACK PCB Ass'y

REF. NO.	PARTS NO.	DESCRIPTION
	5200155600	PCB Ass'y
	5210155600	PCB
J101	5330011400	1/4" Jack (TRS)
J102	5330011500	1/4" Jack (TRS)
J103	5330010800	1/4" Jack (SW)
J104	5330041400	XLB (F)
	5800664100	Holder, Input jack
	5317003200	Plate, Jack mounting
	5781012605	Screw, Pan head, Tapping M2.6 x 5

3-3. INPUT BUSS A PCB Ass'y

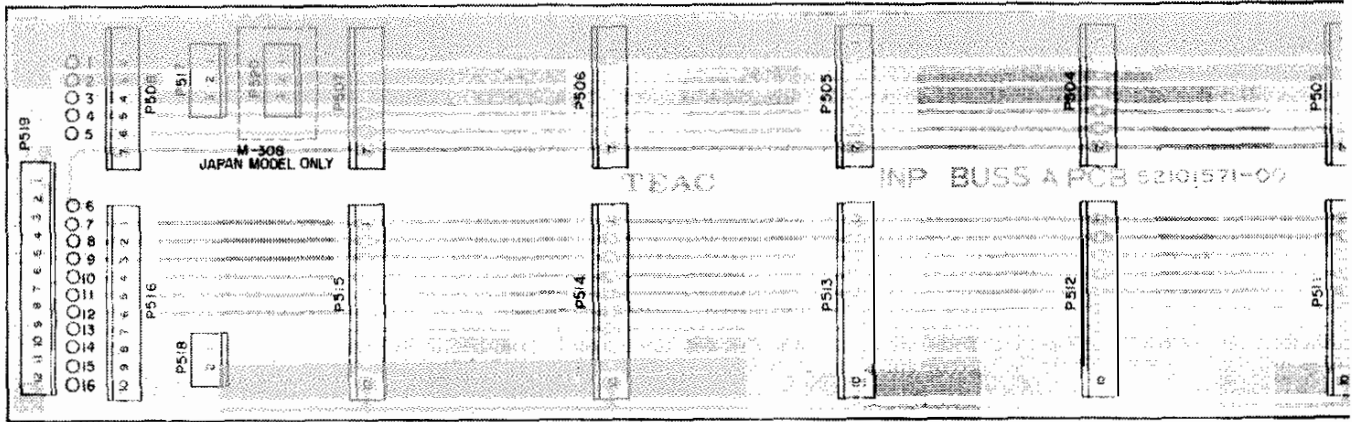

3-4. INPUT BUSS B PCB Ass'y

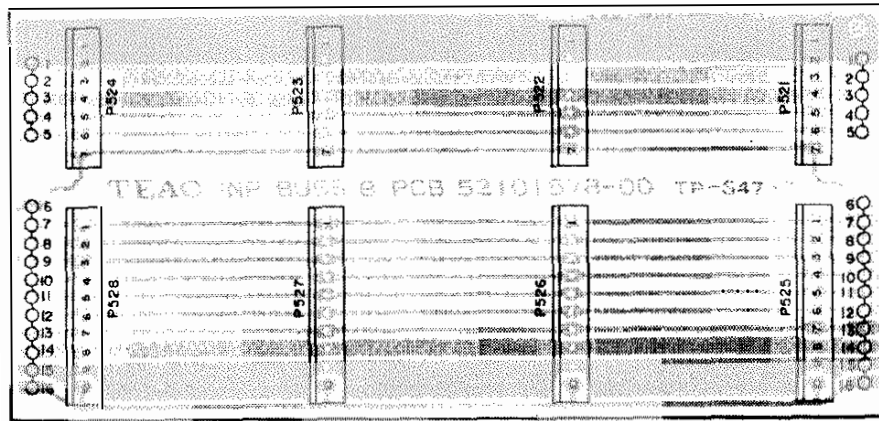

3-5. INPUT BUSS C PCB Ass'y

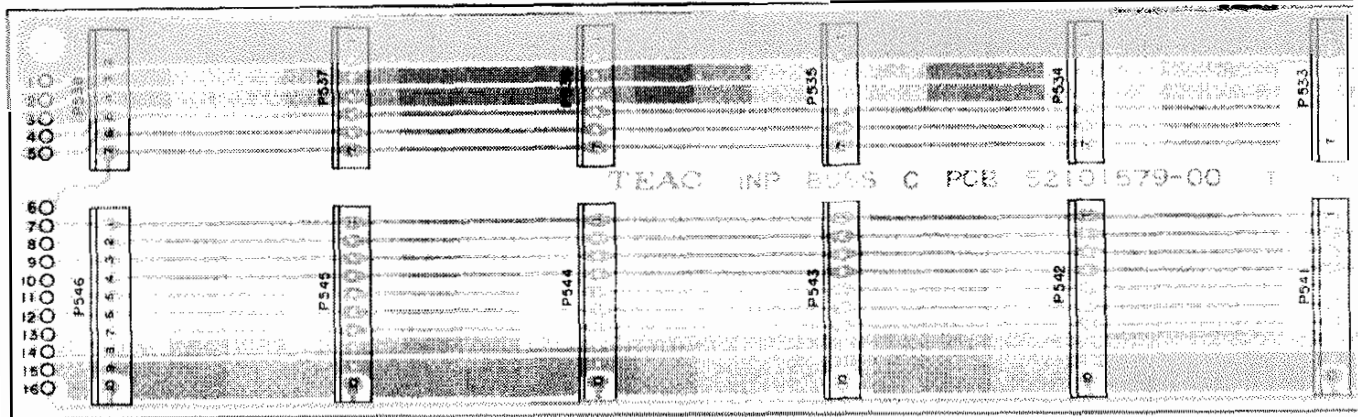

3-6. BUSS AMP PCB Ass'y

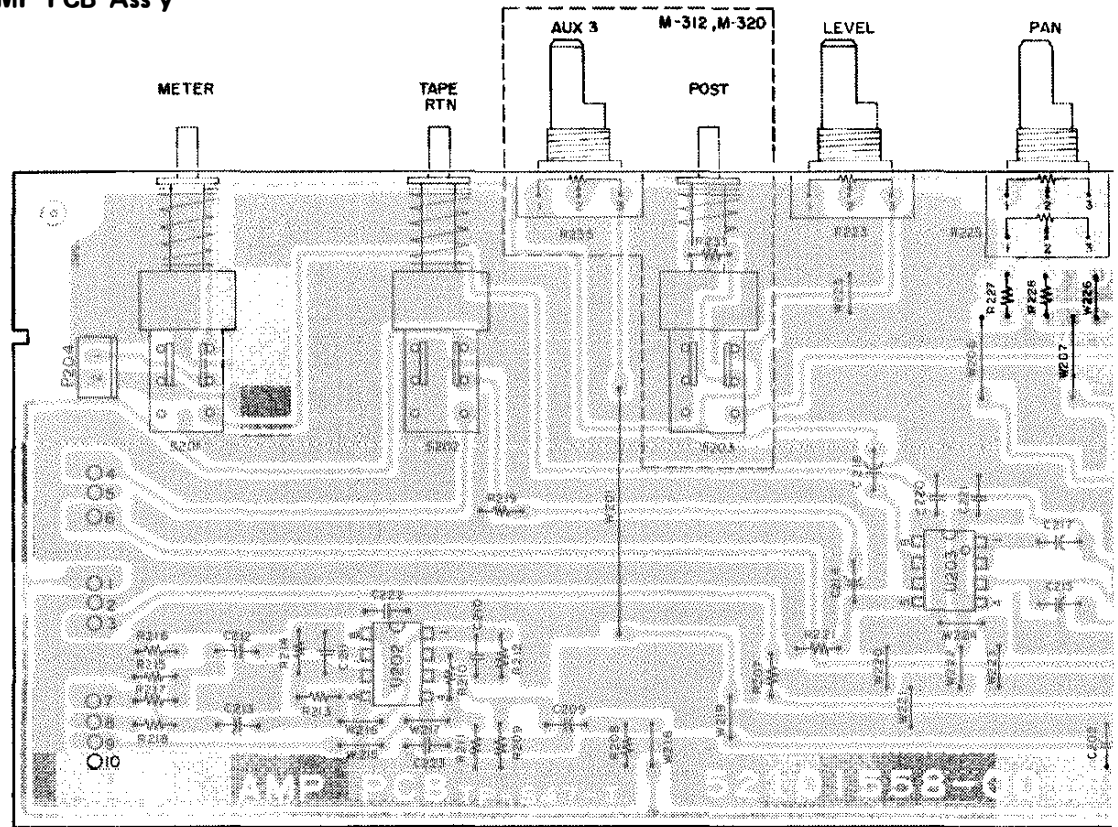

BUSS AMP PCB Ass'y

REF. NO.	PARTS NO.	DESCRIPTION
	5200155800	PCB Ass'y (M-308)
	5200155810	PCB Ass'y (M-312, M-320)
	5210155800	PCB
		IC's
U201	5220416600	NJM2041DD
U202	5220419600	NJM5532D
U203	5220416600	NJM2041DD
		DIODES
D201, D202	5225006400	LED, SLP-235B (GRN)
D203	5225005400	LED, SLP-1358 (RED)
		CARBON RESISTORS
All resistors are rated $\pm 5\%$ tolerance 1/6W and of carbon type unless otherwise noted.		
R201, R202	5183562000	22 Ω 1/4W Nonflammable
R203	5240031420	22k Ω
R204	5240030820	12k Ω
R205	5240032020	39k Ω
R206	5240033020	100k Ω

REF. NO.	PARTS NO.	DESCRIPTION
R207	5240025820	100 Ω
R208	5240034620	470k Ω
R209	5240032220	47k Ω
R210	5240029120	2.4k Ω
R211	5240029920	5.1k Ω
R212	5240030220	6.8k Ω
R213, R214	5240030620	10k Ω
R215, R216	5240033020	100k Ω
R217, R218	5240023420	10 Ω
R219, R220	5240034620	470k Ω
R221, R222	5240032220	47k Ω
R227~R230	5240031420	22k Ω
R231, R232	5240027220	390 Ω
R233, R234	5240031420	22k Ω
R237	5240031420	22k Ω
R238	5240027220	390 Ω
		CAPACITORS
C201, C202	5260165252	Elec. 47 μ F 25V
C203	5260165952	Elec. 100 μ F 10V
C204	5173449000	Ceramic 22pF
C205	5260165252	Elec. 47 μ F 25V
C206	5260162550	Elec. 10 μ F 16V

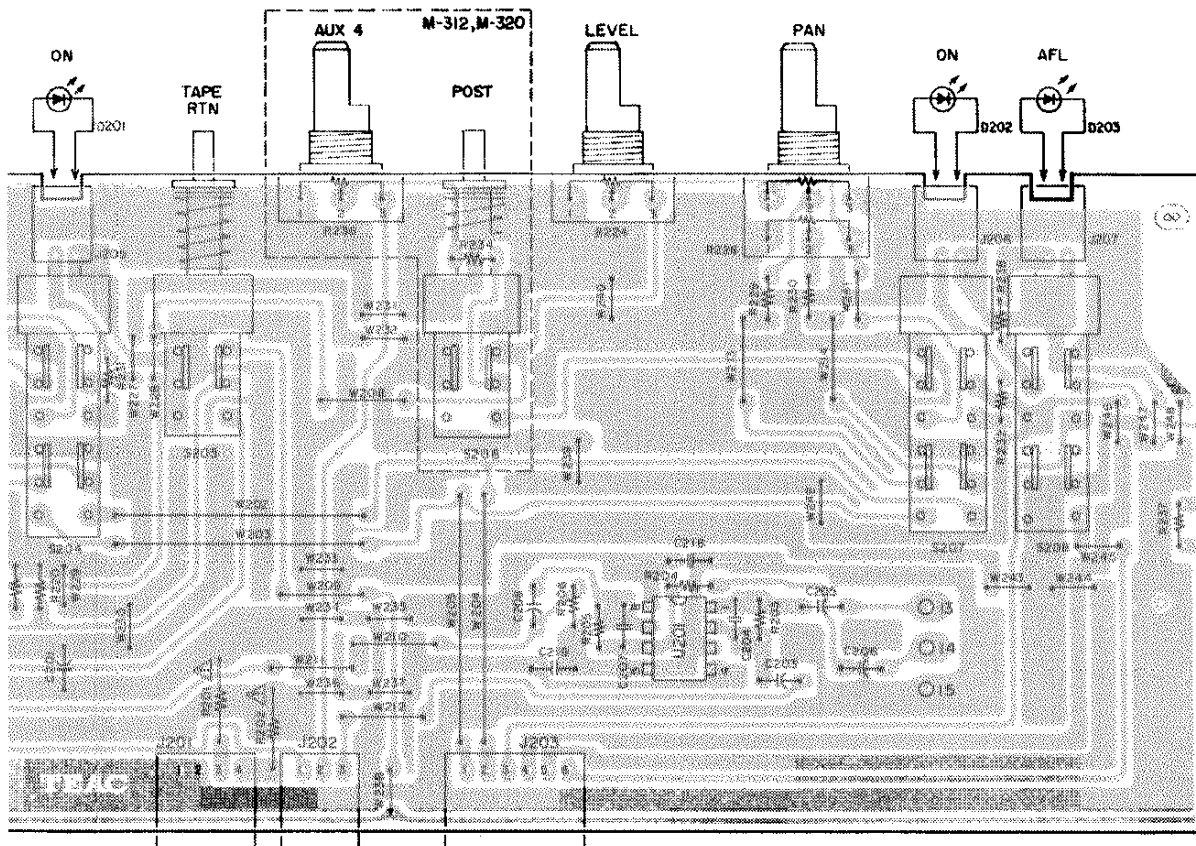

REF. NO.	PARTS NO.	DESCRIPTION
C207	5173449000	Ceramic 22pF
C208	5260163452	Elec. 22μF 25V
C209	5260162550	Elec. 10μF 16V
C210	5173457000	Ceramic 100pF
C211	5173453000	Ceramic 47pF
C212, C213	5260166052	Elec. 100μF 25V
C214, C215	5260162550	Elec. 10μF 16V
C216, C217	5260165252	Elec. 47μF 25V
C218, C223	5173433000	Ceramic 0.01μF
VARIABLE RESISTORS		
R223, R224	5282013800	5kΩ (A)
R225, R226	5282409700	20kΩ (A-C) with c. click
R235, R236	5282013100	50kΩ (D) (M-313, M-320)
CONNECTORS		
J201	5336164400	4P (F)
J202	5336164300	3P (F)
J203	5336164600	6P (F)
P204	5336126200	2P (M)
J205~J207	5122373000	2P (F)

REF. NO.	PARTS NO.	DESCRIPTION
SWITCHES		
S201	5300039200	Push sw. 2-2N
S202	5300037800	Push sw. 2-2N
S203	5300037800	Push sw. 2-2N (M-312, M-320)
S204	5300039300	Push sw. 4-2N
S205	5300037800	Push sw. 2-2N
S206	5300037800	Push sw. 2-2N (M-312, M-320)
S207, S208	5300039300	Push sw. 4-2N
MISCELLANEOUS		
	5181771000	Jumper wire, 30 mm
	5181761000	Jumper wire, 5 mm

3-7. BUSS JACK PCB Ass'y

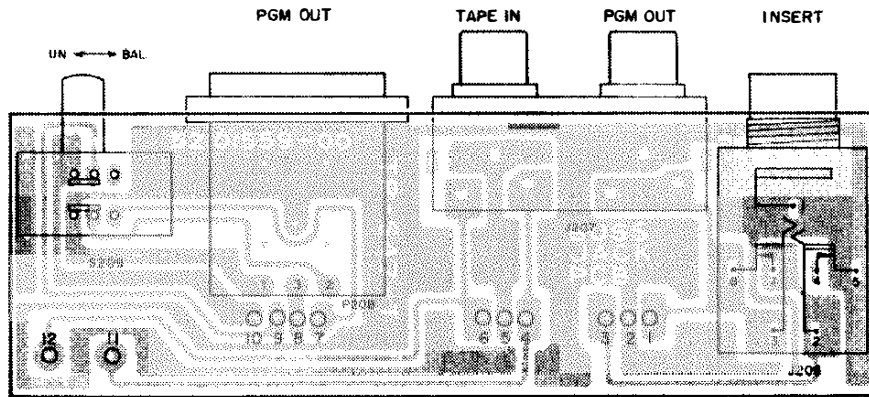

3-8. BAL AMP L PCB Ass'y

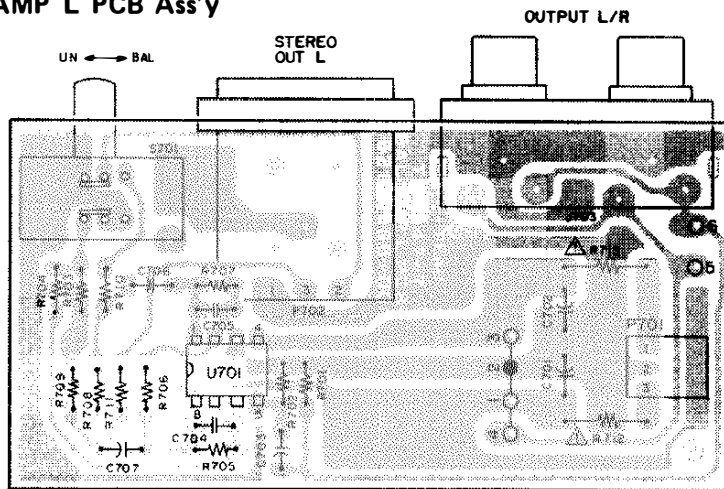

3-9. BAL AMP R PCB Ass'y

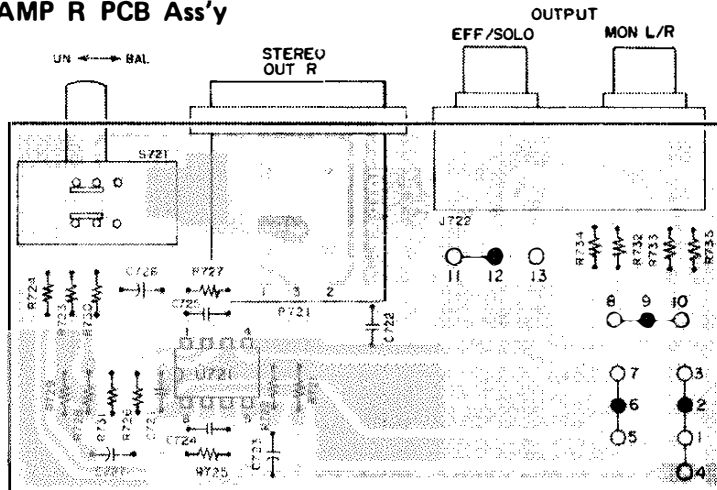

BUSS JACK PCB Ass'y

REF. NO.	PARTS NO.	DESCRIPTION
	5200155900	PCB Ass'y
	5210155900	PCB
J206	5330011400	1/4" Jack (TRS)
J207	5330509500	RCA pin jack, 4P
P208	5334041500	XLB (M)
S209	5300911400	Slide sw. 2-2N
	5781012605	Screw, Pan head, Tapping M2.6 x 5

BAL AMP L PCB Ass'y

REF. NO.	PARTS NO.	DESCRIPTION
	5200156600	PCB Ass'y
	5210156600	PCB
		IC
U701	5220419600	NJM5532D
		CARBON RESISTORS
		All resistors are rated $\pm 5\%$ tolerance 1/6W and of carbon type unless otherwise noted.
R701	5240034620	470k Ω
R702	5240032220	47k Ω
R703	5240029920	5.1k Ω
R704	5240029120	2.4k Ω
R705	5240030220	6.8k Ω
R706, R707	5240030620	10k Ω
R708, R709	5240033020	100k Ω
R710, R711	5240023400	10 Ω
R712, R713	5183562000	22 Ω 1/4W Nonflammable
		CAPACITORS
C701, C702	5260165252	Elec. 47 μ F 25V
C703	5260162550	Elec. 10 μ F 16V
C704	5173457000	Ceramic 100pF
C705	5173453000	Ceramic 47pF
C706, C707	5260166100	Elec. 100 μ F 25V
		MISCELLANEOUS
P701	5336128300	Connector, 3P (M)
P702	5334041500	XLB (M)
J703	5330509500	RCA jack, 4P
S701	5300911400	Slide sw. 2-2N
	5781012605	Screw, Pan head, Tapping M2.6 x 5

BAL AMP R PCB Ass'y

REF. NO.	PARTS NO.	DESCRIPTION
	5200156700	PCB Ass'y
	5210156700	PCB
		IC
U721	5220419600	NJM5532D
		CARBON RESISTORS
		All resistors are rated $\pm 5\%$ tolerance 1/6W and of carbon type unless otherwise noted.
R721	5240034620	470k Ω
R722	5240032220	47k Ω
R723	5240029920	5.1k Ω
R724	5240029120	2.4k Ω
R725	5240030220	6.8k Ω
R726, R727	5240030620	10k Ω
R728, R729	5240033020	100k Ω
R730, R731	5240023420	10 Ω
R732, R733	5240028420	1.2k Ω
R734, R735	5240028020	820 Ω
		CAPACITORS
C721, C722	5173433000	Ceramic 0.01 μ F
C723	5260162550	Elec. 10 μ F 16V
C724	5173457000	Ceramic 100pF
C725	5173453000	Ceramic 47pF
C726, C727	5260166152	Elec. 100 μ F 25V
		MISCELLANEOUS
P721	5334041500	XLB (M)
J722	5330509500	RCA jack, 4P
S721	5300911400	Slide sw. 2-2N
	5181761000	Jumper wire, 5 mm
	5781012605	Screw, Pan head, Tapping M2.6 x 5

3-10. AUX PCB Ass'y

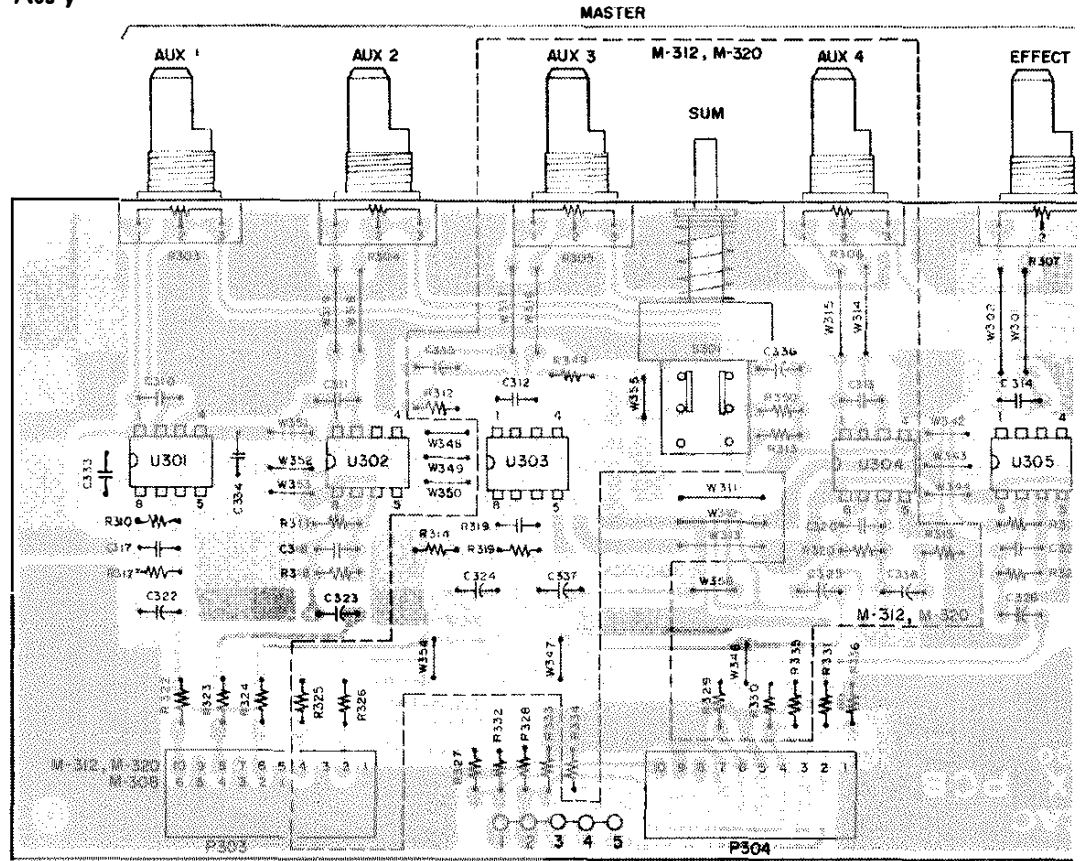

AUX PCB Ass'y

REF. NO.	PARTS NO.	DESCRIPTION
	5200156100	PCB Ass'y (M-308)
	5200156110	PCB Ass'y (M-312, M-320)
	5210156100	PCB
		IC's
U301, U302	5220416800	NJM072D-E
U303, U304	5220416800	NJM072D-E (M-312, M-320)
U305	5220416800	NJM072D-E
U306	5220416600	NJM2041DD
		DIODES
D301, D302	5225005400	LED, SLP-1358 (RED)
		CARBON RESISTORS
All resistors are rated ±5% tolerance 1/6W and of carbon type unless otherwise noted.		
R301, R302	5183620000	22Ω 1/4W Nonflammable
R308, R309	5240031420	22kΩ
R310, R311	5240029820	4.7kΩ
R312, R313	5240029820	4.7kΩ (M-312, M-320)
R314, R315	5240033020	100kΩ (M-312, M-320)

REF. NO.	PARTS NO.	DESCRIPTION
R316	5240029820	4.7kΩ
R317, R318	5240031020	15kΩ
R319, R320	5240031020	15kΩ (M-312, M-320)
R321	5240031020	15kΩ
R322, R323	5240024220	22Ω
R324	5240024220	22Ω
R325, R326	5240024220	22Ω (M-312, M-320)
R327, R328	5240028420	1.2kΩ
R329, R330	5240028420	1.2kΩ (M-312, M-320)
R331	5240028420	1.2kΩ
R332, R333	5240028020	820Ω
R334, R335	5240028020	820Ω (M-312, M-320)
R336	5240028020	820Ω
R337~R340	5240031420	22kΩ
R345, R346	5240032420	56kΩ
R347, R348	5240027220	390Ω
R349, R350	5240029820	4.7kΩ (M-312, M-320)
		CAPACITORS
C301, C302	5260165252	Elec. 47μF 25V
C303, C304	5260165952	Elec. 100μF 10V
C305, C306	5260165952	Elec. 100μF 10V
		(M-312, M-320)
C307~C309	5260165952	Elec. 100μF 10V

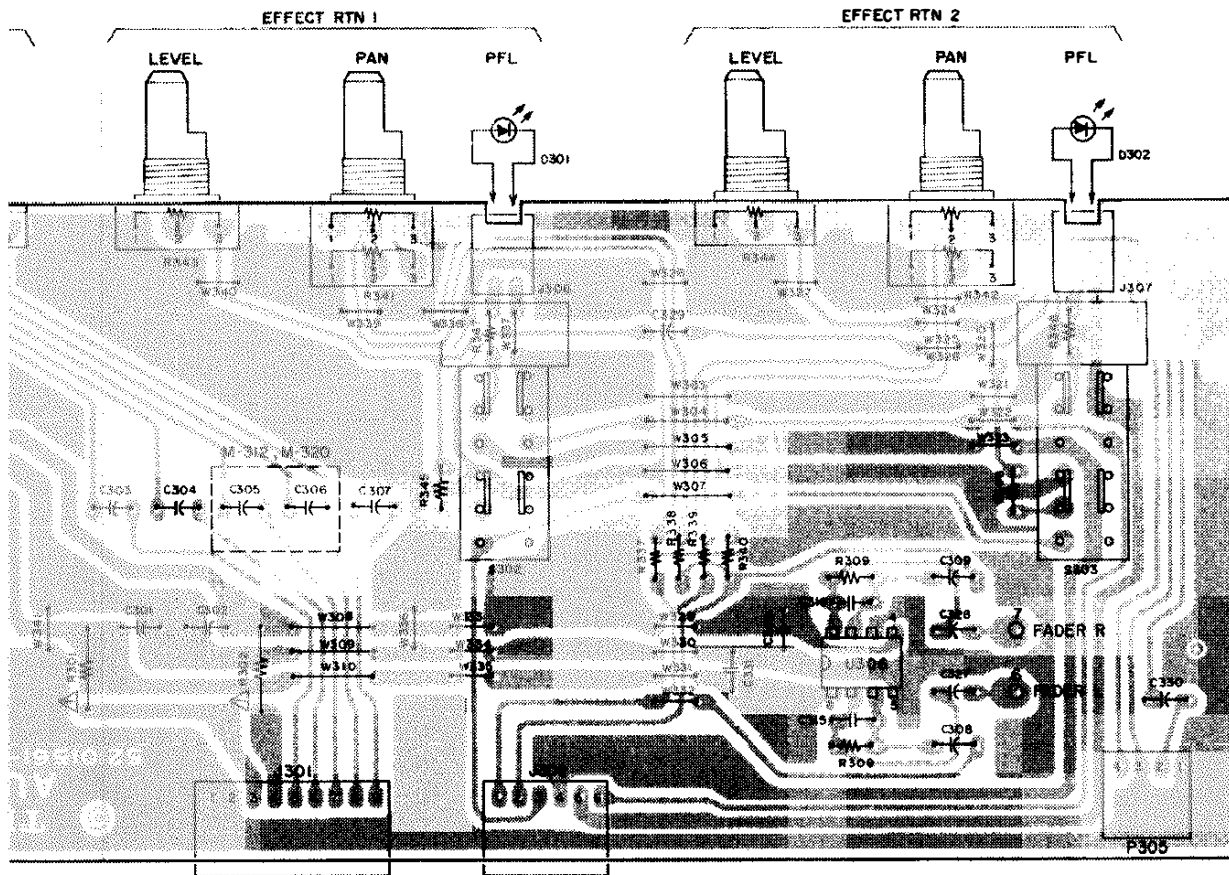

REF. NO.	PARTS NO.	DESCRIPTION
C310, C311	5173449000	Ceramic 22pF
C312, C313	5173449000	Ceramic 22pF
		(M-312, M-320)
C314~C316	5173449000	Ceramic 22pF
C317, C318	5173456000	Ceramic 68pF
C319, C320	5173455000	Ceramic 68pF
		(M-312, M-320)
C321	5173455000	Ceramic 68pF
C322, C323	5260165252	Elec. 47µF 25V
C324, C325	5260165252	Elec. 47µF 25V
		(M-312, M-320)
C326~C330	5260165252	Elec. 47µF 25V
C331~C334	5173433000	Ceramic 0.01µF
C335, C336	5260165252	Elec. 47µF 25V
		(M-312, M-320)
C337, C338	5260165052	Elec. 47µF 10V
		(M-312, M-320)
VARIABLE RESISTORS		
R303, R304	5282013100	50kΩ (D)
R305, R306	5282013100	50kΩ (D) (M-313, M-32)
R307	5282013100	50kΩ (D)
R341, R342	5282409700	20kΩ (A-C) with c. click
R343, R344	5282011500	10kΩ (A)

REF. NO.	PARTS NO.	DESCRIPTION
CONNECTORS		
J301	5336164900	9P (F)
J302	5336164600	6P (F)
P303	5336128600	6P (M) (M-308)
P304	5336129000	10P (M) (M-312, M-320)
P305	5336128400	4P (M)
J306, J307	5122373000	2P (F)
SWITCHES		
S301	5300037800	Push sw. 2-2N (M-312, M-320)
S302, S303	5300039300	Push sw. 4-2N
MISCELLANEOUS		
	5181761000	Jumper wire, 5mm
	5181763000	Jumper wire, 10mm
	5181764000	Jumper wire, 12.5mm

MONITOR PCB Ass'y

REF. NO.	PARTS NO.	DESCRIPTION
	5200156200	PCB Ass'y (M-308)
	5200156210	PCB Ass'y (M-312, M-320)
	5210156200	PCB
		IC's
U401~U403	5220416600	NJM2041DD
U404	5220468000	NJM072DE
U405	5220362000	LC4966
U406	5220416600	NJM2041DD
		TRANSISTORS
Q401, Q402	5146151000	2SC1815 (GR)
Q403	5145150000	2SA1015 (GR)
Q404	5145151000	2SC1815 (GR)
		DIODES
D401~D404	5224015000	1S133T77
D405	5225009700	LED Ass'y, ALE0606-AR
		CARBON RESISTORS
All resistors are rated $\pm 5\%$ tolerance 1/6W and of carbon type unless otherwise noted.		
R401, R402	5183562000	22 Ω 1/4W Nonflammable
R403, R404	5240033020	100k Ω
R405, R406	5240028820	1.8k Ω
R407, R408	5240029820	3.9k Ω
R409~R414	5240030620	10k Ω
R415, R416	5240033020	100k Ω
R417, R418	5240025820	100 Ω
R419	5240029820	4.7k Ω
R420	5240033020	100k Ω
R421	5240028820	1.8k Ω
R422	5240029620	3.9k Ω
R423	5240025820	100 Ω
R424	5240033020	100k Ω
R426	5240030620	10k Ω
R427	5240031820	33k Ω
R428	5240033020	100k Ω
R429	5240025820	100 Ω
R431, R432	5240033020	100k Ω
R433, R434	5240028220	1k Ω
R435, R436	5240030220	6.8k Ω
R437, R438	5240033020	100k Ω
R439, R440	5240024220	22 Ω
R442~R445	5240030620	10k Ω
R446	5240026620	220 Ω
R447~R452	5240033020	100k Ω
R453	5240031420	22k Ω
		CAPACITORS
C401, C402	5260165252	Elec. 47 μ F 25V
C403, C404	5260625500	Elec. 10 μ F 16V
C405~C408	5173457000	Ceramic 100pF
C409, C410	5260165252	Elec. 47 μ F 25V
C411	5173457000	Ceramic 100pF
C412	5260165252	Elec. 47 μ F 26V
C413	5260162550	Elec. 10 μ F 16V
C414	5173457000	Ceramic 100pF
C415	5260165252	Elec. 47 μ F 25V

REF. NO.	PARTS NO.	DESCRIPTION
C416	6260165952	Elec. 100 μ F 10V
C417, C418	5173449000	Ceramic 22pF
C419	6260165252	Elec. 47 μ F 25V
C420, C421	5260162560	Elec. 10pF 16V
C422, C423	5173457000	Ceramic 100pF
C424, C425	5260165252	Elec. 47 μ F 25V
C426~C428	5173433000	Ceramic 0.01 μ F
C429	5260165252	Elec. 47 μ F 25V
C430	5260162560	Elec. 10 μ F 16V
		VARIABLE RESISTORS
R425	5282013800	5k Ω (A)
R430	5282410300	20k Ω (A-A)
R441	6282410300	20k Ω (A-A)
		CONNECTORS
J4D1	5336164400	4P (F)
J4O2	5336164700	7P (F)
P4O3	5336128600	6P (M)
P4O4	5336128800	8P (M)
P4O5	5336128200	2P (M)
P4O6	5336128700	7P (M)
P4O7	5336128400	4P (M)
J4O8	612237300	2P (F)
		SWITCHES
S401	5300039000	Push sw. 2-2N 6 gang (M-308)
S401	5300038900	Push sw. 2-2N 6 gang (M-312, M-320)
S402	5300039400	Push sw. 2-2N 7 gang (M-308)
S402	5300039500	Push sw. 2-2N 9 gang (M-312, M-320)
		MISCELLANEOUS
	5181761000	Jumper wire, 5 mm
	5181763000	Jumper wire, 10 mm
	5800663300	Support, PCB
	5781023008	Screw, Pan head tapping M3 x 8

3-12. MONITOR PCB Ass'y

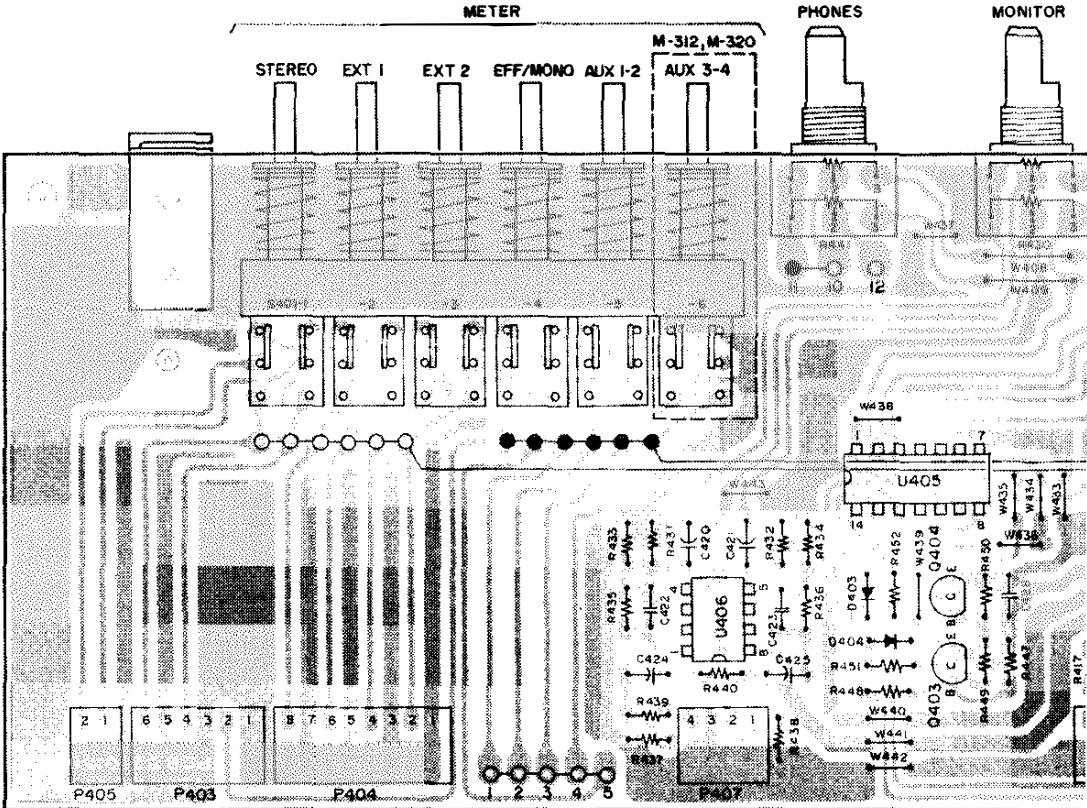

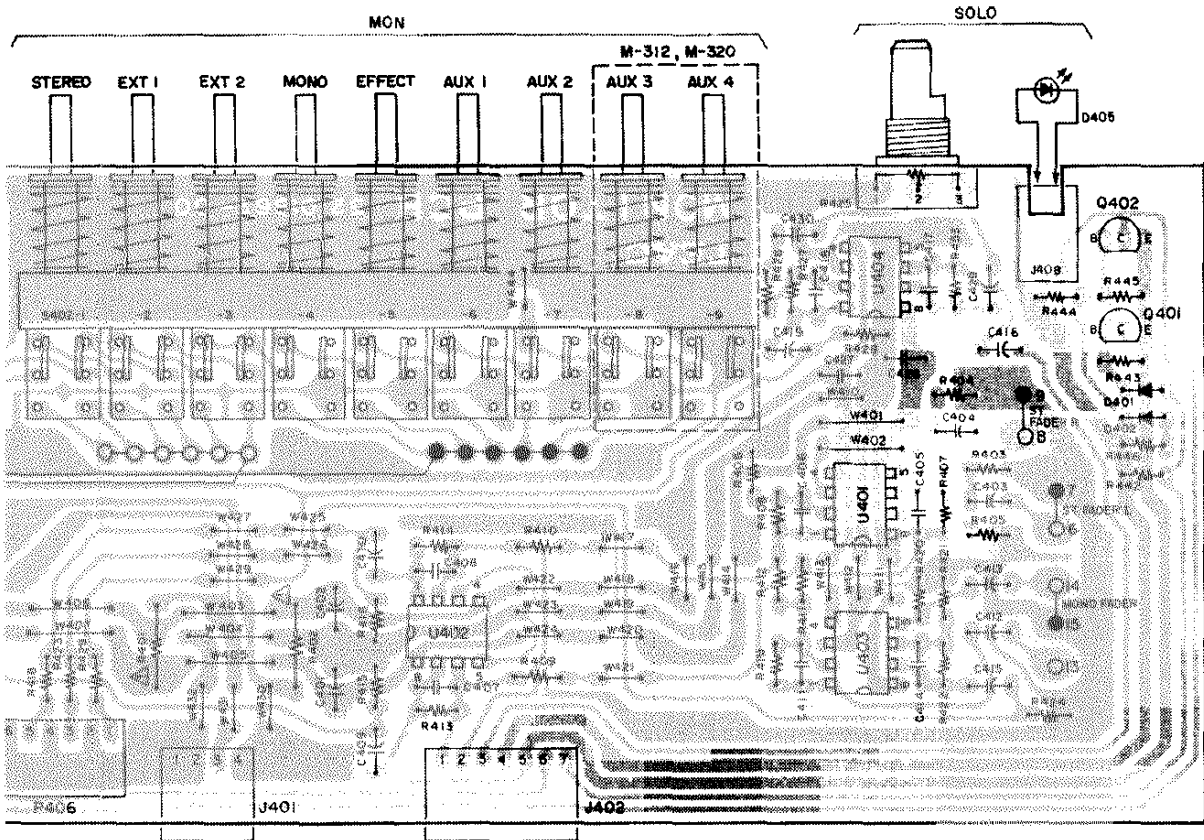

3-13. MON BUSS PCB Ass'y

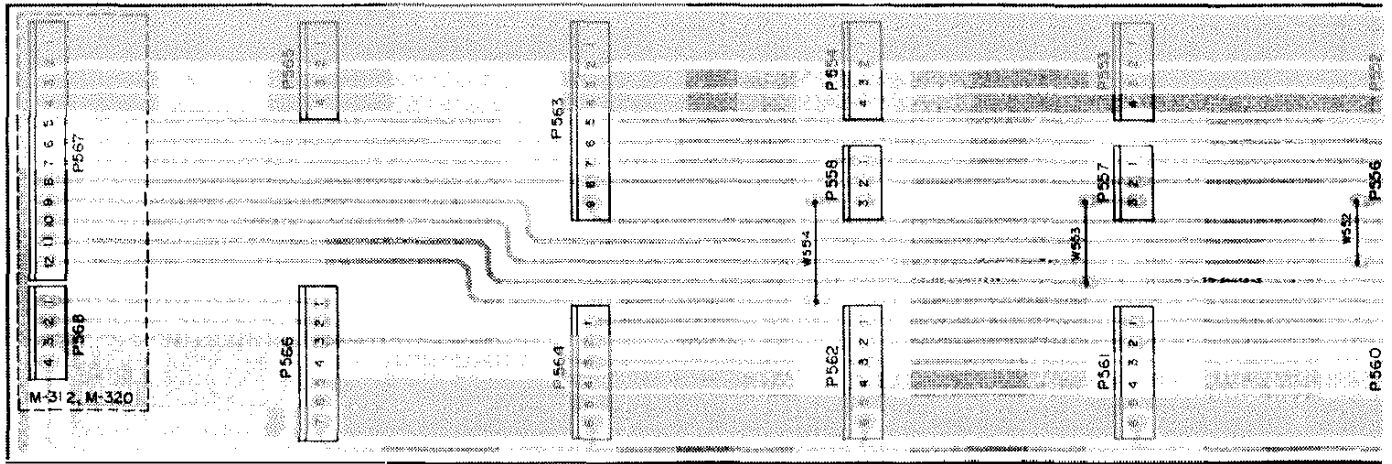

3-14. METER PCB Ass'y

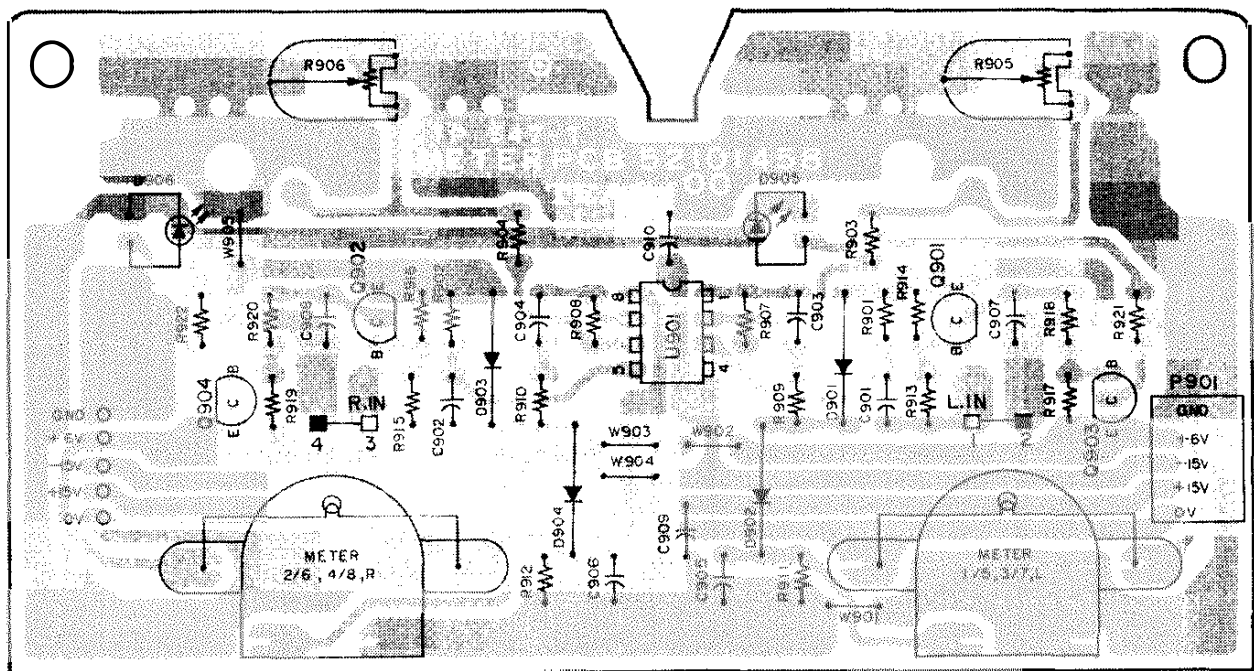

METER PCB Assy 3200143800 : P901 Mounted
 METER PCB Assy 5200145810 : P901 Not mounted

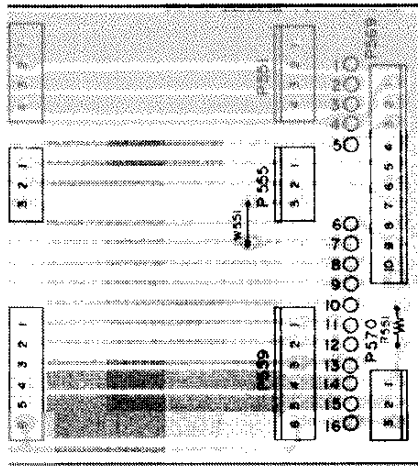

MON BUSS PCB Ass'y

REF. NO.	PARTS NO.	DESCRIPTION	
	5200157200	PCB Ass'y	(M-308)
	5200157210	PCB Ass'y	(M-312, M-320)
	5210157200	PCB	
CONNECTORS			
P551~P654	5336166400	4P (M)	
P555~P558	5336166300	3P (M)	
P559~P562	5336166600	6P (M)	
P563	5336166900	9P (M)	
P564	5336166600	6P (M)	
P565	5336168400	4P (M)	
P566	5336166700	7P (M)	
P567	5336167200	12P (M)	(M-312, M-320)
P568	5336166400	4P (M)	(M-312, M-320)
P569	6336127000	10P (M)	
P570	5336126300	3P (M)	
MISCELLANEOUS			
R651	5240031420	Carbon res. 22k Ω 1/8W 5%	
	5181761000	Jumper wire, 5mm	
	6181762000	Jumper wire, 7.5mm	
	5181763000	Jumper wire, 10mm	
	5181764000	Jumper wire 12.5 mm	

METER PCB Ass'y

REF. NO.	PARTS NO.	DESCRIPTION
	5200145800	PCB Ass'y (P901: Mounted)
	5200145810	PCB Ass'y (P901: Not mounted)
	5210145800	PCB
IC		
U901	5220406700	RC4558P
TRANSISTORS		
Q901, Q902	5230779520	2SC1815 (GR)
Q903, Q904	5145150000	2SA1015 (GR)
DIODES		
D901~D904	5224015400	1k60
D905, D906	5225005400	LED, SLP135B (RED)
CARBON RESISTORS		
All resistors are rated $\pm 5\%$ tolerance 1/6W and of carbon type unless otherwise noted.		
R901, R902	5240033020	100k Ω
R903, R904	5240028420	1.2k Ω
R907, R908	5240030620	10k Ω
R909, R910	5240029020	2.2k Ω
R911, R912	5240028420	1.2k Ω
R913~R916	5240032220	47k Ω
R917~R920	5240030620	10k Ω
R921, R922	5240027220	390 Ω

REF. NO.	PARTS NO.	DESCRIPTION
CAPACITORS		
C901, C902	5260211450	Elec. 2.2 μ F 50V
C903, C904	5260213150	Elec. 22 μ F 25V
C905, C906	5260212950	Elec. 22 μ F 10V
C907, C908	6260211050	Elec. 0.47 μ F 50V
C909, C910	5260212450	Elec. 10 μ F 25V
VARIABLE RESISTORS		
R905, R906	5053446000	Semi-fixed 1k Ω (B)
MISCELLANEOUS		
P901	5336128500	Connector, 5P (M)
	5800606900	Spacer, LED
	5181761000	Jumper wire, 5 mm

3-15. TALKBACK PCB Ass'y (M-312, M-320)

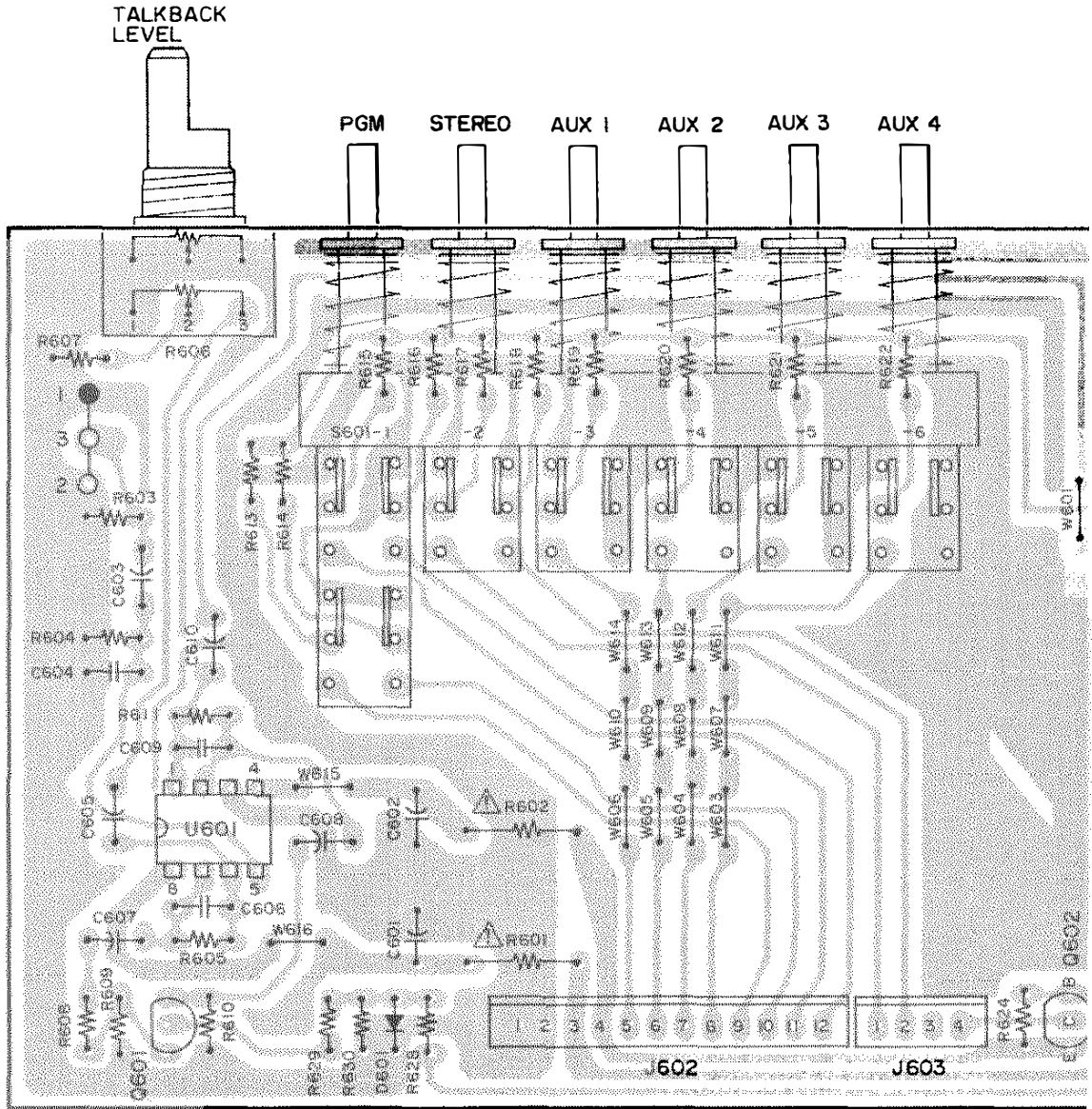

TB PCB Ass'y (M-312, M-320)

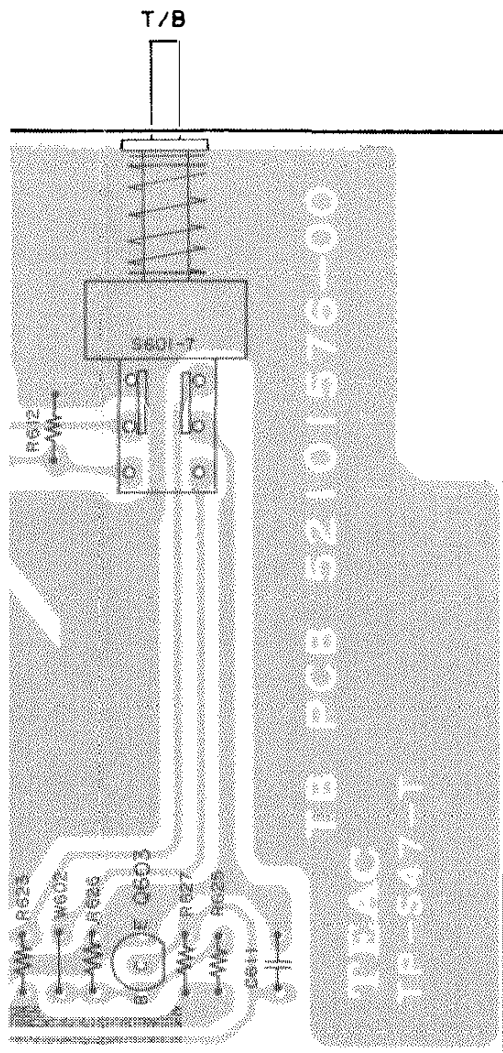

REF. NO.	PARTS NO.	DESCRIPTION
	5200157600	PCB Ass'y
	5210157600	PCB
		IC
U601	5220406700	RC4558P
		TRANSISTORS
Q601	5232007000	2SK304
Q602, Q603	5230779520	2SC1815 (GR)
		DIODE
D601	5224015000	1SS133T77
		CARBON RESISTORS
All resistors are rated $\pm 5\%$ tolerance 1/6W and of carbon type unless otherwise noted.		
R601, R602	5183562000	22 Ω 1/4W Nonflammable
R603	5240033020	100k Ω
R604	5240030820	10k Ω
R605	5240033020	100k Ω
R607	5240028220	1k Ω
R608	5240030620	10k Ω
R609	5240029820	4.7k Ω
R610	5240033020	100k Ω
R611	5240031820	33k Ω
R612	5240033020	100k Ω
R613~R616	5240031420	22k Ω
R617, R618	5240030620	10k Ω
R619, R622	5240031420	22k Ω
R623~R628	5240033020	100k Ω
R629	5240036220	2.2M Ω
R630	5240033020	100k Ω
		CAPACITORS
C601, C602	5260162650	Elec. 10 μ F 25V
C603	5260162550	Elec. 10 μ F 16V
C604	5173455000	Ceramic 68pF
C605	5260165052	Elec. 47 μ F 10V
C606	5173449000	Ceramic 22pF
C607	5260162650	Elec. 10 μ F 25V
C608	5260162550	Elec. 10 μ F 16V
C609	5173453000	Ceramic 47pF
C610	5260165252	Elec. 47 μ F 25V
C611	5173433000	Ceramic 0.01 μ F
		VARIABLE RESISTOR
R606	5262410400	50k Ω (RD) x 2
		MISCELLANEOUS
J602	5336165200	Connector, 12P (F)
J603	5336164400	Connector, 4P (F)
S601	5300039600	Push sw. ((4C + 5 x 2C) -L + 2C -NL) -NS
	5181761000	Jumper wire, 5mm
	5800663300	Support, PCB
	5781023008	Screw, Pan head tapping M3 x 8

3-16. JACK A PCB Ass'y

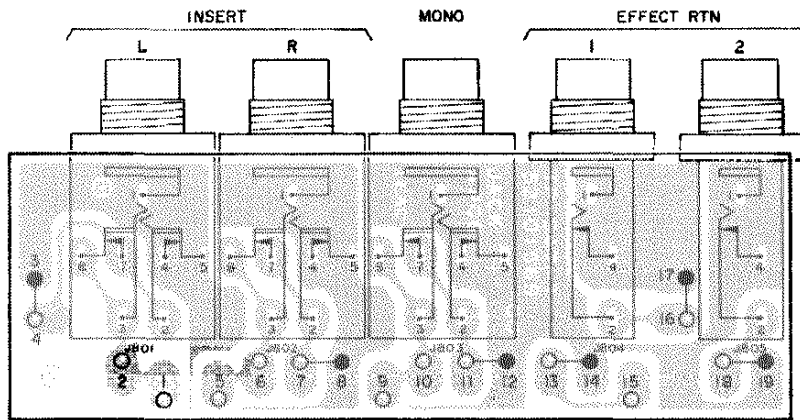

3-17. JACK B PCB Ass'y

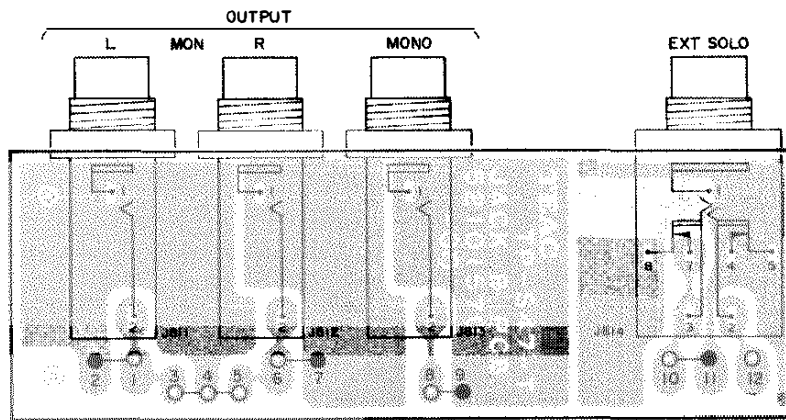

3-18. JACK C PCB Ass'y

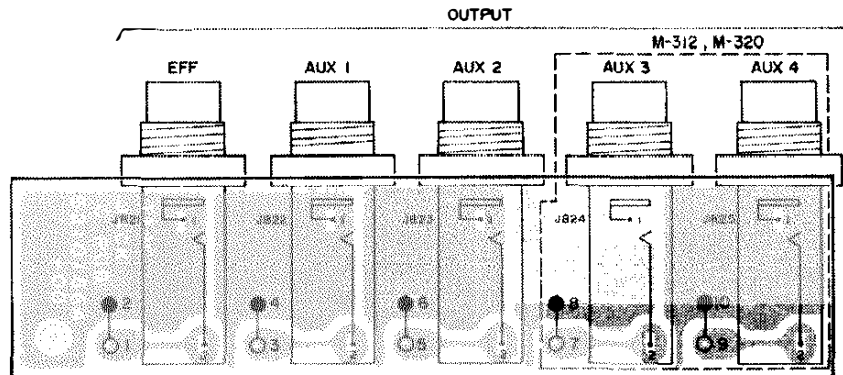

JACK A PCB Ass'y

REF. NO.	PARTS NO.	DESCRIPTION
	5200156900	PCB Ass'y
	5210156900	PCB
J801~J803	5330011400	1/4" Jack (TRS)
J804, J805	5330010800	1/4" Jack (SW)

TB MIC PCB Ass'y (M-312, M-320)

REF. NO.	PARTS NO.	DESCRIPTION
	5200157700	PCB Ass'y
	5210157700	PCB
J601	5334041400	XLB (F)
	5781012605	Screw, Pan head, Tapping M2.6 x 5

JACK B PCB Ass'y

REF. NO.	PARTS NO.	DESCRIPTION
	5200157000	PCB Ass'y
	5210157000	PCB
J811~J813	5330011500	1/4" Jack
J814	5330011400	1/4" Jack (TRS)

TR PCB Ass'y (A)

REF. NO.	PARTS NO.	DESCRIPTION
	5200145600	PCB Ass'y
	5210145600	PCB
	5230017700	Transistor, 2SA1264(0)

JACK C PCB Ass'y

REF. NO.	PARTS NO.	DESCRIPTION
	5200156400	PCB Ass'y (M-308)
	5200156410	PCB Ass'y (M-312, M-320)
	5210156400	PCB
J821~J823	5330011500	1/4" Jack
J824, J825	5330011500	1/4" Jack (M-312, M-320)

TR PCB Ass'y (B)

REF. NO.	PARTS NO.	DESCRIPTION
	5200145610	PCB Ass'y
	5210145600	PCB
	5230779400	Transistor, 2SC3181(0)

SUB IN PCB Ass'y

REF. NO.	PARTS NO.	DESCRIPTION
	5200156300	PCB Ass'y (M-308)
	5200156310	PCB Ass'y (M-312, M-320)
	5210156300	PCB
CARBON RESISTORS		
All resistors are rated $\pm 5\%$ tolerance 1/6W and of carbon type unless otherwise noted.		
RB61~RB69	5240031420	22k Ω
RB70, RB71	5240031420	22k Ω (M-312, M-320)
CONNECTORS		
J861	5330507200	RCA jack, 4P
J862	5330507300	RCA jack, 6P
J862, J863	5330507200	RCA jack, 4P (M-312, M-320)
J864	5330507200	RCA jack, 4P

3-19. SUB IN PCB Ass'y

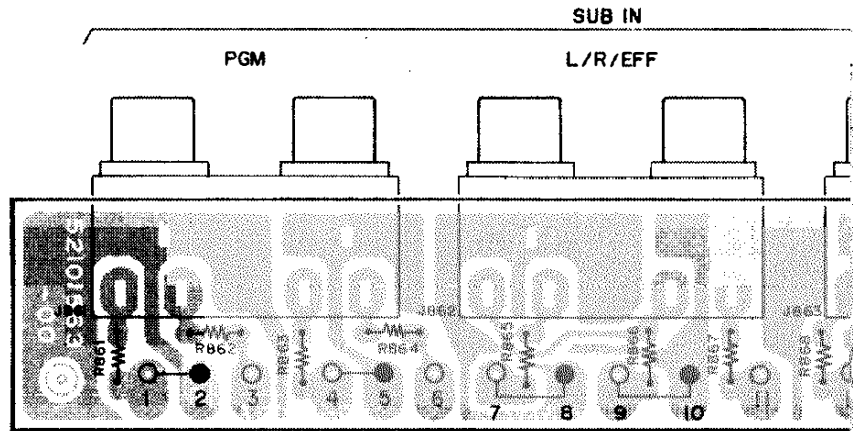

3-20. TB MIC PCB Ass'y (M-312, M320)

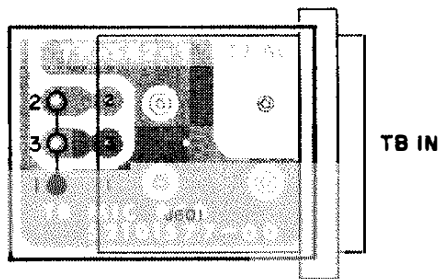

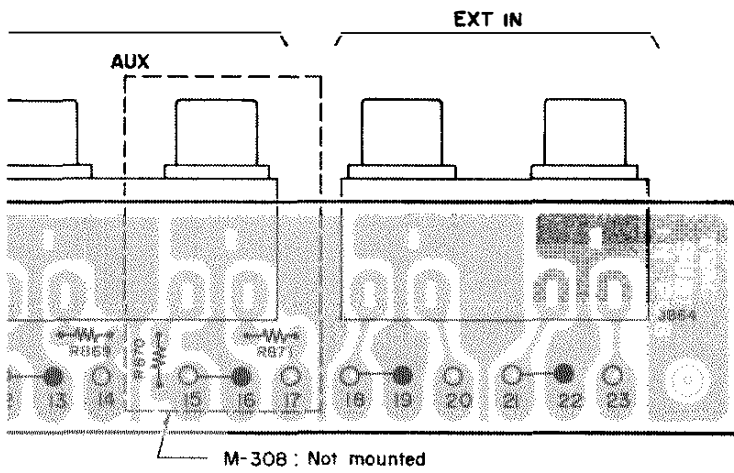

3-21. TR PCB Ass'y (A)

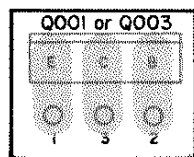

3-22. TR PCB Ass'y (B)

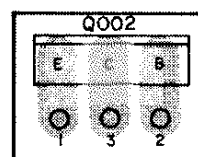

3-23. POWER SUPPLY PCB Ass'y

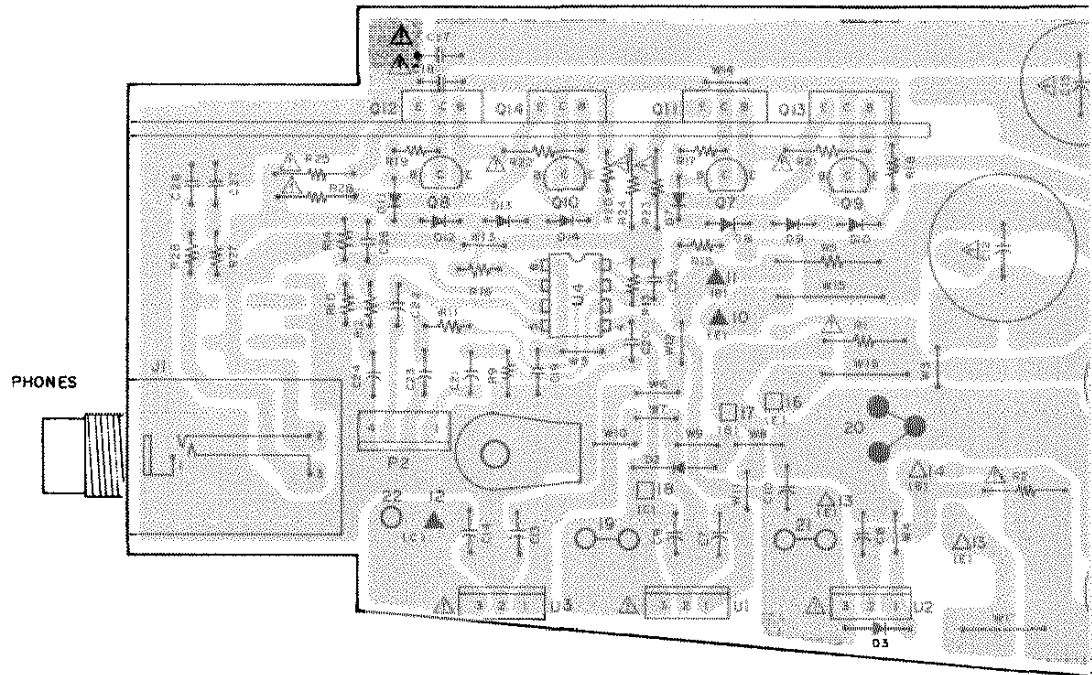

3-24. SW PCB Ass'y (PCB Omitted)

REF. NO.	PARTS NO.	DESCRIPTION	
	5200145400	PCB Ass'y	[J, GE]
	5200145410	PCB Ass'y	[US]
	5200145420	PCB Ass'y	[C]
	5200145430	PCB Ass'y	[E, UK, A]
	5210145400	PCB	
		SPARK KILLERS	
Z001	△5052907000	0.01μF + 300Ω/300V	[J, GE]
Z001	△5052910000	0.033μF + 120Ω/125V	[US]
Z001	△5292002600	0.033μF + 120Ω/125V	[C]
Z001, Z002	△5267702500	0.0047μF/250V	[E, UK, A]
		SWITCH	
S001	5300030900	SDL-1P	
		MISCELLANEOUS	
	5327007200	Terminal, Lapping; 2P	[E, UK, A]

[US]: U.S.A.
[C]: CANADA
[GE]: GENERAL EXPORT
[A]: AUSTRALIA
[E]: EUROPE
[UK]: U.K.
[L]: LIMITED AREA
[J]: JAPAN

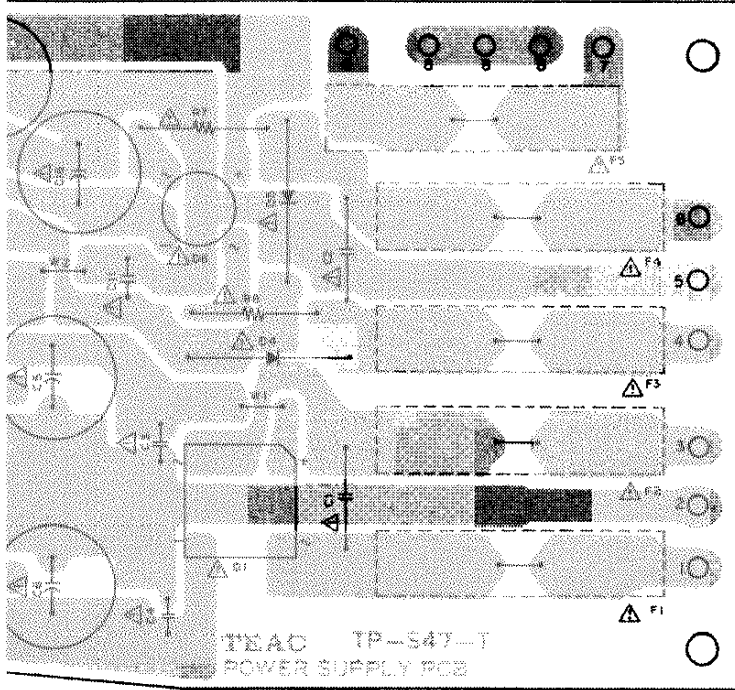

POWER SUPPLY PCB Ass'y

REF. NO.	PARTS NO.	DESCRIPTION
	5200155300	PCB Ass'y [J, GE] (M-308)
	5200155310	PCB Ass'y [US, C] (M-308)
	5200155320	PCB Ass'y [E, UK, A] (M-308)
	5200157400	PCB Ass'y [J, GE] (M-312)
	5200157410	PCB Ass'y [US, C] (M-312)
	5200157420	PCB Ass'y [E, UK, A] (M-312)
	5200158100	PCB Ass'y [J, GE] (M-320)
	5200158110	PCB Ass'y [US, C] (M-320)
	5200158120	PCB Ass'y [E, UK, A] (M-320)
	5210155300	PCB (M-308)
	5210157400	PCB (M-312)
	5210158100	PCB (M-320)
IC's		
U001	△ 5220413100	NJM78M15A
U002	△ 5220420500	NJM79M15A
U003	△ 5220411000	NJM78M06A
U004	5220411100	NJM4560DX
TRANSISTORS		
Q007, Q008	5230779520	2SC1815 (GR)
Q009, Q010	5230750000	2SA1015 (GR)
Q011, Q012	5230780600	2SC2877 (O)
Q013, Q014	5230018500	2SA1217 (O)
DIODES		
D001	△ 5228005900	KBPC-602
D002, D003	5143089000	W03C
D004, D005	△ 5143016000	U05B
D006	△ 5228005000	W02
D007~D014	5224015000	1S133T77
CARBON RESISTORS		
All resistors are rated ±5% tolerance 1/6W and of carbon type unless otherwise noted.		
R001, R002	△ 5183582000	150Ω 1/4W Nonflammable
R005	△ 5183582000	150Ω 1/4W Nonflammable
R007, R008	△ 5185648000	2.2Ω 1/2W Nonflammable
R009, R010	5240032220	47kΩ 1/BW
R011, R012	5240028220	1kΩ 1/BW
R013, R014	5240030820	12kΩ 1/BW
R015, R016	5240027420	470Ω 1/BW
R017, R020	5240029220	2.7kΩ 1/BW
R021, R022	△ 5183586000	220Ω 1/4W Nonflammable
R023~R026	△ 5183530000	1Ω 1/4W Nonflammable
R027, R028	5240021820	2.2Ω 1/BW
CAPACITORS		
C001, C002	△ 5263164500	Meta. 0.047μF 250V
C003, C004	△ 5173433000	Ceramic 0.01μF
C005, C006	△ 5173090000	Elec. 2200μF 35V (M-308)
C005, C006	△ 5260091600	Elec. 3300μF 35V (M-313, M-320)
C007, C008	5260161150	Elec. 2.2μF 50V
C009, C010	5260165252	Elec. 47μF 25V
C011	△ 5173433000	Ceramic 0.01μF
C012	△ 5260092700	Elec. 6800μF 16V (M-308, M-312)
C012	△ 5260093200	Elec. 10000μF 16V (M-320)

REF. NO.	PARTS NO.	DESCRIPTION
C013	5260161150	Elec. 2.2μF 50V
C014	5260165052	Elec. 47μF 10V
C015, C016	△ 5173088000	Elec. 2200μF 16V
C017, C018	△ 5173433000	Ceramic 0.01μF
C019, C020	5173433000	Ceramic 0.01μF
C021, C022	5260162550	Elec. 10μF 16V
C023, C024	5260165052	Elec. 47μF 10V
C025, C026	5173453000	Ceramic 47pF
C027, C028	5263167423	Meta. 0.039μF
FUSES (M-308)		
F001~F004	△ 5307004100	2A/250V [US, C, J, GE]
F001~F004	△ 5142189000	T2A/250V [E, UK, A]
FUSES (M-312)		
F001, F002	△ 5307021200	2.5A/250V Slow blow [US, C, J, GE]
F001, F002	△ 5142190000	T2.5A/250V [E, UK, A]
F003, F004	△ 5307021600	4A/250V Slow blow [US, C, J, GE]
F003, F004	△ 5142192000	T4A/250V [E, UK, A]
F005	△ 5307020400	1A/250V Slow blow [US, C, J, GE]
F005	△ 5041140000	T1A/250V [E, UK, A]
FUSES (M-320)		
F001~F004	△ 5307021600	4A/250V Slowblow [US, C, J, GE]
F001~F004	△ 5142192000	T4A/250V [E, UK, A]
F005	△ 5307021000	2A/250V Slow blow [US, C, J, GE]
F005	△ 5142189000	T2A/250V [E, UK, A]
MISCELLANEOUS		
J001	5330010401	Jack, PHONES
P002	5336126400	Connector, 4P
	5041237000	Holder, Fuse, Normal [US, C, J, GE]
	5332014200	Holder, Fuse, Mini. [E, UK, A]
	5555590000	Earth plate
	5800607500	Heatsink
	5033291000	Plata, Insul. 1S-313D
	5033295000	Tuba, Insul.
	5788102000	Tube, NL 0.85 x 1.45 x 10
	5800663500	Blackat, Jack
	5780103008	Screw, Panhead M3 x 8
	5181761000	Jumper wire, 5 mm
	5181763000	Jumper wire, 10 mm

[US]: U.S.A.
 [C]: CANADA
 [GE]: GENERAL EXPORT
 [A]: AUSTRALIA
 [E]: EUROPE
 [UK]: U.K.
 [L]: LIMITED AREA
 [J]: JAPAN

3-25. RIAA PCB Ass'y (M-308) (Japan Model Only)

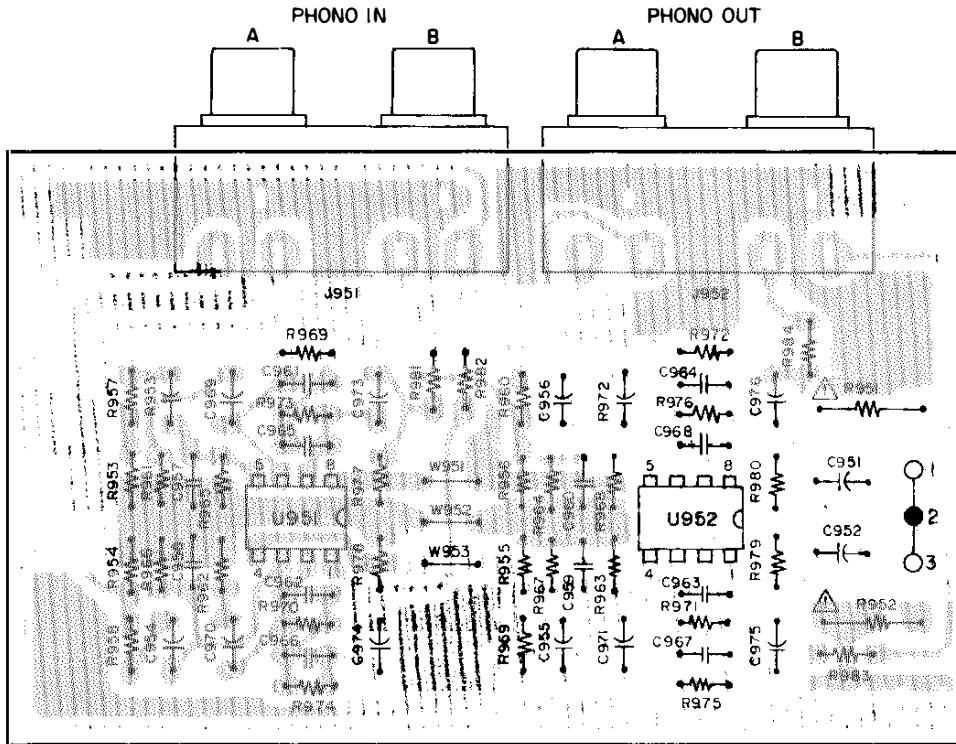

RIAA PCB Ass'y (M-308) (Japan Model Only)

REF. NO.	PARTS NO.	DESCRIPTION
	5200163600	PCB Ass'y
	5210163600	PCB
		IC's
U951, U952	5220416600	NJM2041DD
		CARBON RESISTORS
All resistors are rated $\pm 5\%$ tolerance 1/6W and of carbon type unless otherwise noted.		
R951, R952	Δ 5183562000	22 Ω 1/4W Nonflammable
R953~R956	5240034620	470k Ω
R957~R960	5240025820	100 Ω
R961~R964	5240026420	180 Ω
R965~R968	5240032220	47k Ω
R969~R972	5240034020	270k Ω
R973~R976	5240031420	22k Ω
R977~R980	5240033020	100k Ω
R981~R984	5240025820	100 Ω

REF. NO.	PARTS NO.	DESCRIPTION
		CAPACITORS
C951, C952	5260165252	Elec. 47 μ F 25V
C953~C956	5260162550	Elec. 10 μ F 16V
C957~C960	5172210000	Ceramic 68pF
C961~C964	5171858000	Poly. 0.012 μ F
C965~C968	5170364000	Poly. 0.0033 μ F
C969~C972	5173054800	Elec. 220 μ F 6.3V
C973~C976	5260162650	Elec. 10 μ F 25V
		MISCELLANEOUS
J951, J952	5330507200	Pin jack, 4P

4. SCHEMATIC DIAGRAMS

4-1. WIRING DIAGRAM (M-308)

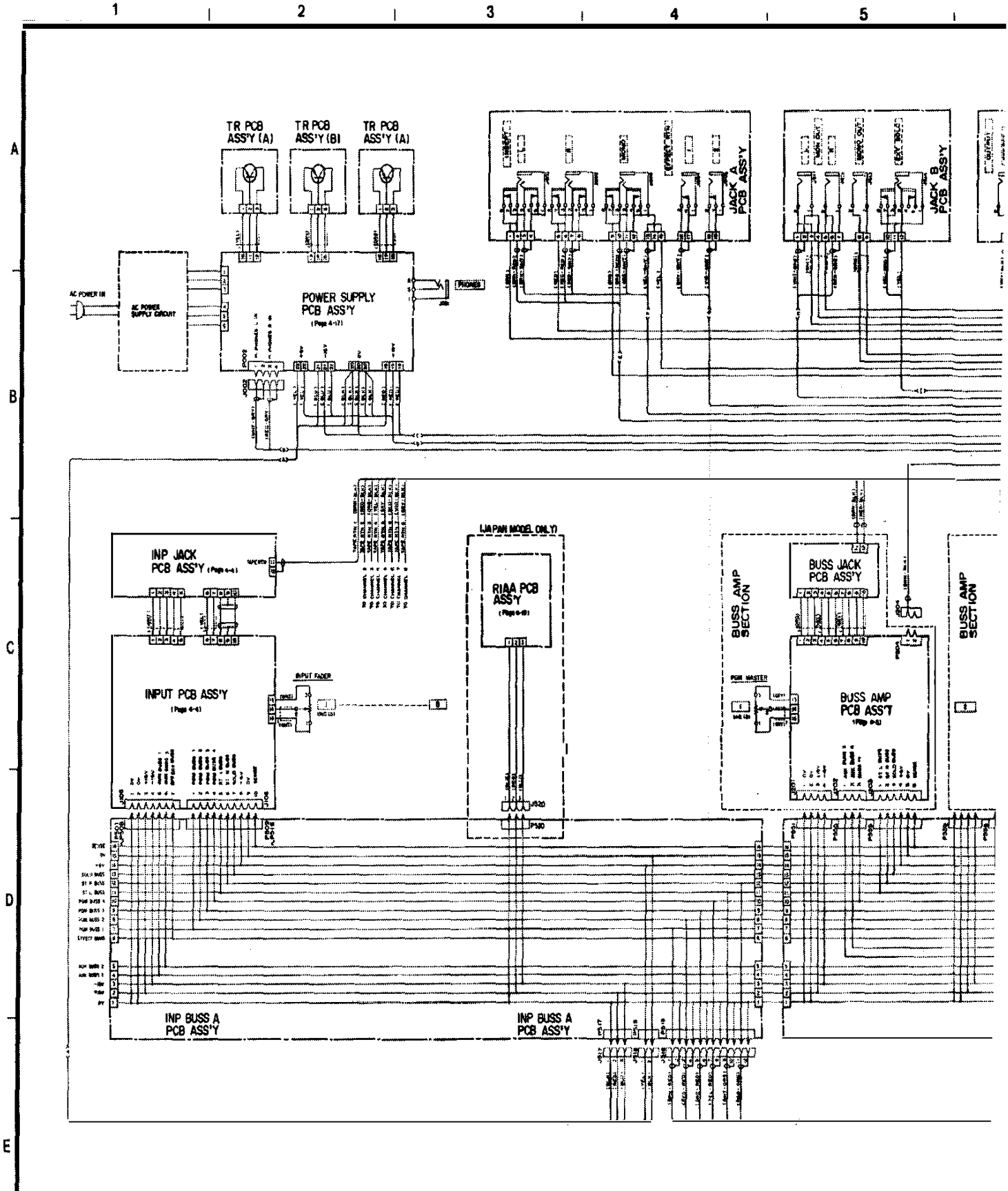

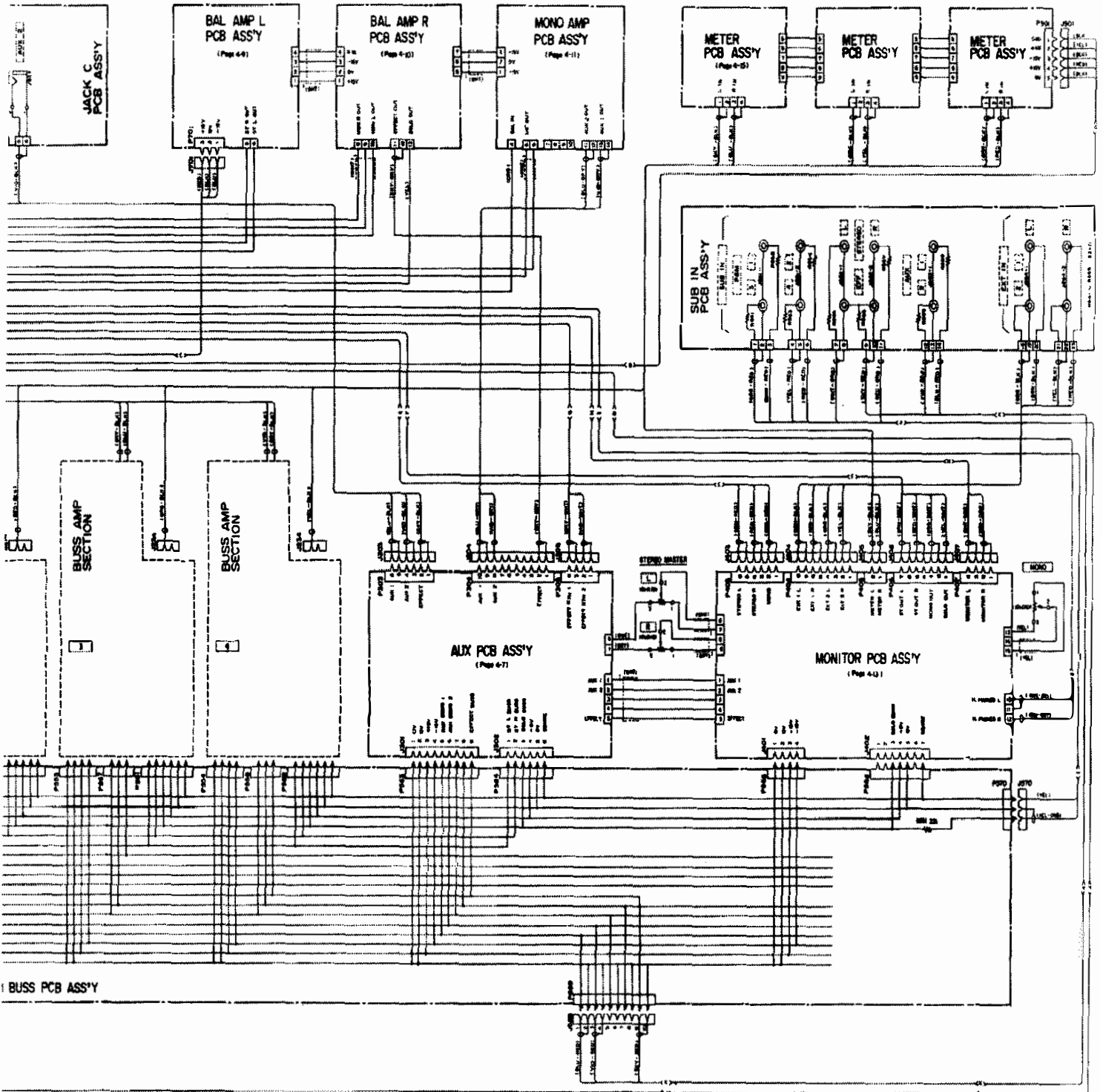

4-2. WIRING DIAGRAM (M-312)

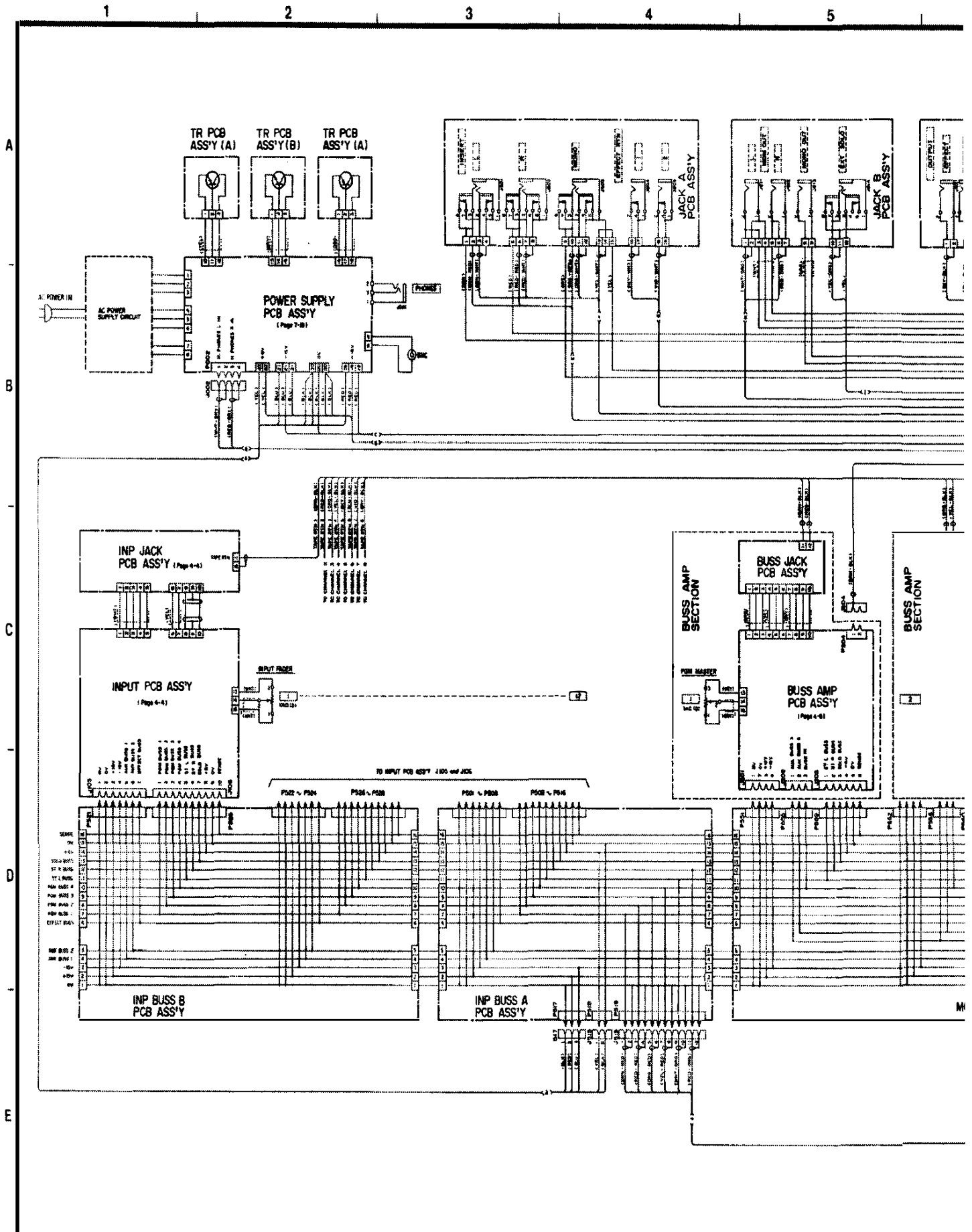

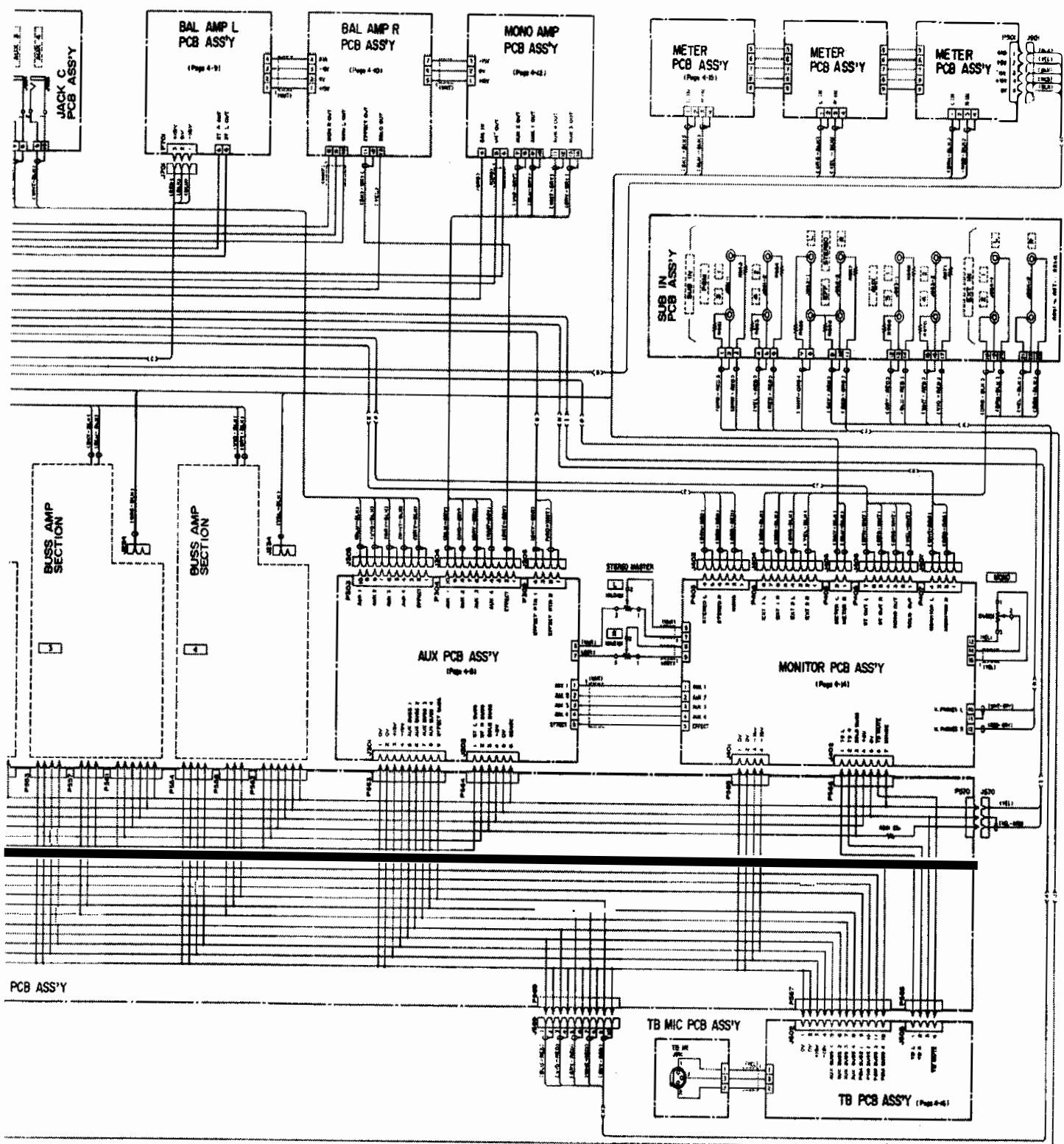

4-3. WIRING DIAGRAM (M-320)

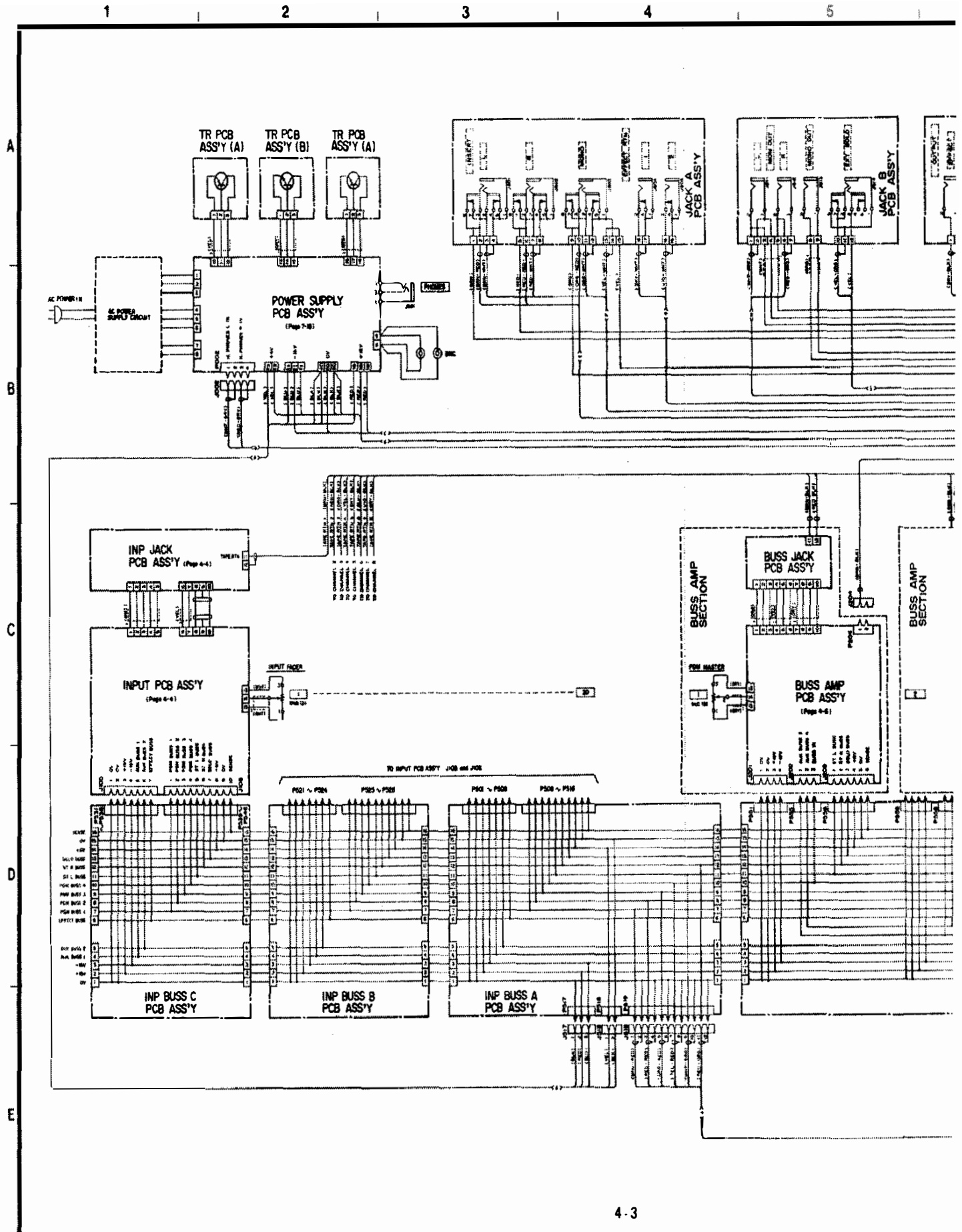

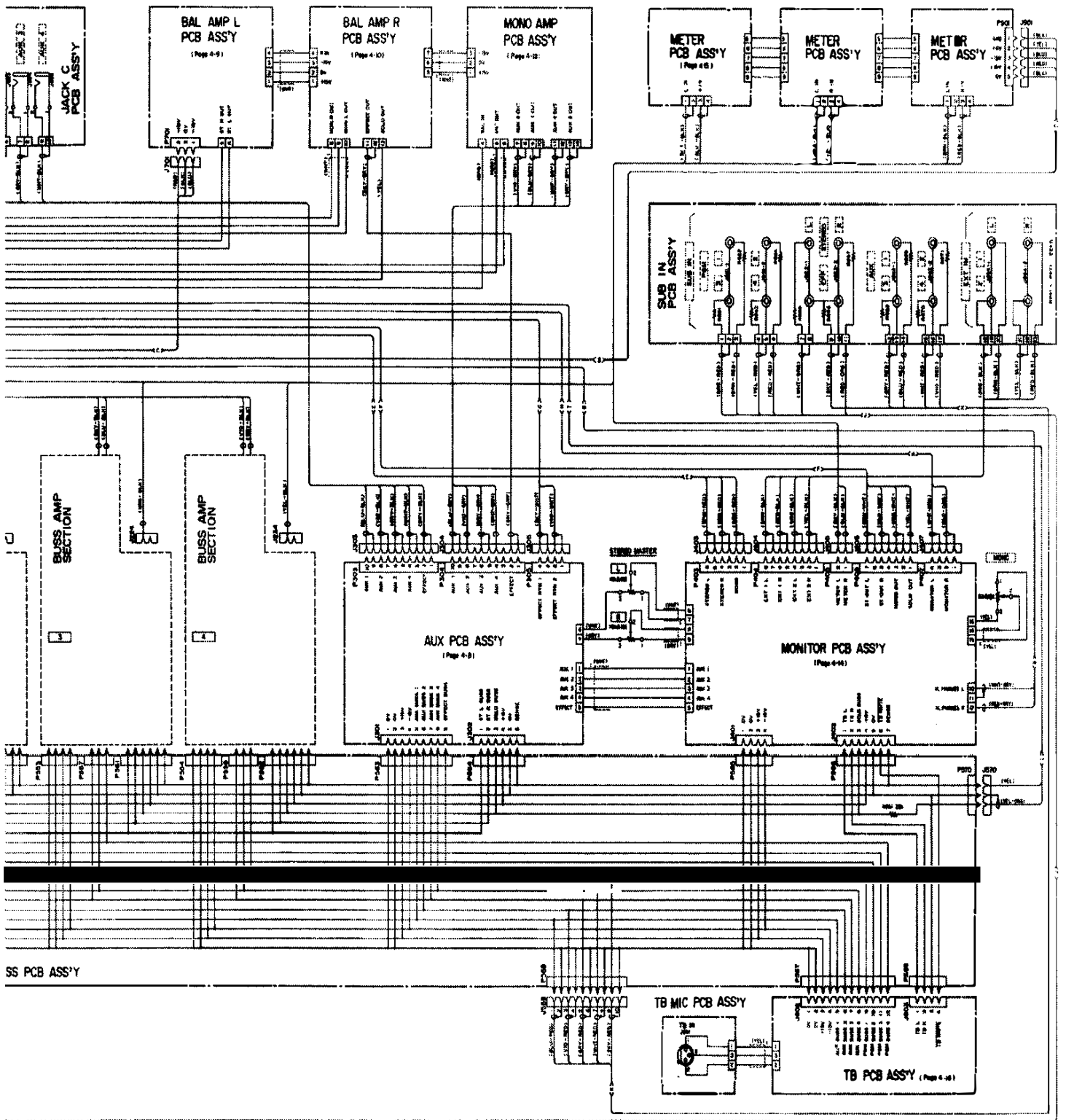

4-4. INPUT PCB ASS'Y

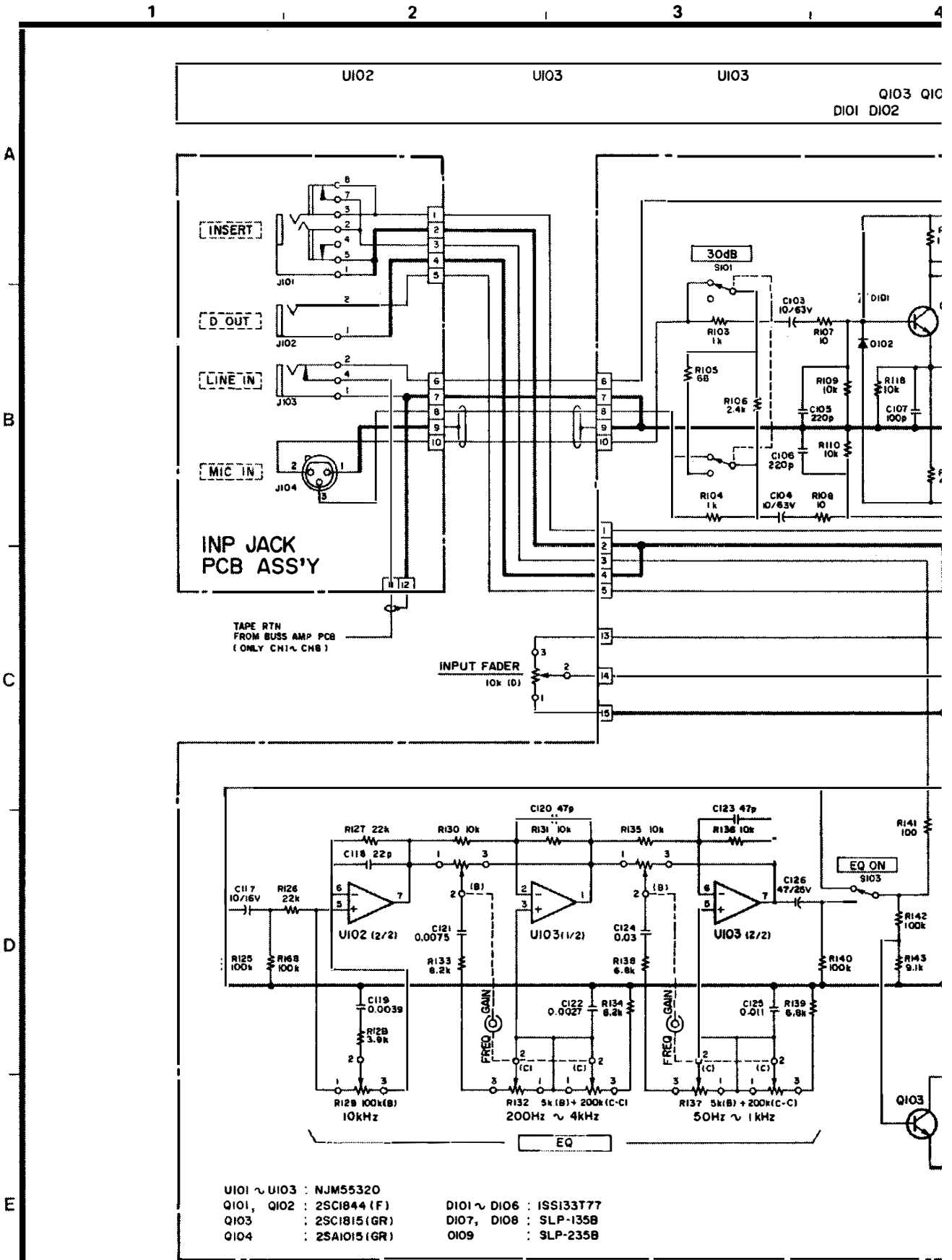

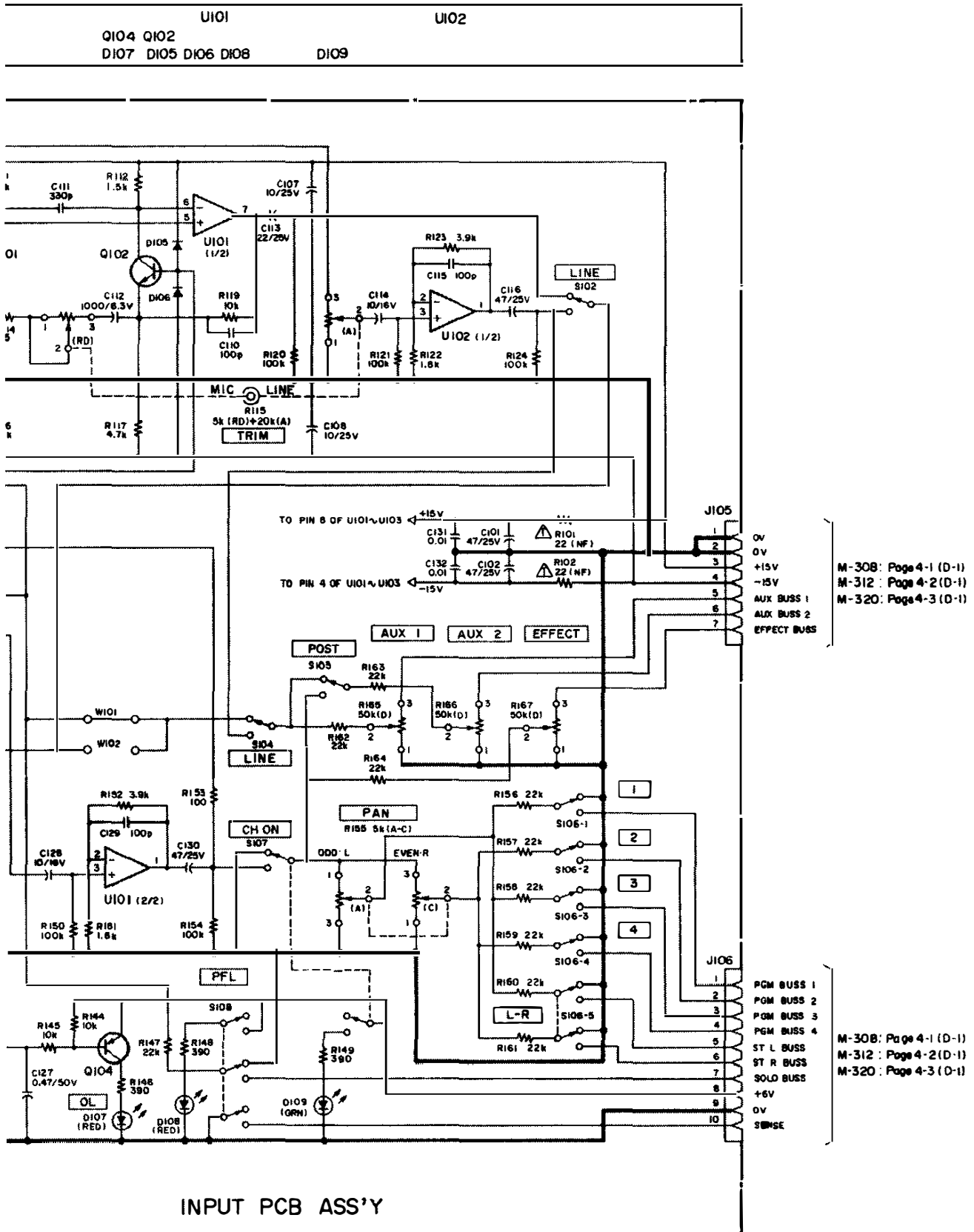

M-308: Page 4-1 (D-1)
M-312: Page 4-2 (D-1)
M-320: Page 4-3 (D-1)

M-308: Page 4-1 (D-1)
M-312: Page 4-2 (D-1)
M-320: Page 4-3 (D-1)

4-5. BUSS AMPLIFIER PCB ASS'Y (M-308)

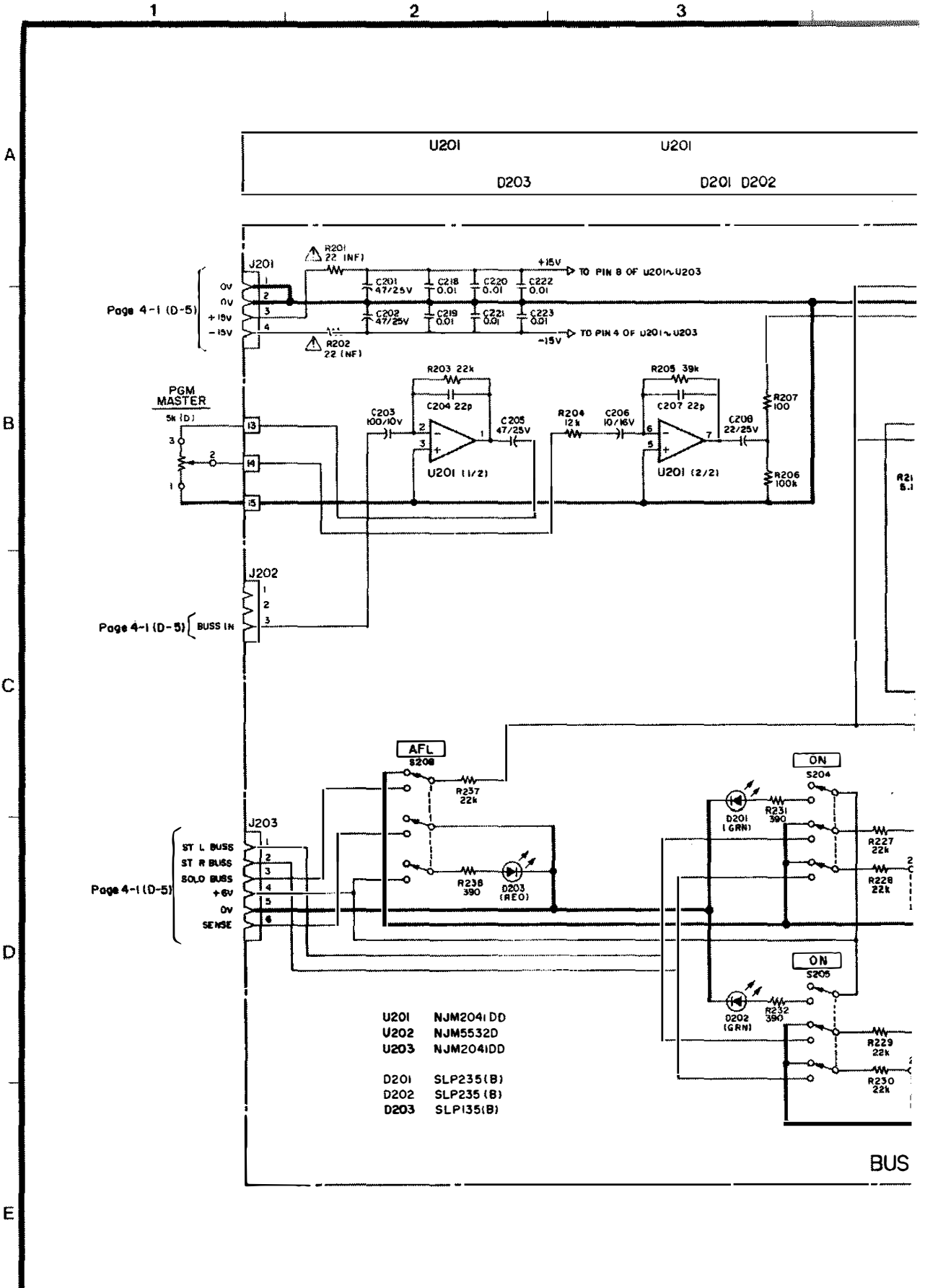

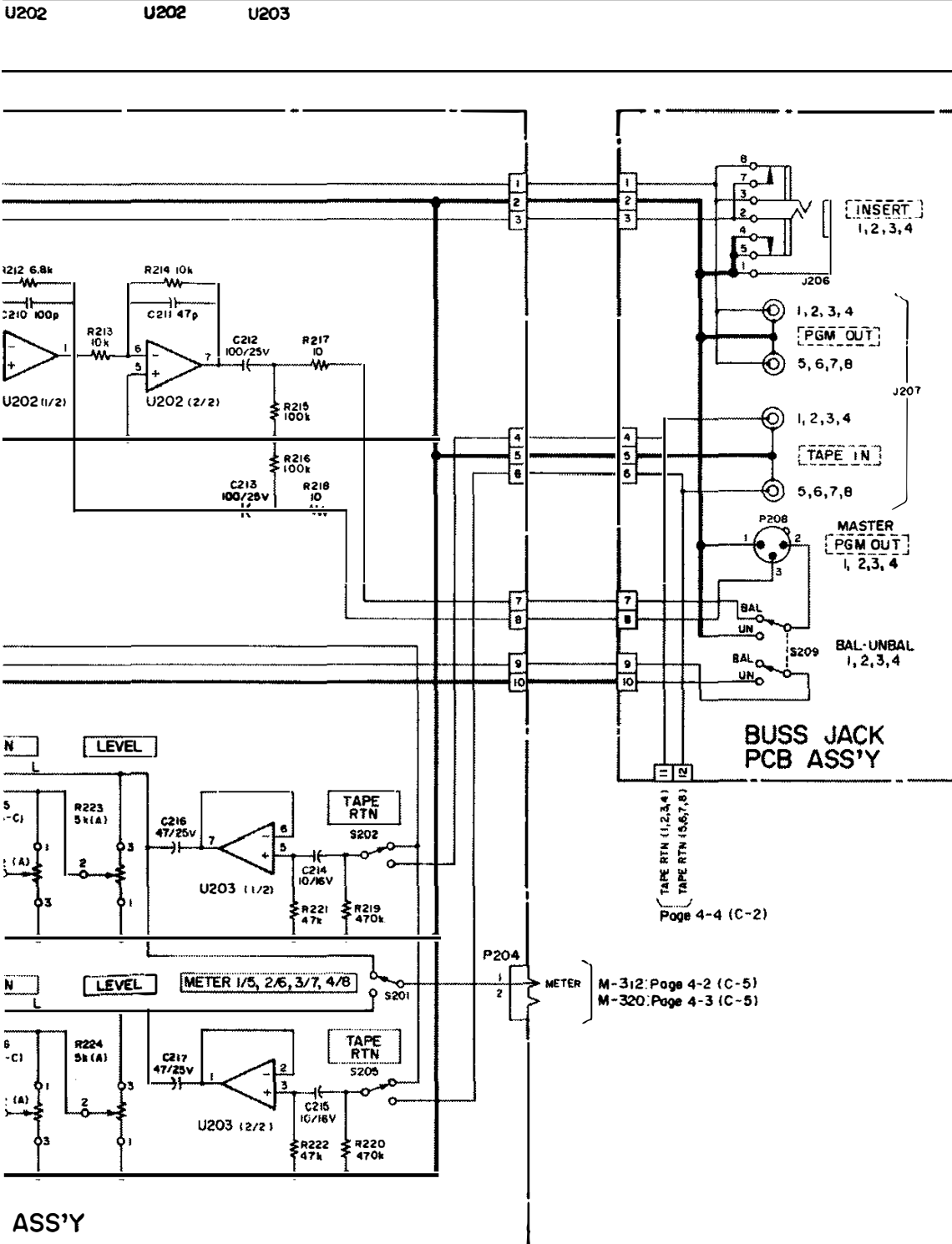

4-7. AUXILIARY PCB ASS'Y (M-308)

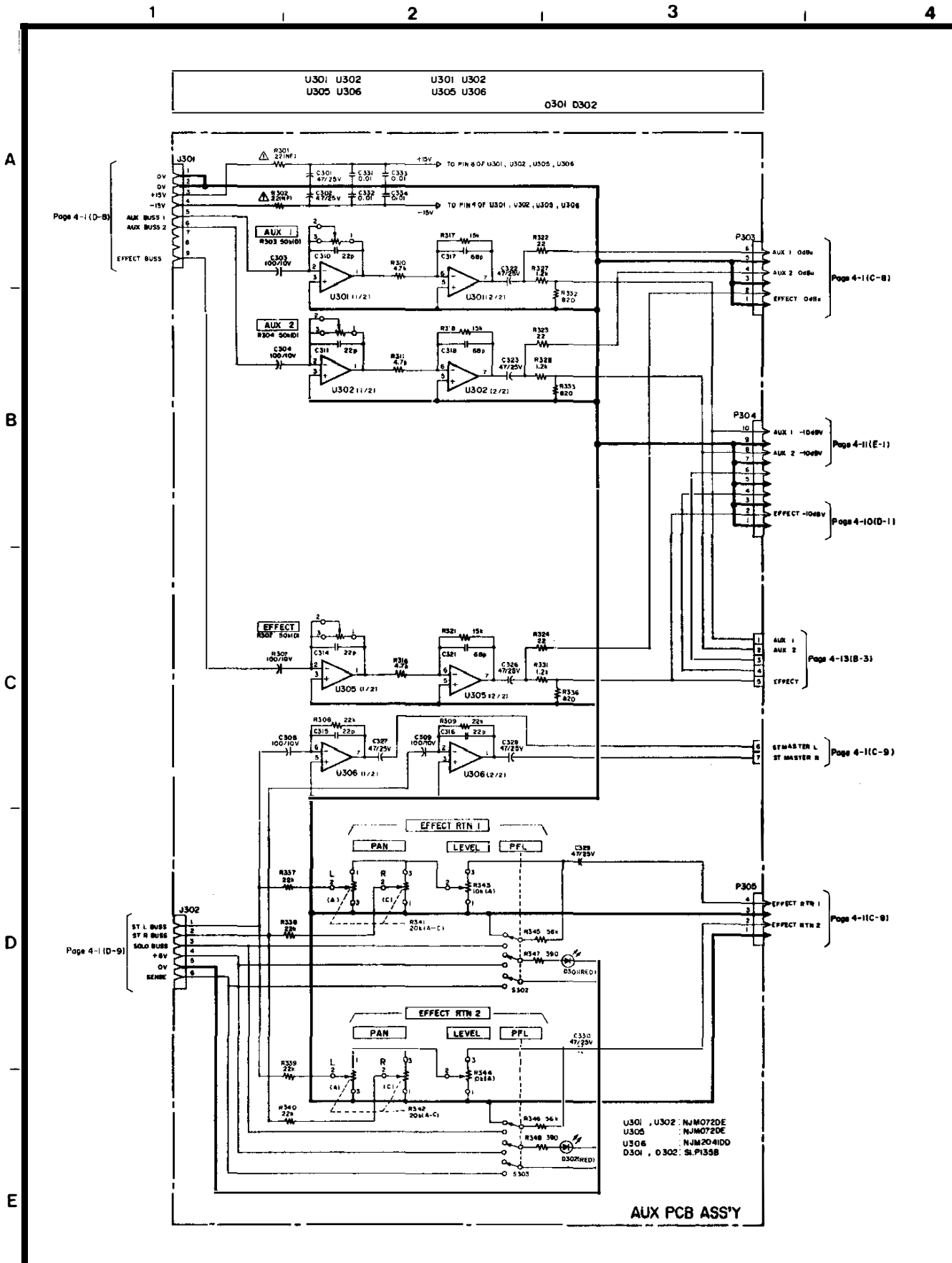

4-8. AUXILIARY PCB ASS'Y (M-312/M-320)

1 2 3 4

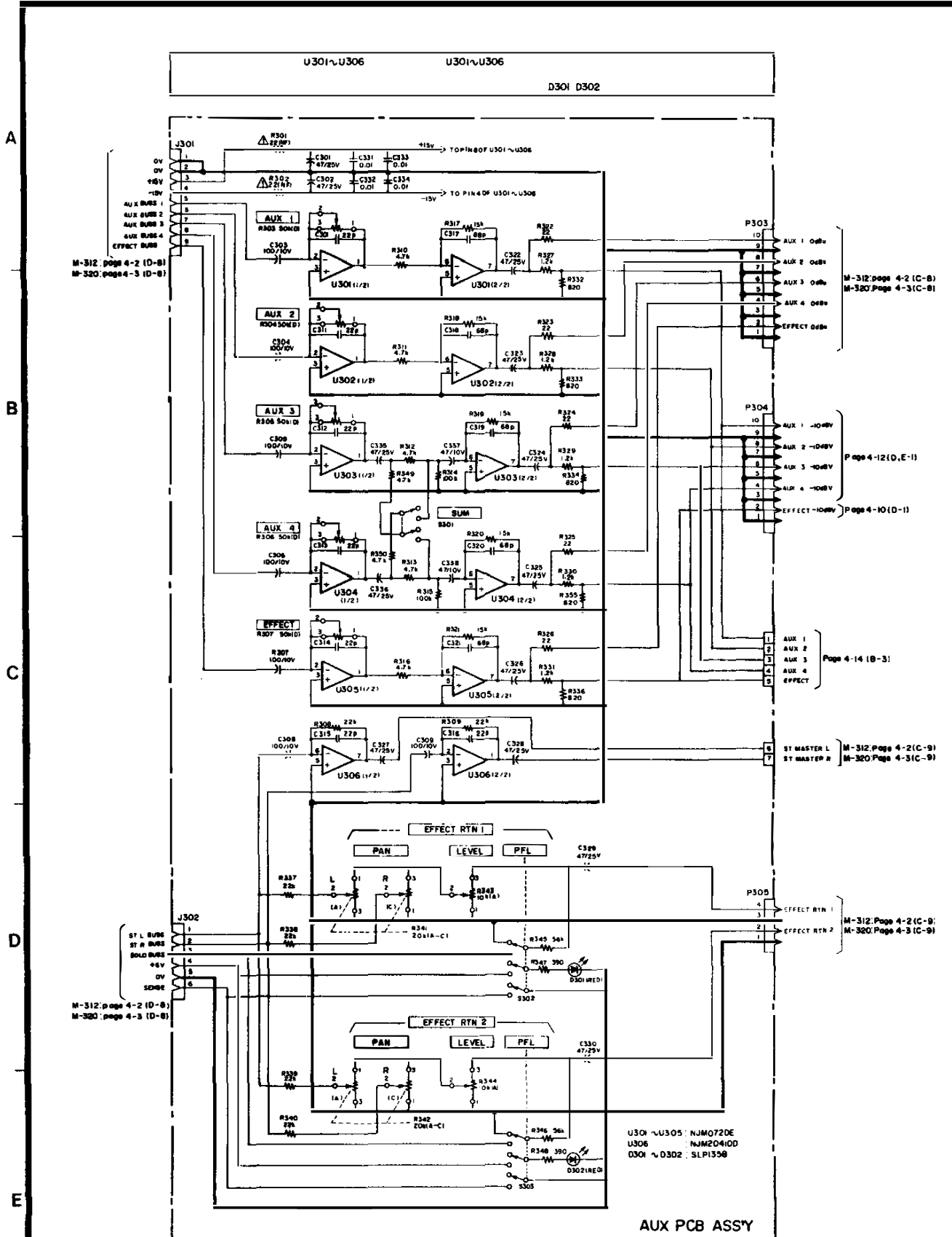

4-9. BALANCED AMPLIFIER L PCB ASS'Y

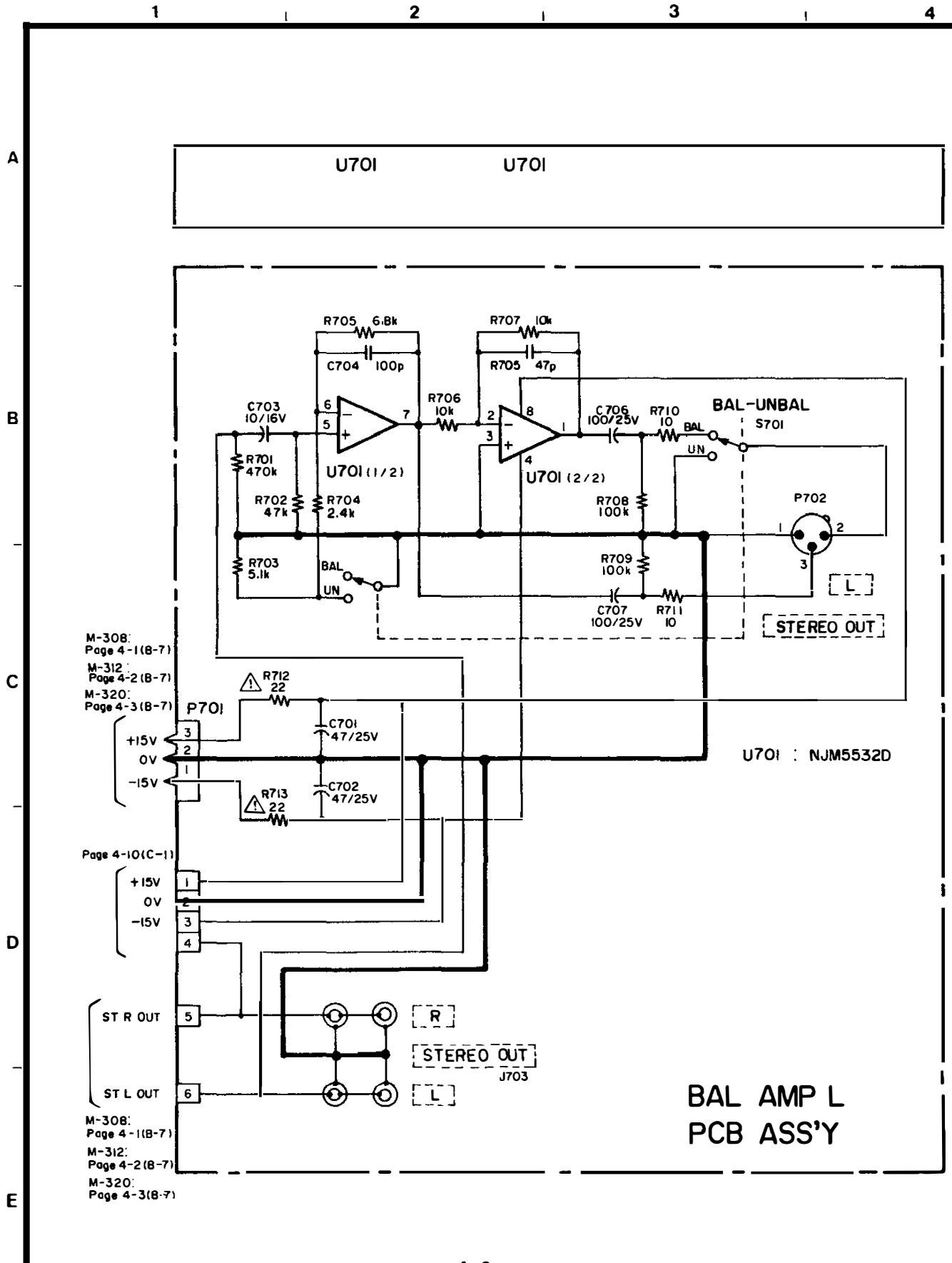

4-10. BALANCED AMPLIFIER R PCB ASS'Y

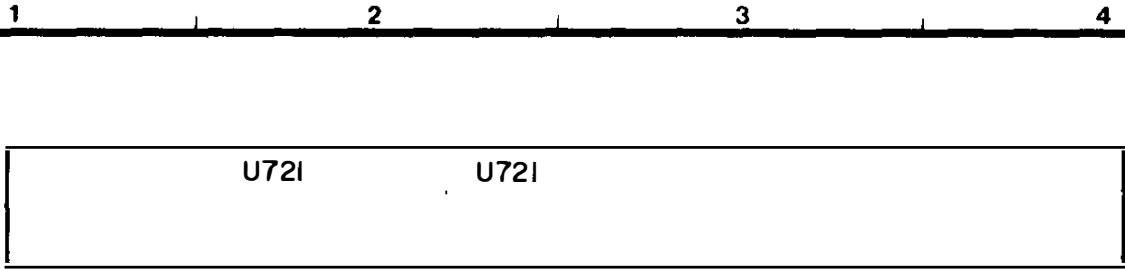

M-308:
Page 4-11(D-1)
M-312:
Page 4-12(D-1)
M-320:
Page 4-12(D-1)

Page 4-9
(D-1)

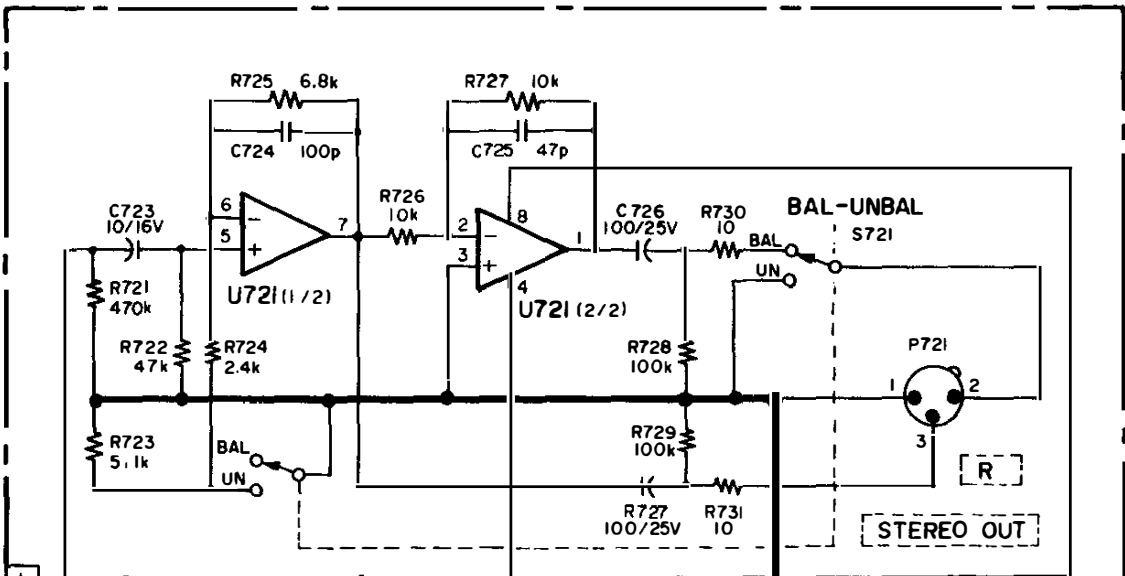

U721 : NJM5532D

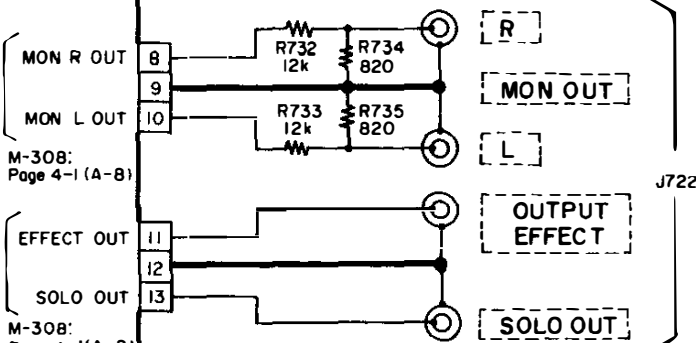

M-308:
Page 4-1(A-8)

M-308:
Page 4-1(A-8)

M-312:
Page 4-2(A-8)

M-320:
Page 4-3(A-8)

BAL AMP R
PCB ASS'Y

4-11. MONO AMPLIFIER PCB ASS'Y (M-308)

1 2 3 4

A
B
C
D
E

U741 U742 U741 U742

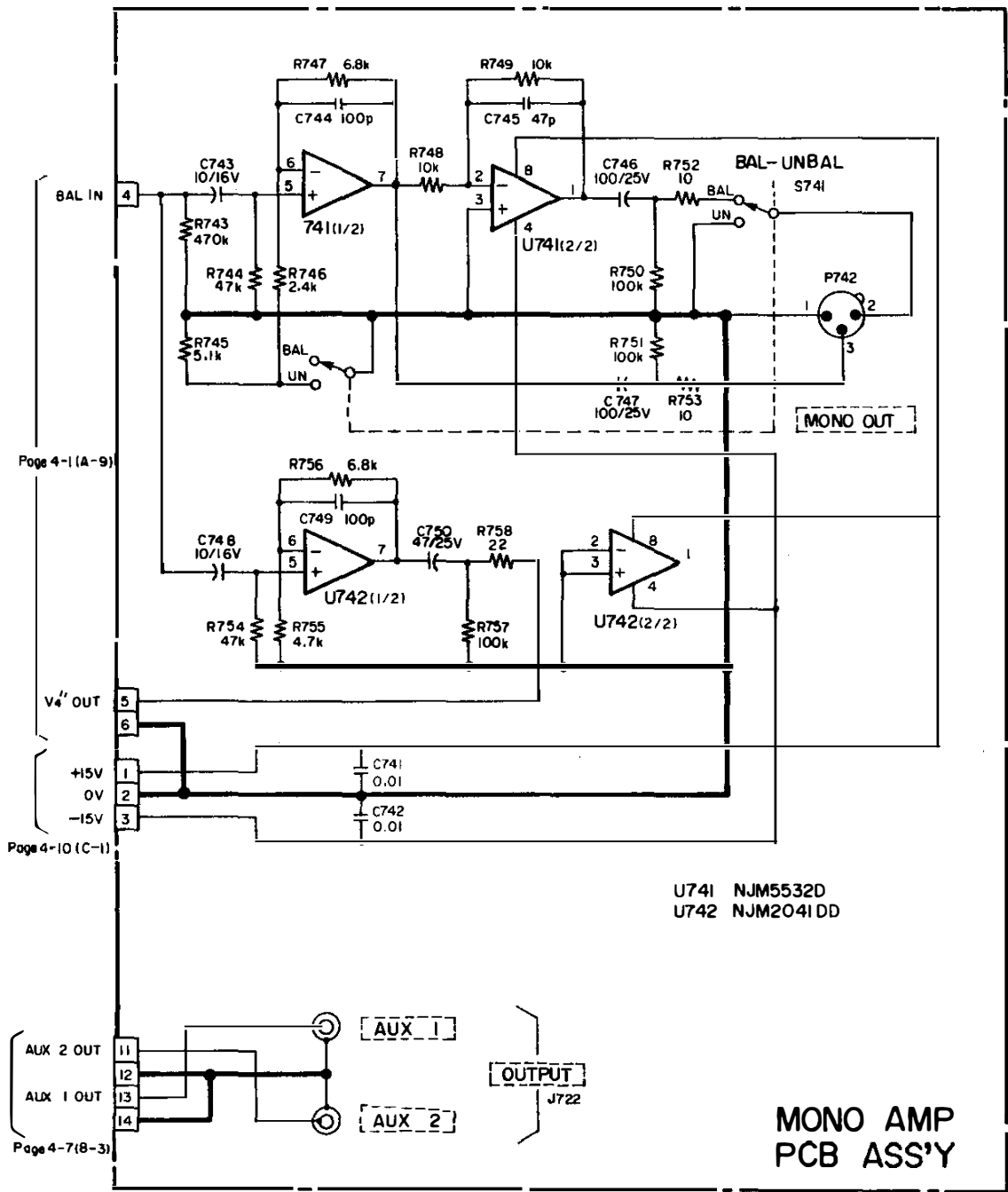

4-12. MONO AMPLIFIER PCB ASS'Y (M-312/M-320)

1 2 3 4

A

B

C

D

E

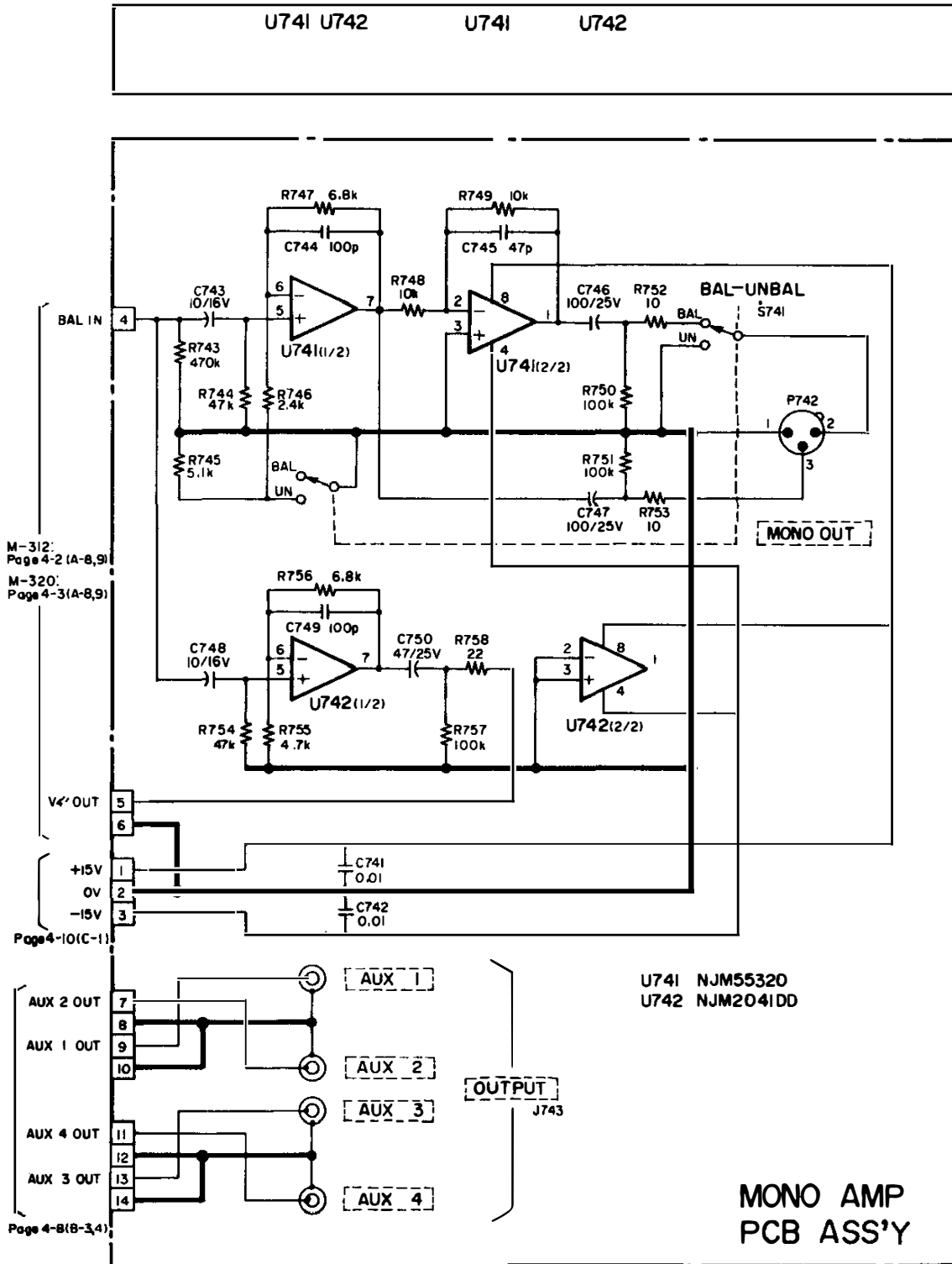

4-13. MONITOR PCB ASS'Y (M-308)

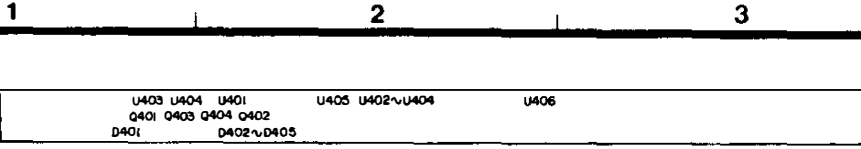

A

B

C

D

E

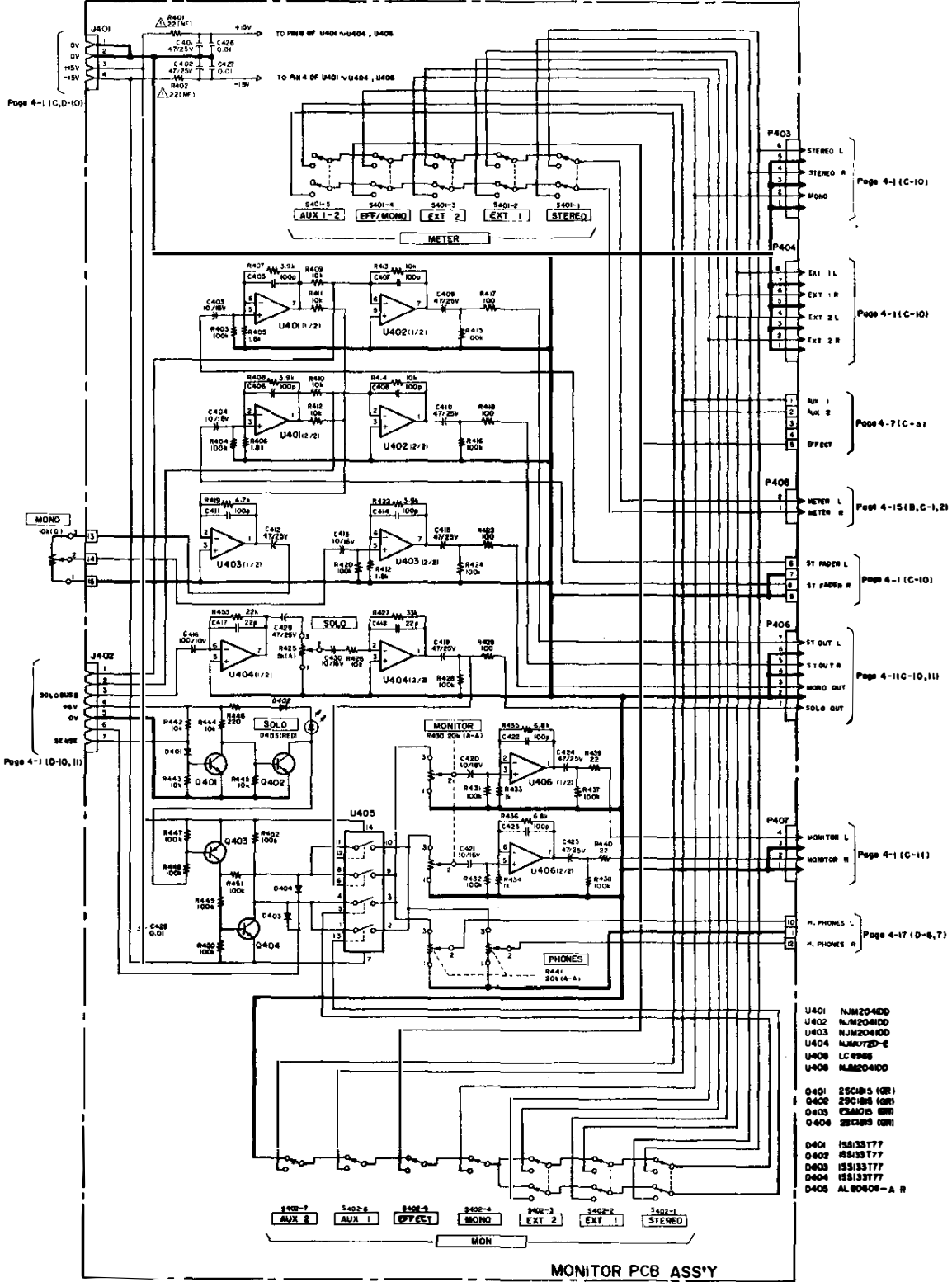

Page 4-1 (C-10)

Page 4-1 (C-10)

Page 4-7 (C-5)

Page 4-15 (B, C-1, 2)

Page 4-1 (C-10)

Page 4-1 (C-10, 11)

Page 4-1 (C-11)

Page 4-17 (D-5, 7)

- U401 NJM204DD
- U402 NJM204DD
- U403 NJM204DD
- U404 NJM204DD-E
- U405 LC 6905
- U406 NJM204DD
- D401 25C185 (GR)
- D402 25C185 (GR)
- D403 25C185 (GR)
- D404 25C185 (GR)
- D401 158133T77
- D402 158133T77
- D403 158133T77
- D404 158133T77
- D405 AL 80609-A R

MONITOR PCB ASS'Y

4-14. MONITOR PCB ASS'Y (M-312/M-320)

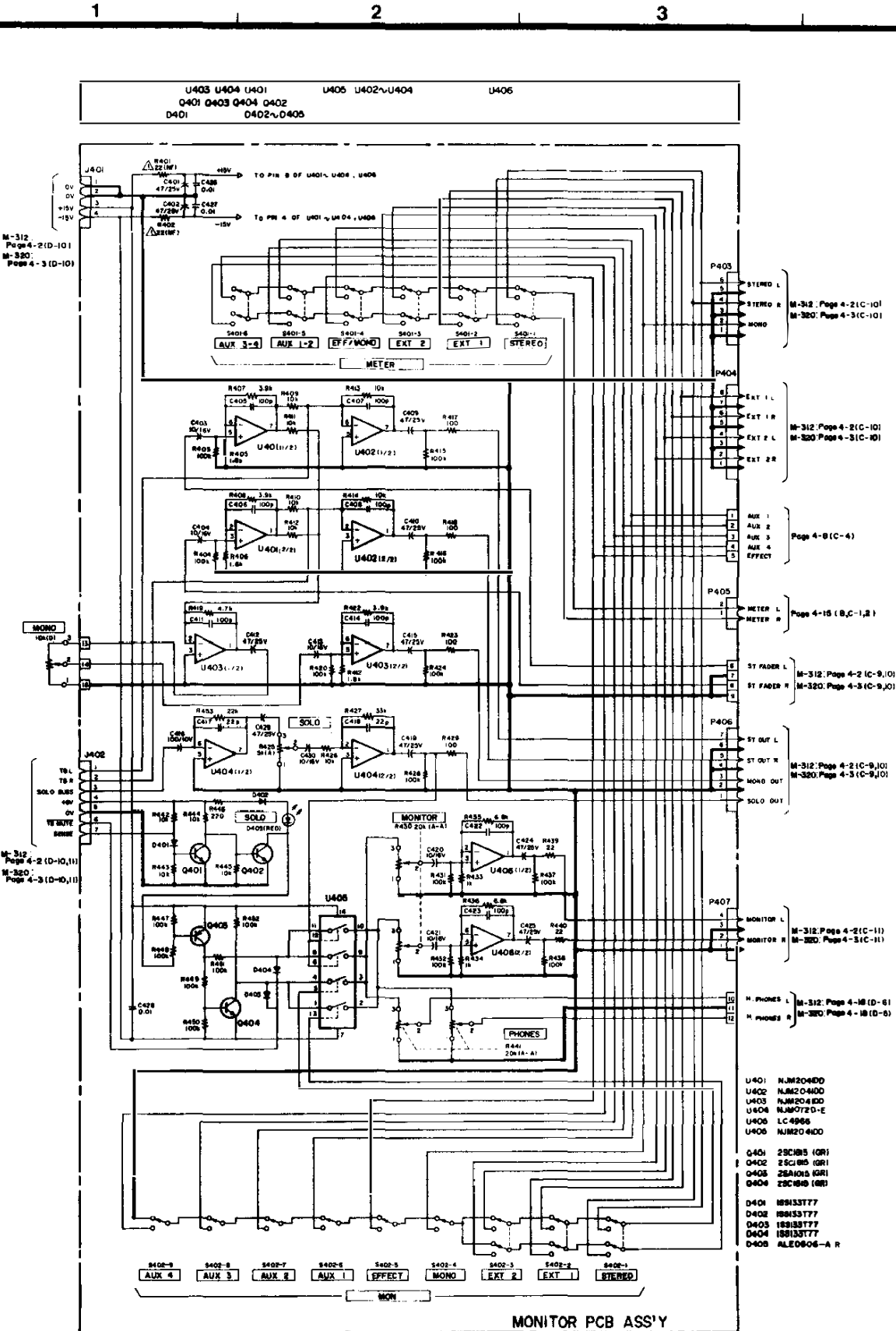

4-15. METER PCB ASS'Y

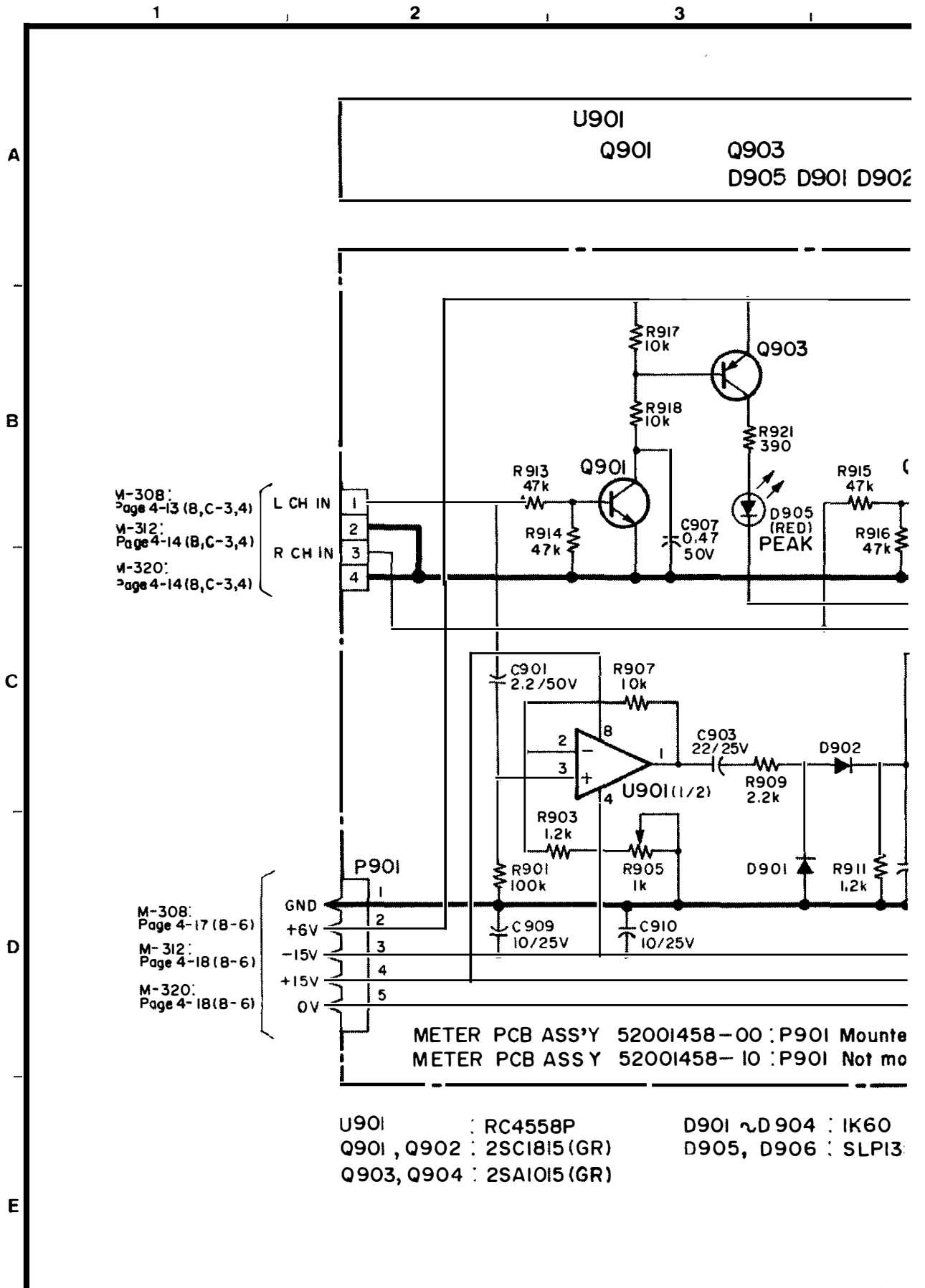

	U901	
Q902	Q904	
	D906	D903 D904

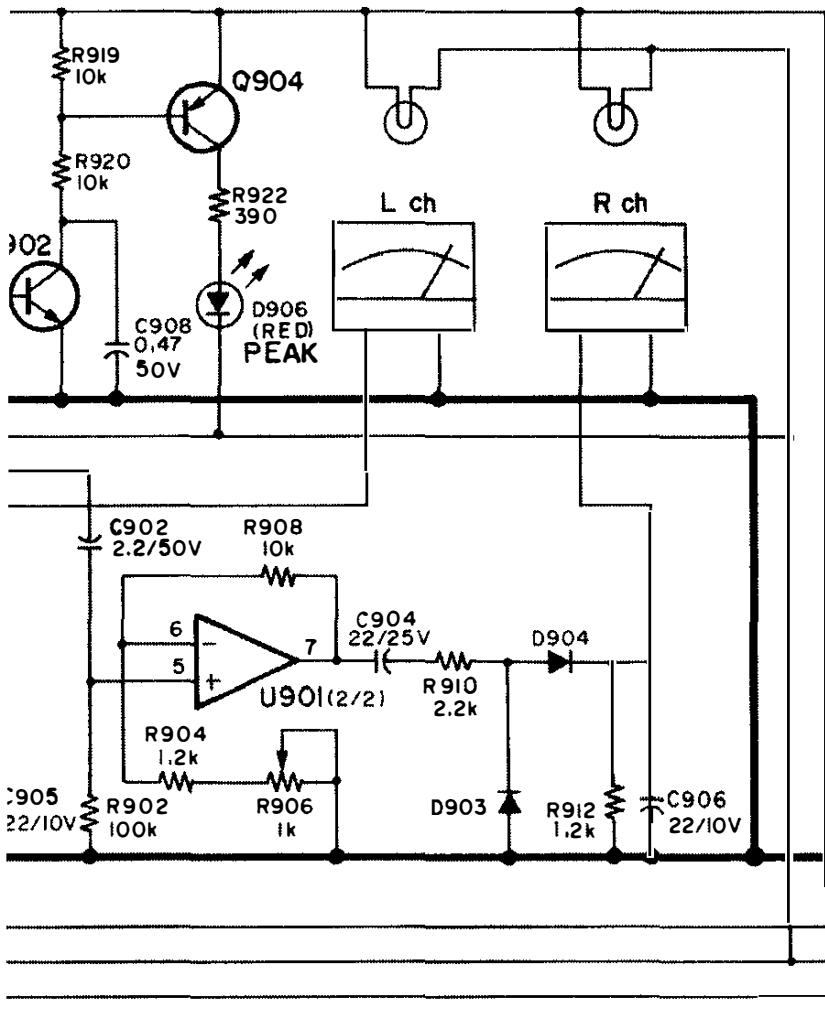

- 5
 - 6
 - 7
 - 8
 - 9
- M-308:
Page 4-1 (A-11)
M-312:
Page 4-2 (A-11)
M-320:
Page 4-3 (A-11)

nted **METER PCB ASS'Y**

4-16. TALKBACK PCB ASS'Y (M-312/M-320)

1

2

3

4

A

B

C

D

E

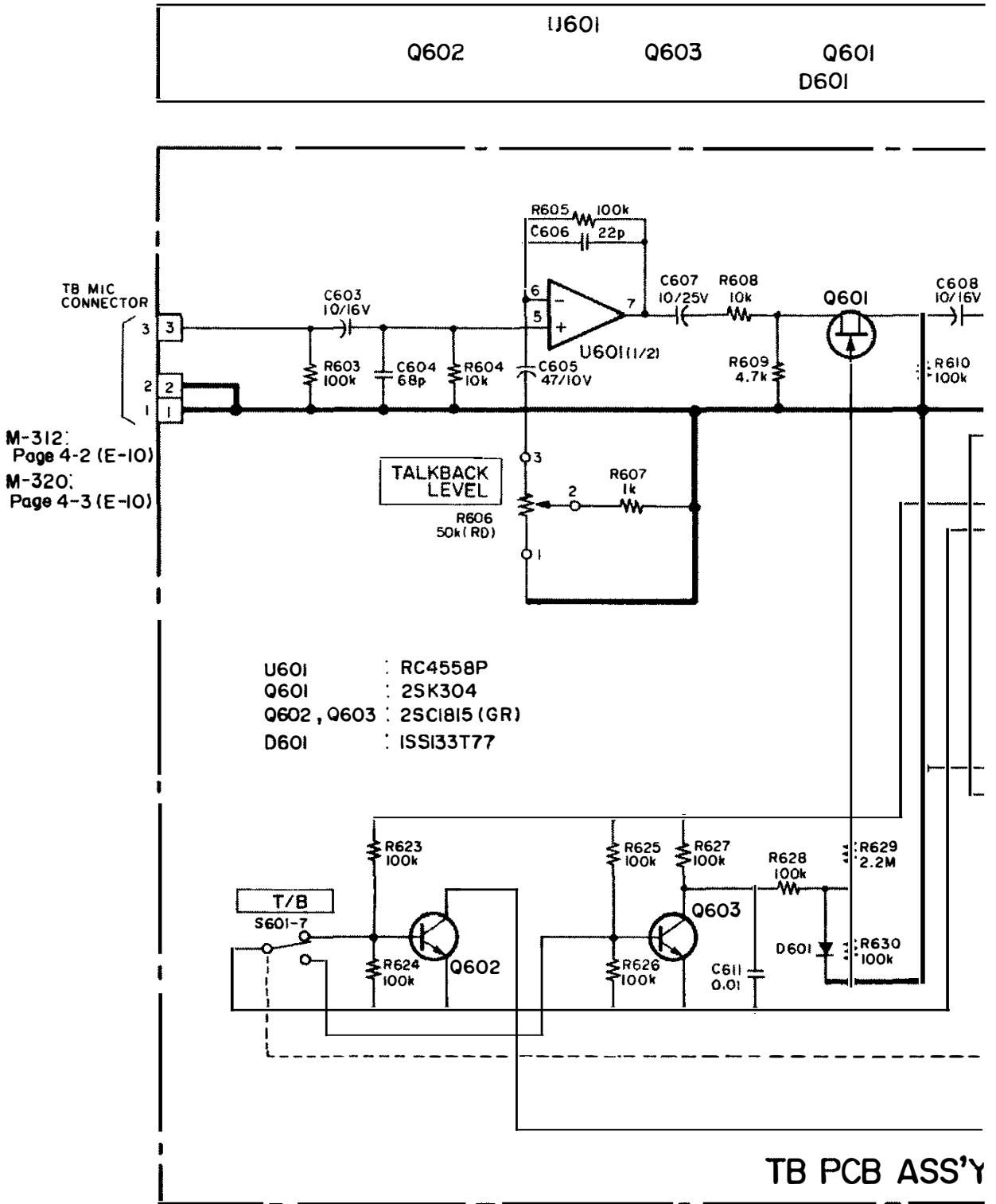

TB PCB ASS'Y

U601

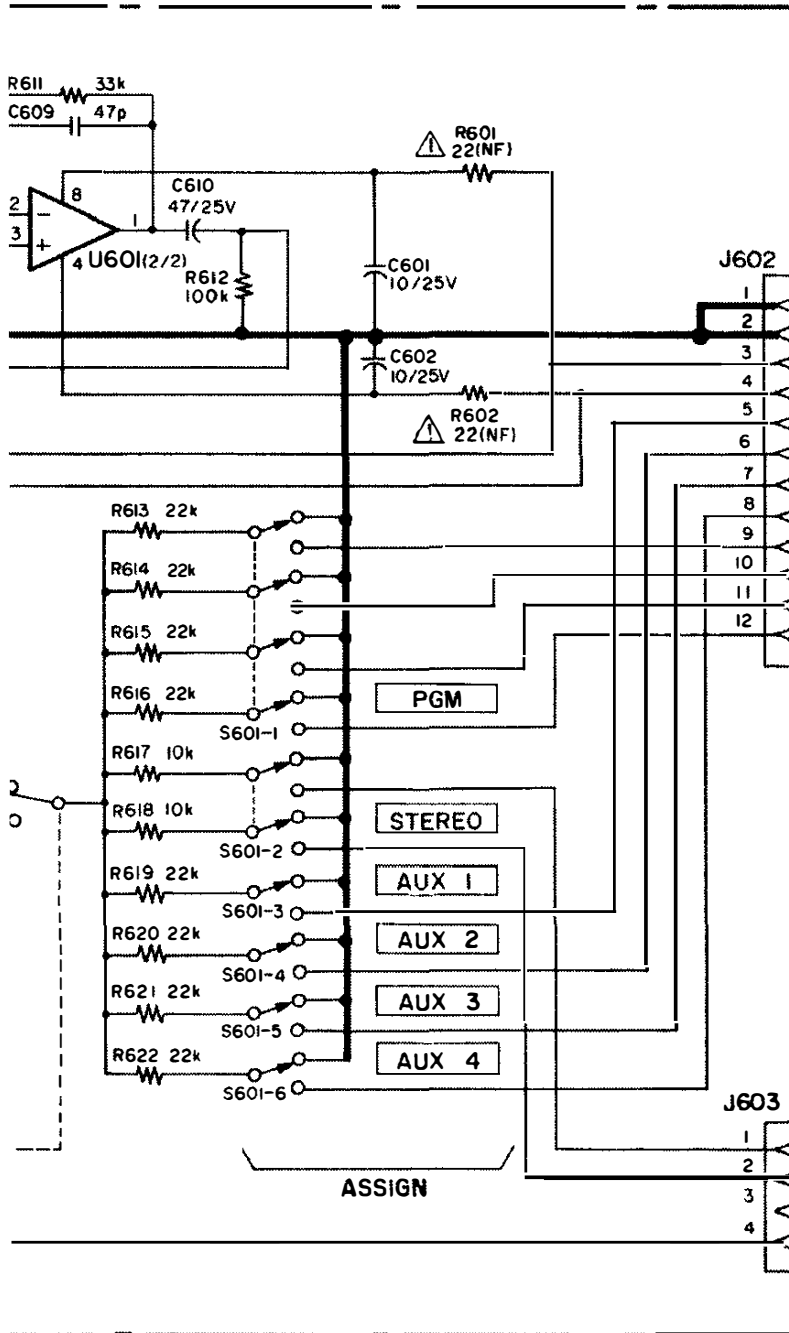

M-312 : Page 4-2 (E-10,11)
 M-320: Page 4-3 (E-10,11)

M-312 : Page 4-2 (E-11)
 M-320: Page 4-3 (E-11)

4.17. POWER SUPPLY SECTION (M-308)

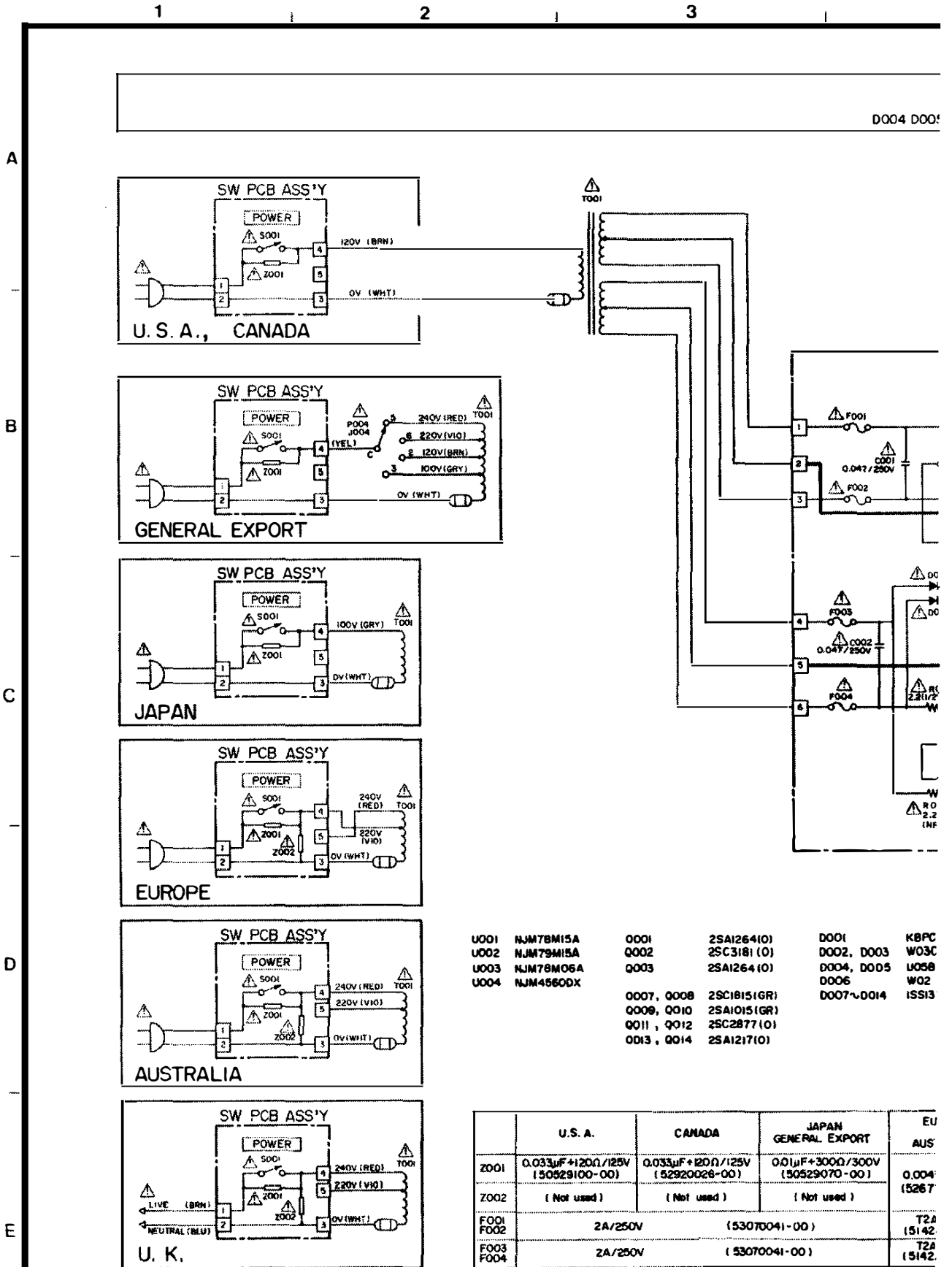

- | | | | | | |
|------|-----------|------------|-------------|------------|-------|
| U001 | NJM78M15A | Q001 | 2SA1264(O) | D001 | K8PC |
| U002 | NJM79M15A | Q002 | 2SC3181(O) | D002, D003 | W03C |
| U003 | NJM78M06A | Q003 | 2SA1264(O) | D004, D005 | U058 |
| U004 | NJM4560DX | Q007, Q008 | 2SC1815(GR) | D006 | W02 |
| | | Q009, Q010 | 2SA1015(GR) | D007~D0014 | ISS13 |
| | | Q011, Q012 | 2SC2877(O) | | |
| | | Q013, Q014 | 2SA1217(O) | | |

	U.S. A.	CANADA	JAPAN GENERAL EXPORT	EU AUS
Z001	0.033µF+120Ω/125V (50529100-00)	0.033µF+120Ω/125V (52920026-00)	0.01µF+300Ω/300V (50529070-00)	0.004 (5267
Z002	(Not used)	(Not used)	(Not used)	
F001 F002	2A/250V	(53070041-00)		T22 (5142
F003 F004	2A/250V	(53070041-00)		T22 (5142.

Q001 D001 D006	U004 Q002 D007~D014	U003 Q007~Q014	U001 U002 Q003 D002 D003
-------------------	---------------------------	-------------------	--------------------------------

TR PCB ASS'Y (A) TR PCB ASS'Y (B) TR PCB ASS'Y (A)

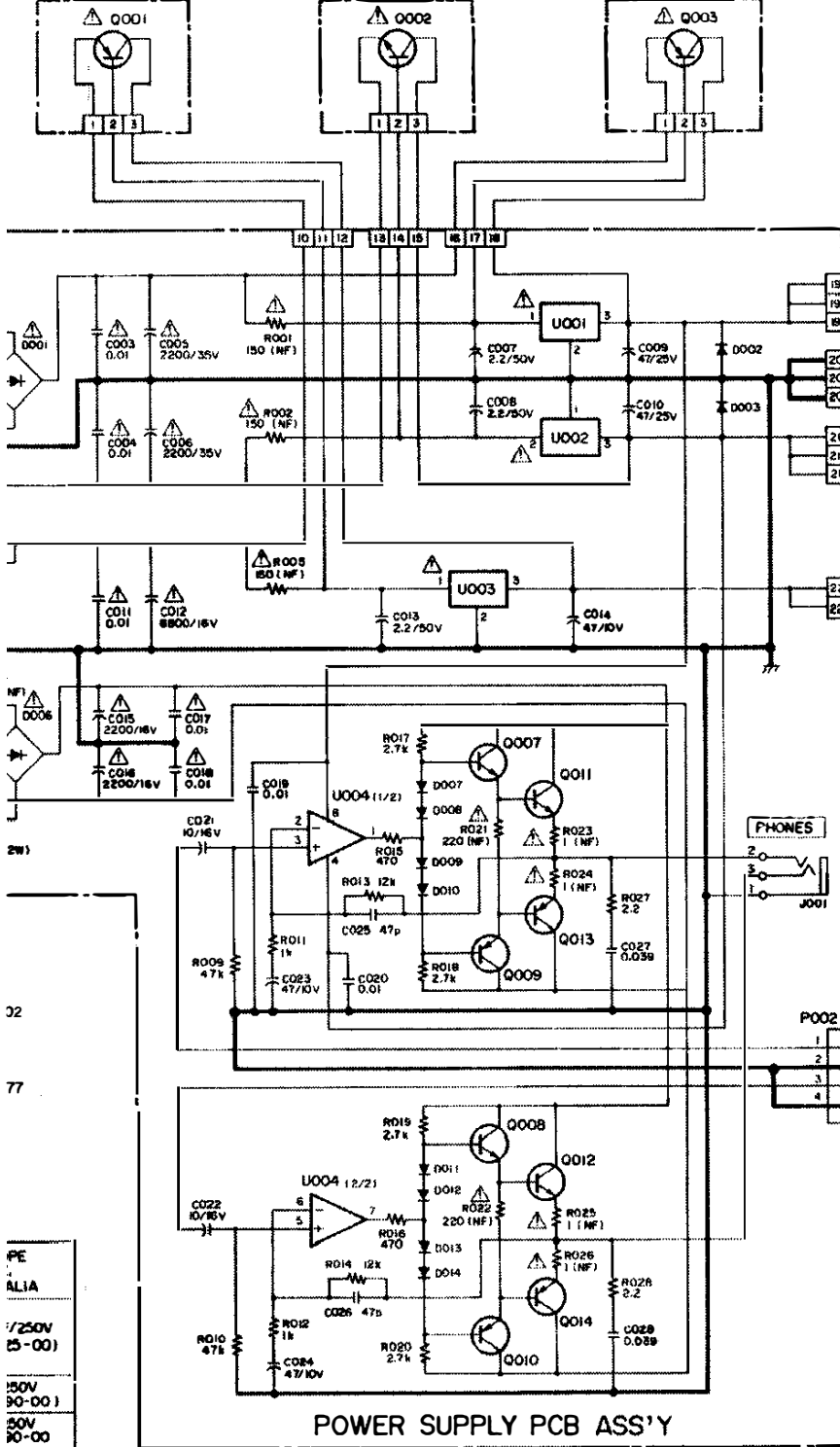

Page 4-15 (D-2)

Page 4-15 (D-3,4)

PE
AL1A
1/250V (5-00)
150V (90-00)
50V (30-00)

4-18. POWER SUPPLY SECTION (M-312/M-320)

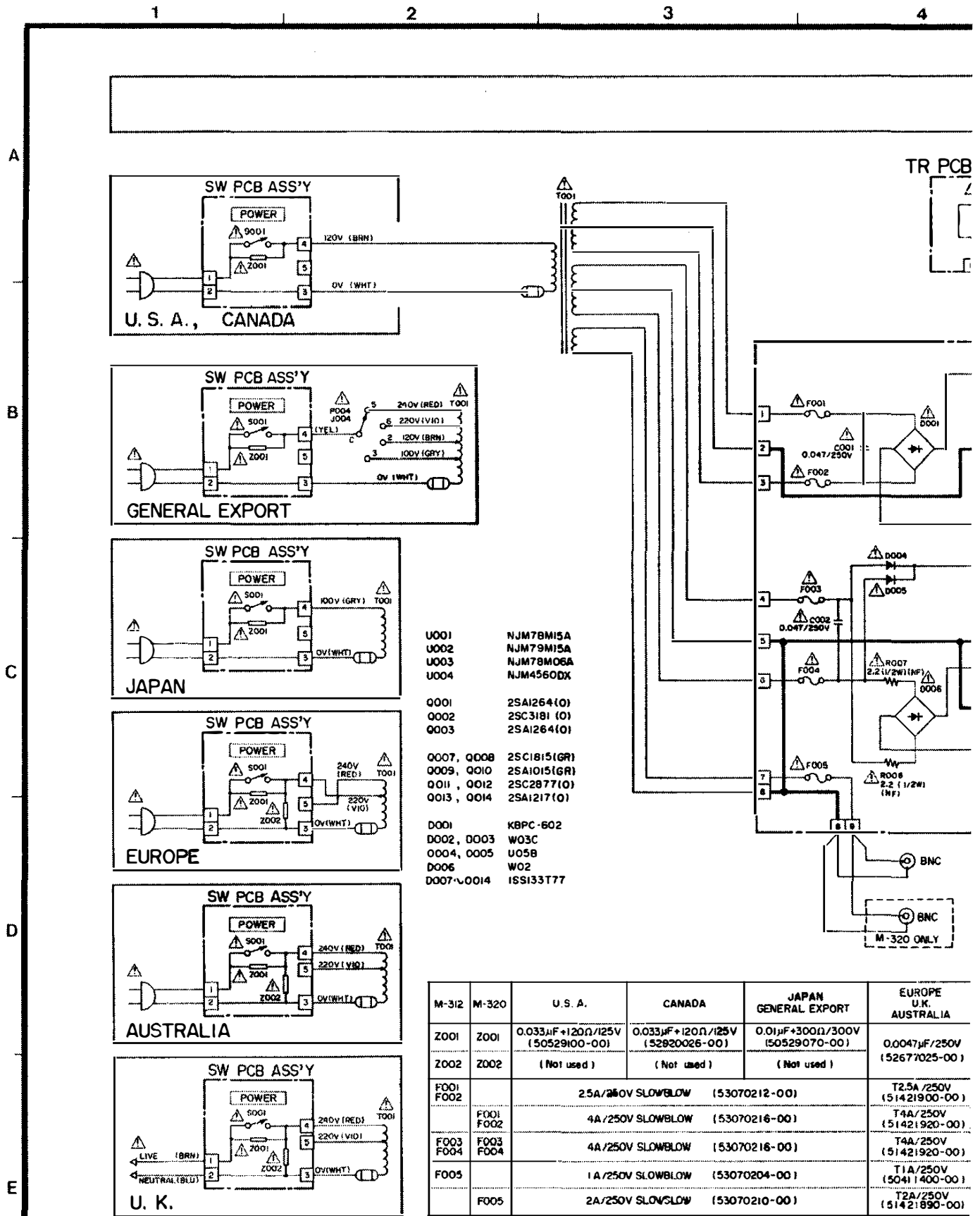

	U004	U003	U001	U002
Q001	Q002	Q007~Q014	Q003	
	D007~D014		D002	D003

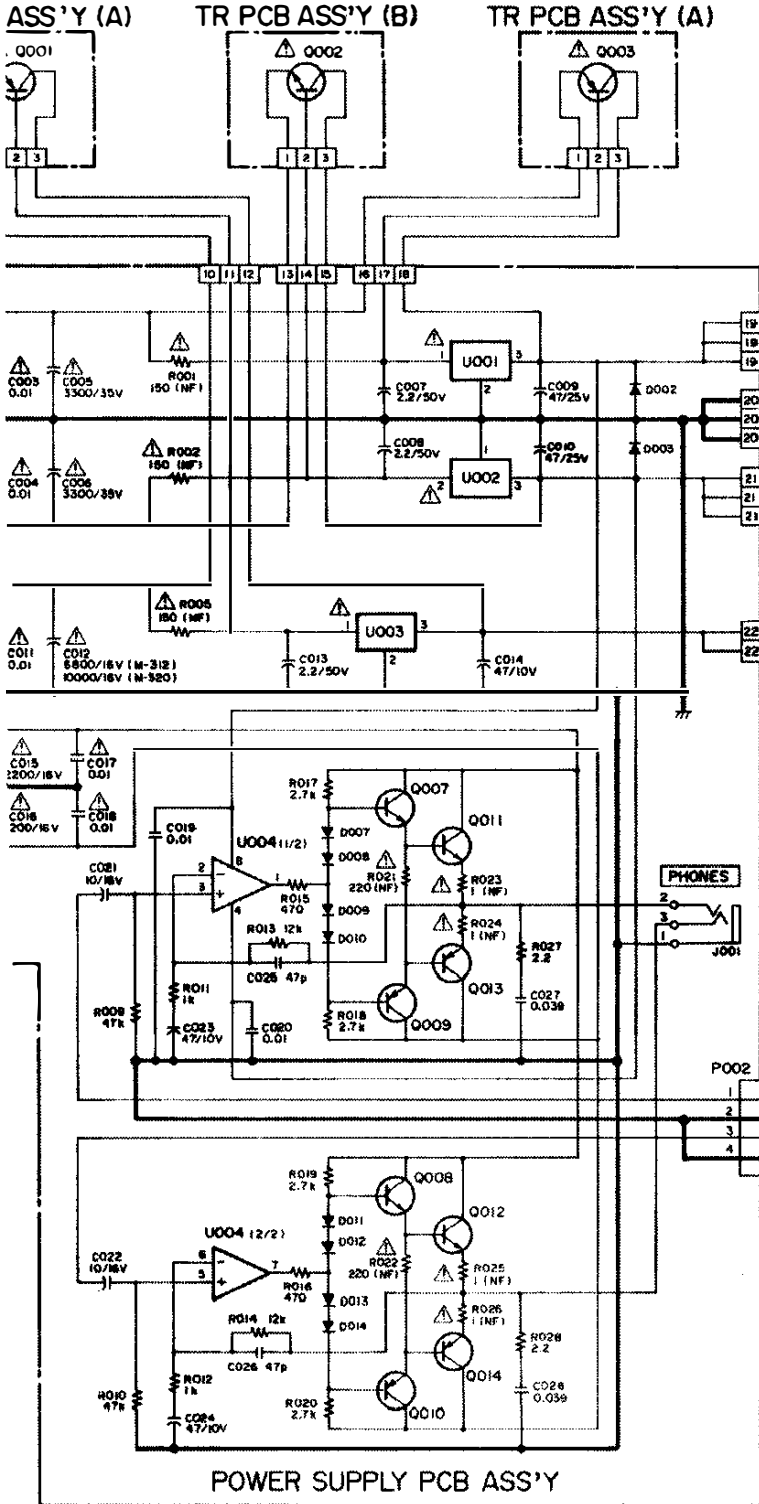

Page 4-15 (D-2)

M-312: Page 4-14 (D-3,4)
M-320: Page 4-14 (D-3,4)

4-19. RIAA PCB (M-308) (JAPAN MODEL ONLY)

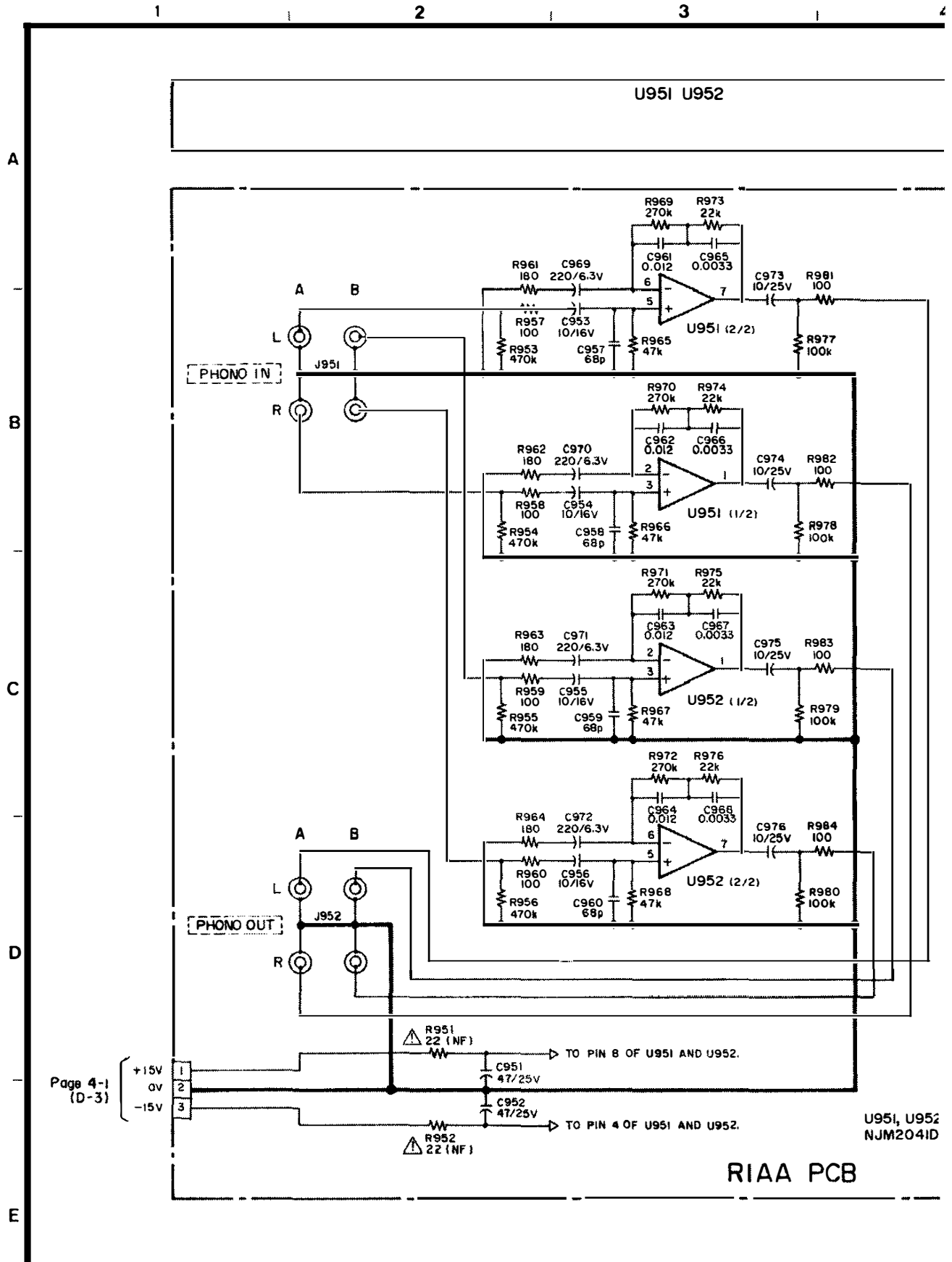

Page 4-1
(D-3)

U951, U952
NJM2041D

RIAA PCB

4-20. IC Internal Block Diagrams

NJM4558
 NJM5532D
 NJM2041DD
 NJM4560DX
 NJM072DE

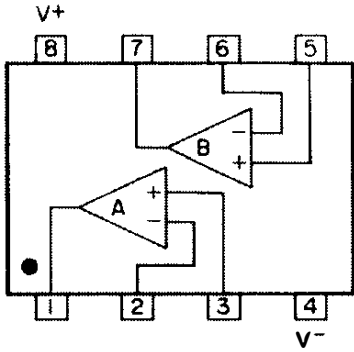

NJM78M06A
 NJM78M15A
 NJM79M00



Pin No.	78M06A 78M15A	79M00
1	OUT	OUT
2	GND	IN
3	IN	GND

LC4966

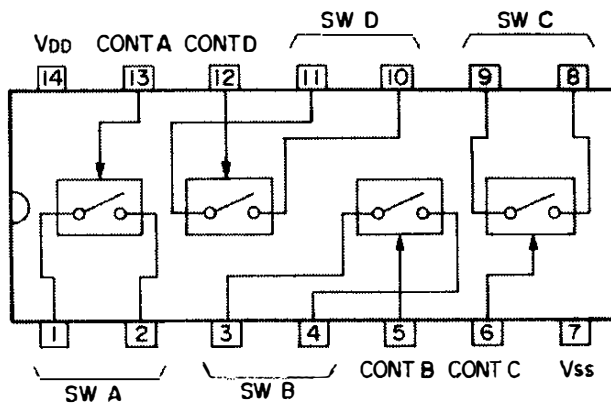

4-20. BLOCK DIAGRAM (M-308)

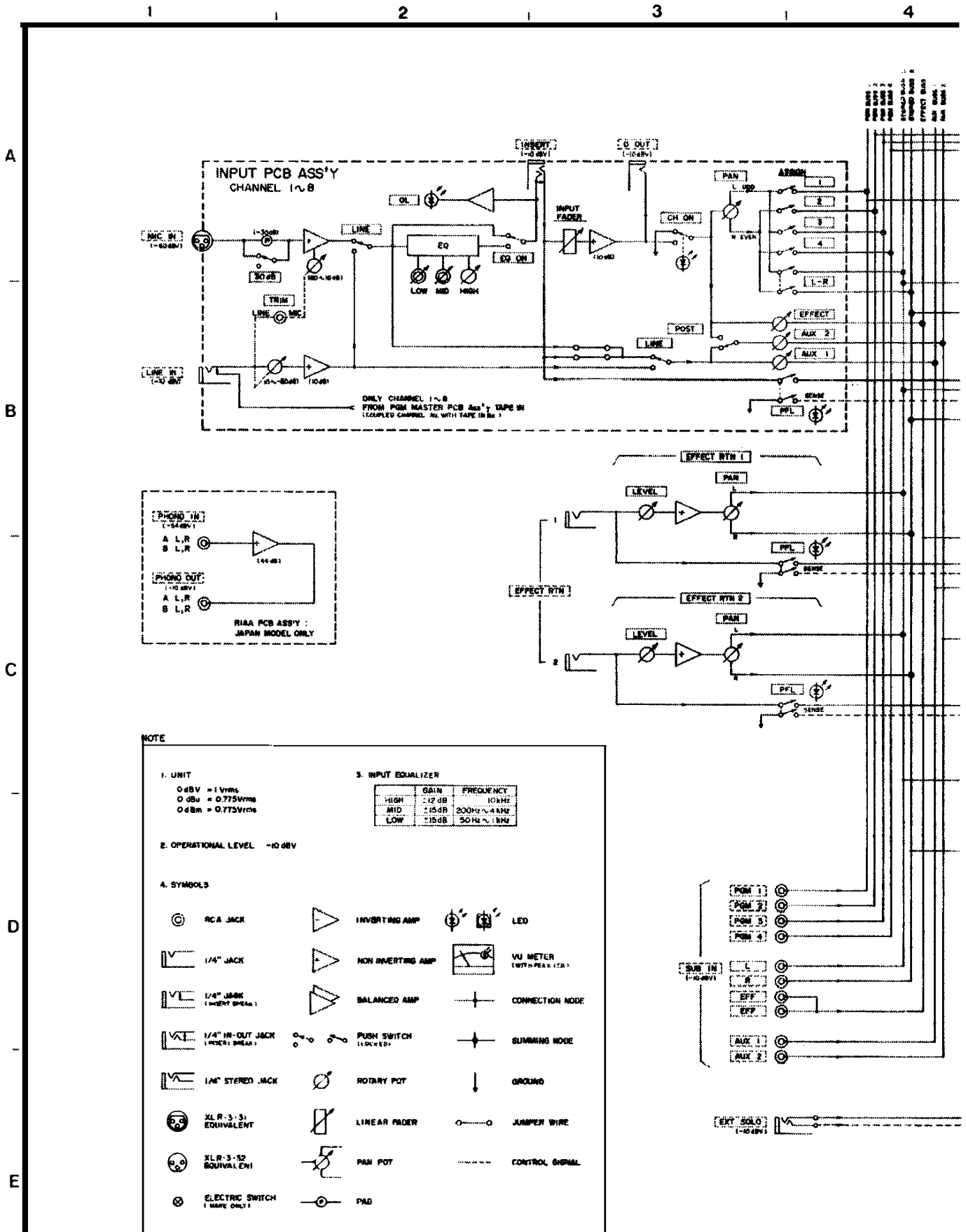

4-21. BLOCK DIAGRAM (M-312/M-320)

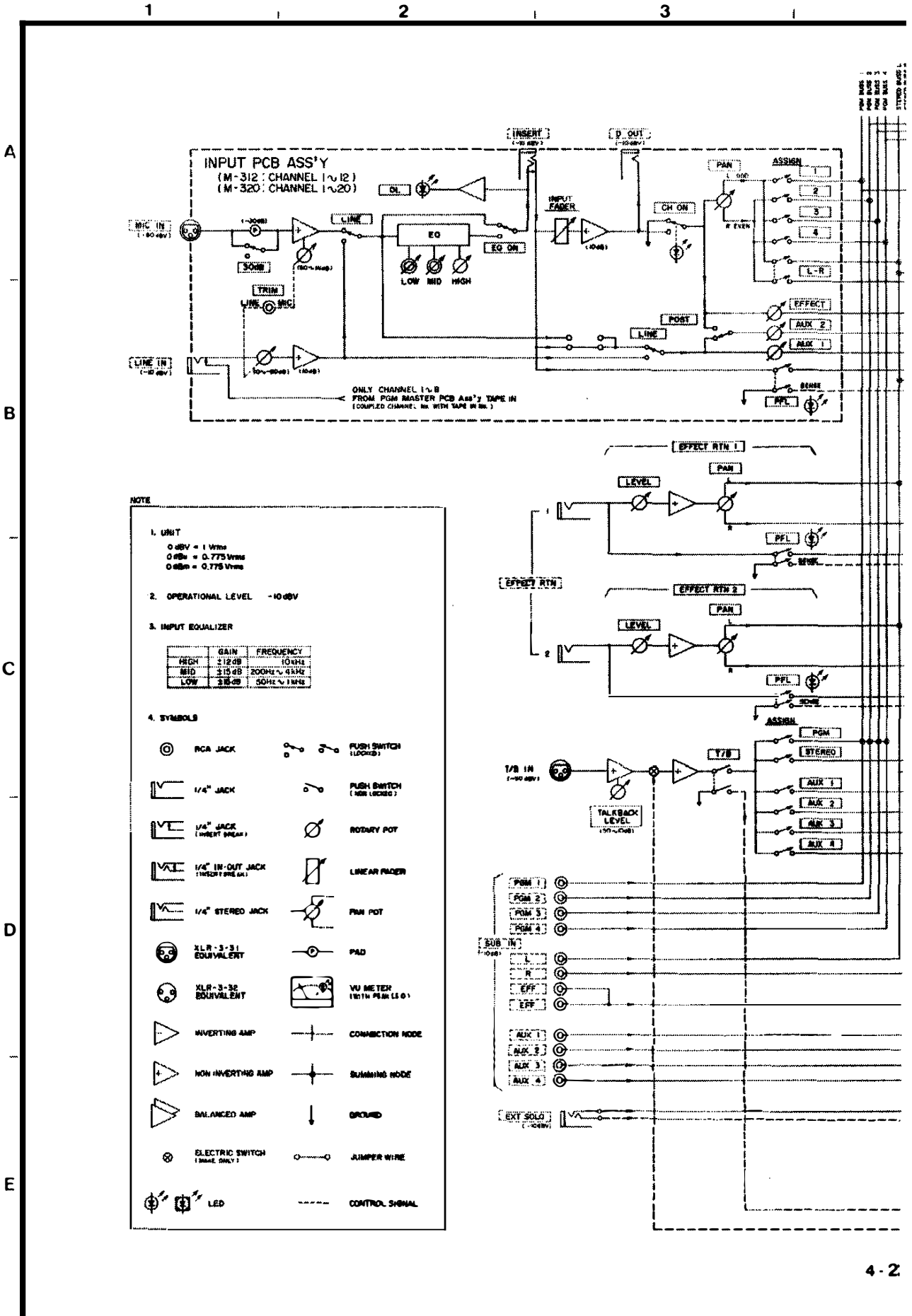

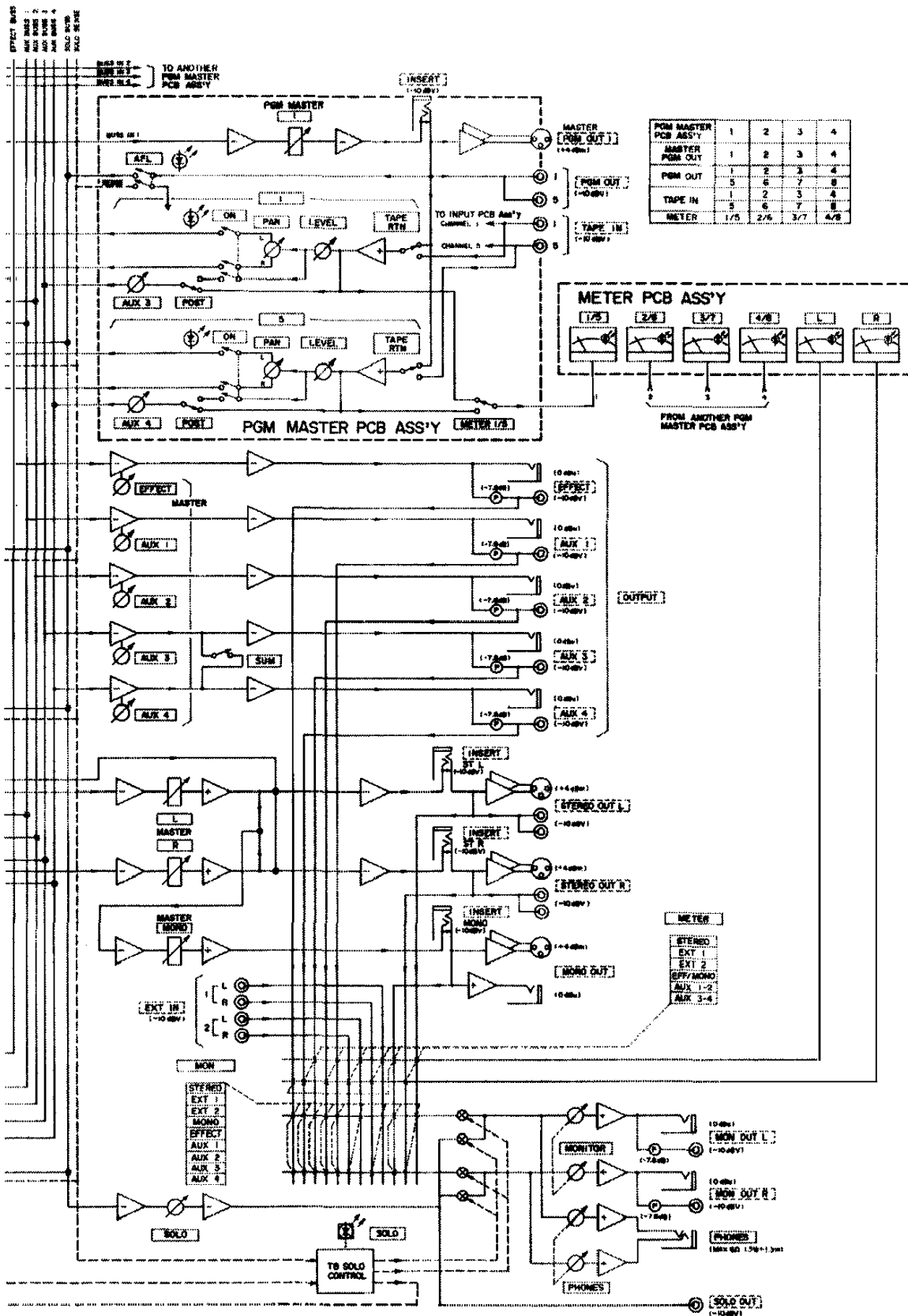

PGM MASTER PCB ASS'Y	1	2	3	4
MASTER PGM OUT	1	2	3	4
PGM OUT	1	2	3	4
TAPE IN	5	6	7	8
TAPE IN	1	2	3	4
METER	1/5	2/5	3/7	4/8

METER	1/5	2/5	3/7	4/8
STEREO	EXT 1	EXT 2	MONO	EFFECT
AUX 1	AUX 2	AUX 3	AUX 4	

MONITOR	10dBu
MON OUT L	(-10dBV)
MON OUT R	(-10dBV)
PHONES	(MAX 8Ω (30+1) 3mA)
SOLO OUT	(-10dBV)

4-22. LEVEL DIAGRAMS (M-308)

1

2

3

4

A

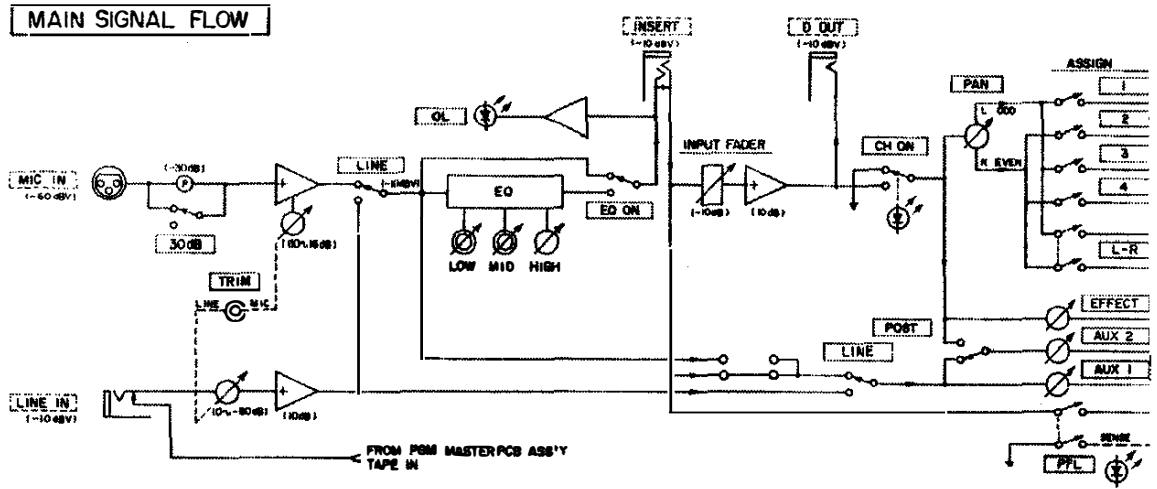

B

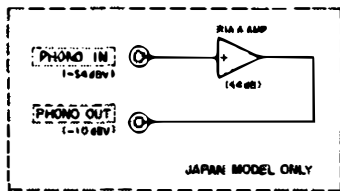

C

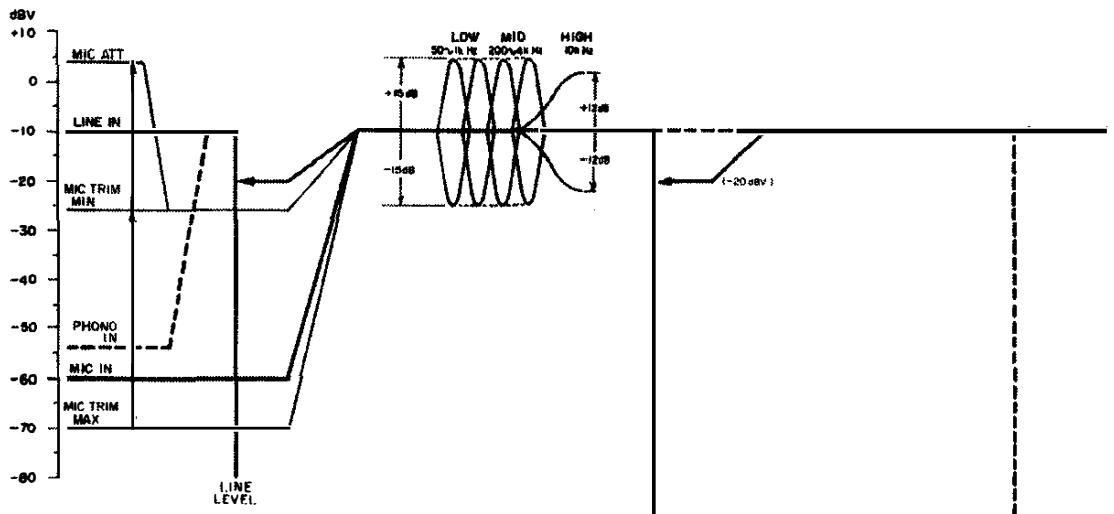

NOTE
 OPERATIONAL LEVEL -10dBV
 0dBV = 1 Vrms
 0dBu = 0.775 Vrms
 0dBm = 0.775 Vrms

D

E

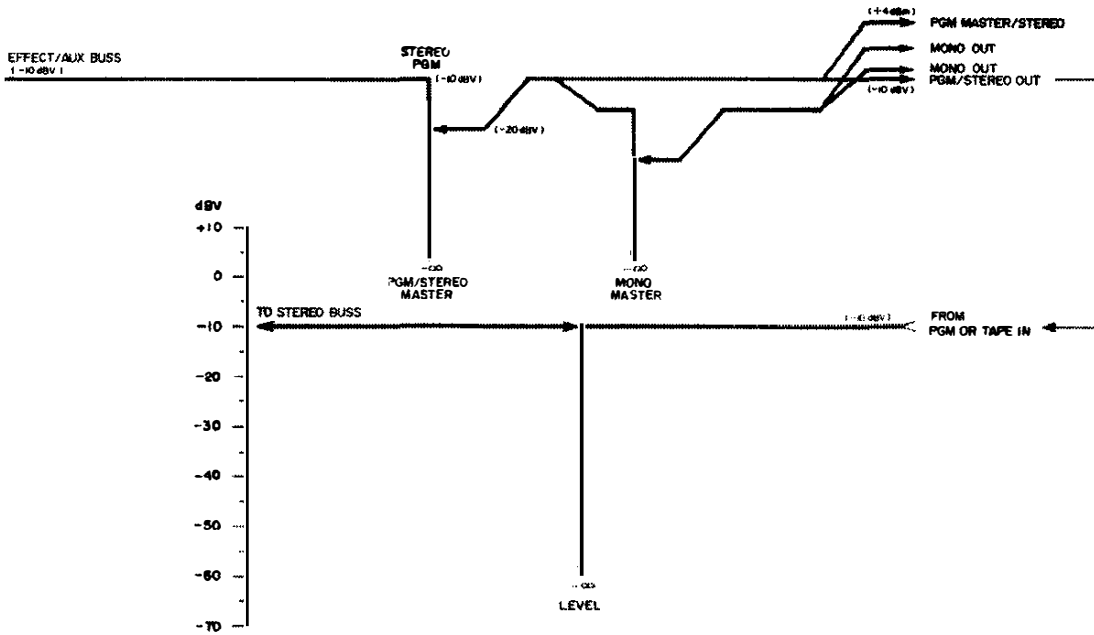
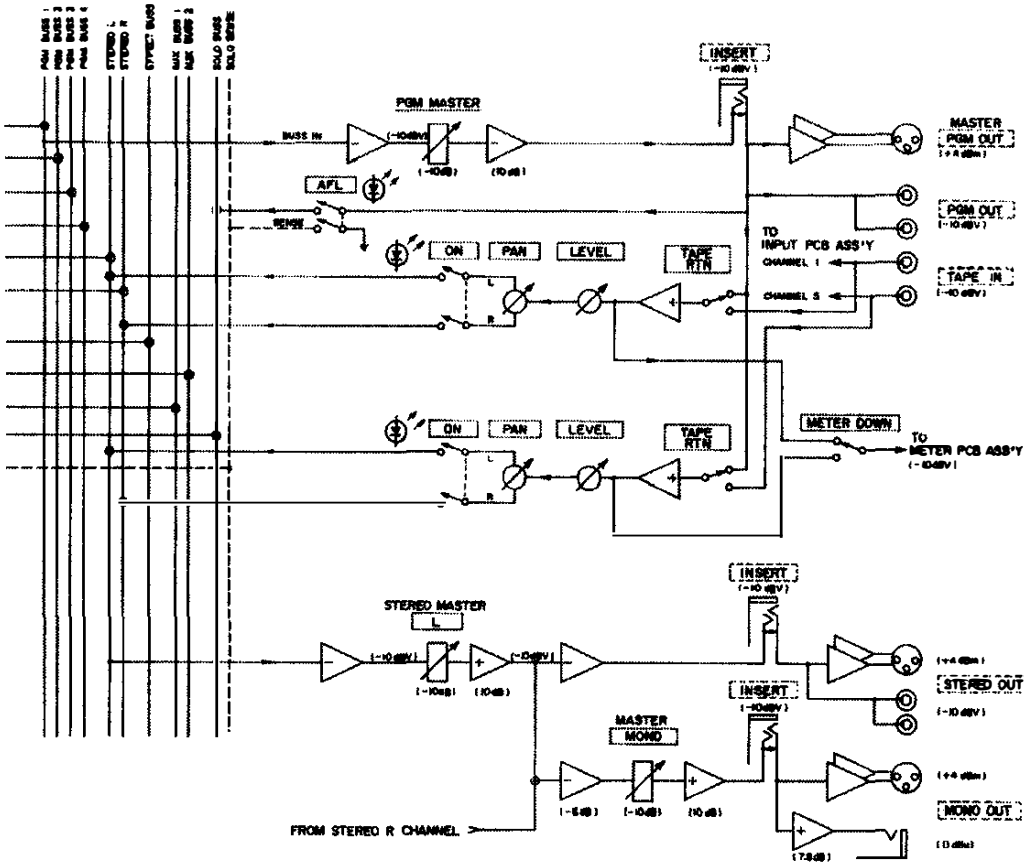

1

2

3

A

B

C

D

E

EFFECT RTN / MONITOR SIGNAL FLOW

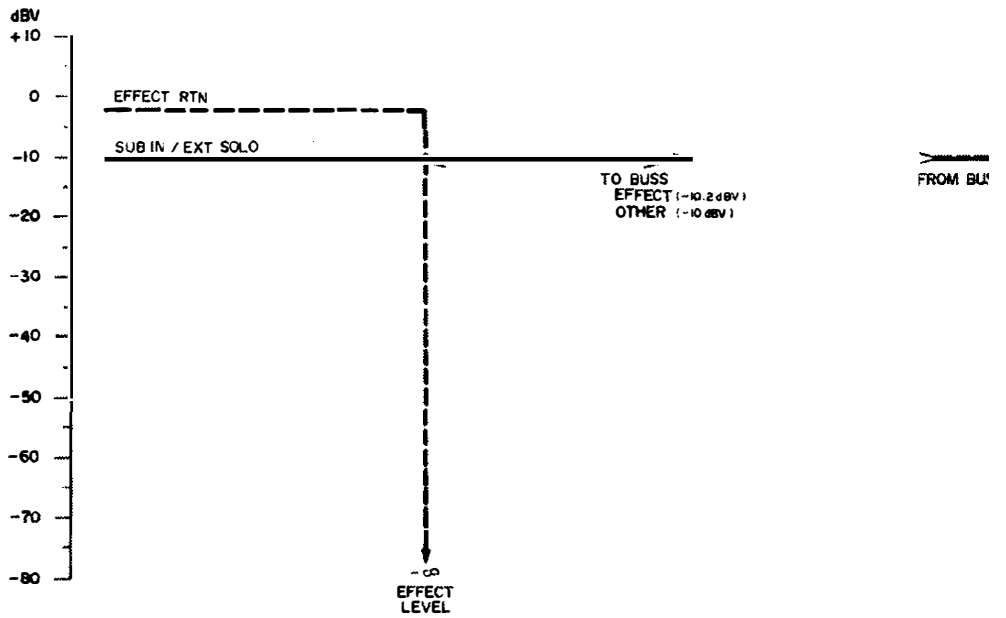
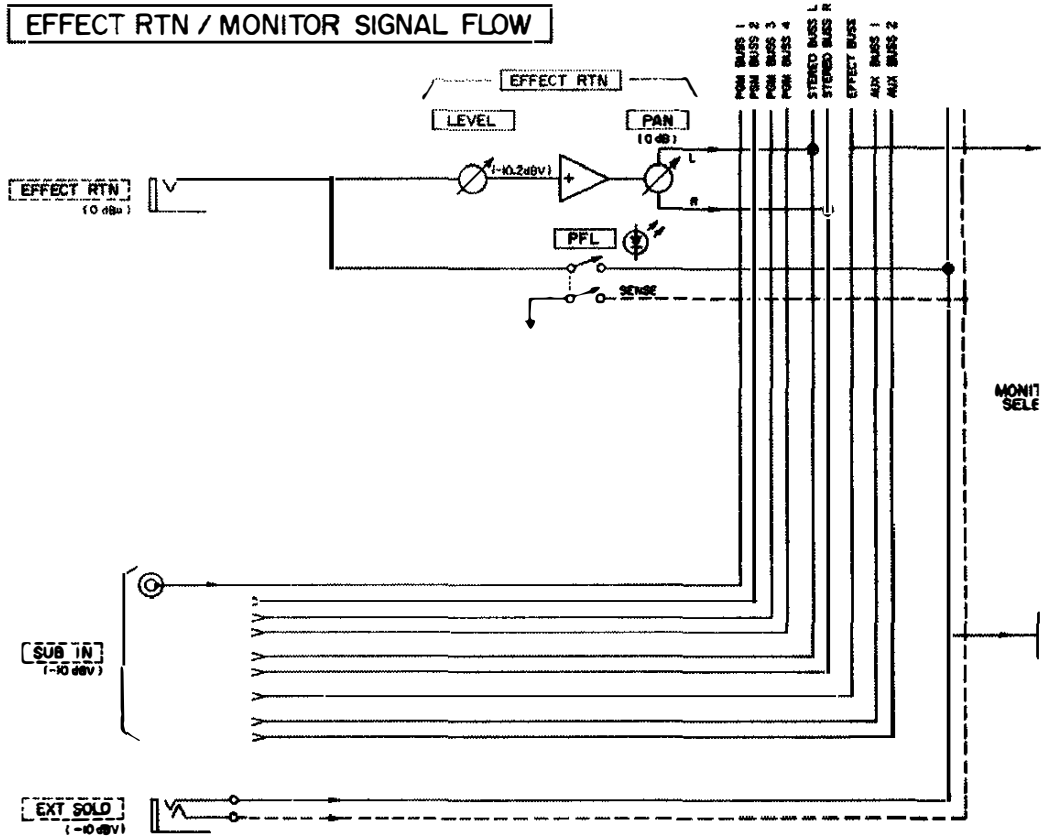

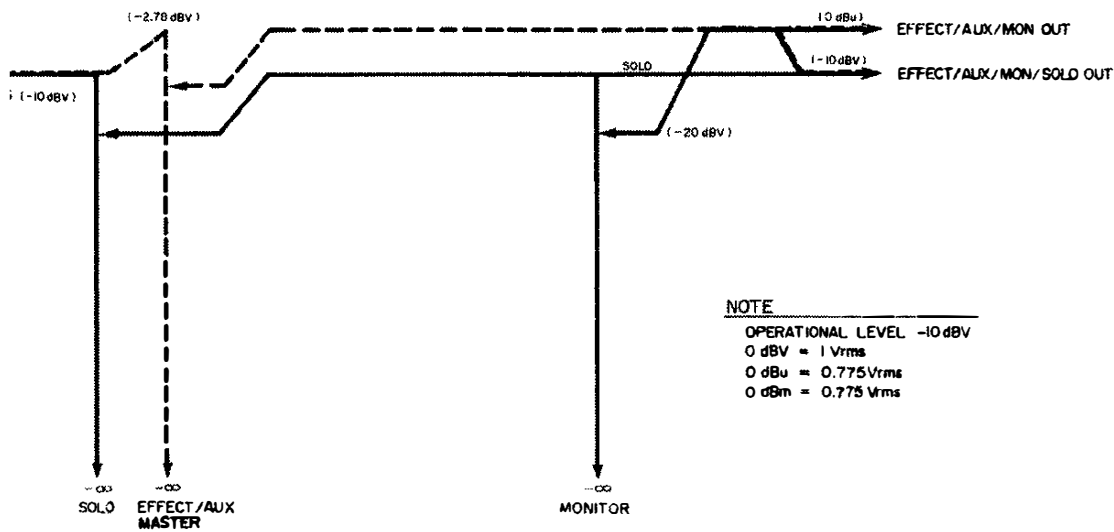
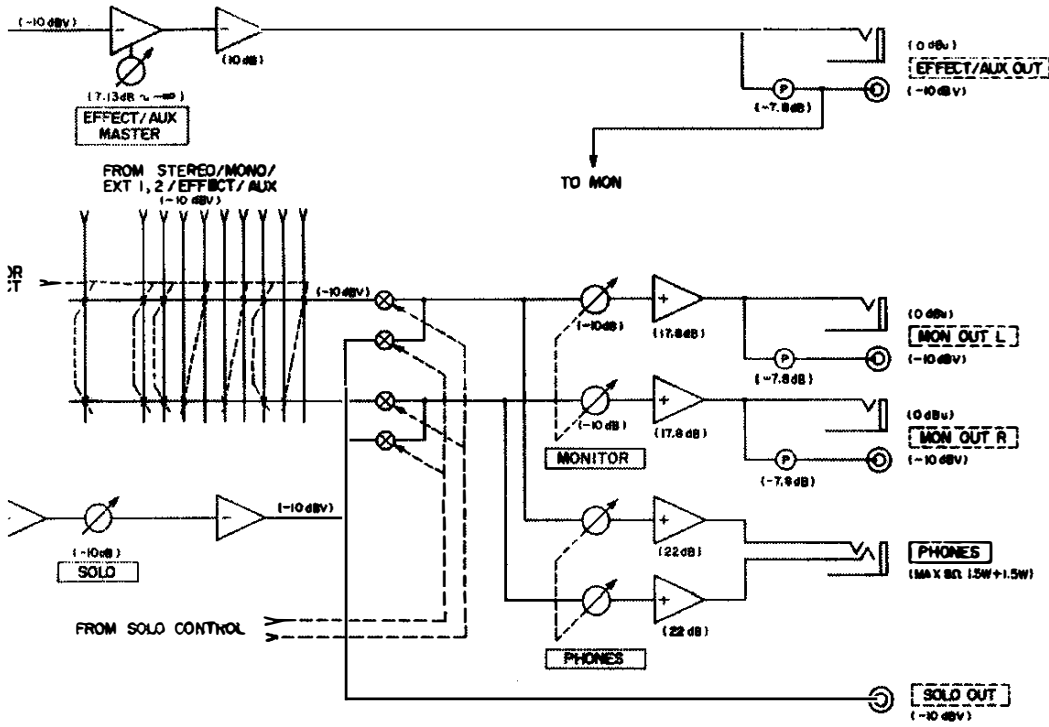

NOTE
 OPERATIONAL LEVEL -10 dBV
 $0\text{ dBV} = 1\text{ Vrms}$
 $0\text{ dBu} = 0.775\text{ Vrms}$
 $0\text{ dBm} = 0.775\text{ Vrms}$

4-23. LEVEL DIAGRAMS (M-312/M-320)

1 | 2 | 3 | 4

A
B
C
D
E

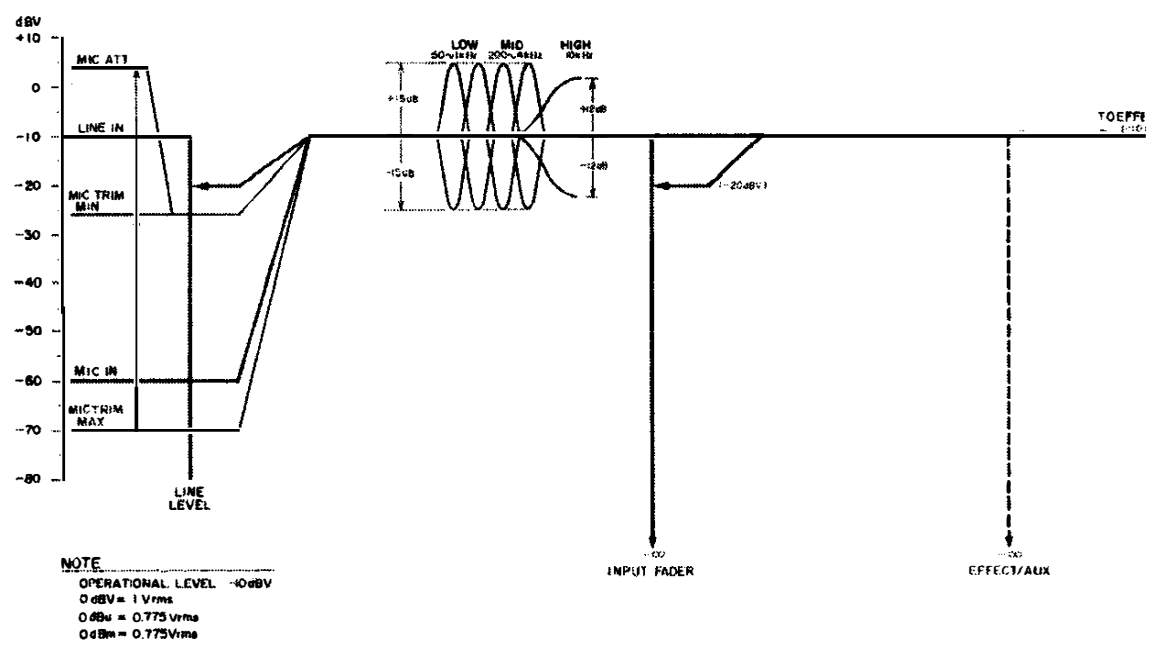
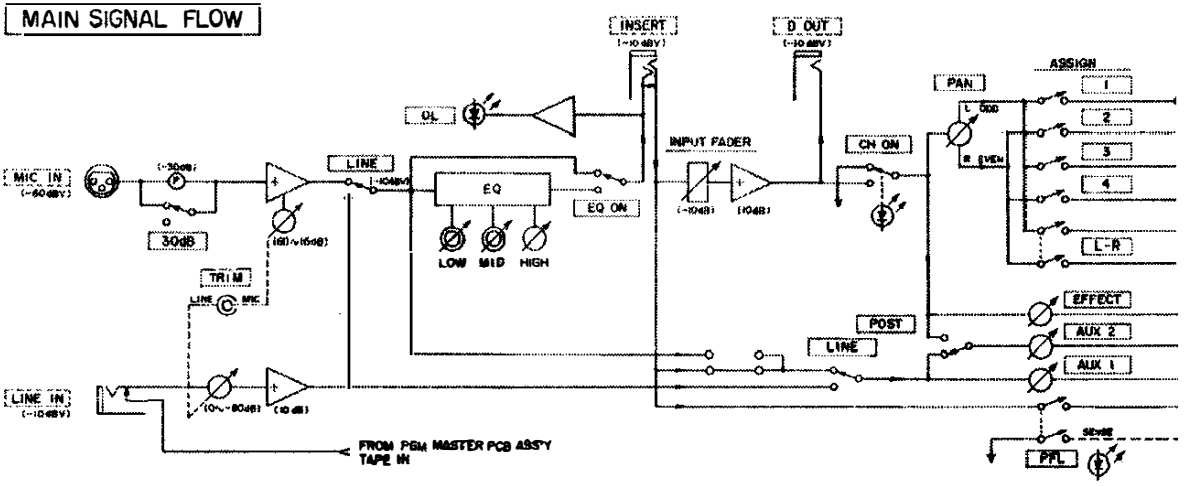

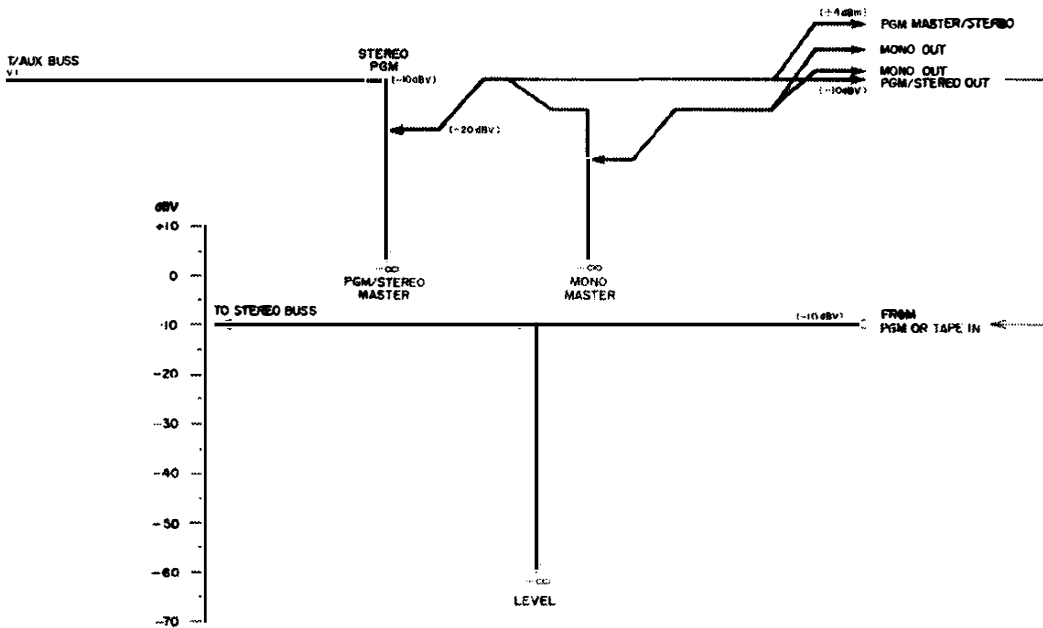
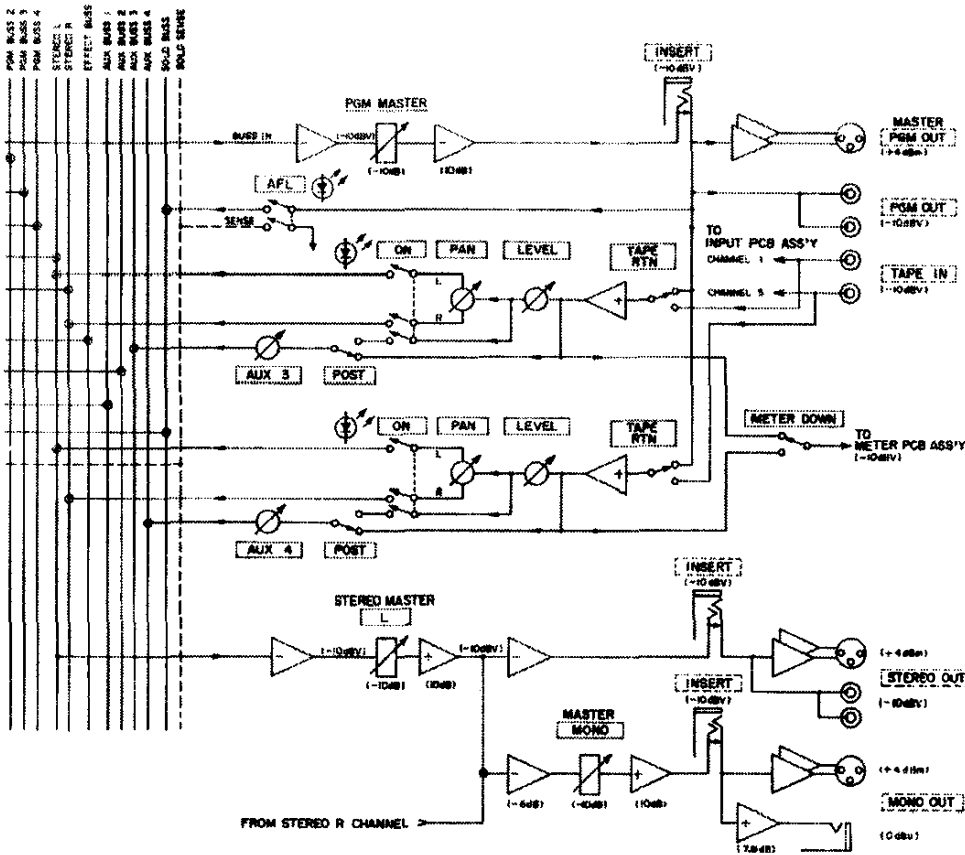

EFFECT RTN / MONITOR SIGNAL FLOW

A
B
C
D
E

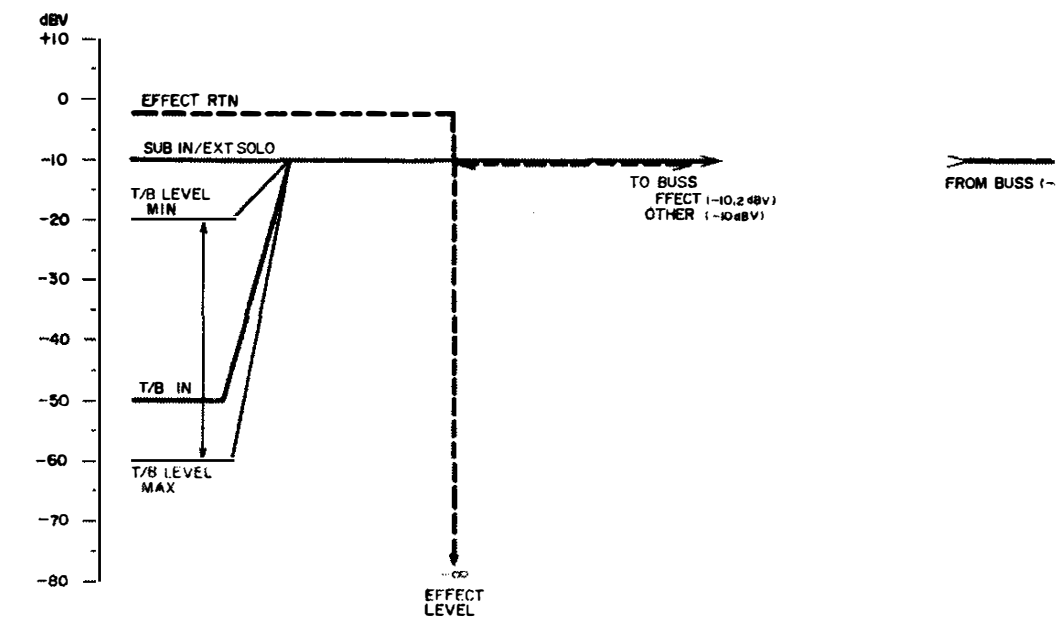
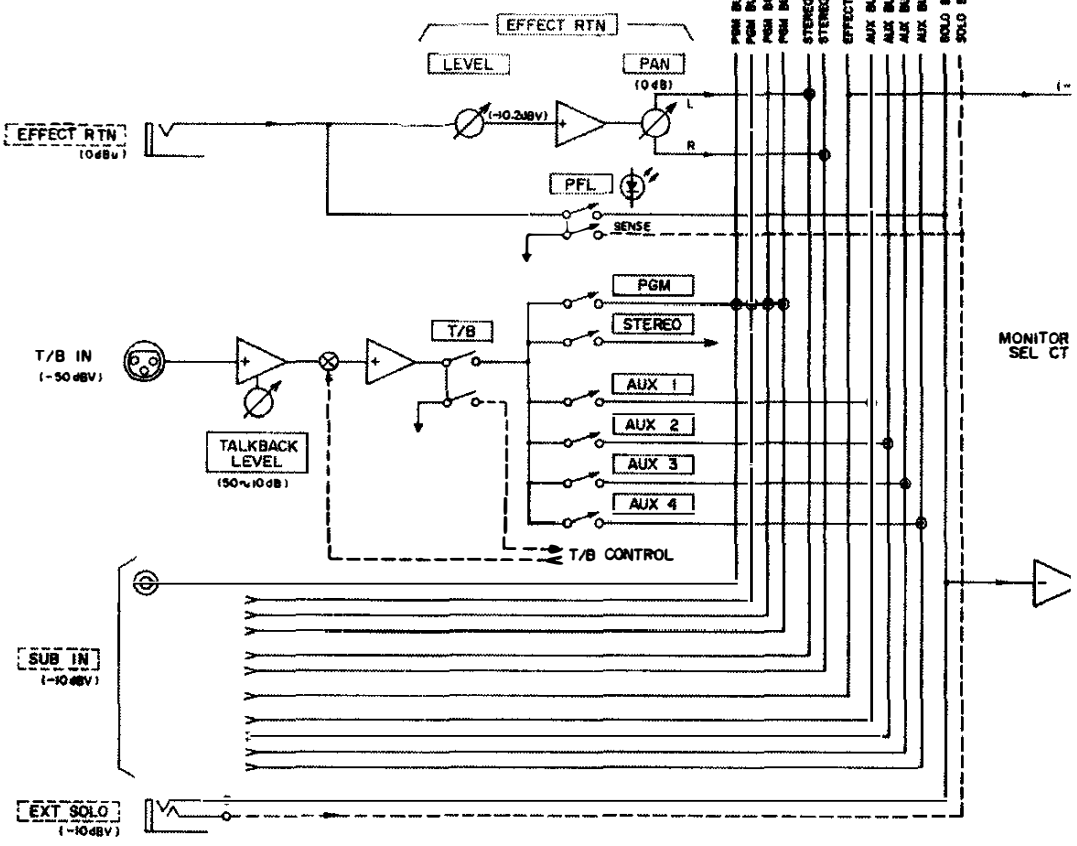

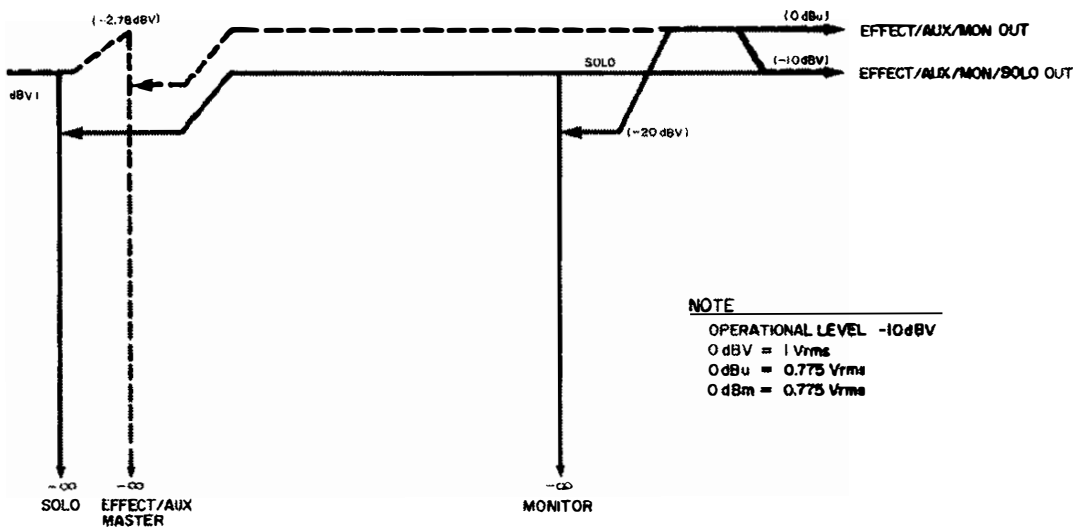
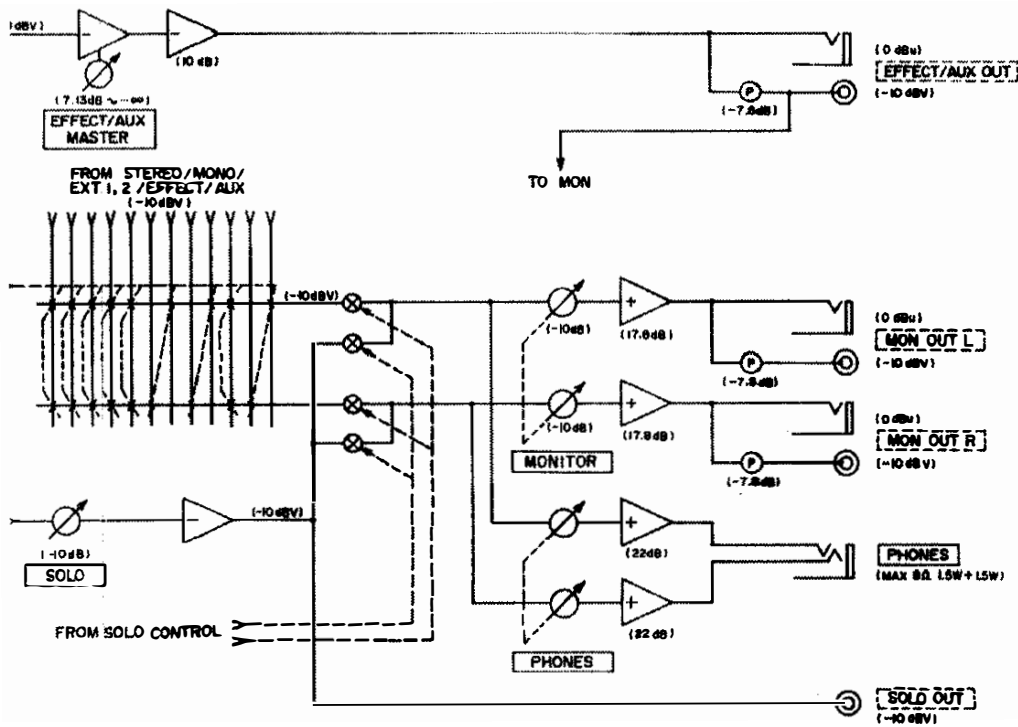

TASCAM

TEAC Professional Division

M-300Series

TEAC CORPORATION

MAIN OFFICE: 3-7-3 NAKACHO MUSASHINO TOKYO PHONE (0422) 53-1111
SALES OFFICE: 4-15-30 SHIMORENJAKU MITAKA TOKYO PHONE (0422) 45-7741

TEAC CORPORATION OF AMERICA

7733 TELEGRAPH ROAD MONTEBELLO CALIFORNIA 90640 PHONE (213) 726-0303

TEAC CANADA LTD.

3610 NASHUA DRIVE UNIT 1 & 2 MISSISSAUGA ONTARIO L4V 1L2 PHONE 416-673-3303

TEAC AUSTRALIA PTY., LTD.

115 WHITEMAN STREET SOUTH MELBOURNE VICTORIA 3205 PHONE 699-6000

PRINTED IN JAPAN 0285U1-D-4739B