

5. CIRCUIT DIAGRAM

5-1 Connector Board and Related Circuitry



5-2 Power Supply Unit

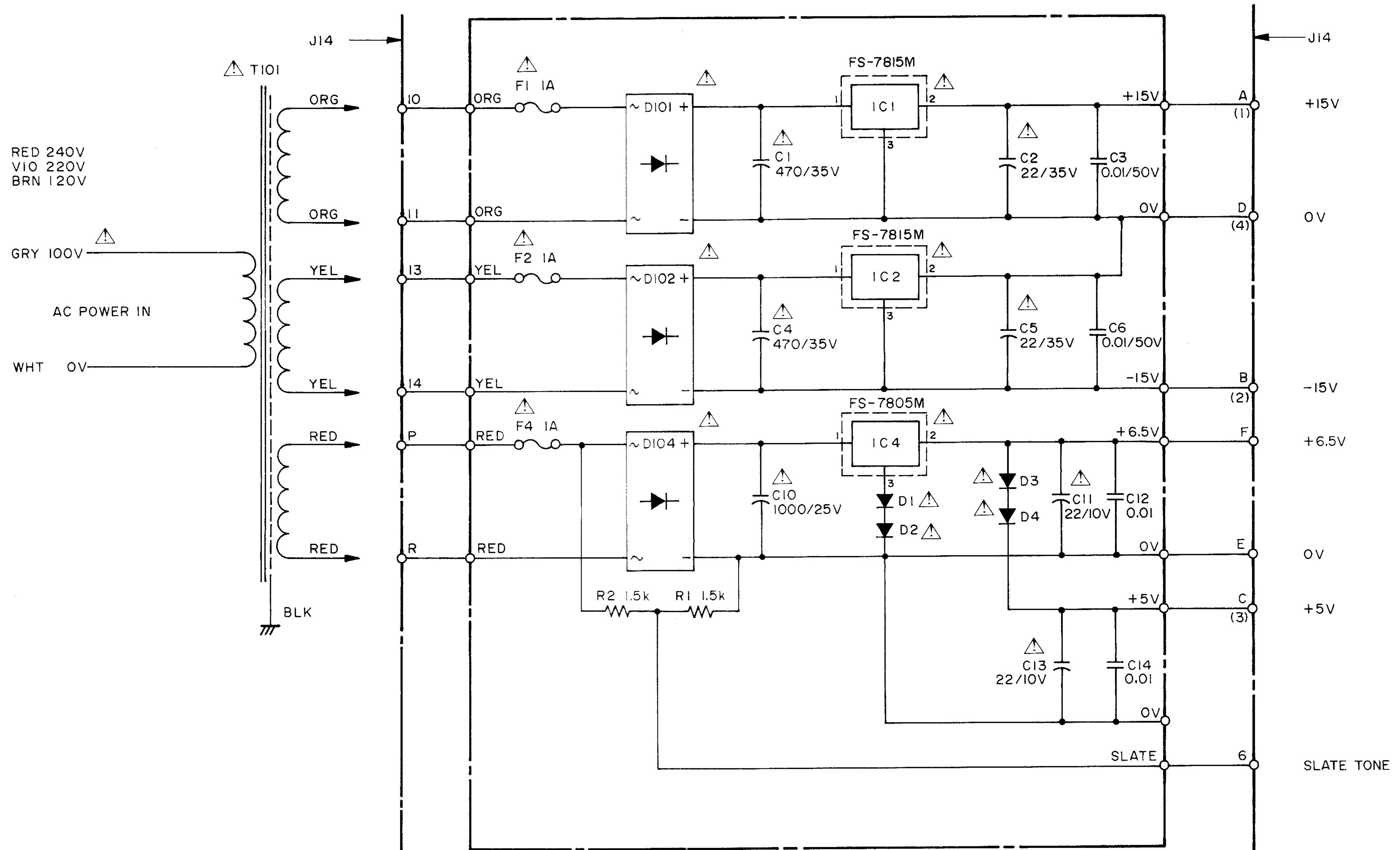

5-3 Model 201C Input Module



5-4 Model 210 Submaster Module



5-5 Model 208 Master/Monitor Module



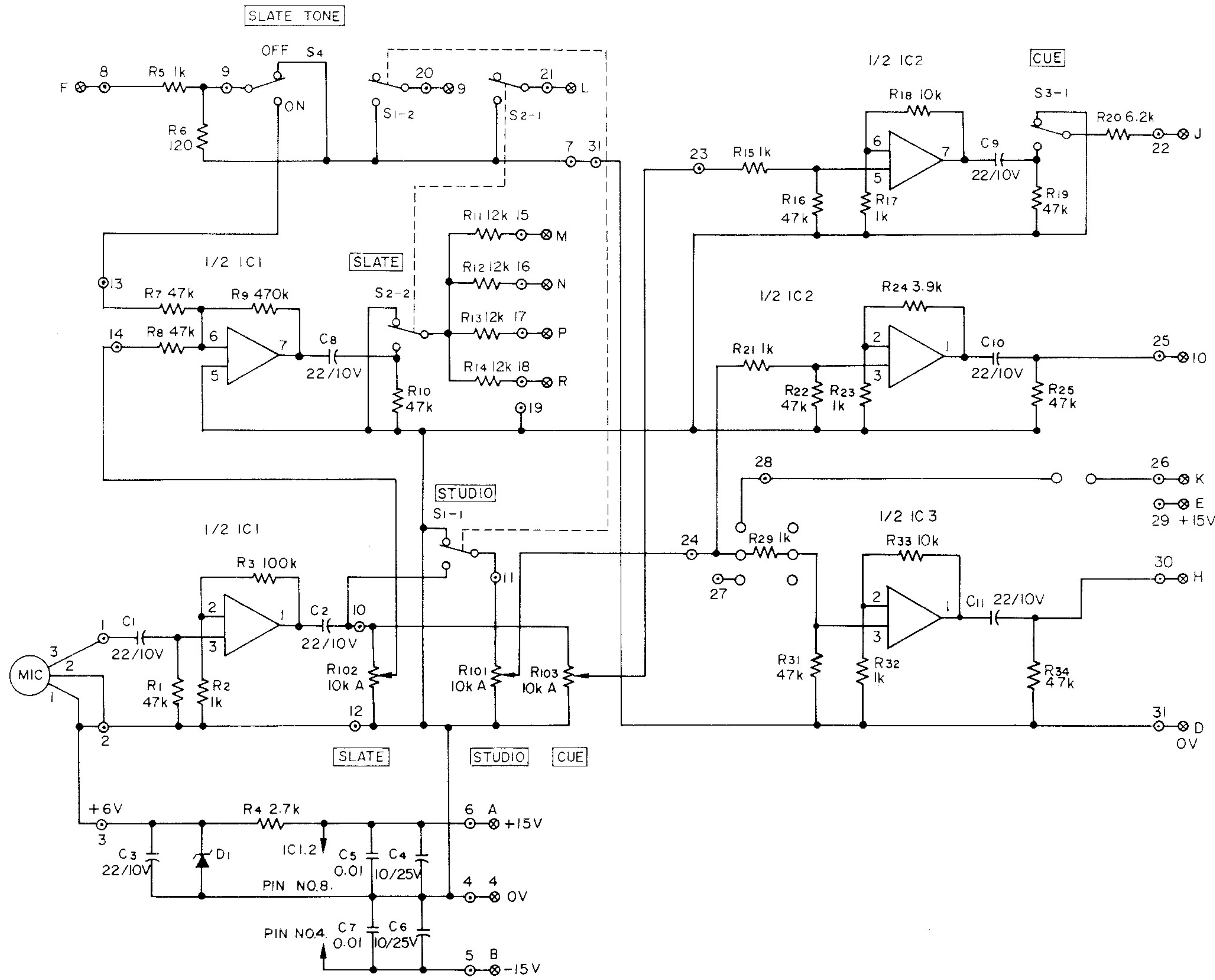

6. IC OPERATION
(PIN DISTRIBUTION AND LOGIC DIAGRAM)

op - amp
NJH4559D Dual comparator

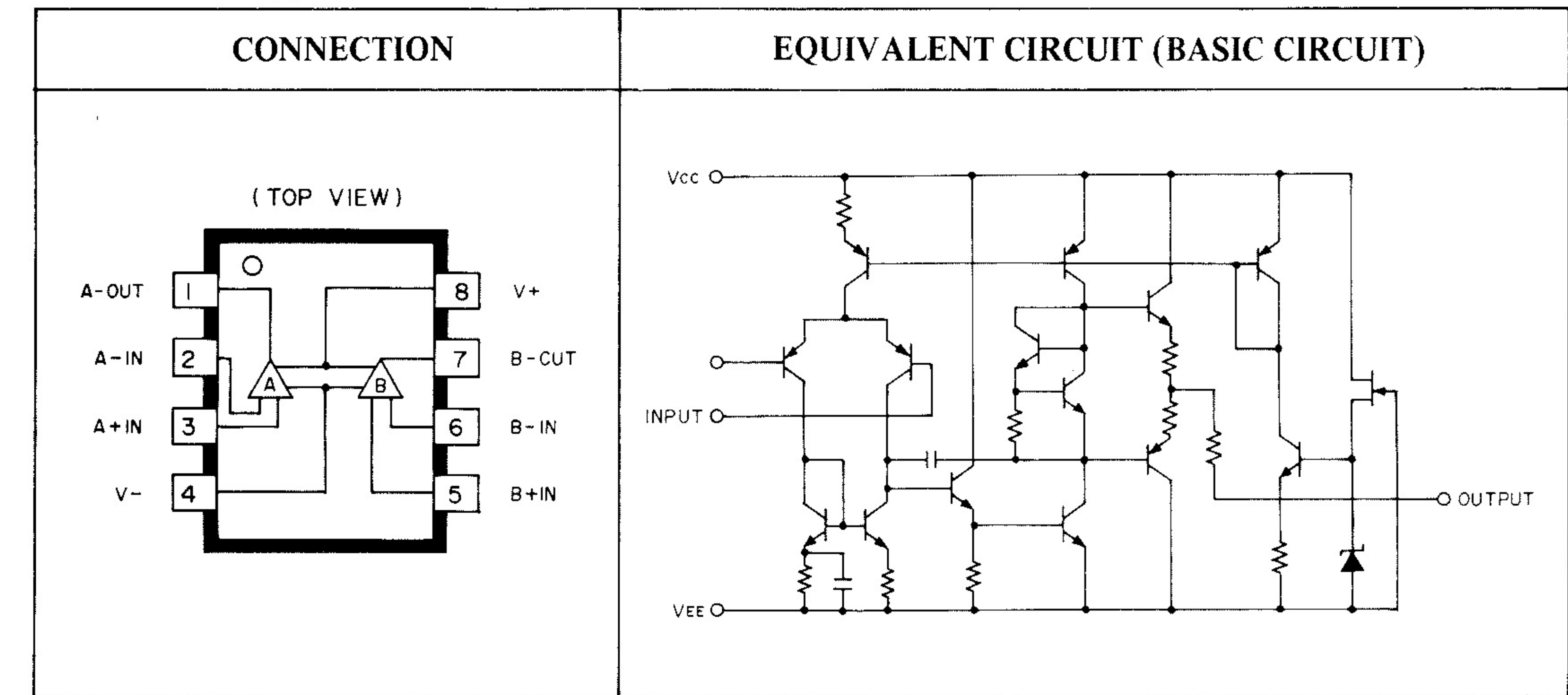

NAND gate
HD7400 Quad comparator

