

TEAC[®]

A-3300S **A-2300S** STEREO TAPE DECK SERVICE MANUAL

ALSO APPLICABLE FOR MODELS
TEAC 2300



A-2300S

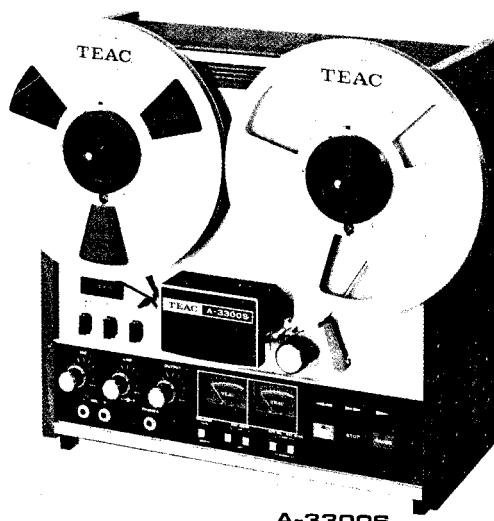

A-3300S

1. GENERAL DESCRIPTION

The TEAC A-3300S/2300S is a semi-professional tape deck for stereophonic recording and playback.

MODEL	TRACKS	TAPE SPEED
A-3300S-2T	2	15ips, 7-1/2ips
A-3300S	4	7-1/2ips, 3-3/4ips
A-2300S-2T	2	7-1/2ips, 3-3/4ips
A-2300S	4	7-1/2ips, 3-3/4ips

This service manual provides adjustment and alignment procedures, schematic diagrams and parts replacement information and the proper procedures for obtaining necessary repair parts.

If adjustments or repair procedures are not clear or seem difficult to accomplish or should you desire more detailed technical information, please contact your nearest TEAC dealer, TEAC Corporation or affiliated Corporations, addresses of which are printed in this manual.

INDEX

1. GENERAL DESCRIPTION
 2. SERVICE DATA
 3. DIMENSIONS
 4. EQUIPMENT REQUIRED
 5. PARTIAL DISASSEMBLY
 6. TAPE TRANSPORT PARTS LOCATION
 7. HEAD REPLACEMENT AND ALIGNMENT
 8. HEAD ALIGNMENT
 9. MEASUREMENT AND ADJUSTMENT
 10. VOLTAGE AND FREQUENCY CONVERSION
 11. MEASUREMENT AND ADJUSTMENT
 12. SERVICING AND MAINTENANCE
 13. PACKING FOR SHIPMENT
 14. WARRANTY
 15. TROUBLE SHOOTING CHART
- EXPLODED VIEW AND PARTS LIST
PRINTED CIRCUIT BOARD PARTS LIST
SCHEMATIC DIAGRAM

2-1. SERVICE DATA

A-3300S

MECHANICAL

TYPE: 4 track 2 channel stereophonic
4 track 1 channel monophonic
2 track 2 channel stereophonic
2 track 1 channel monophonic

HEADS: Erase head x 1 Record head x 1 Playback head x 1

REEL SIZE: 10" maximum NAB reel

TAPE WIDTH: Standard 1/4 inch tape

TAPE SPEED: 2 track 15ips (38cm/s), 7-1/2ips (19cm/s)
4 track 7-1/2ips (19cm/s), 3-3/4ips (9.5cm/s)

MOTORS: Two 6-pole eddy current motors for reel drive
4/8 pole hysteresis synchronous capstan motor

WOW AND FLUTTER: 0.04 at 15ips (WRMS)
0.06 at 7-1/2ips (WRMS)
0.09 at 3-3/4ips (WRMS)
Wow and flutter measured according to weighted (WRMS) NAB standard using TEAC flutter free tape. Above value is measured during playback.

FAST WINDING TIME: Approx. 200 seconds or less with 3600 ft tape

OPERATING POSITION: Horizontal or vertical

POWER REQUIREMENTS: 100 V AC 50/60Hz (108W)

WEIGHT: 44.1 lbs (20 kg) net

ELECTRICAL

TRANSISTORS: 2SC1000(BL) x 4 2SC693(G) x 4 2SC828(S) x 6
2SA564(R) x 2 2SA494(Y) x 4 2SC536(F) x 2
2SC971 x 2 2SC733(Y) x 1 2SD317(P) x 1
2SC1226A(R) x 2 2SD235(Y) x 1

FREQUENCY RESPONSE: Overall from recording INPUT to playback OUTPUT
15ips 30Hz~22kHz \pm 3dB
7-1/2ips ... 30Hz~20kHz \pm 3dB
3-3/4ips ... 30Hz~13kHz \pm 3dB

INPUT: MIC: 0.3 mV/10k Ω
LINE: 0.1 V/100k Ω

OUTPUT: LINE: approx. 0.3 V/10k Ω
HEADPHONE: 0.3 mW/8 Ω

SIGNAL-TO-NOISE RATIO: 15ips 52dB
7-1/2ips ... 52dB (2T), 48dB (4T)
3-3/4ips ... 46dB or higher at playback

BIAS FREQUENCY: 100 \pm 5kHz push-pull oscillator

CROSSTALK REJECTION: 35dB or more, adjacent track at 100Hz

CHANNEL SEPARATION: 45dB or more, channel to channel

ERASE EFFICIENCY: 65dB (2T), 68dB (4T) or more at 7-1/2ips

2-2. SERVICE DATA

A-2300S

MECHANICAL

TYPE: 4 track 2 channel stereophonic
4 track 1 channel monophonic
2 track 2 channel stereophonic
2 track 1 channel monophonic

HEADS: Erase head × 1, Record head × 1, Playback head × 1

REEL SIZE: 7" maximum NAB reel

TAPE WIDTH: Standard 1/4 inch tape

TAPE SPEED: 7-1/2ips (19cm/s), 3-3/4ips (9.5cm/s)

MOTORS: Two 6-pole eddy current motors for reel drive
4/8 pole hysteresis synchronous capstan motor

WOW AND FLUTTER: 0.08% at 7-1/2ips (WRMS)
0.10% at 3-3/4ips (WRMS)
Wow and flutter measured according to weighted
(WRMS) NAB standard using TEAC flutter free tape.
Above value is measured during playback.

FAST WINDING TIME: Approx. 140 seconds or less with 1800 ft tape

OPERATING POSITION: Horizontal or vertical

POWER REQUIREMENT: 100 V AC 50/60Hz (95 W)

WEIGHT: 39.7 lbs (18 kg) net

ELECTRICAL

TRANSISTORS: 2SC1000(BL) x 4 2SC693(G) x 4 2SC828(S) x 4
2SA564(R) x 4 2SA494(Y) x 4 2SC536(F) x 4
2SC971 x 2 2SC733(Y) x 1 2SD317(P) x 1
2SC1226A(R) x 2 2SD235(Y) x 1

FREQUENCY RESPONSE: Overall from recording INPUT to playback OUTPUT
7-1/2ips ... 40Hz~18kHz ±3dB
3-3/4ips ... 40Hz~12kHz ±3dB

INPUT: MIC: 0.3 mV/10kΩ
LINE: 0.1 V/100kΩ

OUTPUT: LINE: approx. 0.3 V/10kΩ
HEADPHONE: 0.3 mW/8Ω

SIGNAL-TO-NOISE RATIO: 7-1/2ips ... 52dB (2T), 48dB (4T) or higher
3-3/4ips ... 48dB (2T), 46dB (4T) or higher at playback

BIAS FREQUENCY: 100 ±5kHz push-pull oscillator

CROSSTALK REJECTION: 35dB or more, adjacent track at 100Hz

CHANNEL SEPARATION: 45dB or more, channel to channel

ERASE EFFICIENCY: 65dB (2T), 68dB (4T) or more at 7-1/2ips

As a result of continuing changes and improvements during the production run, minor differences may be found between early and later machines. Refer to manual change sheets for information concerning modifications.

3. DIMENSIONS A-3300S / A-2300S

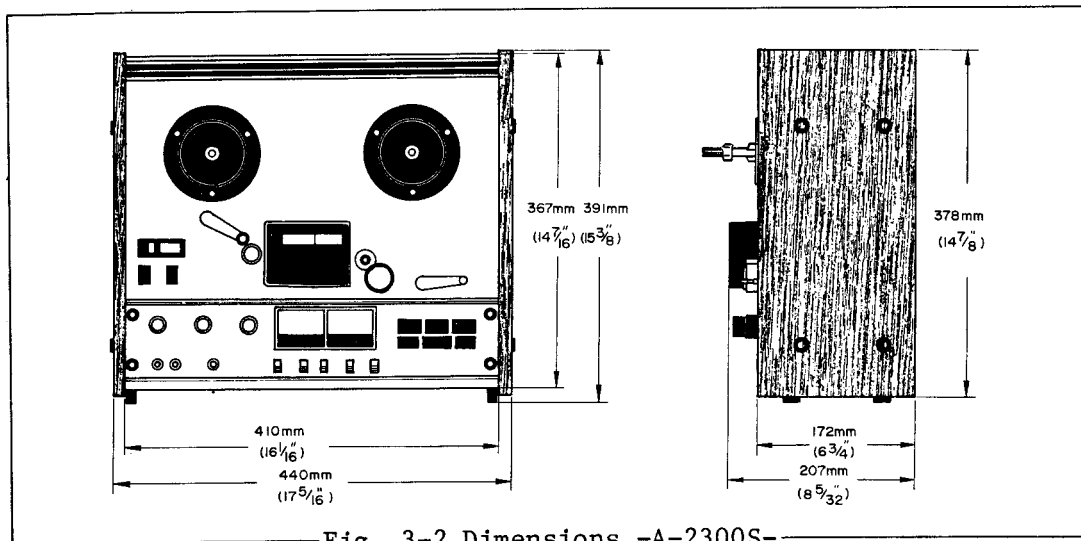
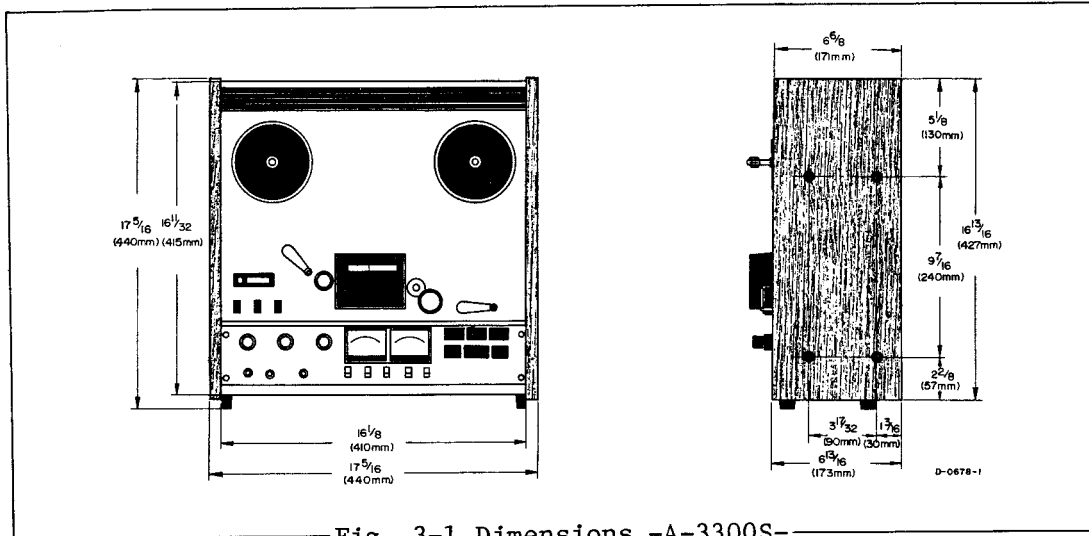

TOOLS FOR TESTING AND MAINTENANCE

A minimum of the next page tools and test instruments are required for measuring and adjusting to obtain optimum performance. Regular maintenance tools will be adequate for those not listed here. If any test instrument listed here is not available, a close equivalent can be used.

4. EQUIPMENT REQUIRED

FOR MECHANICAL MEASUREMENT

SPRING SCALE:	0~4kg (0~8 lbs) #5086025000 0~300g (0~10 oz) #5086026000
TEST TAPE:	TEAC YTT-2004 (15ips) TEAC YTT-2003 (7-1/2ips) TEAC YTT-2002 (3-3/4ips)
FLUTTER METER:	Meguro Model MK665B (preferred) or Sentinel FL-3D-1
DIGITAL FREQ. COUNTER:	Capable of 0 to 5kHz indication
TOOLS:	General, 2 mm nut driver #5086014000, Hex head, allen wrench #5086021000

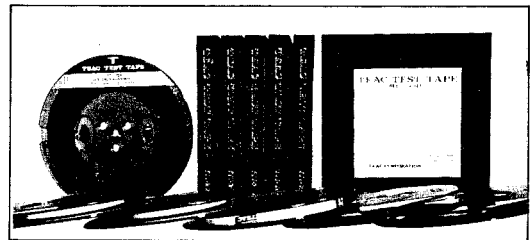
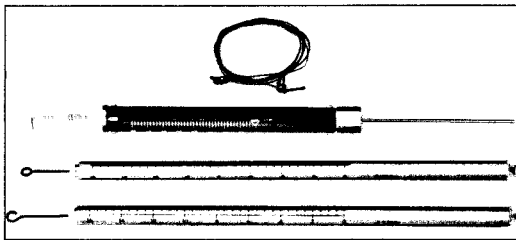

Fig. 4-1 Spring Scale and TEAC Test Tape

FOR ELECTRICAL MEASUREMENT

TEST TAPE:	TEAC YTT-1002 for 3-3/4ips TEAC YTT-1004 for 15ips TEAC YTT-1003 for 7-1/2ips SCOTCH 203 and 150 for test recording
EMPTY REEL:	TEAC RE-702 (2" hub) TEAC RE-701 (4" hub) TEAC RE-1002 (10" reel)
TEST SET:	TEAC M-826A Test Set
BAND PASS FILTER:	TEAC M-260A (1kHz)
VTVM:	hp model 4302B or equivalent
RESISTOR:	Non inductive type 8 Ω /1W
OSCILLOSCOPE:	General purpose

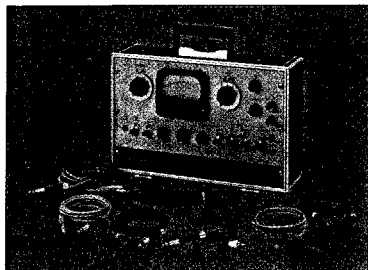

Fig. 4-2 TEAC M-826A

NOTE: Use of the TEAC M-826A test set is recommended. This set incorporates an AC VTVM, Audio Oscillator, Channel Selecting switch, Variable Attenuator, Monitor Speaker and Cables.

TEAC M-826A measures the RMS value of the Voltage (0dB = 0.775V). Characteristics of this test set are similar to the standard VU-meter.

5. PARTIAL DISASSEMBLY

REMOVING WOODEN SIDES AND REAR PANEL

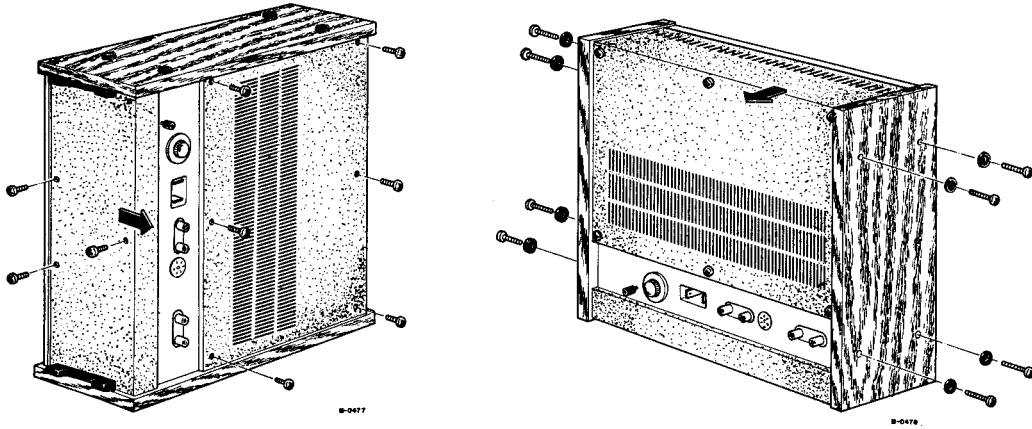

Fig. 5-1 Removing wooden sides and Rear panel

NOTE: All amplifier checks and adjustments can be made from the bottom with the plate removed.

These adjustments should be performed by experienced technicians, and then only when going through the complete test and check procedures on the unit which is being tested.

HEAD ASSEMBLY REMOVAL

- To change the head assembly as a unit,
1. Note the positions of the wires on the circuit board.
 2. Unsolder the wires.
 3. Remove the 2 mounting screws, replace the assembly.
 4. Solder the wires of the new assembly in exactly the same positions.

NOTE: Refer to Fig. 7-2 for wiring

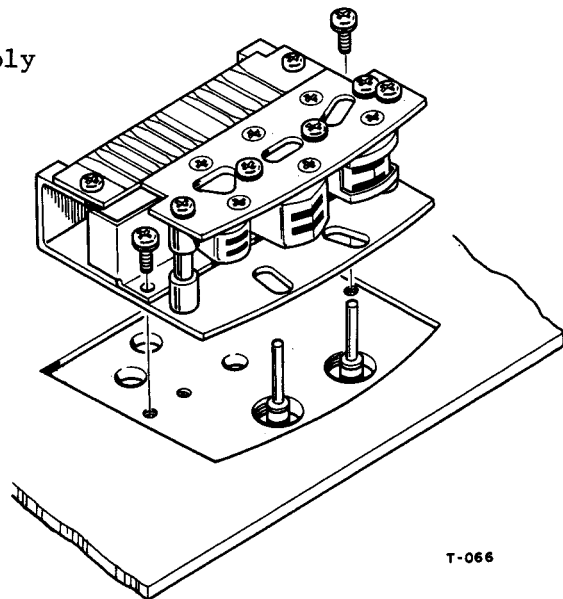

Fig. 5-2 Head Assembly Removal

T-066

REMOVAL OF CAPSTAN MOTOR

1. Remove the 3 screws holding the capstan motor.
2. Unsolder the 6 wires connecting the capstan motor.
3. Remove the 4 screws holding the capstan motor.
4. Loosen the 2 set screws (hex head) in pulley and lift off pulley.

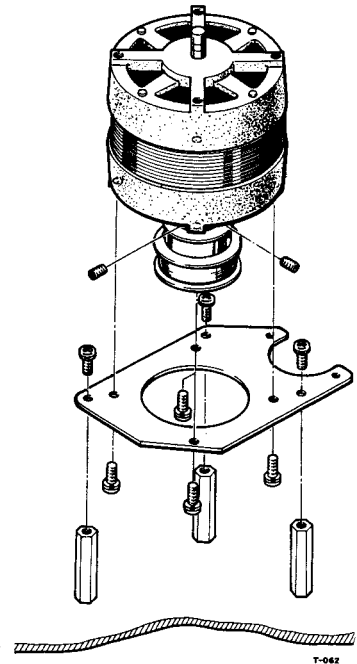

Fig. 5-3 Capstan Motor Removal

REMOVAL OF CAPSTAN ASSEMBLY

1. Unscrew capstan cover (front panel).
2. Remove 2 screws from rear bracket, allow bracket to drop toward floor of case.
3. Remove capstan belt.
4. Loosen 2 screws in capstan assy flywheel. Remove flywheel.
5. Remove 3 screws in capstan assy.
6. Gently move capstan assy up and down until it slides out of panel.

NOTE: A clearance of 0.01" must be maintained between the flywheel and the capstan assembly.

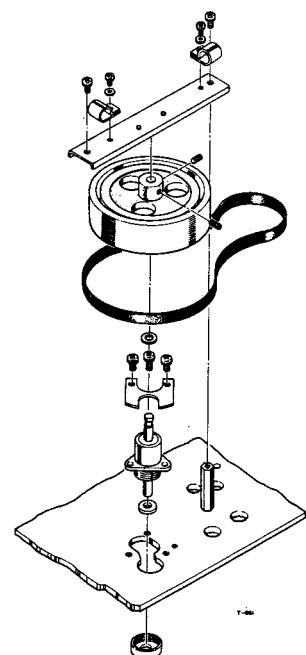

Fig. 5-4 Capstan Assembly Removal

REMOVAL OF TENSION ARMS LEFT & RIGHT

See illustration for complete disassembly instructions.

IMPORTANT

After reassembly check clearance to ascertain that arm moves freely and is not binding.

CAUTION

Do not over-tighten screws holding right tension arm. Insulating spacer and micro-switch are easily broken by excess pressure.

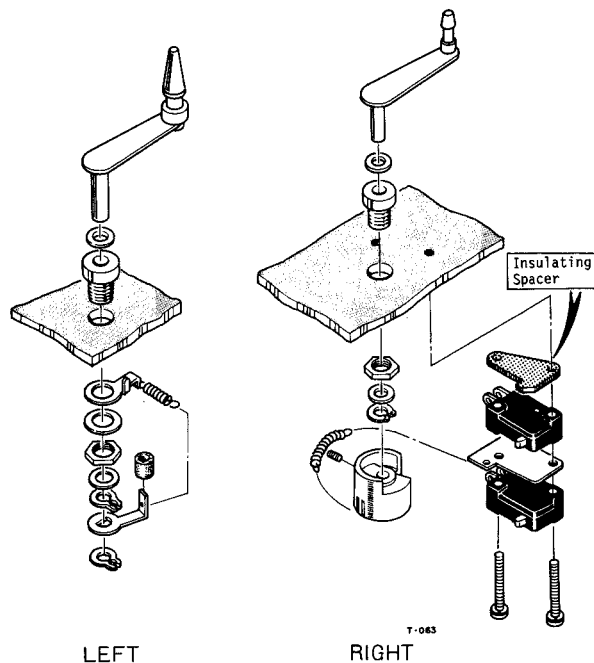

REMOVAL OF REEL MOTOR ASSEMBLY

1. Loosen 2 hex screws in brake drum, lift off brake drum.
2. Remove 4 screws securing the brake assembly to the motor.
3. Remove reel turntable, remove 4 screws securing motor to front panel.

NOTE: Reel motor assemblies are mirror images of each other, these assemblies are not interchangeable.

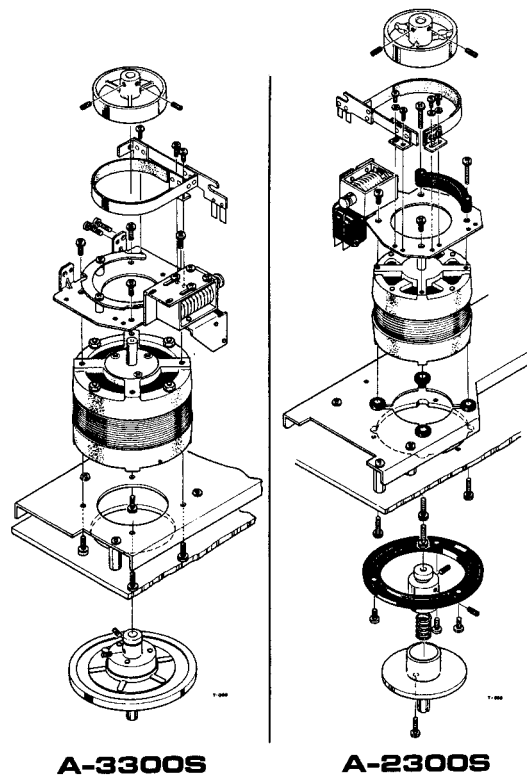
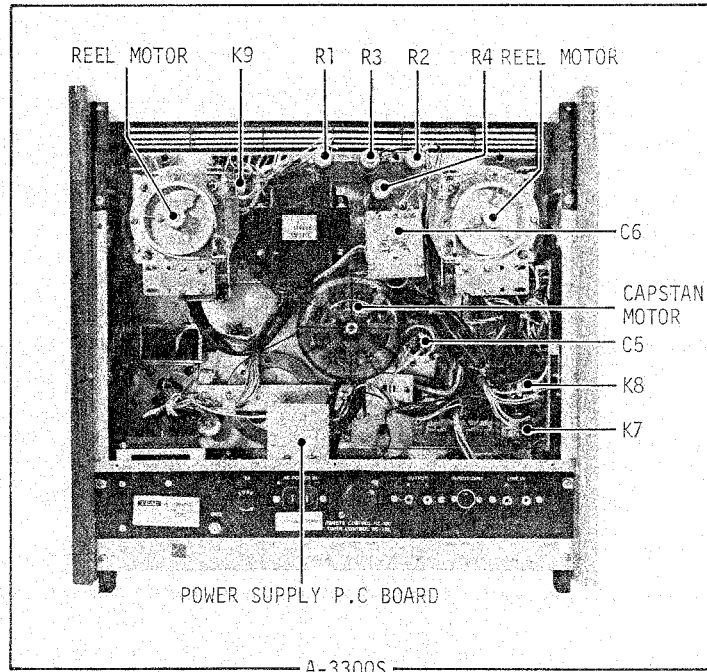
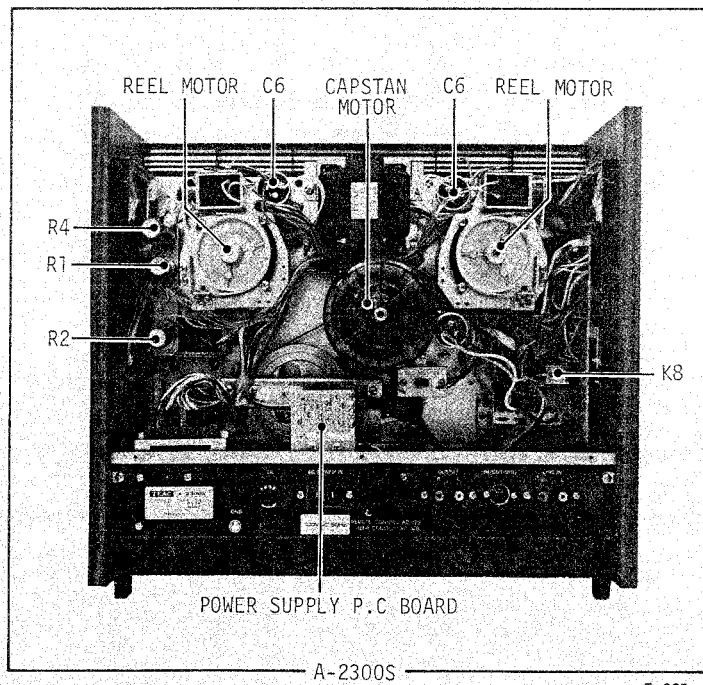

Fig. 5-5 Reel Motor Removal

6. TAPE TRANSPORT PARTS LOCATION -REAR VIEW-



-REAR VIEW-



T-065

NOTE: For ordering parts, refer to the exploded view of the PARTS LIST. An accompanying listing provides the correct part numbers.

7. HEAD REPLACEMENT AND ALIGNMENT -MECHANICAL-

HEAD REPLACEMENT

NOTE: Head alignment is adjusted at the factory to very critical tolerance. Normally HEAD ASSEMBLY replacement will require only minor alignments or adjustments. Complete readjustment will be necessary after a head is replaced. The adjustments are explained on the next page.

Procedures

To replace a single head, a special 2 mm nut driver is required. Remove the 2 nuts on the defective head through the access hole provided, this releases the head from the mounting plate. Note the position of the wires on the circuit board. Connect the new head in the same manner. Replace the nuts securing the new head to the plate, perform head alignment before operation.

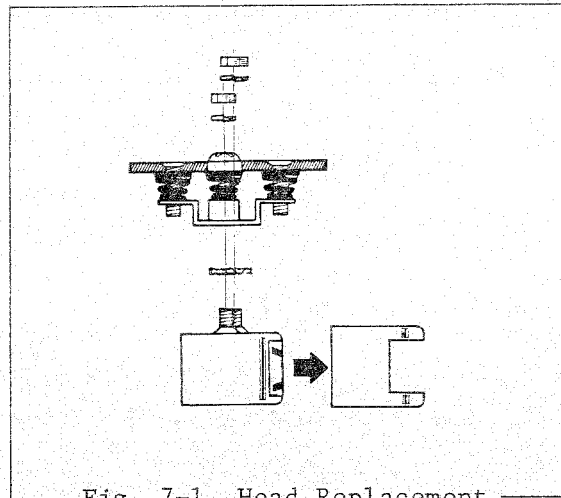

Fig. 7-1 Head Replacement

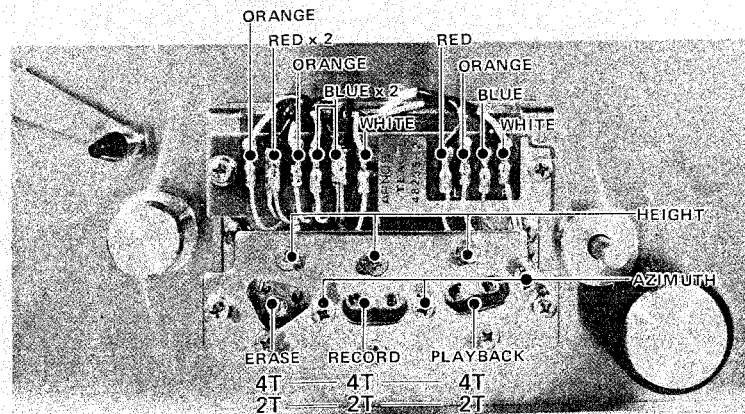

Fig. 7-2 Head Adjustment Screws and Wiring.

8. HEAD ALIGNMENT

HEAD ALIGNMENT (4 TRACK)

RECORD HEAD: The record head pole should be above the edge of a threaded tape by the width of a thin pencil line.

PLAYBACK HEAD: The forward playback head pole should be even with the top of a threaded tape.

ERASE HEAD: Erase section should be a heavy pencil line above.

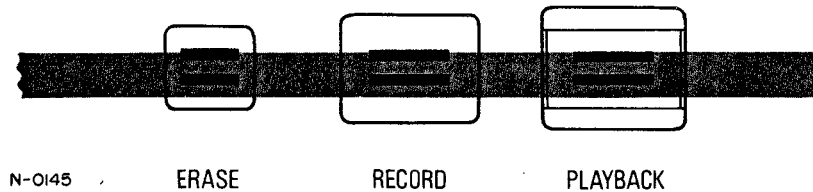

HEAD ALIGNMENT (2 TRACK)

RECORD and ERASE head are centered on the tape.
PLAYBACK head forward section is a heavy pencil line above the edge.

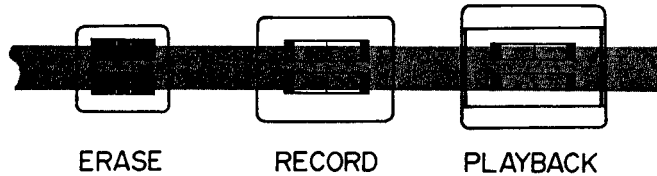

Fig. 8-1 Head configuration and Alignment

MECHANICAL MIS-ALIGNMENT OF THE HEADS -EXAMPLES-

ALIGNMENT - The physical positioning of a tape head relative to the tape itself. Alignment in all respects must conform to rigid requirements in order for a unit to function properly.

AZIMUTH - The angle of a tape head pole-piece slot relative to the direction of tape travel.

NOTE: In order for a tape unit to work at its best, with its own tapes as well as ones made on other units, its play and record heads must be aligned to correct the 4 possible errors as illustrated to the right.

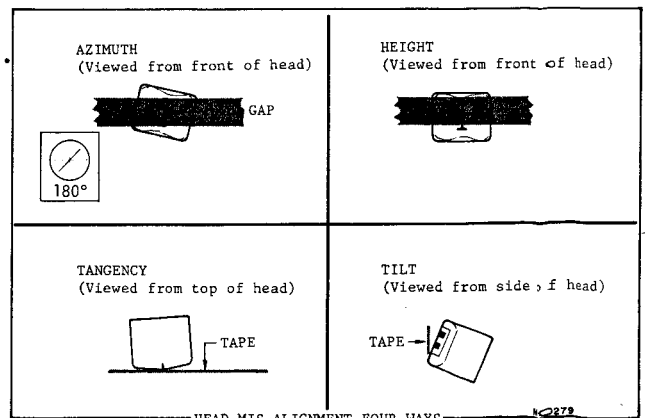

Fig. 8-2 Head Mis-Alignment -Example-

9. MEASUREMENT AND ADJUSTMENT -MECHANICAL-

The TEAC A-3300S/A-2300S uses a highly reliable 3 motor drive system and should require a minimum of mechanical maintenance or adjustment. These adjustments are made at the factory. Readjustment should only be required after many hours of operation or component replacement.

PINCH ROLLER PRESSURE

NOTE: Pinch roller pressure is supplied by the pinch roller spring arm and it is most important that the solenoid plunger be fully bottomed before taking pressure measurement.

1. Load tape or block the shut-off arm in the "ON" position.
2. Attach a suitable spring scale to the pinch roller shaft.
3. Place the unit in the PLAY mode (▶), and holding the spring scale as illustrated, slowly draw it away from the pinch roller.
4. Do not allow the string to rub against the pinch roller.
5. Note the reading on the spring scale at the instant the pinch roller stops rotating.
6. The scale should indicate 2.1~2.3kg. Optimum value is 2.2kg.
7. If adjustment is necessary, loosen the 3 screws on the capstan solenoid and position the solenoid for optimum pressure.
8. Adjust solenoid-limit position so that the gap between capstan shaft and pinch roller is approximately 7 mm when solenoid is not actuated. Limit is adjusted by loosening the mounting screw (A), Then sliding limit until proper gap is obtained.

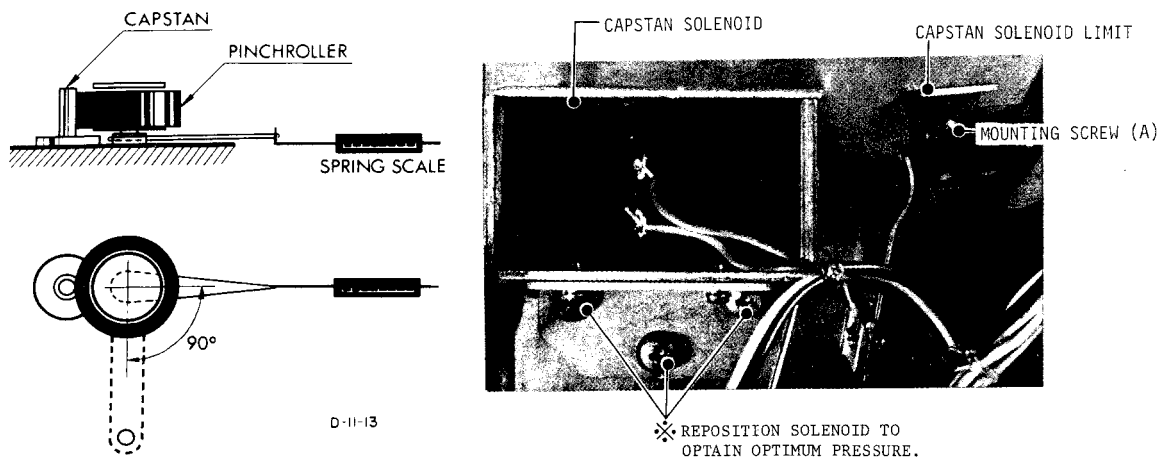

Fig. 9-1 Pressure Measurement and Adjustment Locations

TORQUE MEASUREMENT PROCEDURE

For Adjustment Locations refer to the following page.

BACK TENSION

Set REEL switch to the LARGE position (A-3300S)

1. Load tape or block the shut-off arm in the ON position.
2. Place an empty 7" reel with a 2" diameter hub on left reel table.
3. Rotate the reel and wind several turns of string around the hub. Attach spring scale to string.
4. Place the unit in the (▶) play mode.
5. Pull the scale away from the reel against the motor torque, with a steady smooth motion.
6. Note the scale reading while it is in steady motion.
7. Make sure the string does not rub against the reel flanges.
8. The reading should be approximately 300~320 g-cm (A-3300S only). (180~210 g-cm for SMALL position on REEL switch or on A-2300S).

TAKE-UP TORQUE

1. Place the empty reel and attached spring scale on the right reel table.
2. Place the unit in the (▶) play mode.
3. Allow the rotation of the reel to slowly draw the scale toward the hub.
4. Hold the spring scale with enough force to allow a steady reading.
5. It should be approximately 780~820 g-cm for A-3300S. (380~400 g-cm for SMALL or for 2300S).

REWIND BACK TENSION

1. Load a full 1,800ft reel of tape (7-1/2") on the right reel table.
2. Place an empty reel with 2" hub on the left reel table.
3. Place the unit in the fast rewind mode.
4. At this time observe the right tension arm. The arm should move approximately 1" to the right and remain there.
5. Check value of R-4 (600 Ω) if movement is extremely incorrect. (Located directly below R-1, R-2 and R-3).

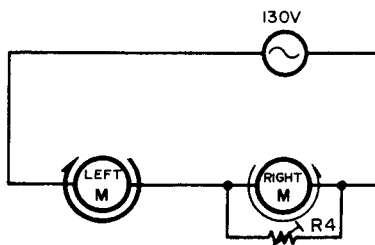

TORQUE ADJUSTMENT

All Torque and Tension Measurements must be made with the automatic shut-off switch blocked to the "ON" position.

1. Measure the back tension of the left reel motor and the take-up torque of the right reel motor.
2. Adjust R1: LARGE (SMALL) reel TAKE-UP torque
 R2: LARGE reel BACK TENSION
 R3: SMALL reel BACK TENSION
3. Back tension and take-up torque to exact specified limits.
 Refer to preceding page 9-2 for TORQUE MEASUREMENT PROCEDURE section.

NOTE: Adjustments will interact. Several adjustments may be required to bring both motors within specifications.

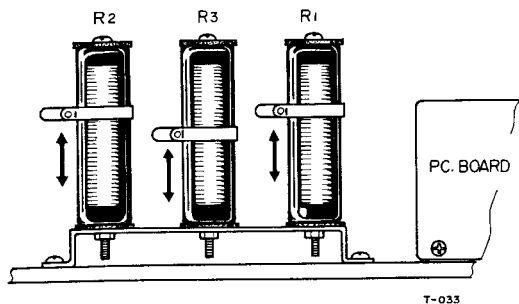

A-3300S

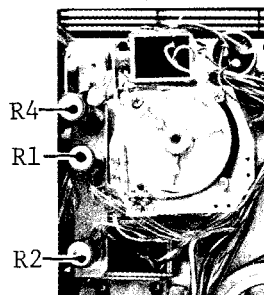

A-2300S

	A-2300S	A-3300S
R1	TAKE UP	TAKE UP (LARGE)
R2	BACK TENSION	BACK TENSION (LARGE)
R3	-----	BACK TENSION (SMALL)
R4	BACK TENSION FOR FAST FORWARD	

Fig. 9-2 Adjustment Parts Location

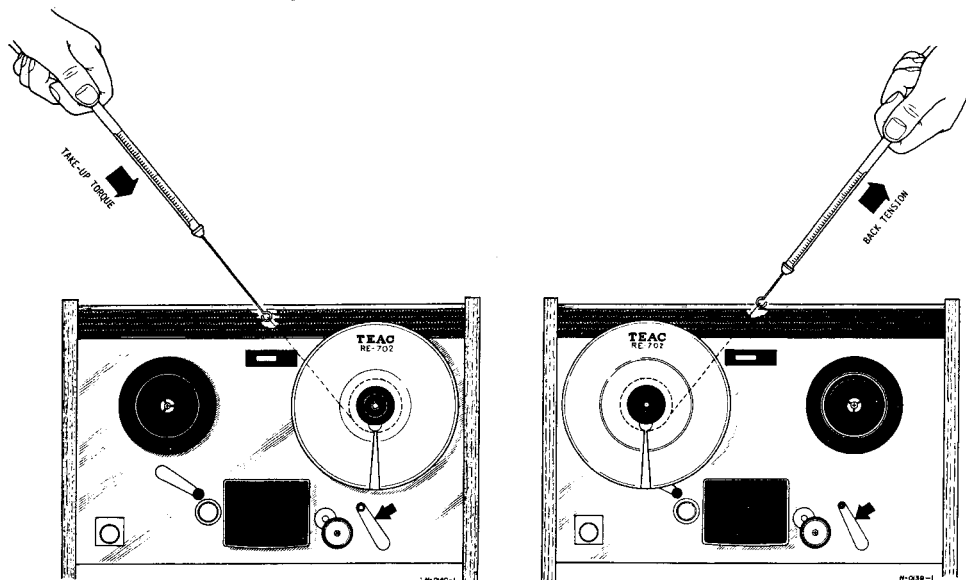

Fig. 9-3 Torque Measurement

BRAKE TORQUE

The brake torque is actuated mechanically. Pressure is set by the variable spring force. While making this measurement and adjustment, be careful not to bend the brake bands. As brake torque will change with cleaning, brake drums and brake shoes should be cleaned only when absolutely necessary. If cleaning is required, use TEAC cleaner TZ-261B only. After cleaning operate the machine for a month of normal operation before performing the procedures below.

Brake adjustments are made with "NO" power connected to the equipment.

Procedure for Check and Adjustment

1. Place an empty 2" hub reel on the left reel table, and fasten one end of a 30" length of string to the reel anchor.
2. Wind several turns of string counterclockwise around the hub and attach a suitable spring scale to the free end of the string.
3. Take a reading only when the reel is in steady motion since the force required to overcome static friction will produce a false, excessively high initial reading.
4. The reading should be 1.8 kg-cm \pm 0.2 (25 oz-inch).
5. If adjustment is required, loosen the 2 screws shown and position the brake for optimum torque.
6. The adjustment of the right brake is the same, with the exception that rotations are clockwise.

NOTE: The difference in readings between the right and left brakes should be kept within 100 g-cm (1.4 oz-inch).

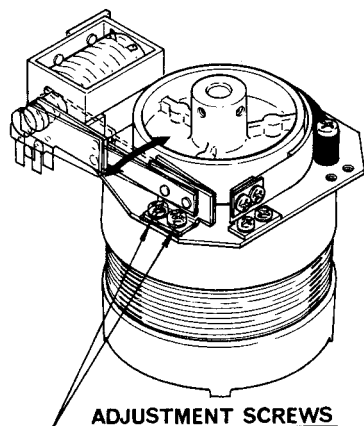

A-2300S

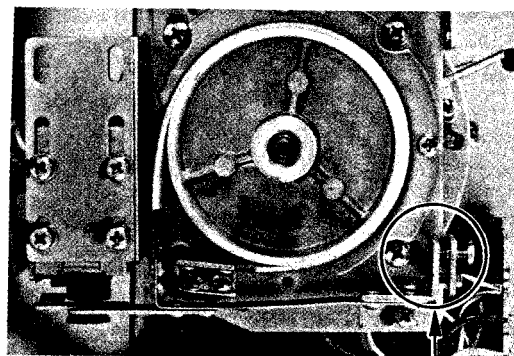

A-3300S

Fig. 9-4 Adjustment Location

REEL HEIGHT ADJUSTMENT

Reel height adjustment is required only if a motor has been replaced or if tape rubs excessively against the side of the reel. Adjustment is accomplished by the FINE ADJUSTMENT screw in the reel turntable. Reel turntable should be adjusted using standard 7" reels. With a tape threaded on the machine, position the reel-height for smooth tape travel.

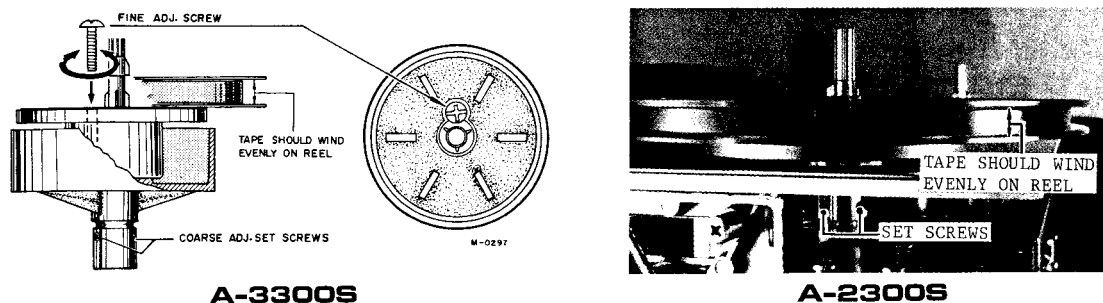

Fig. 9-5 Reel Height Adjustment

FLUTTER

Flutter should be measured in playback mode using a TEAC flutter free tape YTT-2004, 2003 and Meguro model MK665B flutter meter. Measurement of flutter should be made in accordance with NAB standards.

Values obtained with different standards or equipment cannot be compared.

Flutter should not exceed.

15ips:	0.15%	(RMS)
7-1/2ips:	0.18%	(RMS)
3-3/4ips:	0.20%	(RMS)

These figures apply to any tape position and direction (such as full take-up reel, full supply reel or about mid point).

TAPE SPEED

The tape speed should be measured using TEAC flutter free tape, model YTT-2004, 2003, 2002. These tapes contain a highly accurate 3 kHz tone. Connect a digital frequency counter to either line OUTPUT jack. The indicated frequency should be 3kHz \pm 1% for all speeds.

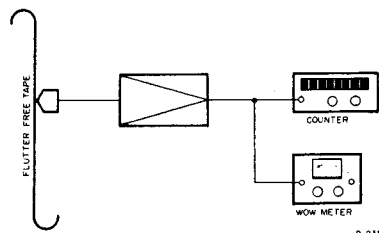

Fig. 9-6 Test Equipment Set-Up

10. VOLTAGE AND FREQUENCY CONVERSION

Unit must be set to the power line frequency available. Improper frequency setting will result in a 20% error between the tape speed and reel motors torque. [US model is preset to 117V AC and 60 Hz. No frequency conversion is required.]

NOTE: If it should be necessary to convert the A-3300S/A-2300S deck to operate from a power source of different voltage or frequency, it may be easily accomplished as follows:

Voltage Conversion:

The A-3300S/A-2300S may be set for 100 or 117 volts only. See illustration Fig. 10-1 (Voltage Conversion) and change wiring as shown.

Frequency Conversion:

1. Remove the power cord and all connecting cables.
2. Take off tape deck rear cover by removing the 6 screws holding it.
3. To convert the unit from 50 to 60 Hz operation reposition the capstan belt as shown in the illustration below.
4. Frequency selector slide switch inside the rear of the tape deck must be switched to the frequency of the power line.
5. Reinstall rear cover.

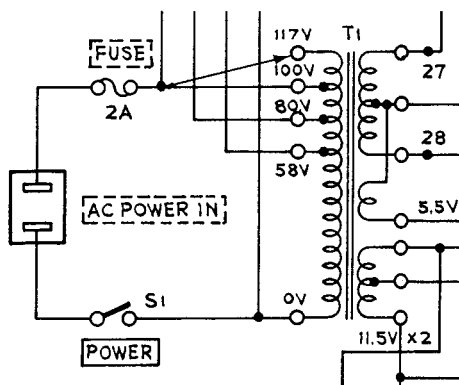

Fig. 10-1 Voltage Conversion

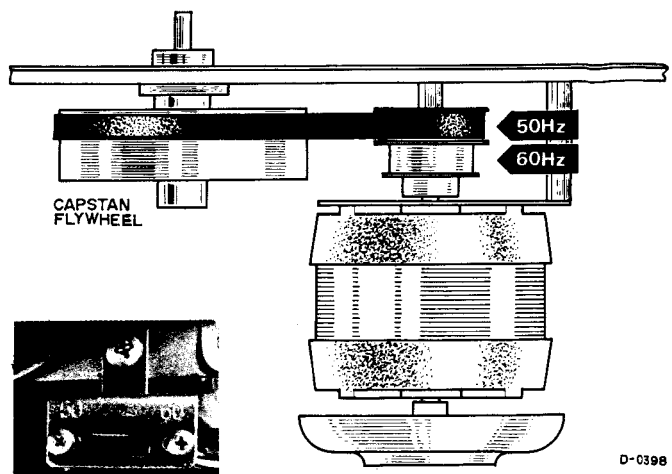

Fig. 10-2 Frequency Conversion

ELECTRICAL ADJUSTMENT GENERAL NOTICE

Before performing maintenance on this unit, thoroughly clean and demagnetize the entire tape path. TEAC maintenance equipment to be used:

- TEAC TZ-261 A/B for cleaning
- TEAC TZ-255 A/B for oiling
- TEAC E-1 for demagnetizing

It is important that the unit be set to the proper voltage and frequency for your locality.

TEAC specified standard test tapes and test equipment must be used when performing maintenance to insure reliable results.

Procedures for checks and adjustments, unless otherwise indicated, are for the left channel at a tape speed of 7-1/2ips. The same procedures are to be applied to the right channel and again for both channels at 15ips or 3-3/4ips.

Power supply check and adjustment:
Check the voltage at VR-1 and adjust to +23V DC if required. (Refer to control board on the TAPE TRANSPORT CIRCUIT DIAGRAM.)

All amplifier check and adjustments can be made from the bottom with the plate removed.

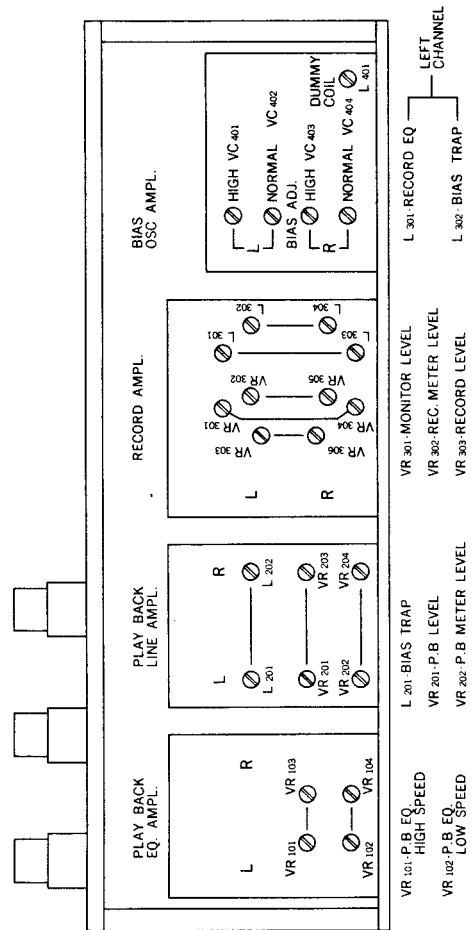

Adjustment Location

ADJUSTMENT SEQUENCE

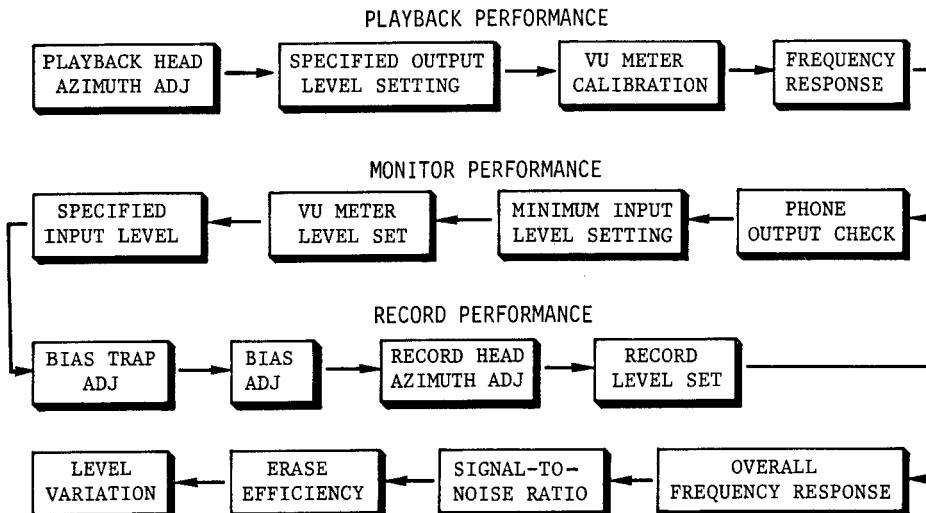

11. MEASUREMENT AND ADJUSTMENT

-ELECTRICAL-

PLAYBACK HEAD AZIMUTH ADJUSTMENT

NOTE: After head replacement or if, during playback, a slight pressure on the heads results in a rise of the reading of the Test Set (M-826A), head azimuth adjustments should be accomplished.

Coarse Adjustment:

1. Connect a level meter to either OUTPUT jack.
2. Thread a TEAC test tape YTT-1003 on the unit.
3. Play the 15 kHz test tone in section 2 of the test tape.
4. Slowly rotate the azimuth screw until maximum indication is obtained on the Test Set.

Fine Adjustment:

NOTE: It is absolutely essential to accomplish the coarse adjustment before performing the fine adjustment to avoid phase errors larger than 45° . After coarse adjustment, do not make large corrections, turn azimuth screw $1/4$ turn or less.

5. Connect the test equipment as shown in Fig. 11-1 below.
6. Play a 50 Hz~7.5 kHz signal and adjust the azimuth screw until the oscilloscope shows that the signals are less than 45° out of phase.
7. Secure the screw with a drop of LOCTITE.

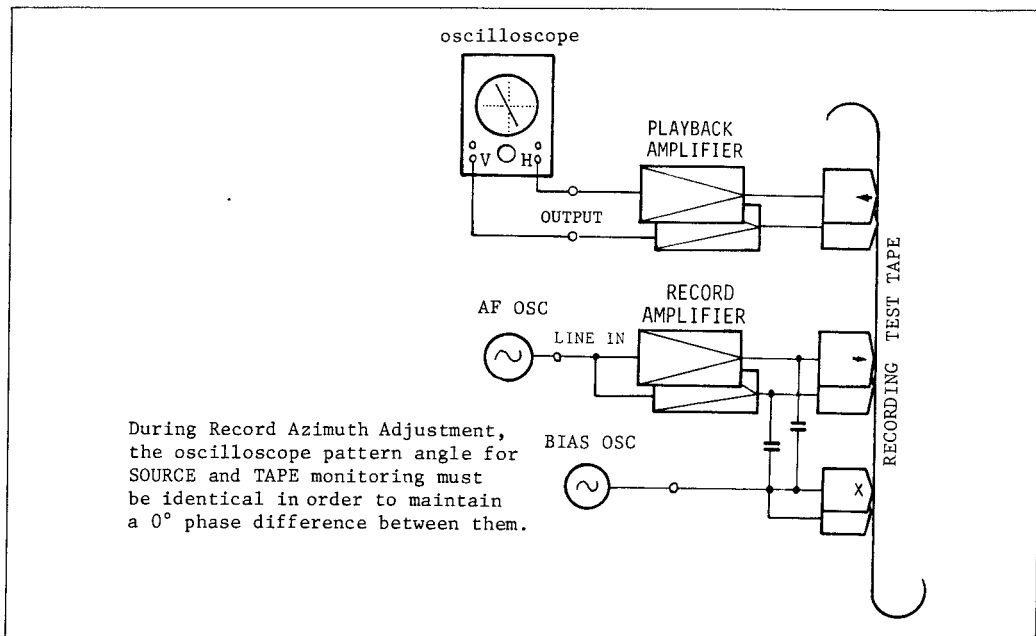

Fig. 11-1 Fine Adjustment Set-up
-Head Alignment-

SPECIFIED OUTPUT LEVEL SETTING

NOTE: Connect a $10k\Omega$ load to the OUTPUT jacks for all audio measurements when not using TEAC Test Set (M-826A).

1. Place the MONITOR switch to the TAPE position.
2. Turn the OUTPUT control fully clockwise.
3. Thread TEAC test tape YTT-1003 on the unit. Operate at 7-1/2ips. This tape will apply a 400 Hz signal at operating reference level (1% of the THD level).
4. Adjust VR-201/203 to obtain an OUTPUT of -2 dB at the OUTPUT jacks.
5. Align the reference marks of controls so that they are at the 2 o'clock position. This will give approximately -8 dB at the OUTPUT jacks.
6. Readjust VR-201/203 for a -8 dB output level at OUTPUT jacks.

IMPORTANT: This is the specified output level setting. Do not disturb this setting until the remaining adjustments have been completed.

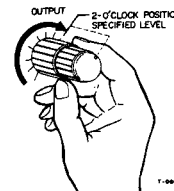

VU METER CALIBRATION

7. Play the 400 Hz tone (1% THD) in section 1 of the test tape.
8. With MONITOR switch at TAPE position, adjust VR-202/204 for a reading of 0 VU on the VU meter.

FREQUENCY RESPONSE

1. Place Tape SPEED switch in LOW position.
2. Thread a TEAC test tape YTT-1003 on the unit.
3. Compare the readings obtained on the Test Set with the response limits given in Fig. 11-2.
4. If adjustment is required, adjust VR-102/104 at Low speed.
5. Place Tape SPEED switch in HIGH position.
6. Thread a TEAC test tape YTT-1004 on the unit.
7. Repeat step 3. Check for best frequency response limits.
8. If adjustment is required, adjust VR-101/103 at HIGH speed.

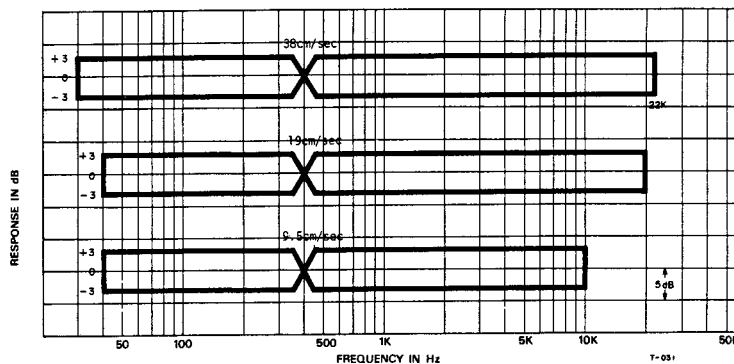

Fig. 11-2 Frequency Response -Playback-

PHONE OUTPUT CHECK

1. Place OUTPUT control at the Specified Level Setting (400 Hz signal at -8 dB).
2. Connect an 8Ω non-inductive resistor across headphone output. Connect Test Set across the resistor.
3. Test Set should indicate $-24\text{ dB} \pm 2\text{ dB}$.

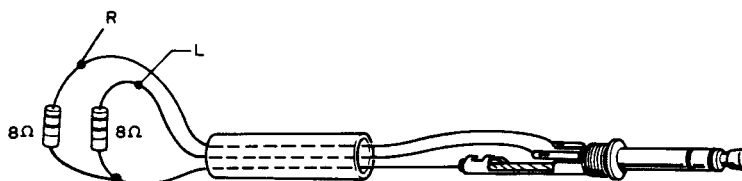

Fig. 11-3 Headphone Connecting Resistor

MINIMUM INPUT LEVEL SETTING

LINE Input:

1. Connect an AF oscillator to the LINE IN jacks.
2. Place MONITOR switch in SOURCE, EQ switch, BIAS switch in HIGH position.
3. Apply a 400 Hz signal -18 dB to the LINE IN jacks.
4. Turn LINE control fully clockwise, adjust VR-301/304 to obtain the specified output level of -8 dB at OUTPUT jacks.

MIC Input:

[This is a check only. No adjustments are to be made.]

5. After adjusting VR-301/304, apply a 400 Hz signal at -70 dB to the MIC IN jacks.
6. Rotate the MIC controls fully clockwise. It should give an output of -8 dB (specified output level).

NOTE: Return MIC controls fully counterclockwise (CCW) to prevent noise insertion during the following steps.

VU METER LEVEL SET

Verify if OUTPUT controls are at the specified output level.

1. Place the MONITOR switch to the SOURCE position.
2. Apply a 400 Hz signal at -8 dB to LINE IN jacks.
3. Adjust VR-302/305 for 0 VU (± 0.5) on the VU meter.

SPECIFIED INPUT LEVEL SET

1. Apply a 400 Hz signal at -8 dB to the LINE IN jacks.
2. Adjust the LINE control for -8 dB at the OUTPUT jacks.

NOTE: Do not disturb the specified input level position of these controls until the remaining checks and adjustments are completed. The difference between the channels must not exceed ± 2 dB as indicated on the test set. If they are not within limits, check the amplifier gain and the LINE control settings.

Before making any adjustments on the record amplifier, be sure that all tests in the HEAD ALIGNMENT, PLAYBACK and MONITOR PERFORMANCE sections have been accomplished and that all levels are correct.

TEAC A-3300S/2300S is factory set with SCOTCH type 203 (HIGH) and SCOTCH type 150 (NORMAL) tape.

BIAS TRAP ADJUSTMENT

NOTE: The bias trap tank circuit keeps the bias signal from reaching the record and monitor amplifier and under normal "no signal" conditions, voltage should not be present at the OUTPUT jacks.

1. Place BIAS switch in HIGH position, MONITOR switch in TAPE position and RECORD MODE switches to "ON". Place tape mode switch at the PAUSE position. Depress RECORD and (▶) buttons.
2. Connect a VTVM or oscilloscope to the junction of C-312/L-302, C-330/L-304 (Right channel).
3. Adjust L-302, L-304 for minimum reading.
4. Adjust L-201, L-202 for the minimum leakage point at the OUTPUT jacks. (on the PLAYBACK LINE AMPL.)

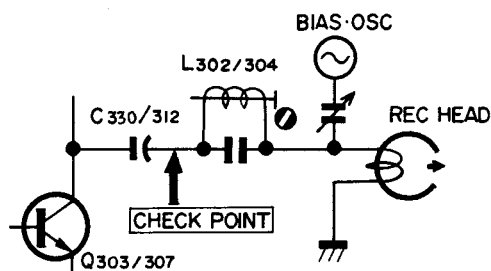

M-0448-1

Fig. 11-4 Bias Trap Check Point

BIAS ADJUSTMENT

NOTE: Adjust bias traps (above) before proceeding. The following adjustments are only made at 7-1/2ips (19 cm/s) tape speed. The bias oscillator frequency is 100 kHz (± 5 kHz).

NORMAL position

1. Thread record test tape SCOTCH 150 on the unit.
2. Place the REC BIAS switch to NORMAL and place the unit in the record mode.
3. Place the MONITOR switch in the TAPE position.
4. Apply a 400 Hz signal at -8 dB to the LINE IN jacks.
5. Adjust capacitor VC-402/404 for a peak on the test set, then turn the capacitors clockwise until a decrease of 0.5 dB is obtained.

HIGH position

1. Thread record test tape SCOTCH 203 on the unit.
2. Place the REC BIAS switch to HIGH position.
3. Adjust VC-401/403 as in NORMAL position.

RECORD HEAD AZIMUTH ADJUSTMENT

Coarse Adjustment:

NOTE: The effect of turning the azimuth screw will not immediately register on the test set. A slight delay will be noticed. Therefore, the screw must be rotated slightly with a pause to see the effect.

1. Connect a level meter to the OUTPUT jack and an AF oscillator to the LINE IN jack, then set the AF oscillator to 10 kHz.
2. Make certain that the LINE controls are at the specified input level positions.
3. Place the MONITOR switch to SOURCE and adjust the AF oscillator to obtain a signal of 15 dB below the specified output level. (The test set will indicate -23 dB.)
4. Thread a record test tape on the unit.
5. Place the MONITOR switch in the TAPE position.
6. While recording adjust the azimuth screw for maximum indication on the test set.

Proceed to the next page "Fine Adjustment"

Fine Adjustment:

NOTE: It is absolutely essential to accomplish the coarse adjustment before performing the fine adjustment to avoid phase error larger than 45°.

7. Connect the test equipment as shown in Fig. 11-1.
8. Apply 7.5 kHz signal at -23 dB to the LINE IN jacks and record this signal.
9. Carefully adjust the azimuth screw until the oscilloscope shows the signal to be in phase.
10. Secure the screw with a drop of LOCTITE.

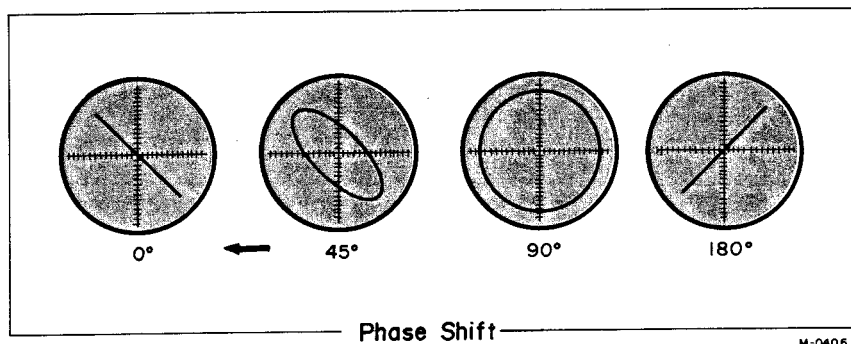

Fig. 11-5 Phase shift

Refer to Fig. 11-1 Fine Adjustment Set-Up (Playback)

RECORD LEVEL SET

NOTE: The OUTPUT control must be at the specified output level position (-8 dB at OUTPUT jacks), and the LINE INPUT controls at the Specified Input Level Setting.

1. Apply a 400 Hz signal at -8 dB to the LINE IN jacks.
2. Thread record test tape SCOTCH 150 on the unit, then set the REC BIAS switch to NORMAL position.
3. Place the MONITOR switch in the TAPE position, LINE and OUTPUT controls to specified level position, put unit in the RECORD mode.
4. Adjust VR-303/306 for -8 dB signal at OUTPUT jacks.

OVERALL FREQUENCY RESPONSE

NORMAL position

1. Thread a blank SCOTCH 150 tape on the unit, place REC BIAS switch at NORMAL, TAPE SPEED at LOW, MONITOR switch at TAPE position.
2. Apply a signal swept from 30 Hz to 20 kHz at -23 dB to LINE IN jacks and record it on the tape.
3. While the unit in the RECORD mode, adjust L-301/303 for best response.

HIGH position

4. Thread a blank SCOTCH 203 tape on the unit. Place REC BIAS switch at NORMAL position, TAPE SPEED switch at HIGH.
5. Apply a signal swept from 30 Hz to 20 kHz at -23 dB to LINE IN jacks.
6. Repeat overall response check at both speeds.

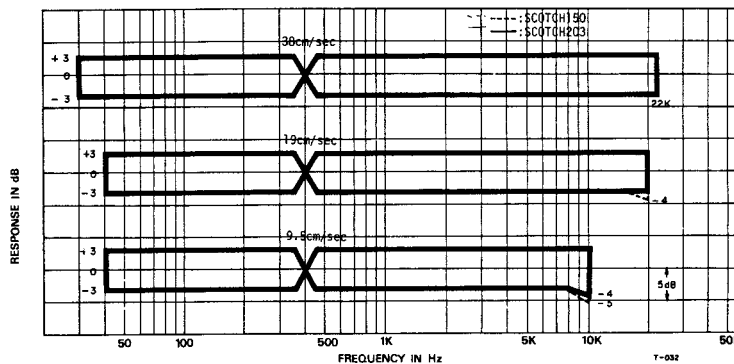

Fig. 11-6 Frequency Response Limits.

MONOPHONIC RECORDING

L-401 (DUMMY) Coil ... This must be checked on monophonic recording as in the following procedures:

1. Place the Record Mode switch L (or R, not both) to "ON" and R (or L) to the "OFF" position.
2. Record the signals swept from approx. 40 Hz to 20 kHz at -23 dB.
3. If necessary, adjust L-401 for best response.

SIGNAL-TO-NOISE RATIO

PLAYBACK

IMPORTANT

OUTPUT controls should be at the Specified Output Level settings. The signal-to-noise ratio must meet factory standards. The values given are obtained using an unweighted test set (M-826A) while the supply and take-up motors have voltage applied but are not rotating. The values are with reference to a 3% THD peak recording level.

1. Thread a blank SCOTCH 203 tape on the unit leaving the tape outside the capstan and pinch roller.
2. Place the unit in the PLAY mode (▶) (the tape will not move using PAUSE).
3. The test set connected to the OUTPUT jacks should indicate -56 dB or less.
4. This corresponds to a signal-to-noise ratio of 48 dB (difference between residual noise -56 dB and specified output level -8 dB for 1% THD).
For a 3% THD signal-to-noise ratio, -6 dB is added, giving 54 dB (3% THD is 6 dB above 1% THD level).

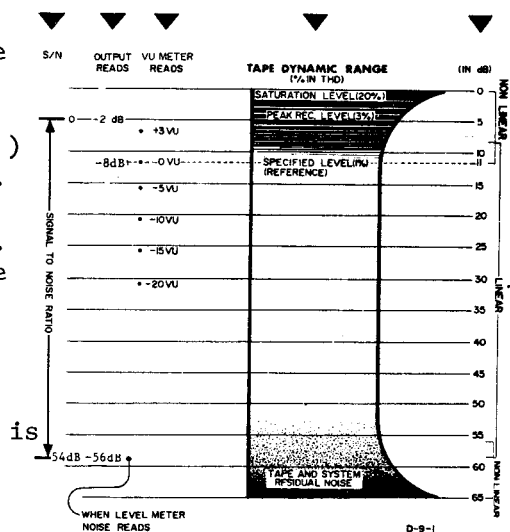

Fig. 11-7 Signal/Noise Computation

OVERALL

IMPORTANT: Clean and demagnetize the heads before proceeding. It is extremely important that all tests described in the preceding paragraphs have been completed and that all controls are left at their specified settings.

1. Thread a blank test tape SCOTCH 203 on the unit.
2. Remove the AF oscillator from the LINE IN jacks.
3. Place the unit in the RECORD mode with "no signal" applied. Note the point on the index counter where recording begins.
4. Rewind the tape to the beginning point and play it back.
5. The noise level as indicated on the test set should be -54 dB or less.

NOTE: Bias, erase and playback amplifier noise are all included in this measurement. All frequencies between 40 Hz and 15 kHz are measured unweighted.

ERASE EFFICIENCY

NOTE: To measure erase efficiency, a 1 kHz Band Pass Filter (TEAC M-204 CL filter) must be used.

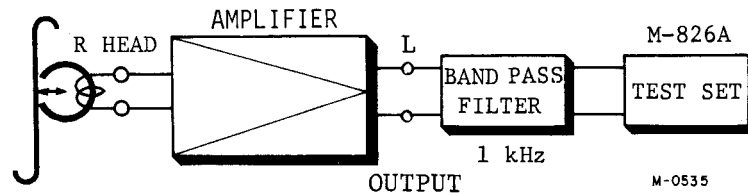

Fig. 11-8 Erase Efficiency Check Set-Up

1. Apply a 1 kHz signal at 0 dB to the LINE IN jacks.
2. Place the unit in RECORD mode and record this signal.
3. Rewind the recording to the beginning and remove the AF oscillator from the LINE IN jacks.
4. Connect a test set to the OUTPUT jack through the 1 kHz Band Pass Filter, select TAPE monitor.
5. Place the unit in RECORD mode and "record" (erase) over this portion of tape. Monitor the tape output on the test set.
6. The test set should indicate -65 dB (2T), -68 dB (4T) or less.

LEVEL VARIATION

1. Thread a blank reel of high output tape SCOTCH 203, and select 7-1/2ips (19 cm/s).
2. Record a variety of frequencies, such as 400 Hz, 2 kHz, 5 kHz, 8 kHz, 10 kHz, etc., at the specified input setting with the RECORD BIAS switch in HIGH position. Record approximately 10 seconds at each frequency.
3. During playback at 7-1/2ips the output level should not vary more than 0.5 dB at 400 Hz, 1 dB at 5 kHz to 10 kHz. With the unit at 3-3/4ips, the tolerances are the same as at 7-1/2ips.

12. SERVICING AND MAINTENANCE

1. Power supply

Make sure that the power supply is stable at the rated voltage. Fluctuations will result in uneven tape speed, and wow and flutter in the recorded signal.

2. Cleaning the heads

TEAC TZ-261A for Head cleaning, TZ-261B for Rubber cleaning must be used.

3. Lubrication

Lubrication should not be required unless a part has been replaced. First wipe off old oil, grease and dirt. Apply 1 or 2 drops of TEAC TZ-255 oil to all plastic tube for motors and pinch roller shaft. Grease other moving parts lightly with DAW DC33L or MOLYCOAT.

NOTE: If the motor pulley, capstan belt, flywheel and pinch roller become soiled with oil or grease, slippage will occur. Remove all traces of oil with TZ-261 A/B.

4. Demagnetization of the head

If the record or playback head become magnetized, noise will increase and fidelity will deteriorate. For this reason it is advisable to use non-magnetic tools when working near the head. In cleaning, tweezers of brass or other such non-magnetic and relatively soft material are preferred. Similarly, the use of a tester or vacuum tube ohm-meter should be avoided in connection with the head, as these instruments operate by applying a DC current, and will thus induce magnetism. If the heads have had any contact with currents or metal parts, demagnetize them with a TEAC E-1.

TEAC MAINTENANCE FLUIDS



TEAC TZ-261
Cleaner

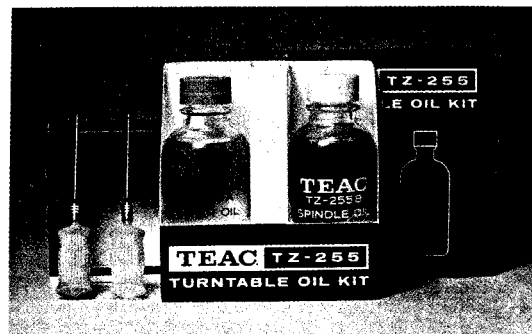

TEAC TZ-255
Oil Kit

13. PACKING FOR SHIPMENT

SHIPPING INSTRUCTIONS

If the unit is to be returned to a TEAC factory service Center for repair, carefully pack as shown below.

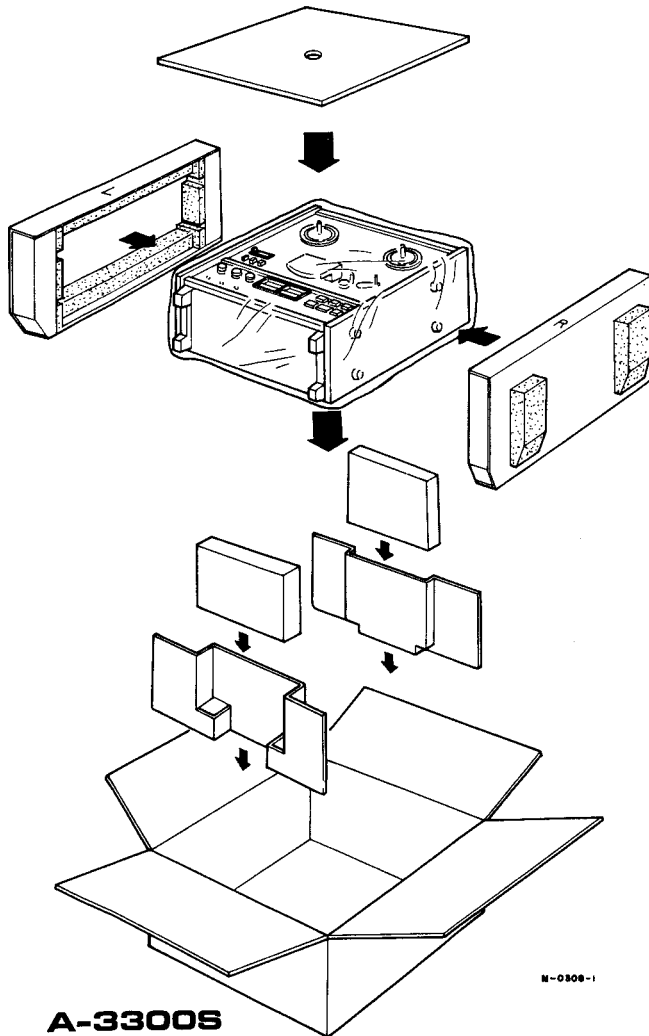

M-0300-1

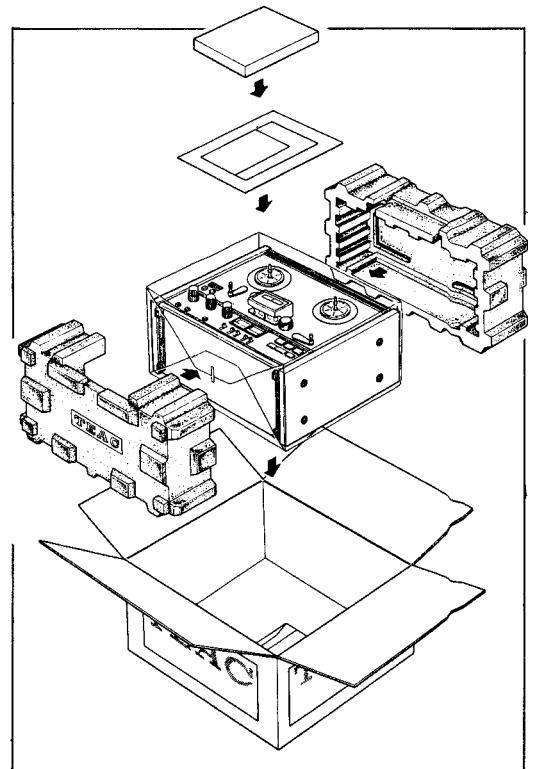

14. WARRANTY

Your TEAC equipment has been manufactured under the strictest quality control and is covered by warranty under normal operation. However, warranty terms may vary with the country (area) in which it was purchased and for different models of equipment. The warranty terms are fully described on the warranty card. Please read the card for complete details. Include a copy of the warranty in the package when you return the equipment to an Authorized Service Center.

15. TROUBLE SHOOTING

NOTE: The following guide lists specific difficulties that could occur in the A-3300S or A-2300S. Possible causes are listed for each malfunction. Visually inspect the unit for any damage such as broken or burned components or wiring, loose connections, etc.

MALFUNCTION	POSSIBLE SOURCE OF TROUBLE	CORRECTIVE PROCEDURE
Capstan fails to turn	Belt off or slipping, line fuse, safety switch(SW-2), speed select switch(SW-12), phase advance capacitor (C-5), rewind play relay (K-3)	Repair or replace the defective components.
Pinch roller fails to contact capstan in play mode	Operation relay(K-1), Start relay(K-7), rewind relay(K-3), STOP micro-switch(S-4), PLAY (▶) micro-switch(S-7), capstan solenoid	Refer to schematic diagram and repair or replace the defective components.
Right reel motor does not rotate in play mode. Left reel motor does not rotate in play mode. Both motors fail to operate.	Reel motor(right), brake solenoid, rewind relay(K-3), resistor(R-1) Reel motor(left), brake solenoid, rewind relay(K-3), resistor(R-2) Operating relay(K-1), start relay(K-7)	Replace the defective components.
Recorder does not operate in PLAY (▶)	Remote control jumper plug missing or loose, STOP micro switch(S-4), brake solenoid, resistor(R-3), rewind relay(K-3), phase advance capacitor(C-5)	Normal DC resistance of the brake solenoid is 1.3k ohms. Refer to schematic diagram and repair or replace the defective components.
Playback noise or hum	Faulty connections, head selector switch, faulty playback head, faulty amplifier	Repair or replace defective components.
Noise or hum during record	Magnetized head, faulty connections, MIC level set to maximum, faulty record amplifier, record relay (K-401)	Demagnetize and clean head, repair or replace defective components, check MIC VR.
Wow and flutter	Defective tape, dirty or defective pinch roller and pressure oily or defective belt, reel motor tension	Clean or replace defective components. Adjust motor tension
Incorrect tape speed	Drive belt in wrong position. Incorrect pinch roller pressure.	Reposition drive belt. Adjust pinch roller pressure.

MALFUNCTION	POSSIBLE SOURCE OF TROUBLE	CORRECTIVE PROCEDURE
Brakes do not release	Defective brake solenoid	The D.C resistance of the brake solenoid should be 1.6k ohms. Replace solenoid.
Fast forward or rewind mode inoperative	Rewind relay (K-3)	Refer to schematic diagram and repair or replace the defective components.
No record and/ or no erase	Record head dirty, erase head dirty, operate relay (K-1), record relay (K-401), REC micro switch (S-8), record amplifier, bias OSC, record head, erase head	Refer to schematic diagram and repair or replace the defective components.
No playback	Playback head defective or dirty, amplifier-to-deck connections, monitor switch (SW-501), playback amplifiers	Refer to playback amplifier voltage chart.

TEAC Oil Syringe →
-example-

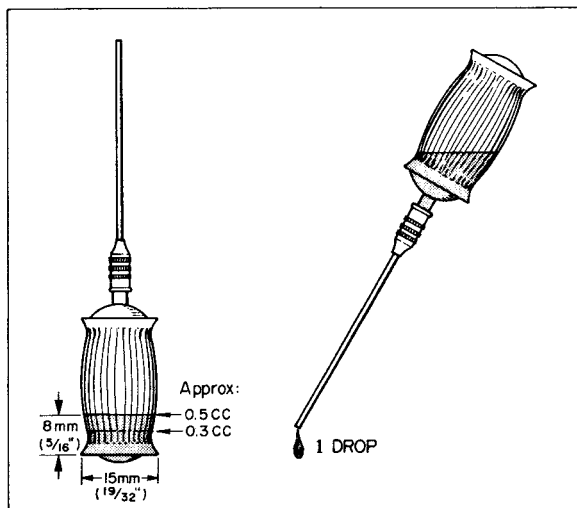

Reading for Color Code
-Resistor-

Reading for Color Code -Resistor-

Color	BLK	BRN	RED	ORG	YEL	GRN	BLU	VIO	GRY	WHT	GOL	SIL	Plain
BAND No.1	0	1	2	3	4	5	6	7	8	9			
No.2	0	1	2	3	4	5	6	7	8	9			
No.3	10 ⁰	10 ¹	10 ²	10 ³	10 ⁴	10 ⁵	10 ⁶	10 ⁷	10 ⁸	10 ⁹	10 ⁻¹	10 ⁻²	
No.4	(Tolerance)										5%	10%	20%

Example: No.1 BRN 1
 No.2 BLK 0
 No.3 GRN 10
 No.4 GOL ±5% Follow: Reading 1MΩ ±5%

TEAC®

A-2300S
A-3300S
STEREO TAPE DECKS
PARTS LIST

FIRST REVISED EDITION

REPLACEMENT INFORMATION

Replacement parts are available through your nearest TEAC Authorized Service Center or directly from the TEAC office.

Changes are constantly being made to make TEAC products better and more reliable. Therefore, when ordering parts, always include the following information:

<i>MODEL</i>	<i>SERIAL NO.</i>	<i>REF.NO.</i>	<i>PARTS NO.</i>	<i>DESCRIPTION</i>
--------------	-------------------	----------------	------------------	--------------------

PARTS IDENTIFICATION CODING

Parts are identical between the different models with the exceptions as coded by the designations explained below.

A-2300S For all markets, 2300S and A-2300S only, 4 track or 2T.
Written in italics.

A-3300S For all markets, 3300S and A-3300S only, 4 track or 2T.
Written in italics.

DM Only for domestic (Japan) market decks.

TCA For TEAC Corporation of America (US) decks.

4T For decks with the 4 track head configuration (standard).

2T For decks with the 2 track head configuration.
(These decks have 2T included in the nomenclature,
i.e., *A-2300S-2T*).

Effective : June, 1974
Latest Revision No.: E-670

TEAC CORPORATION

51030871

1. TRIM PARTS A-2300S

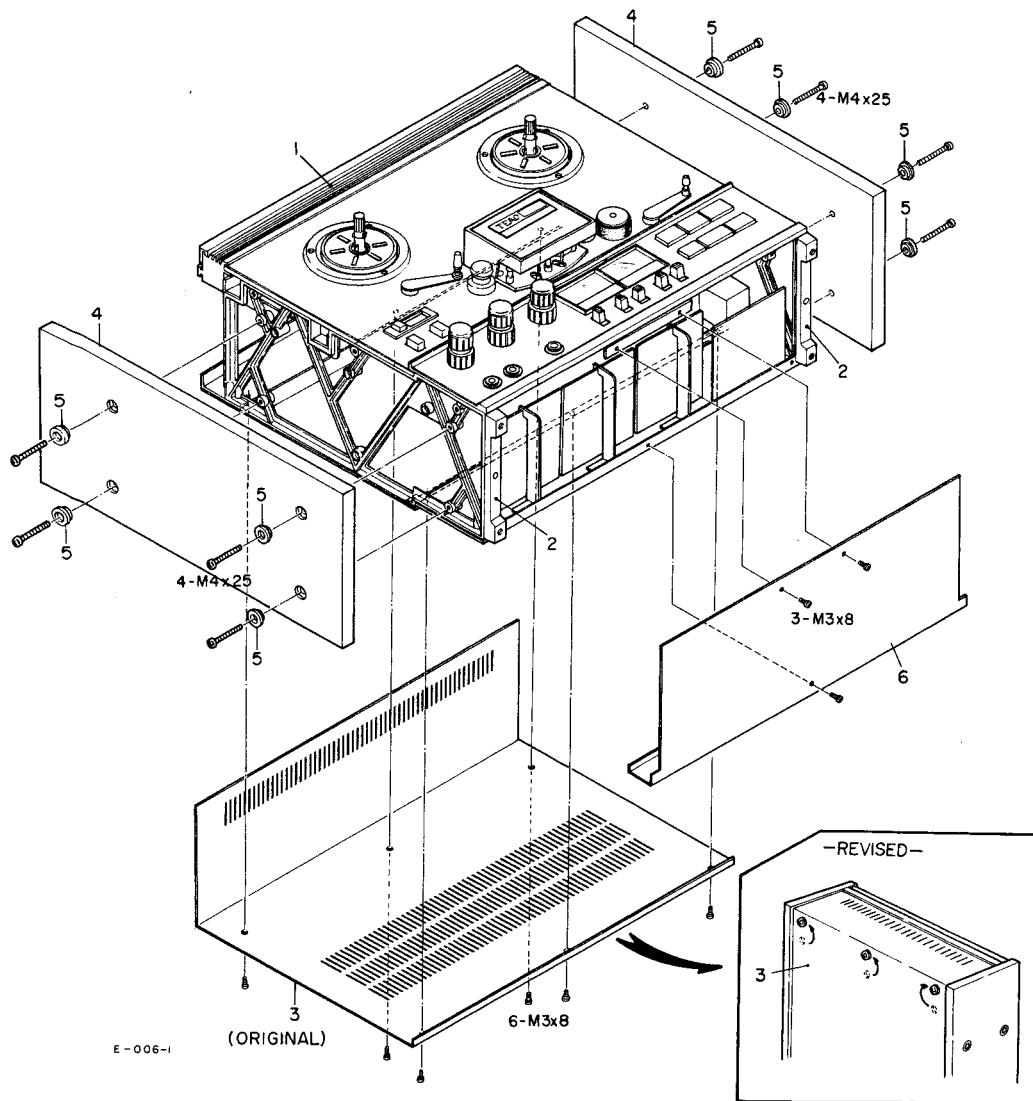

The location of the top cover mounting screws have been changed as indicated.

From SER. NO.19131 to Present

PARTS LIST-1

REF. ORIGINAL NO. PARTS NO. DESCRIPTION	REVISION
1-1 50112980 Grille Assy, Top	
1-2 50277980 Leg, Case	
1-3 50288291 Cover Assy, Rear	*50288292
1-4 50288331 Wooden Plate	
1-5 50276930 Washer, Trim	
1-6 50288641 Cover Assy, Bottom	**55003580

* Original and Later Rear Cover Assy are not interchangeable.

** Original and Later Bottom Cover Assy are interchangeable.

2. TRIM PARTS A-3300S

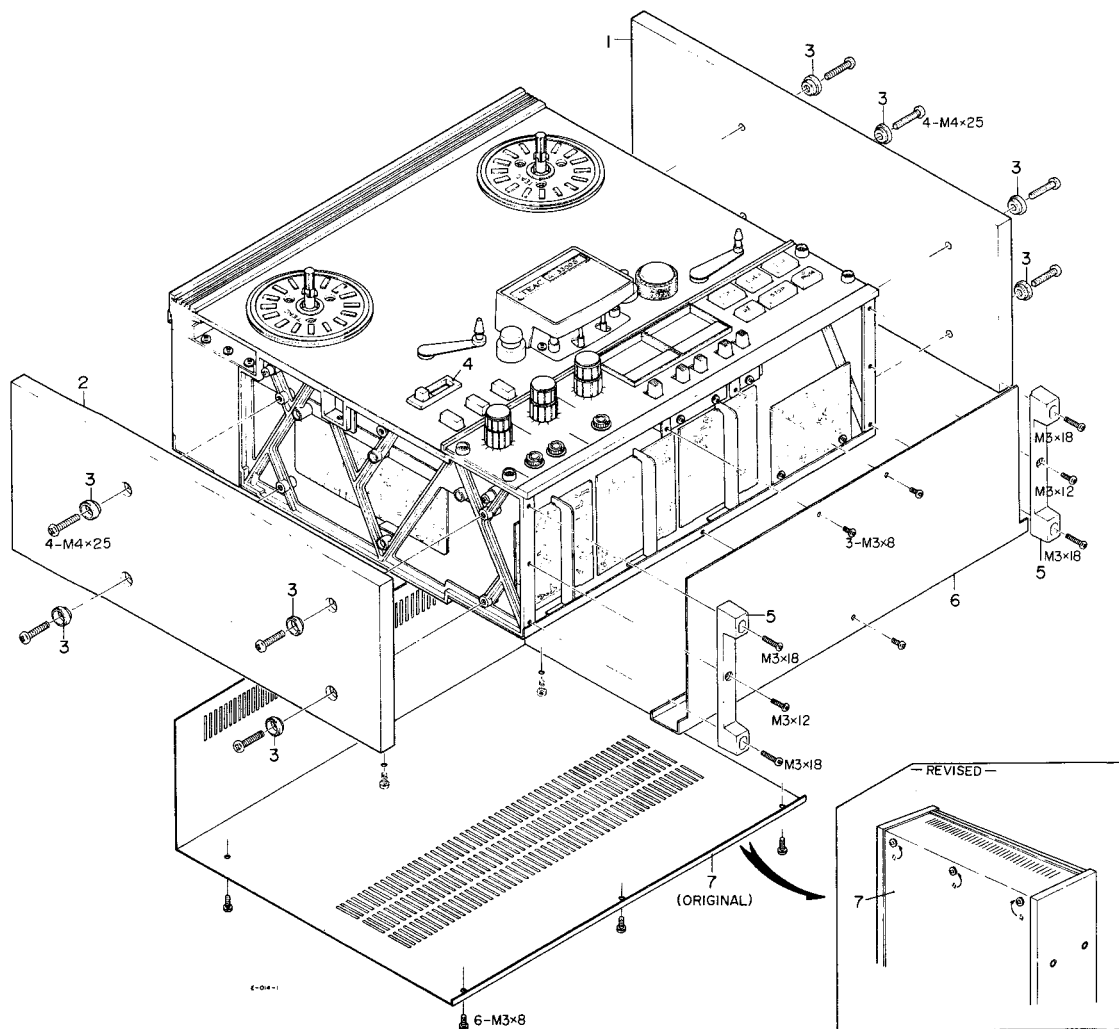

The location of the top cover mounting screws have been changed as indicated.

From SER. NO. to Present

PARTS LIST-2

REF. ORIGINAL NO. PARTS NO. DESCRIPTION	REVISION
2-1 50288011 Wooden Plate, A	
2-2 50288021 Wooden Plate, B	
2-3 50276930 Washer, Trim	
2-4 50162980 Cover, Counter	
2-5 50277980 Leg, Case	
2-6 50288641 Cover Assy, Bottom	*55003580
2-7 50288301 Cover Assy, Rear	**50288302

* Original and Later Bottom Cover Assy are interchangeable.

** Original and Later Rear Cover Assy are not interchangeable.

3. CONTROL PANEL

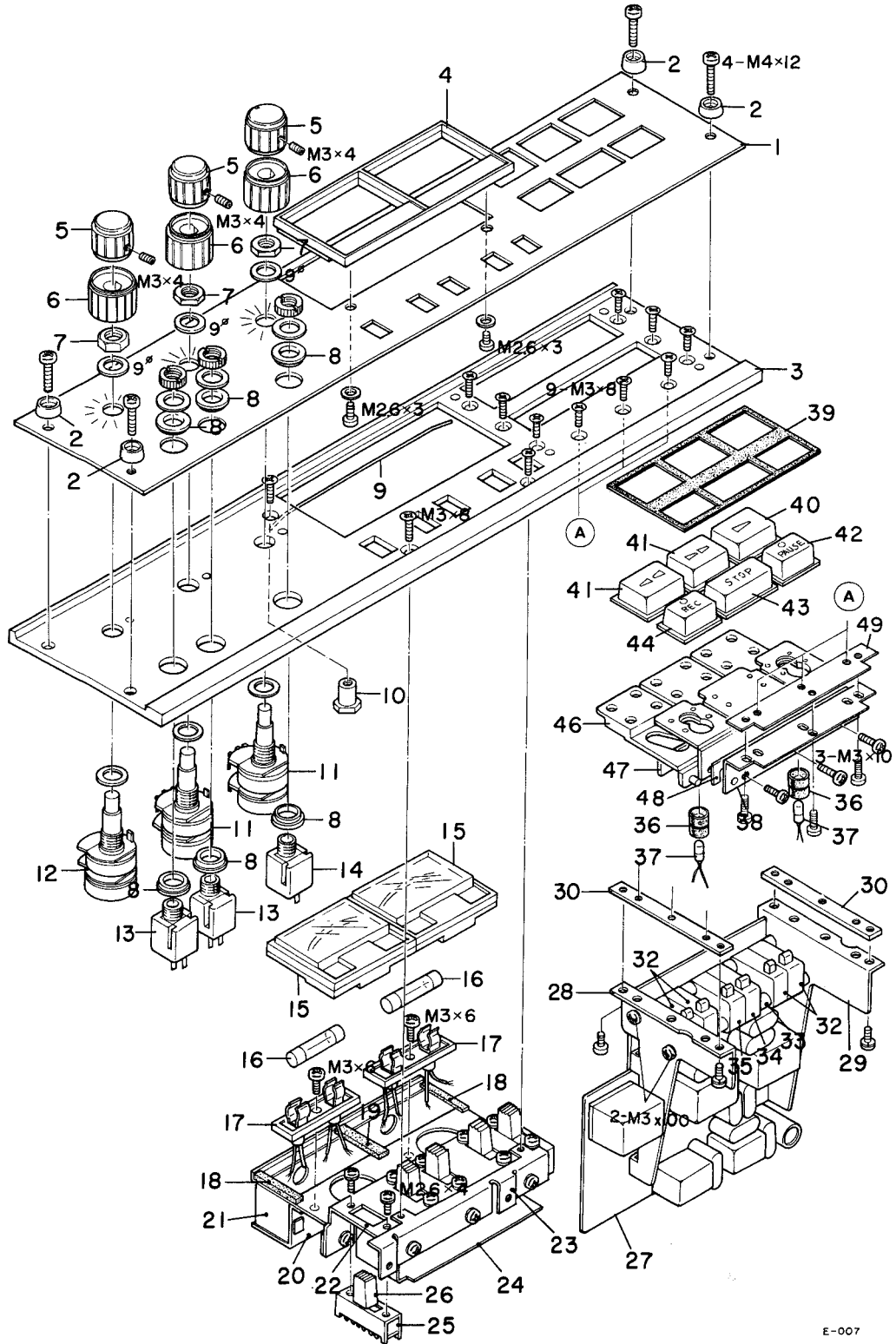

PARTS LIST-3

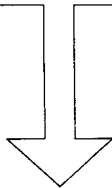
REF. NO.	ORIGINAL PARTS NO.	DESCRIPTION	REVISION
3- 1	50237091	Panel, Ampl. Trim	<div style="border: 1px solid black; padding: 10px; margin-bottom: 10px;"> <p>*Original and Later parts are not interchangeable.</p> <p>**Original and Later parts are interchangeable.</p> </div> <div style="text-align: center; margin-bottom: 10px;">  </div> <p>*51680650 (From SER. No. 9681)</p> <p>**55505200</p> <p>Removed **55505210</p>
3- 2	50277111	Washer, Trim	
3- 3	50237112	Panel, Ampl.	
3- 4	50279830	Escutcheon, VU Meter	
3- 5	50237370	Knob, Upper (4T)	
	50253390	" , " (2T)	
3- 6	50237382	Knob, Lower (4T)	
	50253401	" , " (2T)	
3- 7	50276920	Lock Nut	
3- 8	50332650	Washer, Insul.	
3- 9	50331630	Clamp, Meter Escutcheon	
3-10	50331430	Shaft, Ampl. Panel	
3-11	50537090	VR, 2 Gang, 100kΩ × 2	
3-12	50537100	VR, 2 Gang, 10kΩ × 2	
3-13	50430240	Jack, Phone; Single (MIC)	
3-14	50432450	Jack, Phone; 3 cond. (PHONES)	
3-15	50581331	VU Meter	
3-16	50414640	Tubular Lamp	
3-17	50412340	Fuse Holder	
3-18	50236130	Cushion Plate, Meter; B	
3-19	50236120	Cushion Plate, Meter; A	
3-20	50237320	Meter Retainer Assy; P	
3-21	50237350	Cover, Lamp	
3-22	50237310	Place, Slide SW; P	
3-23	50236730	Angle, Bottom Plate	
3-24	50237361	Shield Plate, SW	
3-25	50440000	SW, Slide	
3-26	50279991	Cap, Slide SW	
3-27	50490890	PC Bd. Assy, Control Relay-2 (A-3300S)	
	50491020	" , " (A-2300S)	
3-28	50237131	Plate, SW; Left	
3-29	50237141	Plate, SW; Right	
3-30	50237121	Plate	
3-31		(not used)	
3-32	50446580	SW, Micro; VV-15-3A	
3-33	50237160	Spacer	
3-34	50446570	SW, Micro; VV-15-2A	
3-35	50446560	SW, Micro; VV-15-1A	
3-36	50237490	Cushion, Lamp	
3-37	50414630	Lamp	
3-38	50332760	Bracket, Hinge	
3-39	50237300	Rubber Protector, P	
3-40	50237201	Pushbutton, A (▶)	
3-41	50237211	Pushbutton, B (▶ ▶)	
3-42	50237262	Button, Pause	
3-43	50237221	Pushbutton, Stop	
3-44	50237233	Pushbutton Assy, Record	
3-45	50237170	Hinge, A	
3-46	50237182	Hinge, B	
3-47	50237291	Plate Nut, PC Board	
3-48	50332720	Plate, Hinge Adjusting	
3-49	50332750	Plate Nut, Hinge	

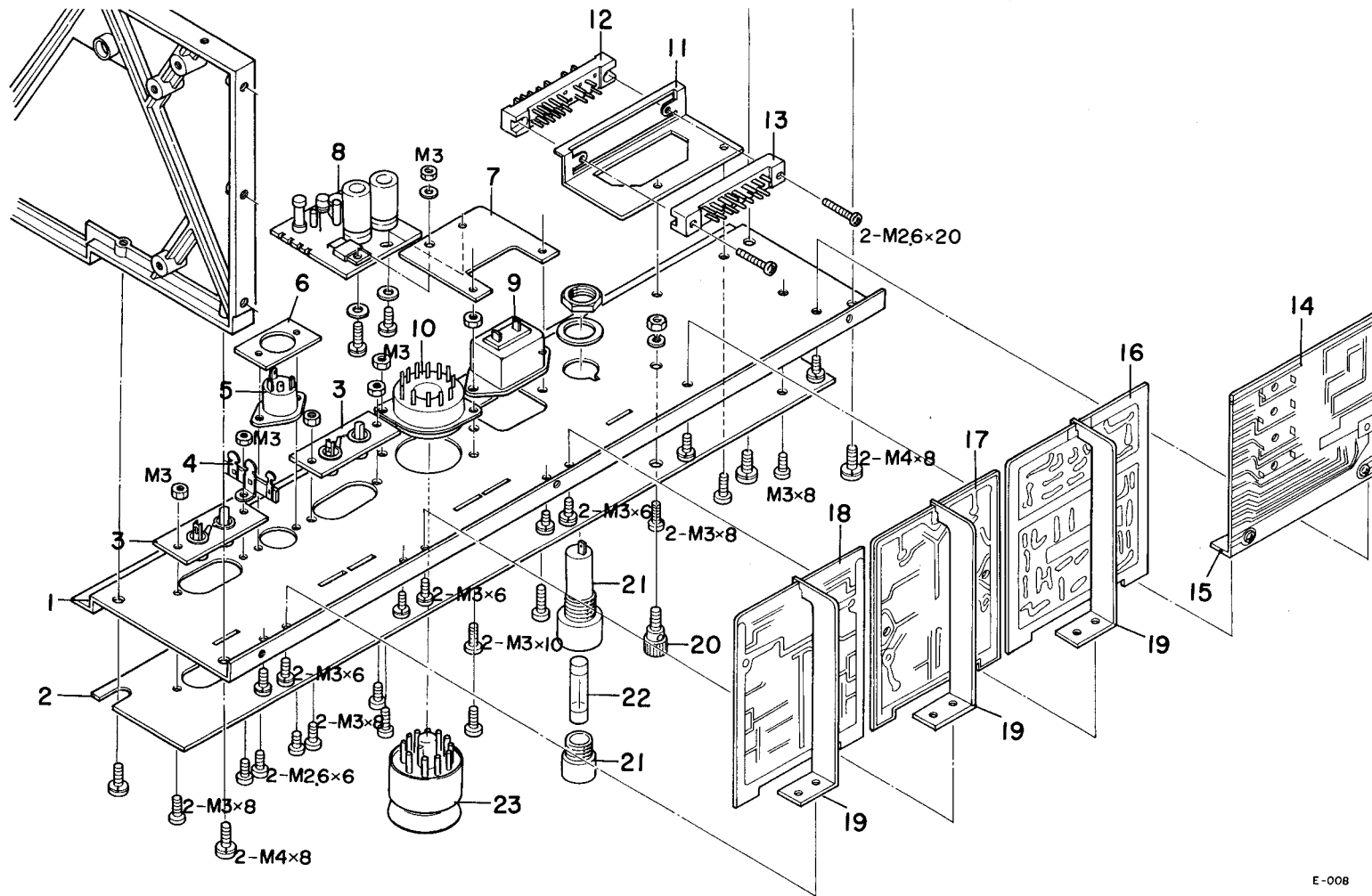

4. REAR PANEL

PARTS LIST-4

REF. NO.	ORIGINAL PARTS NO. DESCRIPTION	REVISION		APPLICABILITY	
		1st	2nd		
4- 1	50237400	Chassis, Ampl.			
4- 2	50237410	Panel, Rear Trim			
4- 3	50434631	Jack, Pin; 2P			
4- 4	50452060	Terminal Strip, 1L-2P			
4- 5	50430010	Connector, DIN			
4- 6	50233530	Plate, DIN Connector			
4- 7	50237020	Plate, PC Board Holder			
4- 8	50491050	PC Bd. Assy, Voltage Regulator			
4- 9	50432950	Socket, AC			
4-10	50432350	Socket, 11P			
4-11	50237450	Bracket, Connector			
4-12	50436530	Connector, 15P (Plug)(DM)			
	50436520	" , " (")(TCA)			
4-13	50438310	Connector, 15P (Socket)(DM)			
	50438300	" , " (")(TCA)			
4-14	50490870	PC Bd. Assy, Bias Oscillator			
4-15	50332550	Angle, PC Board; Left			
4-16	50491184	PC Bd. Assy, Meter/Rec. EQ Ampl.	50491185	50491186	A-2300S-4T
	50490864	" , "	50490865	50490866	A-3300S-4T
	50491275	" , "	50491276	—————>	A-2300S-2T
	50490964	" , "	50490965	—————>	A-3300S-2T
4-17	50491260	PC Bd. Assy, Line Out/Phone Ampl.			A-2300S-4T
	50490850	" , "			A-3300S-4T
	50491170	" , "			A-2300S-2T
	50490980	" , "			A-3300S-2T
4-18	50491162	PC Bd. Assy, Mic./Playback EQ Ampl.	—————>	50491163	A-2300S-4T
	50490841	" , "	—————>	50490842	A-3300S-4T
	50491250	" , "	50191251	—————>	A-2300S-2T
	50490970	" , "	50490971	—————>	A-3300S-2T
4-19	50233760	Plate, PC Board			
4-20	50454071	Post, Grounding			
4-21	50924500	Fuse Holder (DM)			
	50412280	" (TCA)			
4-22	50411140	Fuse, 2A			
4-23	50432511	Dummy Plug			

NOTE: The revised PC Board assemblies indicated above were changed concurrent with the new heads incorporated from the Serial numbers given below. For further information about these changes, see page 8, HEAD ASSEMBLY, and the orange-colored SERVICE MANUAL REVISION NOTICE at the rear of this PARTS LIST.

APPLICABLE SERIAL NUMBERS

REVISION MODEL	1st	2nd
A-2300S-4T	#9681~	#14881~Present
A-3300S-4T	#8181~	#11881~Present
A-2300S-2T	#15581~Present	
A-3300S-2T	#12381~Present	

5. HEAD ASSEMBLY

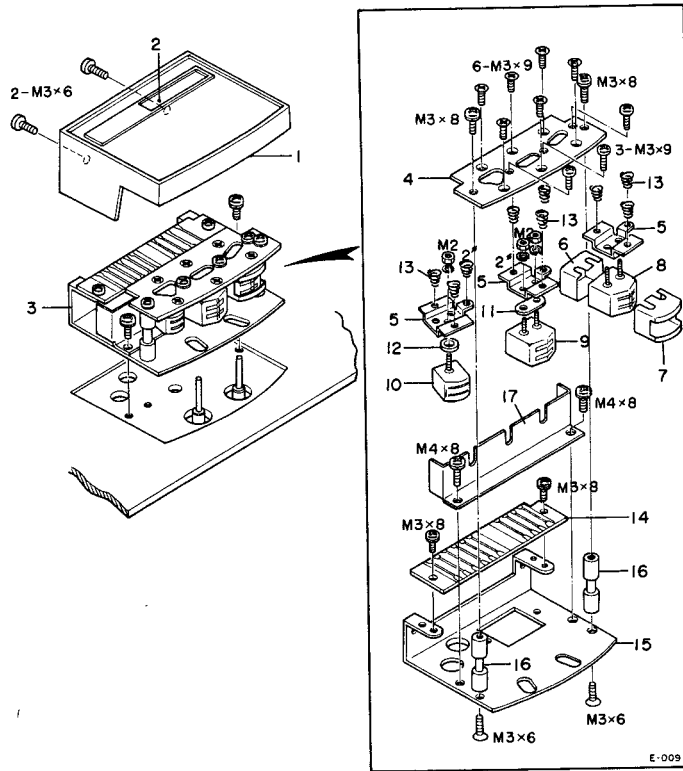

PARTS LIST-5

REF. NO.	ORIGINAL PARTS NO. DESCRIPTION	REVISION		APPLICABILITY
		1st	2nd	
5- 1	50136550 Head Housing			
5- 2	50136721 Name Plate [A-2300S] (DM)			
	50136811 " [2300S] (TCA)			
	50136701 " [A-3300S] (DM)			
	50136711 " [3300S] (TCA)			
5- 3	55900140 Head Assy (4T)	→ ①	55900142	→ 4T
	55900150 " (2T)	→ ②	55900152	→ A-2300S-2T
		→ ②	55902630	→ A-3300S-2T
5- 4	50134400 Plate, Head Base			
5- 5	50134371 Plate, Head			
5- 6	50133901 Head Shield, B	① ②	Removed	→ All
5- 7	50133891 Head Shield, A	①	Removed	→ 4T
		→ ②	50679870	→ ④ Removed A-2300S-2T
				→ ⑤ 50136790 A-3300S-2T
5- 8	50669040 Head, PB (4T)	→ ①	50664490	↔ ③ 50663240 4T
	50668050 " , " (2T)	→ ②	50662250	→ A-2300S-2T
		→ ②	50662220	→ A-3300S-2T
5- 9	50666041 Head, Record (4T)	→ ①	50664480	↔ ③ 50663140 4T
	50665041 " , " (2T)	→ ②	50662150	→ A-2300S-2T
		→ ②	50662120	→ A-3300S-2T
5-10	50663030 Head, Erase (4T)			
	50662030 " , " (2T)			
5-11	50134390 Spacer, Head	→	↔ ③ ④ ⑤ 55501511	All
5-12	50136540 Spacer, Erase Head			
5-13	50220500 Spring, Head, B			
5-14	50484210 PC Board, Head			
5-15	50136560 Plate, Housing Base; C			
5-16	50182672 Pin, Guide			
5-17	50136690 Bracket, Head Protector			
5-18	(not used) Spacer, Head	① ②	50134390	↔ ③ ④ 55501511 All exc. A-3300S-2T
			(added)	→ ⑤ 50136800 A-3300S-2T

HEAD REVISIONS-ILLUSTRATED

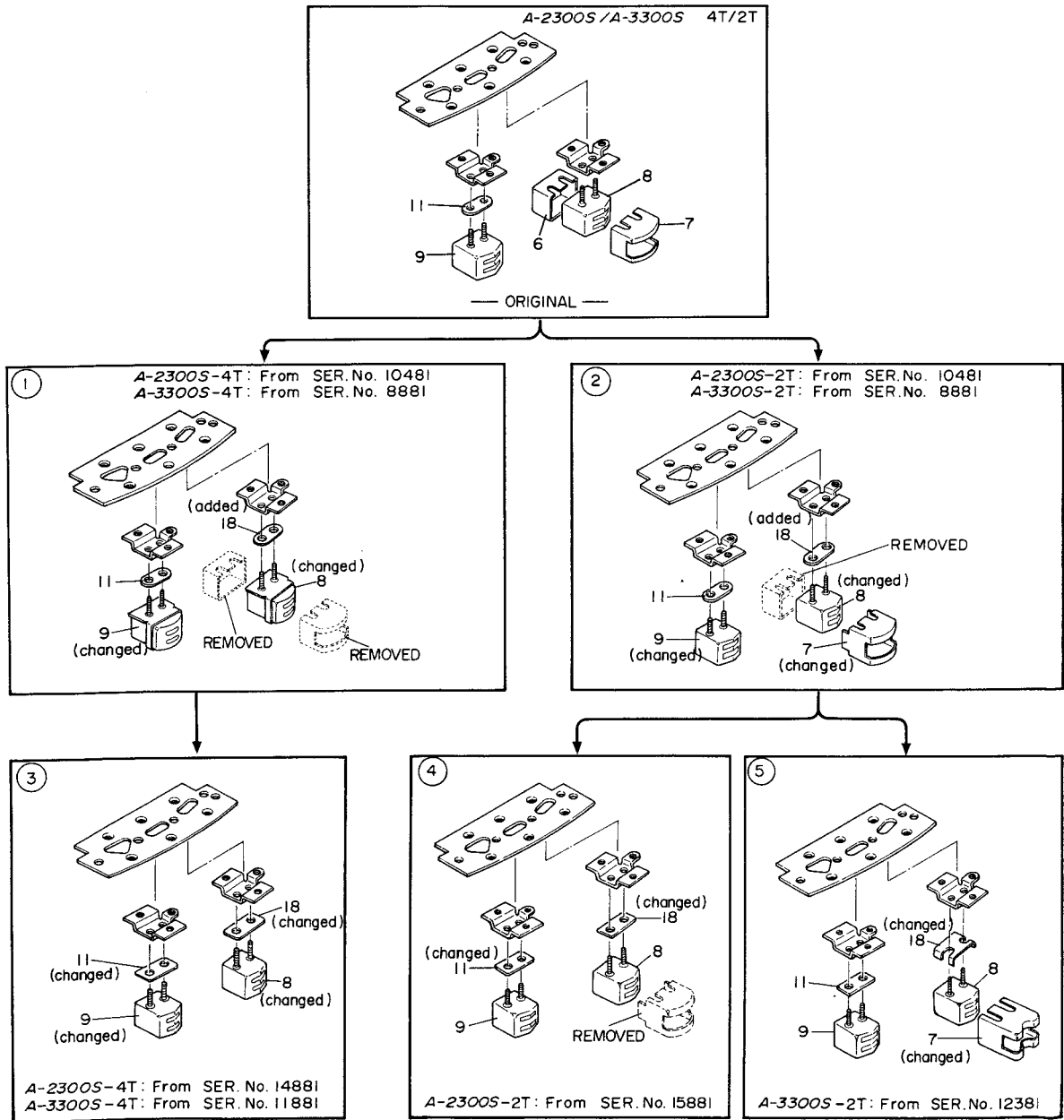

E-10

NOTE: 1. ∇ Indicates that there is no interchangeability. Use the Later number only with the applicable serial numbers. Former units require Former parts; Later units Later parts.

\leftrightarrow Indicates 100% compatibility or interchangeability between these two numbers.

2. In the parts listing, the circled numbers (⑨) correspond to the number of the Partial View above.
3. Accompanying the revision in heads, some electronic components (and alignment procedures) have been changed. For details, see the orange-colored SERVICE MANUAL REVISION NOTICE included at the back of this PARTS LIST.

6. TRANSPORT CHASSIS A-2300S

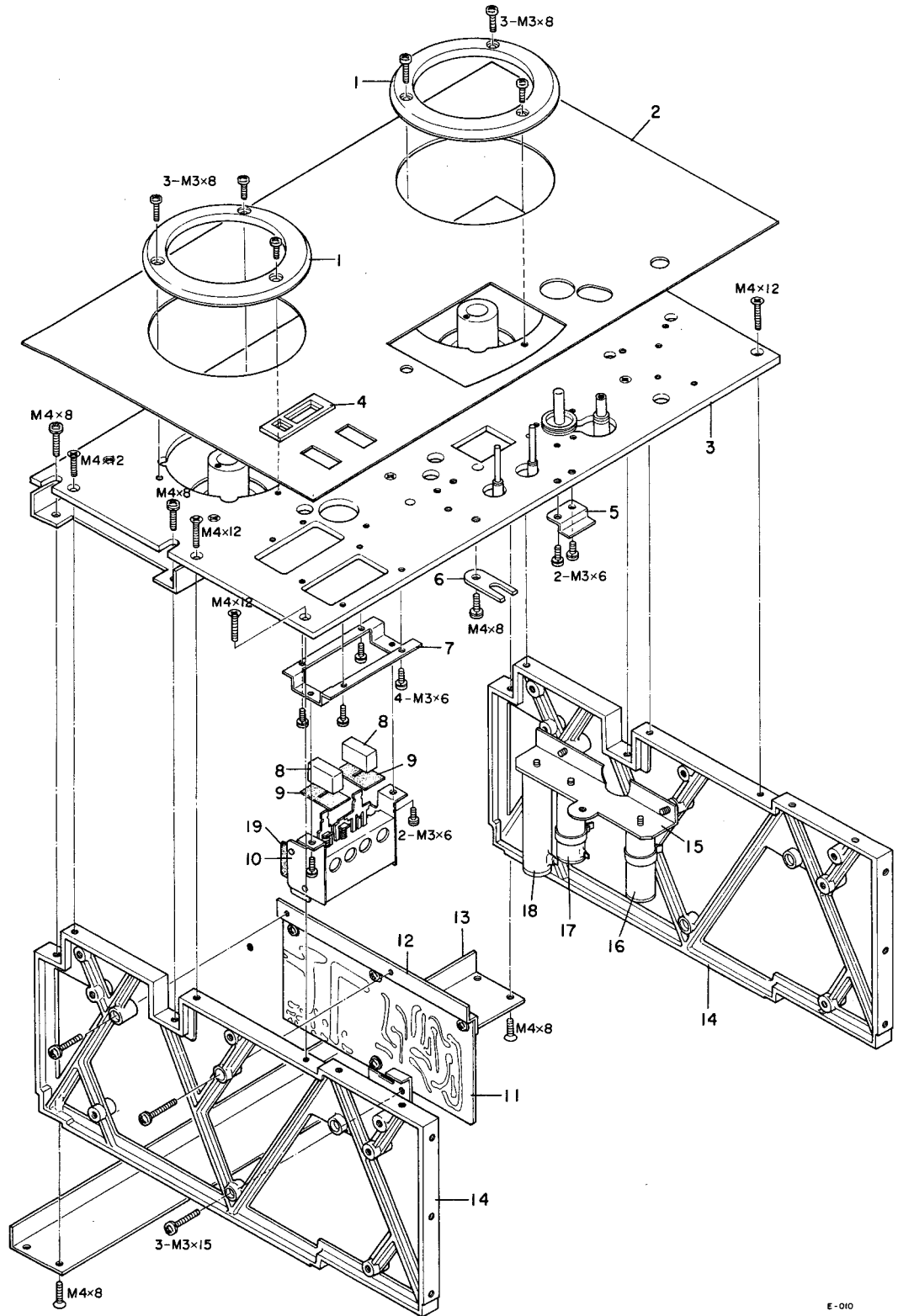

PARTS LIST-6

REF. NO.	ORIGINAL PARTS NO.	DESCRIPTION	REVISION
6- 1	50161940	Reel Protector	
6- 2	50114250	Panel, Trim	
6- 3	50114272	Panel, Chassis	50114273
6- 4	50162980	Cover, Counter	
6- 5	50237070	Plate, VU Meter Support	
6- 6	50331440	Plate, Chassis Panel	
6- 7	50237470	Plate, Selector SW	
6- 8	50253890	Knob, SW	
6- 9	50253880	Mask, SW	
6-10	50443901	Selector SW	
6-11	50491031	PC Bd. Assy, Power Supply	
6-12	50332540	Angle, PC Board	
6-13	50235312	Angle, Rear Cover	
6-14	50112713	Frame, Side	
6-15	50330110	Plate, Resistor	
6-16	50522330	R, Wire Wound; 400 Ω 20HA (R2)	700 Ω (50522370)
6-17	50524201	R, Wire Wound; 100 Ω 20HA (R1)	
6-18	50522340	R, Wire Wound 450 Ω 30H (R4)	1.2k Ω (50522380)
6-19	50332670	Plate, Insul.; Micro SW	

- NOTE: 1. Wire Wound Resistors have been changed with the change in Reel Motors from SER. No. 2891. See page 17 in this Parts List.
2. The Chassis Panel has been modified to accept the revised Pinch Roller Arm assembly. See page 23.

PARTS LIST-7

REF. NO.	ORIGINAL PARTS NO.	DESCRIPTION	REVISION
7- 1	50113410	Side-Panel, Left	
7- 2	50113420	Side-Panel, Right	
7- 3	50235311	Angle, Rear Cover	
7- 4	50112713	Frame, Side	
7- 5	50241850	Spacer, Wooden Plate	
7- 6	50490921	PC Bd. Assy, Power Supply	
7- 7	50332540	Angle, PC Board	
7- 8	50237060	Bracket, PC Board	
7- 9	50112980	Grille Assy, Top	
7-10	50443901	Selector SW	
7-11	50253880	Mask, SW, x2 (4T)	
	50253900	Mask, SW (2T)	
7-12	50253530	Knob, D	
7-13	50443870	SW, Push (POWER) (DM)	
	50444560	" , " (") (TCA)	
7-14	50237083	Plate, Push SW	
7-15	50237391	Plate, Selector SW	
7-16	50114210	Panel, Trim, A (4T)	
	50114220	" , " , B (2T)	
7-17	50114242	Panel, Chassis	50114243
7-18	50331440	Plate, Chassis Panel	
7-19	50237070	Plate, VU Meter Support	
7-20	50332670	Plate, Insul.; Micro SW	

NOTE: The Chassis Panel has been modified to accept the revised Pinch Roller Arm assembly. See page 23.

8. LEFT TENSION ARM

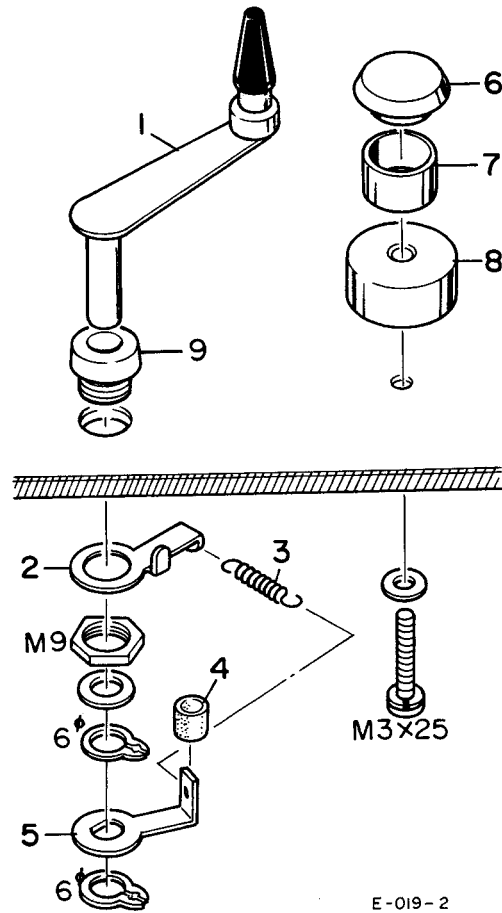

PARTS LIST-8

REF. ORIGINAL NO. PARTS NO. DESCRIPTION	REVISION
8-1 50180590 Tension Arm Assy, Left	
8-2 50276870 Anchor, Spring; Left	
8-3 50221110 Spring, B	
8-4 50276990 Collar, Rubber	
8-5 50182750 Travel Limiter, Tension Arm	
8-6 50123910 Cap, Guide Ring	
8-7 50123930 Ring, Guide	
8-8 50123921 Guide Ring Base	
8-9 50182701 Bushing, Arm; A	

9. RIGHT TENSION ARM

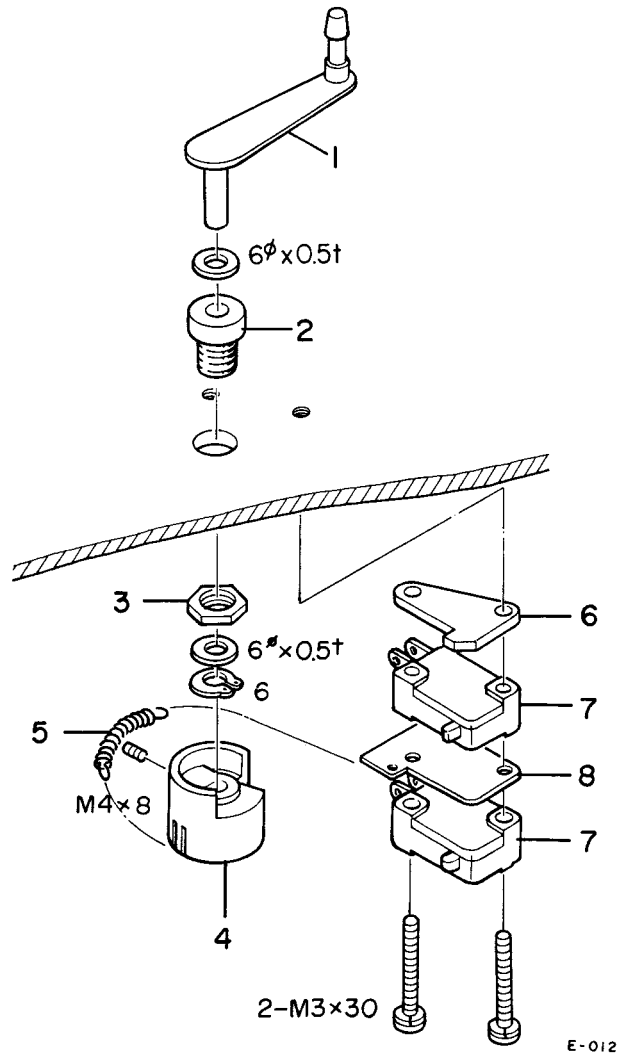

PARTS LIST-9

REF. NO.	ORIGINAL PARTS NO.	DESCRIPTION	REVISION
9-1	50180432	Tension Arm Assy, Right	
9-2	50182701	Bushing, Arm A	
9-3	50276920	Lock Nut	
9-4	50183920	Drum, Tension Arm	
9-5	50221122	Spring, Tension Arm; C	
9-6	50182730	Limit Stop, Right	
9-7	50446180	SW, Micro (V-1A44)	
9-8	50183931	Plate, Insul.	

10. REEL MOTOR ASSEMBLY

A-2300S

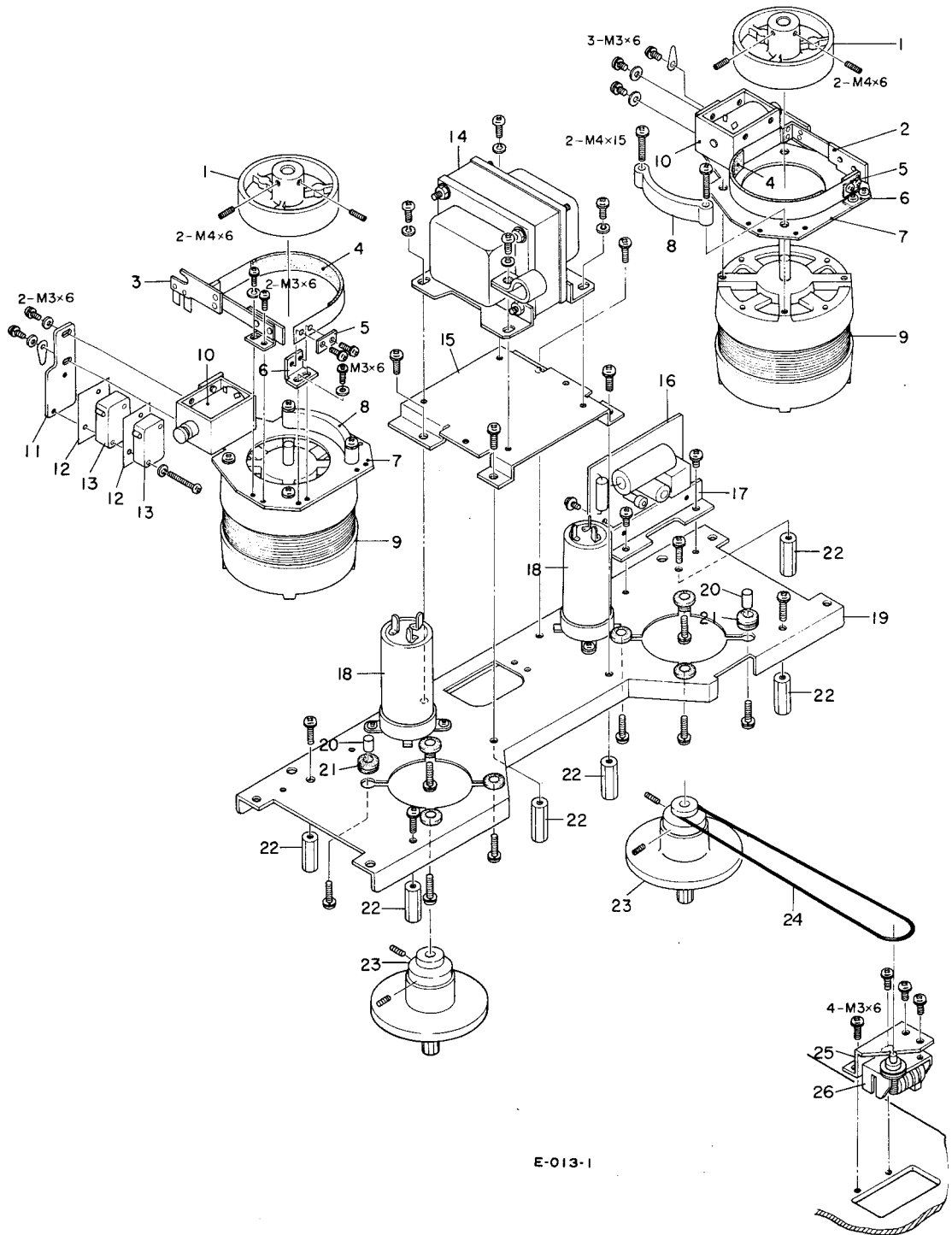

E-013-1

PARTS LIST-10

REF. NO.	ORIGINAL PARTS NO.	DESCRIPTION	REVISION
10- 1	50173560	Drum, Brake	
10- 2	50170182	Brake Band Assy, A	
10- 3	50173661	Brake Band Assy, C	
10- 4	50171382	Felt, Brake	
10- 5	50170150	Plate, Band Pressure	
10- 6	50170160	Angle, Band	
10- 7	50173650	Plate, Reel Motor	
10- 8	50172550	Brake Retainer	
10- 9	50702252	Motor, Reel	* 71041041
10-10	50616620	Solenoid, Brake	** 50616770
10-11	50173690	Bracket, Micro SW	
10-12	50332680	Insulator Plate, Micro SW	
10-13	50446180	SW, Micro; V-1A-44	
10-14	50562621	Transformer, Power	
10-15	50236650	Plate, Power Transformer	
10-16	50491190	PC Bd. Assy, Control Relay-1	
10-17	50332571	Angle, PC Board	
10-18	50545500	C, MP; (3+1) μ F 250V	*(3.9+0.9) μ F (50545940)
10-19	50237460	Chassis, Reel Motor, S	
10-20	50162760	Spacer, Rubber Cushion	
10-21	50162960	Cushion, Rubber, B	
10-22	50161950	Standoff, Reel Motor	
10-23	50160332	Reel Table Assy	
10-24	50332560	Belt, Counter	
10-25	50332520	Plate, Counter	
10-26	50585140	Counter	

- NOTE: 1. The Reel Table Assy (10-23) is assembled with very accurate adjustments performed during the assembly process. We no longer list the individual pieces because separate replacement of them would be meaningless. Therefore, we ask you to order the entire assembly for replacement.
2. *From Serial #2891, the Reel Motors have been changed to the revised part, which requires a different capacitor and resistors than the original. When replacing a Reel Motor for units numbered below 2891, it is suggested that the revised part be used and the capacitor and resistors be replaced as shown below. Always use the new motor for replacement in decks from Ser. #2891.

Description	Original	Present	Remarks
Motor, Reel (10-9)	50702252	71041041	
Capacitor, MP (10-18)	(3+1) μ F 250V (50545500)	(3.9+0.9) μ F 250V (50545940)	
R, Wire Wound (6-16, R2)	400 Ω 20HA (50522330)	700 Ω 20HA (50522370)	See pg. 11
R, Wire Wound (6-18, R4)	450 Ω 30H (50522340)	1.2k Ω 30H (50522380)	See pg. 11'

From SER.NO. 2891 to Present

3. **Original and Later Solenoid are interchangeable.

11. REEL MOTOR ASSEMBLY

A-3300S

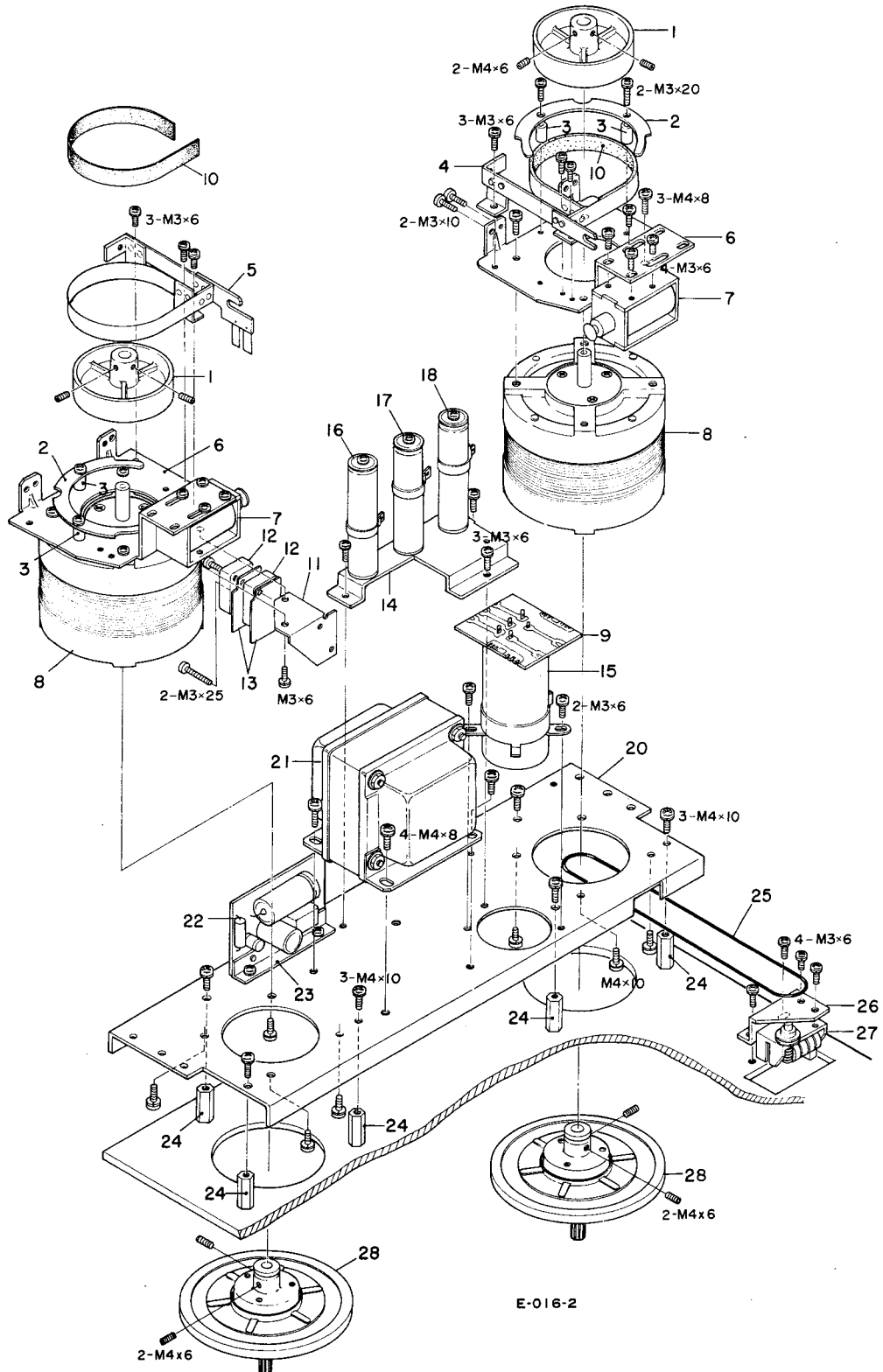

PARTS LIST-11

REF. NO.	ORIGINAL PARTS NO.	DESCRIPTION	REVISION
11- 1	50173570	Drum, Brake	
11- 2	50173481	Brake Retainer	
11- 3	50173490	Spacer, Brake Retainer	
11- 4	50173331	Brake Band Assy, L	
11- 5	50173610	Brake Band Assy, P	
11- 6	50173600	Plate, Reel Motor, P	
11- 7	50616620	Solenoid, Brake	
11- 8	[50702320]*	Motor, Reel	70702322
11- 9	50484191	PC Bd., MP Capacitor	
11-10	50173410	Felt, Brake	
11-11	50173640	Plate, Micro SW	
11-12	50446180	SW, Micro; V-1A44	
11-13	50332680	Plate, Insul.; Micro SW	
11-14	50235560	Plate, Resistor	55540840
11-15	50545820	C, MP (5.3+0.7) μ F x2 250V	
11-16	50522230	R, Wire Wound (100 Ω 30HA)(R1)	
11-17	50522250	R, Wire Wound (150 Ω 30HA)(R3)	250 Ω 30HA (50522280)
11-18	50522280	R, Wire Wound (250 Ω 30HA)(R2)	
11-19		(not used)	
11-20	50236803	Chassis, Reel Motor; B	
11-21	50562561	Transformer, Power	
11-22	50490912	PC Bd. Assy, Control Relay-1	
11-23	50233930	Angle, PC Board; B	50332571
11-24	50161950	Standoff, Reel Motor	
11-25	50332530	Belt, Counter, P	
11-26	50332520	Plate, Counter	
11-27	50585140	Counter	
11-28	50160314	Reel Table Assy	

- NOTE:
1. The Reel Table Assy (11-28) is assembled with very accurate adjustments performed during the assembly process. we no longer list the individual pieces because separate replacement of them would be meaningless. Therefore, we ask you to order the entire assembly for replacement.
 2. All revised parts are interchangeable between Original and Later types.
 3. *Typographical error in Original Parts List. Do not order this number.

12. CAPSTAN DRIVE ASSEMBLY

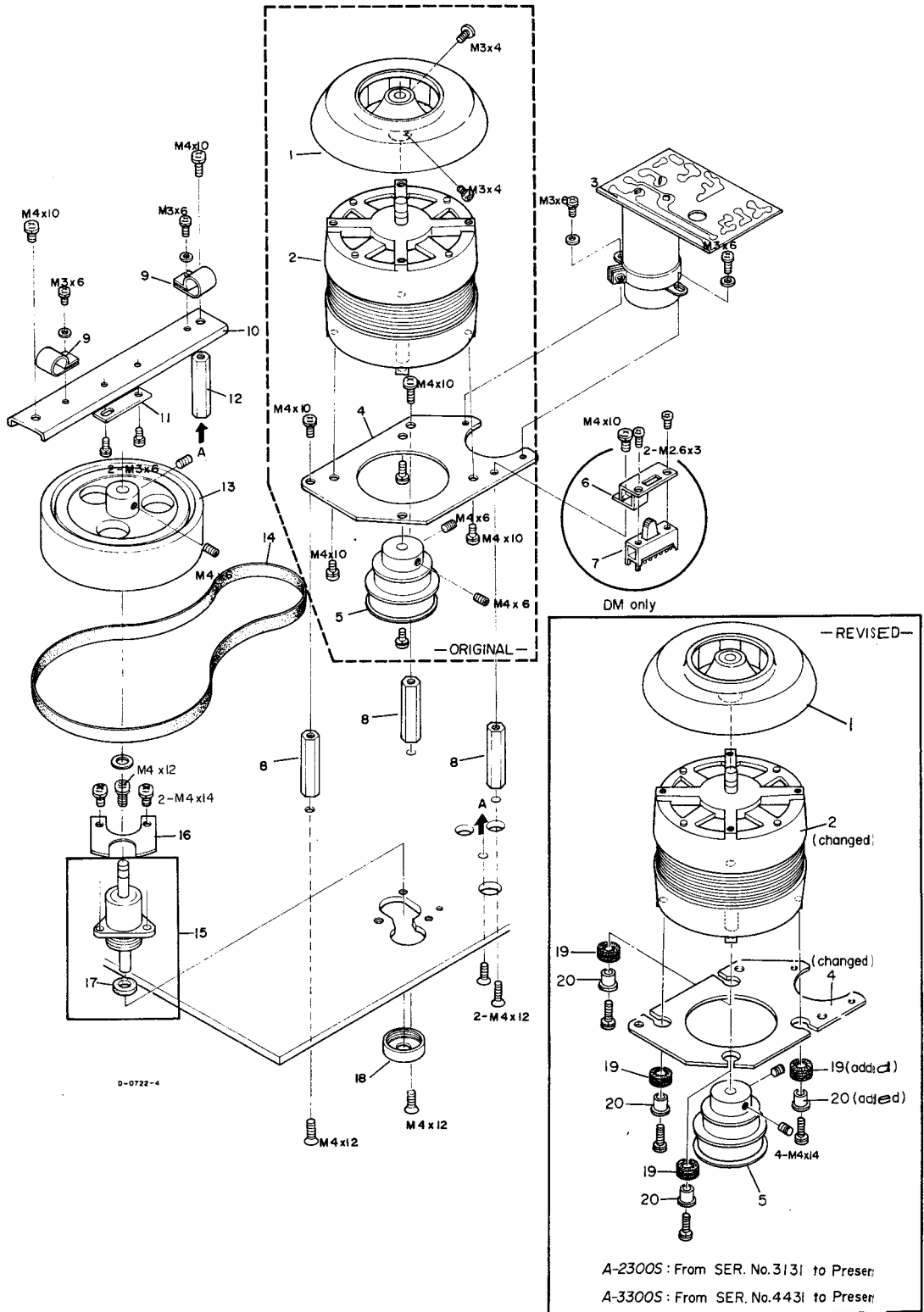

PARTS LIST-12

REF. NO.	ORIGINAL PARTS NO.	DESCRIPTION	REVISION
12 -1	50123982	Fan, Motor Cooling	
12- 2	50701341	Motor, Capstan	
12- 3	50545650	C, MP (2+0.8) μ F/250V	
	50491401	PC Bd, MP Capacitor	
12- 4	50123870	Plate, Capstan Motor	* 50237520
12- 5	50124003	Pulley, Motor (50Hz/60Hz) (DM)	
	50125121	Pulley, Motor (60Hz) (TCA)	
12- 6	50332380	Bracket, Slide SW (DM)	
12- 7	50444610	SW, Slide (DM)	
12- 8	50123850	Standoff, Capstan	
12- 9	50276280	Clamp, Wire	
12-10	50277151	Angle, Thrust	
12-11	50277231	Plate, Thrust	
12-12	50123860	Standoff, Flywheel	
12-13	50123802	Flywheel, Capstan	
12-14	50123830	Belt, Capstan (All exc. A-3300S-2T)	
	50125340	" , " (A-3300S-2T only)	
12-15	50120440	Capstan Assy (19cm/s) (All exc. A-3300S-2T)	
	50120450	" (38cm/s) (A-3300S-2T only)	
12-16	50142190	Plate, Arm Support	
12-17	50123900	Sponge, Oiler	
12-18	50123971	Cap, Dust, 6 ϕ (4T)	
	50125351	" , " , 12 ϕ (2T)	
12-19	(not used)	Cushion, Rubber	50706211 (added)
12-20	(not used)	Spacer, Rubber Cushion	50332790 (added)

NOTE: *The Capstan Motor Plate (12-4, revised P/N 50237520) requires the use of ref. numbers 12-19 and 12-20.

13. LIFTER AND PINCH ROLLER

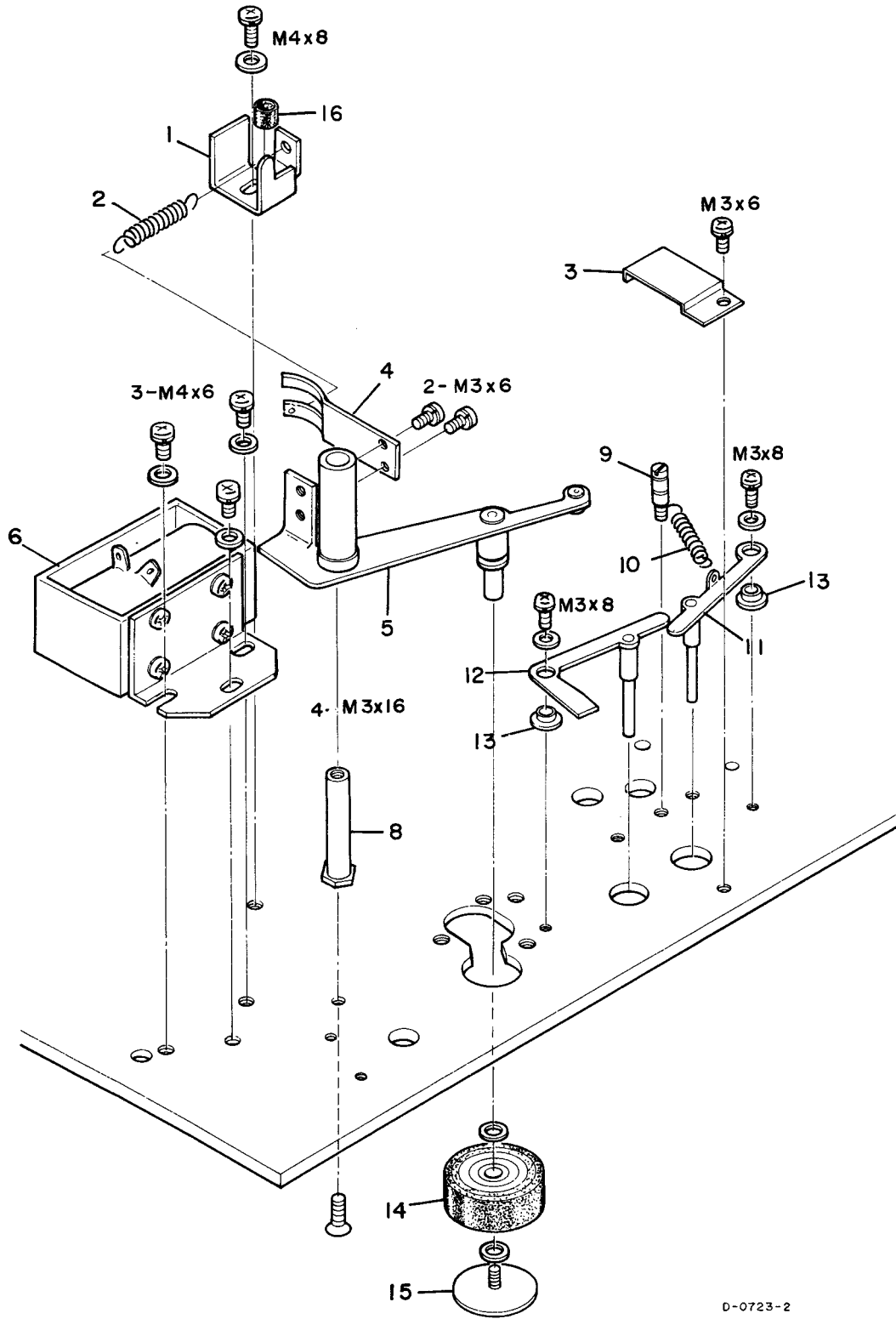

PARTS LIST-13

REF. NO.	ORIGINAL PARTS NO.	DESCRIPTION	REVISION
13- 1	50141842	Limit Stop, Pinch Roller	
13- 2	50220441	Spring	
13- 3	50152453	Plate, Lifter	
13- 4	50221152	Spring, Pressure	
13- 5	50140235	Arm Assy, Pinch Roller	* 50140236
13- 6	50616641	Solenoid Assy, Pinch Roller	** 50616760
13- 7		(not used)	
13- 8	50141821	Shaft, Roller Arm	
13- 9	50123140	Pin, Lifter Spring	
13-10	50221100	Spring, Lifter, A	
13-11	50150252	Arm, Lifter; B	
13-12	50150242	Arm, Lifter; A	
13-13	50152501	Shaft, Lifter Arm	
13-14	50141751	Pinch Roller	
13-15	50142180	Cap, Pinch Roller	
13-16	50275690	Cushion, Rubber	

*Not interchangeable. See explanation in the following figure.
 **Original and Later Solenoid Assy are interchangeable.

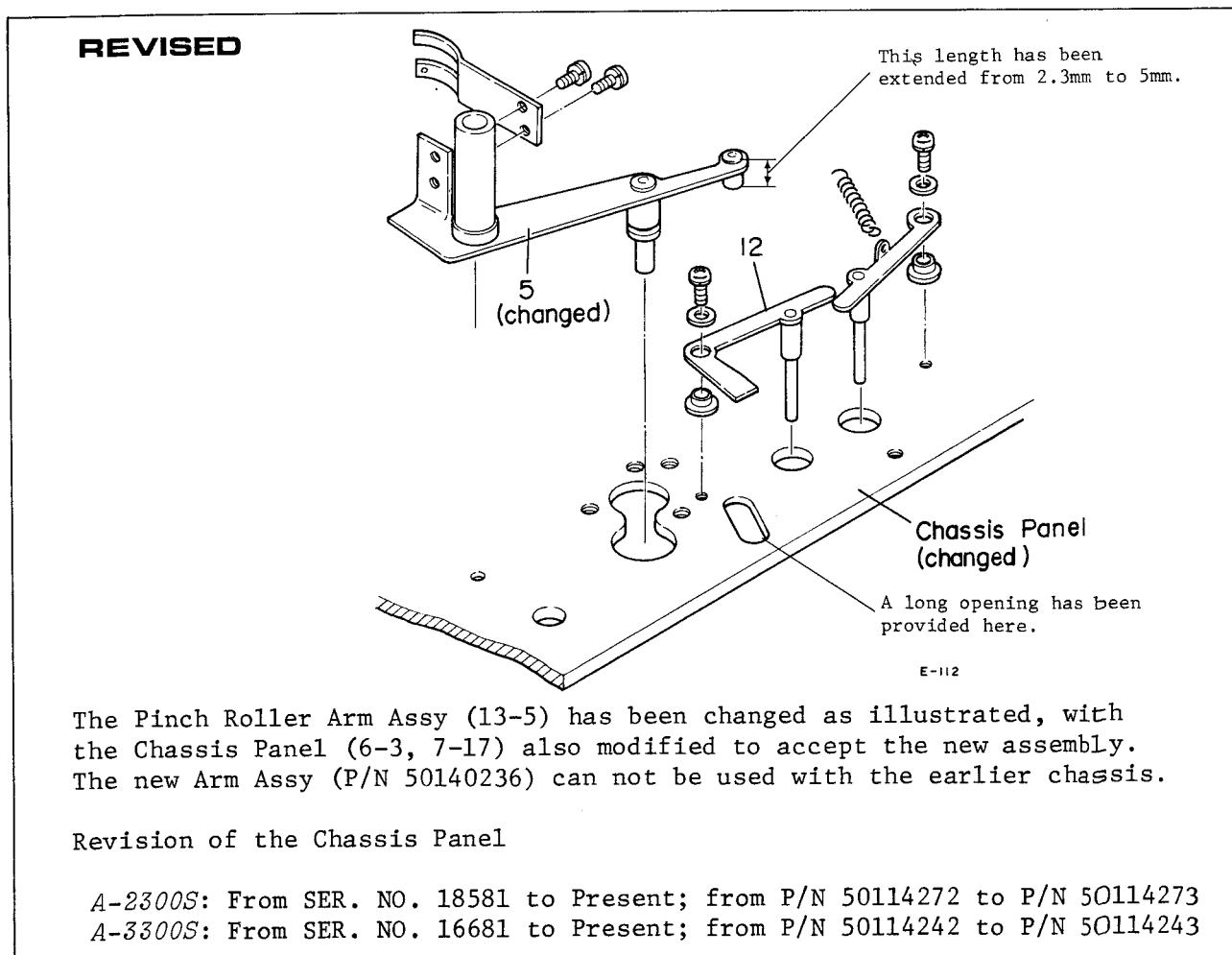

14. SUPPLIED ACCESSORIES

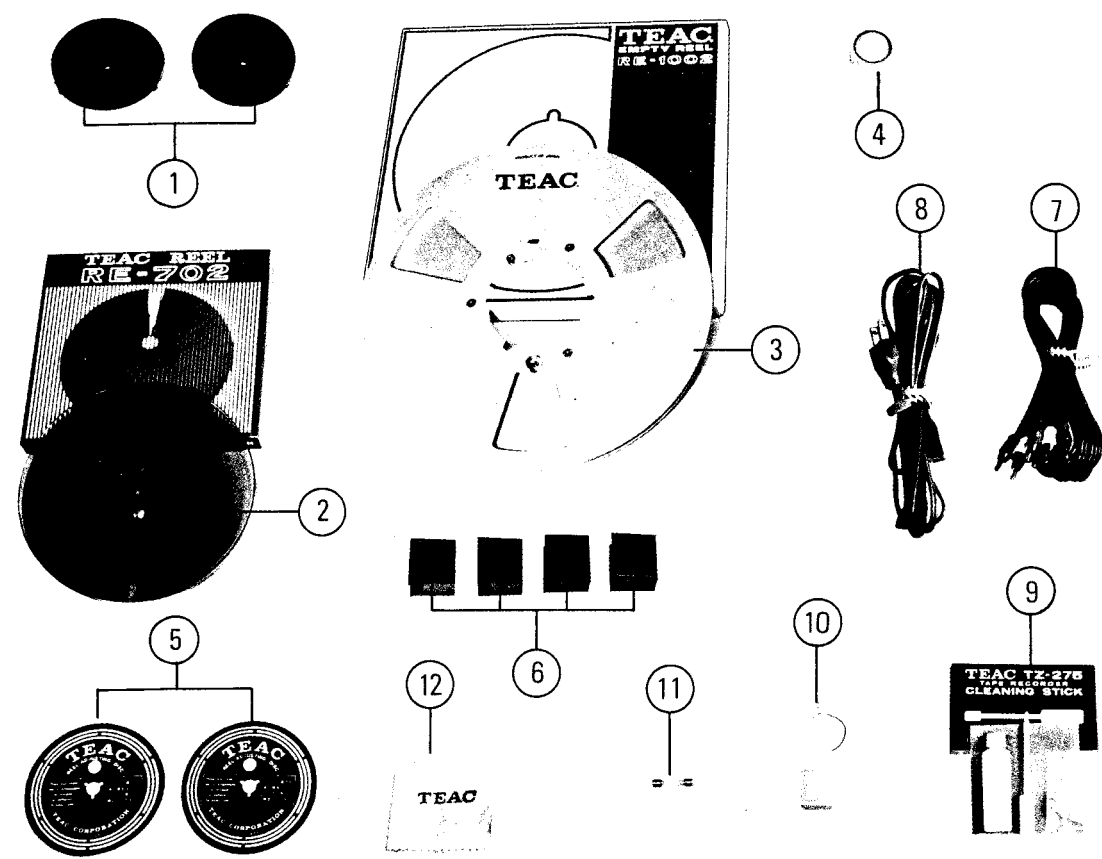

PARTS LIST-14

REF. NO.	ORIGINAL PARTS NO.	DESCRIPTION	REVISION
14- 1	50160270	Reel Adaptors, x2 (A-3300S)	
14- 2	*RE-702	Empty Reel, 7 inch, Small Hub (A-2300S)	
14- 3	*RE-1002	" , 10 inch (A-3300S)	
14- 4	50629620	Splicing Tape	
14- 5	50852120	Reel Adjusting Disc, x2	
14- 6	50276971	Rubber Feet (for Horizontal Use), x4	
14- 7	50471250	Input-Output Connection Cords, x2	
14- 8	50470772	AC Power Cord (DM)	
	50470501	" (TCA)	50478250
14- 9	57100300	Cleaning Stick (TZ-275)	
14-10	50291860	Oil and Applicator	
14-11	50411340	Fuse, 2A-250V (TCA·UL only)	
14-12	50291350	Silicone Cloth	
-----	51011651	A-2300S Instruction Manual (DM)	
-----	51012261	2300S " (TCA)	
-----	51011410	A-3300S " (DM)	
-----	51011421	3300S " (TCA)	

NOTE: The Empty Reels are available as Optional Accessories and thus are not assigned a special TEAC Parts number. Please order them by the MODEL CODE NUMBER (RE-702, RE-1002). These numbers are indicated on the packages.

PRINTED CIRCUIT BOARD PARTS LIST

A-2300S/A-3300S

NOTE

1. Several parts values have been changed by modifications. To obtain the correct part, always cross-reference with a Schematic Diagram and check the Circuit Reference number for possible revisions. The tape deck's Serial Number will be needed to confirm applicability as explained on the effected pages.
2. Do not include the Circuit Reference number with your order- it is included here for your reference use only.
3. Double designated circuit reference numbers indicate left channel/right channel (example: R101/201).

TEAC CORPORATION

1. MIC/PLAYBACK EQ. AMPLIFIER

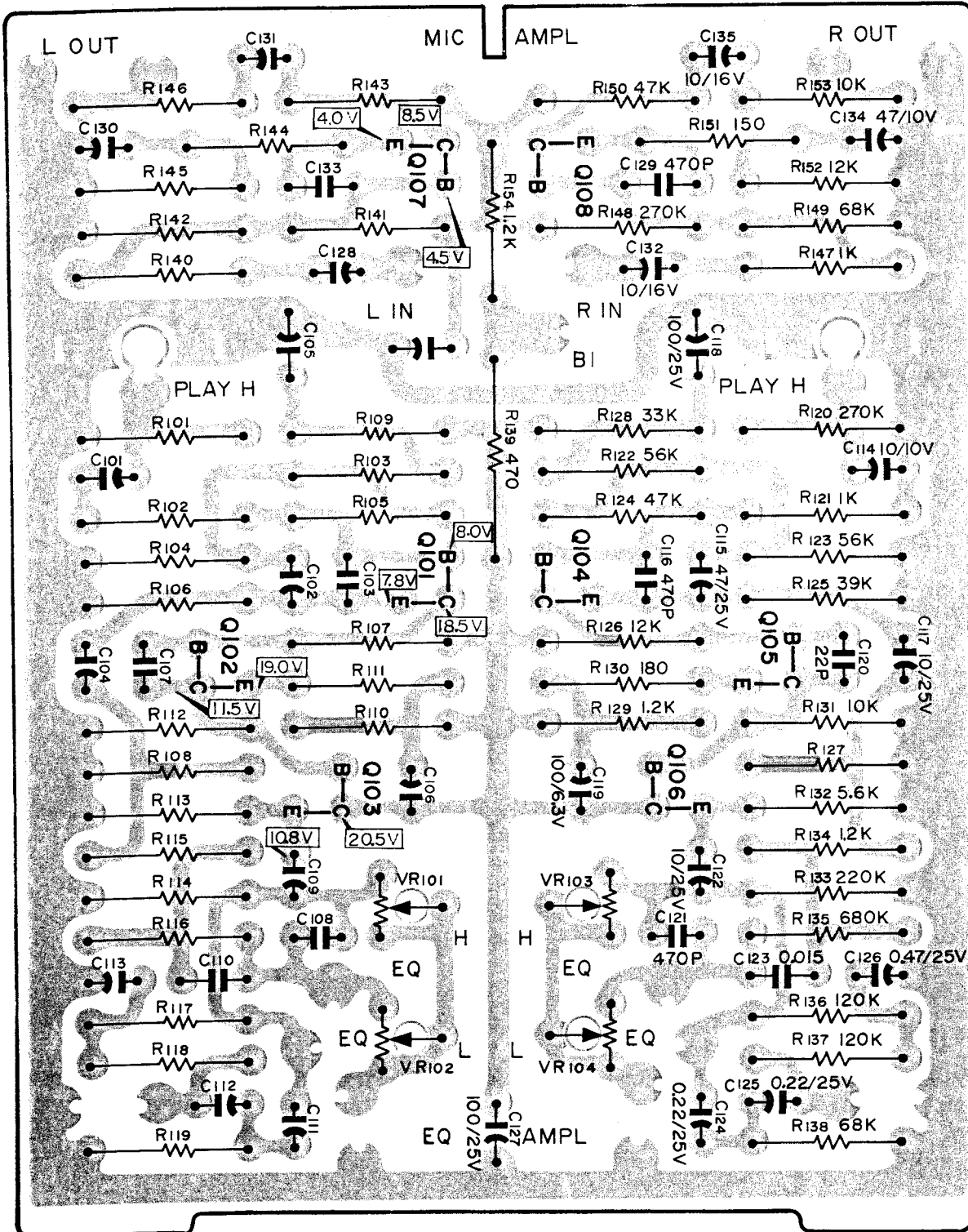

CIRCUIT REF.NO.	ORIGINAL PARTS NO. DESCRIPTION	REVISION	APPLICABILITY
	50491162 PC Bd. Assy, MIC/PB EQ Ampl.	⑤ 50491163	A-2300S-4T
	50490841 " " "	⑤ 50490842	A-3300S-4T
	50491250 " " "	④ 50491251	A-2300S-2T
	50490970 " " "	⑥ 50490971	A-3300S-2T
	50484080 PC Board		
	SILICON TRANSISTORS		
Q101/104	50424340 2SC1000-BL		
Q102/105	50423650 2SA494-Y		
Q103/106	50424600 2SC828-S		
Q107/108	50424340 2SC1000-BL		
	CARBON RESISTORS		
R101/120	50518890 270kΩ 1/4W 10%		
R102/121	50513430 1kΩ " "		
R103/122	50513990 56kΩ " "		
R104/123	50513990 56kΩ " "		
R105/124	50513870 47kΩ " "		
R106/125	50518850 39kΩ " "		
R107/126	50513580 12kΩ " "		
R108/127	50518780 220Ω " "	② 330Ω (50513360)	A-2300S-4T
	50513360 330Ω " "	→	A-3300S-4T
	50572760 560Ω " "	→	2T
R109/128	50518840 33kΩ " "		
R110/129	50513440 1.2kΩ " "		
R111/130	50518770 180Ω " "		
R112/131	50513570 10kΩ " "		
R113/132	50513880 5.6kΩ " "		
R114/133	50518880 220kΩ " "		
R115/134	50513440 1.2kΩ " "		
R116/135	50518930 680kΩ " "	① 270kΩ (50518890) ⑤ 180kΩ (50518380)	4T
	" " " "	④ 270kΩ (50518890)	A-2300S-2T
	" " " "	⑥ 470kΩ (50573460)	A-3300S-2T
R117/136	50573200 120kΩ 1/4W 10%	⑤ 33kΩ (50518840)	4T
	" " " "	→	2T
R118/137	" " " "	⑤ 33kΩ (50518840)	4T
	" " " "	→	2T
R119/138	50518860 68kΩ " "		
R139	50518790 470Ω " "		
R140/147	50513430 1kΩ " "		
R141/148	50518890 270kΩ " "		
R142/149	50518860 68kΩ " "		
R143/150	50513870 47kΩ " "		
R144/151	50513320 150Ω " "		
R145/152	50513580 12kΩ " "		
R146/153	50513570 10kΩ " "		
	TRIMMER RESISTORS		
VR101/103	50534130 6.8kΩ(B)	④ 10kΩ(B) (50533480)	A-2300S-2T only
	" " "	→	All etc. A-2300S-2T
VR102/104	50534140 15Ω(B)		All etc. A-3300S-2T
	50534130 6.8kΩ(B)		A-3300S-2T only
	CAPACITORS		
C101/114	50546193 Tant. 10μF 10V		
C102/115	50554030 Elec. 47μF 6.3V		
C103/116	50547560 Polyst. 470pF 50V		
C104/117	50549700 Elec. 10μF 25V		
C105/118	50549740 Elec. 100μF 25V		

CIRCUIT REF.NO.	ORIGINAL PARTS NO.	DESCRIPTION	REVISION	APPLICABILITY
C106/119	50554230	Elec. 100 μ F 6.3V		
C107/120	50543820	Polyst. 22pF 50V		
C108/121	50547560	Polyst. 470pF 50V		
C109/122	50549700	Elec. 10 μ F 25V		
C110/123	50548420	Mylar 0.015pF 50V		
C111/124	50546662	Dip. Tant. 0.22 μ F 25V	⑤ 1 μ F 35V (50546701)	4T
	"	"	→	2T
C112/125	50546662	Dip. Tant. 0.22 μ F 25V	⑤ 1 μ F 35V (50546701)	4T
	"	"	→	2T
C113/126	50546689	Tant. 0.47 μ F 16V		
C127/136	50554170	Elec. 100 μ F 25V		
C128/132	50554050	Elec. 10 μ F 6V		
C129/133	50547560	Polyst. 470pF 50V		
C130/134	50554030	Elec. 47 μ F 6.3V		
C131/135	50554050	Elec. 10 μ F 6V		

NOTE: 1. The circled numbers above (in the REVISION column) correspond to those in the following table.

A-2300S-4T	① From SER. NO. 10481	A-2300S-2T	④ From SER. NO. 15581 to Present
	② From SER. NO. 11081		
	⑤ From SER. NO. 14881 to Present		
A-3300S-4T	① From SER. NO. 8881	A-3300S-2T	⑥ From SER. NO. 12381 to Present
	⑤ From SER. NO. 11881 to Present		

2. All revised electrical components resulted from the head parts change (including Heads). For details, see HEAD ASSEMBLY (page 8 in PARTS LIST) and the SERVICE MANUAL REVISION NOTICE - orange colored sheet - at the rear of this PARTS LIST.

2. METER/REC.EQ.AMPLIFIER

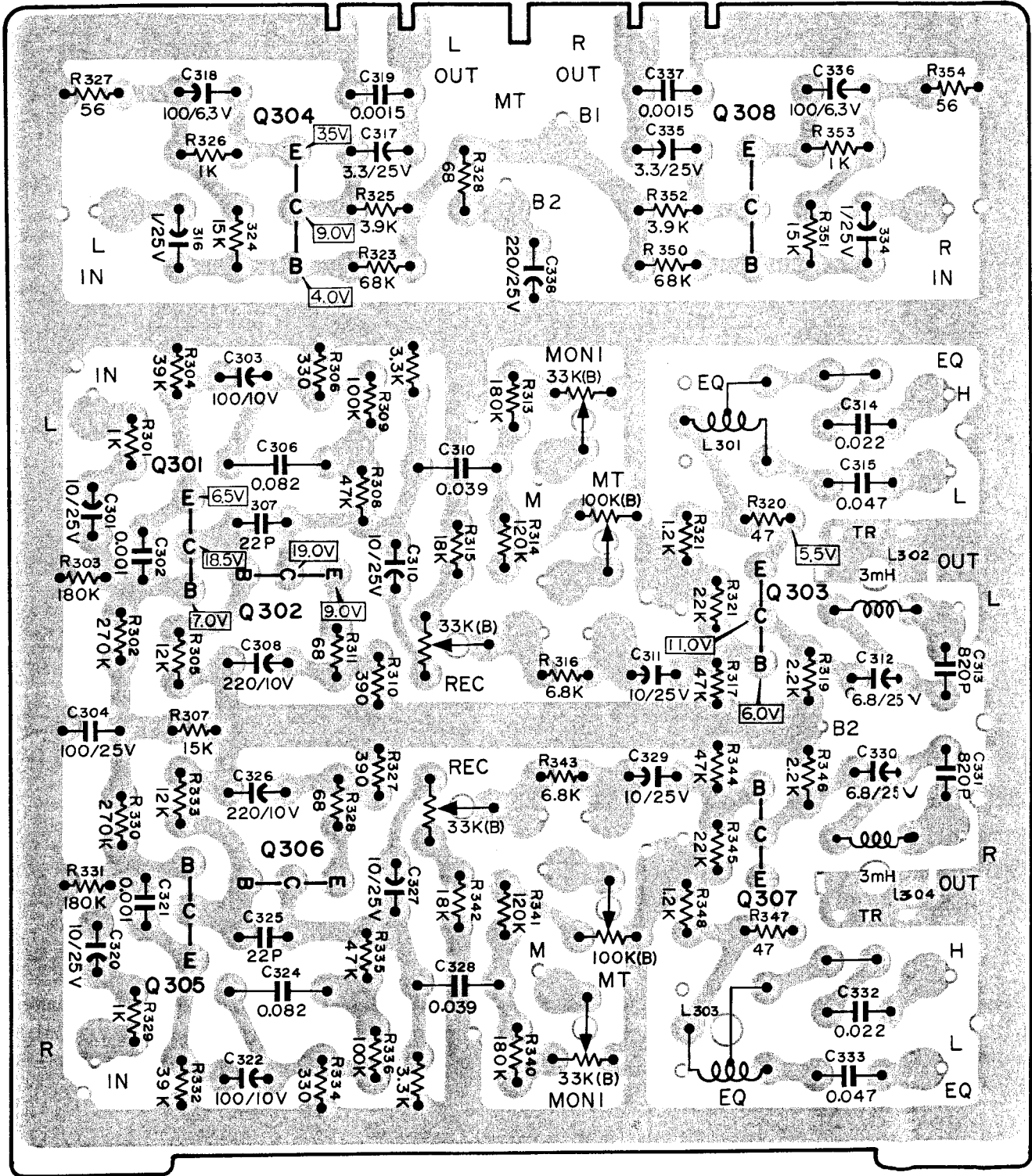

ORIGINAL

CIRCUIT REF.NO.	ORIGINAL PARTS NO. DESCRIPTION	REVISION	APPLICABILITY
	50491184 PC Bd. Assy	③ 50491185 ⑤ 50491186	A-2300S-4T
	50490864 " "	③ 50490865 ⑤ 50490866	A-3300S-4T
	50491275 " "	④ 50491276	A-2300S-2T
	50490964 " "	⑥ 50490965	A-3300S-2T
	50484102 PC Board		
	SILICON TRANSISTORS		
Q301/305	50423870 2SC639-G		
Q302/306	50423650 2SA494-Y		
Q303/304	50424600 2SC828-S		
Q307/308	50424600 2SC828-S		
	CARBON RESISTORS		
R301/329	50570820 1kΩ 1/4W 10%		
R302/330	50571400 270kΩ " "		
R303/331	50571360 180kΩ " "		
R304/332	50571200 39kΩ " "		
R305/333	50571080 12kΩ " "		
R306/334	50570700 330Ω " "		
R307/324	50571100 15kΩ " "		
R308/335	50571220 47kΩ " "		
R309/336	50571300 100kΩ " "		
R310/337	50570720 390Ω " "		
R311/338	50570540 68Ω " "		
R312/339	50570940 3.3kΩ " "		
R313/340	50571360 180kΩ " "		
R314/341	50571320 120kΩ " "		
R315/342	50571120 18kΩ " "	② 6.8kΩ (50571020)	All
R316/343	50571020 6.8kΩ " "		
R317/344	50571220 47kΩ " "		
R318/345	50571120 18kΩ " "		
R319/346	50570900 2.2kΩ " "		
R320/347	50570500 47Ω " "		
R321/348	50570840 1.2kΩ " "		
R322/349	Jumper	③ 150Ω (50515240)	4T
	Jumper	④ 100Ω (50515220)	A-2300S-2T
	50570220 33Ω 1/4W 10%	⑥ 180Ω (50570640)	A-3300S-2T
R323/350	50571260 68kΩ " "		
R325/352	50570960 3.9kΩ " "		
R326/353	50570820 1kΩ " "		
R327/354	50570520 56Ω " "		
R328	50570540 68Ω " "		
R351	50571100 15kΩ " "		
	TRIMMER RESISTORS		
VR301/304	50534120 33kΩ(B)		
VR302/305	50533490 100kΩ(B)		
VR303/306	50533520 47kΩ(B)		A-2300S
	50534120 33kΩ(B)		A-3300S
	CAPACITORS		
C301/320	50554040 Elec. 10μF 25V		
C302/321	50548320 Mylar 0.001μF 50V		
C303/322	50554570 Elec. 100μF 10V		
C304	50554170 Elec. 100μF 25V		
C305/323	50543510 Polyst. 33pF 50V		
C306/324	50548370 Mylar 0.082μF 50V	② 0.056μF 50V (50548460) ⑤ 0.047μF 50V (50548270)	4T
	" " " "	② 0.056μF 50V (50548460)	A-2300S-2T
	" " " "	② 0.056μF 50V (50548460) ⑥ 0.082μF 50V (50548370)	A-3300S-2T
C307/325	50543330 Polyst. 22pF 50V		
C308/326	50554910 Elec. 220μF 10V		
C309/327	50549700 Elec. 10μF 25V		
C310/328	50548630 Mylar 0.039μF 50V	② 0.027μF 50V (50548330)	All exc. A-3300S-2T
	" " " "	② 0.027μF 50V (50548330) ⑥ 0.033μF (50548240)	A-3300S-2T only
C311/329	50554040 Elec. 10μF 25V		
C312/330	50546621 Tant. 6.8μF 25V		
C313/331	50543440 Polyst. 820pF 50V		
C314/332	50548240 Mylar 0.033μF 50V	→	4T
	50548290 Mylar 0.022μF 50V	④ 0.015μF 50V (50548420)	A-2300S-2T
	50548620 Mylar 0.012μF 50V	① 0.0068μF 50V (50548570)	A-3300S-2T

CIRCUIT REF.NO.	ORIGINAL PARTS NO. DESCRIPTION	REVISION	APPLICABILITY
C315/333	50548270 Mylar 0.047 μ F 50V	① 0.033 μ F 50V (50548240)	4T
	50548460 Mylar 0.056 μ F 50V	④ 0.022 μ F 50V (50548290)	A-2300S-2T
	50548330 Mylar 0.027 μ F 50V	① 0.022 μ F 50V (50548290)	A-3300S-2T
C316/334	50555470 Elec. 1 μ F 25V		
C317/335	50554140 Elec. 3.3 μ F 25V		
C318/336	50554230 Elec. 100 μ F 6.3V		
C319/337	50548120 Mylar 0.0015 μ F 50V		
C338	50555520 Elec. 220 μ F 25V		
	COILS		
L301/303	50566370 Rec. EQ 2.4/4.2mH		All exc. A-3300S-2T
	50566670 Rec. EQ 1.5/2.4mH		A-3300S-2T only
L302/304	50566300 Trap 3mH		

NOTE: 1. The circled numbers above (in the REVISION column) correspond to those in the following table.

A-2300S-4T	① From SER. NO. 10481	A-2300S-2T	② From SER. NO. 11081
	② From SER. NO. 11081		④ From SER. NO. 15581 to Present
	③ From SER. NO. 9681		
	⑤ From SER. NO. 14881 to Present		
A-3300S-4T	① From SER. NO. 8881	A-3300S-2T	① From SER. NO. 8881
	② From SER. NO. 10281		② From SER. NO. 10281
	③ From SER. NO. 8181		⑥ From SER. NO. 12381 to Present
	⑤ From SER. NO. 11881 to Present		

2. All revised electrical components resulted from the head parts change (including Heads). For details, see HEAD ASSEMBLY (page 8 in PARTS LIST) and the SERVICE MANUAL REVISION NOTICE - orange colored sheet - at the rear of this PARTS LIST.

3. LINE OUT/PHONE AMPLIFIER

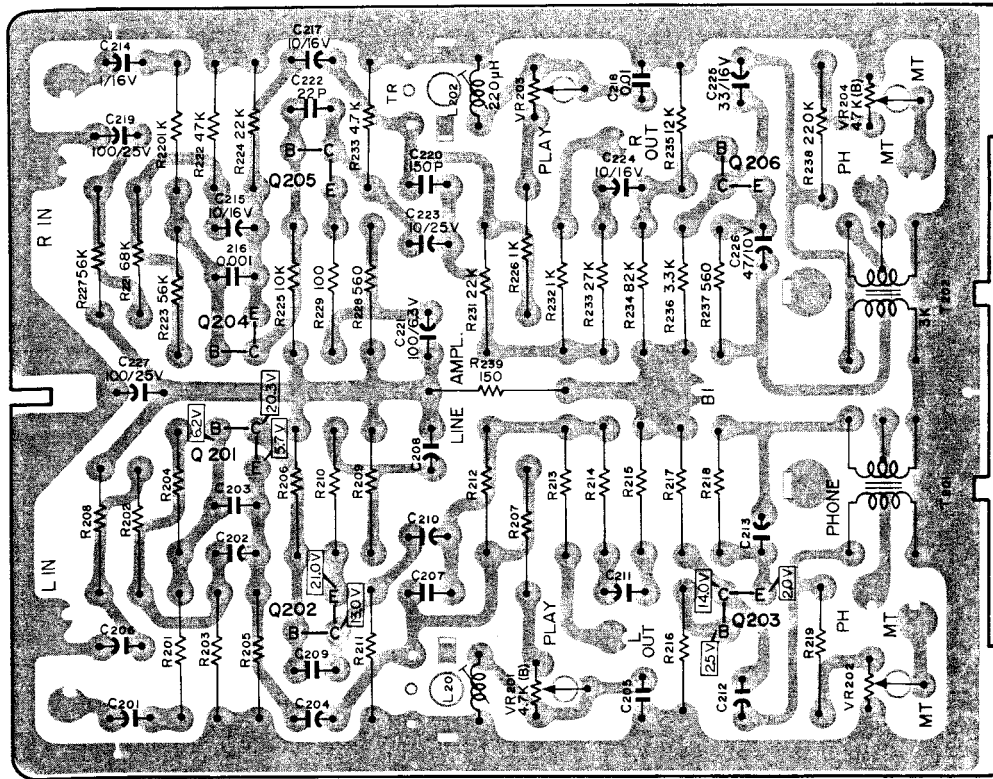

9-013

CIRCUIT REF. NO.	ORIGINAL PARTS NO.	DESCRIPTION	REVISION
	50491260	PC Bd. Assy, Line Out/Phone Ampl.	(A-2300S-4T)
	50490850	"	(A-3300S-4T)
	50491170	"	(A-2300S-2T)
	50490980	"	(A-3300S-2T)
	50484090	PC Board	
	SILICON TRANSISTORS		
Q201/204	50423870	2SC693-G	
Q202/205	50423800	2SA564-R	
Q203/206	50423830	2SC536-F	
	CARBON RESISTORS		
R201/220	50513430	1k Ω	1/4W 10%
R202/221	50518860	68k Ω	" "
R203/222	50513870	47k Ω	" "
R204/223	50513990	56k Ω	" "
R205/224	50513930	22k Ω	" "
R206/225	50513570	10k Ω	" "
R207/226	50513430	1k Ω	" "
R208/227	50513990	56k Ω	" "

CIRCUIT REF.NO.	ORIGINAL PARTS NO.	DESCRIPTION	REVISION
R209/228	50513910	560Ω 1/4W 10%	
R210/229	50513300	100Ω " "	
R211/230	50513970	4.7kΩ " "	
R212/231	50513930	22kΩ " "	
R213/232	50513920	680Ω " "	
R214/233	50513860	27kΩ " "	
R215/234	50518870	82kΩ " "	
R216/235	50513580	12kΩ " "	
R217/236	50513960	3.3kΩ " "	
R218/237	50513910	560Ω " "	
R219/238	50518880	220kΩ " "	
R239	50513320	150Ω " "	
TRIMMER RESISTORS			
VR201/203	50533460	4.7kΩ(B)	
VR202/204	50533520	47kΩ(B)	
CAPACITORS			
C201/214	50549660	Elec. 1μF 25V	
C202/215	50546562	Tant. 10μF 16V	
C203/216	50548320	Mylar 0.001μF 50V	
C204/217	50554050	Elec. 10μF 16V	
C205/218	50548020	Mylar 0.01μF 50V	
C206/219	50554170	Elec. 100μF 25V	
C207/220	50547440	Polyst. 100pF 50V	
C208/221	50554230	Elec. 100μF 6.3V	
C209/222	50543820	Polyst. 22pF 50V	
C210/223	50554040	Elec. 10μF 25V	
C211/224	50554050	Elec. 10μF 16V	
C212/225	50554260	Elec. 33μF 16V	
C213/226	50554030	Elec. 47μF 6.3V	
C227	50554170	Elec. 100μF 25V	
COILS			
L201/202	50566640	Trap 220μH	
TRANSFORMERS			
T201/202	50562141	Headphone 3kΩ:8Ω	

4. CONTROL RELAY-1

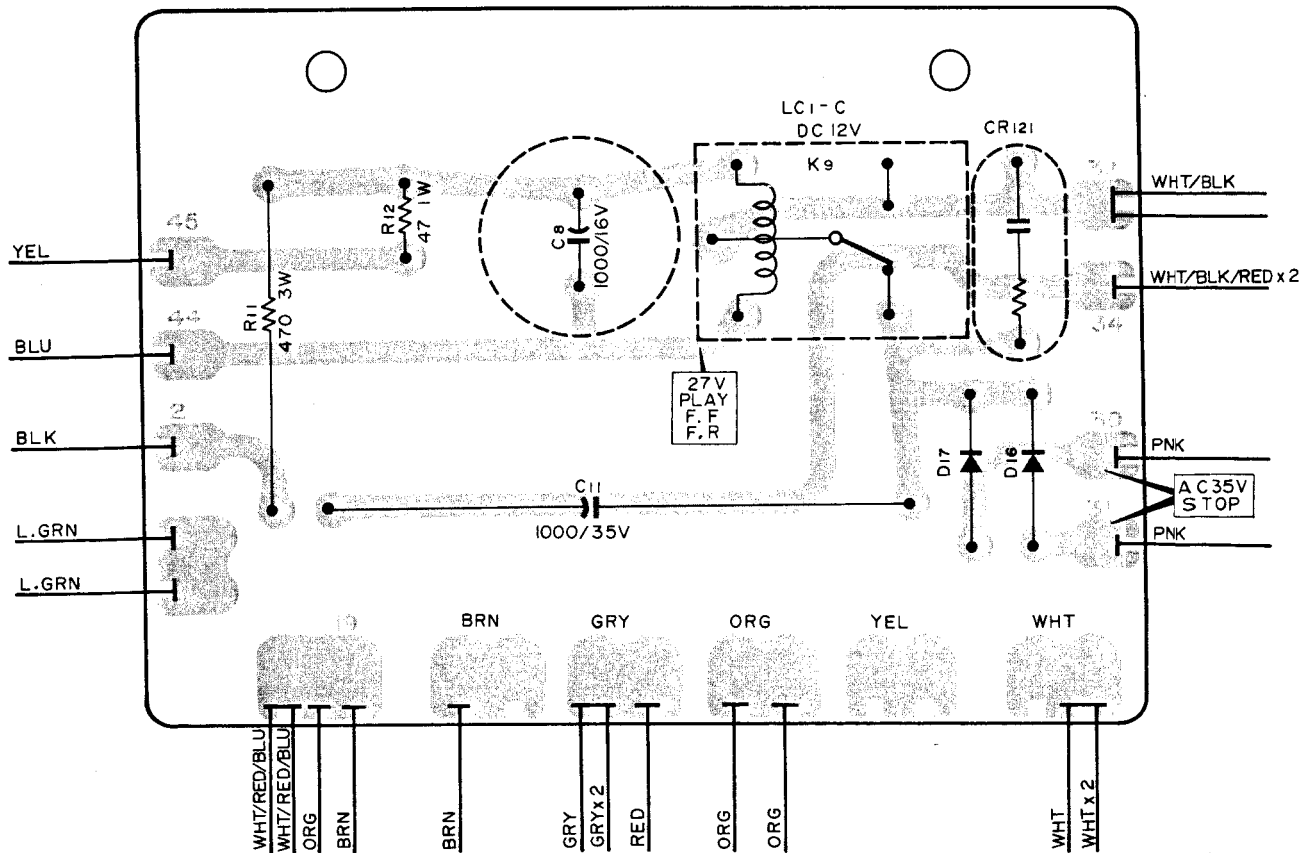

P-014

CIRCUIT ORIGINAL			REVISION
REF. NO.	PARTS NO.	DESCRIPTION	
	50490912	PC Bd. Assy, Control Relay-1 (A-3300S)	
	50491190	" , " (A-2300S)	
	50484070	PC Board	
K9	50611130	Relay, LC1-C DC-12V	
D16•D17	50422560	Diode, SIB01-02	
R11	50527140	R, Metallized 470Ω 3W	
R12	50526140	R, Wire wound 47Ω 1/2W	
C8	50554890	C, Elec. 1000μF 16V	
C11	50555110	C, Elec. 1000μF 35V	
CR121	50529050	Spark Killer, 0.1μF+120Ω 400V	

5. CONTROL RELAY-2

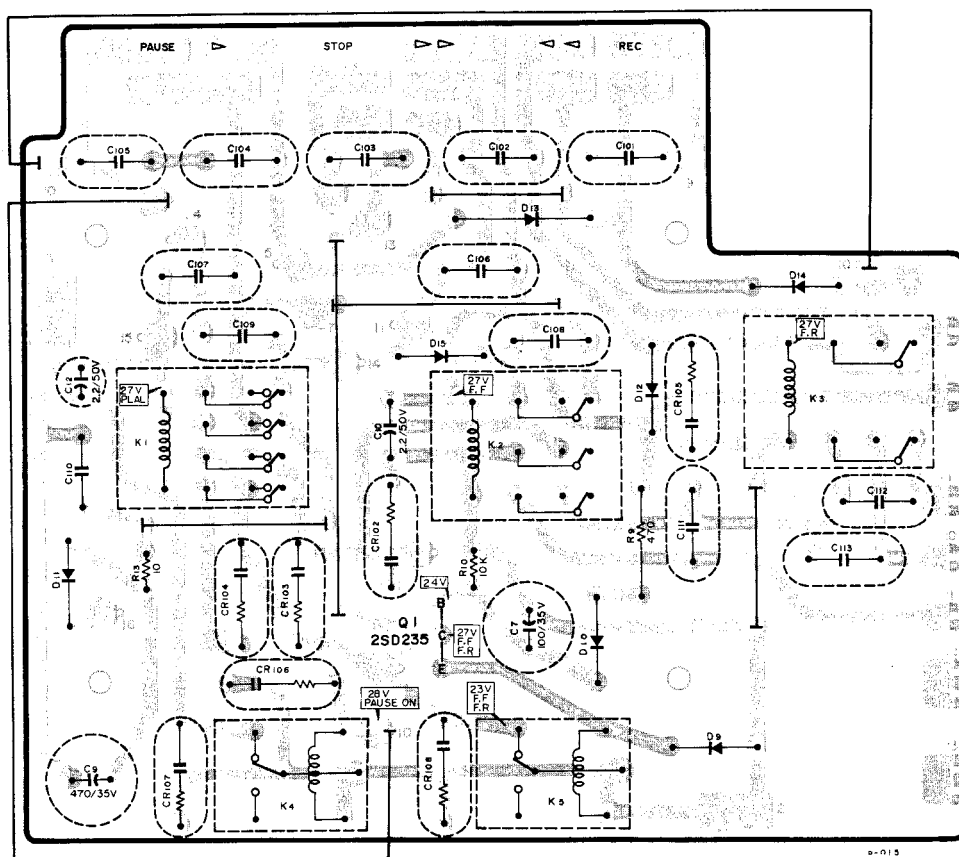

CIRCUIT REF.NO.	ORIGINAL PARTS NO.	DESCRIPTION	REVISION
	50491020	PC Bd. Assy, Control Relay-2 (A-2300S)	51680651 (From SER.No. 9681)
	50490890	" , " (A-3300S)	
	50484130	PC Board (A-2300S)	51670621 (From SER.No. 9681)
	"	" (A-3300S)	
Q1	50424620	Transistor, 2SD235-Y	
K1	50611180	Relay, MY4-0 DC-24V	
K2	50611120	Relay, MY3-0 DC-24V	
K3	50611140	Relay, MY2-0 DC-24V	
K4	50611150	Relay, LC1-C DC-24V	
K5	50611170	Relay, LC1-C DC-24V	
D9•10•11	50422560	Diode, SIB01-02	
D12•13	50422560	Diode, SIB01-02	
D14•15	50422560	Diode, SIB01-02	
R9	50574740	R, Carbon 470Ω 1/2W	
R10	50570560	R, Carbon 10kΩ 1/2W	
R13	50525720	R, Wire Wound 10Ω 1/2W (A-3300S only)	
C7	50554630	C, Elec. 100μF 35V	
C9	50554620	C, Elec. 470μF 35V (A-3300S only)	
C10•12	50554980	C, Elec. 2.2μF 50V	
C101~105	50549920	C, Mylar 0.1μF 400V	
C107~113	50549920	C, Mylar 0.1μF 400V	
VR102~108	50529050	Spark Killer 0.1μF+120Ω 400V	

6. POWER SUPPLY

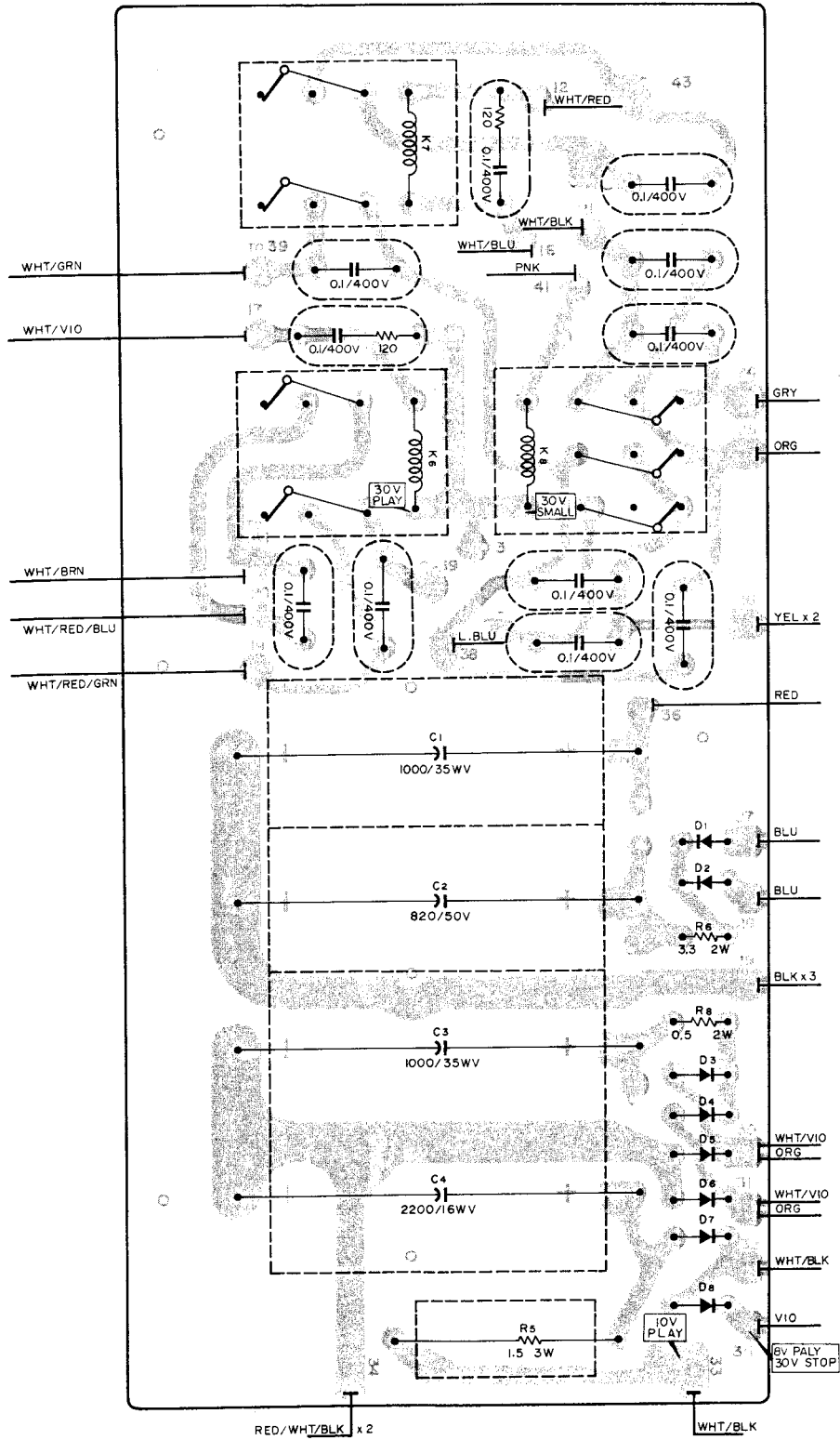

CIRCUIT REF.NO.	ORIGINAL PARTS NO.	DESCRIPTION	REVISION
	50490921	PC Bd. Assy, Power Supply (A-3300S)	
	50491031	" , " (A-2300S)	
	50484170	PC Board	
K6	50611140	Relay, MY2-0 DC-24V	
K7	50611160	Relay, MY2-0 DC-24C (A-3300S)	
K8	50611120	Relay, MY3-0 DC-24V (A-3300S)	
R5	50520340	R, Cement 1.5Ω 3W	
R6	50525440	R, Wire Wound 3.3Ω 1W	
R8	50526150	R, Wire Wound 0.5Ω 2W	
D1~D6	50422560	Diode, SIB01-02	
D7~D8	50422570	Diode, SIB01-06	
C1~C3	50555110	C, Elec. 1000μF 35V	
C2	[50555670]*	C, Elec.[820μF 50V]*	1000μF 50V(50555700)
C4	50555660	C, Elec. 2200μF 16V	
C301~309	50548390	C, Mylar 0.1μF 400V	
CR301~303	50529050	Spark Killer 0.1μF+120Ω 400V	

* Typographical error in original PARTS LIST. Do not order this number.

7. VOLTAGE REGULATOR

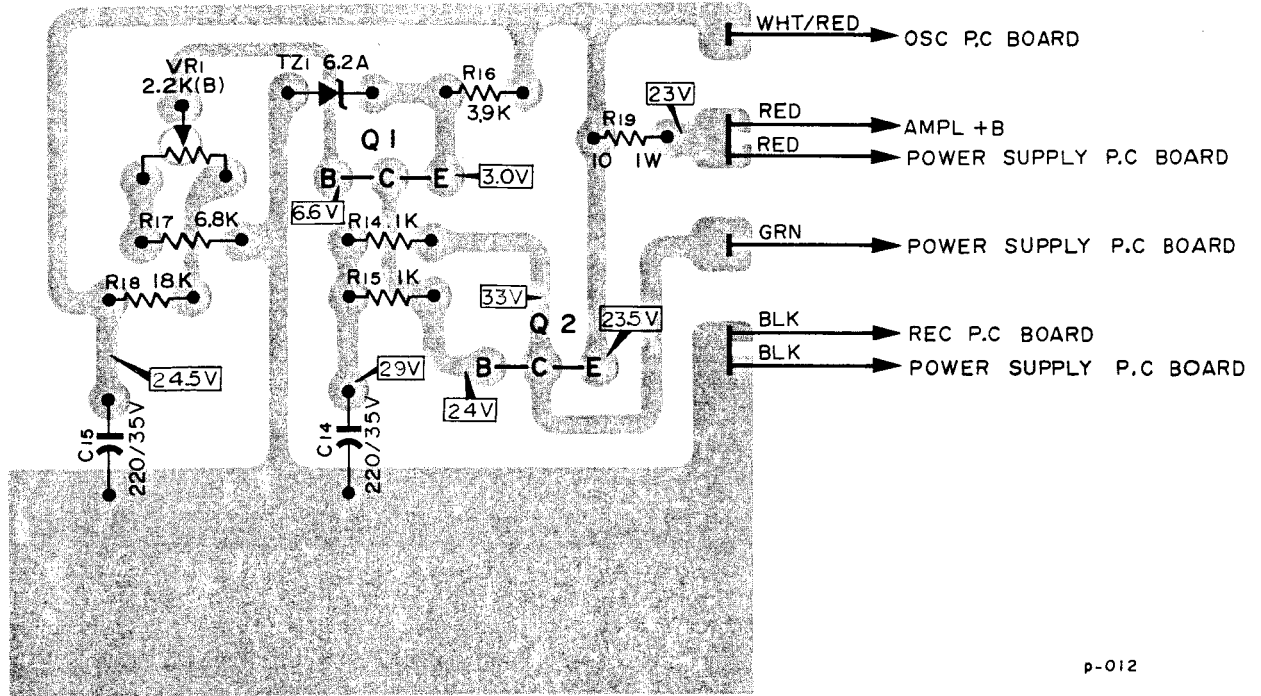

CIRCUIT REF. NO.	ORIGINAL PARTS NO.	DESCRIPTION	REVISION
	50491050	PC Bd. Assy, Voltage Regulator	
	50484200	PC Board	
Q1	50423510	Transistor, 2SC733-Y	
Q2	50424270	Transistor, 2SD317-P	
VR1	50533640	Trimmer Resistor, 2.2k Ω (B)	
TZ1	50422580	Diode, 02Z 6.2A	
R14	50515340	R, Carbon 1k Ω 1/4W	
R15	50515340	R, Carbon 1k Ω 1/4W	
R16	50515430	R, Carbon 3.9k Ω 1/4W	
R17	50515490	R, Carbon 6.8k Ω 1/4W	
R18	50515520	R, Carbon 18k Ω	
R19	50526120	R, Wire Wound 10 Ω 1W	
C14	50554380	C, Elec. 220 μ F 35V	
C15	50554380	C, Elec. 220 μ F 35V	

8. BIAS OSCILLATOR

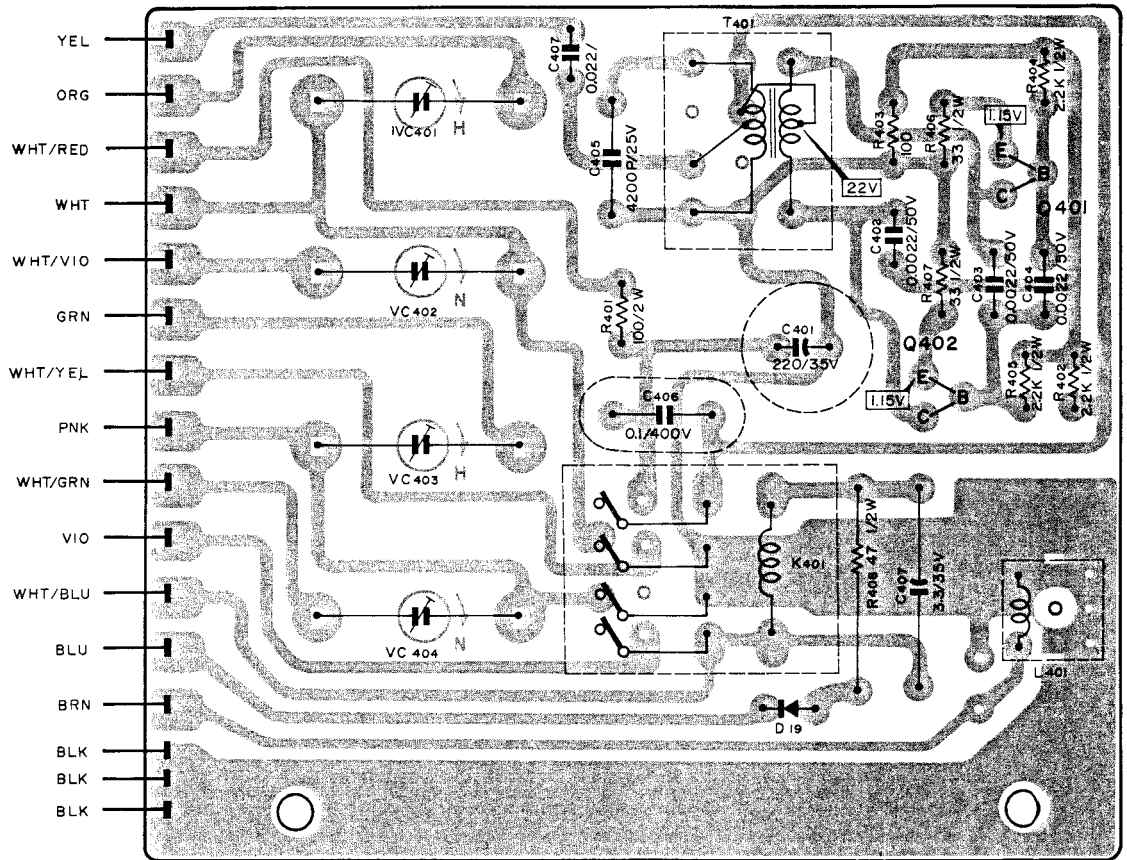

P-016

CIRCUIT REF.NO.	ORIGINAL PARTS NO.	DESCRIPTION	REVISION
	50490870	PC Bd. Assy, Bias Oscillator	
	50484110	PC Board	
Q401•402	[50423850]*	Transistor[2SC971]*	2SC1384(50424750)
T401	50563170	Coil, Oscillator	
K401	50611180	Relay, DC 24V, MY4-0 4T	
D19	50422560	Diode, SIB01-02	
VC401/402	50547070	Trimmer Capacitor, 80pF	
VC403/404	50547070	Trimmer Capacitor, 80pF	
C401	50554380	C, Elec. 220µF 35V	
C402/403	50548760	C, Mylar 0.0022µF 50V	
C404	50548810	C, Mylar 0.0033µF 50V	
C405	50544040	C, Polyst. 4200pF 250V	
C406	50549920	C, Elec. 0.1µF 400V	
C406	50548740	C, Mylar 0.022µF 150V	
C407	50555680	C, Elec. 3.3µF 35V	
R401	50526050	R, Wire Wound 33Ω 2W	
R402	50516380	R, Carbon 2.2kΩ 1/2W	
R403	50516220	R, Carbon 100Ω 1/2W	
R404•405	50515380	R, Carbon 2.2kΩ 1/4W	
R406•407	50516150	R, Carbon 33Ω 1/2W	
R408	50514860	R, Carbon 47Ω 1/2W	
L401	50566680	Coil, Dummy Load 2.1mH	

* Typographical error in original PARTS LIST. Do not order this number.

MANUAL CHANGES

Change notices, recommended modifications etc. will be issued for the models in this manual, when appropriate. These changes are in loose leaf form and should be filed behind this page for convenient reference.

SERVICE MANUAL REVISION NOTICE

TEAC Models (A-)2300S and (A-)3300S have had significant design changes in parts and circuitry, effective from Serial Numbers given below. These changes effect the Bias Adjustment Procedures for the applicable units; revised procedures are given in this Notice.

Modification was effective from the following Serial Numbers.

(A-)2300S (4T) #10481 [first change] #14881 [second change]
(A-)2300S 2T #15881
(A-)3300S (4T) #8881 [first change] #11881 [second change]
(A-)3300S 2T #12381

IMPORTANT: BEFORE PERFORMING THE "BIAS ADJUSTMENT PROCEDURES" and BEFORE ORDERING PARTS for any (A-)2300S or (A-)3300S, COMPARE THE SERIAL NUMBER WITH THOSE ABOVE.
If the number is higher than those given, new parts numbers are applicable and the Bias Adjustment Procedure is greatly changed for the 4T models.

SUMMARY OF THE CHANGES

From the first change, alignment tape for recording adjustments was changed to TEAC Test Tape YTT-8003. This tape should be available from your distributor soon. Its characteristics are identical with the Fuji brand, type FB-151 recording tape.

Circuitry has been changed in the Record Level, Record Equalization, and Playback Equalization circuitry to optimize performance at the HIGH position of the BIAS switch. Head contour is changed, but material is identical.

Bias adjustment procedures are changed only for the 4 track head configuration models, and only for those units following the applicable serial numbers indicated.

REVISED - BIAS ADJUSTMENT PROCEDURE

[Applicable for (A-)2300S (4T) from Serial #10481 and for (A-)3300S-(4T) from Serial #8881 only.]

NOTE: Adjust the Bias Traps before proceeding.
Bias oscillator frequency is 100 kHz \pm 5 kHz.
Bias Adjustment is performed only at the Tape Speed of 3-3/4ips (9.5 cm/s).

Preparation:

1. Thread a recording Test Tape YTT-8003 (Fuji FB-151) on the unit.
2. Set the controls on the deck as outlined below:
 - a. SPEED SW \rightarrow 3-3/4ips (9.5 cm/s)
 - b. MONITOR SW \rightarrow TAPE
 - c. BIAS SW \rightarrow HIGH
 - d. EQ SW \rightarrow HIGH
 - e. OUTPUT Level Controls - Specified Setting

Procedures:

3. Apply a 7 kHz signal at -18 dB (10 dB below the Specified Input Level) to the LINE IN jacks.
4. While recording, adjust capacitor VC-401/403 for a peak reading on the Test Set. From that peak, turn the capacitor clockwise until a decrease of 2.5 dB is obtained. (N.B.: Will be overbiased as preferred.)

IMPORTANT: These revised procedures, using the YTT-8003 tape, must be used with the other procedures in the basic SERVICE MANUAL. They replace the BIAS ADJUSTMENT procedures only for units with the applicable serial numbers given above.

NOTE: Several component changes exist in the units affected by this change. See the accompanying changes listed on other sheets of this SERVICE MANUAL REVISION NOTICE for details which you should note in the PARTS LIST and SCHEMATIC DIAGRAMS of your basic manuals.

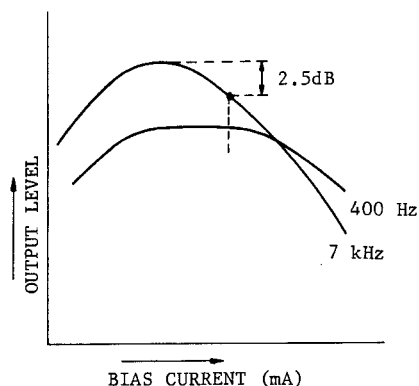

BIAS Limits Chart

PARTS COMPARISON CHART

This chart is to assist comparison of the original parts with those used after the design changes. When ordering parts, note these points:

1. Always include the complete model number and serial number.
2. There is no interchangeability between the various Record or Playback heads; use only the part number specified for the given serial number.
3. This factory change should not be performed at any level on those units not having it; this is not a modification.

A-2300S/A-3300S 2 TRACK

MODELS	A-2300S		A-3300S	
Beginning with SERIAL NUMBER	(1st prod.) #2301	#15881	(1st prod.) #3326	#12381
Head Record Playback	50665040 50668050	50662150 50662250	50665040 50668050	50662120 50662220
Blank Tape HIGH NORMAL	SCOTCH 203 SCOTCH 150	YTT-8003 SCOTCH 150	SCOTCH 203 SCOTCH 150	YTT-8003 SCOTCH 150
Circuit REF.NO.				
R108/127	560Ω	560Ω	560Ω	560Ω
R116/135	680kΩ	270kΩ	680kΩ	470kΩ
R117/136	120kΩ	120kΩ	120kΩ	120kΩ
R118/137	120kΩ	120kΩ	120kΩ	120kΩ
C111/124	0.22μF	0.22μF	0.22μF	0.22μF
C112/125	0.22μF	0.22μF	0.22μF	0.22μF
VR101/103	6.8k(B)	10k(B)	6.8k(B)	6.8k(B)
VR102/104	6.8k(B)	6.8k(B)	6.8k(B)	6.8k(B)
R315/342	18kΩ	6.8kΩ	18kΩ	6.8kΩ
R322/349	Jumper	100Ω	33Ω	180Ω
C306/324	0.082μF	0.056μF	0.056μF	0.082μF
C310/328	0.039μF	0.027μF	0.027μF	0.033μF
C314/332	0.022μF	0.015μF	0.012μF	0.0068μF
C315/333	0.056μF	0.022μF	0.027μF	0.022μF

A-2300S/A-3300S 4 TRACK

SERIAL NUMBER	Beginning with 1st Prod.	Beginning with Serial No.	Beginning with Serial No.
A-2300S(4T) A-3300S(4T)	#2731 #3301	#10481 #8881	#14881 #11881
Head			
Record	50666040	50664480	50663140
Playback	50669040	50664490	50663240
Blank Tape			
HIGH	SCOTCH 203	YTT-8003	YTT-8003
NORMAL	SCOTCH 150	SCOTCH 150	SCOTCH 150
Circuit REF.NO.			
* R108/127	220 Ω	330 Ω	330 Ω
R116/135	680k Ω	270k Ω	180k Ω
R117/136	120k Ω	120k Ω	33k Ω
R118/137	120k Ω	120k Ω	33k Ω
C111/124	0.22 μ F	0.22 μ F	1.0 μ F
C112/125	0.22 μ F	0.22 μ F	1.0 μ F
VR101/103	6.8k(B)	6.8k(B)	6.8k(B)
VR102/104	15k(B)	15k(B)	15k(B)
R315/342	18k Ω	6.8k Ω	6.8k Ω
R322/349	Jumper	150 Ω	150 Ω
C306/324	0.082 μ F	0.056 μ F	0.047 μ F
C310/328	0.039 μ F	0.027 μ F	0.027 μ F
C314/332	0.033 μ F	0.033 μ F	0.033 μ F
C315/333	0.047 μ F	0.033 μ F	0.033 μ F

* A-2300S only

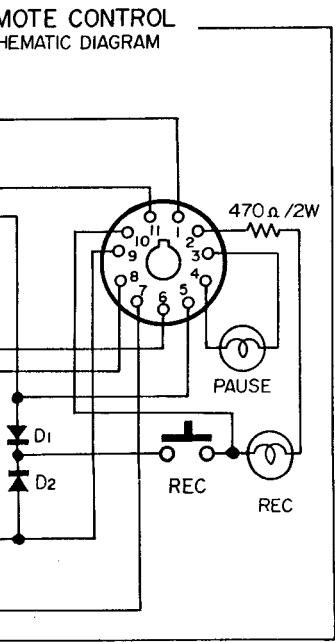
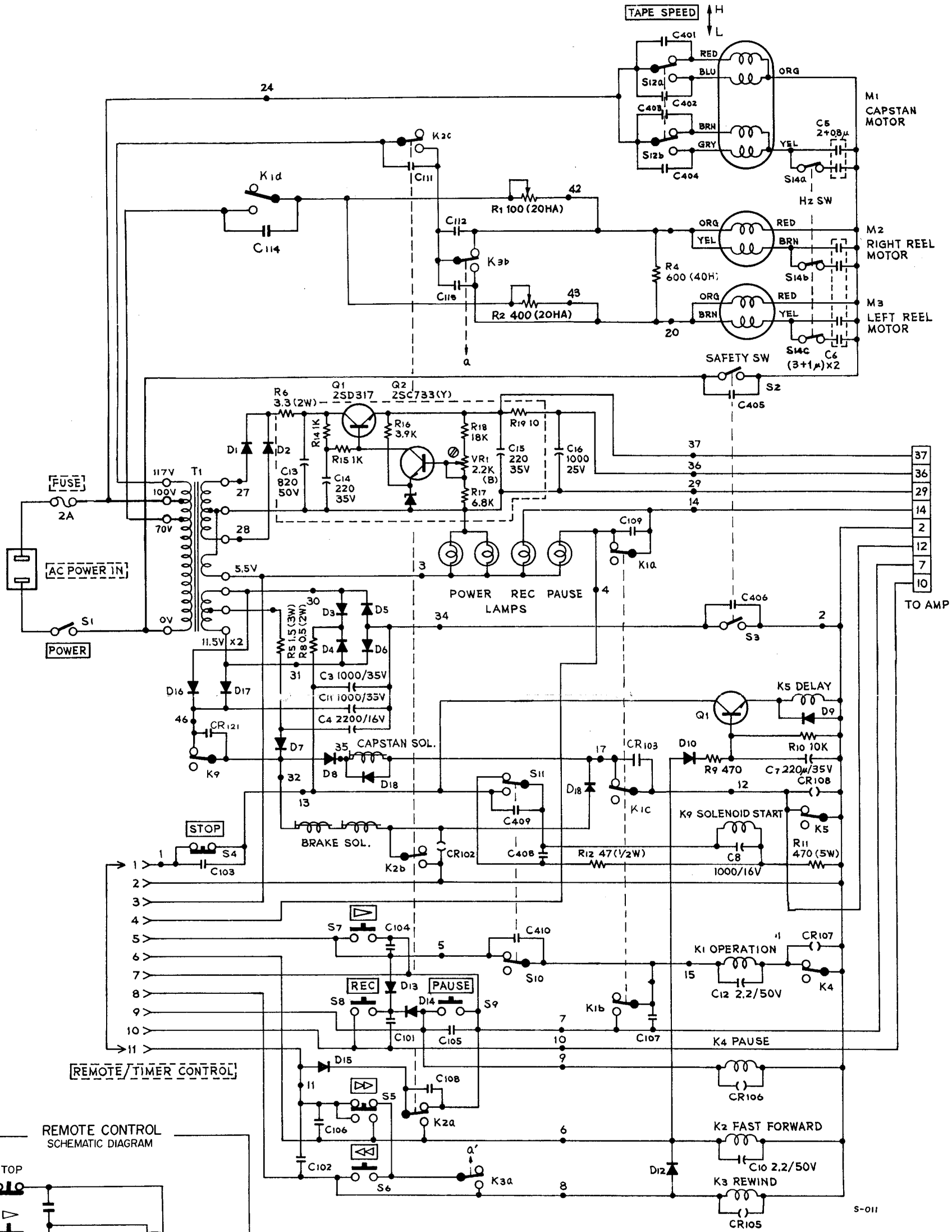

NOTES
 All relays shown not energized (stop mode)
 TAPE SPEED switch shown in the HIGH position
 Frequency conversion switch shown in the 50 Hz position
 [] On front panel
 [] On rear panel
 () Spark killer 0.1+120/400WV
 ○ Screwdriver adjustment
 —|— 0.1/400WV
 D1-6, D9-14, D16-17 : S1B01-02
 D7, D8 : S1B01-06

REVISION	DATE	CHANGE NO.
6		
5		
4		
3		
2		
1	E-605	

AFTER SERIAL NO. 9681
STEREO TAPE DECK
TAPE TRANSPORT
 MODEL NO. **A-2300S**
 SHEET NO. **TEAC CORPORATION**

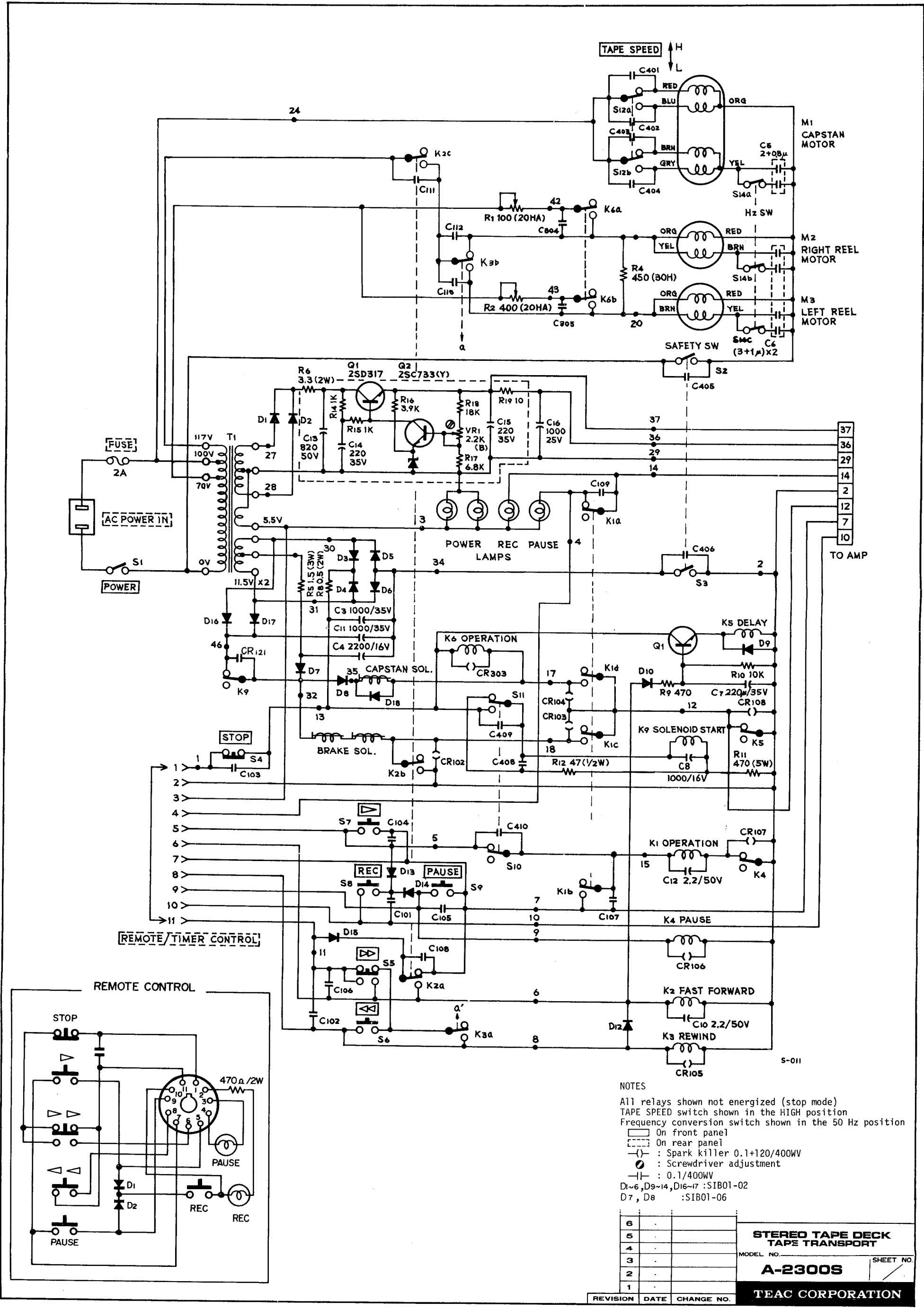

NOTES

All relays shown not energized (stop mode)
 TAPE SPEED switch shown in the HIGH position
 Frequency conversion switch shown in the 50 Hz position
 □ On front panel
 ▭ On rear panel
 (-) : Spark killer 0.1+120/400WV
 ⊕ : Screwdriver adjustment
 —|— : 0.1/400WV
 D1-6, D9-14, D16-17 : SIB01-02
 D7, D8 : SIB01-06

6		
5		
4		
3		
2		
1		
REVISION	DATE	CHANGE NO.

STEREO TAPE DECK
TAPE TRANSPORT
 MODEL NO. **A-2300S** SHEET NO. **1**
TEAC CORPORATION

MODEL	SERIAL NO.	CIRCUIT REF. NO.	DESCRIPTION
A-2300S(2T)	#2301	5602	R108/127
A-2300S(2T)	#15881	5602	R108/127
A-3300S(2T)	#3326	5602	R108/127
A-3300S(2T)	#12881	5602	R108/127
A-2300S(-#2721)	#3501	2202	R108/127
A-2300S(-#3501)	#1081	2202	R108/127
A-2300S(-#14881)	#14881	2202	R108/127
A-2300S(-#14881)	#14881	2202	R108/127

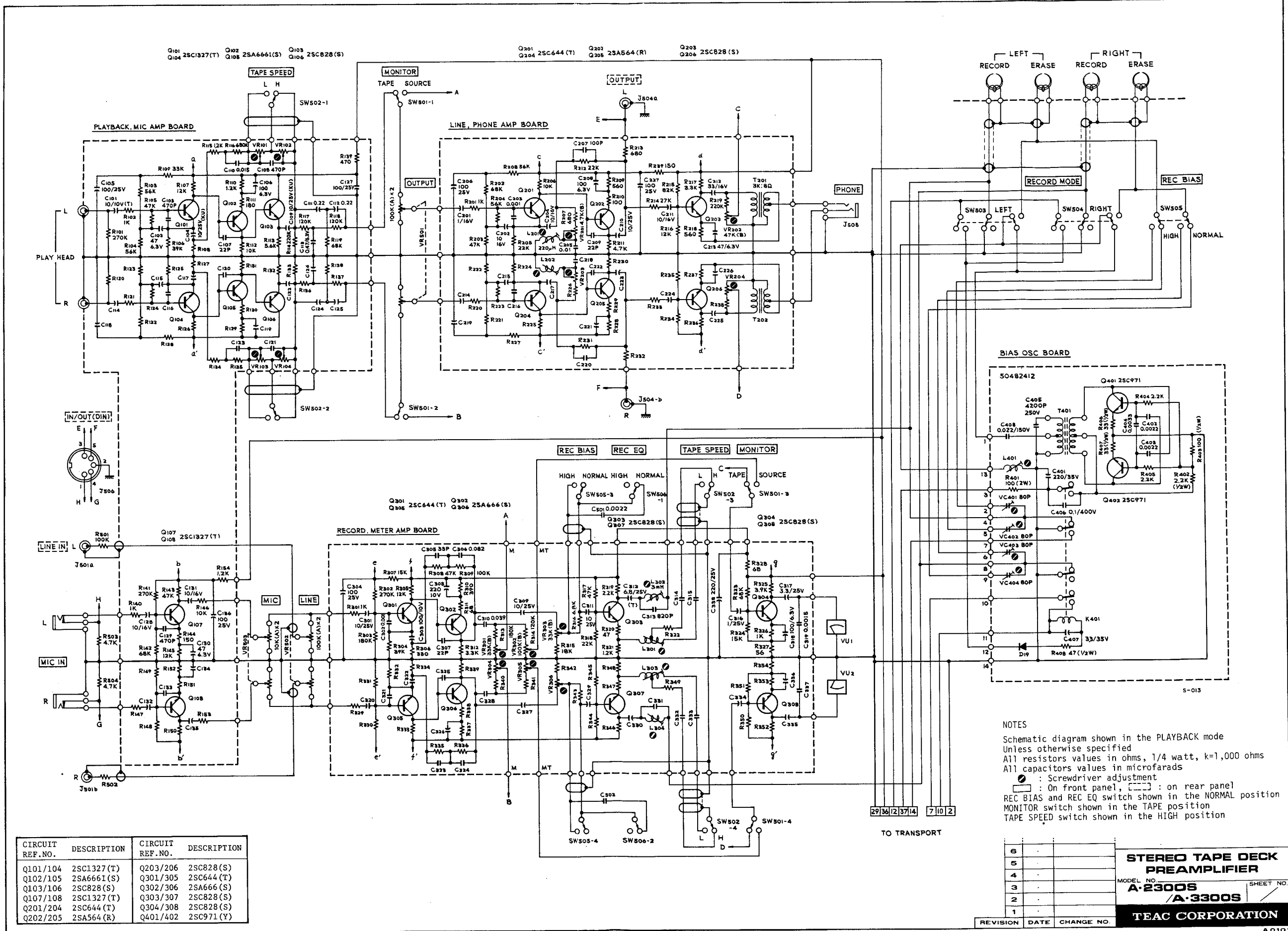

CIRCUIT REF. NO.	DESCRIPTION	CIRCUIT REF. NO.	DESCRIPTION
Q101/104	2SC1327(T)	Q203/206	2SC828(S)
Q102/105	2SA6661(S)	Q301/305	2SC644(T)
Q103/106	2SC828(S)	Q302/306	2SA666(S)
Q107/108	2SC1327(T)	Q303/307	2SC828(S)
Q201/204	2SC644(T)	Q304/308	2SC828(S)
Q202/205	2SA564(R)	Q401/402	2SC971(Y)

NOTES
 Schematic diagram shown in the PLAYBACK mode
 Unless otherwise specified
 All resistors values in ohms, 1/4 watt, k=1,000 ohms
 All capacitors values in microfarads
 Ⓢ : Screwdriver adjustment
 ☐ : On front panel, ☐ : on rear panel
 REC BIAS and REC EQ switch shown in the NORMAL position
 MONITOR switch shown in the TAPE position
 TAPE SPEED switch shown in the HIGH position

6		
5		
4		
3		
2		
1		

REVISION DATE CHANGE NO.

STEREO TAPE DECK PREAMPLIFIER
 MODEL NO. **A-2300S** SHEET NO. **A-3300S**
TEAC CORPORATION

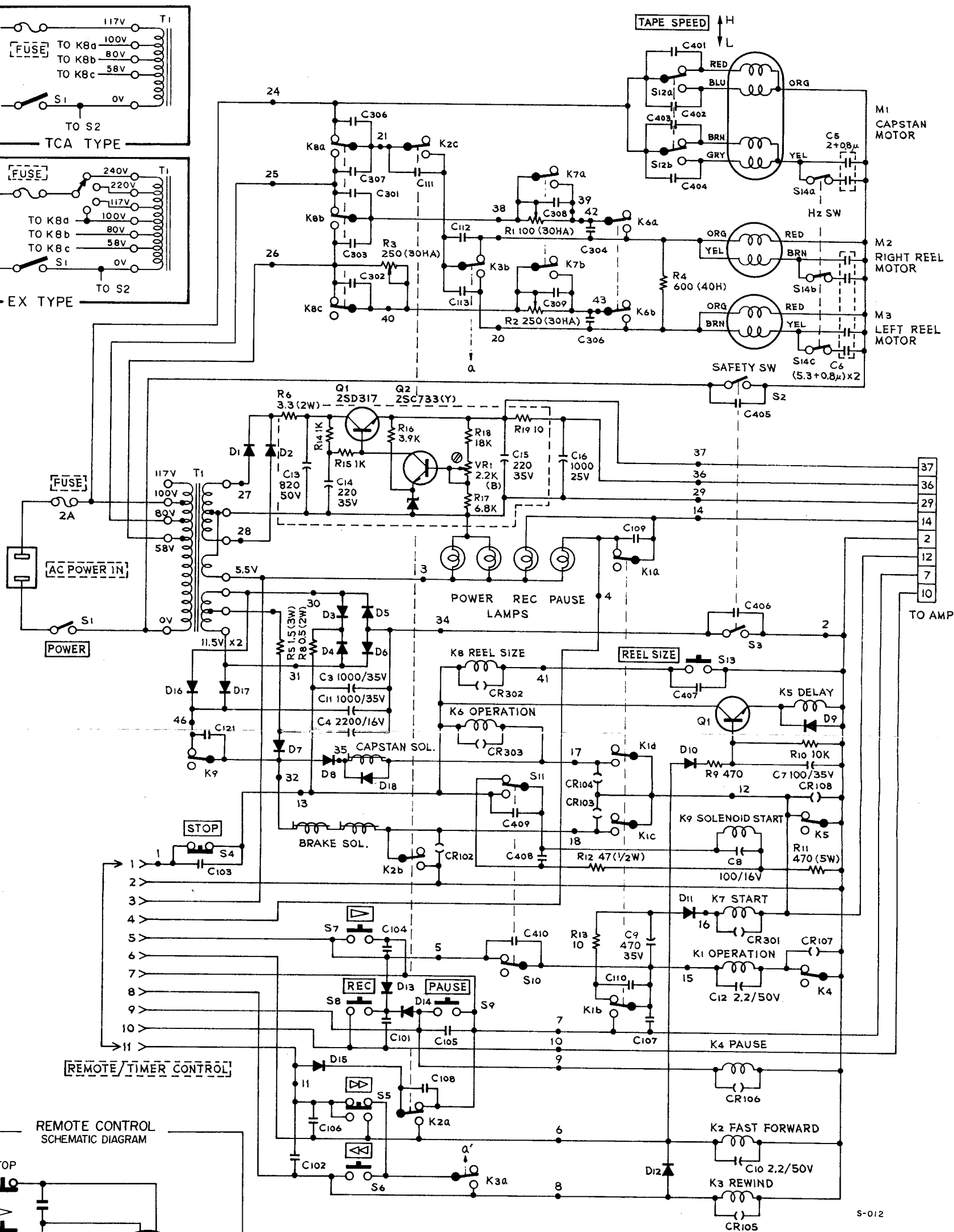
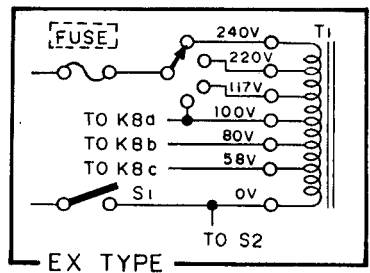
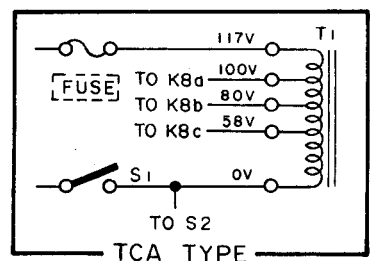

REMOTE/TIMER CONTROL

REMOTE CONTROL SCHEMATIC DIAGRAM

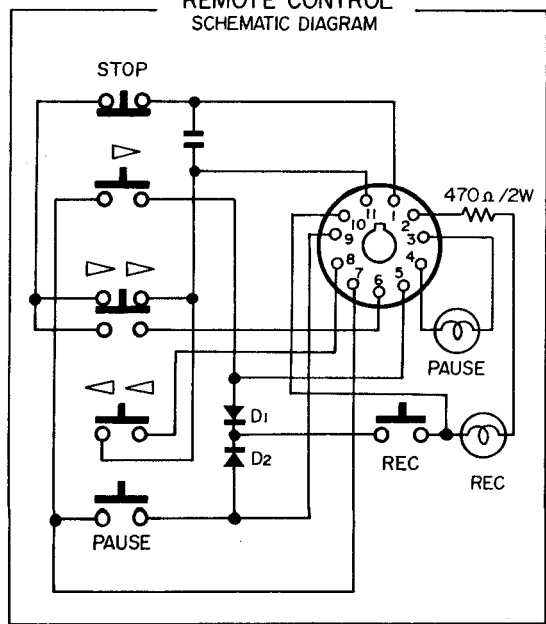

NOTES

- All relays shown not energized (stop mode)
- TAPE SPEED switch shown in the HIGH position
- Frequency conversion switch shown in the 50 Hz position
- On front panel
- ▭ On rear panel
- () : Spark killer 0.1+120/400W
- ⊙ : Screwdriver adjustment
- |— : 0.1/400W
- D1~6, D10~14, D16~18 : SIB01-02
- D7, D8 : SIB01-06

6		
5		
4		
3		
2		
1	E-605	
REVISION	DATE	CHANGE NO.

STEREO TAPE DECK
TAPE TRANSPORT
MODEL NO. _____ SHEET NO. _____
A-3300S
TEAC CORPORATION