

TEAC®

# SERVICE MANUAL

## A-3300SR A-2300SR

Stereo Tape Deck

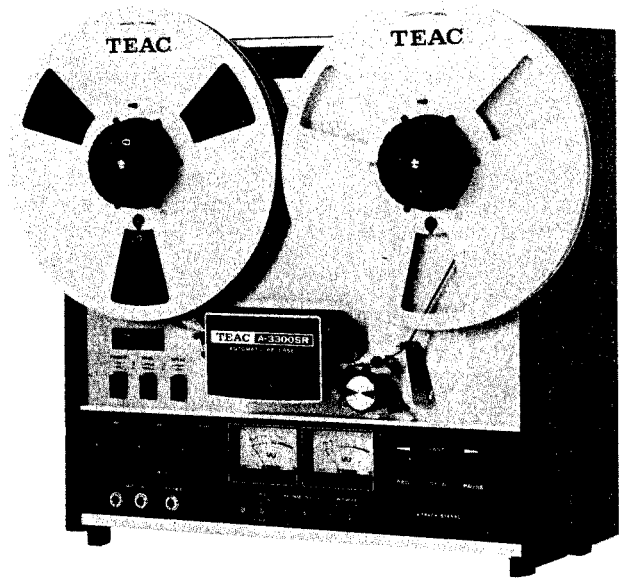

TEAC CORPORATION

51032220

# 1. GENERAL DESCRIPTION

The TEAC A-3300/A-2300 series tape decks have earned an enviable reputation for quality since their first introduction years ago. Over the years various design improvements have been incorporated in the basic model to keep these decks abreast of the advances in tape technology and to fulfill the needs of our growing range of knowledgeable customers.

The A-3300S/A-2300S and A-3300SX/A-2300SX followed, building on the tested and proven reliability of the original models and offering ever increasing versatility and user satisfaction.

Now TEAC introduces the new A-3300SR/A-2300SR which have the added capability of reverse playback together with several sophisticated circuit improvements to keep these new models at State-of-the-art reliability.

The basic design of the A-3300SR/A-2300SR is highly similar to that of the A-3300SX/A-2300SX, therefore, information in this manual may be applied to the A-3300SX/A-2300SX also.

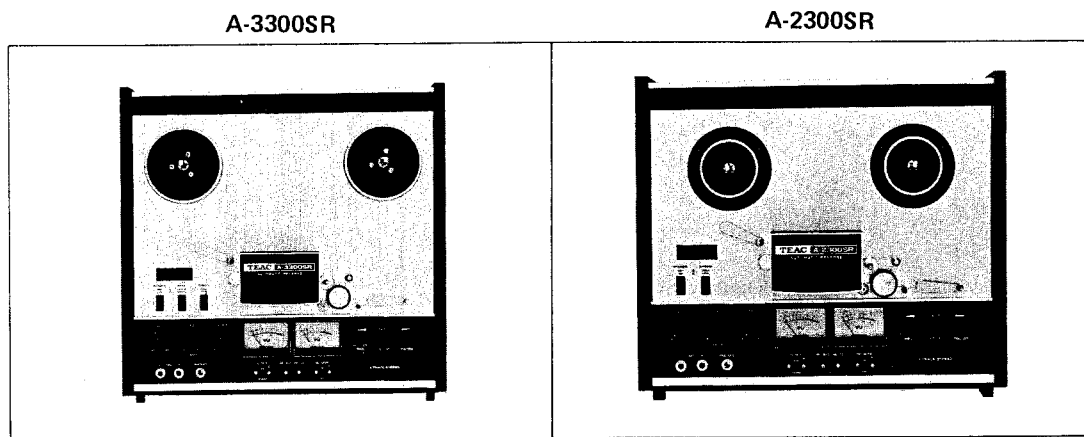

## — TABLE OF CONTENTS —

1. GENERAL DESCRIPTION .....	3
2. SPECIFICATIONS AND SERVICE DATA .....	4
3. TOOLS FOR TESTING AND MAINTENANCE ...	6
4. PARTIAL DIS-ASSEMBLY .....	7
5. TAPE TRANSPORT PARTS LOCATION .....	9
6. HEAD REPLACEMENT AND ALIGNMENT .....	10
— MECHANICAL —	
7. MEASUREMENT AND ADJUSTMENT .....	11
— MECHANICAL —	
8. MEASUREMENT AND ADJUSTMENT .....	14
— ELECTRICAL —	
9. SERVICING AND MAINTENANCE .....	21
10. SIMPLIFIED SCHEMATIC WITH LEVEL INDICATIONS .....	22

## 2. SPECIFICATIONS AND SERVICE DATA

### 2-1 A-3300SR

Track System	1/4 track 2 channel stereophonic 1/4 track 1 channel monophonic
Heads	Three; Erase, Record and Forward/Reverse Playback
Reel Size	10-1/2" and 7"
Tape Speed	7-1/2 ips and 3-3/4 ips
Motors	1 Dual-Speed Hysteresis Synchronous Capstan Motor 2 Eddy Current Induction Reel Motors
Inputs (Level and Impedance)	MIC: Specified; -60 dB (0.774 mV)/10k ohms Minimum; -70 dB (0.244 mV) LINE: Specified; -8 dB (308 mV)/50k ohms Minimum; -18 dB (97 mV)
Outputs (Level and Load Impedance)	HEADPHONE: -24 dB (49 mV)/8 ohms LINE: Specified; -8 dB (308 mV)/10k ohms Maximum; -2 dB (615 mV)
Playback Equalization	7-1/2 ips: NAB 3180 $\mu$ s, 50 $\mu$ s 3-3/4 ips: NAB 3180 $\mu$ s, 90 $\mu$ s
Bias Frequency	100k Hz ( $\pm$ 5k Hz, push-pull oscillator)
Power Requirement	100, 117, 220, 240 V AC 50/60 Hz (General Export Model) 117 V AC 60 Hz (U.S.A. and Canada Model)
Power Consumption	143 W
Weight	21 kg (46 lbs) net
Dimensions (WHD)	440 x 440 x 210 mm (17-5/16" x 17-5/16" x 8-1/4")

### 2-2 SERVICE DATA -MECHANICAL-

Tape Speed Deviation and Drift	3,000 Hz $\pm$ 30 Hz, within 15 Hz
Wow and Flutter	Playback: Both Direction, 0.18% (RMS) at 7-1/2 ips 0.20% (RMS) at 3-3/4 ips Overall: 0.20% (RMS) at 7-1/2 ips 0.25% (RMS) at 3-3/4 ips
Pinch Roller Pressure	2.1 kg (4.6 lbs)
Reel Torque	

DIRECTION	REEL SIZE	TAKE-UP VALUES	BACK TENSION VALUES
FWD	LARGE	790 to 870 g-cm (11 to 12 oz-inch)	280 to 360 g-cm (4 to 5 oz-inch)
	SMALL	370 to 410 g-cm (5 to 6 oz-inch)	175 to 215 g-cm (2.4 to 3 oz-inch)
REV	LARGE	1000 to 1100 g-cm (14 to 15 oz-inch)	320 to 400 g-cm (4.5 to 5.6 oz-inch)
	SMALL	500 to 550 g-cm (7 to 8 oz-inch)	185 to 225 g-cm (2.6 to 3 oz-inch)

Brake Torque	1,600 to 2,000 g-cm (22 to 28 oz-inch)
F.F./REW Time	140 seconds for 1,800 foot tape

Refer to Section 2-5 for Electrical Service Data applicable to both models.

**NOTE:** As a result of continuing change and improvements during the production run, minor differences may be found between early and later machines.  
Value of "dB" in this manual refer to 0 dB = 0.775 V.

## 2-3 A-2300SR

Track System	1/4 track 2 channel stereophonic 1/4 track 1 channel monophonic
Heads	Three; Erase, Record and Forward/Reverse Playback
Reel Size	7"
Tape Speed	7-1/2 ips and 3-3/4 ips
Motors	1 Dual-Speed Hysteresis Synchronous Capstan motor 2 Eddy Current Induction reel motors
Inputs (Level and Impedance)	MIC: Specified; -60 dB (0.774 mV)/10k ohms Minimum; -70 dB (0.244 mV) LINE: Specified; -8 dB (308 mV)/50k ohms Minimum; -18 dB (97 mV)
Outputs (Level and Load Impedance)	HEADPHONE: -24 dB (49 mV)/8 ohms LINE: Specified; -8 dB (308 mV)/10k ohms Maximum; -2 dB (615 mV)
Playback Equalization	7-1/2 ips: NAB 3180 $\mu$ s, 50 $\mu$ s 3-3/4 ips: NAB 3180 $\mu$ s, 90 $\mu$ s
Bias Frequency	100k Hz ( $\pm$ 5k Hz, push-pull oscillator)
Power Requirement	100, 117, 220, 240 V AC 50/60 Hz (General Export Model) 117 V AC 60 Hz (U.S.A. and Canada Model)
Power Consumption	120 W
Weight	19 kg (42 lbs) net
Dimensions (WHD)	440 x 392 x 210 mm (17-5/16" x 15-7/16" x 8-1/4")

## 2-4 SERVICE DATA —MECHANICAL—

Tape Speed Deviation and Drift	3,000 $\pm$ 30 Hz, within 15 Hz
Wow and Flutter	Playback: 0.18% (RMS) at 7-1/2 ips 0.20% (RMS) at 3-3/4 ips Overall: 0.20% (RMS) at 7-1/2 ips 0.25% (RMS) at 3-3/4 ips
Pinch Roller Pressure	2.1 kg (4.6 lbs)

Reel Torque

DIRECTION	TAKE-UP VALUES	BACK TENSION VALUES
FWD	370 to 410 g-cm (5 to 5.6 oz-inch)	175 to 215 g-cm (2.4 to 3 oz-inch)
REV	500 to 540 g-cm (7 to 8 oz-inch)	185 to 225 g-cm (2.6 to 3 oz-inch)

Brake Torque	800 to 1,200 g-cm (11 to 17 oz-inch)
Fast Forward/Rewind Time	140 seconds for 1,800 foot tape

## 2-5 SERVICE DATA —ELECTRICAL— (both models)

Frequency Response	Refer to Frequency Response Limits chart in this manual
Signal-to-noise Ratio	Overall: 47 dB or higher at 7-1/2 ips 45 dB or higher at 3-3/4 ips
Erase Efficiency	68 dB or more at 1k Hz (Measured with input 10 dB higher than the specified input level)
Crosstalk Rejection	40 dB or more, adjacent track at 125 Hz 50 dB or more, channel to channel at 1k Hz
Total Harmonic Distortion	Overall: 1.0% or less at 1k Hz signal at 0 VU

## DIMENSIONS

**A-3300SR**

**A-2300SR**

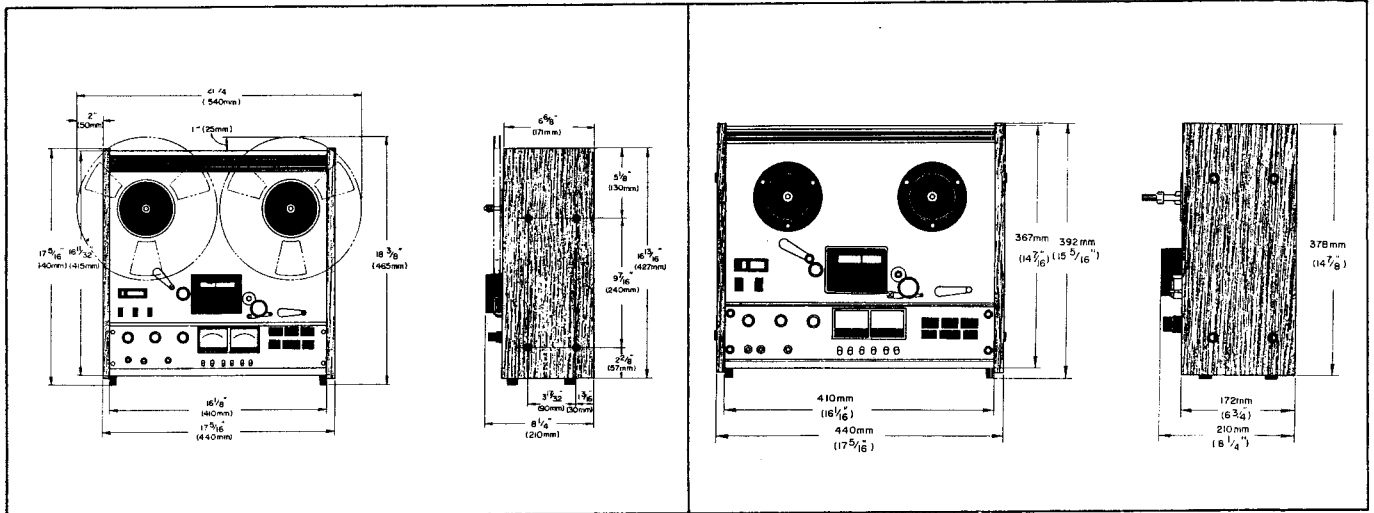

## 3. TOOLS FOR TESTING AND MAINTENANCE

A minimum of the following tools and test instruments are required for measuring and adjusting to obtain optimum performance. Regular maintenance tools will be adequate for those not listed here. If any test instrument listed here is not available, a close equivalent can be used.

WOW AND FLUTTER METER . . . . .	Meguro Denpa Sokki K.K., Model MK-668C or D & R Co., Model FL-4B
AC VTVM . . . . .	Hewlett-Packard Co., Model 400E (0.1 mV – 300V)
DIGITAL FREQUENCY COUNTER . . . . .	Range; 10 Hz – 100 kHz
BAND-PASS FILTER . . . . .	1 kHz narrow band-pass type
OSCILLOSCOPE . . . . .	General Purpose
AF OSCILLATOR . . . . .	10 Hz – 100 kHz
ATTENUATOR . . . . .	General Purpose
DISTORTION ANALYZER . . . . .	Basic Freq. 400 Hz/1 kHz
TOOLS . . . . .	Spring scale; 0–4 kg (0–8 lbs) 0–1 kg (0–2.2 lbs)
	Hex head Allen Wrench,
	Plastic alignment tool,
	Load resistor non-inductive type 8 ohm/1 W
HEAD DEMAGNETIZER . . . . .	TEAC E-3 or equivalent
TEAC TEST TAPE . . . . .	YTT-1002 (3-3/4 ips), YTT-1003 (7-1/2 ips) for Playback Alignment test, YTT-8013 and YTT-8023 for Recording test, YTT-2002 (3-3/4 ips), YTT-2003 (7-1/2 ips) for Tape Speed and Wow/Flutter test
TEAC EMPTY REEL . . . . .	RE-702 (2.5" dia. hub), RE-701 (4" dia. hub)

## 4. PARTIAL DIS-ASSEMBLY

### 4-1 REMOVING WOODEN SIDES AND REAR PANEL

See illustration for complete dis-assembly instructions. Most amplifier checks and adjustments can be made from the bottom with the (bottom) panel removed.

These adjustments should be performed by experienced technicians, and then only when going through the complete test and check procedures on the unit which is being tested.

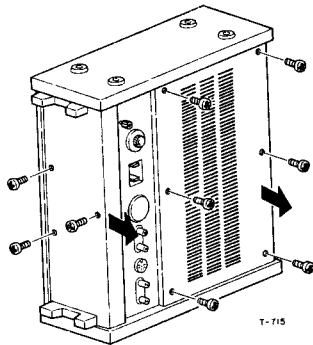
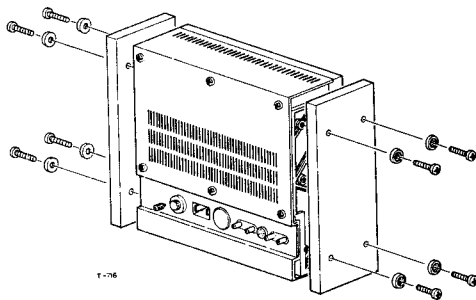

Fig. 4-1 Removing Wooden Sides and Rear and Bottom Panels

### 4-2 HEAD ASSEMBLY REMOVAL

To change the head assembly as a unit,

1. Note the positions of the wires on the circuit board.
2. Unsolder the wires.
3. Remove the 2 mounting screws, replace the assembly.
4. Solder the wires of the new assembly in exactly the same positions.

**NOTE:** See page 10, HEAD REPLACEMENT AND ALIGNMENT Section for more detailed explanation.

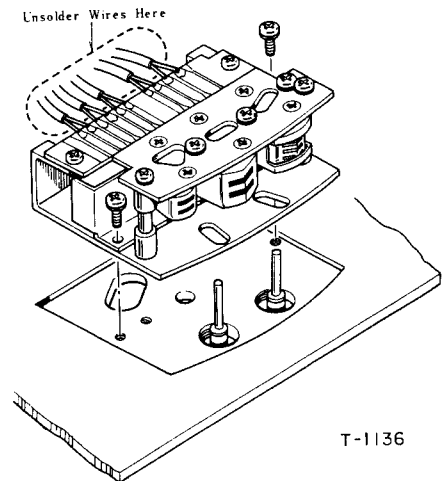

Fig. 4-2 Head Ass'y Removal

### 4-3 REMOVAL OF CAPSTAN MOTOR

1. Remove the 3 screws (a) holding the capstan motor Plate.
2. Unsolder the 6 wires connecting the capstan motor.
3. Remove the 4 screws holding the capstan motor to the motor plate. Watch for the Rubber Cushions.
4. Loosen the 2 set screws (hex head) in pulley and lift off pulley. Loosen 2 set screws in fan and remove fan.

**NOTE:** USA, CANADA versions of the A-3300SR/A-2300SR have a different pulley than that shown and have no Frequency Selector switch. See page 13, Section VOLTAGE AND FREQUENCY CONVERSION.

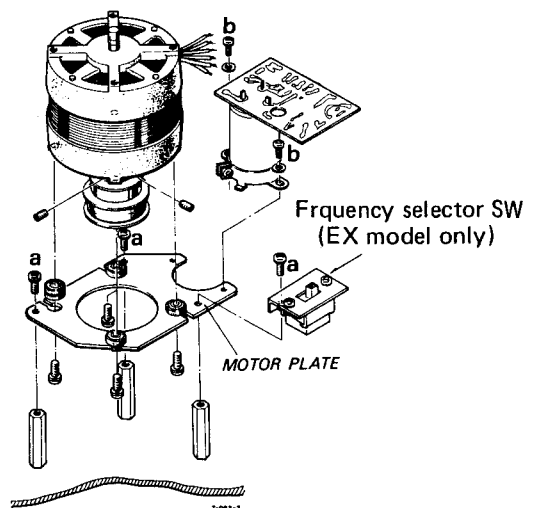

Fig. 4-3 Capstan Motor Removal

#### 4-4 REMOVAL OF CAPSTAN ASSEMBLY

1. Unscrew dust cap (front panel).
2. Remove 2 screws from rear bracket. Allow bracket to drop toward floor of case.
3. Remove capstan belt.
4. Loosen 2 screws in flywheel. Remove flywheel.
5. Remove 3 screws in capstan ass'y.
6. Gently move capstan ass'y up and down until it slides out of panel.

**NOTE:** When replacing flywheel, position flywheel on capstan ass'y shaft so that end of shaft protrudes slightly from rear of flywheel. A clearance of approx. 0.01" must be maintained between the end of the capstan shaft and the rear bracket.

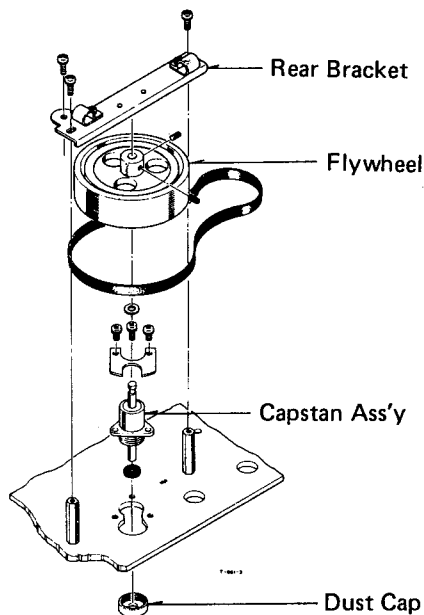
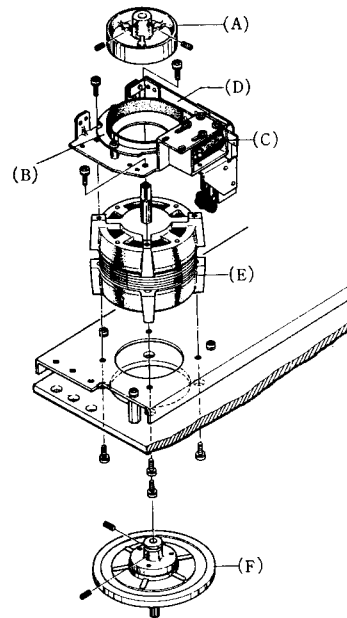

Fig. 4-4 Capstan Ass'y Removal

#### 4-5 REMOVAL OF REEL MOTOR

1. Disconnect the 4 motor wires from terminals and release wire harness straps.
2. Loosen 2 set screws (hex head) in Brake drum(A) and 2 in the Reel Turntable assembly(F). Lift off these parts.
3. Remove 4 screws securing the Brake Assembly(D) to the motor. Carefully lift off the Brake Retainer(B). Do not remove wires connected to the brake solenoid(C) or micro switch.
4. Remove 4 screws securing Reel Motor(E) to chassis through the front panel.

#### A-3300SR



#### A-2300SR

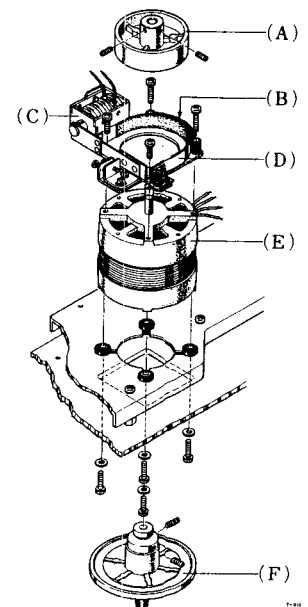

Fig. 4-5 Reel Motors Removal

#### 4-6 REMOVAL OF TENSION ARMS LEFT AND RIGHT

See illustration for complete dis-assembly instructions.

**IMPORTANT:** After re-assembly check clearance to ascertain that arm moves freely and is not binding.

**CAUTION:** Do not over-tighten screws holding micro-switches.

Insulating spacer and micro-switches are easily broken by excess pressure.

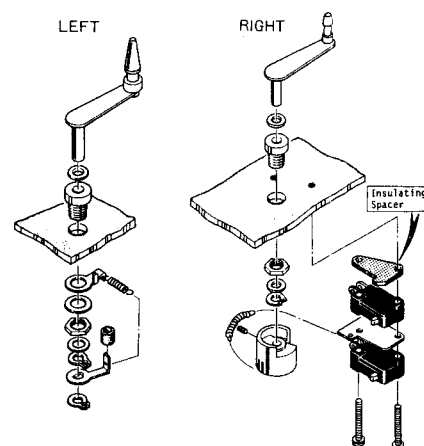
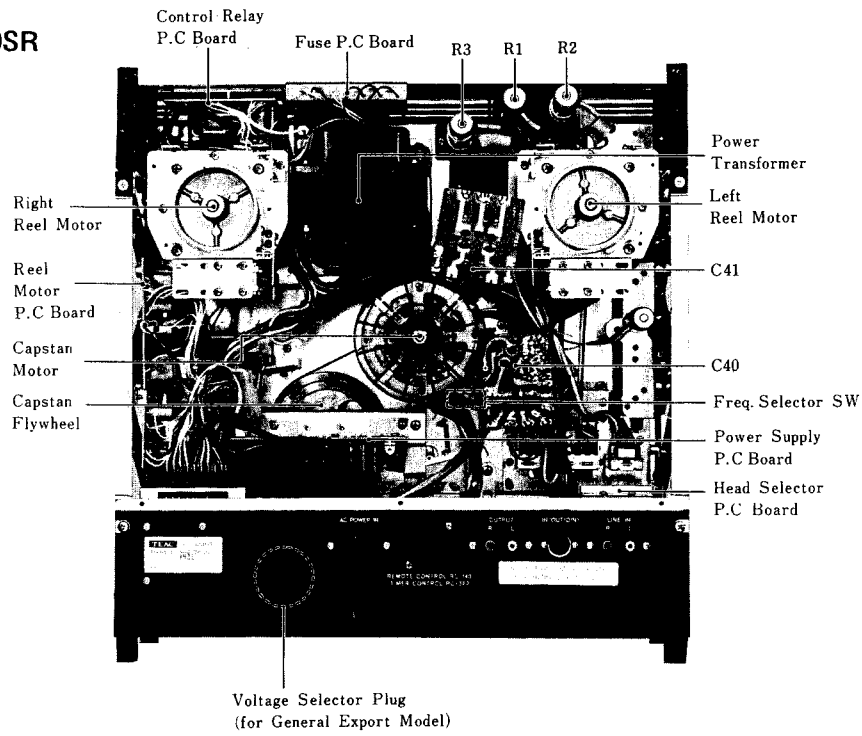

Fig. 4-6 Tension Arms Removal

# 5. TAPE TRANSPORT PARTS LOCATION

## REAR VIEW

A-3300SR



A-2300SR

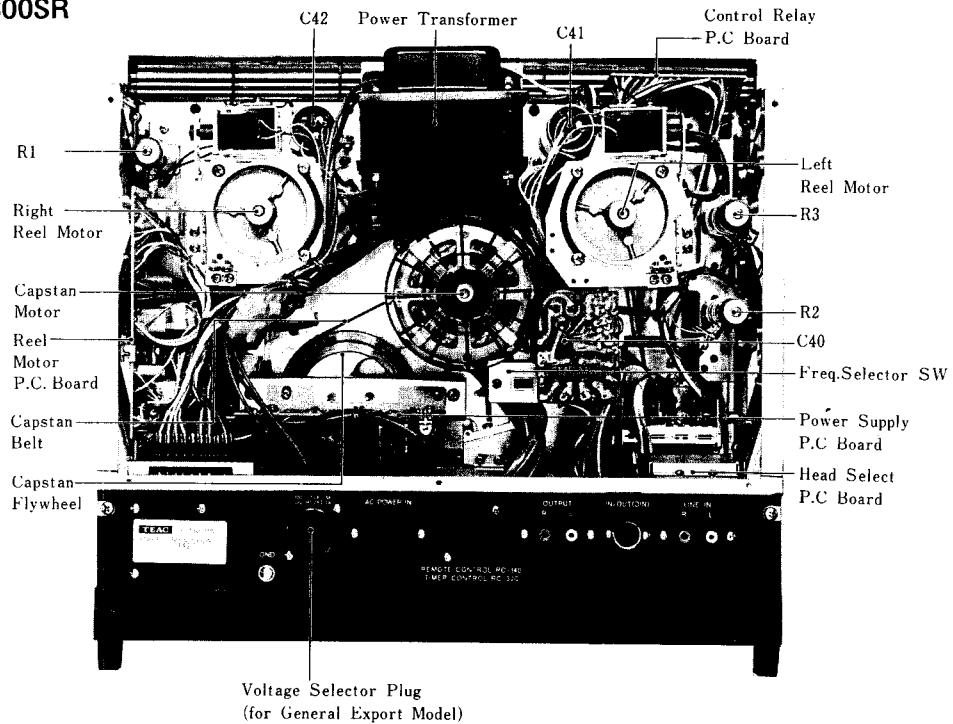

**NOTE:** Refer to page 12 for the TORQUE MEASUREMENT procedure. For ordering parts, refer to the exploded view in the PARTS LIST. An accompanying listing provides the correct parts numbers.



## 6. HEAD REPLACEMENT AND ALIGNMENT

### — MECHANICAL —

#### 6-1 HEAD REPLACEMENT AND WIRING

To replace a single head a special 2 mm nut driver is required. Remove the 2 nuts (A) on the defective head through the access hole provided. This releases the head from the mounting plate. Note the position of the wires on the circuit board. Connect the new head in the same manner. Replace the nuts securing the new head to the plate. Perform head alignment before operation.

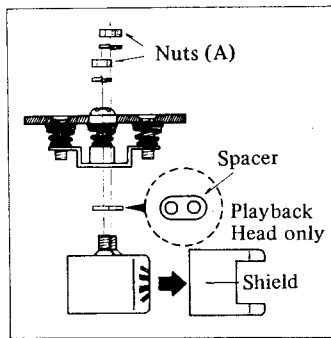

Fig. 6-1 Head Replacement

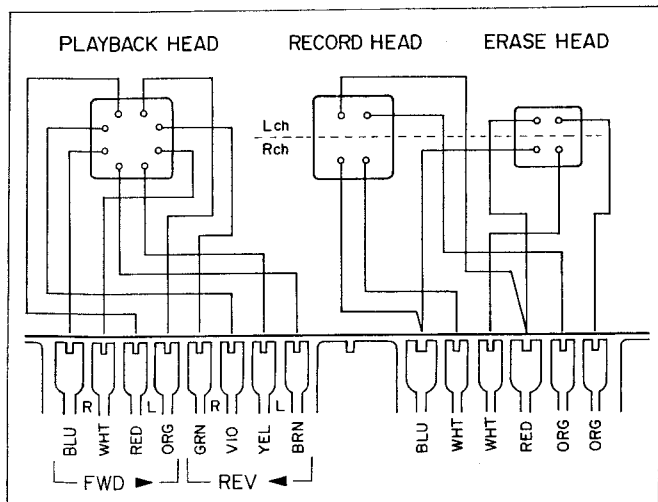

Fig. 6-2 Head Wiring —Rear View—

#### 6-2 HEAD ADJ. SCREWS AND NUTS

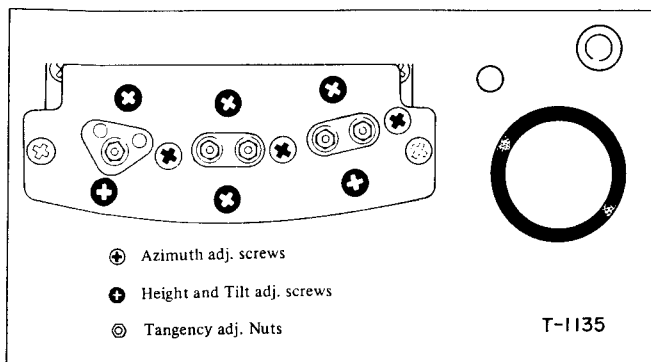

Fig. 6-3 Head Adjustment Screws and Nuts

#### 6-3 VISUAL HEAD ALIGNMENT

Since head alignment critically affects the frequency response on both playback and recording, the head alignment should be done carefully. The head can be adjusted in TILT, TANGENCY, HEIGHT and AZIMUTH.

For head alignment, perform the following coarse adjustments first. Then fine alignment should be accomplished electrically while playing back the Test Tape.

##### Coarse Adjustment;

Without Tape

TILT . . . . . By Height and Tilt screws

This alignment is performed by viewing from the side without tape threaded.

Check that the head surface is parallel to the tape guide surface.

With Tape

TANGENCY . . . . . By Head mounting Nuts

Loosen the head mounting nuts. Adjust the head so that the vertical alignment of the head gap is perpendicular to the surface of the tape, then tighten the head mounting Nuts.

HEIGHT . . . . . By Height and Tilt screws

This alignment is checked visually by looking at the position of the head.

The head core for track-1 (inner core) should be even with the inner edge of the tape.

AZIMUTH . . . . . By Azimuth adj. Screw

Adjust the azimuth adj. screw so that the gap of the head is perpendicular to the tape travel.

**NOTE:** After this coarse adjustment is made, the adj. screws and the Head mounting nuts should be realigned according to electrical head alignment paragraph which follows in this Service Manual.

#### 7-4 MIS-ALIGNMENT OF THE HEADS

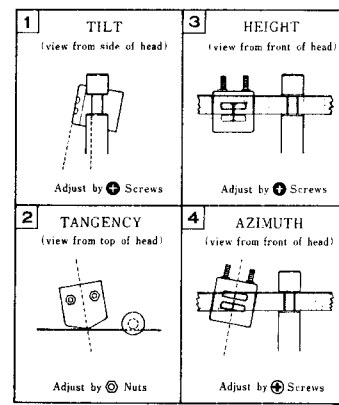

Fig. 6-4 Head Mis-Alignment — Examples —

## 7. MEASUREMENT AND ADJUSTMENT

### — MECHANICAL —

#### 7-1 PINCH ROLLER PRESSURE

**NOTE:** Pinch roller pressure is supplied by the pinch roller spring arm and it is most important that the solenoid plunger be fully bottomed before taking pressure measurement.

1. Load tape or block the shut-off arm in the ON position.
2. Attach a suitable spring scale to the pinch roller shaft.
3. Place the unit in the PLAY mode (▶), and holding the spring scale as illustrated, slowly draw it away from the pinch roller.
4. Do not allow the string to rub against the pinch roller.
5. Note the reading on the spring scale at the instant the pinch roller stops rotating.
6. The scale should indicate 2.0 to 2.2 kg (4.4 to 5.0 lbs.)
7. If adjustment is necessary, loosen the 3 screws on the capstan solenoid and position the solenoid for optimum pressure.
8. Adjust solenoid-limit position so that the gap between capstan shaft and pinch roller is approx. 7mm when solenoid is not actuated. Also make sure pinch roller shaft does not contact spring arm (B). Limit is adjusted by loosening the mounting screw (A), then sliding limit until proper position is obtained.

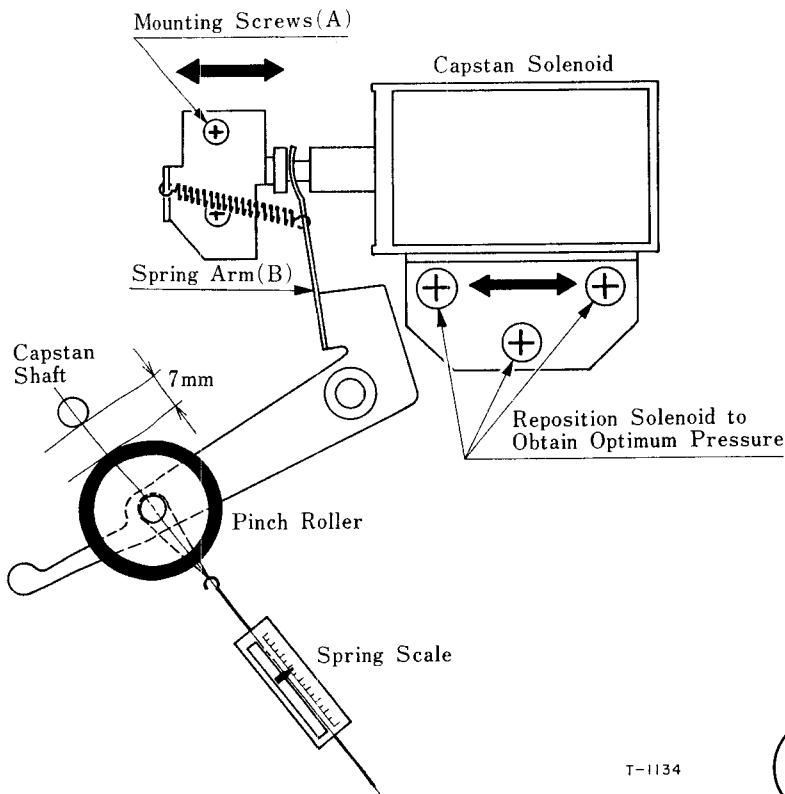

Fig. 7-1 Pressure Measurement and Adj. Locations

#### 7-2 BRAKE TORQUE

The brake torque is actuated mechanically. Pressure is set by the variable spring force. While making these measurements and adjustments, be careful not to bend the brake bands. As brake torque will change with cleaning, brake drums should be cleaned only when absolutely necessary. If cleaning is required, use TEAC cleaner TZ-261A. After cleaning, operate the brakes by depressing the play and STOP buttons several times to completely dry out the brakes before performing the following procedure.

**NOTE:** Brake adjustments are made with NO power connected to the equipment.

1. Place an empty large hub reel on the left reel table, and fasten one end of a 30" length of string to the reel anchor.
2. Wind several turns of string counterclockwise around the hub and attach a suitable spring scale to the free end of the string and pull on scale until reel begins to turn.
3. Take a reading only when the reel is in steady motion since the force required to overcome static friction will produce a false, excessively high initial reading.
4. The reading (Calculated value) should be 1800 g-cm  $\pm$ 200 g-cm (22 to 28 oz-in). 1000 g-cm  $\pm$ 200 g-cm (11 to 17 oz-inch) for A-2300 SR
5. If adjustment is required, loosen the 3 screws shown and position the brake for optimum torque.
6. The adjustment of the right brake is the same, with the exception that rotations are clockwise. (wind string CLOCKWISE around reel hub)
7. See note at the top of page 12 for explanation of torque measurements.

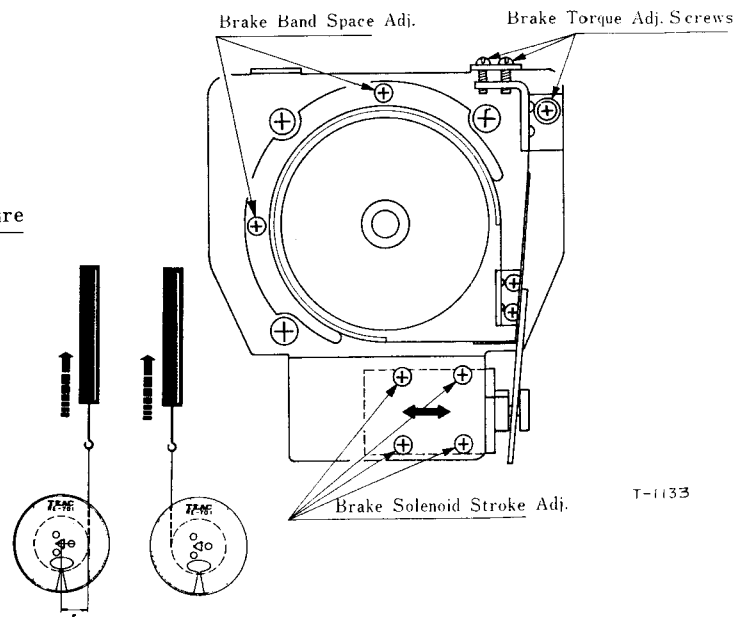

Fig. 7-2 Torque Measurement and Adjustment Location

# TORQUE MEASUREMENT PROCEDURE

**NOTE:** The following torque measurements should be made with a spring scale that is calibrated to read Torque in gram-cm. for a 7" reel with a small reel hub. If the spring scale you are using is calibrated to read Force or Weight in grams the Torque must be calculated using the Formula:

$$\text{Torque (in gm}\cdot\text{cm or oz}\cdot\text{in)} = \frac{\text{Weight or Force (in gr. or oz.)} \times \text{radius of hub (in cm or inches)}}{1}$$

If you are using a reel with other than the standard 2.5" or 6.0 cm (approx.) diameter hub, the Torque must be calculated using the same formula and substituting the actual radius and Weight or Force reading.

All Torque and Tension measurements must be made with the automatic shut-off switch (right tension arm) held in the ON position.

Brake Torque Measurement should be made using large hub reel with a hub diameter of 4" or 10.2 cm.

Fig. 7-3 Torque Measurement and Formula

## 7-3 TAKE-UP TORQUE

1. Place the empty reel on the right reel table and attach spring scale.
2. Place the deck in the Play mode.
3. Allow the rotation of the reel to slowly draw the scale toward the hub.
4. Hold the spring scale with enough force to allow a steady reading.
5. Repeat the procedure for the Reverse (◀) Play.
6. **The reading or calculated value should be approx.:**  
SMALL size value is for reference only

DIRECTION	REEL SIZE	TAKE-UP VALUES
FWD	LARGE	790 to 870 g-cm (11 to 12 oz-inch)
	SMALL	370 to 410 g-cm (5 to 6 oz-inch)
REV	LARGE	1000 to 1100 g-cm (14 to 15 oz-inch)
	SMALL	500 to 550 g-cm (7 to 8 oz-inch)

A-3300 SR

DIRECTION	TAKE-UP VALUES
FWD	370 to 410 g-cm (5 to 5.7 oz-inch)
REV	500 to 540 g-cm (7 to 8 oz-inch)

A-2300SR.

## 7-4 BACK TENSION

1. Place an empty 7" reel with small hub on the left reel table and fasten one end of a 30" length of string to the reel anchor.
2. Wind several turns of string counter-clockwise around the hub. Attach spring scale to string.
3. Place the deck in the Play mode.

4. Pull the scale away from the reel against the motor torque with a steady, smooth motion.
5. Note the scale reading while it is in steady motion.  
(The string must not rub the reel flanges)
6. Repeat the procedure for the Reverse (◀) Play.
7. **The reading or calculated value should be approx.:**  
SMALL size value is for reference only

A-3300 SR

DIRECTION	REEL SIZE	BACK TENSION VALUES
FWD	LARGE	280 to 360 g-cm (4 to 5 oz-inch)
	SMALL	175 to 215 g-cm (2.4 to 3 oz-inch)
REV	LARGE	320 to 400 g-cm (4.5 to 5.6 oz-inch)
	SMALL	185 to 225 g-cm (2.6 to 3 oz-inch)

A-2300SR

DIRECTION	BACK TENSION VALUES
FWD	175 to 215 g-cm (2.5 to 3 oz-inch)
REV	185 to 225 g-cm (2.6 to 3 oz-inch)

## Adjustment Location

If necessary, adjust slider of the resistors until you have the correct scale reading for optimum torque. Refer to adj. location below.

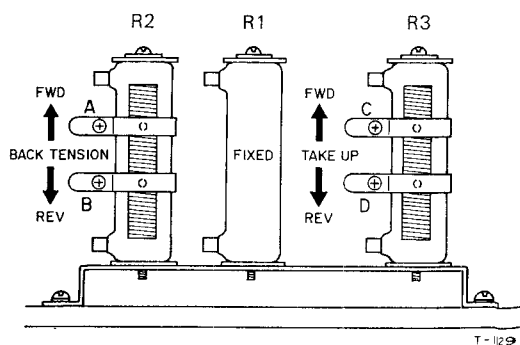

A-3300SR

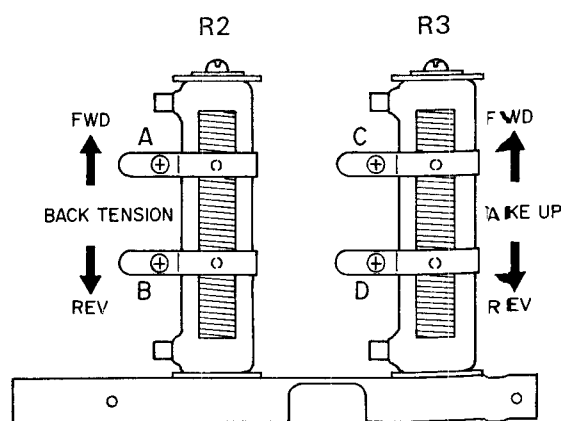

A-2300SR

Fig. 7-4 Adjustment Location

## 7-5 TAPE SPEED CHECK

The tape speed should be measured using TEAC flutter free tape, Model YTT-2003 (7-1/2 ips) and YTT-2002 (3-3/4 ips). These tapes contain a highly accurate 3,000 Hz tone. Connect a digital frequency counter to either line OUTPUT jack. See Fig. 7-5. The indicated frequency should be 3,000 Hz ( $\pm 30$  Hz) for all speeds during playback of the tape.

## 7-6 WOW AND FLUTTER CHECK

**NOTE:** Before performing this measurement, clean the heads and Tape run guides, also check pinch roller pressure, etc.  
Use new Test Tape if possible for following checks.  
Values obtained with different standards of equipment cannot be compared.

### PLAYBACK

1. Connect Test equipment to the deck as shown Fig. 7-5. (Except oscillator).
2. Load TEAC YTT-2003 (for 7-1/2 ips) or YTT-2002 (for 3-3/4 ips) and playback tape.
3. Read the indication on the Wow and Flutter meter.
4. The Wow and Flutter should be:  
0.18% (RMS) or less for 7-1/2 ips  
0.20% (RMS) or less for 3-3/4 ips

### OVERALL

1. Connect Test equipment to the deck as shown Fig. 7-5.
2. Load TEAC YTT-8013 (blank tape) Test Tape on the deck and Record a 3,000 Hz input signal.
3. Rewind and playback the recorded signal.
4. The reading on the Meter should be  
0.20% (RMS) or less for 7-1/2 ips  
0.25% (RMS) or less for 3-3/4 ips

**NOTE:** These figures apply to any tape position (such as full take-up reel, full supply reel or about mid-point). Also examine the tape counter ass'y for evenness of operation.

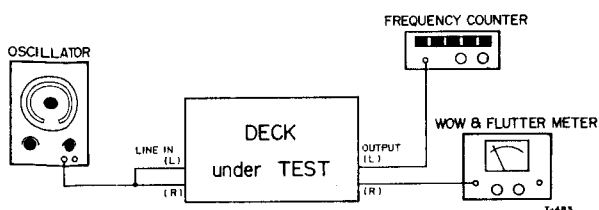

Fig. 7-5 Test Connections for Wow/Flutter and Tape Speed Test

## 7-7 VOLTAGE AND FREQUENCY CONVERSION (only General Export model)

This deck is adjusted to operate on an electric power source of the voltage and frequency specified on the reel tag and packing carton. If it is necessary to change the frequency or voltage requirements of this deck to match your area, use the following procedures.

Always disconnect Power Line Cord before making these changes.

### Frequency Conversion:

1. Remove the right side wood panel (4 screws), then the rear/top metal panel (6 screws).
2. Set the power frequency selector slide switch (located next to the capstan motor) to the 50 or 60 position to match the power line frequency in your area.
3. Rotate the center (capstan) motor clockwise with your hand and re-position the belt onto the correct pulley as shown in the motor pulley illustration below.  
The pulley can be seen by looking through the opening in the side panel. Continue to rotate the motor by hand approximately 10 revolutions to verify belt placement before replacing the side and rear covers.

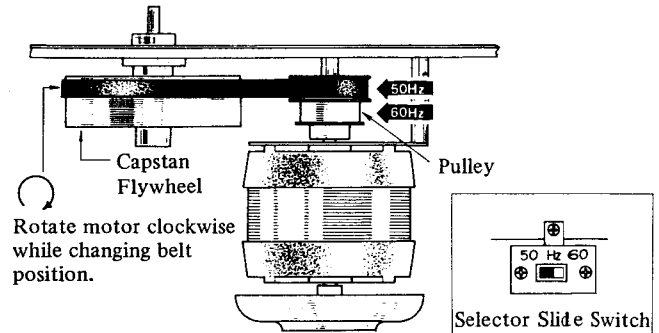

Fig. 7-6 Frequency Conversion

### Voltage Conversion:

The deck may be set for 100, 117, 220 or 240 volts. To change the voltage unscrew the fuse in the center of the voltage selector plug. Pull out the plug and reinsert it so the desired voltage shows in the cutout. Reinstall the fuse specified on the label on the rear of the deck.

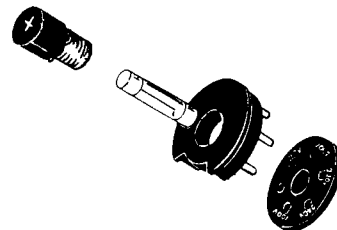

Fig. 7-7 Voltage Conversion

## 8. MEASUREMENT AND ADJUSTMENT

### — ELECTRICAL —

- Before performing maintenance on this unit, thoroughly clean and demagnetize the entire tape path. TEAC maintenance equipment to be used:  
TEAC TZ-261 for cleaning  
TEAC E-3 for demagnetizing or equivalent
- The electrical adjustment procedure for the A-3300SR and A-2300SR are identical, also, the tape speeds of the two models are the same (7-1/2 ips, HIGH and 3-3/4 ips, LOW speed).  
The checks and adjustments are, unless otherwise indicated, for the left channel at the LOW tape speed. The same procedures are to be applied for the right channel also and again for both channels at the HIGH tape speed.
- It is important that the deck be set to proper voltage and frequency for your locality.

### 8-1 ADJUSTMENT LOCATIONS AND ADJUSTMENT POINTS

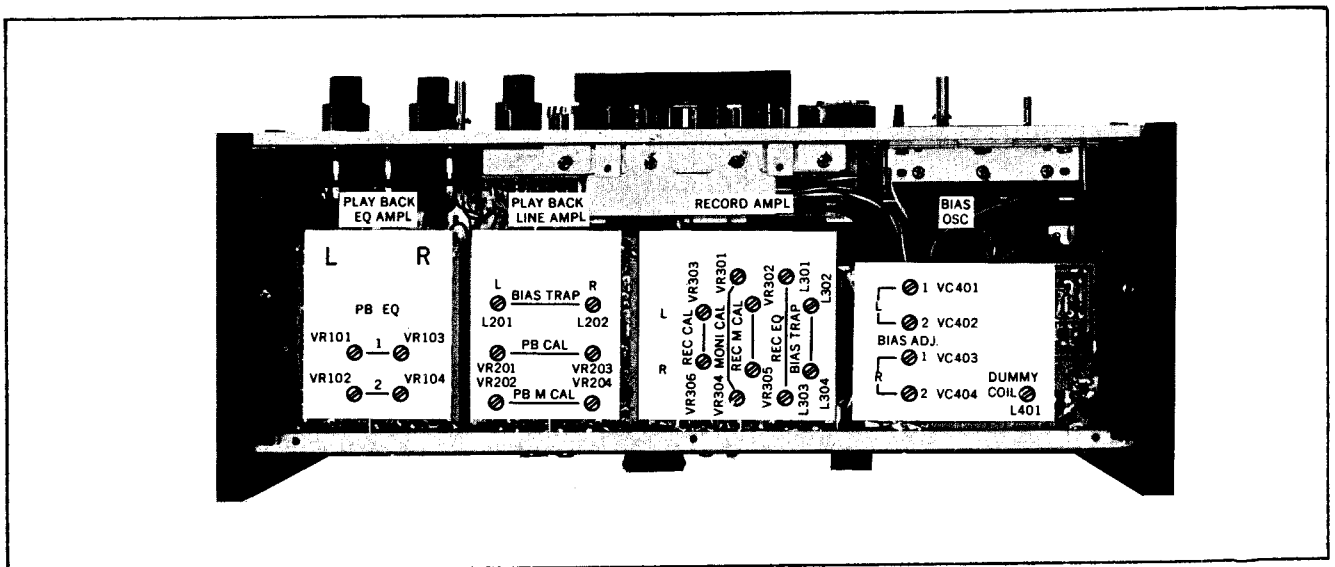

ADJUSTMENT	FOR
VR101/103	P.B.EQ (HIGH)
VR102/104	P.B. EQ (LOW)
VR201/203	P.B. LEVEL
VR202/204	P.B. METER LEVEL
VR301/304	MONITOR LEVEL
VR302/305	REC METER LEVEL
VR303/306	REC LEVEL

ADJUSTMENT	FOR
VC401/403	BIAS ADJ. (1)
VC402/404	BIAS ADJ. (2)
L201/202	BIAS TRAP (OUTPUT)
L301/303	REC EQ
L302/304	BIAS TRAP
L401	DUMMY COIL

## 8-2 ADJUSTMENT SEQUENCE CHART

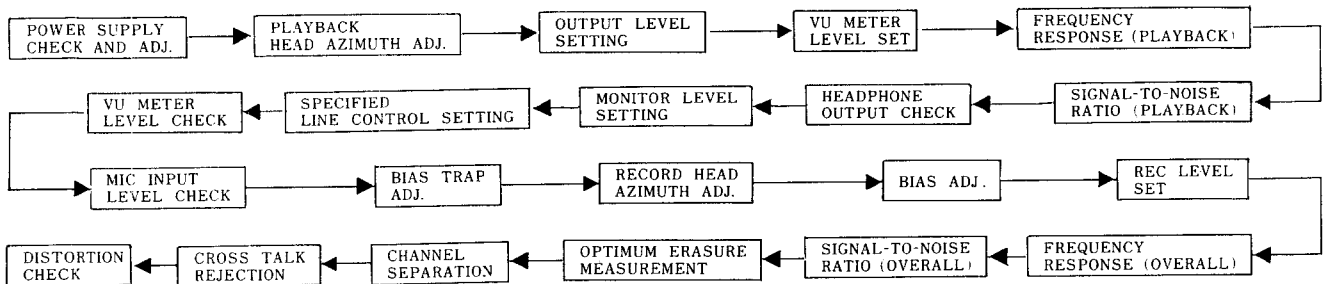

Fig. 8-1 Adjustment Sequence Chart

## PLAYBACK PERFORMANCE

### 8-3 POWER SUPPLY CHECK AND ADJ.

1. Remove wooden panel on left side of the deck for access to the electrical adjustments.
2. Depress power SW to ON.
3. Connect a VTVM between the Power Supply P.C. Bd. Test Point No. 13 and ground. See Fig. below.
4. Adjust R56 for +23 V DC. (see REAR VIEW on p. 9.)

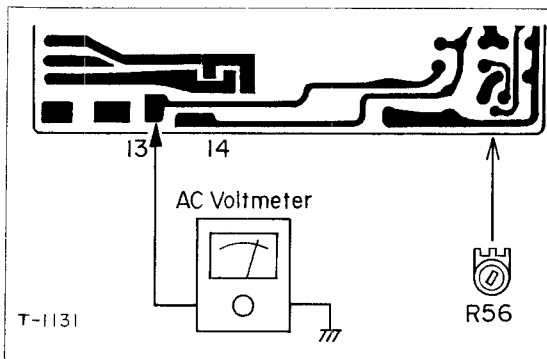

Fig. 8-2 +23 V DC Test Point

### 8-4 PLAYBACK HEAD AZIMUTH ADJ.

**NOTE:** Before proceeding with the following head alignments be sure that heads have been properly mounted as to HEIGHT, TILT and TANGENCY. See page 10.

1. Connect a VTVM to either OUTPUT jack.
2. Remove the head Housing (on front panel).
3. Thread the following TEAC Test Tape YTT-1002 on the deck.
4. Play the 10 kHz Test Tone in section 2 of the Test Tape.
5. Slowly rotate the azimuth screw until maximum indication is achieved on VTVM.
6. Connect an oscilloscope to the OUTPUT jacks as shown in Fig. 8-3.
7. Adjust the azimuth screw (If necessary) until the oscilloscope shows that the signals are less than 45° out of phase.
8. Secure this screw with a drop of locking paint.

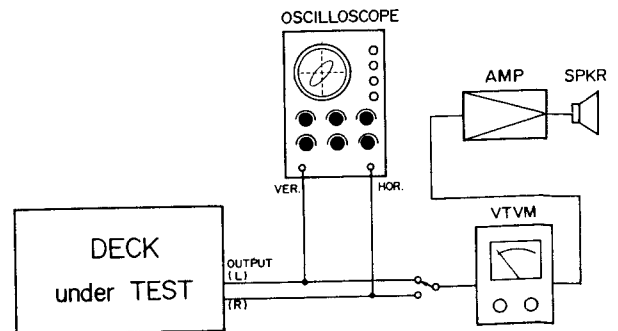

Fig. 8-3 Head Alignment Fine Adjustment Set-up and Test Connections (PLAYBACK)

### — FINE ADJUSTMENT —

TAPE SPEED SW ..... LOW  
 OUTPUT SW ..... TAPE  
 REEL SW ..... SMALL

## 8-5 OUTPUT LEVEL SETTING

### – MAXIMUM OUTPUT LEVEL CHECK –

10. Play the 400 Hz/0 dB tone in section 1 of the Test Tape.
11. Turn the OUTPUT controls fully clockwise.
12. Adjust VR-201/203 for –2 dB (615 mV) at OUTPUT jacks.

### – SPECIFIED OUTPUT LEVEL SETTING –

13. Reduce both OUTPUT controls together until the lower reading channel reads –8 dB. (approx. 2 o'clock position). If there is a difference in level between L-ch and R-ch, again adjust VR-201/203 (whichever is higher) for –8 dB (308 mV).

**NOTE:** This is the Specified Output level setting. Do not disturb this setting until the remaining adjustments have been completed.

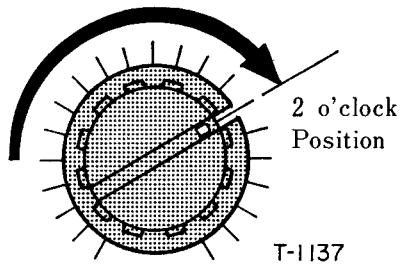

Fig. 8-4 Specified Output Level Setting

## 8-6 VU METER LEVEL SET

14. Adjust VR-202/204 for 0 VU reading on VU meters.

## 8-7 FREQUENCY RESPONSE (PLAYBACK)

15. Thread TEAC Test Tape YTT-1002 on the deck.
16. Play Tape and compare readings on VTVM with the response limits given in Fig. 8-5.
17. If adjustment is required, adjust VR-102/104 for LOW speed.

**TAPE SPEED SW . . . . . HIGH**

18. Thread a Test Tape YTT-1003 on the deck. Repeat Step 16.
19. If adjustment is required, adjust VR-101/103 for HIGH speed.
20. Depress Reverse Play (◀) button and check for suitable output from both channels. See response limits given in Fig. 8-5.

**NOTE:** If the frequency response does not meet specified response limits, especially at the high-end of the spectrum, head should be checked for accumulated dirt or oxides. If clean, head azimuth must be re-adjusted.

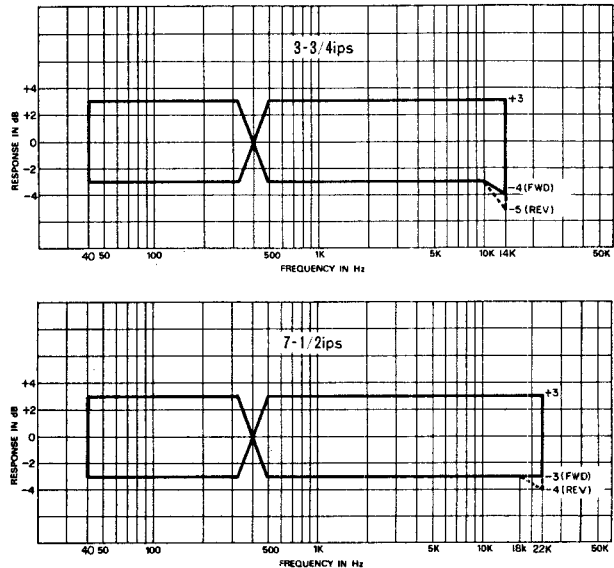

Fig. 8-5 Frequency Response – Playback –

## 8-8 SIGNAL-TO-NOISE RATIO (PLAYBACK)

1. OUTPUT controls should be at the Specified Output Level settings.
2. Thread a blank Test Tape on the deck leaving the tape outside the capstan and pinch roller.
3. Hold the play supply reel stationary and depress the play (▶) or (◀) button.
4. The VTVM connected to the OUTPUT jacks should indicate readings listed below, or better.

–57 dB, or more . . . . HIGH (7-1/2 ips)  
 –55 dB, or more . . . . LOW (3-3/4 ips)

**NOTE:** This corresponds to Signal-to-Noise Ratio of 49 dB (for HIGH) and 47 dB (for LOW): Difference between residual noise of –57 dB/–55 dB and specified output level of –8 dB.

### 8-9 MONITOR LEVEL SETTING

OUTPUT SW . . . . . SOURCE

1. Turn LINE controls fully clockwise.
2. Apply a 400 Hz -18 dB (97 mV) signal from AF oscillator to LINE IN jacks.
3. Adjust VR-301/VR-304 for -8 dB (308 mV) at the OUTPUT jacks.

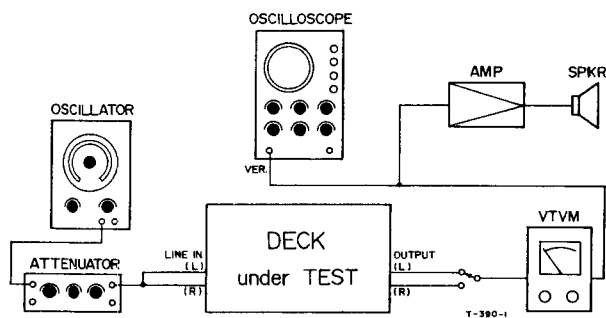

Fig. 8-6 Test Connections for Monitor Check

### 8-10 SPECIFIED LINE CONTROL SETTING

4. Apply a 400 Hz signal at -8 dB (308 mV) to the LINE IN jacks.
5. Adjust LINE controls for -8 dB (308 mV) at OUTPUT jacks.

**NOTE:** At this point both the LINE controls and the OUTPUT Controls are at the "Specified setting". Do not move these controls unless instructed in this procedure to do so. The accuracy of many of the following adjustments and readings depends on these controls being at the "Specified setting".

### 8-11 VU METER LEVEL CHECK

6. Check VU Meters for 0 VU indication.
7. Adjust VR-302/305 for 0 VU, if necessary.

### 8-12 MIC INPUT LEVEL CHECK

This is check only, no adjustments are to be made.

1. Apply a 400 Hz signal at -70 dB (0.244 mV) to the MIC Input jacks (on front panel).
2. Check for -8 dB  $\pm$  2 dB (244 mV ~ 388 mV) at OUTPUT jacks. When MIC Land R controls are at MAX. position.
3. Change the Input signal to -60 dB Level (0.774 mV).
4. Adjust MIC Level controls L and R for -8 dB (380 mV) at the OUTPUT jacks.
5. Return MIC Level controls fully counter clockwise (min.) to prevent noise insertion during following steps.

### 8-13 HEADPHONE OUTPUT CHECK

1. With the controls set as described in Step 8-5, connect an 8 ohm non-inductive resistor across the head phone (PHONE) jack.
2. Connect VTVM across the resistor while playing back operating level on Test Tape. VTVM should indicate -24 dB  $\pm$  2 dB (61.5 mV~38.8 mV).



**8-14 BIAS TRAP ADJUSTMENT**

OUTPUT SW ..... TAPE  
 REC MODE SW ..... ON  
 BIAS and EQ SW ..... 1  
 Select REC PAUSE mode

1. Remove all input signals.
2. Connect a VTVM or Oscilloscope from ground to the junction of L-302 and C-312 (L-ch) and from ground to the junction of L-304 and C-330 (R-ch). See Fig. 8-7.
3. Adjust L-302 (L-ch) and L-304 (R-ch) for minimum reading on scope or VTVM.  
 Use Plastic alignment tool.

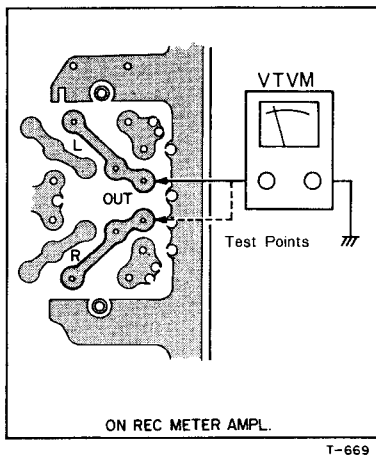

Fig. 8-7 Bias Trap Test Point

**8-15 RECORD HEAD AZIMUTH ADJ.**

Tape SPEED SW ..... LOW

**NOTE:** The effect of turning the azimuth screw will register on the VTVM. A slight delay will be noticed. Therefore, the screw must be rotated slightly with a pause to see the effect.

— FINE ADJUSTMENT —

4. Connect a VTVM to the OUTPUT jack and an AF oscillator to the LINE IN jack.  
 Set the oscillator to 10 kHz at -18 dB (97 mV).
  5. Begin recording (Depress REC and PLAY buttons).
  6. While recording and monitoring the tape playback, adjust the azimuth screw for maximum reading on the VTVM.
- NOTE:** It is absolutely essential to accomplish the above adjustment before performing the following adj. to avoid phase errors greater than 45°.
7. Sweep the signal from 40 Hz to 16 kHz for 7-1/2 ips speed (or 40 Hz to 10 kHz for 3-3/4 ips speed) and adjust the azimuth so all signal are within 45° between channels.
  8. Secure the screw with insulating locking paint.

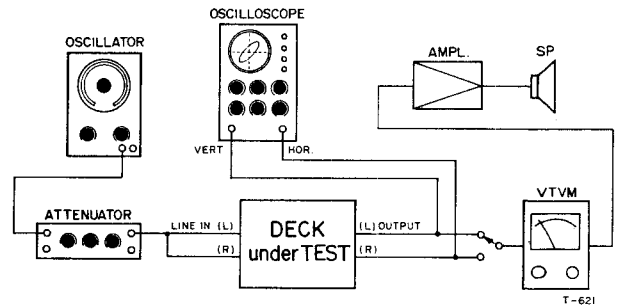

Fig. 8-8 Test Connection for Recording Check

**8-16 BIAS ADJUSTMENT**

Be sure the Bias Trap have been adjusted per section 8-14 before proceeding.

Tape SPEED SW ..... LOW  
 BIAS and EQ SW ..... 1

9. Apply 7 kHz signal at -18 dB (97 mV) to the LINE IN jacks.
10. While recording on the YTT-8013 Test Tape, adjust capacitor VC-401/VC-403 for peak reading on the VTVM, then turn the capacitor clockwise until a decrease of 4 dB from the peak is obtained.

BIAS and EQ SW ..... 2

11. Apply 400 Hz signal at -8 dB (308 mV) to the LINE IN jacks.
12. While recording on the YTT-8023 Test Tape, adjust capacitor VC-402/VC-404 for peak Bias.

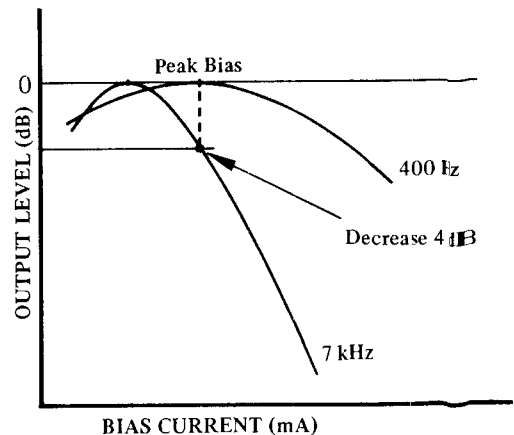

Fig. 8-9 Bias Limits Chart

### 8-17 REC LEVEL SET

13. Place BIAS SW and EQ SW to the 1 position.
14. Thread a blank Test Tape YTT-8013 on the deck.
15. Place Tape SPEED SW to the 7-1/2 ips position.
16. Apply a 400 Hz signal at -8 dB (308 mV) to the LINE IN jacks.
17. Begin recording.
18. Adjust VR-303/306 for -8 dB (308 mV) at OUTPUT jacks.

### 8-18 FREQUENCY RESPONSE -OVERALL-

**NOTE:** To avoid saturation of the tape these checks should be made at least 20 dB below the specified input level.

Any Bias signal feeding into the test equipment should be filtered out by adjusting the external Bias Trap.

BIAS and EQ SW ..... 1  
Tape SPEED SW ..... LOW

19. Apply signal swept from 40 Hz to the upper frequency limit shown in the applicable Response Limits Chart below, and record this signal on the YTT-8013 test tape for BIAS/EQ 1 and on the YTT-8023 test tape for BIAS/EQ 2.
20. During recording, monitor the tape signal and adjust equalization L-301/L-303 for +2 dB reading at 14 kHz so that reading is within the applicable Response Limits Chart.
21. Repeat this procedure for High Speed also, using the frequency limits given in the applicable Response Limits Chart.

BIAS and EQ SW ..... 2  
Using blank Test Tape ..... TEAC YTT-8023

**NOTE:** If the response is not uniform, the heads should be cleaned of accumulated oxide and dirt. Then adjust VC-402/404 Bias Adjuster slightly to obtain the best frequency response.

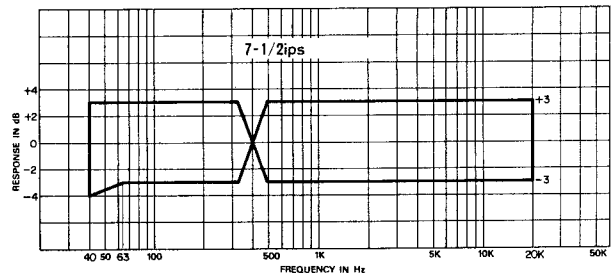
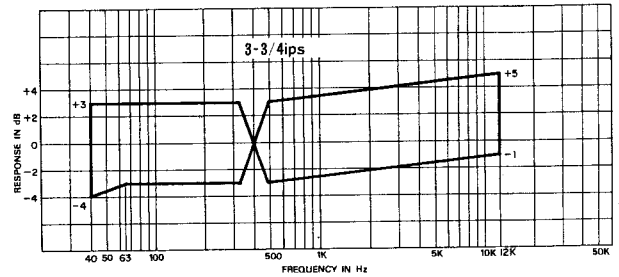

Fig. 8-11 Frequency Response - OVERALL - 2

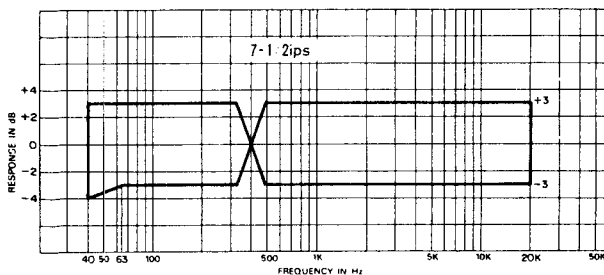
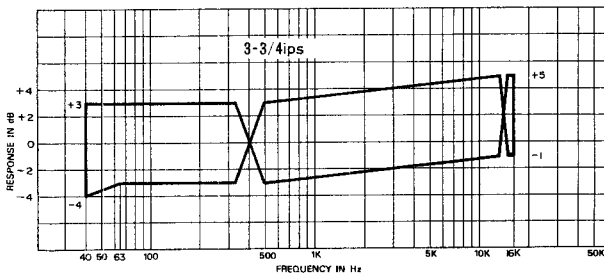

Fig. 8-10 Frequency Response - OVERALL - 1

## 8-19 SIGNAL-TO-NOISE RATIO —OVERALL—

Using blank Test Tape . . . . . YTT-8013

1. Output and Line controls should be at the specified positions.
2. Remove the AF oscillator from the LINE IN L, R jacks.
3. Place the deck in the Record mode with "no signal" applied. Note the point on the index counter where recording begins.
4. Rewind the tape to the beginning point and play it back.
5. The noise level as indicated on the VTVM should be readings listed below.

—55 dB, or more . . . . HIGH (7-1/2 ips)

—53 dB, or more . . . . LOW (3-3/4 ips)

**NOTE:** This —55 dB/—53 dB corresponds to the Signal-to-Noise Ratio of 47 dB/45 dB (minimum): the difference between residual noise of —55 dB/—53 dB and specified output level —8 dB.

**NOTE:** Since this measurement method and the measurement methods used to obtain the catalog and owner's manual S/N spec, are different, the values here and in the catalog and Owner's manual will be different.

## 8-20 OPTIMUM ERASURE MEASUREMENT

Tape SPEED SW . . . . . HIGH

1. Thread the TEAC YTT-8013 Test Tape on the deck.
2. Apply a 1 kHz signal at 10 dB above the operating level of —8 dB (308 mV) to the LINE IN jack.
3. Make a 30 second recording of the above signal while reading and noting the level of output, then rewind to beginning of this recording.
4. Disconnect the 1 kHz signal source (AF oscillator) from the LINE IN jack.
5. Connect a VTVM to the OUTPUT jack, through a 1 kHz Narrow Band Pass Filter.
6. Put deck in the Record mode and "record" (erase) over this previous recording, then rewind to beginning again.
7. Put deck in Play mode and monitor the output on the VTVM.
8. Difference in output level, between the 1 kHz signal and the "no signal" section level should be more than 68 dB.

**NOTE:** Filter loss should be considered.

## 8-21 CHANNEL SEPARATION

1. Be sure tape is completely bulk erased prior to doing these checks.
2. Apply a 1 kHz signal at —8 dB (308 mV) to L chan.
3. Place deck in Record mode.
4. While recording, measure the OUTPUT on R chan with VTVM connected through a 1 kHz Band Pass Filter. Spec. should be 50 dB.

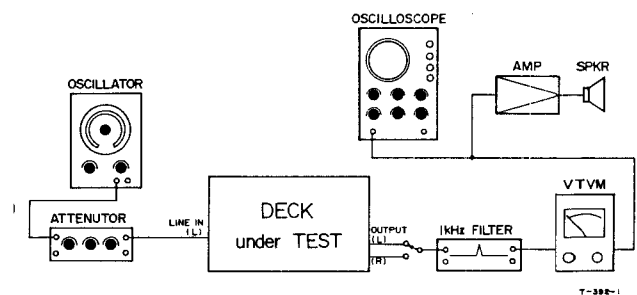

Fig. 8-12 Test Connections for Channel separation check

## 8-22 TRACK-TO-TRACK CROSS TALK REJECTION

Following is the measurement procedure at 7-1/2 ips using the TEAC standard tape, Type YTT-8013:

1. Thread the TEAC YTT-8013 Test Tape on the deck.
2. Apply a 125 Hz signal at —8 dB to the right channel LINE IN jack.
3. Make a 30 second recording of the 125 Hz signal.
4. Interchange the left and right reels and rethread tape on the deck.
5. Connect a VTVM to the right channel OUTPUT jack.
6. Playback the recorded signal portion of tape and monitor the level on the VTVM.
7. Spec. should be 40 dB or better.

## 8-23 DISTORTION CHECK

Tape SPEED . . . . . 7-1/2 ips

BIAS and EQ SW . . . . . 1

1. Thread the TEAC YTT-8013 Test Tape on the unit.
2. With Line and Output Controls at Operating (specified) Level, apply a 1 kHz signal to LINE IN jacks, at 0 VU.
3. Place the deck in the record mode for about 10 seconds. Rewind and play this recorded section of the tape.
4. Read the indicated value on the distortion analyzer.
5. The distortion factor should be 1.0% or less.

## 9. SERVICING AND MAINTENANCE

### 9-1 CLEANING:

TEAC TZ-261A for Head cleaning and TZ-261B for Rubber cleaning should be used. Use for following places.

TZ-261B	TZ-261A
Pinch roller rubber Capstan belt Counter belt	Motor pulley Heads, Brake drums Capstan shaft Tape run guides

### 9-2 LUBRICATION:

Under normal operating conditions, lubrication is required only once each year. Before lubricating, clean the drive belt and drive pulley... etc. Operate the deck for 30 minutes to 1 hour immediately prior to oiling. After oiling, keep the deck in the upright position for 3 to 4 hours to allow thorough absorption of the oil.

Approximately once each year or after 2000 hours of use, apply TEAC TZ-255 Lubricating Oil to the following places only;

- Pinch roller shaft ..... 1 drop
- Capstan shaft ..... 2 drops  
(Remove the dust cap for access to the oil pit)
- Capstan motor and Reel Motors (A-2300SR only) 0.5 cc  
(Maximum to fill oiling tube)

**NOTE:** Apply 3 or 4 drops at a time through the oiling tube. The oil level can be seen to drop as the felt material in the motor bearings absorb oil. When the level ceases to drop, no more oil is needed. Do not attempt to force oil into the motor nor exceed the maximum.

Excessive oiling will scatter oil inside the deck. This oil will cause drive belt slippage and other difficulties. Check for slippage and clean all parts inside the deck before operating after lubrication. Check for oil emission after operation and before returning deck to the customer.

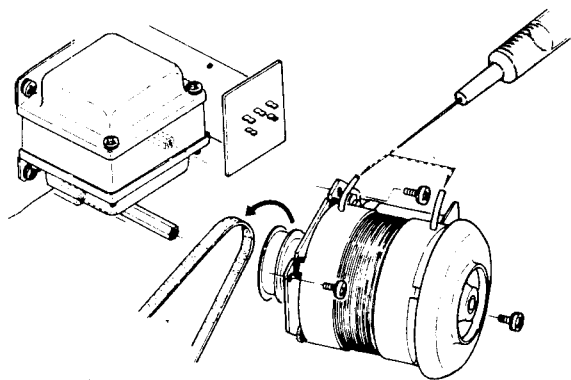

Fig. 9-1 Capstan Motor Oiling Point

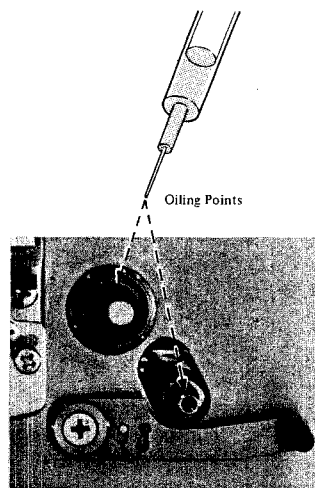

Fig. 9-2 Capstan Shaft and Pinch Roller Shaft Oiling Points

### 9-3 TEAC MAINTENANCE FLUIDS

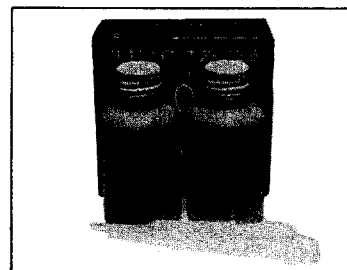

Fig. 9-3 TZ-255 Oil Kit



Fig. 9-3 TZ-261 Cleaner

### 9-4 DEMAGNETIZATION OF HEADS

If the Record or Playback heads become magnetized, noise will increase and tonal fidelity will deteriorate. For this reason it is advisable to use non-magnetic tools when working near the heads. If the heads have had any contact with current carrying or magnetized metal parts, demagnetize them with a TEAC E-3 eraser or Equivalent.

# 10. SIMPLIFIED SCHEMATIC

— with level indications —

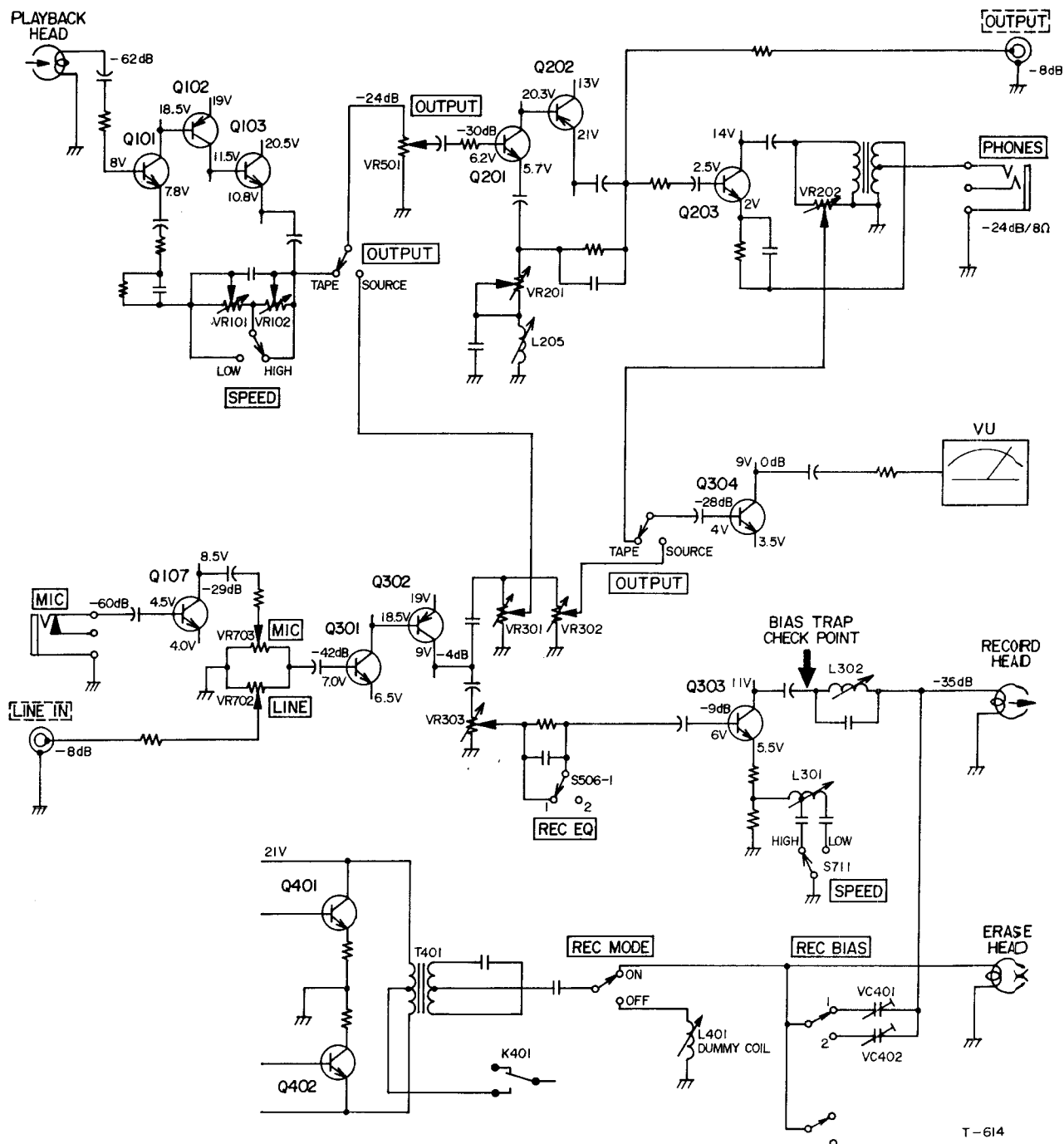

- NOTE:**
1. Schematic shown for the LEFT channel only.
  2. Monitor switch shown in TAPE, SPEED SW in HIGH position.
  3. Circuit signal Level obtained with High input impedance AC VTVM. Reading in dB Referenced to 0 dB = 0.775V.
  4. Signal Level reading were obtained under the following conditions.  
Signal ..... 400 Hz.  
MIC, Line control and Output controls at specified levels.



**A-3300SR / A-2300SR** Stereo Tape Deck

**TEAC**

**TEAC CORPORATION**

3-7-3, NAKA-CHO, MUSASHINO, TOKYO PHONE: (0422) 53-1111

TEAC CORPORATION OF AMERICA

7733 TELEGRAPH ROAD, MONTEBELLO, CALIFORNIA 90640 PHONE: (213) 728-0303

PRINTED IN JAPAN 0578 KOS 2.0 D-2802A

## PARTS LIST

# A-3300SR A-2300SR

Stereo Tape Deck

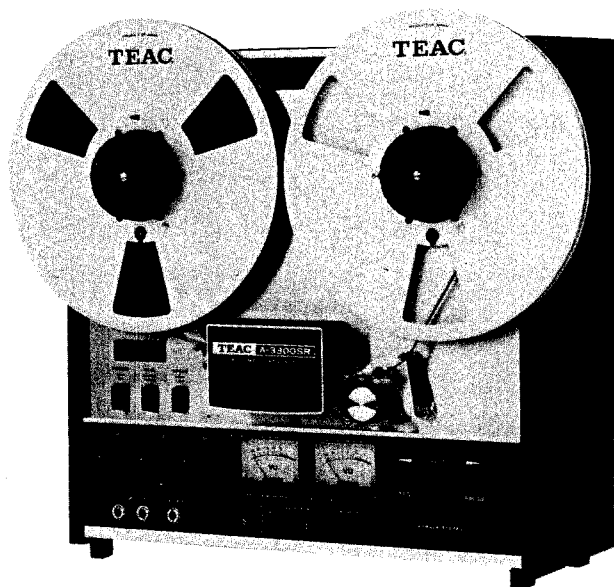

### TABLE OF CONTENTS

#### 1. EXPLODED VIEWS AND PARTS LIST SECTION

EXPLODED VIEW-1 (A-3300SR) .....	2, 3
EXPLODED VIEW-2 (A-2300SR) .....	4, 5
EXPLODED VIEW-3 (A-3300SR) .....	6, 7
EXPLODED VIEW-4 (A-2300SR) .....	8, 9
EXPLODED VIEW-5 (A-3300SR, A-2300SR) .....	10, 11
EXPLODED VIEW-6 (A-3300SR, A-2300SR) .....	12, 13

<b>INCLUDED ACCESSORIES</b> .....	<b>13</b>
-----------------------------------	-----------

#### 2. PC BOARD SECTION

1. EQ, MIC AMPL. PC BOARD .....	14, 20
2. LINE, PHONE AMPL. PC BOARD .....	14, 20
3. RECORD, METER AMPL. PC BOARD .....	15, 21
4. BIAS OSCILLATOR PC BOARD .....	15, 21
5. HEAD SELECT PC BOARD .....	16, 22
6. SWITCH MOUNTING PC BOARD .....	16, 22
7. CONTROL PC BOARD .....	17, 22
8. SENSING PC BOARD .....	17, 23
9. POWER SUPPLY PC BOARD .....	18, 23
10. CONTROL RELAY PC BOARD .....	18, 24
11. REEL MOTOR PC BOARD .....	19, 24

<b>TRANSISTOR SUBSTITUTION CHART</b> .....	<b>26</b>
--	-----------

<b>ASSEMBLING HARDWARE CODING LIST</b> .....	<b>27</b>
--	-----------

### PARTS ORDERING INFORMATION

Spare parts are available through your nearest TEAC Authorized Service Center or directly from the TEAC office, the address of which is written on the back cover. When ordering parts always include the following information:

- |              |                    |
|--------------|--------------------|
| 1. MODEL     | 4. DESCRIPTION     |
| 2. REF. NO.  | 5. UNIT SERIAL NO. |
| 3. PARTS NO. | 6. MANUAL CODE NO. |

#### NOTICE REGARDING PARTS ORDERS

1. Do not order by only REF. NO.
2. In some instance, individual minor parts are not available. In such a case, the entire assembly including the part requested will be sent to you.
3. Parts are identical between the different models with the exceptions as coded by the designations in the REMARKS column.
4. PC Boards shown viewed from foil side.
5. Parts marked with \* require longer delivery time than regular parts.

TEAC CORPORATION





REF. NO.	PARTS NO.	DESCRIPTION	REMARKS
1 - 1	*50134400	Plate, Head Base	
1 - 2	55201820	Spring, Head; D	
1 - 3	50220500	Spring, Head; B	
1 - 4	*50134371	Plate, Head	
1 - 5	50136540	Spacer, Erase Head	
1 - 6	55501511	Spacer, Head; A	
1 - 7	50663090	Head, Erase (4T-2CH)	
1 - 8	50664540	Head, Record (4T-2CH)	
1 - 9	50664590	Head, Playback (4T-4CH)	
1 - 10	*50133891	Case, Head Shield; A	
1 - 11	50136690	Bracket, Head Protector	
1 - 12	*51676050	PC Board, Head	
1 - 13	*50182672	Pin, Guide	
1 - 14	*55531001	Plate, Housing Base	
1 - 15	55040871	Reel Table Assy	
1 - 16	55041600	Arm Assy, Tension; B	
1 - 17	50182801	Bushing, Arm Assy; B	
1 - 18	55522640	Panel, Trim	
1 - 19	50112980	Grill Assy, Top	
1 - 20	*55045210	Pin Assy, Guide	
1 - 21	50180432	Arm Assy, Right Tension	
1 - 22	50182701	Bushing, Arm Assy; A	
1 - 23	50142180	Cap, Pinch Roller	
1 - 24	50141751	Pinch Roller	
1 - 25	*55447900	Cap, Dust; G	
1 - 26	50123900	Seal, Oil	
1 - 27	*55643720	Name Plate	
1 - 28	50136552	Housing, Head	
1 - 29	50123911	Cap, Guide Ring	
1 - 30	50123931	Ring, Guide	
1 - 31	50123921	Base, Guide Ring	
1 - 32	50162980	Escutcheon, Counter	
1 - 33	*50114248	Panel, Chassis	
1 - 34	*55542870	Plate, Meter Support	
1 - 35	50182730	Limit Stop, Tension Arm	
1 - 36	50529050	Spark Killer, 0.1 mfd + 120 ohm 400V	
1 - 37	51300010	Switch, Micro	
1 - 38	55203110	Spring, Right Tension	
1 - 39	*50183932	Plate, Insulator	
1 - 40	*50183921	Drum, Tension Arm	
1 - 41	*50331440	Plate, Chassis Panel	
1 - 42	50253530	Button, D	
1 - 43	*50253900	Mask, Switch; 2T	
1 - 44	*50237391	Plate, Switch	
1 - 45	50443902	Switch Assy	
1 - 46	*50332671	Spacer, Insulator Paper	
1 - 47	*50237083	Bracket, Power Switch	
1 - 48	51340210	Switch, Power	
1 - 49	50221110	Spring, B	
1 - 50	*50253881	Mask, Switch	
1 - 51	50276920	Nut, M9	
1 - 52	*55045501	Travel Limiter Assy, Tension Arm	
1 - 53	50276990	Collar, Rubber	
1 - 54	55044110	Screw Assy, Sideboard	
1 - 55	55810370	Screw, Guide	
1 - 56	55430070	Sideboard, A	
1 - 57	*50113422	Panel, Side; Right	
1 - 58	*50112713	Frame, Side	
1 - 59	50277111	Washer, Trim	
1 - 60	*50332541	Angle, PC Board	
1 - 61	51686090	PC Board Assy, REEL MOTOR	
1 - 62	55552100	Angle, PC Board; A	
1 - 63	50330111	Bracket, Resistor	

(Continued on page-25)

# EXPLODED VIEW-2 (A-2300SR)

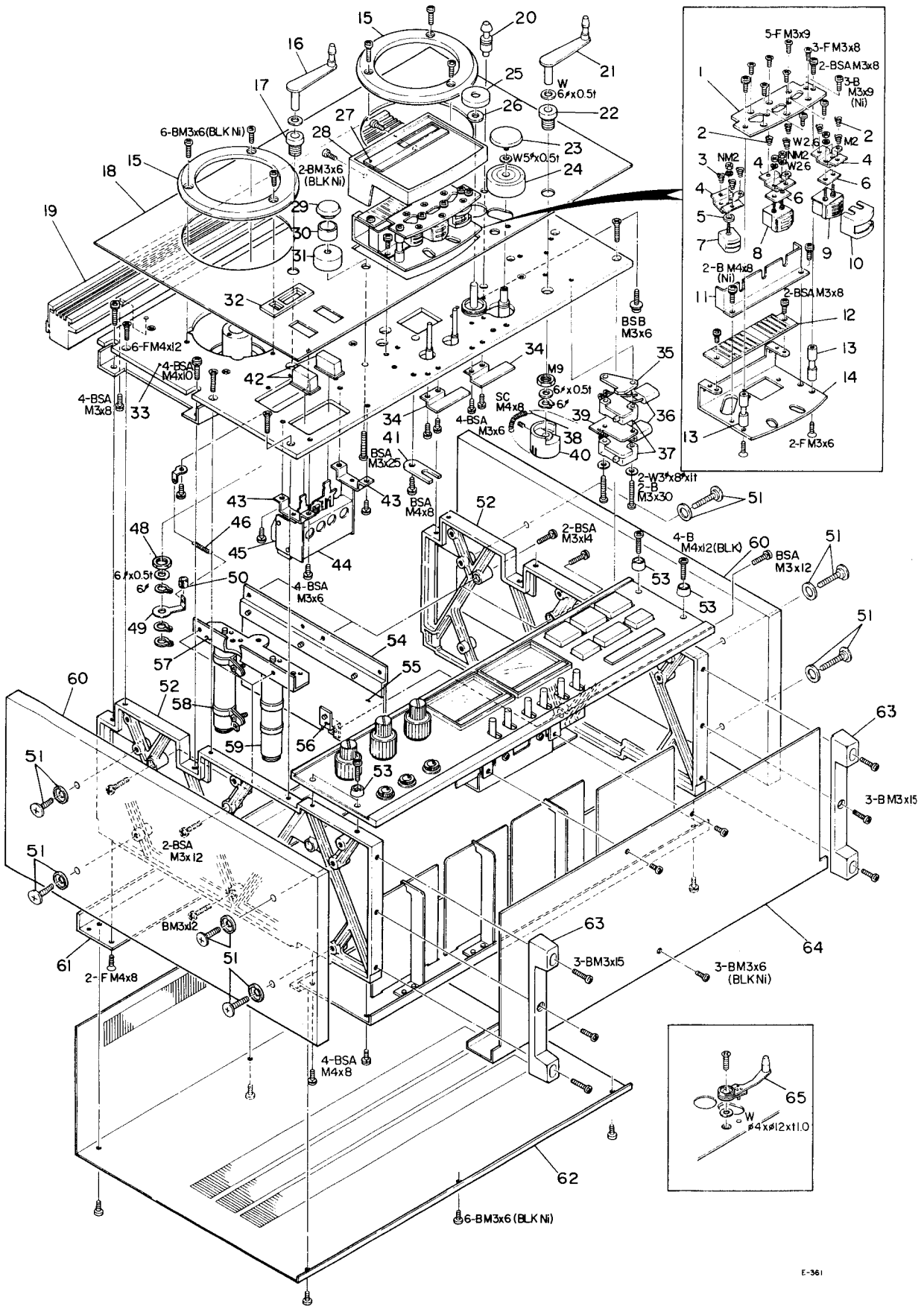

REF. NO.	PARTS NO.	DESCRIPTION	REMARKS
2 - 1	*50134400	Plate, Head Base	
2 - 2	55201820	Spring, Head; D	
2 - 3	50220500	Spring, Head; B	
2 - 4	*50134371	Plate, Head	
2 - 5	50136540	Spacer, Erase Head	
2 - 6	55501511	Spacer, Head; A	
2 - 7	50663090	Head, Erase (4T-2CH)	
2 - 8	50664540	Head, Playback (4T-2CH)	
2 - 9	50664590	Head, Record (4T-4CH)	
2 - 10	*50133891	Case, Head Shield; A	
2 - 11	50136690	Bracket, Head Protector	
2 - 12	*51676050	PC Board, Head	
2 - 13	*50182672	Pin, Guide	
2 - 14	55531001	Plate, Housing Base	
2 - 15	50161941	Reel Protector	
2 - 16	*50180560	Arm Assy, Left Tension; Y	
2 - 17	50182801	Bushing, Arm Assy; B	
2 - 18	55522650	Panel, Trim	
2 - 19	50112980	Grille Assy, Top	
2 - 20	*55045210	Pin Assy, Guide	
2 - 21	50180432	Arm Assy, Right Tension	
2 - 22	50182701	Bushing, Arm Assy; A	
2 - 23	50142180	Cap, Pinch Roller	
2 - 24	50141751	Pinch Roller	
2 - 25	*55447900	Cap, Dust; G	
2 - 26	50123900	Seal, Oil	
2 - 27	*55643700	Name Plate	
2 - 28	50136552	Housing, Head	
2 - 29	50123911	Cap, Guide Ring	
2 - 30	50123931	Ring, Guide	
2 - 31	50123921	Base, Guide Ring	
2 - 32	50162980	Escutcheon, Counter	
2 - 33	*50114279	Panel, Chassis	
2 - 34	*55542870	Plate, Meter Support	
2 - 35	50182730	Limit Stop, Tension Arm	
2 - 36	50529050	Spark Killer, 0.1 mfd + 120 ohm 400V	
2 - 37	51300010	Switch, Micro	
2 - 38	55203110	Spring, Right Tension	
2 - 39	*50183932	Plate, Insulator	
2 - 40	*50183921	Drum, Tension Arm	
2 - 41	*50331440	Plate, Chassis Panel	
2 - 42	50243890	Button, Switch	
2 - 43	*50237470	Bracket, Switch Mounting	
2 - 44	50443902	Switch Assy	
2 - 45	50332671	Spacer, Insulator Paper	
2 - 46	50221110	Spring, B	
2 - 47		(Not used)	
2 - 48	50276920	Nut, M9	
2 - 49	50182750	Travel Limiter, Tension Arm	
2 - 50	50276990	Collar, Rubber	
2 - 51	55044110	Screw Assy, Sideboard	
2 - 52	*50112713	Frame, Side	
2 - 53	50277111	Washer, Trim	
2 - 54	*50332541	Angle, PC Board	
2 - 55	51686081	PC Board Assy, REEL MOTOR	
2 - 56	55552100	Angle, PC Board; A	
2 - 57	*50330111	Bracket, Resistor	
2 - 58	50524470	Resistor, Wire Wound 150 ohm 40HAA	
2 - 59	50524030	Resistor, Wire Wound 500 ohm 40HAA	
2 - 60	55430060	Sideboard	
2 - 61	*50235312	Angle, Rear Cover	
2 - 62	*55530310	Cover, Rear	
	55031390	Cover Assy, Rear	
2 - 63	50277980	Leg, Case	
2 - 64	*55043351	Cover Assy, Bottom	
2 - 65	55043410	Lever Assy, Cue	

GENERAL EXPORT  
U.S.A., CANADA



REF. NO.	PARTS NO.	DESCRIPTION	REMARKS
3 - 1	50173571	Drum, Brake	
3 - 2	*55552720	Retainer, Brake	
3 - 3	*50173490	Spacer, Brake Retainer	
3 - 4	55552740	Brake Felt	
3 - 5	50173333	Band Assy, Brake; L	
3 - 6	*50173601	Plate, Brake Band Assy; R	
3 - 7	50616770	Solenoid, Brake	
3 - 8	71041071	Motor, Reel	
3 - 9	50173612	Band Assy, Brake; R	
3 - 10	50524020	Resistor, Wire Wound 300 ohm 40HAA	
3 - 11	50522320	Resistor, Wire Wound 600 ohm 40H	
3 - 12	50522440	Resistor, Wire Wound 100 ohm 30HAA	
3 - 13	*55551560	Bracket, Resistor	
3 - 14	*50484193	PC Board, MP	
3 - 15	51700050	Capacitor, MP (7 + 1.5) mfd x 2	GENERAL EXPORT
	51714600	Capacitor, MP 7 mfd x 2	U.S.A., CANADA
3 - 16	51521550	Transformer, Power	GENERAL EXPORT
	51521540	Transformer, Power	U.S.A., CANADA
3 - 17	*55554970	Bracket, Transformer	
3 - 18	51686110	PC Board Assy, CONTROL RELAY	
3 - 19	55551611	Bracket, PC Board	
3 - 20	*55021772	Chassis, Reel Motor; D	
3 - 21	*50161950	Standoff, Reel Motor	
3 - 22	50332530	Belt, Counter; P	
3 - 23	*50332520	Bracket, Counter	
3 - 24	50585140	Counter, Index	
3 - 25	51686180	PC Board Assy, SENSING	
3 - 26	50545650	Capacitor, MP (2 + 0.8) mfd 250V	
3 - 27	*50332380	Bracket, Slide Switch	GENERAL EXPORT
3 - 28	50444610	Switch, Slide	GENERAL EXPORT
3 - 29	50123984	Fan, Motor Cooling	
3 - 30	50701341	Motor, Capstan	
3 - 31	*50237521	Plate, Capstan Motor Mounting	
3 - 32	*50706211	Cushion, Rubber	
3 - 33	*50332790	Spacer, Rubber Cushion	
3 - 34	50124003	Pulley, Motor (50/60 Hz)	GENERAL EXPORT
	50125121	Pulley, Motor (60Hz)	U.S.A., CANADA
3 - 35	*50123850	Standoff, Capstan Motor	
3 - 36	*50152453	Plate, Lifter	
3 - 37	50150252	Arm Assy, Lifter; B	
3 - 38	*50152501	Pivot, Lifter Arm	
3 - 39	50221100	Spring, A	
3 - 40	51150242	Arm, Lifter; A	
3 - 41	51686070	PC Board Assy, POWER SUPPLY	
3 - 42	*55552110	Angle, PC Board; B	
3 - 43	*50277151	Angle, Thrust	
3 - 44	*50123860	Standoff, Thrust	
3 - 45	50277233	Plate, Thrust	
3 - 46	50123802	Flywheel, Capstan	
3 - 47	50123830	Belt, Capstan	
3 - 48	*50142190	Plate, Arm Support	
3 - 49	50120441	Capstan Assy, 19 cm/s	
3 - 50	50275690	Cushion, Rubber	
3 - 51	*55551910	Limit Stop, Pinch Roller	
3 - 52	50220441	Spring	
3 - 53	50140237	Arm Assy, Pinch Roller	
3 - 54	*50221152	Spring, Pressure	
3 - 55	*50141821	Pivot, Roller Arm	
3 - 56	50616760	Solenoid, Pinch Roller	
3 - 57	50422570	Diode, SIB01-06	

(Continued on page-25)



REF. NO.	PARTS NO.	DESCRIPTION	REMARKS
4 - 1	50173561	Drum, Brake	
4 - 2	55043100	Band Assy, Brake; F	
4 - 3	*50170150	Plate, Band Pressure	
4 - 4	*50170160	Angle, Band Mounting	
4 - 5	*50173650	Plate, Brake Band Assy	
4 - 6	71041043	Motor, Reel	
4 - 7	50616770	Solenoid, Brake	
4 - 8	*50172550	Retainer, Brake	
4 - 9	50173661	Band Assy, Brake; C	
4 - 10	50172641	Brake Felt	
4 - 11	51521550	Transformer, Power	GENERAL EXPORT
	51521540	Transformer, Power	U.S.A., CANADA
4 - 12	*55554970	Bracket, Transformer	
4 - 13	51686110	PC Board Assy, CONTROL RELAY	
4 - 14	55551611	Bracket, PC Board	
4 - 15	*50237462	Chassis, Reel Motor; S	
4 - 16	*50161950	Standoff, Reel Motor	
4 - 17	50545940	Capacitor, MP (3.9 + 0.9) mfd	GENERAL EXPORT
	50545960	Capacitor, MP 3.9 mfd	U.S.A., CANADA
4 - 18	*50162960	Cushion, Rubber; B	
4 - 19	50524110	Resistor, Wire Wound 1k ohm 30H	
4 - 20	*55501410	Bracket, Resistor	
4 - 21	50332560	Belt, Counter	
4 - 22	*50332520	Bracket, Counter	
4 - 23	50585140	Counter, Index	
4 - 24	51686180	PC Board Assy, SENSING	
4 - 25	50545650	Capacitor, MP (2 + 0.8) mfd 250V	
4 - 26	*50332380	Bracket, Slide Switch	GENERAL EXPORT
4 - 27	50444610	Switch, Slide	GENERAL EXPORT
4 - 28	50160334	Reel Table Assy	
4 - 29	50123984	Fan, Motor Cooling	
4 - 30	50701341	Motor, Capstan	
4 - 31	50124003	Pulley, Motor (50/60 Hz)	GENERAL EXPORT
	50125121	Pulley, Motor (60Hz)	U.S.A., CANADA
4 - 32	*50237521	Plate, Capstan Motor Mounting	
4 - 33	*50706211	Cushion, Rubber	
4 - 34	*50332790	Spacer, Rubber Cushion	
4 - 35	*50123850	Standoff, Capstan Motor	
4 - 36	*50152453	Plate, Lifter	
4 - 37	50150252	Arm Assy, Lifter; B	
4 - 38	*50152501	Pivot, Lifter Arm	
4 - 39	50221100	Spring, A	
4 - 40	50150242	Arm, Lifter; A	
4 - 41	51686071	PC Board Assy, POWER SUPPLY	
4 - 42	*55552110	Angle, PC Board; B	
4 - 43	*50277151	Angle, Thrust	
4 - 44	*50123860	Standoff, Thrust	
4 - 45	50277233	Plate, Thrust	
4 - 46	50123830	Belt, Capstan	
4 - 47	50123802	Flywheel, Capstan	
4 - 48	50120441	Capstan Assy, 19 cm/s	
4 - 49	*50142190	Plate, Arm Support	
4 - 50	50275690	Cushion, Rubber	
4 - 51	*55551910	Limit Stop, Pinch Roller	
4 - 52	50220441	Spring	
4 - 53	*50221152	Spring, Pressure	
4 - 54	50140237	Arm Assy, Pinch Roller	
4 - 55	*50141821	Pivot, Roller Arm	
4 - 56	50616760	Solenoid, Pinch Roller	
4 - 57	50422570	Diode, SIB01-06	

(Continued on page-25)



# EXPLODED VIEW-5 (A-3300SR,A-2300SR)

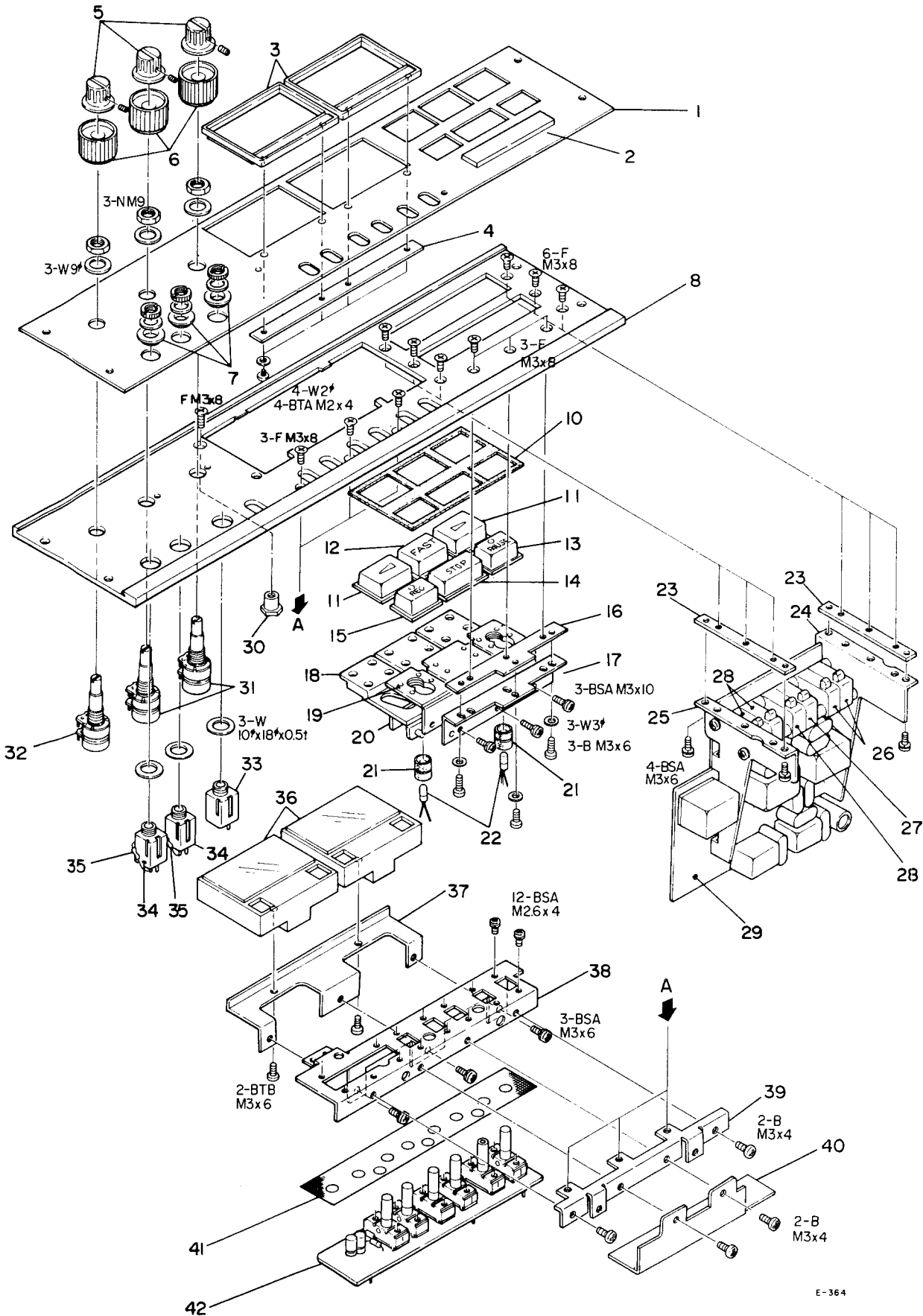

REF. NO.	PARTS NO.	DESCRIPTION	REMARKS
5 - 1	55522710	Panel, Ampl.; Trim	
5 - 2	55045321	Plate, 4 TRACK STEREO	
5 - 3	55301340	Escutcheon, Meter	
5 - 4	*55542650	Spacer, Escutcheon	
5 - 5	50253751	Knob, Upper	
5 - 6	55040591	Knob, Lower	
5 - 7	50332650	Washer, Insul.	
5 - 8	55521263	Panel, Ampl.	
5 - 9		(Not used)	
5 - 10	50237300	Protector, Rubber; P	
5 - 11	50237201	Button, A	
5 - 12	55300721	Button, FAST	
5 - 13	50237262	Button Assy, PAUSE	
5 - 14	50237221	Button, STOP	
5 - 15	50237233	Button Assy, REC	
5 - 16	*55505210	Plate Nut, Hinge; S	
5 - 17	*55505200	Bracket, Hinge; S	
5 - 18	*55340440	Hinge, B	
5 - 19	*55340430	Hinge, A	
5 - 20	*50237291	Plate Nut, PC Board	
5 - 21	50237490	Cushion, Lamp	
5 - 22	50414630	Lamp, Subminiature	
5 - 23	50237121	Plate	
5 - 24	50237141	Bracket, Switch; R	
5 - 25	50237131	Bracket, Switch; L	
5 - 26	50446560	Switch, Micro VV-15-1A	
5 - 27	50446570	Switch, Micro VV-15-2A	
5 - 28	50446580	Switch, Micro VV-15-3A	
5 - 29	51686390	PC Board Assy, CONTROL	A-3300SR
	51686060	PC Board Assy, CONTROL	A-2300SR
5 - 30	*50331430	Shaft, Panel Attaching	
5 - 31	51501461	Var. Res., 100k ohm - A x 2	
5 - 32	51501471	Var. Res., 10k ohm - A x 2	
5 - 33	50432450	Jack, Phone; 3 cond.	
5 - 34	50430240	Jack, Phone; Single	
5 - 35	50572980	Resistor, Carbon 4.7k ohm 1/4W	
5 - 36	51650280	Meter, VU	
5 - 37	*55530400	Bracket, Meter	
5 - 38	*55520543	Bracket, Switch	
5 - 39	*55530391	Angle, Bottom	
5 - 40	*55547390	Plate, Shield; A	
5 - 41	*55542661	Mask, Lever Switch	
5 - 42	51683310	PC Board Assy, SWITCH MOUNTING	

# EXPLODED VIEW-6 (A-3300SR,A-2300SR)

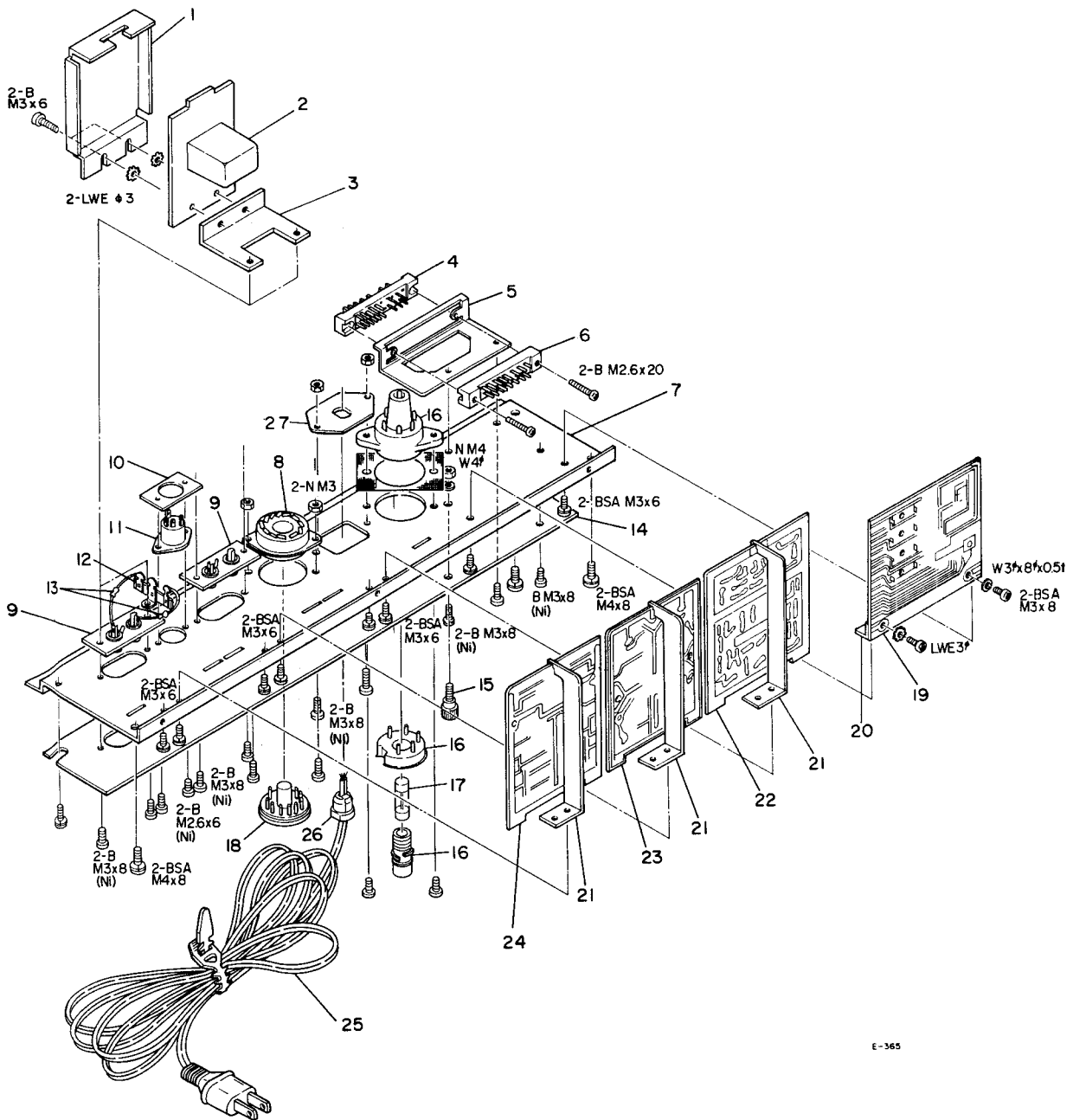

E-365

REF. NO.	PARTS NO.	DESCRIPTION	REMARKS
6 - 1	*55552160	Cover, Shield	
6 - 2	51686100	PC Board Assy, HEAD SELECT	
6 - 3	55552090	Bracket, PC Board; B	
6 - 4	51222780	Connector, Plug; 19P	
6 - 5	50237450	Bracket, Connector	
6 - 6	51222770	Connector, Socket; 19P	
6 - 7	55520161	Chassis, Ampl.; E	GENERAL EXPORT
	50237401	Chassis, Ampl.	U.S.A., CANADA
6 - 8	50432700	Connector, Socket; 11P	
6 - 9	50334632	Jack, Pin; 2P	
6 - 10	50233530	Plate, DIN Connector	
6 - 11	50430010	Connector, DIN	
6 - 12	50452060	Terminal Strip, 1L-2P	
6 - 13	50573300	Resistor, Carbon; 100k ohm ¼W	
6 - 14	*55522670	Panel, Rear Trim; E	GENERAL EXPORT
	*55522680	Panel, Rear Trim	U.S.A., CANADA
6 - 15	50454071	Post, Grounding	GENERAL EXPORT
6 - 16	50435030	Voltage Selector (w/Fuse)	GENERAL EXPORT
6 - 17	51422110	Fuse, 3A; 100V/117V area	GENERAL EXPORT
	50411140	Fuse, 2A; 220V/240V area	GENERAL EXPORT
6 - 18	50433001	Dummy Plug, 11P	
6 - 19	50490873	PC Board Assy, BIAS OSC	
6 - 20	50332550	Angle, PC Board	
6 - 21	50233760	Plate, PC Board	
6 - 22	51686490	PC Board Assy, RECORD/METER AMPL.	
6 - 23	51686650	PC Board Assy, LINE/PHONE AMPL.	
6 - 24	51686820	PC Board Assy, EQ/MIC AMPL.	
6 - 25	51280270	Cord, AC Power	GENERAL EXPORT
	51273670	Cord Assy, AC Power	U.S.A., CANADA
6 - 26	55300470	Strain Relief, AC Power Cord	
6 - 27	55541540	Plate, Strain Relief	
6 - 28	51222610	Connector, Pin Lock; 4P	

## INCLUDED ACCESSORIES

REF. NO.	PARTS NO.	DESCRIPTION	REMARKS
	51280010	Cords, Input-output Connection, 2 used	
	RE-1002	Empty Reel, 10 inch	A-3300SR
	RE-702	Empty Reel, 7 inch	A-2300SR
	55980250	Reel Adapter Clamp	A-3300SR
	50276971	Rubber Feet	For Horizontal Use
	50629620	Splicing Tape	
	50272880	Sensing Foil	
	51013371	Open Reel Supplement	U.S.A., CANADA
	51015310	A-3300SR Owner's Manual	GENERAL EXPORT
	51015300	A-3300SR Owner's Manual	U.S.A., CANADA
	51015290	A-2300SR Owner's Manual	GENERAL EXPORT
	51015280	A-2300SR Owner's Manual	U.S.A., CANADA

## 2. PC BOARD SECTION (Diagram)

### 2-1. EQ, MIC AMPL. PC BOARD

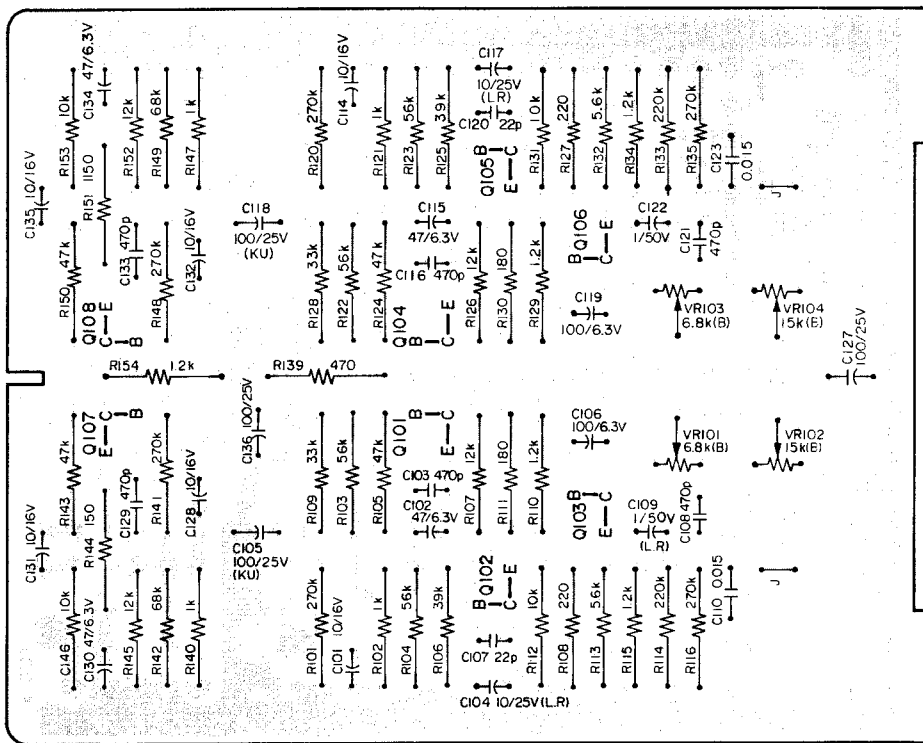

P-372

### 2-2. LINE, PHONE AMPL. PC BOARD

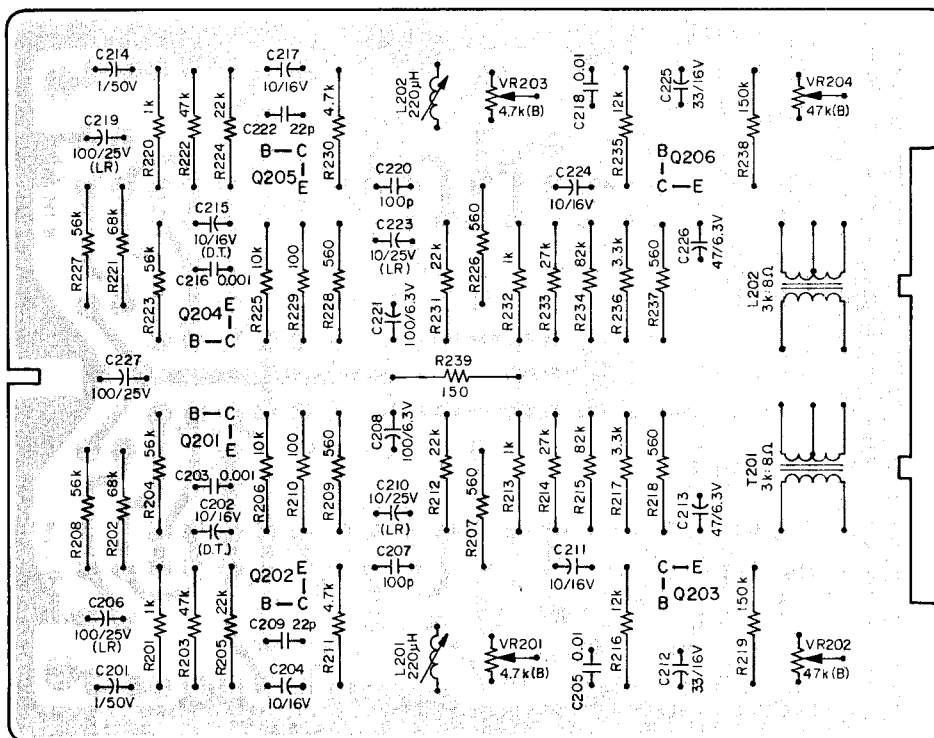

P-373

### 2-3. RECORD, METER AMPL. PC BOARD

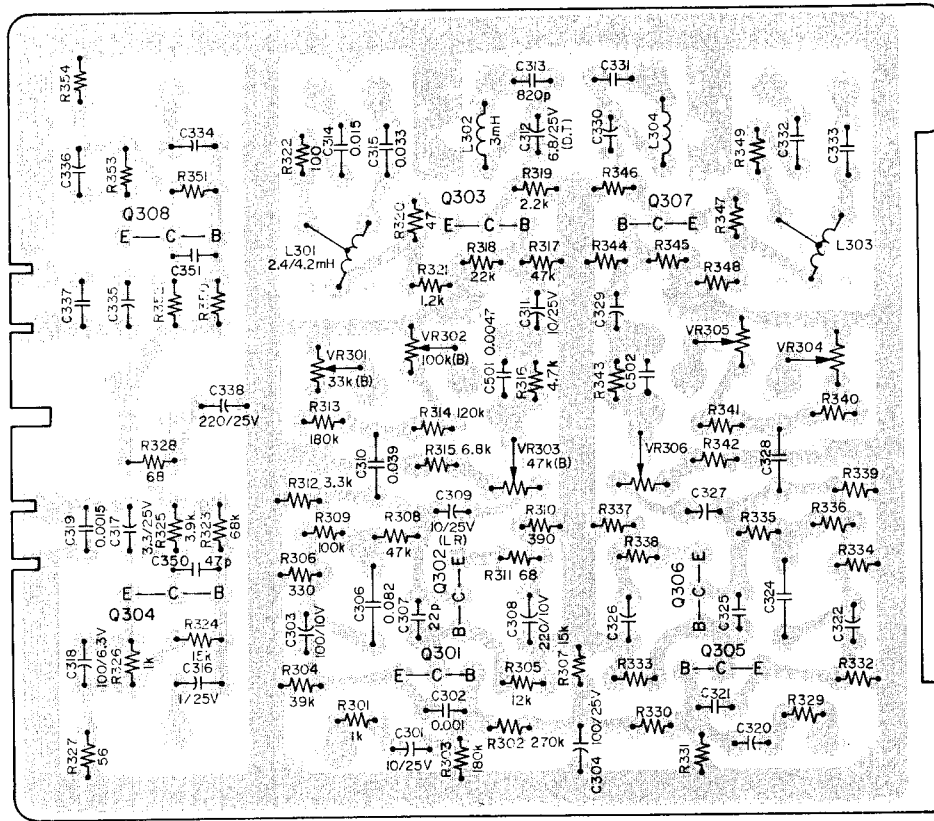

P-247

### 2-4. BIAS OSCILLATOR PC BOARD

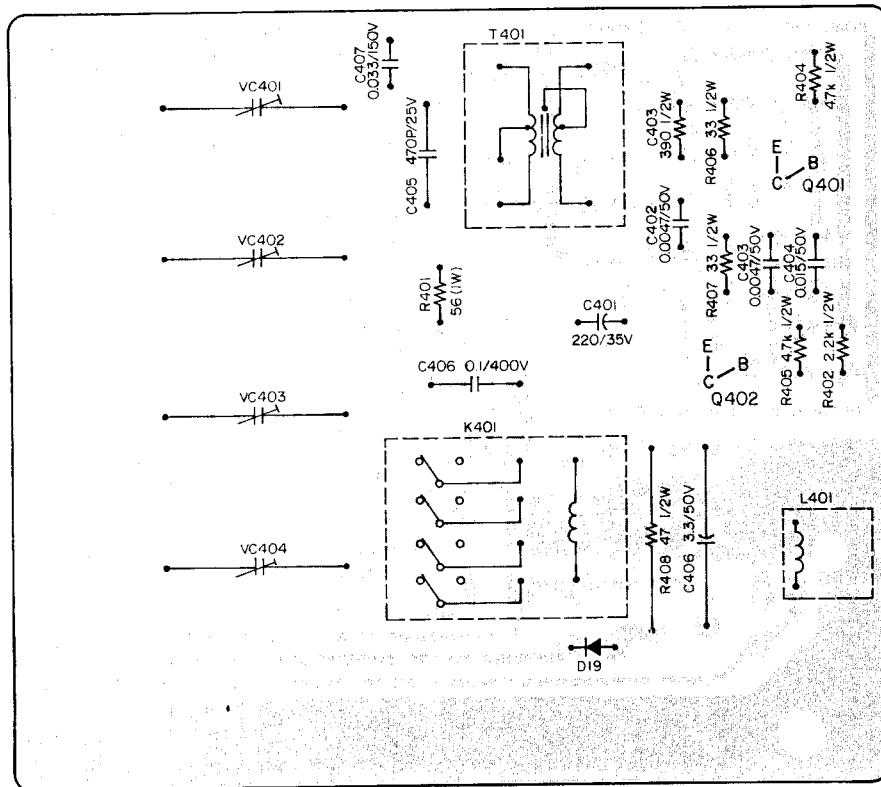

P-248

## 2-5. HEAD SELECT PC BOARD

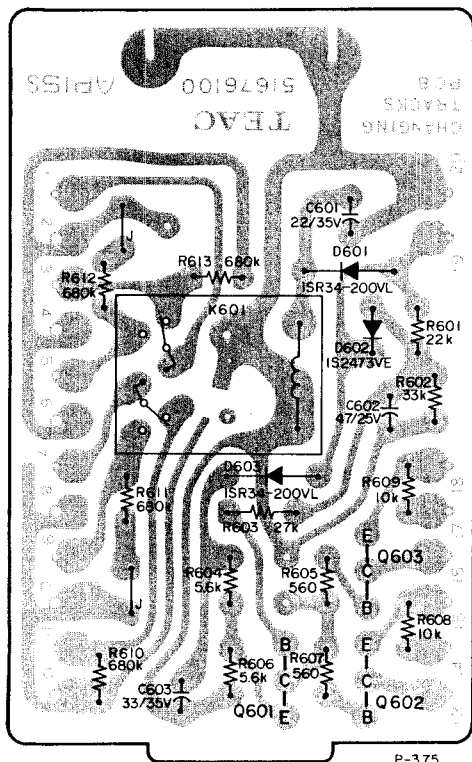

## 2-6. SWITCH MOUNTING PC BOARD

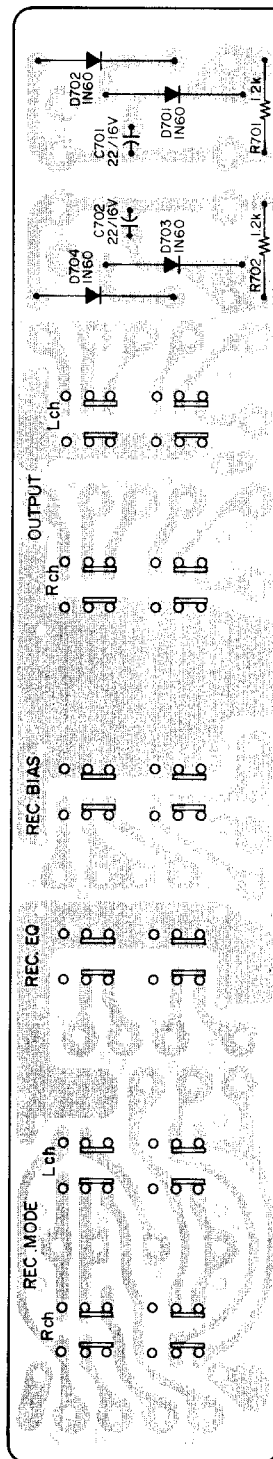

## 2-7. CONTROL PC BOARD

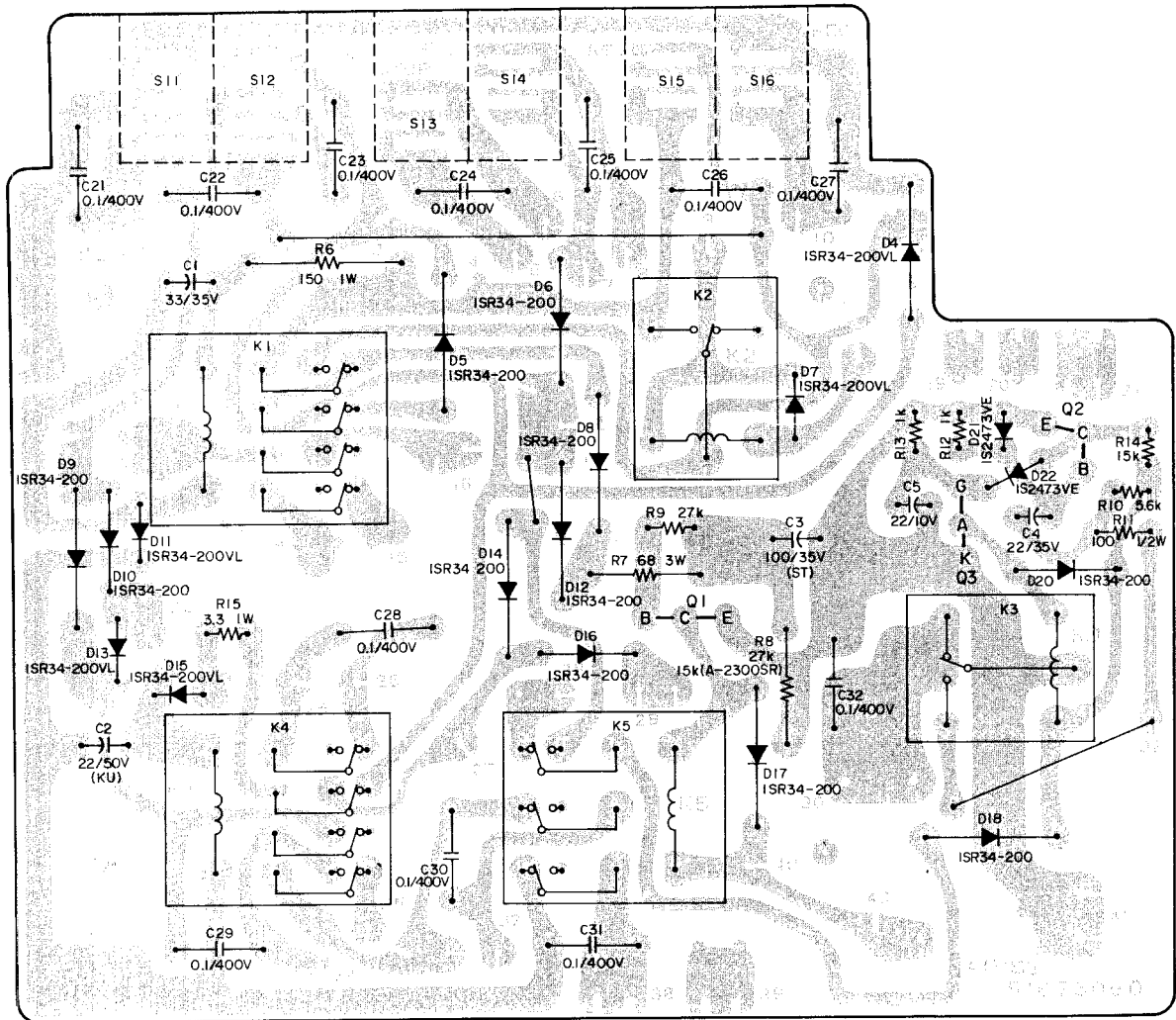

P-377

## 2-8. SENSING PC BOARD

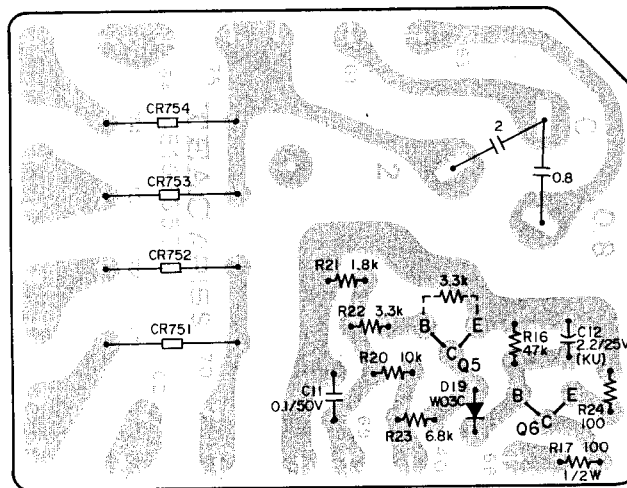

P-378



## 2-9. POWER SUPPLY PC BOARD

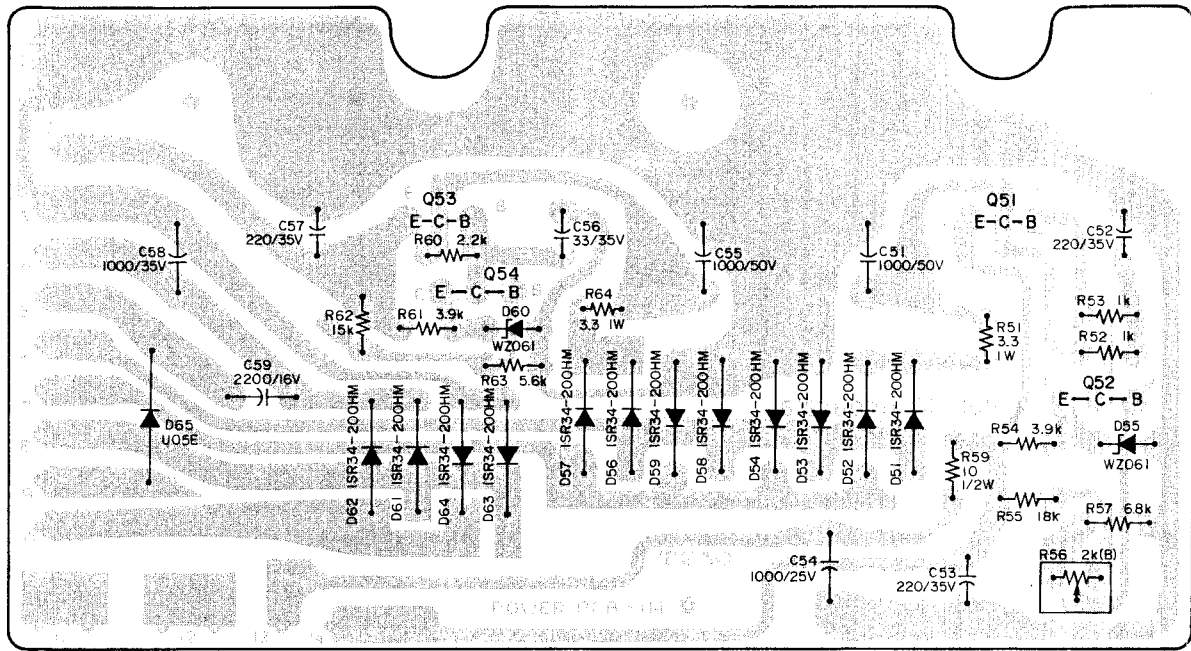

P-379

## 2-10. CONTROL RELAY PC BOARD

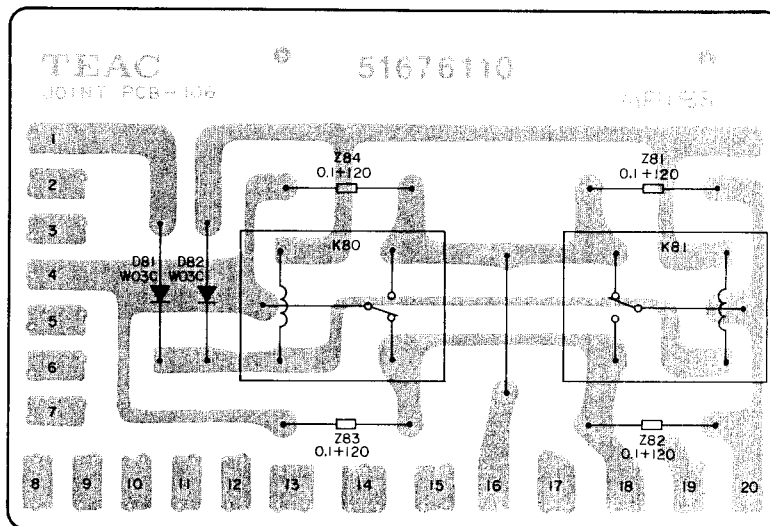

P-380

## 2-11. REEL MOTOR PC BOARD

### (A-3300SR)

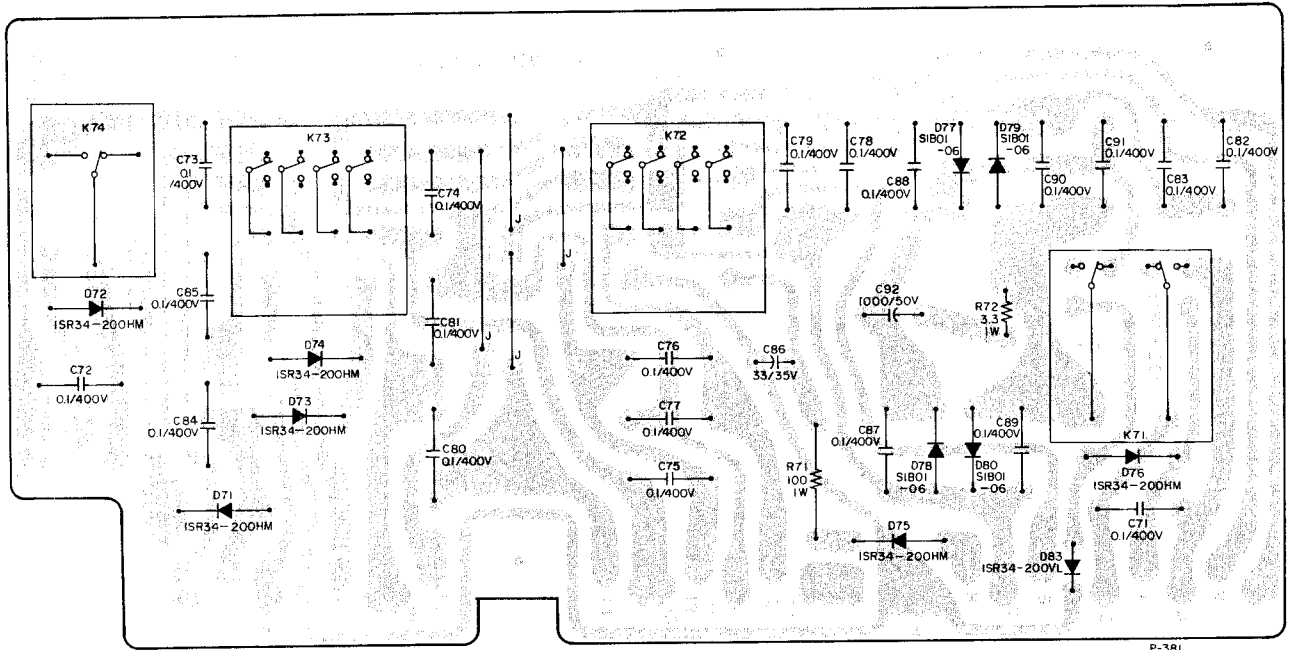

P-381

### (A-2300SR)

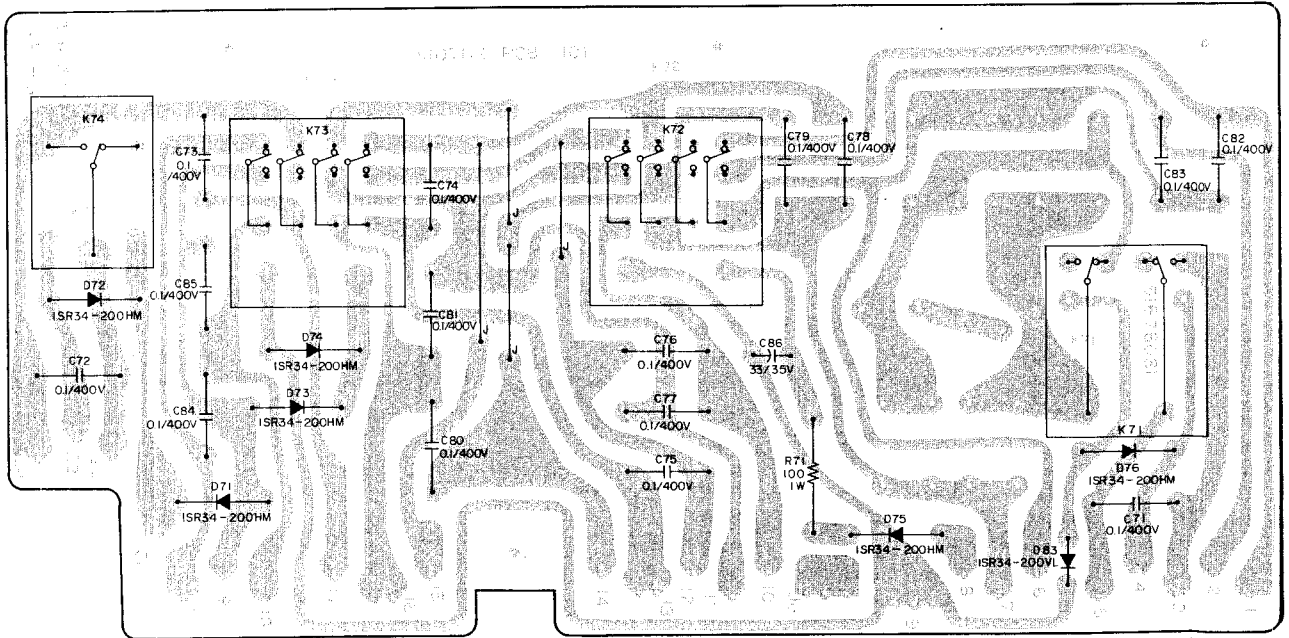

P-382

## 2. PC BOARD SECTION (Parts List)

### 2-1. EQ, MIC AMPL. PC BOARD

REF. NO.	PARTS NO.	DESCRIPTION
	51686820	PC Board Assy
	57676640	PC Board
<b>TRANSISTORS</b>		
Q101/Q104	50424340	2SC1000 (BL)
Q102/Q105	50423650	2SA494 (Y)
Q103/Q106	50424600	2SC828 (S)
Q107/Q108	50424340	2SC1000 (BL)
<b>CARBON RESISTORS</b>		
All resistors are rated $\pm 5\%$ tolerance, $\frac{1}{4}$ watt and of carbon type unless otherwise noted.		
R101/R120	50573400	270k ohm
R102/R121	51832920	1k ohm
R103/R122	51833341	56k ohm (SG)
R104/R123	51833341	56k ohm (SG)
R105/R124	51833320	47k ohm
R106/R125	51833301	39k ohm (SG)
R107/R126	51833181	12k ohm (SG)
R108/R127	50572660	220 ohm
R109/R128	51833280	33k ohm
R110/R129	51832940	1.2k ohm
R111/R130	51832740	180 ohm
R112/R131	51833160	10k ohm
R113/R132	51833100	5.6k ohm
R114/R133	51833480	220k ohm
R115/R134	51832940	1.2k ohm
R116/R135	50573400	270k ohm
R139	51818640	470 ohm Non Flammable
R140/R147	51832920	1k ohm
R141/R148	51833500	270k ohm
R142/R149	51833360	68k ohm
R143/R150	51833320	47k ohm
R144/R151	50572620	150 ohm
R145/R152	51833180	12k ohm
R146/R153	50573060	10k ohm
R154	51832940	1.2k ohm
<b>CAPACITORS</b>		
C101/C114	51700090	Tant. 10 mfd 16V
C102/C115	50554030	Elec. 47 mfd 6.3V
C103/C116	50547560	Dip. Mica 470 pfd 50V
C104/C117	51700820	Elec. 10 mfd 25V (LR)
C105/C118	50549740	Elec. 100 mfd 25V (KU)
C106/C119	50554230	Elec. 100 mfd. 6.3V
C107/C120	50543820	Dip. Mica 22 pfd 50V
C108/C121	50547560	Dip. Mica 470 pfd 50V
C109/C122	51700860	Elec. 1 mfd 50V (LR)
C110/C123	50548420	Mylar 0.015 mfd 50V
C127	50554170	Elec. 100 mfd 25V
C128/C132	50554050	Elec. 10 mfd 16V
C129/C133	50547560	Dip. Mica 470 pfd 50V
C130/C134	50554030	Elec. 47 mfd 6.3V
C131/C135	50554050	Elec. 10 mfd 16V
<b>VARIABLE RESISTORS</b>		
VR101/VR103	50533580	Semi-fixed, 6.8k ohm - B
VR102/VR104	50533540	Semi-fixed, 15k ohm - B

### 2-2. LINE, PHONE AMPL. PC BOARD

REF. NO.	PARTS NO.	DESCRIPTION
	51686650	PC Board Assy
	51676650	PC Board
<b>TRANSISTORS</b>		
Q201/Q204	50423870	2SC693 (G)
Q202/Q205	50424660	2SA564 (R)
Q203/Q206	50423830	2SC536 (F)
<b>CARBON RESISTORS</b>		
All resistors are rated $\pm 5\%$ tolerance and $\frac{1}{4}$ watt.		
R201/R220	51832920	1k ohm
R202/R221	51833360	68k ohm
R203/R222	51833320	47k ohm
R204/R223	51833340	56k ohm
R205/R224	51833240	22k ohm
R206/R225	51823160	10k ohm
R207/R226	51832860	560 ohm
R208/R227	51833340	56k ohm
R209/R228	51832860	560 ohm
R210/R229	51832680	100 ohm
R211/R230	51833080	4.7k ohm
R212/R231	51833240	22k ohm
R213/R232	51832920	1k ohm
R214/R233	51833260	27k ohm
R215/R234	51833380	82k ohm
R216/R235	51833180	12k ohm
R217/R236	51833040	3.3k ohm
R218/R237	51832860	560 ohm
R219/R238	51833440	150k ohm
R239	51818520	150 ohm Non Flammable
<b>CAPACITORS</b>		
C201/C214	51700860	Elec. 1 mfd 50V (LR)
C202/C215	50546562	Dip. Tant. 10 mfd 16V
C203/C216	50548320	Mylar 0.001 mfd 50V
C204/C217	50554050	Elec. 10 mfd 16V
C205/C218	50548020	Mylar 0.01 mfd 50V
C206/C219	50554170	Elec. 100 mfd 25V
C207/C220	50547440	Dip. Mica 100 pfd 50V
C208/C221	50554230	Elec. 100 mfd 6.3V
C209/C222	50543820	Dip. Mica 22 pfd 50V
C210/C223	51700820	Elec. 10 mfd 25V (LR)
C211/C224	50554050	Elec. 10 mfd 16V
C212/C225	50554260	Elec. 33 mfd 16V
C213/C226	50554030	Elec. 47 mfd 6.3V
C227	50554170	Elec. 100 mfd 25V
<b>VARIABLE RESISTORS</b>		
VR201/VR203	50533460	Semi-fixed, 4.7k ohm - B
VR202/VR204	50533520	Semi-fixed, 4.7k ohm - B
<b>COILS/TRANSFORMERS</b>		
L201/L202	50566640	Coil, Choke 220 $\mu$ H
T201/T202	50562141	Transformer, Output 3k ohm : 1 ohm

## 2-3. RECORD, METER AMPL. PC BOARD

REF. NO.	PARTS NO.	DESCRIPTION
	51686490	PC Board Assy
	50484103	PC Board
<b>TRANSISTORS</b>		
Q301/Q305	50423870	2SC693 (G)
Q302/Q306	50423650	2SA494 (Y)
Q303/Q307	50424600	2SC828 (S)
Q304/Q308	50424600	2SC828 (S)
<b>CARBON RESISTORS</b>		
All resistors are rated $\pm 5\%$ tolerance and $\frac{1}{4}$ watt.		
R301/R329	50570820	1k ohm
R302/R330	50571400	270k ohm
R303/R331	50571360	180k ohm
R304/R332	50571200	39k ohm
R305/R333	50571080	12k ohm
R306/R334	50570700	330 ohm
R307	50571100	15k ohm
R308/R335	50571220	47k ohm
R309/R336	50571300	100k ohm
R310/R337	50570720	390 ohm
R311/R338	50570540	68 ohm
R312/R339	50570940	3.3k ohm
R313/R340	50571360	180k ohm
R314/R341	50571320	120k ohm
R315/R342	50571020	6.8k ohm
R316/R343	50570980	4.7k ohm
R317/R344	50571220	47k ohm
R318/R345	50571140	22k ohm
R319/R346	50570900	2.2k ohm
R320/R347	50570500	47 ohm
R321/R348	50570840	1.2k ohm
R322/R349	50570580	100 ohm
R323/R350	50571260	68k ohm
R324/R351	50571100	15k ohm
R325/R352	50570960	3.9k ohm
R326/R353	50570820	1k ohm
R327/R354	50570520	56 ohm
R328	51818440	68 ohm Non Flammable
<b>CAPACITORS</b>		
C301/C320	50554040	Elec. 10 mfd 25V
C302/C321	50548320	Mylar 0.001 mfd 50V
C303/C322	50554570	Elec. 100 mfd 10V
C304	50554170	Elec. 100 mfd 25V
C306/C324	50549270	Mylar 0.082 mfd 50V 5%
C307/C325	50543820	Dip. Mica 22 pfd 50V
C308/C326	50554910	Elec. 220 mfd 10V
C309/C327	51700820	Elec. 10 mfd 25V (LR)
C310/C328	50549240	Mylar 0.039 mfd 50V 5%
C311/C329	50554040	Elec. 10 mfd 25V
C312/C330	50546621	Dip. Tant. 6.8 mfd 25V
C313/C331	50543440	Polyst. 820 pfd 50V
C314/C332	50548870	Mylar 0.015 mfd 50V 5%
C315/C333	50548240	Mylar 0.033 mfd 50V
C316/C334	50554670	Elec. 1 mfd 25V
C317/C335	50554220	Elec. 3.3 mfd 25V
C318/C336	50554230	Elec. 100 mfd 6.3V

REF. NO.	PARTS NO.	DESCRIPTION
C319/C337	50548120	Mylar 0.0015 mfd 50V
C338	50554180	Elec. 220 mfd 25V
C350/C351	50547420	Dip. Mica 47 pfd 50V
C501/C502	50548130	Mylar 0.0047 mfd 50V
<b>VARIABLE RESISTORS</b>		
VR301/VR304	50533960	Semi-fixed, 33k ohm - B
VR302/VR305	50533490	Semi-fixed, 100k ohm - B
VR303/VR306	50533520	Semi-fixed, 47k ohm - B
<b>COILS</b>		
L301/L303	50566370	Record EQ, 2.4 ~ 4.2 mH
L302/L304	50566300	Trap, 3 mH

## 2-4. BIAS OSCILLATOR PC BOARD

REF. NO.	PARTS NO.	DESCRIPTION
	50490873	PC Board Assy
	50484110	PC Board
<b>TRANSISTORS</b>		
Q401, Q402	50424750	2SC1384 (Q~S)
	50333040	Heat Sink
<b>DIODE</b>		
D19	50422560	SIB01-02
<b>RELAY</b>		
K401	50610690	MY4-0 DC24V
<b>RESISTORS</b>		
R401	50526390	Wire Wound 56 ohm 1W
R402	50574900	Carbon 2.2k ohm 1/2W
R403	50570720	Carbon 390k ohm 1/4W
R404, R405	50574980	Carbon 4.7k ohm 1/2W
R406, R407	50574460	Carbon 33 ohm 1/2W
R408	50574500	Carbon 47 ohm 1/2W
<b>CAPACITORS</b>		
C401	50554380	Elec. 220 mfd 35V
C402, C403	50548910	Mylar 0.0047 mfd 50V 5%
C404	50548870	Mylar 0.015 mfd 50V 5%
C405	50544040	Mica 4200 pfd 300V
C406	50549920	Meta. Mylar 0.1 mfd 400V
C407	50556820	Elec. 3.3 mfd 50V
C408	51700160	Mylar 0.033 mfd 150V

## 2-6. SWITCH MOUNTING PC BOARD

REF. NO.	PARTS NO.	DESCRIPTION
<b>TRIMMER CAPACITORS</b>		
VR401, VC402	50547070	MAX. 80 pfd
VC403, VC404	50547070	MAX. 80 pfd
<b>COILS/TRANSFORMER</b>		
L401	50566581	Dummy Load, 3 mH
T401	50563550	Oscillator

## 2-5. HEAD SELECT PC BOARD

REF. NO.	PARTS NO.	DESCRIPTION
	51686100	PC Board Assy
	51676100	PC Board
<b>TRANSISTORS</b>		
Q601	50424210	2SA666I (S)
Q602, Q603	50424860	2SC536 (F)
<b>DIODES</b>		
D601	51430890	W03C
D602	50425170	1S2473VE
D603	51431160	1SR34 - 200VL
<b>CARBON RESISTORS</b>		
All resistors are rated $\pm 5\%$ tolerance and $\frac{1}{4}$ watt.		
R601	50571140	22k ohm
R602	50571180	33k ohm
R603	50571160	27k ohm
R604	50571000	5.6k ohm
R605	50570760	560 ohm
R606	50571000	5.6k ohm
R607	50570760	560 ohm
R608, R609	50571060	10k ohm
R610~R613	50571500	680k ohm
<b>CAPACITORS</b>		
C601	50554900	Elec. 22 mfd 35V
C602	50554490	Elec. 47 mfd 25V
C603	50554750	Elec. 33 mfd 35V
<b>RELAY</b>		
	50611210	MH2ZPG

REF. NO.	PARTS NO.	DESCRIPTION
	51683310	PC Board Assy
	51673310	PC Board
D701~D704	50422130	Diode, 1N60
D706, D707	51430890	Diode, W03C
R701, R702	51812840	Resistor, Carbon 1.2k ohm $\frac{1}{4}$ W 5%
C701, C702	50554880	Capacitor, Elec. 22 mfd 16V
	51812090	Jumper, JPW02
	51320230	Switch, Lever 4PDT (4 used)
	51320240	Switch, Lever 4PDT (2 used)

## 2-7. CONTROL PC BOARD

REF. NO.	PARTS NO.	DESCRIPTION
	51686390	PC Board Assy (A-3300SR)
	51686060	PC Board Assy (A-2300SR)
	51676060	PC Board
<b>TRANSISTORS</b>		
Q1	50424620	2SD235 (Y)
Q2	50424860	2SC536 (G)
<b>THYRISTOR</b>		
Q3	50428040	FOR2B41
<b>DIODES</b>		
D4~D18	51431160	1SR34-200VL
D20	51431160	1SR34-200VL
D21, D22	50425170	1S2473VE
<b>RELAYS</b>		
K1	50611380	MY4-02 DC24V
K2, K3	50611340	LC1-N DC24V
K4	50611380	MY4-02 DC24V
K5	50611120	MY3-0 DC24V
<b>RESISTORS</b>		
All resistors are rated $\pm 5\%$ tolerance, $\frac{1}{4}$ watt and of carbon type unless otherwise noted.		
R6	50526280	Wire Wound 150 ohm 1W
R7	51807540	Wire Wound 68 ohm 3W
R8	50571160	27k ohm (A-3300SR)
	50571100	15k ohm (A-2300SR)
R9	50571160	27k ohm
R10	50571000	5.6k ohm

## 2-9. POWER SUPPLY PC BOARD

REF. NO.	PARTS NO.	DESCRIPTION
R11	50574580	100 ohm 1/2W
R12, R13	50570820	1k ohm
R14	50571100	15k ohm
R15	50525440	Wire Wound 3.3 ohm 1W
<b>CAPACITORS</b>		
C1	50554750	Elec. 33 mfd 35V
C2	51700580	Elec. 22 mfd 50V (KU)
C3	51703050	Elec. 100 mfd 35V
C4	50554900	Elec. 22 mfd 35V
C5	50554720	Elec. 22 mfd 10V
C21~C32	50549920	Metal Film 0.1 mfd 400V
<b>MISCELLANEOUS</b>		
S11, S12	50446560	Micro Switch, VV-15-1A
S13	50446570	Micro Switch, VV-15-2A
S14~S16	50446580	Micro Switch, VV-15-3A

## 2-8. SENSING PC BOARD

REF. NO.	PARTS NO.	DESCRIPTION
	51686180	PC Board Assy
	51673531	PC Board
<b>TRANSISTORS</b>		
Q5	50423510	2SC733 (Y)
Q6	50424750	2SC1384 (Q)
<b>DIODE</b>		
D19	51431160	1SR34-200VL
<b>CARBON RESISTORS</b>		
All resistors are rated $\pm 5\%$ tolerance and 1/4 watt unless otherwise noted.		
R16	50571220	47k ohm
R17	50574580	100 ohm 1/2W
R20	50573060	10k ohm
R21	50570880	1.8k ohm
R22	50570940	3.3k ohm
R23	50571020	6.8k ohm
R24	50570580	100 ohm
R25	50570940	3.3k ohm
<b>CAPACITORS</b>		
C11	50548040	Mylar 0.1 mfd 50V
C12	50549670	Elec. 2.2 mfd 25V (KU)
<b>MISCELLANEOUS</b>		
CR751~CR754	50529050	Spark Killer, 0.1 mfd + 120 ohm 400V

REF. NO.	PARTS NO.	DESCRIPTION
	51686070	PC Board Assy
	51676070	PC Board
<b>TRANSISTORS</b>		
Q51	50425290	2SD389 (P)
Q52	50423510	2SC733 (Y)
Q53	50425290	2SC389 (P)
Q54	50423510	2SC733 (Y)
<b>DIODES</b>		
D51~D54	51431130	1SR34-200HM
D55	50425140	Zener, WZ061
D56~D59	51431130	1SR34-200HM
D60	50425140	Zener, WZ061
D61~D64	51431130	1SR34-200HM
D65	51430180	U05E

### RESISTORS

All resistors are rated  $\pm 5\%$  tolerance, 1/4 watt and of carbon type unless otherwise noted.

R51	50525440	Wire Wound 3.3 ohm 1W
R52, R53	50570820	1k ohm
R54	50570960	3.9k ohm
R55	50571120	18k ohm
R57	50571020	6.8k ohm
R59	50574340	10 ohm
R60	50570900	2.2k ohm
R61	50570960	3.9k ohm
R62	50571100	15k ohm
R63	50571000	5.6k ohm
R64	50525440	Wire Wound 3.3 ohm 1W

### CAPACITORS

C51	50555850	Elec. 1000 mfd 50V
C52, C53	50554380	Elec. 220 mfd 35V
C54	50555580	Elec. 2200 mfd 25V
C55	50555850	Elec. 1000 mfd 50V
C56	50554750	Elec. 33 mfd 35V
C57	50554380	Elec. 220 mfd 35V
C58	51700110	Elec. 1000 mfd 35V
C59	51703020	Elec. 2200 mfd 16V

### VARIABLE RESISTOR

R56	51501520	Semi-fixed, 2k ohm
-----	----------	--------------------

## 2-10. CONTROL RELAY PC BOARD

REF. NO.	PARTS NO.	DESCRIPTION
	51686110	PC Board Assy
	51676110	PC Board
D81, D82	51431100	Diode, 1SR34-200
K80, K81	50611350	Relay, LC1-N-JT DC 24V
Z81~Z84	50529050	Spark Killer, 0.1 mfd + 120 ohm 400V
	51812090	Jumper, JPW02

## 2-11. REEL MOTOR PC BOARD

REF. NO.	PARTS NO.	DESCRIPTION
	51686090	PC Board Assy (A-3300SR)
	51686081	PC Board Assy (A-2300SR)
	51676081	PC Board
<b>DIODES</b>		
D71~D76	51431130	1SR34-200HM
D77~D80	50422570	SIB01-06 (A-3300SR)
D83	51431160	1SR34-200VL
<b>RELAYS</b>		
K71	50611310	LC2-N DC24V
K72, K73	50611380	MY4-02 DC24V
K74	50611340	LC1-N DC24V
<b>RESISTORS</b>		
R71	50526290	Wire Wound 100 ohm 1W
R72	50525440	Wire Wound 3.3 ohm 1W (A-3300SR)
<b>CAPACITORS</b>		
C71~C85	50549920	Metal Film 0.1 mfd 400V
C86	50554750	Elec. 33 mfd 35V
C87~C91	50549920	Metal Film 0.1 mfd 400V (A-3300SR)
C92	50555850	Elec. 1000 mfd 50V (A-3300SR)
<b>MISCELLANEOUS</b>		
	51812090	Jumper, JPW02

(Continued from page-3)

REF. NO.	PARTS NO.	DESCRIPTION	REMARKS
1 - 64	50522480	Resistor, Wire Wound 20 ohm 20H	GENERAL EXPORT U.S.A., CANADA
1 - 65	*50113412	Panel, Side; Left	
1 - 66	55430080	Sideboard, B	
1 - 67	*50235312	Angle, Rear Cover	
1 - 68	55530320	Cover, Rear	
	55031390	Cover Assy, Rear	
1 - 69	50277980	Leg, Case	
1 - 70	*55043351	Cover Assy, Bottom	
1 - 71	55030241	Lever Assy, Cue	

(Continued from page-7)

REF. NO.	PARTS NO.	DESCRIPTION	REMARKS
3 - 58	*51686500	PC Board Assy, FUSE	U.S.A., CANADA
	51676420	PC Board	Part of 3-58
	50412370	Holder, Fuse	Part of 3-58
3 - 59	50411440	Fuse, 2A	Part of 3-58
3 - 60	50411450	Fuse, 1A	Part of 3-58
3 - 61	51421130	Fuse, 1.6A	Part of 3-58
3 - 62	51421140	Fuse, 2.5A	Part of 3-58
3 - 63	55344560	Cover, Fuse PC Board	U.S.A., CANADA

(Continued from page-9)

REF. NO.	PARTS NO.	DESCRIPTION	REMARKS
4 - 58	*51686510	PC Board Assy, FUSE	U.S.A., CANADA
	51676420	PC Board	Part of 4-58
	50412370	Holder, Fuse	Part of 4-58
4 - 59	50411440	Fuse, 2A	Part of 4-58
4 - 60	50411450	Fuse, 1A	Part of 4-58
4 - 61	51421130	Fuse, 1.6A	Part of 4-58
4 - 62	51421140	Fuse, 2.5A	Part of 4-58
4 - 63	55344560	Cover, Fuse PC Board	U.S.A., CANADA



## TRANSISTOR SUBSTITUTION CHART

TYPE	PARTS NO.	REPLACEMENT	PARTS NO.
2SC1000 (BL)	50424340	2SC1345 (E)	50424710
2SA494 (Y)	50423650	2SA750 (E)	51450380
2SC828 (S)	50424600	2SC536 (G) 2SC945L (K)	50424860 51450360
2SC693 (G)	50423870	2SC900 (E)	50424940
2SA564 (R)	50424660	2SA750 (E)	51450380
2SC536 (F)	50423830	2SC536 (G)	50424860
2SC1384 (Q~S)	50424750	2SD571 (L)	51450590
2SD288 (K)	50425270	2SD389 (P)	50425290
2SC1318 (R) or (S)	50426250	2SC1317 (R) or (S)	50424670

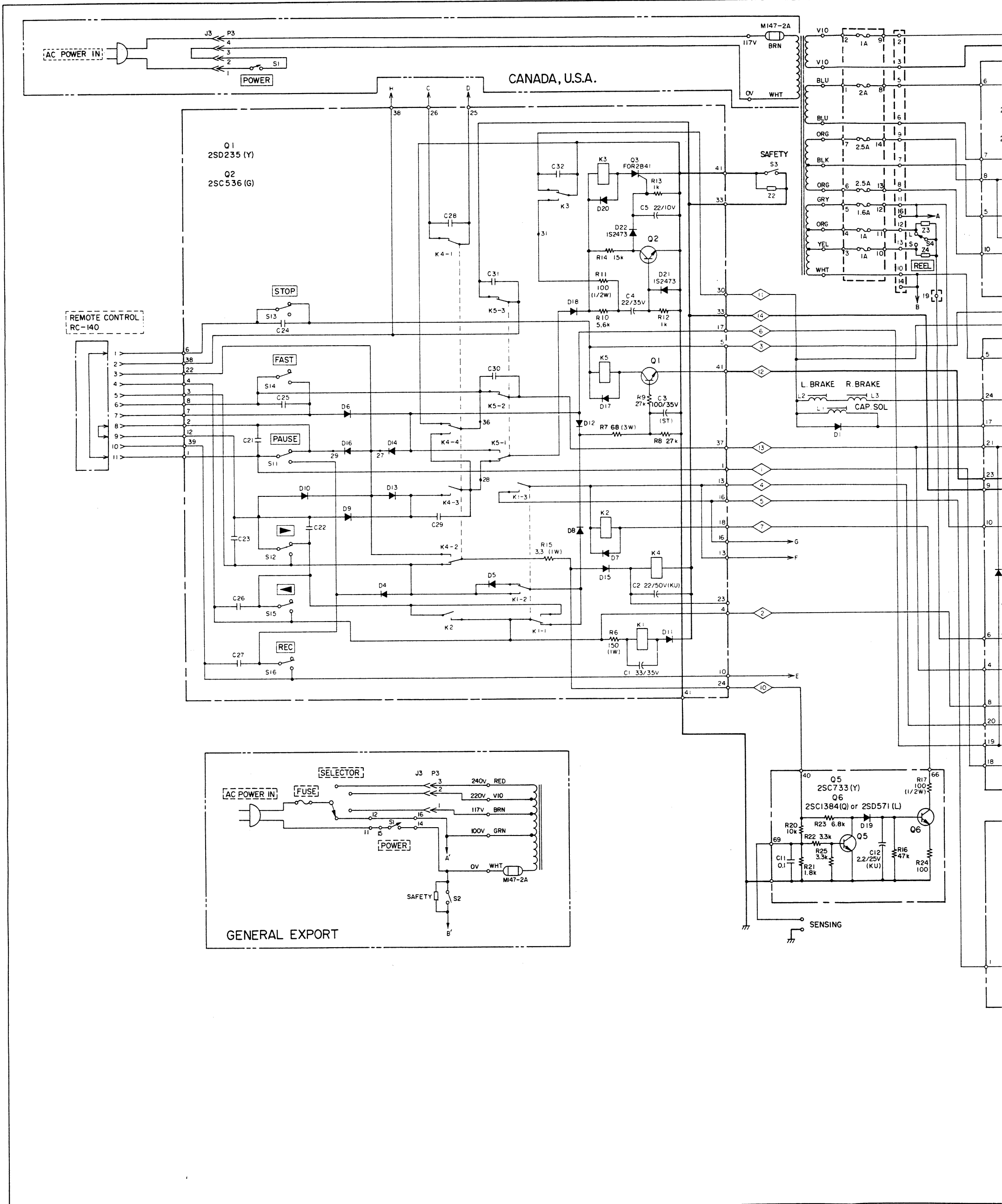

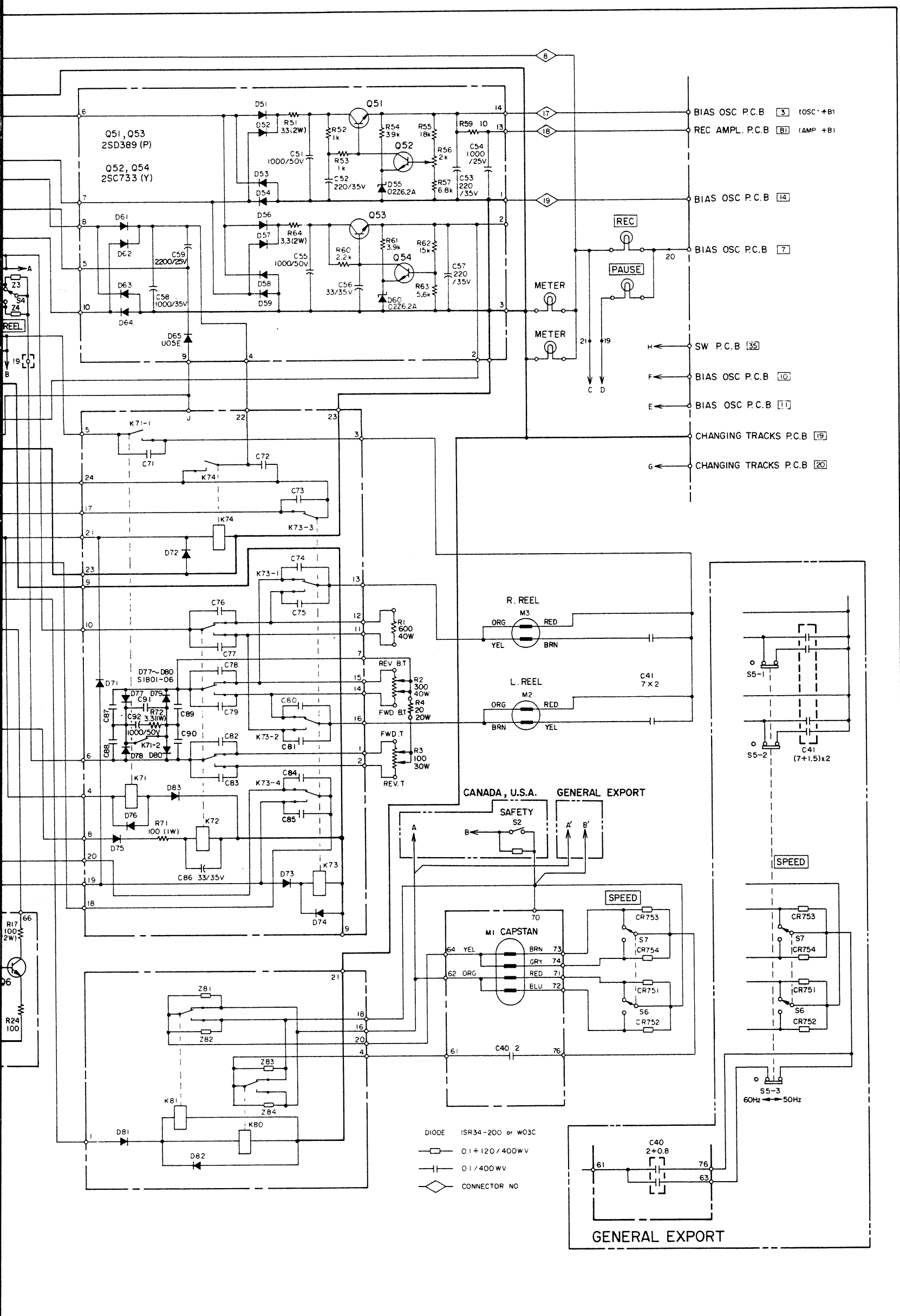

NOTES  
 1. ALL RESISTORS ARE 1/4 WATT, 5% UNLESS MARKED OTHERWISE.  
 RESISTOR VALUES ARE IN OHMS (k=1,000 OHMS, M=1,000,000 OHMS).  
 2. ALL CAPACITOR VALUES ARE IN MICROFARADS (p=PICOFARADS).

6			
5			
4			
3			
2	04-78	E-1123	
1	03-78		
REVISION	DATE	CHANGE NO.	

S-208  
**TAPE TRANSPORT**  
 MODEL NO. **A-3300SR** SHEET NO.   
**TEAC CORPORATION**

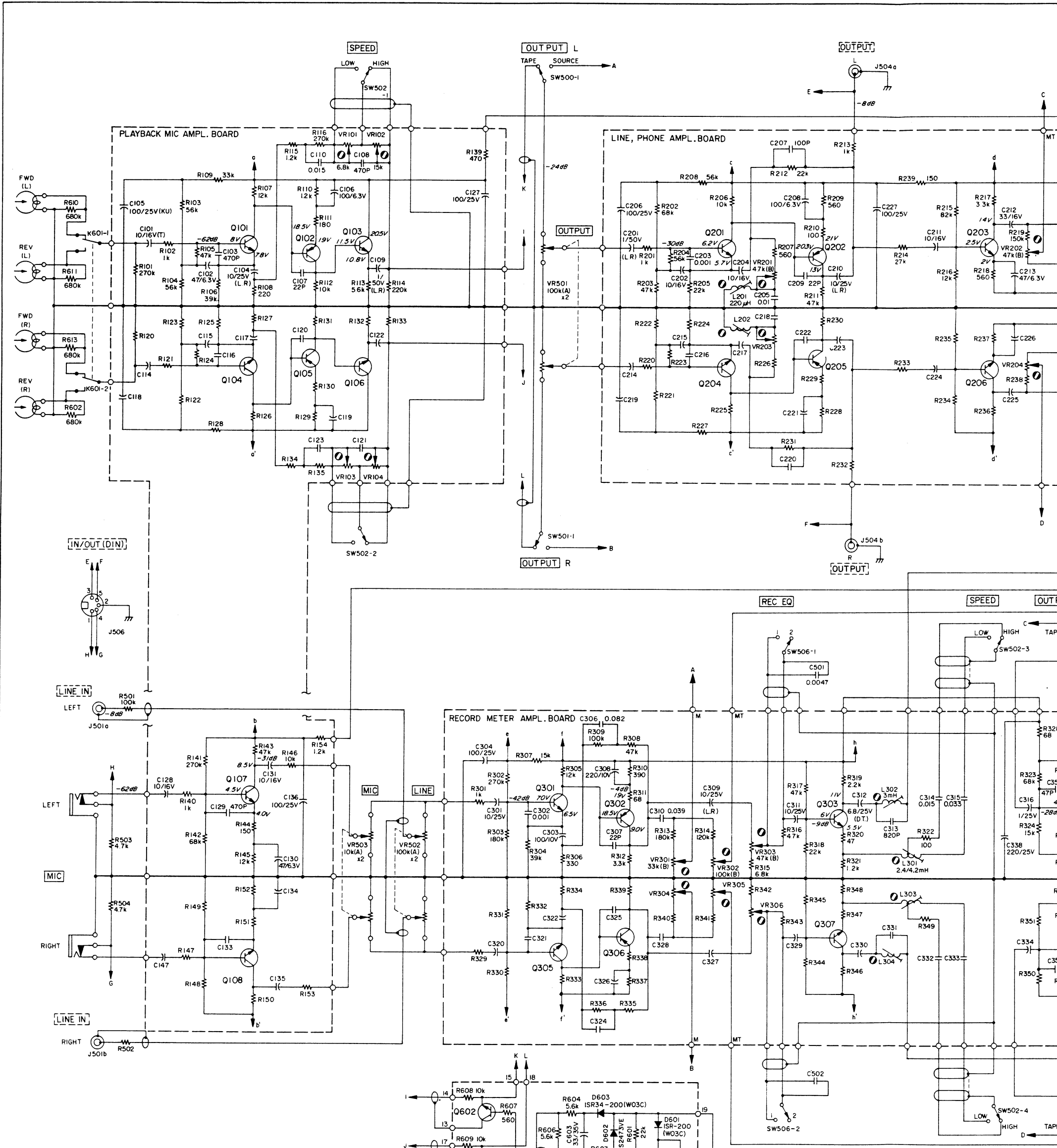

CIRCUIT REF. NO.	DESCRIPTION	CIRCUIT REF. NO.	DESCRIPTION
Q101/Q104	2SC1000(BL)	2SC1345(E)	
Q102/Q105	2SA494(Y)	2SA750(E)	
Q103/Q106	2SC828(S)	2SC536(G)	
Q107/Q108	2SC1000(BL)	2SC1345(E)	
Q201/Q204	2SC693(G)	2SC900(E)	
Q202/Q205	2SA564(R)	2SA750(E)	
Q203/Q206	2SC536(F) or (G)		
Q301/Q305	2SC693(G)	2SC900(E)	
Q302/Q306	2SA494(Y)	2SA750(E)	
Q303/Q307	2SC828(S)	2SC945L(K)	
Q304/Q308	2SC828(S)	2SC536(G)	
Q602/Q603	2SC536(G)		
Q601	2SA6661(S)		

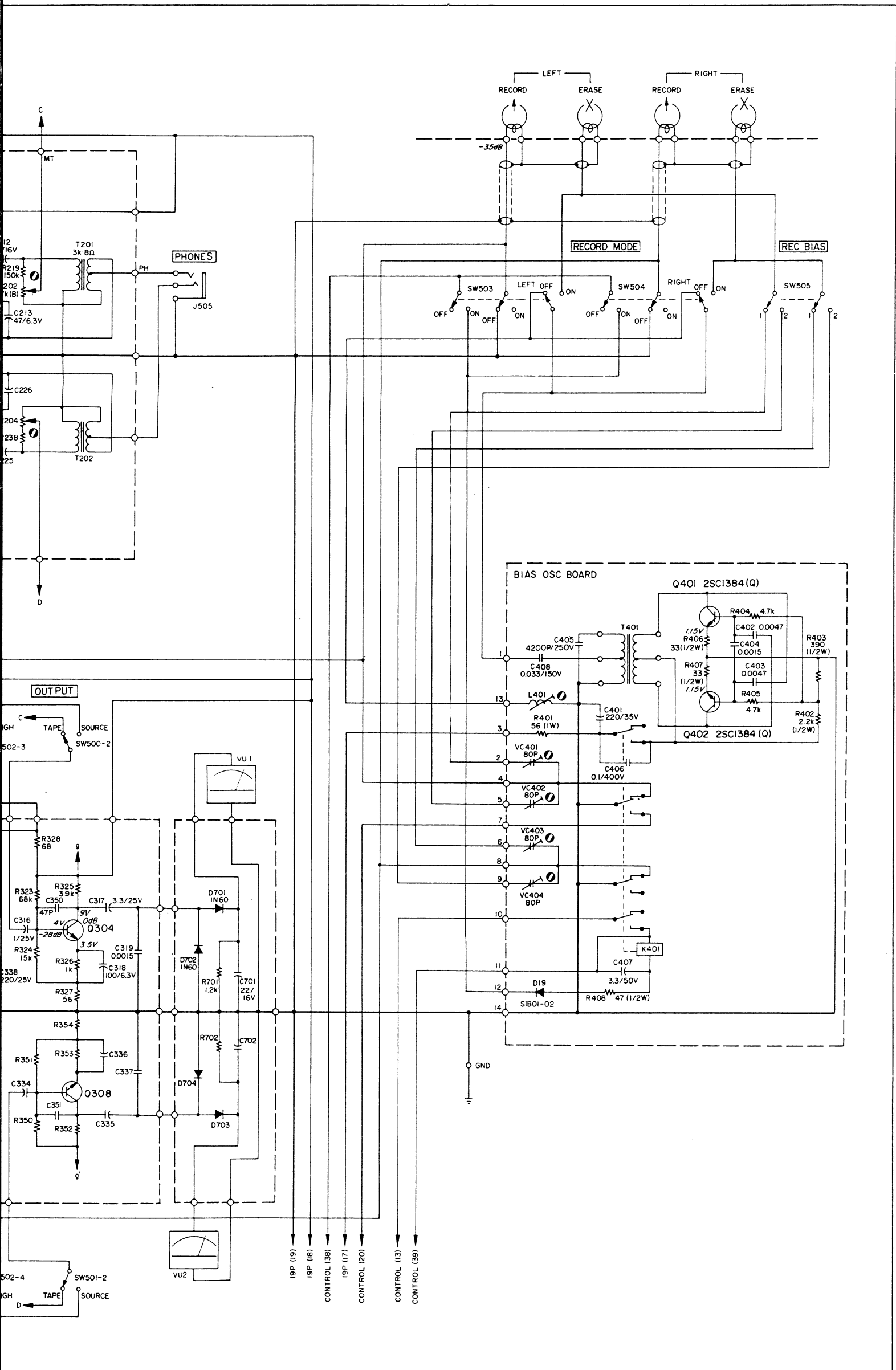

**NOTES**

1. ALL RESISTORS ARE 1/4 WATT, 5%, UNLESS MARKED OTHERWISE.
2. RESISTOR VALUES ARE IN OHMS (k=1,000 OHMS, M=1,000,000 OHMS).
3. ALL CAPACITOR VALUES ARE IN MICROFARADS (μ=PICOFARADS).
4. DC VOLTAGES WERE MEASURED DURING RECORD PAUSE MODE.
5. SIGNAL LEVELS (dB) WERE MEASURED WITH INPUT AND OUTPUT CONTROLS AT SPECIFIED POSITION.
6. READING IN dB REFERENCED TO 0dB=0.775V.

REVISION	DATE	CHANGE NO.
6		
5		
4		
3		
2	04-78	E-1123
1	02-78	

S-210

**PREAMPLIFIER**

MODEL NO. **A-3300SR** SHEET NO.   

**TEAC CORPORATION**

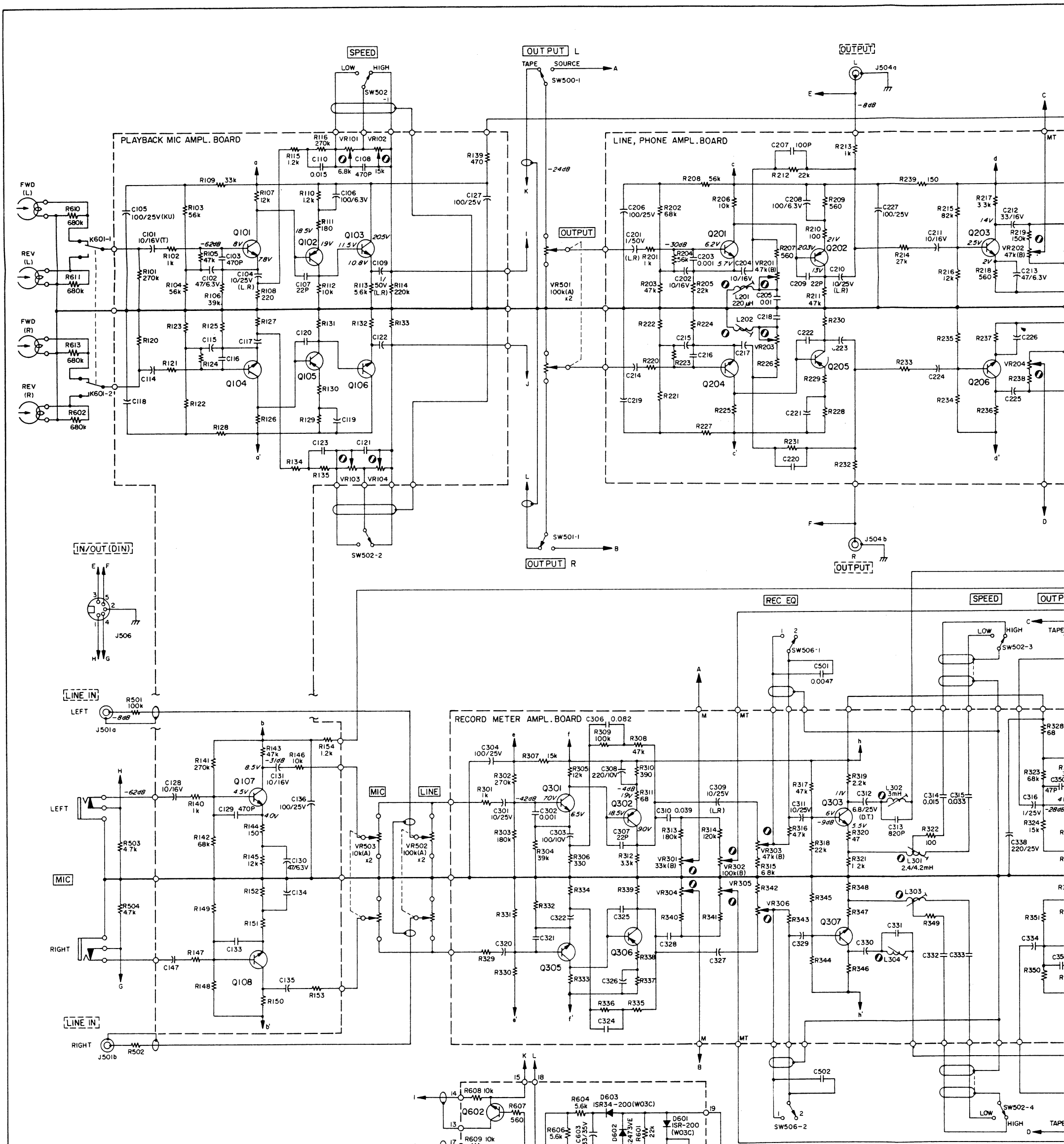

CIRCUIT REF. NO.	DESCRIPTION	CIRCUIT REF. NO.	DESCRIPTION
Q101 / Q104	2SC1000(BL) 2SC1345(E)	Q301 / Q305	2SC693(G) 2SC900(E)
Q102 / Q105	2SA494(Y) 2SA750(E)	Q302 / Q306	2SA494(Y) 2SA750(E)
Q103 / Q106	2SC828(S) 2SC536(G)	Q303 / Q307	2SC828(S) 2SC945L(K)
Q107 / Q108	2SC1000(BL) 2SC1345(E)	Q304 / Q308	2SC828(S) 2SC536(G)
Q201 / Q204	2SC693(G) 2SC900(E)	Q602 / Q603	2SC536(G)
Q202 / Q205	2SA564(R) 2SA750(E)	Q601	2SA6661(S)
Q203 / Q206	2SC536(F) or (G)		

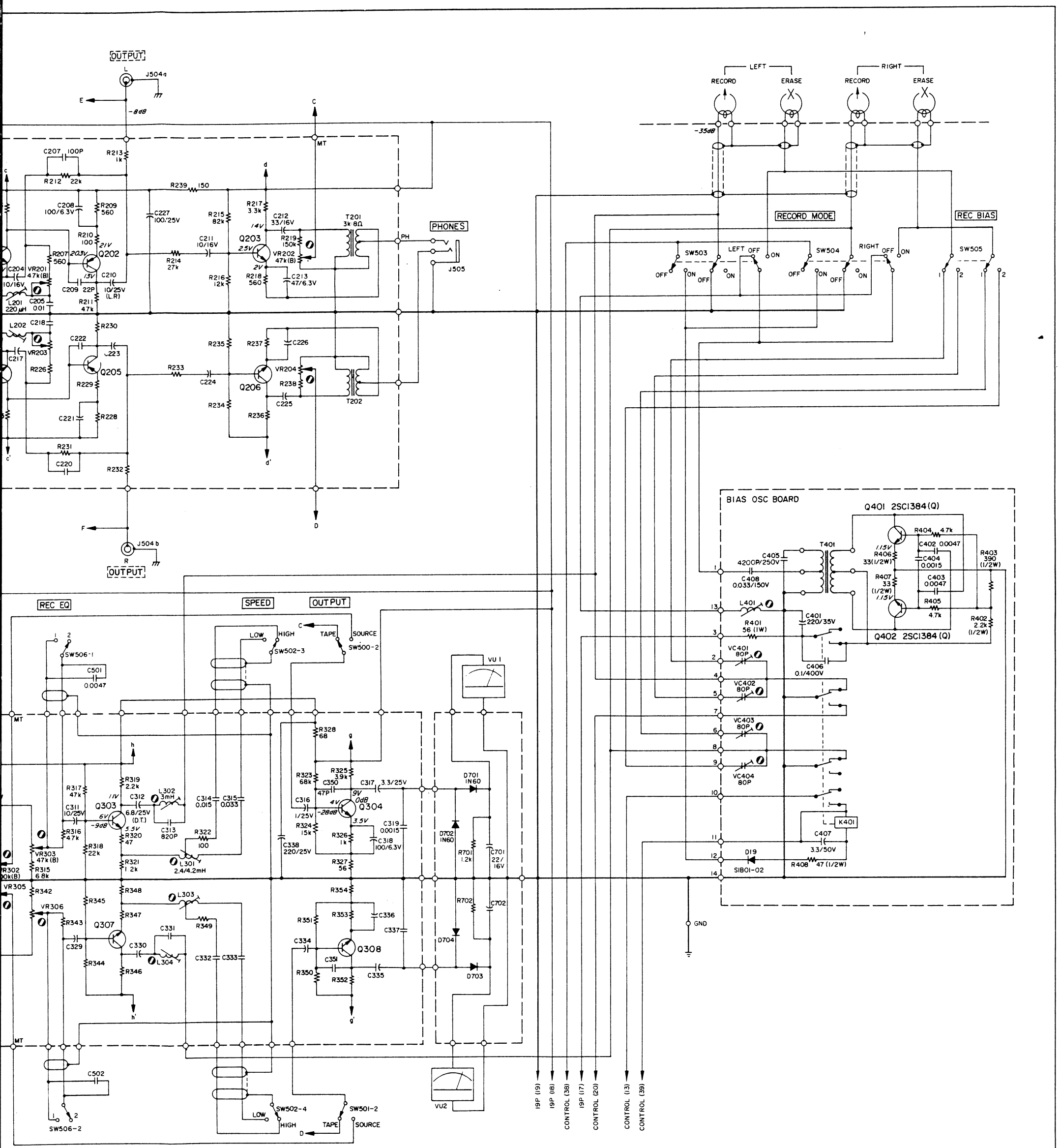

NOTES

1. ALL RESISTORS ARE 1/4 WATT, 5% UNLESS MARKED OTHERWISE.
2. RESISTOR VALUES ARE IN OHMS (k=1,000 OHMS, M=1,000,000 OHMS)
3. ALL CAPACITOR VALUES ARE IN MICROFARADS (p=PICOFARADS).
4. DC VOLTAGES WERE MEASURED DURING RECORD PAUSE MODE.
5. SIGNAL LEVELS (dB) WERE MEASURED WITH INPUT AND OUTPUT CONTROLS AT SPECIFIED POSITION.
6. READING IN dB REFERENCED TO 0dB=0.775V.

6				
5				
4				
3				
2	04-78	E-1123		
1	02-78			
REVISION	DATE	CHANGE NO.		

PREAMPLIFIER

MODEL NO. **A-2300SR** SHEET NO.

TEAC CORPORATION

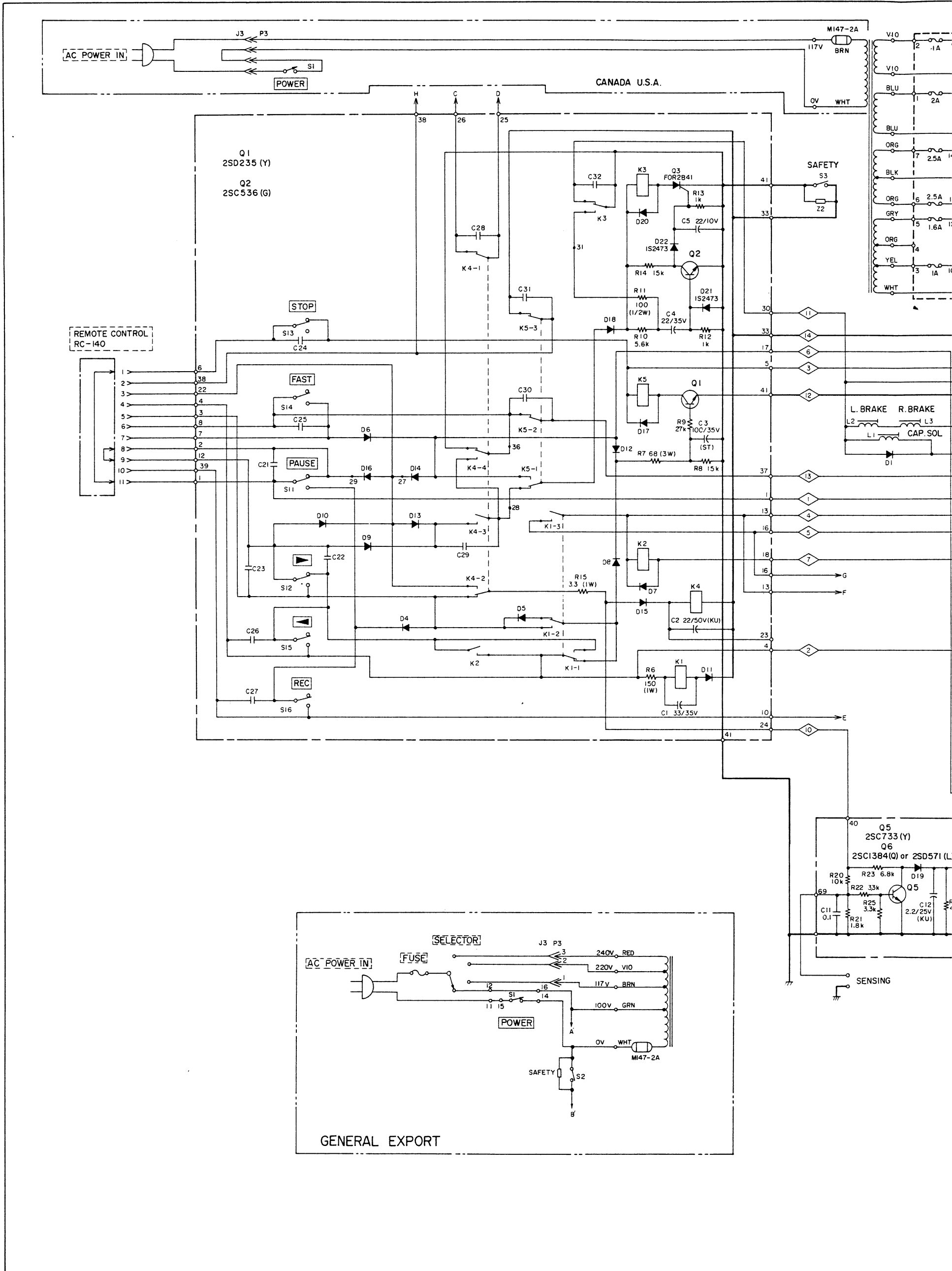



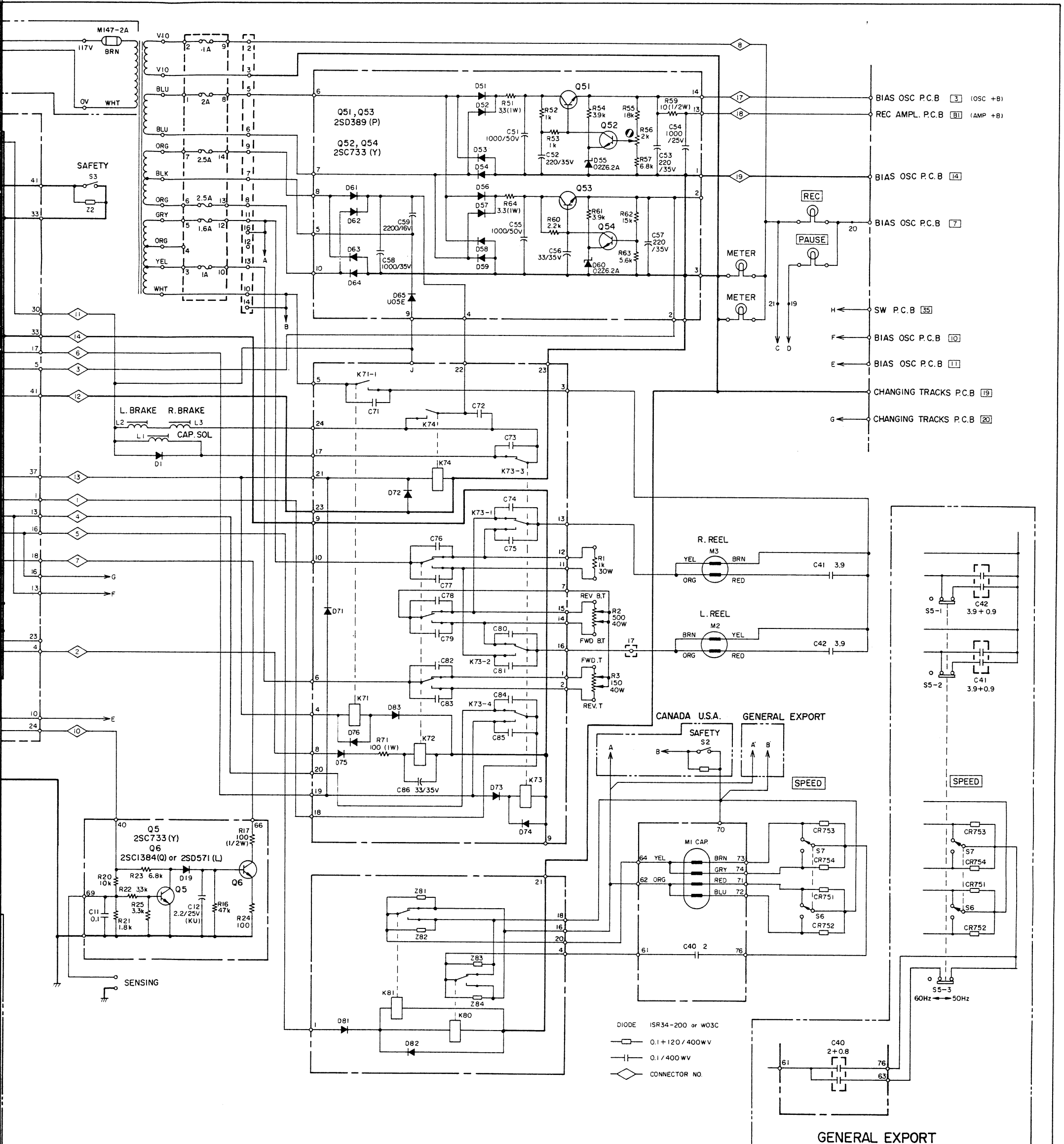

NOTES  
 1. ALL RESISTORS ARE 1/2 WATT, 5% UNLESS MARKED OTHERWISE.  
 RESISTOR VALUES ARE IN OHMS (K=1,000 OHMS, M=1,000,000 OHMS).  
 2. ALL CAPACITOR VALUES ARE IN MICROFARADS (P=PICOFARADS).

6		
5		
4		
3		
2	04-78	E-1123
1	02-78	
REVISION	DATE	CHANGE NO.

S-209

**TAPE TRANSPORT**

MODEL NO. **A-2300SR** SHEET NO.

**TEAC CORPORATION**

GENERAL EXPORT

# ASSEMBLING HARDWARE CODING LIST

All screws conform to ISO standards, and have crossrecessed heads, unless otherwise noted. ISO screws have the head inscribed with a point as in the figure to the right.

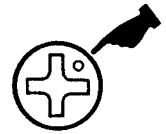

FOR EXAMPLE:

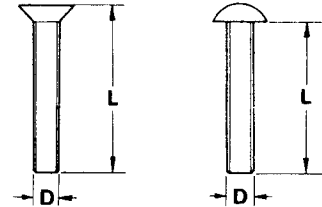
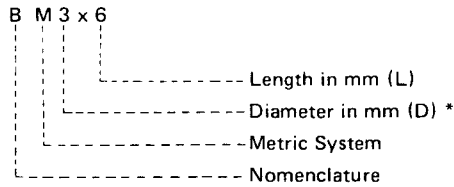

\* Inner dia. for washers and nuts

	Code	Name	Type		Code	Name	Type
MACHINE SCREW	<b>R</b>	Round Head Screw		TAPPING SCREW	<b>BTA</b>	Binding Head Tapping Screw(A Type)	
	<b>P</b>	Pan Head Screw			<b>BTB</b>	Binding Head Tapping Screw(B Type)	
	<b>T</b>	Stove Head Screw (Truss)			<b>RTA</b>	Round Head Tapping Screw(A Type)	
	<b>B</b>	Binding Head Screw			<b>RTB</b>	Round Head Tapping Screw(B Type)	
	<b>F</b>	Flat Countersunk Head Screw		SETSCREW	<b>SF</b>	Hex Socket Setscrew(Flat Point)	
	<b>O</b>	Oval Countersunk Head Screw			<b>SC</b>	Hex Socket Setscrew(Cup Point)	
WOOD SCREW	<b>RW</b>	Round Head Wood Screw		<b>SS</b>	Slotted Socket Setscrew(Flat Point)		
	<b>FW</b>	Flat Countersunk Wood Screw		WASHER	<b>E</b>	E-Ring (Retaining Washer)	
	<b>OW</b>	Oval Countersunk Wood Screw			<b>W</b>	Flat Washer (Plain)	
SEMS SCREW	<b>BSA</b>	Binding Head SEMS Screw(A Type)			<b>SW</b>	Lock Washer (Spring)	
	<b>BSB</b>	Binding Head SEMS Screw(B Type)			<b>LWI</b>	Lock Washer (Internal Teeth)	
	<b>BSF</b>	Binding Head SEMS Screw(F Type)			<b>LWE</b>	Lock Washer (External Teeth)	
	<b>PSA</b>	Pan Head SEMS Screw(A Type)		<b>TW</b>	Trim Washer (Countersunk)		
	<b>PSB</b>	Pan Head SEMS Screw(B Type)		NUT	<b>N</b>	Hex Nut	