

**Original**

**TEAC**

**A-4000 STEREO TAPE P L A Y E R**

**A-4010 STEREO TAPE RECORDER**

**SERVICE MANUAL**

**TEAC CORPORATION**

NOTICE!

The serial number of TEAC Model A-4000-Series starting at #8354 is hereby announced that the head alignment has been altered as the following Fig. 9-1 instead of previous Fig. 9.

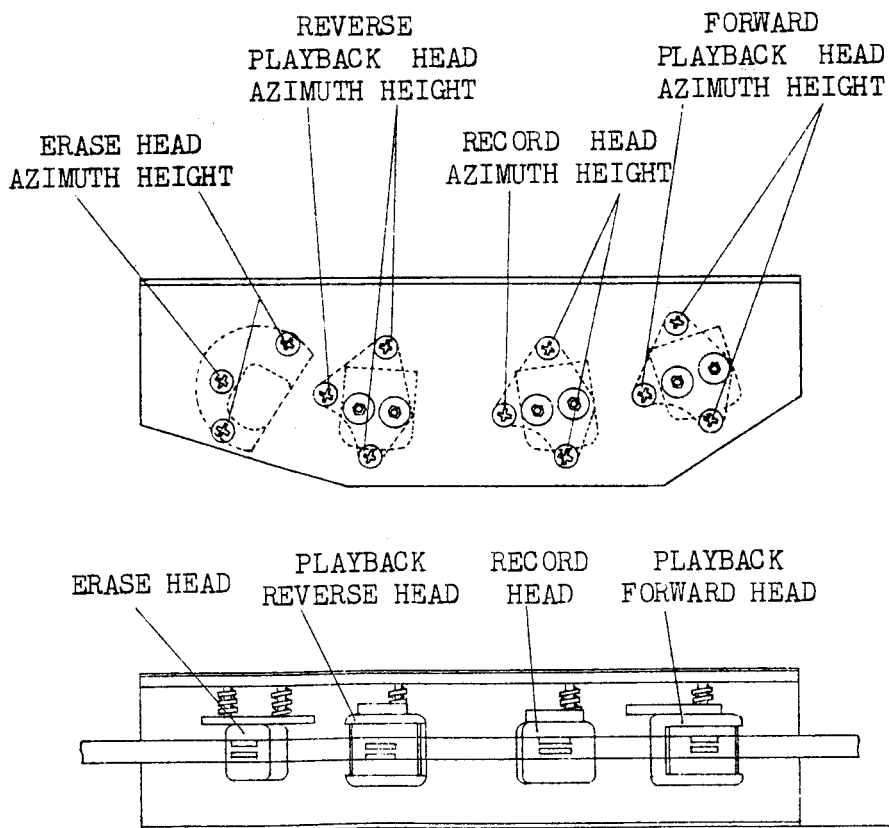

FIG. 9-1 HEAD ALIGNMENTS

TABLE OF CONTENTS

	Page
SPECIFICATIONS . . . . .	2
COMPONENT LOCATION . . . . .	3
DISASSEMBLY . . . . .	8
CONTROL BUTTONS . . . . .	12
MECHANISM ADJUSTMENTS . . . . .	14
ALIGNMENT AND PERFORMANCE CHECKS . . . . .	20
MAINTENANCE . . . . .	33
TROUBLE SHOOTING . . . . .	35
TRANSPORT MECHANISM WIRING DIAGRAM . . . . .	38
AMPLIFIER SCHEMATIC DIAGRAM . . . . .	39
RECORDING AMPLIFIER SCHEMATIC DIAGRAM . . . . .	40
EXPLODED VIEW AND PART NO. . . . .	41

## SPECIFICATIONS

Heads	Four, 4 track 2 channel Erase, Record, Forward playback and Reverse playback
Reel Size	7" maximum
Tape Speed	7 1/2 and 3 3/4 ips ( $\pm 0.5\%$ )
Motors	1-Dual speed hysteresis motor for capstan drive 2-Torque motors for reel turntables
Wow and Flutter	7 1/2 ips 0.12% 3 3/4 ips 0.15%
Fast Winding Time	Approximately 70 seconds for 1,200 feet
Frequency Response	7 1/2 ips 30 to 20,000 cps ( $\pm 3$ db 50 to 15,000 cps) 3 3/4 ips 40 to 12,000 cps ( $\pm 3$ db 50 to 7,500 cps)
Equalization	50 microseconds (NAB) for 7 1/2 ips 120 microseconds (EIA) for 3 3/4 ips
Signal to Noise Ratio	50 db at 7 1/2 ips (peak record level to unweighed)
Crosstalk	50 db channel to channel at 1,000 cps 40 db between adjacent tracks at 100 cps
Input (RA-40)	Microphone: 10,000 ohms, 0.25mV minimum Line: 100,000 ohms, 0.14V minimum
Output	12 volts for a load impedance 100,000 ohms or more
Power Requirements	100/117/200 VAC, 50 or 60 cps A-4000, A-4010L: 100 VA A-4010 : 110 VA
Dimensions	A-4000 : 17 1/4" x 13" x 9 1/2" A-4010L: 17 1/4" x 17 1/2" x 9 1/2" RA-40 : 17 1/4" x 5 5/16" x 9 1/2" A-4010 : 17 1/4" x 17 1/2" x 9 1/2"
Weight	A-4000 : 37 Lbs A-4010L: 40 Lbs RA-40 : 10 Lbs A-4010 : 48 Lbs

COMPONENT LOCATION

A-4000 PLAYER (DECK)

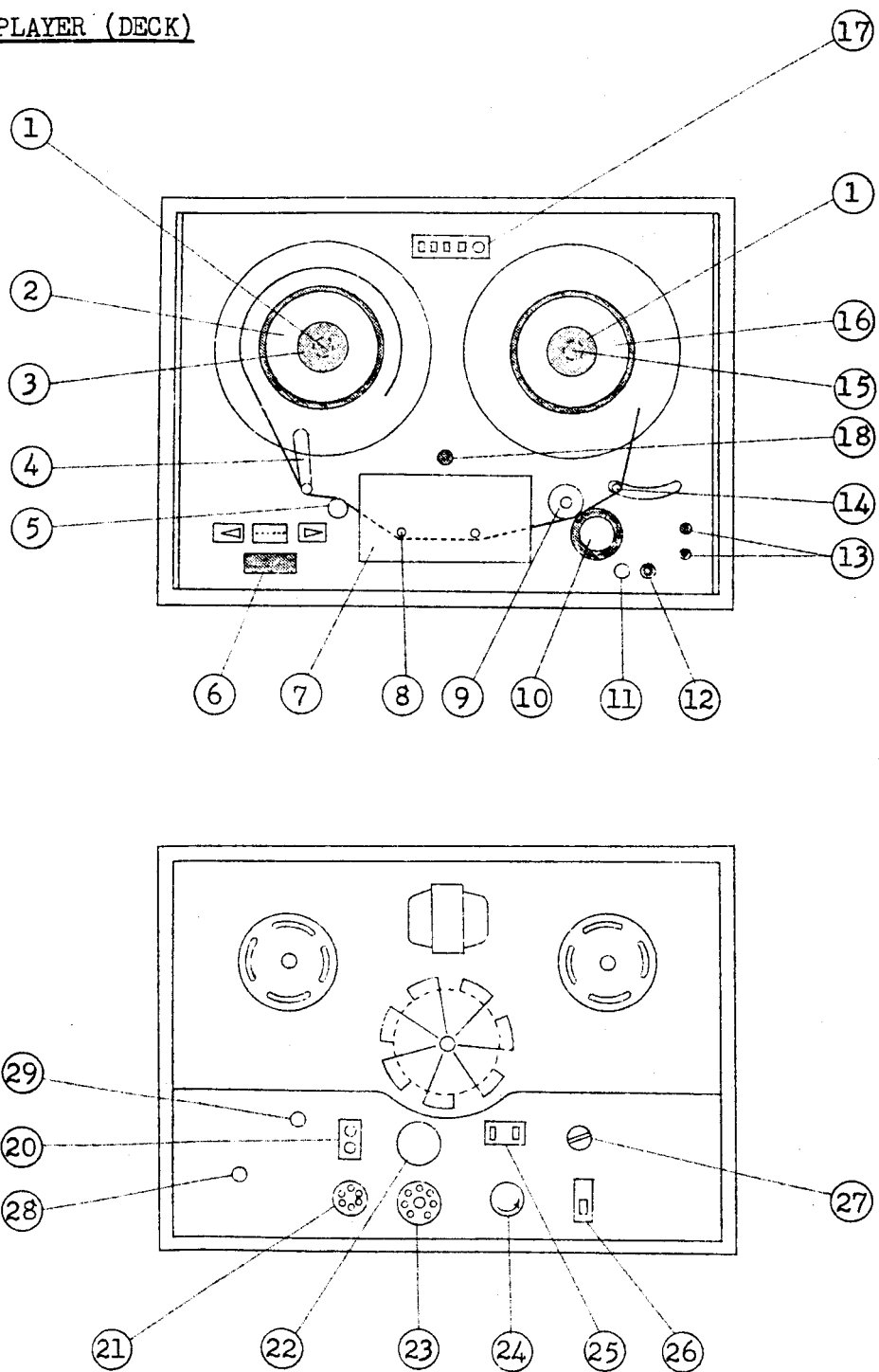





FIG. 1 A-4000 DECK

- ① Reel Holder
- ② Left Reel Turntable Shaft
- ③ Left Reel Turntable
- ④ Tension Arm
- ⑤ Sensing Post
  - permits automatic switch-over to reverse playback upon contact with the sensing foil on the tape.
- ⑥ Control Buttons
  - select tape operation.
  - Press  for forward playback.
  - Press  for reverse playback.
  - Press  and **FAST** for fast forward.
  - Press  and **FAST** for rewind.
- ⑦ Head Assembly
- ⑧ Tape Lifter
  - lifts tape from heads during fast wind operation.
- ⑨ Capstan
  - drives tape in recording and playback mode.
- ⑩ Pressure Roller  
(Pinch Roller)
  - drives tape with capstan.
- ⑪ Power Pilot Lamp
  - turns on when equipment is energized.
- ⑫ Power Switch
  - turns recorder on or off.
- ⑬ **TAPE SPEED**  
Tape Speed Selector Switch
  - selects tape speed and appropriate equalizer circuit.
  - 19** position: 7<sup>1</sup>/<sub>2</sub> ips (19 cm/s)
  - 9.5** position: 3<sup>3</sup>/<sub>4</sub> ips (9.5cm/s)
- ⑭ Automatic Shut-off Lever
  - shuts off power to transport when tape runs out.
- ⑮ Right Reel Turntable Shaft

- ①⑥ Right Reel Turntable
- ①⑦ Index Counter - indicates tape position, resets when button is pressed.
- ①⑧ TAPE TENSION  
Tape Tension Selector Switch - provides weaker tape tension when a 1/2 mil or thinner tape is used.
- ②① Playback Preamplifier Output Jacks (OUTPUT)
- ②② EQUALIZER TO AMP Socket - for connection to the equalizer of the record amplifier.
- ②③ REMOTE Remote Control Socket
- ②④ TO REC. AMP. Socket - for connection to the record amplifier.
- ②⑤ Fuse - Replace only with 2 ampere fuse.
- ②⑥ AC POWER IN AC Power Cord Receptacle
- ②⑦ C/S SELECT AC Power Supply Frequency Selector Switch
- ②⑧ VOLTAGE SELECT AC Power Supply Voltage Selector Switch

RA-40 RECORD AMPLIFIER

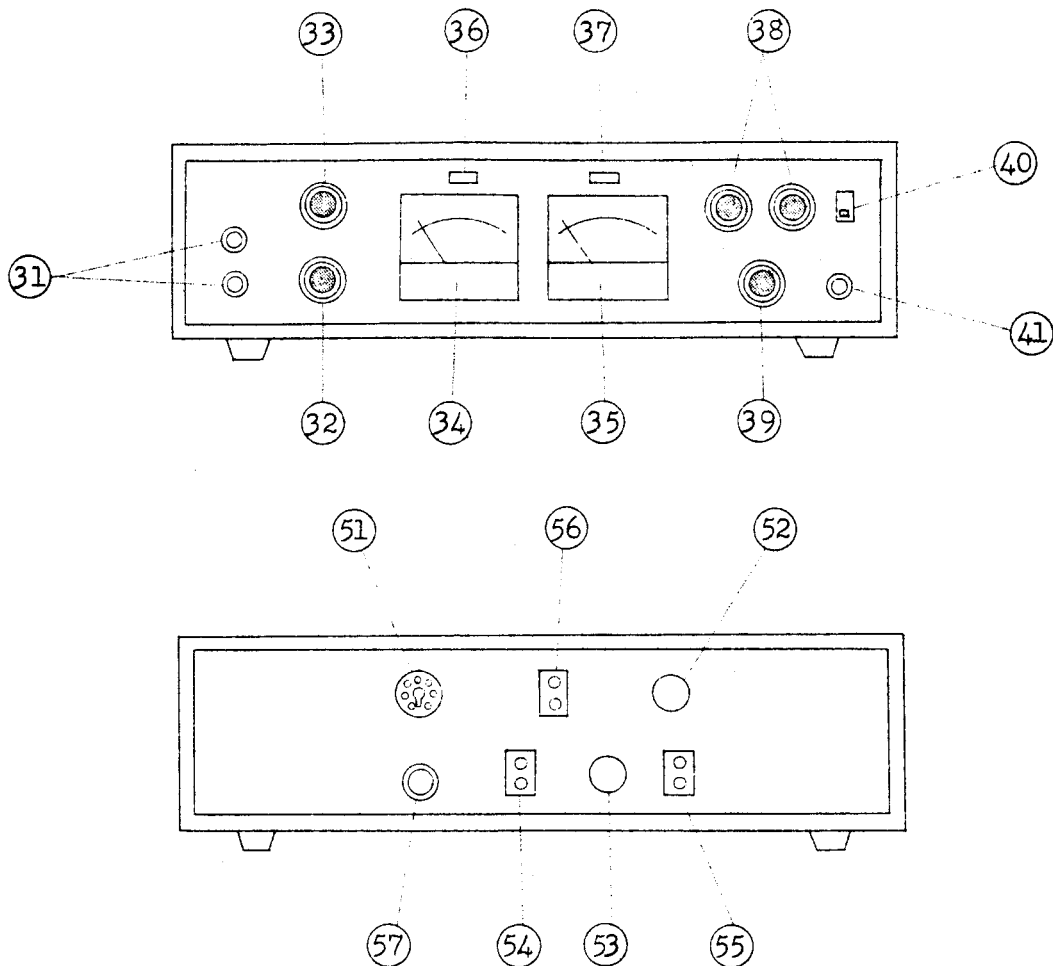

FIG. 2

- ③① **MIC IN** Mic Input Jacks
- ③② **MIC** Mic Level Control
- ③③ **LINE** Line Level Control

NOTE: Level controls shown ③② ③③ and ③⑨ above are dual potentiometers. Inner knob (Channel A) is friction coupled with outer knob (Channel B) to be operated together or separately.

- ③④ Level Indicator Meter for Channel A
- ③⑤ Level Indicator Meter for Channel B



- ③⑥ Record Pilot Lamp for Channel A
- ③⑦ Record Pilot Lamp for Channel B
- ③⑧ **RECORD SELECT** Record Selector Buttons
- ③⑨ **PLAYBACK** Playback Level Control
- ④① **MONITOR** Monitor Selector Switch
- SOURCE** position: The input signal to be recorded can be reproduced through headphones or speaker system while the VU meter indicates the level.
- TAPE** position: During playback or while recording, recorded signal on the tape can be reproduced as above.
- ④① Head Phone Jack
- ⑤① **TO DECK OUTPUT**  
Playback Input Jack - for connection to the preamplifier output of the A-4000 deck.
- ⑤② **TO DECK EQUALIZER**  
Record Equalizer Socket - for connection to tape speed selector switch.
- ⑤③ **REC/PLAY** Record Input and Playback Output Jack - for DIN (Deutsche Normen) connection.
- ⑤④ **LINE** Line Input Jack
- ⑤⑤ **OUTPUT** Output Jack
- ⑤⑥ **TO DECK** Socket
- ⑤⑦ **FUSE 2 AMP.** Fuse - Replace only with 2 ampere fuse.

## DISASSEMBLY

### REMounting UNIT FROM CASE (Refer to Figs. 3 ~ 5.)

1. Remove power cord, remote or shorting plug and audio cables.
2. Remove two screws (13)
3. Lay the recorder face down on a soft mat.
4. Remove the back panel (16) from the rear of the case by removing eight screws (15) and disconnect the TO REC AMP cable and equalizer cable.
5. Remove the case (1) from the transport by removing four screws (10).
6. Turn the recorder and lay the recorder face up on a soft mat.
7. Remove the following parts and hardware (see Fig. 3).
  - Pinch roller (3)
  - Dust cap (2)
  - Reel tables (7) (left and right) by removing three (each) screws (6)
  - Head housing (5) by removing screw (4)
  - Four mounting screws (8)
  - Face plate (9)

### REMOVING AMPLIFIER FROM CASE (Refer to Fig. 4)

1. Remove the cable of TO TRANSPORT and EQUALIZER connectors.
2. Remove four screws (5) (4).

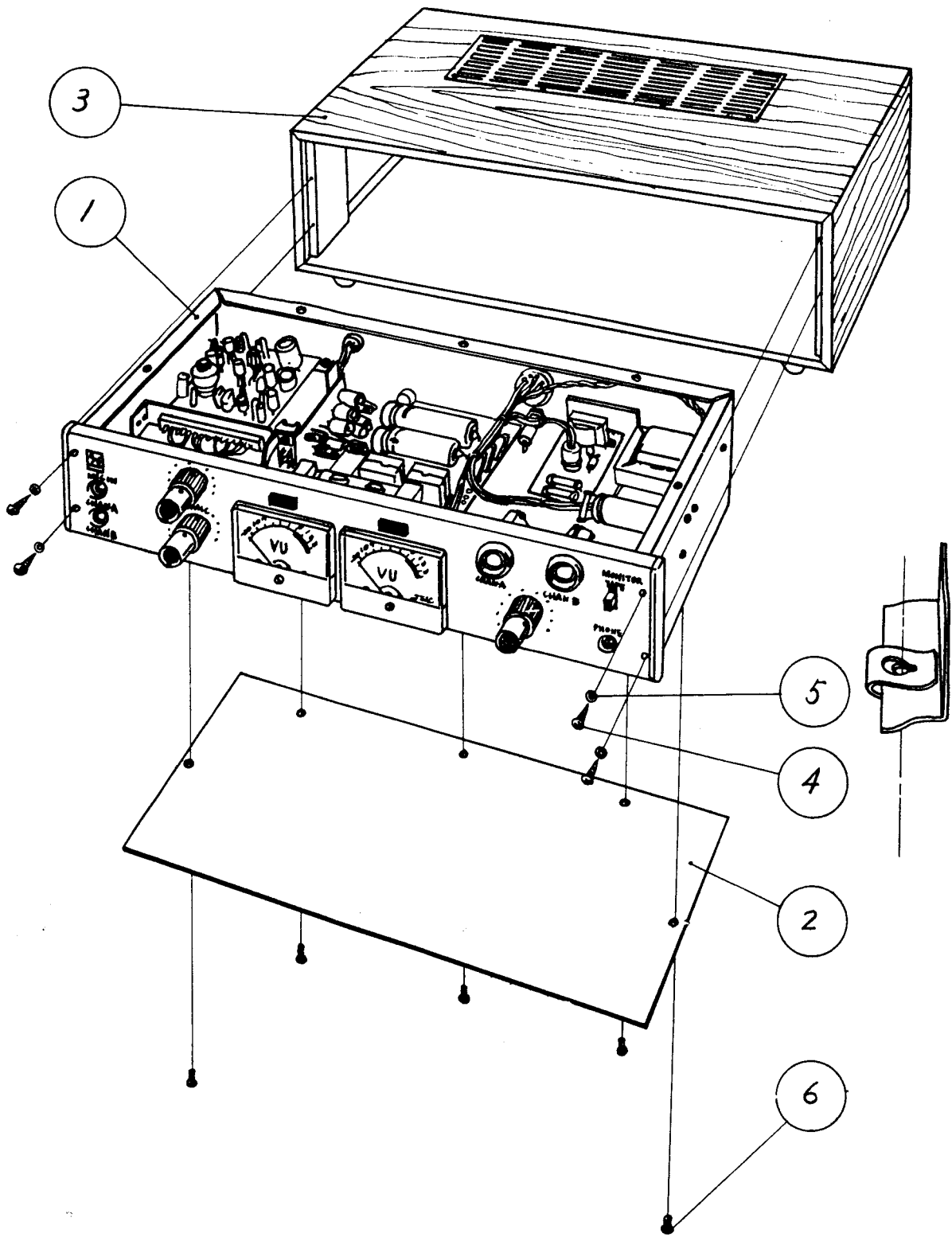

RA-40 RECORD AMPLIFIER

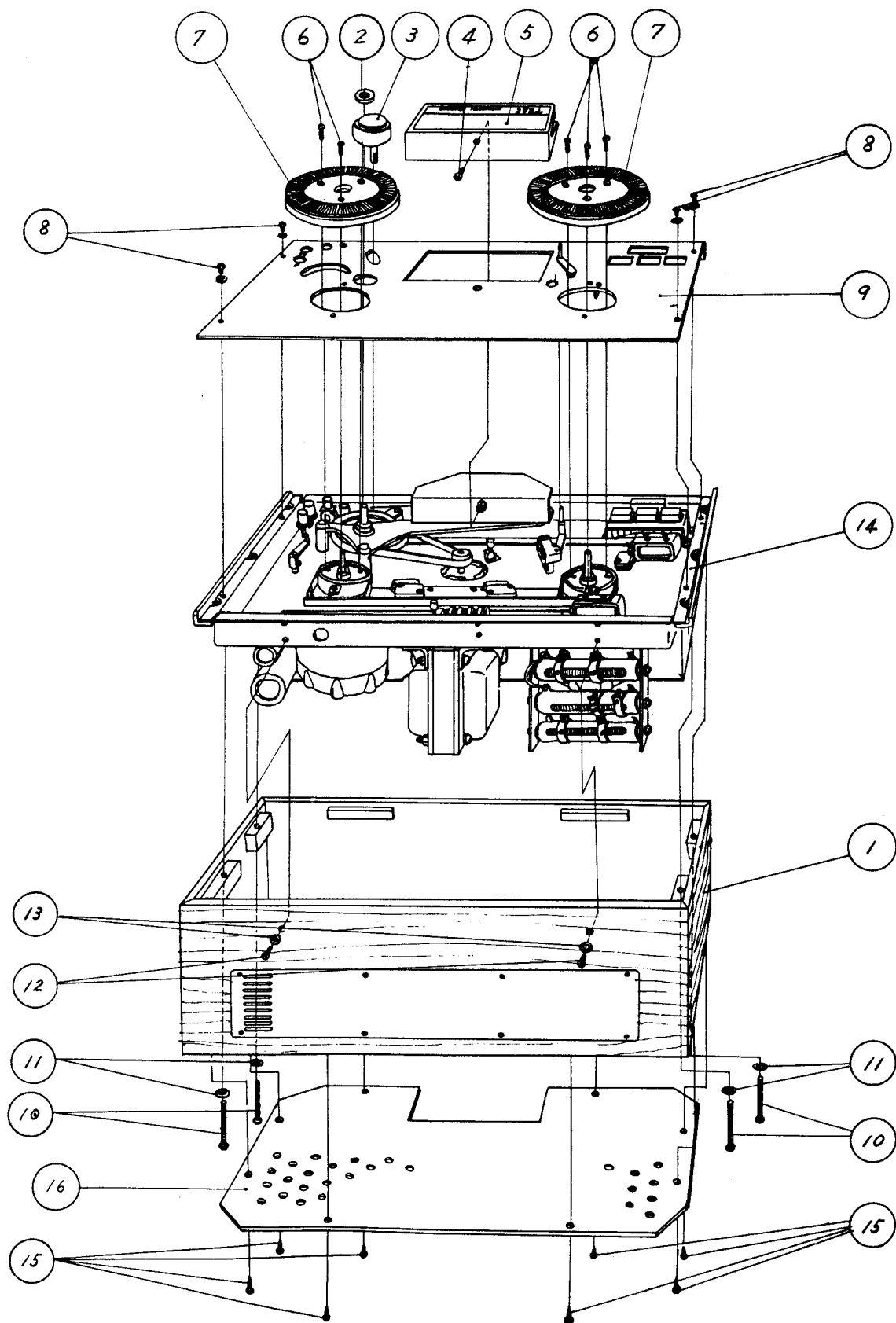

A-4000 TAPE PLAYER

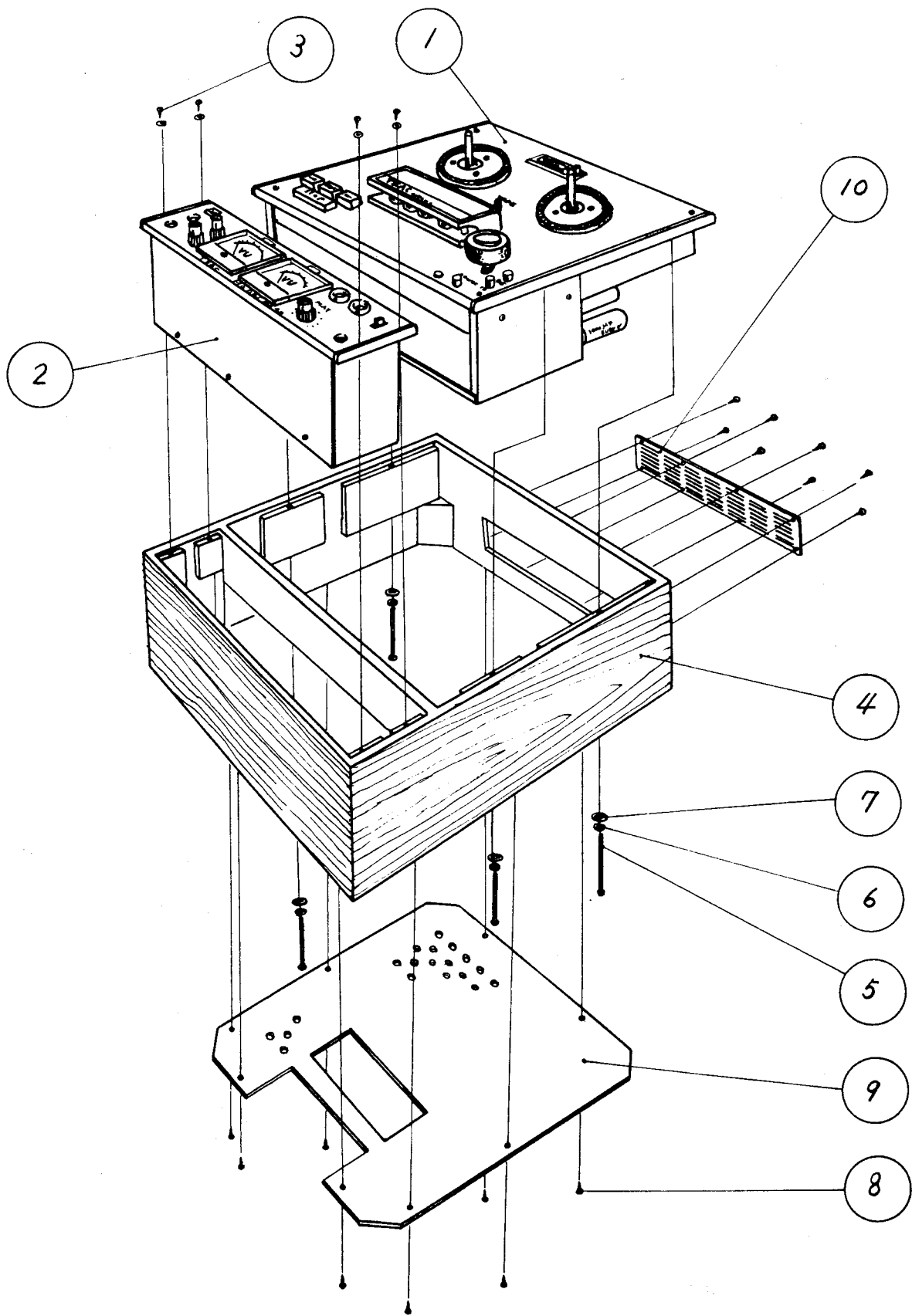

A-4010 TAPE RECORDER

## CONTROL BUTTONS

Tape transport selector switches consist of 4 push-buttons, 7 micro-switches and a solenoid for the fast button (Fig. 21). The push-buttons operate the transport for the following functions: (See Figs. 15 thru 17)

### 1. FORWARD PLAY (button marked )

When the forward play button is depressed:

- a. The brake solenoid is energized, freeing the turntables. This solenoid latches itself and remains energized after the button is released.
- b. Reduced voltages are supplied to the left and right reel motors through resistors R304 and R303 respectively.
- c. The pinch roller solenoid is energized, pulling the pinch roller against the capstan.

### 2. REVERSE PLAY (marked )

When the reverse play button is depressed:

- a. The brake solenoid is energized, freeing the turntables.
- b. Relays RL-2, RL-3 and RL-4 are energized.
- c. RL-3 reverses drive motor rotation by switching the polarity of one main field winding.
- d. RL-2 reverses reduced voltage supply to left and right reel motors by selecting preset taps on R-304 and R-303 respectively.

### 3. STOP

Depressing the STOP push-button releases all relays and solenoids. Voltage is removed from the capstan and reel motors. Brakes are engaged through spring tension.

### 4. FAST FORWARD

When the FORWARD and FAST buttons are depressed either simultaneously or FORWARD and FAST in that order:

- a. The brake solenoid is energized, freeing the reel turntables.
- b. Full AC line voltage (117 volts) is supplied to the right reel motor.
- c. The pinch roller solenoid is not energized.

5. REWIND

When the REVERSE and FAST buttons are depressed either simultaneously or REVERSE and FAST in that order similar functions are performed as described in FAST FORWARD operation. However, relay RL-2 is energized, reversing supply voltages to the reel motors.

6. RECORD (RA-40 Record Amplifier only)

When the REC buttons of CHAN-A and/or CHAN-B are depressed, record relays RL-5 and/or RL-6 are energized. These relays apply voltages to the following points:

- a. B- to the bias oscillator
- b. Bias and audio signals to the record heads
- c. Erase current to the erase heads

7. AUTOMATIC REVERSE PLAY

Permits automatic reversing of tape travel by placing sensing foil at end of tape. When the sensing pole is shorted by sensing foil, sensing relay RL-1 is energized and all functions as described in REVERSE PLAY occur.

## MECHANISM ADJUSTMENTS

### PINCH ROLLER PRESSURE ADJUSTMENT

The pinch roller is forced against the capstan by the action of pinch roller solenoid (58, Fig. 6). Pinch roller pressure is supplied by the pinch roller pressure spring, and is adjusted by a lock nut on the capstan solenoid spade bolt (31, Fig. 6). The recommended procedure for adjusting pinch roller pressure is as follows.

1. Hold the shut-off lever so that the shut-off lever switch is held in the operate position (A rubber band is convenient for this purpose).
2. With the POWER switch in the ON position, press the PLAY button, and note whether the capstan solenoid plunger is bottomed. The pressure against the capstan shaft should be approximately 4.4 pounds.
3. If it is desired to measure pinch roller pressure, press the STOP button, and using a string about 20 inches long, tied in a loop slip the loop between the pinch roller and roller arm so that the string rests against the pinch roller shaft.
4. Attach the other side of the loop to a 0 to 8 pounds scale, letting the string remain slack.
5. Press the PLAY push-button, causing the pinch roller to clamp against the capstan.
6. Pull the scale away so that the string is taut and makes a 90 degree angle with the pinch roller arm.
7. Slowly pull the scale away with sufficient strength to cause the pinch roller to pull away from the capstan, reading the scale at the instant the pinch roller leaves the capstan. The scale reading should be 4 ~ 5 pounds. If necessary, adjust the nut (28, Fig. 6).

NOTE: Reduced pinch roller pressure can result from either two extremes of adjustment. Remember that maximum efficiency is obtained from the solenoid only when its plunger is "exactly bottomed".



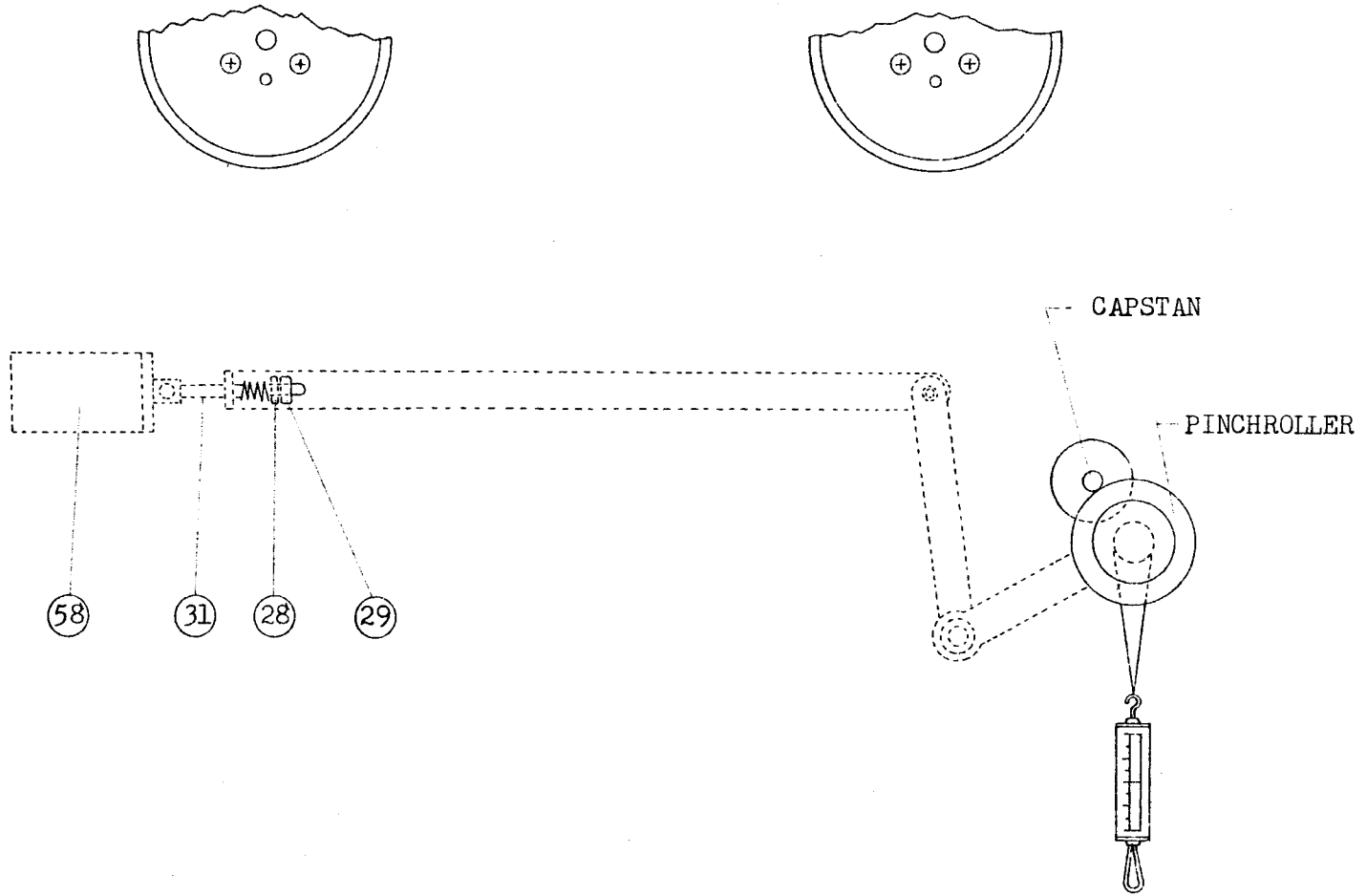
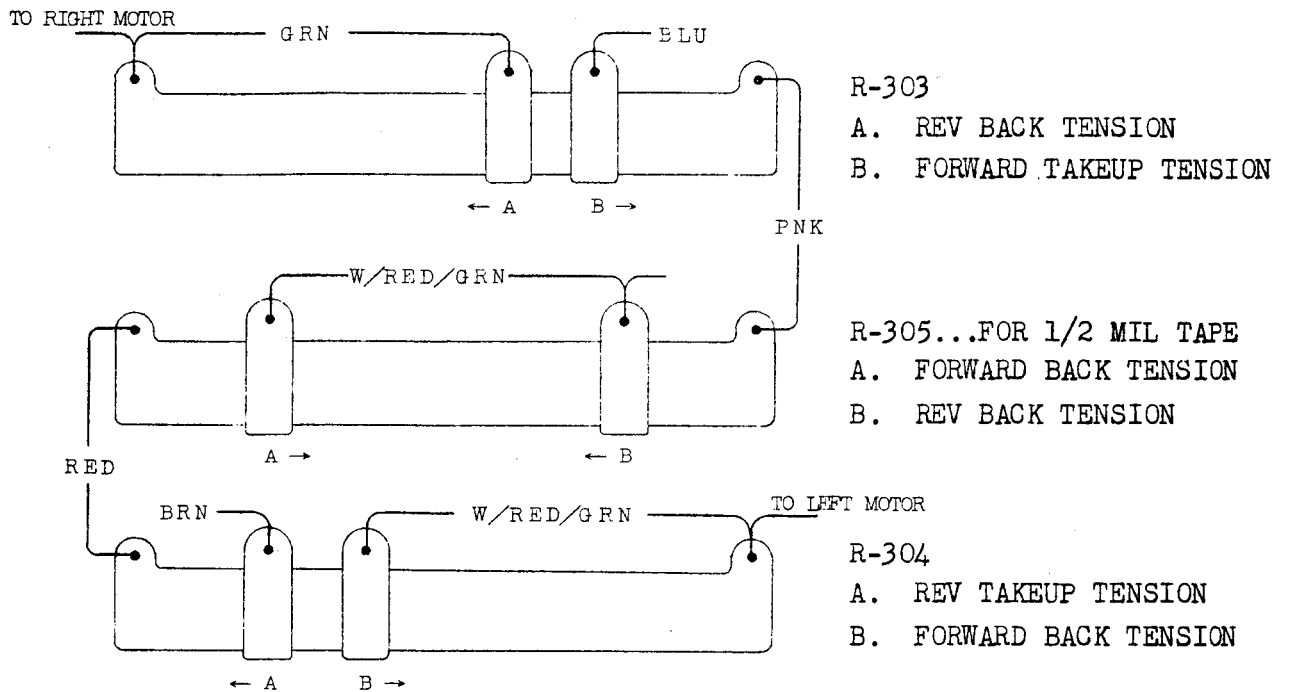

FIG. 6 PINCHROLLER PRESSURE ADJUSTMENT



NOTE: • ← A or B → DECREASE TENSION DIRECTION  
 • REV: REVERSE

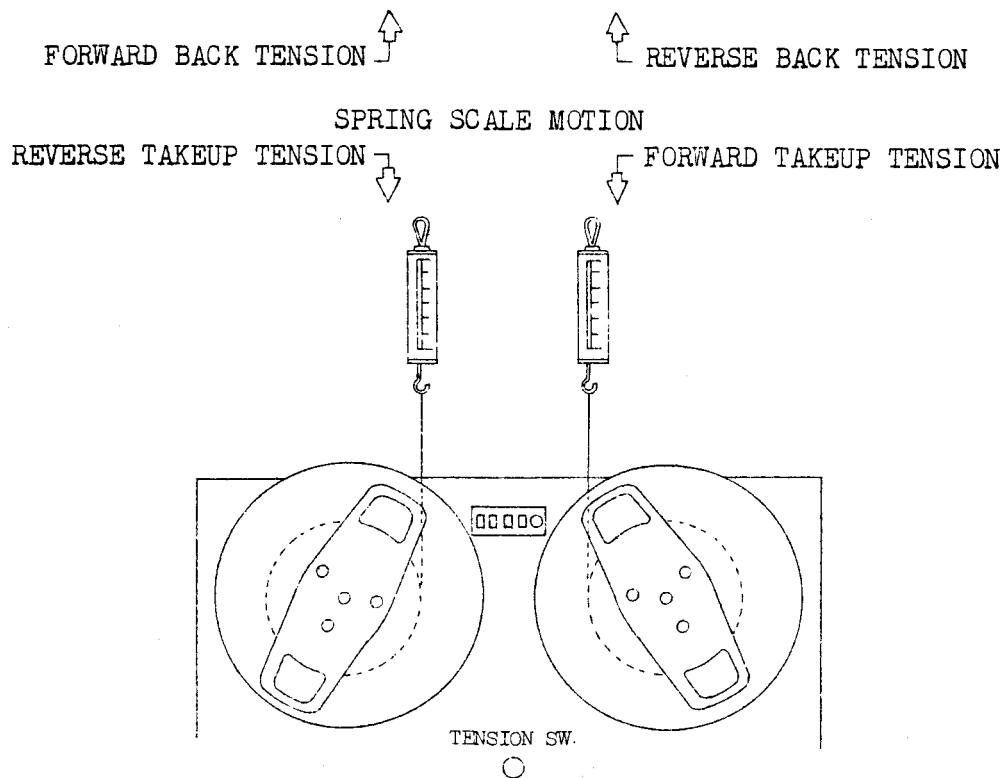



FIG. 7 TAKEUP AND SUPPLY TENSION ADJUSTMENTS

## TAKE-UP AND SUPPLY TENSION ADJUSTMENTS

Take-up and supply tensions in forward and reverse play mode are determined by the positioning of the sliders on resistors R-303, R-304 and R-305, located on the tape transport control chassis (Fig. 7). The torque of both the left and right reel motors must be adjusted as follows:-

	<u>left motor</u>	<u>right motor</u>
forward play	3.5 ± 0.7 in-oz	4.1 ± 0.7 in-oz
reverse play	4.1 ± 0.7 in-oz	3.5 ± 0.7 in-oz

1. Place an empty 7 inch reel having 4 inch diameter hub on the tape supply turntable.
2. Turn on the power switch and set the tape tension selector switch to normal.
3. Block the shut-off lever switch in the operate position.
4. Make small loops at both ends of a 30 inch piece of string.
5. Attach one loop to the tape anchor on the reel hub and the other to a 0 to 4 oz. spring scale.
6. Operate the PLAY button and allow the clockwise motion of the left reel to draw a turn of string onto the hub.
7. Make certain that the string is now parallel to the plane of the top of the tape transport and that the string is centered and not touching either reel flange.
8. Let the reel motor pull the string slowly onto the hub by following the torque motor force with the scale while observing the readings on the scale until a constant reading is obtained.
9. If necessary, adjust the slide B on resistor R-304 on the control chassis until a scale reading between 1.4 and 2.1 ounces is achieved.
10. Next operate the reverse play (  ), and check the torque using the same procedure as above. However, spring scale motions are reversed (see Fig. 7), the scale should indicate approximately 1.7 ~ 2.4 ounces by adjusting the slide A on resistor R-304.

11. Use the procedures in the preceding steps to check and adjust the right reel motor tensions which are set by the slide A on R-205 (approx. 1.7 ~ 2.4 oz.) for forward play, and slide B on R-205 (approx. 1.4 ~ 2.1 oz.) for reverse play.
12. Set the tape tension selector switch to the 1/2 mil position. Then check the torque using the same procedure as above. The scale should indicate a decrease of approximately 0.3 ounce less than the normal tension readings.

#### BRAKE ADJUSTMENT

Brake adjustment is made with no power applied to the equipment (Fig. 8).

1. Place an empty 7 inch reel having 4 inch diameter hub on the left reel turntable.
2. Make small loops at both ends of a 30 inch string.
3. Attach one loop to the tape anchor on the reel hub and the other to a 0 ~ 10 oz. spring scale.
4. Wind several turns of string onto the hub, counterclockwise.
5. Pull the scale, making certain that the string does not touch either flange of the reel. The turntable will rotate counterclockwise. Take a reading only when the turntable is in steady motion, as the force required to overcome the static friction will produce a false and excessively high initial reading.
6. Adjust the left motor brake by positioning the brake adjusting spring arm (54, Fig. 8) for a scale reading of approximately 5.5 ~ 7 ounces (11 ~ 14 in-oz.).
7. To adjust the brake on the right reel turntable, repeat the entire procedure as described for the left reel turntable, with the exception that all directions of rotation are reversed.

NOTE: The difference in reading of the right and left reel turntable brakes should be kept within 2.8 inch-ounces.

SPRING SCALE MOTION

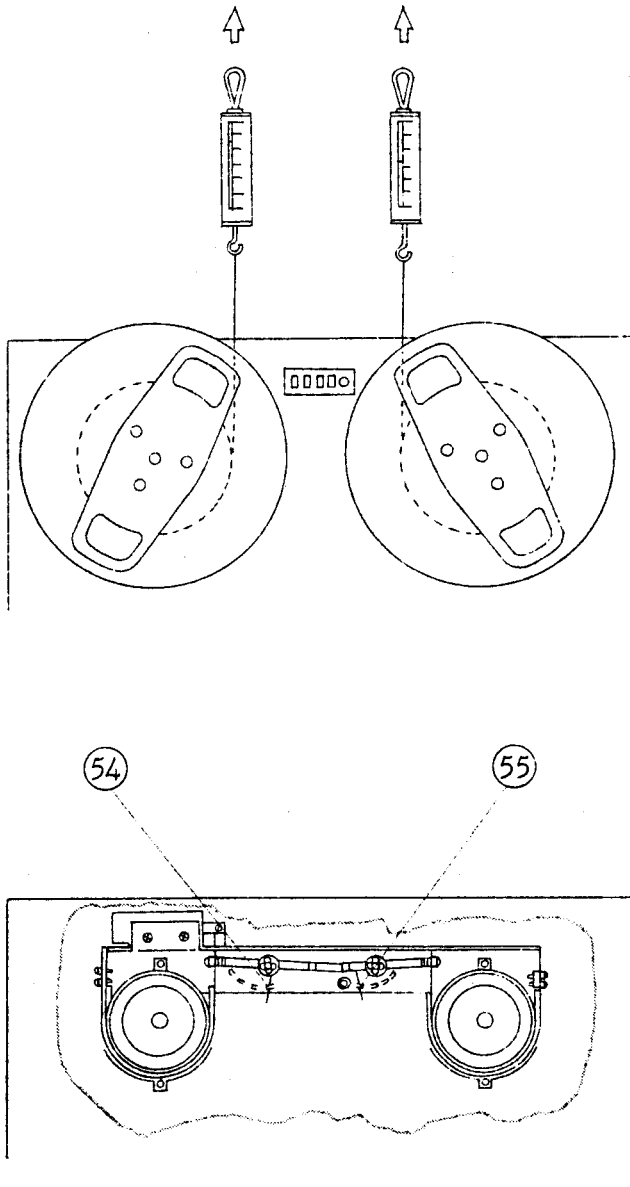

FIG. 8 BRAKE ADJUSTMENT

## ALIGNMENT AND PERFORMANCE CHECKS

### INSTRUMENTS AND TAPE REQUIRED

1. Ampex Standard Alignment Tape or equivalent  
7-1/2 ips (Ampex 31321-01) (TEAC test tape, No.62801)  
3-3/4 ips (Ampex 31331-01)
2. AC Vacuum Tube Volt Meter capable of indicating rms voltages of .003V or less
3. Standard AF Signal Generator with stable output from 50 cps to 15,000 cps.
4. Earphones of Speaker System for monitoring
5. Reel of blank tape (Scotch 150, 190 or equivalent)
6. Channel Selecting Switch

### HEAD HEIGHT ALIGNMENTS (Fig. 9)

1. Watch tape as it passes through head assembly, and observe the position of the tape at each of the heads.
2. Thread a piece of clear tape (or recording tape with oxide coating removed) across head assembly in the observed playing position. Adjust height of heads as follows:-

Erase head:	Top (front) edge of head laminations slightly (.0015") above edge of tape
Record head:	Top (front) edge of head laminations flush with edge of tape
Play (Forward) head:	Top (front) edge of head laminations slightly (.0015") below edge of tape
Play (Reverse) head:	Bottom (back) edge of head laminations slightly (.0015") below edge of tape

NOTE: Height adjustment of heads when completed should have all head surfaces, when viewed from side, aligned parallel with the tape guide surface.

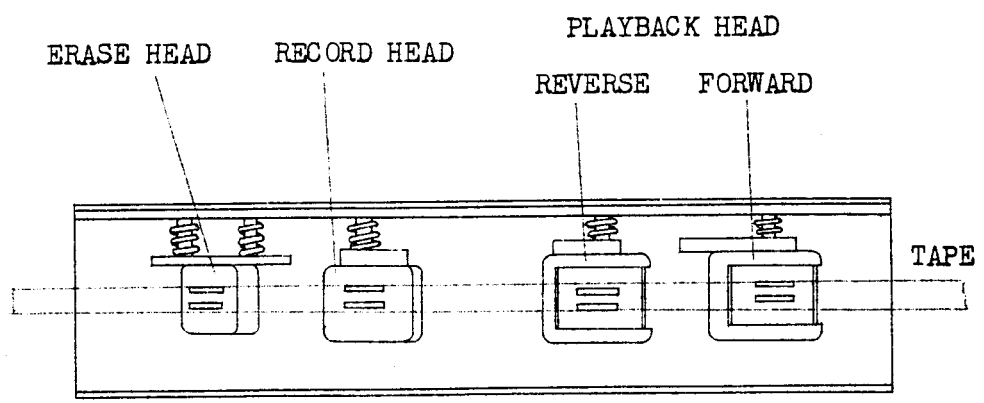
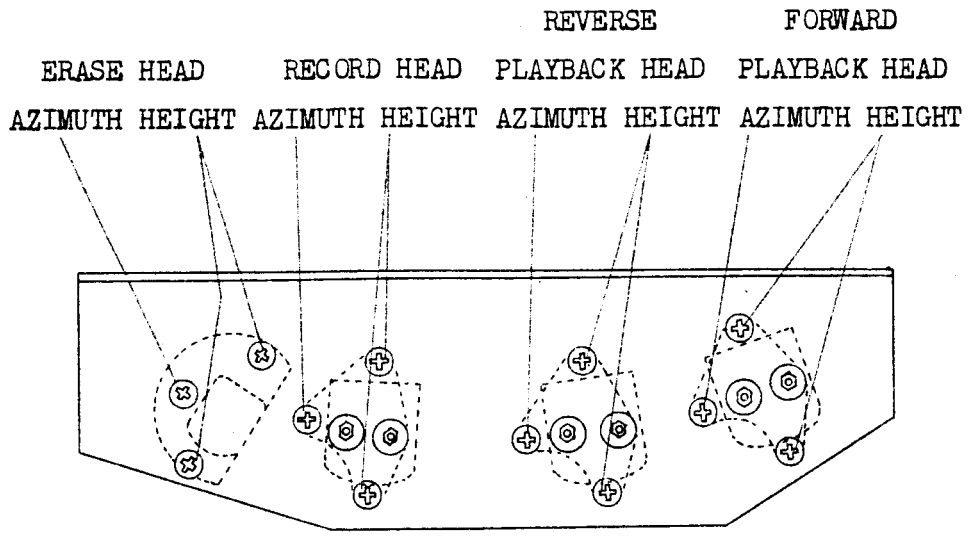

FIG. 9 HEAD ALIGNMENTS

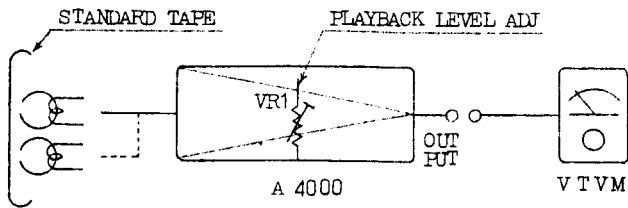

FIG. 10-A

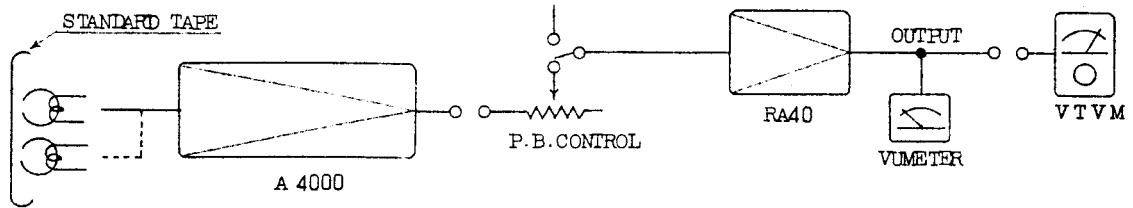

FIG. 10-B

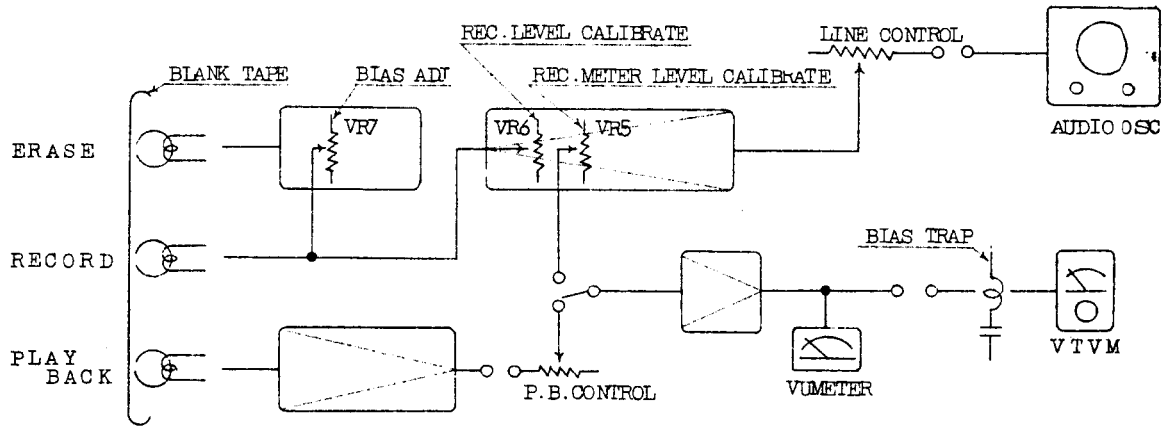

FIG. 10-C

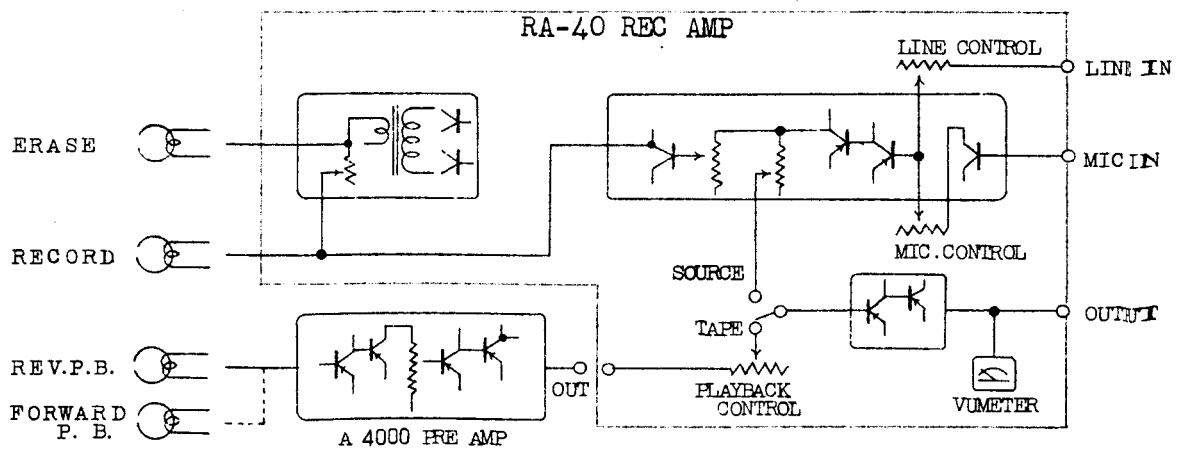

FIG. 10 CIRCUIT FOR MEASUREMENT AND BLOCK DIAGRAM



## PLAYBACK PERFORMANCE (Refer to Fig. 10-A or Fig. 10-B)

1. Thread recorder with a standard alignment tape.

CAUTION: The standard alignment tape used in the following procedures may be partially erased if the record and playback heads are permanently magnetized.

Demagnetize and clean the heads before proceeding.

2. Set the MONITOR selector switch to TAPE, and TAPE SPEED selector switch to HIGH (7-1/2).
3. Connect a temporary channel selecting switch, across the output jacks of Channels A and B, and the output of the switch to an AC VTVM.
4. Play 700 cycle (or 500 cycle) reference tone (10 db below normal operating level), adjust OUTPUT level control so that VTVM reads exactly -5 db (0.44V).

### Playback Head Azimuth

5. Play 15 kc tone and turn azimuth adjustment screw (Fig. 9) of forward playback head until maximum meter reading is obtained.
6. Reverse the direction of the tape.
7. Turn azimuth adjustment screw (Fig. 9) of reverse playback head until maximum meter reading is obtained.

### Frequency Response

8. Play (forward) the alignment tape from 15 kc to 50 cycles.
9. Check the frequency response of both channels.
10. Operate tape reverse switch, and make the same adjustments as above, for both reverse channels.
11. Check the low speed frequency response for both channels in both directions, using 3-3/4 ips alignment tape.

### Playback Level Setting (Refer to Fig. 10)

12. Disconnect A-4000 output cables from (output) jack, and change the connection of VTVM from the RA-40 output jack to A-4000 output jack (Fig. 10-A).
13. Play (7-1/2 ips, forward) 700 cycle tone recorded at normal operating level by using a standard alignment tape.
14. Adjust the playback level control on the printed circuit board (VR-1 for Channel A, VR-2 for Channel B) to obtain +4 BD reading on the VTVM.
15. Stop the tape and change the VTVM from the A-4000 output jack to RA-40 output jack. Connect A-4000 (output) jack to RA-40 (to deck output) jack (See Fig. 10-B).
16. Rewind the tape to normal operation level and playback. Adjust the playback level control to obtain 0 VU reading on the VU meter.

NOTE: When the VU meter indicates 0 VU and the OUTPUT level controls at maximum position, the output level is approx. +4 db (1.2V).

### Playback Noise Check

1. Play 700 cycle tone (normal operating level), and adjust OUTPUT level controls so that VTVM reads exactly 0 db (0.775V).
2. Stop the tape and read noise level on the VTVM.

NOTE: The signal to noise ratio measured from 3% distortion level (peak recording level) is generally obtained by adding 6 db to the value measured above.

### Playback Amplifier Check

For playback amplifier check, connect a signal generator to playback input circuit as shown in Fig. 12. Check the frequency response, noise, amplifier gain, etc.

NOTE: 1. Excessive input may cause overloading and distortion in

the amplifier. Adjust the output level of the signal generator so that the VU meter indication is kept below 0 VU.

2. This is a high gain circuit. Make certain that the signal generator and input cabling are free from hum generation and pick-up, which may cause false readings.

Fig. 12 shows a typical frequency response curve and Fig. 13 shows a typical voltage chart.

## RECORDING PERFORMANCE

### Record Bias Adjustment

1. Connect a signal generator to Channel A LINE input. Set MONITOR selector switch to TAPE position, RECORD SELECTOR switch in STEREO position, TAPE SPEED selector switch to HIGH (7-1/2).
2. While recording a 500 cycle tone on tape, adjust Channel A bias potentiometer (VR7, Figs. 37 and 38) for maximum output. Then turn the bias potentiometer counterclockwise until output meter reading decreases by 0.5 db from the maximum level.
3. Connect the signal generator to Channel B LINE input, and perform the same steps as above adjusting Channels B bias adjustment potentiometer (VR8, Figs. 38 ~ 9).

### Record Level Calibration (See Fig. 10-C)

NOTE: The playback level must be calibrated using a standard tape prior to calibrating the record level (See Playback Level Setting STEP 16).

1. Connect a temporary channel selecting switch, across the output jack of Channels A and B, and the output of the switch to an AC VTVM. Set MONITOR selector switch in TAPE position, and TAPE SPEED selector switch to HIGH position.

2. Turn LINE INPUT level control of both channels to maximum.
3. Set the signal generator output level at -16 db (0.12 volt), 500 cycles.
4. While recording a 500 cycle signal on the tape, adjust Record Level Calibration (VR6, Fig. 34) to obtain VU meter reading of exactly 0 VU.
5. Set MONITOR selector switch to SOURCE position.
6. Adjust Record Meter Level Calibration (VR5, Fig. 34) to obtain VU meter reading of exactly 0 VU.

#### Record Head Azimuth

1. Connect a signal generator to Channels A and B LINE INPUT. Connect a temporary channel selecting switch, across the output jacks of Channels A and B, and the output of the switch to a VTVM. Set MONITOR selector switch to TAPE position, and TAPE SPEED selector switch to HIGH (7-1/2) position.
2. While recording a 15 kc signal on the tape, set LINE INPUT level control so that meter reads -15 ~ 20 db below normal operating level (-15 ~ 20 VU on VU meter), and then adjust the record head azimuth screw (Fig. 9) for maximum output.
3. Check setting by repeating the above procedure using Channel B.

#### Overall Frequency Response

To avoid tape saturation, overall frequency response check at 7-1/2 ips and 3-3/4 ips should be made at least 20 db below operating level.

1. Connect a signal generator to Channel A LINE input. Set MONITOR selector switch to TAPE position, TAPE SPEED selector switch to HIGH (7-1/2).
2. While recording a 500 cycle signal on the tape set LINE INPUT level controls to obtain VU meter reading of 0 VU, and adjust OUTPUT level controls to obtain a VTVM reading of exactly 0 db (0.775 V).

3. Reset LINE INPUT level control to obtain a VTVM reading of exactly -20 db (77.5 mV).

NOTE: If bias frequency signal leakage is indicated on the VTVM, a filter as shown in Fig. 12 can be used at the input of the VTVM.

4. Record signals from 50 cps to 15 kc at 7-1/2 ips, or from 50 cps to 7.5 kc at 3-3/4 ips on tape, and read the output on VTVM. Check the frequency response of both channels.

If adjustment is required, replace C65 for 7-1/2 ips and C64 for 3-3/4 ips.

#### Record Noise Check

1. While recording a 500 cycle signal on the tape, adjust LINE INPUT level control to obtain a VTVM reading 6 db above normal operating level.
2. Set the LINE and MIC INPUT level controls to minimum.
3. Rewind the tape to the beginning portion of the 500 cycle recording.
4. Record the tape with LINE and MIC INPUT level controls at minimum position, over the portion where plus 6 VU recording was made, and make certain that erasure is being accomplished.
5. Erase the tape by recording with no signal input.
6. Rewind the tape to the beginning of the recording.
7. Read the VTVM indication for noise level while playing back the portion which had been previously recorded.

#### Record Amplifier Check

If a check of the record amplifier is required, connect a signal generator to record input circuit as shown in Fig. 12, then check the frequency response, noise, amplifier gain, etc.

NOTE: To avoid overloading the amplifier, frequency response check should be made at least 20 db below normal operating level.

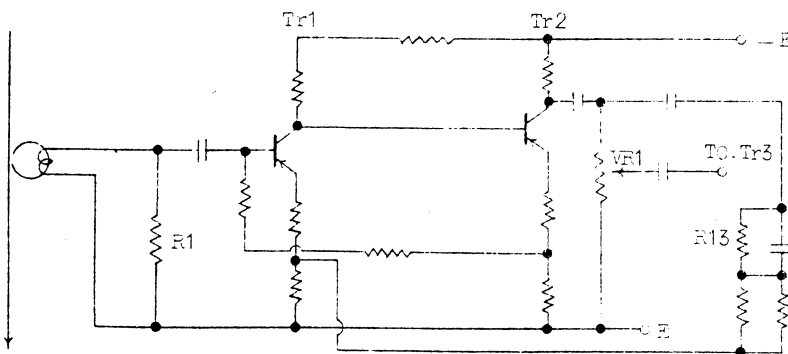

- A-4000 PLAYBACK AMPLIFIER IN BASIC TWO STAGES
- CH-A 7-1/2" TAPE SPEED MODE
- VR 1 SEMI-FIXED

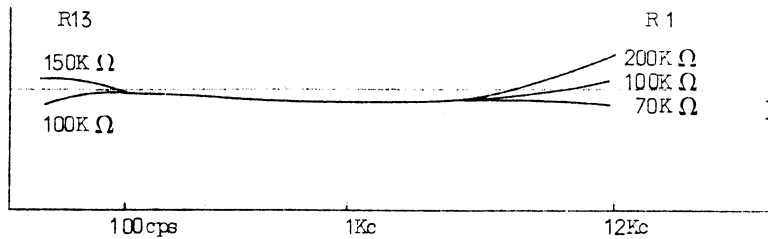

EXAMPLE

CH-A 7-1/2" PLAYBACK FREQUENCY-RESPONSE

- HIGH FREQUENCY WILL INCREASE WITH AN INCREASE IN R1 (FIG. 28).
- LOW FREQUENCY WILL INCREASE WITH AN INCREASE IN R13 (FIG. 28).

FIG. 11-A

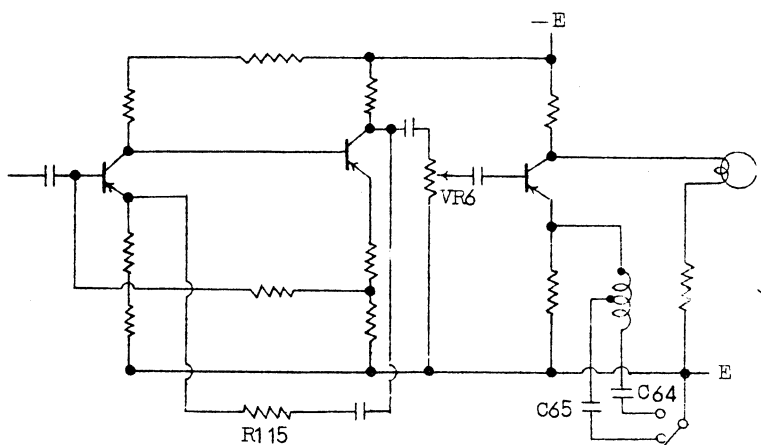

BLANK TAPE

REC HEAD

- RA-40 RECORD AMPLIFIER IN BASIC THREE STAGES
- CH-A 7-1/2" TAPE SPEED MODE
- VR 6 SEMI-FIXED

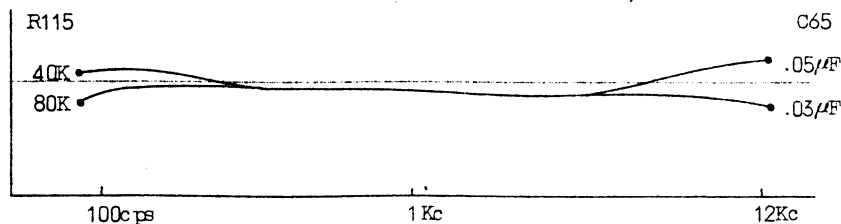

EXAMPLE

CH-A 7-1/2" OVERALL FREQUENCY-RESPONSE

- HIGH FREQUENCY WILL INCREASE WITH AN INCREASE IN C65. (FIG. 34)
- LOW FREQUENCY WILL INCREASE WITH AN INCREASE IN R115. (FIG. 34)

FIG. 11-B FREQUENCY RESPONSE ADJUSTMENT POINTS

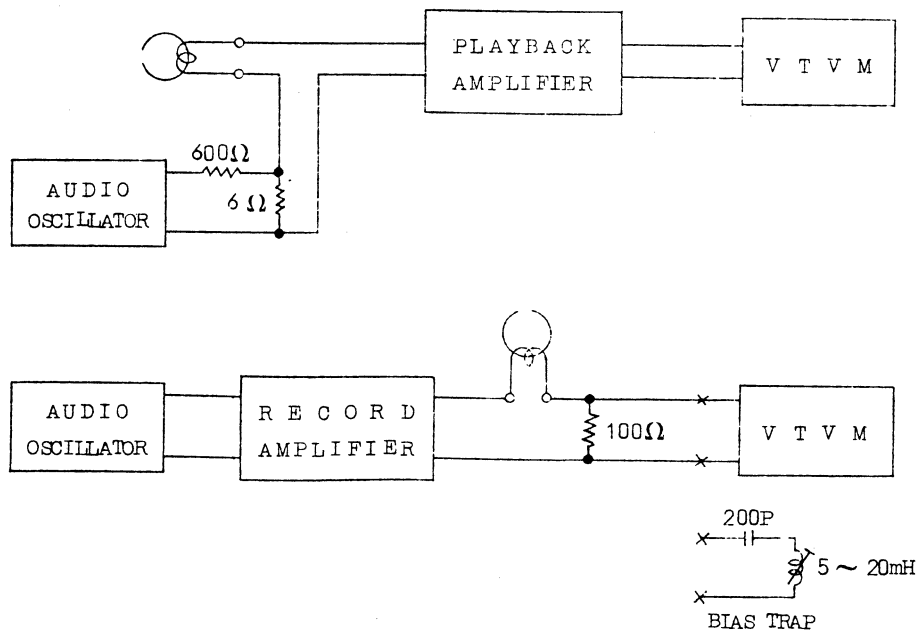
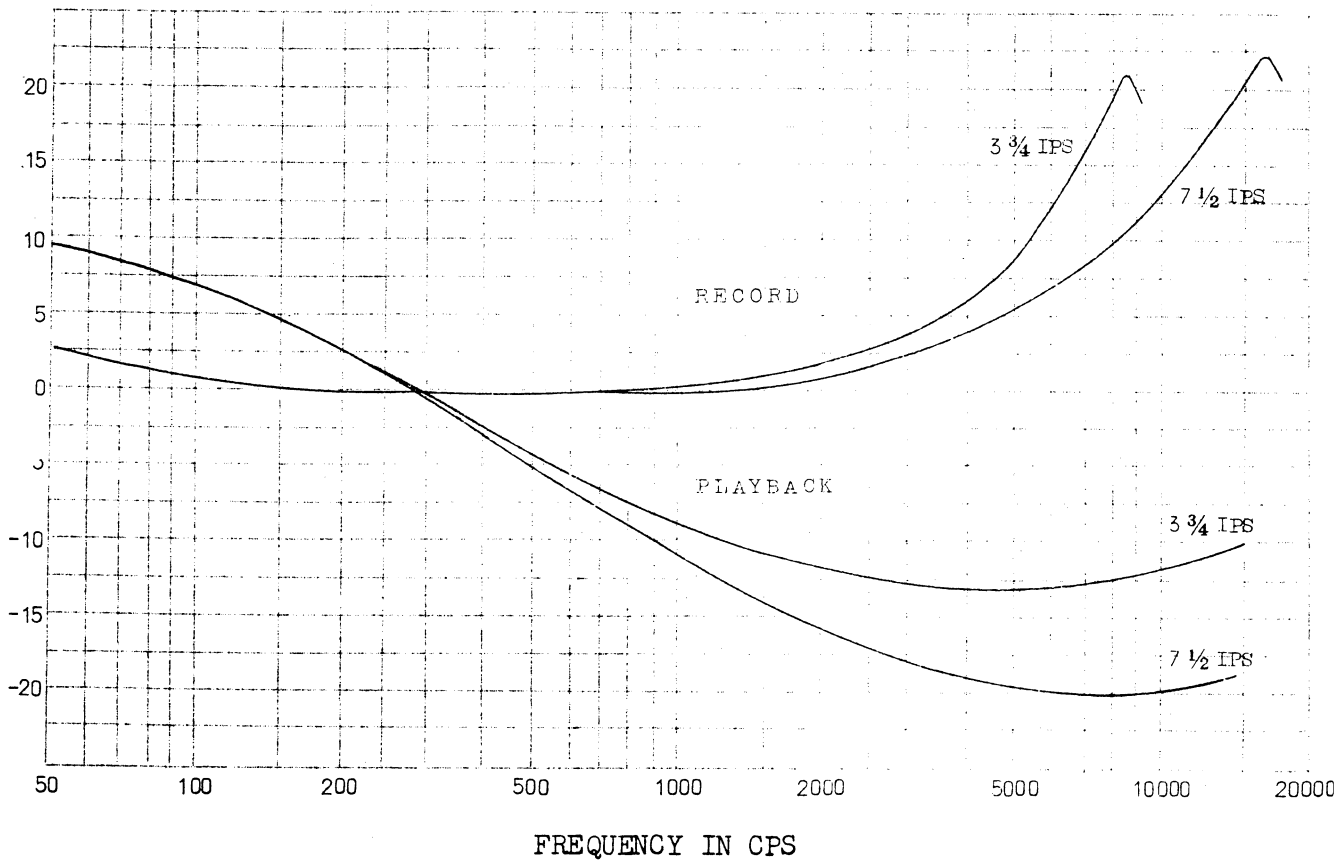
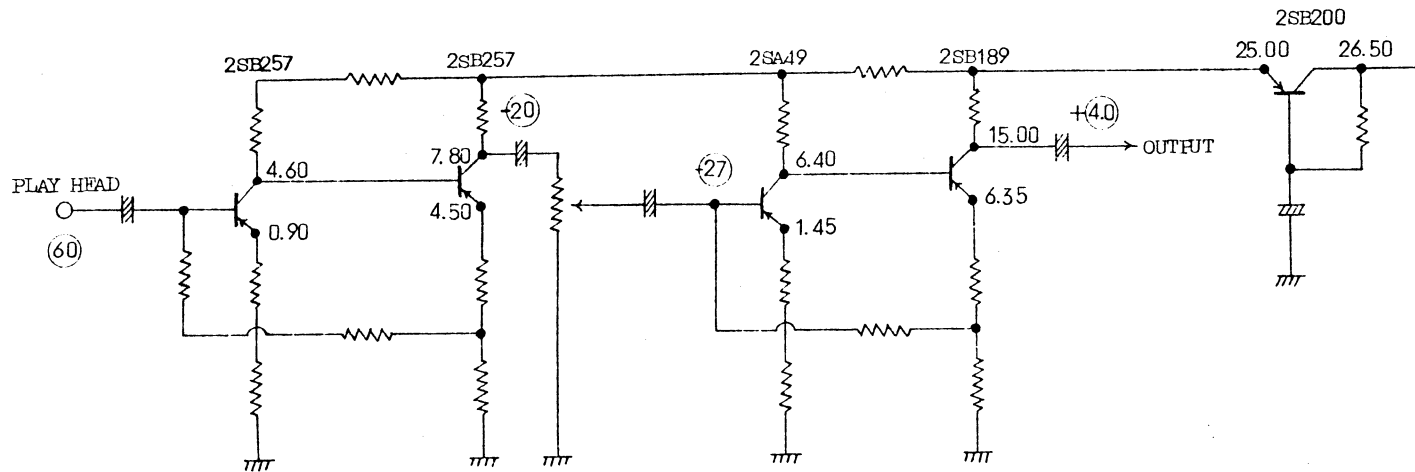

FIG. 12 AMPLIFIER MEASUREMENTS

Figure 12 shows a typical record amplifier response curve, and Figure 14 shows a typical record amplifier voltage check chart.

If a check of the recording monitor circuit (record input to line output) is required, connect a signal generator to record input circuit, and an VTVM across output jacks. Set MONITOR selector switch to SOURCE position. Check the frequency response, noise, etc.





NOTE: • NUMBER IS D.C VOLTAGE (MEASURED WITH  
20  $\kappa\Omega$  /V METER)

○ NORMAL OPERATING LEVEL IN DB  
0 DB = 0.775 V

ALL VOLTAGES MEASURED AT 117 V WITH  
MACHINE IN STOP MODE

7-1/2 TAPE SPEED

FIG. 13 A-4000 PLAYBACK AMPLIFIER LEVEL AND D.C VOLTAGE CHART

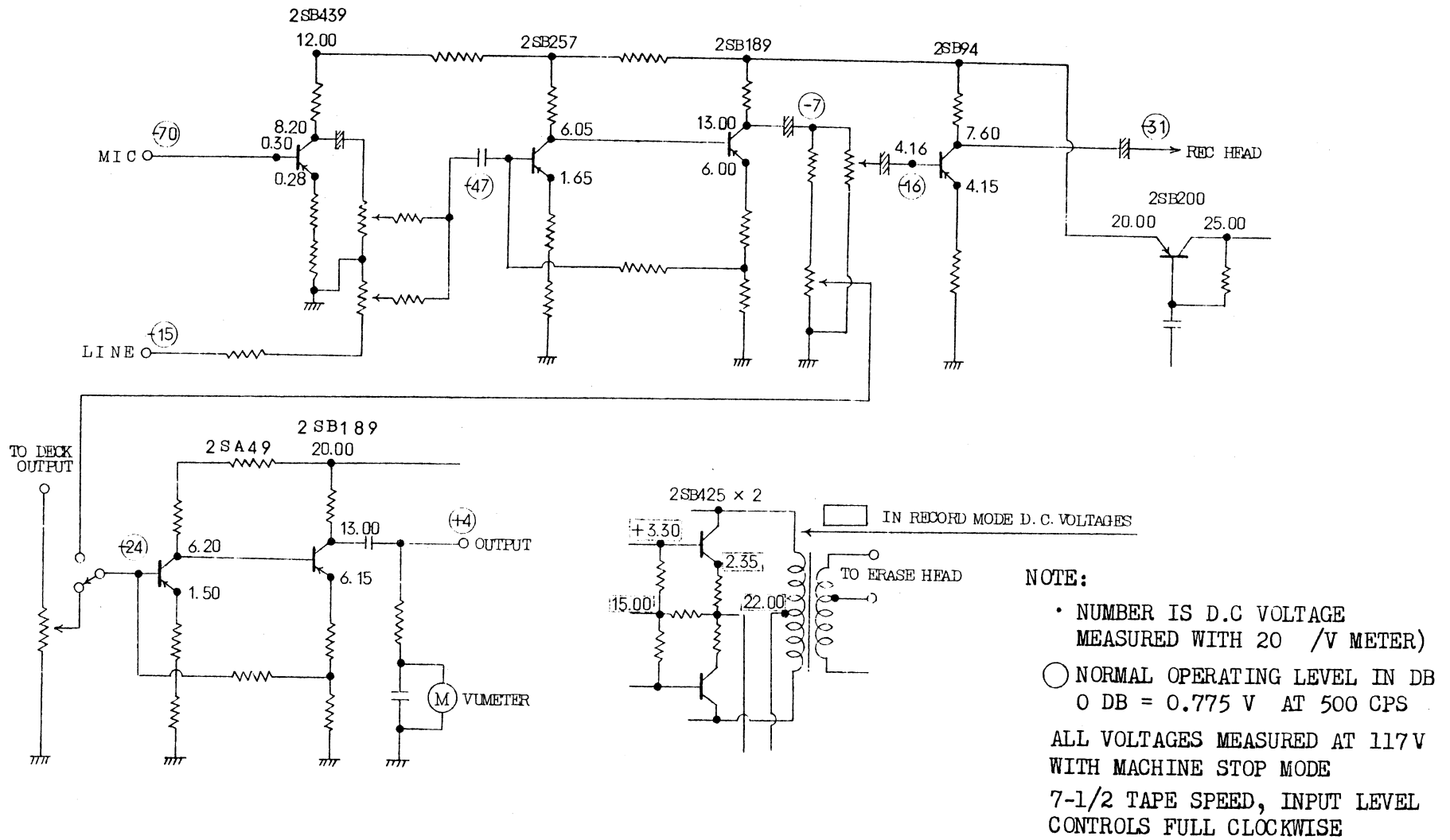

FIG. 14 RA-40 RECORD AMPLIFIER LEVEL AND D.C VOLTAGE CHART

## MAINTENANCE

### CLEANING THE HEADS

To prevent the loss of high frequency response or insufficient erasure, the heads should be cleaned frequently. Under average operating conditions, cleaning the heads after each eight to ten hours of use will insure against the loss of high frequency response. To clean the head, moisten a clean, lintless cloth with carbon tetrachloride, alcohol. Carefully wipe the face of each head and the tape guides to remove all traces of dirt and magnetic oxide deposits.

### DEMAGNETIZATION

The tape heads should be demagnetized occasionally with a head demagnetizer to maintain the best possible performance of the equipment and to prevent the possibility of gradual deterioration of your recorded tapes.

CAUTION: Do not allow the demagnetizer to come in close proximity with the level indicator meter, as permanent damage to the meter may result.

Demagnetizing:

To demagnetize the heads, use a two-pole type of demagnetizer, with a piece of ordinary splicing tape over the tips. With the power completely removed from the recorder, gently place the protected tips against the upper pole-pieces of the first head. Then slowly move the tips downward toward the lower pole-pieces of the head. Alternate between the two sets of pole-pieces while slowly withdrawing the demagnetizer. Repeat this process for each of the heads. Do not remove the power from the demagnetizer until it is at least 2 feet away from the recorder.

LUBRICATION

Most of the rotating parts of the transport have been permanently lubricated at the factory. Further lubrication should be limited to applying SAE-10, non-detergent oil to the following points if there should be evidence of binding or dragging.

Capstan assembly top bearing ....	2 drops	(after every 300 hours of use)
Pinch roller bearing .....	1 drop	( " )
Capstan motor .....	2 drops	(after every 3,000 hours of use)

Remove excess oil from pinch roller and capstan with isopropyl alcohol.

## TROUBLE SHOOTING

### Capstan fails to turn when unit is switched on.

1. Line fuse (F1) blown
2. Brake solenoid (58) or micro-switch (42) defective
3. Drive belt (8) off or broken
4. Capstan shaft or bearing defective
5. Capstan motor defective
6. Bad contacts on reverse relay (RL-2)
7. Tape speed selector switch (204) defective
8. Capacitor (206) C-206, C-204 defective
9. Shut-off switch (66) defective

NOTE: Capstan. Brake solenoid 12 ~ 13 k ohm D.C.

### Pinch roller fails to contact capstan.

1. DC fuse (F2) open
2. Jumper plug not in remote control socket
3. Capstan solenoid (58) defective

### DC fuse open.

1. Silicon diode (D205) defective
2. Capacitor, C202, C225, C226, defective
3. Solenoid coil shorted (58) (417)
4. Relay coil shorted (RL-2) (RL-3)

### Take-up reel fails to rotate when Fast Forward or Forward Play is depressed.

1. Resistor R-205 open (when Forward Play fails take-up)
2. Brake drum (82) loose on motor shaft
3. Bad contact on switch (401)
4. Right motor defective
5. Right hand brake defective
6. Capacitor C-217, C-219 defective
7. S.V. solenoid defective (when Fast Forward fails)

No reverse play

1. Sensing post (150) dirt or (F-3) open (when automatic reverse)
2. Bad contacts or defective relay (RL-1) or (RL-3)

No REWIND

1. Brake drum (82) loose on motor shaft
2. S.V. solenoid defective
3. Left motor defective
4. Brake defective
5. Capacitor (C-207, C-235) defective

WOW and FLUTTER

1. Capstan assembly defective
2. Back tension improper
3. Drive belt on oil

Tape spillage when transport is stopped.

1. Oil on brake drums (82) or brakes
2. Brake springs weak or broken

No sound in playback

1. Lifter (16, 17) defective
2. F-3 fuse blown
3. Playback head defective
4. Amplifier defective
5. Tape twisted (oxide out)

No erasing

1. Foreign matter on erase head (clean head)
2. Bias oscillator circuit defective
3. Erase head defective

No recording

1. Record head defective or dirt
2. Amplifier defective
3. Bad contacts on VR-6
4. Bias oscillator circuit defective

Weak or distorted sound

1. Foreign matter on heads
2. Heads magnetized
3. Poor bias adjustment
4. Amplifier defective
5. Power line too high (when recording distortion noise)

Cross talk in playback

1. Bad contacts on RL-4 (clean contacts)

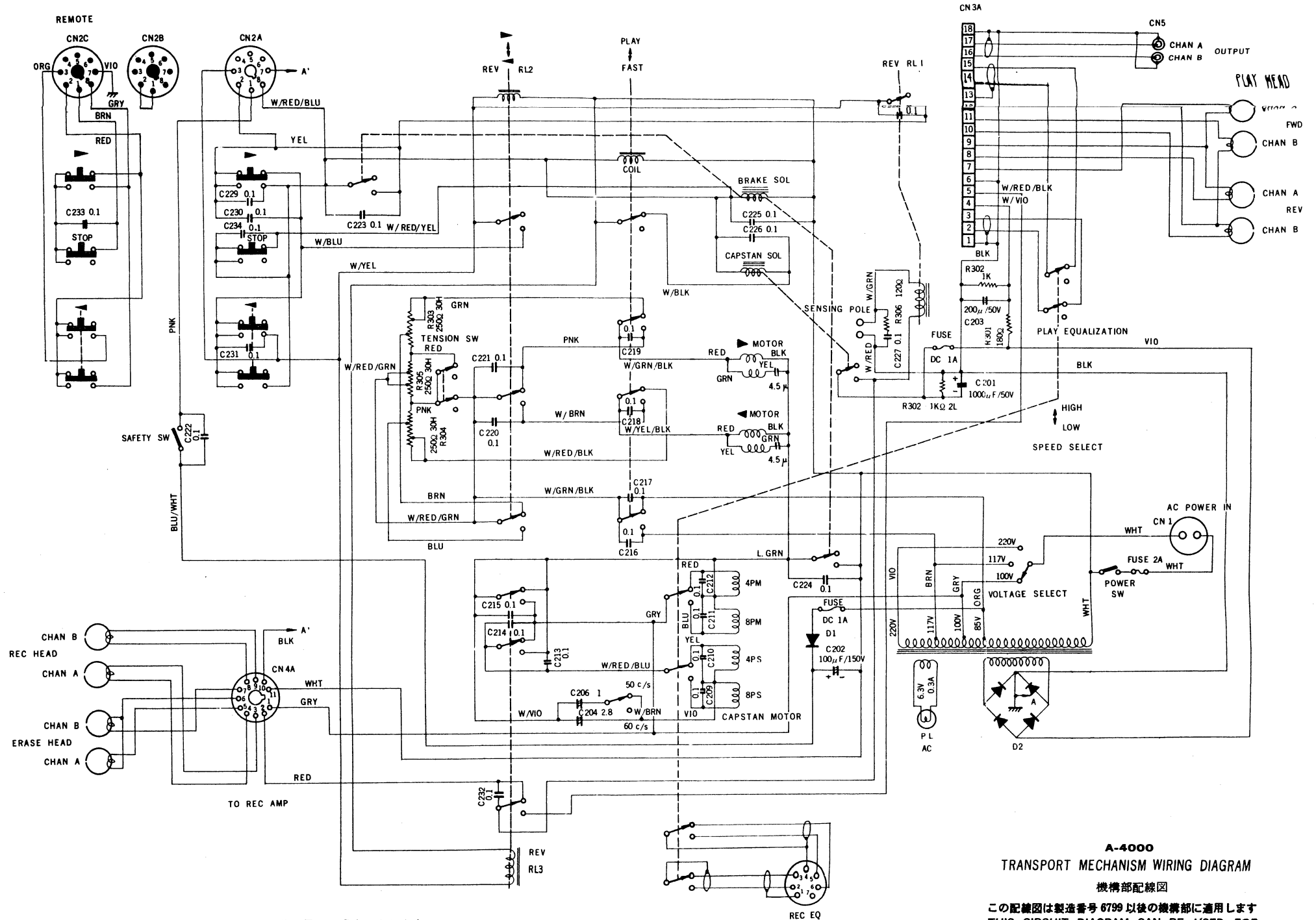



注 基本回路図につき改良などにより若干異なる場合もあります  
 COMPONENT VALUES ARE SUBJECT TO CHANGE WITHOUT NOTICE.

**A-4000**  
 TRANSPORT MECHANISM WIRING DIAGRAM  
 機構部配線図

この配線図は製造番号 6799 以後の機構部に適用します  
 THIS CIRCUIT DIAGRAM CAN BE USED FOR  
 MACHINES AFTER SERIAL NO. 6799.

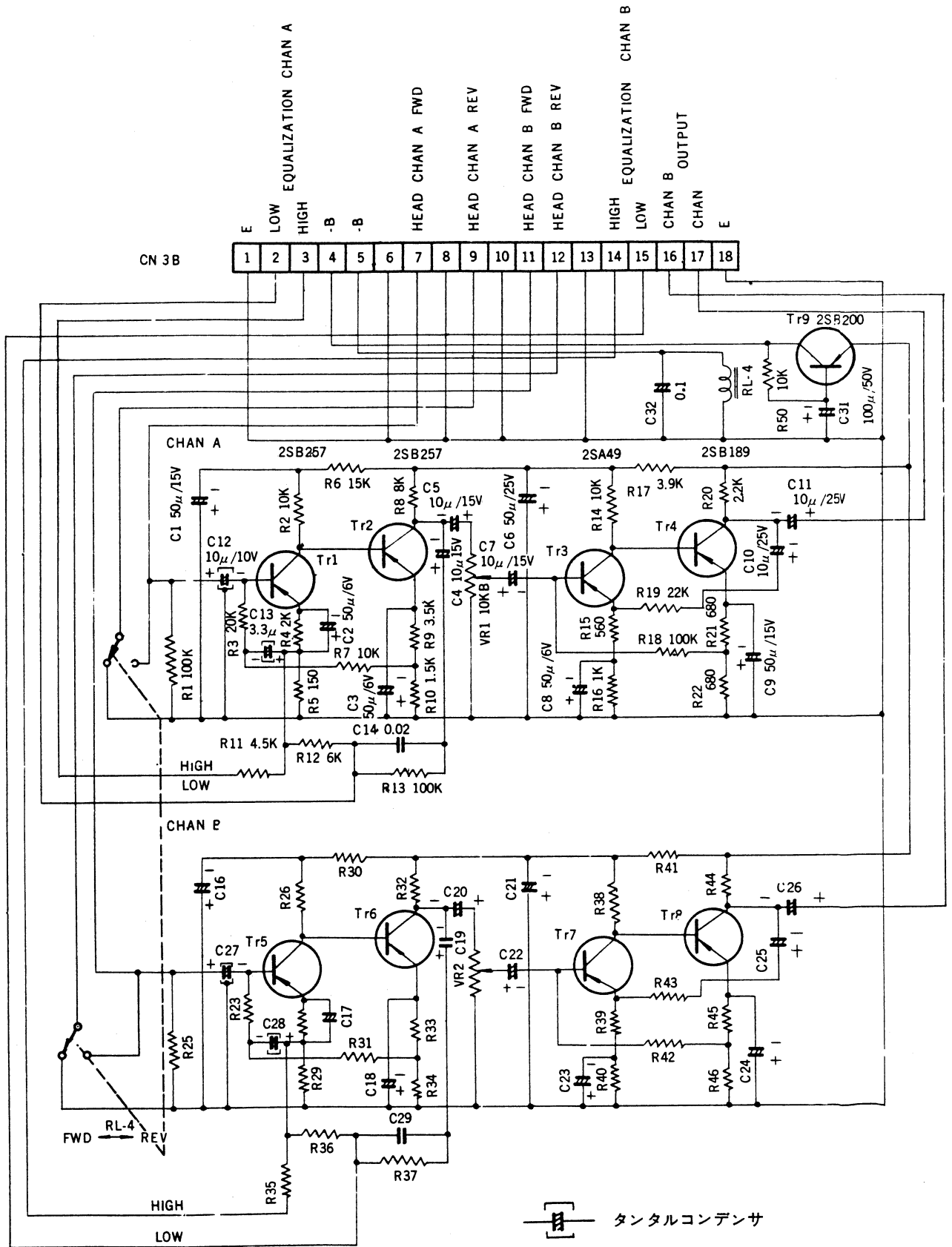



 タンタルコンデンサ

注 基本回路図につき改良などにより  
若干異なる場合もあります  
COMPONENT VALUES ARE SUBJECT  
TO CHANGE WITHOUT NOTICE.

**A-4000**  
AMPLIFIER SCHEMATIC DIAGRAM  
アンプ回路図

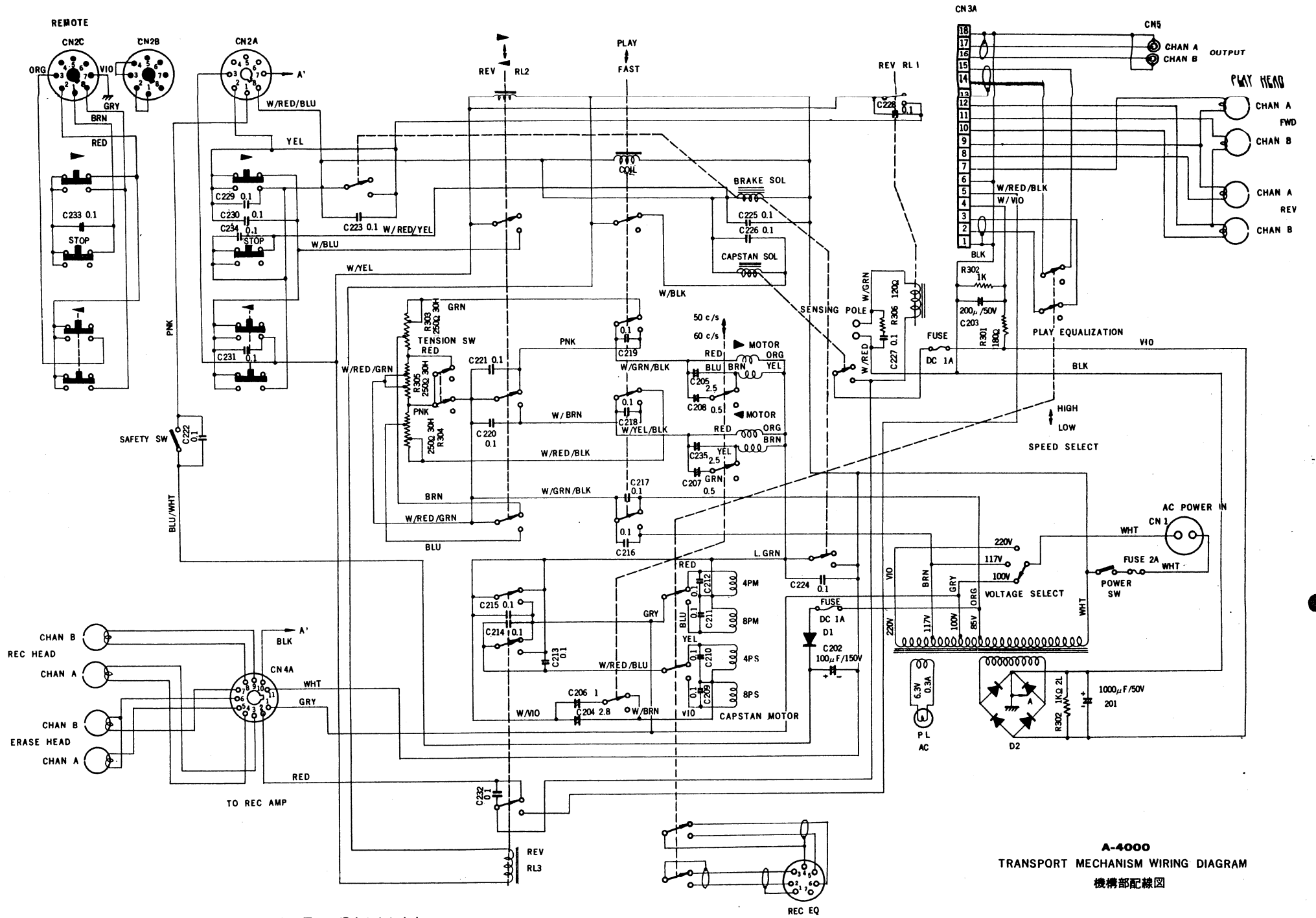

**A-4000**  
**TRANSPORT MECHANISM WIRING DIAGRAM**  
**機構部配線図**

注 基本回路図につき改良などにより若干異なる場合もあります  
 COMPONENT VALUES ARE SUBJECT TO CHANGE WITHOUT NOTICE.

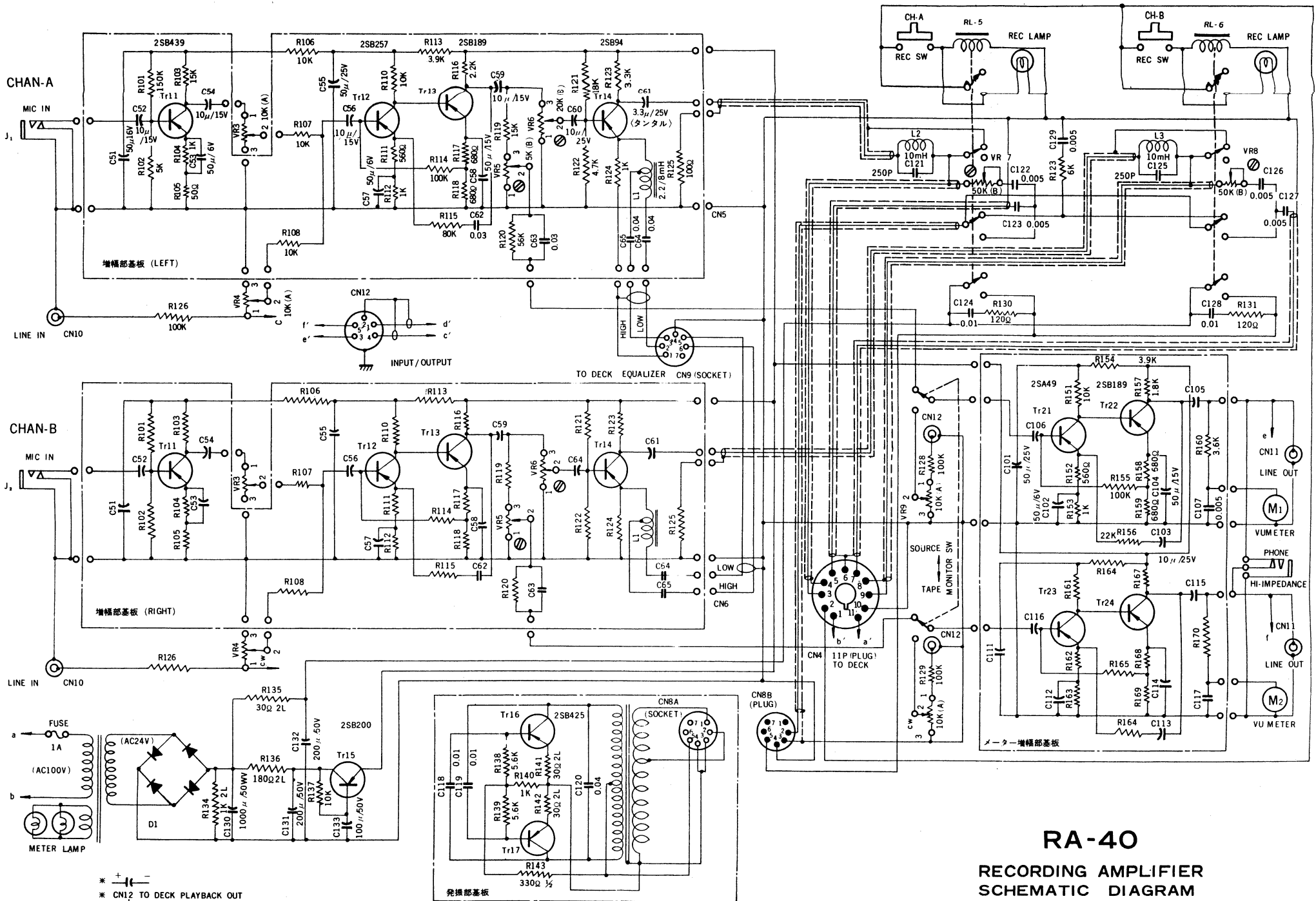

**RA-40**  
**RECORDING AMPLIFIER**  
**SCHEMATIC DIAGRAM**

増幅器回路図

\*

\* CN12 TO DECK PLAYBACK OUT  
 \* MULTI CONNECTOR  
 \* 基本回路図につき改良などによりセットによっては若干異なる場合があります。  
 COMPONENT VALUES ARE SUBJECT TO CHANGE WITHOUT NOTICE.

FIG. 1 TRANSPORT--TOP

REF. NO.	PART NO.	DESCRIPTION
60	18024	Shut-off Arm Ass'y
61	18014	Shut-off Arm
62	18170	Stop-Ring
63	22034	Arm Spring
64	18194	Arm Cover
65	18148	Stopper
66	44611	Shut-off Switch
67	18125	Magnet
68	18171	Magnet Catcher
70	18020	Tension Arm Ass'y
80	16140	Reel Holder
81	16132	Reel Table
82	17185	Brake Drum
83	17172	Brake Guard
84	70208	Reel Motor
85	45202	Terminal Strip 1L-3P(L)
86	58505	Index Counter
87	27199	Counter Retainer
88	27142	Counter Belt
89	44324	Tension Switch
90	11130	Face Plate
91	11133	Transport Chassis
92	14120	Roller Arm Shaft
93	41503	Lamp Holder
94	41413	Lamp
95	25110	Speed Selector Button
96	25160	Speed Selector Switch Lever
97	27048	Rubber Grommet
98	44321	Power Switch
99	27200	Power Switch Holder
100	13011	Head Ass'y
120	13325	Head Housing
121	13336	Head Housing Face Plate
125	11131	Sash A
126	11132	Sash B
209	11691	Stiffener
7	12233	Motor Pulley
8	12225	Capstan Drive Belt
11	12196	Dust Cap
12	12231	Capstan Base
15	15007	Tape Lifter Ass'y

25	14009	Pinch Roller Ass'y
26	14142	Roller Arm
27	15173	Pinch Roller Link Arm
50	17003	Brake Mounting Base Ass'y
400	44323	Transport Selector Switch Ass'y

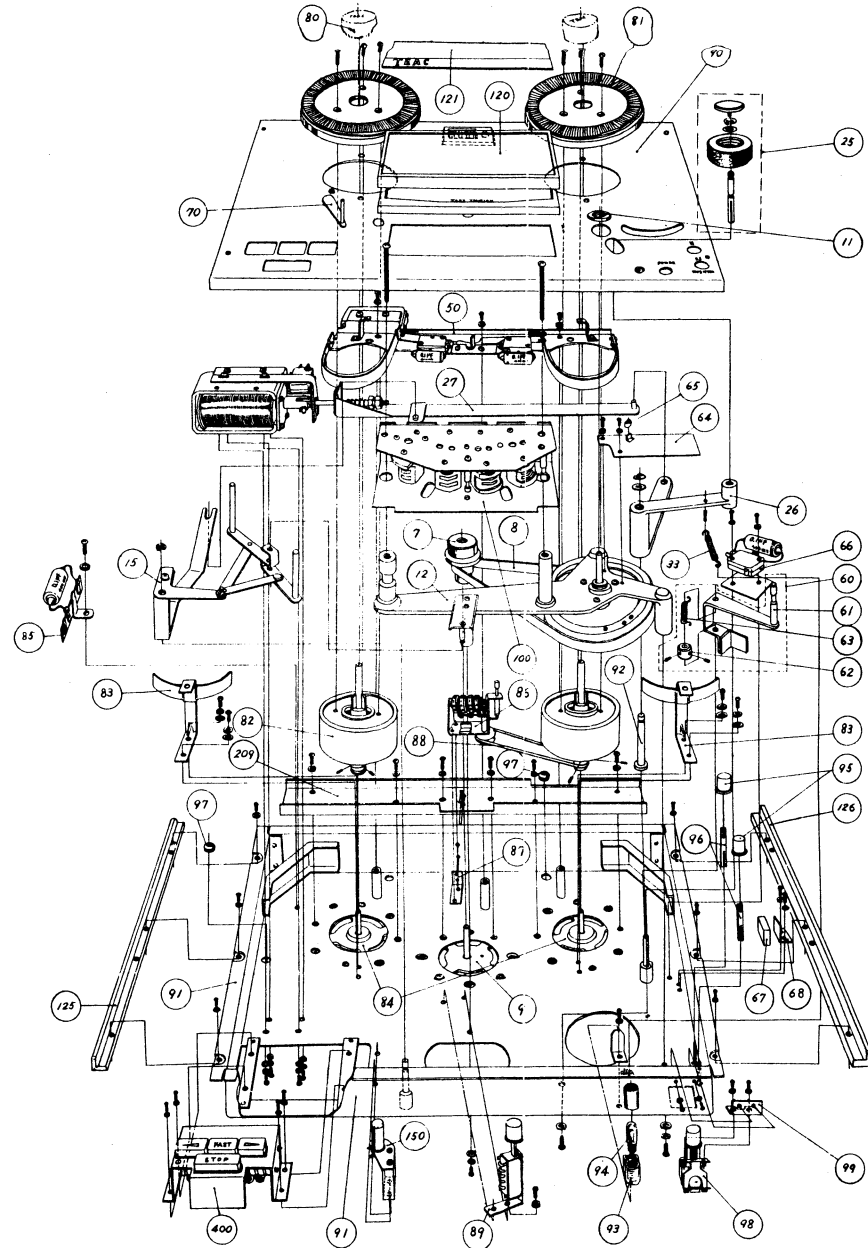

A-4000 FIG. 1 TRANSPORT--TOP, EXPLODED VIEW

FIG. 3 BACK PLATE ASS'Y

REF. NO.	PART NO.	DESCRIPTION
600	23126	Back Cover
601	41207	Fuse Post
602	41114	Fuse 2A
603	43434	Socket 11P
604	43414	Socket 7P
605	43614	Connector 18P
606	43439	Pin Jack
607	43406	GT Socket
608	43105	AC Receptacle
609	27189	Leg
610	40020	Pre-amplifier Ass'y
611	44212	Voltage Select Switch
612	44407	Cycle Select Switch
614	27016	Rubber Cushion
		Transistor 2SB257
		" 2SA49
		" 2SB189
		" 2SB200

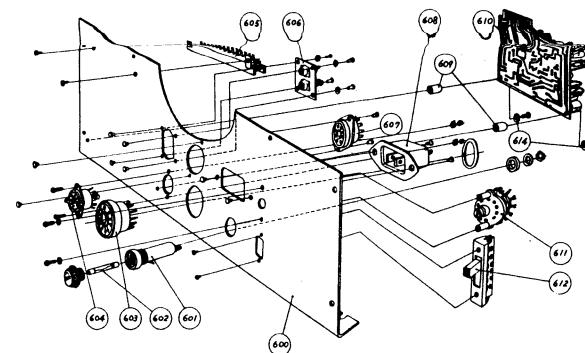

A-4000 FIG. 3 BACK PLATE ASS'Y, EXPLODED VIEW

FIG. 4 LEFT CHASSIS ASS'Y

REF. NO.	PART NO.	DESCRIPTION
613	23114	Left Chassis
614	27189	Rubber Cushion
615	48804	Relay Printed Board Ass'y

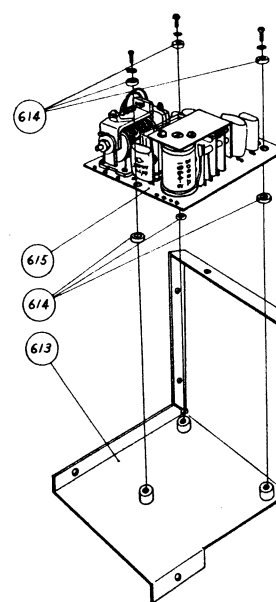

A-4000 FIG. 4  
LEFT CHASSIS ASS'Y, EXPLODED VIEW

FIG. 5 RIGHT CHASSIS ASS'Y

REF. NO.	PART NO.	DESCRIPTION
614	27016	Rubber Cushion
616	23115	Right Chassis
617	55108	Capacitor 100MF/150V Electrolytic
618	55102	Capacitor 1000MF/50V Electrolytic
619		Round Head Screw M4x70
620		Bakelite Washer M4
621	52208	Resistor 1k $\Omega$ 20 W Wire Wound
622		Spring Washer M4
623		Earth Terminal M4
624		Flat Washer M4
625		Nut M4
626	48803	Power Supply Printed Board Ass'y

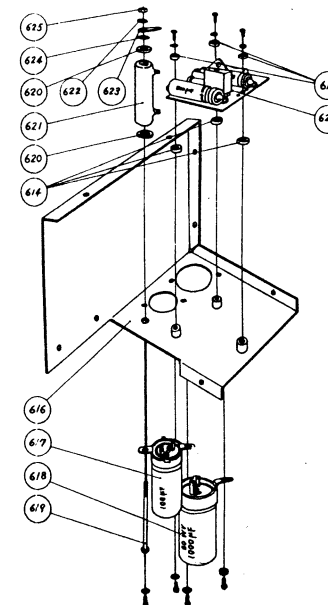

A-4000 FIG. 5  
RIGHT CHASSIS ASS'Y, EXPLODED VIEW

FIG. 2 TRANSPORT--BOTTOM

REF. NO.	PART NO.	DESCRIPTION
9	70111	Capstan Motor
10	12228	Fan
84	70208	Reel Motor
91	11133	Transport Chassis
97	27048	Rubber Grommet
200	56119	Power Transformer
201	27198	Resistor Retaining Plate
202	52416	Tape Tension Adjust Resistor 250Ω 30W
203	52407	Back Tension Adjust Resistor 400Ω 30W
204	44325	Speed Selector Switch
205	54009	Capacitor Ass'y (Capacitor 0.1MF Tubular)
206	54528	Capacitor 2.8M+1M / 250V MP
207	54526	Capacitor 2.5M+0.5M / 250V MP
208	54012	Capacitor Ass'y (Capacitor 0.1MF Tubular)
400	44323	Transport Selector Switch Ass'y
600	23126	Back Cover
613	23115	Left Chassis
615	48804	Relay Printed Board Ass'y
616	23114	Right Chassis
626	48803	Power Supply Printed Board Ass'y

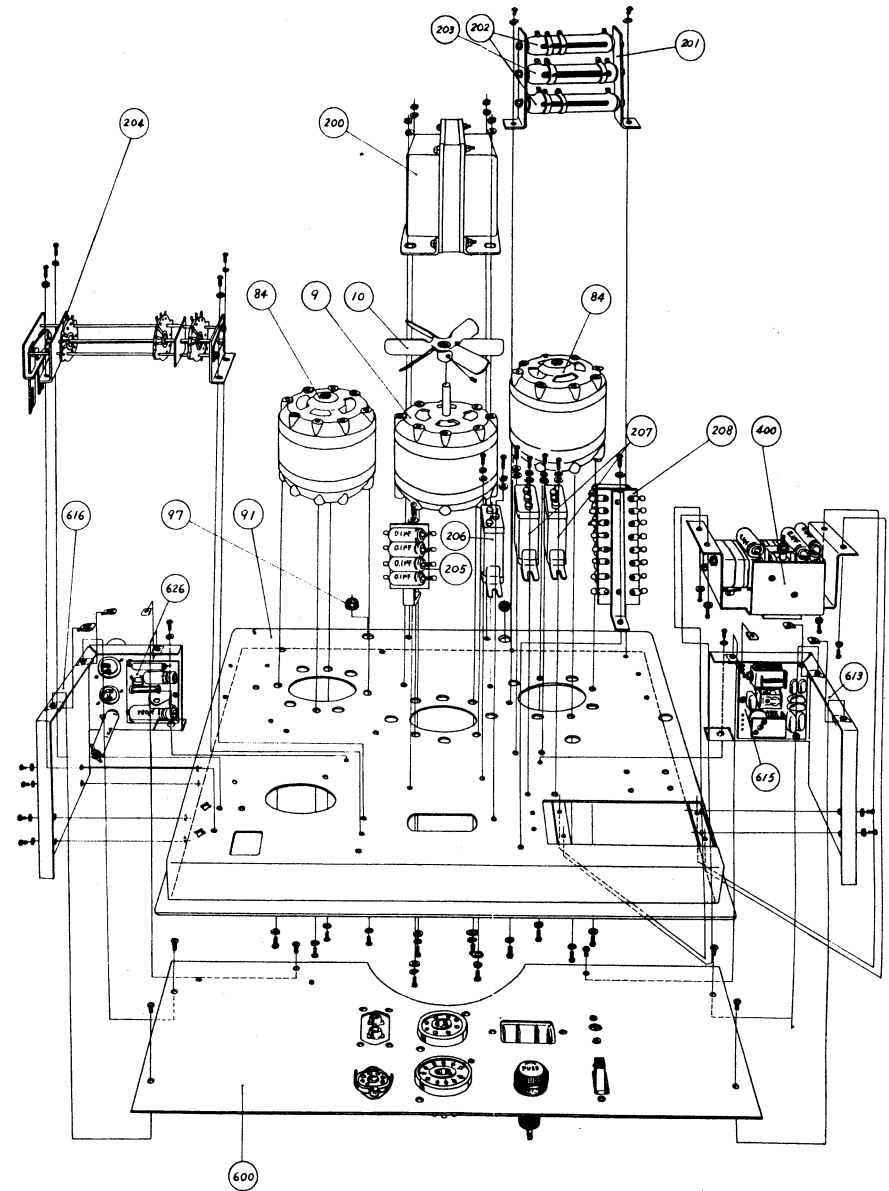

A-4000 FIG. 2 TRANSPORT--BOTTOM, EXPLODED VIEW

FIG. 7 CAPSTAN AND TAPE LIFTER ASS'Y

REF. NO.	PART NO.	DESCRIPTION
1	12005	Capstan Shaft Ass'y
2	12232	Capstan Shaft
3	12238	Capstan Housing
4	12240	Metal Bearing
5	27166	Bearing Washer
6	12166	Flywheel
12	12231	Capstan Base
13	13333	Housing Leg
14	13335	Tape Guide
15		Tape Lifter Ass'y
16	15160	Lifter A
17	15161	Lifter B
18	15142	Lifter Retaining
702		E-clip M2
703		" M3

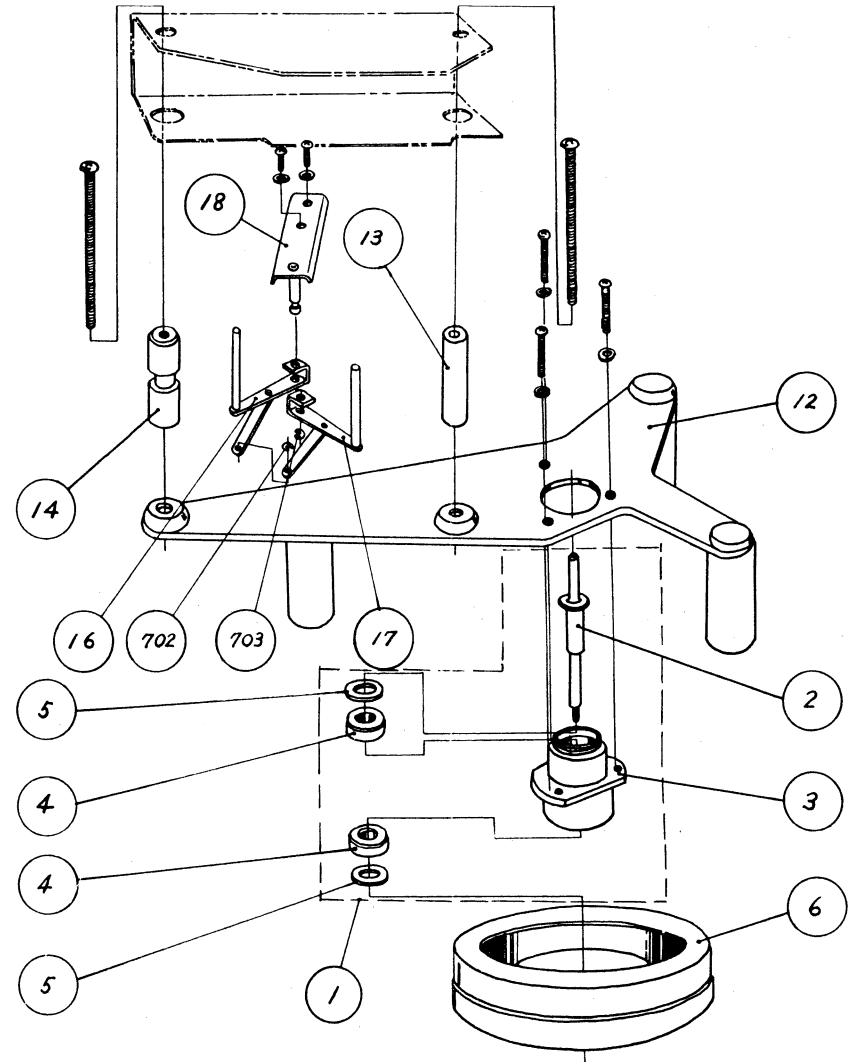

A-4000 FIG. 7 CAPSTAN AND TAPE LIFTER ASS'Y, EXPLODED VIEW

FIG. 6 TRANSPORT SELECTOR SWITCH ASS'Y

REF. NO.	PART NO.	DESCRIPTION
400	44323	Transport Selector Switch Ass'y
405	44939	Switch Mounting Chassis
406	21004	Special Screw M3x95
407	24053	Leg
408	44610	Micro-switch
409	44613	"
410	54102	Capacitor 0.1MF Tubular
411	44614	Micro-switch
412	44936	Push Plate Ass'y
413	44935	" "
414	44940	" "
415	29187	Cushion
416	44932	SV Solenoid Retaining
417	61615	SV Solenoid
418	TC 19	Leg
419	21544	Flat Washer M4
420		Spring Washer M4
421		Nut M4
401	27186	Rubber Sheet
402	25215	Direction Button
403	25216	Fast Button
404	25208	Stop Button

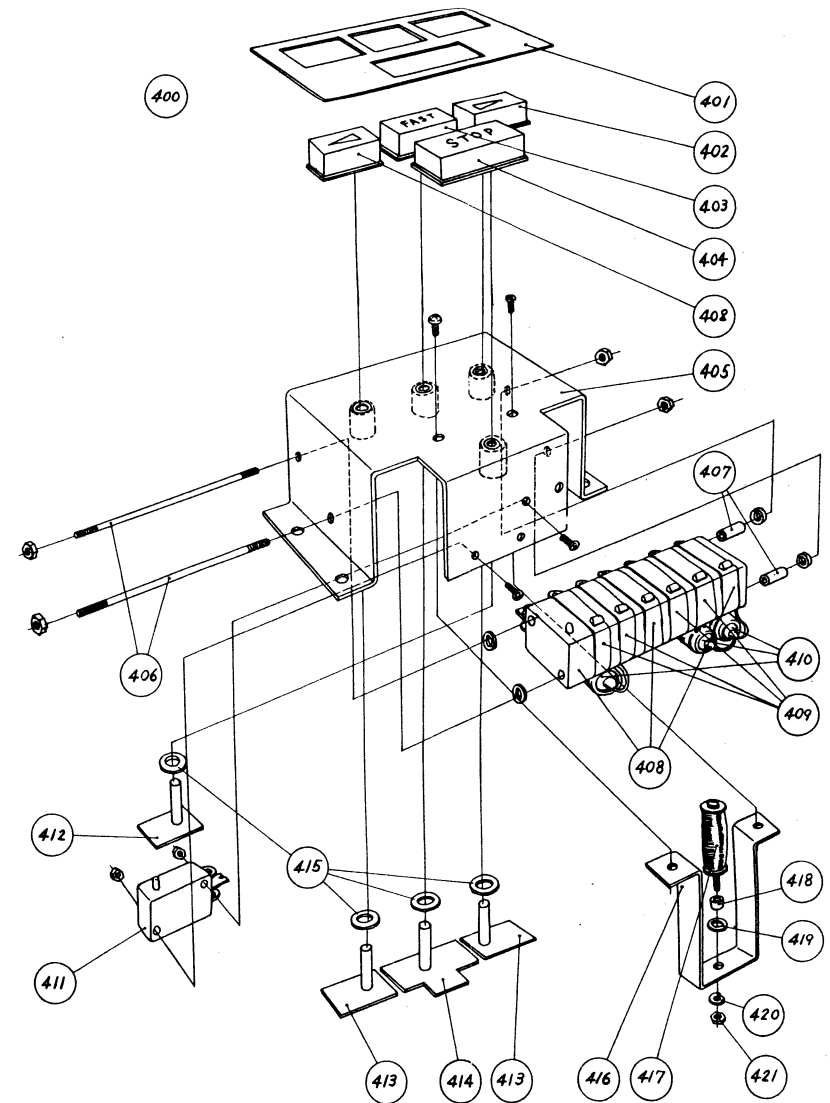

A-4000 FIG. 6 TRANSPORT SELECTOR SWITCH ASS'Y, EXPLODED VIEW



FIG. 9 TAPE LIFTER AND PINCHROLLER  
LINK ARM ASS'Y

REF. NO.	PART NO.	DESCRIPTION
15	15007	Tape Lifter Ass'y
16	15160	Lifter A
17	15161	Lifter B
18	15142	Lifter Retaining Plate
702		E-clip M2
703		" M3
12	12231	Capstan Base
19	15141	Lifter Lever
20	15169	Lifter Arm
26	14142	Roller Arm
27	15173	Pinch Roller Link Arm
28	14113	Double Nut A 4mm
29	14110	" B 4mm
30	22004	Pressure Spring
31	12153	Pressure Adjust Screw
32	14135	Stopper
33	22036	Spring
704		E-clip M4
705		" M5
710		Fiber Washer M7
800	27152	Felt Washer
814		Flat Washer M4
58	61617	Solenoid Ass'y
59	12155	Pin A
813		Flat Washer M3
751		Pin M1
40	14141	Micro-switch Retaining Plate
41	44610	Micro-switch

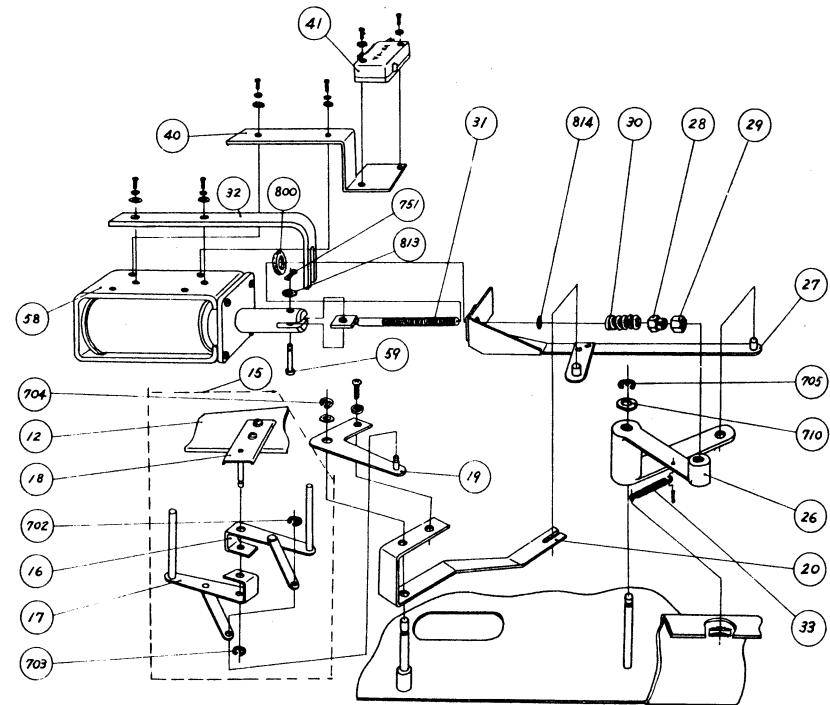

A-4000 FIG. 9 TAPE LIFTER AND PINCH ROLLER LINK ARM ASS'Y, EXPLODED VIEW

FIG. 8 SENSING POST ASS'Y

REF. NO.	PART NO.	DESCRIPTION
150	44941	Sensing Post Ass'y
151	44925	Sensing Cap
152		Screw M3x35
153	44915	Sensing A
154	44920	Insulation Bushing
155	44916	Sensing B
156	44923	Terminal
157	44917	Sensing Sleeve
158	44928	Insulation Washer
159	44918	Sensing Retaining Plate
160		Insulation Washer M3
161		Terminal M3
162	21583	Spring Washer M3
163		Nut M3
164	44934	Sensing Retaining Base

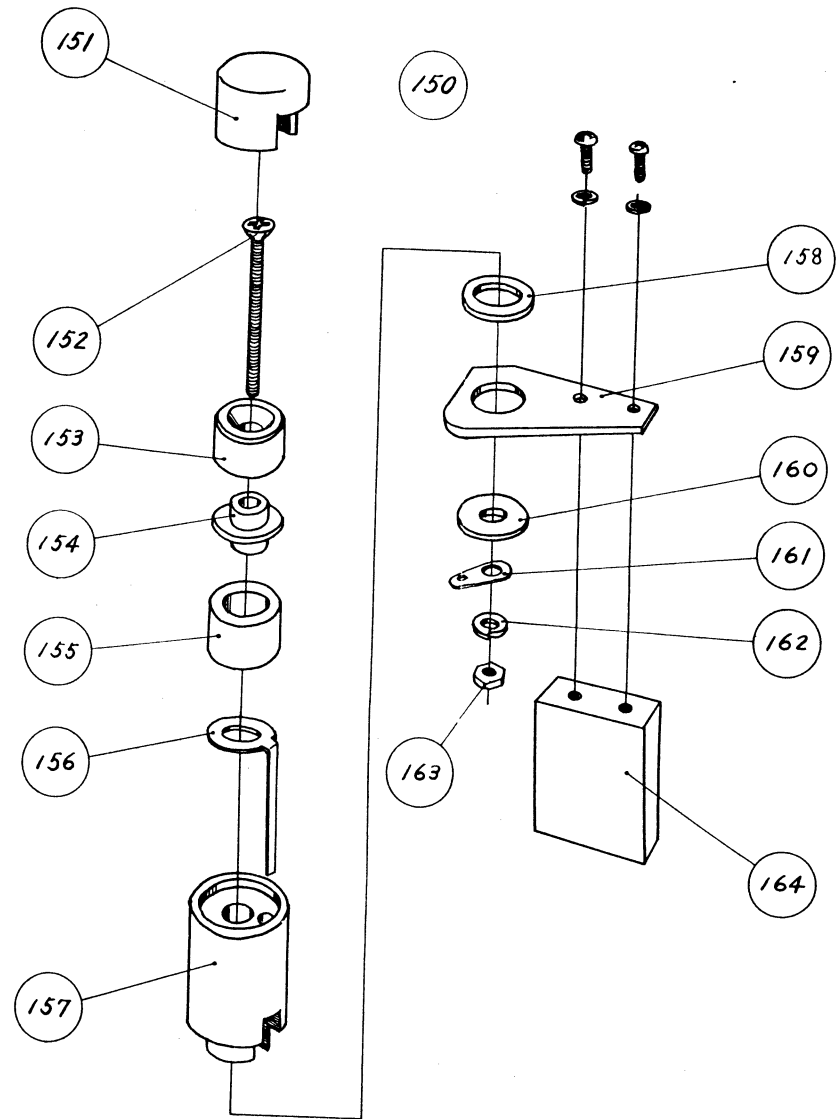

A-4000 FIG. 8 SENSING POST ASS'Y, EXPLODED VIEW

FIG. 11 FACE PLATE ASS'Y

REF. NO.	PART NO.	DESCRIPTION
70	18020	Tension Arm Ass'y
71	18021	Tension Arm
72	18182	Arm Holder
73	27181	Rubber Cushion
74	18197	Tension Arm Base
75	18167	Limiter
76	18187	Arm Holder Nut
77	18133	Spring Hook
78	18198	Spring Retaining Drum
79	22041	Tension Arm Spring
21	27181	Counter Escutcheon
22	27180	Pilot Lamp Cap
23		Gum Tape
90	11130	Face Plate

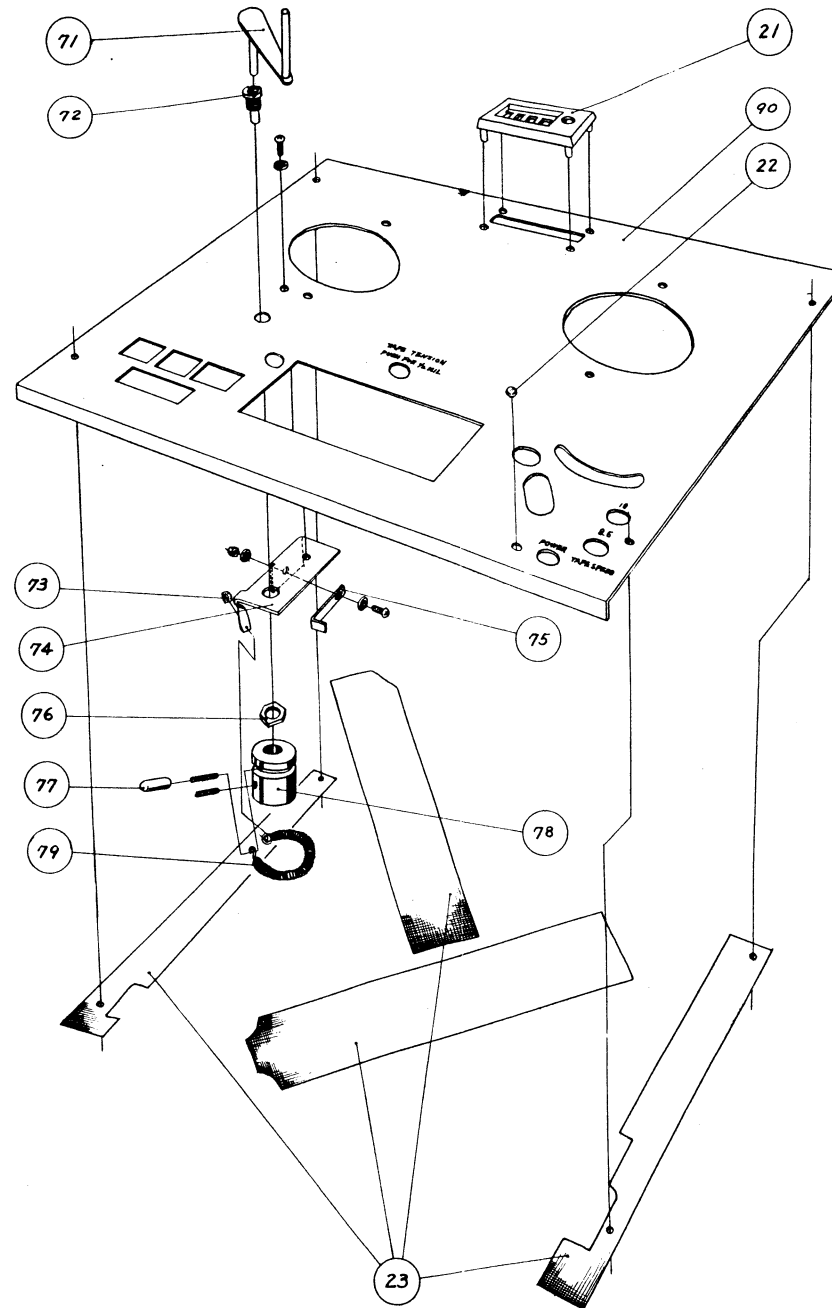

A-4000 FIG. 11 FACE PLATE ASS'Y, EXPLODED VIEW

FIG. 10 BRAKE ASS'Y

REF. NO.	PART NO.	DESCRIPTION
35	17001	Brake Band Ass'y
36	17191	Brake Band
37	17138	Brake Felt
50	17199	Brake Mounting Base Ass'y
51	17200	Brake Mounting Base
52	17201	Brake Lever A
53	17202	" B
54	17190	Left Brake Spring
55	17189	Right Brake Spring
56	17180	Brake Band Retainer
57		Vinyl Pipe
38	17203	Micro-switch Retaining Plate
39	27179	Insulation Plate
42	44613	Micro-switch
45	54102	Capacitor 0.1MF
58	61617	Solenoid Ass'y
59	12155	Pin A
813		Flat Washer M3
751		Pin M1

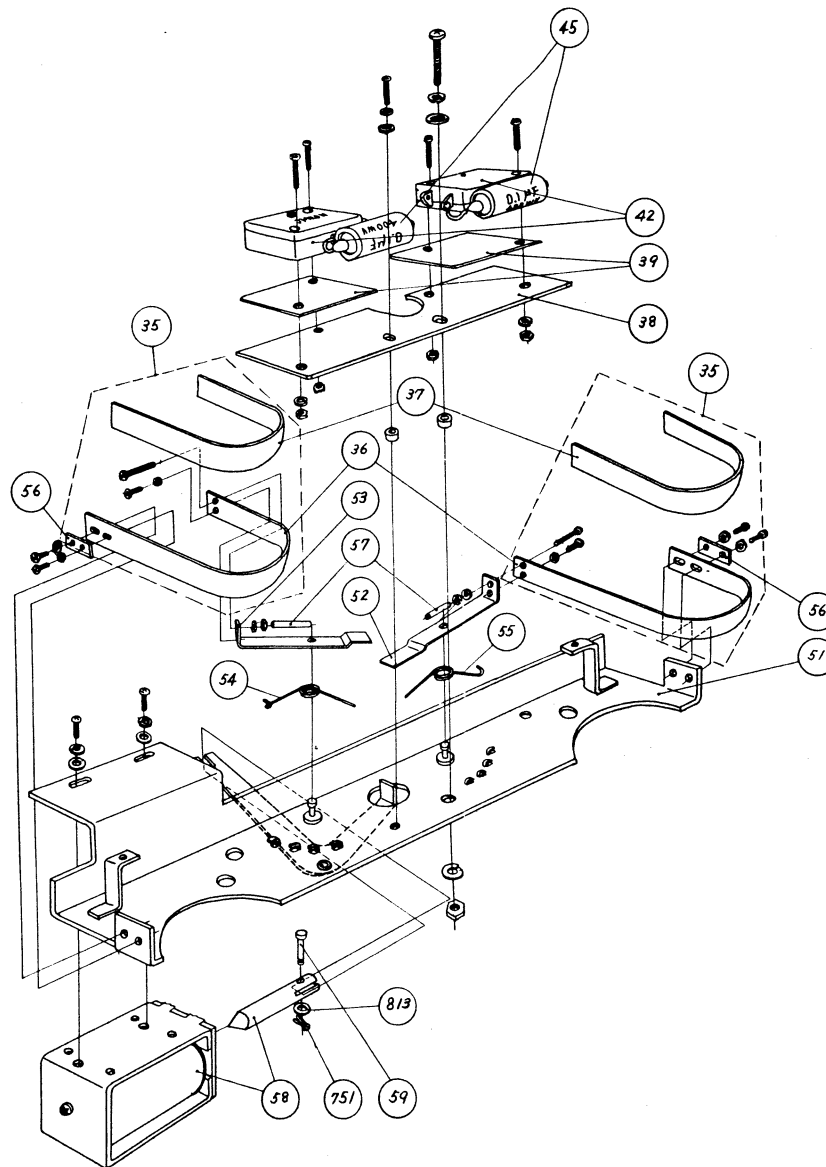

A-4000 FIG. 10 BRAKE ASS'Y, EXPLODED VIEW

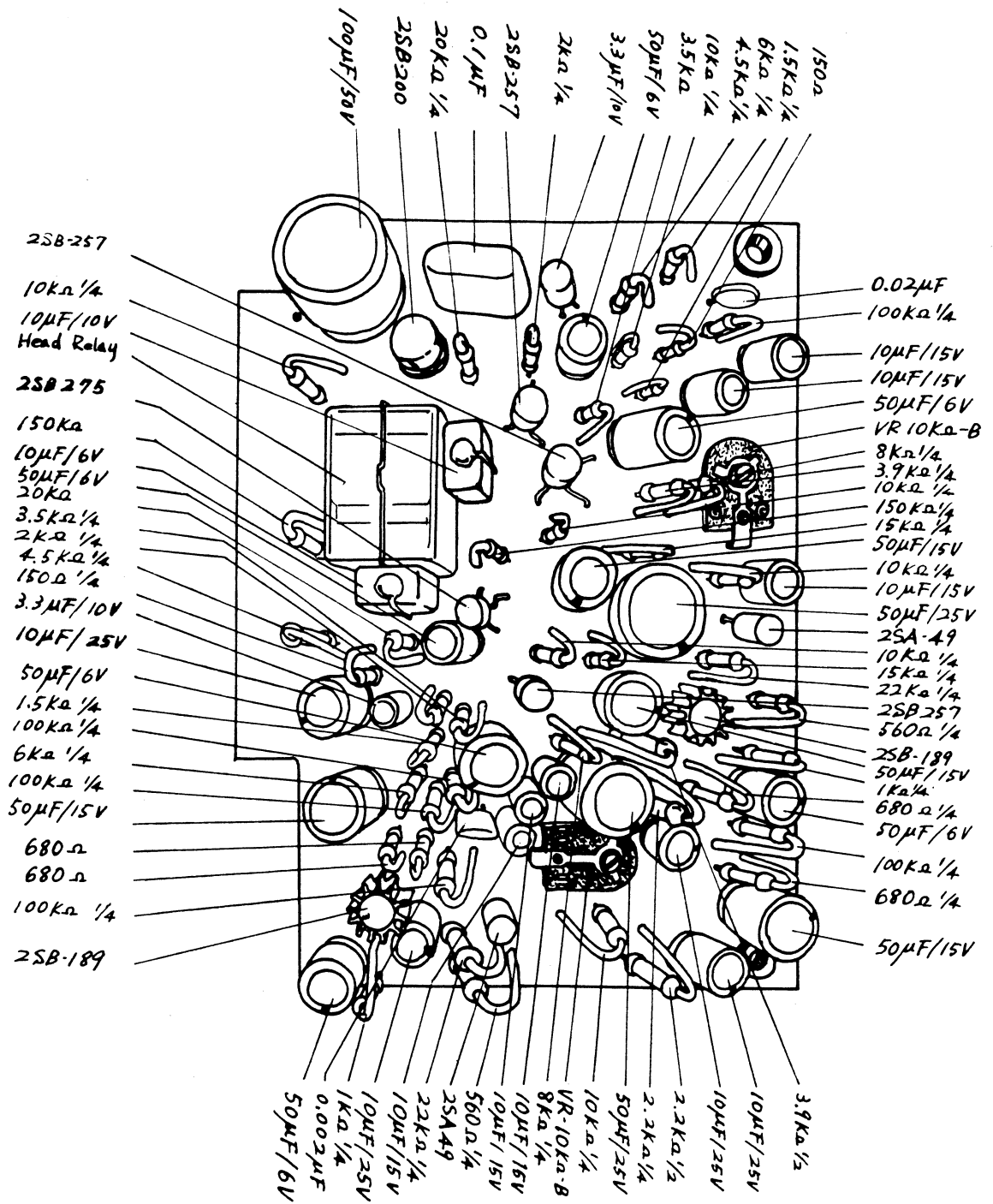

A-4000 FIG. 13 PREAMPLIFIER CIRCUIT BOARD

FIG. 12 HEAD ASS'Y

REF. NO.	PART NO.	DESCRIPTION
100	13011	Head Ass'y
101	66601	Record Head
102	66901	Playback Head
103	66303	Erase Head
104	13317	Head Base Plate
105	13323	Bottom Shield Plate
106	13319	Head Mounting Plate A
107	13229	" " B
108	13338	" " D
109	22020	Spring
110	22028	"
111	22042	"
112	13334	Tape Guide
114	24039	Leg
115	13328	Shield Can A
116	13316	" B
117	13333	Housing Leg
118	48031	Printed Terminal Strip 15P

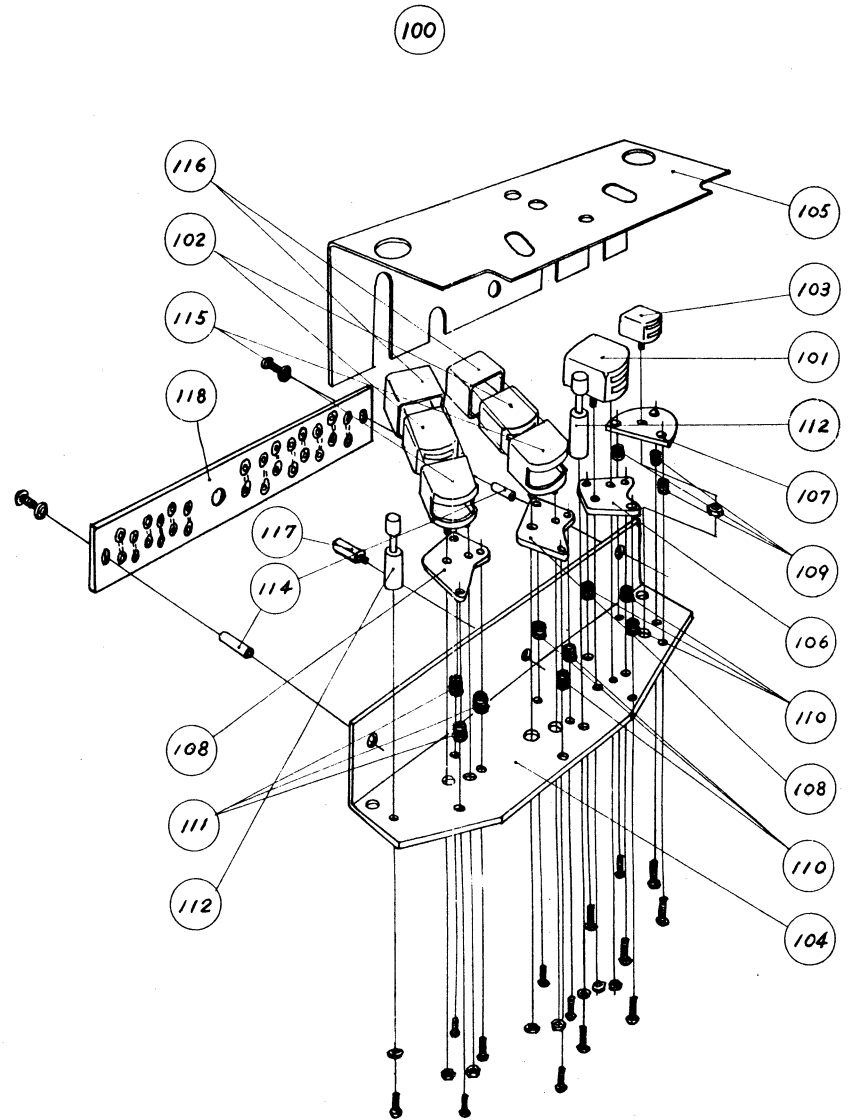

A-4000 FIG. 12 HEAD ASS'Y, EXPLODED VIEW

RA-40 AMPLIFIER

REF. NO.	PART NO.	DESCRIPTION
900	40023	RA-40 Record Amplifier
901	58114	Volume Indicator Meter
902	23131	Face Plate
903	41704	Record Indicator Plate
904		Capacitor 0.005MF
905	45208	Terminal Strip 1L-1P
906		Resistor 3.6 kΩ 1/4W Carbon
907	23135	Face Chassis
908	43010	Jack
909	53706	Double Potentiometer 10 kΩ Carbon
910		Choke Coil Retainer
911	56603	Choke Coil
912	27205	Pilot Lamp Retainer
913	41503	Pilot Lamp Socket
914	44608	Micro-switch
915		
916	44407	Monitor Selector Switch
917	43418	Jack
918	23138	Micro-switch Retainer
919	23136	Left Chassis
920	23139	Connector Retainer
921		
922	43438	Connector 10P
923	43614	" 18P
924	48808	Record Printed Board Ass'y
925	48811	Meter Printed Board Ass'y
926	23136	Right Chassis
927	56122	Power Transformer
928	55111	Capacitor 1000MF 50V Electrolytic
929	52505	Resistor 1kΩ 2W
930	23137	Back Chassis
931	43424	Socket 7P
932	43001	DIN Connector
933	43437	GT Plug
934	41207	Fuse Post
935	41101	Fuse 1A
936	43439	Pin Jack
937		Resistor 100 kΩ 1/4W
938	45206	Terminal Strip 1L-2P
939	27210	Connector Retainer
940	27209	Printed Board Retainer
941	27200	" "
942	27207	" "
943	23141	" "

944	48041	Relay Printed Board Ass'y
945	48809	Oscillator Printed Ass'y
946	23142	Power Transistor Heat Sink
947	23143	Sash
950	25217	Knob (Inner)
951	25218	" (Outer)
952	23144	Record Button Protector
953		Record Button
955		M3 Screw
614	27016	Rubber Cushion
		Transistor 2SB257
		" 2SB189
		" 2SB94
		" 2SB425
		" 2SB200
		" 2SB439
		" 2SA49

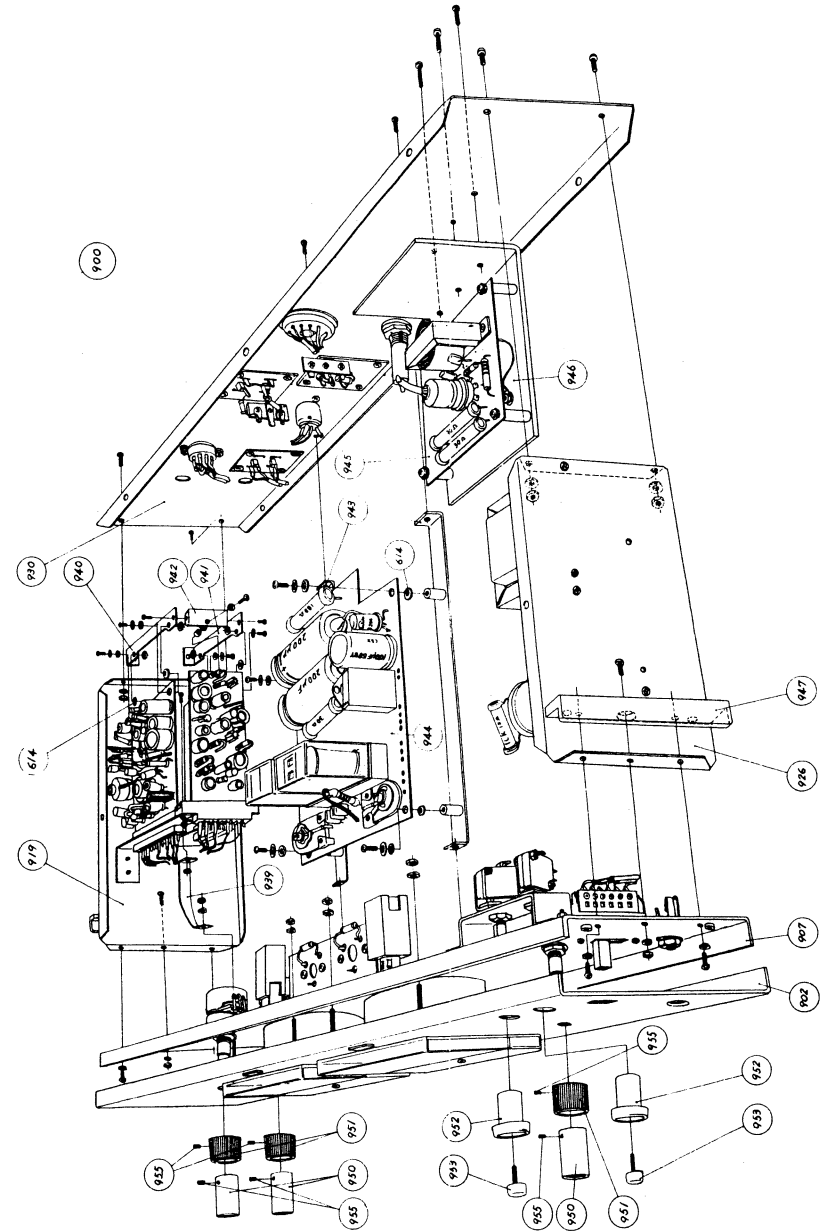

RA-40 FIG. 1 AMPLIFIER, EXPLODED VIEW

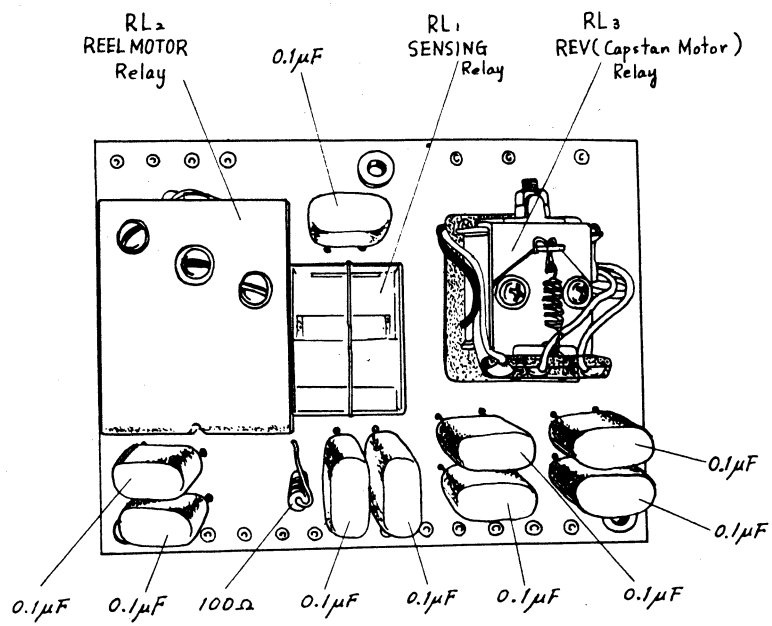

A-4000 FIG. 14 RELAY CIRCUIT BOARD

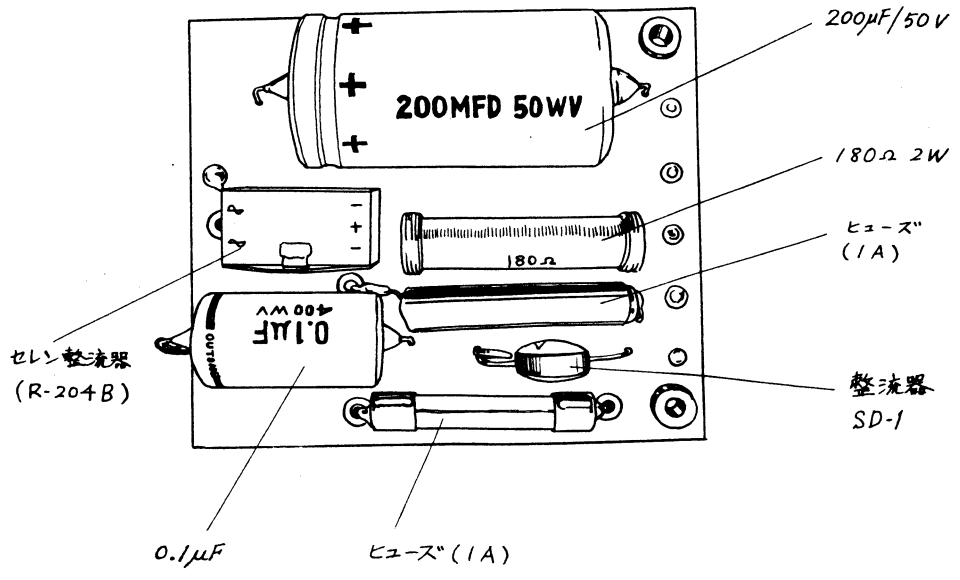

A-4000 FIG. 15 POWER SUPPLY CIRCUIT BOARD



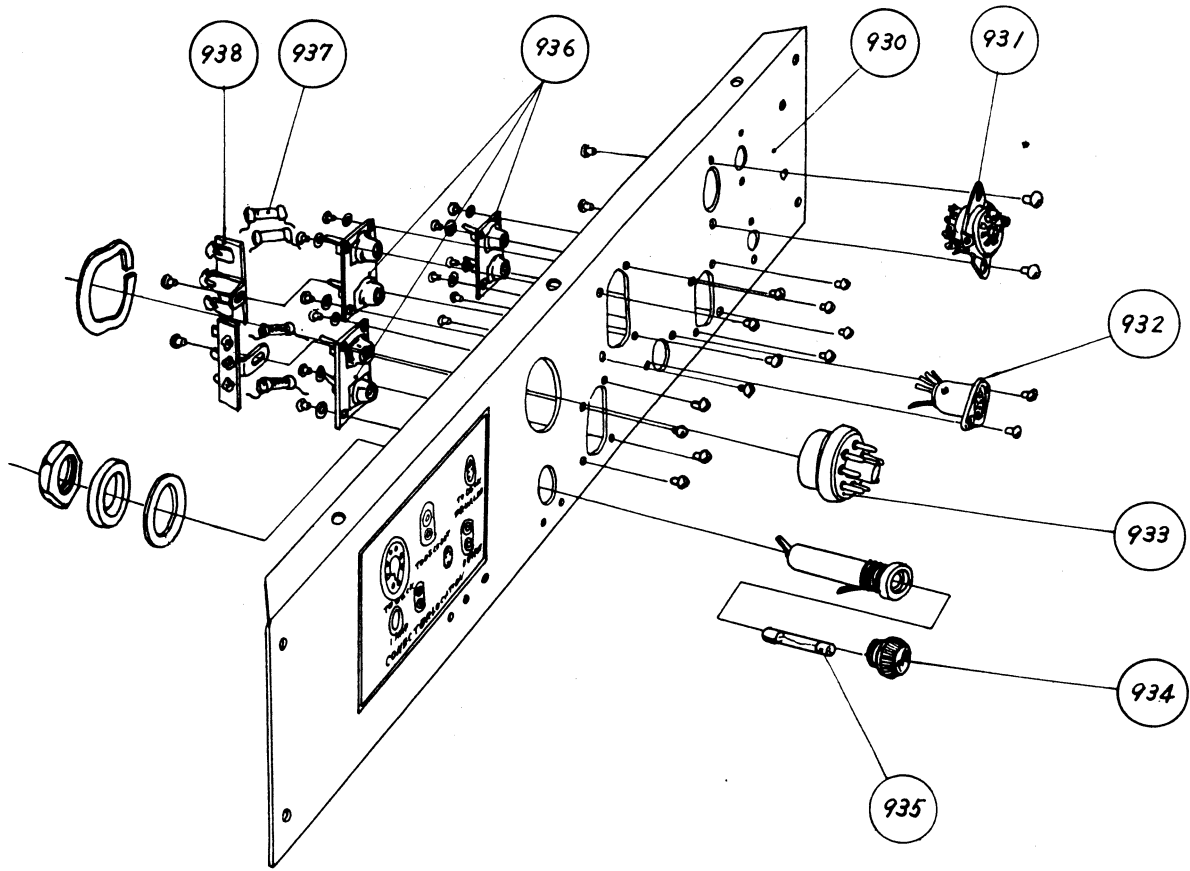

RA-40 FIG. 6 BACK CHASSIS ASS'Y, EXPLODED VIEW

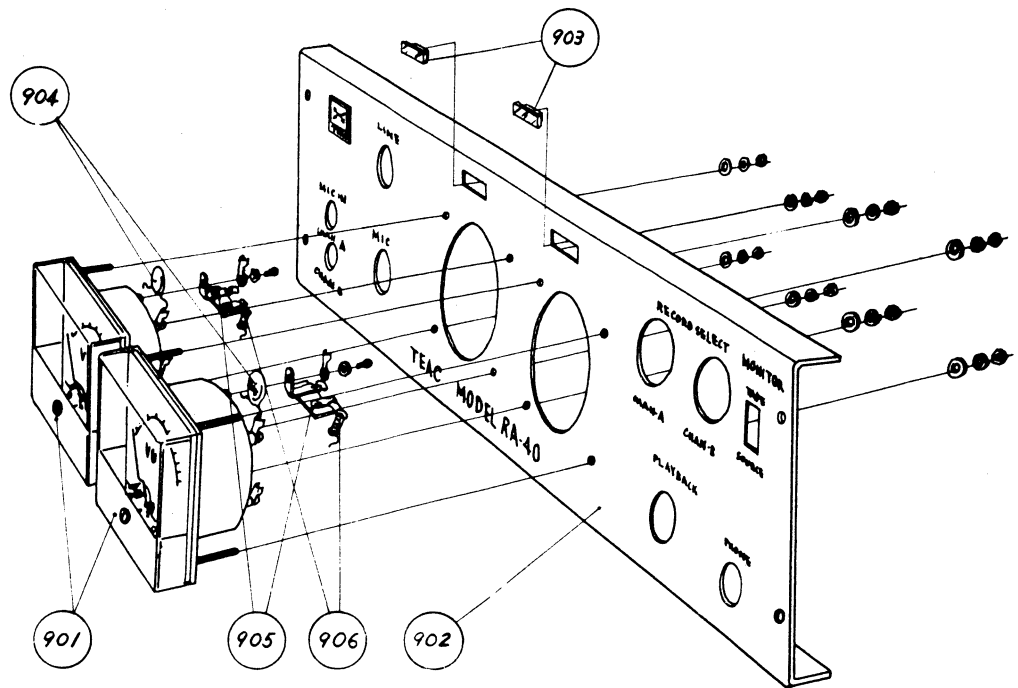

RA-40 FIG. 2 FACE PLATE ASS'Y, EXPLODED VIEW

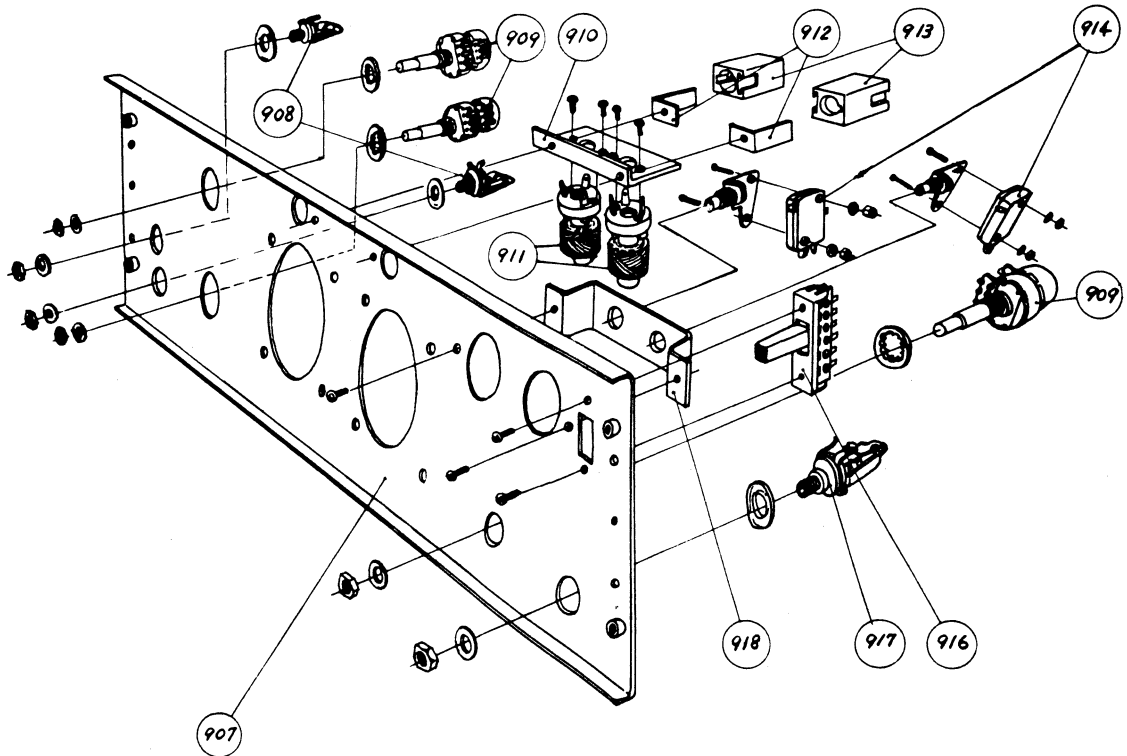

RA-40 FIG. 3 FACE CHASSIS ASS'Y, EXPLODED VIEW

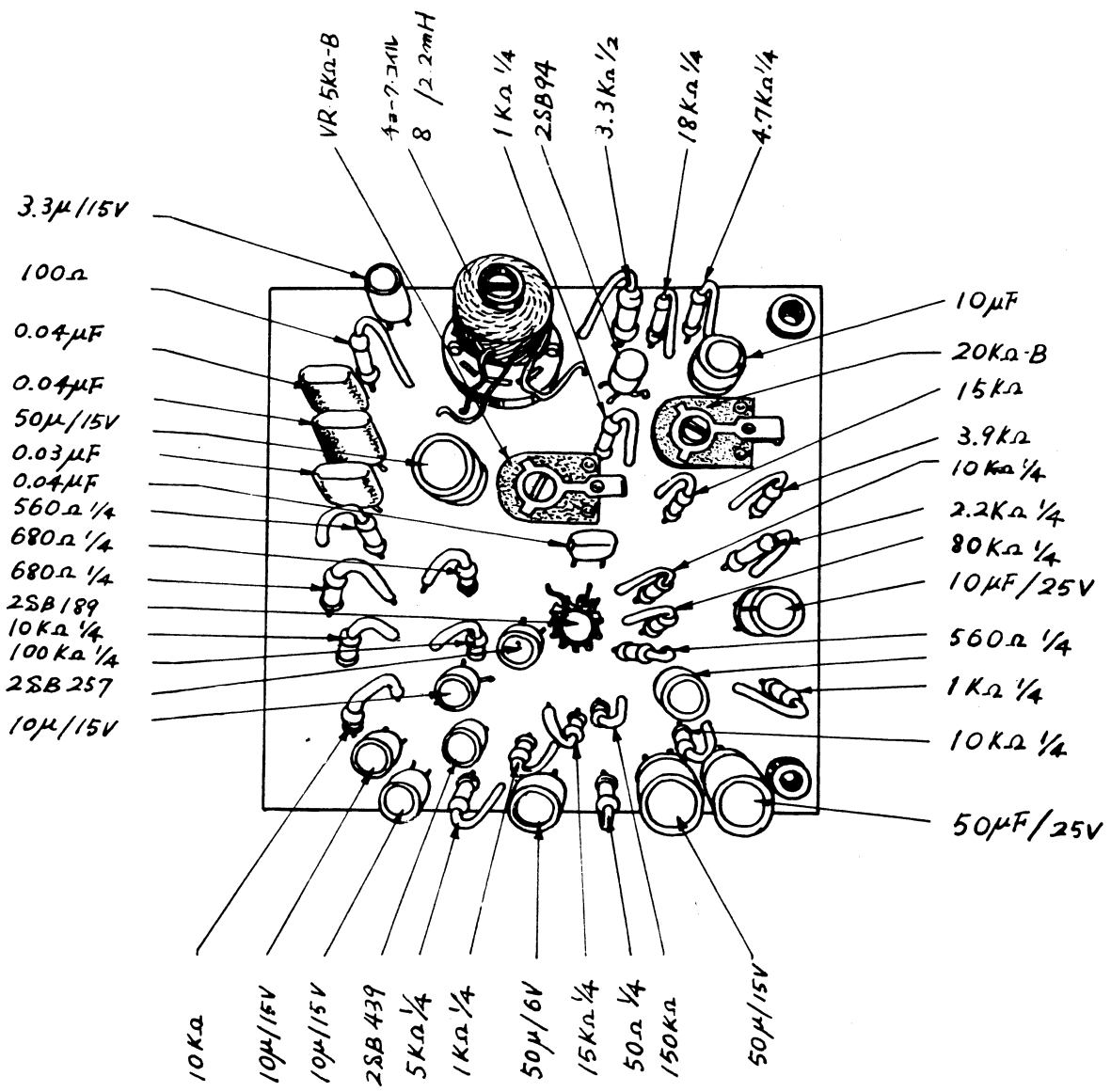

RA-40 FIG. 7 RECORD AMPLIFIER CIRCUIT BOARD

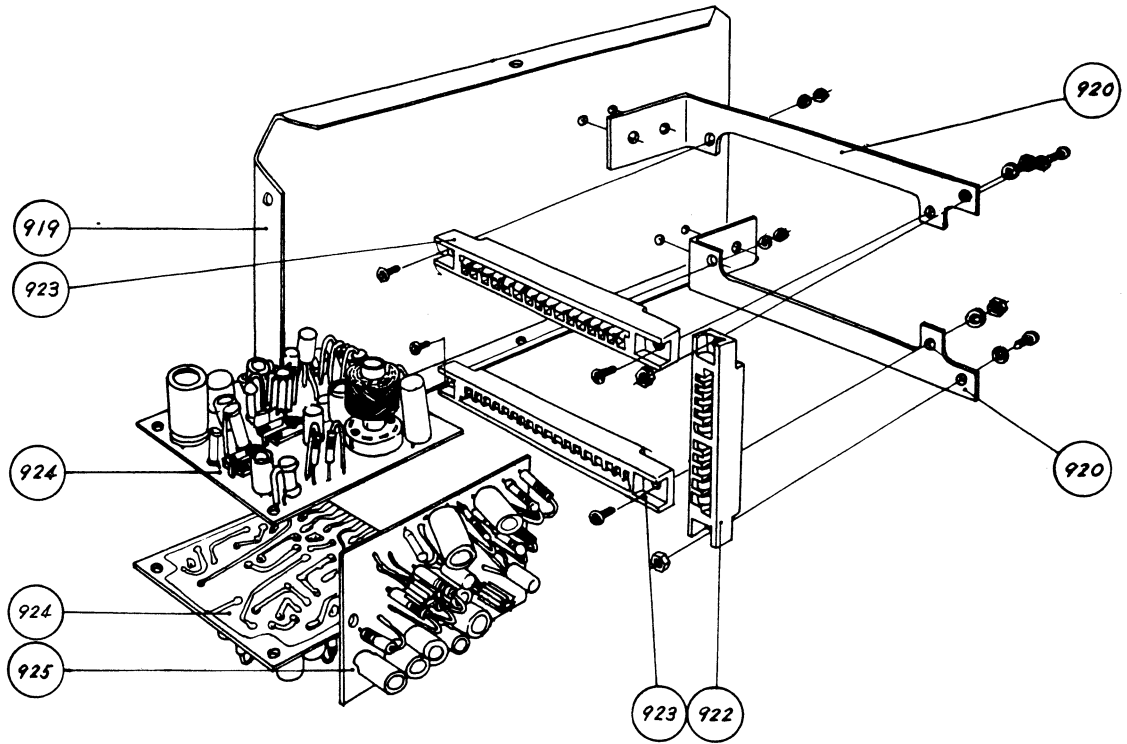

RA-40 FIG. 4 LEFT CHASSIS ASS'Y, EXPLODED VIEW

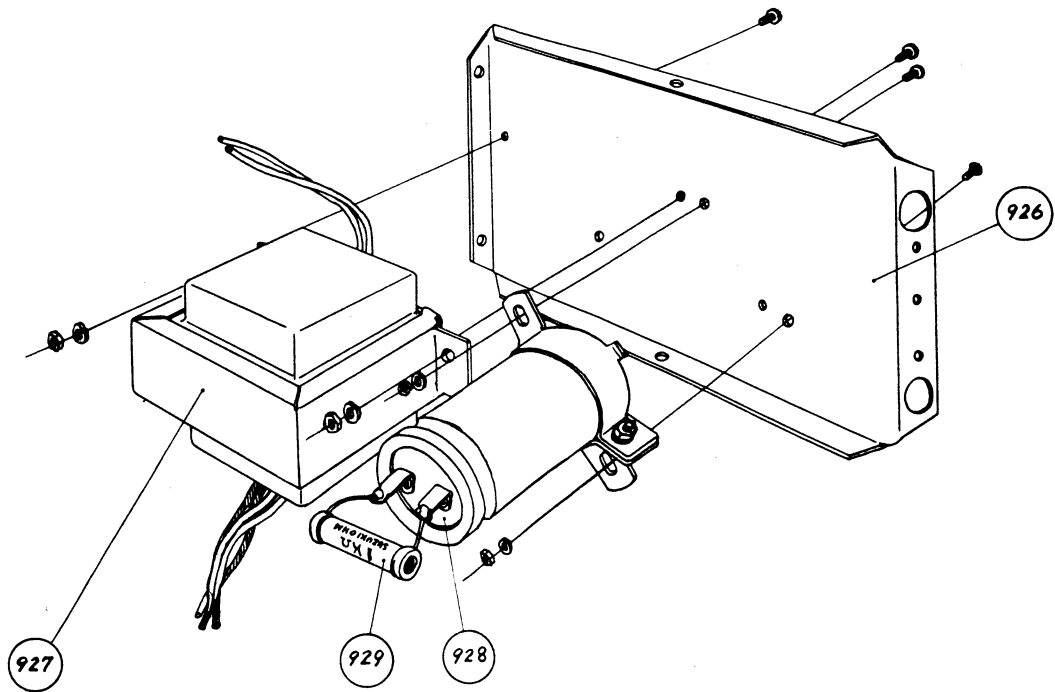

RA-40 FIG. 5 RIGHT CHASSIS ASS'Y, EXPLODED VIEW

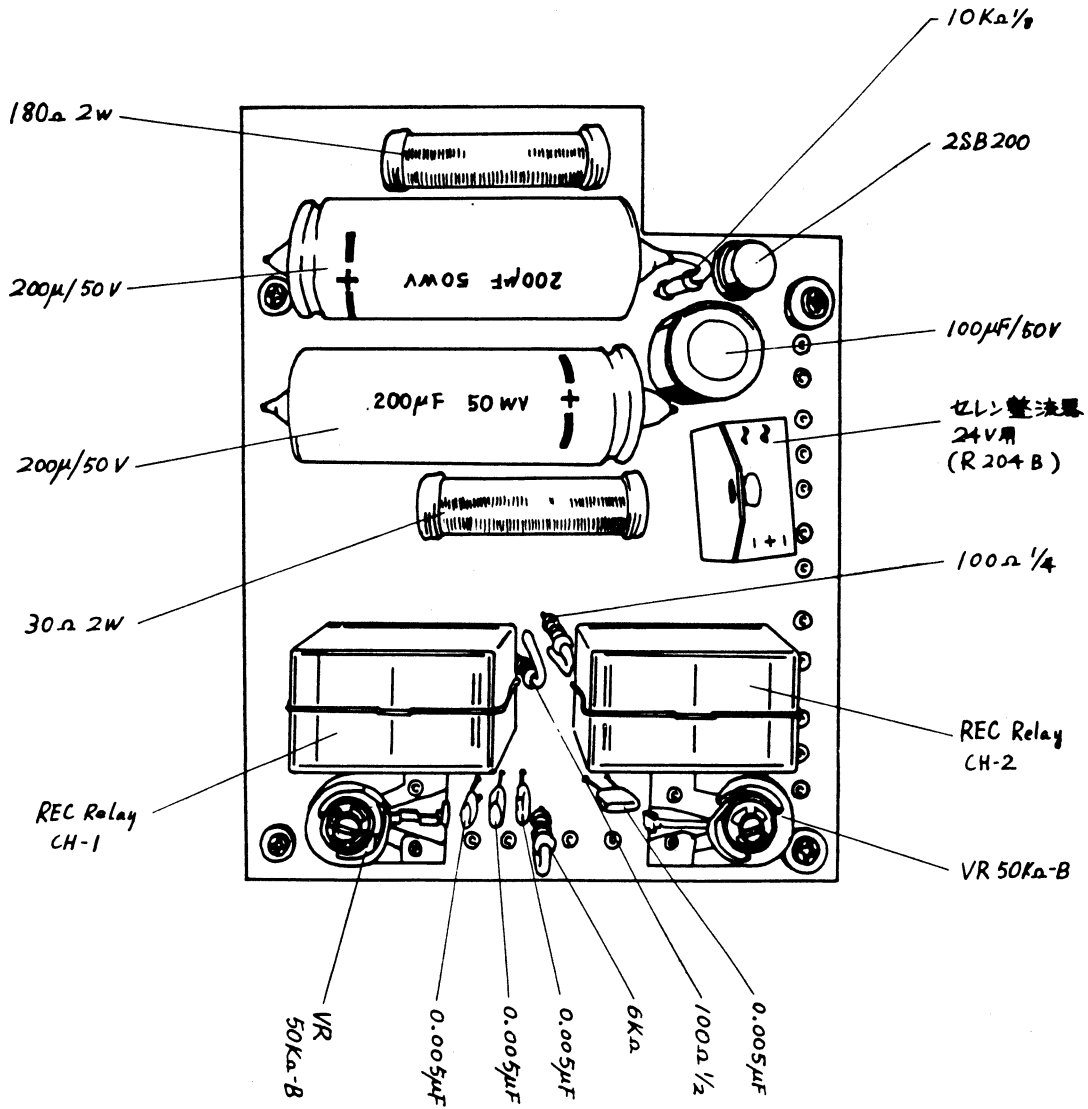

RA-40 FIG. 10 RELAY CIRCUIT BOARD

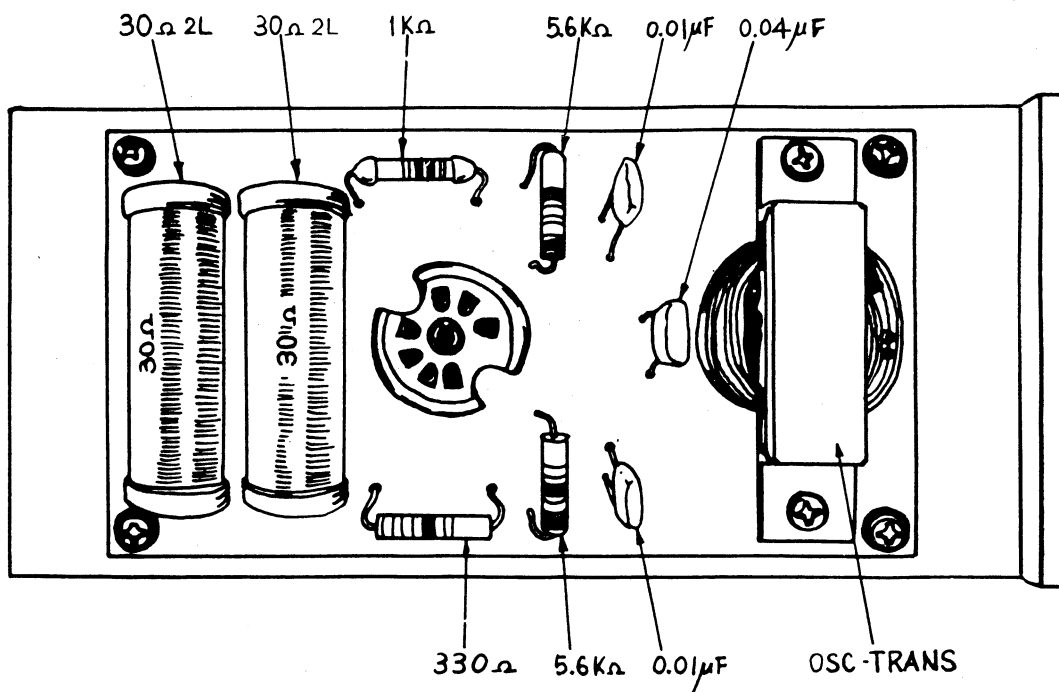

RA-40 FIG. 9 BIAS OSCILLATOR CIRCUIT BOARD

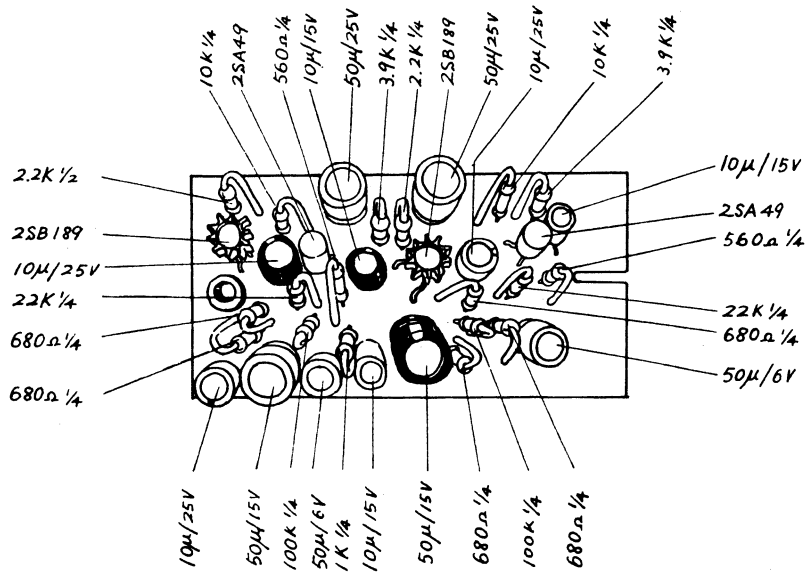

- I -

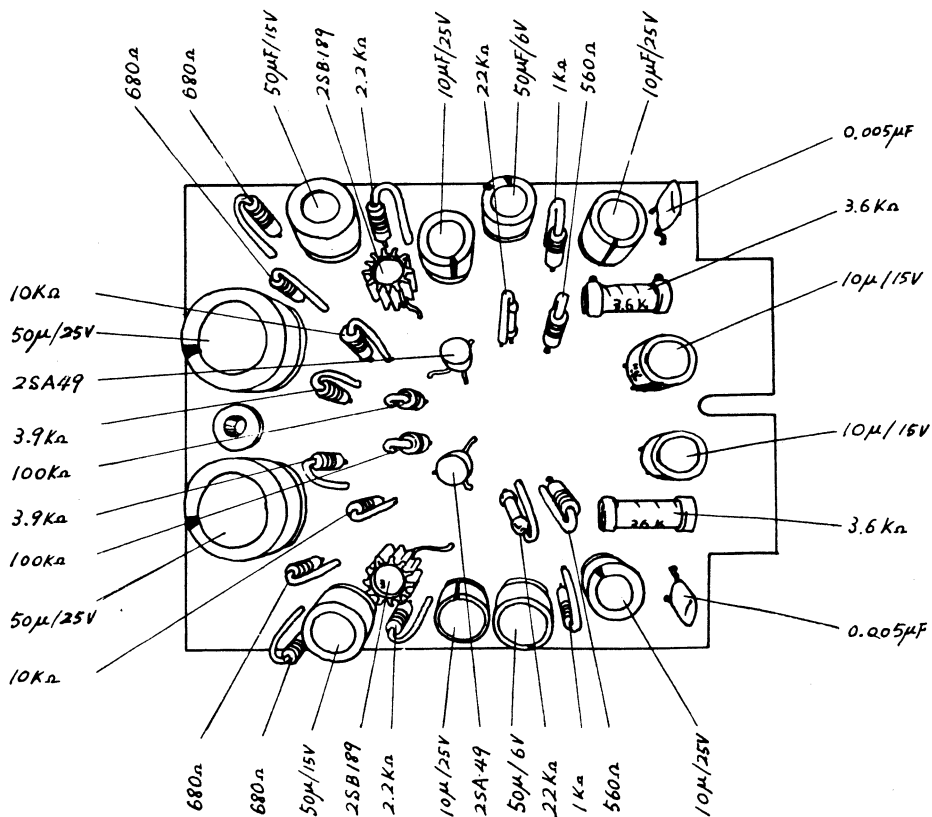

- II -

RA-40 FIG. 8 OUTPUT AMPLIFIER CIRCUIT BOARD

RA-40 FIG. 10 RELAY CIRCUIT BOARD

