



**A-4000S**



**RA-40S**



**A-4010S**

The **TEAC A-4000S** series 4track deck /player is a high quality equipment designed to serve those engaged in sound recording as a profession.

The **A-4000S** series deck /player is available in the following models.

Model **A-4000S** Stereo Player—three motor, four head mechanism with built-in preamplifiers mounted in wooden cabinet.

Model **RA-40S** Record Amplifier—accessory electronics for use with **A-4000S** Tape Player to make complete recorder.

Model **A-4010S** Stereo Tape Deck — factory assembled set of **A-4000S** Tape Player and **RA-40S** Record Amplifier complete with wooden cabinet.

The **TEAC A-4000S** Series deck /player has an extra playback head for automatic reverse play.

It eliminates need for turning the tape over when the end of the reel is reached.

## TABLE OF CONTENTS

WHAT IS FOUR TRACK RECORDER.....	2
FOR THE BEST PERFORMANCE .....	2
CONNECTIONS .....	3
TAPE THREADING .....	6
LOCATION OF CONTROLS .....	7
BASIC OPERATIONS OF CONTROLS .....	9
PLAYING A RECORDED TAPE .....	10
AUTOMATIC REVERSE PLAY.....	11
MAKING A RECORDING .....	12
REMOTE CONTROL.....	14
SOUND ON SOUND/LANGUAGE TRAINING .....	15
ERASING .....	16
MAKING SPLICES.....	16
MAINTENANCE.....	17
VOLTAGE AND FREQUENCY CONVERSION .....	18
REMOVING THE FRONT PANEL .....	18
CUSTOM MOUNTING .....	19
REMOVING THE EQUIPMENT FROM CASE.....	19
SPECIFICATIONS .....	20
SCHEMATIC DIAGRAM.....	44

## WHAT IS FOUR TRACK RECORDER

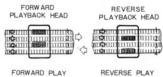
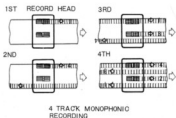
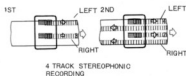
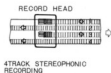
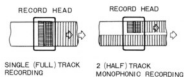

4 TRACK PLAYBACK

There are various ways to make recording on a tape. Four track recording is a method for increasing the recording time to four times that of full track recording.

Full (Single) Track Recording is used mainly at broadcasting companies and recording studios for ease of editing and operation.

Two (Half/Double) Track Recording doubles the recording time. It is used on almost all conventional monophonic tape recorders.

Four (Quarter) Track Recording uses four parallel tracks, each track carrying the recording from a single source. For stereo recording, two tracks are used simultaneously. Where 4 track recording is made, the tracks are designated from 1 to 4 consecutively counting from are top to edge closest to face of recorder.

## FOR THE BEST PERFORMANCE

**TEAC A-4000S** series deck/player can be operated either in horizontal or vertical position.

When operate the equipment in horizontal position or install it into custom cabinet, care must be taken to allow sufficient ventilation of the equipment.

For the best recording/playback performance, the equipment should not be located in the following places for operation.

High temperature of above 100°F.

Direct exposure under the sun.

Near by heating device.

On top of power amplifier case.

Humid or dusty places.

Low temperature of below 40°F.

## CONNECTIONS

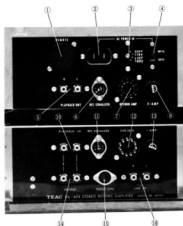

### PLAYER

- ① REMOTE                    Receptacle, Remote control unit
- ② AC POWER IN            Receptacle, AC power
- ③                                Selector, AC power voltage
- ④                                Selector, AC power frequency
- ⑤ PLAYBACK OUT         Jack, Playback output
- ⑥ REC EQUALIZER        Receptacle, Record equalizer cord
- ⑦ RECORD AMP            Receptacle, Record amplifier cord
- ⑧ FUSE 2-AMP             Fuse, 2 amperes

### RECORD AMPLIFIER

- ⑨ PLAYBACK IN         Jack, Playback monitor input
- ⑩ REC EQUALIZER        Receptacle, Record equalizer cord
- ⑪ TAPE DECK             Receptacle, Tape player cord
- ⑫ FUSE 1-AMP            Fuse, 1 ampere
- ⑬ OUTPUT                 Jack, Output
- ⑭ IN/OUT (DIN)         Receptacle, DIN cord
- ⑮ LINE IN                 Jack, Line input



**BEFORE ENERGIZING THE EQUIPMENT** make sure that the settings at the rear-side of the equipment agree with power source voltage and frequency.

The recorder when delivered is normally adjusted to operate on a power source voltage and frequency specified on the carton box.

It should be necessary to convert the recorder to operate from different voltage or frequency, it may be easily accomplished by according to "VOLTAGE AND FREQUENCY CONVERSION," Page 18.

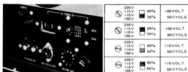

NAME		CODE	CORDS	A-4000S PLAYER	A-4010S TAPE DECK	
AC POWER CORD		A		1	1	
INPUT AND OUTPUT CORD	LEFT CHANNEL	B		1	2	
	RIGHT CHANNEL	C		1	2	
PLAYER -AMP CORD	INPUT AND OUTPUT	LEFT CHAN	D	—	1 *	* These are connected to tape player and record amplifier.
		RIGHT CHAN	E	0	1 *	
	EQUALIZER	F		—	1 *	
POWER SUPPLY AND OTHERS		G		—	1 *	

CONNECTING **A-4000S** TAPE PLAYER TO STEREO AMPLIFIER SYSTEM

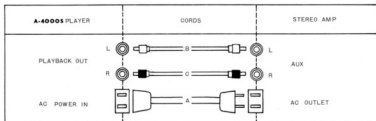
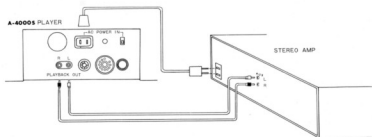

CONNECTING **A-4000S** TO **RA-405** RECORD AMPLIFIER (**A-4010S** INTER-CONNECTIONS)

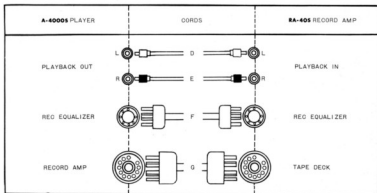

CONNECTING A-40105 TAPE DECK TO STEREO AMPLIFIER SYSTEM

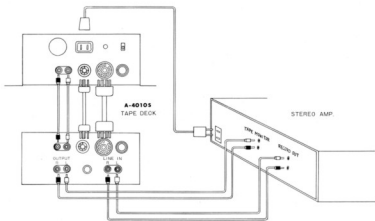

A-40105 TAPE DECK	CORDS		STEREO AMP
AC POWER IN		A	AC OUTLET
LINE IN	L	B	L
	R	C	R
OUTPUT	L	B	L
	R	C	R

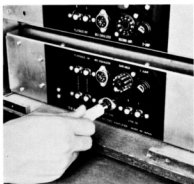

DIN CORD

An optional cord with DIN connectors may be used for interconnecting the recorder and amplifier system by single connection.

*If the use of DIN cord causes insufficient volume level or tone quality, remove the cord and use four cords furnished with the equipment. The mixing operation of microphone and line input signal will not be made when the DIN cord is used.*

## TAPE THREADING

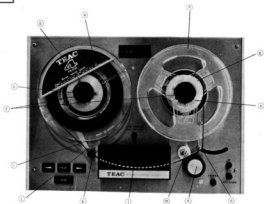

1. Center the reel of tape ② onto the left turntable ①.
2. Press a reel holder over the shaft to secure the reel.

3. Place an empty reel ⑩ of the same diameter as the full one onto the right turntable ⑧.

4. Thread the tape from the supply reel through the tension arm ①, sensing post ⑫, head assembly ⑬, between the capstan ④ and the pinch roller ⑥, and the automatic shut-off lever ⑦, to the takeup reel (empty reel ⑩).

5. Secure the end of the tape to the empty reel hub.
6. Press the other reel holder ⑦ to secure the takeup reel.

7. Rotate the takeup reel in a counterclockwise direction to remove any slack in the tape.

Be sure to set shut-off lever in the proper operating position.

## LOCATION OF CONTROLS

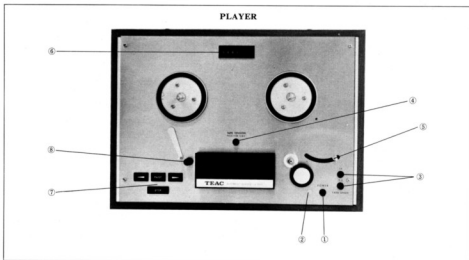

- ① Power switch (POWER)—turns power on or off.
- ② Power pilot lamp—light equipment when is energized.
- ③ Tape speed selector switch (TAPE SPEED)—selects tape speed and appropriate equalizer circuit.  
19 position: 7 1/2 inches per second.  
9.5 position: 3 3/4 inches per second.
- ④ Tape tension selector switch (TAPE TENSION)—provides weaker tape tension when a 1/2 mil a thinner base tape is used.

TAPE BASE	BUTTON POSITION
1 1/2 mil	
1 mil	
1/2 mil	

- ⑤ Automatic shut-off lever—shuts off power to transport when tape runs out.
- ⑥ Index counter—indicate tape position, reset when button is pressed.
- ⑦ Tape transport selector—select tape operation.
  - ▷ : Forward button
  - ◁ : Reverse button
  - FAST: Fast wind button
  - STOP: Stop button
- ⑧ Sensing Post—permits automatic switch-over to reverse playback upon contact with the sensing foil on the tape.

## RECORD AMPLIFIER

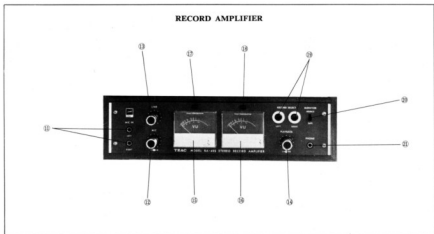

- ⑪ Microphone input jacks (MIC)
- ⑫ Microphone level control (MIC)
- ⑬ Line level control (LINE)
- ⑭ Playback level control (PLAYBACK)

NOTE: Level control shown ⑬, ⑬ and ⑭ above are dual potentiometer. Inner knob (left channel) is friction coupled with outer knob (right channel) to be operated together or separately.

- ⑮ Level indicator meter for left channel.
- ⑯ Level indicator meter for right channel.
- ⑰ Record pilot lamp for left channel.
- ⑱ Record pilot lamp for right channel.
- ⑲ Record selector buttons (RECORD SELECT)
- ⑳ Monitor selector switch (MONITOR)

**SOURCE position:** The input signal to be recorded can be reproduced through headphone or speaker system while the VU meter indicates the level.

**TAPE position:** During playback or while recording, recorded signal on the tape can be reproduced as above.

- ㉑ Headphone jack (PHONE)



## BASIC OPERATIONS OF CONTROLS

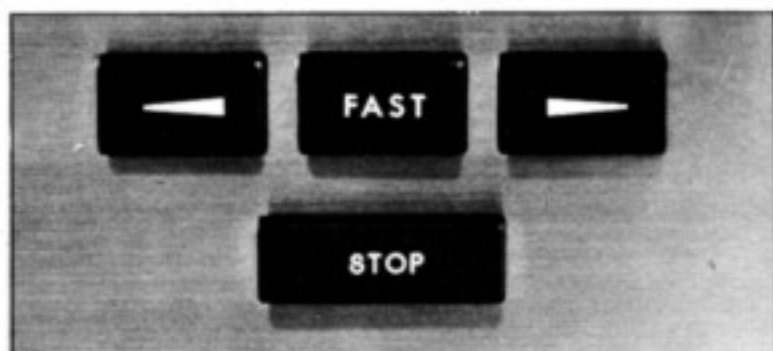

	FORWARD PLAY
	REVERSE PLAY
<b>FAST</b>	FAST WIND, FORWARD (FAST FORWARD)
<b>FAST</b>	FAST WIND, REVERSE (REWIND)
<b>STOP</b>	STOP

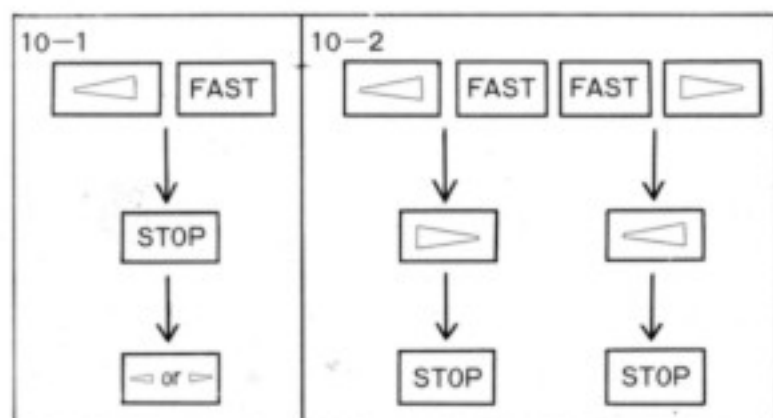
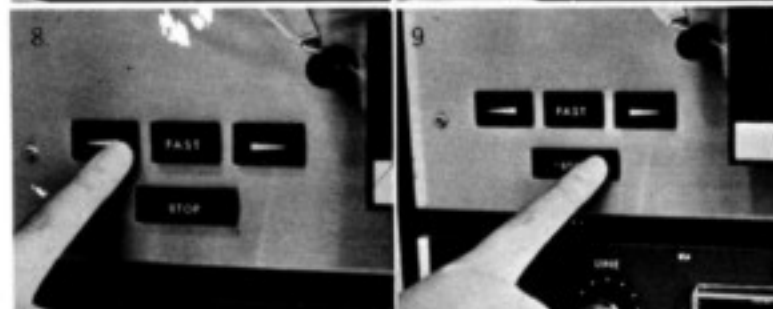
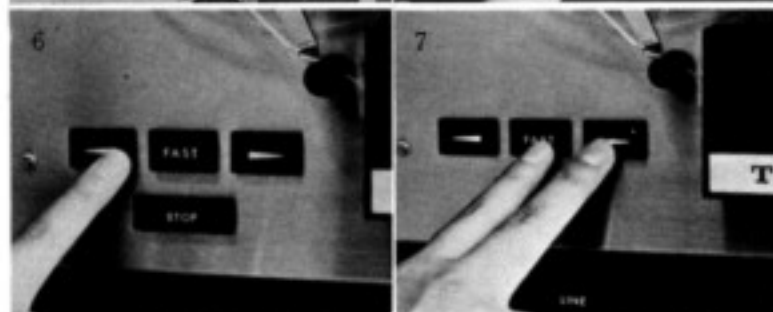

1. Set TAPE SPEED selector to 7<sup>1</sup>/<sub>2</sub> ips (19) or 3<sup>3</sup>/<sub>4</sub> ips (9.5).
2. If the tape to be used is thinner than 1/2 mil press the TAPE TENSION switch.
3. Thread tape on the machine.
4. Press POWER switch button to energize the equipment.
5. Press (forward) button.
6. Press (reverse) button.
7. Press and FAST buttons for fast winding operation.
8. Press button for rewind operation.
9. Press STOP button.
10. Try any combination of above operations.

When changing from fast winding to playback, always be sure to press STOP button, and press or button after complete stop of the tape.

When stopping the tape from fast winding, it is recommended to press the reverse direction button to slow down the tape speed before pressing the stop button. This operation helps to extend the life of both the tape and equipment.

## PLAYING A RECORDED TAPE



Type of recording can be reproduced

**TRACK (s):** Full (Single) track, Two (Half/Double) track monophonic, 4 track monophonic and stereo

**TAPE SPEED:** 7 1/2 ips or 3 3/4 ips

### SETTINGS FOR STEREO AMPLIFIER SYSTEM

Amplifier Controls*	When <b>A-4000S</b> is used	When <b>A-4010S</b> is used
INPUT SELELTOR	AUX	—
MODE SELELTOR	STEREO or MONO**	—
TAPE MONITOR	OFF	ON

\* If your amplifier has different function controls, refer to the operating manual.

\*\* When playing back 4 track monophonic recording, select left channel (or channel A) for tracks 1 and 4 and right channel (or channel B) for tracks 2 and 3.

### SETTINGS FOR THE EQUIPMENT

1. Set **TAPE SPEED** selector switch for the speed desired.
2. Set **TAPE TENSION** selector switch for the tape to be used.
3. Thread the tape.
4. Turn **POWER** on.

### PLAYING A 4 TRACK STEREO RECORDED TAPE

#### **A-4000S** TAPE PLAYER:

1. Press  $\square$  button on the equipment.
2. Adjust volume control, balance, tone control etc., on the amplifier system as needed.

#### **A-4010S** TAPE DECK

1. Set **MONITOR** selector to **TAPE**.
2. Turn **PLAYBACK** control to the counterclockwise limit.
3. Press  $\square$  button.
4. Gradually advance **PLAYBACK** control clockwise until the meter pointers indicate 0 VU at the peaks of the program material.  
To balance the left and right channels levels, adjust one of the friction coupled knobs.
5. Adjust volume, tone controls etc., on the amplifier system.



When the playback of track 1 and 3 is completed, press  $\square$  button to continue playing on track 4 and 2. For automatic reverse operation, refer to page 11 for instruction.

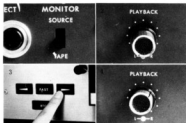

## PLAYING A MONOPHONIC RECORDED TAPE

### A-4000S TAPE PLAYER

1. Press  $\square$  button.
2. Adjust volume, tone etc., on the amplifier system.

### A-4010S TAPE DECK

1. Set MONITOR selector to TAPE.
2. Turn PLAYBACK control to the counterclockwise limit.
3. Press  $\square$  button.
4. Gradually advance PLAYBACK control (inner knob) clockwise until the meter pointer (LEFT) indicates 0 VU at the peak of the program material.
5. Adjust volume, tone controls etc., on the amplifier system.

The standard procedure of playing 4 track monophonic recording with A-4010S tape deck is as follows:

	1st	2nd	3rd	4th
Track used	1	4	3	2
Direction of tape run	$\triangleright$	$\triangleleft$	$\triangleright$	$\triangleleft$
PLAYBACK control knob	inner	inner	outer	outer
Level meter pointer	LEFT	LEFT	RIGHT	RIGHT
Playback output (Loudspeaker)	left	left	right	right

## AUTOMATIC REVERSE PLAY

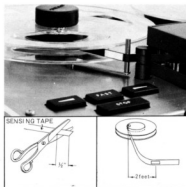

The TEACA-4000S series are an "Automatic player". It is not necessary to turn the reels over to play both side of a tape. At the end of one side, the tape direction will automatically reverse and play in the opposite direction until it is wound back to the beginning.

1. Cut sensing foil approximately 1/2 inches.
2. Put the foil at a position approximately 2 feet from the end, and on shiny side of the tape.

- NOTE:
1. The recommended sensing foil is SCOTCH CONDUCTIVE SENSING TAPE TYPE # 51.
  2. If the sensing foil is too long or too short functional failure may occur.
  3. The sensing foil should precisely be centered on the shiny side of the tape so that the adhesives on the foil is not appeared at the edge of the tape.
  4. If the position of the sensing foil is too close to the end of the tape, the end of the tape may become detached from the hub of the reel before reversing operation takes place.
  5. If the sensing foil or the sensing post is dirty, the proper reversing operation of the tape will not be made.



## MAKING A RECORDING



The length of recording tape is determined by the reel diameter and thickness of the tape.

The recording time indicated in the chart below is for single travel of tape, therefore the total recording time is two or four times of that indicated depending on the method of recording.

The recommended tape for 4 track high fidelity recording is 1 mil or 1 1/2 mil base tape.

Polyester base tape is recommended for use in humid place.

The tape speed can be selected either 7 1/2 ips or 3 3/4 ips. The higher speed provides the best fidelity but excellent fidelity recording can also be made at the low speed (3 3/4 ips) which provides tape economy or longer playing time.

BASE	7 INCH REEL				5 INCH REEL			
	LENGTH	RECORDING TIME		TAPE LENGTH	RECORDING TIME			
		7 1/2 IPS	3 3/4 IPS		7 1/2 IPS	3 3/4 IPS		
1 1/2 MIL	1,200 FEET	80 MIN	60 MIN	600 FEET	15 MIN	30 MIN		
1 MIL	1,800 FEET	45 MIN	90 MIN	900 FEET	23 MIN	45 MIN		
1/2 MIL	2,400 FEET	60 MIN	120 MIN	1,200 FEET	30 MIN	60 MIN		
1/2 MIL	3,600 FEET	90 MIN	180 MIN	1,800 FEET	45 MIN	90 MIN		



**TEAC Microphone** (available at option)

**MC-106:** Dynamic type, Non directional, 10 k ohm

**MD-105:** Dynamic type, Uni directional, 10k/600 ohm

**TEAC Stereo Headphone** (available at option)

**LS-205:** Dynamic type, 10 k ohm

## STEREOPHONIC RECORDING

**Recording from microphones**

Insert microphone plugs to MIC IN jacks. The recording level control is made by MIC control.

**Recording from Line** (phono, tuner, tape etc. ...)

Connect the program source to LINE IN jacks (both L and R). Recording level adjustment is made by LINE level controls.

(See page 5 for interconnection with DIN cord)

**Microphone and Line Mixing**

Connect input sources to MIC IN and LINE IN jacks.

Adjust recording level with respective controls.

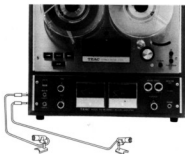

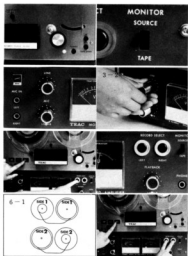

#### Recording procedures

1. Set **TAPE SPEED** and **TAPE TENSION** selectors and thread the tape.
2. Set **MONITOR** selector to **SOURCE**.
3. Adjust **MIC** or **LINE** input level controls (both channels) while watching level indicator meters. The meter pointers should be deflected to the 0 VU position on the loudest portion of the program material. Do not allow the pointer to deflect past the point, as distortion in recording will result.

**NOTE:** If you wish to monitor while recording from the microphone, connect headphones. Turn off power amplifier and speaker (if connected), or reduce volume to zero, otherwise the sound from the speaker will be picked up by the microphone (feedback) and spoil the recording.

4. Press **RECORD SELECT** (both **LEFT** and **RIGHT**) buttons, then press  $\square$  button while holding **RECORD SELECT** buttons.
5. Switch **MONITOR** selector to **TAPE** position for monitoring recorded program while recording.
6. After the recording on tracks 1 and 3 are completed, tracks 4 and 2 can be recorded simply by turning the reels over.

#### MONOPHONIC RECORDING

##### Recording from microphone

Insert microphone plug to **MIC IN - LEFT** jack. The recording level control is made by Left channel (inner knob) **MIC** control.

##### Recording from Line (phono, tuner, tape etc...)

Connect the program source to **LINE IN - L** jack. Recording level adjustment is made by Left channel (inner knob) **LINE** control.

##### Microphone and Line Mixing

Connect input sources to **MIC IN - LEFT** and **LINE IN - L** jacks. Adjust recording level with respective controls.

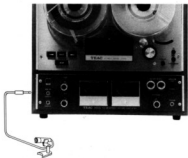

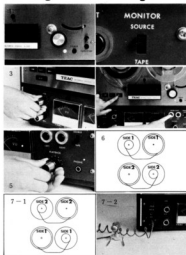

### REMOTE CONTROL



### Recording Procedures

1. Set TAPE SPEED and TAPE TENSION selectors.
2. Set MONITOR selector to SOURCE.
3. Adjust left channel MIC or LINE level control so that indicator meter (LEFT) deflects to 0 VU on the loudest portion of the program.

NOTE: If you wish to monitor while recording from the microphone, care should be taken to avoid feedback as described in "STEREOPHONIC RECORDING".

4. Press RECORD SELECT-LEFT button, then press  button while holding RECORD SELECT button.
5. Switch MONITOR selector to TAPE position for monitoring recorded program while recording.
6. After the recording on track 1 is completed, track 4 can be recorded simply by turning the reels over.
7. Track 3 is recorded next, with the full reel again on the left reel turntable.

But this time RECORD SELECTOR-RIGHT button is depressed and signal inputs are transferred to right channel. The completion of the program may be recorded on track 2 by again turning the reels over.

NOTE: If two microphones are available, they may be plugged into the two inputs so that the input connection need not be transferred when switching between the various tracks.

Following chart will be helpful in making four track monophonic recordings.

Recording	1st	2nd	3rd	4th
Track	1	4	3	2
MIC IN or LINE jack	LEFT	LEFT	RIGHT	RIGHT
Left reel turntable	S*	T	S	T
Right reel turntable	T**	S	T	S
MIC or LINE level control	Inner	Inner	Outer	Outer
RECORD SELECT button	LEFT	LEFT	RIGHT	RIGHT
OUTPUT jack	L	L	R	R
Headphone	Left	Left	Right	Right

\* S: Supply reel    \*\* T: Takeup reel

**TEACA-4000S** series deck/player can be controlled from a distant location by using an optional remote control unit. The unit controls the equipment for start and stop in both directions.

1. Remove dummy plug from REMOTE receptacle.
2. Insert plug of remote control unit into the receptacle.

## SOUND ON SOUND / LANGUAGE TRAINING

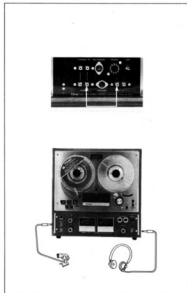
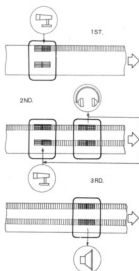

A multiple recording can be made on track 3 (right channel) with input from microphone and reproduced output from previous recording on track 1 (left channel).

This is a particularly useful function for such applications as "Language Training", "Sound-on-Sound" or "Sound-on-Sound-on-Sound" etc.

1. Reset the index counter to zero.
2. Make monophonic recording on track 1 with basic material such as music, instructor's speech etc.
3. While recording, slide monitor switch to tape and adjust playback level control so that the meter pointer indicates 0 VU at fix of the material being recorded.
4. Rewind tape to the starting position of the recording.
5. Connect OUTPUT - L and LINE IN - R with cord.
6. Insert plug of the headphone in to the PHONE jack, and the microphone plug into MIC IN - RIGHT jack.
7. Start tape for monophonic recording on track 3.
8. While monitoring the playback sound by headphone (Left), make mix recording on track 3 by adjusting MIC and LINE level controls.
9. When the recording is completed, rewind the tape and playback through right channel (track 3).

If the results are not satisfactory, second or third "TAKE" may be made, since the original recording has been preserved on track 1.

Recording	1st	2nd	3rd
MIC IN or LINE IN jack	L	R	L
MIC or LINE level control	L	R	L
MONITOR selector	SOURCE or TAPE	TAPE	TAPE
Level indicator meter	LEFT	RIGHT	LEFT
RECORD SELECT button	LEFT	RIGHT	LEFT
PLAYBACK level control	L	L	R
Headphone	Left	Left	Right

## ERASING



TEAC E-2 BULK ERASER

The arrangement of heads when viewed from front is shown.

The erase head is energized during recording operation to automatically erase the program previously recorded, and the new program is recorded by the following record head.

To erase a tape without recording a new program, simply turn MIC and LINE level control knobs to counterclockwise limit and operate the equipment for recording.

In the event that it is desired to completely erase the tape prior to recording (to insure quiet margins, leaders, unused tracks). **TEAC Model E-2 Bulk Eraser** may be used.

### Partial Erasing

1. Locate the portion desired to be erased.
2. Mark the starting position of the portion at the gap of the forward playback head, using a grease pencil, water-base sign pen etc.
3. Mark the ending position of the portion in similar procedure.
4. Rewind and locate the tape so that the starting position is slightly before the gap of the erase head.
5. Start the equipment for recording and stop the tape when the ending mark is reached to the gap of the erase head.

**CARE MUST BE TAKEN NOT TO ERASE THE PORTION WANTED TO BE PRESERVED**

When intermittent recordings are made unerasable spots may be remained on the tape at the places where recordings were started. It is recommended to separately erase the tape prior to such recording.

## MAKING SPLICES

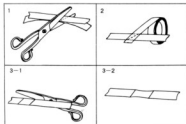

1. Overlap the two ends of the tape and cut them at approximately 60 degree angle. Align both ends with the shiny side up.
2. Cover the aligned ends with splicing tape and press firmly.
3. Trim excess of the splicing tape, cutting into the recording tape slightly.

**NOTE:** 1. Demagnetize scissors with bulk eraser or head demagnetizer before using for splicing.  
2. Do not use conventional adhesive tape for splicing.



## MAINTENANCE

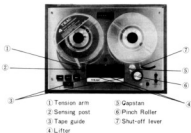

TEAC I-1 HEAD DEMAGNETIZER

## CLEANING

To prevent the loss of high frequency response or insufficient erasure, the heads should be cleaned frequently under average operating conditions, cleaning the heads after each eight to ten hours of use will insure against the loss of high frequency response. To clean the head, moisten a clean, lint cloth with alcohol. Carefully wipe the face of each head and the following components to remove all traces of dirt and magnetic oxide deposits.

**NOTE:** Do not use silicon polishing cloth to clean capstan shaft, pinch roller and reel turntable shafts.

## DEMAGNETIZATION

The tape heads should be demagnetized at least once in every 50 hours of operation to maintain the best possible performance of the equipment and to prevent the possibility of gradual deterioration of your prerecorded tapes.

1. Turn the equipment off.
2. Attach protective covering on tip of **TEAC** model **I-1** head demagnetizer.
3. Energize demagnetizer.
4. Place the tip of the demagnetizer against upper pole pieces of head, slowly move the tip downward toward lower pole pieces of the head. Alternate between the two set of the pole pieces while slowly withdrawing the demagnetizer.
5. Repeat this process each of heads.
6. Remove the power from the demagnetizer when it is at least one foot away from the equipment.

**NOTE:** Do not allow the demagnetizer to come in close proximity with the level indicator meter, as permanent damage to the meter may result.

## LUBRICATION

The following parts should be lubricated after operation of approximately 1000 hours, or at least once a year with **TEAC #29228** oil (Mobil DTE Heavy Mideum).

Capstan Shaft.....2 drops

Remove the dust cap by turning counterclockwise and wet oil chamber.

Pinch Roller Shaft.....1 drop

Pull off the pinch roller and lubricate the shaft.

Motors (three).....approximately 1cc for each bearing, or 0.5cc when the equipment is not frequently used.

**NOTE:** 1. Wipe off any excess of oil from rubber parts and drive belt with cloth dampen with alcohol.

2. Lubricate the equipment immediately after operation while it is warm.

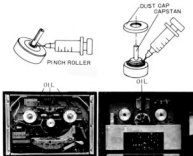

## VOLTAGE AND FREQUENCY CONVERSION

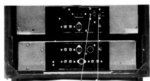

AC power voltage Selector

AC power frequency Selector

220V 115V 110V 100V	80% 50%	100VOLT 50CYCLE
220V 115V 110V 100V	80% 50%	100VOLT 60CYCLE
220V 115V 110V 100V	80% 50%	110VOLT 50CYCLE
220V 115V 110V 100V	80% 50%	110VOLT 60CYCLE
220V 115V 110V 100V	80% 50%	115VOLT 60CYCLE
220V 115V 110V 100V	80% 50%	220VOLT 50CYCLE

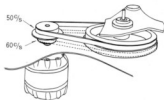

## REMOVING THE FRONT PANEL

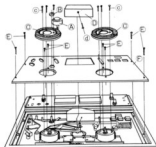

The equipment is normally adjusted to operate on a electric power source to the voltage and frequency specified on the carton box.

If it should be necessary to convert the **A-4000S** series deck /player to operate from a power source of different voltage or frequency, it may be easily accomplished as follows:

### VOLTAGE CONVERSION

This equipment permits selection of the power supply of 100V, 117V or 220V. For changing the voltage of power supply, use a screwdriver to set the voltage selector switch, located on the rear of the player.

### FREQUENCY CONVERSION

The conversion may be made in the following sequence.

1. Set frequency selector switch on the rear of the player to the required frequency.
2. Remove front stainless steel panel (refer to "REMOVING THE FRONT PANEL.")
3. Move the drive belt on the pulley and flywheel. In this equipment, the motor pulley and the flywheel each have two steps, permitting frequency change by simply moving the drive belt from one step to other. The belt moving process should begin from the flywheel when converting from 60 to 50 cycles operation, or from the pulley when converting from 50 to 60 cycles operation. Following completion of the process, turn the flywheel manually to ensure that the belt has been attached properly. The smaller diameter portion of the motor pulley is for 60 cycle operation.

Removal of the panel is required for motor lubrication, frequency conversion, repairs etc.

1. Remove power cord and other connecting cords.
2. Place the player in horizontal position.
3. Remove the following parts.
  - Ⓐ Pinch roller (Pull off)
  - Ⓑ Capstan dust cap (Turn counterclockwise direction)
  - Ⓒ Reel Turntable (Remove three screws from each turntable)
  - Ⓓ Head Cover (Remove one screw at the top)
  - Ⓔ Remove the four mounting screws at the corner of the stainless steel panel and the two mounting screws under the reel turntable.
  - Ⓕ Panel

**NOTE:** When reinstall the panel care should be taken to allow free movement of the shut-off lever.

## CUSTOM MOUNTING

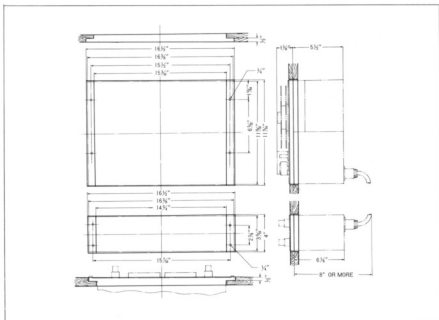

## REMOVING THE EQUIPMENT FROM CASE

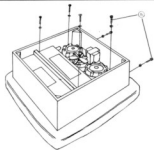

### Player:

1. Remove power cord and other connecting cords.
2. Lay the recorder face down on a soft mat.
3. Remove rear panel and 8 screws.
4. Remove four screws (Ⓟ).
5. Lift the case from the player.

### Amplifier:

1. Remove four screws on front panel.
2. Pull out the amplifier from case.

## SPECIFICATIONS

Heads	Four, 4 track 2 channel Erase, Record, Forward playback and Reverse playback
Reel Size	7" maximum
Tape Speed	7 $\frac{1}{2}$ and 3 $\frac{3}{4}$ ips ( $\pm 0.5\%$ )
Motors	1- dual speed hysteresis motor for capstan drive 2- eddy current type outer rotor motors for reel turntables
Wow and Flutter	7 $\frac{1}{2}$ ips 0.12% 3 $\frac{3}{4}$ ips 0.15%
Fast Winding Time	Approximately 90 seconds for 1,200 feet
Frequency Response	7 $\frac{1}{2}$ ips 30 to 20,000 Hz ( $\pm 3$ db 50 to 15,000 Hz) 3 $\frac{3}{4}$ ips 40 to 12,000 Hz ( $\pm 3$ db 50 to 7,500 Hz)
Equalization	50 microseconds (NAB) for 7 $\frac{1}{2}$ ips 120 microseconds (EIA) for 3 $\frac{3}{4}$ ips
Signal to Noise Ratio	50 db
Crosstalk	50 db channel to channel at 1,000 Hz 40 db between adjacent tracks at 100 Hz
Input	Microphone: 10,000 ohms, 0.25 mV minimum Line: 100,000 ohms, 0.14V minimum
Output	1 volt for a load impedance 10,000 ohms or more
Power Requirements	100, 117, 220 V AC 50 or 60 Hz, 110 VA
Dimensions and Weight	17 $\frac{1}{8}$ " $\times$ 17 $\frac{1}{16}$ " $\times$ 8 $\frac{1}{2}$ " 44 lbs

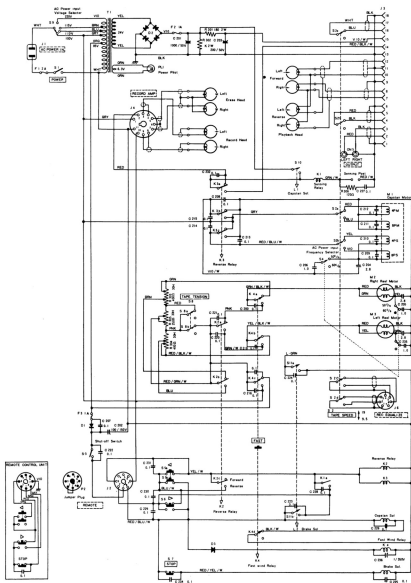

**A-4000S TAPE PLAYER, TAPE TRANSPORT MECHANISM SCHEMATIC DIAGRAM**

NOTE: COMPONENT VALUES ARE SUBJECT TO CHANGE WITHOUT NOTICE.

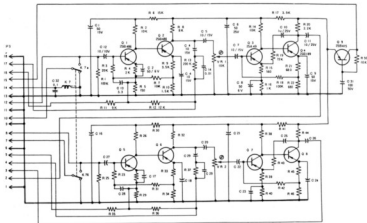

**A-4000S TAPE PLAYER, PLAYBACK AMPLIFIER SCHEMATIC DIAGRAM**

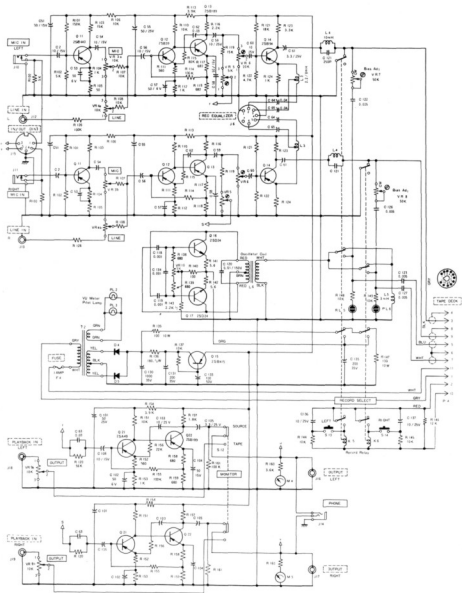

RA-405 RECORDING AMPLIFIER SCHEMATIC DIAGRAM

NOTE: COMPONENT VALUES ARE SUBJECT TO CHANGE WITHOUT NOTICE