

TEAC[®]

A-4010S

STEREO TAPE DECK

SERVICE MANUAL

CHASSIS SERIAL NUMBERS BEGINNING 14459

TEAC CORPORATION

TABLE OF CONTENTS

SPECIFICATIONS	1
Controls and Switches	2
Connections —rear—	4
REMOVING THE EQUIPMENT FROM CASE	6
1. Pinch Roller Pressure Adjustment	7
2. Supply and Takeup Motor Torque Adjustment	8
3. Half-mil Tension Adjustment	8
4. Brake Adjustment	10
5. Reel Height Adjustment	12
6. Head Replacement	13
7. Belt Replacement	14
8. Capstan Assembly Replacement	14
RECORD AND PLAYBACK AMPLIFIER BLOCK DIAGRAM	16
ELECTRICAL CHECKS AND ADJUSTMENTS	17
1. PLAYBACK PERFORMANCE	18
Playback Head Azimuth Alignment	
Frequency Response Check	
Playback Level Calibration	
Playback Amplifier Check	
2. RECORD PERFORMANCE.....	21
Record Bias Adjustments	
Record Amplifier Bias Trap	
Record Level Calibration	
Record Head Azimuth Alignment	
Frequency Response Checks	
Record Noise Check	
Record Amplifier Check	
PREVENTIVE MAINTENANCE	25
Cleaning the Heads	
Demagnetization	
Lubrication	
TROUBLESHOOTING CHARTS	26
SIMPLIFIED CIRCUITS	28
LEVEL AND DC VOLTAGE CHARTS.....	32
SCHEMATIC DIAGRAM A-4000S	36
SCHEMATIC DIAGRAM RA-40S.....	38
A-4010 AND A-4010S COMPARISON CHART	39
EXPLODED VIEW	

SPECIFICATIONS

Reel Size	7" maximum 5" minimum
Tape Speed	7½ and 3¾ ips ($\pm 0.5\%$)
Heads	Four, 4 track 2 channel: Erase, record, forward play and reverse play
Motors	One 2 speed hysteresis synchronous for capstan drive Two eddy current type outer-rotor for reel drive
Fast Winding Time	Approximately 90 seconds for 1,200 feet
Wow and Flutter	7½ ips—0.12%, 3¾ ips—0.15%
Frequency Response	7½ ips—30 to 20,000 Hz ($\pm 3\text{dB}$ 50 to 15,000 Hz) 3¾ ips—40 to 15,000 Hz ($\pm 3\text{dB}$ 50 to 10,000 Hz)
Equalization	50 microseconds (NAB) for 7½ ips 120 microseconds (EIA) for 3¾ ips
Signal to Noise Ratio	50dB
Crosstalk	50dB channel to channel at 1,000 Hz 40dB between adjacent tracks at 100 Hz
Input	Microphone—10,000 ohms, 0.25 mV minimum Line—10,000 ohms, 0.14 V minimum
Output	1 volt for a load impedance of 100,000 ohms or more Headphones—high impedance
Power Requirements	100, 117, 220 VAC, 50 or 60 Hz, 110 W nominal
Dimensions	17¾" \times 17¼" \times 8½"
Weight	44 lbs.

CONTROLS AND SWITCHES CONNECTIONS

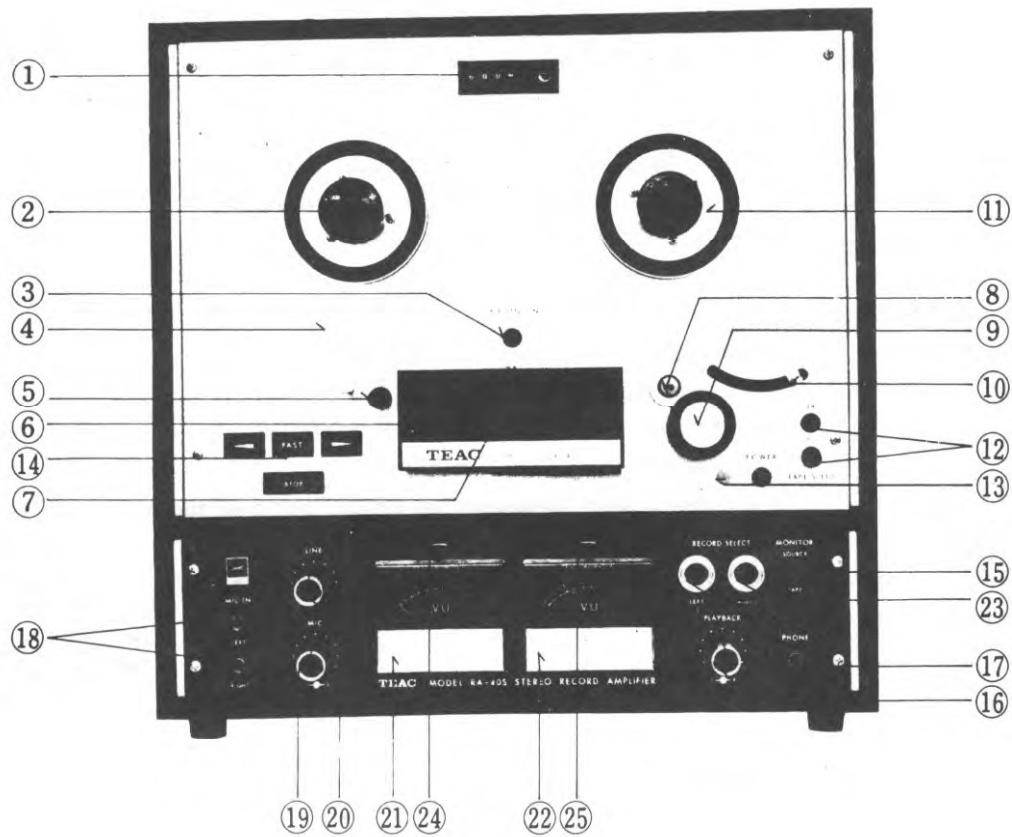

- ① INDEX COUNTER: indicate tape position
- ② LEFT TURNTABLE
- ③ TAPE TENSION: provides weaker tape tension when a 1/2 mil a thinner base tape is used
- ④ TENSION ARM
- ⑤ SENSING POST: permits automatic switch-over to reverse playback upon contact with the sensing foil on the tape
- ⑥ TAPE LIFTER: lifts tape from heads during fast wind operations
- ⑦ HEAD ASSEMBLY: 4 heads
- ⑧ CAPSTAN: drives tape for recording and playback
- ⑨ PINCH ROLLER: engages tape to capstan during recording and playback
- ⑩ AUTOMATIC SHUT-OFF LEVER: shuts off power to transport
- ⑪ RIGHT TURNTABLE
- ⑫ TAPE SPEED: selects tape speed and appropriate equalizer circuit
- ⑬ POWER: turns power on or off—Power pilot lamp— light equipment when is energized
- ⑭ TAPE TRANSPORT SELECTOR—select tape operation
 - ▷ : Forward button for forward play mode
 - ◁ : Reverse button for reverse play mode
 - FAST: Fast wind button for fast winding operation
 - STOP: Stop button

When changing from fast winding to playback, always be sure to press STOP button, and press ▷ or ◁ button after complete stop of the tape
- ⑮ MONITOR
 - SOURCE position: The input signal to be recorded can be reproduced through headphone or speaker system while the VU meter indicates the level
 - TAPE position: During playback or while recording, recorded signal on the tape can be reproduced as above.
- ⑯ PLAYBACK: Turn PLAYBACK control to the counterclockwise limit.
- ⑰ PHONES: High impedance (10kΩ or more) Headphone jack
- ⑱ MIC IN: High impedance (10kΩ or more) Microphone input jacks
- ⑲ MIC: Microphone level control
- ⑳ LINE: Line level control
- ㉑ LEVEL INDICATOR METER: for left channel (with 6VAC Lamp)
- ㉒ LEVEL INDICATOR METER: for right channel (with 6VAC Lamp)
- ㉓ RECORD SELECT: Press RECORD SELECT (both LEFT and RIGHT) buttons, then press ▷ button while holding RECORD SELECT buttons
- ㉔ RECORD PILOT LAMP: for left channel (used neon Lamp)
- ㉕ RECORD PILOT LAMP: for right channel (used neon Lamp)

CONNECTIONS

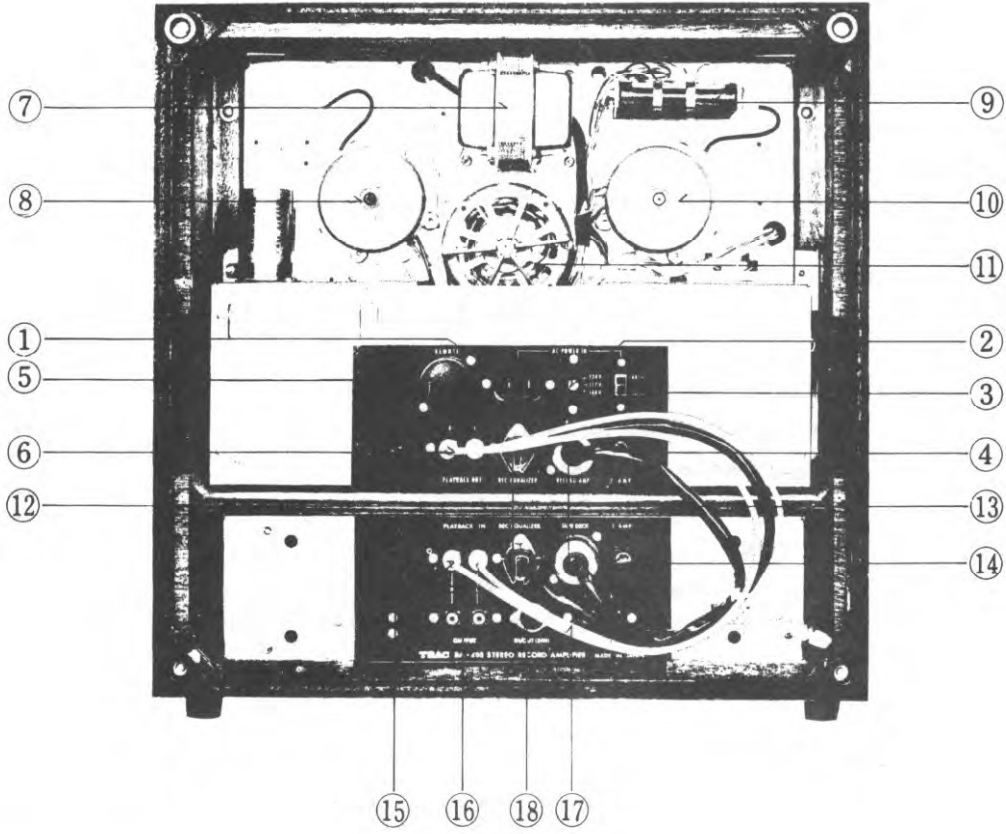

- ① AC POWER IN: Receptacle, AC power
- ② SELECTOR: for AC power voltage
- ③ SELECTOR: for AC power frequency
- ④ FUSE 2-AMP: Fuse, 2 amperes
- ⑤ REMOTE: Receptacle, Remote control unit
- ⑥ PLAYBACK OUT: Playback output Jacks (will deliver +4dB from TEST TAPE at reference level)
- ⑦ POWER TRANSFORMER
- ⑧ RIGHT REEL MOTOR: 6 poles
- ⑨ RESISTORS: For tape tension adjusting resistors
- ⑩ LIFT REEL MOTOR: 6 poles
- ⑪ CAPSTAN MOTOR: ¼ poles
- ⑫ REC EQUALIZER: Record equalizer cord
- ⑬ TAPE DECK: Tape player cord
- ⑭ FUSE 1-AMP: Fuse, 1 ampere
- ⑮ PLAYBACK IN: Playback monitor input Jack
- ⑯ OUTPUT: Output Jack
- ⑰ LINE IN: Line input Jack
- ⑱ IN/OUT (DIN): The mixing operation of microphone and line input signal will not be made when the DIN cords used

INTERCONNECTIONS

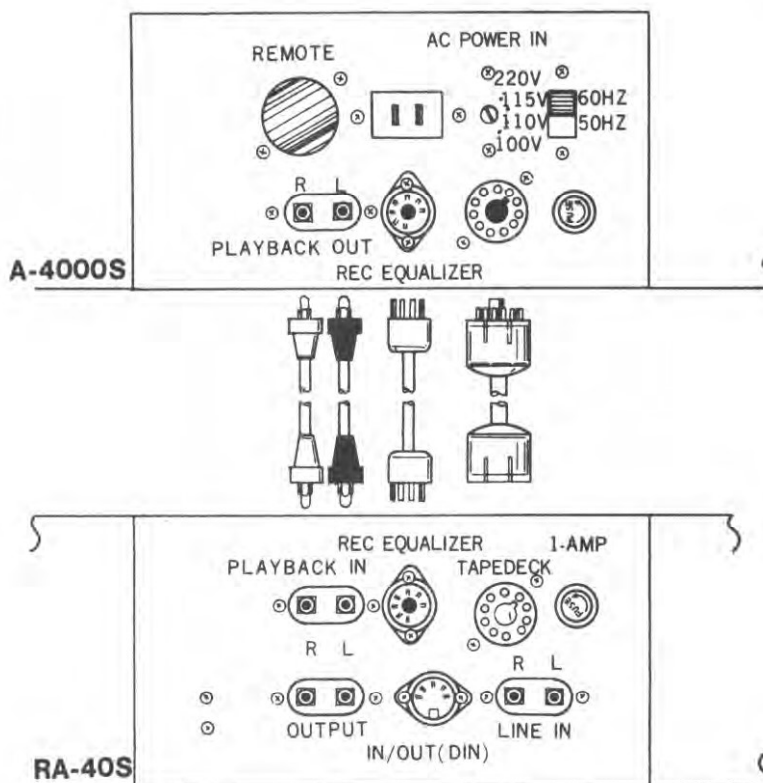

REMOVING THE EQUIPMENT FROM CASE

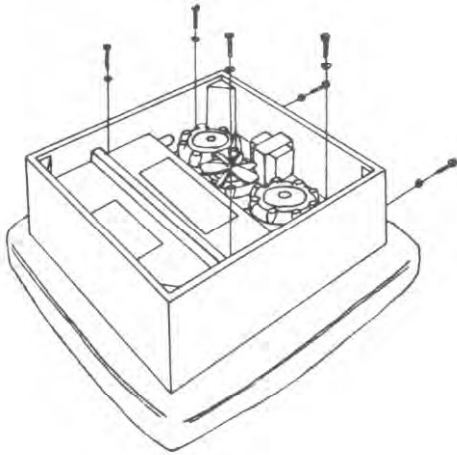

PLAYER :

Remove power cord and other connecting cords.

Lay the recorder face down on a soft mat.

Remove rear panel and 8 screws.

Remove four screws.

Lift the case from the player.

AMPLIFIER :

Place the case in a vertical position.

Remove four screws on front panel.

Pull out the amplifier from case.

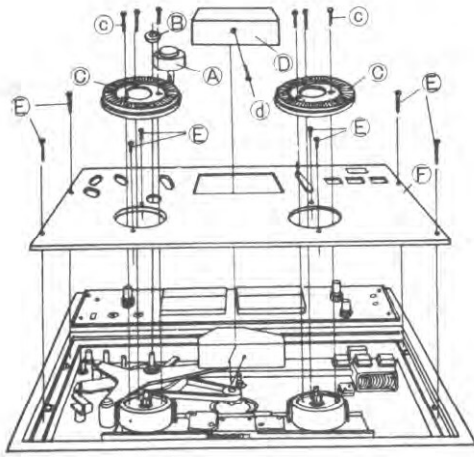

FRONT PANEL :

Place the player in a horizontal position.

Remove the following parts.

- Ⓐ Pinch roller (Pull off)
- Ⓑ Capstan dust cap (Unscrew in counterclockwise direction)
- Ⓒ Reel Turntable (Remove three screws from each turntable)
- Ⓓ Head Cover (Remove one screw at the top)
- Ⓔ Remove the four mounting screws at the corner of the stainless steel panel and two mounting screws under the reel turntables.
- Ⓕ Panel

NOTE: When reinstalling the panel care should be taken to allow free movement of the auto shutoff lever.

- Ⓖ Screw does not have to be removed.

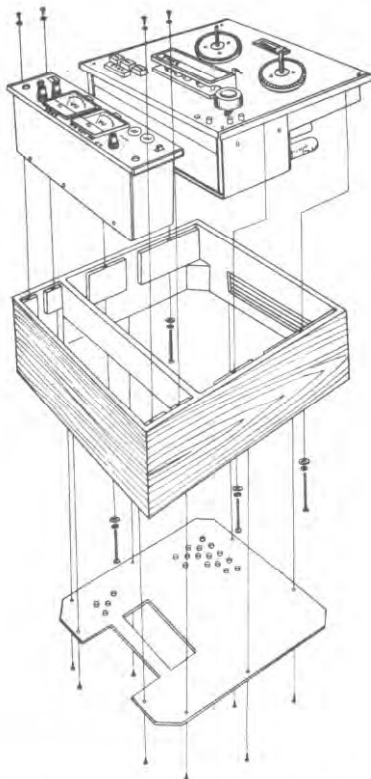

FIG.2 REMOVING THE EQUIPMENT FROM CASE

MECHANICAL CHECKS AND ADJUSTMENTS

PINCH ROLLER PRESSURE:

The pinch roller is forced against the capstan by the pinch roller solenoid. Pinch roller pressure is supplied by the pressure spring on the solenoid shaft. The pressure against the capstan should be 4 to 5 lbs.

PROCEDURE FOR CHECK & ADJUSTMENT:

1. Tape or hold the automatic shut-off arm in the on position.
2. Make a strong twine loop about 10" in diameter.
3. Place this loop behind the pinch roller and around the pinch roller shaft, attach a 0-8 lb. spring scale to the other side of the loop.
4. Place the deck in the play mode.
5. Holding the scale at right angles to the head assembly, slowly draw the scale away from the pinch roller. Read the scale at the instant the pinch roller leaves the capstan.
6. If adjustment is necessary, adjust the takeup nut (Figure 3) on the capstan solenoid shaft.

NOTE: Reduced pinch roller pressure can result from either two extremes of adjustment. Maximum efficiency is obtained from the solenoid only when its plunger is "exactly bottomed." Only small compensating adjustments should be made or required.

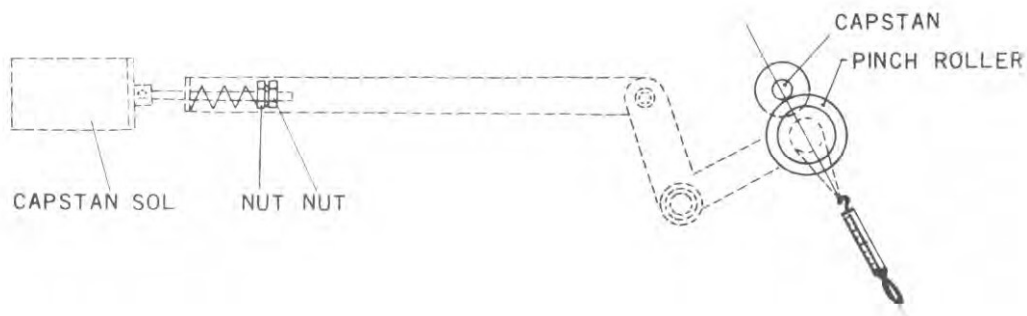

FIG. 3 PINCH ROLLER PRESSURE ADJUSTMENT

SUPPLY AND TAKEUP MOTOR TORQUE:

Supply and takeup motor torques should be within the limits listed in the chart below.

Mode	Left Reel	Right Reel
Forward Play	1.96 to 2.24 oz	1.96 to 2.24 oz
Reverse Play	1.96 to 2.24 oz	1.96 to 2.24 oz

565-64 Grams

PROCEDURE FOR ADJUSTMENT:

Refer to Figure 4 and 5.

1. Tape or block the auto-shutoff arm in the on position and set the TAPE TENSION switch in the normal position.
2. Place an empty 7 inch reel with a 4 inch diameter hub on the left turntable.
3. Make small loops at both ends of a 30" length of string.
4. Attach one loop to the tape anchor on the tape reel and the other end to a 0-8 oz. spring scale.
5. Depress the ◀ button and allow the clockwise rotation of the reel to draw the string around the hub.
6. Making certain that the string is not rubbing the reel flanges, allow the scale to move in towards the hub, holding back with just enough tension to allow a steady reading on the scale.
7. If necessary, adjust resistor R-304 slider A (Fig. 4) until a scale reading of 1.96 to 2.24 oz. is obtained.
8. After all the string has been wound on the reel depress the ▶ button.
9. As soon as motor pull is felt slowly draw the scale away from the hub, against the motor torque, until a constant reading is obtained. If necessary, adjust resistor R-304 slider B (Fig. 4) until a scale reading of 1.96 to 2.24 oz. is obtained.
10. Place the tape reel on the right turntable. Depress the ◀ button and check torque using the same procedure as outlined in Step 6. If necessary, adjust resistor R-303 slider B (Fig. 4) until a scale reading of 1.96 to 2.24 oz. is obtained.
11. After all the string has been wound on the reel depress the ▶ button.
12. As soon as motor pull is felt slowly pull the scale away from the hub, against the motor torque, until a constant reading is obtained. If necessary adjust resistor R-303 slider A (Fig. 4) until a scale reading of 1.96 to 2.24 oz. is obtained.

HALF-MIL TENSION ADJUSTMENT:

13. Set the tape tension selector switch to the 1/2 MIL position. Repeat Steps 8. and 11. of the "Supply and Takeup Motor Torque" section. The scale reading should decrease by approximately 0.3 ounces adjust R-305.

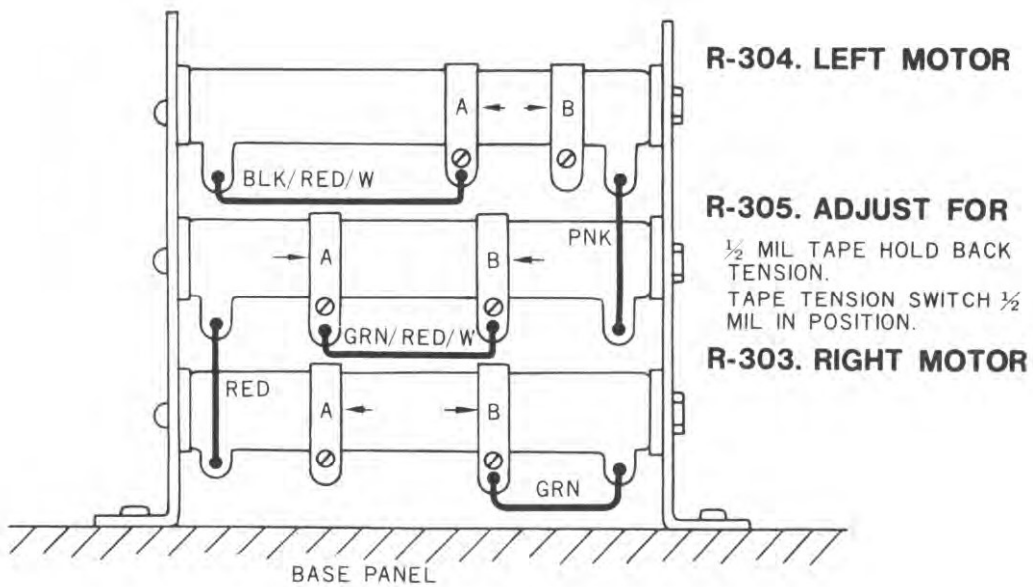

NOTE: ← DECREASE TAPE TENSION DIRECTION

FIG. 4 TAPE TENSIONING RESISTORS

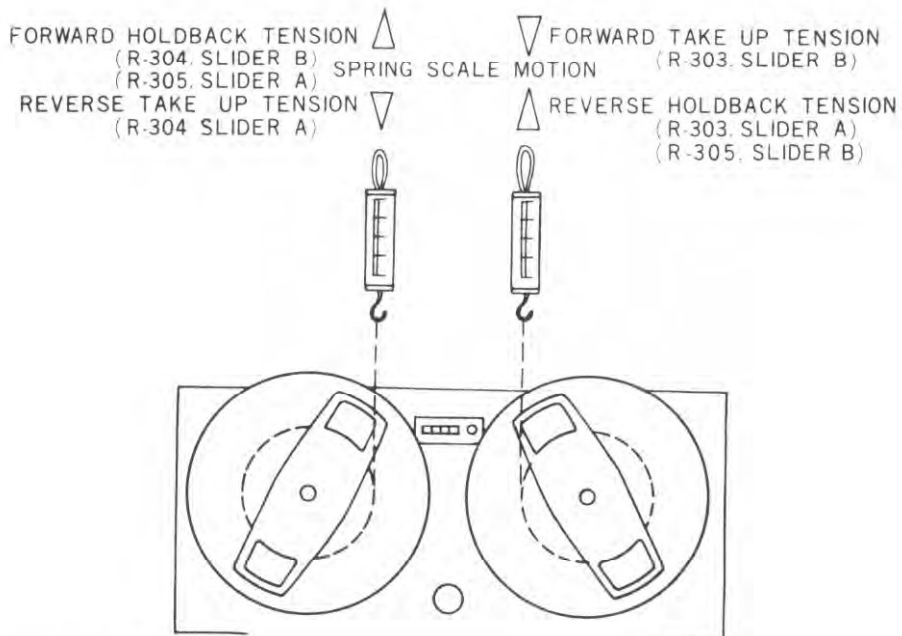

FIG. 5 SUPPLY AND TAKE-UP TENSION ADJUSTMENTS

BRAKE ADJUSTMENT:

Refer to Figure 6.

Brake adjustments are made with no power connected to the equipment

1. Place an empty 7' reel with a 4" diameter hub on the left reel turntable.
2. Make a small loop at both ends of a 30" length of string.
3. Attach one loop to the anchor on the reel hub and the other to a 0 to 10 oz. spring scale.
4. Wind several turns of string around the counterclockwise.
5. Pull the scale away from the reel, making certain the string does not rub the reel flanges. Take a reading only when the turntable is in steady motion, because the force required to overcome the static friction will produce a false and excessively high initial reading. The scale reading should be approximately 5.5 to 7 oz.
6. If adjustment is required, remove the deck front panel as shown in Figure 6.
7. Remove the two screws on the micro switch board located between the reel motors, making sure to reference the position of the microswitches with the brake band screws. Remove the board.
8. Adjust the left motor brake by positioning the brake adjusting spring arm (Figure 6) for the proper brake tension.
9. To check and adjust the right reel brake repeat all steps as described for left reel with the exception that all directions of rotation are clockwise. Adjust spring arm (Figure 6) for proper brake tension.
10. When replacing the microswitch board, depress the brake solenoid plunger then release it while observing the microswitches. The switches should not be touching the brake band screw when relaxed, yet should depress fully when the brake solenoid plunger is pushed in.

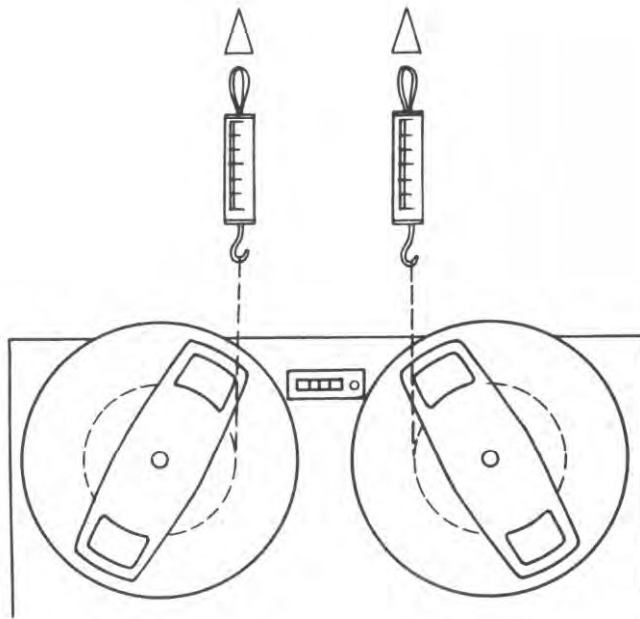

△ ; **SPRING SCALE MOTION**

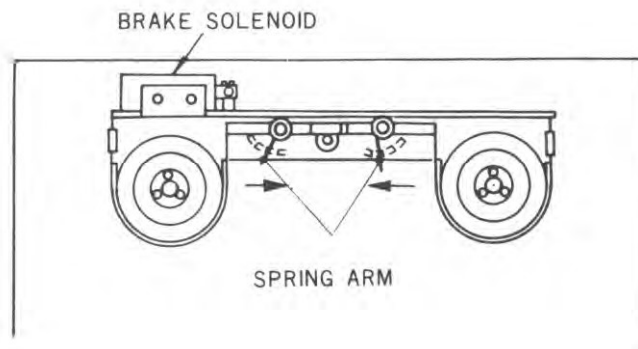

NOTE: ← DECREASE BRAKE TENSION DIRECTION.

FIG.6 BRAKE ADJUSTMENTS

REEL HEIGHT ADJUSTMENT:

Due to manufacturing differences in plastic tape reels or in cases of slightly warped reels it might be necessary to move the tape reel outward to prevent the tape from rubbing the reel flange. Reel adjustment paper shims are provided with the recorder and can be placed on the outside of the reel turntable to compensate for occasional difference in reel thickness. If it is found that all reels rub, adjustment in the height of the turntable must be made.

1. Remove the 3 screws on the reel turntable and pull the turntable off the reel spindle.
2. Metal or paper shims are used for factory adjustment and if these shims are installed they can be used as a pattern to cut proper shims. If they are not installed, trace the shim pattern below.

CAUTION: Do not exceed 1/16" total shim thickness.

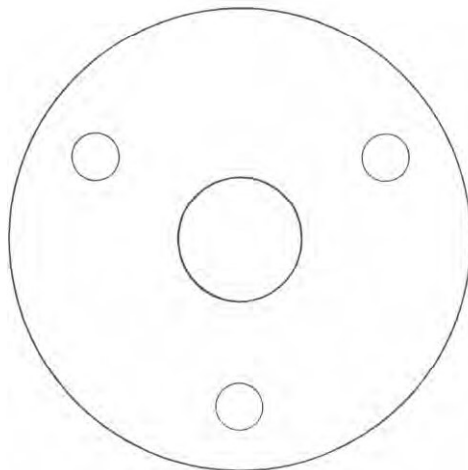

FULL SCALE SHIM DIAGRAM

HEAD REPLACEMENT AND ALIGNMENT:

1. Remove the head cover by removing the screw on top of it.
2. Locate the wires from the defective head and note the points to which they are soldered. Refer to Figure 7.
3. Using a low heat iron, unsolder the 4 wires of the defective head from the terminal board.
4. Remove the 2 nuts securing the head to the plate. Remove the head.
5. Route the new head wires to the terminal board and install the new head to the mounting plate. Solder the wires to the board.
6. Thread a length of tape with the oxide removed across the heads and observe the position of the head poles. The erase head pole should be above the edge of the tape by about the thickness of a pencil line. The record head pole should be even with the top of the tape. The forward head pole should be even with the bottom of the tape.
7. Head height is adjusted at the factory to very critical tolerances. Normally head replacement would not disturb the height adjustment. If highly critical adjustment is required, refer to Figure 7. Adjustment is made with the 3 screws holding the head plate to the top plate.
8. After height adjustment make sure that all head surfaces are parallel with the tape guide surfaces when viewed from the side.
9. Perform azimuth alignment as described in the "Electrical Checks and Adjustments" section.

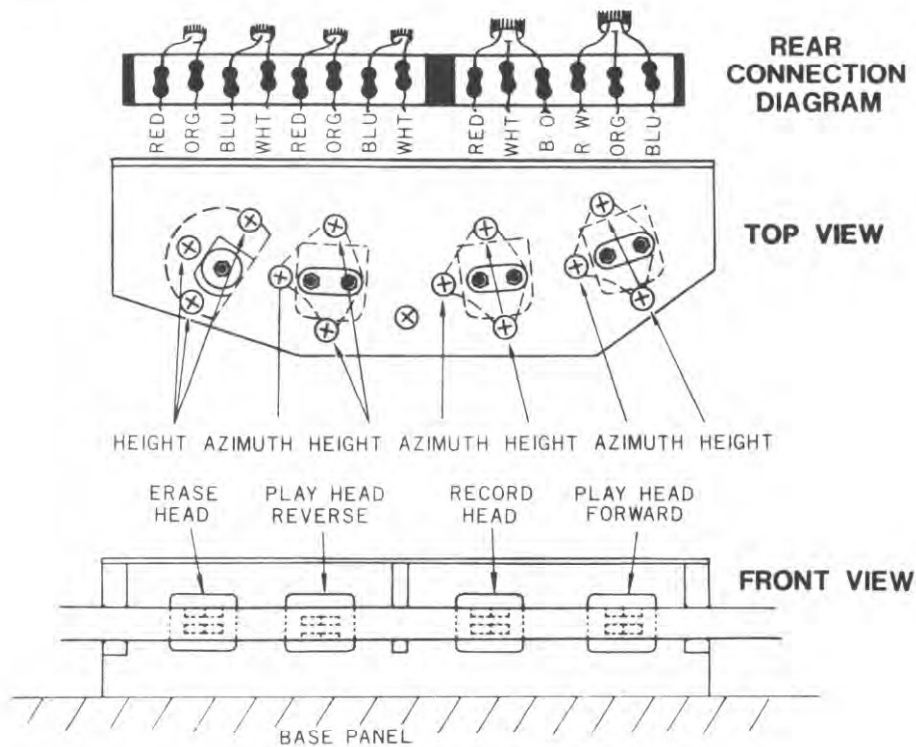

FIG. 7 HEAD ASSEMBLY

BELT REPLACEMENT

1. Remove the stainless steel panel (see page 6)
2. Remove 2 screws on black auto-shutoff arm backing plate.
3. Remove rear plate.
4. Remove 4 screws holding capstan assembly casting. The screws are removed from the rear.
5. Gently fold casting assembly forward until enough clearance is obtained to remove and replace belt.

CAPSTAN REPLACEMENT

6. Remove 3 screws holding flywheel to casting.
7. Separate flywheel from casting.
CAUTION: Do not force or bend any part. The assembly should come out with gentle movement.
8. Loosen the set-screws on the rear of flywheel and pull out capstan assembly.
9. Replace the capstan assembly and tighten the set-screws.
10. Reinstall the flywheel and tighten the 3 screws.
11. Replace the belt and replace the casting. Tighten the 4 screws.
12. Replace the auto-shutoff arm backing plate.
13. Replace the front cover.

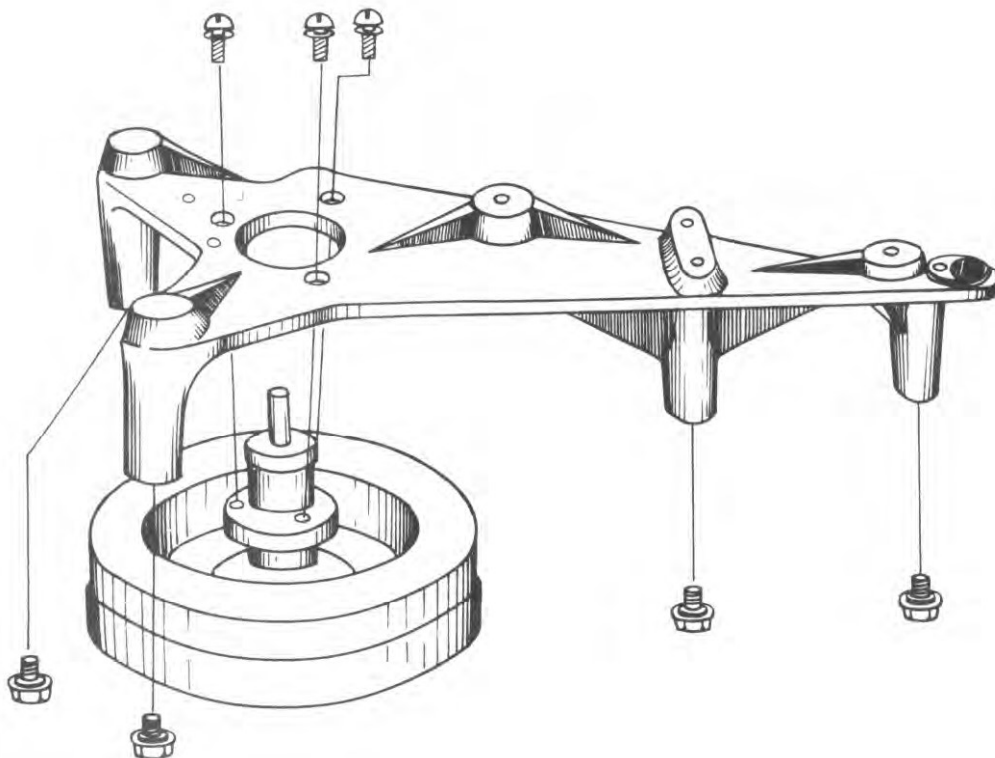

FIG. 8 CAPSTAN ASSEMBLY

MEMORANDA

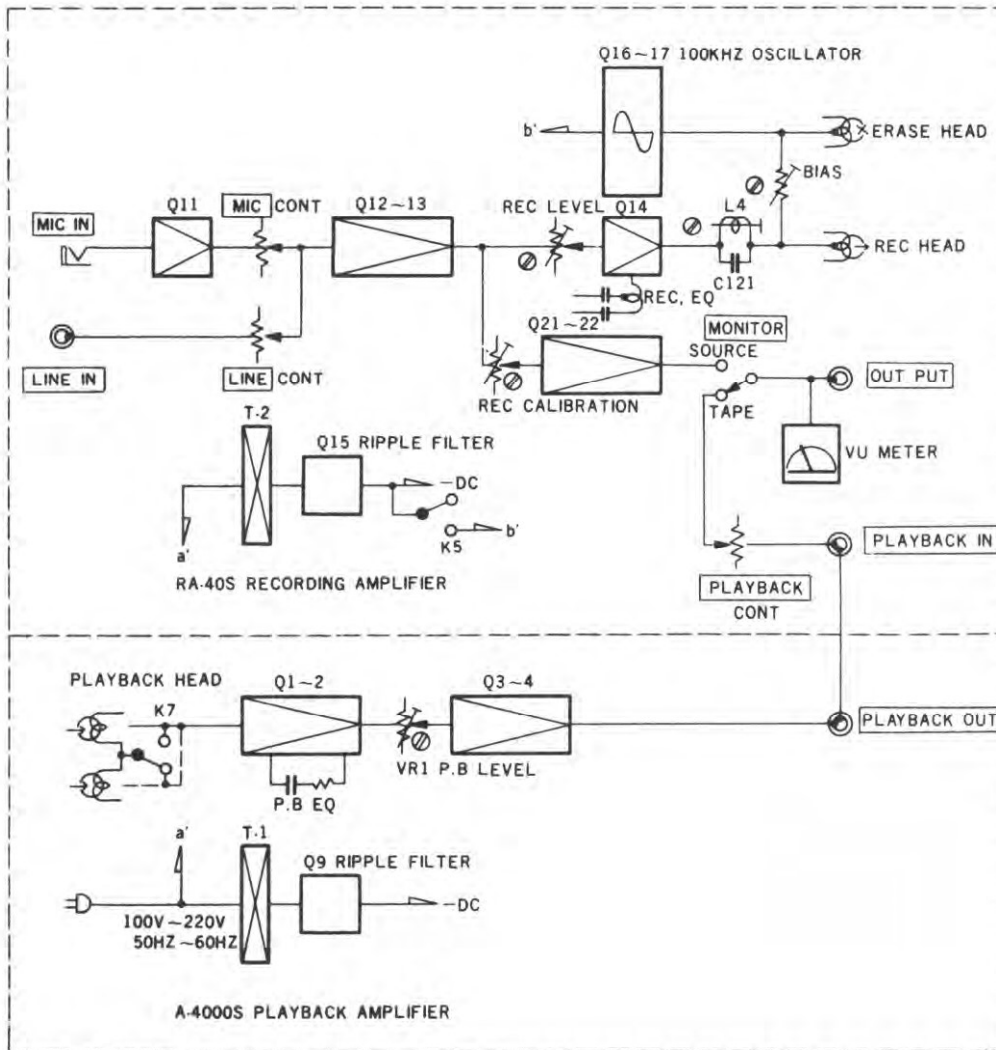

FIG. 9 A-4010S AMPLIFIERS BLOCK DIAGRAM (ONLY LEFT CHANNEL)

ELECTRICAL CHECKS AND ADJUSTMENTS

EQUIPMENT REQUIRED:

1. Test Tape For 7½ ips: TEAC 62801, AMPEX 31321-01, 31321-04 or equivalent.
For 3¾ ips: TEAC 62801, AMPEX 31321-01 or 31321-04 can be used, except for signals below 250 cps.
2. AC VTVM —60dB (1 mV) Sensitivity.
3. Audio Oscillator 50 to 15,000 Hz.
4. Amplifier and speaker or headsets for monitoring.
5. 1 mil. 1,800 foot recording tape.
6. Channel Selecting Switch.
7. External bias trap.

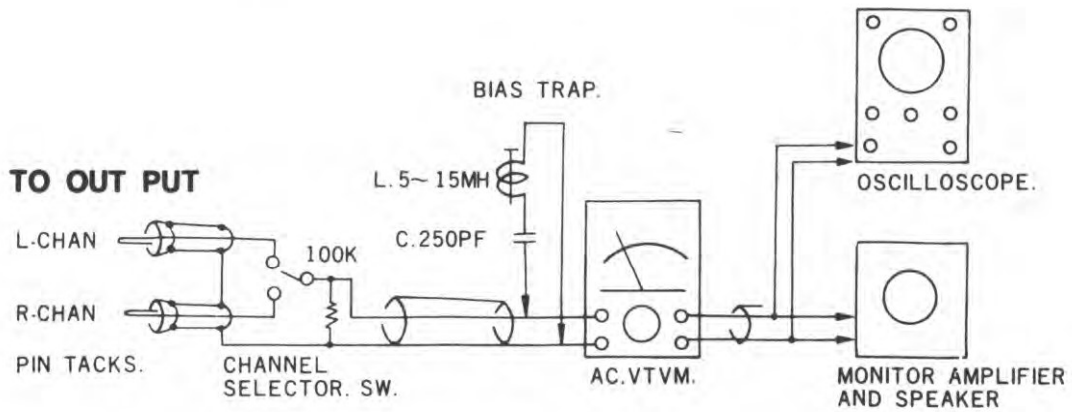

FIG. 10 TEST EQUIPMENT HOOK UP

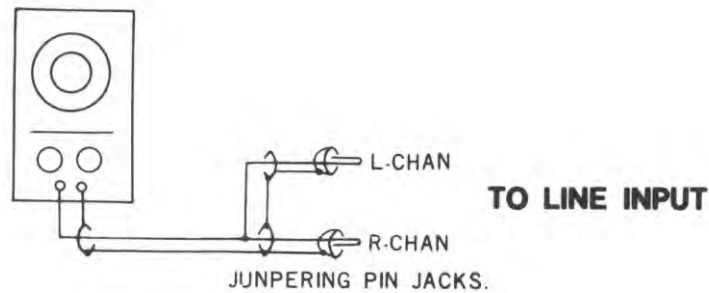

FIG. 11 AUDIO OSCILLATOR AND CONNECTION CABLE

PLAYBACK PERFORMANCE

CAUTION: Clean and demagnetize heads before proceeding. (see page 27)

1. Thread a playback test tape on the recorder.
2. Connect test equipment as illustrated in Figure 10.
3. Set the TAPE SPEED to 7 $\frac{1}{2}$ ips and the MONITOR switch to TAPE set the PLAYBACK level control to maximum position.
4. Play a 500 or 700 Hz reference tone (recorded 10 db below normal level) the VTVM should read approx. -6 db.

PLAYBACK HEAD AZIMUTH ALIGNMENT:

5. Play a 12 or 15 KHz tone and turn azimuth adjustment screw (Figure 7) of the forward playback head until a maximum peak is obtained on the VTVM.
6. Depress the \triangleleft button and turn azimuth adjustment screw (Figure 7) of the reverse playback head for maximum peak on the VTVM.

FREQUENCY RESPONSE CHECK:

7. Play the test tape tones from 12 or 15 KHz down to 50 Hz, observing the output response on the VTVM. Make this check with both channels in forward and reverse play modes at both speeds.
8. Since the playback circuit uses highly stable low impedance heads no equalization adjustments are necessary.

PLAYBACK LEVEL CALIBRATION:

9. Disconnect the A-4000S output cables from the OUTPUT jacks. Connect the VTVM to the A-4000S output.
10. Play a 700 Hz tone recorded at 7 $\frac{1}{2}$ ips and normal operating level.
11. Adjust the playback level controls on the printed circuit board, VR-1 left channel and VR-2 right (Figure 13) channel, to obtain a +4dB reading on the VTVM.
12. Connect the VTVM to the RA-40S output and reconnect the A-4000S to the RA-40S.

PLAYBACK AMPLIFIER CHECK (A-4000S):

If a complete playback amplifier check is desired, connect an Audio Oscillator to the playback input circuit as shown in Figure 15. Then check the frequency response, noise amplifier gain, etc. Figure 14 shows a typical frequency response curve. This is a high gain circuit and excessive input may cause overloading and distortion in the amplifier. Adjust the output level of the Audio Oscillator so the VU meter indication is kept below 0 VU. Make certain that the Audio Oscillator and input cables are free from hum and noise, which may cause false readings.

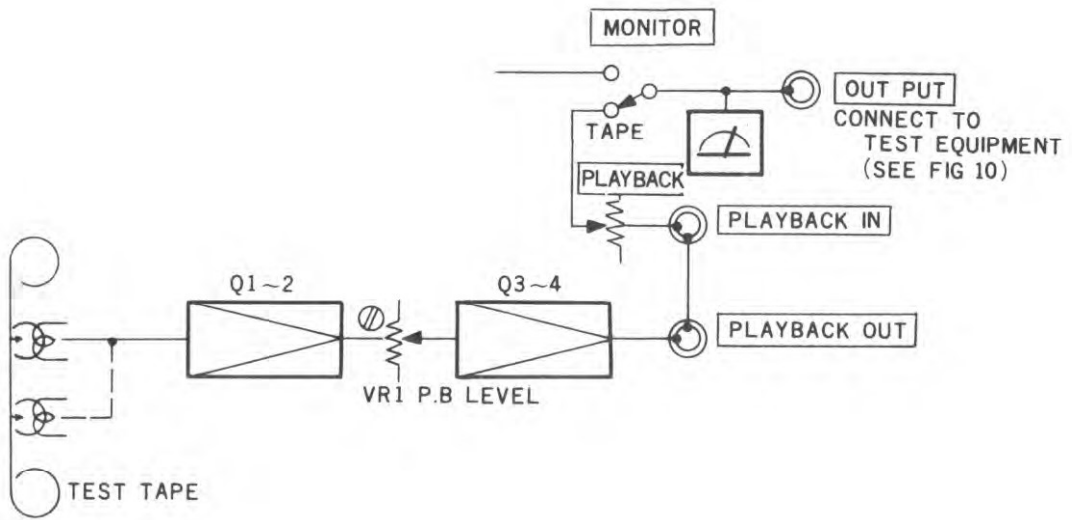

FIG.12 CIRCUIT FOR PLAYBACK PERFORMANCE SECTION

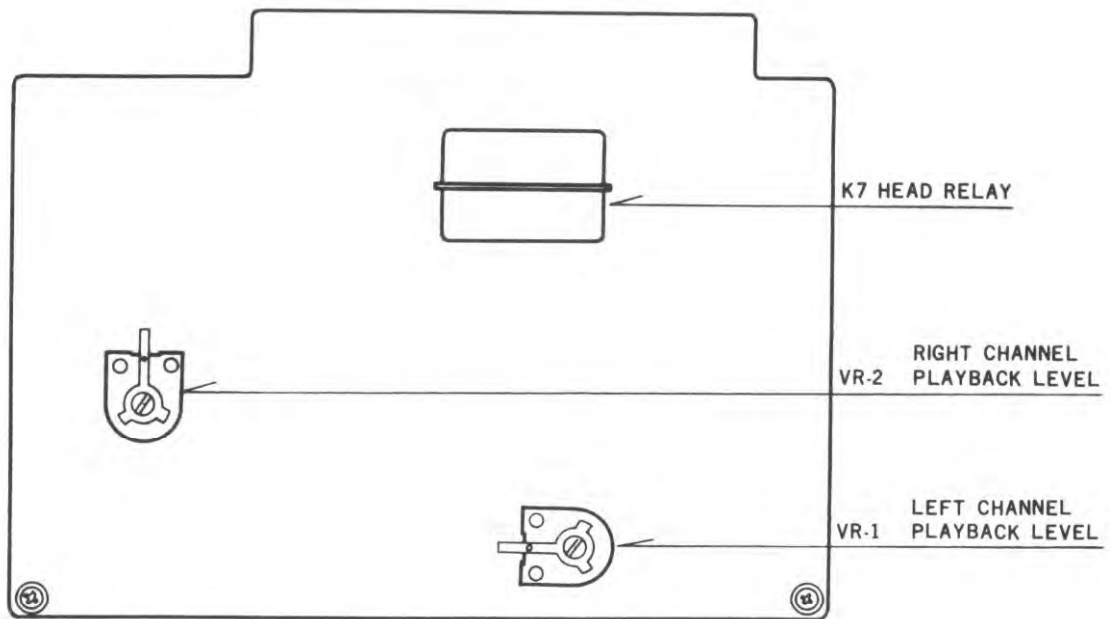

FIG.13 A-4000S PLAYBACK AMPLIFIER PRINTED BOARD ADJUSTABLE PARTS LOCATION (TOP VIEW)

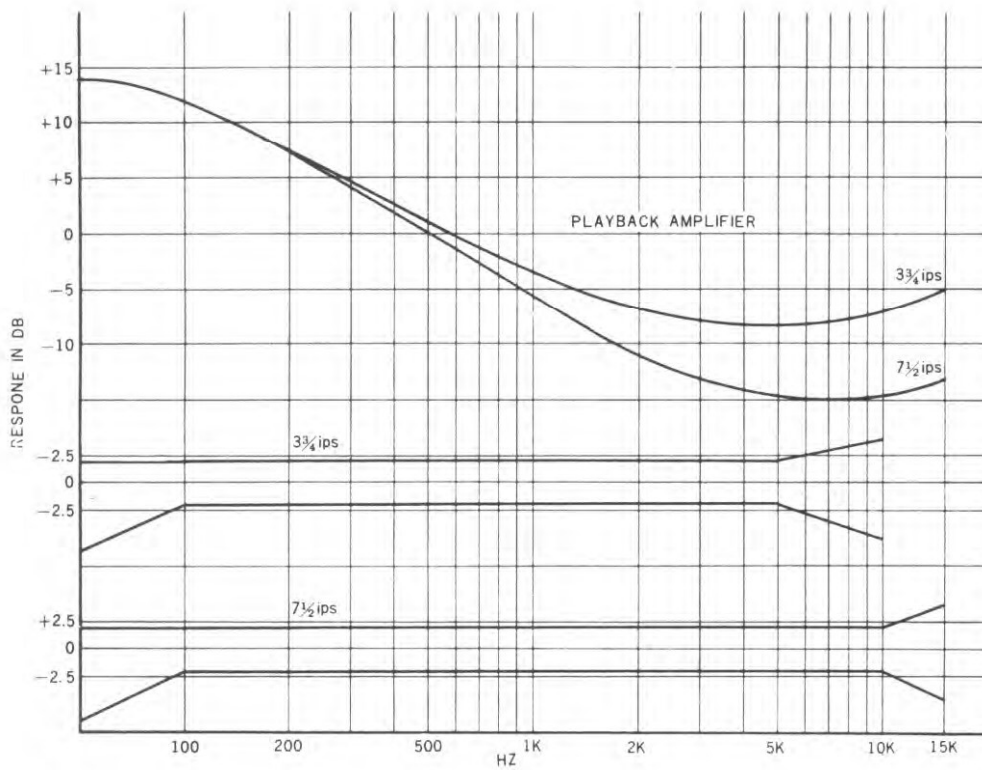
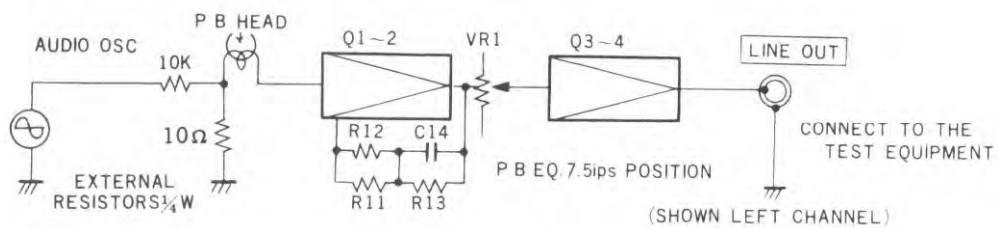

FIG.14 TYPICAL RESPONSE CURVE AND FREQUENCY RESPONSE LIMITS



NOTE : SET THE AUDIO OSCILLATOR TO 500 HZ AND
ADJUST OSCILLATOR OUT PUT CONTROL FOR
A VTVM READING OF 0 dB.

FIG.15 CIRCUIT FOR CHECKING PLAYBACK AMPLIFIER

RECORDING PERFORMANCE

RECORD BIAS ADJUSTMENTS:

1. Connect an Audio Oscillator to the LEFT channel LINE input. Set the MONITOR switch to the TAPE position. Set the tape speed to $7\frac{1}{2}$ ips.
2. While recording a 500 Hz tone on a blank tape, adjust VR-7 (Figure 17) for maximum peak on the VTVM, then turn the potentiometer clockwise until the reading decreases by 0.5dB from the maximum level.
3. Connect the Audio Oscillator to the RIGHT channel LINE input and repeat Step 2, adjusting VR-8 (Figure 17).

RECORD AMPLIFIER BIAS TRAP: (WITH EXTERNAL BIAS TRAP)

1. Using a blank tape, place the recorder in the record mode with no signal input.
2. While holding a VTVM probe at the junction of C-61L and L-4L (Figure 17) adjust L-4L for minimum reading on the VTVM.
3. Repeat the procedure for the right channel by connecting the VTVM to the junction of L-4R and C-61R (Figure 17). Adjust L-4R for minimum reading on the VTVM.

NOTE: These tank circuits prevent the bias signal from entering the record amplifier and under normal no signal conditions no voltage should be present at the above points.

RECORD HEAD AZIMUTH ALIGNMENT: (WITH EXTERNAL BIAS TRAP)

1. Connect an Audio Oscillator to the LEFT and RIGHT LINE INPUTS. Connect a channel selecting switch bias trap and VTVM to the OUTPUT jacks. Set tape speed to $7\frac{1}{2}$ ips and MONITOR switch to TAPE.
2. While recording a 15 KHz signal on the tape, set the LINE input control so the VTVM reads -15 to -20 dB below normal operating level. Adjust the record head azimuth screw (Figure 7) for maximum output.
3. Check the adjustment by using the above procedure for the right channel. The peaks should be of the same level.

RECORD LEVEL CALIBRATION:

NOTE: The playback level must be calibrated prior to record level calibration. See "Playback Level Calibration" section.

1. Set the MONITOR switch to TAPE. Set tape speed to $7\frac{1}{2}$ ips.
2. Turn the PLAYBACK level controls to maximum.
3. Adjust the Audio Oscillator output to -16 dB (0.12 volts) at 500 Hz.
4. Set the LINE control to maximum.
5. While recording a 500 Hz signal on the tape, adjust VR-6L (Figure 17) to obtain VU meter reading of 0 VU on the left channel adjust VR-6R to obtain VU meter reading of 0 VU on the right channel.
6. Set MONITOR switch to SOURCE.
7. Adjust record meter level calibration VR-5L and VR-5R to obtain VU meter reading of 0 VU.

FREQUENCY RESPONSE CHECKS: (WITH EXTERNAL BIAS TRAP)

To avoid tape saturation, frequency response checks should be made at least -20 dB below operating level.

1. Connect an Audio Oscillator to the LEFT channel input. Set tape speed to $7\frac{1}{2}$ ips and MONITOR switch to TAPE.

2. While recording a 500 Hz signal on the tape, set LINE INPUT level control to obtain a VU meter reading of 0 VU. then Adjust PLAYBACK level control for a VTVM reading of 0 db (0.775 V).
3. Reset LINE INPUT level control to obtain a VTVM reading of -20 db.
4. Record signals from 50 Hz to 15 KHz at 7 $\frac{1}{2}$ ips, or from 50 Hz to 7.5 KHz at 3 $\frac{3}{4}$ ips. Read the output on the VTVM. If adjustment is required, adjust the value of R-115L (Figure 17) for the low end and C-65L for the high end at 7 $\frac{1}{2}$ ips. Adjust C-64-L for high end response at 3 $\frac{3}{4}$ ips. For left channel. Adjust R-115R C-65R and C-64-R for right channel. These are fixed components and have to be replaced with other values. An increase in resistance lowers the low end response. An increase in capacitance increases the high end response.

RECORD NOISE CHECK:

1. While recording a 1 KHz signal adjust the LINE level control to obtain a VU meter reading of 0 VU and read the output on the VTVM (+4dB.)
2. Set the LINE and MIC level controls to minimum.
3. Rewind the tape to the start of the 500 Hz recording.
4. Place the recorder in the RECORD mode once more and read the noise level while recording over the previously recorded 1 KHz signal.
5. While monitoring the record mode with no signal input, adjust VR-10 for minimum noise and dropouts.
6. Check the signal to noise ratio for both channels at both speeds. The noise level should be -50dB or less. This represents the signal to noise ratio for 3% total harmonic distortion (peak recording level).

RECORD AMPLIFIER CHECK:

If a more complete check of the record amplifier is required, connect a VTVM to the record circuit as shown in Figure 19. Check the frequency response, noise, amplifier gain, etc. To avoid overloading the amplifier the frequency response check should be made at least 15 to 20dB below normal operating level.

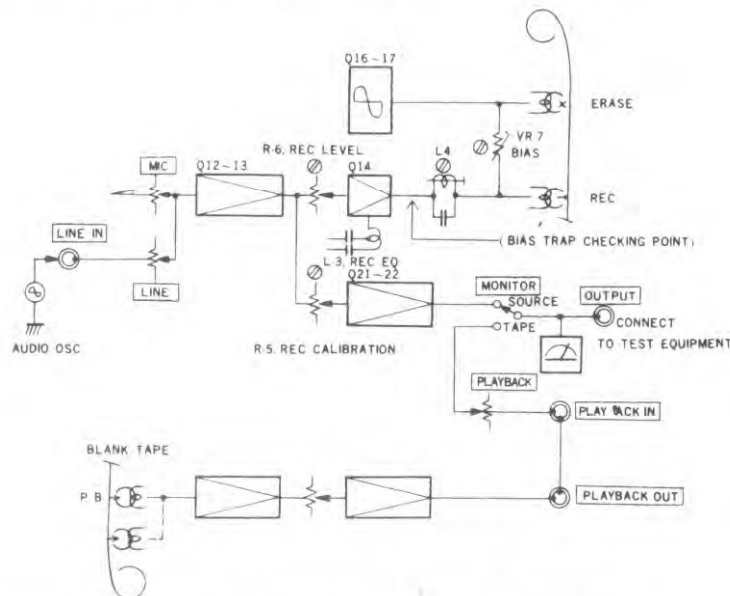

FIG. 16 CIRCUITS FOR ALIGNING RECORD SECTION

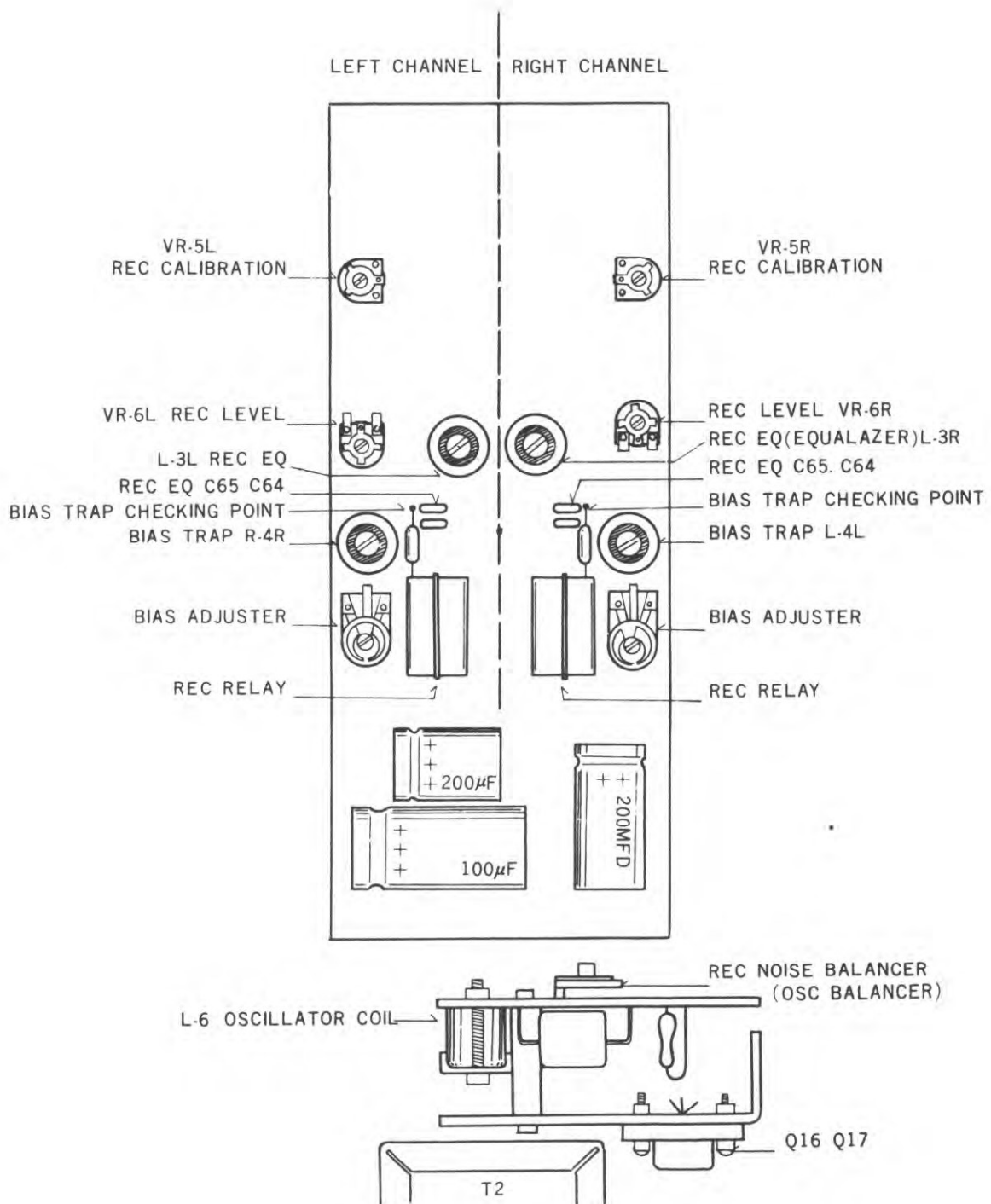

FIG. 17 ADJUSTABLE PARTS LOCATION (TOP VIEW)

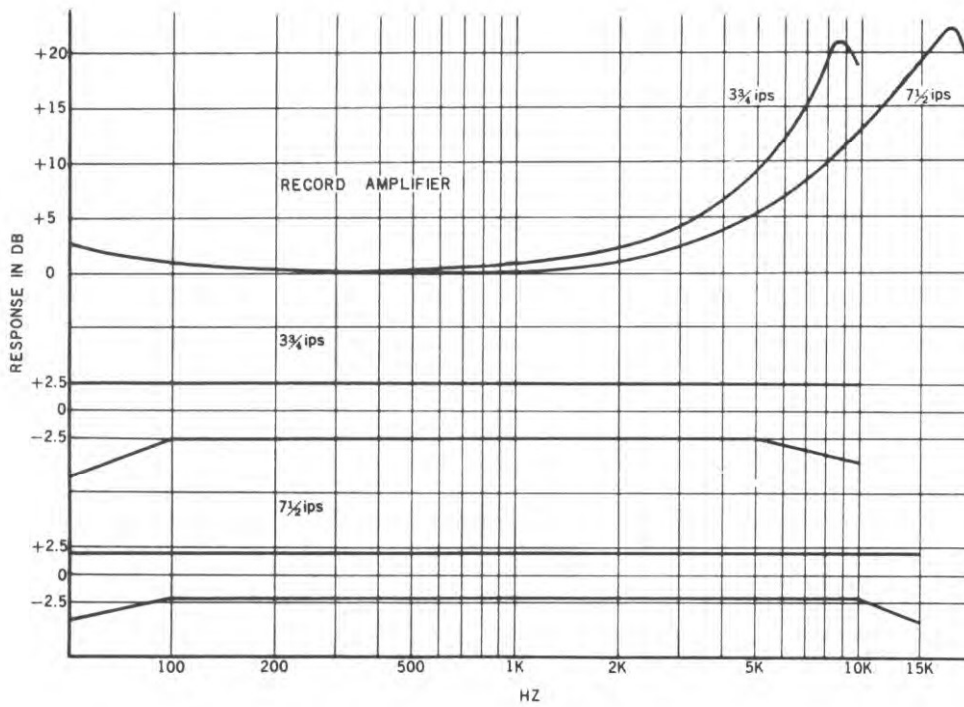
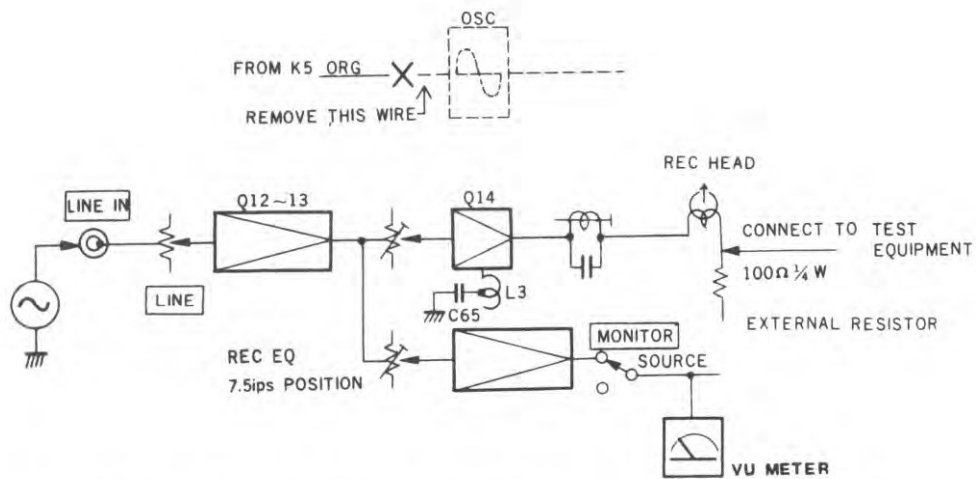

FIG.18 TYPICAL RESPONSE CURVE AND OVER ALL FREQUENCY RESPONSE LIMITS



NOTE : **LINE** CONTROL FOR **VU** METER INDICATION OF -15~20dB

FIG.19 CIRCUIT FOR CHECKING RECORDAMPLIFIER

PREVENTIVE MAINTENANCE

EQUIPMENT REQUIRED

Cleaner	Model TZ-251.	Demagnetizer	Model E-1
For Heads	#251A.	Oil and Polisher	Model TZ-252
For Pinch Roller	#251B.		#29228

CLEANING :

To prevent the loss of high frequency response or insufficient erasure, the heads should be cleaned frequently. Under average operating conditions, cleaning the heads after each eight to ten hours of use will insure against the loss of high frequency response. To clean the heads, moisten a clean lintless cloth with carbon tetrachloride or alcohol. Carefully wipe the face of each head and the tape guides to remove all traces of dirt and magnetic oxide deposits.

DEMAGNETIZATION :

The tape heads should be demagnetized occasionally with a head demagnetizer to maintain the best possible performance of the equipment and to prevent the possibility of gradual deterioration of your recorded tapes.

To demagnetize the heads, use a two-pole type demagnetizer with a piece of tape over the tips. With the power completely removed from the recorder, gently place the protected tips against the upper pole pieces of the first head. Then slowly move the tips downward toward the lower pole pieces of the head. Alternate between the two sets of pole pieces while slowly withdrawing the demagnetizer. Repeat this process for each of the heads. Do not remove the power from the demagnetizer until it is at least 2 feet away from the recorder.

LUBRICATION :

The following parts of the tape transport mechanism require lubrication after every thousand hours of operation, or yearly. Use a high grade of SAE-10 nondetergent oil or other high grade motor lubricant.

Capstan assembly upper bearing	
(Remove dust cap)	2 drops
Pinch roller bearing.....	1 drop
Motors	2 drops (after every 1,000 hours of operation or 1 drop yearly)

CAUTION: DO NOT OVERLUBRICATE. If oil spills on the pinch roller or belt, clean it immediately with ethyl alcohol.

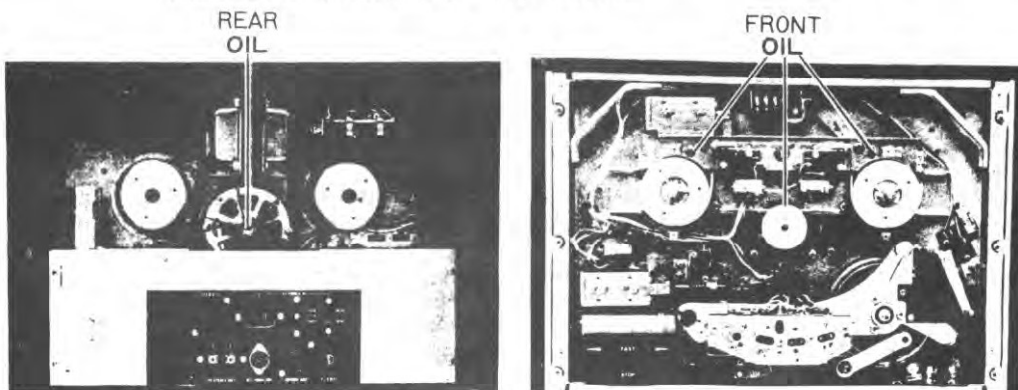
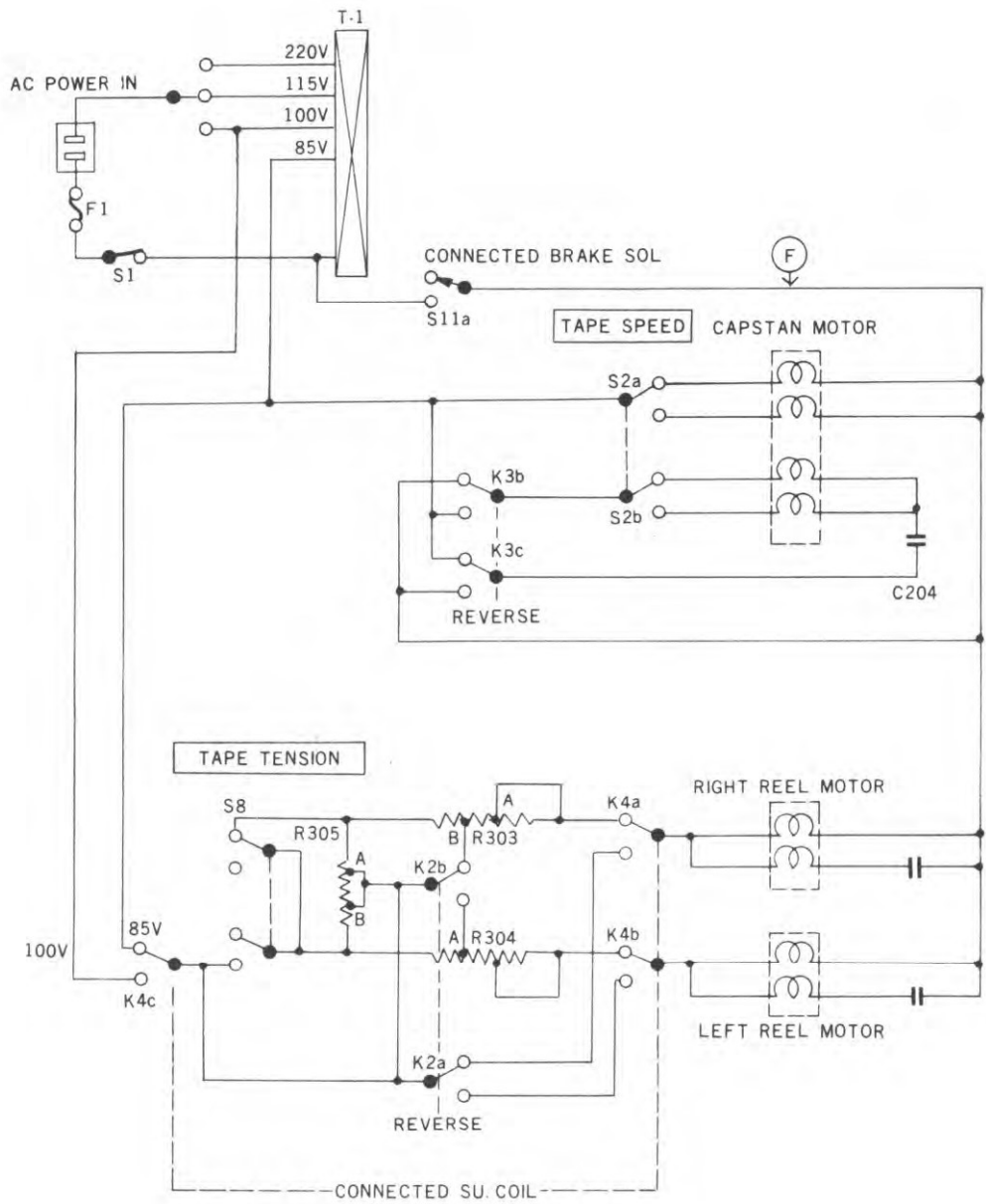

FIG.20 LUBRICATION

TROUBLE SHOOTING PARTS

MALFUNCTION	POSSIBLE SOURCE OF TROUBLE	CORRECTIVE PROCEDURE
Capstan fails to turn in play mode	Remote control jumper plug not installed or loose, line fuse F-1, belt off or slipping, capstan motor defective, capstan bearing defective, reverse relay (K-3), tape speed switch (S-2), phase capacitor (C-204)	Replace or repair defective components. Refer to simplified diagram
Pinch roller fails to contact capstan in play mode.	Pinch roller pressure incorrect, voltage selector switch in wrong position, fuse (F-3), diode (D-1), capacitor (C-202), pinch roller solenoid defective	The normal D.C. resistance of the pinch roller solenoid is 1.3 K ohms. Replace or repair defective components. Refer to simplified diagram
Takeup motor does not operate or operates with improper tension in the forward mode	Right motor defective, switch coil (K-4), resistor (R-303), voltage selector switch in wrong position	Replace or repair defective components. Refer to simplified diagram
Supply motor does not operate or operates with improper tension in the forward mode.	Left motor defective, switch coil (K-4), resistor (R-304), voltage selector switch in wrong position	Replace or repair defective components. Refer to simplified diagram
Tape speed not normal or excessive wow and flutter	Belt on wrong pulley step, oil on belt or pinch roller, defective pinch roller or belt, belt loose, belt not aligned, improper pinch roller pressure NOTE: The capstan motor will not cause wow and flutter.	Clean, adjust or replace defective drive components.
Tape damage	Reel defective, reel height incorrect, excessive takeup tension, excessive holdback tension, brake tension not even	Repair or adjust defective components.
No automatic reverse. Operates normally when reverse button is pressed.	Sensing post dirty, foil length too short, foil defective, sensing relay (K-1), fuse (F-2)	Repair or replace defective components. Refer to simplified diagram
Tape squeal	Poor tape, heads or pinch roller dirty, excessive holdback tension	Clean, adjust or repair defective components.
Fast wind inoperative	Switch coil (K-4) defective, button assembly defective, button assembly switch alignment NOTE: If K-4 is defective, the FAST button will not stay in.	Repair or replace defective components. Refer to diagram
No playback	Interconnecting cords out or loose, fuse (F-2), head dirty or defective, playback amp defective	Refer to block diagram and playback amplifier voltage diagram
Playback Hissing noise	Bad tape, improper level during record, equalization switch (S-2) NOTE: A highly efficient tweeter in the speaker system will cause hiss to be prominent.	Decrease tweeter level, record at a higher level, replace or repair defective components.

Loss of high frequencies	Heads dirty or magnetized, heads worn or out of alignment	Clean, demagnetize or replace defective head.
Channels unbalanced during playback	Heads dirty, heads worn, playback level adjustment, voltage switch in wrong position	Repair, replace or adjust defective components.
Crosstalk between forward and reverse tracks	Head switching relay (K-7)	Replace or clean relay.
No record	Interconnecting cables loose or out, capacitors (C-136), (C-137), switch (S-10), (S-13), (S-14), relay (K-5) or (K-6), head dirty or defective, record amp defective, bias oscillator defective	Repair or replace defective components. Refer to simplified diagram and voltage diagram
Loss of high frequencies during record	Head dirty or magnetized, head defective	Clean and demagnetize head.
Partial or No erase	Erase head dirty, bias oscillator defective	Clean head. Refer to page 35
No VU light	Bad lamp. The life expectancy of the VU lamp is 200 to 500 hours.	To replace the lamp—turn off power, pull off the plastic VU meter cover. Fold the wires holding the lamp forward. Solder in new lamp with low heat iron. Fold wires back. Replace cover.
Channels not balanced during record	Head dirty or defective bias, out of adjustment, record level calibration	Clean head. Adjust bias oscillator or record level calibration



AC POWER DISTRIBUTION FOR MOTORS

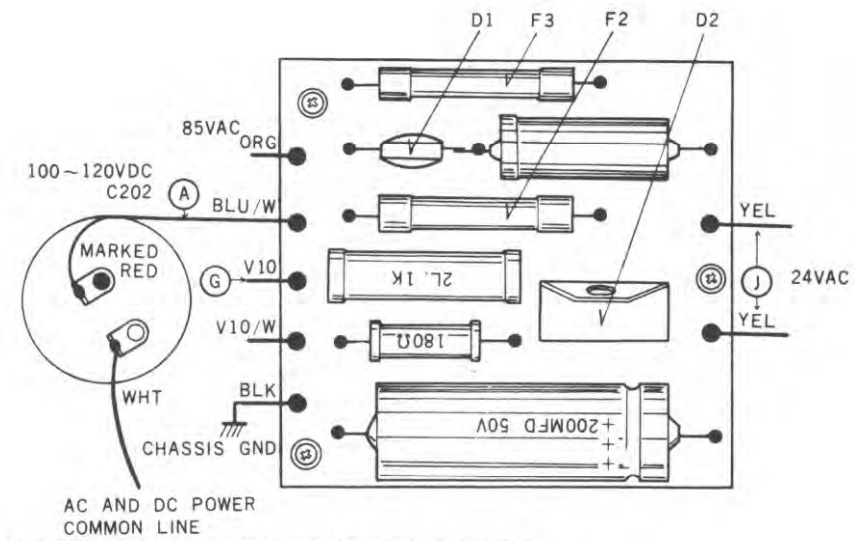

RECTIFIER ASS'Y PRINTED BOARD

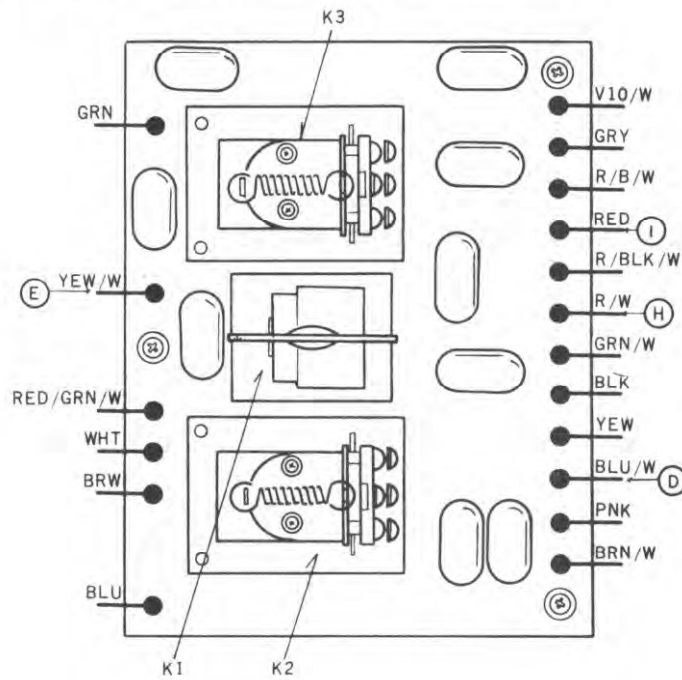

RELAY ASS'Y PRINTED BOARD

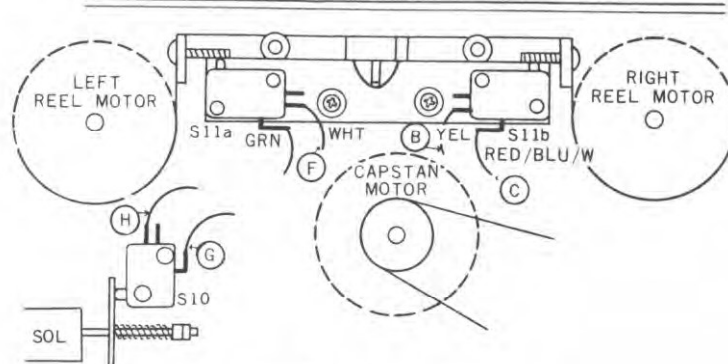

LOCATION OF CONTROL SWITCHES

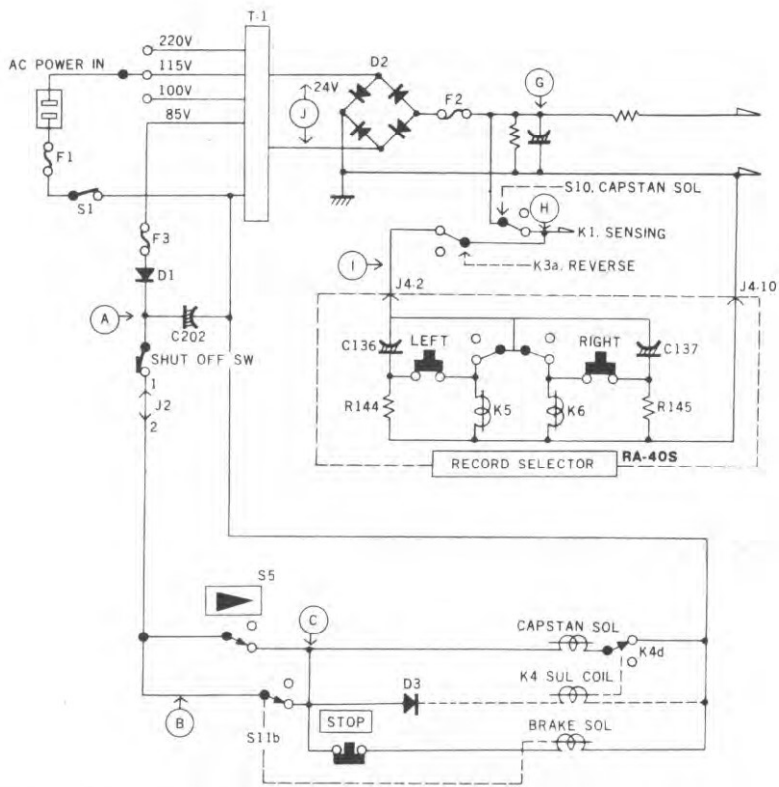

FORWARD PLAY AND RECORD MODE

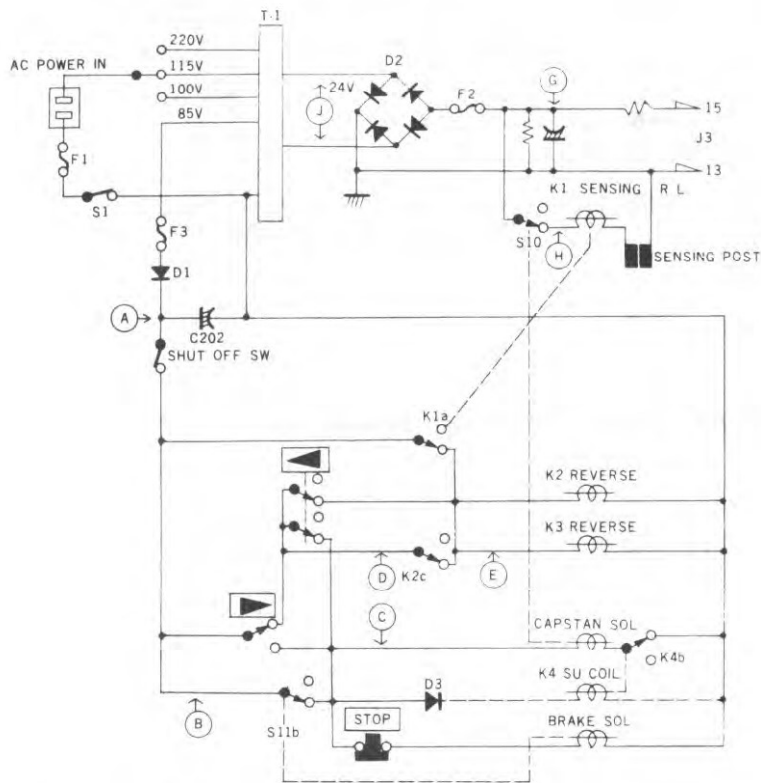

REVERSE PLAY MODE

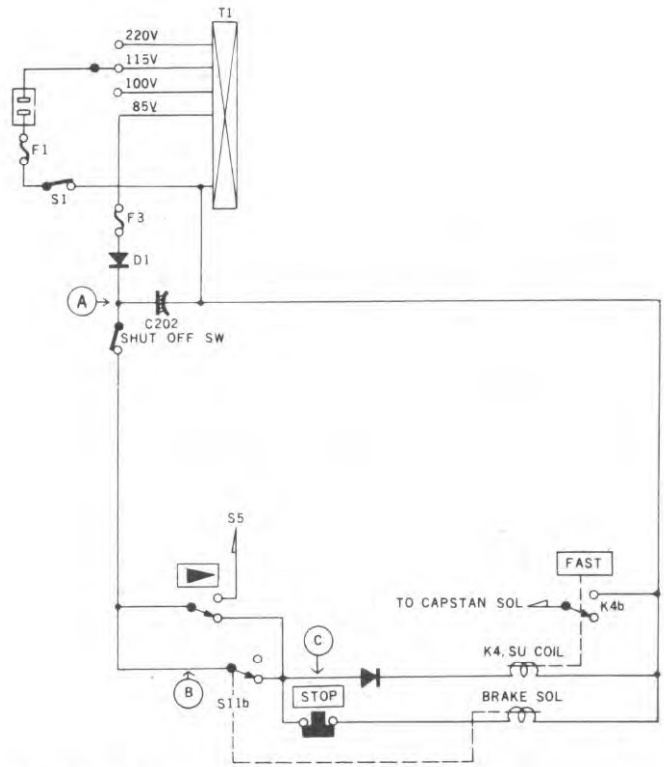

FAST FORWARD MODE

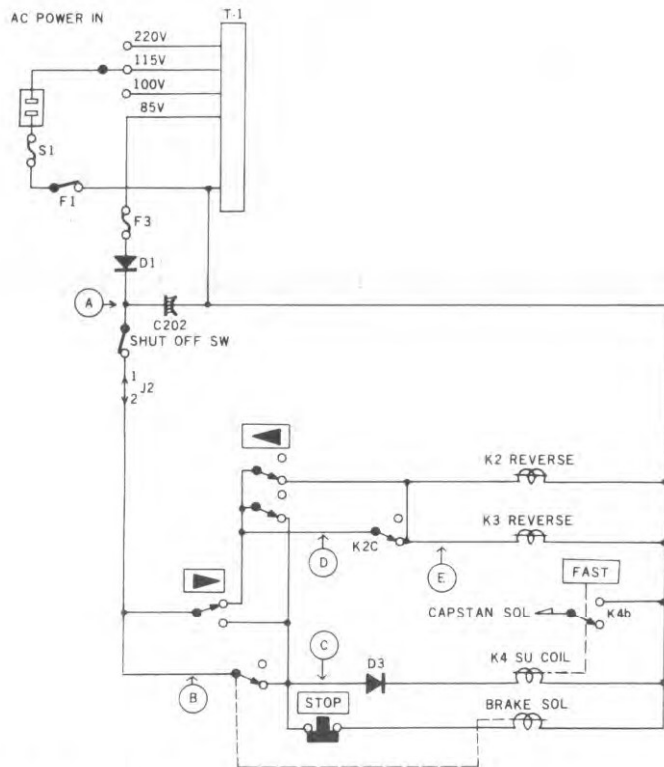

REWIND MODE

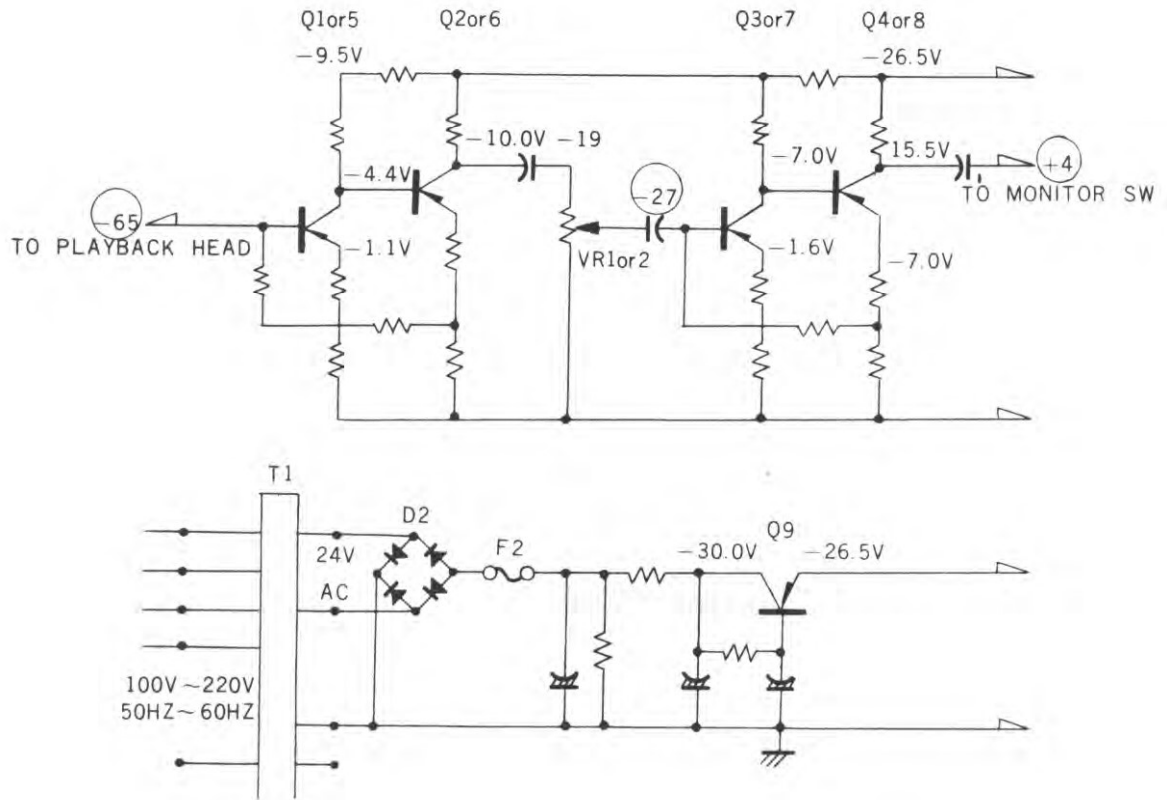

A-4000S PLAYBACK AMPLIFIER LEVEL AND DC VOLTAGE CHART

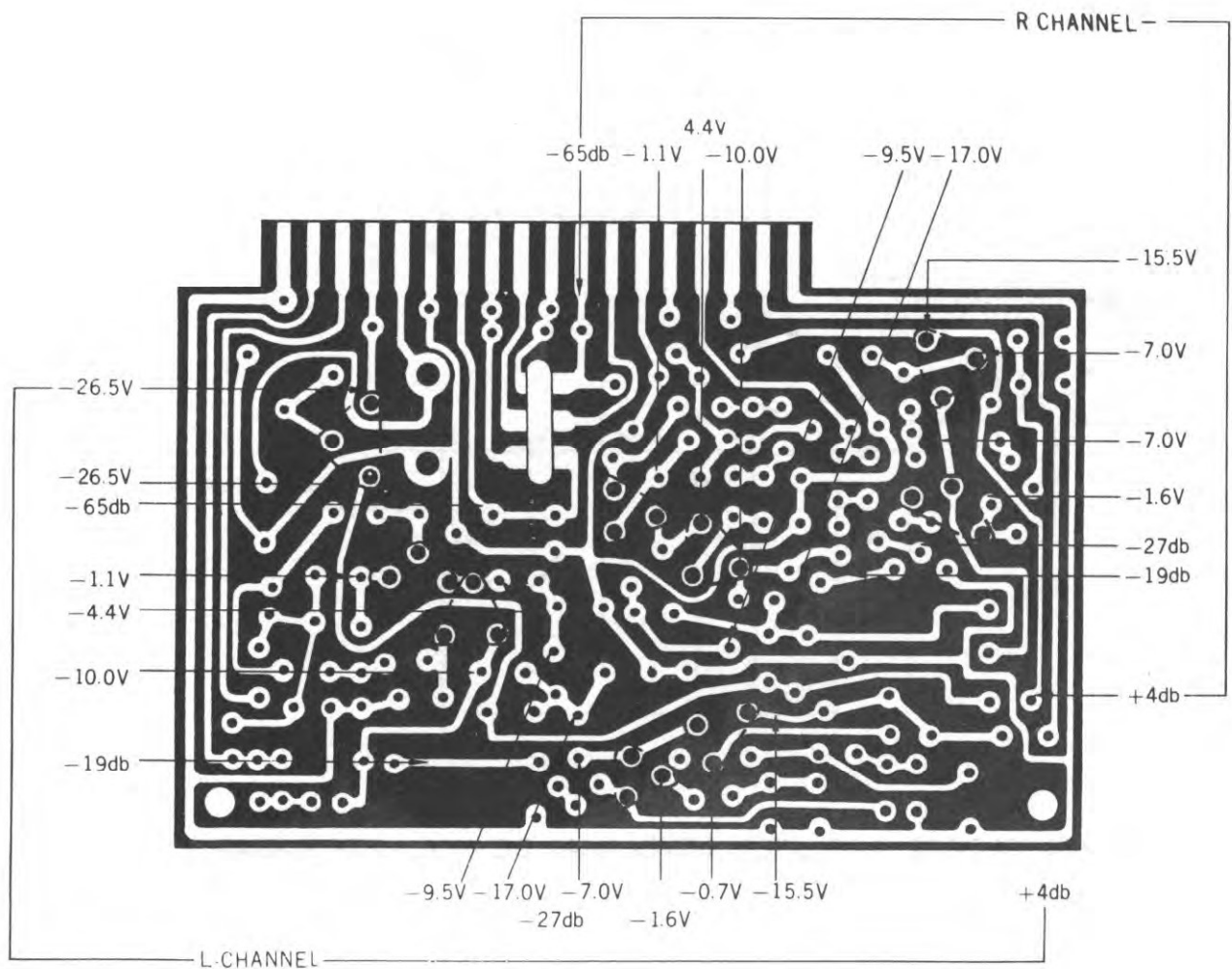
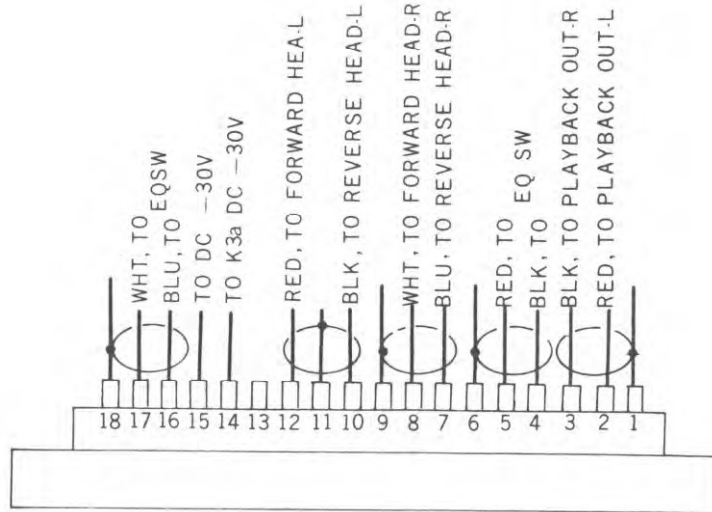

NOTE : ALL VOLTAGES ARE MEASURED IN RESPECT TO GROUND WITH A 20KΩ PER VOLT METER.
 ALL GAIN LEVELS ARE MEASURED WHILE PLAYING A 500HZ REFERENCE SIGNAL RECORDED AT NORMAL OPERATING LEVEL.

**A-4000S PLAYBACK AMPLIFIER PRINTED BOARD
 CHECKING POINTS FOR LEVEL AND DC VOLTAGE**

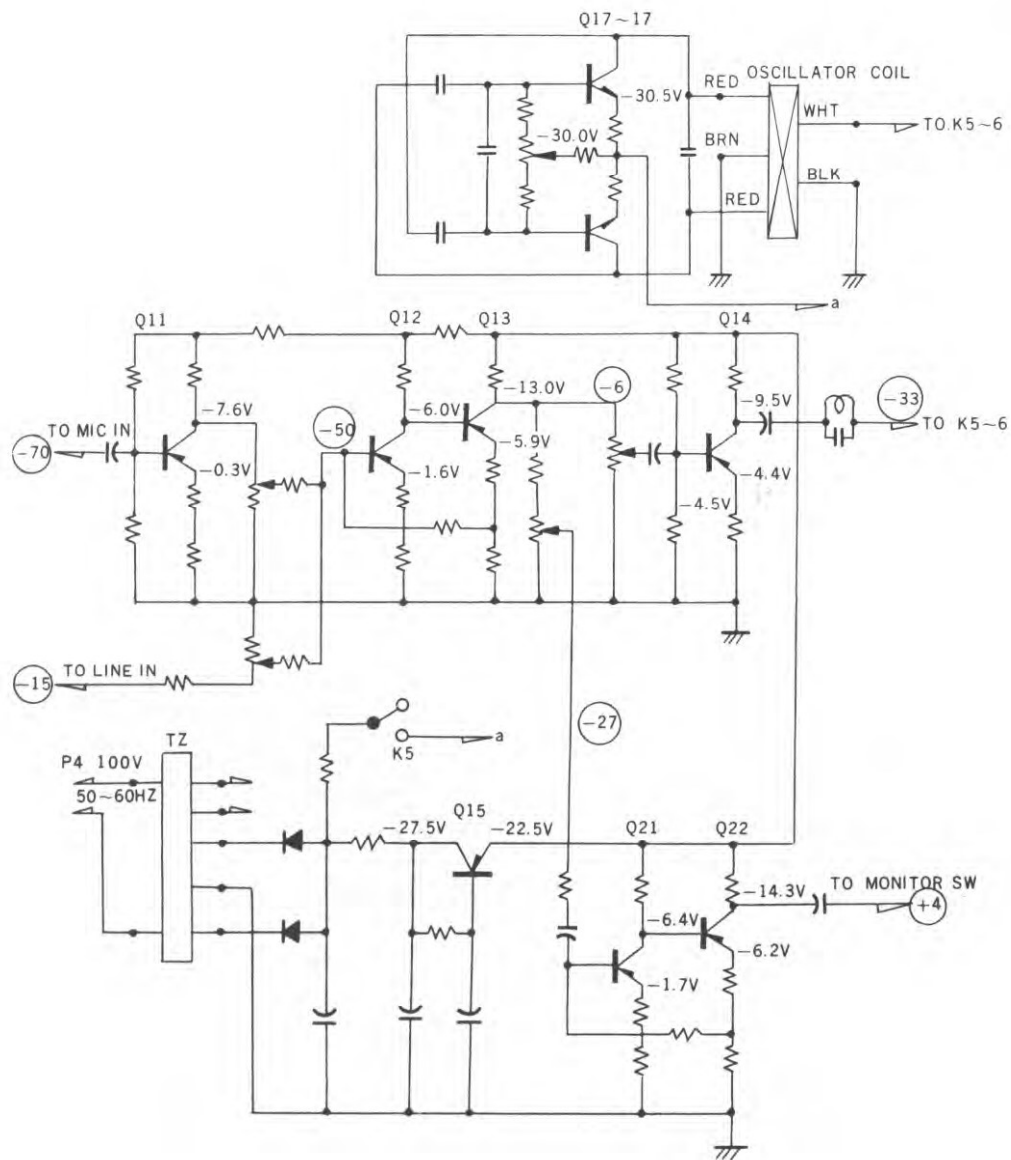

RA-40S RECORD AMPLIFIER LEVEL AND DC VOLTAGE CHART

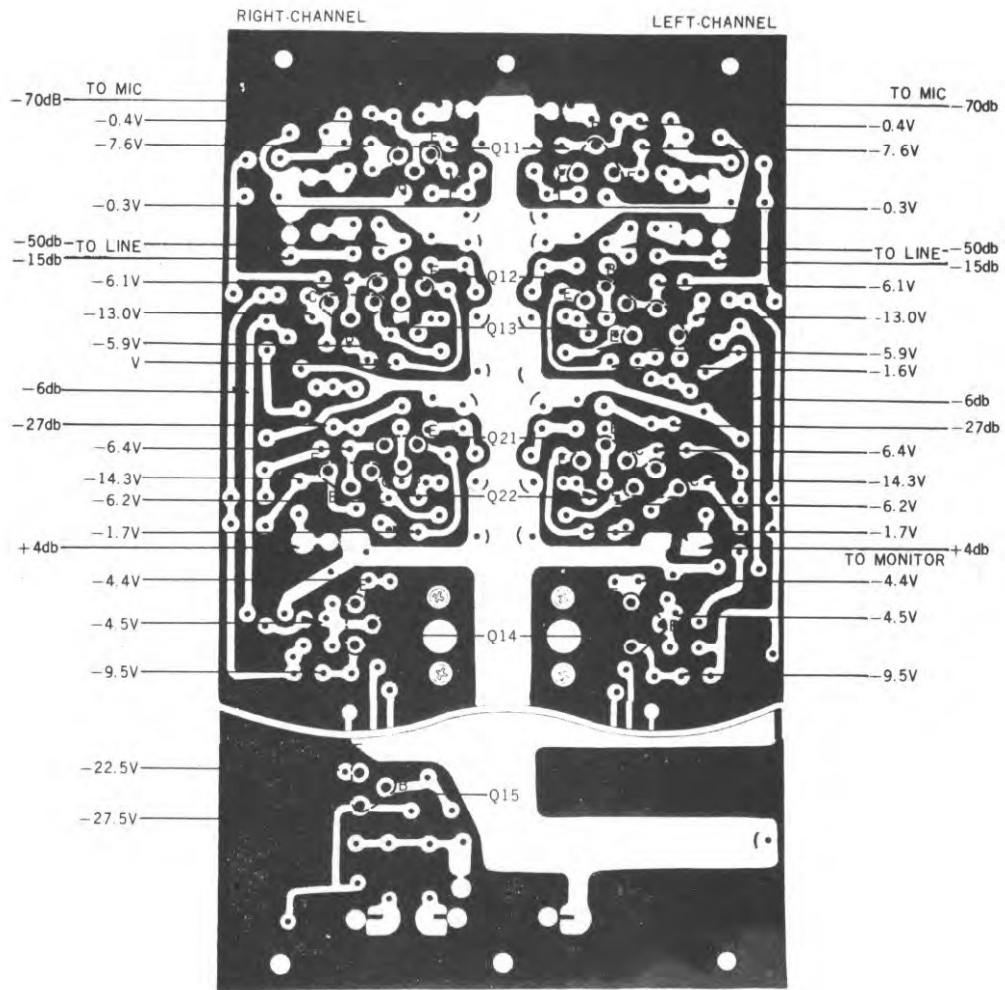

RECORD AND MONITOR

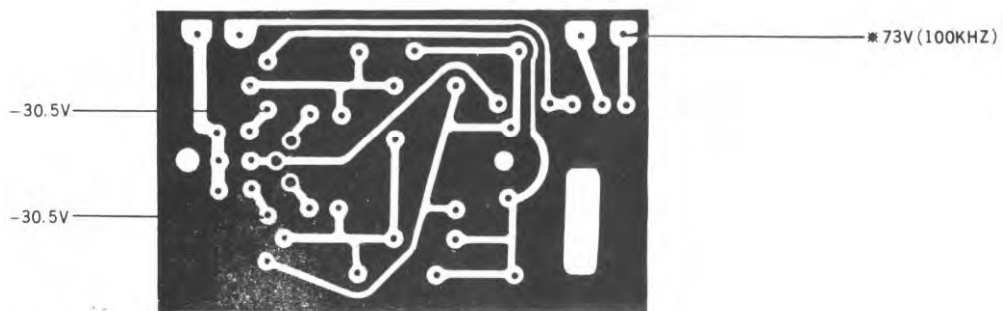

BIAS AND ERASE OSCILLATOR

* MEASURED WITH VTVM DURING RECORD OPERATION

RA-40S PRINTED BOAD (BOTTOM)

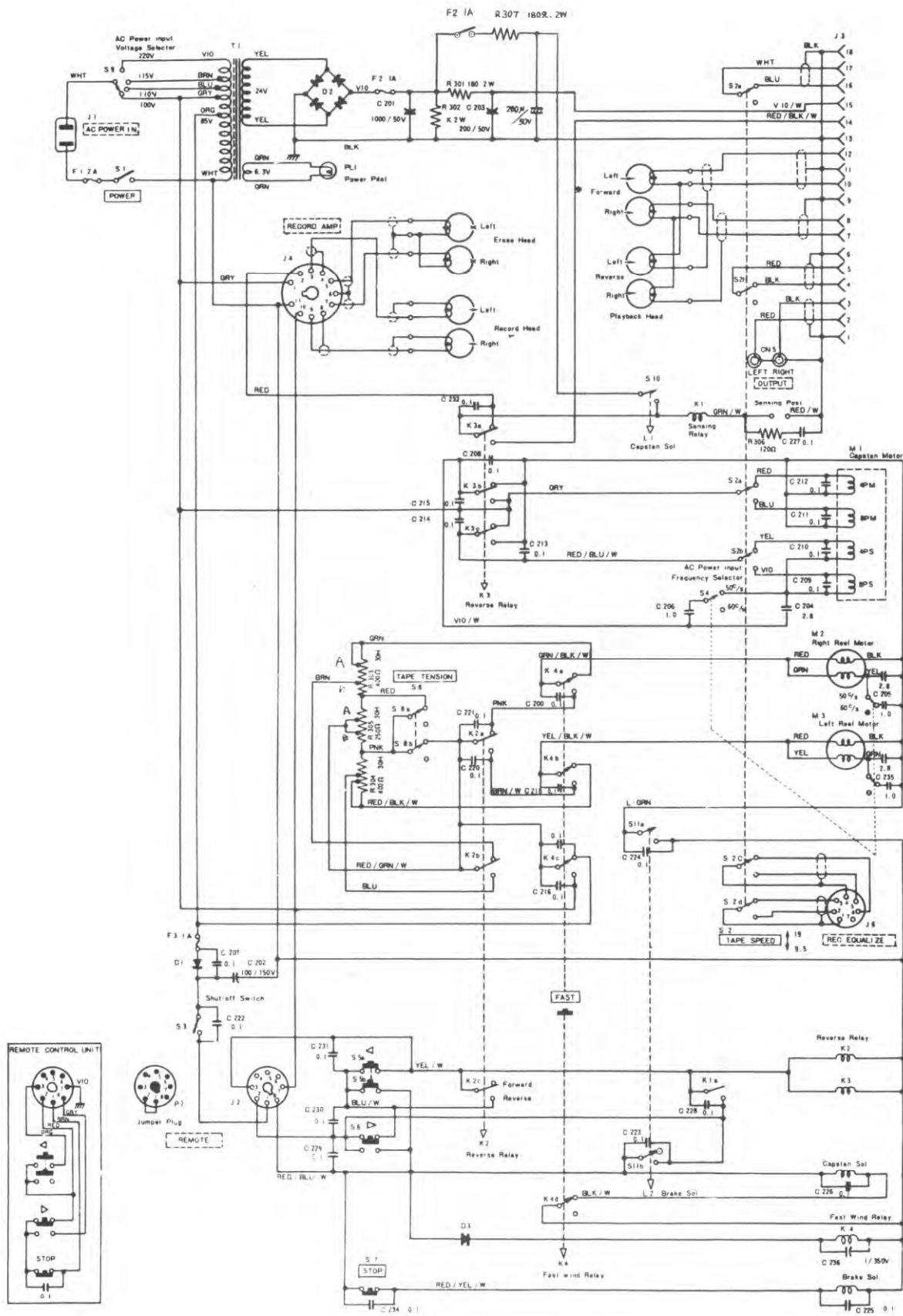

A-4000S TAPE PLAYER, TAPE TRANSPORT MECHANISM SCHEMATIC DIAGRAM

NOTE: COMPONENT VALUES ARE SUBJECT TO CHANGE WITHOUT NOTICE.

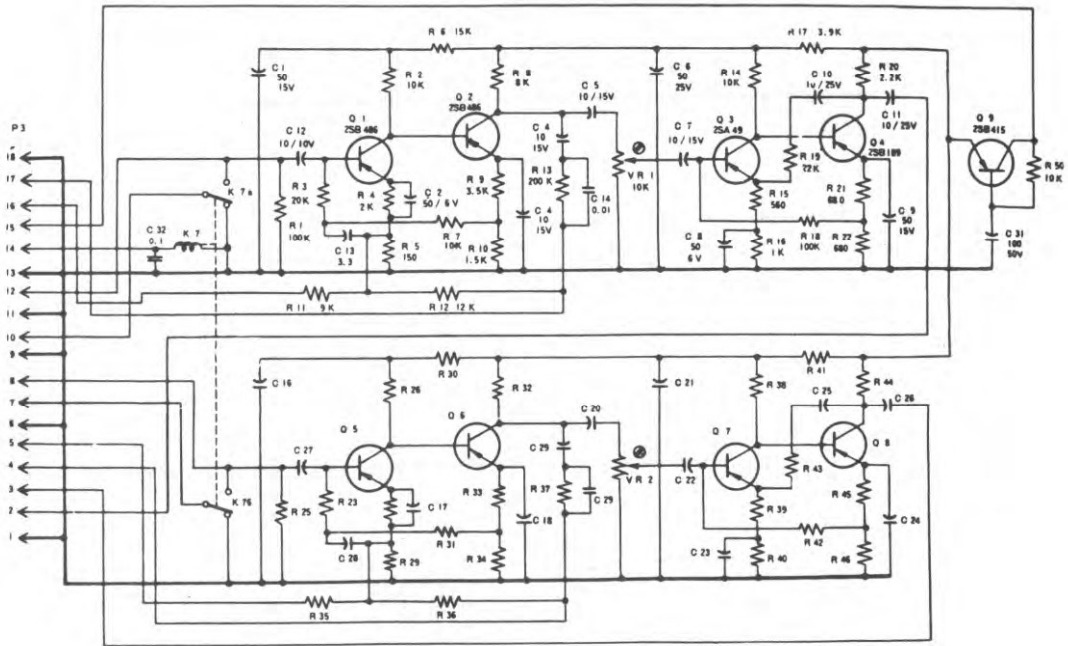

A-4000S TAPE PLAYER, PLAYBACK AMPLIFIER SCHEMATIC DIAGRAM

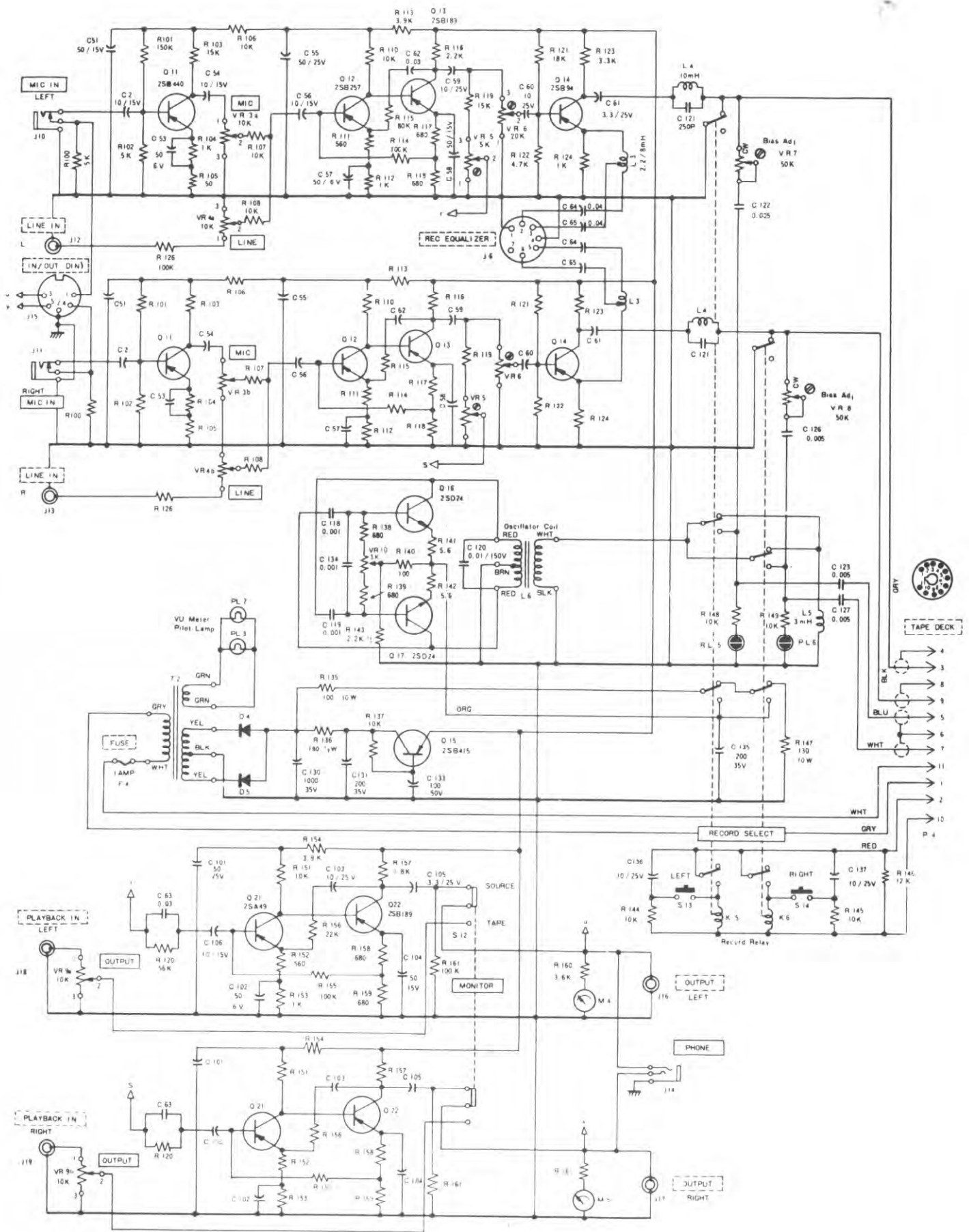

RA-405 RECORDING AMPLIFIER SCHEMATIC DIAGRAM

NOTE: COMPONENT VALUES ARE SUBJECT TO CHANGE WITHOUT NOTICE

A-4010 AND A-4010S COMPARISON CHART

Revised Item	RECORD AMPLIFIER	
	RA-40	RA-40S
Monitor Switch	TAPE-up	TAPE-down
	SOURCE-down	SOURCE-up
Record Indicator Light	Square edges	Rounded edges
Record Button	Raised Skirt	No Skirt
Microphone Jack Washers	Clear	Black
Front Panel	Flush with edge trim	Recessed
Rear Connection Plate	On metal chassis	On black phenolic
	TRANSPORT	
	A-4000	A-4000S
Rear Connection Plate	On metal chassis	On black phenolic
Front Panel	Flush with edge trim, rounded top and bot- tom edge	Flat recessed plate
Cast Capstan Mounting Base	3 screws used	4 screws used
Capstan Assembly	Single oilless front bearing	Extra rear bearing used
Reel Motors	4 pole motor	6 pole outer rotor motor
Playback Head	4,500 ohm (66901)	700 ohm at 1 KHz (66903)
Playback Amplifier Transistors	Q-1, 2, 5, 6 2SB257 Q-4 2SB189	Q-1, 2, 5, 6 2SB486 Q-4 2SB405
Equalizer Components	R-11 R-35 4.5K ohms R-12 R-36 6K ohms C-14 C-29 .02 mf	R-11 R-35 9K ohms R-12 R-36 12K ohms C-14 C-29 .01 mf
Output Level	O VU obtained at graduate 6 to 7	O VU obtained at maximum level
DIN Input	Parallel to LINE input	Parallel to MIC input
Record Indicator Lamp	Filament	Neon
Dummy Load for Monaural	Not used	Used

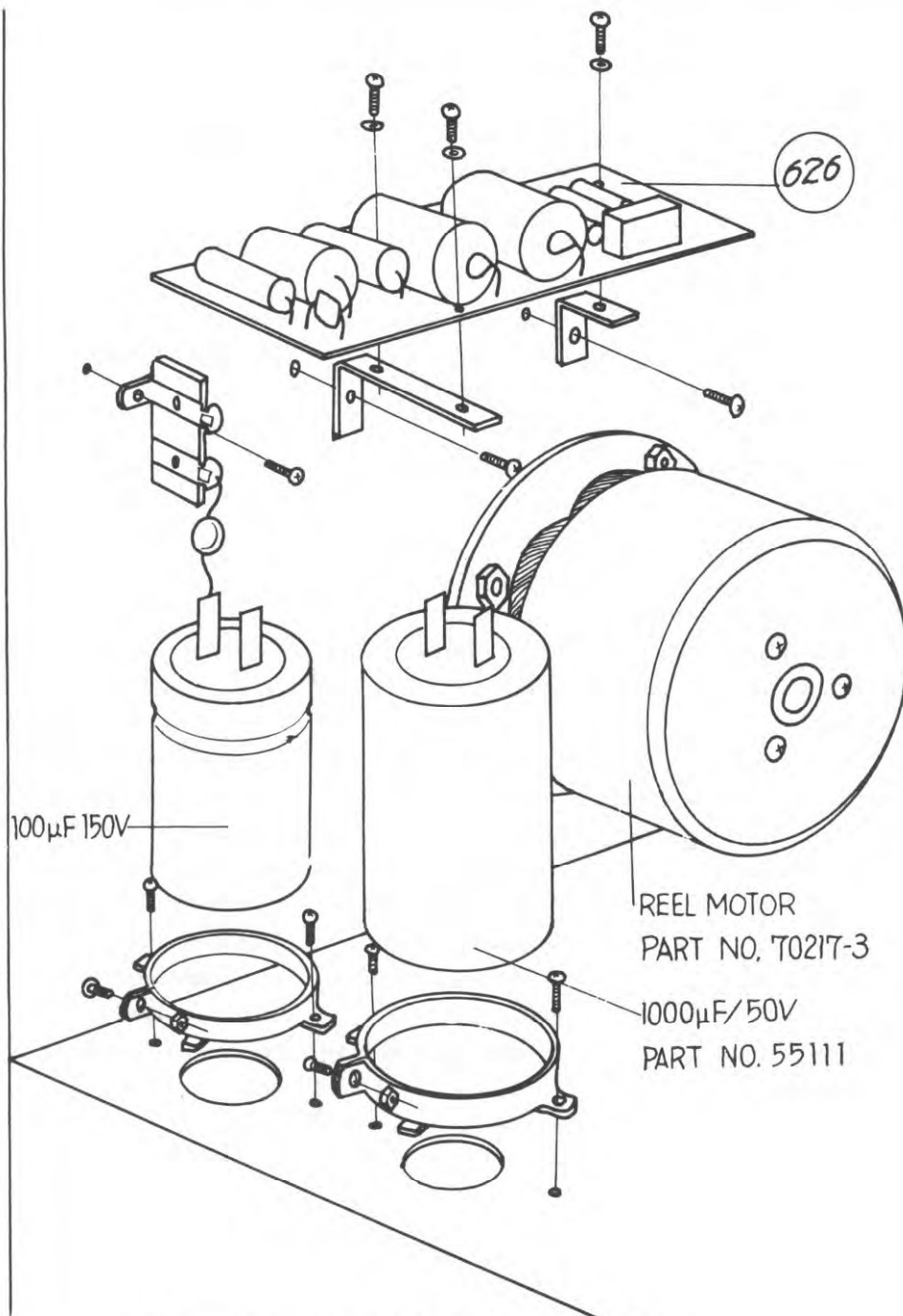

For series number 23360 or later

RIGHT CHASSIS ASS'Y

TRANSPORT-BOTTOM

REF. NO.	PART NO.	DESCRIPTION	1st Revision	2nd Revision	3rd Revision
9	70111	Capstan Motor	70112	70114	70116-3
10	12250	Fan	12398		
84	70214	Reel Motor	70217-3		
85	45202	Tarminal Strip 1L-3P (Left)			
91	11133	Transport Chassis	11233-1	11245-3	
97	27048	Rubber Grommet			
200	56133	Power Transformer	56138-1	56138-2	
201	27198	Resistor Retaining Plate			
202	52416	Tape Tension Adjust Resistor 250Ω 30W			
203	52409	Back Tension Adjust Resistor 400Ω 30W			
204	44325	Speed Selector Switch			
205	54537	Capacitor Ass'y(Capacitor 0.1MF Tubular)			
206	54533	Capacitor 2.8M + 1M/250V MP			
207	54539	Capacitor 2.8 + 1/250V x 2	54548(3 μ + 1 μ/250Vx2)		
208	27145	Wire Retainer			
400	44323	Transport Selector Switch Ass'y	25042		
600	23181	Back Cover			
613	23160	Left Chassis			
615	48804	Relay Printed Board Ass'y	48866		
616	23161	Right Chassis			
626	39016	Power Supply Printed Board Ass'y			
250	27283	Thrust Plate			
251	27279	Thrust Plate, Nylon			
252	27285	Thrust Plate, Steel			

TRANSPORT-TOP

REF. NO.	PART NO.	DESCRIPTION	1st Revision	2nd Revision	3rd Revision
60	18024	Shut-off Arm Ass'y			
61	18014	Shut-off Arm			
62	18208	Stop-Ring			
63	22034	Arm Spring			
64	18227	Arm Cover			
65	18215	Stopper			
66	44611	Shut-off Switch	44613		
67	18216	Magnet			
68	18217-2	Magnet Catcher			
69	18176	Shut-off Arm Shaft			
70	18032-4	Tension Arm Ass'y			
80	16140	Reel Holder	16158		
81	16155-2	Reel Table			
82	17185	Brake Drum			
83	17172	Brake Guard			
84	70214	Reel Motor	70217-3		
86	58505	Index Counter			
87	27199-1	Counter Retainer			
88	27142	Counter Belt			
89	44324	Tension Switch			
90	11159	Face Plate			
91	11133	Transport Chassis	11233	11245-3	
92	14152-1	Roller Arm Shaft			
93	41503	Lamp Holder	43114		
94	41413	Lamp			
95	25110	Speed Selector Button			
96	25160	Speed Selector Switch Lever			
97	27048	Rubber Grommet			
98	44321	Power Switch			
99	27259-1	Power Switch Holder			
100	13014	Head Ass'y			
120	13357-2	Head Housing			
121	13368	Head Housing Face Plate			
125	11162-1	Sash A			
126	11163-1	Sash B			
209	11693	Stiffener			
7	12256-2	Motor Pulley	12342-1	12379	
8	12225	Capstan Drive Belt	12321-3		
11	12248	Dust Cap			
12	12260	Capstan Base			
15	15007	Tape Lifter Ass'y			
9	70111	Capstan Motor	70112	70114	70116-3
255	27248	Lamp Holder Retainer			
25	14009	Pinch Roller Ass'y	14020		
26	14142	Roller Arm	14160-2		
27	15012	Pinch Roller Link Arm	15173		
50	17003	Brake Mounting Base Ass'y			
400	44323	Transport Selector Switch Ass'y	25042		

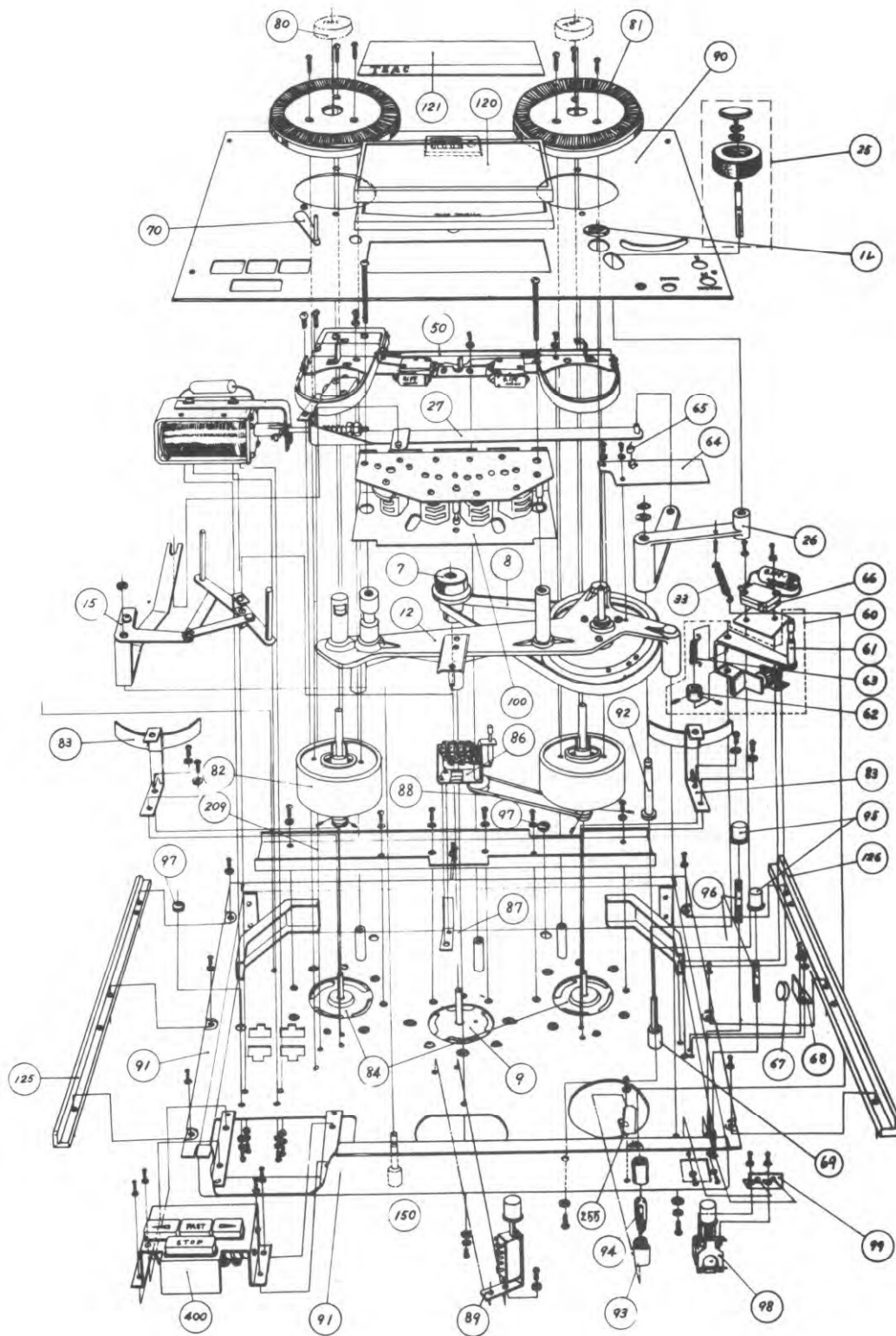

A-4000S TRANSPORT-TOP, EXPLODED VIEW

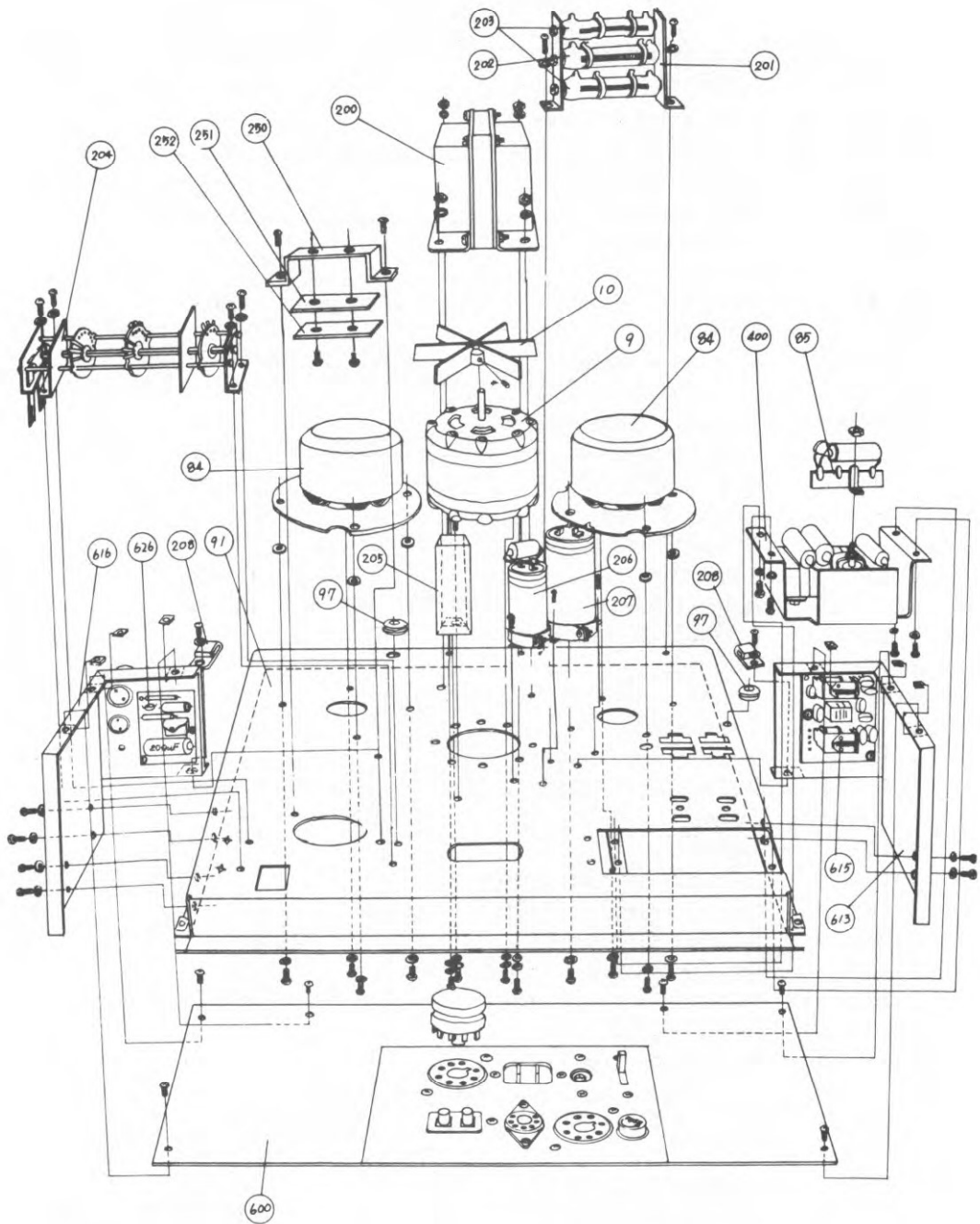

A-4000S TRANSPORT-BOTTOM, EXPLODED VIEW

TRANSPORT SELECTOR SWITCH ASS'Y

REF. NO.	PART NO.	DESCRIPTION	1st Revision	2nd Revision	3rd Revision
400	25027	Transport Selector Switch Ass'y			
405	44948	Switch Mounting Chassis			
406	21006	Special Screw M3 x 95			
407	24058	Leg			
408	44610	Micro-switch			
409	44613	Micro-switch			
410	54102	Capacitor 0.1MF Tubular			
413	44943	Push Plate Ass'y			
414	44945	" "			
415	27187	Cushion			
416	44932-1	SU Solenoid Retaining			
417	61618	SU Solenoid			
421		Nut M4			
401	27186	Rubber Sheet			
402	25235	Direction Button			
403	25236	Fast Button			
404	25237	Stop Button			
85	45202	Terminal Strip 11-3P (LEFT)			
422	42210	Rectifier FR-1K			
423	54535	MP Capacitor 1 μ F			

BACK PLATE ASS'Y

REF. NO.	PART NO.	DESCRIPTION	1st Revision	2nd Revision	3rd Revision
600	23181	Back Cover			
601	41207	Fuse Post			
602	41114	Fuse 2A			
603	43235	Socket 11P			
604	43415	Socket 7P			
605	43617	Connector 18P			
606	43444	Pin Jack			
607	43406	GT Socket			
608	43105	AC Receptacle			
610	48805	Pre-amplifier Ass'y			
611	44212	Voltage Select Switch	44219(Serial No. 21959 and after)		
612	44407	Cycle Select Switch			
614	27016	Rubber Cushion			
630	26093	Back Dress Panel Jumper Plug			
631	99006	Transistor 2SB486			
		Transistor 2SA49			
		Transistor 2SB189			
		Transistor 2SB415			

LEFT CHASSIS ASS'Y

REF. NO.	PART NO.	DESCRIPTION	1st Revision	2nd Revision	3rd Revision
613	23160	Left Chassis			
614	27016	Rubber Cushion	27189		
615	39013	Relay Printed Board Ass'y			

RIGHT CHASSIS ASS'Y

REF. NO.	PART NO.	DESCRIPTION	1st Revision	2nd Revision	3rd Revision
614	27016	Rubber Cushion			
616	23161	Right Chassis			
617	55108	Capacitor 100MF/150V Electrolytic			
618	55102	Capacitor 1000 MF/50V Electrolytic			
623		Earth Terminal M4			
626	39016	Power Supply Printed Board Ass'y			

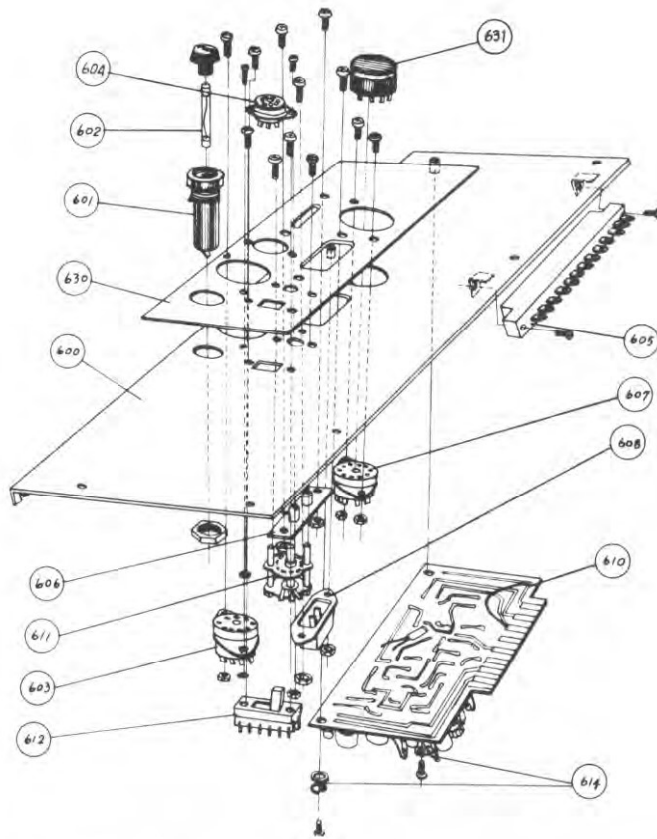

A-4000S BACK PLATE ASS'Y, EXPLODED VIEW

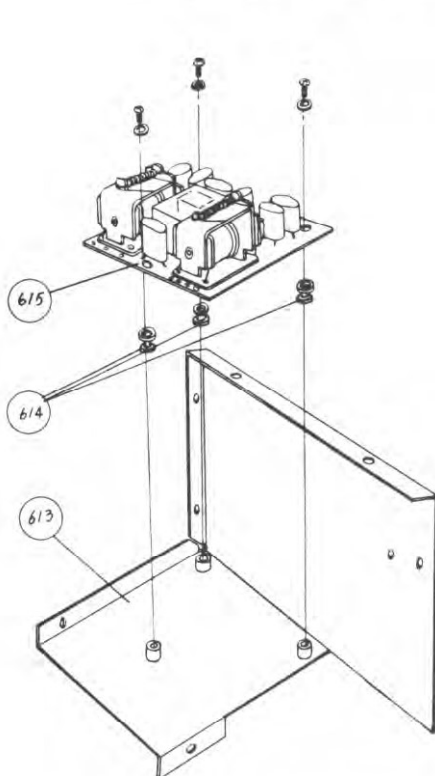

**A-4000S LEFT CHASSIS ASS'Y,
EXPLODED VIEW**

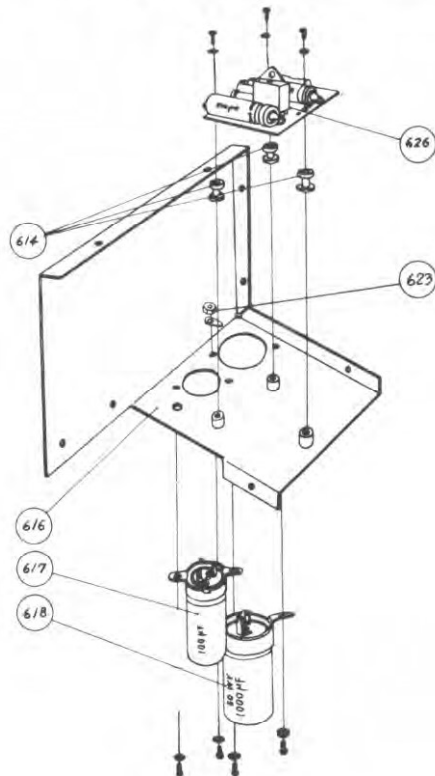

**A-4000S RIGHT CHASSIS ASS'Y,
EXPLODED VIEW**

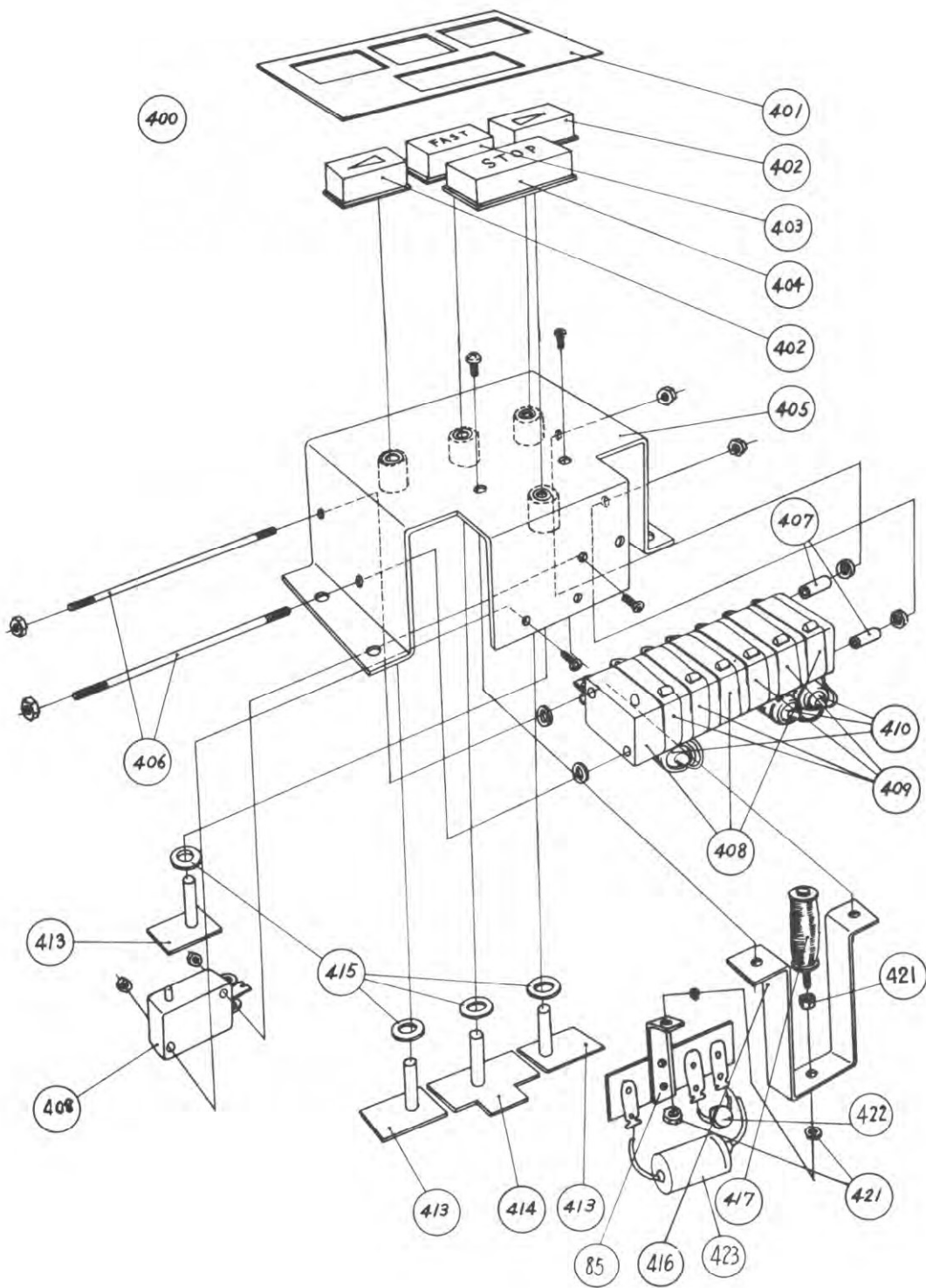

A-4000S TRANSPORT SELECTOR SWITCH ASS'Y, EXPLODED VIEW

TAPE LIFTER AND PINCH ROLLER LINK ARM ASS'Y

REF. NO.	PART NO.	DESCRIPTION	1st Revision	2nd Revision	3rd Revision
15	15007	Tape Lifter Ass'y			
16	15160-1	Lifter A			
17	15161-1	Lifter B			
18	15142	Lifter Retaining Plate			
702	21600	E-clip M2			
703	21601	" M3			
12	12260	Capstan Base			
19	15190	Lifter Lever			
20	15193	Lifter Arm			
26	14142	Roller Arm	14160-1		
27	15012	Pinch Roller Link Arm			
28	14150	Double Nut A 4mm			
29	14151	" B 4mm			
30	22004	Pressure Spring			
31	12153	Pressure Adjust Screw			
32	14153	Stopper			
33	22044-1	Spring			
704	21602	E-clip M4			
705	21603	" M5			
710		Fiber Washer M7			
800	27332	Felt Washer			
814	21544	Flat Washer M4			
58	61621-1	Solenoid Ass'y			
59	12155	Pin A			
751	21840	Pin M1			
40	14149	Micro-switch Retaining Plate			
41	44613	Micro-switch X-1A44			

CAPSTAN AND TAPE LIFTER ASS'Y

REF. NO.	PART NO.	DESCRIPTION	1st Revision	2nd Revision	3rd Revision
1	12267	Capstan Shaft Ass'y			
2	12263	Capstan Shaft	12272-6		
3	12265	Capstan Housing			
4	12262	Metal Bearing			
5	27273	Bearing Washer			
6	12266-3	Flywheel			
7	12261	Felt			
8	12255	Felt			
12		Capstan Base			
13	13333	Housing Leg	13429		
14	13335	Tape Guide			
15	15007	Tape Lifter Ass'y			
16	15160-1	Lifter A			
17	15161-1	Lifter B			
18	15142	Lifter Retaining			
702	21600	E-clip M2			
703	21601	" M3			

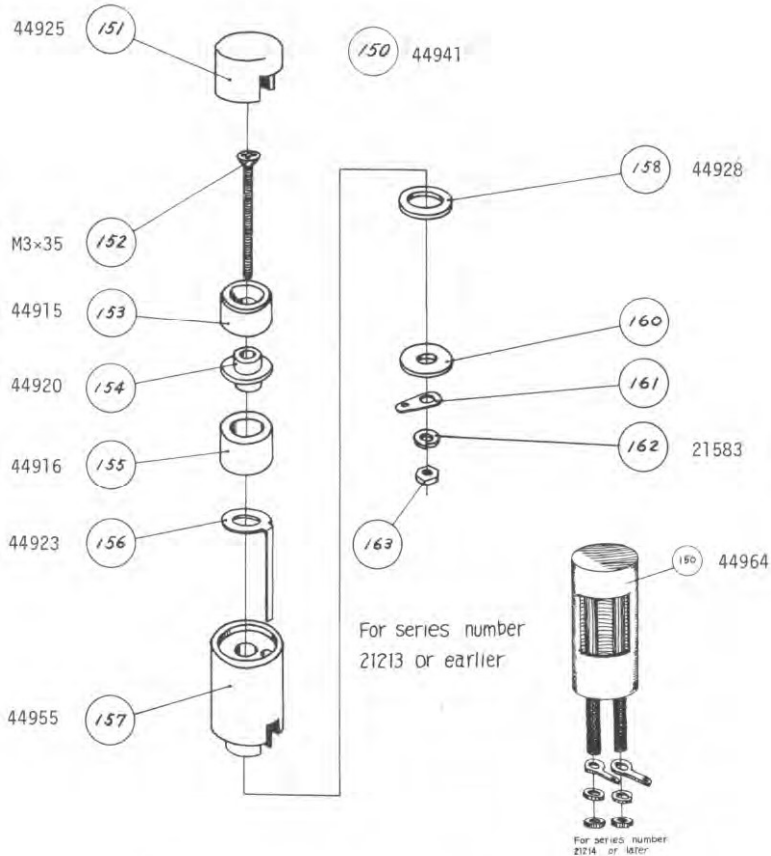

A-4000S SENSING POST ASS'Y, EXPLODED VIEW

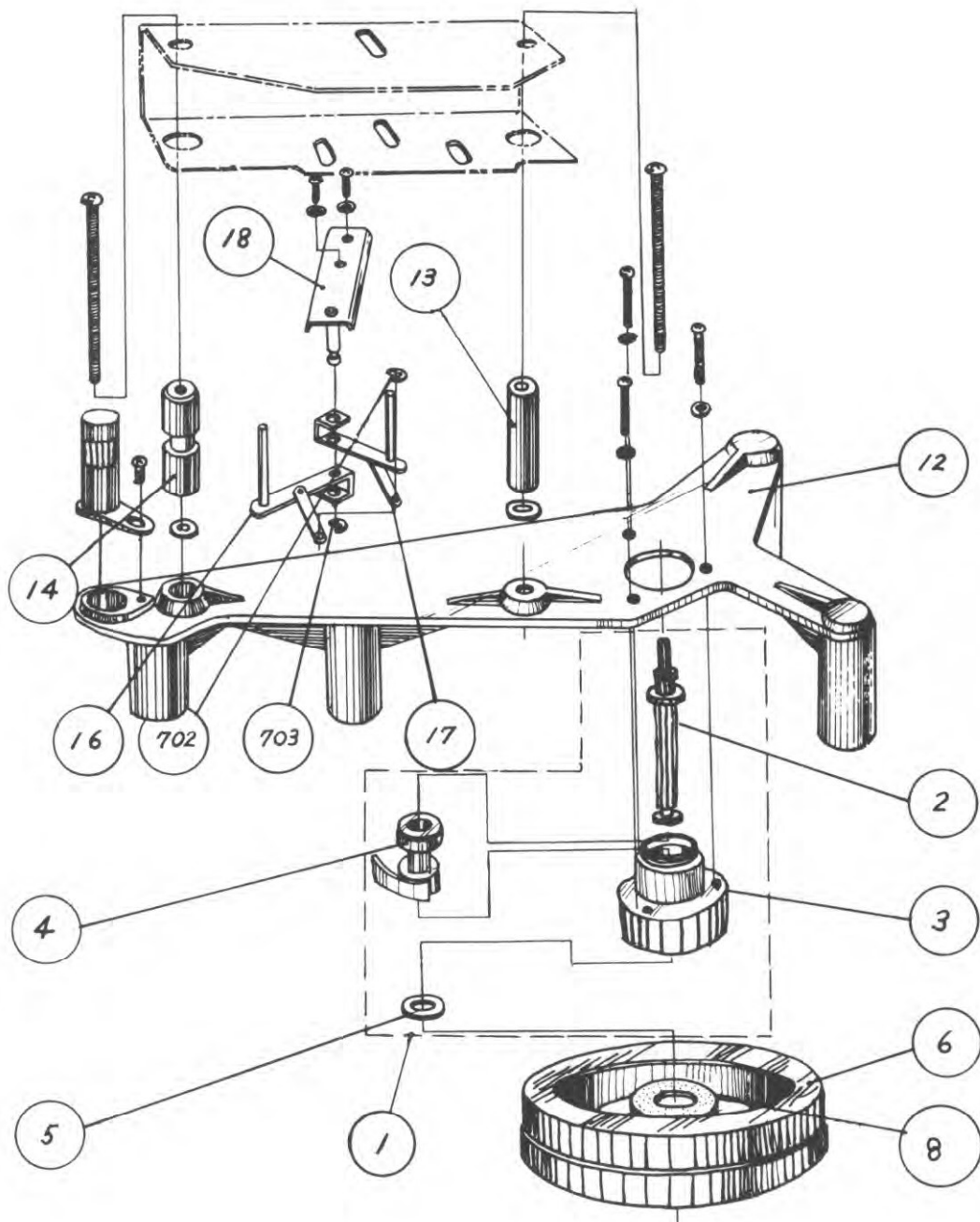

A-4000S CAPSTAN AND TAPE LIFTER ASS'Y, EXPLODED VIEW

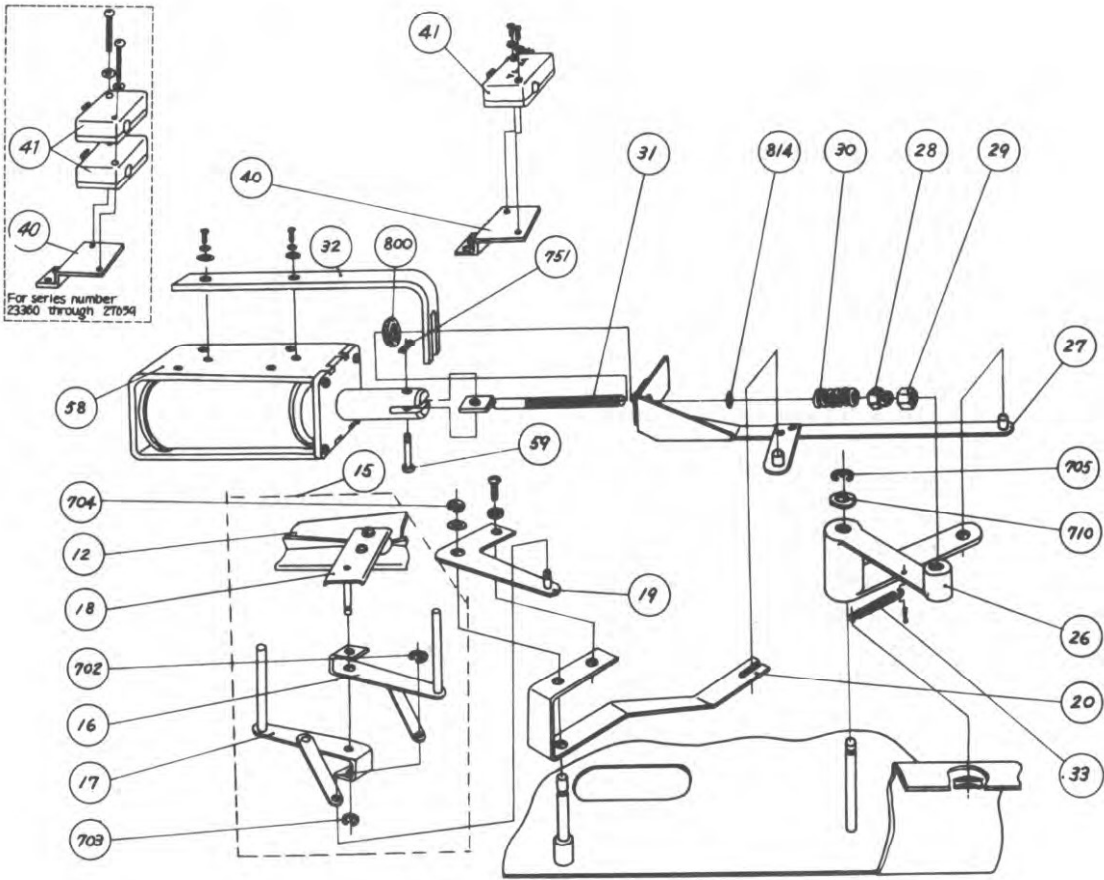

**A-4000S TAPE LIFTER AND PINCH ROLLER LINK ARM ASS'Y,
EXPLODED VIEW**

FACE PLATE ASS'Y

REF. NO.	PART NO.	DESCRIPTION	1st Revision	2nd Revision	3rd Revision
70		Tension Arm Ass'y			
71	18032-4	Tension Arm			
72	18182	Arm Holder			
73	18226	Felt			
74	18221	Tension Arm Base			
76	18207	Arm Holder Nut			
77	27239	Rabber Cushion			
78	18182	Spring Retaining Drum			
79	22051	Tension Arm Spring			
21	27181	Counter Escutcheon			
22	27180	Pilot Lamp Cap			
90	11159	Face Plate			

BRAKE ASS'Y

REF. NO.	PART NO.	DESCRIPTION	1st Revision	2nd Revision	3rd Revision
35	17001	Brake Band Ass'y			
36	17191	Brake Band			
37	17138-2	Brake Felt			
50	17007	Brake Mounting Base Ass'y			
51	17199	Brake Mounting Base	17200		
52	17201-1	Brake Lever A			
53	17202-1	" B			
54	17190	Left Brake Spring			
55	17189	Right Brake Spring			
56	17180	Brake Band Retainer			
57		Vinyl Pipe			
38	17203	Micro-switch Retaining Plate			
39	27179	Insulation Plate			
42	44613	Micro-switch			
45	54102	Capacitor 0.1MF			
58	61621-1	Solenoid Ass'y			
59	12155	Pin A			
813		Flat Washer M3			
751		Pin M1			

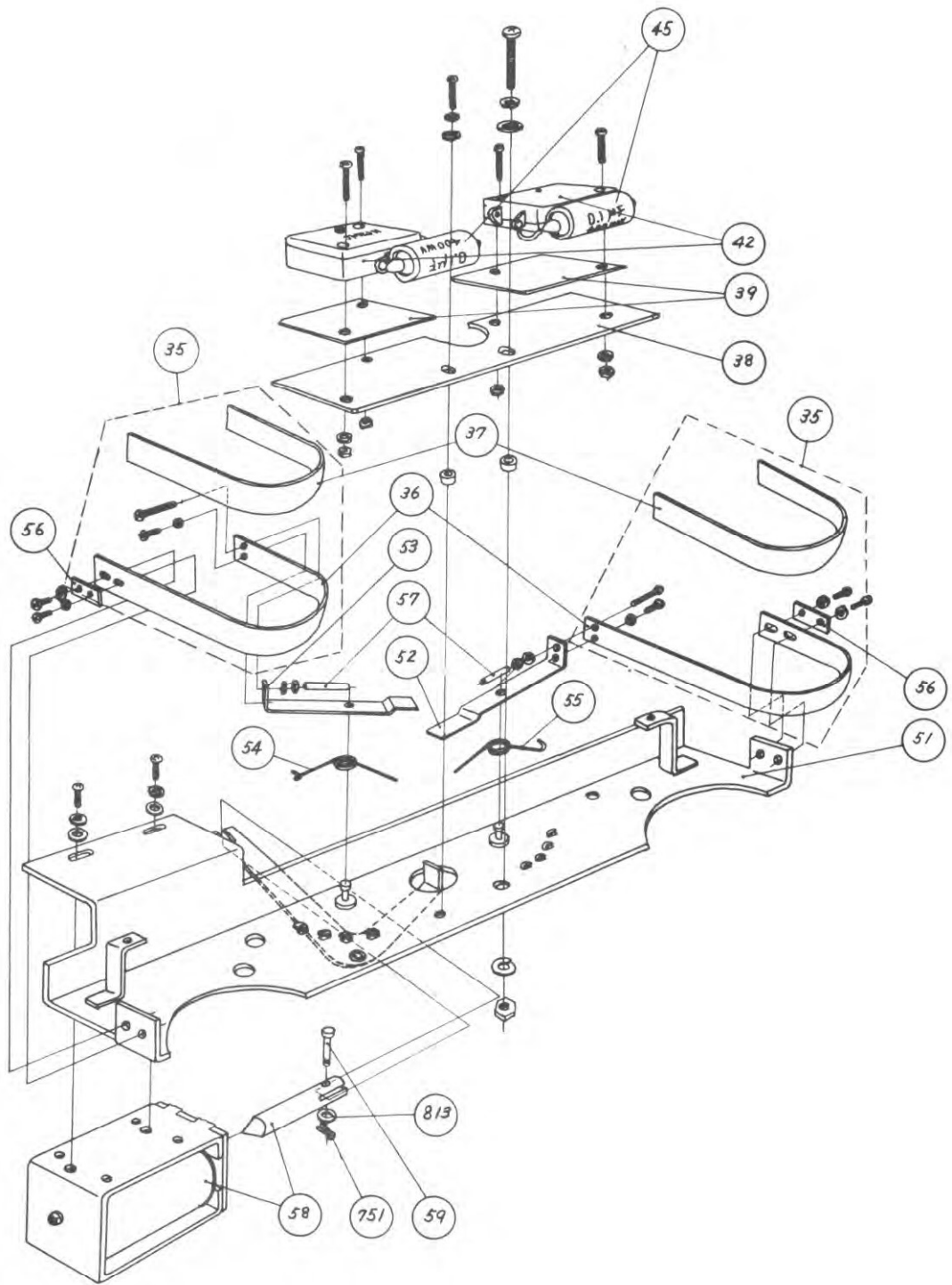

A-4000S BRAKE ASS'Y, EXPLODED VIEW

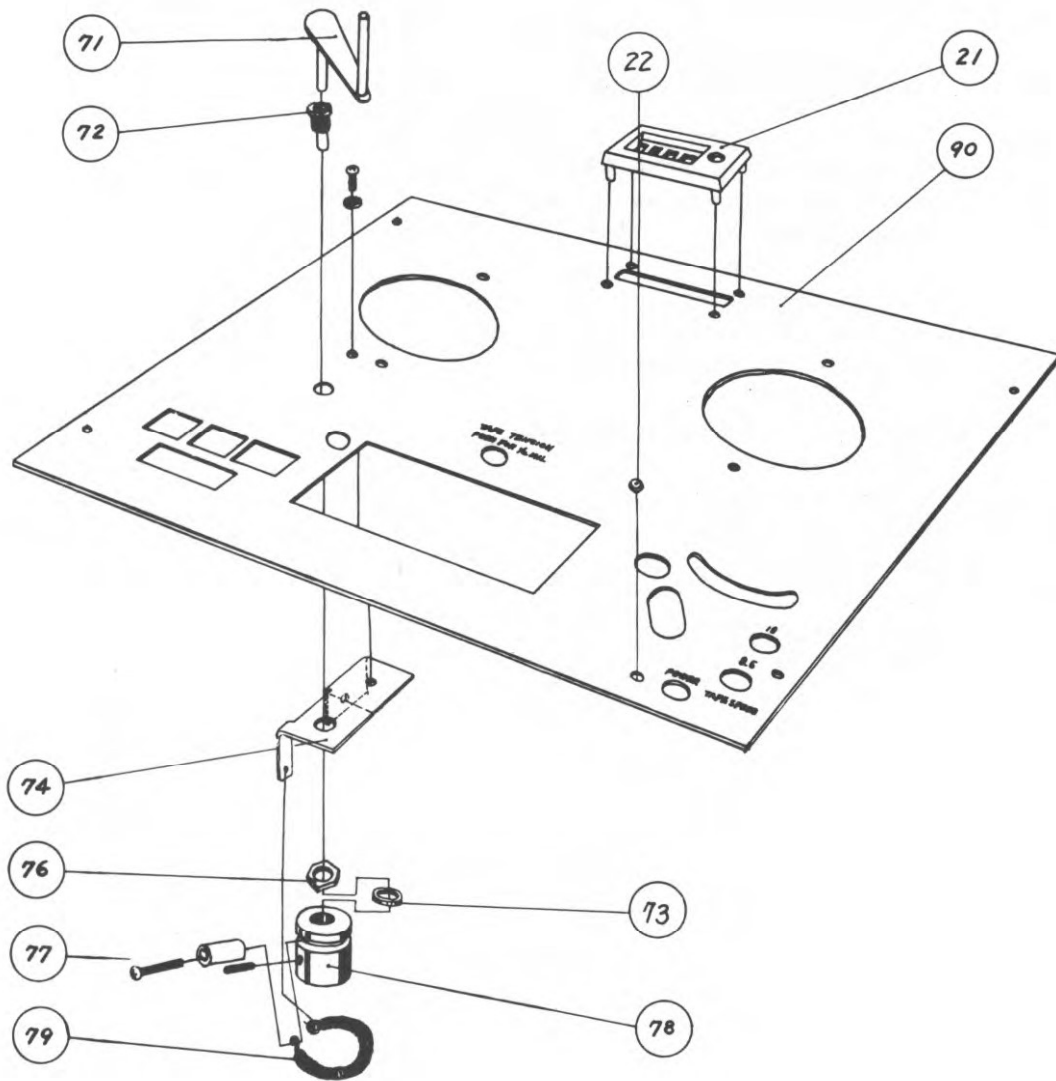

A-4000S FACE PLATE ASS'Y, EXPLODED VIEW

BRAKE ASS'Y

REF. NO.	PART NO.	DESCRIPTION	1st Revision	2nd Revision	3rd Revision
35	17001	Brake Band Ass'y			
36	17191	Brake Band			
37	17138-2	Brake Felt			
50	17007	Brake Mounting Base Ass'y			
51	17199	Brake Mounting Base	17200		
52	17201-1	Brake Lever A			
53	17202-1	" B			
54	17190	Left Brake Spring			
55	17189	Right Brake Spring			
56	17180	Brake Band Retainer			
57		Vinyl Pipe			
38	17203	Micro-switch Retaining Plate			
39	27179	Insulation Plate			
42	44613	Micro-switch			
45	54102	Capacitor 0.1MF			
58	61621-1	Solenoid Ass'y			
59	12155	Pin A			
813		Flat Washer M3			
751		Pin M1			

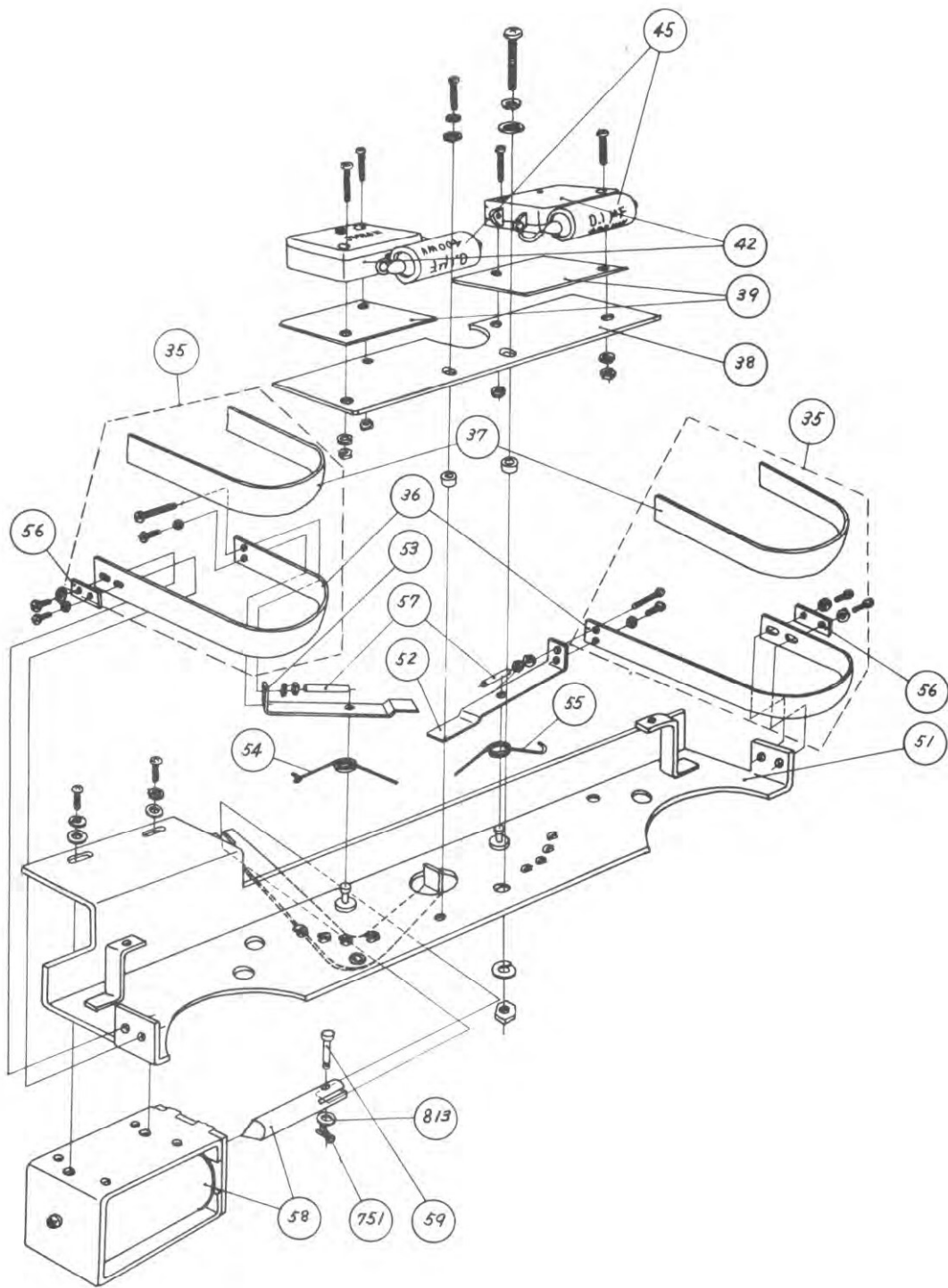

A-4000S BRAKE ASS'Y, EXPLODED VIEW

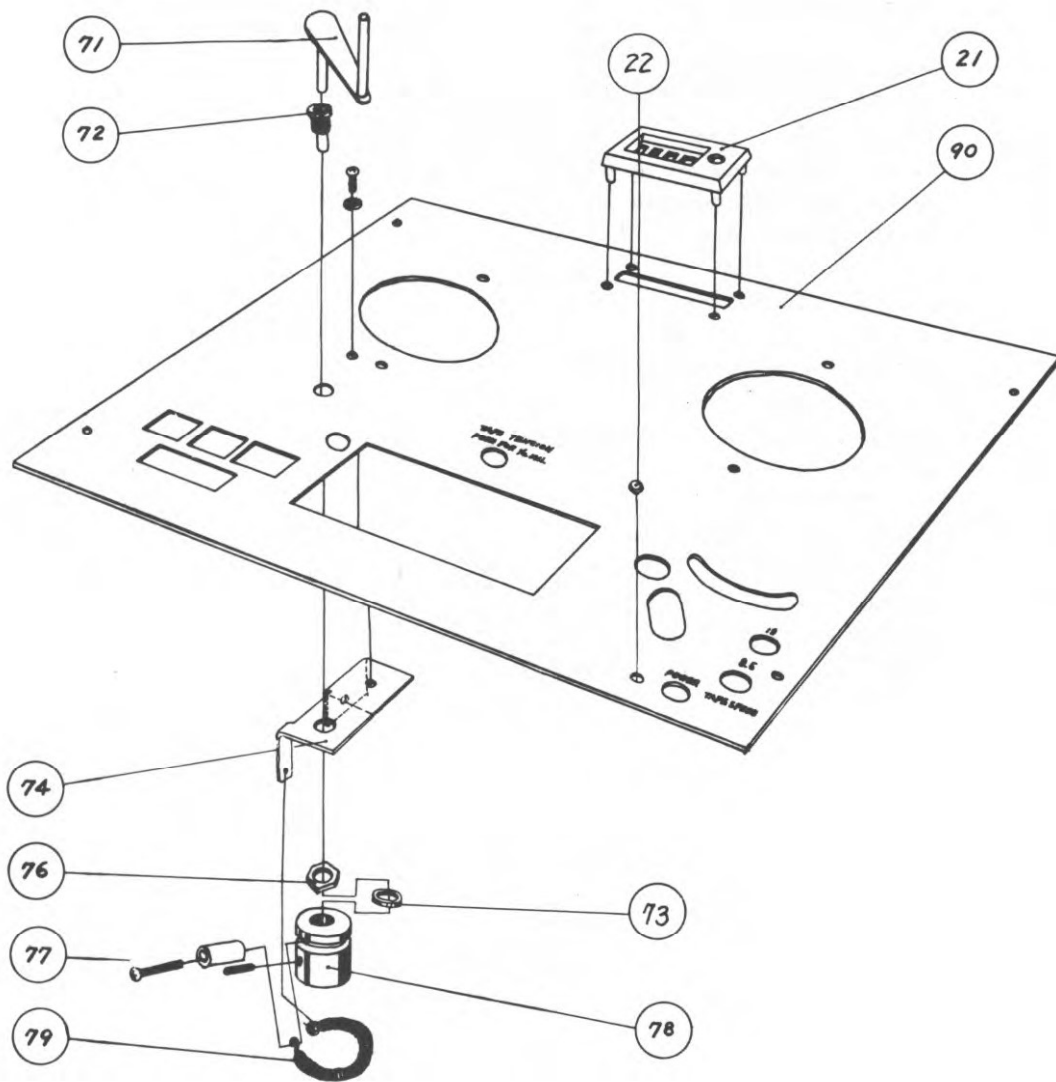

A-4000S FACE PLATE ASS'Y, EXPLODED VIEW

RA-40S AMPLIFIER

REF. NO.	PART NO.	DESCRIPTION	1st Revision	2nd Revision	3rd Revision
900		RA-40S Record Amplifier			
901	58114	Volume Indicator Meter			
902	23163	Face Plate			
903	41424	Record Indicator Plate			
906		Resistor 3.6 k Ω 1/4W Carbon			
907	23168	Chassis			
908	43010	Jack			
909	53706	Double Potentiometer 10 k Ω Carbon			
911	56603	Choke Coil			
913	41425	Rec Lamp			
914	44608	Micro-switch			
915					
916	44407	Monitor Selector Switch			
917	43418	Jack			
918	41425	Micro-switch Retainer			
921	27289	PCB Retainer A			
		" B			
924	48814	Record Printed Board Ass'y			
927	56128	Power Transformer			
928	55511	Capacitor 1000 MF 35V Electrolytic			
929	52212	Resistor 130 Ω 10 W			
930	52424	Resistor 150 Ω 10 W			
931	43415	Socket 7P			
932	43001	DIN Connector			
933	43234	11P Plug			
934	41207	Fuse Post			
935	41101	Puse 1A			
936	43444	Pin Jack			
937	51370	Resistor 100k Ω 1/4W			
938	45206	Terminal Strip 1L-2P			
939					
941	48047-1	OSC Printed Board			
942	56307	OSC Coil			
943	27292	" Retainer			
944	24063	" Leg			
945	27291	" Felt			
940	48815	Oscillator Ass'y			
946	23174-1	OSC Transistor Heat Sink			
947	23186	Sash			
948	26091	Back Dress Panel			
950	52223	Knob (Inner)			
951	25218	" (Outer)			
952	23166-1	Record Button Protector			
954	23167	Clip			
949		M3 Screw			
		Transistor 2SB257			
		" 2SB189			
		" 2SB94			
		" 2SB415			
		" 2SD24			
		" 2SB440			
		" 2SA49			
955	27262	Plastic Washer B			
956	27261	" A			
957	27056	Fiber Washer			

HEAD ASS'Y

REF. NO.	PART NO.	DESCRIPTION	1st Revision	2nd Revision	3rd Revision
100	13014	Head Ass'y			
101	66604-1	Record Head			
102	66903-1	Playback Head			
103	66303-1	Erase Head			
104	13362	Head Base Plate			
105	13363	Bottom Shield Plate			
106	13359	Head Mounting Plate A			
107	13360	" " B			
108	13358	" " D			
109	22020	Spring			
110	22028	"			
111	22042	"			
112	13334	Tape Guide			
114	24039	Leg			
117	13333	Housing Leg			
118	48031	Printed Terminal Strip 15P			

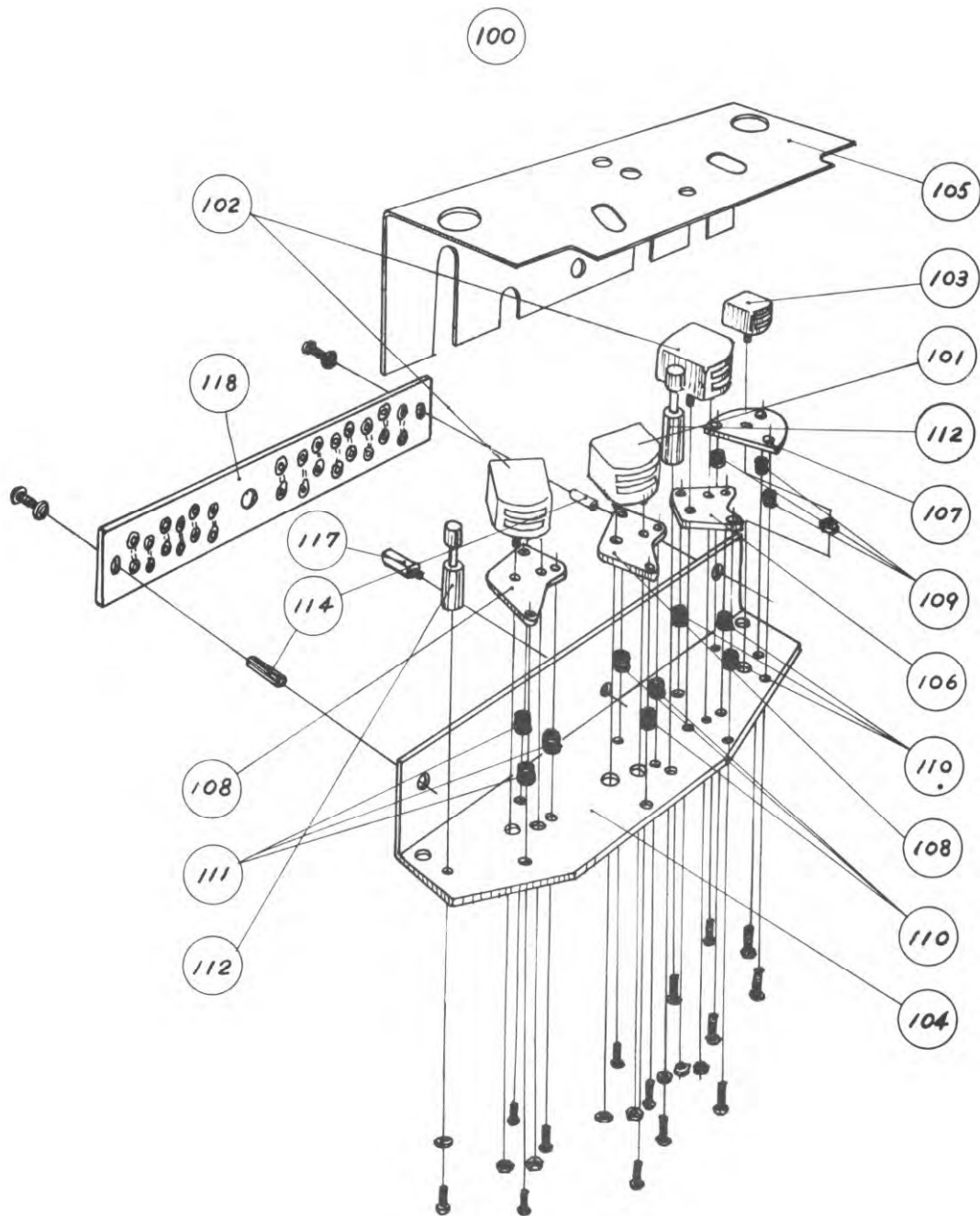

A-4000S HEAD ASS'Y, EXPLODED VIEW

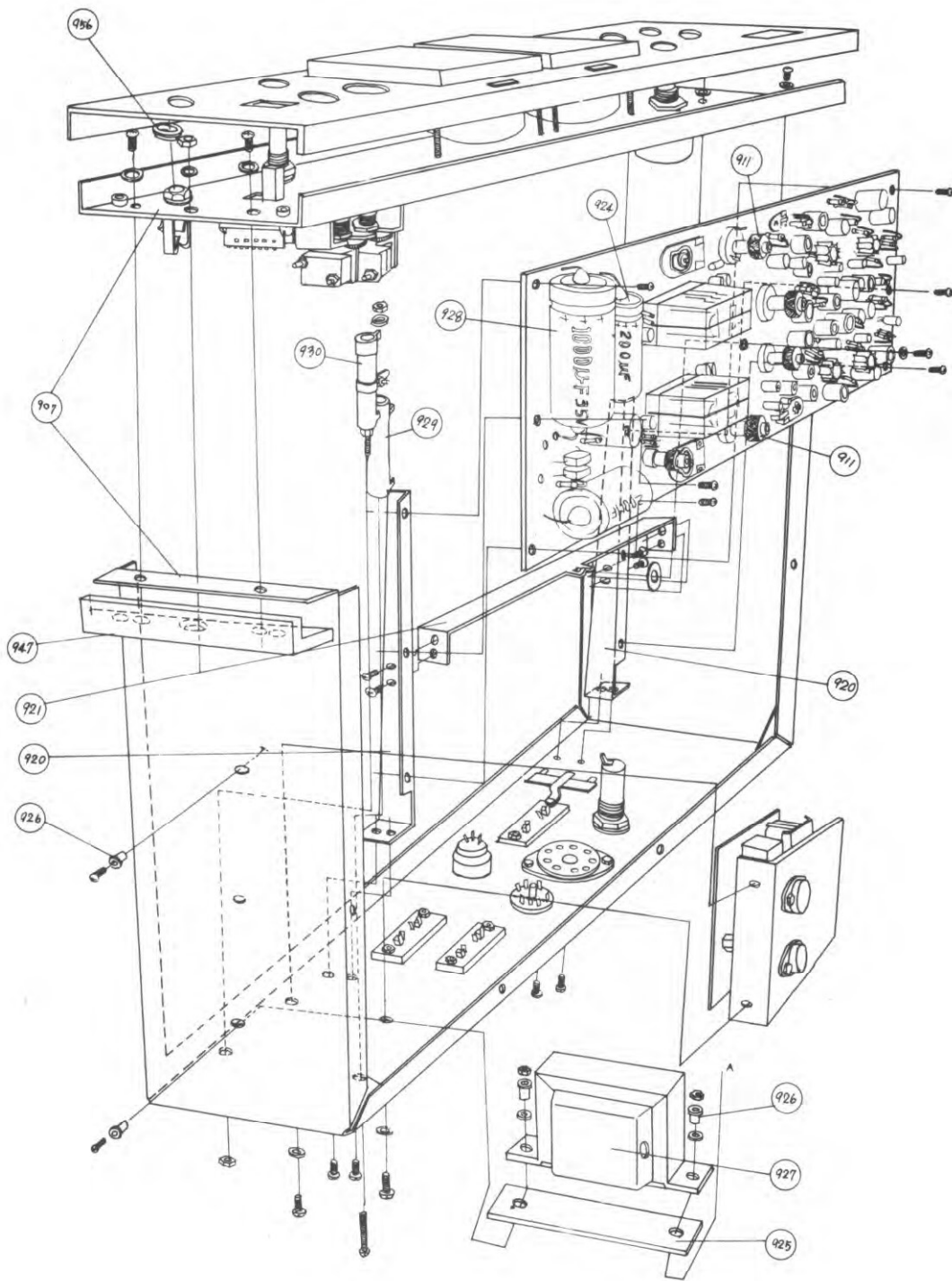

RA-40S AMPLIFIER, EXPLODED VIEW

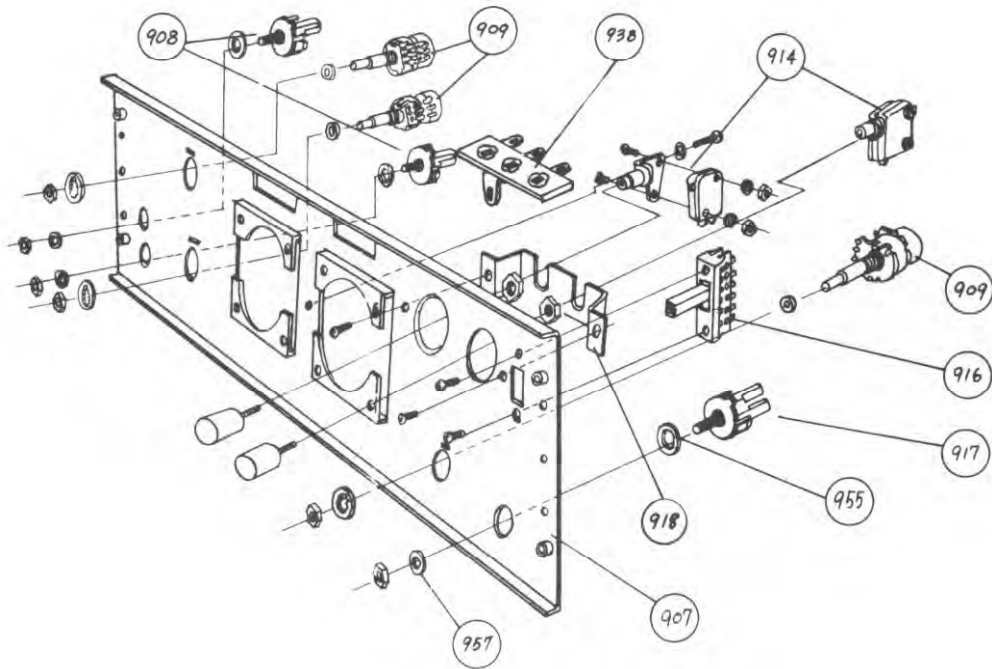

RA-40S FACE PLATE ASS'Y, EXPLODED VIEW

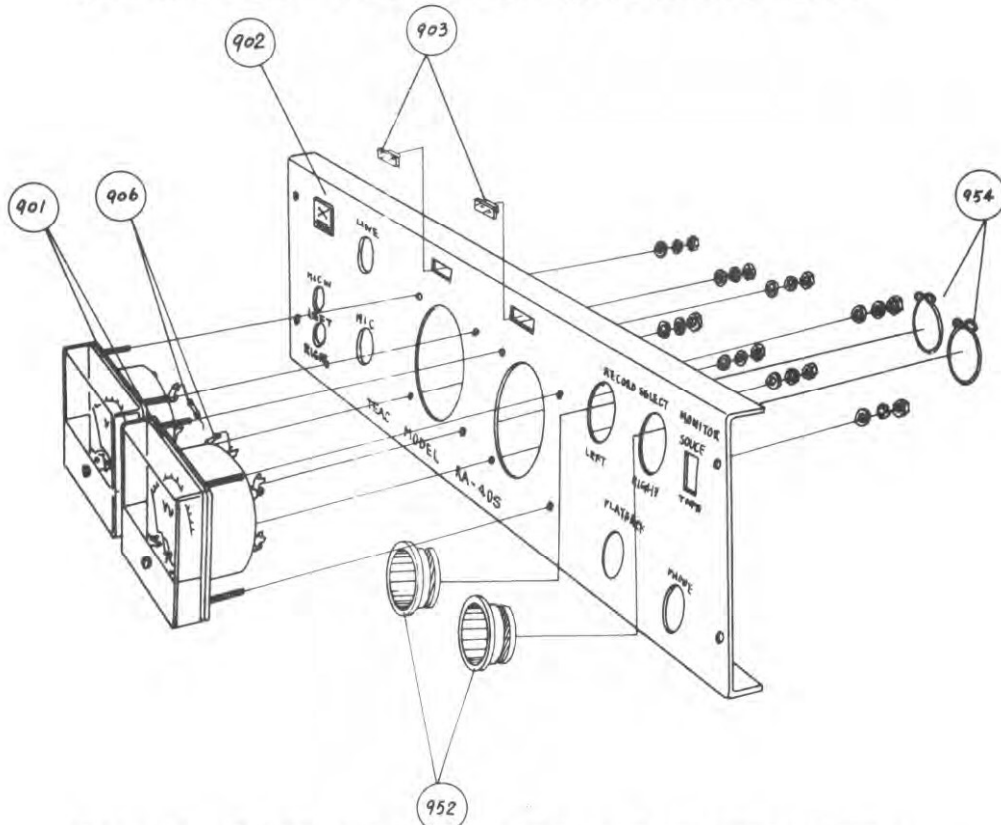

RA-40S FACE CHASSIS ASS'Y, EXPLODED VIEW

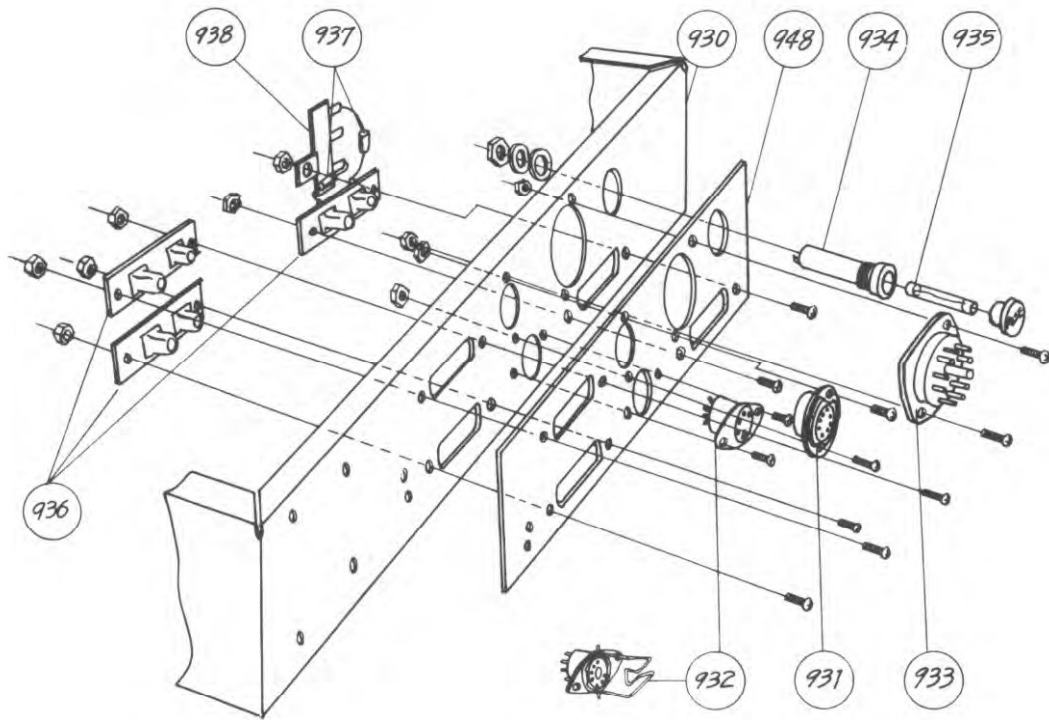

RA-40S BACK CHASSIS ASS'Y, EXPLODED VIEW

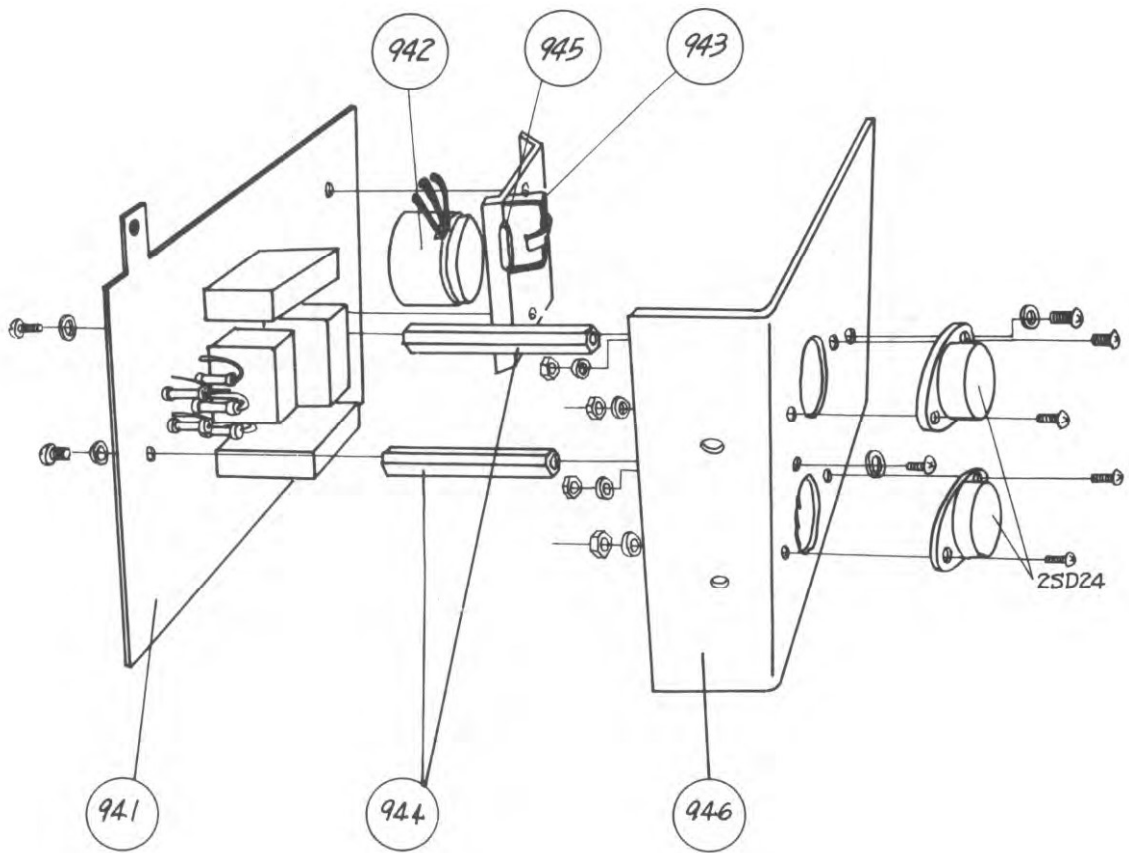

RA-40S BIAS OSCILLATOR CIRCUIT BOARD

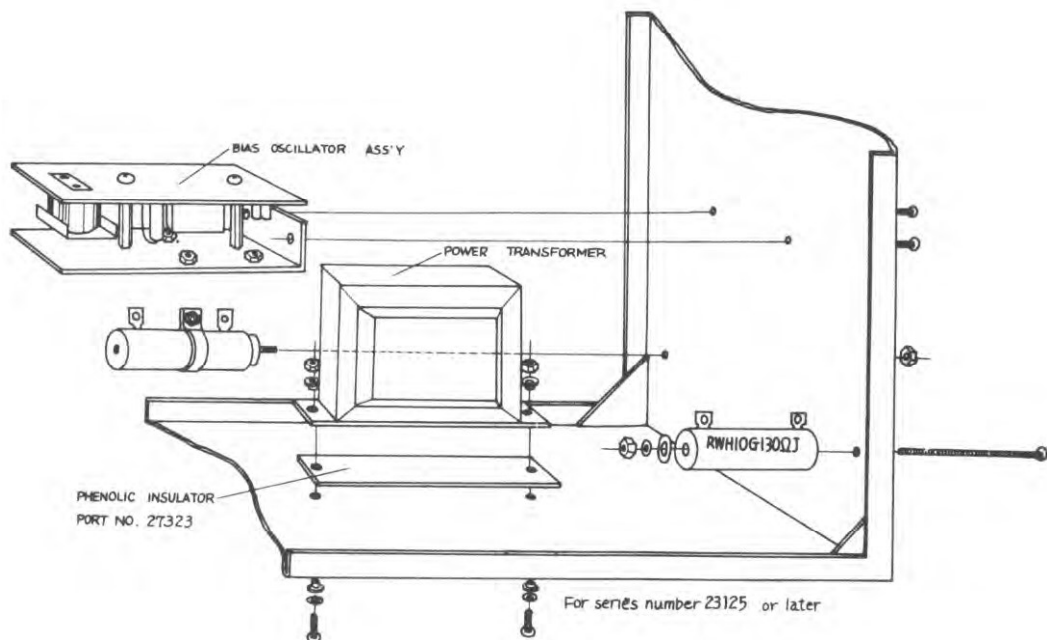
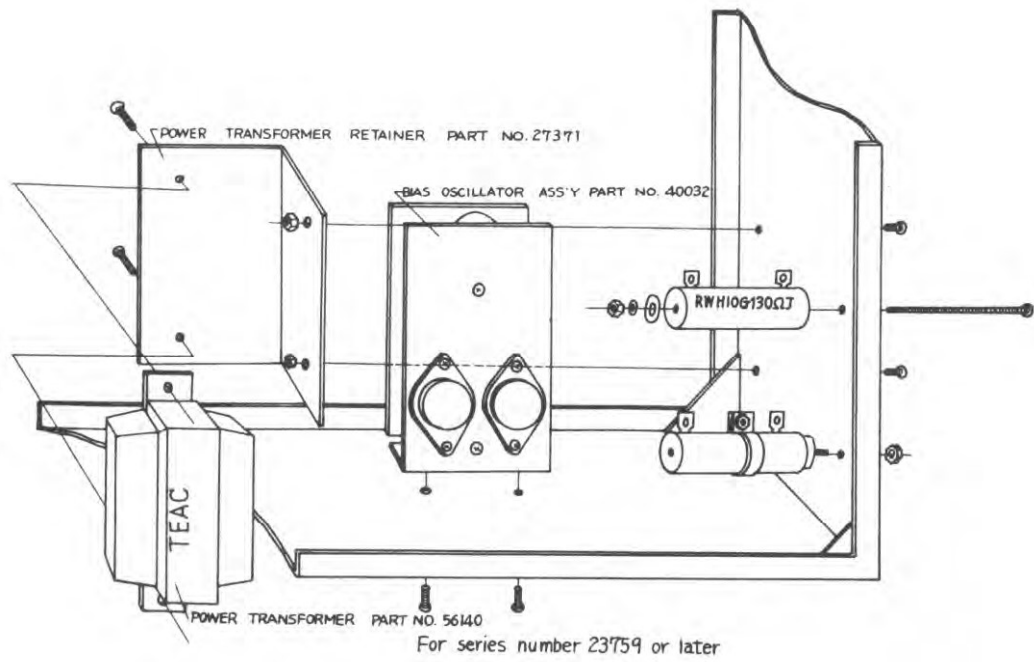

RA-40S RIGHT CHASSIS ASS'Y, EXPLODED VIEW

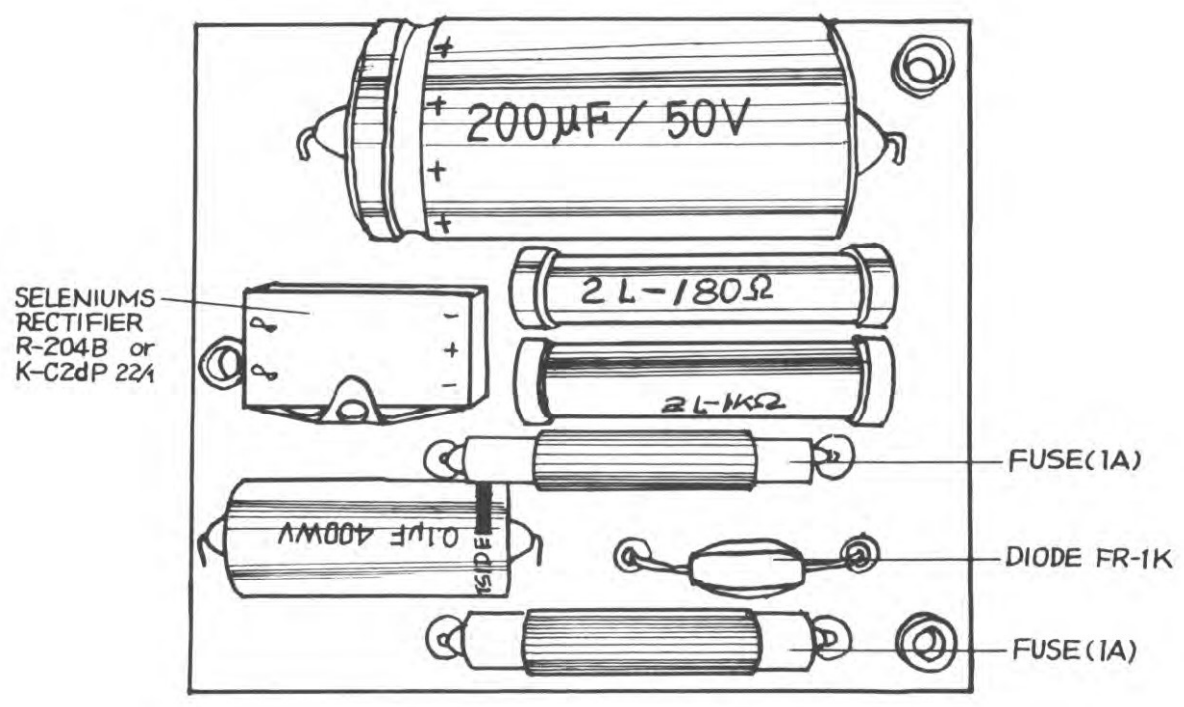
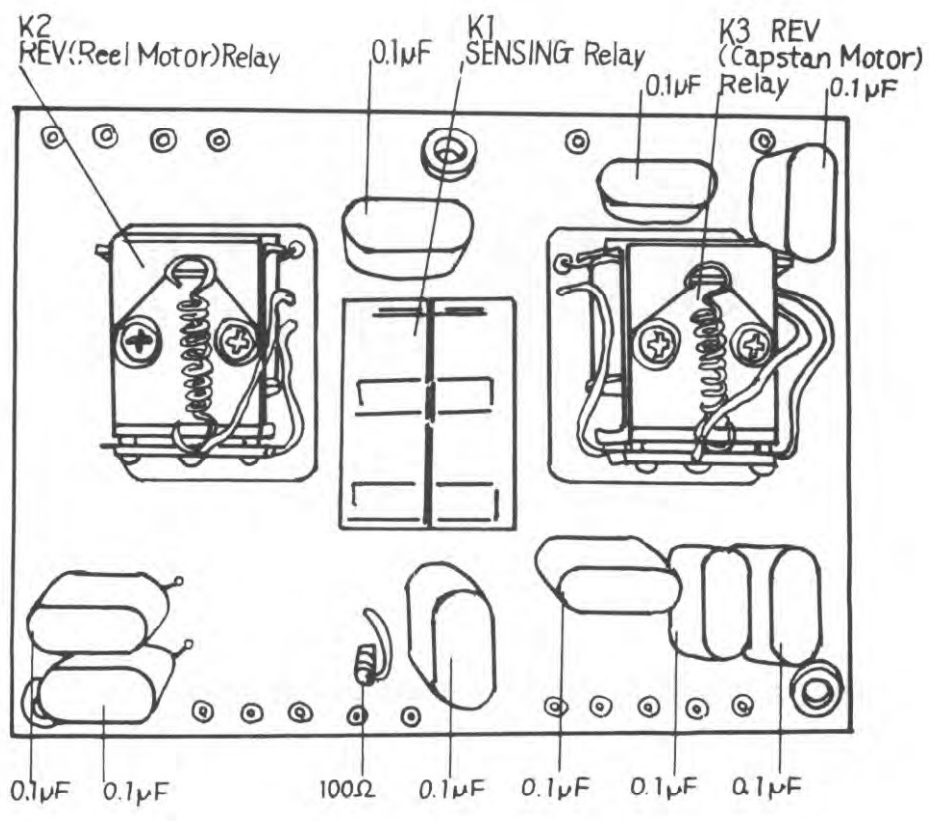

A-4000S POWER SUPPLY CIRCUIT BOARD

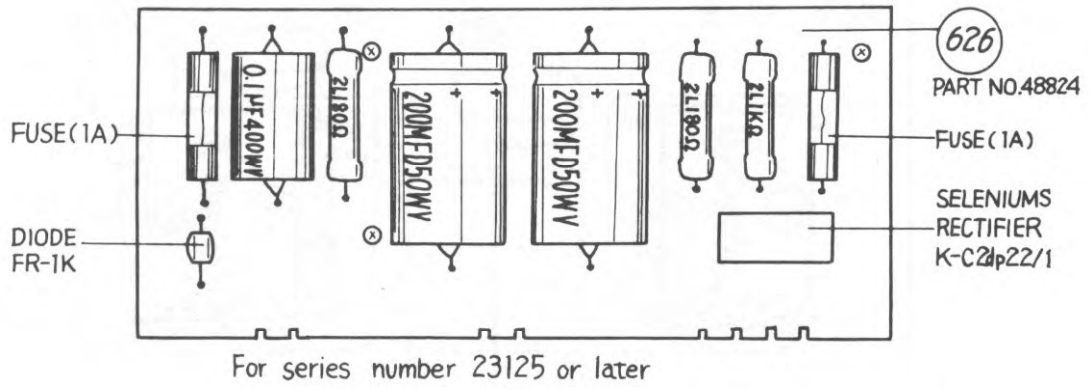

A-4000S POWER SUPPLY CIRCUIT BOARD

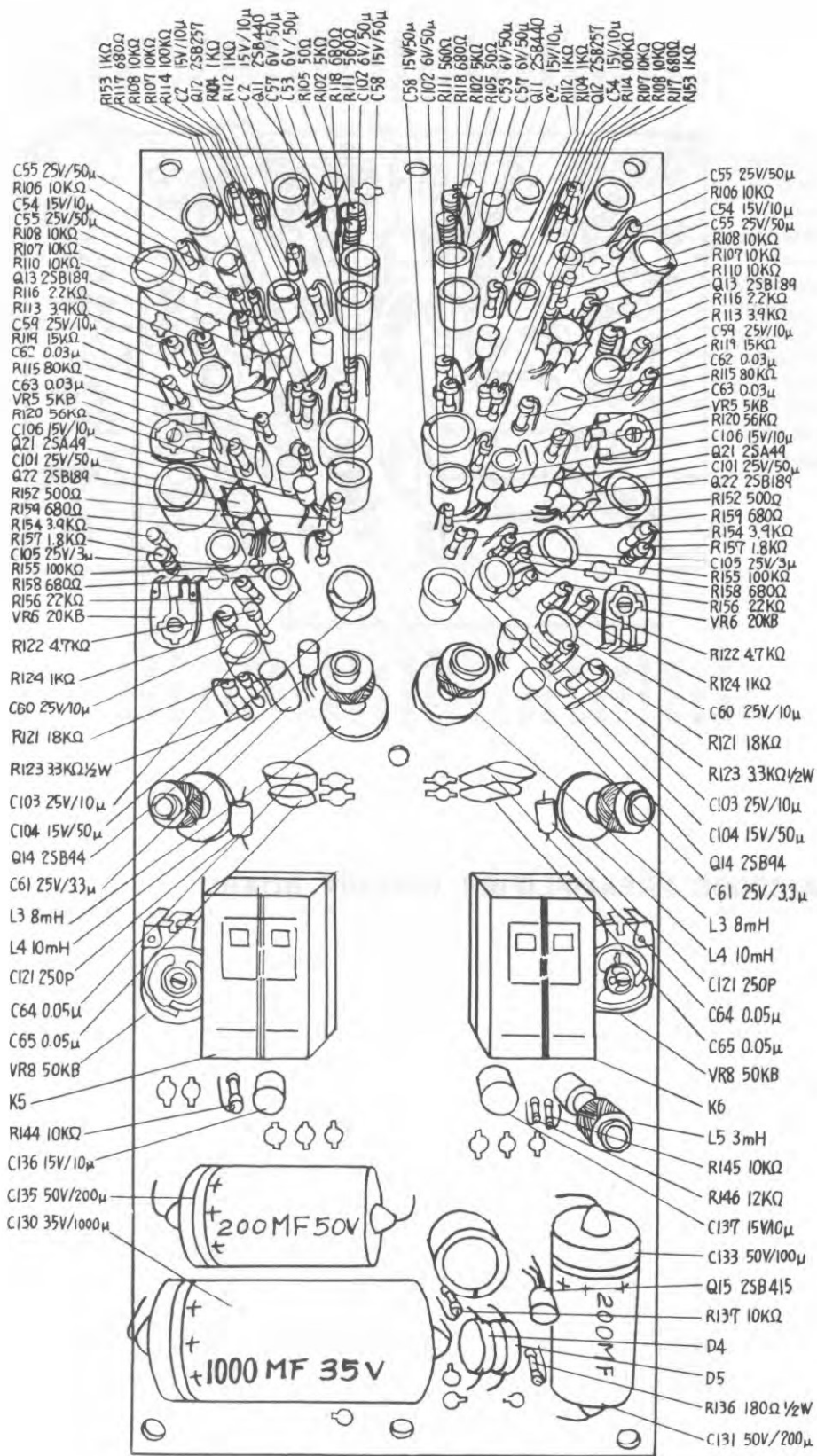

RA-40S RECORD AMPLIFIER CIRCUIT BOARD

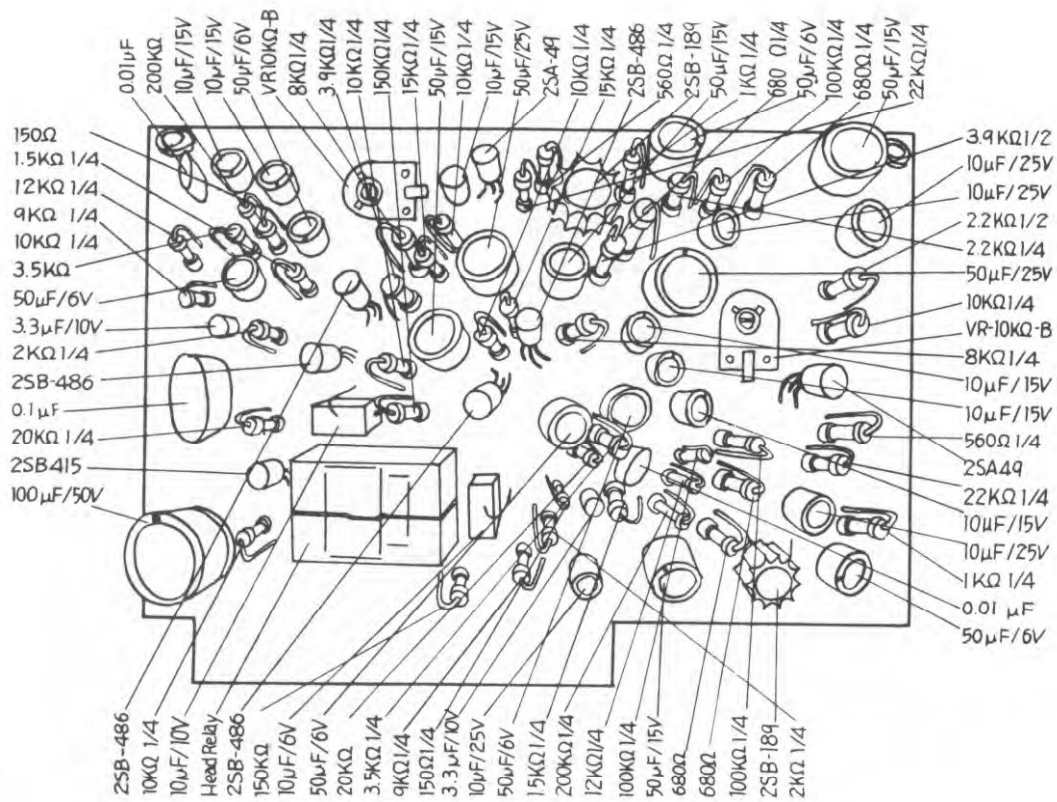

A-4000S PREAMPLIFIER CIRCUIT BOARD