

TEAC

SERVICE MANUAL

A-650

Stereo Cassette Deck with Dolby System

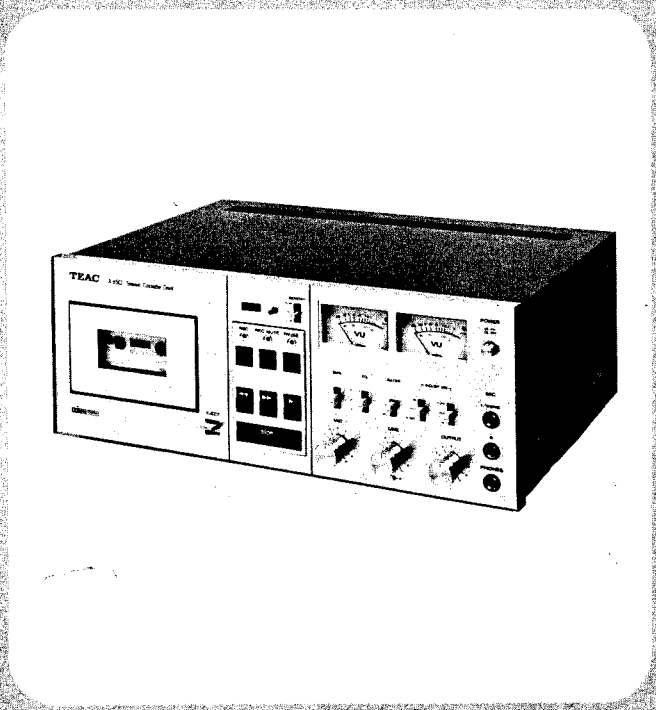

GENERAL INTRODUCTION

This Service Manual is designed to provide up-to-date information to assist the skilled service technician to properly repair, adjust and maintain the TEAC A-650 Stereo Cassette Tape Deck.

The A-650 is a high quality deck designed to be used as an indispensable part of a superior home stereo system. It contains a 2-motor transport utilizing a DC reel motor and a Phase Locked Loop (PLL) servo motor, push button control panel, Memory Counter with Play feature, Record Mute feature, advanced Dolby NR circuitry, Peak indicators, Limiter, 3-position BIAS and EQ selector Switches, as well as many of the standard TEAC features.

If any of the adjustments or repairs seem too complicated or are difficult for you to accomplish, please contact the nearest TEAC Factory Service Department or write directly to a TEAC office, the addresses of which are printed on the back cover.

NOTE

When ordering replacement parts, please refer to the PARTS LIST which is printed separately from this manual.

* Noise reduction circuit made under license from Dolby Laboratories Inc. The word "Dolby" and the Double-D symbol are trademarks of Dolby Laboratories Inc.

TABLE OF CONTENTS

1.	Test Equipment Required	3		6-2.	Playback Performance	21
2.	Specifications & Service Data	4		6-2-1.	Record/Playback Head Azimuth Adjustments	21
3.	Parts Location	6		6-2-2.	Specified Output Level Setting	22
4.	Partial Disassembly of Main Parts	7		6-2-3.	Frequency Response -Playback-	22
4-1.	Case/Front Panel	7		6-2-4.	Signal to Noise Ratio -Playback-	23
4-2.	Tape Transport Chassis Removal	7		6-2-5.	VU Meter Calibration -Playback-	23
4-3.	Partial Rotation of Front Chassis	7		6-2-6.	Headphone Output Level Checks	23
4-4.	Head	8		6-3.	Monitor Performance	24
4-5.	Pinch Roller	8		6-3-1.	Minimum Input Level Checks	24
4-6.	Cassette Holder	8		6-3-2.	Specified LINE Control Setting	24
4-7.	Capstan Motor	9		6-3-3.	VU Meter Calibration -Record-	24
4-8.	Capstan Drive Ass'y/Drive Belt	9		6-3-4.	LED Peak Level Indicator Calibration	24
4-9.	Reel Motor	10		6-3-5.	DOLBY NR COPY-OUT-FM Switch Function Check	25
4-10.	Brake Plate Ass'y	10		6-4.	Recording Performance	25
4-11.	Reel Tables	11		6-4-1.	Bias Trap Adjustments	25
4-12.	Idler Ass'y	11		6-4-2.	Record Bias Setting	26
5.	Mechanical Checks and Adjustments	12		6-4-3.	Record Level Setting	27
5-1.	Take-up Torque	12		6-4-4.	Distortion Checks	27
5-2.	Fast Forward & Rewind Torque	12		6-4-5.	Frequency Response -Overall-	28
5-3.	Pinch Roller Pressure	13		6-4-6.	Signal to Noise Ratio - Overall-	28
5-4.	Brake Tension	13		6-4-7.	Dolby NR Effect Measurement	29
5-5.	Tape Speed/Wow and Flutter	14		6-4-8.	Peak Limiter Efficiency Checks	29
5-5-1.	Tape Speed	14		6-4-9.	Erase Efficiency	30
5-5-2.	Wow and Flutter	14		6-4-10.	Channel Separation	31
5-6.	Flywheel Bearing Adjustment	15		6-4-11.	Adjacent Track Crosstalk Measurement	32
5-7.	CASSETTE IN Switch Position Adjustment	16		7.	Block Diagram	33
5-8.	RECORD SAFETY Switch Position Adjustment	16		8.	Level Diagram	34
5-9.	Cassette Holder Motion Checks	16		9.	Trouble-Shooting	35
5-10.	Oil Retaining Washer Clearance Check	16		TEAC Test Tape	5	
5-11.	Eject Lock Lever Adjustment	17		Lubrication	11	
5-12.	Pushbutton Control Checks	18		Torque Measurement using the Cassette Torque Meter	13	
5-13.	Auto-End Stop Facility Check	19		Visual Index (for 5-6, 7, 8, 11 Sections)	15	
5-14.	Memory Device Function Checks	19		Voltage and Frequency Setting	17	
6.	Electrical Checks and Adjustments	19				
6-1.	Adjustment Location	20				

1. TEST EQUIPMENT REQUIRED

1. **Spring scale:** For take-up torque check: 0 – 70 g (0 – 2.5 oz.)
For fast forward & rewind torque checks: 0 – 200 g (0 – 7.0 oz.)
2. **String:** Length: about 50 cm (20")
3. **Cassette Reel Adapter:** Diameter: 22 mm
* The tools above (1 – 3) are constructed as shown in Fig. 1-1.
4. **Cassette Torque Meter:** For take-up torque check: 0 – 100 g·cm (0 – 1.4 oz·inch)
For fast forward & rewind torque checks: 0 – 160 g·cm (0 – 2.2 oz·inch)
* Use of the Cassette Torque Meter instead of the spring scale, if you have one, is recommended for easier measuring. (See Fig. 5-3 on page 13.)
* When ordering Cassette Torque Meter, allow for longer delivery time that is required for it.
5. **Spring scale:** For Pinch Roller pressure check: 0 – 1 kg (2.2 lbs)
6. **Wow/flutter meter:** MEGURO DENPA SOKKI K.K., Model MK-668A or D & R Co., Model FL-4B.
7. **Frequency counter:** Digital type, capable of 10 Hz to 100 kHz indication.
8. **AF oscillator:** 10 Hz – 100 kHz
9. **AC VTVM:** 0.1 mV – 300 V
10. **Attenuator:** General Purpose
11. **Distortion analyzer:** Basic frequency 400 Hz/1 kHz
12. **Oscilloscope:** General Purpose
13. **Band-pass filter:** 1 kHz narrow band-pass type
14. **Test load resistor:** Non inductive type 8 ohm/1 W
15. **Plastic alignment tool:**
16. **Head demagnetizer:** TEAC E-3 or equivalent
17. **Cleaner:** TEAC TZ-261 Tape Recorder Cleaner kit or pure alcohol
18. **Oil:** TEAC TZ-255 Oil kit or equivalent

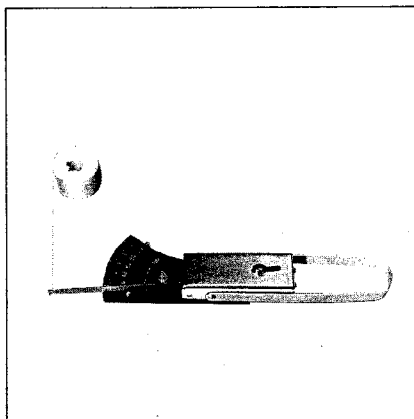

Fig. 1-1 Spring Scale & Cassette Reel Adapter

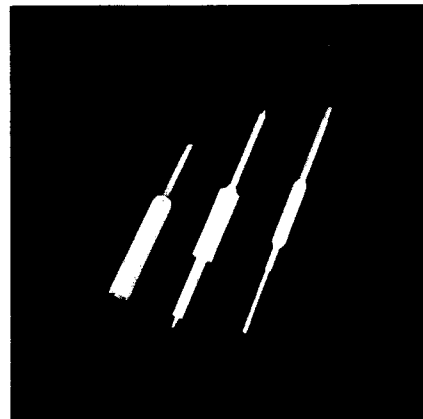

Fig. 1-2 Plastic Alignment Tool

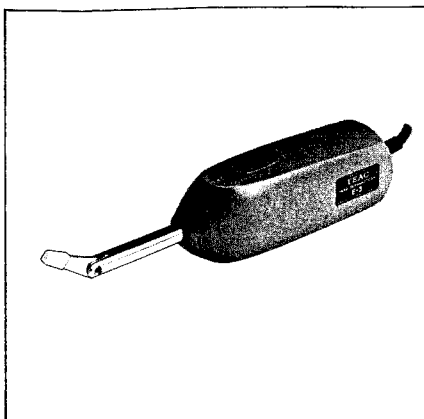

Fig. 1-3 E-3 Head Demagnetizer



Fig. 1-4 TZ-261 Tape Recorder Cleaner Kit

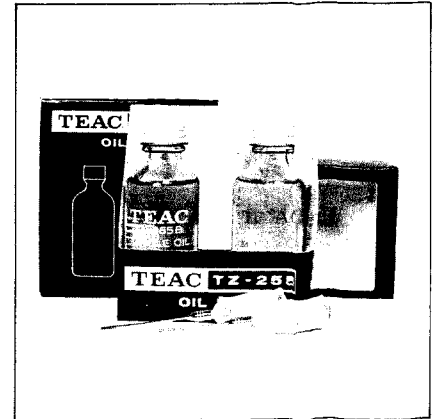

Fig. 1-5 TZ-255 Oil Kit

2. SPECIFICATIONS & SERVICE DATA

SPECIFICATIONS

Track System	4-track, 2-channel stereo
2 Heads	Erase and Record/Playback
Type of Tape	Cassette tape, C-60 and C-90 (Philips type)
Tape Speed	4.8 cm/s (1-7/8 ips)
Inputs (level and impedance)	Microphones: Min. input level: -67 dB (345 μ V)/(10 kohms or more) Line: Specified input level: -9 dB (274 mV)/(50 kohms) Min. input level: -19 dB (86 mV) DIN*: Min. input level: -35 dB (13.7 mV) DOLBY FM/COPY: FM: -17 dB (109 mV) COPY: -9 dB (274 mV)
Outputs (level and impedance)	Line out: Max. output level: +1 dB (0.869 V)/(into 50 kohms) Specified output level: -5 dB (435 mV) Headphones: Specified output level: -15.7 dB (130 mV)/(8 ohms)
Equalization	EQ 1: 3180 μ s + 70 μ s (for CrO ₂ tape) EQ 2: 3180 μ s + 70 μ s (for FeCr tape) EQ 3: 3180 μ s + 120 μ s (for regular Hi-Fi tape)
Head Configuration	1/2-track, 1-channel Erase Head 1/4-track, 2-channel Record/Playback Head
2 Motors	1 Phase Locked Loop Servo Controlled DC Capstan Motor 1 Mechanical Governed DC Reel Motor
Bias Frequency	100 kHz
Operating Position	Horizontal
Power Requirement	100/117/220/240 V AC, 50/60 Hz (General Export Models) 117 V AC, 60 Hz (USA/Canada Models) 220/240 V AC, 50 Hz (Europe Model) 240 V AC, 50 Hz (Australia Model)
Power Consumption	35W
Weight	13 kg (28 $\frac{3}{4}$ lbs.) net

* Pursuant to DIN Standards

TEAC TEST TAPE

REMARKS: 0 dB = DIN Reference level (333 Hz)

For tape speed & wow/flutter test

- MTT-111: • For Playback method
• 3,000 Hz/-10 dB
- MTT-502: • For Record/Playback method (blank tape)

For record performance alignment (blank tape)

- MTT-505B or similar: For BIAS 1/EQ 1 (CrO₂)
- MTT-504 or similar: For BIAS 2/EQ 2 (Fe-Cr)
- MTT-501 or similar: For BIAS 3/EQ 3 (Low Noise, High Output tape)

For playback performance alignment

- MTT-150: • For Dolby level calibration
• Dolby B-type tone (400 Hz tone),
200 nWb/m
- MTT-116K: • For frequency response test for EQ 1 &
2 (CrO₂ & Fe-Cr)
• 3180 μ s + 70 μ s
• 315 Hz/-4 dB, 31.5 Hz ~ 14 kHz/-24 dB
- MTT-116U: • For frequency response test for EQ 3
(Hi-Fi tape)
• 3180 μ s + 120 μ s
• 315 Hz/-4 dB, 31.5 Hz ~ 14 kHz/-24 dB

NOTE: The TEAC test tapes require longer delivery time than regular parts.



Fig. 2-1 TEAC Test Tape

SERVICE DATA

Mechanical

Tape Speed Deviation	3,000 Hz \pm 30 Hz
Tape Speed Drift	15 Hz
Wow and Flutter	Playback: 0.07% (WRMS) 0.15% (RMS)
	Record/Playback: 0.18% (WRMS)
Pinch Roller Pressure	400 g \pm 20 g (13.5 ~ 15.0 oz)
Reel Torque	Take Up: 40 ~ 70 g·cm (0.6 ~ 1.0 oz·inch) Fast Forward: 100 ~ 150 g·cm (1.4 ~ 2.1 oz·inch) Rewind: 100 ~ 150 g·cm (1.4 ~ 2.1 oz·inch)
Fast Winding Time	90 seconds for C-60
End-stop Activate Time	1.5 seconds \pm 0.5 seconds

Electrical

Frequency Response	Refer to frequency response limits charts on page 22 and 28
Signal to Noise Ratio	Playback method: CrO ₂ & Fe-Cr tapes: 48 dB (minimum) Hi-Fi tape: 46 dB (minimum)
	Record/Playback method: CrO ₂ & Fe-Cr tapes: 46 dB (minimum) Hi-Fi tape: 44 dB (minimum)
	With Dolby Noise Reduction used for recording and playback, S/N ratio is improved by 5 dB at 1 kHz and 10 dB at frequencies over 5 kHz.
Erase Efficiency	65 dB minimum
Channel Separation	30 dB minimum (at 1 kHz)
Crosstalk Between Adjacent Tracks	40 dB minimum (at 125 Hz)
Total Harmonic Distortion	BIAS/EQ 1: 2.5% (maximum) BIAS/EQ 2: 2.5% (maximum) BIAS/EQ 3: 2.5% (maximum)

- NOTE:**
- Improvements may result in Specifications and Service Data changes.
 - Value of "dB" in the Data refers to 0 dB = 0.775V, except where specified. If a Test Set or VTVM calibrated to 0 dB = 1V is to be used, appropriate compensation should be made.

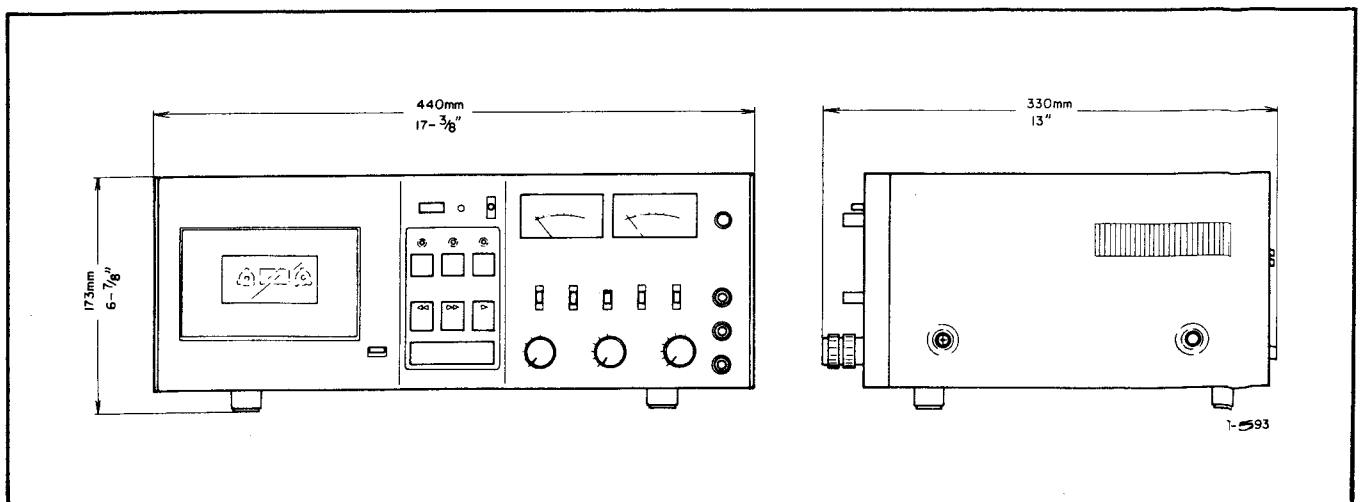

Fig. 2-2 A-650 Dimensions

3. PARTS LOCATION

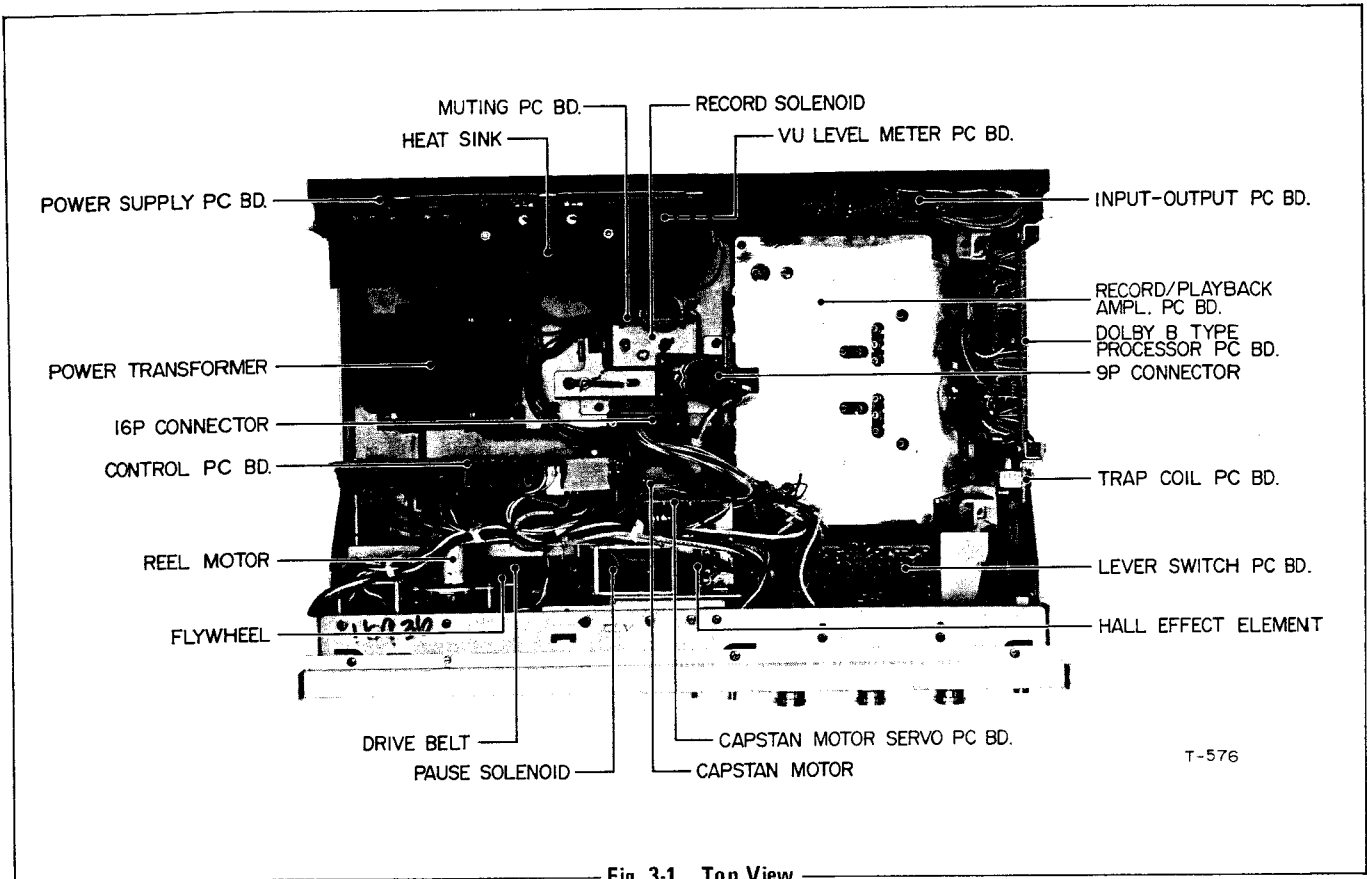

Fig. 3-1 Top View

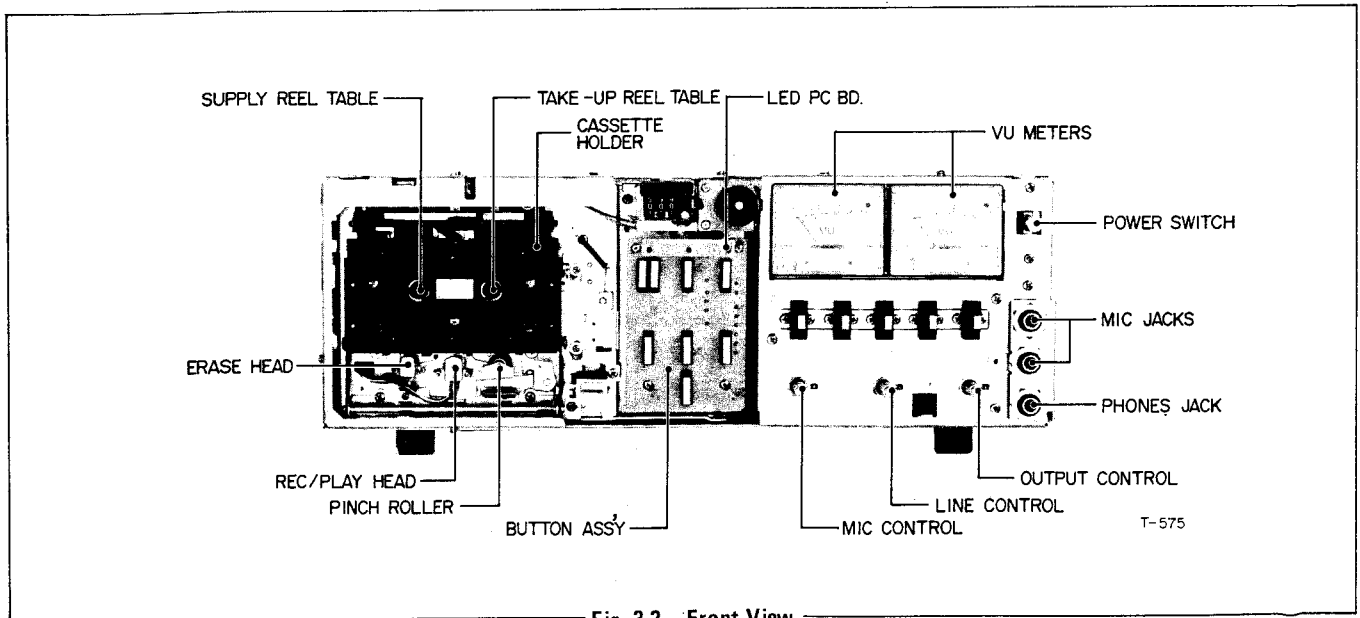

Fig. 3-2 Front View

4. PARTIAL DISASSEMBLY OF MAIN PARTS

NOTE

1. Use the proper tools. Demagnetize the tools before use.
2. When mounting or removing a spring, pay heed to the position (direction) of the anchor or hook. The wrong position may result in a change in the tension.
3. When reassembling, don't forget to reinstall all hardware such as springs and washers, etc.
4. For assembling hardware shape identification, see ASSEMBLING HARDWARE CODING LIST in the Parts List.

4-1. CASE/FRONT PANEL

NOTE

When removing or installing the Front Panel, center the levers of the toggle switches on the Front Panel to make the work easier.

Remove the parts in the following sequence.

1. Top Cabinet Ass'y (D)
2. Cassette Holder Cover Ass'y (A)
 - a. Depress EJECT lever.
 - b. Move the latch arm protruding from the top of the Cassette Holder Door to the left to release the Cover.
 - c. Allow the Cover to rotate outward on its hinge; then lift up gently on the Cover to remove it from the Door.
3. Knobs (C)
4. Front Panel Ass'y (B)

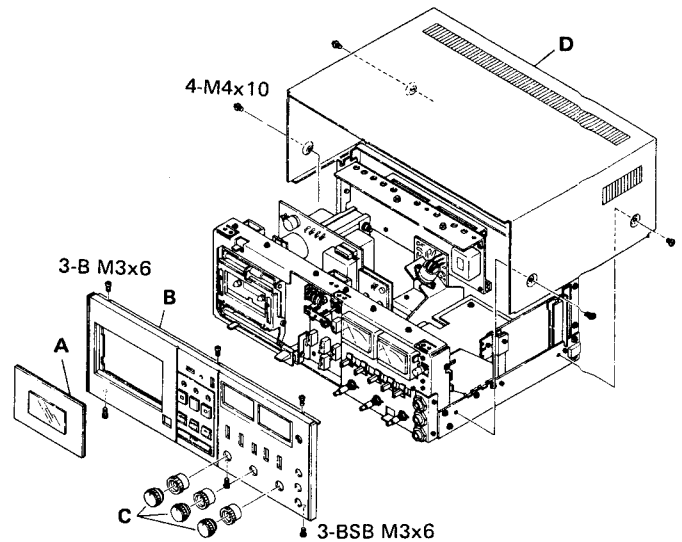

Fig. 4-1 Case/Front Panel Removal

4-2. TAPE TRANSPORT CHASSIS REMOVAL

First do procedure in section 4-1.

1. Disconnect the 16P Plug and the 9P plug. See Fig. 3-1 on page 6.
2. Unscrew the screws (B) (H) (C) (F) in that order and loosen (D) to facilitate next step.
3. Tilt the Front Chassis section (E) forward and away from the main chassis (G).
4. Lift the tape transport chassis (A) from the main chassis.

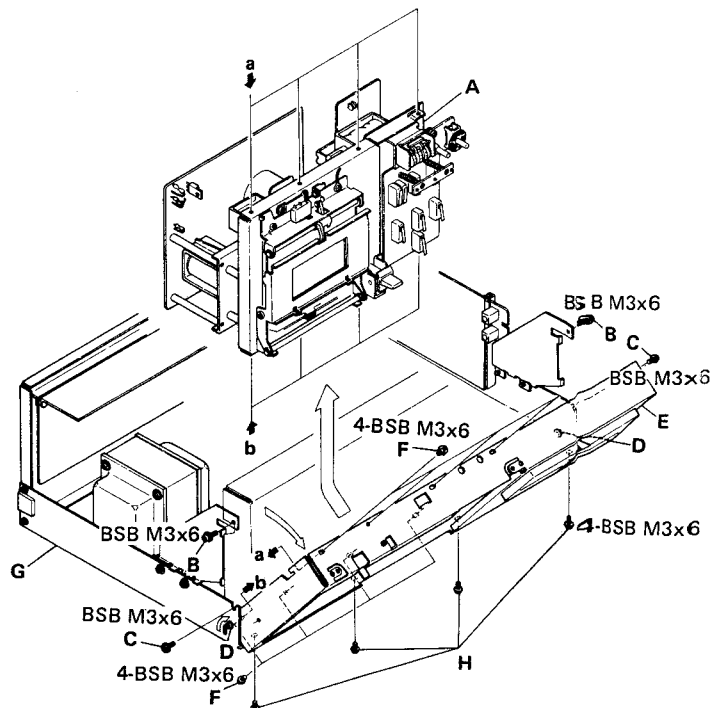

Fig. 4-2 Tape Transport Chassis Removal

4-3. PARTIAL ROTATION OF FRONT CHASSIS

First do procedure in section 4-1.

Most removal and replacement can be made with the Front Chassis section (E) tilted in the forward direction, as explained in the preceding section without removing tape transport chassis (A) which is held in place by screws (F).

4-4. HEAD

First do procedure in section 4-1.

1. Unsolder each lead wire from the terminal pins of the head to facilitate replacement. To re-solder each head wire to the newly replaced head, refer to Fig. 4-4.
2. Lift up the heads after taking off the hardware mounting them.

NOTE

1. After replacing the head, always adjust the head alignment, especially the Record/Playback Head's azimuth (see 6-2-1), and then secure the screws and/or the nut with a drop of locking paint.
2. Connect the wires to the head terminal pins quickly to prevent breaking of internal wires of the head due to overheating.

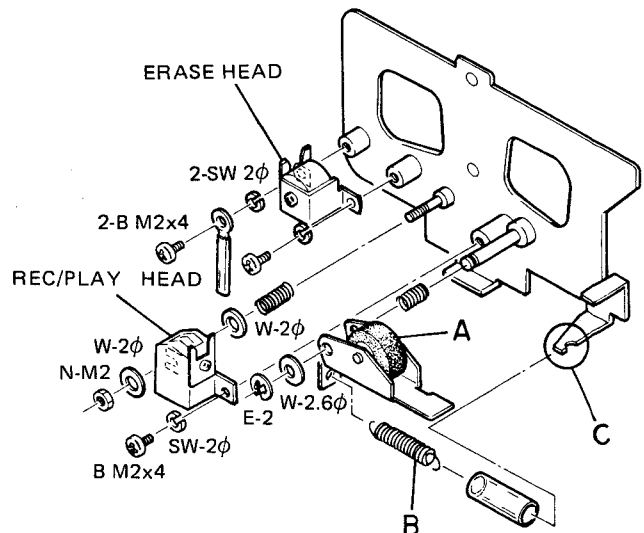

Fig. 4-3 Heads/Pinch Roller Replacement

4-5. PINCH ROLLER

First do procedure in section 4-1.

1. Remove the E-ring retaining the Pinch Roller Ass'y (A) and remove the Spring (B) from the hook (C) of the Head Base Plate and the tab of the Pinch Roller Ass'y.
2. Remove the Pinch Roller Ass'y from the pivot stud pin of the Plate.

NOTE

After replacement, always clean the driving surfaces of the Pinch Roller with the TEAC TZ-261B Rubber Cleaner or with pure alcohol, then proceed directly to the PINCH ROLLER PRESSURE adjustment section. See page 13.

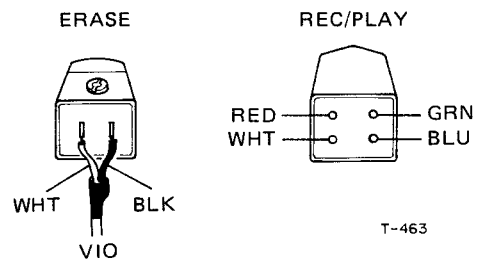

Fig. 4-4 Head Wiring Diagram

4-6. CASSETTE HOLDER

First do procedures in section 4-1 and 4-2.

1. Take off the 2 screws (H) from the transport chassis.
2. Loosen the 2 screw (G) to separate the Cassette Holder Door (F) and the Cassette Holder (E).
3. Detach the Door (F) from the chassis.
4. Remove the Micro Switch Ass'y (B) to simplify the next steps.
5. Take off the E-ring (A) to separate the Cassette Holder (E) from the chassis.
6. Remove the Holder (E).

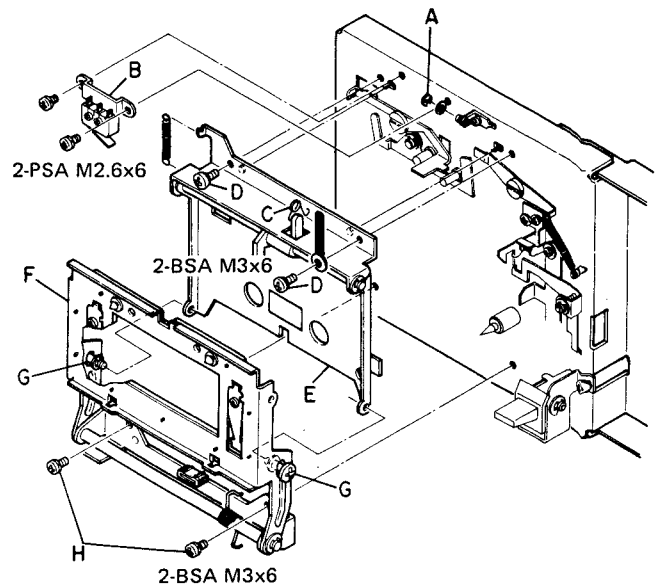

Fig. 4-5 Cassette Holder Removal

4-7. CAPSTAN MOTOR

First remove the Top Cabinet Ass'y (see 4-1), then do section 4-3.

1. Release the Drive Belt from the Motor Pulley.
2. Loosen the two screws holding the P.C. Board insulator, remove the insulator and then unsolder the wires marked with asterisks (*) from the PC Board (part of the Motor Ass'y). Note the color code and the position of each wire prior to unsoldering the leads.
3. Remove the Motor Ass'y together with the PC Board from the chassis by taking off the screws.

NOTE

1. When re-assembling, clean the pulley and the Belt with TEAC TZ-261 Cleaner kit ("A" for the Pulley, "B" for the Belt) or with pure alcohol.
2. Take off or remount the Motor Ass'y taking care not to scratch or otherwise damage the Motor Pulley.
3. When re-attaching the Drive Belt to the Pulley do not twist or stretch the belt.
4. When remounting the PC Board be sure to install the mica insulator between the transistor and the PC Board mounting bracket.

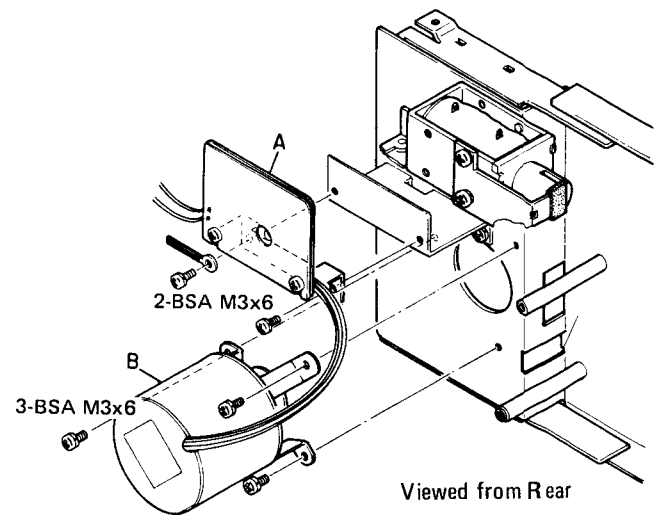

Fig. 4-6 Capstan Motor Replacement

4-8. CAPSTAN DRIVE ASS'Y/DRIVE BELT

First do procedures in section 4-1 and 4-3.

1. Remove the Control PC Board Ass'y (I) by taking off the 4 screws (J).
2. Detach the Flywheel Bearing Plate Ass'y (G) from the mounting studs by unscrewing the 4 screws (H).
3. Take out the Drive Belt (E) from the Motor Pulley (B) and the Flywheel (F).
4. Pull apart the Oil Retaining Washer (A) from the shaft of the Flywheel.
5. Carefully lift out the Flywheel from the Capstan Housing Ass'y (C).
6. Remove the Capstan Housing Ass'y from the chassis by unscrewing the 3 screws (D).

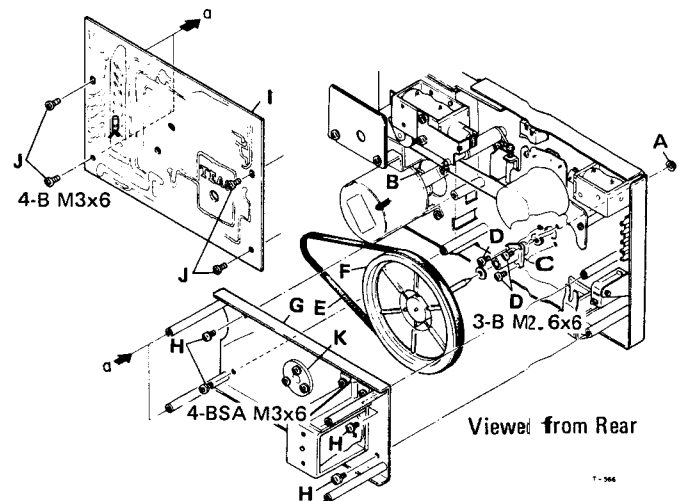

Fig. 4-7 Capstan Drive Ass'y/Drive Belt Replacements

NOTE

1. Since the Capstan Drive Ass'y is a precision part, TEAC specially distributes the Flywheel and the Capstan Housing Ass'y as a whole assembly. Hence, always replace the Flywheel together with the Capstan Housing Ass'y.
2. Clean all driving surfaces of the Flywheel and the Drive Belt with TEAC TZ-261 Cleaner kit ("A" for Flywheel, "B" for Belt) or with pure alcohol.
3. Do not bend the Capstan Shaft as this will increase wow/flutter or speed deviation.
4. During re-assembly re-attach the Drive Belt without twisting or stretching it.

LUBRICATION:

For lubrication of the newly replaced Capstan Drive Ass'y, the following should be observed.

1. Apply a drop of a light machine oil of good quality (e.g.: TEAC TZ-255) with an oil applicator to the shaft of the Flywheel and spread oil evenly over the shaft with a flannel cloth. After installing the Flywheel, be sure to clean the tape moving portion of shaft with TEAC TZ-261A Head Cleaner or with pure alcohol.
2. Apply a drop of the proper oil in the same way as above to the innermost area of capstan shaft (next to the Flywheel).
3. Apply a film of light grease to the well of the Flywheel Bearing Plate (K).

4-9. REEL MOTOR

First do procedures in section 4-1, 4-3 and 4-8.

1. Remove whole Reel Motor Ass'y (J) from the mounting studs by taking off the 3 screws.
2. Detach only the Motor body (I) by unscrewing the 3 screws from the Motor Base Plate Ass'y (H).
3. To further disassemble other parts illustrated in the box area, do the following steps.
4. Take off the screw (A), then separate the Fast Wind Idler Ass'y (B) from the Plate Ass'y (H). Pay special attention not to lose the Steel Ball (C).
5. Remove the Fast Wind Arm Plate (D) from the Plate Ass'y.
6. Disconnect the Spring (G) from the spring hook of the Tension Arm Ass'y (E), remove the 'E' ring (F), then lift off the Tension Arm Ass'y.

NOTE

When remounting the Fast Wind Idler Ass'y (B), clean the driving surface of the Idler with the TEAC TZ-261B Rubber Cleaner or with pure alcohol.

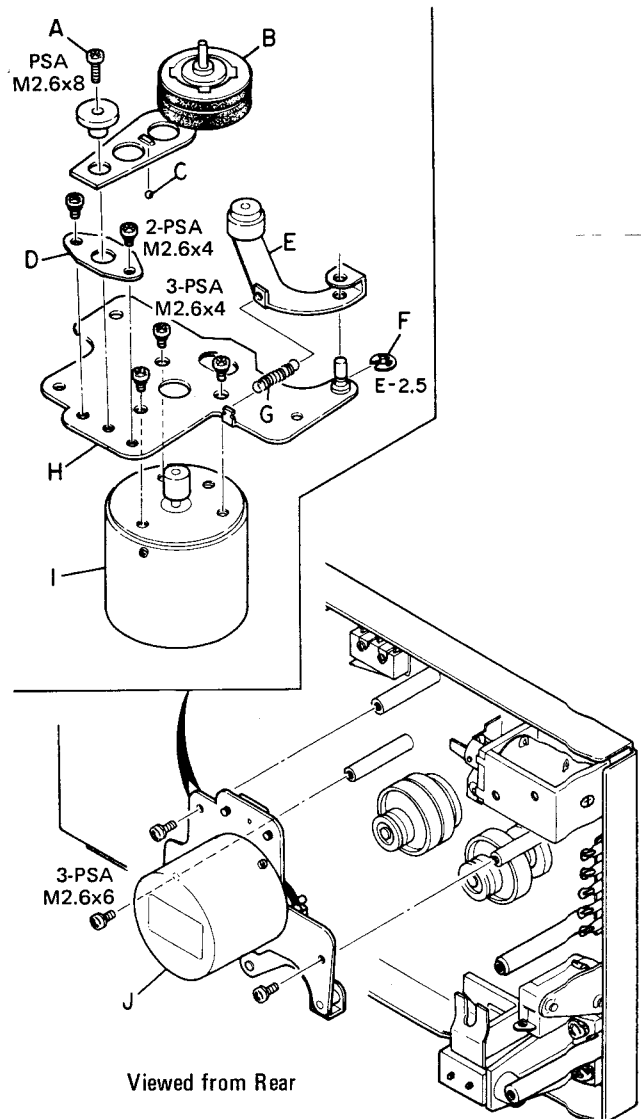

Fig. 4-8 Reel Motor Replacement

4-10. BRAKE PLATE ASS'Y

First do procedures in section 4-1, 4-3, 4-8 and 4-9.

1. Remove the Spring (G) by unhooking each end from the spring fastener on the chassis and the spring hook on the Plate (F) respectively.
2. Detach the Plate (F) by unscrewing the 2 screws.
3. Remove parts (E) (D) (B) (A: Brake Plate Ass'y) illustrated all the way in that sequence.
4. Remove each Brake Shoe (C) from the Brake Plate Ass'y.

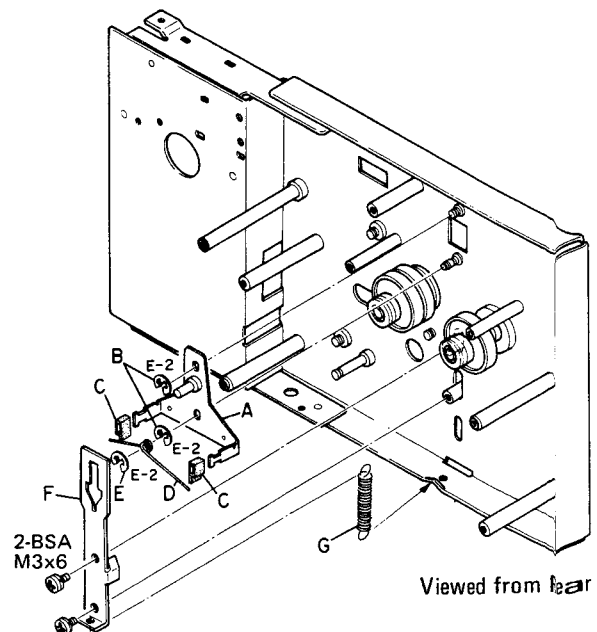

Fig. 4-9 Brake Plate Ass'y Removal

4-11. REEL TABLES

First do procedures in section 4-1, 4-2, 4-6 and 4-8.

Take off the screws mounting the Reel Table which requires replacement.

NOTE

Always replace the complete Reel Table Ass'y as an entire assembly, "Take-up" or "Supply".

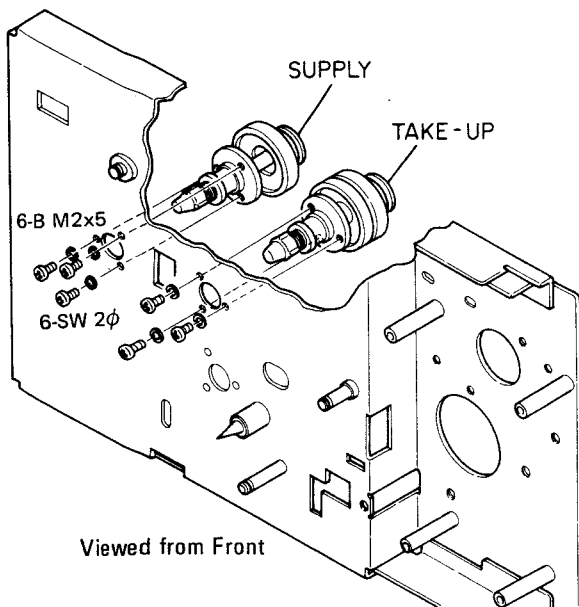

Fig. 4-10 Reel Tables Replacement

4-12. IDLER ASS'Y

First do procedures in section 4-1, 4-3 and 4-8.

1. Remove Spring (C) from the mounting pin (A).
2. Remove E-ring (E) from the pivot pin (B).
3. Lift out the Idler Ass'y (D).

NOTE

When remounting the Idler Ass'y, clean the driving surface of the Idler with the TEAC TZ-261B Rubber Cleaner or with pure alcohol.

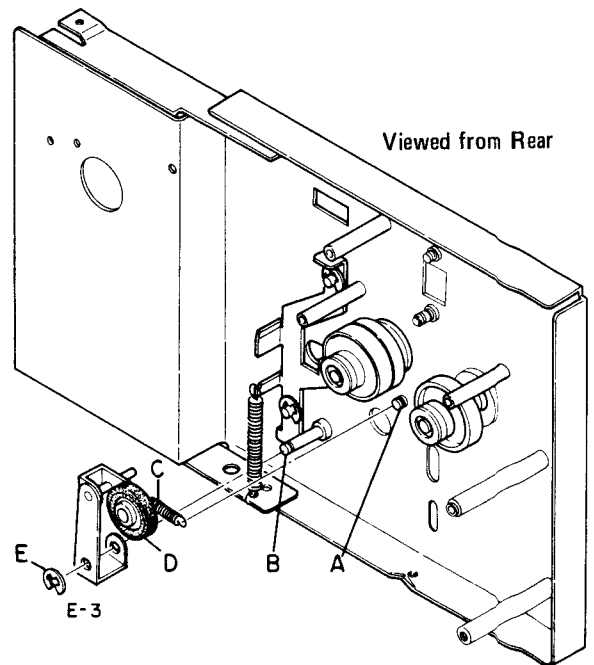

Fig. 4-11 Idler Ass'y Replacement

LUBRICATION

NOTE

1. Lubrication should be generally done at about every 1,000 hours of operating time of the tape deck. Use high quality oil for this purpose.
2. For efficient oiling, it is recommended that lubrication be done after nearly 1 hour of idling of the deck, and while it is still warm.
3. Normally, it is necessary to lubricate only the following two areas:

a. FLYWHEEL ASS'Y

See Section 4-8 for lubrication of the newly replaced Flywheel Assy.

b. CAPSTAN ASS'Y

Apply 1 or 2 drops (approx. 0.2 cc) of a light machine oil with an oil applicator to the shaft bearing portion of the Capstan Assy.

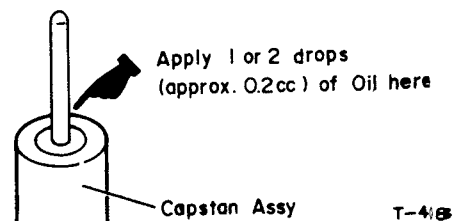

Fig. 4-12 Lubrication of Capstan Ass'y

5. MECHANICAL CHECKS AND ADJUSTMENTS

NOTE

All the mechanical checks and adjustments should be done with the external Cases removed. (See Section 4-1).

5-1. TAKE-UP TORQUE

Specification: 40 ~ 70 g·cm (0.6 ~ 1.0 oz·inch)

1. Remove the Cassette Holder. See 4-6 section on page 8.
2. Switch on POWER.
3. Set the Cassette Reel Adapter (22 mm Dia.), connected to the spring scale (0 ~ 70 g, or 0 ~ 2.5 oz.) by the string as shown in Fig. 5-1 on the Take-up Reel Table.
4. Place the deck in the PLAY mode.
5. Allow the rotation of the Reel Table to pull the scale pointer toward the Adapter with the spring scale moving in the same direction at nearly the same speed as the tape would be moved, and obtain the scale reading. Make reading only when the pointer becomes stable.
6. The scale should indicate Force of 36 ~ 64 g (1.3 ~ 2.2 oz.).
This corresponds to a torque of 40 ~ 70 g·cm (0.6 ~ 1.0 oz·inch). For the torque calculation, refer to Fig. 5-2.
7. If the reading is out of specified range, clean the driving surfaces of the Reel Table Ass'y, and all other driving parts relative to the take up torque function with the TEAC TZ-261B Rubber Cleaner or with pure alcohol.
8. If the above cleaning is ineffective for torque correction, replace the Reel Table Ass'y. (See Section 4-11).

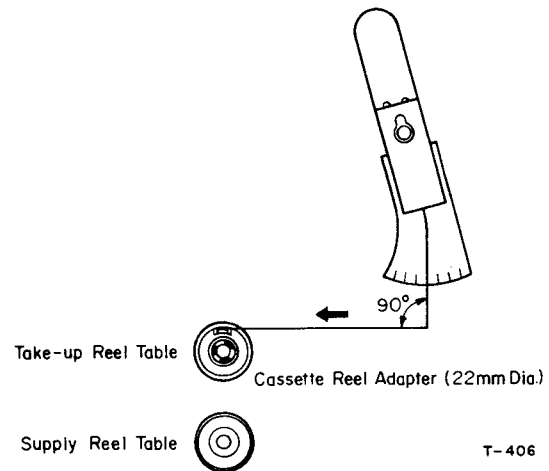
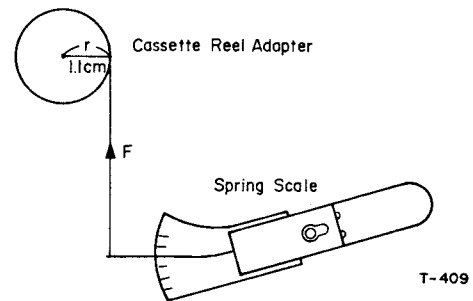

Fig. 5-1 Take-up/Fast Forward Torque Measurement



$$T = F \times r$$

For example:
If $F = 36 \text{ g}$
 $T = F \times r$
 $= 36 \times 1.1$
 $= 40 \text{ (g·cm)}$
Consequently the torque is 40 g·cm

Fig. 5-2 Torque Calculation Method

5-2. FAST FORWARD & REWIND TORQUE

Specification: 100 ~ 150 g·cm (1.4 ~ 2.1 oz·inch)

NOTE

Note that the Fast Forward and Rewind torque should be measured before the Auto-End Stop Facility functions.

5-2-1. FAST FORWARD TORQUE

1. Repeat step 1 and 2 in 5-1 section.
2. Set the Cassette Reel Adapter (22 mm Dia.), connected to the spring scale (0 ~ 200 g, or 0 ~ 7.0 oz.) by the string as shown in Fig. 5-1, on the Take-up Reel Table.
3. Place the deck in the Fast Forward mode.
4. Allow the rotation of the Reel Table to pull the scale pointer toward the Adapter, and obtain the scale reading. Do not read until the pointer becomes stable.
5. The scale should indicate 91 ~ 136 g (3.2 ~ 4.8 oz.). This corresponds to a torque of 100 ~ 150 g·cm (1.4 ~ 2.1 oz·inch).

6. If the indication is out of specified range, clean the driving surfaces of the Reel Table Ass'y and all other driving parts relative to the fast forward torque function with the TEAC TZ-261B Rubber Cleaner or with pure alcohol.

5-2-2. REWIND TORQUE

1. Repeat the FAST FORWARD TORQUE procedure, but use the Supply Reel Table and Rewind mode for measuring the rewind torque.
2. The specified value is the same as that of the fast forward torque.

TORQUE MEASUREMENT USING THE CASSETTE TORQUE METER

The torque measurements can be easily done with the Cassette Torque Meter indicated below.

For take-up torque measurement: 0 ~ 100 g·cm
(0 ~ 1.4 oz·inch)

For fast forward and rewind torque measurements: 0 ~ 160 g·cm
(0 ~ 2.2 oz·inch)

By use of a Cassette Torque Meter, it is possible to directly obtain the torque value without calculation, and to do the measurement simply with no removal of any parts. If repairs are necessary, the external Cases must be removed. Load the Meter on the deck and read the pointer indication on the dial scale for each tape movement operation.

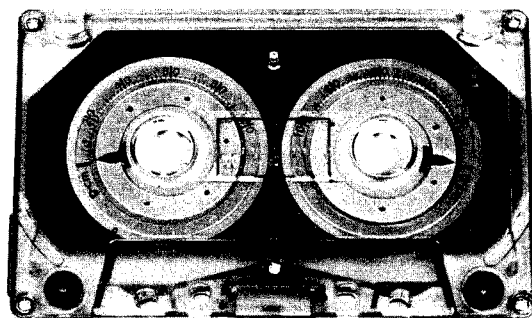

Fig. 5-3 Cassette Torque Meter

5-3. PINCH ROLLER PRESSURE

Specification: 400 g ± 20 g (13.5 ~ 15.0 oz.)

1. Switch on POWER.
2. Press the Switch Arm (A) shown in Fig. 5-5 so that the CASSETTE IN Switch (S509) (see Fig. 5-11) will activate.
3. Place the deck in the PLAY mode with no tape loaded.
4. Attach the spring scale to the hole in the Pinch Roller Ass'y as shown.
5. Gently draw the Pinch Roller away from the Capstan shaft (in a direction parallel to a line that intersects the centers of the capstan shaft and the Pinch Roller) until the Capstan shaft and the Pinch Roller are completely separated.
6. Gradually return the scale back until the Pinch Roller just begins to rotate. The scale should then be reading approximately 400 ± 20 g (13.5 ~ 15.0 oz.).
7. If the reading is out of specified range, adjust the tension of the Pressure Spring by bending the tab of the Pinch Roller Ass'y slightly.

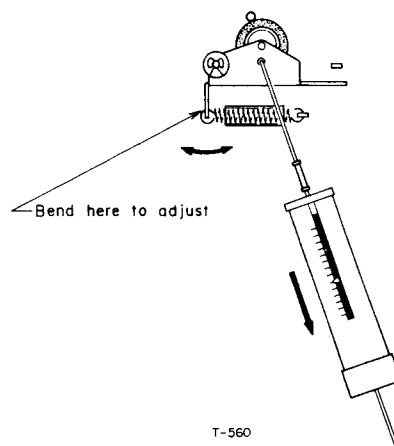

Fig. 5-4 Pinch Roller Pressure Measurement

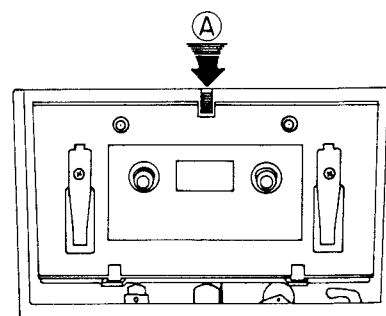

Fig. 5-5 Switch Arm Location

5-4. BRAKE TENSION

1. Switch on POWER.
2. Load a TEAC MTT-501 test tape.
3. Check for excess slack or tightness of the tape when operation is changed from play, fast forward and rewind mode to stop mode, respectively.
4. If brake action is too "tight" or "loose", adjust by bending the arms of the Brake Bracket in or out as shown by the arrows in Fig. 5-6.

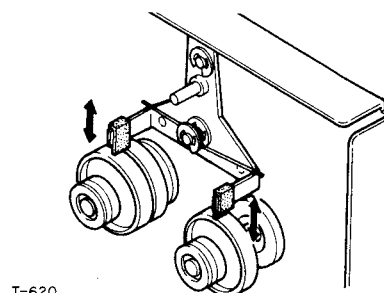

Fig. 5-6 Brake Tension Adjustment

5-5. TAPE SPEED/WOW AND FLUTTER

Specification:

Tape Speed Deviation:	3,000 Hz \pm 30 Hz
Tape Speed Drift:	15 Hz
Wow and Flutter:	Playback: 0.07% (WRMS) 0.15% (RMS) Record/Playback: 0.18% (RMS)

NOTE

1. Before performing this adjustment, clean all parts in the tape path, particularly the Capstan, the Pinch Roller and the Heads with the appropriate liquid from the TEAC TZ-261 Cleaner Kit or with pure alcohol.
2. Wow and flutter should be checked in two ways; Playback only and Record/Playback methods. First correct tape speed and wow and flutter using the playback only method. Then measure wow and flutter using record and playback method.
3. As the measured results may vary with respect to location on tape at which it was taken, three points – at beginning, middle and near the end of the tape – should be measured. The worst case reading must satisfy the specification.

5-5-1. TAPE SPEED

1. Connect test equipment to the deck, except the AF oscillator, as shown in Fig. 5-7.
2. Set the OUTPUT control on the deck to obtain convenient output.
3. Set the EQ switch to the "3" position, and then load and play a TEAC MTT-111 test tape (3,000 Hz signal is recorded).
4. Adjust the semi-fixed resistor as shown in Fig. 5-8 for reading of 3,000 Hz \pm 5 Hz on the frequency counter. (NOTE: This tape speed setting should be done after approx. 30 seconds of operating time of the deck.)
5. Then, verify the reading on the frequency counter as within the specified range of 3,000 Hz \pm 30 Hz, and the Tape Speed Drift is within 15 Hz at any portion of the tape run.
6. If the tape speed is extremely out of the specification, check the Pinch Roller pressure and the tape driving function for correction, and make sure the tape path is clean.

5-5-2. WOW AND FLUTTER

After making the tape speed measurement, perform the wow and flutter test using the Playback Method and the Record/Playback Method successively.

PLAYBACK METHOD

1. Play the MTT-111 test tape.
2. Read the indication on the wow and flutter meter.
3. The wow and flutter value should be 0.07% WRMS, max. or 0.15% RMS, max.
4. If the wow and flutter is out of specification, check the Pinch Roller pressure and the take-up torque, see that the tape path is clean, and that the Capstan Belt is not stretched or oily.
5. If the above checks are ineffective for excessive wow and flutter correction, repair or replace the Pinch Roller, the Capstan Belt and/or any other defective parts.

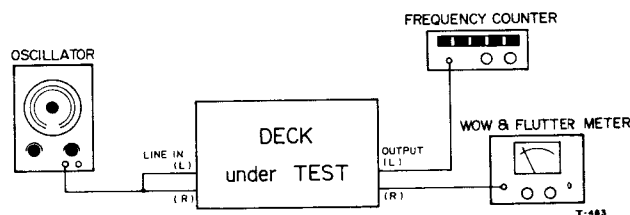

Fig. 5-7 Tape Speed/Wow & Flutter Measurement Setup

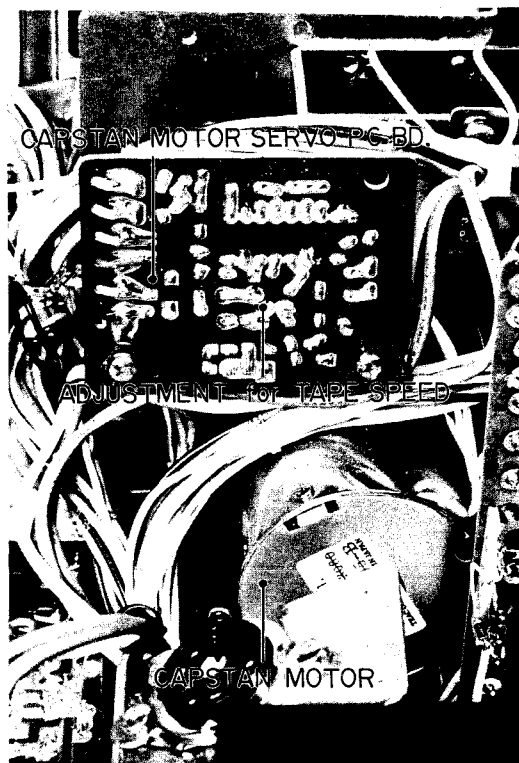

Fig. 5-8 Tape Speed Adjustment Location

RECORD/PLAYBACK METHOD

NOTE

When using this method, adopt the maximum wow and flutter value obtained by repeated play and stop modes of operation. This operation is necessary to make sure wow and flutter content between record and playback will not be in phase to create a false reading.

1. Connect test equipment to the deck as shown in Fig. 5-7.
2. Set **LINE** and **OUTPUT** controls on the deck to obtain convenient input and output levels.

3. Load a TEAC MTT-502 test tape (blank) and set the **BIAS/EQ** switches in the "3" positions.
4. Apply and record a 3,000 Hz signal.
5. Rewind and play this recorded section.
6. Read the indication on the wow and flutter meter.
7. The wow and flutter value should be 0.18% RMS max.
8. If the measured value is out of specification, repair using the same methods as stated in steps 4 – 5 in the Playback Method procedure.

VISUAL INDEX (for 5-6, 7, 8, 11 Sections)

To readily locate the specified checkout areas described in 5-6, 7, 8, 11 Sections, refer to Fig. 5-9.

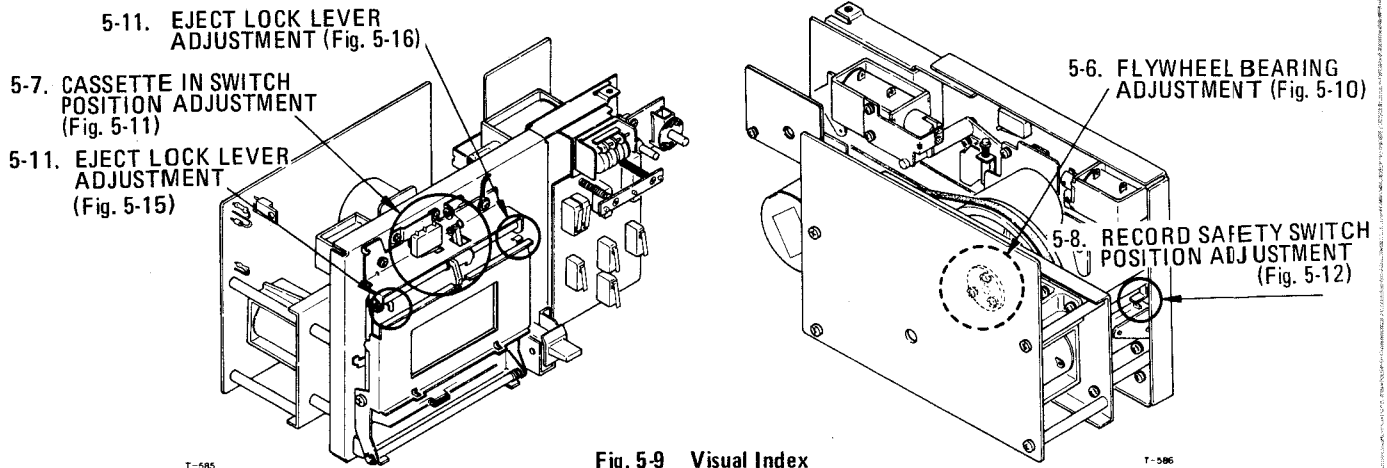

Fig. 5-9 Visual Index

5-6. FLYWHEEL BEARING ADJUSTMENT

1. Close the Cassette Holder with the Holder empty so that the Switch Arm located on the top of the Cassette Holder is not depressed and the Capstan Motor is not turning.
2. Depress the **PAUSE** Button to engage the Play Solenoid.
3. By using a slot screwdriver with small blade, adjust the Thrust Screw so that there is a gap of 0.1 to 0.3 mm between the lower end of the Capstan Shaft and the well of the Flywheel Bearing. This adjustment can be made by pushing the Flywheel toward or away from the front of the deck.

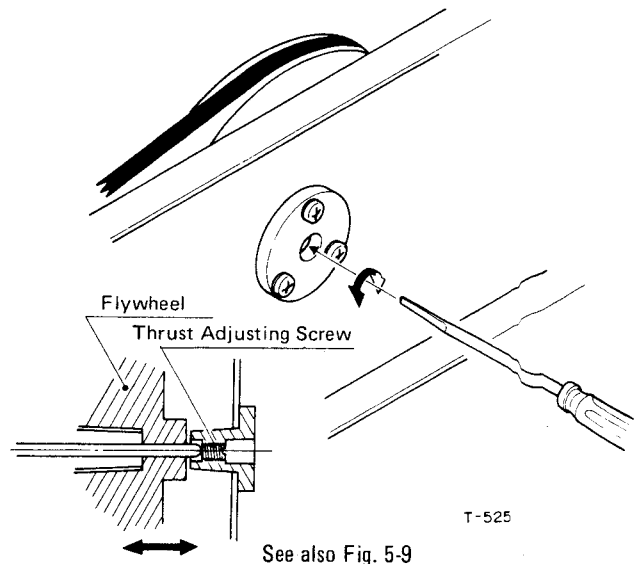
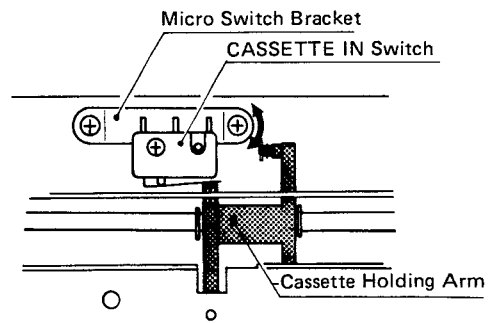

Fig. 5-10 Flywheel Bearing Adjustment

5-7. CASSETTE IN SWITCH POSITION ADJUSTMENT

1. Be sure that when inserting any cassette tape in the Cassette Holder and closing it, the Cassette In Switch (S509) is actuated to run the Capstan Motor.
2. If the Capstan Motor does not rotate, loosen the screw on the right end of the Micro Switch Bracket, and then rotate the Bracket so that the Switch is engaged to ON.
3. After adjusting, retighten the loosened screw.



See also Fig. 5-9 T-526
Fig. 5-11 CASSETTE IN Switch Positioning

5-8. RECORD SAFETY SWITCH POSITION ADJUSTMENT

1. Insert any cassette tape with the record protection tab removed in the Cassette Holder and close Cassette Holder.
2. Then, ensure that the Record Preventing Lever moves downward, thus closing the Record Safety Switch (S512).
3. If the Switch does not close, loosen the screw fixing the Micro Switch Bracket and adjust the Switch position by moving the Bracket for proper activation of the Switch.

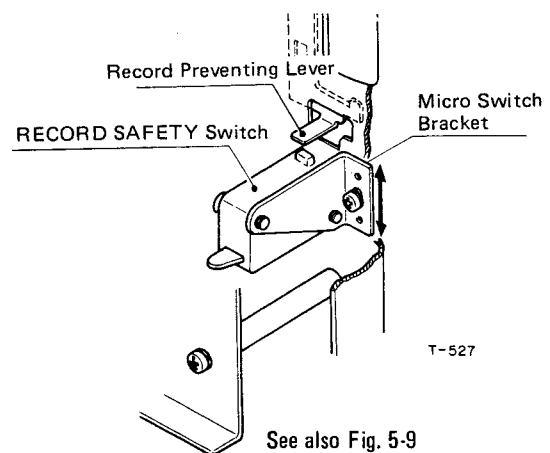

See also Fig. 5-9 T-527
Fig. 5-12 Record Safety Switch Positioning

5-9. CASSETTE HOLDER MOTION CHECKS

1. Load the TEAC MTT-501 test tape or equivalent.
2. Ensure that when depressing the Eject Lever, the Cassette Holder Door is opened smoothly without binding from the closed condition.
3. Close the Cassette Holder with no Cassette in the Holder.
4. Check that the Cassette Holder will open fully when the Eject lever is depressed as above.
5. Load a cassette tape in the opened Cassette Holder Door and check that the cassette shell does not come into contact with the capstan shaft or safety shaft fixed on the chassis.

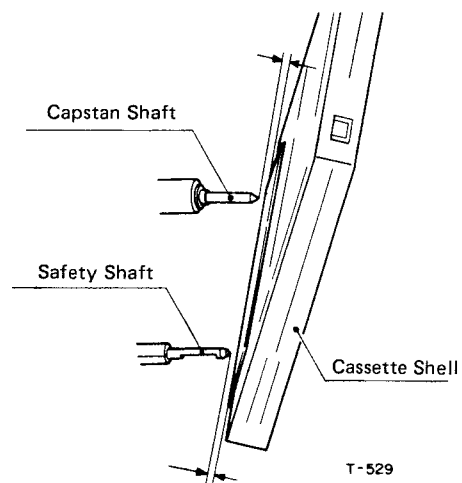
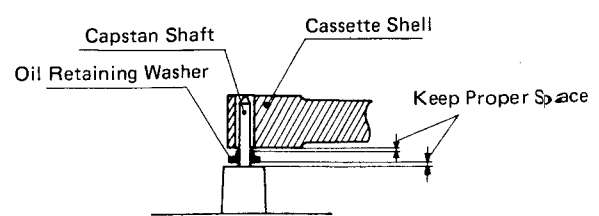

Fig. 5-13 Cassette Holder Motion Checks T-529

5-10. OIL RETAINING WASHER CLEARANCE CHECK

1. Load a standard shape cassette on the deck.
2. Make certain that both surfaces of the Oil Retaining Washer are properly spaced from one side of the Cassette Shell and the top end of the Capstan Housing by rotating the Flywheel manually. See Fig. 5-14.



T-530
Fig. 5-14 Oil Retaining Washer Clearance Check

5-11. EJECT LOCK LEVER ADJUSTMENT

1. Insert any cassette tape with the record protection tabs removed, then close Cassette Holder Door.
2. Ascertain that when depressing the Eject Lever, the Cassette Holder Door is released from the Lock Lever after the bent-tip of the Record Preventing Lever is extracted perfectly out of the tab hole of the Cassette.
3. If the bent-tip of the Record Preventing Lever does not fully clear the hole or the Lock Lever does not free the Cassette Holder, make adjustment by bending the tab of the Lock Lever in either direction as shown by the arrows in Fig. 5-16.

Note that the Lock Lever must be allowed to open the Cassette Holder after the Record Preventing Arm is completely pulled out of the record protection tab hole.

4. The Cassette Holder always should remain locked even when any place on the Cassette Holder Door is pushed toward the inside of the deck.

Bent-tip of Record Preventing Lever

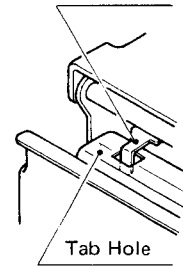

See also Fig. 5-9

Fig. 5-15 Record Protection Tab Location

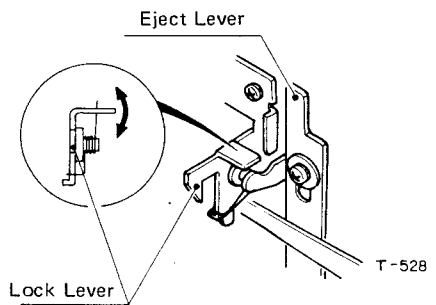

See also Fig. 5-9

Fig. 5-16 Lock Lever Location

VOLTAGE AND FREQUENCY SETTING

a. VOLTAGE SELECTOR SETTING PROCEDURE (FOR GENERAL EXPORT MODELS)

1. Disconnect the power cord of the deck from the source.
2. Turn the deck over and locate the voltage selector on the bottom of the deck.
3. Loosen the screw on the cut-out end of the metal bar covering the voltage selector and then rotate the bar so the slotted center post of the voltage selector can be adjusted.
4. To increase the selected voltage, turn the slotted center post clockwise using a screwdriver or other suitable tool.
5. To decrease the selected voltage, turn the slotted center post counter-clockwise.
6. The numerals that appear in the cut-out window of the voltage selector indicate the selected voltage.
7. Re-install the metal bar.

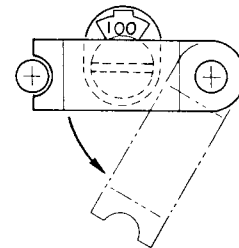

INCREASE DECREASE

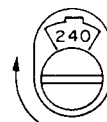
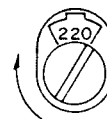
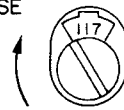

Fig. 5-17 Voltage Selector Setting

b. AC POWER LINE FREQUENCY ADAPTATION

Since the A-650 employs a PLL Servo DC Motor, 50 Hz or 60 Hz operation is possible without power line frequency adaptation.

5-12. PUSHBUTTON CONTROL CHECKS

REC BUTTON

1. The deck should go into the Record mode only when a recordable tape is installed.
2. The Record mode should be achieved only when both REC and Play Buttons are depressed at the same moment.
3. While the deck is running in the Play mode, when both Play and Record Buttons are pushed together, the deck should go into the Record mode. . . . Punch-in Recording feature check.
4. When the Fast Forward, Rewind or STOP Buttons are depressed during the Record mode, Record mode should be released.

FAST FORWARD BUTTON

1. The Fast Forward operation should be achieved by pressing the Fast Forward Button only.
2. When the Fast Forward Button is depressed during any other modes, the Fast Forward function should be activated.
3. When either the PAUSE, Play, Rewind or STOP Button is pushed, the Fast Forward mode should cease to function.

REWIND BUTTON

1. The Rewind operation should be achieved by pressing the Rewind Button only.
2. When the Rewind Button is depressed from any other modes, the Rewind action should be achieved.
3. When either the PAUSE, Play, Fast Forward or STOP Button is pushed, the Rewind mode should be released.

PLAY BUTTON

1. Play operation should be achieved by depressing the Play button only.
2. When the Play Button is depressed during Fast Forward or Rewind operation, a delay time of 0.7 ± 0.3 second is required before Play mode is begun.
3. When the Play Button is depressed from any other modes (with the exception of Record, Record Muting and Record Pause), the Play function should be achieved.
4. When either Fast Forward, Rewind, PAUSE or STOP Button is depressed, the Play mode should be disengaged.

STOP BUTTON

When the STOP Button is depressed from any other modes, the selected operation mode should be released to stop tape motion.

PAUSE BUTTON

1. The PAUSE function should be engaged, only when the PAUSE Button is depressed.
2. When the PAUSE Button is depressed from any other modes, the deck should go into the Pause mode. (When the PAUSE Button is depressed from the Record or Record Mute mode, the machine should go into the Record Pause mode.)
3. When either Play, Fast Forward Rewind or STOP Button is depressed with the Pause facility engaged, the Pause mode should be released.

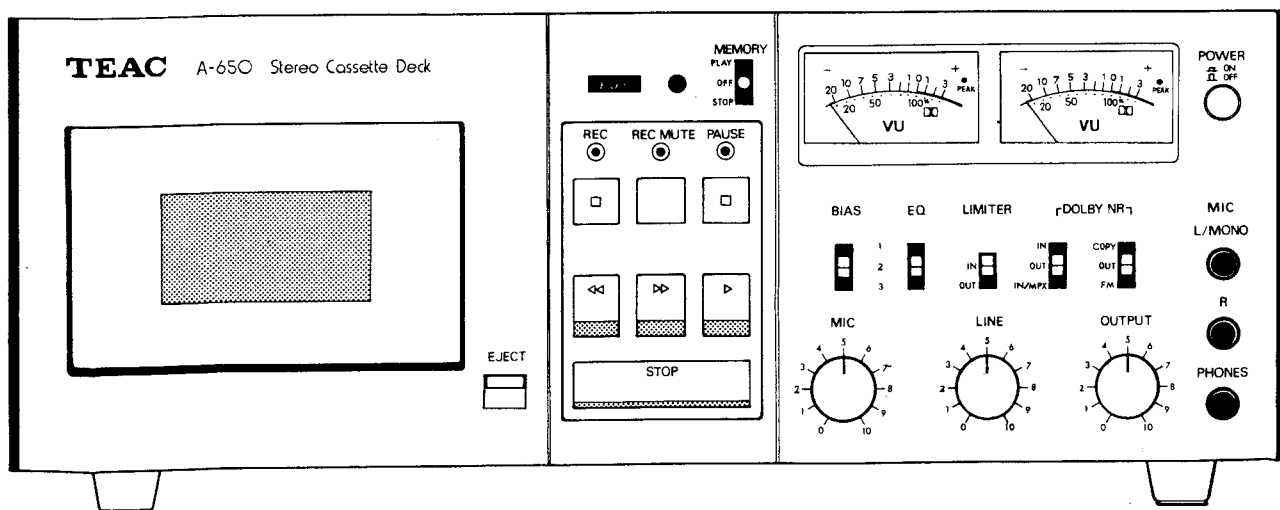

Fig. 5-18 Front Panel View

REC MUTE BUTTON

1. The Record Mute mode should be activated from only the Record mode.
2. If the PAUSE, Play, Fast Forward, Rewind or STOP Button is depressed, the Record Mute mode should be disengaged.

EJECT LEVER

1. During the Play, Record Pause or Record Mute mode, ensure that the EJECT Lever cannot be depressed to open the Cassette Holder.
2. The EJECT Lever can be depressed to open the Cassette Holder from the STOP, Fast Forward or Rewind mode.
3. When the EJECT Lever is depressed, be sure that the Cassette Holder opens far enough, the lamp located at the rear of the Cassette Holder is extinguished, the Drive Motors stop and all control operations are disabled.

5-13. AUTO-END STOP FACILITY CHECK

1. Check that when the cassette reaches the end of tape from each mode with the MEMORY Switch OFF, the Take-up Reel stops rotating and the deck releases the drive mechanism automatically.
2. The End-stop Activate Time (the time between the stopping of the take-up reel table and stop mode of the deck) should be 1.5 ± 0.5 seconds.

5-14. MEMORY DEVICE FUNCTION CHECKS

a. MEMORY PLAY FUNCTION

1. Set the MEMORY Switch to PLAY.
2. Depress the Index Counter reset button, depress Play Button to run the tape forward until the Index Counter indicates 003 or higher (but less than 900) then depress Rewind Button.
3. Check that the tape stops for a short moment when the Counter reaches 999, then the Play mode begins automatically.

b. MEMORY STOP FUNCTION

1. Place the Switch in the STOP position.
2. Set deck in the Rewind mode with the Counter indicating 003 or a larger numeral (but less than 900).
3. Check that the tape halts when the Counter winds back down to 999.

6. ELECTRICAL CHECKS AND ADJUSTMENTS

GENERAL NOTES

1. Before performing adjustments on the amplifier section of this deck, thoroughly clean and demagnetize the entire tape path, particularly erase head, record/playback head, capstan shaft and pinch roller.
 2. Make sure the deck is set for the proper voltage for your locality.
 3. In general, checks and adjustments for other than specified items, are done in the sequence of left channel then right channel. Double designated REF. NO. indicates left channel/right channel (example: VR 101/201).
 4. Value of "dB" in the text refers to 0 dB = 0.775 V, except where specified. If a VTVM calibrated to 0 dB = 1 V is to be used, appropriate compensation should be made.
 5. The VTVM used in the procedures, including the measurement at CAL test points, must have load impedance of $1M\Omega$ or more.
 6. To correctly complete these performance checks, keep the order as explained in this chapter.
 7. All checks and adjustments should be made with Top Cabinet removed. (See Section 4-1).
- * For each procedure, make the initial equipment test set up, connections and switch/control settings as shown in the associated illustrations.
- * Each of the switch settings marked with hyphen (-) in the Switch Setting chart have no effect on the procedures.

6-1. ADJUSTMENT LOCATION

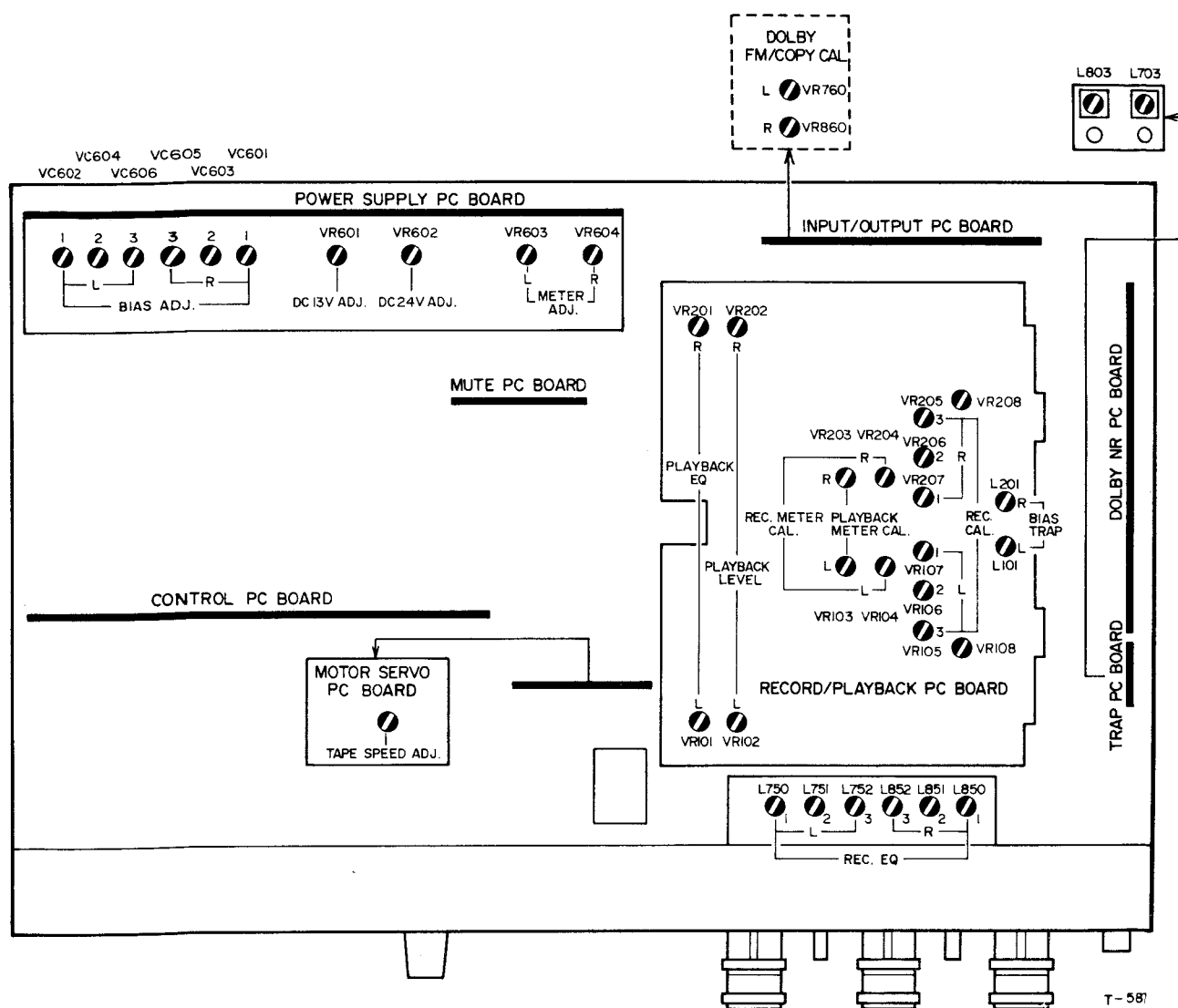

Fig. 6-1 Adjustment Location

VR101/201	Playback EQ	VR760/860	DOLBY FM/COPY calibration
VR102/202	Playback level	VC602/601	Record bias (1)
VR103/203	VU meter calibration (Playback)	VC604/603	Record bias (2)
VR104/204	VU meter calibration (Record)	VC606/605	Record bias (3)
VR105/205	Record level (3)	L101/201	Bias trap
VR106/206	Record level (2)	L703/803	Bias trap
VR107/207	Record level (1)	L750/850	Record EQ (1)
VR108/208	Peak level indicator adjustment	L751/851	Record EQ (2)
VR601	DC 13 V adjustment	L752/852	Record EQ (3)
VR602	DC 24 V adjustment		

DC VOLTAGE ADJUSTMENT

- a. **ADJUSTING FOR +13 V**
 1. Apply AC power to the deck and set the POWER Switch to IN.
 2. Connect the DC Voltmeter between #11 terminal (+) of the 16P Plug and ground.
 3. Adjust VR601 to provide the desired D.C. output voltage of +13 V.
- b. **ADJUSTING FOR +24 V**
 4. Change connecting point of the DC Voltmeter to #10 terminal of the Plug (+) and ground.
 5. Adjust VR602 for +24 V.

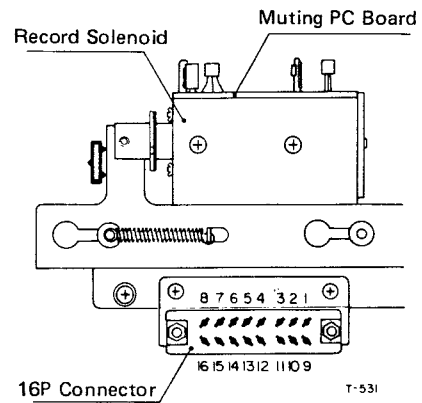

Fig. 6-2 DC Voltage Adjustment

6-2. PLAYBACK PERFORMANCE

NOTE

Except for the Playback Frequency Response checks, all alignments in the PLAYBACK PERFORMANCE have to be done with the EQ switch set to position 3 only unless there is a special reason which requires that other positions also be checked.

6-2-1. RECORD/PLAYBACK HEAD AZIMUTH ADJUSTMENTS

1. Load and play a TEAC MTT-150 test tape.
2. Make sure the phase relationship between the 2 signals (left channel and right channel) is within 45° on the oscilloscope.
3. Load a TEAC MTT-116U test tape.
4. Play the 10 kHz signal section of the tape.
5. Slowly adjust the azimuth adjusting nut for the maximum indication on the VTVM.
6. Secure the nut with a drop of locking paint.

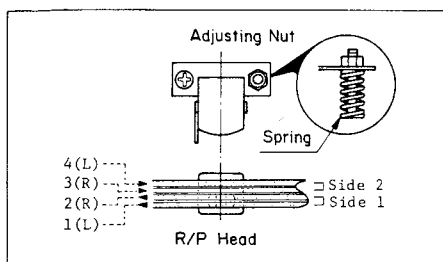

Fig. 6-4 Head Azimuth Adjustments Location

Preparations:

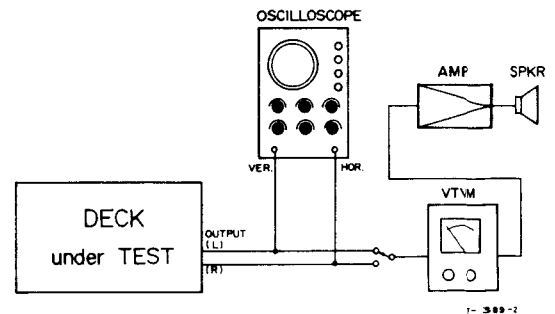

Fig. 6-3 Connection

Switch Setting:

BIAS	EQ	LIMITER	DOLBY NR	
-	3	-	OUT	OUT

Control Setting:

OUTPUT: Set for convenient output level.

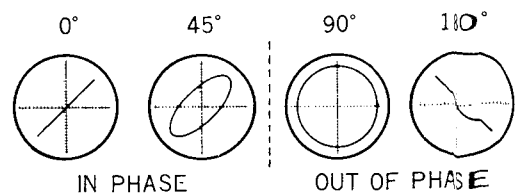

Fig. 6-5 Confirming Phase Relationship

6-2.2. SPECIFIED OUTPUT LEVEL SETTING

Specifications:

Specified output level: -5 dB (435 mV)
 Maximum output level: $+1 \text{ dB} \pm 1 \text{ dB}$
 (0.775 V \sim 0.975 V)

1. Load and play a TEAC MTT-150 test tape.
2. Adjust VR102/202 for 580 mV (-2.5 dB) on VTVM connected to the CAL test points, as shown in (A) of Fig. 6-6.
3. Change the VTVM connection to the OUTPUT jacks as shown in (B) of Diagram.
4. Place the DOLBY NR IN-OUT-IN/MPX switch in the OUT position.
5. Set the OUTPUT controls fully clockwise.
6. Confirm that the output level is $+1 \text{ dB} \pm 1 \text{ dB}$ (0.775 V \sim 0.975 V).
7. Set the OUTPUT controls for a reading of -5 dB (435 mV). This is the specified output level. At this time, the physical position of the OUTPUT controls indicates the Specified Control Setting referred to in subsequent procedures.

IMPORTANT

After this setting is done, do not disturb the Specified Control Setting of the OUTPUT controls until the remaining checks and adjustments are completed.

6-2.3. FREQUENCY RESPONSE –PLAYBACK–

NOTE

In the following procedure, adjust VR101/201 so that the measured values on all settings of the EQ switch are within the specified response limits.

CrO₂ & Fe-Cr TAPES

8. Load a TEAC MTT-116K test tape and play its test signals from 40 Hz up to 14 kHz.
9. Adjust VR101/201 so that the readings of the higher frequency signals on the VTVM are within the response limits.

Hi-Fi TAPE

10. Repeat the above procedure, with the following exceptions.

Test tape: MTT-116U
 EQ switch: "3" position

NOTE

If the response does not meet the specified response limits, the head should be checked for accumulated oxide or dirt. Then, if no dirt is found the head azimuth should be readjusted.

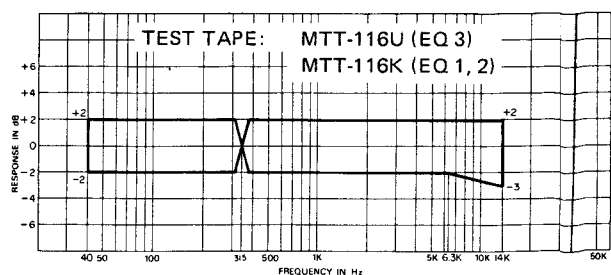
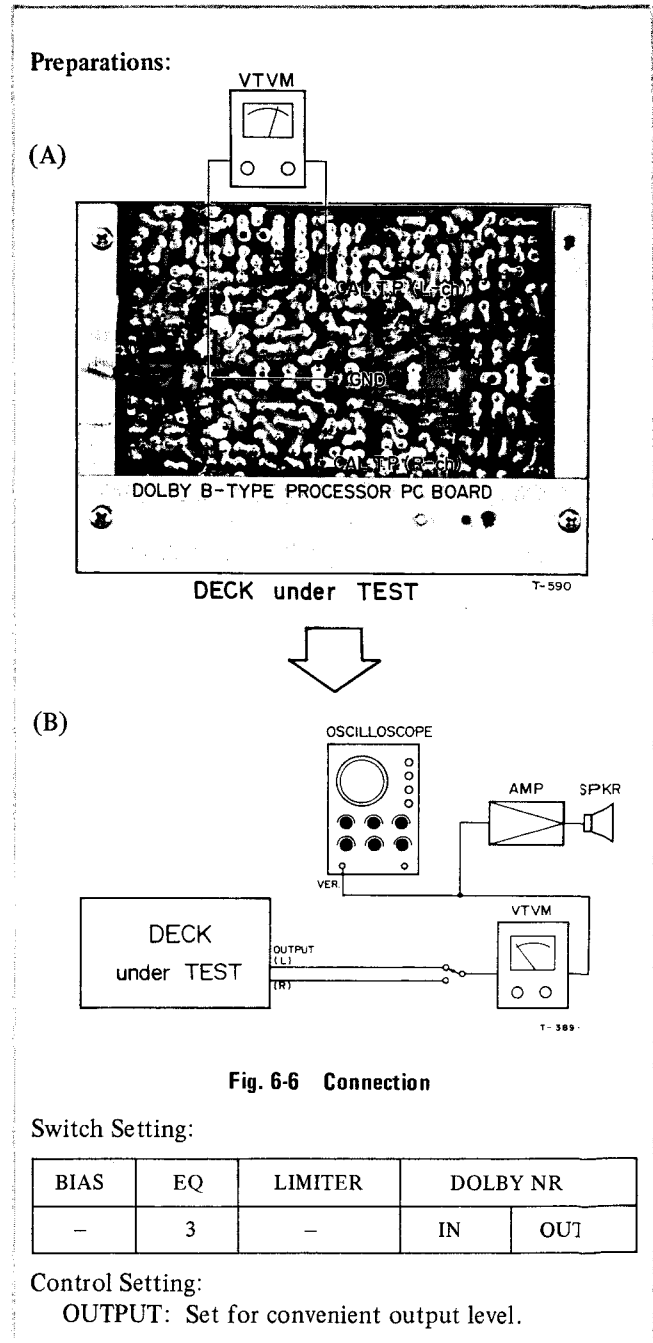

Fig. 6-7 Playback Frequency Response Limits

6-2.4. SIGNAL TO NOISE RATIO –PLAYBACK–

Specifications:

CrO₂ & Fe-Cr tapes. 48 dB (minimum)
 Hi-Fi tape: 46 dB (minimum)

1. Load and play a completely erased or degaussed TEAC MTT-501 test tape.
2. Read the indication on the VTVM.
3. The VTVM should indicate -51 dB minimum (2.18 mV maximum).
4. This corresponds to a signal-to-noise ratio of 46 dB (minimum): difference between residual noise -51 dB and the specified output level -5 dB (435 mV).

NOTE

Since the polarity of the AC plug has some effect on the signal-to-noise ratio, the plug can be reversed in the wall socket when checking the signal-to-noise ratio. The worse case value should be within the indicated value above.

Preparations:

Connection: See Fig. 6-6 (B) on page 22.

Switch Setting:

BIAS	EQ	LIMITER	DOLBY NR	
-	3	-	OUT	OUT

Control Setting:

OUTPUT: Specified Setting (See 6-2-2)

6-2.5. VU METER CALIBRATION –PLAYBACK–

Specification. +3 VU ()

IMPORTANT

VU meter calibration must also be conducted after that of MONITOR PERFORMANCE (see 6-3-3 on page 24) is completed.

1. Load and play a TEAC MTT-150 test tape.
2. Adjust VR103/203 for +3 VU () on the VU meter.

Preparations:

Connection: See Fig. 6-6 (B) on page 22.

Switch Setting:

BIAS	EQ	LIMITER	DOLBY NR	
-	3	-	OUT	OUT

Control Setting:

OUTPUT: Specified Setting (See 6-2-2)

6-2.6. HEADPHONE OUTPUT LEVEL CHECKS

Specification. -15.7 dB ± 2 dB (103 mV ~ 163 mV)

NOTE

An 8 ohm non-inductive resistor should be used as the test load resistor.

1. Load and play a TEAC MTT-150 test tape.
2. Measure the level across the test load resistor.

Preparations:

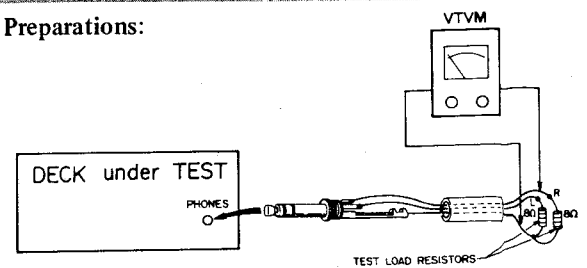

Fig. 6-8 Connection

Switch Setting:

BIAS	EQ	LIMITER	DOLBY NR	
-	3	-	OUT	OUT

Control Setting:

OUTPUT: Specified Setting (See 6-2-2)

6-3. MONITOR PERFORMANCE

6-3-1. MINIMUM INPUT LEVEL CHECKS

Specifications:

- LINE: $-19 \text{ dB} \pm 2 \text{ dB}$ (69 mV ~ 109 mV)
 MIC: $-67 \text{ dB} \pm 2 \text{ dB}$ (274 μV ~ 435 μV)
 DIN: $-35 \text{ dB} \pm 2 \text{ dB}$ (10.9 mV ~ 17.3 mV)

NOTE

To prevent mis-measurements for the following procedures, any connection cords other than those for the respective input check must be removed.

For example: Do not connect the Microphone and the DIN cords to respective input jacks when checking for the LINE inputs.

1. Load any recordable tape.
2. Place the deck in the RECORD-PAUSE mode.
3. Set the MIC controls to maximum.
4. Apply a 400 Hz signal at $-67 \text{ dB} \pm 2 \text{ dB}$ (274 μV ~ 435 μV) to the MIC jacks and check for 580 mV (-2.5 dB) on the VTVM connected to the CAL test points. (Minimum Input Level checks for the MIC jack).
5. Apply a 400 Hz signal at $-35 \text{ dB} \pm 2 \text{ dB}$ (10.9 mV ~ 17.3 mV) to the input terminals of the DIN connector and check for 580 mV. (Minimum Input Level checks for the DIN inputs).
6. After checking, reduce the MIC controls to minimum to prevent noise insertion during subsequent procedures.
7. Set the LINE controls to maximum.
8. Apply a 400 Hz signal at $-19 \text{ dB} \pm 2 \text{ dB}$ (69 mV ~ 109 mV) to the LINE IN jacks and check for 580 mV. (Minimum Input Level checks for the LINE inputs).

6-3-2. SPECIFIED LINE CONTROL SETTING

Specification:

Specified input level. -9 dB (274 mV)

9. Apply a 400 Hz signal at -9 dB (274 mV) to the LINE IN jacks.
10. Set the LINE controls to obtain a reading of 580 mV (-2.5 dB) on the VTVM. At this time, the physical position of the LINE controls indicates the Specified LINE Control Setting referred to in subsequent procedures.

IMPORTANT

After this setting is done, do not disturb the Specified Control Setting of the LINE controls until the remaining checks and adjustments are completed.

6-3-3. VU METER CALIBRATION —RECORD—

Specification. +3 VU (\square)

11. Adjust VR104/204 for +3 VU (\square) on the VU meter.

Preparations:

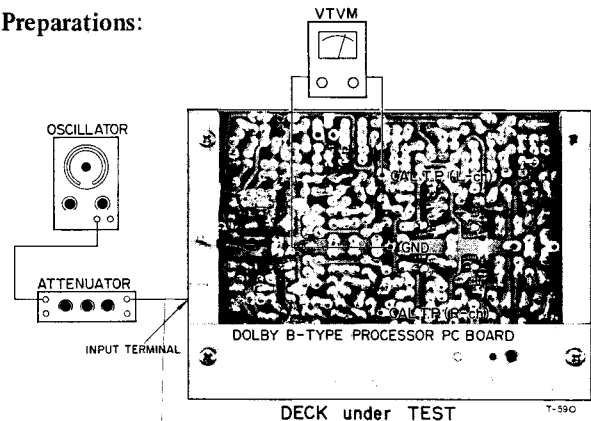

Fig. 6-9 Connection

Switch Setting:

BIAS	EQ	LIMITER	DOLBY NR	
—	—	—	IN	OUT

Control Setting:

OUTPUT: Specified Setting (See 6-2-2)
 LINE: Minimum Setting
 MIC: Minimum Setting

6-3-4. LED PEAK LEVEL INDICATOR CALIBRATION

12. Place DOLBY NR IN-OUT-IN/MPX switch to OUT position, adjust VR108 so that the PEAK level indicator lights as shown in Fig. 6-10, when a 400 Hz signal is applied at required level to the left channel LINE IN jack. Keep the right channel LINE IN jack disconnected from the AF oscillator.
13. For the right channel, repeat the above procedure except adjust VR208. Keep the left channel LINE IN jack disconnected from the AF oscillator.
14. After setting both channels, make sure the indicator reacts the same as above when required signal is simultaneously applied to both channels.

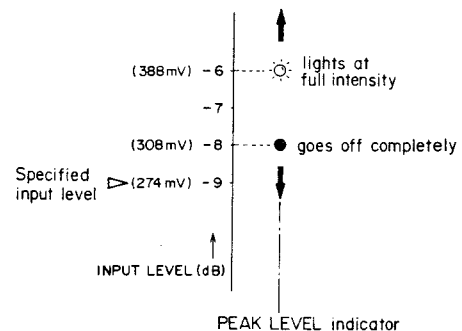

T-591

Fig. 6-10 LED Peak Level Indicator Setting

6-3-5. CHECKING OF DOLBY NR COPY-OUT-FM SWITCH FUNCTION

Specification:

When required input level is applied, Output level should be $-5 \text{ dB} \pm 2 \text{ dB}$

1. Load any recordable tape.
2. Place the deck in the RECORD-PAUSE mode.
3. Apply a 400 Hz signal at -9 dB (274 mV).
4. Make sure the VTVM indication is $-5 \text{ dB} \pm 2 \text{ dB}$ (345 mV \sim 548 mV).
5. If the VTVM indication is out of specification, adjust the DOLBY FM/COPY CAL controls (VR760/860) on the A-650 rear panel.
6. Change the input signal to 10 kHz and also check for $-5 \text{ dB} \pm 2 \text{ dB}$ on VTVM.
7. Set the DOLBY NR COPY-OUT-FM switch to FM.
8. Apply a 10 kHz signal at -17 dB (109 mV).
9. Confirm that the output level indicated on the VTVM is $-5 \text{ dB} \pm 2 \text{ dB}$.

NOTE

When the DOLBY NR COPY-OUT-FM switch is in COPY or FM position, the LINE and MIC controls have no control over the input signal and only the

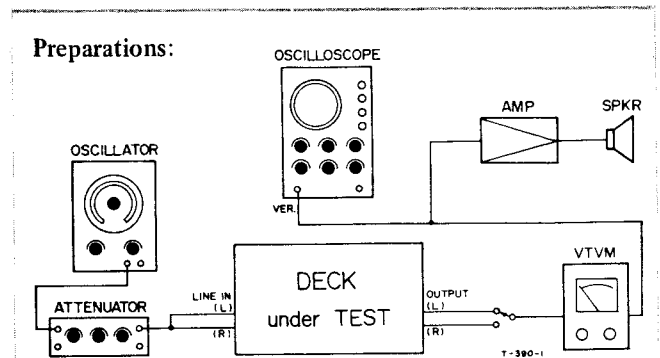

Fig. 6-11 Connection

Switch Setting:

BIAS	EQ	LIMITER	DOLBY NR	
-	-	-	OUT	COPY

Control Setting:

OUTPUT: Specified Setting (See 6-2-2)
 LINE: Specified Setting (See 6-3-2)
 MIC: Minimum Setting

DOLBY FM/COPY CAL controls (on the back panel) can adjust the input level. However, for the convenience of the following procedure, do not disturb the LINE and MIC control settings.

6-4. RECORDING PERFORMANCE

NOTE

1. Before making any adjustments of the recording circuit, be sure that all tests in the PLAYBACK and MONITOR performance sections have been accomplished. The preceding performance should be properly adjusted; otherwise record calibration would be inaccurate.
2. The adjustments and checks for Fe-Cr and Hi-Fi tapes usually may be omitted unless the technician wishes to confirm that they also are within specifications, except for the sections where these tape are designated.

6-4-1. BIAS TRAP ADJUSTMENTS

NOTE

The VTVM used in this procedure must have load impedance of 1M ohm or more.

1. Load any recordable tape.
2. Place the deck in the RECORD-PAUSE mode with no signal applied.
3. Adjust L101/201 for a minimum reading.
4. Change the VTVM connections to the CAL test point and ground. See Fig. 6-12.
5. Adjust L703/803 for minimum reading on the VTVM.

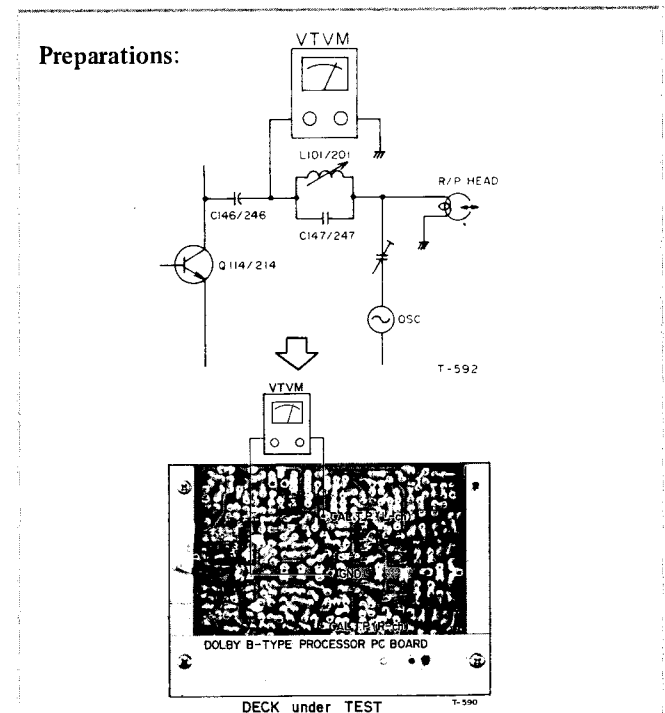

Fig. 6-12 Connection

Switch Setting:

BIAS	EQ	LIMITER	DOLBY NR	
-	-	-	-	-

Control Setting: Same as above section.

6-4-2. RECORD BIAS SETTING

CrO₂ TAPE

1. Load a TEAC MTT-505B test tape.
2. Adjust VC602/601 in a counter clockwise direction until the capacitor leaf springs open completely.
3. Apply and record two tone signals in turn; a 1 kHz signal and a 7 kHz signal, both at -42 dB (6.15 mV).
4. Rewind and play this recorded section and note the VTVM indication.
5. Turn VC602/601 clockwise slightly and record another section of tape.
6. Rewind over this section and play the tape again and note the VTVM indication.
7. Repeat this operation of recording, rewinding, playing, and adjusting until no difference in playback level between these two signals is obtained.

Fe-Cr TAPE

8. Set BIAS/EQ switches to position #2.
9. Load MTT-501 test tape.
10. Adjust VC604/603 counter clockwise until capacitor leaf springs open completely.
11. Connect a 1 kHz, -15 dB input signal.
12. Record a ten second section of tape, rewind and play that section and note VTVM indication.
13. Adjust VC604/603 slightly clockwise.
14. Repeat this operation of recording, rewinding, playing, and adjusting until the peak value on the VTVM is obtained.
15. After the preceding adjustment is done, install the MTT-504 tape.
16. Apply and record two tone signals alternately, a 1 kHz signal and a 7 kHz signal, both at -42 dB (6.15 mV).
17. Further adjust VC604/603 slightly until identical readings at both frequencies are found using the process of adjusting, recording rewinding and playing back the tape.

Hi-Fi TAPE

18. Load a TEAC MTT-501 test tape with the BIAS/EQ switches set to the "3" position and with the DOLBY NR IN-OUT-IN/MPX switch set to IN.
19. Apply and record 2 tone signals, in turn; a 400 Hz tone at -39 dB (8.69 mV) and a 10 kHz tone at -39 dB.
20. Rewind and play this recorded section.
21. Compare the differences between the output level of the 400 Hz signal and that of the 10 kHz signal.
22. The output level of the 10 kHz signal must be 4 dB above the 400 Hz signal level.
23. Adjust VC606/605 to achieve this, continuing the process of recording-rewinding-playing-adjusting.

Preparations:

Connection: See Fig. 6-11 on page 25.

Switch Setting:

BIAS	EQ	LIMITER	DOLBY NR	
1	1	OUT	OUT	OUT

Control Setting:

OUTPUT: Specified Setting (See 6-2-2)
 LINE: Specified Setting (See 6-3-2)
 MIC: Minimum Setting

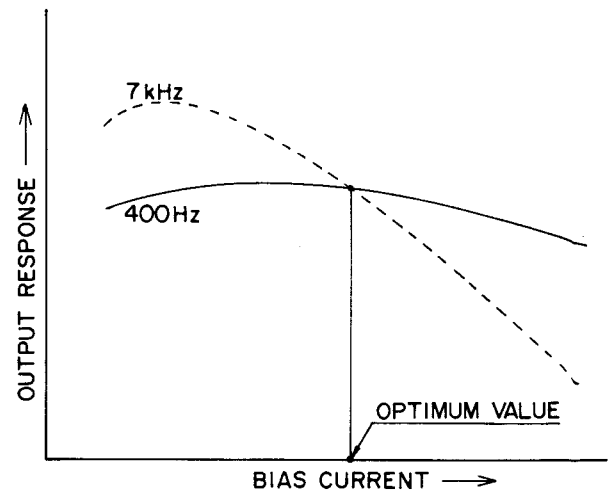

T-588

Fig. 6-13 Bias Adjustment (CrO₂ & Fe-Cr tape)

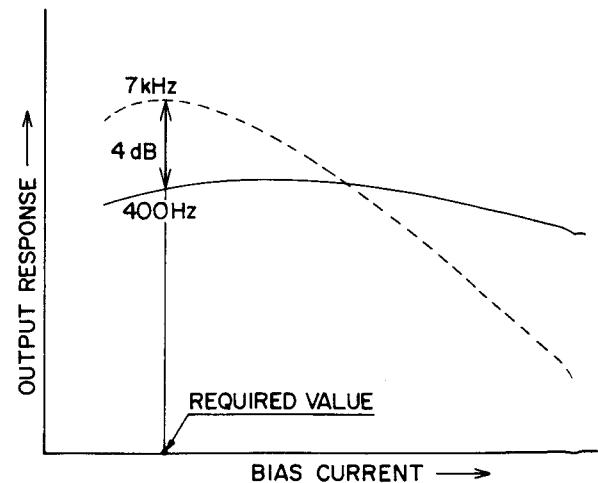

T-589

Fig. 6-14 Bias Adjustment (Hi-Fi tape)

6-4-3. RECORD LEVEL SETTING

CrO₂ TAPE

24. Load a TEAC MTT-505B test tape and set the BIAS/EQ switches to the "1" position.
25. Apply and record a 400 Hz test signal at -9 dB (274 mV).
26. Rewind and play this recorded section.
27. Adjust VR107/207 to obtain -5 dB (435 mV) at deck's output.
28. Continue the process of the recording-rewinding-playing-adjusting until this -5 dB is obtained.

Fe-Cr TAPE

29. Repeat the preceding procedure, with the following exceptions.

BIAS/EQ switches: "2" position
 Test tape: MTT-504
 Adjustments: VR106/206

Hi-Fi TAPE

30. Repeat the preceding procedure, with the following exceptions.

BIAS/EQ switches: "3" position
 Test tape: MTT-501
 Adjustments: VR105/205

6-4-4. DISTORTION CHECKS

Specification:

2.5% or less (w/ 3 types of tape)

CrO₂ TAPE

1. Load a TEAC MTT-505B test tape.
2. Apply and record a 400 Hz test tone at -12 dB (194 mV).
3. Rewind and play this recorded section.
4. Read the indicated value on the distortion analyzer.

Fe-Cr TAPE

5. Repeat the above procedure, with the following exceptions.

BIAS/EQ switches: "2" position
 Test tape: MTT-504

Hi-Fi TAPE

6. Repeat the above "CrO₂ TAPE" procedure, with the following exceptions.

BIAS/EQ switches: "3" position
 Test tape: MTT-501

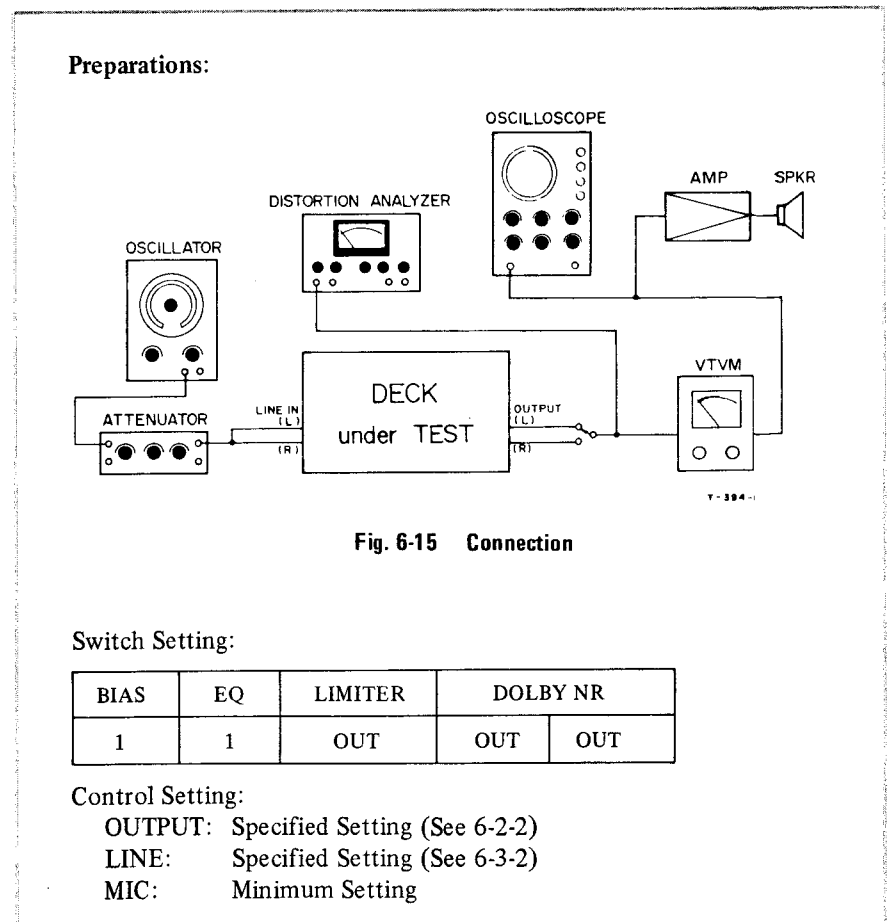

6-4-5. FREQUENCY RESPONSE –OVERALL–

CrO₂ TAPE

1. Load a TEAC MTT-505B test tape.
2. Apply and record a test signal from 30 Hz to 14 kHz at -42 dB (6.15 mV).
3. Rewind and play this recorded section.
4. Make sure the readings on the VTVM are within the response limits.
5. In case of any deviation in the high frequency range of the response limits, clean the heads and if this cleaning is ineffective adjust L750/850.

Fe-Cr TAPE

6. Repeat the above procedure, with the following exceptions.

BIAS/EQ switches: "2" position
 Test tape: MTT-504
 Adjustments: L751/851

Hi-Fi TAPE

7. Repeat the above procedure, with the following exceptions.

BIAS/EQ switches: "3" position
 Test tape: MTT-501
 Applied frequencies: 30 Hz ~ 12.5 kHz
 Adjustments: L752/852

Preparations:

Connection: See Fig. 6-11 on page 25.

Switch Setting:

BIAS	EQ	LIMITER	DOLBY NR	
1	1	OUT	OUT	OUT

Control Setting:

OUTPUT: Specified Setting (See 6-2-2)
 LINE: Specified Setting (See 6-3-2)
 MIC: Minimum Setting

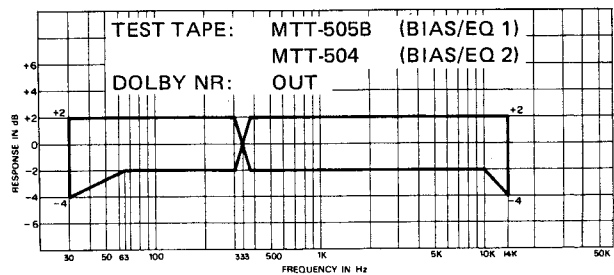

Fig. 6-16 Overall Frequency Response Limits (for BIAS/EQ 1, 2)

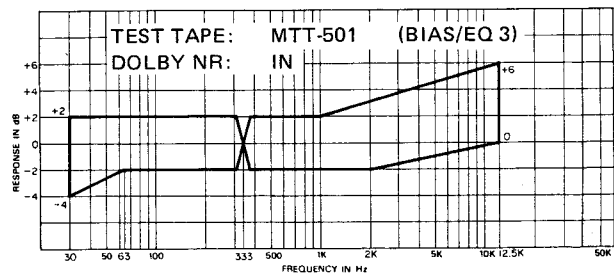

Fig. 6-17 Overall Frequency Response Limits (for BIAS/EQ 3)

6-4-6. SIGNAL TO NOISE RATIO –OVERALL–

Specifications:

CrO₂ & Fe-Cr tapes: 46 dB (minimum)
 Hi-Fi tape: 44 dB (minimum)

CrO₂ TAPE

1. Load a TEAC MTT-505B test tape.
2. Place the deck in the record mode for a few seconds with no signal applied.
3. Rewind and play this recorded (erased) section.
4. Read the indication on the VTVM.
5. The VTVM should indicate -51 dB minimum (2.18 mV maximum).
6. This -51 dB corresponds to the specified signal-to-noise ratio of 46 dB (minimum): the difference between the residual noise of -51 dB and the specified output level -5 dB (435 mV).

Preparations:

Connection: See Fig. 6-6 (B) on page 22.

Switch Setting:

BIAS	EQ	LIMITER	DOLBY NR	
1	1	OUT	OUT	OUT

Control Setting:

OUTPUT: Specified Setting (See 6-2-2)
 LINE: Specified Setting (See 6-3-2)
 MIC: Minimum Setting

Fe-Cr TAPE

7. Repeat the preceding procedure, except use the TEAC MTT-504 test tape and set BIAS/EQ switches to "2" position.
8. Requirement is the same as that for "CrO₂ TAPE".

Hi-Fi TAPE

9. Repeat the preceding "CrO₂ TAPE" procedure, except use the TEAC MTT-501 test tape and set BIAS/EQ switches to "3" position.
10. The VTVM should indicate -49 dB minimum (2.74 mV maximum).
11. This -49 dB corresponds to the specified signal-to-noise ratio of 44 dB (minimum): the difference between the residual noise of -49 dB and the specified output level -5 dB.

6-4-7. DOLBY NR EFFECT MEASUREMENT

Specifications:

- Variation from reference at 1 kHz: 4 dB to 7 dB
- Variation from reference at 10 kHz: 8 dB to 12 dB

CrO₂ TAPE

1. Load a TEAC MTT-505B test tape.
2. Apply and record a 1 kHz signal at -42 dB (6.15 mV).
3. Rewind and play this recorded section.
4. While playing the 1 kHz signal, read the indication of the output level on the VTVM with the DOLBY NR IN-OUT-IN/MPX switch at IN and OUT positions.
5. The output level should vary 4 dB to 7 dB between the IN and OUT positions. (The output level in the IN position should be lower than the OUT position.)
6. Repeat the above procedure changing the applied test signal to 10 kHz at -39 dB (8.69 mV).

Preparations:

Connection: See Fig. 6-11 on page 25.

Switch Setting:

BIAS	EQ	LIMITER	DOLBY NR	
1	1	OUT	OUT	OUT

Control Setting:

- OUTPUT: Specified Setting (See 6-2-2)
- LINE: Specified Setting (See 6-3-2)
- MIC: Minimum Setting

7. The variation should be 8 dB to 12 dB. (The output level in the IN position should be lower than in the OUT position).

6-4-8. PEAK LIMITER EFFICIENCY CHECKS

Specification: Limiter efficiency: 7 dB ± 2 dB

1. Load a TEAC MTT-501 test tape.
2. Apply and record a 400 Hz signal at -12 dB (194 mV) for several seconds.
3. Set LIMITER switch to IN.
4. Apply and record a 400 Hz signal at -2 dB (615 mV) to next portion of the tape for a while.
5. Rewind the tape to the starting point of the 400 Hz, -12 dB signal recorded portion.
6. Play the tape and compare the output level difference between the -12 dB recorded portion and the -2 dB recorded section.
7. The output level of -2 dB recorded portion should be 3 dB ± 2 dB higher than that of the -12 dB recorded portion.
8. Thus, when a -2 dB input level is applied with LIMITER switch IN, Peak Limiter circuit functions to

Preparations:

Connection: See Fig. 6-11 on page 25.

Switch Setting:

BIAS	EQ	LIMITER	DOLBY NR	
3	3	OUT	OUT	OUT

Control Setting:

- OUTPUT: Specified Setting (See 6-2-2)
- LINE: Specified Setting (See 6-3-2)
- MIC: Minimum Setting

9. This 7 dB ± 2 dB corresponds to Specified Limiter Efficiency.

6-4-9. ERASE EFFICIENCY

Specification: 65 dB (minimum)

NOTE

To measure erase efficiency, a 1 kHz narrow bandpass filter should be used. The test signal delivered from the AF oscillator should be tuned to the filter used.

Numbers in parentheses correspond to steps in Fig. 6-19.

1. Load a TEAC MTT-505B test tape.
2. Apply and record a 1 kHz signal at +1 dB (0.869 V) for several seconds. (1)
3. Rewind the tape to the mid-point of the recording and remove the signal from the LINE IN jacks. (2)
4. Place the deck in the record mode and record through this previously recorded portion with no input signal applied. (3)
5. Rewind the tape to the starting point of the 1 kHz signal recorded portion. (4)
6. Play the tape and read the indication on the VTVM to obtain the output level of both the unerased portion and the erased portion of the recorded section. (5)
7. Measure the output level differences between the 2 portions.

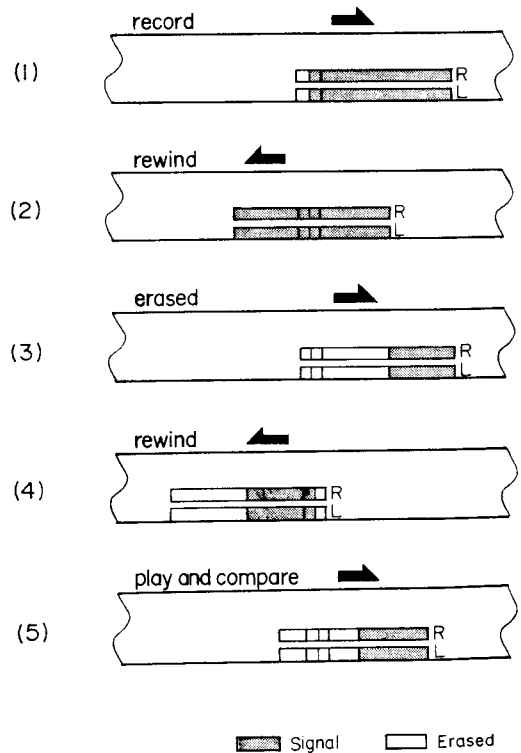
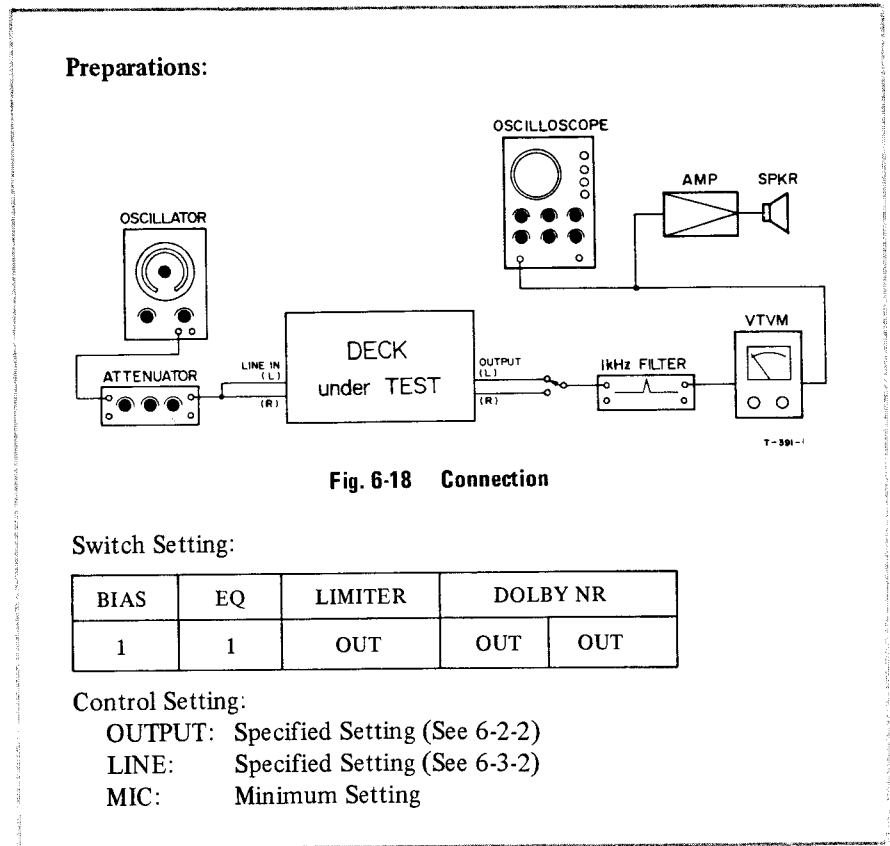

Fig. 6-19 Erase Efficiency Check Procedure

6-4-10. CHANNEL SEPARATION

Specification: 30 dB (minimum)

NOTE

To check channel separation (cross talk between channels), a 1 kHz narrow bandpass filter should be used. The test signal delivered from an AF oscillator should be tuned to the filter used.

Numbers in parentheses correspond to steps in Fig. 6-21.

1. Load a TEAC MTT-505B test tape.
2. Apply a 1 kHz test-tone at -9 dB (274 mV) into the left channel.
3. Place the deck in the record mode for about 30 seconds. (1)
4. Rewind the tape to the starting point of recording. (2)
5. Play the tape and measure the output level differences between the left and right channels. . . (3)

Preparations:

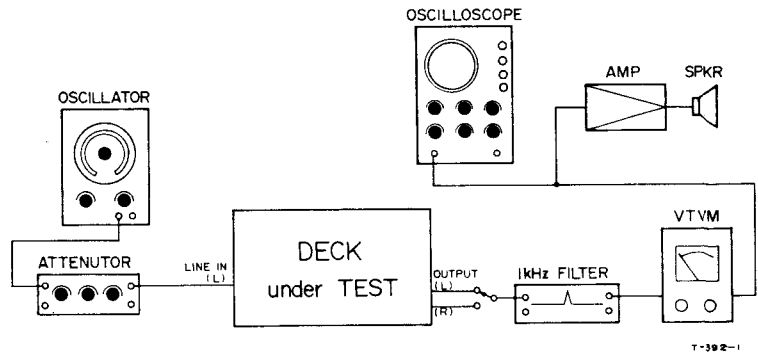

Fig. 6-20 Connection

Switch Setting:

BIAS	EQ	LIMITER	DOLBY NR	
1	1	OUT	OUT	OUT

Control Setting:

OUTPUT: Specified Setting (See 6-2-2)
LINE: Specified Setting (See 6-3-2)
MIC: Minimum Setting

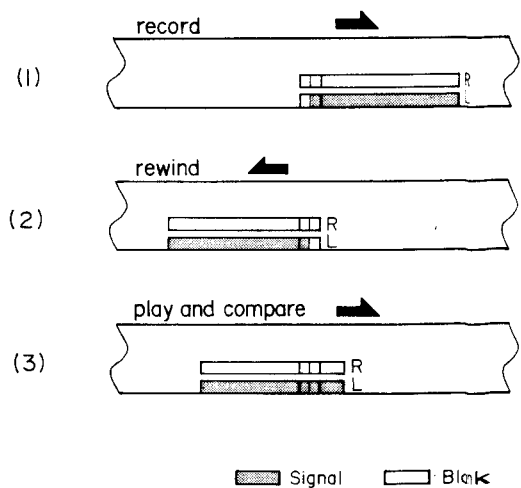

Fig. 6-21 Channel Separation Check Procedure

6-4-11. ADJACENT TRACK CROSSTALK MEASUREMENT

Specification: 40 dB (minimum)

NOTE

The tape must be completely erased prior to this procedure. Preferably use bulk erased tape.

Numbers in parentheses correspond to steps in Fig. 6-23.

1. Load a TEAC MTT-505B test tape.
2. Apply a 100 Hz test signal at -9 dB (274 mV).
3. Place the deck in the record mode for about 30 seconds. (1)
4. Rewind the tape to the starting point of recording. (2)
5. Play the tape and measure the output level of the recorded portion. Note this reading for temporary reference level for the following measurements. (3)
6. Remove the test tape, turn it over and replace it in the deck. (4)
7. Play the tape back and read the output level. (5)
8. Get the differences between this reading and the reading previously measured for the 100 Hz signal.

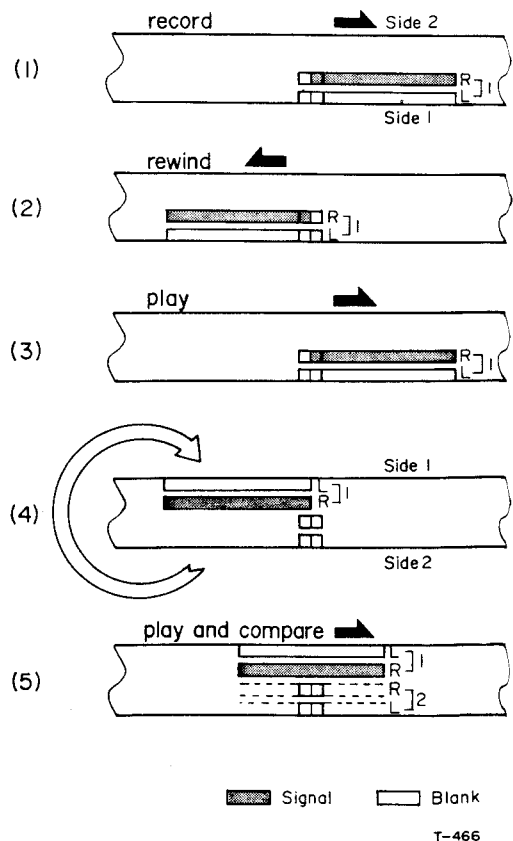
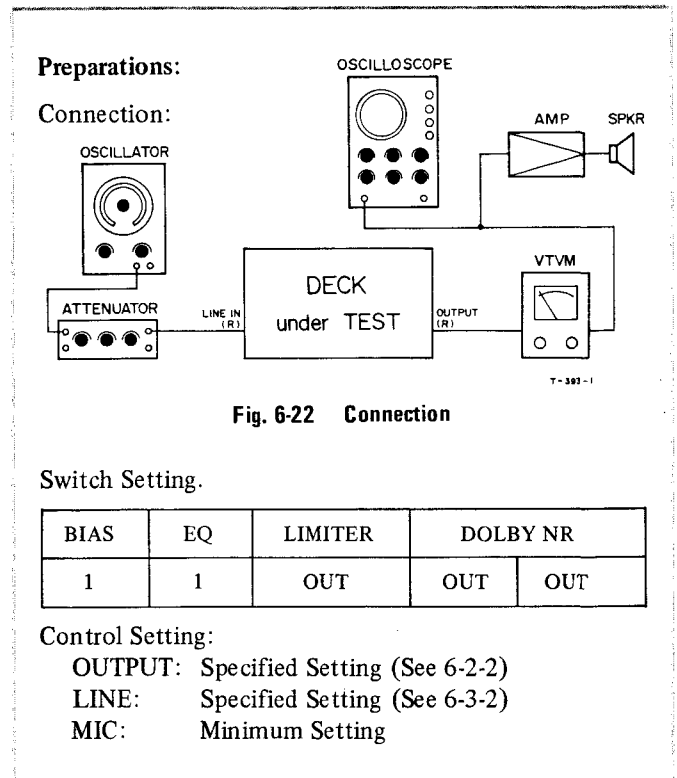
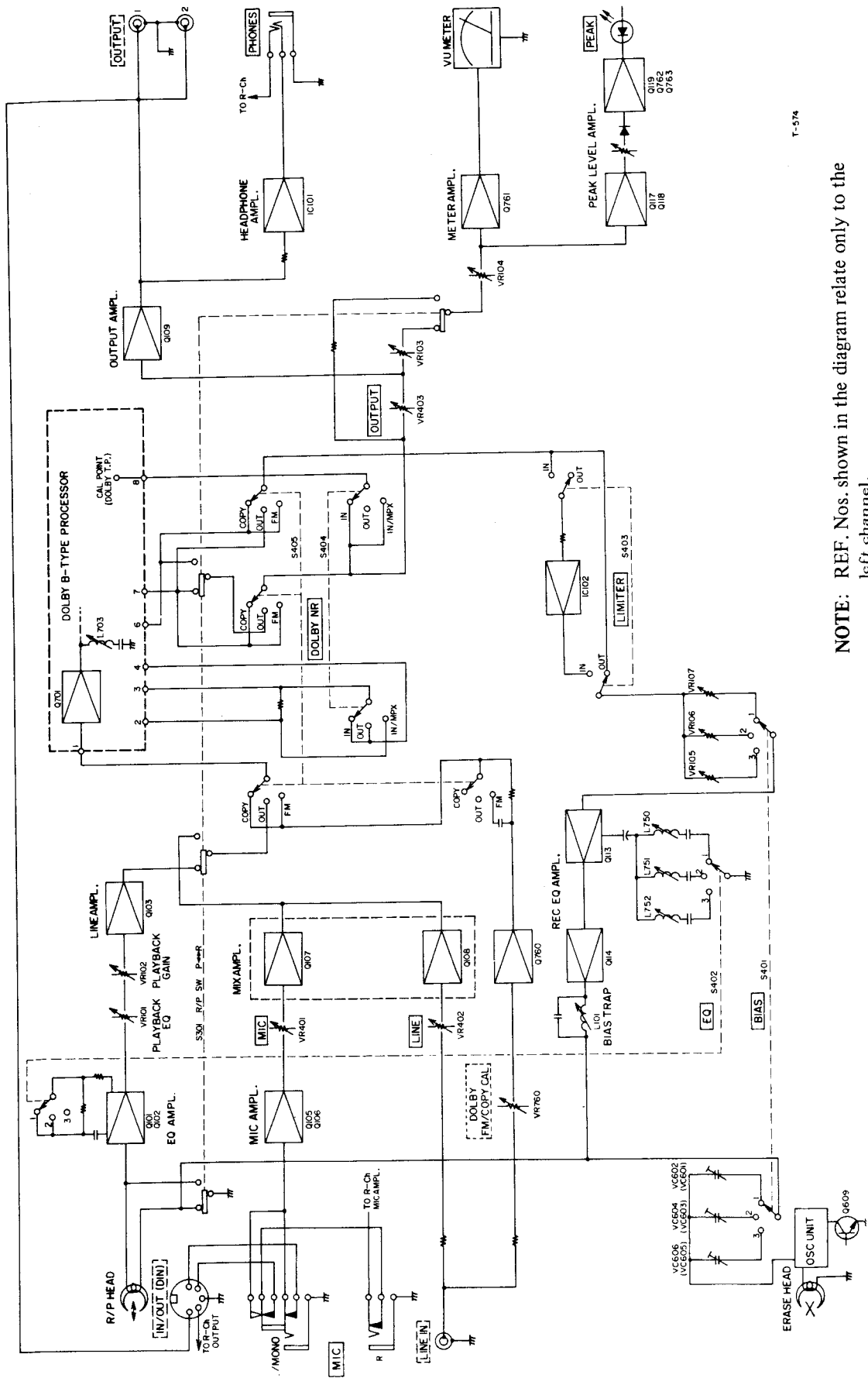

Fig. 6-23 Adjacent Track Crosstalk Measurement Procedure

7. BLOCK DIAGRAM



T-574

NOTE: REF. Nos. shown in the diagram relate only to the left channel.

8. LEVEL DIAGRAM

PLAYBACK SECTION

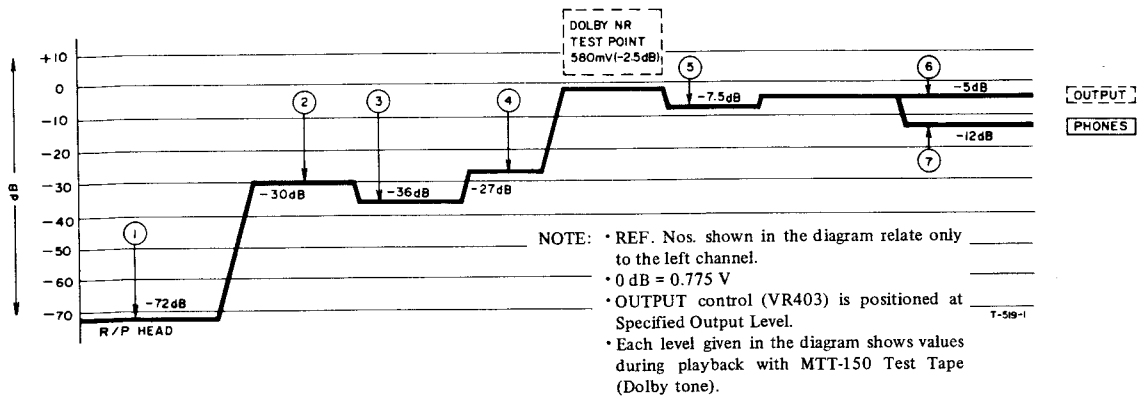
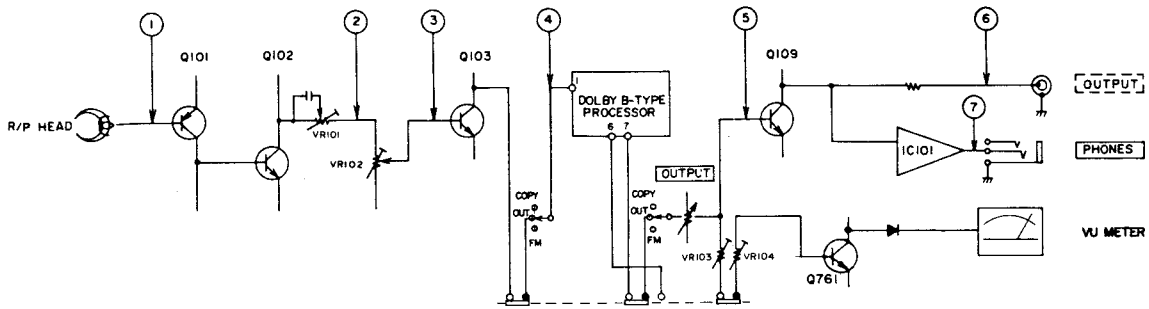

RECORDING SECTION

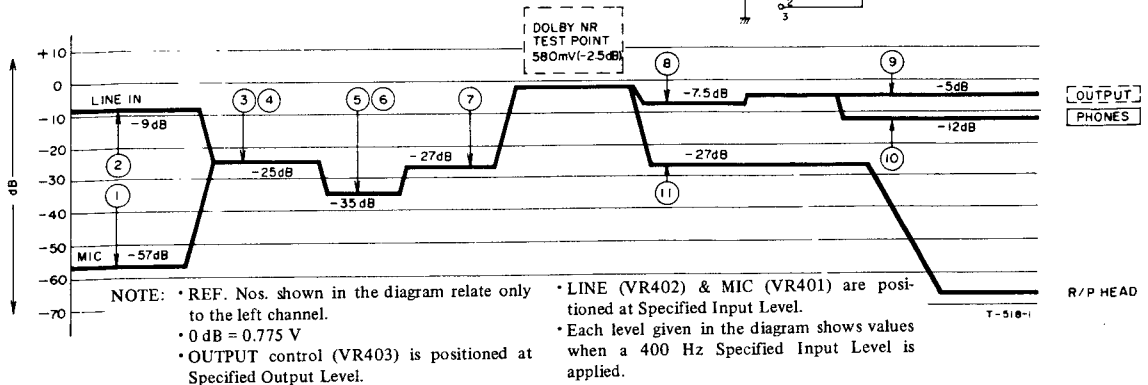
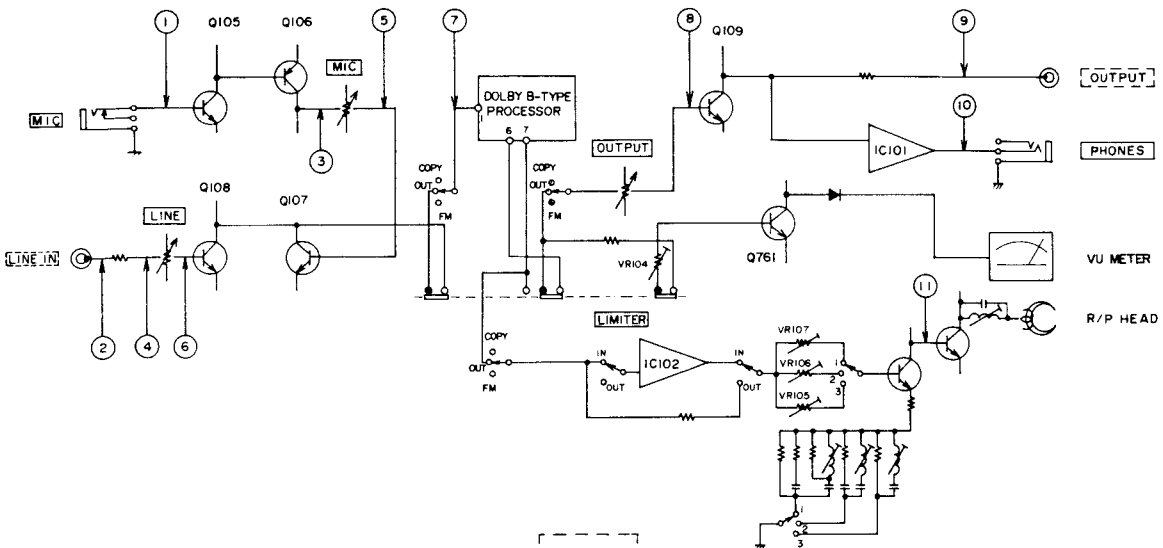

9. TROUBLE-SHOOTING

NOTE

REF. No's indicated in the following table refer to the left channel.
For the right channel REF. No. identification, see schematic
Diagram.

TAPE TRANSPORT SECTION

1. Fuse blows when POWER is switched ON.
 - Defective Power Transformer
2. Auto End-stop will not work in Play and/or Fast Wind.
 - Defective Transistor Q529
 - Defective Diode D533
 - Defective Capacitor C512
 - Defective Resistor R564
 - Defective Parts associated with Hall Effect Element
3. Tape winds onto Capstan Shaft
 - Defective Pinch Roller
 - Defective Take-up Reel Table Ass'y
 - Idler slipping
 - Tape path wrong (improper Tape Guide position, bad Head mounting)
4. Excessive Wow and Flutter
 - Defective Pinch Roller, Pinch Roller pressure incorrect
 - Capstan Belt stretched or oily
5. Capstan does not rotate
 - Capstan Belt off
 - Defective Motor
 - Defective Switch S509
6. Index Counter will not count
 - Counter reset button not fully depressed.
 - Counter Belt off

AMPLIFIER SECTION

1. No sound in playback mode
Noise (hum or clicking noise) appear when touching head wires.
 - Poor soldering of head terminations
 - Defective HeadSound can be heard during recording
 - Defective Switch S301
 - Defective Transistor Q101, Q102, Q103
 - Defective Parts associated with parts indicated aboveSound cannot be heard during recording
 - Defective Transistor Q101, Q102, Q103, Q109
 - Defective Dolby NR Circuit
 - Defective Parts associated with parts indicated above
2. VU Meter will not indicate in playback mode
 - Defective VU Meter
 - Defective Transistor Q761
 - Defective Semi-fixed Resistor VR103, VR104
 - Defective Parts associated with parts indicated above
3. Loss of high frequencies in playback mode
High frequencies too low
 - Defective Transistor Q102
 - Playback equalizer circuit wrongHigh frequencies are several dB below specified response limits
 - Head dirty or defectiveLoss of high frequencies including level variation
 - Improper head-to-tape contact
 - Unstable functioning of tape transport mechanism
4. Poor playback signal-to-noise ratio
Excessive hum - reduced when changing Power Transformer
 - Defective Power TransformerExcessive white noise (hiss and circuit noise)
 - Defective Head
 - Defective Transistor Q101, Q102
 - Associated circuitry of Transistor Q101, Q102Wave form varies continuously
 - Defective Transistor Q101, Q102
 - Defective Capacitor C102, C108
 - Defective Parts associated with parts indicated above
5. Does not record
Can record when changing Bias Switch setting
 - Defective Bias Switch
 - Defective Trimmer Capacitors VC602, VC60+, VC606
 - Defective Parts associated with parts indicated aboveCannot erase, also
 - Bias Oscillator Ass'y faultyCan erase - sound from record monitor mode is normal
 - Head dirty
 - Defective Switch S301
 - Defective Circuitry of IC102, Q113, Q114

A-650

Stereo Cassette Deck with Dolby System

TEAC.

TEAC CORPORATION

3-7-3, NAKA-CHO, MUSASHINO, TOKYO PHONE: (0422) 53-1111

TEAC CORPORATION OF AMERICA

7733 TELEGRAPH ROAD, MONTEBELLO, CALIFORNIA 90640 PHONE: (213) 726-0303

TEAC HONGKONG LIMITED

FLAT 78, PORTLAND HOUSE, 7TH FLOOR, BLOCK C, No. 41-D, MA TAU WE ROAD,
KOWLOON, HONG KONG PHONE: 359071-4

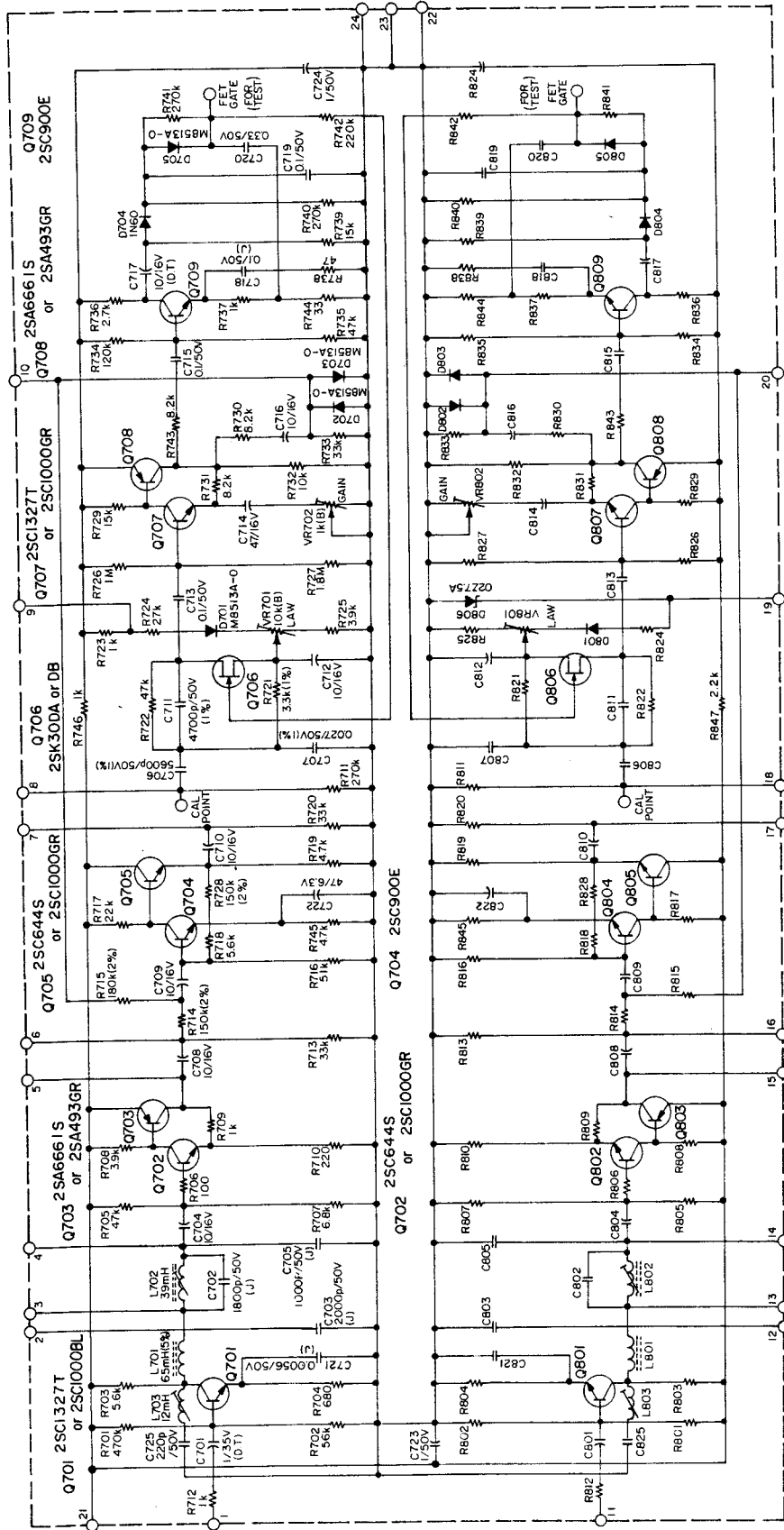

NOTES

1. ALL RESISTORS ARE 1% WATT, 5% UNLESS MARKED OTHERWISE. RESISTOR VALUES ARE IN OHMS (K=1,000 OHMS, M=1,000,000 OHMS).
2. ALL CAPACITOR VALUES ARE IN MICROFARADS (P=PICTOFARADS).

**DOLBY B-TYPE
PROCESSOR**
MODEL NO. **A-650**
SHEET NO.

REVISION	DATE	CHANGE NO.
1	12/76	0476
2		
3		
4		
5		
6		

TEAC CORPORATION

TEAC®

A-650

Stereo Cassette Deck with Dolby System

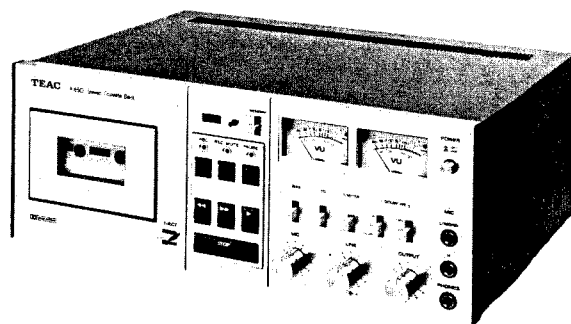

PARTS LIST

PARTS ORDERING INFORMATION

Spare parts are available through your nearest TEAC Authorized Service Center or directly from the TEAC office, the address of which is written on the back cover. When ordering parts, always include the following information:

- | | |
|--------------|--------------------|
| 1. MODEL | 4. DESCRIPTION |
| 2. REF. NO. | 5. UNIT SERIAL NO. |
| 3. PARTS NO. | 6. MANUAL CODE NO. |

NOTICE REGARDING PARTS ORDERS

1. Do not order by only REF. NO.
2. In some instances, individual minor parts are not available. In such a case, the entire assembly including the part requested will be sent to you.
3. Parts are identical between the different modes with the exceptions as coded by the designations in the REMARKS column.
4. PC Boards shown viewed from foil side.
5. Parts marked with *require longer delivery time than regular parts.

TABLE OF CONTENTS

EXPLODED VIEWS AND PARTS LIST SECTION

EXPLODED VIEW-1	3
EXPLODED VIEW-2	4,5,10
EXPLODED VIEW-3	6,7
EXPLODED VIEW-4	8,9,10

PC BOARD SECTION

1. RECORD/PLAYBACK AMPL.	11,16
2. CONTROL PC BOARD	12,18
3. DOLBY B TYPE PROCESSOR	13,19
4. POWER SUPPLY	14,20
5. INPUT-OUTPUT PC BOARD	15,21
6. LEVER SWITCH PC BOARD	15,21
7. MUTING PC BOARD	16,22
8. VU LEVEL METER PC BOARD	16,22

INCLUDED ACCESSORIES	22
ASSEMBLING HARWARE CODING LIST	23

1. EXPLODED VIEWS AND PARTS LIST

EXPLODED VIEW-1

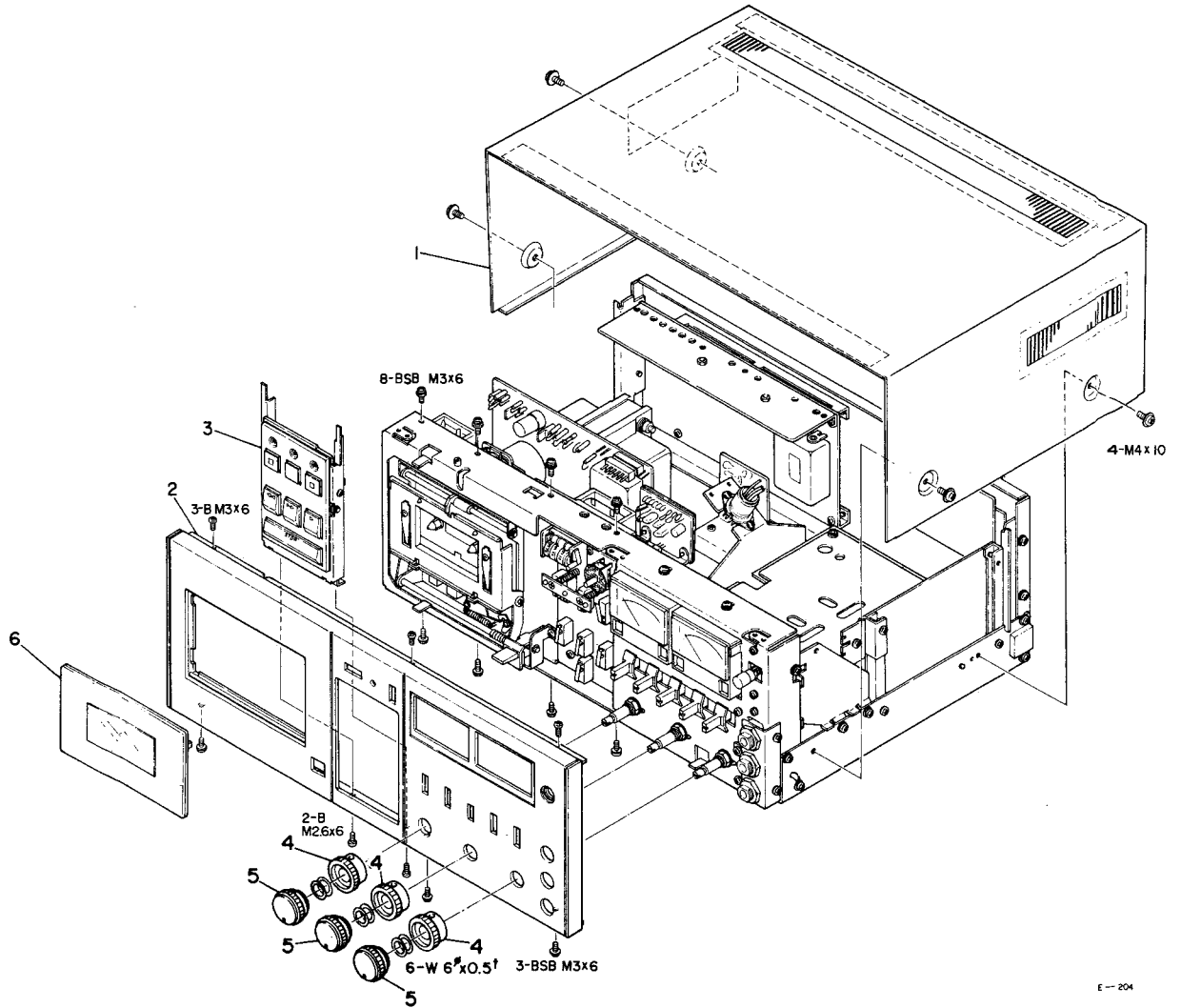

PARTS LIST-1

REF. NO.	PARTS NO.	DESCRIPTION	REMARKS
1 - 1	* 55021021	Cabinet Assy, Top	
1 - 2	* 55020961	Panel Assy, Front	JAPAN
	* 55020990	Panel Assy, Front	All except JAPAN
1 - 3	* 55020982	Button Ass'y	Part of above ass'y
1 - 4	55341950	Knob, B	
1 - 5	55341940	Knob, A	
1 - 6	55021011	Cover Assy, Cassette Holder	

EXPLODED VIEW-2

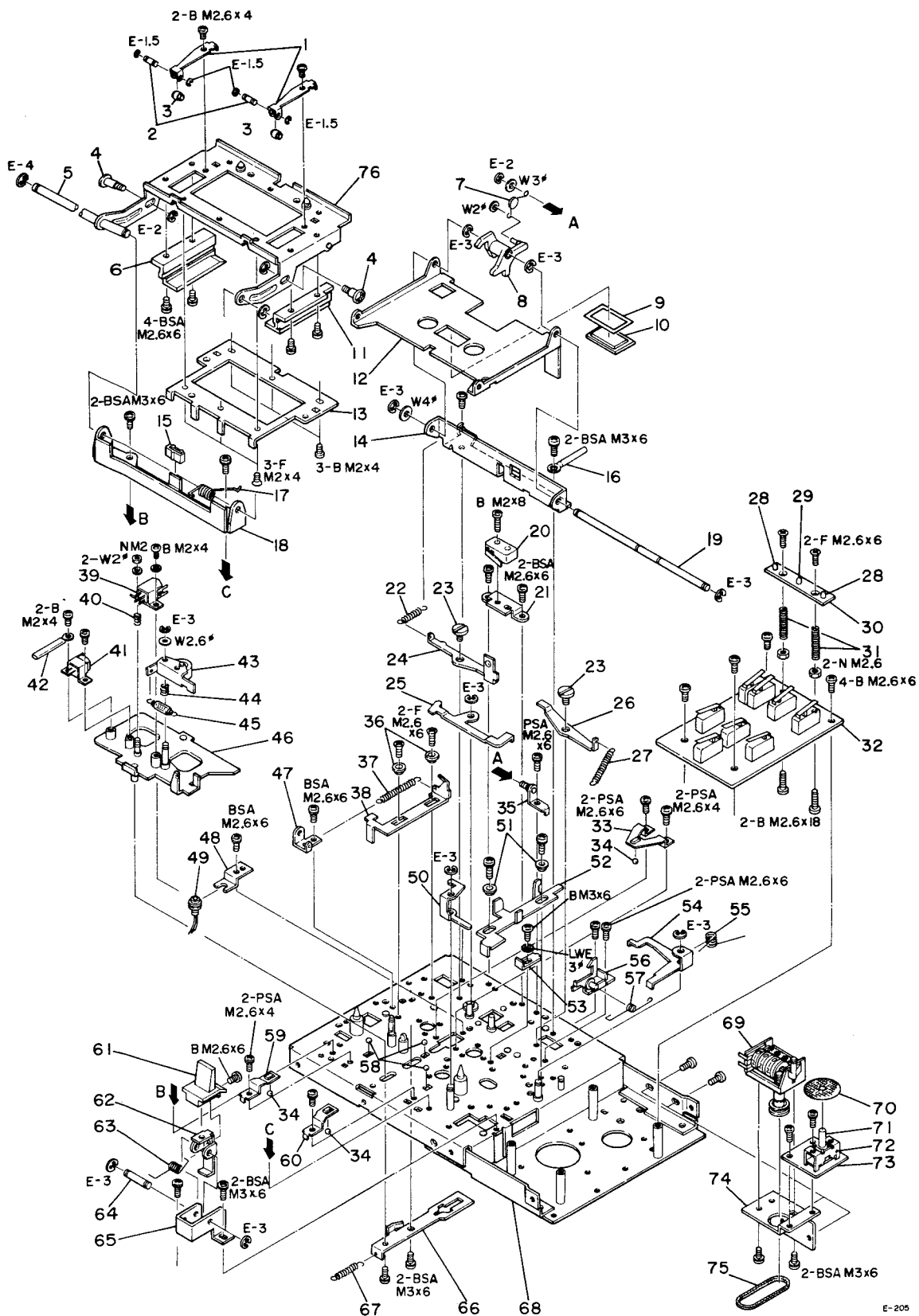

E-205

PARTS LIST-2

REF. NO.	PARTS NO.	DESCRIPTION	REMARKS
2 - 1	55546150	Plate Spring, Cassette Guide	
2 - 2	55443700	Shaft, Guide Roller	
2 - 3	55342630	Roller, Guide; Cassette	
2 - 4	55443641	Screw, Cassette Holder	
2 - 5	* 55443580	Shaft, Holder Bracket; F	
2 - 6	55342560	Guide, Cassette; L	
2 - 7	55240260	Spring, Arm	
2 - 8	55342570	Arm, Cassette Holding	
2 - 9	55546920	Contacting Paper, Cover	
2 - 10	55342460	Cover, Lamp	
2 - 11	55342550	Guide, Cassette; R	
2 - 12	55546021	Holder, Cassette; L	
2 - 13	55330471	Plate, Cassette Guide	
2 - 14	* 55546130	Bracket, Cassette Holder; R	
2 - 15	* 55342590	Cushion	
2 - 16	* 55810380	Retainer, Cords; A	
2 - 17	55240350	Spring, Cassette Holder; R	
2 - 18	* 55546410	Bracket, Cassette Holder; F	
2 - 19	* 55443590	Shaft, Cassette Holder; R	
2 - 20	50446600	Switch, Micro	
2 - 21	* 55546250	Bracket, Micro Switch	
2 - 22	55240360	Spring, Cassette Pushing Lever	
2 - 23	* 55443631	Screw, Lever	
2 - 24	* 55546300	Lever, Cassette Pushing	
2 - 25	* 55546860	Lever, Relay	
2 - 26	* 55546210	Lever, Arm Kick	
2 - 27	55240340	Spring, Eject Lever	
2 - 28	51430470	LED (Red)	
2 - 29	51430480	LED (Orange)	
2 - 30	* 51672850	PC Board, LED	
2 - 31	* 55240431	Spring, LED	
2 - 32	* 51682840	PC Board Assy, Operating Section	
	50446320	Switch, Micro (8 used)	
2 - 33	55546160	Plate Spring, M	
2 - 34	55400550	Steel Ball 2 #	
2 - 35	* 55043130	Holder Assy, Arm Spring	
2 - 36	* 55443620	Spacer, Record Preventing Lever	
2 - 37	55240400	Spring, Record Preventing Lever	
2 - 38	* 55546230	Lever, Record Preventing	
2 - 39	50660190	Head, Record/Playback	
2 - 40	55200021	Spring, Head Adjust.	
2 - 41	50663070	Head, Erase	
2 - 42	* 50831921	Retainer, Leads	
2 - 43	55000033	Pinch Roller Assy	
2 - 44	55200010	Spring, Guide	
2 - 45	55200030	Spring, Pinch Roller	
2 - 46	55042820	Plate Assy, Head Base	
2 - 47	* 55546040	Plate, Record Selector	
2 - 48	* 55546380	Holder, Lamp	
2 - 49	50414660	Lamp	
2 - 50	* 55546280	Lever, Pause; B	
2 - 51	* 55443610	Spacer, Edject Lever	
2 - 52	* 55546331	Lever, Edject	
2 - 53	* 55500070	Bracket, Stoper; Head Base Plate	
2 - 54	55546370	Lever, Edject Preventing	
2 - 55	55240290	Spring, Edject Preventing Lever	
2 - 56	* 55042810	Lock Lever Assy	
2 - 57	55240280	Spring, Lock Lever	
2 - 58	55400560	Steel Ball, 3#	
2 - 59	55500040	Plate Spring, Left	
2 - 60	55500050	Plate Spring, Right	
2 - 61	* 55342511	Knob, Edject	
2 - 62	* 55546321	Arm, Edject	
2 - 63	55240410	Spring, Edject Arm	
2 - 64	* 55443670	Shaft, Edject Arm	
2 - 65	* 55546340	Bracket, Edject Arm	

(Continued on page 10.)

PARTS LIST-3

REF. NO.	PARTS NO.	DESCRIPTION	REMARKS
3 - 1	* 55546690	Shield Paper, PC Board	
3 - 2	55043080	Motor Assy, Capstan	
3 - 3	* 55810380	Retainer, Cords; A	
3 - 4	* 55546180	Bracket, PC Board	
3 - 5	* 55546350	Plate, Mount.; Motor	
3 - 6	* 55042990	Shaft Assy, Pulley	
3 - 7	51682380	PC Board Assy, Hall-effect Element	
3 - 8	55042980	Pulley Assy, Counter Relay	
3 - 9	55043090	Motor Assy, Fast Wind	
3 - 10	* 55043010	Plate Assy, Motor Base	
3 - 11	55240321	Spring, Tension Arm	
3 - 12	55043020	Arm Assy, Tension	
3 - 13	* 55546290	Plate, Fast Wind Arm	
3 - 14	55042850	Idler Assy, Fast Wind	
3 - 15	* 55443650	Spacer, Fast Wind Arm	
3 - 16	55400550	Steel Ball, 2	
3 - 17	51682811	PC Board Assy, Control	
3 - 18	* 51220030	Connector, Socket; 6P	
3 - 19	51630100	Solenoid, A	
3 - 20	* 55342540	Bracket, Solenoid	
3 - 21	* 55342610	Flywheel Bearing	
3 - 22	* 55342600	Thrust Screw	
3 - 23	* 55043040	Plate Assy, Flywheel Bearing	
3 - 24	51630120	Solenoid, C	
3 - 25	55240470	Spring, Solenoid	
3 - 26	* 55546270	Lever, Brake Release	
3 - 27	55300112	Brake Shoe	
3 - 28	* 55042970	Plate Assy, Brake Solenoid	
3 - 29	55042840	Reel Table Assy, Supply	
3 - 30	55042830	Reel Table Assy, Takeup	
3 - 31	55342530	Belt, Counter; L	
3 - 32	* 55042960	Plate Assy, Brake	
3 - 33	55240310	Spring, Brake	
3 - 34	* 55042950	Holder Assy, Main Lever	
3 - 35	* 55342620	Lever, Main	
3 - 36	55546110	Plate Spring, Pressure	
3 - 37	* 55546240	Bracket, Micro Switch	
3 - 38	50446290	Switch, Micro	
3 - 39	* 50452531	Terminal Strip, 2L-3P	
3 - 40	55240330	Spring, Pause Lever	
3 - 41	* 55546310	Lever, Pause	
3 - 42	* 55443600	Cylinder, Oil Damper	
3 - 43	55240300	Spring, Damper	
3 - 44	* 55443710	Shaft, Damper	
3 - 45	* 55546140	Bracket, Damper	
3 - 46	* 55342580	Lever, Pause Kick	
3 - 47	* 55443660	Shaft, Pause Kick	
3 - 48	50446540	Switch, Micro	
3 - 49	* 55544350	Spacer, Insulator; B	
3 - 50	* 55546360	Bracket, Micro Switch	
3 - 51	* 55546260	Plate, Shaft Retaining	
3 - 52	51630110	Solenoid, B	
3 - 53	* 50438390	Connector, Socket; 16P	
3 - 54	* 50436610	Connector, Plug; 16P	
3 - 55	* 55546200	Bracket, Connector	
3 - 56	* 55500520	Cushion	
3 - 57	* 55000080	Lever Assy, Idler; A	
3 - 58	* 55000090	Lever Assy, Idler; B	
3 - 59	55001040	Idler Assy	
3 - 60	55200110	Spring, Idler Lever; B	
3 - 61	55341780	Belt, Capstan Drive	
3 - 62	55000482	Capstan Drive Assy	
3 - 63	* 55341300	Washer, Oil Retaining	
3 - 64	55500310	Washer, Thrust	

EXPLODED VIEW-4

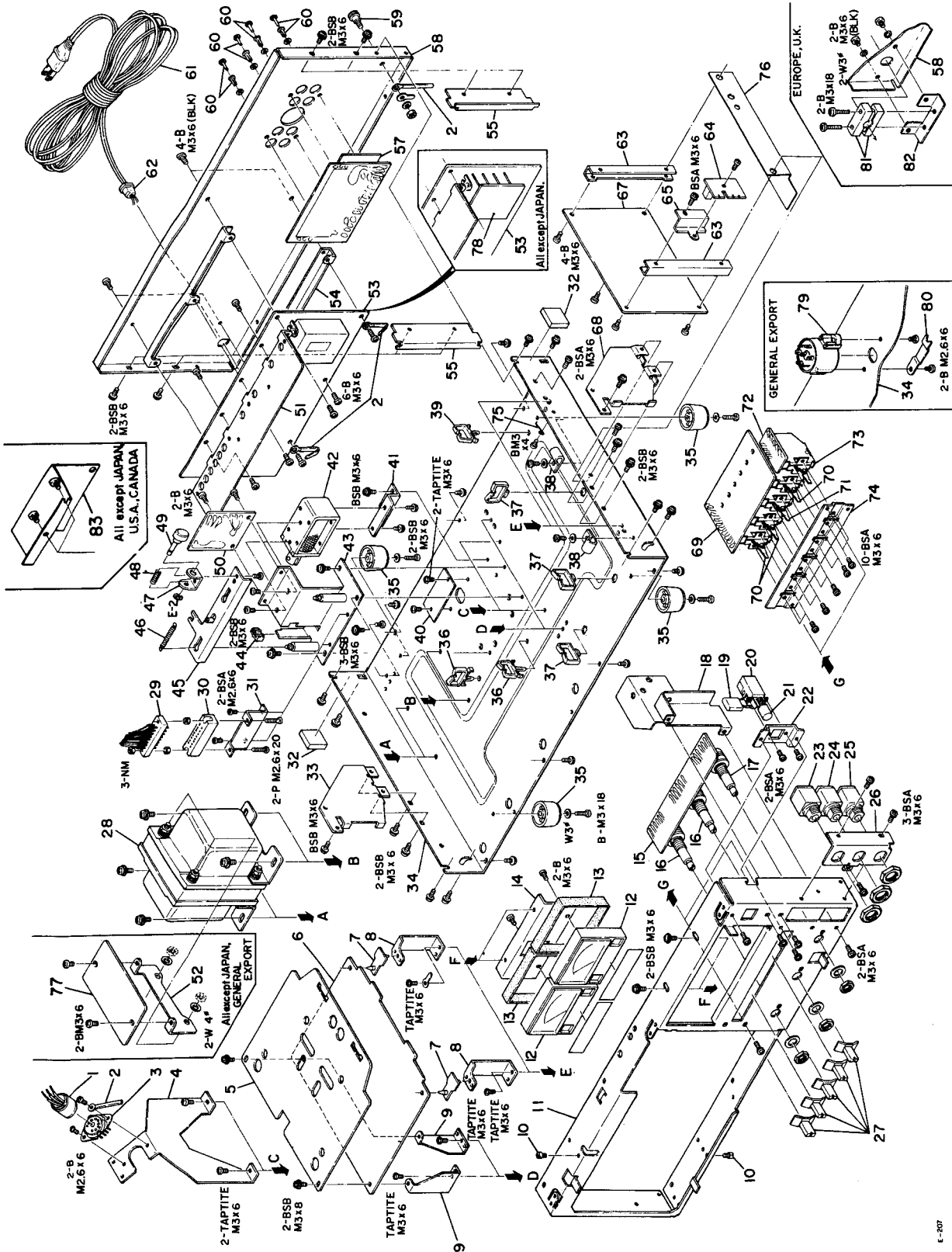

PARTS LIST-4

REF. NO.	PARTS NO.	DESCRIPTION	REMARKS
4 - 1	* 50432740	Connector, Plug; 9P	
4 - 2	* 55810380	Retainer, Cords; A	
4 - 3	* 50435040	Connector, Socket; 9P	
4 - 4	* 55530930	Plate, Socket	
4 - 5	* 55546681	Shield Paper, Record/Playback PC Board	
4 - 6	51682773	PC Board Assy, Record/Playback Ampl.	JAPAN
	51683652	PC Board Assy, Record/Playback Ampl.	All except JAPAN
4 - 7	* 50333110	Hinge, PC Board	
4 - 8	* 55546590	Bracket, PC Board; B	
4 - 9	* 55546600	Bracket, PC Board; C	
4 - 10	* 55341960	Screw, Guide	
4 - 11	* 55510100	Chassis, Front	
4 - 12	51650230	Meter, Peak	JAPAN
	51650240	Meter, VU	All except JAPAN
4 - 13	* 50939110	Protective Frame	
4 - 14	* 55546531	Plate, Meter	
4 - 15	* 51672870	PC Board, Var. Res.	
4 - 16	* 51500900	Var. Res., 100k ohm A x 2	
4 - 17	* 51500910	Var. Res., 20k ohm A x 2	
4 - 18	* 55043390	Plate Assy, Shield; B	
4 - 19	50529050	Spark Killer, 400V AC 0.1 mfd + 120 ohm	JAPAN
	50529060	Spark Killer, 150V AC 0.033 mfd + 120 ohm	U.S.A., CANADA
	51529070	Spark Killer, 400V AC 0.01 mfd + 300 ohm	GENERAL EXPORT
	50529080	Spark Killer, 4700 pfd	EUROPE, U.K., AUSTRALIA
4 - 20	51340090	Switch, Power	All except EUROPE, U.K.
	51340190	Switch, Power	EUROPE, U.K.
4 - 21	55400540	Knob, Power Switch	All except EUROPE, U.K.
	* 55444280	Knob, Power Switch	EUROPE, U.K.
4 - 22	* 55546522	Plate, Power Switch	
4 - 23	51240270	Jack, Phone; Single w/Switch	
4 - 24	51240250	Jack, Phone; Single	
4 - 25	51240260	Jack, Phone; 3 cond.	
4 - 26	* 55546541	Plate Assy, Jack	
4 - 27	55043060	Knob Assy, Lever Switch	
4 - 28	* 51520771	Transformer, Power	JAPAN
	* 51520880	Transformer, Power	U.S.A., CANADA
	* 51520890	Transformer, Power	GENERAL EXPORT
	* 51520900	Transformer, Power	EUROPE, U.K., AUSTRALIA
4 - 29	* 50436610	Connector, Plug; 16P	
4 - 30	* 50438390	Connector, Socket; 16P	
4 - 31	* 55546200	Bracket, Connector	
4 - 32	* 55546970	Felt	
4 - 33	* 55546470	Plate, L	
4 - 34	* 55510090	Chassis, Main	
4 - 35	* 55040290	Mount Foot	
4 - 36	* 50333100	Clamp, Wire; 14 mm	
4 - 37	* 50333090	Clamp, Wire; 20 mm	
4 - 38	* 50276290	Clamp, Wire, B	
4 - 39	* 50332580	Clamp, Wire, E	
4 - 40	* 55546490	Plate, Selector Mask	JAPAN, U.S.A., CANADA, AUSTRALIA
4 - 41	* 55546770	Plate, Solenoid; D	
4 - 42	51630130	Solenoid, D	
4 - 43	* 55043070	Bracket Assy, Solenoid	
4 - 44	55342590	Cushion	
4 - 45	* 55546620	Arm, Record/Playback Select Switch	
4 - 46	55240450	Spring, Switch	
4 - 47	* 55546630	Bracket, Switch Actuator; B	
4 - 48	55240460	Spring, Stud	
4 - 49	* 55341981	Stud, Switch Pushing	
4 - 50	51682881	PC Board Assy, Muting	
4 - 51	* 55530901	Heat Sink	
4 - 52	* 55547550	Bracket, Fuse PC Board	All except JAPAN, GENERAL EXPORT
4 - 53	51682781	PC Board Assy, Power Supply	JAPAN
	51683600	PC Board Assy, Power Supply	All except JAPAN
4 - 54	* 55546610	Bracket, PC Board; E	
4 - 55	* 55546750	Plate, Rear Chassis	

(Continued on page 10.)

PARTS LIST-2 (Continued from page 5.)

REF. NO.	PARTS NO.	DESCRIPTION	REMARKS
2 - 66	* 55546220	Plate, Head Base	
2 - 67	55240270	Spring, Head Base	
2 - 68	* 55020930	Chassis Assy	
2 - 69	55342650	Counter, Index	
2 - 70	55545040	Mask, Lever Switch	
2 - 71	55440400	Knob, Lever Switch; C	
2 - 72	50447450	Switch, Lever	
2 - 73	* 51672860	PC Board, Memory Switch	
2 - 74	* 55546190	Bracket, Counter Assy	
2 - 75	55342520	Belt, Counter; S	
2 - 76	55030361	Holder Assy, Cassette; U	

PARTS LIST-4 (Continued from page 9.)

REF. NO.	PARTS NO.	DESCRIPTION	REMARKS
4 - 56	* 51682800	PC Board Assy, Input-Output	JAPAN
	* 51682891	PC Board Assy, Input-Output	All except JAPAN
4 - 57	51260200	Terminal Assy	
4 - 58	* 55520900	Chassis, Rear	JAPAN
	* 55520920	Chassis, Rear	U.S.A., CANADA, GENERAL EXPORT, AUSTRALIA
	* 55521250	Chassis, Rear	EUROPE, U.K.
4 - 59	* 50454071	Terminal, Grand	All except EUROPE, U.K.
4 - 60	55341180	Push Rivet	
4 - 61	* 51280270	Cord, AC Power	JAPAN, GENERAL EXPORT
	* 50471661	Cord, AC Power	U.S.A., CANADA
	* 51280180	Cord, AC Power	EUROPE
	* 51280310	Cord, AC Power	AUSTRALIA
	* 51280360	Cord, AC Power	U.K.
	* 50471652	Cord, AC Power	GENERAL EXPORT
4 - 62	* 55300470	Strain Relief, AC Cord	All except EUROPE, U.K.
4 - 63	* 55546580	Bracket, PC Board; A	
4 - 64	* 51672920	PC Board, Trap Coil	
4 - 65	* 55546940	Bracket, Trap Coil PC Board	
4 - 67	51682790	PC Board Assy, Dolby B-type Processor	
4 - 68	* 55546480	Plate, R	
4 - 69	51682822	PC Board Assy, Lever Switch	
4 - 70	51320170	Switch, Lever	
4 - 71	51320210	Switch, Lever	
4 - 72	* 51672830	PC Board, TIMER Switch	JAPAN
	* 51672900	PC Board, FM/COPY Switch	All except JAPAN
4 - 73	* 51320220	Switch, Lever	JAPAN
	* 51320190	Switch, Lever	All except JAPAN
4 - 74	* 55546511	Bracket, Lever Switch	
4 - 75	55240440	Spring, Grounding	
4 - 76	* 55547560	Shield Paper, AC	
4 - 77	51683610	PC Board Assy, Fuse	All except JAPAN, GENERAL EXPORT
	* 50411570	Fuse, 4A (2 used)	U.S.A., CANADA, AUSTRALIA
	* 50411440	Fuse, 2A	U.S.A., CANADA, AUSTRALIA
	* 50411460	Fuse, 500mA	U.S.A., CANADA, AUSTRALIA
	* 50411560	Fuse, 4AF (2 used)	EUROPE, U.K.
	* 50411550	Fuse, 2AF	EUROPE, U.K.
	* 50411540	Fuse, 500mAF	EUROPE, U.K.
4 - 78	51683620	PC Board Assy, VU Level Meter	All except JAPAN
4 - 79	* 51310070	Voltage Selector	GENERAL EXPORT
4 - 80	* 55541690	Plate, Selector	GENERAL EXPORT
4 - 81	* 55340841	Clamp, AC Power Cord	EUROPE, U.K.
4 - 82	* 55547540	Bracket, Clamp	EUROPE, U.K.
4 - 83	* 55548120	Plate, shield	All except JAPAN, U.S.A., CANADA

2. PC BOARD SECTION (Diagram)

1. RECORD/PLAYBACK AMPL.

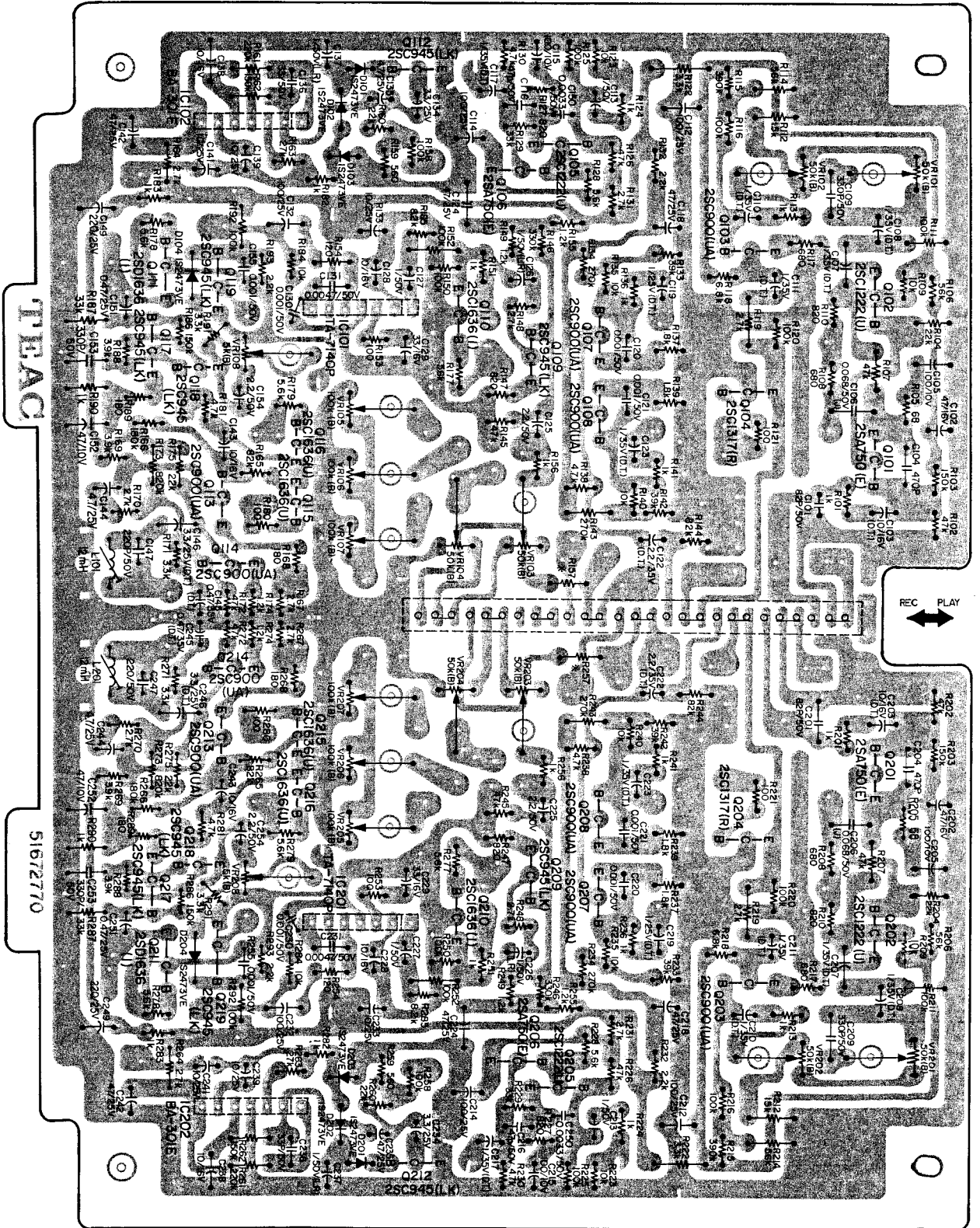

P-198

*	JAPAN	All except JAPAN
RI57/R257	68k	27k

2. CONTROL PC BOARD

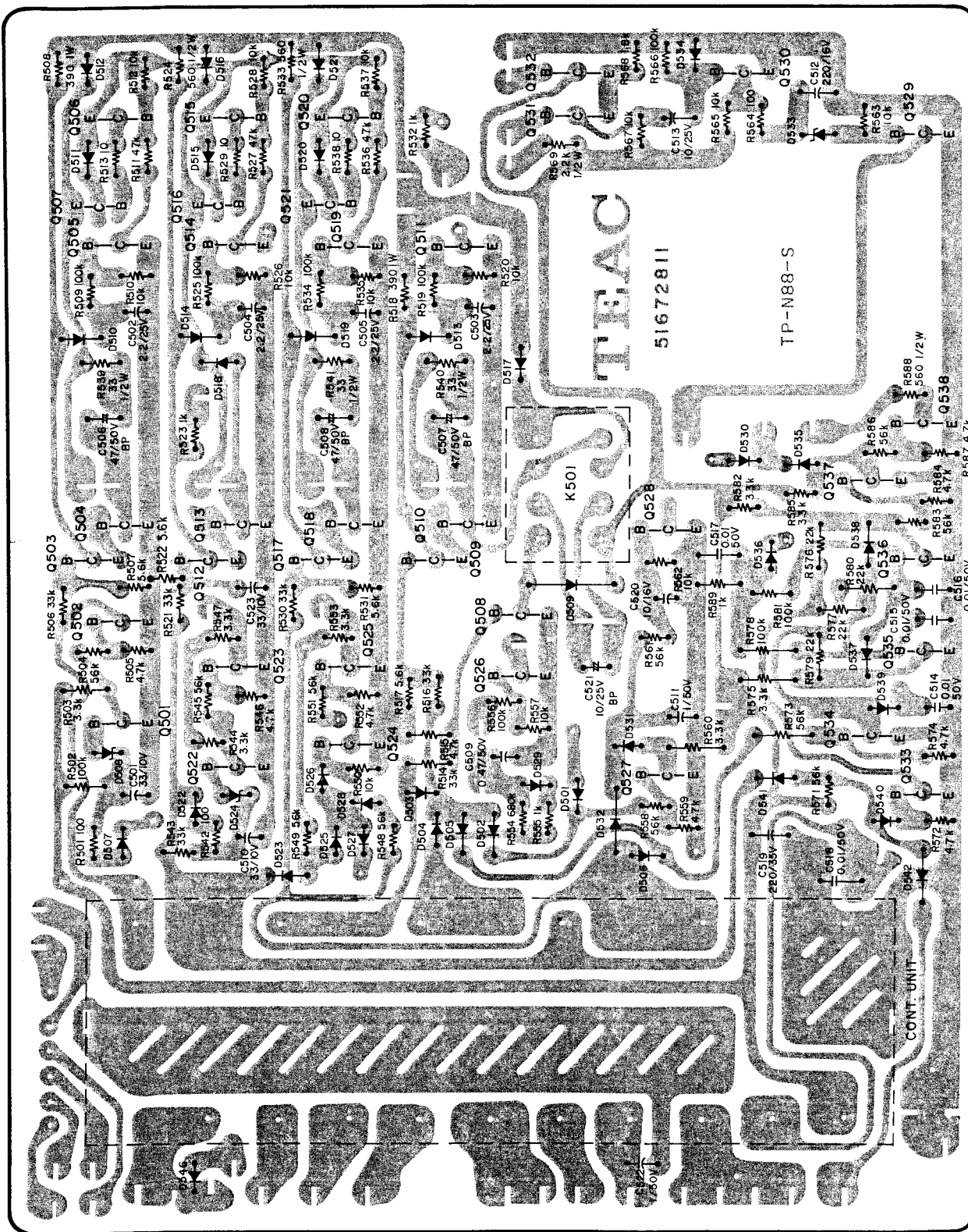

3. DOLBY B TYPE PROCESSOR

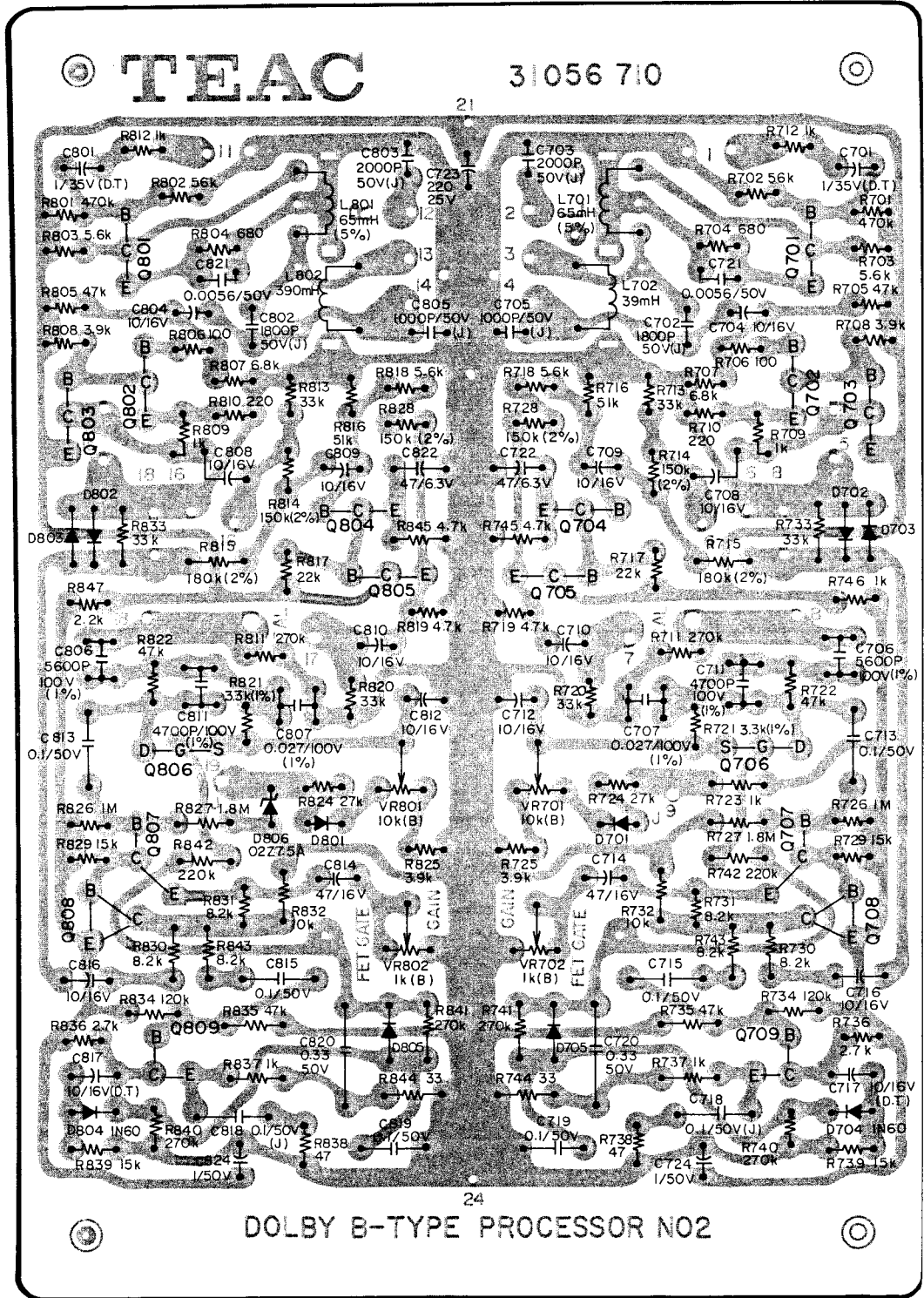

4. POWER SUPPLY

(All except JAPAN)

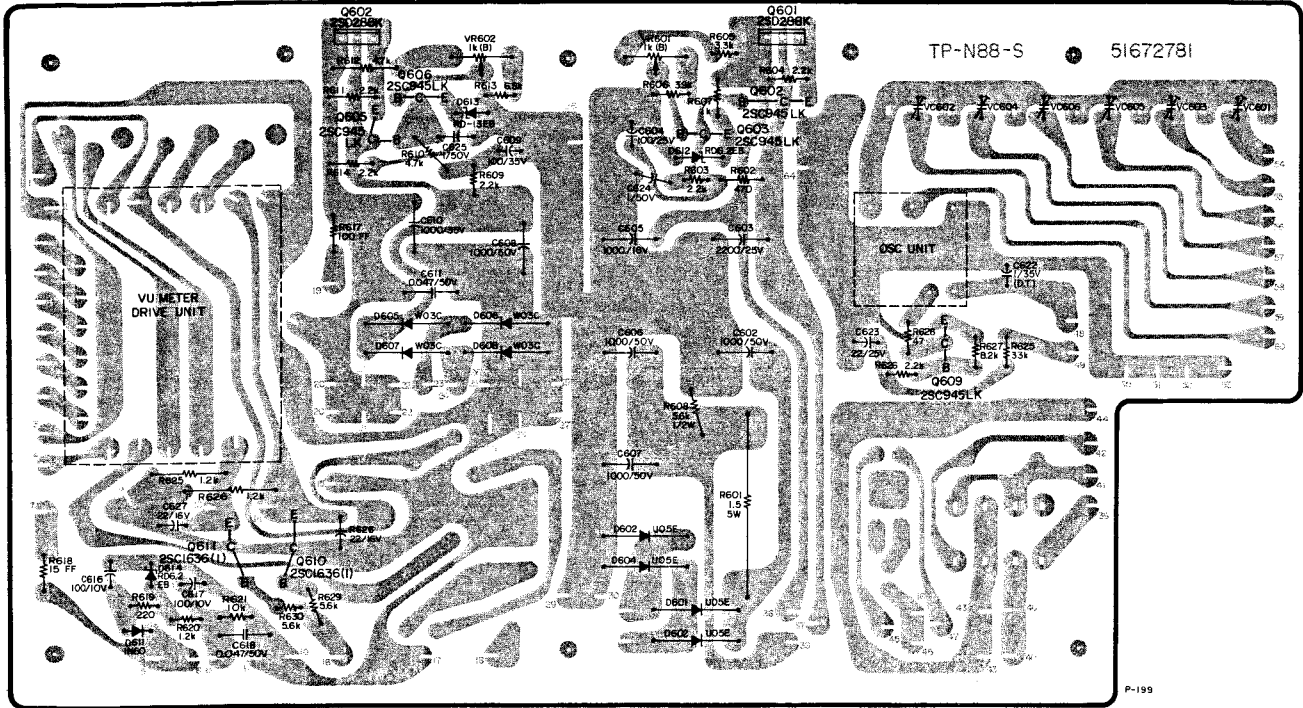

(JAPAN)

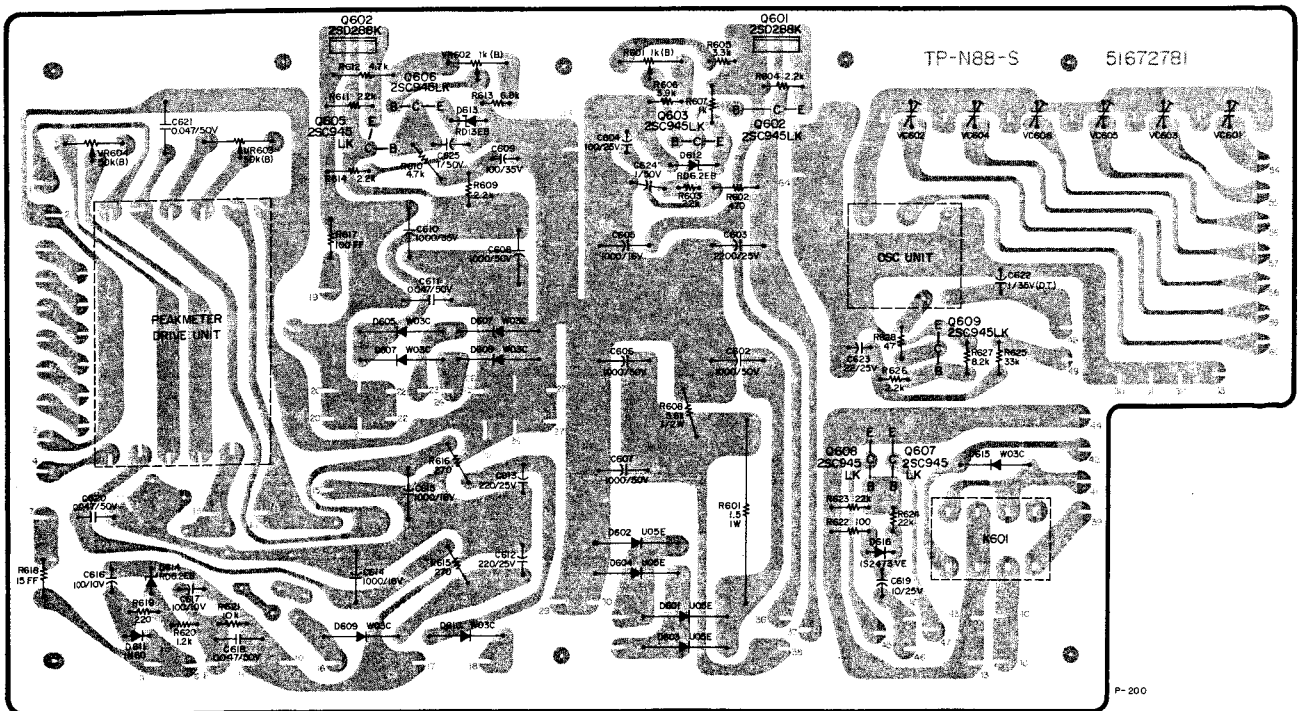

5. INPUT-OUTPUT PC BOARD

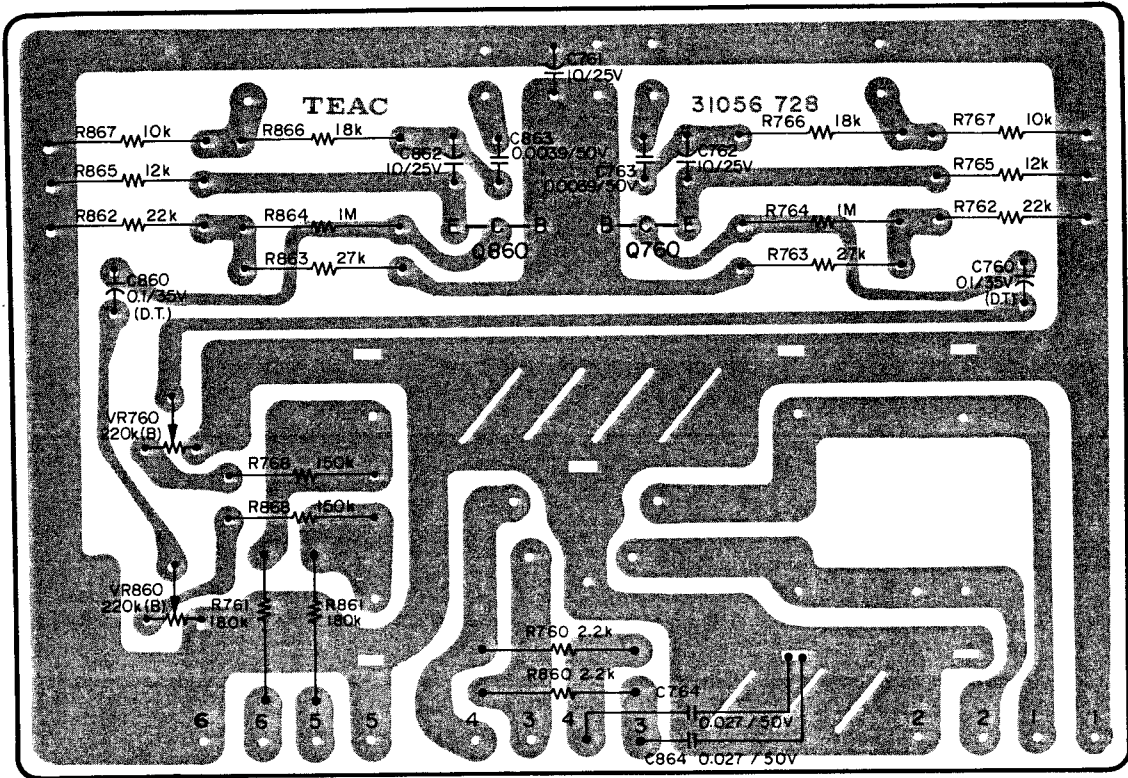

P-204

6. LEVER SWITCH PC BOARD

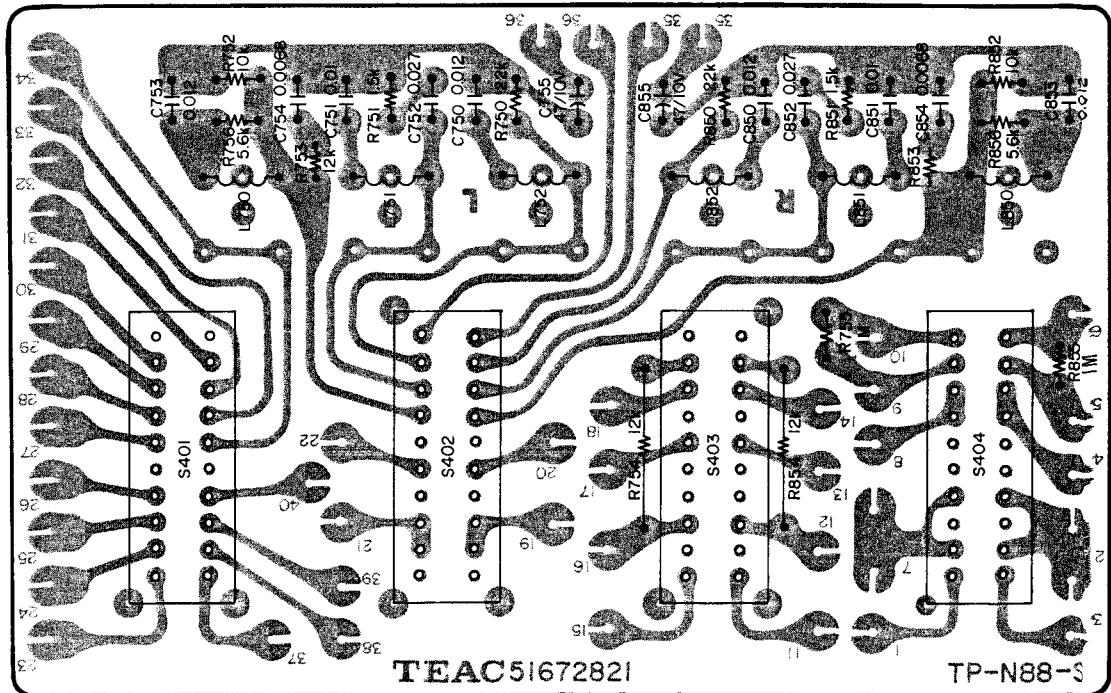

P-203

7. MUTING PC BOARD

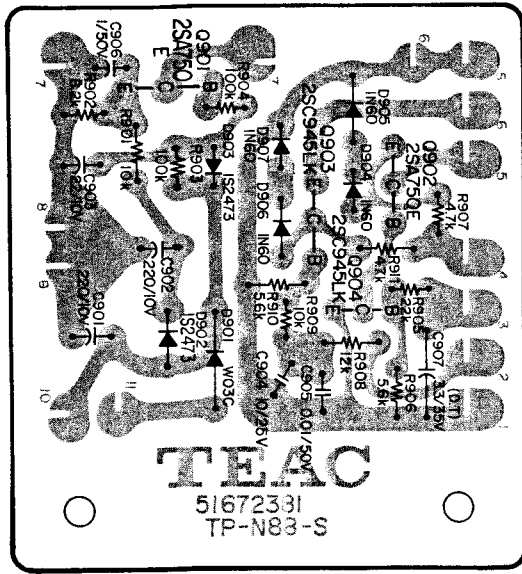

P-205

8. VU LEVEL METER PC BOARD

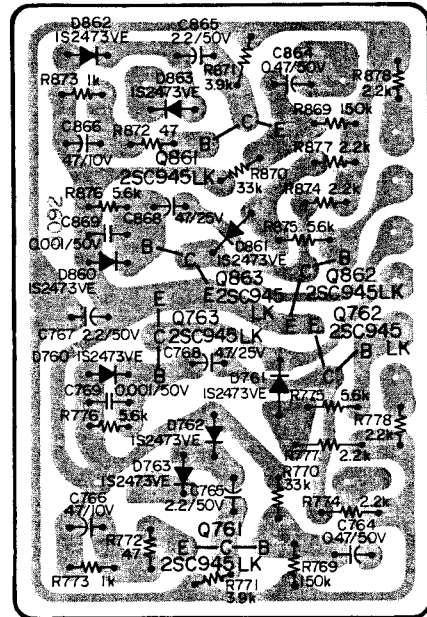

P-206

2. PC BOARD SECTION (Parts List)

1. RECORD/PLAYBACK AMPL.

REF. NO.	PARTS NO.	DESCRIPTION
	51682773	PC Bd. Assy (JAPAN)
	51683650	PC Bd. Assy (All except JAPAN)
	51672772	PC Board
	IC's	
IC101/IC201	50427370	TA - 7140P
IC102/IC202	51470180	BA - 301B
	TRANSISTORS	
Q101/Q201	51450380	2SA750 (E)
Q102/Q202	50425520	2SC1222 (U)
Q103/Q203	51450340	2SC900 (UA)
Q104/Q204	50424670	2SC1317 (R)
Q105/Q205	50425520	2SC1222 (U)
Q106/Q206	51450380	2SA750 (E)
Q107/Q207	51450340	2SC900 (UA)
Q108/Q208	51450340	2SC900 (UA)
Q109/Q209	51450360	2SC945 (LK)
Q110/Q210	50425490	2SC1636 (I)
Q111/Q211	50425490	2SC1636 (I)
Q112/Q212	51450360	2SC945 (LK)
Q113/Q213	51450340	2SC900 (UA)
Q114/Q214	51450340	2SC900 (UA)
Q115/Q215	50425490	2SC1636 (I)
Q116/Q216	50425490	2SC1636 (I)
Q117/Q217	51450360	2SC945 (LK) (All except JAPAN)
Q118/Q218	51450360	2SC945 (LK) (All except JAPAN)
Q119/Q219	51450360	2SC945 (LK) (All except JAPAN)

REF. NO.	PARTS NO.	DESCRIPTION
	DIODES	
D101/D201	50425170	1S2473VE
D102/D202	50425170	1S2473VE
D103/D203	50425170	1S2473VE
D104/D204	50425170	1S2473VE (All except JAPAN)
	CARBON RESISTORS	
All resistors are rated $\pm 5\%$ tolerance and 1/4 watt unless otherwise noted.		
R101/R201	50570820	1k ohm
R102/R202	50571220	47k ohm
R103/R203	50571340	150k ohm
R104/R204	50571140	22k ohm
R105/R205	50570540	68 ohm
R106/R206	50571240	56k ohm
R107/R207	50571220	47k ohm
R108/R208	50570780	680 ohm
R109/R209	50571060	10k ohm
R110/R210	50570800	820 ohm
R111/R211	50571300	100k ohm
R112/R212	50571100	15k ohm
R113/R213	50570820	1k ohm
R114/R214	50571240	56k ohm
R115/R215	50571440	390k ohm
R116/R216	50571300	100k ohm
R117/R217	50570780	680 ohm
R118/R218	50571020	6.8k ohm
R119/R219	50570920	2.7k ohm
R120/R220	50571300	100k ohm

REF. NO.	PARTS NO.	DESCRIPTION
R121/R221	50570580	100 ohm
R122/R222	50570940	3.3k ohm
R123/R223	50571060	10k ohm
R124/R224	50570820	1k ohm
R125/R225	50571300	100k ohm
R126/R226	50571220	47k ohm
R127/R227	50570800	820 ohm
R128/R228	50571000	5.6k ohm
R129/R229	50571180	33k ohm
R130/R230	50570980	4.7k ohm
R131/R231	50570920	2.7k ohm
R132/R232	50570900	2.2k ohm
R133/R233	50571200	39k ohm
R134/R234	50571400	270k ohm
R135/R235	50571060	10k ohm
R136/R236	50570820	1k ohm
R137/R237	50570880	1.8k ohm
R138/R238	50570980	4.7k ohm
R139/R239	50570880	1.8k ohm
R140/R240	50571060	10k ohm
R141/R241	50570820	1k ohm
R142/R242	50571200	39k ohm
R143/R243	50571400	270k ohm
R144/R244	50571280	82k ohm
R145/R245	50571220	47k ohm
R146/R246	50571420	330k ohm
R147/R247	50570800	820 ohm
R148/R248	50570920	2.7k ohm
R149/R249	50570840	1.2k ohm
R150/R250	50571300	100k ohm
R151/R251	50570820	1k ohm
R152/R252	50571300	100k ohm
R153/R253	50570580	100 ohm
R154/R254	50570600	120 ohm
R155/R255	50570840	1.2k ohm
R156/R256	50570820	1k ohm
R157/R257	50571260	68k ohm (JAPAN)
R157/R257	50571160	27k ohm (All except JAPAN)
R158/R258	50571300	100k ohm
R159/R259	50570760	560 ohm
R160/R260	50571140	22k ohm
R161/R261	50571380	220k ohm
R162/R262	50571340	150k ohm
R163/R263	50571160	27k ohm
R164/R264	50570920	2.7k ohm
R165/R265	50571280	82k ohm
R166/R266	50571360	180k ohm
R167/R267	50570920	2.7k ohm
R168/R268	50570640	180 ohm
R169/R269	50570960	3.9k ohm
R170/R270	50570920	2.7k ohm
R171/R271	50570940	3.3k ohm
R172/R272	50571220	47k ohm
R173/R273	50571520	820k ohm
R174/R274	50570840	1.2k ohm
R175/R275	50571140	22k ohm
R177/R277	50571000	5.6k ohm
R178/R278	50571000	5.6k ohm
R179/R279	50571000	5.6k ohm
R180/R280	50570580	100 ohm
R181/R281	50570980	4.7k ohm
R182/R282	50570820	1k ohm
R183/R283	50570820	1k ohm
R184/R284	50571060	10k ohm
R185/R285	50571040	8.2k ohm

REF. NO.	PARTS NO.	DESCRIPTION
R186/R286	50571340	150k ohm (All except JAPAN)
R187/R287	50571180	33k ohm (All except JAPAN)
R188/R288	50570960	3.9k ohm (All except JAPAN)
R189/R289	50570640	180 ohm (All except JAPAN)
R190/R290	50570820	1k ohm (All except JAPAN)
R191/R291	50570940	3.3k ohm (All except JAPAN)
R192/R292	50571300	100k ohm (All except JAPAN)
R193/R293	50570900	2.2k ohm (All except JAPAN)

CAPACITORS

C101/C201	50547580	Dip. Mica	82 pfd	50V
C102/C202	50554010	Elec.	47 mfd	16V
C103/C203	50546561	Dip. Tant.	10 mfd	16V
C104/C204	50547560	Dip. Mica	470 pfd	50V
C105/C205	50544570	Elec.	100 mfd	10V
C106/C206	50549260	Mylar	0.068 mfd	50V 5%
C107/C207	50546701	Dip. Tant.	1 mfd	35V
C108/C208	50546701	Dip. Tant.	1 mfd	35V
C109/C209	50547460	Dip. Mica	330 pfd	50V
C110/C210	50546701	Dip. Tant.	1 mfd	35V
C111/C211	50546701	Dip. Tant.	1 mfd	35V
C112/C212	50554170	Elec.	100 mfd	25V
C113/C213	51700860	Elec.	1 mfd	50V (LR)
C114/C214	50554170	Elec.	100 mfd	25V
C115/C215	50554570	Elec.	100 mfd	10V
C116/C216	50547420	Dip. Mica	47 pfd	50V
C117/C217	50546700	Dip. Tant.	1 mfd	35V
C118/C218	50554490	Elec.	47 mfd	25V
C119/C219	50546701	Dip. Tant.	1 mfd	35V
C120/C220	50548320	Mylar	0.001 mfd	50V 10%
C121/C221	50548320	Mylar	0.001 mfd	50V 10%
C122/C222	50546720	Dip. Tant.	2.2 mfd	35V
C123/C223	50546701	Dip. Tant.	1 mfd	35V
C124/C224	50554490	Elec.	47 mfd	25V
C125/C225	50554980	Elec.	2.2 mfd	50V
C126/C226	51700860	Elec.	1 mfd	50V (LR)
C127/C227	50554540	Elec.	1 mfd	50V
C128/C228	50554050	Elec.	10 mid	16V
C129/C229	50554260	Elec.	33 mfd	16V
C130/C230	50548780	Mylar	0.001 mfd	50V 5%
C131/C231	50548910	Mylar	0.0047 mfd	50V 5%
C132/C232	50554170	Elec.	100 mfd	25V
C133/C233	50554040	Elec.	10 mid	25V
C134/C234	50554220	Elec.	3.3 mfd	25V
C135/C235	50554530	Elec.	4.7 mfd	25V
C136/C236	50547590	Dip. Mica	33 pfd	50V
C137/C237	51700860	Elec.	1 mfd	50V (LR)
C138/C238	50554050	Elec.	10 mid	16V
C139/C239	50554040	Elec.	10 mid	25V
C141/C241	50554040	Elec.	10 mid	25V
C142/C242	50554490	Elec.	47 mfd	25V
C143/C243	50554050	Elec.	10 mid	16V
C144/C244	50554530	Elec.	4.7 mfd	25V
C145/C245	50546681	Dip. Tant.	0.47 nfd	35V
C146/C246	50546600	Dip. Tant.	3.3 nfd	25V
C147/C247	50547450	Dip. Mica	220 pfd	50V
C149/C249	50554181	Elec.	220 nfd	25V
C150/C250	50548810	Mylar	0.003 mfd	50V 5%
C151/C251	50554930	Elec.	0.47 nfd	50V (All except JAPAN)
C152/C252	50554010	Elec.	47 mid	10V (All except JAPAN)
C153/C253	50547460	Dip. Mica	330 pfd	50V (All except JAPAN)

REF. NO.	PARTS NO.	DESCRIPTION
C154/C254	50554940	Elec. 2.2 mfd 50V (All except JAPAN)
C155/C255	50542030	Ceramic 0.001 mfd 50V (All except JAPAN)

VARIABLE RESISTORS

VR101/VR201	51500570	Semi-fixed, 50k ohm B
VR102/VR202	51500570	Semi-fixed, 50k ohm B
VR103/VR203	51500570	Semi-fixed, 50k ohm B
VR104/VR204	51500570	Semi-fixed, 50k ohm B
VR105/VR205	51501060	Semi-fixed, 100k ohm B
VR106/VR206	51501060	Semi-fixed, 100k ohm B
VR107/VR207	51501060	Semi-fixed, 100k ohm B
VR108/VR208	51500970	Semi-fixed, 5k ohm B (All except JAPAN)

COILS

L101/L201	50566550	Trap, 12mH
-----------	----------	------------

MISCELLANEOUS

S301	50444620	Switch, Slide 9PDT
------	----------	--------------------

2. CONTROL PC BOARD

REF. NO.	PARTS NO.	DESCRIPTION
	51682811	PC Bd. Assy
	51672811	PC Board
TRANSISTORS		
Q501, Q502	51450360	2SC945 (LK)
Q503, Q509	50426250	2SC1318 (S)
Q504, Q510	50425290	2SD389 (P)
Q505	51450360	2SC945 (LK)
Q506, Q515	50425530	2SA733 (P)
Q507, Q516	50425270	2SD288 (K)
Q508, Q511	51450360	2SC945 (LK)
Q512, Q517	50426250	2SC1318 (S)
Q513, Q518	50425290	2SD387 (P)
Q514	51450360	2SC945 (LK)
Q519, Q522	51450360	2SC945 (LK)
Q520	50425530	2SA733 (P)
Q521	50425270	2SD288 (K)
Q523~Q538	51450360	2SC945 (K)
DIODES		
D501~D507	50425170	Silicon 1S2473VE
D508, D524	50425540	Zener RD6.2EB 3%
D509~D521	51430890	Silicon W03C
D522, D523	50425170	Silicon 1S2473VE
D525~D532	50425170	Silicon 1S2473VE
D533	50422640	Zener 02Z-7.5A
D534~D542	50425170	Silicon 1S2473VE
D546	50425170	Silicon 1S2473VE

REF. NO.	PARTS NO.	DESCRIPTION
----------	-----------	-------------

RELAY

K501	50611000	MX2P-0 24V
------	----------	------------

CARBON RESISTORS

All resistors are rated $\pm 5\%$ tolerance, 1/4 watt and of carbon type unless otherwise noted.

R501	50570580	100 ohm
R502	50571300	100k ohm
R503	50570940	3.3k ohm
R504	50571240	56k ohm
R505	50570980	4.7k ohm
R506	50571180	33k ohm
R507	50571000	5.6k ohm
R508	50527370	Metal Oxied Film 390 ohm 1W 10%
R509	50571300	100k ohm
R510	50571060	10k ohm
R511	50571220	47k ohm
R512	50571060	10k ohm
R513	50570340	10 ohm
R514	50571180	33k ohm
R515	50570980	4.7k ohm
R516	50571180	33k ohm
R517	50571000	5.6k ohm
R518	50527370	Metal Oxied Film 390 ohm 1W 10%
R519	50571300	100k ohm
R520	50571060	10k ohm
R521	50571180	33k ohm
R522	50571000	5.6k ohm
R523	50570820	1k ohm
R524	51802760	560 ohm 1/2W
R525	50571300	100k ohm
R526	50571060	10k ohm
R527	50571220	47k ohm
R528	50571060	10k ohm
R529	50570340	10 ohm
R530	50571180	33k ohm
R531	50571000	5.6k ohm
R532	50570820	1k ohm
R533	51802760	560 ohm 1/2W
R534	50571300	100k ohm
R535	50571060	10k ohm
R536	50571220	47k ohm
R537	50571060	10k ohm
R538	50570340	10 ohm
R539~R541	50529300	Fusible Type 33 ohm 1/2W
R542	50570580	100 ohm
R543	50571180	33k ohm
R544	50570940	3.3k ohm
R545	50571240	56k ohm
R546	50570980	4.7k ohm
R547	50570940	3.3k ohm
R548, R549	50571240	56k ohm
R550	50571060	10k ohm
R551	50571240	56k ohm
R552	50570980	4.7k ohm
R553	50570940	3.3k ohm
R554	50571500	680k ohm
R555	50570820	1k ohm
R556	50571300	100k ohm
R557	50571060	10k ohm
R558	50571240	56k ohm
R559	50570980	4.7k ohm
R560	50570940	3.3k ohm

REF. NO.	PARTS NO.	DESCRIPTION
R561	50571240	56k ohm
R562, R563	50571060	10k ohm
R564	50570580	100 ohm
R565	50571060	10k ohm
R566	50571300	100k ohm
R567	50571060	10k ohm
R568	50570880	1.8k ohm
R569	51802900	2.2k ohm 1/2W
R571	50571240	56k ohm
R572	50570980	4.7k ohm
R573	50571240	56k ohm
R574	50570980	4.7k ohm
R575	50570940	3.3k ohm
R576, R577	50571140	22k ohm
R578	50571300	100k ohm
R579, R580	50571140	22k ohm
R581	50571300	100k ohm
R582	50570940	3.3k ohm
R583	50571240	56k ohm
R584	50570980	4.7k ohm
R585	50570940	3.3k ohm
R586	50571240	56k ohm
R587	50570980	4.7k ohm
R588	51802760	560 ohm 1/2W
R589	50570820	1k ohm

CAPACITORS

C501, C510	50546511	Dip. Tant.	33 mfd	10V
C502~C505	50549670	Elec.	2.2 mfd	25V (KU)
C506~C508	50559490	Elec.	47 mfd	50V
			(Bi-Polar)	
C509	50554970	Elec.	0.47 mfd	50V
C511	50554540	Elec.	1 mfd	50V
C512	50554390	Elec.	220 mfd	16V
C513	51700820	Elec.	10 mfd	25V
C514~C518	50542040	Ceramic	0.01 mfd	50V
C519	50554380	Elec.	220 mfd	35V
C520	50554050	Elec.	10 mfd	16V
C521	50559350	Elec.	10 mfd	25V
			(Bi-Polar)	
C522	50554540	Elec.	1 mfd	50V
C523	50546511	Dip. Tant.	33 mfd	10V

MISCELLANEOUS

51220630 Pin Connector, Plug; 6P

3. DOLBY B TYPE PROCESSOR

REF. NO.	PARTS NO.	DESCRIPTION
	51682790	PC Bd. Assy
	51672790	PC Board
TRANSISTORS		
Q701/Q801	50424610	2SC1327 (T) or
	50424340	2SC1000 (BL)
Q702/Q802	50423590	2SC644 (S) or
	50424100	2SC1000 (GR)

REF. NO.	PARTS NO.	DESCRIPTION
Q703/Q803	50424210	2SA666 I S or
	50424320	2SA493 (GR) 21
Q704/Q804	50424940	2SC900 (E)
Q705/Q805	50423590	2SC644 (S) or
	50424100	2SC1000 (GR)
Q706/Q806	57240981	FET 2SK30 (DA) or
	57240991	FET 2SK30 (DB)
Q707/Q807	50424610	2SC1327 (T)
	50424100	2SC1000 (GR)
Q708/Q808	50424210	2SA666 I S
	50424320	2SA493 (GR) 21
Q709/Q809	50424940	2SC900 (E)

DIODES

D701/D801	50422330	Silicon	M8513A - O
D702/D802	50422330	Silicon	M8513A - O
D703/D803	50422330	Silicon	M8513A - O
D704/D804	50422170	Germanium	1N60
D705/D805	50422330	Silicon	M8513A - O
D806	50422640	Zener	02Z - 7.5A

CARBON RESISTORS

All resistors are rated $\pm 5\%$ tolerance and 1/4 watt unless otherwise noted.

R701/R801	50571460	470k ohm
R702/R802	50571240	56k ohm
R703/R803	50571000	5.6k ohm
R704/R804	50570780	680 ohm
R705/R805	50571220	47k ohm
R706/R806	50570580	100 ohm
R707/R807	50571020	6.8k ohm
R708/R808	50570960	3.9k ohm
R709/R809	50570820	1k ohm
R710/R810	50570660	220 ohm
R711/R811	50571400	270k ohm
R712/R812	50570820	1k ohm
R713/R813	50571180	33k ohm
R714/R814	50529510	150k ohm 2%
R715/R815	50529520	180k ohm 2%
R716/R816	50571230	51k ohm
R717/R817	50571140	22k ohm
R718/R818	50571000	5.6k ohm
R719/R819	50570980	4.7k ohm
R720/R820	50571180	33k ohm
R721/R821	50529630	3.3k ohm 1%
R722/R822	50571220	47k ohm
R723	50570820	1k ohm
R724/R824	50571160	27k ohm
R725/R825	50570960	3.9k ohm
R726/R826	50571540	1 Mohm
R727/R827	50571600	1.8 Mohm
R728/R828	50529510	150k ohm 2%
R729/R829	50571100	15k ohm
R730/R830	50571040	8.2k ohm
R731/R831	50571040	8.2k ohm
R732/R832	50571060	10k ohm
R733/R833	50571180	33k ohm
R734/R834	50571320	120k ohm
R735/R835	50571220	47k ohm
R736/R836	50570920	2.7k ohm
R737/R837	50570820	1k ohm
R738/R838	50570520	47 ohm
R739/R839	50571100	15k ohm
R740/R840	50571400	270k ohm

REF. NO.	PARTS NO.	DESCRIPTION
R741/R841	50571400	270k ohm
R742/R842	50571380	220k ohm
R743/R843	50571040	8.2k ohm
R744/R844	50570460	33 ohm
R745/R845	50570980	4.7k ohm
R746	50570820	1k ohm
R747	50570900	2.2k ohm

CAPACITORS

C701/C801	50546701	Dip. Tant.	1 mfd	35V
C702/C802	50539900	Polyst.	1800 pfd	50V 5%
C703/C803	50544070	Polyst.	2000 pfd	50V 5%
C704/C804	50554050	Elec.	10 mfd	16V
C705/C805	50543980	Polyst.	1000 pfd	50V 5%
C706/C806	51700130	Meta. Polyst.	0.0056 mfd	100V 1%
C707/C807	51700140	Meta. Polyst.	0.027 mfd	100V 1%
C708/C808	50554050	Elec.	10 mfd	16V
C709/C809	50554050	Elec.	10 mfd	16V
C710/C810	50554050	Elec.	10 mfd	16V
C711/C811	51700120	Meta Polyst.	0.0047 mfd	100V 1%
C712/C812	50554050	Elec.	10 mfd	16V
C713/C813	50548040	Mylar	0.1 mfd	50V 10%
C714/C814	50554010	Elec.	47 mfd	16V
C715/C815	50548040	Mylar	0.1 mfd	50V 10%
C716/C816	50554050	Elec.	10 mfd	16V
C717/C817	50546561	Dip. Tant.	10 mfd	16V
C718/C818	50549280	Mylar	0.1 mfd	50V 5%
C719/C819	50548040	Mylar	0.1 mfd	50V 10%
C720/C820	50548830	Metalized Mylar	0.33 mfd	50V 10%
C721/C821	50548920	Mylar	0.0056 mfd	50V 5%
C722/C822	50554030	Elec.	47 mfd	6.3V
C723	50554180	Elec.	220 mfd	25V
C724/C824	50554540	Elec.	1 mfd	50V

VARIABLE RESISTORS

VR701/VR801	50533480	Semi-fixed	10k ohm B
VR702/VR802	50533500	Semi-fixed	1k ohm B

COILS

L701/L801	57244060	Choke, 65mH	5% (Fixed)
L702/L802	57244050	Choke, 39mH	(Adjustable)

MISCELLANEOUS

57240420	Pin, F3 Type	(5 used)
----------	--------------	----------

4. POWER SUPPLY

REF. NO.	PARTS NO.	DESCRIPTION
	51682781	PC Bd. Assy (JAPAN)
	51683600	PC Bd. Assy (All except JAPAN)
	51672781	PC Board

REF. NO.	PARTS NO.	DESCRIPTION
----------	-----------	-------------

TRANSISTORS

Q601, Q604	50425270	2SD288 (K)
Q602, Q603	51450360	2SC945 (LK)
Q605, Q606	51450360	2SC945 (LK)
Q607~Q609	51450360	2SC945 (LK) (JAPAN)
Q610, Q611	50425490	2SC1636 (I) (All except JAPAN)

DIODES

D601~D604	51430183	Silicon	U05E
D605~D608	51430890	Silicon	W03C
D609~D610	51430890	Silicon	W03C (JAPAN)
D611	50422130	Silicon	1N60
D612, D614	50425540	Zener	RD6.2EB 3%
D613	50430860	Zener	RD13E 3%
D615	51430890	Silicon	W03C (JAPAN)
D616	50425170	Silicon	1S2473VE (JAPAN)

RELAY

K601	50611000	MX2P - 0	24V	(JAPAN)
------	----------	----------	-----	---------

CARBON RESISTORS

All resistors are rated $\pm 5\%$ tolerance, 1/4 watt and of carbon type unless otherwise noted.

R601	50520570	Cement	1.5 ohm	5W
R602	50570740	Fusible Type	470 ohm	
R603, R604	50570900		2.2k ohm	
R605	50570940		3.3k ohm	
R606	50570960		3.9k ohm	
R607	50570820		1k ohm	
R608	51803000		5.6k ohm	1/2W
R609	50570900		2.2k ohm	
R610	50570980		4.7k ohm	
R611	50570900		2.2k ohm	
R612	50570980		4.7k ohm	
R613	50571020		6.8k ohm	
R614	50570900		2.2k ohm	
R615, R616	50570680		270 ohm	(JAPAN)
R617	50529310	Fusible Type	100 ohm	
R618	50529320	Fusible Type	15 ohm	
R619	50570660		220 ohm	
R620	50570840		1.2k ohm	
R621	50571060		10k ohm	(JAPAN)
R622	50570580		100 ohm	(JAPAN)
R623, R624	50571140		22k ohm	(JAPAN)
R625	50571180		33k ohm	(JAPAN)
R631	50570840		1.2k ohm	(All except JAPAN)
R626	50570900		2.2k ohm	(JAPAN)
R632	50570840		1.2k ohm	(All except JAPAN)
R627	50571040		8.2k ohm	
R628	50570500		47 ohm	
R629, R630	50571000		5.6k ohm	(All except JAPAN)

CAPACITORS

C602	50555850	Elec.	1000 mfd	50V
C603	50557140	Elec.	2200 mfd	25V
C604	50554170	Elec.	100 mfd	25V
C605	50554890	Elec.	1000 mfd	16V
C606~C608	50555850	Elec.	1000 mfd	50V
C609	50554630	Elec.	100 mfd	35V
C610	51700110	Elec.	1000 mfd	35V

REF. NO.	PARTS NO.	DESCRIPTION
C611	50542300	Ceramic 0.047 mfd 50V
C612, C613	50554180	Elec. 220 mfd 25V (JAPAN)
C614, C615	50554890	Elec. 1000 mfd 16V (JAPAN)
C616, C617	50554570	Elec. 100 mfd 10V
C618	50542300	Ceramic 0.047 mfd 50V
C619	50554040	Elec. 10 mfd 25V (JAPAN)
C620, C621	50542300	Ceramic 0.047 mfd 50V (JAPAN)
C622	50546701	Dip. Tant. 1 mfd 35V
C623	50554950	Elec. 22 mfd 25V
C624, C625	50554540	Elec. 1 mfd 50V
C626, C627	50555370	Elec. 22 mfd 16V (All except JAPAN)

VARIABLE RESISTORS

VR601, VR602	50534200	Semi-fixed 1k ohm B
VR603, VR604	50534380	Semi-fixed 50k ohm B (JAPAN)

TRIMMER CAPACITORS

VC601~VC606	51700180	220 pfd Max.
-------------	----------	--------------

MISCELLANEOUS

50400860	Oscillator Unit
50400850	P.P.M. Drive Ampl. Unit (JAPAN)
50332910	Plate, Insulator
50339250	Washer, Insulator

5. INPUT-OUTPUT PC BOARD

REF. NO.	PARTS NO.	DESCRIPTION
	51682800	PC Bd. Assy (JAPAN)
	51682890	PC Bd. Assy (All except JAPAN)
	51672800	PC Board
TRANSISTORS		
Q760/Q860	57240981	FET 2SK30 (DA) or
	57240991	FET 2SK30 (DB) (All except JAPAN)
CARBON RESISTORS		
All resistors are rated $\pm 5\%$ tolerance and 1/4 watt.		
R760/R860	50572900	2.2k ohm
R761/R861	50573360	180k ohm
R762/R862	50573140	22k ohm (All except JAPAN)
R763/R863	50573160	27k ohm (All except JAPAN)
R764/R864	50573540	1M ohm (All except JAPAN)
R765/R865	50573080	12k ohm (All except JAPAN)
R766/R866	50573120	18k ohm (All except JAPAN)
R767/R867	50573060	10k ohm (All except JAPAN)
R768/R868	50573340	150k ohm (All except JAPAN)

REF. NO.	PARTS NO.	DESCRIPTION
CAPACITORS		
C760/C860	50554540	Dip. Tant. 0.1 mfd 35V (All except JAPAN)
C761	50554040	Dip. Tant. 10 mfd 25V (All except JAPAN)
C762/C862	50554040	Dip. Tant. 10 mfd 25V (All except JAPAN)
C763/C863	50548900	Mylar 0.0039 mfd 50V 5% (All except JAPAN)
C764/C864	50548330	Mylar 0.027 mfd 50V 10%
VARIABLE RESISTORS		
VR760/VR860	50534420	Semi-fixed 220k ohm B (All except JAPAN)

6. LEVER SWITCH PC BOARD

REF. NO.	PARTS NO.	DESCRIPTION
	51682820	PC Bd. Assy
	51672820	PC Board
CARBON RESISTORS		
All resistor are rated $\pm 5\%$ tolerance and 1/4 watt.		
R750/R850	50571140	22k ohm
R751/R851	50570860	1.5k ohm
R752/R852	50571060	10k ohm
R753/R853	50571080	12k ohm
R754/R854	50573080	12k ohm
R755/R855	50571540	1 Mohm
R756/R856	50571000	5.6k ohm
CAPACITORS		
C750/C850	50548950	Mylar 0.012 mfd 50V 5%
C751/C851	50548770	Mylar 0.01 mfd 50V 5%
C752/C852	50548990	Mylar 0.027 mfd 50V 5%
C753/C853	50548950	Mylar 0.012 mfd 50V 5%
C754/C854	50548930	Mylar 0.0068 mfd 50V 5%
C755/C855	50555540	Elec. 47 mfd 10V
COILS		
L750/L850	50562630	Record EQ, 10mH
L751/L851	50562630	Record EQ, 10mH
L752/L852	50562640	Record EQ, 12mH
MISCELLANEOUS		
S401/S402	51320170	Switch, Lever; 4P3T
S403	51320210	Switch, Lever; 4PDT
S404	51320170	Switch, Lever; 4P3T

7. MUTING PC BOARD

REF. NO.	PARTS NO.	DESCRIPTION
	51682881	PC Bd. Assy
	51672881	PC Board
TRANSISTORS		
Q901, Q902	51450380	2SA750(E)
Q903, Q904	51450360	2SC945(LK)
DIODES		
D901	51430890	Silicon W03C
D902, D903	50425170	Silicon 1S2473VE
D904~D907	50422130	Germanium 1N60
CARBON RESISTORS		
All resistors are rated $\pm 5\%$ tolerans and 1/4 watt.		
R901	50571060	10k ohm
R902	50571040	8.2k ohm
R903, R904	50571300	100k ohm
R905	50571140	22k ohm
R906	50571000	5.6k ohm
R907	50570980	4.7k ohm
R908	50571080	12k ohm
R909	50571060	10k ohm
R910	50571000	5.6k ohm
R911	50570980	4.7k ohm
CAPACITORS		
C901, C902	50554910	Elec. 220 mfd 10V
C903	50554720	Elec. 22 mfd 10V
C904	50546631	Dip. Tant. 10 mfd 25V
C905	50542040	Ceramic 0.01 mfd 50V
C906	50554540	Elec. 1 mfd 50V
C907	50546730	Dip. Tant. 3.3 mfd 35V

8. VU LEVEL METER PC BOARD (All except JAPAN)

REF. NO.	PARTS NO.	DESCRIPTION
	51683620	PC Bd. Assy
	51673620	PC Board
TRANSISTORS		
Q761/Q861	51450360	2SC945(LK)
Q762/Q862	51450360	2SC945(LK)
Q763/Q863	51450360	2SC945(LK)
SILICON DIODES		
D760/D860	50425170	1S2473VE
D761/D861	50425170	1S2473VE
D762/D862	50425170	1S2473VE
D763/D863	50425170	1S2473VE
CARBON RESISTORS		
All resistors are rated $\pm 5\%$ tolerance and 1/4 watt.		
R769/R869	50571340	150k ohm
R770/R870	50571180	33k ohm
R771/R871	50570960	3.9k ohm
R772/R872	50570500	47 ohm
R773/R873	50570820	1k ohm
R774/R874	50570900	2.2k ohm
R775/R875	50571000	5.6k ohm
R776/R876	50571000	5.6k ohm
R777/R877	50570820	2.2k ohm
R778/R878	50570820	2.2k ohm
CAPACITORS		
C764/C864	50554930	Elec. 0.47 mfd 50V
C765/C865	50554940	Elec. 2.2 mfd 50V
C766/C866	50554010	Elec. 47 mfd 10V
C767	50554940	Elec. 2.2 mfd 50V
C768/C868	50554080	Elec. 4.7 mfd 25V
C769/C869	50548770	Mylar 0.001 mfd 50V 10%

INCLUDED ACCESSORIES

REF. NO.	PARTS NO.	DESCRIPTION	REMARKS
	51280010	Cords, Input-Output Connection, 2 used	
	57100300	Cleaning Stick (TZ-275)	
	50291350	Silicone Cloth	
	51013690	Information Supplement, Cassette	JAPAN
	51013450	Information Supplement, Cassette	U.S.A., CANADA
	51014130	Information Supplement, Cassette	GENERAL EXPORT, EUROPE, U.K., AUSTRALIA
	51013680	A-650 Owner's Manual	JAPAN
	51014110	A-650 Owner's Manual	U.S.A., CANADA
	51014120	A-650 Owner's Manual	GENERAL EXPORT, EUROPE, U.K., AUSTRALIA

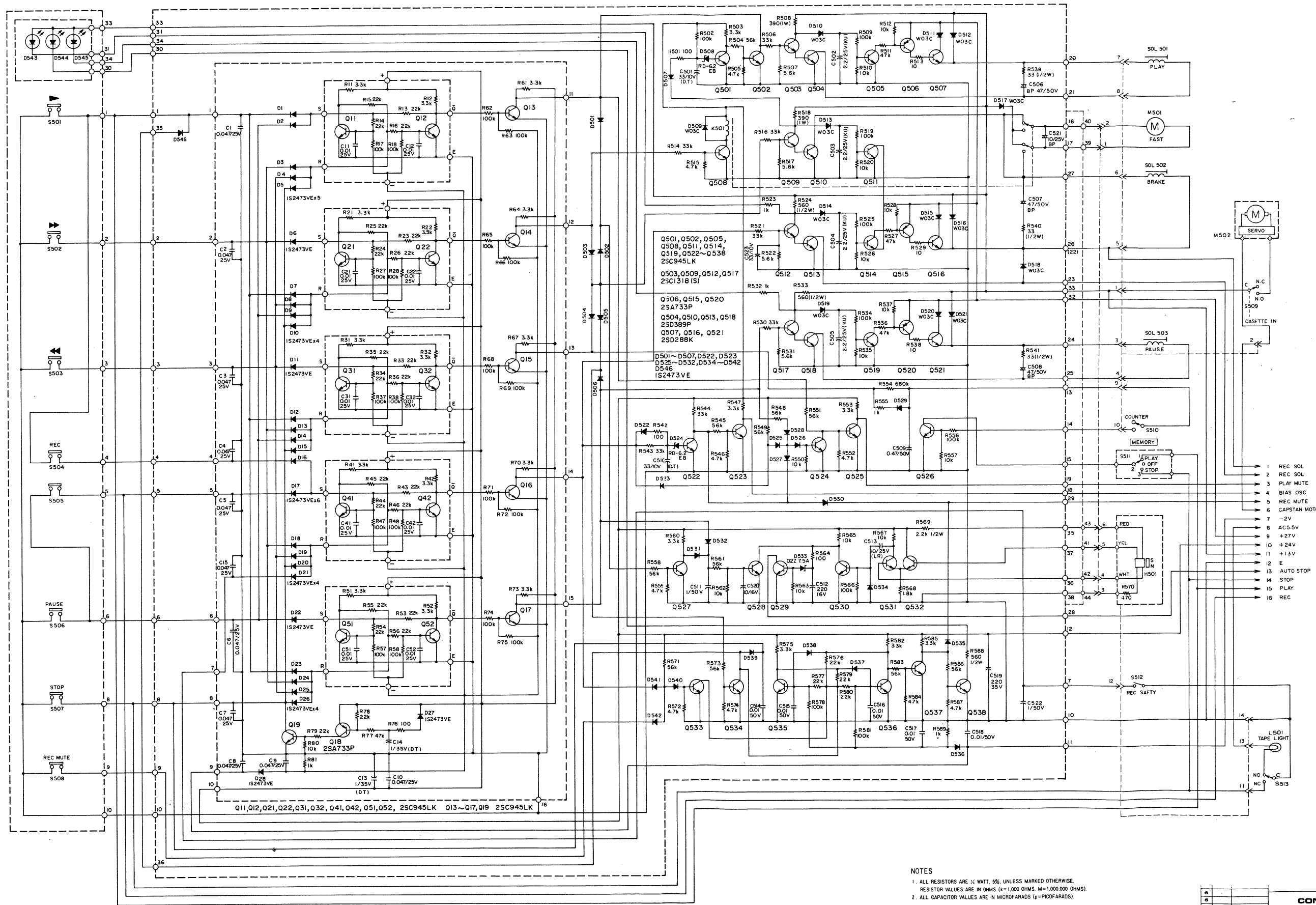

NOTES
 1. ALL RESISTORS ARE 1/2 WATT, 5%, UNLESS MARKED OTHERWISE.
 RESISTOR VALUES ARE IN OHMS (k=1,000 OHMS, M=1,000,000 OHMS).
 2. ALL CAPACITOR VALUES ARE IN MICROFARADS (p=PICOFARADS).

REV	DATE	CHANGE NO.	DESCRIPTION
1	12-76		
2	04-76		
3	09-76		

CONTROL
 MODEL NO. **A-650** SHEET NO. **1**
 TEAC CORPORATION

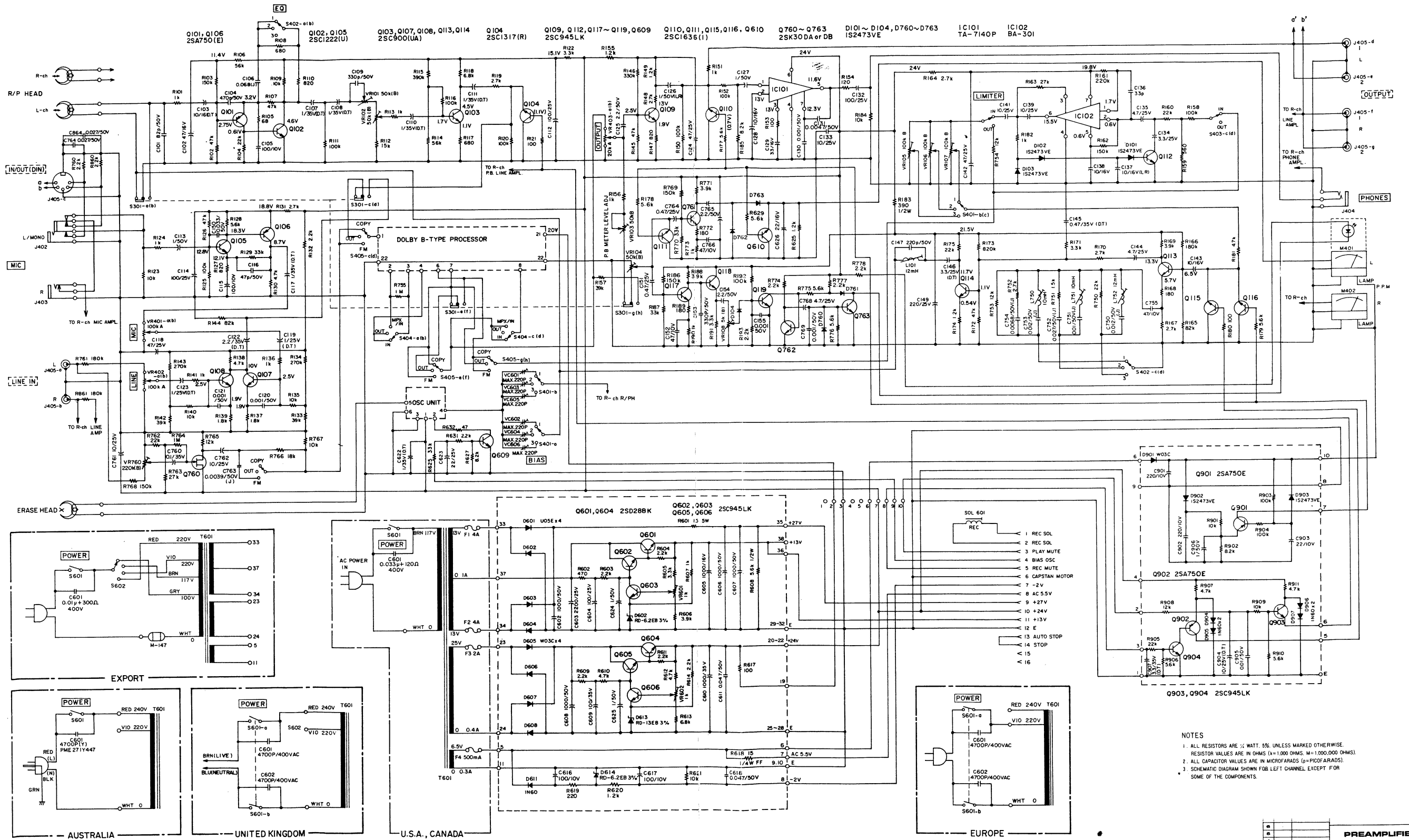

NOTES
 1. ALL RESISTORS ARE 1/2 WATT, 5% UNLESS MARKED OTHERWISE.
 RESISTOR VALUES ARE IN OHMS (K=1,000 OHMS, M=1,000,000 OHMS).
 2. ALL CAPACITOR VALUES ARE IN MICROFARADS (µ=PICOFARADS).
 3. SCHEMATIC DIAGRAM SHOWN FOR LEFT CHANNEL EXCEPT FOR SOME OF THE COMPONENTS.

1	09-76	CD-070	
2	04-76		

REVISION DATE CHANGE NO.

PREAMPLIFIER
 MODEL NO. **A-650** SHEET NO. **1**
TEAC CORPORATION

ASSEMBLING HARDWARE CODING LIST

All screws conform to ISO standards, and have crossrecessed heads, unless otherwise noted. ISO screws have the head inscribed with a point as in the figure to the right.

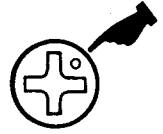

FOR EXAMPLE:

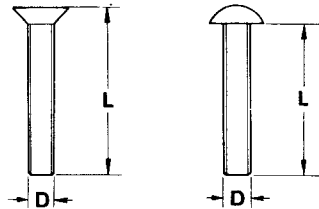
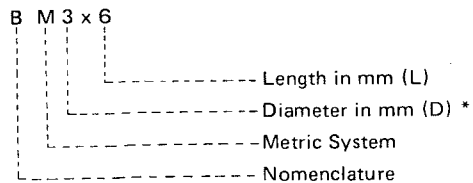

* Inner dia. for washers and nuts

	Code	Name	Type		Code	Name	Type
MACHINE SCREW	R	Round Head Screw		TAPPING SCREW	BTA	Binding Head Tapping Screw(A Type)	
	P	Pan Head Screw			BTB	Binding Head Tapping Screw(B Type)	
	T	Stove Head Screw (Truss)			RTA	Round Head Tapping Screw(A Type)	
	B	Binding Head Screw			RTB	Round Head Tapping Screw(B Type)	
	F	Flat Countersunk Head Screw		SETSCREW	SF	Hex Socket Setscrew(Flat Point)	
	O	Oval Countersunk Head Screw			SC	Hex Socket Setscrew(Cup Point)	
WOOD SCREW	RW	Round Head Wood Screw			SS	Slotted Socket Setscrew(Flat Point)	
	FW	Flat Countersunk Wood Screw		WASHER	E	E-Ring (Retaining Washer)	
	OW	Oval Countersunk Wood Screw			W	Flat Washer (Plain)	
SEMS SCREW	BSA	Binding Head SEMS Screw(A Type)			SW	Lock Washer (Spring)	
	BSB	Binding Head SEMS Screw(B Type)			LWI	Lock Washer (Internal Teeth)	
	BSF	Binding Head SEMS Screw(F Type)			LWE	Lock Washer (External Teeth)	
	PSA	Pan Head SEMS Screw(A Type)			TW	Trim Washer (Countersunk)	
	PSB	Pan Head SEMS Screw(B Type)		NUT	N	Hex Nut	