

TEAC[®]

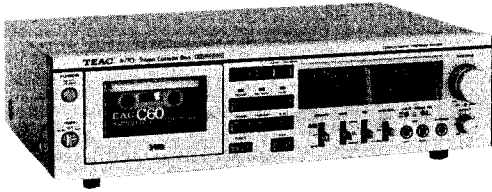

SERVICE MANUAL

A-770

Stereo Cassette Deck

1 SPECIFICATIONS AND SERVICE DATA

SPECIFICATIONS

Track System 4-track, 2-channel stereo

3 Heads Erase, record and playback

Type of Tape Cassette tape, C-60 and C-90 (Phillips type)

Tape Speed 4.8 cm/s (1-7/8 ips)

Input (Level and impedance)

MIC: Specified input level; -57 dB (1.09 mV)/10 kohms
Min. input level; -67 dB (346 μ V)

LINE IN: Specified input level; -9 dB (275 mV)/50 kohms
Min. input level; -19 dB (86.9 mV)

DIN*: Min. input level; -45 dB (4.36 mV)
*Pursuant to DIN standards (Europe model only)

Output (level and load impedance)

OUTPUT: Spec. output level; -5 dB (436 mV)/50 kohms
Max. output level; -3.5 dB (518 mV)

PHONES: Spec. output level; -16 dB (123 mV)/8 ohms

Equalization

METAL: 3180 μ s + 70 μ s

Co (CrO₂): 3180 μ s + 70 μ s

NORMAL: 3180 μ s + 120 μ s

Head Configuration

1/2-track, 1-channel erase head

1/4-track, 2-channel record head and playback head in a single housing

Motor 1 DC servo motor (for capstan drive)

1 DC motor (for reel drive)

Bias Frequency 100 kHz \pm 5 kHz

Operation Position Horizontal

Power Requirements

100/117/220/240V AC, 50/60 Hz, 21W (General Export Model)

117V AC, 60 Hz, 21W (U.S.A./Canada Model)

220V AC, 50 Hz, 21W (Europe Model)

240V AC, 50 Hz, 21W (U.K./Australia Model)

Weight 7.0 kg (15-7/16 lbs.) net

Dimensions See Fig. 1-3

SERVICE DATA

MECHANICAL

Tape Speed Deviation 3,000 Hz \pm 45 Hz

Tape Speed Drift 45 Hz

Wow and Flutter

Playback: 0.07% (WRMS)

Record/Playback: 0.20% (RMS)

Pinch Roller Pressure 350 g to 450 g (12.3 oz to 15.9 oz)

Reel Torque

Take-up: 40 to 65 g-cm (0.56 to 0.90 oz-inch)

Supply: 2 to 6 g-cm (0.028 to 0.083 oz-inch)

F.F.: 120 to 170 g-cm (1.7 to 2.4 oz-inch)

REW: 120 to 170 g-cm (1.7 to 2.4 oz-inch)

Fast Wind Time

95 sec. or less for MTT-501 (C-60)

Auto End-stop Time 2 sec. or less

TIMER activate Time 2.3 sec. \pm 1 sec.

ELECTRICAL

Frequency Response

Playback - Co (CrO₂), METAL

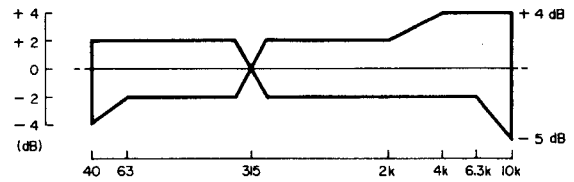

Fig. 1-1

Overall

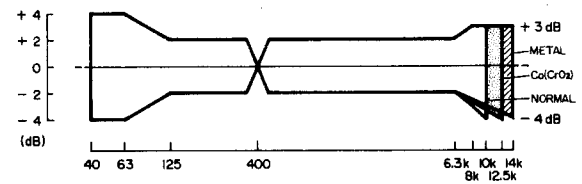

Fig. 1-2

Signal-to-noise Ratio

Playback NORMAL: 46 dB min.

Record/Playback

METAL, Co (CrO₂): 45 dB min.

NORMAL: 43 dB min.

S/N is improved by 5 dB at 1 kHz and 10 dB above 5 kHz when Dolby NR** is used.

Erase Efficiency 65 dB min. at 1 kHz (measured with input 10 dB higher than the specified input level).

Channel Separation 20 dB min. at 1 kHz

Adjacent Track Crosstalk 40 dB min. at 125 Hz

Total Harmonic Distortion 2.2% or less with METAL/Co (CrO₂)
2.5% or less with NORMAL

NOTES:

- Improvements may result in SPECIFICATIONS AND SERVICE DATA changes.
- Value of "dB" in the data refers to 0 dB (0.775 V), except where specified.

** Noise Reduction System manufactured under license from Dolby Laboratories Licensing Corporation. 'Dolby' and the double-D symbol are trademarks of Dolby Laboratories Licensing Corporation.

CAUTION

△ Parts marked with this sign are safety critical components. They must always be replaced with identical components - refer to the TEAC parts list and ensure exact replacement.

2 REMOVAL OF EXTERNAL COMPONENTS

Disassemble in number-order

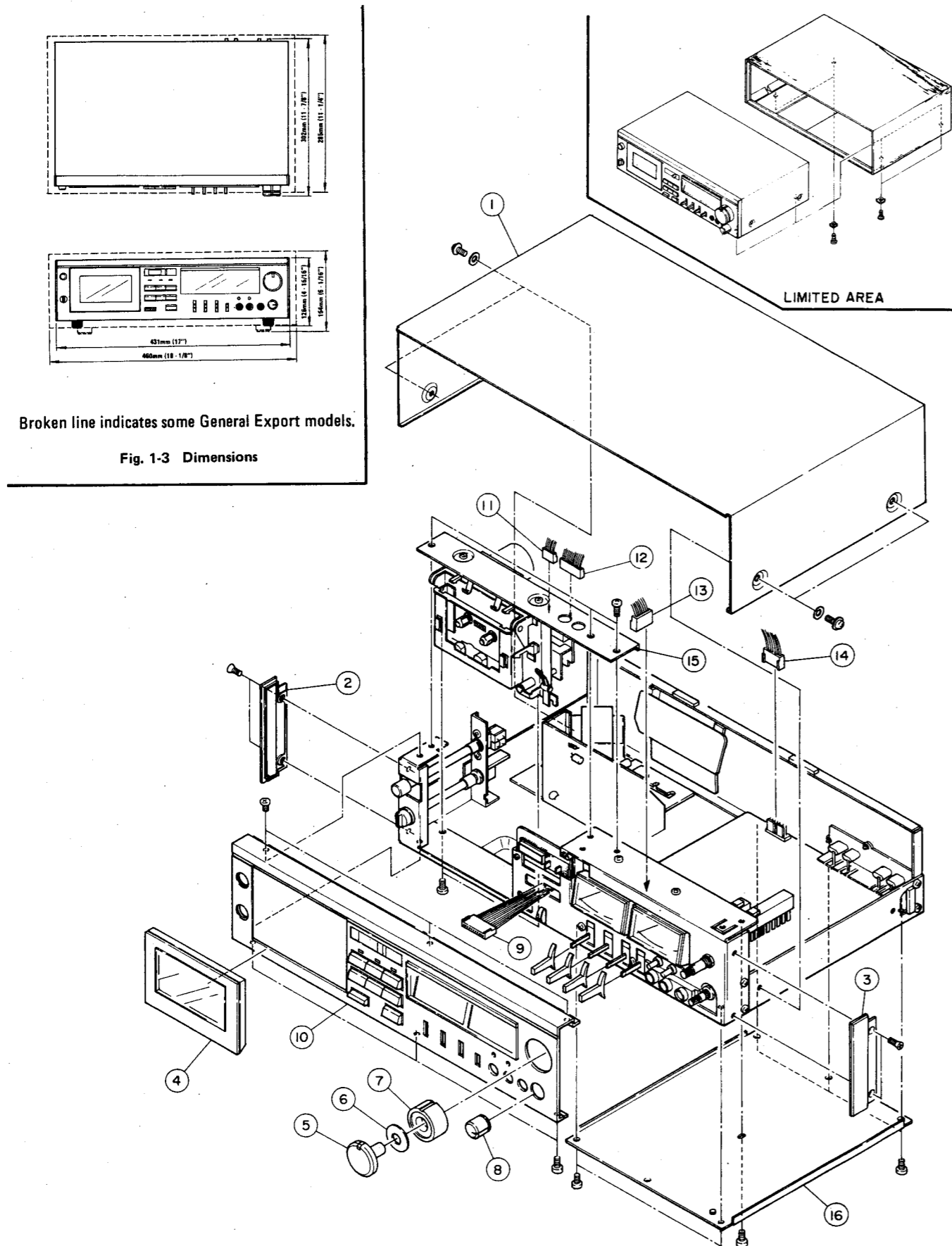

3 PARTS LOCATION

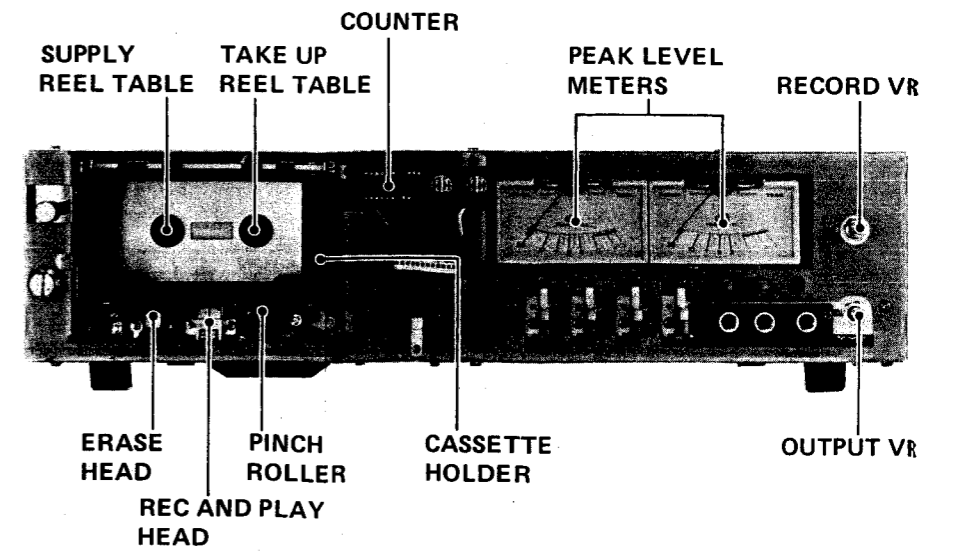
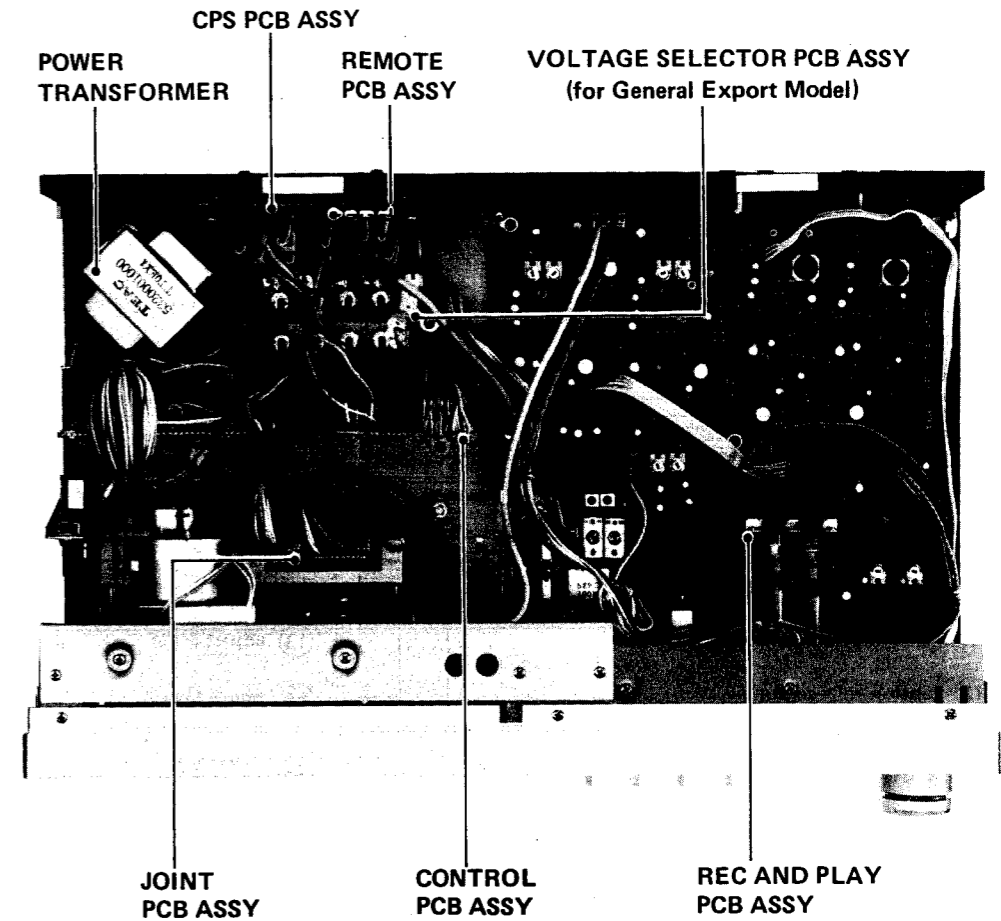

4 MECHANICAL ADJUSTMENTS AND CHECKS

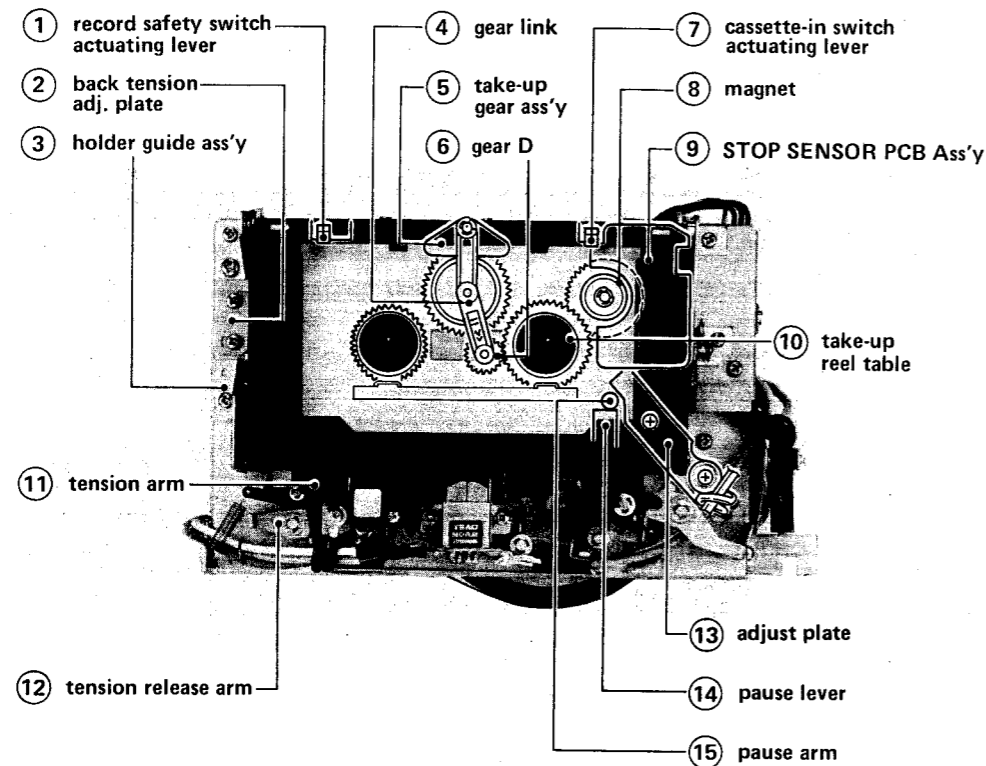

Fig. 4-1

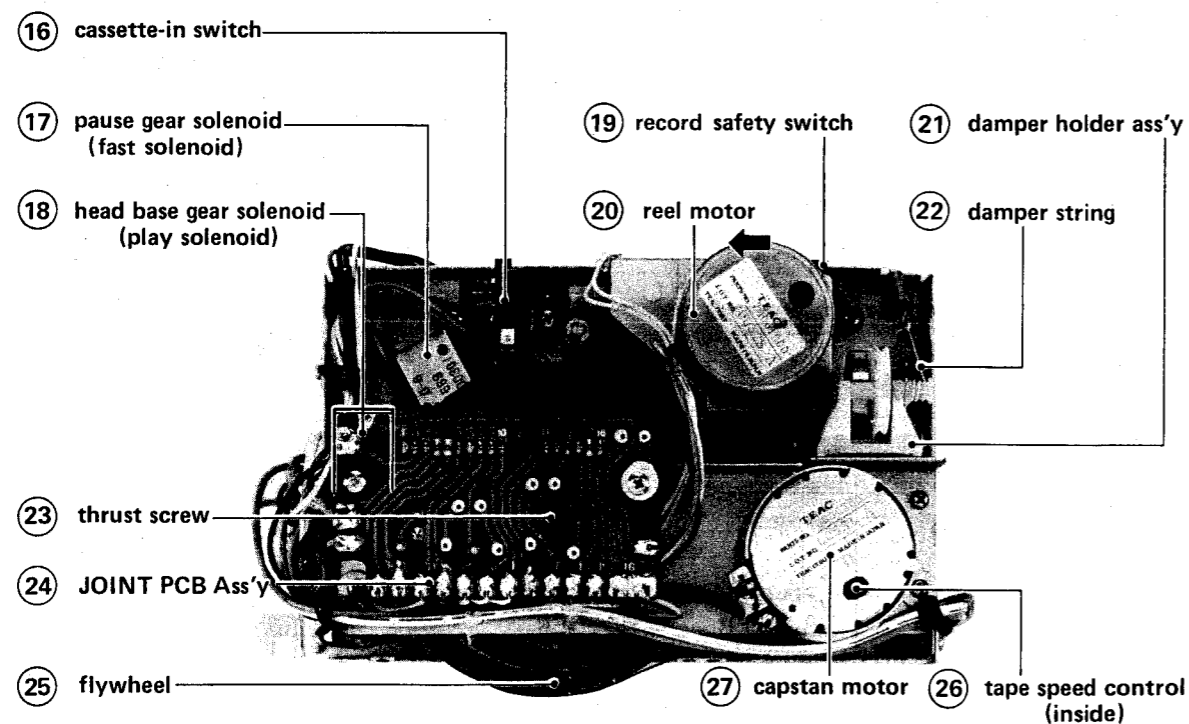

Fig. 4-2

Note: Numbers in brackets are references to corresponding items in Figs. 4-1 and 4-2.

4-1 CAPSTAN ASSEMBLY THRUST

Capstan shaft thrust value: 0.1 mm to 0.2 mm

1. Adjustment can be made by the thrust screw (23).
2. Secure the screw with locking paint.

4-2 PINCH ROLLER PRESSURE

1. With the cassette holder closed and no tape loaded, and while pushing the cassette-in switch's actuating lever (7) upwards, depress the PLAY button.
2. Measure the pinch roller pressure when the pinch roller just begins rotation after it is separated from the capstan shaft in a downward direction.

Pinch roller pressure: 350 g to 450 g (12.3 oz to 15.9 oz)

4-3 REEL TORQUE

1. Load a cassette torque meter and read the pointer indication on the dial scale for each tape movement operation.
 - Take-up: 40 to 65 g-cm (0.56 to 0.90 oz-inch)
 - Supply: 2 to 6 g-cm (0.028 to 0.083 oz-inch)*
 - F.F. & REW: 120 to 170 g-cm (1.7 to 2.4 oz-inch)
- *Values within this range are acceptable; however, an ideal value would be from 3 to 4 g-cm (0.042 to 0.056 oz-inch). It may be possible to achieve this value by adjusting the screws on the back tension adjusting plate (2).

4-4 TAPE SPEED

1. Load and play a TEAC MTT-111 test tape.
2. Using a common slotted screwdriver with the handle completely insulated from the screwdriver blade, adjust the control (26) on the capstan motor (27) (as far as possible) for a reading of 3,000 Hz (Spec: 3,000 Hz \pm 5 Hz).

Note: This tape speed setting should be made after about 20 seconds of operating time.

3. Check the followings at any portion of the tape run.

Specifications:

Tape speed deviation: 3,000 Hz \pm 45 Hz
Tape speed drift: 45 Hz

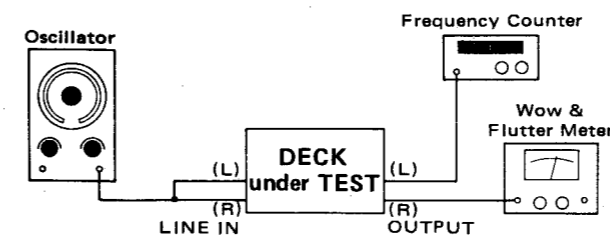

Fig. 4-3

4-5 WOW AND FLUTTER

Note: These measurement should be made at the beginning, middle and the end of the tape.

PLAYBACK METHOD

1. Play a TEAC MTT-111 test tape.
2. Check that the wow and flutter value is within 0.07% WRMS max.

RECORD/PLAYBACK METHOD

Note: Use the maximum wow-and-flutter obtained from repeated measuring, each time stopping then replaying the tape.

3. Load a TEAC MTT-501 test tape (blank).
4. Apply and record a 3,000 Hz signal.
5. Rewind and play this recorded section.
6. Check that the wow and flutter value is within 0.20% RMS max.

4-6 SOLENOIDS

Mount both the pause gear solenoid (17) and head base gear solenoid (18) so that they are positioned as far as possible in the direction of their respective plungers. (For an illustration of the pause gear and the head base gear, see Fig. 4-4).

4-7 TENSION ARM

1. Load a fully erased TEAC MTT-501 test tape fully wound onto the left (or right) reel.
2. Press the PROGRAM count button so that counter indicates any number between 2 to 19.
3. Press the F. FORWARD (▶▶) [or REWIND (◀◀)] button to engage the CPS search operation.
4. The clearance between the tension arm (11) and the moving tape should be 0 to 1 mm.
5. If not, adjust by bending the bent-tip portion of the tension release arm (12) to meet the required clearance value.

4-8 FLYWHEEL, HEAD BASE AND PAUSE GEARS

Position the capstan metal housing so that the flywheel gear (attached to the flywheel shaft) is positioned as far as possible towards the head base gear as shown in Fig. 4-4.

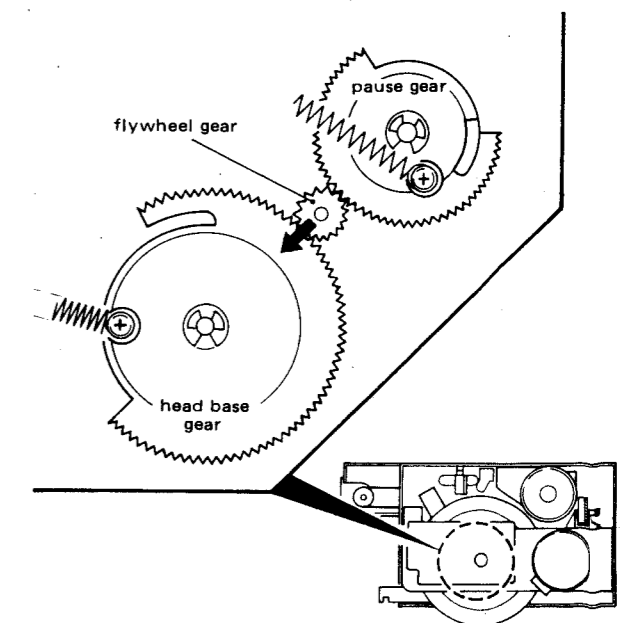

Fig. 4-4

4-9 PINCH ROLLER POSITION

1. By bending the pause lever's bent-tip portion, adjust the pinch roller position to meet the following conditions:
 - a. In the pause mode, the pinch roller/capstan clearance should be about 0.5 mm to 1 mm.
 - b. In play mode, there should be proper clearance between the pinch roller arm pin and the head base's bent-tip portion.

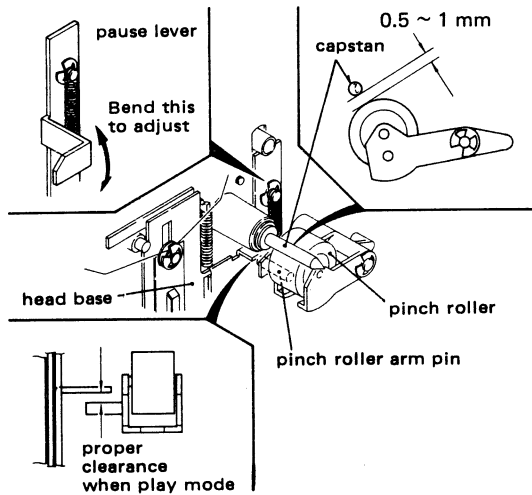

Fig. 4-5

4-10 RECORD SAFETY SWITCH

1. Adjust the record safety switch (19) position to meet the following requirements:
 - a. When any cassette with the corresponding record-protect tab in place is loaded, the deck can go into record mode.
 - b. When any cassette is loaded with the corresponding record-protect tab removed, recording is inhibited.

4-11 CASSETTE-IN SWITCH

1. Adjust the cassette-in switch (16) position to obtain a clearance as illustrated in Fig. 4-6 so that when a cassette is loaded, the transport mechanism is able to go into any tape motion mode.

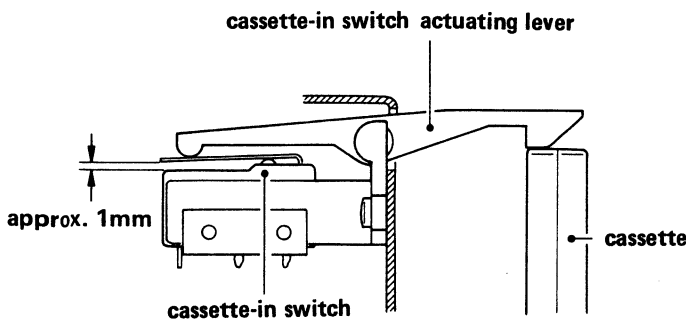

Fig. 4-6

4-12 TAKE-UP GEAR ASSEMBLY

Note: When the pause gear (refer to Fig. 4-4), pause arm (15), adjust plate (13), reel motor (20) and/or take-up gear assembly (5) are reinstalled or replaced, this adjustment must be made.

1. Position the reel motor as far as possible in the direction shown by the arrow in Fig. 4-2.
2. Set the deck to play mode.
3. Check that when pushing the gear link (4) towards the take-up reel table (10), gear D (6) moves 0.1 mm to 0.2 mm towards the reel table.
4. If not, adjust by positioning the adjust plate (13).
5. Check that when securing the take-up reel table, gear D does not disengage from the take-up reel table gear.

4-13 CASSETTE HOLDER

1. Adjust the holder guide assembly position so that when the cassette holder is closed, its back plate is parallel with the tape transport chassis.

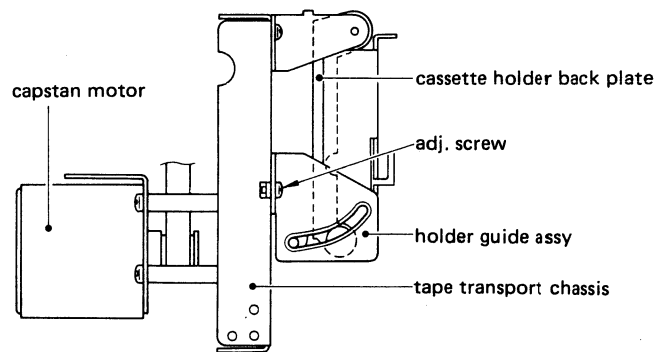

Fig. 4-7

4-14 STOP SENSOR ASS'Y (HALL IC) POSITION

1. Adjust by moving the STOP SENSOR PCB ass'y (9) so that the clearance shown in Fig. 4-8 is approximately 1 mm.
2. Be careful not to change only the position of the HALL IC when making this adjustment.

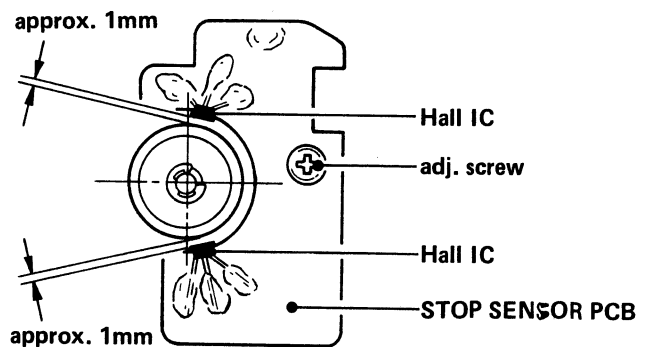

Fig. 4-8

4-15 DAMPER STRING

1. Always wrap the damper string (22) around the drum of the damper holder assembly (21) without twisting it.

4-16 LUBRICATION

Lubrication is only required when parts are replaced. For this purpose, use oil and grease specified below.

Oil: TEAC spindle oil (from TEAC TZ-255 oil kit), Mobil D.T.E. Oil Light, or equivalent.

Grease: ORE-LUBE G1/3 or equivalent

1. Apply a drop of oil with an oil applicator to a point about 1/3 the way down the shaft (from the free end) of the flywheel, then insert the shaft into the capstan housing.
2. Apply a suitable amount of light grease to the well of the flywheel bearing.

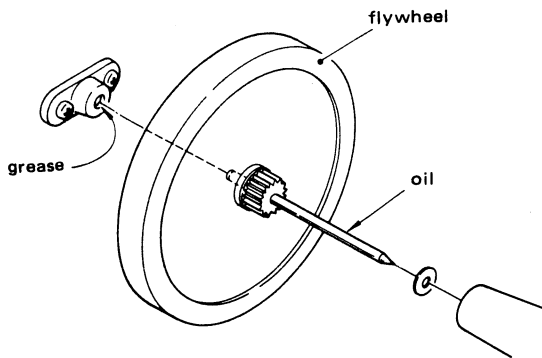

Fig. 4-9

4-17 VOLTAGE CONVERSION (FOR GENERAL EXPORT MODELS)

1. Always disconnect the power line cord before making this adjustment.
2. Remove the cover* of the deck by removing the screws from the sides.
3. Locate the voltage selector (See PARTS LOCATION).
4. Loosen the two screws in the jumper bar and move the bar so that it jumpers the two terminals marked with the required voltage (100, 117, 220 or 240).
5. Retighten the screws and replace the cover*.

* Decks sold in certain areas have a wooden case which must be removed by removing the screws (not the feet) on the bottom of deck before adjusting the voltage.

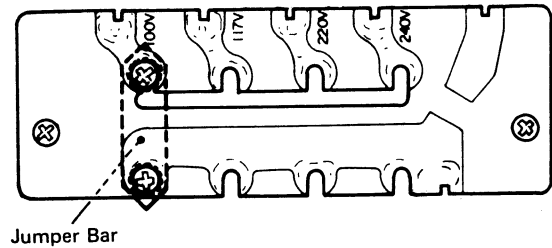

Fig. 4-10

5 ELECTRICAL ADJUSTMENTS AND CHECKS

PRECAUTIONS

1. Before performing adjustments and checks, clean and demagnetize the entire tape path.
2. Make sure the deck is properly set for the voltage in your locality.
3. In general, adjustments and checks are made in the order of L-ch then R-ch. Double REF. NOs. and test point designations indicate L-ch/R-ch. (Example: R11/R21)
4. 0 dB is referenced to 0.775 V. If an AC voltmeter that references 0 dB to 1 V is used, appropriate compensation should be made.
5. The AC voltmeter used in the procedures must have an input impedance of 1M-ohms or more.
6. Note the "Deck settings" at the top of each chart. The settings apply to all checks for a specific chart unless explicitly stated otherwise.

-70 dB or more ... What does it mean?

In reference to some specifications, you may come across an expression like: "-70 dB or more". This means that the lower the value of this specification, the greater the absolute value of the specification and the better the performance of the deck. For instance, a noise floor of -76 dB is better than -70 dB, because this means that the level of noise is lower. So in this case, "-70 dB or more" means at least as good a value as -70 dB and maybe even better, i.e., -71 dB.

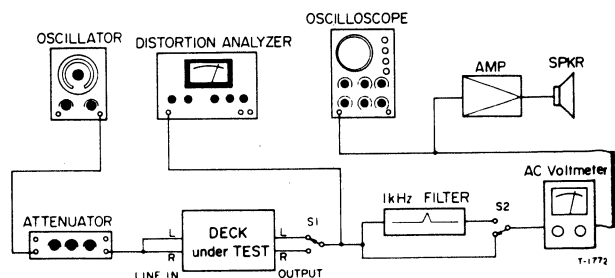

Fig. 5-1 Basic test setup

TEAC test tapes:

- MTT-150: For Dolby level calibration
- MTT-316: For playback frequency response check for METAL, Co (CrO₂)
- MTT-501: For S/N check with NORMAL

- Deck settings:
- EQ sw. —METAL
 - DOLBY NR sw. —OUT
 - MONITOR sw. —TAPE

5-1 PLAYBACK PERFORMANCE

ITEM	INSTRUCTION	INPUT SIGNAL	ADJUST (or CHECK)	MEASURING POINT: RESULT	REMARKS
1. Head azimuth	Conn. — Fig. 5-2 OUTPUT cont. — convenient output level position	MTT-150	Check	OUTPUT: ● Phase: 45° max. on 'scope (Fig. 5-4)	
		MTT-316 (10 kHz)	Azimuth nut of R&P head (Fig. 5-3)	OUTPUT: ● Phase: about 0° ● Max. output at L-& R-ch's on VTVM	
2. Output level	—	MTT-150	R11/R21	DOLBY PLAYBACK TP 580 mV (—2.5 dB)	
	OUTPUT cont. —Max.	MTT-150	Check	OUTPUT: —3.5 dB ±1 dB (461 mV ~ 581 mV)	Max. output level
	—	MTT-150	OUTPUT cont.	OUTPUT: —5 dB (436 mV)	● Spec. setting of OUTPUT cont. ● Spec. output level
IMPORTANT: Do not change the OUTPUT cont. setting after establishing the proper settings as above.					
3. PEAK LEVEL meter	—	MTT-150	R13/R23	PEAK LEVEL meter: 0 dB	
4. Frequency response	—	MTT-316	R12/R22	OUTPUT: See page 2	REF.: 315 Hz
	EQ sw. — NORMAL	MTT-316	Check	OUTPUT: At 10 kHz, should be about 4 dB higher than measured in above step.	
5. Signal-to-noise ratio	EQ sw. — NORMAL	Fully-erased MTT-501 tape (Use bulk tape eraser)	Check	OUTPUT: 46 dB min. ratio	Ratio of spec. output of —5 dB to noise

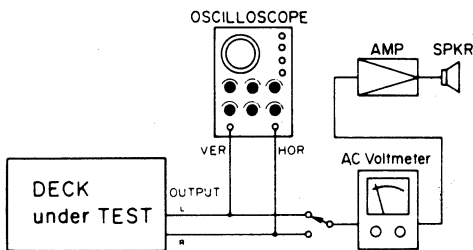

Fig. 5-2 Test setup for azimuth check

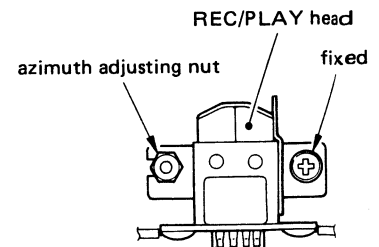

Fig. 5-3 Azimuth nut location

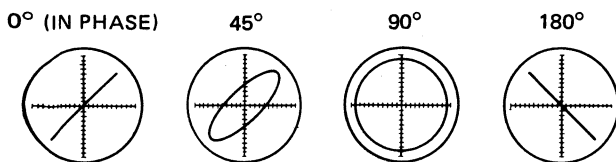

Fig. 5-4 Confirming phase relationship

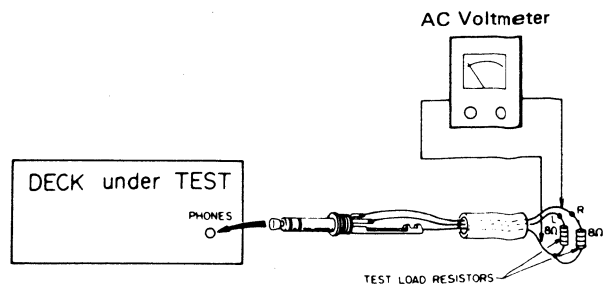

Fig. 5-5 Test setup for headphone check

Deck settings:
REC/PAUSE mode
DOLBY NR sw. -OUT
INPUT sw. -LINE
MONITOR sw. -SOURCE
OUTPUT cont. -Spec. position (item 2)

5-2 MONITOR PERFORMANCE

ITEM	INSTRUCTION	INPUT SIGNAL	ADJUST (or CHECK)	MEASURING POINT: RESULT	REMARKS
6. Min. input level	RECORD cont. - Max. INPUT sw. - MIC	MIC: 400 Hz/-67 dB (346 μV)	Check	OUTPUT: -5 dB ±3 dB (308 mV ~ 615 mV)	MIC min. input level
	INPUT sw. -MIC	DIN IN: 400 Hz/-45 dB (4.36 mV)	Check	OUTPUT: -5 dB ±3 dB (308 mV ~ 615 mV)	DIN min. input level (For European models)
	INPUT sw. - LINE ↓	LINE IN: 400 Hz/- 19 dB (86.9 mV)	Check	OUTPUT: -5 dB ±3 dB (308 mV ~ 615 mV)	LINE min. input level
7. LINE spec. input level	—	LINE IN: 400 Hz/-9 dB (275 mV)	Record cont.	DOLBY RECORD TP 580 mV (-2.5 dB)	Spec. setting of RECORD cont.
	—	LINE IN: 400 Hz/-9 dB (275 mV)	Check	OUTPUT: -5 dB ±1 dB (388 mV ~ 489 mV)	
IMPORTANT: Do not change the RECORD or, OUTPUT control settings after being adjusted above.					
8. PEAK LEVEL meter	—	LINE IN: 400 Hz/-9 dB (275 mV)	Check	PEAK LEVEL meter: 0 dB ±1 dB	
9. Headphone output level	Conn. - Fig. 5-5	LINE IN: 400 Hz/-9 dB (275 mV)	Check	PHONES: -16 dB ±3 dB (86.9 mV ~ 173 mV)	8 ohm load

Deck settings:
DOLBY NR sw. -OUT
INPUT sw. -LINE
OUTPUT cont. -Spec. position (item 2)
RECORD cont. -Spec. position (item 7)

TEAC test tapes:
MTT-5061: For recording test with Co (CrO₂)
MTT-501: For recording test with NORMAL
METAL: For recording test with METAL

5-3 RECORDING PERFORMANCE

ITEM	INSTRUCTION	INPUT SIGNAL	ADJUST (or CHECK)	MEASURING POINT: RESULT	REMARKS
10. Bias trap	Record-pause mode	LINE IN: no signal	L106/L206	BIAS TRAP TP: Min. reading	
11. Record bias	Co (CrO ₂)/MTT-5061 tape	LINE IN: 6.3 kHz/-42 dB (6.15 mV)	C163/C263	OUTPUT: -2.5 dB ±1.5 dB from peak [in excessive bias position]	
12. Record level	Co (CrO ₂)/MTT-5061 tape	LINE IN: 400 Hz/-12 dB (195 mV)	R14/R24	OUTPUT: -8 dB (308 mV)	
	METAL/METAL tape NORMAL/MTT-501	LINE IN: 400 Hz/-12 dB (195 mV)	Check	OUTPUT: -8 dB ±1.0 dB (275 mV ~ 346 mV)	
13. Total harmonic distortion	METAL/METAL tape Co (CrO ₂)/MTT-5061 }.... NORMAL/MTT-501....	LINE IN: 400 Hz/-12 dB (195 mV)	Check	OUTPUT: ...2.2% or less distortion ...2.5% or less distortion	

ITEM	INSTRUCTION	INPUT SIGNAL	ADJUST (or CHECK)	MEASURING POINT: RESULT	REMARKS
14. Frequency response	METAL/METAL tape Co (CrO ₂)/MTT-5061 NORMAL/MTT-501	LINE IN: Required signal/ -42 dB (6.15 mV)	METAL L104/L204 Co (CrO ₂) L103/L203 NORMAL check	OUTPUT: See: page 2	REF.: 400 Hz
15. Signal-to-noise ratio	METAL/METAL tape } Co (CrO ₂)/MTT-5061 }... NORMAL/ MTT-501 ... }	LINE IN: 1 kHz/-9 dB (275 mV) ↓ no signal	Check	OUTPUT: 45 dB min. ratio 43 dB min. ratio	Ratio of spec. output of -5 dB to noise
16. Erase efficiency	<ul style="list-style-type: none"> • Connection is same as in Fig. 5-1, but engage 1-kHz filter. • Record a 1-kHz signal. Rewind tape to midpoint of recorded portion. Record a "no signal" portion. Find the difference between the 1-kHz portion and the "no-signal" portion. 				
	METAL /METAL tape	LINE IN: 1 kHz/+1 dB (0.869V) ↓ no signal	Check	OUTPUT: 65 dB min. ratio	
17. REC MUTE function	<ul style="list-style-type: none"> • Connection: Fig. 5-1, but engage 1-kHz filter. • Record a 1-kHz signal. Push REC MUTE button for several seconds. Rewind and play the tape. Find the difference between the 1-kHz portion and the "no-signal" portion. 				
	Co (CrO ₂)/MTT-5061	LINE IN: 1 kHz/+1 dB (0.869V) ↓ no signal	Check	OUTPUT: 65 dB min. ratio	
18. Channel separation	<ul style="list-style-type: none"> • Connection: Fig. 5-1, but do not connect LINE IN (R), and engage 1-kHz filter. • Set the deck to record mode. Find the difference between the 1-kHz recorded portion (L-ch) and the "no signal" portion (R-ch). 				
	Co (CrO ₂)/MTT-5061	LINE IN: L-ch 1- kHz/-9 dB (275 mV) R-ch No signal	Check	OUTPUT: 20 dB min. ratio	
19. Adjacent track crosstalk	<ul style="list-style-type: none"> • Connection: Fig. 5-1, but do not connect LINE IN (L) and OUTPUT (L). • Record a 125-Hz signal on R-ch and note output level. Invert tape and play R-ch track. Check leakage level against the output reference of previously recorded portion. 				
	Co (CrO ₂)/MTT-5061	LINE IN: L-ch No signal R-ch 125 Hz/-9 dB (275 mV)	Check	OUTPUT: 40 dB min. ratio	
20. Dolby NR effect	<ul style="list-style-type: none"> • Record a 1-kHz signal with Dolby NR switch OUT. Play this portion with Dolby NR switch set to OUT and set to IN. Obtain the difference in output level between OUT and IN positions. Repeat the above process using a 10-kHz signal. 				
	Co (CrO ₂)/MTT-5061	LINE IN: 1 kHz/-29 dB (27.5 mV)	Check	OUTPUT: Variation 3 dB ~ 8 dB	
	Co (CrO ₂)/MTT-5061	LINE IN: 10 kHz/-39 dB (8.69 mV)	Check	OUTPUT: Variation 8 dB ~ 12 dB	

5-4 ADJUSTMENT AND TEST POINT LOCATIONS

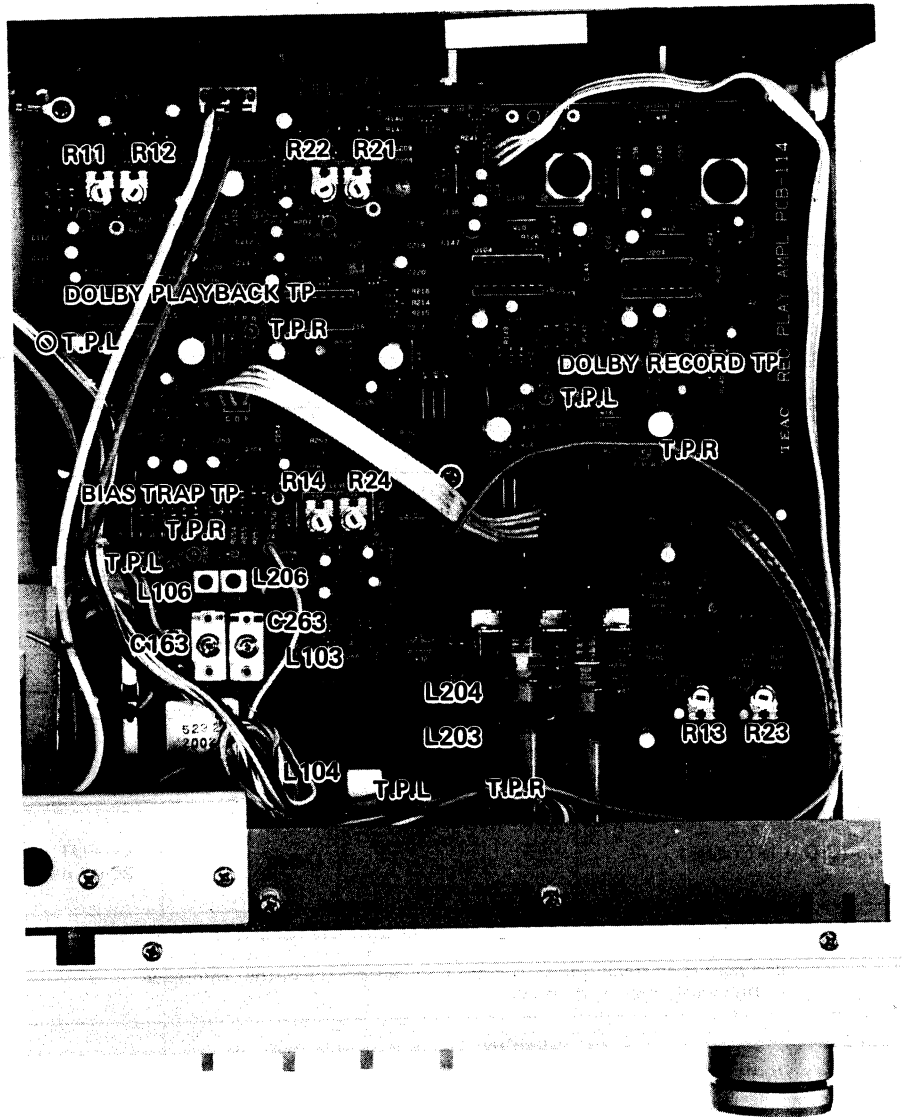
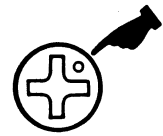

Fig. 5-6

C163/C263	Record bias [Co (CrO ₂)]
L103/L203	Record frequency response [Co (CrO ₂)]
L104/L204	Record frequency response [METAL]
L106/L206	Bias trap
R11/R21	Output level
R12/R22	Playback frequency response
R13/R23	Peak level meter
R14/R24	Record level [Co (CrO ₂)]

ASSEMBLING HARDWARE CODING LIST

All screws conform to ISO standards, and have crossrecessed heads, unless otherwise noted. ISO screws have the head inscribed with a point as in the figure to the right.



FOR EXAMPLE:

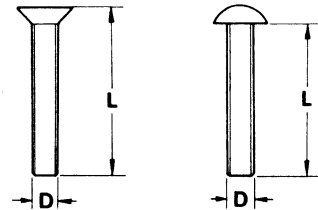
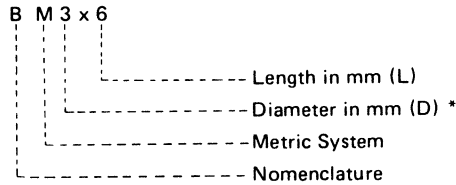

* Inner dia. for washers and nuts

	<i>Code</i>	<i>Name</i>	<i>Type</i>		<i>Code</i>	<i>Name</i>	<i>Type</i>
MACHINE SCREW	R	Round Head Screw		TAPPING SCREW	BTA	Binding Head Tapping Screw(A Type)	
	P	Pan Head Screw			BTB	Binding Head Tapping Screw(B Type)	
	T	Stove Head Screw (Truss)			RTA	Round Head Tapping Screw(A Type)	
	B	Binding Head Screw			RTB	Round Head Tapping Screw(B Type)	
	F	Flat Countersunk Head Screw		SETSCREW	SF	Hex Socket Setscrew(Flat Point)	
	O	Oval Countersunk Head Screw			SC	Hex Socket Setscrew(Cup Point)	
WOOD SCREW	RW	Round Head Wood Screw		SS	Slotted Socket Setscrew(Flat Point)		
TAPTITE SCREW	PTT	Pan Head Taptite Screw		WASHER	E	E-Ring (Retaining Washer)	
	WTT	Washer Head Taptite Screw			W	Flat Washer (Plain)	
SEMS SCREW	BSA	Binding Head SEMS Screw(A Type)			SW	Lock Washer (Spring)	
	BSB	Binding Head SEMS Screw(B Type)			LWI	Lock Washer (Internal Teeth)	
	BSF	Binding Head SEMS Screw(F Type)			LWE	Lock Washer (External Teeth)	
	PSA	Pan Head SEMS Screw(A Type)		TW	Trim Washer (Countersunk)		
	PSB	Pan Head SEMS Screw(B Type)		NUT	N	Hex Nut	

6 EXPLODED VIEWS AND PARTS LIST

EXPLODED VIEW - 1

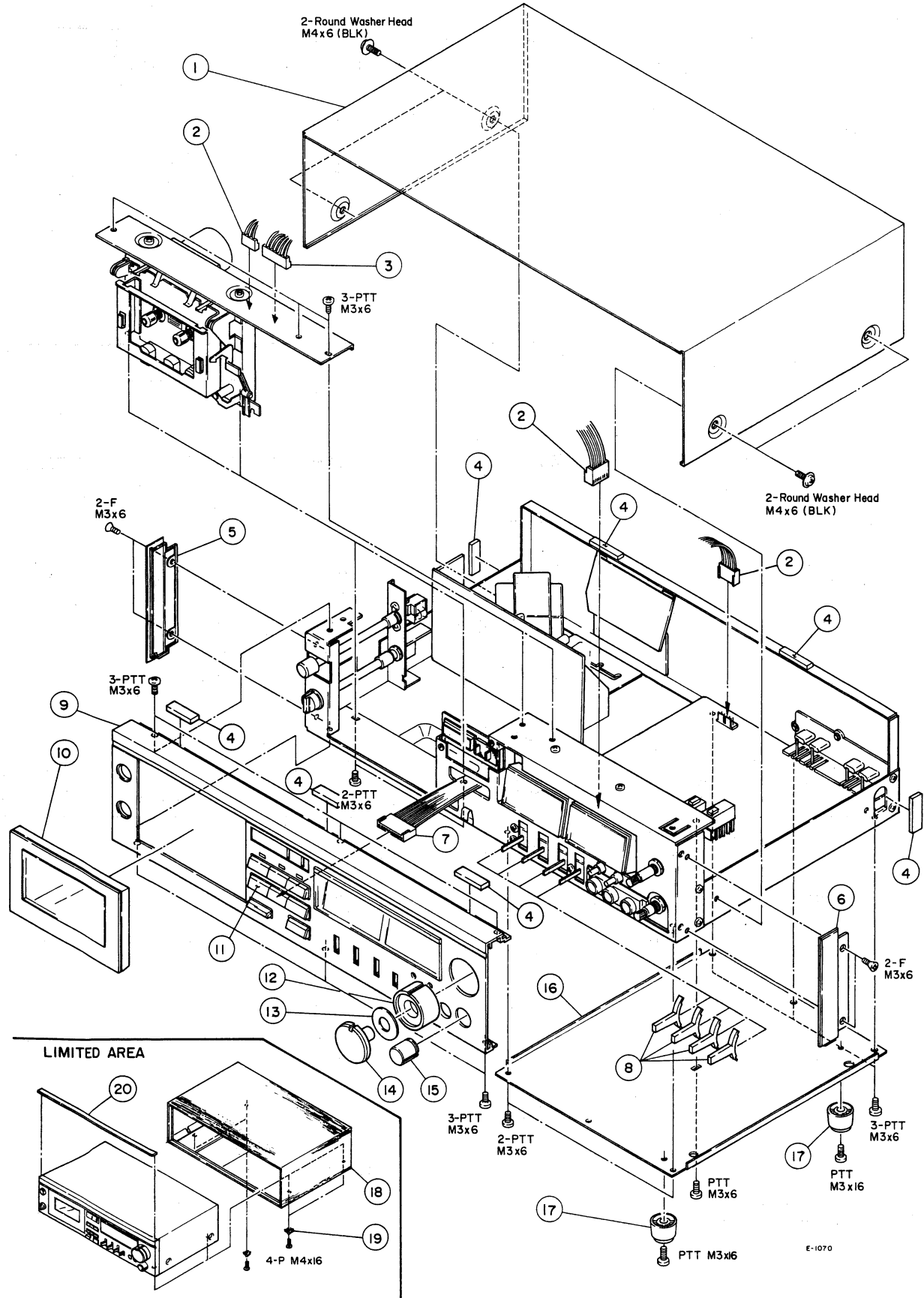

Parts marked with *require longer delivery time.

REF. NO.	PARTS NO.	DESCRIPTION	REMARKS
1 - 1	*5800042600	Cover, Top [All except L]	A-660
	*5800056400	Cover, Top [L]	A-660
1 - 2	*5122168000	Connector Socket, 6P	
1 - 3	*5122172000	Connector Socket, 10P	
1 - 4	*5555570000	Cushion, Top Cover; B	A-500
1 - 5	*5800042700	Cover, Side; L	A-660
1 - 6	*5800042800	Cover, Side; R	A-660
1 - 7	*5122174000	Connector Socket, 12P	
1 - 8	5800044400	Knob, Lever Switch	A-660
1 - 9	5640005600	Panel Assy, Front; D	
1 - 10	5640005700	Cover Assy, Cassette	
1 - 11	5301852500	Key Unit	A-660
1 - 12	5800011800	Knob, REC; B	A-350
1 - 13	*5800025400	Washer, Felt	A-350
1 - 14	5800011700	Knob, REC; A	A-350
1 - 15	5800011900	Knob, VR	A-350
1 - 16	*5800038600	Cover, Bottom [All except L]	A-660
	*5800053300	Cover, Bottom [L]	A-660
1 - 17	*5730000200	Foot [All except L]	A-660
1 - 18	*5800055601	Cabinet Assy [L]	
1 - 19	*5555526000	Washer [L]	
1 - 20	*5800143400	Cushion	

INCLUDED ACCESSORIES

REF. NO.	PARTS NO.	DESCRIPTION	REMARKS
	5700005400	Owner's Manual [U]	
	5700005500	Owner's Manual [All except U, L]	
	5101345000	Information Supplement, Cassette [U]	
	5101495000	Information Supplement, Cassette [All except U, L]	
	5128107000	Cord, In-output Connection	

[U]: U.S.A.
 [C]: CANADA
 [GE]: GENERAL EXPORT
 [A]: AUSTRALIA
 [E]: EUROPE
 [UK]: U.K.
 [L]: LIMITED AREA

EXPLODED VIEW - 2

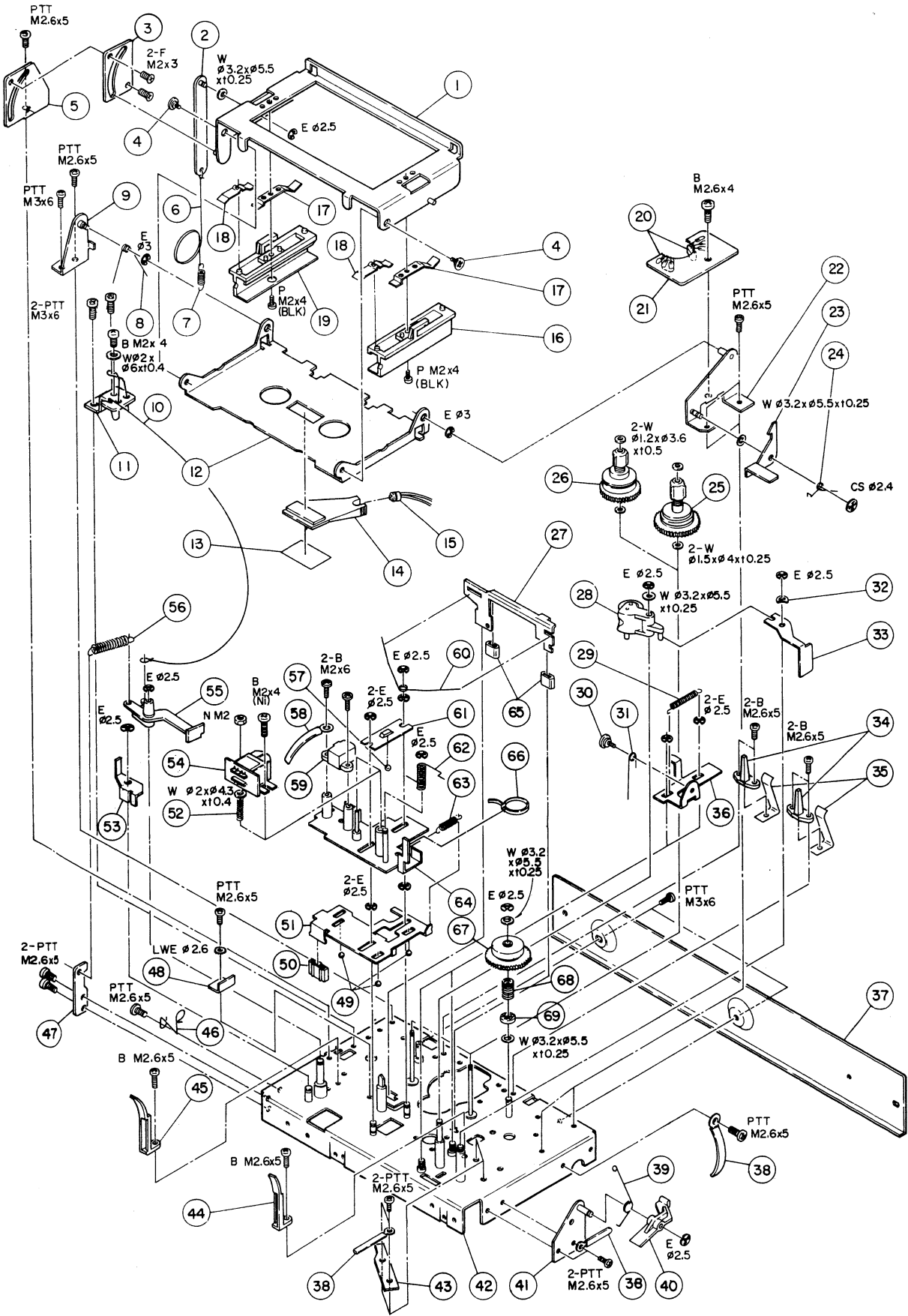

Parts marked with *require longer delivery time.

REF. NO.	PARTS NO.	DESCRIPTION	REMARKS
2 - 1	*5800030402	Holder Assy, Cassette	A-660
2 - 2	*5800030100	Plate Assy, Damper	A-660
2 - 3	*5800103200	Guide, Holder; B	
2 - 4	*5545159000	Screw, Shoulder	C-2
2 - 5	*5800103100	Guide, Holder; A	
2 - 6	*5788202100	Thread, Dial	
2 - 7	*5524203000	Spring, Damper	A-500
2 - 8	*5800040801	Spring, Holder Push; L	A-660
2 - 9	*5800027901	Bracket Assy, Holder; L	A-660
2 - 10	*5788200200	Thread, Dial	
2 - 11	*5800045000	Plate, Tension Adjusting	
2 - 12	*5800034200	Plate, Cassette	A-660
2 - 13	*5800002900	Plate, Reflective	C-2
2 - 14	*5800033300	Lens, Lamp	A-660
2 - 15	5142201000	Lamp, DC 6V 65mA	
2 - 16	5800034001	Guide, Cassette; R	A-660
2 - 17	*5800103300	Spring, Cassette Pressure; A	
2 - 18	*5800103400	Spring, Cassette Pressure; B	
2 - 19	5800034101	Guide, Cassette; L	A-660
2 - 20	*5228700200	Hole IC, DN6838	
2 - 21	*5210037500	PCB, STOP SENSOR	
2 - 22	*5800027501	Bracket Assy, Holder; R	A-660
2 - 23	*5800033200	Plate, Holder Lock	A-660
2 - 24	*5800040601	Spring, Holder Lock	A-660
2 - 25	5800025900	Reel Table Assy, Take-up	A-660
2 - 26	5800038400	Reel Table Assy, Supply	
2 - 27	*5800103500	Plate, Brake; B	
2 - 28	5800029600	Arm Assy, Pinch Roller	A-660
2 - 29	*5800040200	Spring, Pause Lever	A-660
2 - 30	*5581057000	Screw, Shoulder; B	A-660
2 - 31	*5800040100	Spring, REC Lock	A-660
2 - 32	*5555352000	Washer, Wave	
2 - 33	*5800034301	Arm, Eject Preventing	A-660
2 - 34	*5800033500	Stopper, Cassette	
2 - 35	*5800033400	Spring, Cassette Pressure	
2 - 36	*5800035400	Lever, Pause	
2 - 37	*5800041002	Bracket, Mechanism	
2 - 38	*5581038000	Clamper, Cord; A	A-660
2 - 39	*5800126000	Spring, Earth	
2 - 40	*5800034400	Arm, Eject	A-660
2 - 41	*5800126200	Plate Assy, Eject	
2 - 42	*5800045700	Chassis Assy, Mechanism	
2 - 43	*5800089901	Plate, Adjust	A-660
2 - 44	*5800103000	Guide, Cassette; R	
2 - 45	*5800102900	Guide, Cassette; L	
2 - 46	*5800124900	Harness Clip	
2 - 47	*5800045100	Plate, Tension	
2 - 48	*5800035800	Stopper, Head Base	A-660
2 - 49	5540056000	Steel Ball, ϕ 3	A-450
2 - 50	*5534259000	Cushion	A-660
2 - 51	*5800035901	Sub Plate Assy, Head Base	A-660
2 - 52	*5520002100	Spring, Head Adjusting	A-450
2 - 53	*5800056500	Plate, Tension Cancel	
2 - 54	5378600000	Head, REC-PLAY	
2 - 55	*5533174000	Arm, Tension	A-300
2 - 56	*5524208000	Spring, Tension	A-300
2 - 57	5540055000	Steel Ball, ϕ 2	
2 - 58	*5581062000	Clamper, Cord; E	
2 - 59	5569613000	Head, Erase	C-3
2 - 60	*5800040000	Spring, Brake	A-660
2 - 61	*5800035700	Guide, Steel Ball	A-660
2 - 62	*5800123800	Spring, Pinch Roller; B	
2 - 63	*5800039402	Spring, Head Base Pressure	A-660
2 - 64	*5800045200	Plate Assy, Head Base; A	A-660
2 - 65	*5800103600	Shoe, Brake	A-660
2 - 66	*5786720100	Clamper, Cord; BK-1 (BLK)	

Continued on page 19

EXPLODED VIEW - 3

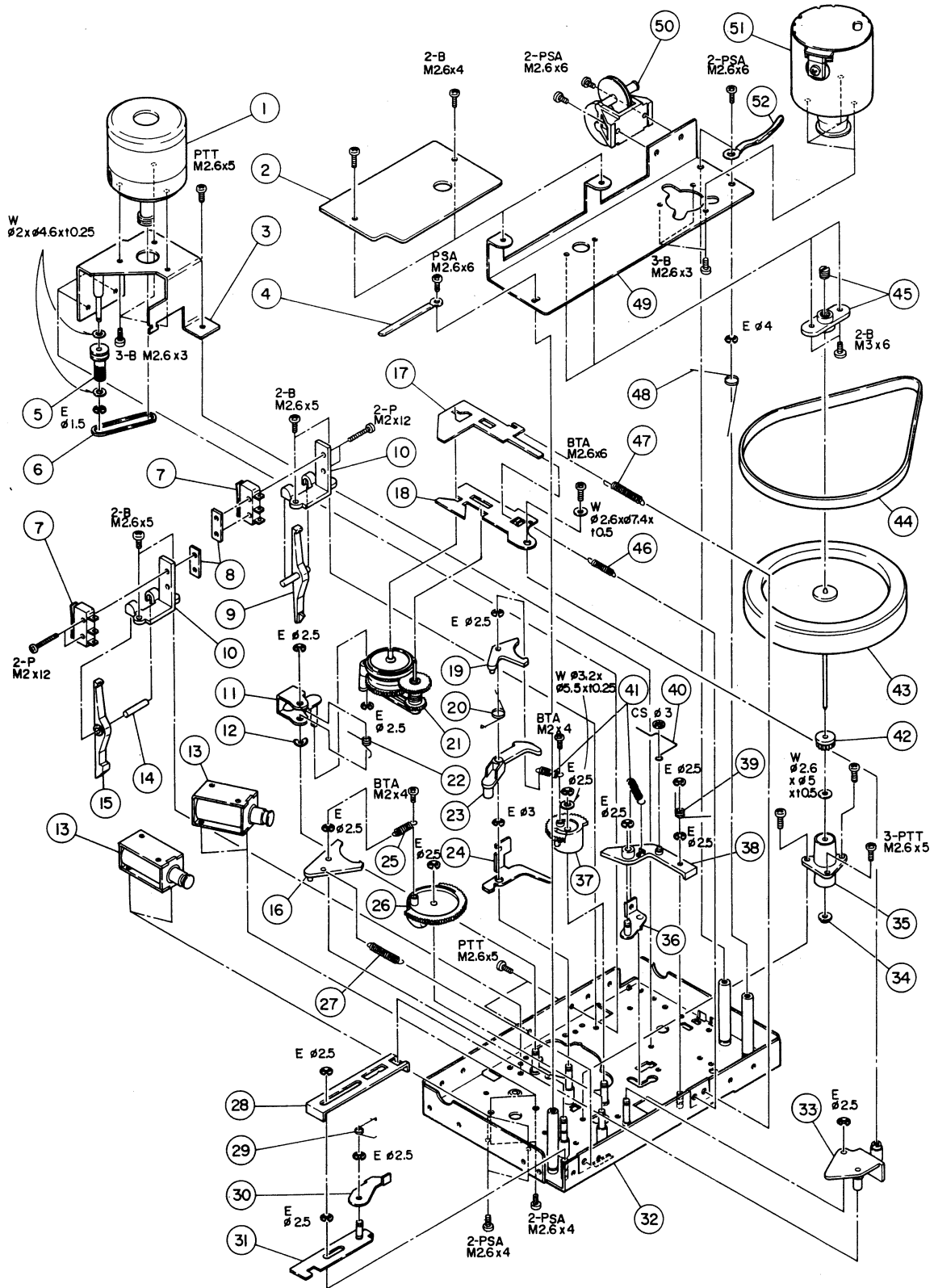

Parts marked with *require longer delivery time.

REF. NO.	PARTS NO.	DESCRIPTION	REMARKS
3 - 1	5370001000	Motor Assy, Reel	
3 - 2	*5200037700	PCB Assy, JOINT	
3 - 3	*5800082701	Bracket Assy, Reel Motor	A-660
3 - 4	*5581038000	Clamper, Cord; A	
3 - 5	5800123600	Pulley Assy, Relay	
3 - 6	5800104100	Belt, Reel	A-660
3 - 7	*5301455300	Switch, Micro	
3 - 8	*5554447000	Plate, Micro Switch	A-400
3 - 9	*5800034600	Lever, Switch; A	A-660
3 - 10	*5800034500	Holder, Switch	A-660
3 - 11	*5800083102	Arm Assy, Relay Gear	A-660
3 - 12	*5555352000	Washer, Wave	
3 - 13	5313000301	Solenoid	
3 - 14	*5800055900	Shaft, Switch Lever	A-660
3 - 15	*5800034700	Lever, Switch; B	A-660
3 - 16	*5800037300	Arm, Play Lock	A-660
3 - 17	*5800036801	Plate, Gear Guide; B	
3 - 18	*5800036701	Plate, Gear Guide; A	
3 - 19	*5800037000	Arm, FF Lock	A-660
3 - 20	*5800045901	Spring, FF Lock	A-660
3 - 21	5800082302	Gear Assy, Take-up	A-660
3 - 22	*5800083300	Spring, Relay Pulley	A-660
3 - 23	*5800035301	Arm, Pause	A-660
3 - 24	*5800037401	Plate, Reel Gear Guide	A-660
3 - 25	*5800039501	Spring, Head Base Gear	A-660
3 - 26	5800037202	Gear, Head Base	A-660
3 - 27	*5800072300	Spring, Play Lock Arm	A-660
3 - 28	*5800035100	Lever, REC; A	A-660
3 - 29	*5800040300	Spring, REC Lock Lever	A-660
3 - 30	*5800035200	Lever, REC Lock	A-660
3 - 31	*5800029801	Lever Assy, REC Lock; B	A-660
3 - 32	*5800045700	Chassis Assy, Mechanism	A-660
3 - 33	*5800036901	Arm, Play	A-660
3 - 34	*5534130000	Washer, Oil Retaining	A-400
3 - 35	5800028500	Housing Assy, Capstan	A-660
3 - 36	*5800028702	Arm Assy, Brake Actuating; B	A-660
3 - 37	5800037102	Gear, Pause	A-660
3 - 38	*5800036600	Arm Assy, Brake Actuating; A	A-660
3 - 39	*5800045800	Spring, Brake Actuating Arm	A-660
3 - 40	*5800035600	Bar, Brake Actuating	A-660
3 - 41	*5800039600	Spring, Pause Gear	A-660
3 - 42	5800036000	Gear, Flywheel	A-660
3 - 43	5800029101	Flywheel Assy	A-660
3 - 44	5534504000	Belt	C-1
3 - 45	*5534277000	Bearing Assy, Thrust	A-400
3 - 46	*5800039701	Spring, Gear Guide Plate; A	A-660
3 - 47	*5800039800	Spring, Gear Guide Plate; B	A-660
3 - 48	*5800039302	Spring, Head Base	A-660
3 - 49	*5800036101	Bracket, Flywheel	A-660
3 - 50	*5800084300	Damper Assy	A-660
3 - 51	5370000300	Motor Assy, Capstan	A-660
3 - 52	5581038000	Clamper, Cord; A	

Continued from page 17

REF. NO.	PARTS NO.	DESCRIPTION	REMARKS
2 - 67	*5800124000	Gear Assy, Counter	
2 - 68	*5800124300	Spring, Tension	
2 - 69	*5800124200	Support, Spring	

EXPLODED VIEW - 4

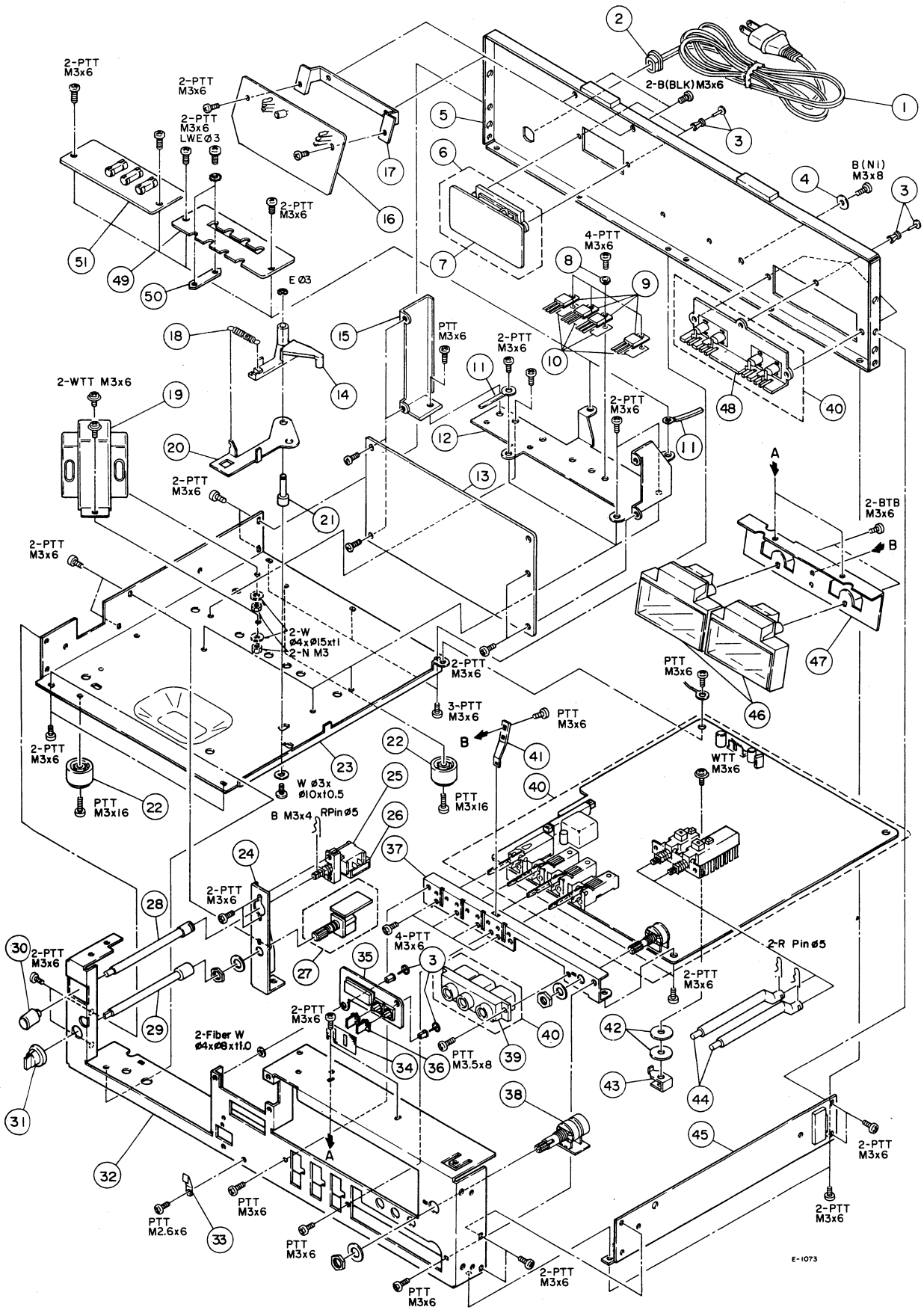

E-1073

Parts marked with *require longer delivery time.

REF. NO.	PARTS NO.	DESCRIPTION	REMARKS
4 - 1	△ 5128034000	Cord, AC Power [GE, L]	
	△ 5128036000	Cord, AC Power [UK]	
	△ 5128075000	Cord, AC Power [U, C]	
	△ 5350008200	Cord, AC Power [E]	
	△ 5350008300	Cord, AC Power [A]	
4 - 2	*5534660000	Strain Relief, AC Power Cord [All except UK]	
	*5534661000	Strain Relief, AC Power Cord [UK]	
4 - 3	*5534118000	Rivet, Push	A-400
4 - 4	*5555063000	Washer, GND	
4 - 5	*5800038901	Panel, Rear	A-660
4 - 6	*5620010400	Connector Assy, REMOTE	
4 - 7	*5200008900	PCB Assy, REMOTE	
4 - 8	*5033295000	Tube, Insulating	
4 - 9	*5231755100	Transistor, 2SD880Y	
4 - 10	*5033291000	Plate, Insulating	
4 - 11	*5581038000	Clamper, Cord; A	
4 - 12	*5800042401	Bracket, PCB; A	A-660
4 - 13	*5200008704	PCB Assy, CONTROL	
4 - 14	*5800057400	Arm, REC; C	
4 - 15	*5800042501	Bracket, PCB; B	A-660
4 - 16	*5200030901	PCB Assy, CPS102	
4 - 17	*5800009300	Bracket, Fuse	A-350
4 - 18	*5800129300	Spring, REC Lever	
4 - 19	△ *5320001000	Transformer, Power [GE, L]	A-660
	△ *5320001100	Transformer, Power [U, C]	A-660
	△ *5320001200	Transformer, Power [E, UK, A]	A-660
4 - 20	*5800041700	Sub Arm, REC	A-660
4 - 21	*5800042000	Shaft, REC Arm	A-660
4 - 22	5730000200	Foot [All except L]	A-660
4 - 23	*5800038800	Chassis, Left [All except L]	A-660
	*5800053200	Chassis Assy, Left [L]	A-660
4 - 24	*5800042300	Bracket, SW	A-660
4 - 25	△ 5134009000	Switch, Push; Power [GE, L]	
	△ 5134018000	Switch, Push; Power [U]	
	△ 5134044000	Switch, Push; Power [E, UK, A]	
4 - 26	△ 5052907000	Spark Killer, 0.1 μ F + 300 Ω /300V [GE, L]	
	△ 5052910000	Spark Killer, 0.033 μ F + 120 Ω /125V [U]	
	△ 5052911000	Spark Killer, 0.033 μ F + 120 Ω /250V [C]	
	△ 5267702500	Spark Killer, 0.0047 μ F/250V [E, UK, A]	
4 - 27	*5200008800	PCB Assy, TIMER	
4 - 28	*5800008300	Bar, Power Switch	A-350
4 - 29	*5800046900	Rod, B	A-660
4 - 30	5800044200	Knob, Power Switch	A-660
4 - 31	5800044300	Knob, Timer Switch	A-660
4 - 32	*5800039001	Chassis, Front	A-660
4 - 33	*5800057300	Spring, Grounding	A-660
4 - 34	*5800124400	Mask, Switch	
4 - 35	*5200009301	PCB Assy, COUNTER	
4 - 36	5800008500	Knob	A-350
4 - 37	*5800042202	Bracket, Switch	A-660
4 - 38	*5200009200	PCB Assy, VR	
4 - 39	*5124063000	Jack Assy, 3-gang	
4 - 40	*5200009100	PCB Assy, REC/PLAY AMPL [All except E]	
	*5200009110	PCB Assy, REC/PLAY AMPL [E]	
4 - 41	*5800108600	Plate, Reinforcing	
4 - 42	*5785245000	Washer, Bakelite; ϕ 4 x ϕ 12 x t1	
4 - 43	*5555059100	Bracket.	A-200
4 - 44	*5800042102	Knob, Select	A-660
4 - 45	*5800038700	Chassis, Right	A-660
4 - 46	5296000700	Meter, Peak Level	A-660
4 - 47	*5800041501	Bracket, Meter	A-660
4 - 48	*5126037000	Terminal Assy, In-output [E]	
	*5126038000	Terminal Assy, In-output [All except E]	
4 - 49	*5168548100	PCB Assy, VOLTAGE SELECTOR [GE, L]	
4 - 50	*5555062000	Bar, Shorting; A [GE, L]	
4 - 51	*5200006000	PCB Assy, FUSE [E, UK]	A-660

[U]: U.S.A.
[C]: CANADA
[GE]: GENERAL EXPORT [E]: EUROPE
[A]: AUSTRALIA [UK]: U.K.
[L]: LIMITED AREA

7 PC BOARDS AND PARTS LIST

PC Boards shown viewed from foil side.

REC/PLAY AMPL PCB ASSY

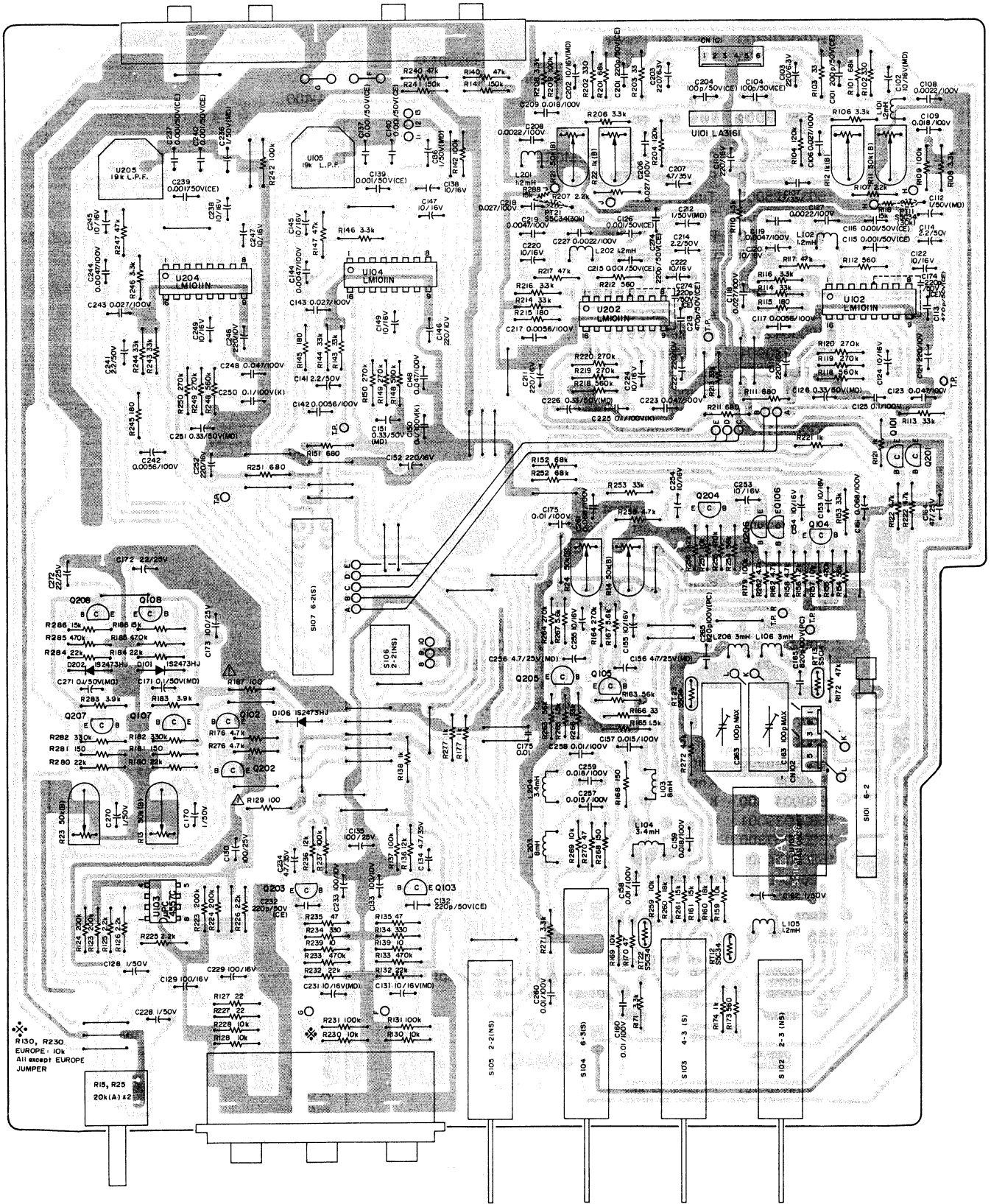

CONTROL PCB ASSY

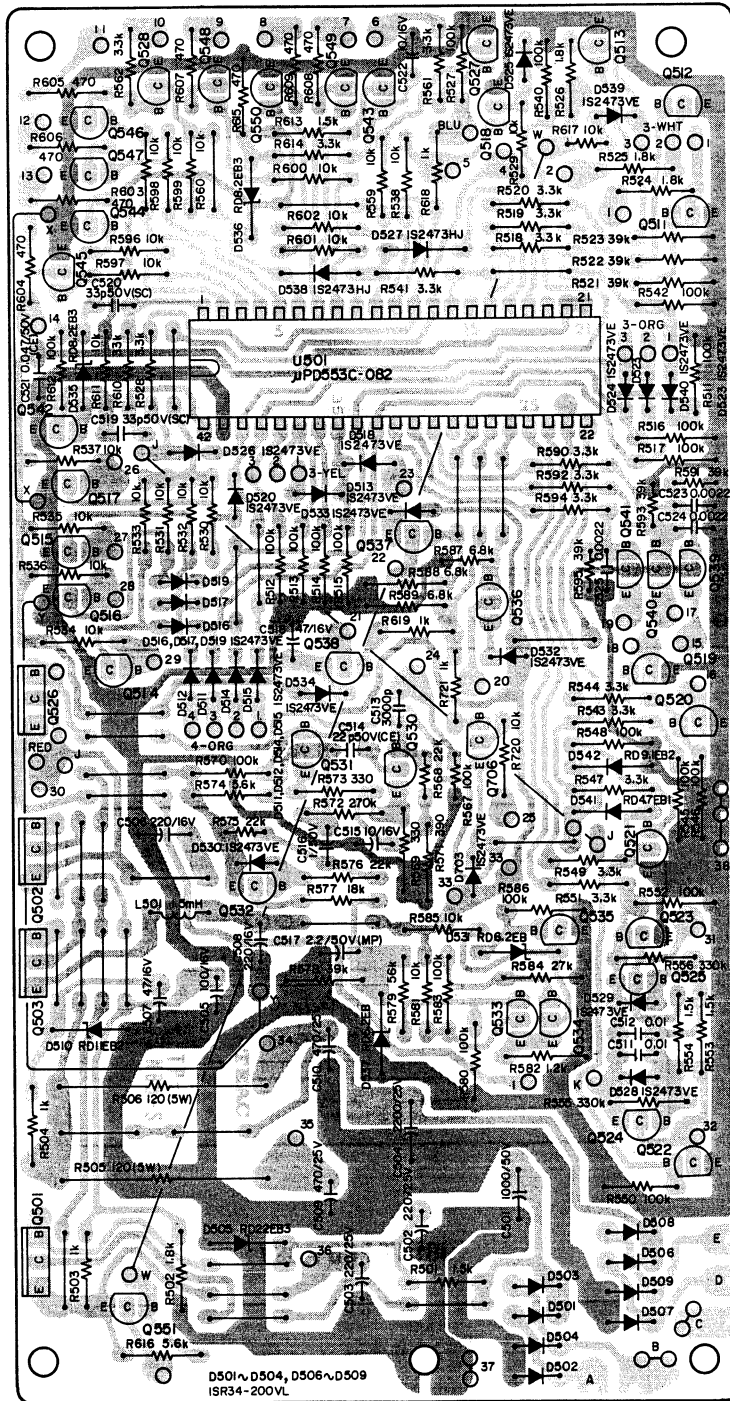

NOTES

1. PC Boards shown viewed from foil side.
2. The colors used on the PCB illustrations have the following significance:
 - Light Gray : +B power supply circuit
 - Dark Gray : GND
 - White : Other
3. Resistor values are in ohms (k = 1,000 ohms).
4. All capacitor values are in microfarads (p = picofarads).

TIMER PCB ASSY

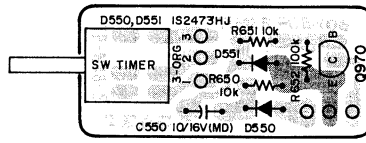

CPS PCB-102 ASSY

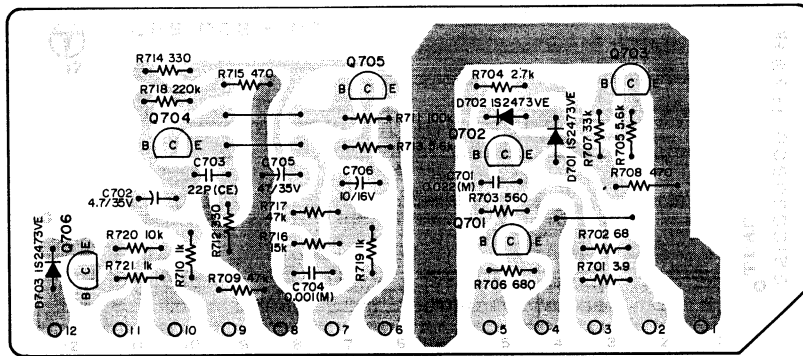

REMOTE PCB ASSY

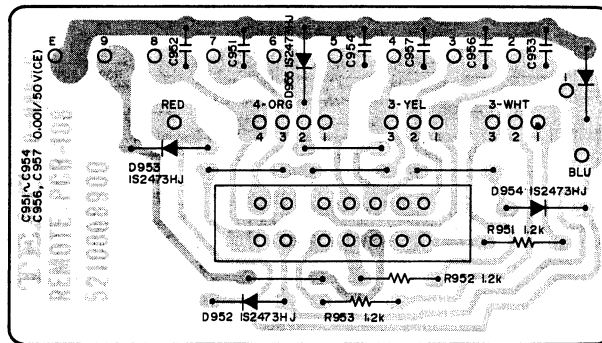

JOINT PCB ASSY

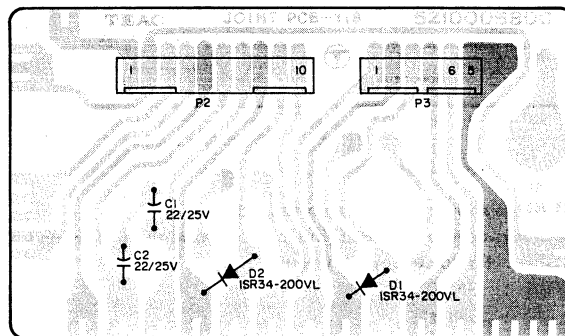

REC/PLAY AMPL PCB ASSY

REF. NO.	PARTS NO.	DESCRIPTION
	5200009100	PCB Assy [All except E]
	5200009110	PCB Assy [E]
	5210031100	PCB
	IC's	
U101	5147062000	LA3161
U102, U202	5147077000	LM1011N
U103	5220405000	μPC4557C
U104, U204	5147077000	LM1011N
U105, U205	5292802500	F350 Lowpass Filter
	TRANSISTORS	
Q101, Q201	5231750000	2SD1012G
Q102, Q202	5231757000	2SD1012G
Q103, Q203	5145119000	2SC1844F
Q104, Q204	5042486000	2SC536G
Q105, Q205	5042486000	2SC536G
Q106, Q206	5231757000	2SD1012G
Q107, Q207	5042486000	2SC536G
Q108, Q208	5140860000	2SC1636-2
	DIDOES	
D101, D201	5143118000	IS2473HJ
D106	5143118000	IS2473HJ
	CARBON RESISTORS	
All resistors are rated ±5% tolerance and ¼watt		
R101, R201	5183126000	68kΩ
R102, R202	5183070000	330Ω
R103, R203	5183046000	33Ω
R104, R204	5183132000	120kΩ
R106, R206	5183094000	3.3kΩ
R107, R207	5184090000	2.2kΩ
R108, R208	5183094000	3.3kΩ
R109, R209	5183130000	100kΩ
R110	5183086000	1.5kΩ
R111, R211	5183078000	680Ω
R112, R212	5183076000	560Ω
R113, R213	5183118000	33kΩ
R114, R214	5183118000	33kΩ
R115, R214	5183064000	180Ω
R116, R216	5183094000	3.3kΩ
R117, R217	5183122000	47kΩ
R118, R218	5183148000	560kΩ
R119, R219	5183140000	270kΩ
R120, R220	5183140000	270kΩ
R121, R221	5183082000	1kΩ
R122, R222	5183098000	4.7kΩ
R123, R223	5183137000	200kΩ
R124, R224	5183137000	200kΩ
R125, R225	5183090000	2.2kΩ
R126, R226	5183090000	2.2kΩ
R127, R227	5183042000	22Ω
R128, R228	5183106000	10kΩ
R129	Δ 5184249000	100Ω Non Flammable
R130, R230	5183106000	10kΩ
R131, R231	5183130000	100kΩ
R132, R232	5183114000	22kΩ
R133, R233	5183146000	470kΩ
R134, R234	5183070000	330Ω
R135, R235	5183050000	47Ω
R136, R236	5183108000	12kΩ

REF. NO.	PARTS NO.	DESCRIPTION
R137, R237	5183130000	100kΩ
R138	5183082000	1kΩ
R139, R239	5183034000	10Ω
R140, R240	5183122000	47kΩ
R141, R241	5183134000	150kΩ
R142, R242	5183130000	100kΩ
R143, R243	4183118000	33kΩ
R144, R244	5183118000	33kΩ
R145, R245	5183064000	180Ω
R146, R246	5183094000	3.3kΩ
R147, R247	5183122000	47kΩ
R148, R248	5183148000	560kΩ
R149, R249	5183140000	270kΩ
R150, R250	5183140000	270kΩ
R151, R251	5183078000	680kΩ
R152, R252	5183126000	68kΩ
R153, R253	5183118000	33kΩ
R154, R254	5183124000	56kΩ
R155, R255	5183146000	470kΩ
R156, R256	5183084000	1.2kΩ
R157, R257	5183106000	10kΩ
R158, R258	5183098000	4.7kΩ
R159, R259	5183106000	10kΩ
R160, R260	5183112000	18kΩ
R161, R261	5183110000	15kΩ
R162, R262	5183098000	4.7kΩ
R163, R263	5183124000	56kΩ
R164, R264	5183140000	270kΩ
R165, R265	5183086000	1.5kΩ
R166, R266	5183046000	33Ω
R167, R267	5183100000	5.6kΩ
R168, R268	5183062000	150Ω
R169, R269	5183106000	10kΩ
R170, R270	5183050000	47Ω
R171, R271	5183094000	3.3kΩ
R172, R272	5183122000	47kΩ
R173	5183076000	560Ω
R174	5183082000	1kΩ
R176, R276	5183098000	4.7kΩ
R177, R277	5183082000	1kΩ
R179	5183130000	100kΩ
R180, R280	5183114000	22kΩ
R181, R281	5183062000	150Ω
R182, R282	5183142000	330kΩ
R183, R283	5183096000	3.9kΩ
R184, R284	5183114000	22kΩ
R185, R285	5183046000	470kΩ
R186, R286	5183110000	15kΩ
R187	Δ 5184249000	100Ω Non flammable
R188, R288	5183310000	15kΩ
	CAPACITORS	
C101, C201	5172316000	Ceramic 220pF 50V 10%
C102, C202	5173571800	Elec. 10μF 16V
C103, C203	5173052800	Elec. 220μF 6.3V
C104, C204	5172312000	Ceramic 110pF 50V 10%
C106, C206	5170435000	Mylar 0.027μF 100V 5%
C107, C207	5173005800	Elec. 4.7μF 35V
C108, C208	5170409000	Mylar 0.0022μF 100V 5%
C109, C209	5173043100	Mylar 0.018μF 100V
C110	5173053800	Elec. 220μF 16V
C111, C211	5173053800	Elec. 220μF 16V
C112, C212	5173556800	Elec. 1μF 50V

[U]: U.S.A.
 [C]: CANADA [E]: EUROPE
 [GE]: GENERAL EXPORT [UK]: U.K.
 [A]: AUSTRALIA [L]: LIMITED AREA

REF. NO.	PARTS NO.	DESCRIPTION
C113, C213	5172320000	Ceramic. 470pF 50V 10%
C114, C214	5172996800	Elec. 2.2μF 50V
C115, C215	5172324000	Ceramic. 0.001μF 50V 10%
C116, C216	5172324000	Ceramic. 0.001μF 50V 10%
C117, C217	5170419000	Mylar 0.0056μF 100V 5%
C118, C218	5170435000	Mylar 0.027μF 100V 5%
C119, C219	5170417000	Mylar 0.0047μF 100V 5%
C120, C220	5173010800	Elec. 10μF 16V
C121, C221	5173053800	Elec. 220μF 10V
C122, C222	5173010800	Elec. 10μF 16V
C123, C223	5170441000	Mylar 0.047μF 100V 5%
C124, C224	5173010800	Elec. 10μF 16V
C125, C225	5170519000	Mylar 0.1μF 100V 10%
C126, C226	5173553800	Elec. 0.33μF 50V
C127, C227	5170409000	Mylar 0.0022μF 100V 5%
C128, C228	5172992800	Elec. 1μF 50V
C129, C229	5173045800	Elec. 100μF 16V
C130	5173046800	Elec. 100μF 25V
C131, C231	5173571800	Elec. 10μF 16V
C132, C232	5172316000	Ceramic. 220pF 50V 10%
C133, C233	5173044800	Elec. 100μF 10V
C134, C234	5173005800	Elec. 4.7μF 35V
C135	5173046800	Elec. 100μF 25V
C136, C236	5173556800	Elec. 1μF 50V
C137, C237	5172324000	Ceramic. 0.001μF 50V 10%
C138, C238	5173010800	Elec. 10μF 16V
C139, C239	5172324000	Ceramic 0.001μF 50V 10%
C140, C240	5172324000	Ceramic 0.001μF 50V 10%
C141, C241	5172996800	Elec. 2.2μF 50V
C142, C242	5170419000	Mylar 0.0056μF 100V 5%
C143, C243	5170435000	Mylar 0.027μF 100V 5%
C144, C244	5170417000	Mylar 0.0047μF 100V 5%
C145, C245	5173010800	Elec. 10μF 16V
C146, C246	5173053800	Elec. 220μF 10V
C147, C247	5173010800	Elec. 10μF 16V
C148, C248	5170441000	Mylar 0.047μF 100V 5%
C149, C249	5173010800	Elec. 10μF 16V
C150, C250	5170519000	Mylar 0.1μF 100V 10%
C151, C251	5173553800	Elec. 0.33μF 50V
C152, C252	5173054800	Elec. 220μF 16V
C153, C253	5173010800	Elec. 10μF 16V
C154, C254	5173010800	Elec. 10μF 16V
C155, C255	5173010800	Elec. 10μF 16V
C156, C256	5173564800	Elec. 4.7μF 25V
C157, C257	5170429000	Mylar 0.015μF 100V 5%
C158, C258	5170425000	Mylar 0.01μF 100V 5%
C159, C259	5170431000	Mylar 0.018μF 100V 5%
C160, C260	5170425000	Mylar 0.01μF 100V 5%
C161, C261	5170445000	Mylar 0.068μF 100V 5%
C162	5172992800	Elec. 1μF 50V
C163, C263	5054704000	Trimmer 100pF
C164	5173037800	Elec. 47μF 25V
C165, C265	5173731000	Polypro 820pF 100V 5%
C170, C270	5172992800	Elec. 1μF 50V
C171, C271	5173550800	Elec. 0.1μF 50V
C172, C172	5173019800	Elec. 22μF 25V
C173	5173046800	Elec. 100μF 25V
C174, C274	5172316000	Ceramic. 220pF 50V 10%
C175	5170425000	Mylar 0.01μF 100V 5%
VARIABLE RESISTORS		
R11, R21	528004002	Semi-fixed 50kΩ(B)
R12, R22	5280002802	Semi-fixed 1kΩ(B)

REF. NO.	PARTS NO.	DESCRIPTION
R13, R23	5280004002	Semi-fixed 50kΩ(B)
R14, R24	5280004002	Semi-fixed 50kΩ(B)
R15, R25	5282405602	20kΩ(A) x2
COILS		
L101, L201	5160107000	Choke 1.2mH
L102, L202	5160107000	Choke 1.2mH
L103, L203	5286000400	Choke 8mH
L104, L204	5086000500	Choke 3.4mH
L105	5160151000	Choke 1.2mH
L106, L206	5286000600	Trap 3mH
MISCELLANEOUS		
U107	5292200200	OSC Unit
S101	5131030000	Switch, Slide; 6P2T
S102	5300511000	Switch, Lever; 2P3T
S103	5300511300	Switch, Lever; 4P3T
S104	5300511400	Switch, Lever; 6P3T
S105	5300510800	Swich, Lever; 2P2T
S106, S107	5300018200	Switch, Push; DPDT (2-gang)
RT11, RT21	5143128000	Thermistor, S5C-34
RT12, RT22	5143128000	Thermistor, S5C-34
RT13, RT23	5143127000	Thermistor, S5C-14
	5126037000	Terminal Assy, IN/OUT [E]
	5126038000	Terminal Assy, IN/OUTPUT [All except E]
	5124063000	Jack, 3-gang
	5122130000	Connector Plug, 6P
	5122130000	Connector Plug, 6P
	5544750000	Pin, T.P. (6 used)

CONTROL PCB ASSY

REF. NO.	PARTS NO.	DESCRIPTION
	5200008700	PCB Assy
	5210008700	PCB
IC		
U501	5220802700	μPD553C
TRANSISTORS		
Q501 ~ Q503	5231755100	2SD880Y
Q511 ~ Q518	5145151000	2SC1815GR
Q519, Q520	5145082000	2SC2060Q
Q521	5145151000	2SC1815GR
Q522, Q523	5145082000	2SC2060Q
Q524, Q525	5145084000	2SA934Q
Q526	5231755100	2SD880Y
Q527 ~ Q531	5145151000	2SC1815GR
Q532	5145150000	2SA1015GR
Q533 ~ Q535	5145151000	2SC1815GR
Q536 ~ Q538	5145150000	2SA1015GR
Q539 ~ Q550	5145151000	2SC1815GR
Q551	5145084000	2SA934Q
DIDOES		
D501 ~ D504	5143116000	1SR34-200VL
D505	5224517500	Zener RD22EB3
D506 ~ D509	5143116000	1SR34-200VL
D510	5224518100	Zener RD11EB2
D511 ~ D520	5042517000	1S2473VE
D523 ~ D526	5042517000	1S2473VE

[U]: U.S.A. [E]: EUROPE
 [C]: CANADA [GE]: GENERAL EXPORT [UK]: U.K.
 [A]: AUSTRALIA [L]: LIMITED AREA

REF. NO.	PARTS NO.	DESCRIPTION
D527	5143118000	1S2473HJ
D528 ~ D530	5042517000	1S2473VE
D531	5042554000	Zener, RD6.2EB 3%
D532 ~ D534	5042517000	1S2473VE
D535, D536	5224518000	Zener, RD8.2EB3
D537	5042554000	Zener, RD6.2EB 3%
D538	5143118000	1S2473HJ
D539, D540	5042517000	1S2473VE
D541	5224531501	Zener, RD4.7EB1
D542	5224531601	Zener, RD9.1EB2
RESISTORS		
All resistors are rated $\pm 5\%$ tolerance, $\frac{1}{4}$ watt. and of carbon type unless otherwise noted.		
R501	5183086000	1.5k Ω
R502	5183088000	1.8k Ω
R503, R504	5183082000	1k Ω
R505, R506 Δ	5184429000	120 Ω 5W 10% Cement
R511 ~ R517	5183130000	100k Ω
R518 ~ R520	5183094000	3.3k Ω
R521 ~ R523	5183120000	39k Ω
R524 ~ R526	5183088000	1.8k Ω
R527	5183130000	100k Ω
R528	5183094000	3.3k Ω
R529 ~ R538	5183106000	10k Ω
R540	5183130000	100k Ω
R541	5183094000	3.3k Ω
R542	5183130000	100k Ω
R543, R544	5183094000	3.3k Ω
R545, R546	5183130000	100k Ω
R547	5183094000	3.3k Ω
R548	5183130000	100k Ω
R549	5183094000	3.3k Ω
R550	5183130000	100k Ω
R551	5183094000	3.3k Ω
R552	5183130000	100k Ω
R553, R554	5183086000	1.5k Ω
R555, R556	5183142000	330k Ω
R559, R560	5183106000	10k Ω
R561, R562	5183094000	3.3k Ω
R567	5183130000	100k Ω
R568	5183114000	22k Ω
R569	5183070000	330 Ω
R570	5183130000	100k Ω
R571	5183072000	390 Ω
R572	5183140000	270k Ω
R573	5183070000	330 Ω
R574	5183100000	5.6k Ω
R575, R576	5183114000	22k Ω
R577	5183112000	18k Ω
R578	5183120000	39k Ω
R579	5183124000	56k Ω
R580	5183130000	100k Ω
R581	5183106000	10k Ω
R582	5183084000	1.2k Ω
R583	5183130000	100k Ω
R584	5183116000	27k Ω
R585	5183106000	10k Ω
R586	5183130000	100k Ω
R587 ~ R589	5183102000	6.8k Ω
R590	5183094000	3.3k Ω
R591	5183120000	39k Ω
R592	5183094000	3.3k Ω
R593	5183120000	39k Ω

REF. NO.	PARTS NO.	DESCRIPTION
R594	5183094000	3.3k Ω
R595	5183120000	39k Ω
R596 ~ R602	5183106000	10k Ω
R603 ~ R609	5183074000	470 Ω
R610	5183118000	33k Ω
R611	5183106000	10k Ω
R612	5183130000	100k Ω
R613	5183086000	1.5k Ω
R614	5183094000	3.3k Ω
R615	5183074000	470 Ω
R616	5183100000	5.6k Ω
R617	5240170600	10k Ω
R618, R619	5183082000	1k Ω
CAPACITORS		
C501	5172973800	Elec. 1000 μ F 50V
C502, C503	5173055800	Elec. 220 μ F 25V
C504	5172978800	Elec. 2200 μ F 25V
C505	5173045800	Elec. 100 μ F 16V
C506	5173054800	Elec. 220 μ F 16V
C507	5173036800	Elec. 47 μ F 16V
C508	5173054800	Elec. 220 μ F 16V
C509, C510	5173073800	Elec. 470 μ F 25V
C511, C512	5170425800	Mylar 0.01 μ F 100V 5%
C513	5173753000	Polypro. 0.003 μ F 100V 5%
C514	5172304000	Ceramic 22pF 50V 10%
C515	5173010800	Elec. 10 μ F 16V
C516	5172992800	Elec. 1 μ F 50V
C517	5173560800	Elec. 2.2 μ F 50V
C518	5173036800	Elec. 47 μ F 16V
C519, C520	5172792000	Polyst. 33pF 50V 5%
C521	5173395000	Ceramic 0.047 μ F 50V 10%
C522	5173010800	Elec. 10 μ F 16V
C523 ~ C525	5170409800	Mylar 0.0022 μ F 100V 5%
C526	5172324000	Ceramic 0.01 μ F 50V 10%
MISCELLANEOUS		
	5033291000	Plate, Insul. (4 used)
	5033295000	Tube, Insul. (4 used)
	5800042401	Bracket, PCB; A
	5800042501	Bracket, PCB; B

TIMER PCB ASSY

REF. NO.	PARTS NO.	DESCRIPTION
	5200008800	PCB Assy
	5210008800	PCB
Q970	5145151000	Transistor, 2SC1815GR
D550, D551	5042517000	Diode, 1S2473VE
C550	5173571800	Capacitor, Elec. 10 μ F 16V
R650, R651	5240170600	Resistor, Carbon 10k Ω $\frac{1}{4}$ W 5%
R652	5240173000	Resistor, Carbon 100k Ω $\frac{1}{4}$ W 5%
	5133019000	Switch, Rotary; DP3T

[U]: U.S.A.
 [C]: CANADA [E]: EUROPE
 [GE]: GENERAL EXPORT [UK]: U.K.
 [A]: AUSTRALIA [L]: LIMITED AREA

CPS PCB-102 ASSY

REF. NO.	PARTS NO.	DESCRIPTION
	5200030900	PCB Assy
	5210030900	PCB
TRANSISTORS		
Q701	5145150000	2SA1015GR
Q702, Q703	5145151000	2SC1815GR
Q704, Q705	5145034000	2SC900UA
Q706	5145150000	2SA1015GR
DIODES		
D701 ~ D703	5042517000	1S2473VE
CARBON RESISTORS		
All resistors are rated $\pm 5\%$ tolerance and $\frac{1}{4}$ watt.		
R701	5240162400	3.9 Ω
R702	5240165400	68 Ω
R703	5240167600	560 Ω
R704	5240169200	2.7k Ω
R705	5240170000	5.6k Ω
R706	Δ 5240167800	680 Ω
R707	5240171800	33k Ω
R708	5240167400	470 Ω
R709	5240172200	47k Ω
R710	5240168200	1k Ω
R711	5240173000	100k Ω
R712	5240167000	330 Ω
R713	5240170000	5.6k Ω
R714	5240167000	330 Ω
R715	5240167400	470 Ω
R716	5240171000	15k Ω
R717	5240172200	47k Ω
R718	5240173800	220k Ω
R719	5240168200	1k Ω
R720	5240170600	10k Ω
R721	5240168200	1k Ω
CAPACITORS		
C701	5170433800	Mylar 0.022 μ F 100V 5%
C702	5173005800	Elec. 4.7 μ F 35V
C703	5172304000	Ceramic 22pF 50V 10%
C704	5170401800	Mylar 0.001 μ F 100V 5%
C705	5173005800	Elec. 4.7 μ F 35V
C706	5173010800	Elec. 10 μ F 16V

REMOTE CONTROL PCB ASSY

REF. NO.	PARTS NO.	DESCRIPTION
	5200008900	PCB Assy
	5210008900	PCB
D951 ~ D955	5143118000	Diode, 1S2473HJ
R951 ~ R953	5183084000	Resistor, Carbon 1.2k Ω $\frac{1}{4}$ W 5%
C951 ~ C957	5172324000	Capacitor, Ceramic 0.001 μ F 50V 10%
	5122336000	Connector Socket, 12P
	5534866000	Escutcheon, Connector
	5555566000	Bracket, Connector

JOINT PCB ASSY

REF. NO.	PARTS NO.	DESCRIPTION
	5200005800	PCB Assy
	5210005800	PCB
D1, D2	5143116000	Diode, 1SR34-200VL
C1, C2	5173019800	Capacitor, Elec. 22 μ F 25V
	5122149000	Connector Plug, 6P
	5122153000	Connector Plug, 10P

VOLUME PCB ASSY (PC Board Omitted.)

REF. NO.	PARTS NO.	DESCRIPTION
	5200009200	PCB Assy
	5210009200	PCB
R15, R25	5282705700	Var. Res. 100k Ω (A) x 2

FUSE PCB ASSY [E, UK] (PC Board Omitted.)

REF. NO.	PARTS NO.	DESCRIPTION
	5200006000	PCB Assy
	5210006000	PCB
F1	5142087000	Holder, Fuse (6 used)
F2, F3	Δ 5142183000	Fuse, T315mA 250V
	Δ 5041140000	Fuse, T1A 250V

VOLTAGE SELECTOR PCB ASSY [GE, L] (PC Board omitted.)

REF. NO.	PARTS NO.	DESCRIPTION
	5168548100	PCB Assy
	5167548101	PCB
	5555062000	Bracket A, Voltage Selector

COUNTER PCB ASSY (PC Board Omitted.)

REF. NO.	PARTS NO.	DESCRIPTION
	5200009300	PCB Assy
	5210009300	PCB
S5, S6	5225005300	LED SL1405
	6051083000	Switch, Tact

[U]: U.S.A.
 [C]: CANADA
 [GE]: GENERAL EXPORT
 [A]: AUSTRALIA
 [E]: EUROPE
 [UK]: U.K.
 [L]: LIMITED AREA

TEAC TECHNICAL INFORMATION

A-770, Auto Stop

NO. 8213

DATE 7 July 1982

To improve the reliability of A-770 Cassette auto stop function, the circuits on PCB Assy Stop Sensor and Joint PCB Assy have been changed on the products serial numbered 21531 and after. In Fig 1 and Fig 2 are the diagrams of these former and new circuits. The former circuit can be changed into new circuit by making several modifications on the two PCB Assys as shown in Fig 3 and Fig 4.

Hereunder is the procedure to make this modification.

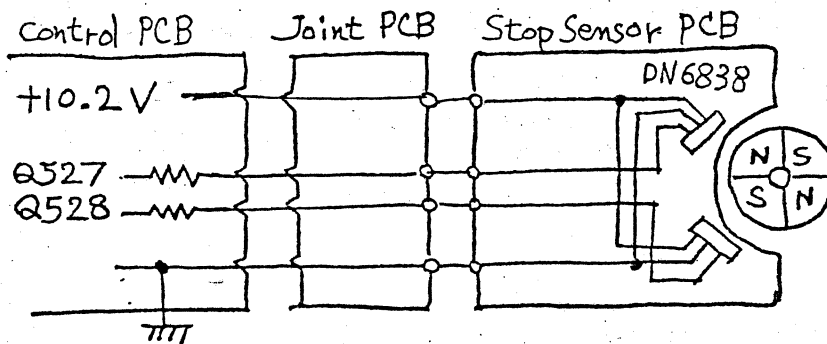

Fig 1

Former
Circuit

Fig 2

New
Circuit

- 1.0 On Stop Sensor PCB
 - 1.1 Cut jumper wire at X1 point, and remove them from PCB.
 - 1.2 Cut foil pattern at X2 point.
 - 1.3 Connect points A and B by jumper wire.
 - 1.4 Connect points C and D by insulated jumper wire.
 - 1.5 Interchange the connections of Blue and brown wires at points E and F.
 - 1.6 Remove old Hole IC DN6838 (Parts No 52287001) from PCB, and mount new Hole IC TL170C (Parts No 52287001). On mounting this IC, care should be taken to keep the 18° angle as shown in Fig 4, as well as to face the flat side of IC against magnet rotor.
- 2.0 On Joint PCB
 - 2.1 Cut foil pattern at X3 point.
 - 2.2 Connect three resistors and one zener diode RD5.6EB on the foil side of PCB as shown in Fig 3.

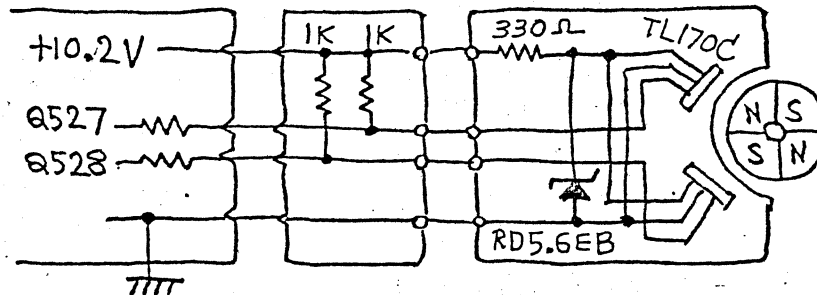
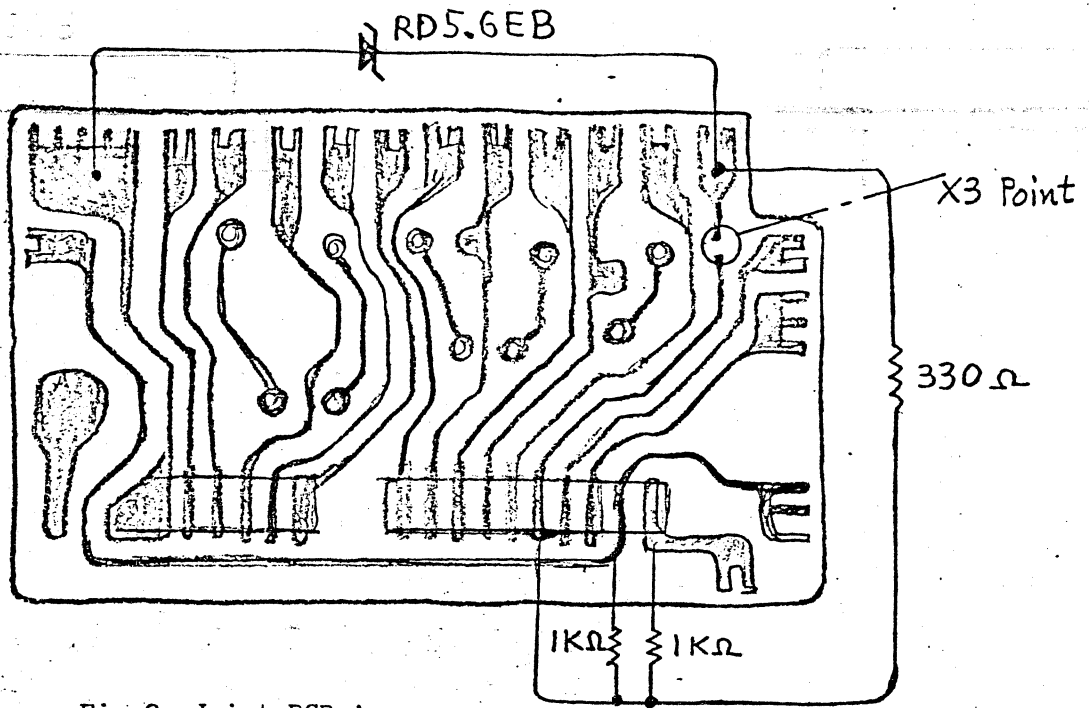

Fig 3 Joint PCB Assy

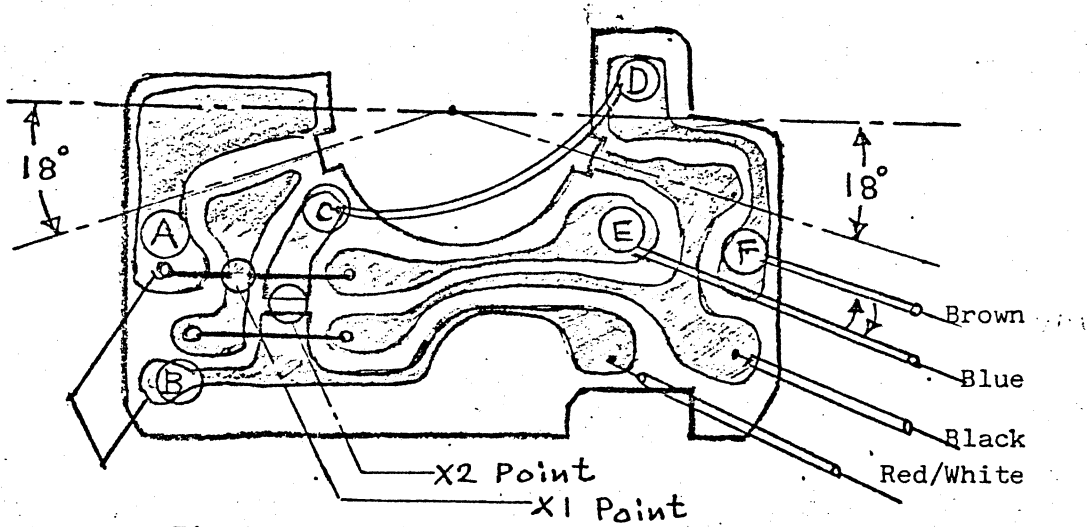

Fig 4

Stop Sensor PCB Assy

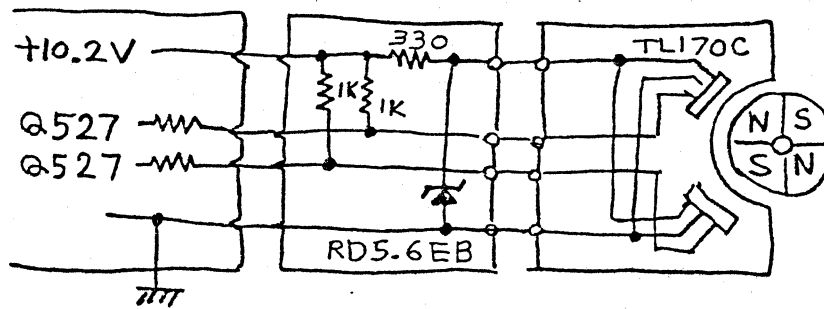
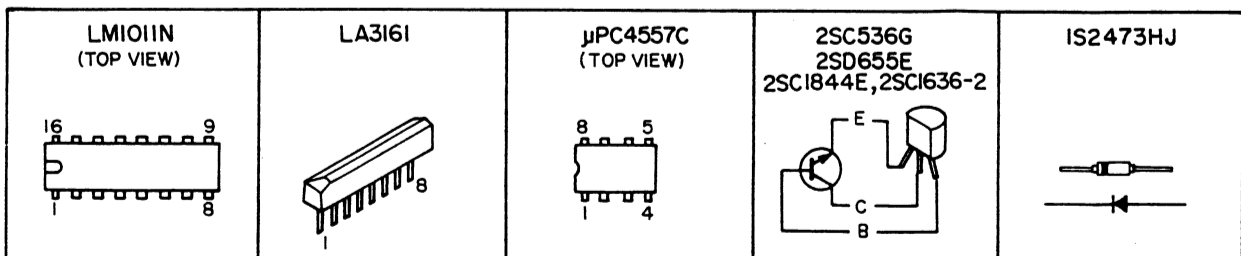
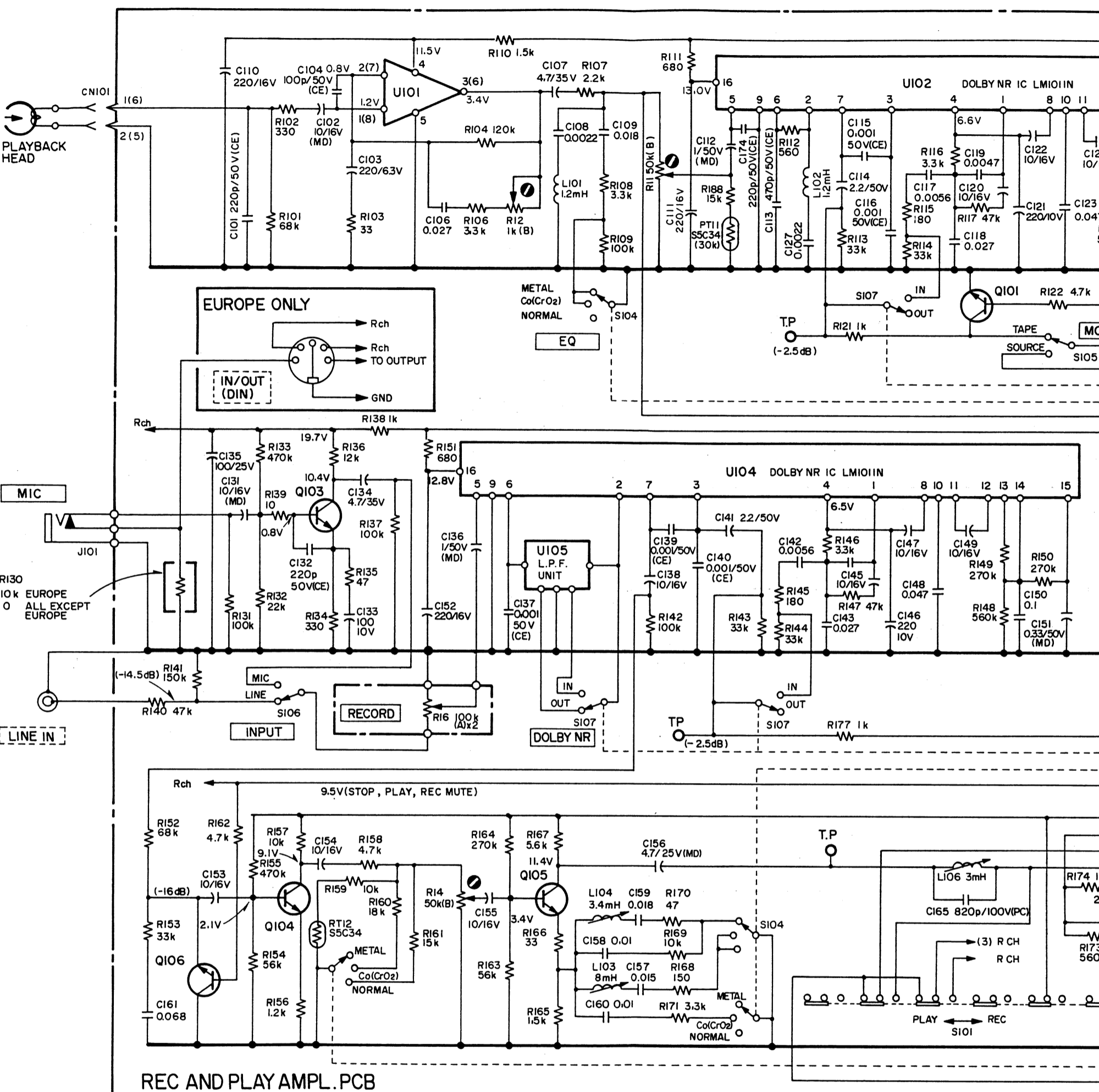
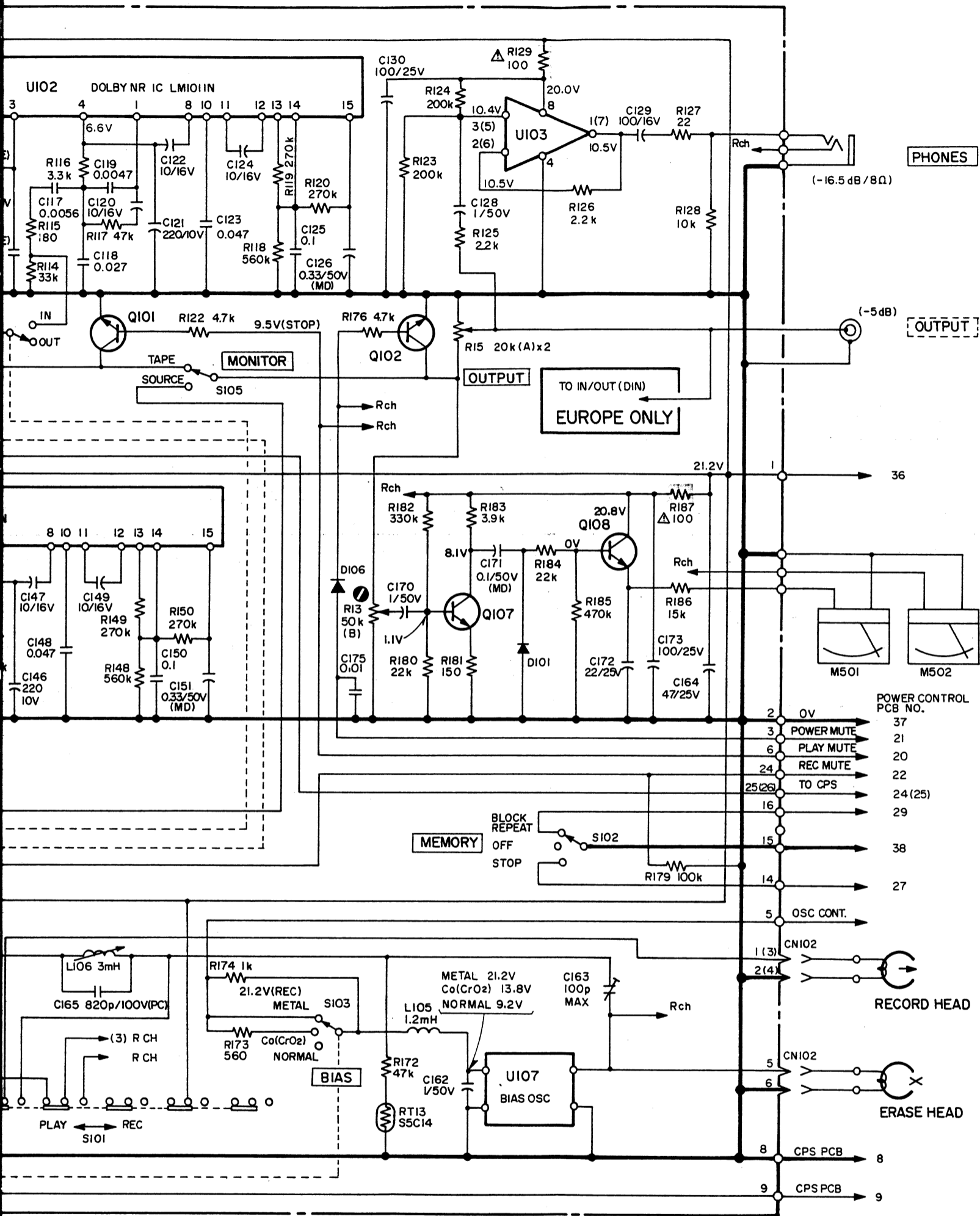

Fig 5 Circuit after Modification

1 2 3 4 5 6



- UI01 LA3161
- UI02, UI04 LM1011M
- UI03 μPC4557C
- Q101 2SD655E or 2SD1012G
- Q102 2SD655E or 2SD1012G
- Q103 2SC1844F
- Q104, Q105 2SC536G
- Q106 2SD655E or 2SD1012G
- Q107 2SC536G
- Q108 2SC1636-2
- D101, D106 IS2473HJ



- LA3161
- LM1011M
- μPC4557C
- 2SD655E or 2SD1012G
- 2SD655E or 2SD1012G
- 2SC1844F
- 2SC536G
- 2SD655E or 2SD1012G
- 2SC536G
- 2SC1636-2
- IS2473HJ

- NOTES**
1. Schematic diagram shown for left channel except for some of the components.
 2. All resistors are 1/4 watt, ±5%, unless marked otherwise. Resistor values are in ohms (k = 1,000 ohms).
 3. All capacitor values are in microfarads (p = picofarads). All non-polarized capacitors are ±5% mylar unless otherwise specified.
 4. Parts marked with this sign are safety critical components. They must always be replaced with identical components - refer to the TEAC parts list and ensure exact replacement.
 5. Voltage and level values are for reference only. Indicated values are those existing when the peak level meter indicates 0 dB = 0.775V
 6. : front panel indication
 7. : rear panel indication
 8. +B power supply circuit

A-770
Stereo Cassette Deck

A
B
C
D
E
F
G
H

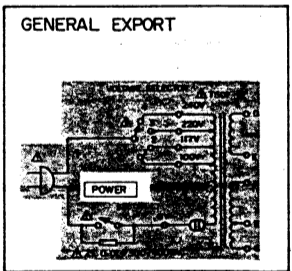
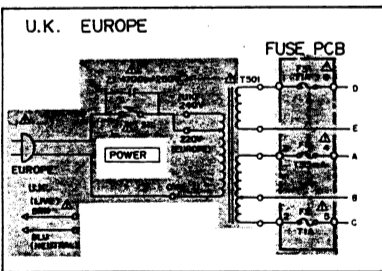
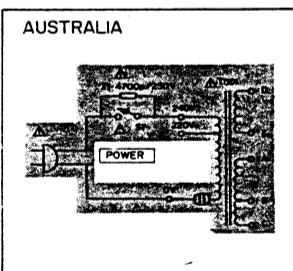
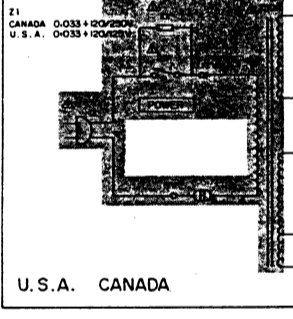
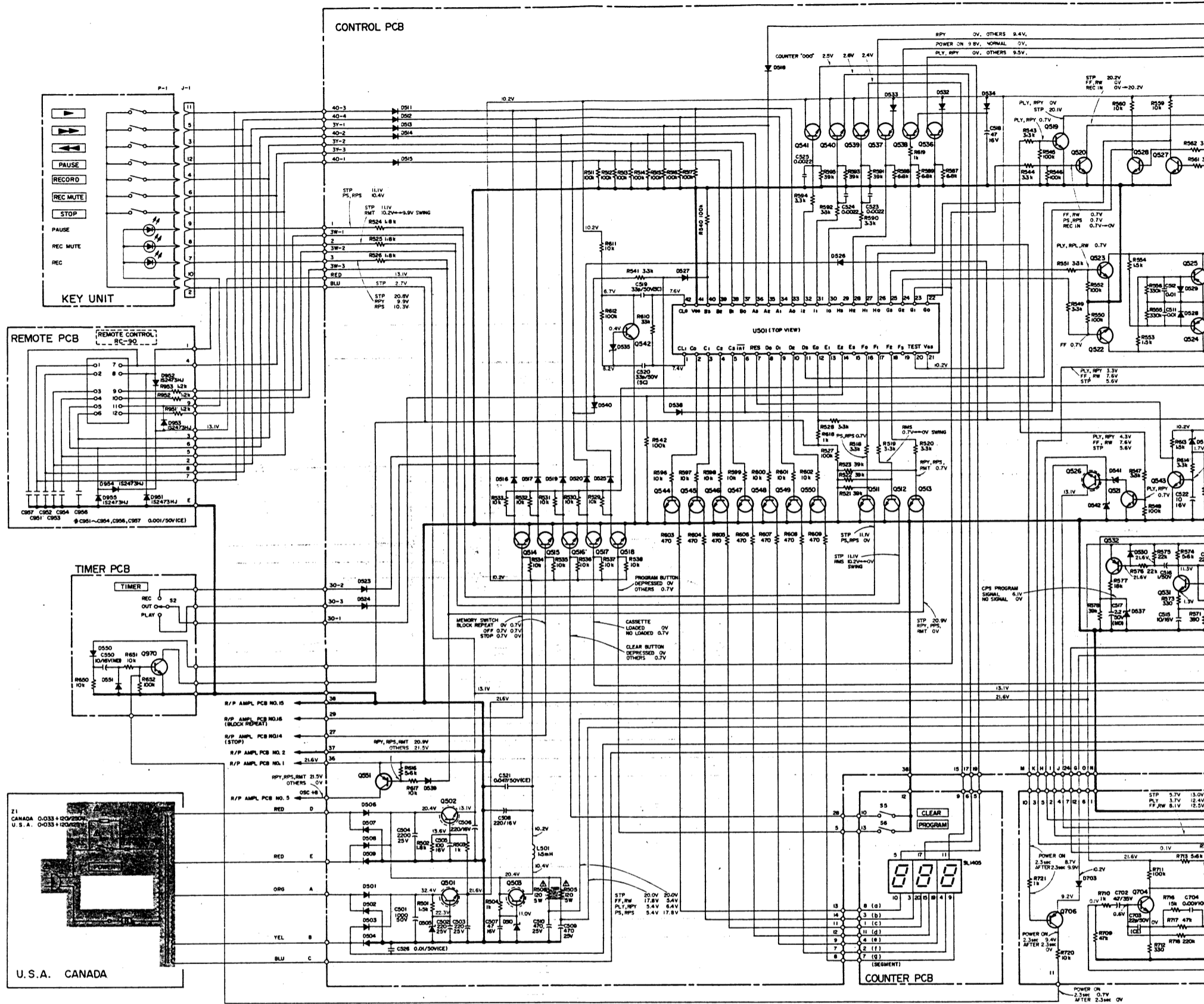

CONTROL PCB			TIMER PCB		
U501	μPD553C-082				
0501 ~ 0503	2SD880Y	0501 ~ 0504	1SR34 200VL	0970	2SC85GR
0504 ~ 0510	(NOT USED)	0505 ~ 0509	1SR34 200VL	0550, 0551	1S2473VE
0511 ~ 0518	2SC1815GR	0510	RD1 E82		
0519, 0520	2SC2060Q	0511 ~ 0520	1S2473VE		
0521	2SC1815GR	0521, 0522	(NOT USED)		
0522, 0523	2SC2060Q	0523 ~ 0526	1S2473VE		
0524, 0525	2SA934Q	0527	1S2473VE		
0526	2SD880Y	0528 ~ 0530	1S2473VE		
0527, 0528	2SC1815GR	0531	RD6.2EB		
0530, 0531	2SC1815GR	0532 ~ 0534	1S2473VE		
0532	2SA1015GR	0535, 0536	RD6.2EB		
0533 ~ 0535	2SC1815GR	0537	RD6.2EB		
0536 ~ 0538	2SA1015GR	0538	1S2473HJ		
0539 ~ 0550	2SC1815GR	0539, 0540	1S2473VE		
0551	2SA934Q	0541	RD4.7EB		
		0542	RD9.1EB		

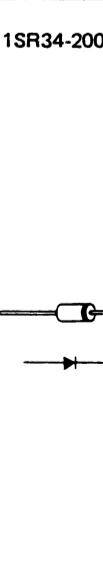
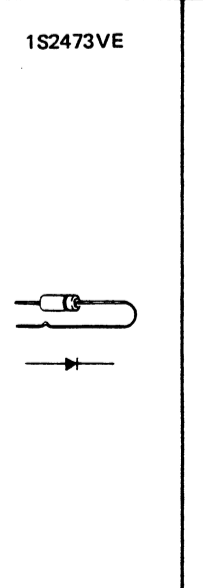
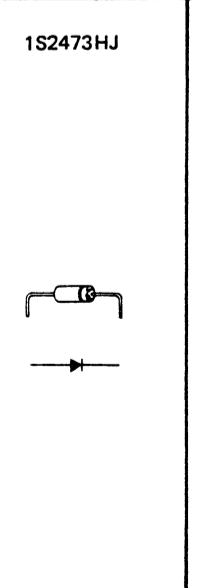
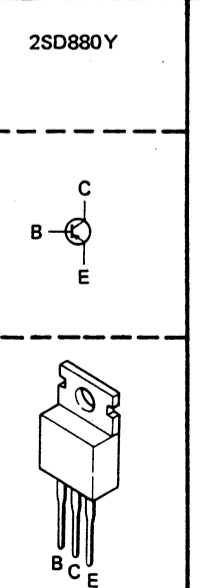
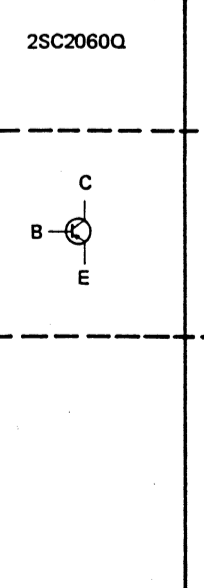
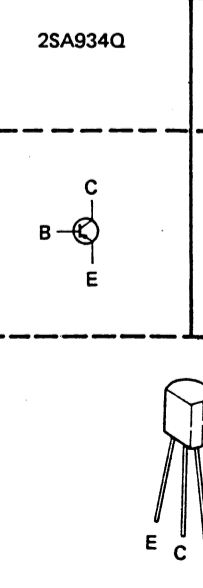
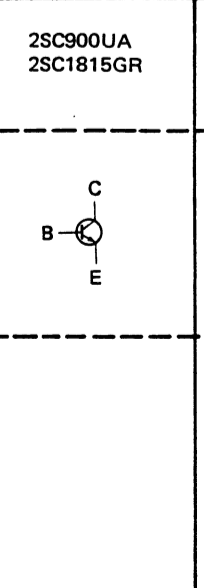
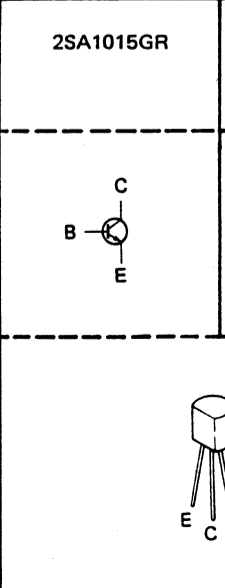
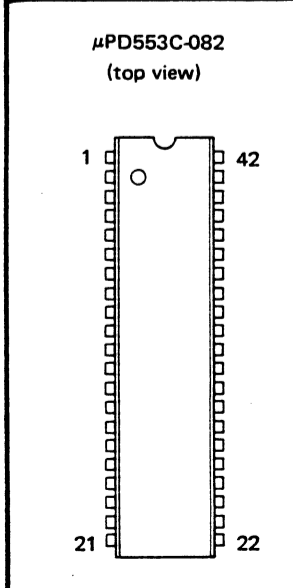

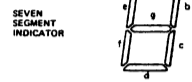
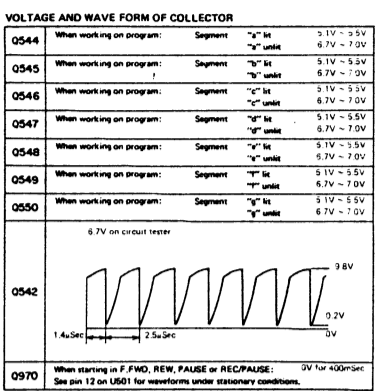
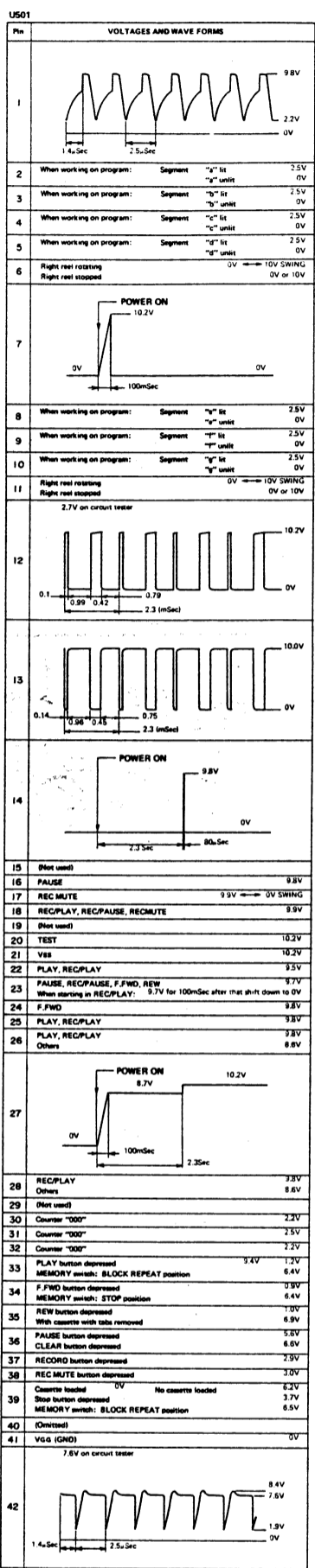
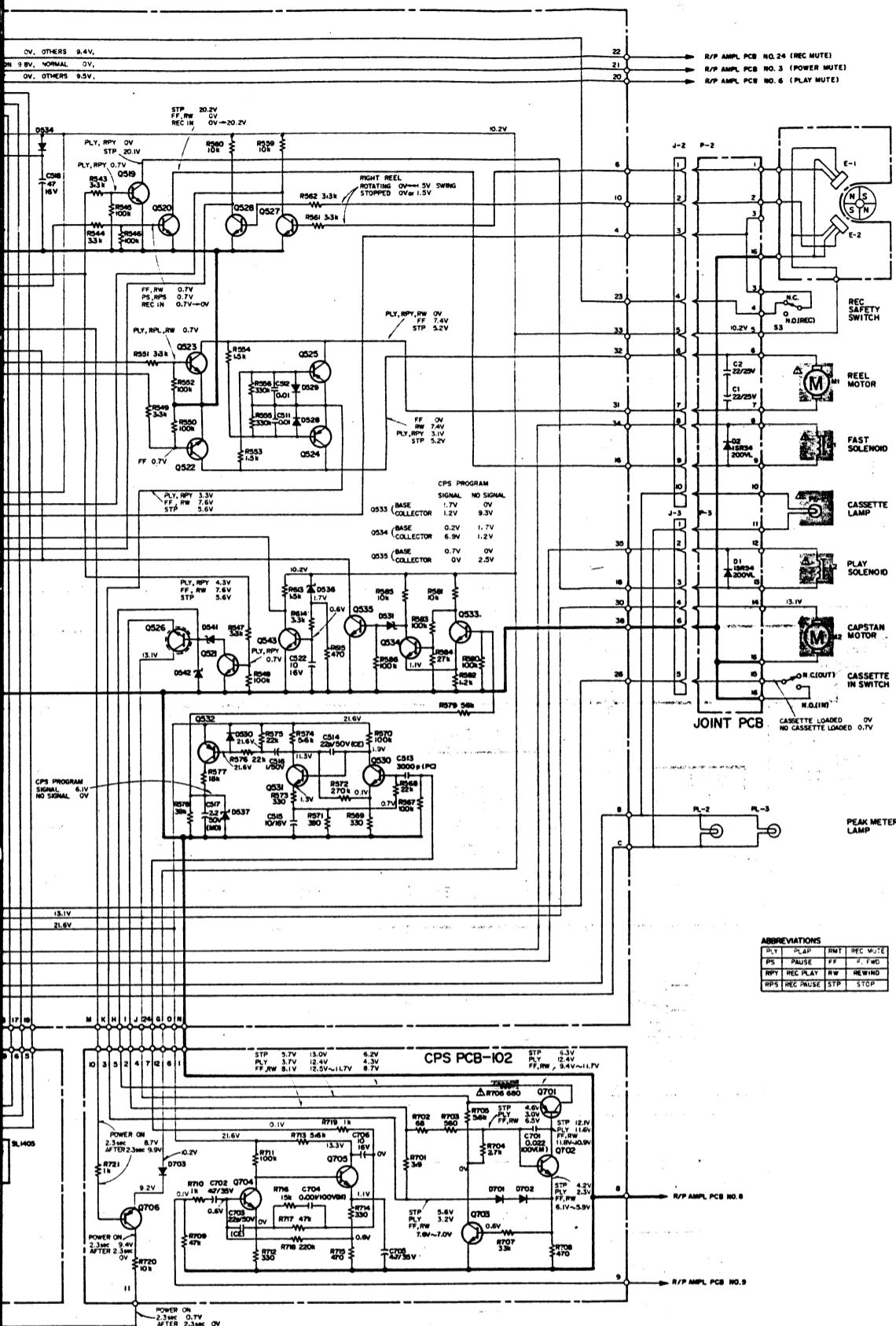

ABBREVIATIONS

PLY	SLAP	RMT	REC MUTE
PS	PAUSE	FF	F.FWD
RPT	REC PLAY	RW	REWIND
RPS	REC PAUSE	STP	STOP

NOTES

- All resistors are 1/4 watt, ±5%, unless marked otherwise. Resistor values are in ohms (k = 1,000 ohms).
- All capacitor values are in microfarads (µ = picofarads).
- Parts marked with this sign are safety critical components. They must always be replaced with identical components - refer to the TEAC parts list and ensure exact replacement.
- The input impedance to the oscilloscope for waveform monitoring is 10MΩ/13pF with its frequency range of 200MHz in bandwidth. In waveform monitoring with any oscilloscope of a lower input impedance, longer cycle times can be anticipated in its waveforms with possible variation in voltage.
- : front panel indication
- : rear panel indication
- +B : +B power supply circuit

