

TEAC

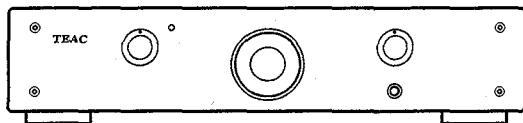

SERVICE MANUAL

A-BX10/PA-B10

Integrated Stereo Amplifier / Balanced MM/MC Preamplifier

NOTES

- PC boards shown are viewed from parts side.
- The parts with no reference number or no parts number in the exploded views are not supplied.
- As regards the resistors and capacitors, refer to the circuit diagrams contained in this manual.
- ⚠ Parts marked with this sign are safety critical components. They must be replaced with identical components - refer to the appropriate parts list and ensure exact replacement.
- Parts of [] mark can be used only with the version designated.
[C]: CANADA [E]: EUROPE [UK]: U. K.
A-BX10(N): Gold Version A-BX10(B): Black Version

1 SPECIFICATIONS

Continuous Power Output (RMS):

100W+100W (20 – 20,000 Hz, 8 ohms)
160W+160W (20 – 20,000 Hz, 4 ohms)

Dynamic Power Output (EIA):

120W+120W (8 ohms)
220W+220W (4 ohms)

Total Harmonic Distortion:

(Continuous rated output power)
0.04% (20 – 20,000 Hz, – 1 dB, 8 ohms)
0.06% (20 – 20,000 Hz, – 1 dB, 4 ohms)

Input Sensitivity/Impedance:

CD, TUNER, AUX, TAPE: 300 mV/20k ohms
BALANCED (XLR): 1 V/20k ohms

Output Level/Impedance:

TAPE 1, TAPE 2: 300 mV/100 ohms

Signal-to-Noise Ratio (IHF A):

CD, TUNER, AUX, TAPE: 106 dB

Frequency Response:

CD, TUNER, AUX, TAPE, BALANCED:
20 – 40,000 Hz, – 1 dB

Power Requirements/Power Consumption:

120 V AC, 60 Hz, 5 A
(U.S.A./Canada/General Export Model)
230 V AC, 50 Hz, 500 W
(Europe/UK/General Export Model)

Dimensions (W x H x D):

443 x 103 x 381mm

Weight (net): 11.8 kg

Standard Accessories:

AC cord x 1, Owner's Manual x 1

- Improvements may result in specification or feature changes without notice.

Installation procedure PA-B10

- Disconnect power line cord.
1. Using a hexagon-head tool, remove the top cover of **A-BX10**. Insert the four spacers into the holes in the main PCB.
 2. Remove the four jumpers on **P11**, one jumper **JP1** and the one jumper on **P10** (Pins 3 & 4) on the main PCB.
 3. Connect the long wires connector of **PA-B10** to **P11**, and the short wires connector to **P10** on the main PCB.
 4. Fix the **PA-B10** on the spacers using the four screws provided.
 5. Before fixing the top cover again, select the right position of **SW1** (MM or MC) and **SW2** (For MC cartridges, the impedance set to 22 Ω or 100 Ω) on **PA-B10**.
 6. Connect the turntable to the AUX terminals and GND terminal of **A-BX10**.

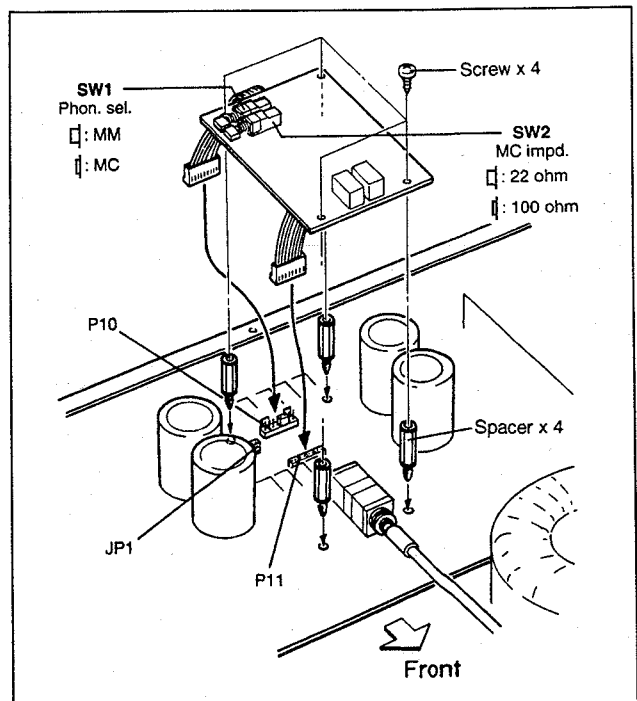

2 ADJUSTMENT

Bias Current Adjustment

Europe/UK Model:

1. 2x2 Jumpers are removed from **P200** and **P300**.
2. 4 x Bias current is measured as voltage across 0.22 ohms resistor between 1&2 and 3&4 on **P200** and **P300**.
3. Adjust bias current to 4 x 18mV by turning **R224**, **R229**, **R324** and **R329** slowly.
Clockwise turning increase bias current.
4. Then put on lid and wait 15 minutes, then take off lid and readjust to 4 x 20mV.
5. Place 2x2 jumpers on **P200** and **P300** again.

Canada Model:

1. 4 x Bias current is measured as current in **F200**, **F201**, **F300**, **F301** fuse holders (fuses must be removed).
2. Adjust bias current to 4 x 82mA by turning **R224**, **R229**, **R324** and **R329** slowly.
Clockwise turning increase bias current.
3. Then put on lid and wait 15 minutes, then take off lid and readjust to 4 x 91mA.
4. Remember to place fuses again after adjustments.

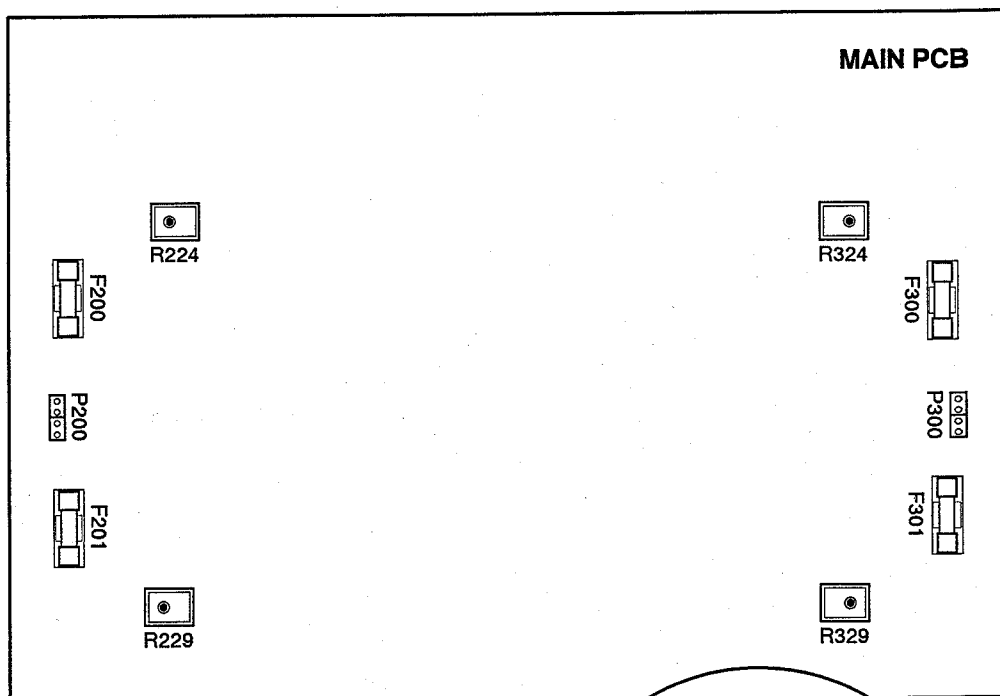

3 EXPLODED VIEWS AND PARTS LIST

EXPLODED VIEW-1

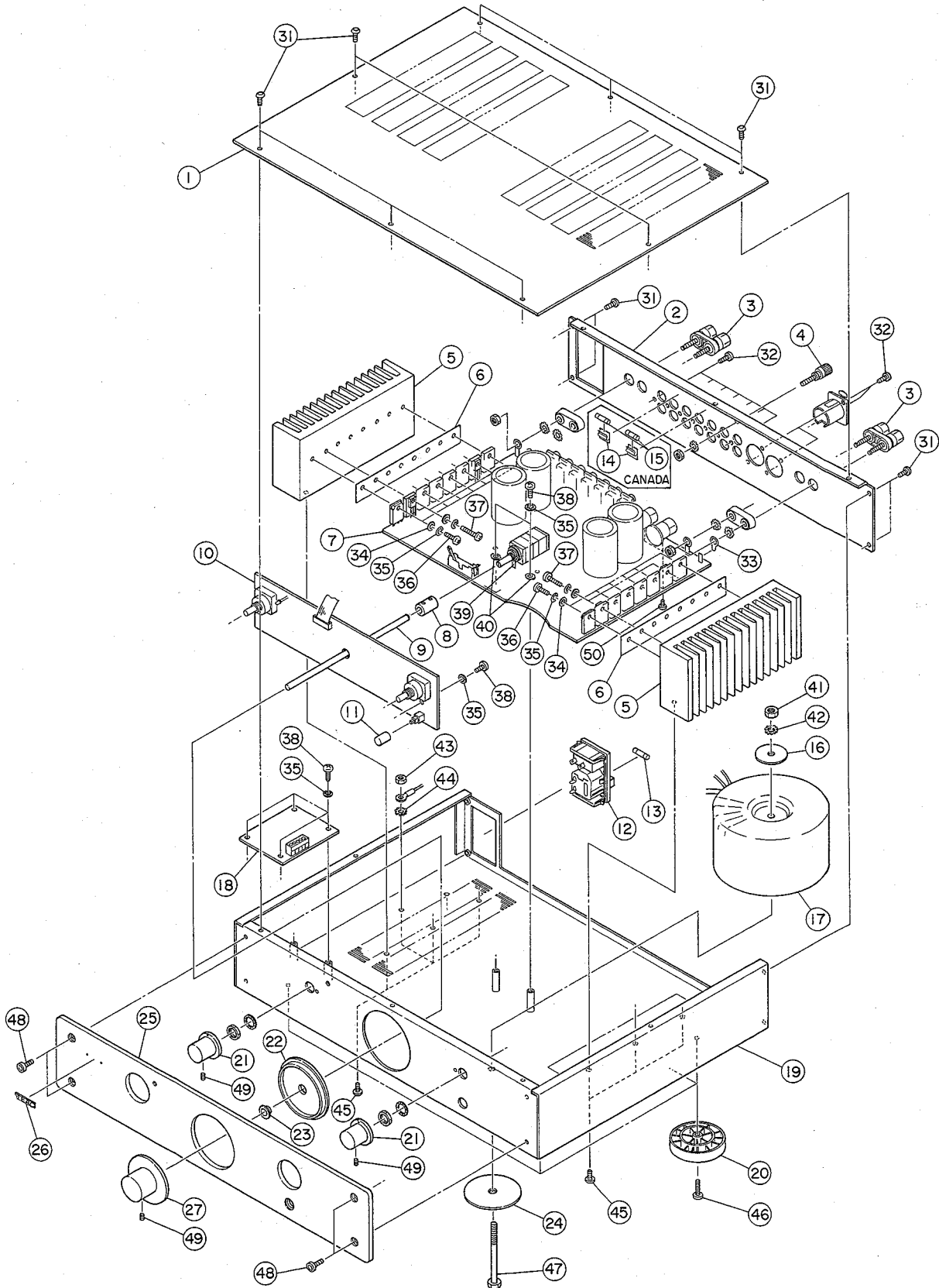

EXPLODED VIEW-1

REF. NO.	PARTS NO.	DESCRIPTION	REMARKS
1- 1	9A05214500	LID, BLK	A-BX10 (B)
	9A05287400	LID, GLD	A-BX10 (N)
1- 2	9A05214600	REAR PANEL, BLK	A-BX10 (B)
	9A05287500	REAR PANEL, GLD	A-BX10 (N)
1- 3	9A05213200	BINDING POST, K207Z GOLD	
1- 4	9A05213300	BINDING POST, K213 BLACK	
1- 5	9A05213000	HEAT SINK, SK85/75MM/SA	
1- 6	9A05213100	ISOLATION, SILICONE 146*24	
1- 7	9A05201000	MAIN PCB ASSY [C]	
	9A05201020	MAIN PCB ASSY [E, UK]	
1- 8	9A05215900	LINK, 06MM 12*20MM	
1- 9	9A05215200	VOLUME SHAFT, 6*173	
1-10	9A05210900	FRONT PANEL PCB ASSY	
1-11	9A05215100	KNOB, MONITOR BLK	A-BX10 (B)
	9A05287900	KNOB, MONITOR GLD	A-BX10 (N)
1-12	△ 9A05212900	INLET MODULE	
1-13	△ 9A05287200	FUSE, F6. 3AH/250V	
1-14	9A05211400	FUSE HOLDER, KKC3 [C]	
1-15	△ 9A05287100	FUSE, F4A 125V [C]	
1-16	9A05395800	WASHER, 30*1. 6MM	
1-17	△ 9A05213700	TRANSFORMER, 120V [C]	
	△ 9A05213800	TRANSFORMER, 230V [E, UK]	
1-18	9A05211000	MAIN CONNECTOR PCB ASSY	
1-19	9A05214400	CABINET, BASIS BLK	A-BX10 (B)
	9A05287300	CABINET, BASIS GLD	A-BX10 (N)
1-20	5801414900	FOOT ASSY	
1-21	9A05214800	KNOB, SELECTOR BLK	A-BX10 (B)
	9A05287700	KNOB, SELECTOR GLD	A-BX10 (N)
1-22	9A05215000	DECORATION RING, GLD	
1-23	9A05216200	BEARING, 9*14MM	
1-24	9A05215600	WASHER, M6 PLAIN	
1-25	9A05214700	FRONT PANEL, BLK	A-BX10 (B)
	9A05287600	FRONT PANEL, GLD	A-BX10 (N)
1-26	5801413200	NAME PLATE, TEAC	A-BX10 (B)
	5801533700	NAME PLATE, TEAC (GRY T)	A-BX10 (N)
1-27	9A05214900	KNOB, VOL. BLK	A-BX10 (B)
	9A05287800	KNOB, VOL. GLD	A-BX10 (N)
1-31	9A05214200	SCREW, ULS M3*6	
1-32	9A05215800	SCREW, SELFTAP 2. 9*8 BLK	
1-33	9A05212200	SOLDER TAG, M5	
1-34	9A05212000	WASHER, M3 PLAIN	
1-35	9A05211900	WASHER, M3 INT. SHAKE-PROOF	
1-36	9A05211700	SUPADRIV, M3*12	
1-37	9A05211800	SUPADRIV, M3*16	
1-38	9A05211600	SUPADRIV, M3*8	
1-39	9A05212300	SOLDER TAG, M10	
1-40	9A05212500	RING TERMINAL, M4	
1-41	9A05215400	NUT, M6	
1-42	9A05215500	WASHER, M6 VIB. PROOF	
1-43	9A05395900	NUT, M4	
1-44	9A05212100	WASHER, M4 SHAKE-PROOF	
1-45	9A05214300	SCREW, ULS M4*8	
1-46	9A05396000	SCREW, SELFTAPPING 3. 9*19	
1-47	9A05215300	SCREW, MACHINE M6*75	
1-48	9A05396100	SCREW, UNBRAKO M4*10 (BLK)	A-BX10 (B)
	9A05396200	SCREW, UNBRAKO M4*10 (GLD)	A-BX10 (N)
1-49	9A05214100	SCREW, MSF FLAT M3*6	
1-50	9A05215700	SCREW, SELFTAP 2. 9*4. 5	

4 PC BOARDS AND PARTS LIST

MAIN PCB ASSY

REF. NO.	PARTS NO.	DESCRIPTION
	9A05201000	MAIN PCB ASSY [C]
	9A05201020	MAIN PCB ASSY [E, UK]
C100-107	△ 9A05205600	C, ELYT 470UF 35V
C110-113	△ 9A05205700	C, ELYT 10MF 63V
C116, 117	△ 9A05205600	C, ELYT 470UF 35V
D 10- 12	9A05204100	DIODE, 1N4148
D 14	9A05204100	DIODE, 1N4148
D100, 101	△ 9A05204300	DIODE, PBPC10 10A 100V
D102-109	△ 9A05204200	DIODE, 1N4004
D110, 111	△ 9A05204300	DIODE, PBPC10 10A 100V
D112-115	△ 9A05204200	DIODE, 1N4004
D116	9A05204100	DIODE, 1N4148
D200, 300	9A05204100	DIODE, 1N4148
D201, 301	9A05204100	DIODE, 1N4148
D400	9A05204100	DIODE, 1N4148
D401	9A05204200	DIODE, 1N4004
D402	9A05204100	DIODE, 1N4148
D900	9A05204100	DIODE, 1N4148
F100, 101	△ 9A05207900	FUSE, T6. 3A 250V [E, UK]
F100, 101	△ 9A05208000	FUSE, 6. 3A 125V [C]
F100, 101	△ 9A05212400	FUSE HOLDER
F104, 105	△ 9A05208100	FUSE, T630MA 250V [E, UK]
F104, 105	△ 9A05208200	FUSE, 630MA 125V [C]
F104, 105	△ 9A05212400	FUSE HOLDER
F200, 300	△ 9A05287100	FUSE, F4A 125V [C]
F200, 300	△ 9A05212400	FUSE HOLDER [C]
F201, 301	△ 9A05287100	FUSE, F4A 125V [C]
F201, 301	△ 9A05212400	FUSE HOLDER [C]
J 1- 7	9A05208600	JACK, RCA PHONO 2P GOLD
J 8, 9	9A05208700	XLR FEMALE, NC3FDH-B GOLD
JP 1	9A05306400	CONNECTOR, SIL 2P
K 1, 2	9A05208300	RELAY, DPDT 24V M4-24H
K 4- 7	9A05208300	RELAY, DPDT 24V M4-24H
K 10- 12	9A05208300	RELAY, DPDT 24V M4-24H
K100, 101	9A05208400	RELAY, DPDT 24V/8A
K400, 401	9A05208400	RELAY, DPDT 24V/8A
LEG1, 2	△ 9A05207100	V-REGULATOR, LM317T
LEG3, 5	△ 9A05207200	V-REGULATOR, LM337T
LEG4	△ 9A05207100	V-REGULATOR, LM317T
P 1	9A05207500	CONNECTOR, SIL 6P
P 2	9A05208500	IDC HEADER, 14P
P 10, 11	9A05306500	CONNECTOR, SIL 8P
P100	9A05207800	SCREW TERMINAL, 2X2P
P200, 300	9A05306600	CONNECTOR, SIL 4P+2 JUMPER
P400-403	9A05207600	SOLDER TERMINAL
Q 10, 11	9A05206700	TR, BC337-40
Q 13, 14	9A05206700	TR, BC337-40
Q100	△ 9A05206600	TR, BC327-40
Q200, 300	9A05206800	FET, 2SK170GR
Q201, 301	9A05206800	FET, 2SK170GR
Q202, 302	9A05206400	TR, BC550C
Q203, 303	9A05206600	TR, BC327-40
Q204, 304	9A05206600	TR, BC327-40
Q205, 305	9A05206700	TR, BC337-40
Q206, 306	9A05206600	TR, BC327-40

MAIN PCB ASSY

REF. NO.	PARTS NO.	DESCRIPTION
Q207, 307	9A05206600	TR, BC327-40
Q208, 308	9A05206700	TR, BC337-40
Q209, 309	9A05207000	TR, 2SC3420BL
Q210, 310	9A05207000	TR, 2SC3420BL
Q211, 311	9A05207000	TR, 2SC3420BL
Q212, 312	△ 9A05207400	TR, 2SC39070
Q213, 313	9A05206900	TR, BUP40
Q214, 314	9A05206700	TR, BC337-40
Q215, 315	9A05207000	TR, 2SC3420BL
Q216, 316	△ 9A05207400	TR, 2SC39070
Q217, 317	9A05206900	TR, BUP40
Q218, 318	9A05206600	TR, BC327-40
Q219, 319	9A05206400	TR, BC550C
Q220, 320	9A05206700	TR, BC337-40
Q221, 321	9A05206700	TR, BC337-40
Q222, 322	△ 9A05207400	TR, 2SC39070
Q223, 323	△ 9A05207300	TR, 2SA15160
Q224, 324	△ 9A05207300	TR, 2SA15160
Q225, 325	△ 9A05207400	TR, 2SC39070
Q226, 326	△ 9A05207300	TR, 2SA15160
Q227, 327	△ 9A05207300	TR, 2SA15160
Q228, 328	9A05206600	TR, BC327-40
Q229, 329	9A05206500	TR, BC560C
Q230, 330	9A05206400	TR, BC550C
Q231, 331	9A05206400	TR, BC550C
Q232, 332	9A05206500	TR, BC560C
Q233, 333	9A05206700	TR, BC337-40
Q400	9A05206600	TR, BC327-40
Q401, 402	9A05206700	TR, BC337-40
Q900	9A05206700	TR, BC337-40
R 1	9A05202600	R, MRS25 0. 33W 10K F
R 2	9A05203600	R-NETWORK, SIL 7*10K, 8P
R 4, 5	9A05202600	R, MRS25 0. 33W 10K F
R 7- 9	9A05202200	R, MRS25 0. 33W 3K3 F
R 10	9A05201200	R, MRS25 0. 33W 22R F
R 11	9A05202600	R, MRS25 0. 33W 10K F
R 12	9A05202700	R, MRS25 0. 33W 20K F
R 13	9A05202600	R, MRS25 0. 33W 10K F
R 14	9A05202400	R, MRS25 0. 33W 5K1 F
R 15	9A05201200	R, MRS25 0. 33W 22R F
R 16	9A05202600	R, MRS25 0. 33W 10K F
R 17	9A05202700	R, MRS25 0. 33W 20K F
R 18	9A05202600	R, MRS25 0. 33W 10K F
R 19	9A05202400	R, MRS25 0. 33W 5K1 F
R 20	9A05208800	R, POTMETER 4*20K
R 21- 27	9A05202600	R, MRS25 0. 33W 10K F
R 29	9A05202600	R, MRS25 0. 33W 10K F
R 30, 31	△ 9A05203400	R, PR02 2W 2K2 J
R 32	9A05202700	R, MRS25 0. 33W 20K F
R 33, 34	9A05202200	R, MRS25 0. 33W 3K3 F
R 35	9A05202700	R, MRS25 0. 33W 20K F
R 36- 38	9A05202200	R, MRS25 0. 33W 3K3 F
R100, 101	△ 9A05203400	R, PR02 2W 2K2 J
R102	△ 9A05203300	R, PR02 2W 56R J
R103	△ 9A05203400	R, PR02 2W 2K2 J

MAIN PCB ASSY

REF. NO.	PARTS NO.	DESCRIPTION
R104	△ 9A05203300	R, PR02 2W 56R J
R105	9A05201600	R, MRS25 0.33W 220R F
R106, 107	9A05202300	R, MRS25 0.33W 4K3 F
R108, 109	9A05201600	R, MRS25 0.33W 220R F
R110	9A05202100	R, MRS25 0.33W 2K2 F
R111	9A05202600	R, MRS25 0.33W 10K F
R112	9A05202900	R, MRS25 0.33W 100K F
R113, 114	△ 9A05203300	R, PR02 2W 56R J
R115	9A05201600	R, MRS25 0.33W 220R F
R116, 117	9A05202200	R, MRS25 0.33W 3K3 F
R118	9A05201600	R, MRS25 0.33W 220R F
R119	9A05201700	R, MRS25 0.33W 330R F
R120	△ 9A05203400	R, PR02 2W 2K2 J
R121, 122	△ 9A05203300	R, PR02 2W 56R J
R123	△ 9A05203400	R, PR02 2W 2K2 J
R200, 300	9A05202900	R, MRS25 0.33W 100K F
R201, 301	9A05202900	R, MRS25 0.33W 100K F
R202, 302	9A05201800	R, MRS25 0.33W 390R F
R203, 303	9A05201800	R, MRS25 0.33W 390R F
R204, 304	9A05202500	R, MRS25 0.33W 6K8 F
R205, 305	9A05202500	R, MRS25 0.33W 6K8 F
R206, 306	9A05201400	R, MRS25 0.33W 100R F
R207, 307	9A05201400	R, MRS25 0.33W 100R F
R208, 308	9A05201400	R, MRS25 0.33W 100R F
R209, 309	9A05201300	R, MRS25 0.33W 68R F
R210, 310	9A05202100	R, MRS25 0.33W 2K2 F
R211, 311	9A05201700	R, MRS25 0.33W 330R F
R212, 312	9A05201700	R, MRS25 0.33W 330R F
R213, 313	9A05202700	R, MRS25 0.33W 20K F
R214, 314	9A05202700	R, MRS25 0.33W 20K F
R215, 315	9A05201300	R, MRS25 0.33W 68R F
R216, 316	9A05202800	R, MRS25 0.33W 47K F
R217, 317	9A05201300	R, MRS25 0.33W 68R F
R218, 318	9A05202100	R, MRS25 0.33W 2K2 F
R219, 319	9A05201300	R, MRS25 0.33W 68R F
R220, 320	9A05202600	R, MRS25 0.33W 10K F
R221, 321	9A05201300	R, MRS25 0.33W 68R F
R222, 322	9A05202800	R, MRS25 0.33W 47K F
R223, 323	9A05202100	R, MRS25 0.33W 2K2 F
R224, 324	9A05204000	R, VARIABLE ECP-10 100R
R225, 325	9A05201700	R, MRS25 0.33W 330R F
R226, 326	9A05202600	R, MRS25 0.33W 10K F
R227, 327	9A05202000	R, MRS25 0.33W 1K5 F
R228, 328	9A05202100	R, MRS25 0.33W 2K2 F
R229, 329	9A05204000	R, VARIABLE ECP-10 100R
R230, 330	9A05201700	R, MRS25 0.33W 330R F
R231, 331	9A05202600	R, MRS25 0.33W 10K F
R232, 332	9A05201700	R, MRS25 0.33W 330R F
R233, 333	9A05201500	R, MRS25 0.33W 150R F
R234, 334	9A05201500	R, MRS25 0.33W 150R F
R235, 335	9A05201500	R, MRS25 0.33W 150R F
R236, 336	9A05201500	R, MRS25 0.33W 150R F
R237, 337	9A05201700	R, MRS25 0.33W 330R F
R238, 338	9A05202000	R, MRS25 0.33W 1K5 F
R239, 339	△ 9A05203200	R, PR02 2W 4R7 J

MAIN PCB ASSY

REF. NO.	PARTS NO.	DESCRIPTION
R240, 340	9A05203000	R, MRS25 0.33W 330K F
R241, 341	9A05203000	R, MRS25 0.33W 330K F
R242, 342	9A05203000	R, MRS25 0.33W 330K F
R243, 343	9A05203000	R, MRS25 0.33W 330K F
R244, 344	9A05202600	R, MRS25 0.33W 10K F
R245, 345	9A05202600	R, MRS25 0.33W 10K F
R246, 346	9A05201900	R, MRS25 0.33W 1K F
R247, 347	9A05201900	R, MRS25 0.33W 1K F
R248, 348	9A05201200	R, MRS25 0.33W 22R F
R249, 349	9A05201200	R, MRS25 0.33W 22R F
R250, 350	9A05201300	R, MRS25 0.33W 68R F
R251-257	9A05202600	R, MRS25 0.33W 10K F
R351-357	9A05202600	R, MRS25 0.33W 10K F
R258, 358	9A05201800	R, MRS25 0.33W 390R F
R259, 359	9A05201800	R, MRS25 0.33W 390R F
R260, 360	9A05202700	R, MRS25 0.33W 20K F
R261, 361	△ 9A05203500	R, PR02 2W 0R22 J [E, UK]
R262, 362	△ 9A05203500	R, PR02 2W 0R22 J [E, UK]
R400-403	9A05203100	R, MRS25 0.33W 1M F
R404	9A05203700	R-NETWORK, DIL 8*100K, 16P
R405-408	9A05202200	R, MRS25 0.33W 3K3 F
R409, 410	9A05202900	R, MRS25 0.33W 100K F
R411	9A05202600	R, MRS25 0.33W 10K F
R412	9A05202900	R, MRS25 0.33W 100K F
R413-416	9A05201200	R, MRS25 0.33W 22R F
R417	9A05202800	R, MRS25 0.33W 47K F
R418	9A05202400	R, MRS25 0.33W 5K1 F
R502	9A05203000	R, MRS25 0.33W 330K F
R503	9A05202500	R, MRS25 0.33W 6K8 F
R504	9A05202300	R, MRS25 0.33W 4K3 F
R505	9A05202500	R, MRS25 0.33W 6K8 F
R506	9A05203800	R, NTC 22K J
R507	9A05202200	R, MRS25 0.33W 3K3 F
R508	9A05202500	R, MRS25 0.33W 6K8 F
R509	9A05203000	R, MRS25 0.33W 330K F
R702	9A05201100	R, MRS25 0.33W 0R F
R900	9A05202700	R, MRS25 0.33W 20K F
R901, 902	9A05202200	R, MRS25 0.33W 3K3 F
R903	9A05202700	R, MRS25 0.33W 20K F
R904, 905	9A05202200	R, MRS25 0.33W 3K3 F
S 1, 2	9A05207700	PCB WASHER, M3.5
U 1- 4	9A05206100	IC, HEF4073
U 5, 6	9A05206000	IC, HEF4044
U 10- 12	9A05205900	IC, OP275
U 80, 81	9A05205900	IC, OP275
U200, 300	9A05205800	IC, MC1458
U400	9A05206300	IC, HEF4093
U401	9A05206200	IC, HEF4075
U500	9A05205800	IC, MC1458
VR200, 300	△ 9A05203900	RESET FUSE, T3A MF-R300 [E, UK]
VR201, 301	△ 9A05203900	RESET FUSE, T3A MF-R300 [E, UK]
Z 1	9A05204600	ZENER DIODE, 0.33W 12V
Z100	9A05204600	ZENER DIODE, 0.33W 12V
Z200, 300	9A05204500	ZENER DIODE, 0.33W 5V6
Z201, 301	9A05204500	ZENER DIODE, 0.33W 5V6

A-BX10/PA-B10

MAIN PCB ASSY

REF. NO.	PARTS NO.	DESCRIPTION
Z400, 401	9A05204600	ZENER DIODE, 0.33W 12V
Z402	9A05204400	ZENER DIODE, 0.33W 2V7
Z403, 404	9A05204500	ZENER DIODE, 0.33W 5V6
Z405	9A05204400	ZENER DIODE, 0.33W 2V7
Z406, 407	9A05204500	ZENER DIODE, 0.33W 5V6

FRONT PANEL PCB ASSY

REF. NO.	PARTS NO.	DESCRIPTION
	9A05210900	FRONT PANEL PCB ASSY
D1	9A05209000	LED, RED/GREEN
JP1	9A05209100	DIP CONNECTOR, 14P
SW1, 2	9A05208900	SW, SELECTOR 1*12
SW3	9A05209200	SW, PUSH B170G

MAIN CONNECTOR PCB ASSY

REF. NO.	PARTS NO.	DESCRIPTION
	9A05211000	MAIN CONNECTOR PCB ASSY
C2	△ 9A05209800	C, ELYT 3300UF 6V3
D1, 2	△ 9A05209600	DIODE, 1N5400
P1	9A05209700	SCREW TERMINAL, 2P
P2	9A05207800	SCREW TERMINAL, 2X2P
R1	△ 9A05209500	R, VDR 275VAC
R2	△ 9A05306700	R, MRS25 0.33W 470K F
R3	△ 9A05209400	R, NTC 10 OHM/7A

BAL RIAA MM/MC PCB ASSY

REF. NO.	PARTS NO.	DESCRIPTION
	9A05272300	BAL RIAA MM/MC PCB ASSY
D 1	9A05204100	DIODE, 1N4148
K 1, 101	9A05208300	RELAY, DPDT 24V M4-24H
P 1	9A05274000	CONNECTOR ASSY, 8P 40MM
P 2	9A05274100	CONNECTOR ASSY, 8P 80MM
Q 1, 101	9A05273800	TR, 2SC3329BL
Q 2, 102	9A05273800	TR, 2SC3329BL
Q 3, 103	9A05273800	TR, 2SC3329BL
Q 4, 104	9A05273800	TR, 2SC3329BL
Q 5, 105	9A05206400	TR, BC550C
Q 6, 106	9A05206400	TR, BC550C
Q 7, 107	9A05206400	TR, BC550C
Q 8, 108	9A05206500	TR, BC560C
R 1, 101	9A05272500	R, MRS25 0.33W 33R F
R 2, 102	9A05201400	R, MRS25 0.33W 100R F
R 3, 103	9A05272400	R, MRS25 0.33W 15R F
R 4, 104	9A05202800	R, MRS25 0.33W 47K F
R 5, 105	9A05273000	R, MRS25 0.33W 2.2M F
R 6, 106	9A05272800	R, MRS25 0.33W 7K5 F
R 7, 107	9A05202000	R, MRS25 0.33W 1K5 F
R 8, 108	9A05202000	R, MRS25 0.33W 1K5 F
R 9, 109	9A05201800	R, MRS25 0.33W 390R F
R 10, 110	9A05272600	R, MRS25 0.33W 47R F
R 11, 111	9A05272600	R, MRS25 0.33W 47R F
R 12, 112	9A05272700	R, MRS25 0.33W 2K0 F
R 13, 113	9A05272900	R, MRS25 0.33W 22K F
R 14, 114	9A05272900	R, MRS25 0.33W 22K F
R 15, 115	9A05201800	R, MRS25 0.33W 390R F
R 16, 116	9A05201800	R, MRS25 0.33W 390R F
R 17, 117	9A05273200	R, MRS25 0.33W 56K2 F
R 18, 118	9A05209300	R, MRS25 0.33W 12K4 F
R 19, 119	9A05273200	R, MRS25 0.33W 56K2 F
R 20, 120	9A05203100	R, MRS25 0.33W 1M F
R 21, 121	9A05203100	R, MRS25 0.33W 1M F
R 22, 122	9A05203100	R, MRS25 0.33W 1M F
R 23, 123	9A05203100	R, MRS25 0.33W 1M F
R 24, 124	9A05273100	R, MRS25 0.33W 9K76 F
R 25, 125	9A05273100	R, MRS25 0.33W 9K76 F
R 26, 126	9A05201800	R, MRS25 0.33W 390R F
R 27, 127	9A05201800	R, MRS25 0.33W 390R F
R 28, 128	9A05272900	R, MRS25 0.33W 22K F
R 29, 129	9A05202000	R, MRS25 0.33W 1K5 F
R 30, 130	9A05202000	R, MRS25 0.33W 1K5 F
SW 1, 2	9A05274200	SW, 4WAY+KNOB
U 1, 101	9A05205900	IC, OP275
U 2, 102	9A05205900	IC, OP275
U 3, 103	9A05273900	IC, LM358N

MAIN PCB

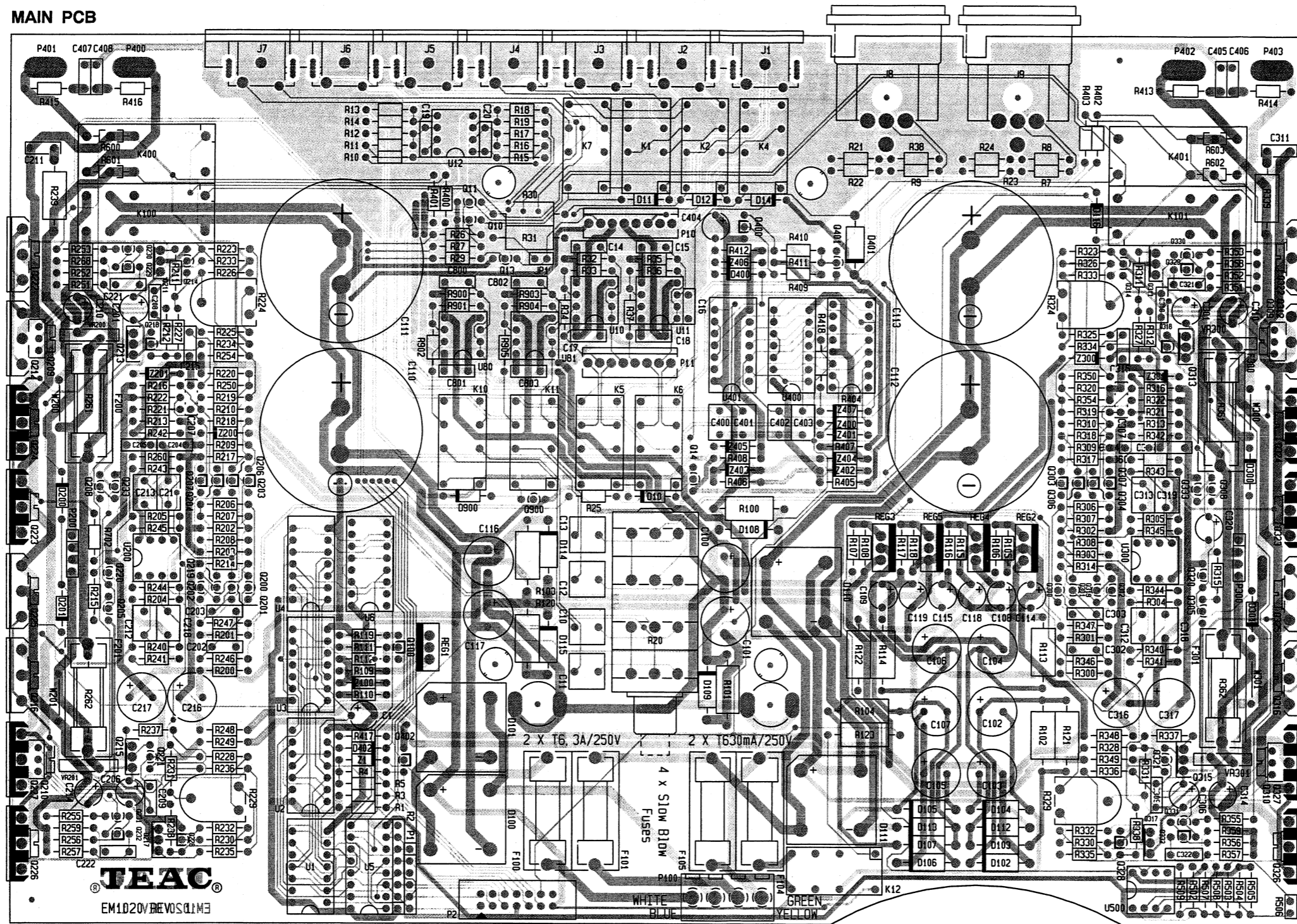

FRONT PANEL PCB

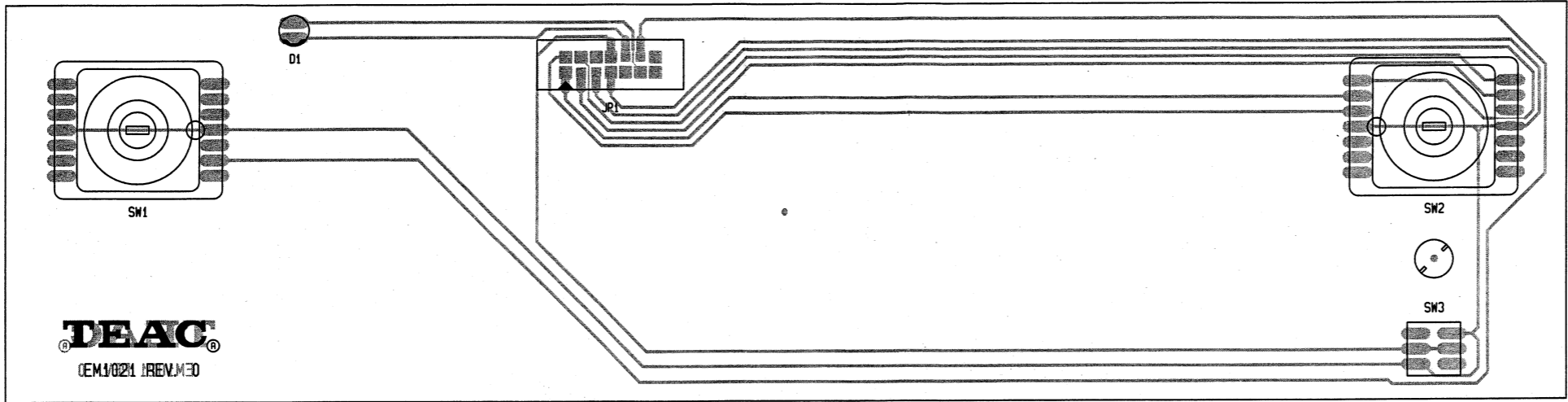

MAIN CONNECTOR PCB

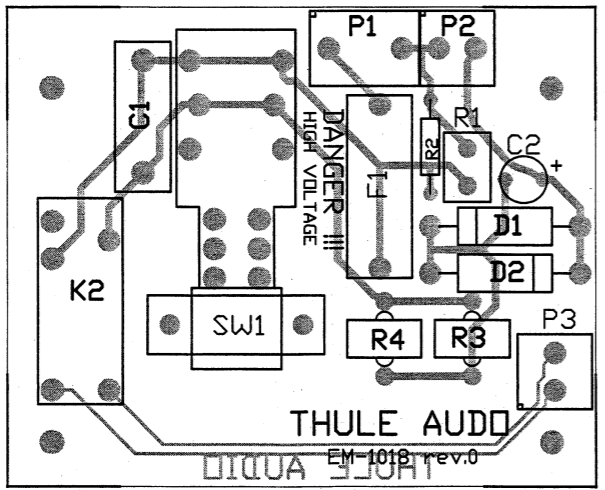

BALANCED RIAA MM/MC PCB

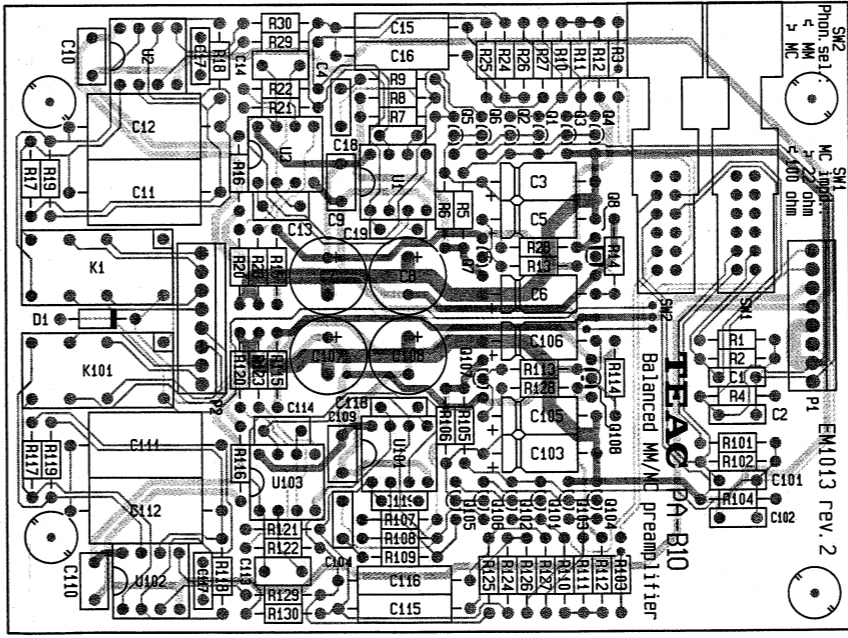

TEAC SCHEMATIC DIAGRAM PA-B10

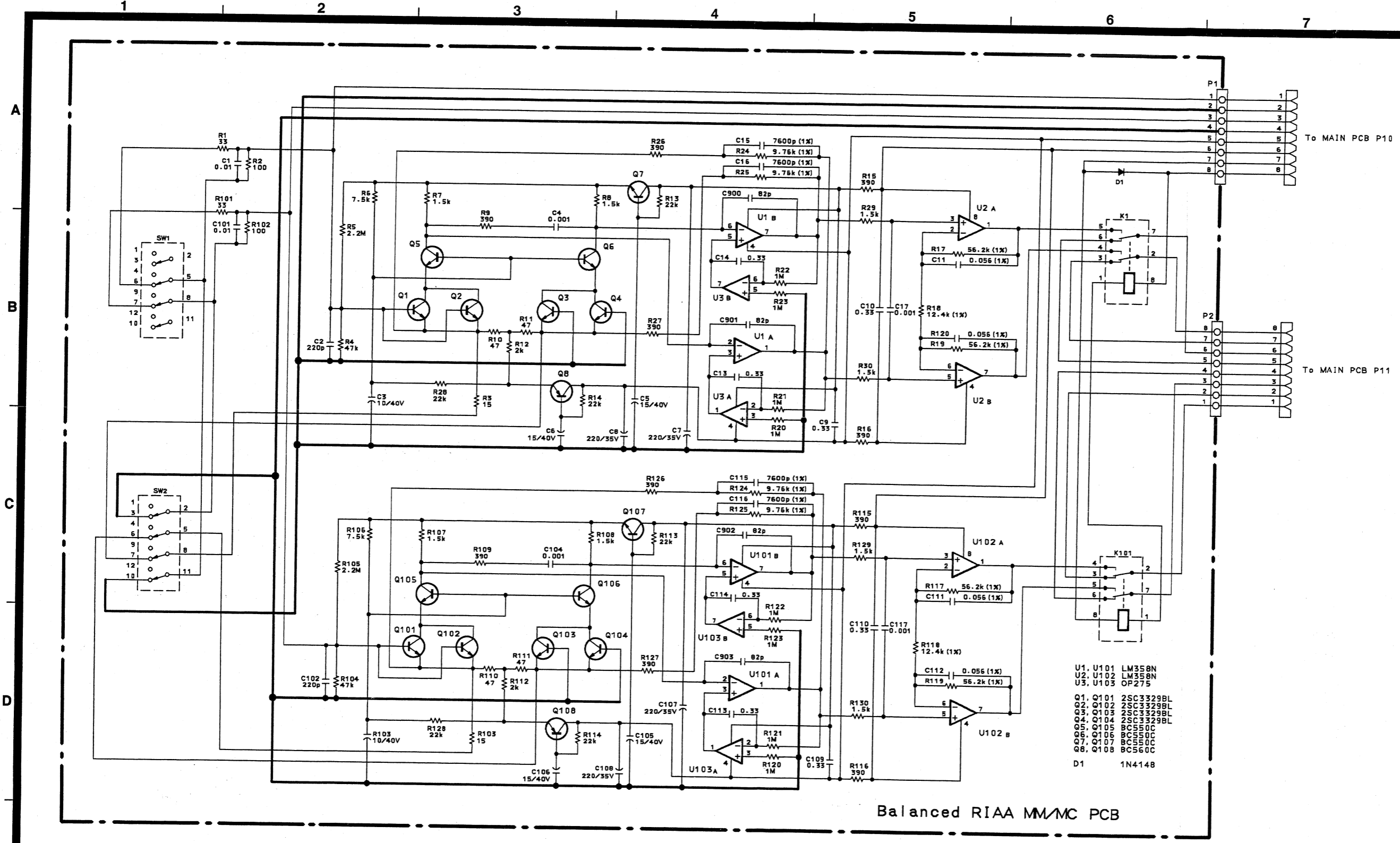

- U1, U101 LM358N
- U2, U102 LM358N
- U3, U103 OP275
- Q1, Q101 2SC3329BL
- Q2, Q102 2SC3329BL
- Q3, Q103 2SC3329BL
- Q4, Q104 2SC3329BL
- Q5, Q105 BC550C
- Q6, Q106 BC550C
- Q7, Q107 BC550C
- Q8, Q108 BC560C
- D1 1N4148

Balanced RIAA MM/MC PCB

INSTRUCTIONS FOR SERVICE PERSONNEL
 BEFORE RETURNING APPLIANCE TO THE CUSTOMER, MAKE LEAKAGE-CURRENT OR RESISTANCE MEASUREMENTS TO DETERMINE THAT EXPOSED PARTS ARE ACCEPTABLY INSULATED FROM THE SUPPLY CIRCUIT.

- NOTES:**
1. Resistor values are in ohms (k=kilo-ohms, M=megohms).
 2. Capacitor values are in microfarads (p=picofarads).
 3. Δ Parts marked with this sign are safety critical components. They must always be replaced with identical components—refer to the appropriate parts list and ensure exact replacement.

PA-B10

Balanced MM/MC Preamplifier

1st Issue; April 1995

TEAC SCHEMATIC DIAGRAM A-BX10

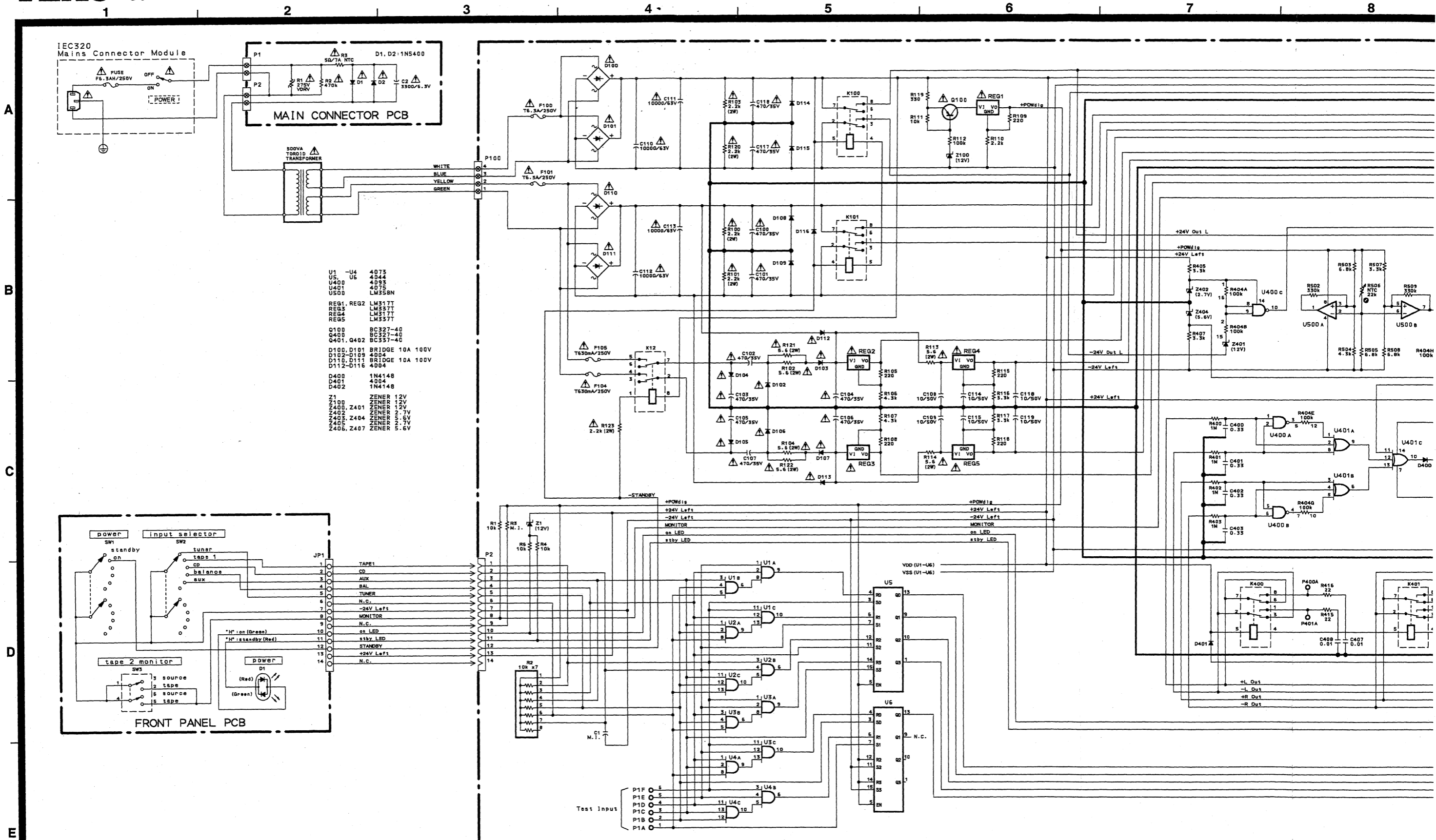

U1 -U4	4073
U5, U6	4044
U400	4093
U401	4075
U500	LM358N
REG1, REG2	LM317T
REG3	LM337T
REG4	LM317T
REG5	LM337T
Q100	BC327-40
Q400	BC327-40
Q401, Q402	BC337-40
D100, D101	BRIDGE 10A 100V
D102-D109	4004
D110, D111	BRIDGE 10A 100V
D112-D116	4004
D400	1N4148
D401	4004
D402	1N4148
Z1	ZENER 12V
Z100	ZENER 12V
Z400, Z401	ZENER 12V
Z402	ZENER 2.7V
Z403, Z404	ZENER 5.6V
Z405	ZENER 2.9V
Z406, Z407	ZENER 5.6V

INSTRUCTIONS FOR SERVICE PERSONNEL
BEFORE RETURNING APPLIANCE TO THE CUSTOMER, MAKE LEAKAGE-CURRENT OR RESISTANCE MEASUREMENTS TO DETERMINE THAT EXPOSED PARTS ARE ACCEPTABLY INSULATED FROM THE SUPPLY CIRCUIT.

NOTES:
 1. Resistor values are in ohms (k=kilo-ohms, M=megohms).
 2. Capacitor values are in microfarads (p=picofarads).
 3. Δ Parts marked with this sign are safety critical components. They must always be replaced with identical components-refer to the appropriate parts list and ensure exact replacement.

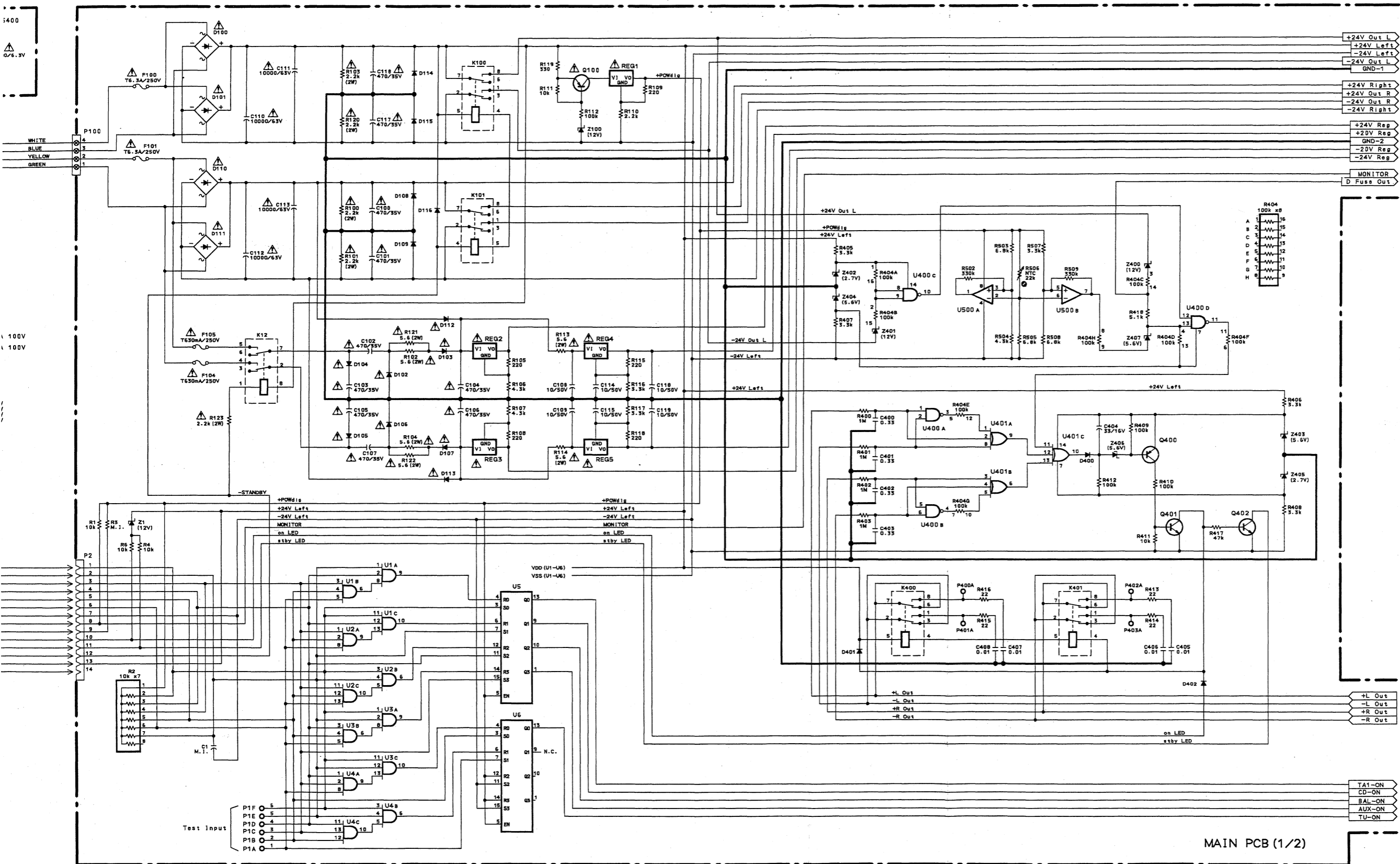

NOTES:
 1. Resistor values are in ohms (k=kilo-ohms, M=megohms).
 2. Capacitor values are in microfarads (p=picofarads).
 3. Δ Parts marked with this sign are safety critical components. They must always be replaced with identical components-refer to the appropriate parts list and ensure exact replacement.

MAIN PCB (1/2)

A-BX10

Integrated Stereo Amplifier

1st Issue; April 1995

TEAC SCHEMATIC DIAGRAM A-BX10

1 2 3 4 5 6 7 8

A
B
C
D
E

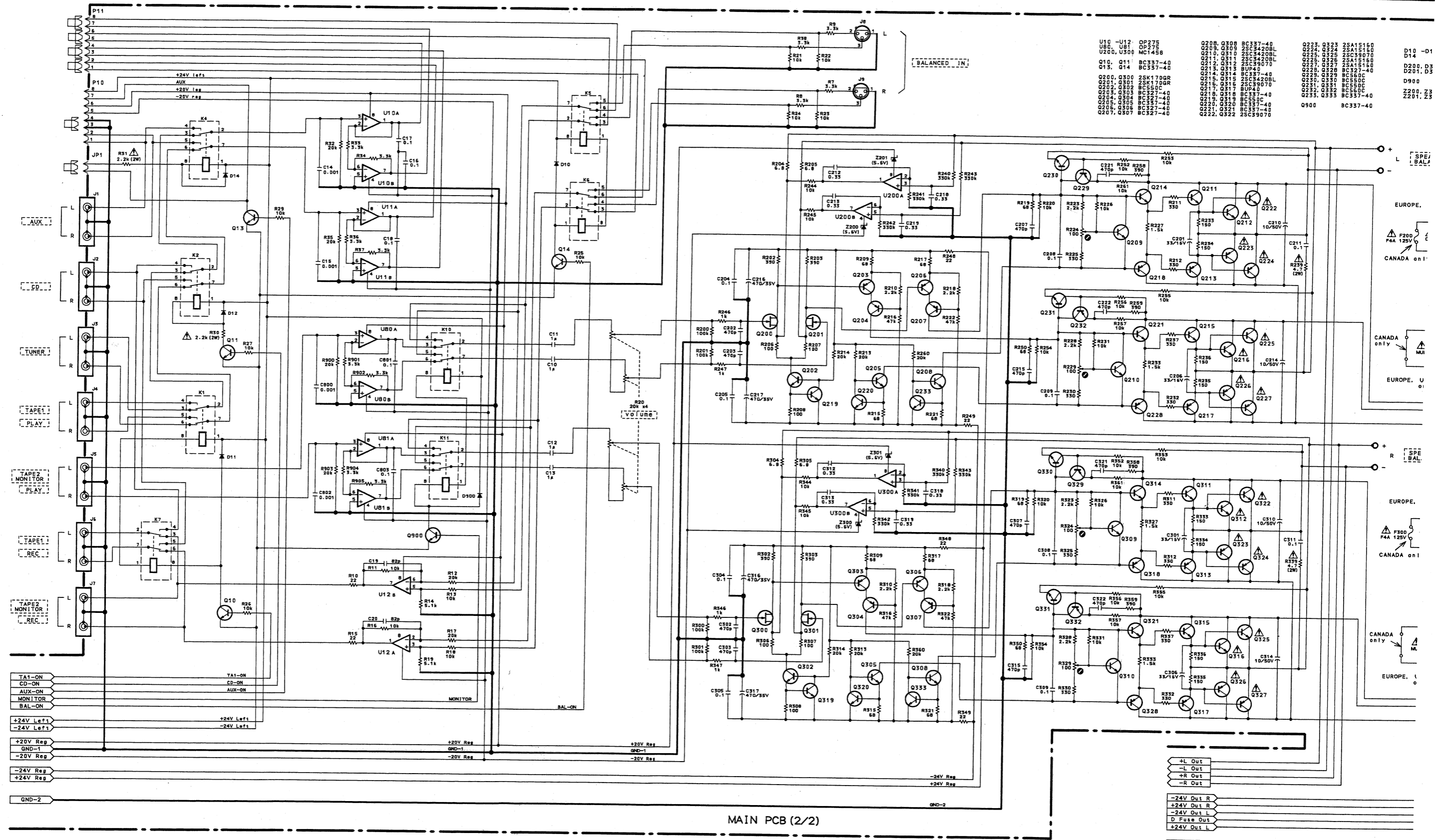

U10 -U12	OP275	Q208, Q308	BC337-40	Q223, Q323	2SA1516	D10 -D1
U80, U81	OP275	Q209, Q309	2SC3420BL	Q224, Q324	2SA1516	D14
U200, U300	MC1458	Q210, Q310	2SC3420BL	Q225, Q325	2SC3970	D200, D3
Q10, Q11	BC337-40	Q211, Q311	2SC3420BL	Q226, Q326	2SA1516	D201, D3
Q13, Q14	BC337-40	Q212, Q312	2SC3970	Q227, Q327	2SA1516	D900
Q200, Q300	2SK170GR	Q213, Q313	8UP40	Q228, Q328	BC337-40	Z200, Z3
Q201, Q301	2SK170GR	Q214, Q314	BC337-40	Q229, Q329	BC550C	Z201, Z3
Q202, Q302	BC550C	Q215, Q315	2SC3970	Q230, Q330	BC550C	
Q203, Q303	BC337-40	Q216, Q316	2SC3970	Q231, Q331	BC550C	
Q204, Q304	BC337-40	Q217, Q317	8UP40	Q232, Q332	BC550C	
Q205, Q305	BC337-40	Q218, Q318	BC337-40	Q233, Q333	BC337-40	
Q206, Q306	BC337-40	Q219, Q319	BC550C	Q234, Q334	BC337-40	
Q207, Q307	BC337-40	Q220, Q320	BC550C	Q235, Q335	BC337-40	
		Q221, Q321	BC337-40	Q236, Q336	BC337-40	
		Q222, Q322	2SC3970	Q237, Q337	BC337-40	
		Q223, Q323	BC337-40	Q238, Q338	BC337-40	
		Q224, Q324	2SC3970	Q239, Q339	BC337-40	
		Q225, Q325	2SC3970	Q240, Q340	BC337-40	
		Q226, Q326	2SA1516	Q241, Q341	BC337-40	
		Q227, Q327	2SA1516	Q242, Q342	BC337-40	
		Q228, Q328	BC337-40	Q243, Q343	BC337-40	
		Q229, Q329	BC550C	Q244, Q344	BC337-40	
		Q230, Q330	BC550C	Q245, Q345	BC337-40	
		Q231, Q331	BC550C	Q246, Q346	BC337-40	
		Q232, Q332	BC337-40	Q247, Q347	BC337-40	
		Q233, Q333	BC337-40	Q248, Q348	BC337-40	
		Q234, Q334	BC337-40	Q249, Q349	BC337-40	
		Q235, Q335	BC337-40	Q250, Q350	BC337-40	
		Q236, Q336	BC337-40	Q251, Q351	BC337-40	
		Q237, Q337	BC337-40	Q252, Q352	BC337-40	
		Q238, Q338	BC337-40	Q253, Q353	BC337-40	
		Q239, Q339	BC337-40	Q254, Q354	BC337-40	
		Q240, Q340	BC337-40	Q255, Q355	BC337-40	
		Q241, Q341	BC337-40	Q256, Q356	BC337-40	
		Q242, Q342	BC337-40	Q257, Q357	BC337-40	
		Q243, Q343	BC337-40	Q258, Q358	BC337-40	
		Q244, Q344	BC337-40	Q259, Q359	BC337-40	
		Q245, Q345	BC337-40	Q260, Q360	BC337-40	
		Q246, Q346	BC337-40	Q261, Q361	BC337-40	
		Q247, Q347	BC337-40	Q262, Q362	BC337-40	
		Q248, Q348	BC337-40	Q263, Q363	BC337-40	
		Q249, Q349	BC337-40	Q264, Q364	BC337-40	
		Q250, Q350	BC337-40	Q265, Q365	BC337-40	
		Q251, Q351	BC337-40	Q266, Q366	BC337-40	
		Q252, Q352	BC337-40	Q267, Q367	BC337-40	
		Q253, Q353	BC337-40	Q268, Q368	BC337-40	
		Q254, Q354	BC337-40	Q269, Q369	BC337-40	
		Q255, Q355	BC337-40	Q270, Q370	BC337-40	

INSTRUCTIONS FOR SERVICE PERSONNEL
 BEFORE RETURNING APPLIANCE TO THE CUSTOMER, MAKE LEAKAGE-CURRENT OR RESISTANCE MEASUREMENTS TO DETERMINE THAT EXPOSED PARTS ARE ACCEPTABLY INSULATED FROM THE SUPPLY CIRCUIT.

NOTES:
 1. Resistor values are in ohms (k=kilo-ohms, M=megohms).
 2. Capacitor values are in microfarads (p=picofarads).
 3. Δ Parts marked with this sign are safety critical components. They must always be replaced with identical components-refer to the appropriate parts list and ensure exact replacement.

MAIN PCB (2/2)

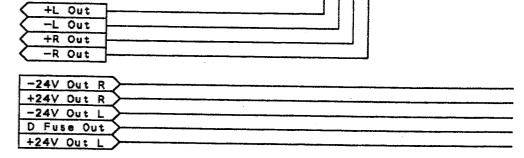

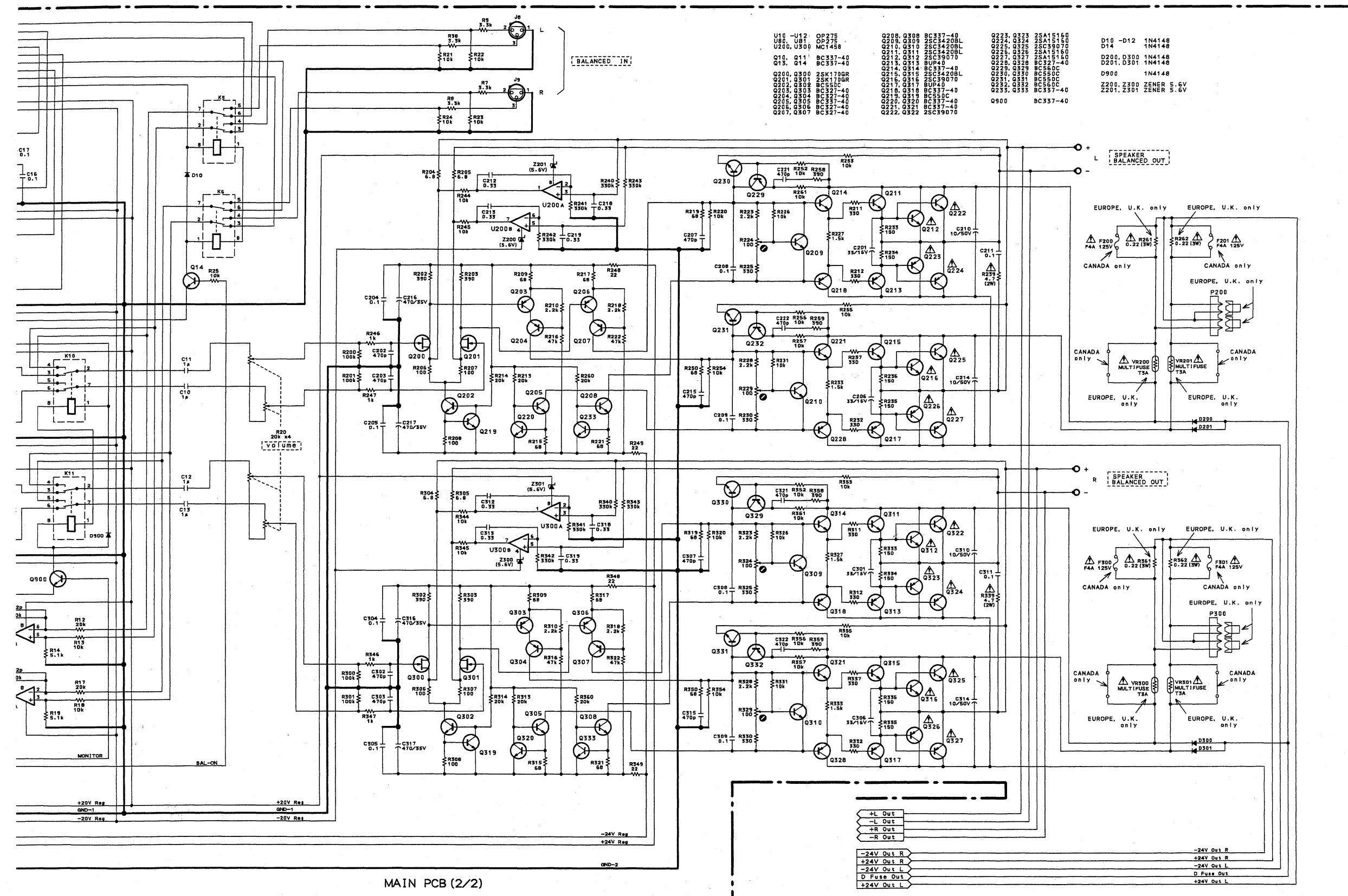

U10 -U12	OP275	Q208, Q308	BC337-40	Q223, Q323	2SA15160
U80, U81	OP275	Q209, Q309	2SC4208L	Q224, Q324	2SA15170
U10, U500	MC1458	Q210, Q310	2SC14208L	Q225, Q325	2SA15170
Q10, Q11	BC337-40	Q211, Q311	2SC14208L	Q226, Q326	2SA15180
Q13, Q14	BC337-40	Q212, Q312	2SC14208L	Q227, Q327	2SA15180
Q200, Q300	2SK1708R	Q213, Q313	2SC14208L	Q228, Q328	BC327-40
Q201, Q301	2SK1708R	Q214, Q314	BC337-40	Q229, Q329	BC337-40
Q202, Q302	BC550C	Q215, Q315	2SC39070	Q230, Q330	BC550C
Q203, Q303	BC327-40	Q216, Q316	2SC39070	Q231, Q331	BC550C
Q204, Q304	BC327-40	Q217, Q317	80P40	Q232, Q332	BC550C
Q205, Q305	BC327-40	Q218, Q318	BC337-40	Q233, Q333	BC337-40
Q206, Q306	BC327-40	Q219, Q319	BC337-40	Q900	BC337-40
Q207, Q307	BC327-40	Q220, Q320	BC337-40		
		Q221, Q321	BC337-40		
		Q222, Q322	2SC39070		

NOTES:
 1. Resistor values are in ohms (k=kilo-ohms, M=megohms).
 2. Capacitor values are in microfarads (p=picofarads).
 3. Δ Parts marked with this sign are safety critical components. They must always be replaced with identical components-refer to the appropriate parts list and ensure exact replacement.

A-BX10

Integrated Stereo Amplifier

1st Issue; April 1995

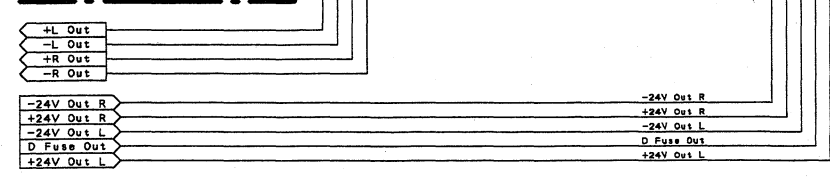

5 INCLUDED ACCESSORIES

INCLUDED ACCESSORIES

REF. NO.	PARTS NO.	DESCRIPTION	REMARKS
	△ 9A05211100	POWER CORD [E]	
	△ 9A05211200	POWER CORD [C]	
	△ 9A05211300	POWER CORD [UK]	
	9A05038600	OWNER'S MANUAL, 6M	A-BX10
	9A05066300	OWNER'S MANUAL, 6M	PA-B10