

TEAC

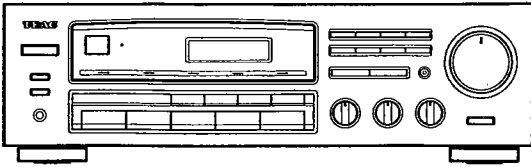

SERVICE MANUAL

AG-360

AM/FM Stereo Receiver

For U.S.A.

NOTES

- PC boards shown are viewed from parts side.
- The parts with no reference number or no parts number in the exploded views are not supplied.
- As regards the resistors and capacitors, refer to the circuit diagrams contained in this manual.
- Δ Parts marked with this sign are safety critical components. They must be replaced with identical components - refer to the appropriate parts list and ensure exact replacement.

1 SPECIFICATIONS

Amplifier Section

Output Power (Front):

50 watts per channel minimum RMS, both channels driven into 8 ohms from 50 Hz to 20 kHz with no more than 0.9% total harmonic distortion

Total Harmonic Distortion:

0.05% at 20 watts

Input Sensitivity/Impedance:

PHONO: 2.5 mV/47 k ohms

AUX, CD, TAPE: 200 mV/20 k ohms

Frequency Response:

PHONO: 20 Hz - 20 kHz, ± 1 dB

AUX, CD, TAPE: 10 Hz - 40 kHz, ± 1 -3 dB

Signal-to-Noise Ratio (IHF A Network):

PHONO: 80 dB

AUX, CD, TAPE: 85 dB

Tone Control:

BASS: ± 10 dB at 100 Hz

TREBLE: ± 10 dB at 10 kHz

Loudness Control (Volume at -30 dB Position):

+7 dB at 100 Hz, +4 dB at 10 kHz

FM Tuner Section

Tuning Range:

87.5 MHz - 108.0 MHz (100 kHz steps)

Usable Sensitivity (IHF):

Mono: 14.7 dBf

50 dB Quieting Sensitivity:

Mono: 22.1 dBf / Stereo: 42.1 dBf

Capture Ratio: 3.0 dB

Image Rejection Ratio: 30 dB

AM Suppression Ratio (1 kHz): 60 dB

Harmonic Distortion (1 kHz):

Mono: 0.5% / Stereo: 0.9%

Frequency Response:

30 Hz - 13 kHz, ± 0.5 -3 dB

Stereo Separation (1 kHz): 35 dB

Signal-to-Noise Ratio:

Mono: 65 dB / Stereo: 62 dB

IF Rejection Ratio: 60 dB

AM Tuner Section

Tuning Range:

520 kHz - 1,710 kHz (10 kHz steps)

Usable Sensitivity: 60 dB/m

Selectivity: 20 dB ± 10 kHz

Signal-to-Noise Ratio: 40 dB

General

Power Requirements:

120 V AC, 60 Hz

Dimensions (WxHxD):

435 x 132 x 333 mm

(17-1/8" x 5-3/16" x 13-1/8")

Weight (net): 7.0 kg (15-7/16 lbs.)

Standard Accessories:

AM Loop Antenna x 1

FM "T" Type Antenna x 1

- Improvements may result in specifications and features changing without notice.
- Illustrations may differ slightly from production models.

2 ADJUSTMENTS

2-1 Adjustments and Test Points

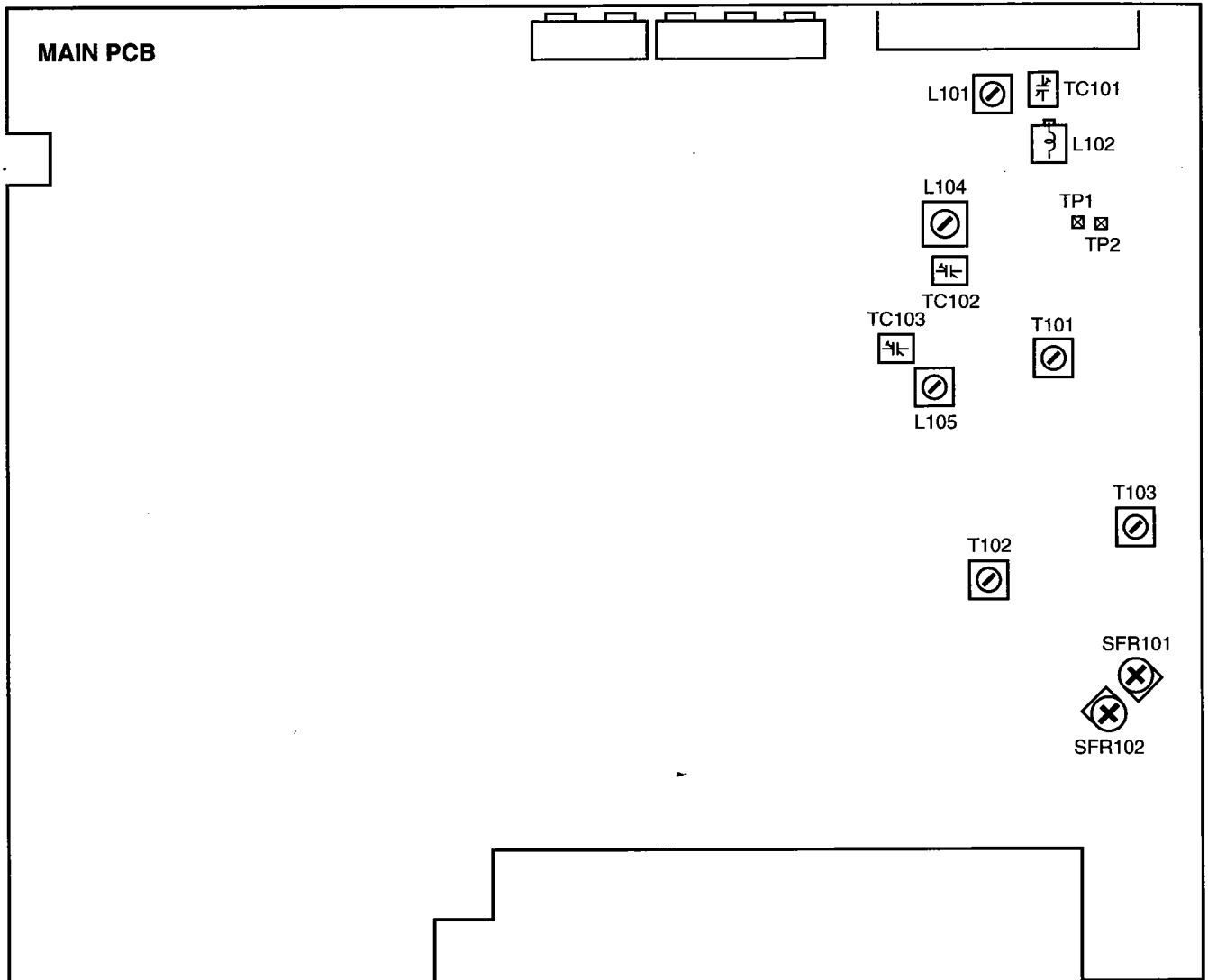

Fig. 2-1

2-2 Adjustment Procedure

ITEM	SETTING			ADJUSTMENT POINTS	ADJUST
	INPUT	OUTPUT	AG-360		
1. VT Adjust	/	A TP 2 (VT) TP 1 (GND)	FM 87.5 MHz	L102	DC 1.2V
			FM 108.0 MHz	Check	DC 8.0V~8.5V
			AM 520 kHz	L105	DC 1.1±0.05V
			AM 1710 kHz	TC103	≤ 8.0V
			After adjusting TC103, readjust L105, then check that the DC voltage are 8 V or less at 1710 kHz.		
2. AM Sensitivity	B 600 kHz/1400 kHz 50 dB/m 400 Hz (30 % Mod)	C REC OUT	AM 600 kHz	L104	Max.
			AM 1400 kHz	TC102	Max.
			After adjusting TC102, readjust L104 at 600 kHz.		
3. AM IF	B 1000 kHz 50 dB/m 400 Hz (30 % Mod)	C REC OUT	AM 1000 kHz	T102	Max.
4. FM Sensitivity	D 90 MHz/106 MHz 10~20 dBf 1 kHz (100 % Mod)	F REC OUT	FM 90 MHz	L101	Max.
			FM 106 MHz	TC101	Max.
			After adjusting TC101, readjust L101 at 90 MHz.		
5. FM Distortion	D 98 MHz 60 dBf 1 kHz (100 % Mod)	G REC OUT	FM 98 MHz	T103	Min. distortion
6. FM IF	D 98 MHz 10~20 dBf 1 kHz (100 % Mod)	H REC OUT	FM 98 MHz	T101	Fig. 2-5
7. FM Stereo	D E 98 MHz 65 dBf Stereo signal	F REC OUT	FM 98 MHz	SFR101	Min. crosstalk
8. Auto Seek	D 98 MHz 35 dBf 1 kHz (30 % Mod)	/	FM 98 MHz	SFR102	Auto stop

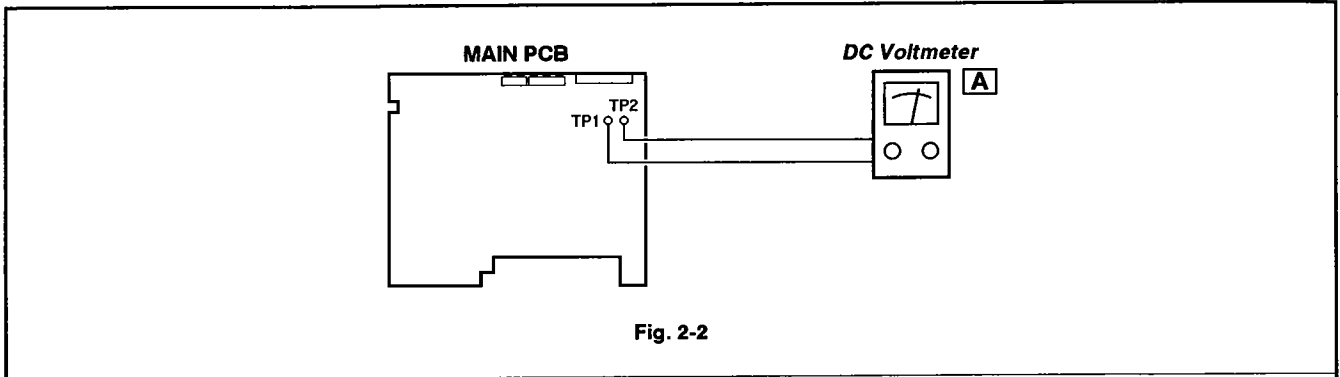

Fig. 2-2

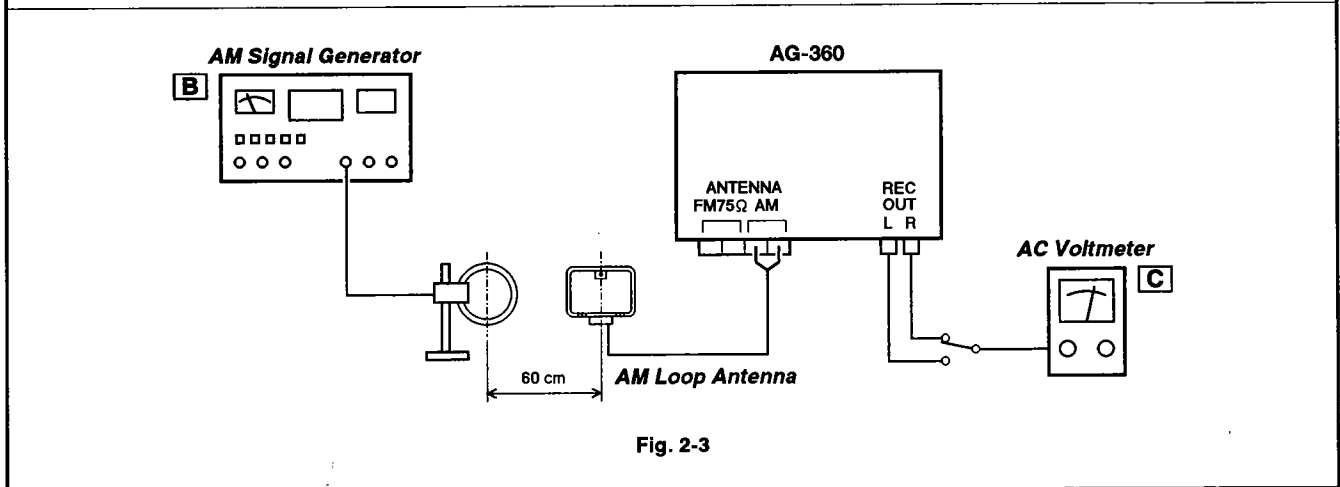

Fig. 2-3

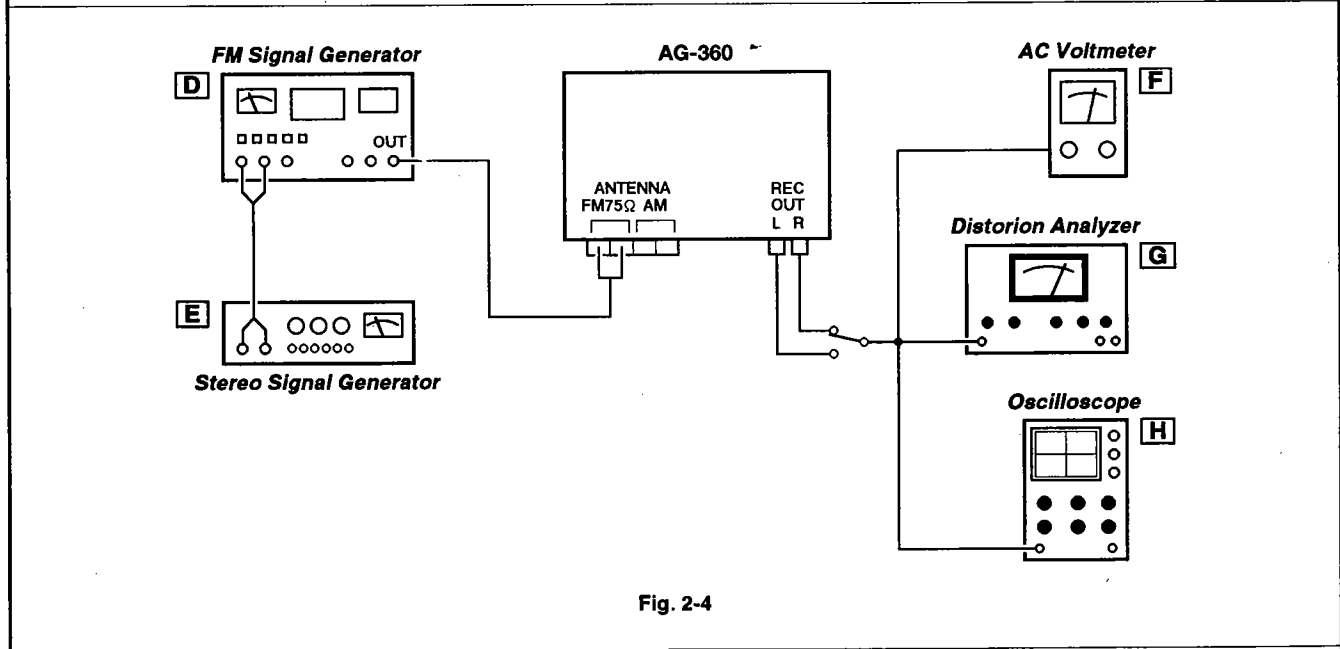

Fig. 2-4

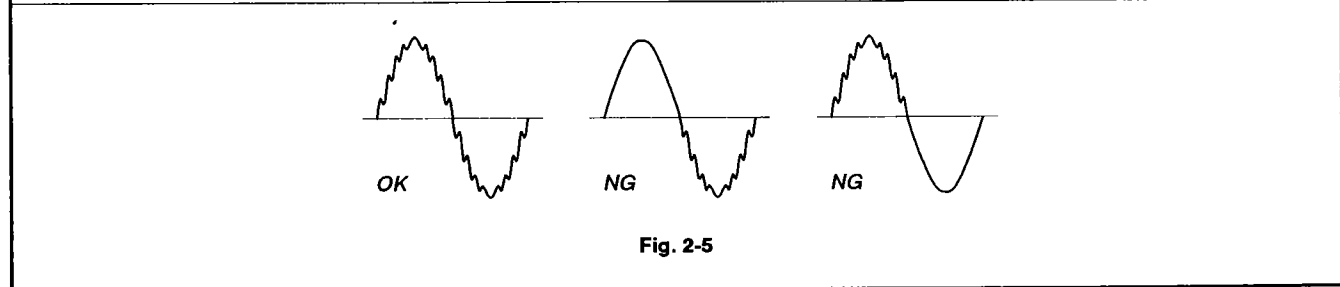
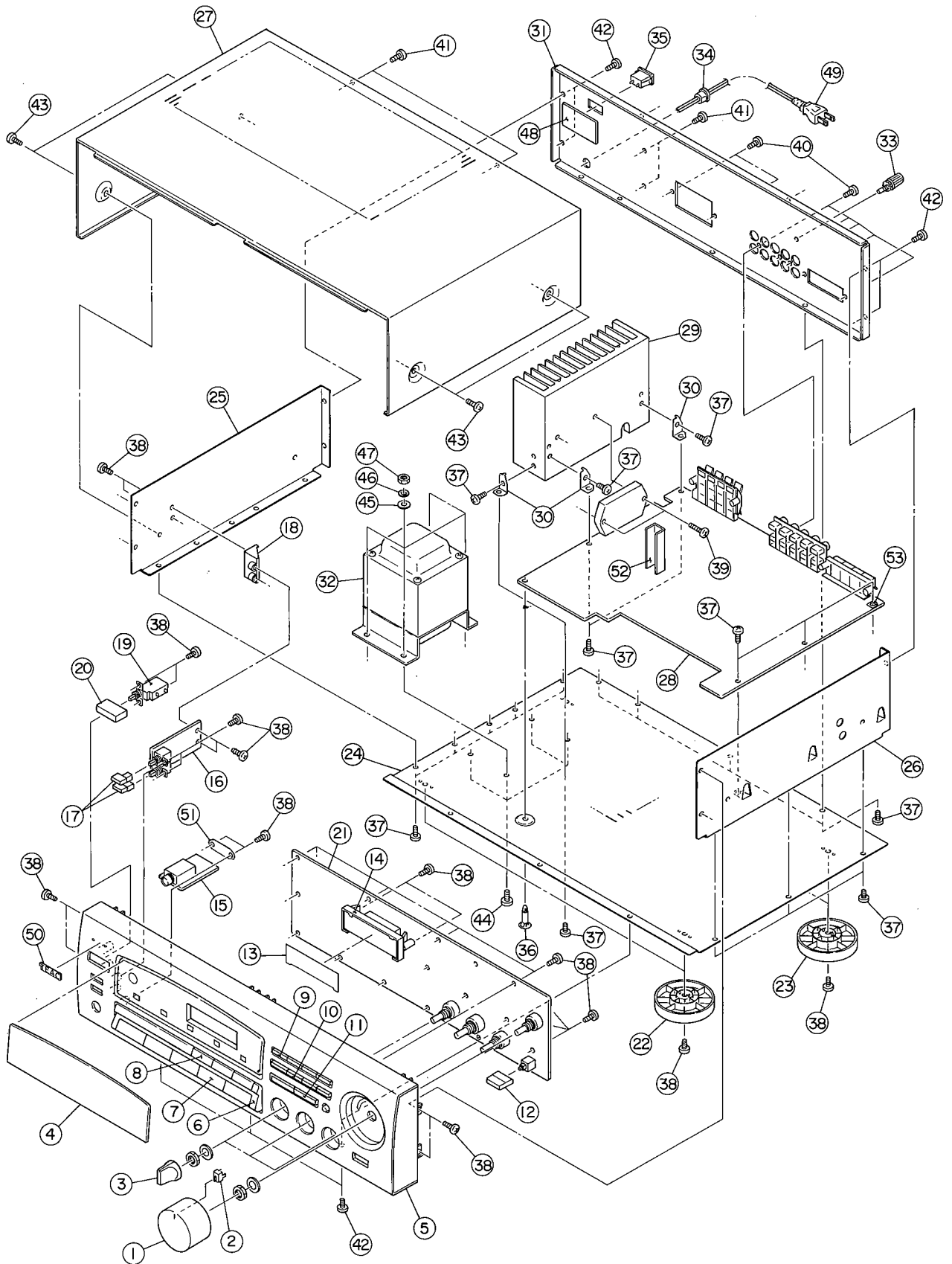

Fig. 2-5

3 EXPLODED VIEWS AND PARTS LIST

EXPLODED VIEW-1



EXPLODED VIEW-1

REF. NO.	PARTS NO.	DESCRIPTION	REMARKS
1	9A06536200	MASTER VR KNOB	
2	9A06900300	INDICATOR	
3	9A06536100	TONE CON KNOB	
4	9A06535300	WINDOW	
5	9A06535200	FRONT PANEL	
6	9A06900200	PUSH KNOB FRAM	
7	9A06535400	FUNCTION KNOB	
8	9A06535500	BAND KNOB	
9	9A06535700	MEMORY KEY 1-4	
10	9A06535800	MEMORY KEY 5-8	
11	9A06535600	TUNING KNOB	
12	9A06536000	LOUD KNOB	
13	9A06901500	DISPLAY FILTER	
14	9A06900400	DISPLAY HOLDER	
15	9A07063200	HEAD PHONE PCB ASSY	
16	9A07063300	SPEAKER SELECTOR PCB ASSY	
17	9A07063400	SPEAKER SWITCH KNOB	
18	9A06900500	SPEAKER SELECTOR PCB HOLDER	
19	△ 9A06602800	POWER SWITCH	
20	9A06535900	POWER KNOB	
21	9A07063000	FRONT PCB ASSY	
22	9A06536400	LEG (HOT STAMP)	
23	9A06536300	LEG (BLACK)	
24	9A06900800	BOTTOM COVER	
25	9A06901000	SIDE BRACKET (L)	
26	9A06901100	SIDE BRACKET (R)	
27	9A06536500	TOP COVER	
28	9A07062900	MAIN PCB ASSY	
29	9A06901300	HEAT SINK (B) POWER IC	
30	9A06901200	H/S BRACKET	
31	9A06900900	REAR COVER	
32	△ 9A06625900	POWER TRANS, 117V	
	△ 9A07069400	POWER TRANS, 230V/115V	SOUTH AMERICA
33	9A06904300	GND TERMINAL, M3	
34	△ 9A06900600	CORD BUSHING	
35	△ 9A06602900	AC SOCKET, S-16519-02	
36	9A06900500	SPACER SUPPORT	
37	9A06903200	TAPPING SCREW, ST3.0X6	
38	9A06903300	TAPPING SCREW, ST3.0X8	
39	9A06903400	TAPPING SCREW, ST3.0X16	
40	9A06903700	TAPPING SCREW, ST3.0X12	
41	9A06903600	TAPPING SCREW, ST3.0X10	
42	9A06903500	TAPPING SCREW, ST3.0X8	
43	9A06903800	TAPPING SCREW, ST4.0X8	
44	9A06903900	MACHINE SCREW, M4X10	
45	9A06904000	PLAIN WASHER	
46	9A06904100	SPRING WASHER	
47	9A06904200	MACHINE NUT, M4	
48	9A07063100	POWER PCB ASSY	
49	△ 9A06899200	AC CORD, SPT-2 1830MM UL	
50	9A06900700	NAME PLATE	
51	9A06901600	H/P JACK HOLDER	
52	9A06901400	HEAT SINK (A)	
53	9A06901700	GND CONNECTOR	

4 PC BOARDS AND PARTS LIST

MAIN PCB ASSY

REF. NO.	PARTS NO.	DESCRIPTION
	9A07062900	MAIN PCB ASSY
	9A06885100	MAIN PCB
AC, GND, AC	9A06897300	LEAD PIN 3P
CF101, 102	9A06603900	CERAMIC FILTER, SFE-10.7M
CF103	9A06603800	CERAMIC FILTER, SFZ450G3L
C428, 429	△ 9A06891600	C, ELEC 63V 6800UF
D101, 102	9A06894600	DIODE, 1SV103B (1SV55)
D103, 104	9A06894700	DIODE, 1SV149B (KV1236)
D105	9A06602600	DIODE, IN4148
D106	9A06894500	ZENER DIODE, 5.6V 1/2W
D107-109	9A06602600	DIODE, IN4148
D406	9A06894800	RECTIFIER, IN4003
D407	9A06602600	DIODE, IN4148
D409, 410	9A06894400	ZENER DIODE, 12V 1W
D411	△ 9A06603500	DIODE, BRIDGE
FS401, 402	9A06896100	FUSE CLIP
FS401, 402	9A06896200	FUSE (SLOW), 5A/125V
IC101	9A06895000	IC, LA1186
IC102	9A06603700	IC, LA1805
IC201, 202	9A06533700	IC, JRC4558LS
IC301	9A06895100	IC, M4558DD
IC401	9A06533800	IC, STK4192/11
IC502	9A06536700	IC, TC9209N
JK301	9A06534200	RCA JACK, RCA603 6P
JK302	9A06534300	RCA JACK, RCA403 4P
JK401	9A06534100	SP JACK, WJ8-401A
L101	9A06895200	IFT, FM RF COIL XD06 BRN
L102	9A06895800	IFT, FM OSC COIL XD05
L104	9A06895600	IFT, AM ANT XD04 BLK
L105	9A06895700	IFT, AM OSC COIL XD01 RED
L106	9A06896000	P. COIL, 22UH AL0307
L401, 402	9A06895900	AUDIO COIL, 1UH XD08
Q101	9A06533300	TR, 2SC1675L
Q102	9A06533600	TR, 2SC1674K
Q103	9A06533400	TR, 2SK161GR
Q104, 105	9A06603600	TR, 2SA733P
Q106	9A06533300	TR, 2SC1675L
Q107-109	9A06894900	TR, 2SC945P
Q110, 111	9A06533300	TR, 2SC1675L
Q112-115	9A06894900	TR, 2SC945P
Q117, 118	9A06894900	TR, 2SC945P
Q404	△ 9A06533200	TR, 2SD880P/Q
Q405	△ 9A06533500	TR, 2SA834R
R409-412	△ 9A06889900	R, 1/2W 3.3K
R415, 416	△ 9A06889800	R, 1/2W 1.5K
R419, 420	△ 9A06890000	R, 1W 4.7
R421, 422	△ 9A06889600	R, 1/2W 10
R425	△ 9A06889900	R, 1/2W 3.3K
R432	△ 9A06890100	R, 5W 47 FMO
R433	△ 9A06890200	R, 2W 47 FMO

MAIN PCB ASSY

REF. NO.	PARTS NO.	DESCRIPTION
R434, 435	△ 9A06890300	R, 2W 1.5K
R438, 439	△ 9A06889700	R, 1/2W 330
SFR101	9A06603300	SFR, 10KX T
SFR102	9A06603400	SFR, 100KX T
TC101, 102	9A06603100	TRIMMER, 10P
TC103	9A06603200	TRIMMER, 20P
TM101	9A06896300	ANT JACK, WJ4-104A
TP7	9A06897400	LEAD PIN 1P
T101	9A06895300	IFT, FM IFT XD07 ORG
T102	9A06895500	IFT, AM IFT XD03 WHT
T103	9A06895400	IFT, FM DEF XD02 BLK

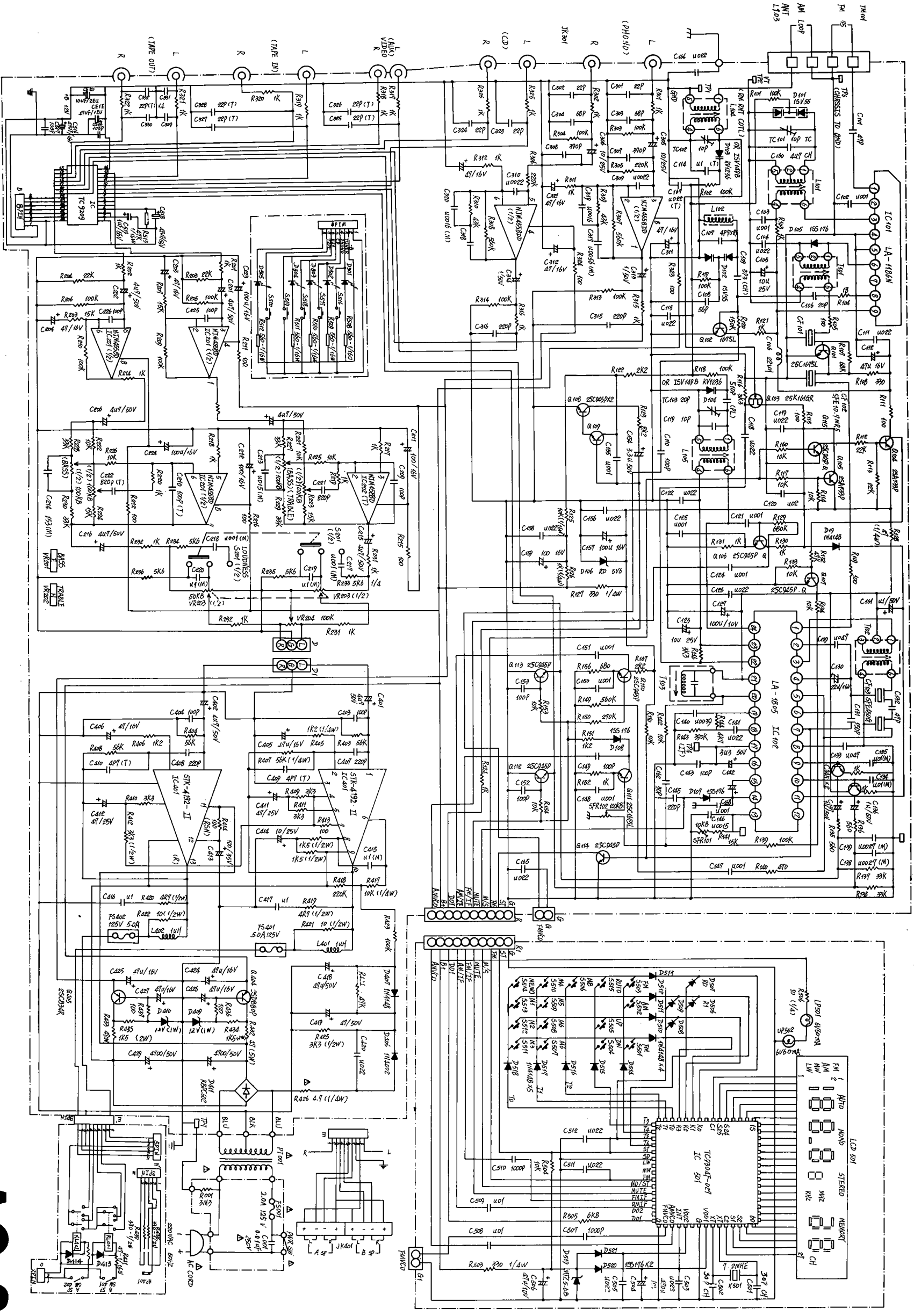

INSTRUCTIONS FOR SERVICE PERSONNEL
 BEFORE RETURNING APPLIANCE TO THE CUSTOMER, MAKE LEAKAGE-CURRENT OR RESISTANCE MEASUREMENTS TO DETERMINE THAT EXPOSED PARTS ARE ACCEPTABLY INSULATED FROM THE SUPPLY CIRCUIT.

NOTES:
 1. Resistor values are in ohms (K=kilo-ohms, M=megohms).
 2. Capacitor values are in microfarads (p=picofarads).
 3. Δ Parts marked with this sign are safety critical components. They must always be replaced with identical components—refer to the appropriate parts list and ensure exact replacement!

AG-360

AM/FM Stereo Receiver



MAIN PCB

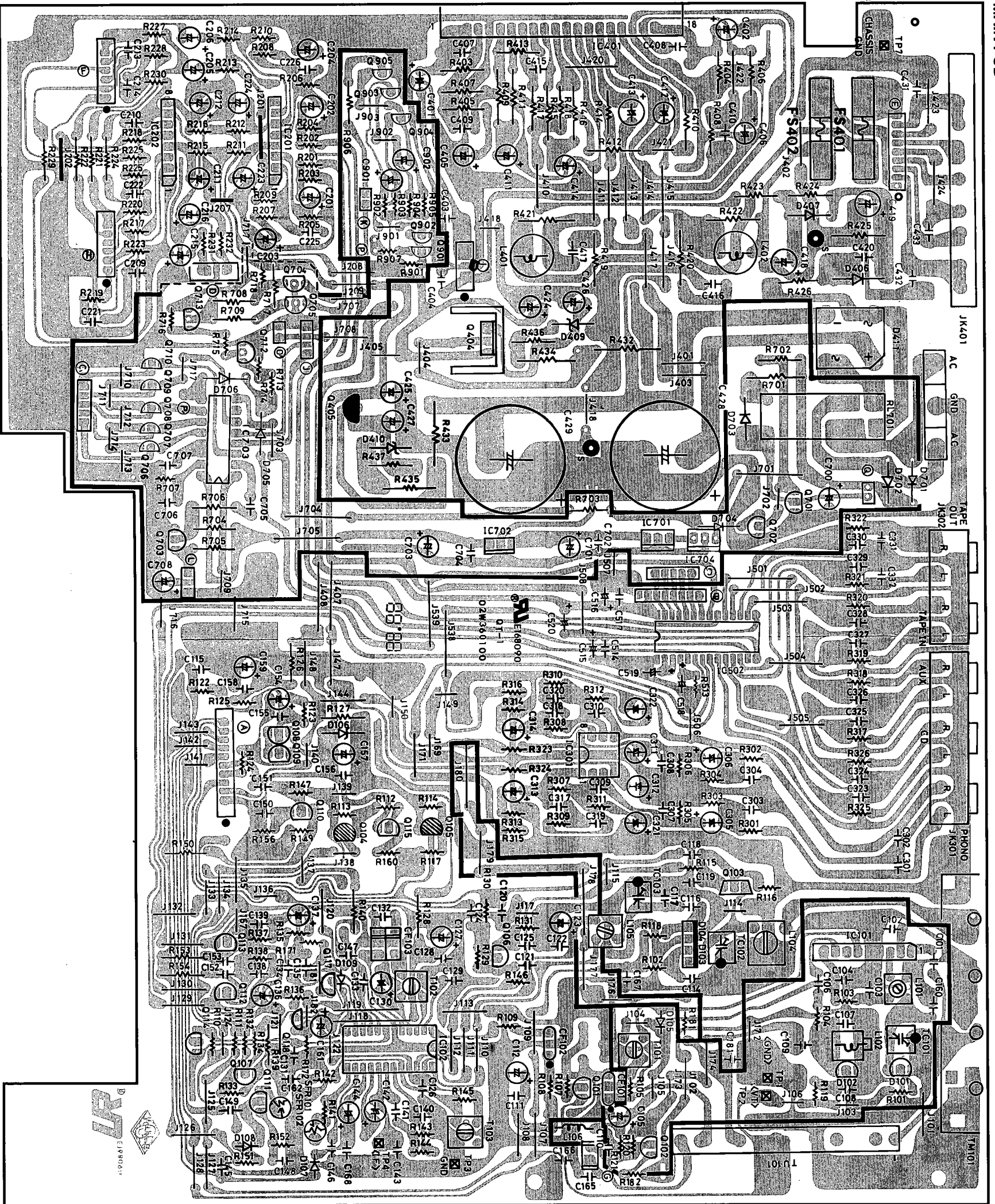

FRONT PCB

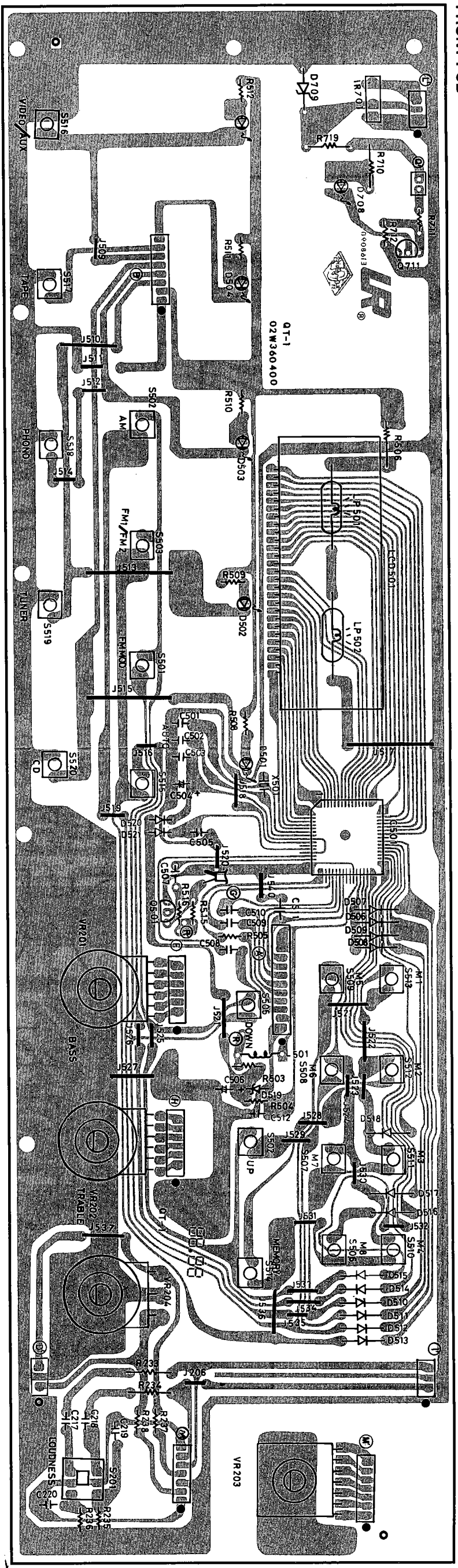

HEAD PHONE PCB

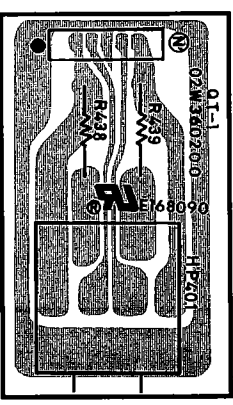

SP SELECTOR PCB

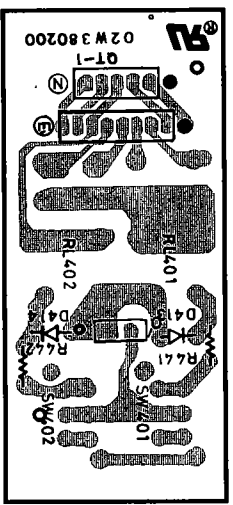

POWER PCB

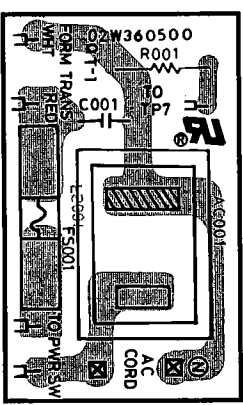

FRONT PCB ASSY

REF. NO.	PARTS NO.	DESCRIPTION
	9A07063000	FRONT PCB ASSY
	9A06885200	FRONT PCB
D501-505	9A06602700	LED, ORG
D506-518	9A06602600	DIODE, IN4148
D519	9A06894500	ZENER DIODE, 5.6V 1/2W
IC501	9A06534700	IC, TC9304F-027
LCD501	9A06534800	LCD DISPLAY, UTN-001ENV
LP501, 502	9A06534600	FUSE LAMP, 6V 60MA
L501	9A06898400	P. COIL, 10UH ALO307
S201	9A06604200	LOUDNESS SW, SPEA 8X8
S501-520	9A06602800	TACT SW, SKHVBL
VR201, 202	9A06534400	VR, 100KBX2
VR203	9A06604000	VR, 50KAX2
VR204	9A06534500	VR, 100KW
X501	9A06898500	X' TAL, 7.2MHZ

HEAD PHONE PCB ASSY

REF. NO.	PARTS NO.	DESCRIPTION
	9A07063200	HEAD PHONE PCB ASSY
	9A06885400	HEAD PHONE PCB
HP401	9A06535000	HEAD PHONE JACK, 6.35MM
R438, 439	△ 9A06899800	R, 1W 330

SPEAKER SELECTOR PCB ASSY

REF. NO.	PARTS NO.	DESCRIPTION
	9A07063300	SPEAKER SELECTOR PCB ASSY
	9A06885600	SP SELECTOR PCB
D413, 414	9A06602600	DIODE, IN4148
RL401, 402	9A06535100	RELAY, 941-2C-12D
SW401, 402	9A06603000	SP CHANGE SW

POWER PCB ASSY

REF. NO.	PARTS NO.	DESCRIPTION
	9A07063100	POWER PCB ASSY
	9A06885300	POWER PCB
	△ 9A06899200	AC CORD, SPT-2 1830MM UL
	△ 9A06602800	POWER SWITCH
AC001	△ 9A06602900	AC SOCKET, S-16519-02
C001	△ 9A06899700	C, POLY 0.01UF/250V
FS001	9A06896100	FUSE CLIP
FS001	△ 9A06534900	FUSE (SLOW), 2A/125V UL
PT001	△ 9A06625900	POWER TRANS, 117V
R001	△ 9A06899400	R, 1/2W 3.3M

INCLUDED ACCESSORIES

REF. NO.	PARTS NO.	DESCRIPTION
	9A06668100	OWNER'S MANUAL (E/F)
	9A06902500	FM ANT
	9A06902600	AM ANT

30

AG-360

TEAC

TEAC CORPORATION	3-7-3, Nakacho, Musashino-shi, Tokyo 180-8550, Japan	Phone: (0422) 52-5081
TEAC AMERICA, INC.	7733 Telegraph Road, Montebello, California 90640	Phone: (213) 726-0303
TEAC CANADA LTD.	5939 Wallace Street, Mississauga, Ontario L4Z 1Z8, Canada	Phone: 905-890-8008
TEAC MEXICO, S.A. De C.V	Privada De Corina, No.18, Colonia Del Carrmen Coyoacan, Mexico DF 04100	Phone: 5-658-1943
TEAC UK LIMITED	5 Marlin House, Marlins Meadow, The Croxley Centre, Watford, Herts. WD1 8YA, U.K.	Phone: 01923-819699
TEAC DEUTSCHLAND GmbH	Bahnstrasse 12, 65205 Wiesbaden-Erbenheim, Germany	Phone: 0611-71580
TEAC FRANCE S. A.	17 Rue Alexis-de-Tocqueville, CE 005 92182 Antony Cedex, France	Phone: 01.42.37.01.02
TEAC BELGIUM NV/SA	P.A. TEAC Nederland BV, Perkinsbaan 11a, 3439 ND Nieuwegein, Netherlands	Phone: 0031-30-6048115
TEAC NEDERLAND BV	Perkinsbaan 11a, 3439 ND Nieuwegein, Netherlands	Phone: 030-6030229
TEAC AUSTRALIA PTY., LTD. A.C.N. 005 408 462	106 Bay Street, Port Melbourne, Victoria 3207, Australia	Phone: (03) 9644-2442
TEAC ITALIANA S.p.A.	Via C. Cantù 11, 20092 Cinisello Balsamo, Milano, Italy	Phone: 02-66010500