

# TEAC<sup>®</sup> AG<sup>1</sup> 3000.6000.7000 SERIES

AM-FM STEREO RECEIVER  
**SERVICE MANUAL**

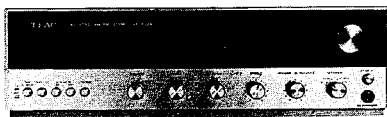

AG 3000

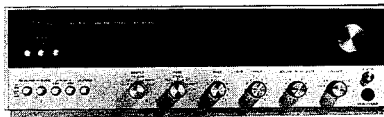

AG 6000



AG 7000

---

## TEAC CORPORATION

SALES OFFICE: SHINJUKU BUILDING  
1-8-1, NISHI-SHINJUKU, SHINJUKU, TOKYO

U.S. DISTRIBUTOR: TEAC CORPORATION OF AMERICA  
7733 TELEGRAPH ROAD  
MONTEBELLO, CALIFORNIA 90640  
U.S.A.  
EUROPEAN DISTRIBUTOR: TEAC EUROPE N.V.  
KABELWEG 45-47, AMSTERDAM-W. 2,  
HOLLAND

---

## SPECIFICATIONS

SPECIFICATION FOR AG 7000

### AMPLIFIER SECTION

#### Power Output:

Music Power(IHF): 240W $\pm$ 0.5 dB at 4 ohms  
185W $\pm$ 0.5 dB at 8 ohms

#### Continuous Power(Each Channel)

80W/80W $\pm$ 0.5 dB at 4 ohms  
65W/65W $\pm$ 0.5 dB at 8 ohms

#### Harmonic Distortion:

Less than 0.5%

#### Power Bandwidth(IHF):

10 to 35,000 Hz at 8 ohms

#### Frequency Response

#### (at Normal Listening Level):

20 to 30,000 Hz $\pm$ 1 dB

#### Input Sensitivity

#### (for Rated Output):

Phono: 2mV $\pm$ 2 dB

Aux: 150mV $\pm$ 2 dB

Tape Monitor(Pin Jack): 150mV $\pm$ 2 dB

Tape Monitor(Din): 150mV $\pm$ 2 dB

#### Recording Output

Pin Jack: 150mV $\pm$ 2 dB;  
0.15V at 2mV for Phono.  
1V at 1mV for FM,  
100% modulation.  
0.15V at 5mV/m for AM,  
30% modulation.

Din: 40mV $\pm$ 2 dB

#### Hum and Noise(Below Rated Output)

Volume Minimum: 80 dB

Phono: 65 dB

Aux: 70 dB

#### Channel Separation(at Rated Output)

Phono: 50 dB

Aux: 50 dB

#### Output Load Impedance:

4 to 16 ohms

#### Damping Factor:

80 at 8 ohms

#### Equalizer

Phono: RIAA, NFB type

#### Controls and Switches:

Bass Control:  $\pm$ 15 dB at 50 Hz

Treble Control:  $\pm$ 11 dB at 10,000 Hz

Loudness Control: +10 dB at 50 Hz,  
+4 dB at 10,000 Hz

(volume control at -30 dB)

Low Filter: 100 Hz 6 dB/oct

High Filter: 5,000 Hz 12 dB/oct

Mode Switch: Rev, Stereo, Left, Right, L+R

Source Switch: 1.AM, 2.FM, 3.FM Auto,  
4.Phono, 5.Aux

Speaker Switch: 1.OFF, 2.A, 3.B, 4.C, 5.A B,  
6.A C

Tape Monitor Switch: 1.Source, 2.Tape-1, 3.Tape-2

Rec Mode Switch: 1.NORMAL, 2.Copy-1, 3.Copy-2

TUNER SECTION:

FM

Tuning Range:	88 to 108 MHz
Sensitivity:	1.2uV $\pm$ 3 dB (20 dB quieting)
	1.7uV $\pm$ 3 dB (IHF)
Harmonic Distortion:	Less than 0.3%
Signal to Noise Ratio:	Better than 70 dB
Selectivity:	Better than 70 dB
Capture Ratio:	Less than 1 dB
Image Frequency Rejection:	Better than 100 dB
IF Rejection:	Better than 100 dB
FM Stereo Separation:	Better than 40 dB
Spurious Response Rejection:	Better than 100 dB
Spurious Radiation:	9 dB
Antenna Input Impedance:	300 ohms, balanced
	75 ohms, unbalanced

AM

Tuning Range:	535 to 1,605 kHz
Sensitivity (IHF):	10uV $\pm$ 3 dB at 1 MHz
Image Frequency Rejection:	Better than 50 dB
IF Frequency Rejection:	Better than 80 dB
Selectivity:	Better than 25 dB
Power Requirements:	100, 117, 220, 240V AC;
	50/60 Hz
Power Consumption:	440W max.
Dimensions and Weight:	16-1/4" (W) x 4-3/4" (H) x 14" (D):
	25.3 lbs, net

ACCESSORIES

FM Ribbon Antenna, Pin plug, Shorting pin plug,  
Polishing cloth

- Features and Specifications are subject to change without notice.
-

SPECIFICATIONS FOR AG 6000

---

AMPLIFIER SECTION

Power Output:

Music Power(IHF): 180W $\pm$ 0.5 dB at 4 ohms  
 160W $\pm$ 0.5 dB at 8 ohms

Continuous Power(Each Channel):

60W/60W $\pm$ 0.5 dB at 4 ohms  
 50W/50W $\pm$ 0.5 dB at 8 ohms

Harmonic Distortion:

Less than 0.5%

Power Bandwidth(IHF):

10 to 35,000 Hz at 8 ohms

Frequency Response

(at Normal Listening Level):

20 to 30,000 Hz  $\pm$ 1 dB

Input Sensitivity

(for Rated Output):

Phono: 2mV  $\pm$  2 dB  
 Aux: 150mV  $\pm$  2 dB  
 Tape Monitor(Pin Jack): 150mV  $\pm$  2 dB  
 Tape Monitor(Din): 150mV  $\pm$  2 dB

Recording Output

Pin Jack:

150mV  $\pm$  2 dB;  
 0.15V at 2mV for Phono.  
 1V at 1mV for FM,  
 100% modulation.  
 0.15V at 5mV/m for AM,  
 30% modulation.

Din:

40mV  $\pm$  2 dB

Hum and Noise(Below Rated Output)

Volume Minimum: 80 dB  
 Phono: 65 dB  
 Aux: 70 dB

Channel Separation(at Rated Output)

Phono: 50 dB  
 Aux: 50 dB

Output Load Impedance:

4 to 16 ohms

Damping Factor:

80 at 8 ohms

Equalizer

Phono: RIAA, NFB type

Controls and Switches:

Bass Control:  $\pm$ 15 dB at 50 Hz  
 Treble Control:  $\pm$ 11 dB at 10,000 Hz  
 Loudness Control: +10 dB at 50 Hz,  
 +4 dB at 10,000 Hz  
 (volume control at -30 dB)

Low Filter:

100 Hz 6 dB/oct

High Filter:

5,000 Hz 12 dB/oct

Mode Switch:

Rev, Stereo, Left, Right, L+R

Source Switch:

1.AM, 2.FM, 3.FM Auto,  
 4.Phono, 5.Aux

Speaker Switch:

1.OFF, 2.A, 3.B, 4.C, 5.A B,  
 6.A C.

Tape Monitor Switch:

1.Source, 2.Tape-1, 3.Tape-2

## TUNER SECTION:

## FM

Tuning Range:	88 to 108 MHz
Sensitivity:	1.4uV $\pm$ 3 dB (20 dB quieting) 1.8uV $\pm$ 3 dB (IHF)
Harmonic Distortion:	Less than 0.5%
Signal to Noise Ratio:	Better than 70 dB
Selectivity:	Better than 60 dB
Capture Ratio:	Less than 1 dB
Image Frequency Rejection:	Better than 90 dB
IF Rejection:	Better than 90 dB
FM Stereo Separation:	Better than 38 dB
Spurious Response Rejection:	Better than 95 dB
Spurious Radiation:	15 dB
Antenna Input Impedance:	300 ohms, balanced 75 ohms, unbalanced

## AM

Tuning Range:	535 to 1,605 kHz
Sensitivity (IHF):	10uV $\pm$ 3 dB at 1 MHz
Image Frequency Rejection:	Better than 50 dB
IF Frequency Rejection:	Better than 80 dB
Selectivity:	Better than 25 dB
Power Requirements:	100, 117, 220, 240V AC: 50/60 Hz
Power Consumption:	330W max.
Dimensions and Weight:	16-1/4"(W) x 4-3/4"(H) x 14"(D): 24.2 lbs, net

## ACCESSORIES

FM Ribbon Antenna, Pin plug, Shorting pin plug,  
Polishing cloth

- Features and Specifications are subject to change without notice.

SPECIFICATION FOR AG 3000

---

AMPLIFIER SECTION

Power Output:  
 Music Power(IHF): 110W $\pm$ 0.5 dB at 4 ohms  
 90W $\pm$ 0.5 dB at 8 ohms

Continuous Power  
 (Each Channel): 40W/40W 0.5 dB at 4 ohms  
 36W/36W 0.5 dB at 8 ohms

Harmonic Distortion: Less than 0.8%

Power Bandwidth(IHF): 10 to 30,000 Hz

Frequency Response  
 (at Normal Listening Level): 20 to 30,000 Hz $\pm$ 1 dB

Input Sensitivity  
 (For Rated Output):

Phono: 2mV $\pm$  2 dB

Aux: 150mV $\pm$  2 dB

Tape Monitor(PinJack): 150mV $\pm$  2 dB

Tape Monitor(Din): 150mV $\pm$  2 dB

Recording Output:  
 Pin Jack: 150mV $\pm$  2 dB; 0.15V at 2mV  
 Phono input  
 1V at 1mV input for FM,  
 100% modulation  
 0.15V at 5mV/m input for  
 AM, 30% modulation

Din: 40mV $\pm$  2 dB

Hum and Noise  
 (Below Rated Output):

Volume Minimum: 80 dB

Phono: 6.5 dB

Aux: 70 dB

Channel Separation  
 (at Rated Output):

Phono: 50 dB

Aux: 50 dB

Output Load Impedance: 4 to 16 ohms

Damping Factor: 80 at 8 ohms

Equalizer:

Phono: RIAA, NFB type

Controls and Switches

Bass Control:  $\pm$ 15 dB at 50 Hz

Treble Control:  $\pm$ 11 dB at 10,000 Hz

Loudness Control: +10 dB at 50 Hz,  
 +4 dB at 10,000 Hz  
 (volume control at -30dB)

Low Filter: 100 Hz 6 dB/oct

High Filter: 5,000 Hz 12 dB/oct

Mode Switch: REV, STEREO, LEFT, RIGHT, L+R

Source Switch: 1.AM, 2.FM, 3.FM AUTO,  
 4.PHONO, 5.AUX

Speaker Switch: 1.OFF, 2.MAIN, 3.REMOTE,  
 4.M+R

Tape Monitor Switch: On, Off

TUNER SECTION:

FM:

Tuning Range: 88 to 108 MHz  
Sensitivity: 1.4uV  $\pm$  3 dB(20 dB quieting)  
1.8uV  $\pm$  3 dB(IHF)  
Harmonic Distortion: Less than 0.8%  
Signal to Noise Ratio: Better than 70 dB  
Selectivity: Better than 50 dB  
Capture Ratio: Less than 2.5 dB  
Image Frequency Rejection: Better than 80 dB  
IF Rejection: Better than 95 dB  
FM Stereo Separation: Better than 38 dB  
Spurious Response Rejection: Better than 90 dB  
Spurious Radiation: 15 dB  
Antenna Input Impedance: 300 ohms, balanced  
75 ohms, unbalanced

AM:

Tuning Range: 535 to 1,605 kHz  
Sensitivity(IHF): 10uV  $\pm$  3 dB at 1 MHz  
Image Frequency Rejection: Better than 50 dB  
IF Frequency Rejection: Better than 80 dB  
Selectivity: Better than 25 dB  
Power Requirements: 100, 117, 220, 240V AC:  
50/60 Hz  
Power Consumption: 200W Max.  
Dimensions and Weight: 16-1/4"(W) x 4-3/4"(H) x 14"(D);  
22.2 lbs net

ACCESSORIES

FM Ribbon Antenna

- Features and Specifications subject to change without notice
-

# ALIGNMENT PROCEDURE

## GENERAL NOTICE

Overall adjustment and alignment procedures are outlined below.

The AG series Receivers utilize the latest circuitry and most modern materials and techniques.

Since the AG series Receivers are similar in design to those of other leading manufacturers, general alignment and servicing procedures may be followed. However, if you do not possess the required test equipment or should you fail to understand the circuit operation, alignment should not be attempted.

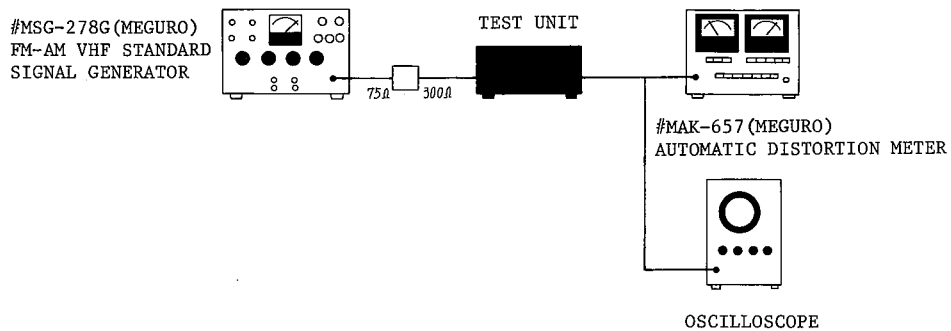

SET UP FOR STEP 1 - 7

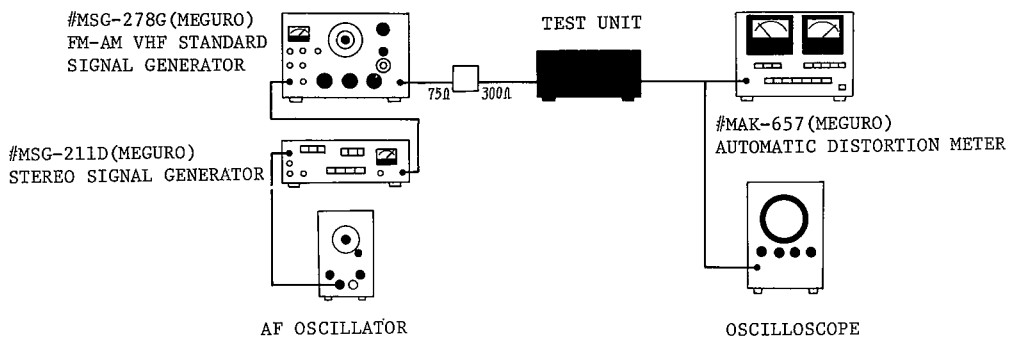

SET UP FOR STEP 1 - 5

### NOTE

Trap adjustments for 67 kHz and 71 kHz may be accomplished without the stereo signal oscillator shown in chart #2.



FM ALIGNMENT PROCEDURE -AG 7000-

STEP	TEST SIGNAL	APPLY TO	CHECK POINT	DIAL POINTER	ADJUST	LEVEL METER READING
1. Tracking Alignment	Set FM-SSG freq. to 90 MHz, 10 - 30 dB output, 75 kHz deviation with 1 kHz.  Set FM-SSG freq. to 106 MHz, 10 - 30 dB output, 75 kHz deviation with 1 kHz.	ANTENNA FM 300 ohm terminal  ANTENNA FM 300 ohm terminal	any jacks  RECORD any jacks	90 MHz  106 MHz	L-105 (local osc)  TC-105 (local osc)	maximum  maximum
2. Repeat above step 1 and step 2 until accurate dial pointer, and adjust L-106(top & bottom) for maximum reading on level meter.						
3. Adjust Discriminator	Set FM-SSG freq. to 98 MHz, 60 dB output, 75 kHz deviation with 1 kHz.	ANTENNA FM 300 ohm terminal	RECORD any jacks	98 MHz	T-201(FM DET.) Top & bottom. Preset VR-201 at mid position and adjust top core of T-201 so the needle is in the center of the TUNING meter when FM-SSG output is reduced to zero(no signal). After top of T-201 is adjusted reset FM-SSG to 98 MHz, 60 dB output, 75 kHz deviation. Adjust bottom core of T-201 for minimum distortion.	
4. Adjust IF Transformer	Set FM-SSG freq. to 98 MHz, 20 - 30 dB output with no modulation.	ANTENNA FM 300 ohm terminal	Connect DC VTVM to terminal No.4 on IF PC board.	98 MHz	T-202	maximum
5. Adjust muting	Set FM-SSG freq. to 98 MHz, 25 dB output, 75 kHz deviation with 1 kHz.	ANTENNA FM 300 ohm terminal	RECORD any jacks	98 MHz	VR-202	MUTING circuit should case operation when reduce FM-SSG output is reduced to 25 dB.

CONTINUED

FM STEREO (MPX) ADJUSTMENT

STEP	TEST SIGNAL	APPLY TO	CHECK POINT	DIAL POINTER	ADJUST	LEVEL METER READING
1. Adjust 71, 67 kHz trap coil	Set FM-SSG freq. to 98 MHz, 60 dB output 75 kHz deviation, and AF oscillator set for 67 kHz or 71 kHz to the external modulation input of FM-SSG.	ANTENNA FM 300 ohm terminal	RECORD any jacks	98 MHz	L-301 - 2	minimum
2. Adjust 19 kHz coil 19 kHz coil	Set FM-SSG freq. to 98 MHz, 60 dB output, with composite MPX signal 1 kHz on left chan.	ANTENNA FM 300 ohm terminal	RECORD left channel	98 MHz 98 MHz	L-303 L-304	maximum
3. Adjust 38 kHz coil	Set FM-SSG freq. to 98 MHz, 60 dB output, with composite MPX signal 1 kHz on left chan.	ANTENNA FM 300 ohm terminal	RECORD left channel	98 MHz	L-305	maximum
4. Adjust Distortion	Set FM-SSG freq. to 98 MHz, 60 dB output, with composite MPX signal 1 kHz on left chan.	ANTENNA FM 300 ohm terminal	RECORD left channel	98 MHz	T-301 (T-302) (T-303)	minimum distortion
5. Adjust Separation	Set FM-SSG freq. to 98 MHz, 60 dB output, with composite MPX signal 1 kHz on left or right channel.	ANTENNA FM 300 ohm terminal	RECORD right or left channel	98 MHz	VR-301	maximum separation
6. Adjust Stereo Auto	Set FM-SSG freq. to 98 MHz, 20 dB output, with composite MPX signal 1 kHz.	ANTENNA FM 300 ohm terminal	RECORD any jacks	98 MHz	VR-203	Stereo indicator lamp should light when FM-SSG output is at 20 dB or higher.

FM ALIGNMENT PROCEDURE -AG 6000 EARLY MODEL-

STEP	TEST SIGNAL	APPLY TO	CHECK POINT	DIAL POINTER	ADJUST	LEVEL METER READING
1. Tracking Alignment	Set FM-SSG freq. to 90 MHz, 10 - 30 dB output, 75 kHz deviation with 1 kHz.  Set FM-SSG freq. to 106 MHz, 10 - 30 dB output, 75 kHz deviation with 1 kHz.	ANTENNA FM 300 ohm terminal	any jacks	90 MHz	L-105 (Local osc) L-101 - 103 (RF)	maximum (1 kHz)
		ANTENNA FM 300 ohm terminal	RECORD any jacks	106 MHz	TC-104 (Local osc) TC-101 - 103 (RF)	maximum
2. Repeat above step 1 and step 2 until accurate dial pointer, and adjust L-106(top & bottom) for maximum reading on level meter.						
3. Adjust IF Transformer	Set FM-SSG freq. to 98 MHz, 20 - 30 dB output, 75 kHz deviation with 1 kHz.	ANTENNA FM 300 ohm terminal	RECORD any jacks	98 MHz	T-204	maximum reading on INPUT meter. T-201 - 202 are factory adjusted, do not readjust.
4. Adjust Discriminator	Set FM-SSG freq. to 98 MHz, 60 dB output, 75 kHz deviation with 1 kHz.	ANTENNA FM 300 ohm terminal	RECORD any jacks	98 MHz	T-203(FM DET.) Top & bottom. First adjust top & bottom core of T-203 for maximum reading(gain) on level meter then readjust top core of T-203 so the needle is in the center of tuning meter when FM-SSG output is reduced to zero. After top core of T-203 is adjusted, reset FM-SSG to 60 dB. Readjust T-203 bottom core for minimum distortion at record jacks.	
5. Adjust muting	Set FM-SSG freq. to 98 MHz, 25 dB output, 75 kHz deviation with 1 kHz.	ANTENNA FM 300 ohm terminal	RECORD any jacks	98 MHz	VR-201	MUTING circuit should case operation when reduce FM-SSG output is reduced to 20 dB.

CONTINUED

FM STEREO (MPX) ADJUSTMENT

STEP	TEST SIGNAL	APPLY TO	CHECK POINT	DIAL POINTER	ADJUST	LEVEL METER READING
1. Adjust 71, 67 kHz trap coil	Set FM-SSG freq. to 98 MHz, 60 dB output 75 kHz deviation, and AF oscillator set for 67 kHz or 71 kHz to the external modulation input of FM-SSG.	ANTENNA FM 300 ohm terminal	RECORD any jacks	98 MHz	L-301 - 302	minimum
2. Adjust 19 kHz coil 19 kHz coil	Set FM-SSG freq. to 98 MHz, 60 dB output, with composite MPX signal 1 kHz on left chan.	ANTENNA FM 300 ohm terminal	RECORD left channel	98 MHz 98 MHz	L-301 L-302	maximum
3. Adjust 38 kHz coil	Set FM-SSG freq. to 98 MHz, 60 dB output, with composite MPX signal 1 kHz on left chan.	ANTENNA FM 300 ohm terminal	RECORD left channel	98 MHz	L-303	maximum
4. Adjust Distortion	Set FM-SSG freq. to 98 MHz, 60 dB output, with composite MPX signal 1 kHz on left chan.	ANTENNA FM 300 ohm terminal	RECORD left channel	98 MHz	T-301 (T-302) (T-303)	minimum distortion
5. Adjust Separation	Set FM-SSG freq. to 98 MHz, 60 dB output, with composite MPX signal 1 kHz on left or right channel.	ANTENNA FM 300 ohm terminal	RECORD right or left channel	98 MHz	VR-001	maximum separation

FM ALIGNMENT PROCEDURE -AG 6000 LATE MODEL-

STEP	TEST SIGNAL	APPLY TO	CHECK POINT	DIAL POINTER	ADJUST	LEVEL METER READING
1. Tracking Alignment	Set FM-SSG freq. to 90 MHz, 10 - 30 dB output, 75 kHz deviation with 1 kHz.	ANTENNA FM 300 ohm terminal	any jacks	90 MHz	L-105 (Local osc) L-101 - 103 (RF)	maximum (1 kHz)
	Set FM-SSG freq. to 106 MHz, 10 - 30 dB output, 75 kHz deviation with 1 kHz.	ANTENNA FM 300 ohm terminal	RECORD any jacks	106 MHz	TC-104 (Local osc) TC-101 - 103 (RF)	maximum
2. Repeat above step 1 and step 2 until accurate dial pointer, and adjust L-106(top & bottom) for maximum reading on level meter.						
3. Adjust IF Transformer	Set FM-SSG freq. to 98 MHz, 20 - 30 dB output, 75 kHz deviation with 1 kHz.	ANTENNA FM 300 ohm terminal	RECORD any jacks	98 MHz	T-204	maximum reading on INPUT meter. T-201 - 202 are factory adjusted, do not readjust.
4. Adjust IF Transformer	Set FM-SSG freq. to 98 MHz, 20 - 30 dB output with no modulation.	ANTENNA FM 300 ohm terminal	Connect DC VTVM to terminal No.4 on IF PC board.	98 MHz	T-202	maximum
5. Adjust muting	Set FM-SSG freq. to 98 MHz, 25 dB output, 75 kHz deviation with 1 kHz.	ANTENNA FM 300 ohm terminal	RECORD any jacks	98 MHz	VR-202	MUTING circuit should case operation when reduce FM-SSG output is reduced to 25 dB.

CONTINUED

FM STEREO (MPX) ADJUSTMENT

STEP	TEST SIGNAL	APPLY TO	CHECK POINT	DIAL POINTER	ADJUST	LEVEL METER READING
1. Adjust 71, 67 kHz trap coil	Set FM-SSG freq. to 98 MHz, 60 dB output 75 kHz deviation, and AF oscillator set for 67 kHz or 71 kHz to the external modulation input of FM-SSG.	ANTENNA FM 300 ohm terminal	RECORD any jacks	98 MHz	L-301 - 302	minimum
2. Adjust 19 kHz coil 19 kHz coil	Set FM-SSG freq. to 98 MHz, 60 dB output, with composite MPX signal 1 kHz on left chan.	ANTENNA FM 300 ohm terminal	RECORD left channel	98 MHz 98 MHz	L-303 L-304	maximum
3. Adjust 38 kHz coil	Set FM-SSG freq. to 98 MHz, 60 dB output, with composite MPX signal 1 kHz on left chan.	ANTENNA FM 300 ohm terminal	RECORD left channel	98 MHz	L-305	maximum
4. Adjust Distortion	Set FM-SSG freq. to 98 MHz, 60 dB output, with composite MPX signal 1 kHz on left chan.	ANTENNA FM 300 ohm terminal	RECORD left channel	98 MHz	T-301 (T-302) (T-303)	minimum distortion
5. Adjust Separation	Set FM-SSG freq. to 98 MHz, 60 dB output, with composite MPX signal 1 kHz on left or right channel.	ANTENNA FM 300 ohm terminal	RECORD right or left channel	98 MHz	VR-301	maximum separation
6. Adjust Stereo Auto	Set FM-SSG freq. to 98 MHz, 20 dB output, with composite MPX signal 1 kHz.	ANTENNA FM 300 ohm terminal	RECORD any jacks	98 MHz	VR-203	Stereo indicator lamp should light when FM-SSG output is at 20 dB or higher.

FM ALIGNMENT PROCEDURE -AG 3000-

STEP	TEST SIGNAL	APPLY TO	CHECK POINT	DIAL POINTER	ADJUST	LEVEL METER READING
1. Tracking Alignment	Set FM-SSG freq. to 90 MHz, 10 - 30 dB output, 75 kHz deviation with 1 kHz.	ANTENNA FM 300 ohm terminal	any jacks	90 MHz	L-105 (local osc) L-101 - 103 (RF)	maximum
	Set FM-SSG freq. to 106 MHz, 10 - 30 dB output, 75 kHz deviation with 1 kHz.	ANTENNA FM 300 ohm terminal	RECORD any jacks	106 MHz	TC-104 (local osc) TC-101 - 103	maximum
2. Repeat above step 1 and step 2 until accurate dial pointer, and adjust L-106(top & bottom) for maximum reading on level meter.						
3. Adjust IF Transformer	Set FM-SSG freq. to 98 MHz, 20 - 30 dB output, 75 kHz deviation with 1 kHz.	ANTENNA FM 300 ohm terminal	RECORD any jacks	98 MHz	T-201 T-202 T-205	maximum Maximum reading on INPUT meter.
4. Adjust Discriminator	Set FM-SSG freq. to 98 MHz, 60 dB output, 75 kHz deviation with 1 kHz.	ANTENNA FM 300 ohm terminal	RECORD any jacks	98 MHz	T-204(FM DET.) First adjust top and bottom cores of T-204 for maximum reading, then readjust for minimum distortion with maximum gain.	Top & bottom.
5. Adjust muting	Set FM-SSG freq. to 98 MHz, 20 dB output, 75 kHz deviation with 1 kHz.	ANTENNA FM 300 ohm terminal	RECORD any jacks	98 MHz	VR-201	MUTING circuit should case operation when reduce FM-SSG output is reduced to 20 dB.

CONTINUED

FM STEREO (MPX) ADJUSTMENT

STEP	TEST SIGNAL	APPLY TO	CHECK POINT	DIAL POINTER	ADJUST	LEVEL METER READING
1. Adjust 71, 67 kHz trap coil	Set FM-SSG freq. to 98 MHz, 60 dB output 75 kHz deviation, and AF oscillator set for 67 kHz or 71 kHz to the external modulation input of FM-SSG.	ANTENNA FM 300 ohm terminal	RECORD any jacks	98 MHz	L-301 - .302	minimum
2. Adjust 19 kHz coil	Set FM-SSG freq. to 98 MHz, 60 dB output, with composite MPX signal 1 kHz on left chan.	ANTENNA FM 300 ohm terminal	RECORD left channel	98 MHz	L-301	maximum
3. Adjust 38 kHz coil	Set FM-SSG freq. to 98 MHz, 60 dB output, with composite MPX signal 1 kHz on left chan.	ANTENNA FM 300 ohm terminal	RECORD left channel	98 MHz	L-302	maximum
4. Adjust Distortion	Set FM-SSG freq. to 98 MHz, 60 dB output, with composite MPX signal 1 kHz on left chan.	ANTENNA FM 300 ohm terminal	RECORD left channel	98 MHz	L-303	maximum
5. Adjust Separation	Set FM-SSG freq. to 98 MHz, 60 dB output, with composite MPX signal 1 kHz on left or right channel.	ANTENNA FM 300 ohm terminal	RECORD right or left channel.	98 MHz	T-301 (T-302) (T-303) VR-001	minimum distortion maximum separation



# AM ALIGNMENT PROCEDURE -AG 3000, AG 6000, AG 7000-

AM alignment procedures are identical for all AG series receivers.

STEP	TEST SIGNAL	APPLY TO	CHECK POINT	DIAL POINTER	ADJUST	LEVEL METER READING
1.	AM IF alignment Set AM-SSG freq. 1000 kHz, maximum output 30% modulation with 400 Hz.	Bar antenna	RECORD any jacks	600 kHz	T-401 - 3 (Top & bottom)	maximum
2.	Tracking Alignment Set AM-SSG freq. 600 kHz, 70 - 90 dB output, 30% modulation with 400 Hz.	Bar antenna (See figure)	RECORD any jacks	600 kHz	L-401 - 2 (Bar ant.)	maximum
3.	Set AM-SSG freq. 1400 kHz, 70 - 90 dB output, 30% modulation with 400 Hz.	Bar antenna	RECORD any jacks	1400 kHz	TC-301 - 3	maximum
4. Repeat above steps until accurate tuning dial pointer.						
5.	INPUT Meter Calibration Set AM-SSG freq. 1000 Hz, 76 dB output, 50% modulation with 400 Hz.	Bar antenna	observed INPUT meter	1000 kHz	VR-402	INPUT meter should read 1/2 position.
6.	Adjust AF output Level Set AM-SSG freq. 1000 kHz, 76 dB output, 50% modulation with 400 Hz.	Bar antenna		1000 kHz	VR-401	0.3 V

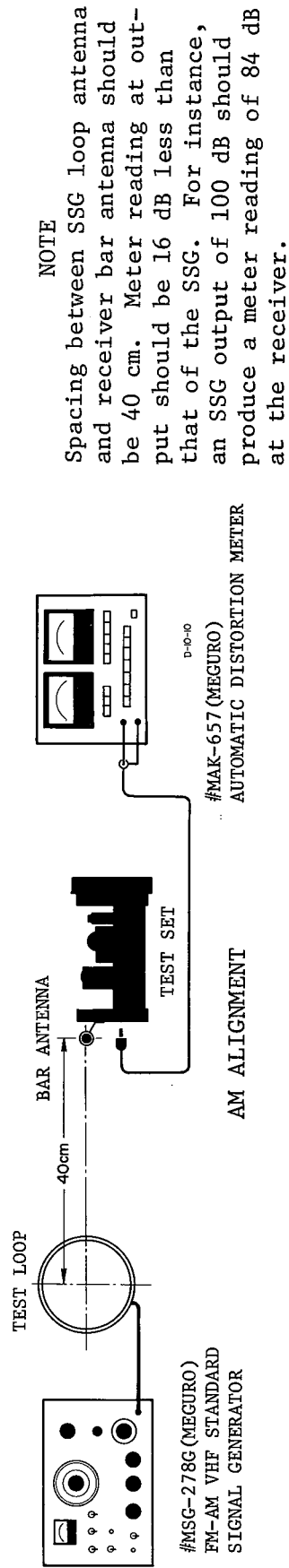

#MAK-657 (MEGURO) AUTOMATIC DISTORTION METER

#MSG-278G (MEGURO) FM-AM VHF STANDARD SIGNAL GENERATOR

# **TROUBLESHOOTING**

## **IMPORTANT**

Make certain that the following points have been satisfied before commencing troubleshooting operations.

1. The equipment is being properly operated in accordance with the information provided in the operation manual.
2. The equipment has been properly adjusted for maximum performance. Poor adjustment may result in failure to produce a precise stereo effect.
3. All connections are correct and secure.
4. There is no undue interference from other audio equipment, and the antenna has been properly connected or installed.

TROUBLESHOOTING AG 7000

Poor FM sensitivity  
Low INPUT meter indication

When the antenna terminal voltage is approximately 25 dB the normal meter deflection will be about mid scale.

Low sensitivity may be caused by faulty soldering of antenna terminal or a malfunction of the IF circuitry transistors (except IC), or FM RF amplifier.

If AGC voltage is -0.5V (with normal antenna terminal voltage of approx 60 dB) problem area is limited to Q-201, Q-203 of the IF circuitry, and their peripheral circuitry.

Poor FM sensitivity  
Normal INPUT meter indication

Q-206 IC or associated circuitry is malfunctioning. Replace IC or repair associated circuitry.

No output  
INPUT and TUNING meter indications are normal.

Defective Q-301, Q-302 or Q-303 in multiplex circuit.

High sound range is abnormal (FM)

De emphasis circuit is improperly set for receiving frequency of the area.

De Emphasis characteristic is 50 micro/sec for Japan and Europe, 75 micro/sec for USA.

To convert the de emphasis circuit from 75 micro/sec to 50 micro/sec, change C-319 and C-320 (390 pF) to 200 pF.

To convert from 50 micro/sec to 75 micro/sec reverse the above procedures.

Poor AM sensitivity

Damaged or faulty Q-401.

Replace Q-401(2SK-19BL). If replacement is required add an external 10 ohm resistor in series to the drain.

Loud hum or buzz in AM reception

May be caused by strong AM field intensity, flourescent lamps, or associated audio equipment.

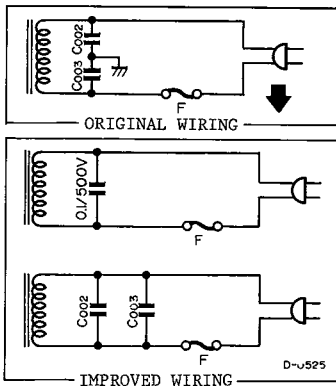

If hum occurs remove filter capacitors C-002 and C-003(1500pF) from chassis ground, connect them in parallel across power transformer primary winding, or remove C-002 and C-003 and connect a 0.01uF/500V capacitor across the power transformer primary winding.  
See connection below.

No sound, AM or FM

If a short circuit of the B+ line exists Q-801 will be damaged. First locate the short circuit and then replace Q-801(2SC 1060) in the power supply circuit.

A possible short circuit area is the AM variable capacitor(B+ is applied to the first vane). In this case add a 0.04 uF capacitor between terminal 2 of the AM PC board and the variable capacitor and then replace Q-801.

Tuner functions but no sound emerges from speakers.

Fuse F-801 and/or F-802 blown

power amplifier malfunction

1. If F-801/802 blow, check speaker terminals for short circuited condition. Check idle current resistors VR-601/602 for broken wires before replacing fuses.

To repair, leave fuse F-802 as is, short around the F-802 fuseholder, replace F-801. F-801 alone will provide adequate circuit protection.

2. Power transistor failure Q-611 through Q-614.

Power Transistor Replacement.

Remove the defective transistor. Check the DC voltage at terminal 3 or 4 of the power amplifier PC board, it should be within the range of 100mV, if the voltage at the applicable terminal greatly exceeds the range of 100mV the problem is in a proceeding stage.

Check and repair proceeding stages before replacing power transistor.

3. If amplifier failure occurs because of fuse F-802 blowing, the problem will usually be found in Q-611, Q-612, Q-607 or Q-608 stages, not in Q-613, Q-614, Q-609 or Q-610 stages.

Heat sinks become excessively hot with no signal input.

Check connections and settings of idling current adjustment resistors VR-601 and VR-602.

Repair connections if defective and then adjust VR-601 and VR-602 so that current flow at terminals 21 and 22 of the power amplifier PC board becomes 10mA.

See IDLING CURRENT ADJUSTMENT.

Amplifier will not turn on

F-001 blown, defective AC cord. Defective power switch etc.

F-001 blown would tend to indicate a power supply defect. Check and repair power supply circuitry before replacing fuse.

TROUBLESHOOTING AG 6000 LATE MODEL

Poor FM sensitivity  
Low INPUT meter indication

When the antenna terminal voltage is approximately 25dB - 30dB (0dB=1uV) the normal INPUT meter deflection will be about mid scale. Low sensitivity may be caused by faulty soldering of antenna terminal or a malfunction of the IF circuitry transistors Q-201 - Q-203 or FM RF peripheral circuitry.

Poor FM sensitivity  
Normal INPUT meter indication

Q-206, IC(GA 7061P) or IF associated circuitry is malfunctioning. Replace IC or repair associated circuitry.

No output  
INPUT and TUNING meter indications are normal.

Defective Q-301 in multiplex circuit or muting circuit.

High sound range is abnormal (FM)

De emphasis circuit is improperly set for receiving frequency of the area. De Emphasis characteristic is 50 micro/sec for Japan and Europe, 75 micro/sec for USA.

To convert the de emphasis circuit from 75 micro/sec to 50 micro/sec, leave out C-319 and C-320 (0.0012uF).

To convert from 50 micro/sec to 75 micro/sec reverse the above procedures.

Poor AM sensitivity

Damaged or faulty Q-401(2SK-14). Replace Q-401. If replacement is required add an external 10 ohm resistor in series to the drain.

Loud hum or buzz in AM reception

May be caused by strong AM field intensity, fluorescent lamps, or associated audio equipment.

If hum occurs remove filter capacitors C-002 and C-003 (1500pF) from chassis ground, connect them in parallel across power transformer primary winding, or remove C-002 and C-003 and connect a 0.01uF/500V capacitor across the power transformer primary winding. See connection below.

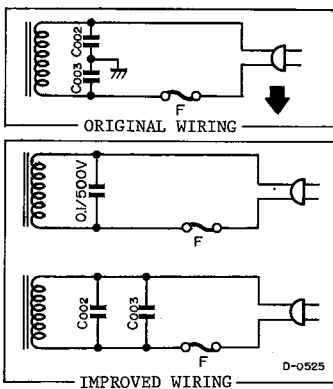

No sound, AM or FM  
(Malfunction of tuner power  
supply circuit)

If a short circuit of the B+ line exists Q-801 will be damaged. First locate the short circuit and then replace Q-801(2SC 1060) in the power supply circuit.

A possible short circuit area is the AM variable capacitor(B+ is applied to the first vane). In this case add a 0.04 uF capacitor between terminal 2 of the AM PC board and the variable capacitor and then replace Q-801.

Tuner functions but no  
sound emerges from speakers.

Fuse F-801 and/or F-802  
blown

(power amplifier malfunction)

1. If F-801/802(3A) fuse blow, check speaker terminals for short circuited condition or defective fuse. Check idle current resistors VR-601/602 for broken wires before replacing fuses.

To repair, leave fuse F-802 as is, short around the F-802 fuseholder, replace F-801. F-801 alone will provide adequate circuit protection.

2. Power transistor failure Q-611 through Q-614.

Power Transistor Replacement.

Remove the defective transistor. Check the DC voltage at terminal 3 or 4 of the power amplifier PC board, it should be within the range of  $\pm 100\text{mV}$ , if the voltage at the applicable terminal greatly exceeds the range of  $\pm 100\text{mV}$  the problem is in Q-607 - Q-610 stage.

Check and repair proceeding stages before replacing power transistor.

3. If amplifier failure occurs because of fuse F-802 blowing, the problem will usually be found in Q-611, Q-612, Q-607 or Q-608 stages, not in Q-613, Q-614, Q-609 or Q-610 stages.

Heat sinks become excessively  
hot with no signal input.

Check connections and settings of idling current adjustment resistors VR-601 and VR-602.

Repair connections if defective and then adjust VR-601 and VR-602 so that current flow at terminals 21 and 22 of the power amplifier PC board becomes 10mA.

Amplifier will not turn on

F-001 blown, defective AC cord.  
Defective power switch etc.

F-001 blown would tend to indicate a power supply defect. Check and repair power supply circuitry before replacing fuse.

TROUBLESHOOTING AG 6000 EARLY MODEL

Poor FM sensitivity  
Low meter indication

When the antenna terminal voltage is approximately 25 dB the normal meter deflection will be about mid scale.

Low sensitivity may be caused by faulty soldering of antenna terminal or a malfunction of the IF circuitry transistors (except IC), or FM RF amplifier.

If AGC voltage is -0.5V (with normal antenna terminal voltage of approx 60 dB) problem area is limited to Q-202, Q-203 and Q-204 of the IF circuitry, and their peripheral circuitry.

Poor FM sensitivity  
Normal INPUT meter indication

Q-205 IC or associated circuitry is malfunctioning. Replace IC or repair associated circuitry.

No output, INPUT and TUNING meter indications are normal. Signal measured at RECORD terminal.

Either Q-301(2SC458C) in multiplex circuit or the muting circuit is malfunctioning.

High sound range is abnormal (FM)

De emphasis circuit is improperly set for receiving frequency of the area.

De Emphasis characteristic is 50 micro/sec for Japan and Europe, 75 micro/sec for USA.

To convert the de emphasis circuit from 75 micro/sec to 50 micro/sec, change C-317 and C-318 (390 pF) to 200 pF.

To convert from 50 micro/sec to 75 micro/sec reverse the above procedures.

Poor AM sensitivity

Damaged or faulty Q-401.

Replace Q-401(2SK-19BL). If replacement is required add an external 10 ohm resistor in series to the drain.

Loud hum or buzz in AM reception

May be caused by strong AM field intensity, fluorescent lamps, or associated audio equipment.

If hum occurs remove filter capacitors C-002 and C-003 (1500 pF) from chassis ground, connect them in parallel across power transformer primary winding, or remove C-002 and C-003 and connect a 0.01 uF/500V capacitor across the power transformer primary winding. See connection below.

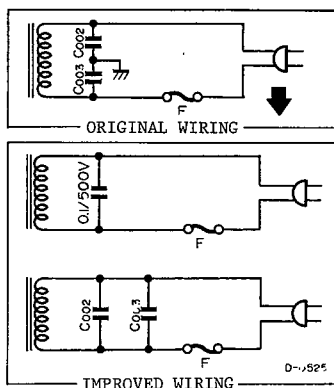

CONTINUED

No sound, AM or FM

If a short circuit of the B+ line exists Q-801 will be damaged. First locate the short circuit and then replace Q-801(2SC 1060) in the power supply circuit.

A possible short circuit area is the AM variable capacitor(B+ is applied to the first vane). In this case add a 0.04 uF capacitor between terminal 2 of the AM PC board and the variable capacitor and then replace Q-801.

Tuner functions but no sound emerges from speakers.

Fuse F-801 and/or F-802 blown

power amplifier malfunction

1. If F-801/802 blow, check speaker terminals for short circuited condition. Check idle current resistors VR-601/602 for broken wires before replacing fuses.

To repair, leave fuse F-802 as is, short around the F-802 fuseholder, replace F-801. F-801 alone will provide adequate circuit protection.

2. Power transistor failure Q-611 through Q-614.

Power Transistor Replacement.

Remove the defective transistor. Check the DC voltage at terminal 3 or 4 of the power amplifier PC board, it should be within the range of 100mV, if the voltage at the applicable terminal greatly exceeds the range of 100mV the problem is in a proceeding stage.

Check and repair proceeding stages before replacing power transistor.

3. If amplifier failure occurs because of fuse F-802 blowing, the problem will usually be found in Q-611, Q-612, Q-607 or Q-608 stages, not in Q-613, Q-614, Q-609 or Q-610 stages.

Heat sinks become excessively hot with no signal input.

Check connections and settings of idling current adjustment resistors VR-601 and VR-602.

Repair connections if defective and then adjust VR-601 and VR-602 so that current flow at terminals 21 and 22 of the power amplifier PC board becomes 10mA.

See IDLING CURRENT ADJUSTMENT.

Amplifier will not turn on

F-001 blown, defective AC cord.  
Defective power switch etc.

F-001 blown would tend to indicate a power supply defect. Check and repair power supply circuitry before replacing fuse.



## TROUBLESHOOTING AG 3000

- Poor FM sensitivity  
Low INPUT meter indication
- When the antenna terminal voltage is approximately 25 dB the normal meter deflection will be about mid scale.  
Low sensitivity may be caused by faulty soldering of antenna terminal or a malfunction of the IF circuitry transistors (except IC), or FM RF amplifier.  
If AGC voltage is -0.5V (with normal antenna terminal voltage of approx 60 dB) problem area is limited to Q-202, Q-203 and Q-204 of the IF circuitry, and their peripheral circuitry.
- Poor FM sensitivity  
Normal INPUT meter indication
- Q-201 IC or IF associated circuitry is malfunctioning. Replace IC or repair associated circuitry.
- No output, INPUT and TUNING meter indications are normal (Signal measured at RECORD terminal)
- Either Q-301(2SC458C) in multiplex circuit or the muting circuit is malfunctioning.
- High sound range is abnormal (FM)
- De emphasis circuit is improperly set for receiving frequency of the area.  
De Emphasis characteristic is 50 micro/sec for Japan and Europe, 75 micro/sec for USA.
- To convert the de emphasis circuit from 75 micro/sec to 50 micro/sec, change C-317 and C-318 (390 pF) to 200 pF.  
To convert from 50 micro/sec to 75 micro/sec reverse the above procedures.
- NOTE
- If the MPX board has been changed(PC Board No. 3008-1), to convert from 75 micro/sec to 50 micro/sec, change C-319(0.0015uF) and C-320(0.0015uF) respectively to 470 pF.  
To convert from 50 micro/sec to 75 micro/sec, reverse the process.
- Poor AM sensitivity
- Damaged or faulty Q-401.  
Replace Q-401(2SK-19BL). If replacement is required add an external 10 ohm resistor in series to the drain.
- Loud hum or buzz in AM reception
- May be caused by strong AM field intensity, fluorescent lamps, or associated audio equipment.

If hum occurs remove filter capacitors C-002 and C-003 (1500 pF) from chassis ground, connect them in parallel across power transformer primary winding, or remove C-002 and C-003 and connect a 0.01 uF/500V capacitor across the power transformer primary winding.  
See connection below.

No sound, AM or FM

If a short circuit of the B+ line exists Q-801 will be damaged. First locate the short circuit and then replace Q-801(2SC 1060) in the power supply circuit.

A possible short circuit area is the AM variable capacitor(B+ is applied to the first vane). In this case add a 0.04 uF capacitor between terminal 2 of the AM PC board and the variable capacitor and then replace Q-801.

Tuner functions but no sound emerges from speakers.

Fuse F-801 and/or F-802 blown

power amplifier malfunction

1. If F-801/802(2A) blow, check speaker terminals for short circuited condition. Check idle current resistors VR-601/602 for broken wires before replacing fuses.

To repair, leave fuse F-802 as is, short around the F-802 fuseholder, replace F-801. F-801 alone will provide adequate circuit protection.

2. Power transistor failure Q-611 through Q-614.

Power Transistor Replacement.

Remove the defective transistor. Check the DC voltage at terminal 3 or 4 of the power amplifier PC board, it should be within the range of  $\pm 100\text{mV}$ , if the voltage at the applicable terminal greatly exceeds the range of  $\pm 100\text{mV}$  the problem is in a proceeding stage.

Check and repair proceeding stages before replacing power transistor.

3. If amplifier failure occurs because of fuse F-802 blowing, the problem will usually be found in Q-611, Q-612, Q-607 or Q-608 stages, not in Q-613, Q-614 Q-609 or Q-610 stages.

Heat sinks become excessively hot with no signal input.

Check connections and settings of idling current adjustment resistors VR-601 and VR-602.

Repair connections if defective and then adjust VR-601 and VR-602 so that current flow at terminals 21 and 22 of the power amplifier PC board becomes 10mA.

See IDLING CURRENT ADJUSTMENT.

Amplifier will not turn on

F-001 blown, defective AC cord.  
Defective power switch etc.

F-001 blown would tend to indicate a power supply defect. Check and repair power supply circuitry before replacing fuse.

# COMPONENTS LOCATION (CONTINUED)

AG 7000

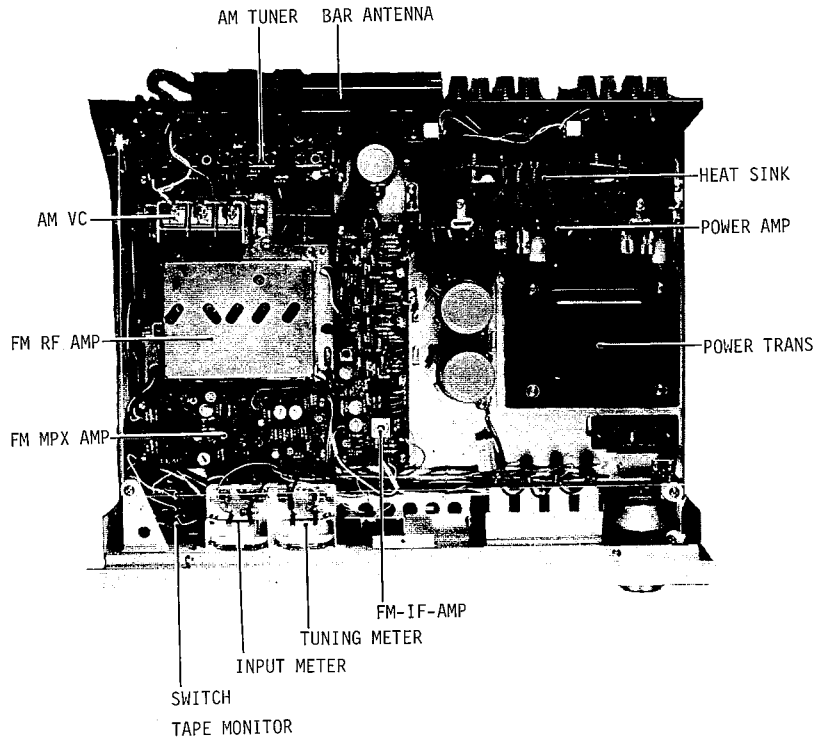

TOP VIEW

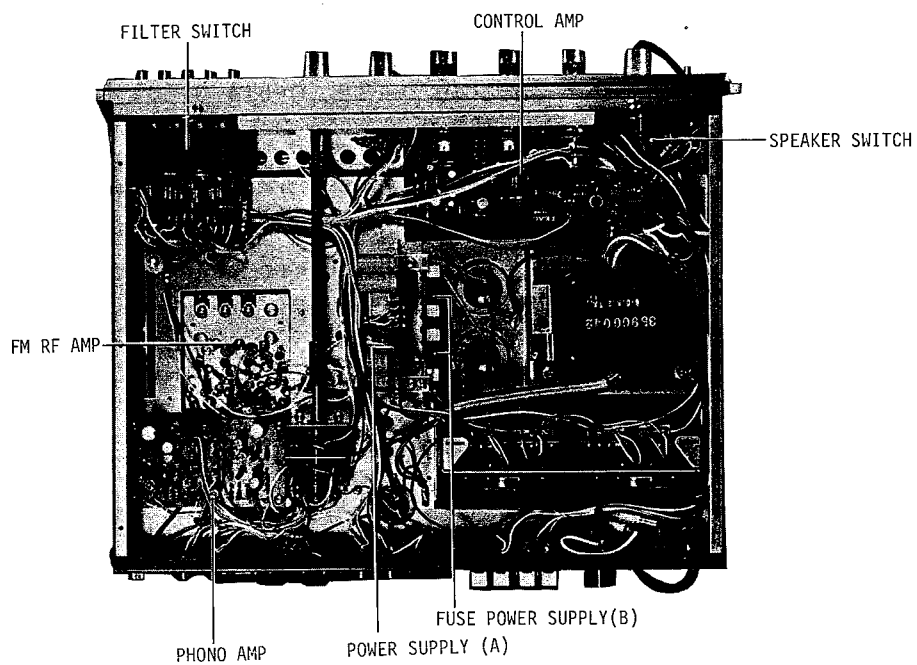

BOTTOM VIEW

COMPONENTS LOCATION (CONT'D)  
AG 6000

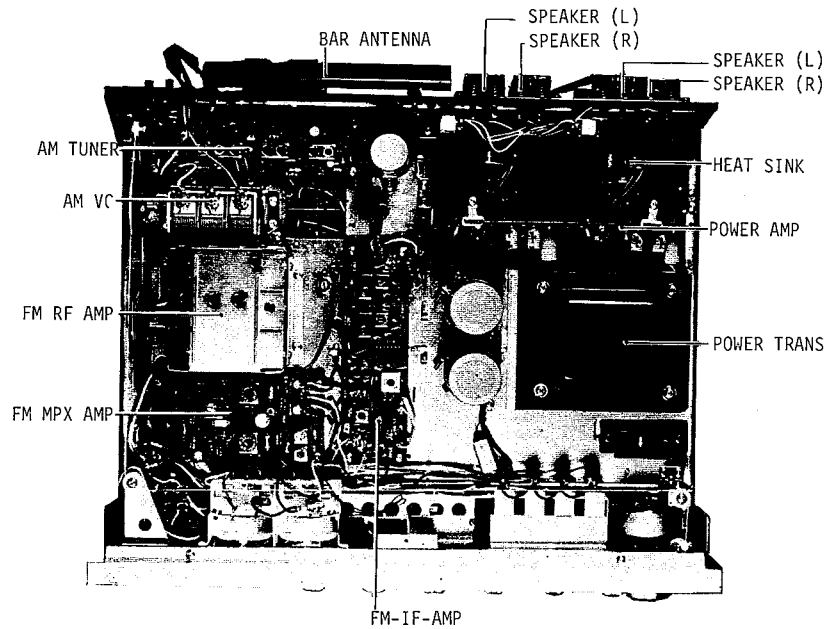

TOP VIEW

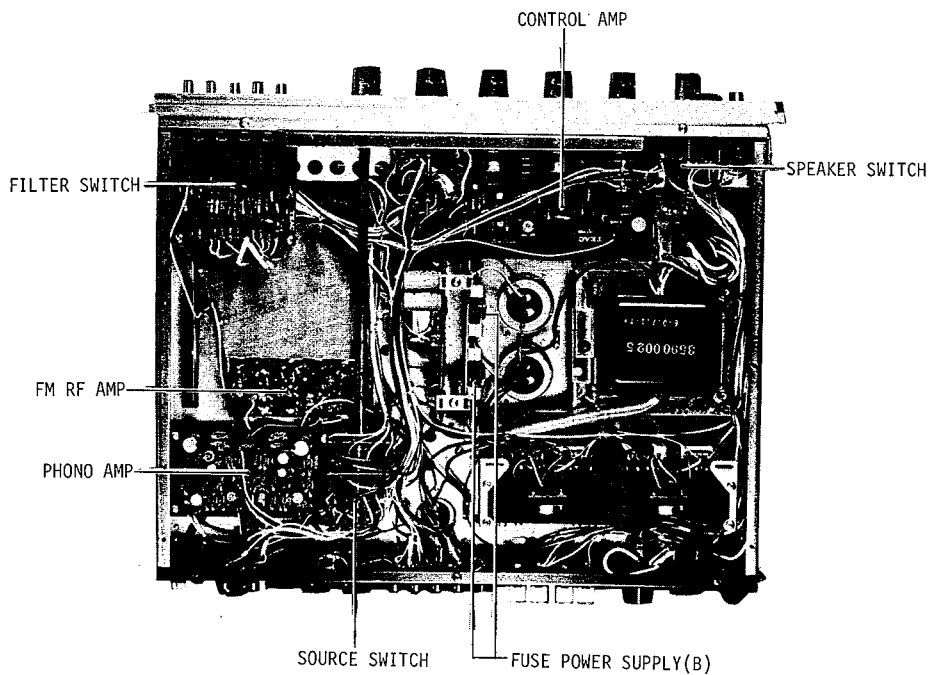

BOTTOM VIEW

COMPONENTS LOCATION (CONT'D)  
AG 3000

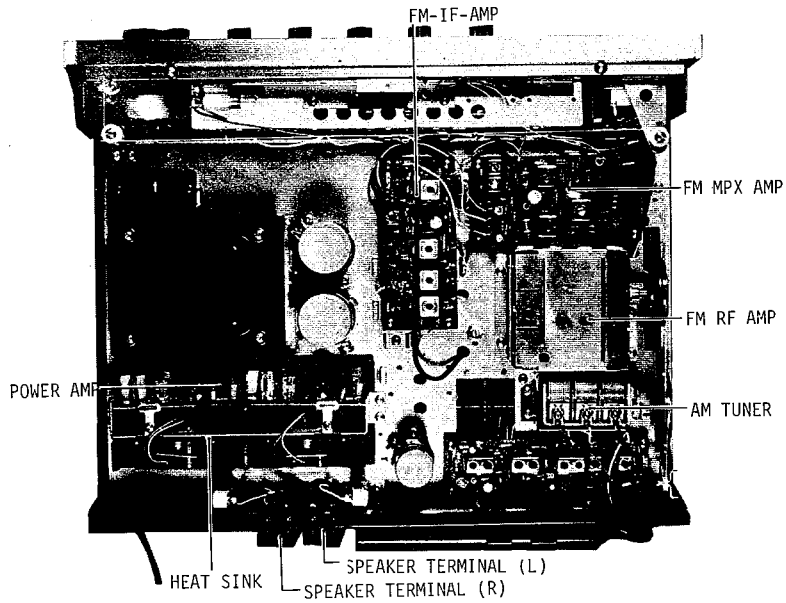

TOP VIEW

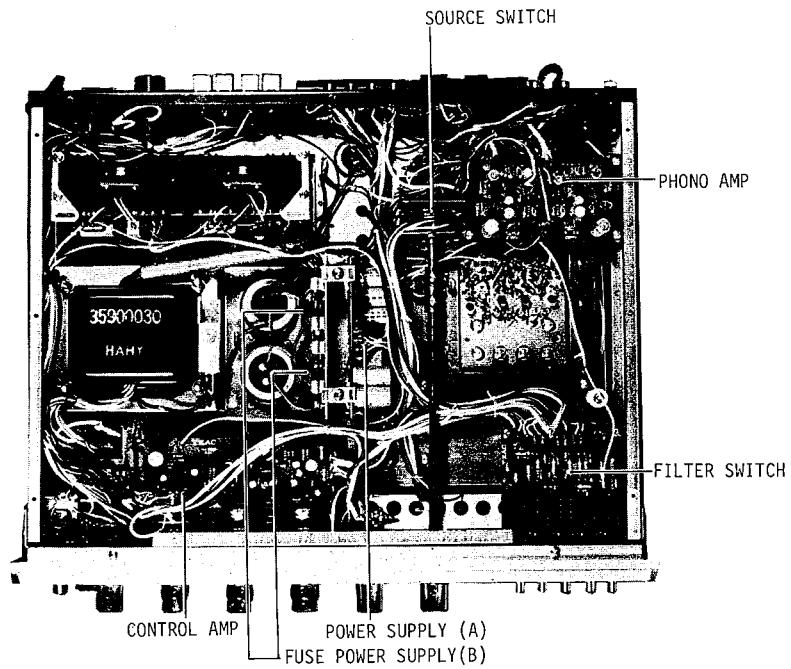

BOTTOM VIEW

CORRECTION SHEET

CORRECTION 1. ALIGNMENT PROCEDURE  
GENERAL NOTICE

WRONG	CORRECT
SET UP FOR 1-7	SET UP FOR 1-5
SET UP FOR 1-5	SET UP FOR 1-6

CORRECTION 2. FM ALIGNMENT PROCEDURE AG-6000 LATE MODEL

WRONG	CORRECT				
<table style="width: 100%; border-collapse: collapse;"> <tr> <td style="border: 1px solid black; padding: 5px; text-align: center;">ADJUST</td> </tr> <tr> <td style="border: 1px solid black; padding: 5px;"> <p>L-105 (local osc)</p> <p>TC-105 (local osc)</p> </td> </tr> </table>	ADJUST	<p>L-105 (local osc)</p> <p>TC-105 (local osc)</p>	<table style="width: 100%; border-collapse: collapse;"> <tr> <td style="border: 1px solid black; padding: 5px; text-align: center;">ADJUST</td> </tr> <tr> <td style="border: 1px solid black; padding: 5px;"> <p>L-105 (local osc)</p> <p>L-101 - 104 (RF AMP)</p> <p>TC-104 (local osc)</p> <p>TC-101 - 104 (RE AMP)</p> </td> </tr> </table>	ADJUST	<p>L-105 (local osc)</p> <p>L-101 - 104 (RF AMP)</p> <p>TC-104 (local osc)</p> <p>TC-101 - 104 (RE AMP)</p>
ADJUST					
<p>L-105 (local osc)</p> <p>TC-105 (local osc)</p>					
ADJUST					
<p>L-105 (local osc)</p> <p>L-101 - 104 (RF AMP)</p> <p>TC-104 (local osc)</p> <p>TC-101 - 104 (RE AMP)</p>					

CORRECTION 3. FM ALIGNMENT PROCEDURE AG-6000 LATE MODEL

Mistakes are found in the steps 3 to 5. See the steps 3 to 5 of AG 7000 as the both steps of AG 6000 and AG 7000 are the same.

CORRECTION 4. TROUBLE SHOOTING AG-7000

WRONG

To convert the de emphasis circuit from 75 micro/sec to 50 micro/sec, change C-319 and C-320 (390 pF) to 200 pF.  
To convert from 50 micro/sec to 75 micro/sec reverse the above procedures.

CORRECT

To convert the de emphasis circuit from 75 micro/sec to 50 micro/sec, leave out C-319 and C-320 (390 pF).  
To convert from 50 micro/sec to 75 micro/sec reverse the above procedures.

CORRECTION 5. TROUBLE SHOOTING AG-6000 LATE MODEL

WRONG	CORRECT
Q-401(2SK-14)	Q-401(2SK-19BL)

**PARTS LIST — AG 3000 —****FRONT PANEL SECTION**

REF NO.	TEAC PARTS NO.	DESCRIPTION	1st	2nd	3rd
	50930760	Panel Assy, Front			
	50930720	Panel, Front			
	50930780	Dial Back Plate			
	50928660	Trim Sash, A			
	50928670	Trim Sash, B			
	50929660	Cushion			
	50928700	Push Button, Small			
	50928720	Escutcheon, Push Button			
	50928690	Push Button, Power SW			
	50928730	Escutcheon, Power SW			
	50929270	Knob, A, Tuning			
	50929280	Knob, B, Speaker and Source			
	50929290	Knob, C, Rear			
	50929300	Knob, D, Front			
	50935460	Wooden Case			
	50929420	Mount Foot			

**FRONT CHASSIS SECTION**

REF NO.	TEAC PARTS NO.	DESCRIPTION	1st	2nd	3rd
	50928420	Chassis, Front			
S003	50928830	SW, Three Push Button			
S002	50929800	SW, Mode			
S003	50930680	SW, Speaker			
S004	50443430	SW, Push, Power			
J009	50432440	Phone Jack, Headphone 3P			
	50412180	1P Fuse Holder			
E002-006	50414320	Lamp, Glass Tube 8V 0.2A			
E011	50414320	Lamp, Glass Tube 8V 0.2A			
M001	50930830	Tuning Meter			
E008	50414360	Lamp, 8V 0.15A			
	50415130	Socket, Lamp			
	50928560	Dial Reflex Plate			
E001	50414380	Lamp, Indicator 8V 30mA			
	50277570	Grommet			
	50928570	Dial Shaft Bearing			
	50928900	Dial Shaft			
	50928750	Flywheel			
	50929130	Pulley			
	50930840	Dial Scale Plate			
	50928740	Dial Pointer			
E007	50414370	Lamp, Dial Pointer 8V 30mA			
	50929380	Grommet			
	50928910	Grommet, SW Bearing			

**PARTS LIST**  
AG-3000

REF NO.	TEAC PARTS NO.	DESCRIPTION	1st	2nd	3rd
	50928810	PC Board Assy, Control SW			
	50925420	PC Board, Control SW			
TR901-904	50423930	Silicon Transistor, 2SC458LG(C)			
VR901	50929160	Potentiometer, Volume-Balance 250k × 2			
VR902-903	50929170	Potentiometer, Tone Control			
	50930670	PC Board Assy, Filter SW			
	50925460	PC Board, Filter SW			
S1-5	50930950	SW, Five Button			

**MAIN CHASSIS SECTION**

REF NO.	TEAC PARTS NO.	DESCRIPTION	1st	2nd	3rd
	50928220	Chassis, Main			
VC001	50929190	AM Variable Capacitor			
	50928970	Dial Drum			
	50929880	FM RF Amplifier			
T001	50930820	Transformer, Power			
E009	50927610	Voltage Selector			
S001	50929080	SW, Source			
	50929090	Source SW Shaft			
	50929100	Source SW Shaft Joint			
	50452500	Terminal Strip, 1L4P			
	50929130	Pulley			
	50931940	Bonnet			
	50929410	Dial Cord			
	50929120	Snap Bushing			
	50928390	Bottom Cover			
	50929420	Mount Foot			
VR001	50533610	Trimmer Resistor, Separation V16N-5kΩB			
	50929011	PC Board Assy, AM Tuner			
	50925360	PC Board, AM Tuner			
TR401	50423710	FET, 2SK19 BL			
TR402-404	50423250	Silicon Transistor, 2SC372Y			
D401-405	50422130	Diode, IN60			
L401	50929490	Coil, RF 103B			
L402	50929500	Coil, AM Oscillator 404L			
L403-405	50929540	Inductor, RF 100μH			
T401	50929510	AM IFT (1) 404A			
T402	50929520	AM IFT (2) 402B			
T403	50929530	AM IFT (3) 403D			
VR401	50533580	Trimmer Resistor, 4.7k B			
VR402	50533520	Trimmer Resistor, 47k B			



REF NO.	TEAC PARTS NO.	DESCRIPTION	1st	2nd	3rd
	50930660	PC Board Assy, FM IF			
	50930640	PC Board, FM IF			
IC201	50427020	IC, TA-7027M			
TR201-202	50423940	Silicon Transistor, 2SC460(B)			
TR203	50426050	Silicon Transistor, 2SC460(A)			
D202-205	50422410	Diode, 1N34AY			
T201	50930610	FM IFT (2) 202A			
T202	50930620	FM IFT (3) 202B			
T203	50930630	FM IFT (4) 202C			
T204	50930870	Transformer, Discriminator 204D			
T205	50929570	FM IFT (1) 202E			
CR201	50929900	CR Unit			
VR201	50533600	Trimmer Resistor, 100k B			
	50929890	PC Board Assy, FM MPX			
	50929910	PC Board, FM MPX			
TR301	50423950	Silicon Transistor, 2SC458G(C)			
TR302	50424000	Silicon Transistor, 2SC458(B)			
TR303	50423950	Silicon Transistor, 2SC458(C)			
TR304-305	50426010	Silicon Transistor, 2SC458(D)			
L301	50929820	Coil, SCA Filter			
L302	50929840	Coil, FM MPX 19kHz (1)			
T301	50929860	Coil, FM MPX 19kHz (2)			
T302	50929850	Coil, FM MPX 19kHz (3)			
T303	50929830	Coil, FM MPX 38kHz			
D301-306	50422410	Diode, 1N34AY			
D307	50422460	Diode, Silicon 1S1212			
CR301-302	50929610	CR Filter Unit, FP-38A			
	50452520	Terminal Strip, 1L3P			
	50929000	PC Board Assy, Phono Amp			
	50929210	PC Board, Phono Amp			
TR501a-b	50423930	Silicon Transistor, 2SC458LG(C)			
	50930980	PC Board Assy, Power Amp			
	50925480	PC Board, Power Amp			
TR601-604	50423531	Silicon Transistor, 2SA561Y			
TR605-608	50423570	Silicon Transistor, 2SC497Y			
TR609-610	50426060	Silicon Transistor, 2SA497Y			
D605-606	50422440	Diode, Silicon S3016R			
D607-608	50422430	Diode, Silicon V06C			
E601-602	50920930	R-L Unit			
	50928290	Heat Sink, A			
	50434720	Socket, Power Transistor			
	50426040	Silicon Transistor, Power 2SC1030(B)			
	50925510	PC Board, Diode			
	50929700	Spring, PC Board Retainer			
D601-604	50422440	Diode, Silicon S3016R			

**PARTS LIST**  
AG-3000

REF NO.	TEAC PARTS NO.	DESCRIPTION	1st	2nd	3rd
	50929040	PC Board Assy, Power Supply, A			
	50925530	PC Board, Power Supply, A			
TR801	50423980	Silicon Transistor, 2SC1060B			
	50928550	Heat Sink, B			
D805·806	50422430	Diode, V06C			
D807	50422450	Diode, Zener 1S337 or 1S759A			
	50930990	PC Board Assy, Power Supply, B			
	50925550	PC Board, Power Supply, B			
F801·802	50411240	Fuse, 2A			
D801-804	50422470	Silicon Diode, V03C			
	50412190	Fuse Holder For PC Board			

**REAR PANEL SECTION**

REF NO.	TEAC PARTS NO.	DESCRIPTION	1st	2nd	3rd
	50930750	Panel, Rear			
L001	50922730	Transformer, RF Balun			
J001	50454060	Antenna Terminal, 4P			
J002·003	50430190	Pin Jack, US 4P			
J008	50430180	Pin Jack, US 1P			
	50929120	Snap Bushing			
J006·007	50451090	Output Terminals, 4P			
	50924500	Fuse Holder			
F001	50411210	Fuse, 2A			
J005	50924510	Receptacle, AC Outlet			
E010	50471651	AC Cord			
J010	50926120	GND Terminal			
J004	50430010	Connector, DIN			
	50452510	Terminal Strip, 1L2P			
	50452530	Terminal Strip, 2L3P			
L002	50929150	Bar Antenna			

## PARTS LIST — AG6000 —

## FRONT PANEL SECTION

REF NO.	TEAC PARTS NO.	DESCRIPTION	1st	2nd	3rd
	50931340	Panel Assy, Front			
	50931320	Panel, Front			
	50929980	Dial Back Plate			
	50928660	Trim Sash, A			
	50928670	Trim Sash, B			
	50929660	Cushion			
	50928700	Push Button, Small			
	50928720	Escutcheon, Push Button			
	50928690	Push Button, Power SW			
	50928730	Escutcheon, Power SW			
	50929270	Knob, A, Tuning			
	50929280	Knob, B, Speaker and Source			
	50929290	Knob, C, Rear			
	50929300	Knob, D, Front			
	50935460	Wooden Case			
	50929420	Mount Foot			

## FRONT CHASSIS SECTION

REF NO.	TEAC PARTS NO.	DESCRIPTION	1st	2nd	3rd
	50931910	Chassis, Front			
S002	50928830	SW, Three Push Button			
S003	50929800	SW, Mode			
S005	50928850	SW, Speaker			
S006	50443430	SW, Push, Power			
J011	50432440	Phone Jack, Headphone 3P			
M002	50928860	Input Meter			
	50412180	1P Fuse Holder			
E002	50414320	Lamp, Glass Tube 8V 0.2A			
E004-009	50414320	Lamp, Glass Tube 8V 0.2A			
M001	50928870	Tuning Meter			
E001-003	50414360	Lamp, 8V 0.15A			
E011-012	50414360	Lamp, 8V 0.15A			
	50415130	Socket, Lamp			
	50928560	Dial Reflex Plate			
E013	50414380	Lamp, Indicator 8V 30mA			
	50277570	Grommet			
	50928610	Indicator Shield Plate			
	50928570	Dial Shaft Bearing			
	50928900	Dial Shaft			
	50928750	Flywheel			
	50929130	Pulley			
	50931300	Dial Scale Plate			
	50928740	Dial Pointer			
E010	50414370	Lamp, Dial Pointer 8V 30mA			

**PARTS LIST**  
AG-6000

REF NO.	TEAC PARTS NO.	DESCRIPTION	1st	2nd	3rd
	50929380	Grommet			
	50928910	Grommet, SW Bearing			
	50928810	PC Board Assy, Control SW			
	50925420	PC Board, Control SW			
TR901-904	50423930	Silicon Transistor, 2SC458LG(C)			
VR901	50929160	Potentiometer, Volume-Balance 250k × 2			
VR902-903	50929170	Potentiometer, Tone Control			
	50928820	PC Board Assy, Filter SW			
	50925440	PC Board, Filter SW			
S1-5	50929180	SW, Five Button			

**MAIN CHASSIS SECTION**

REF NO.	TEAC PARTS NO.	DESCRIPTION	1st	2nd	3rd
VC001	50928220	Chassis, Main			
	50929190	AM Variable Capacitor			
	50928970	Dial Drum			
	50929880	FM RF Amplifier			
T001	50929950	Transformer, Power			
E014	50927610	Voltage Selector			
S001	50929080	SW, Source			
	50929090	Source SW Shaft			
	50929100	Source SW Shaft Joint			
	50452500	Terminal Strip, 1L4P			
	50929130	Pulley			
	50931940	Bonnet			
	50929410	Dial Cord			
	50929120	Snap Bushing			
	50928390	Bottom Cover			
	50929420	Mount Foot			
VR001	50533610	Trimmer Resistor, Separation V16N-5kΩB			
	50929011	PC Board Assy, AM Tuner			
	50925360	PC Board, AM Tuner			
TR401	50423710	FET, 2SK19 BL			
TR402-404	50423250	Silicon Transistor, 2SC372Y			
D401-405	50422130	Diode, IN60			
L401	50929490	Coil, RF 103B			
L402	50929500	Coil, AM Oscillator 404L			
L403-405	50929540	Inductor, RF 100μH			
T401	50929510	AM IFT (1) 404A			
T402	50929520	AM IFT (2) 402B			
T403	50929530	AM IFT (3) 403D			
VR401	50533580	Trimmer Resistor, 4.7kΩB			
VR402	50533520	Trimmer Resistor, 47kΩB			

REF NO.	TEAC PARTS NO.	DESCRIPTION	1st	2nd	3rd
	50931201	PC Board Assy, FM IF			
	50931210	PC Board, FM IF			
TR201-204	50423940	Silicon Transistor, 2SC460(B)			
IC201	50427070	IC, HA-1113			
D202-205	50422410	Diode, IN34AY			
E FIL201					
202	50931220	Ceramic Filter, EIC-10D249A			
T201-202	50931280	Transformer, Matching			
T203	50929810	Transformer, Discriminator			
T204	50929570	FM IFT (1)			
VR201-202	50533600	Trimmer Resistor, 100k B			
CR201	50929900	CR Unit			
	50929890	PC Board Assy, FM MPX			
	50929910	PC Board, FM MPX			
TR301	50423950	Silicon Transistor, 2SC458(C)			
TR302	50424000	Silicon Transistor, 2SC458(B)			
TR303	50423950	Silicon Transistor, 2SC458(C)			
TR304-305	50426010	Silicon Transistor, 2SC458(D)			
L301	50929820	Coil, SCA Filter			
L302	50929840	Coil, FM MPX 19kHz (1)			
T301	50929860	Coil, FM MPX 19kHz (2)			
T302	50929850	Coil, FM MPX 19kHz (3)			
T303	50929830	Coil, FM MPX 38kHz			
D301-306	50422410	Diode, 1N34AY			
D307	50422460	Diode, Silicon 1S1212			
CR301-302	50929610	CR Filter Unit, FP-38A			
	50452520	Terminal Strip, 1L3P			
	50929000	PC Board Assy, Phono Amp			
	50929210	PC Board, Phono Amp			
TR501a-b	50423930	Silicon Transistor, 2SC458LG(C)			
	50931310	PC Board Assy, Power Amp			
	50925480	PC Board, Power Amp			
TR601-604	50423531	Silicon Transistor, 2SA561Y			
TR605-608	50423570	Silicon Transistor, 2SC497Y			
TR609-610	50426060	Silicon Transistor, 2SA497Y			
D605-606	50422440	Diode, Silicon S3016R			
D607-608	50422430	Diode, Silicon V06C			
VR601-602	50533360	Trimmer Resistor, 500ΩB			
E601-602	50920930	R-L Unit			
	50928680	Heat Sink, C			
	50434720	Socket, Power Transistor			
	50426030	Silicon Transistor, Power 2SC897(B)			
	50925510	PC Board, Diode			
	50929700	Spring, PC Board Retainer			
D601-604	50422440	Diode, Silicon S3016R			

**PARTS LIST**  
AG 6000

REF NO.	TEAC PARTS NO.	DESCRIPTION	1st	2nd	3rd
TR801	50929040	PC Board Assy, Power Supply, A			
	50925530	PC Board, Power Supply, A			
	50423980	Silicon Transistor, 2SC1060B			
	50928550	Heat Sink, B			
D805-806	50422430	Diode, V06C			
D807	50422450	Diode, Zener 1S337 or 1S759A			
F801-802	50929050	PC Board Assy, Power Supply, B			
	50925550	PC Board, Power Supply, B			
	50411210	Fuse, 3A			
	D801-804	50422420	Silicon Diode, 1S1072		

**REAR PANEL SECTION**

REF NO.	TEAC PARTS NO.	DESCRIPTION	1st	2nd	3rd
	50929730	Panel, Rear			
L001	50569060	Transformer, RF Balun			
J001	50454060	Antenna Terminal, 4P			
J003	50430190	Pin Jack, US 4P			
J002	50430210	Pin Jack, US 8P			
J010	50452530	Terminal Strip, 2L3P			
	50430180	Pin Jack, US 1P			
J007-009	50929120	Snap Bushing			
	50451090	Output Terminals, 4P			
	50924500	Fuse Holder			
F001	50411220	Fuse, 3A			
J005-006	50924510	Receptacle, AC Outlet			
E015	50471651	AC Cord			
J012	50926120	GND Terminal			
J004	50430010	Connector, DIN			
L001	50452510	Terminal Strip, 1L2P			
	50929150	Bar Antenna			

**PARTS LIST — AG 7000 —****FRONT PANEL SECTION**

REF NO.	TEAC PARTS NO.	DESCRIPTION	1st	2nd	3rd
	50929250	Panel Assy, Front			
	50929740	Panel, Front			
	50929750	Dial Back Plate			
	50928660	Trim Sash, A			
	50928670	Trim Sash, B			
	50929660	Cushion			
	50928700	Push Button, Small			
	50928720	Escutcheon, Push Button			
	50928690	Push Button, Power SW			
	50928730	Escutcheon, Power SW			
	50929270	Knob, A, Tuning			
	50929280	Knob, B, Speaker and Source			
	50929290	Knob, C, Rear			
	50929300	Knob, D, Front			
	50929310	Knob, E, Front			
	50929320	Knob, F, Rear			
	50935460	Wooden Case			
	50929420	Mount Foot			

**FRONT CHASSIS SECTION**

REF NO.	TEAC PARTS NO.	DESCRIPTION	1st	2nd	3rd
	50931910	Chassis, Front			
S003	50928830	SW, Three Push Button			
S002	50928840	SW, Mode-Rec. Mode			
S006	50928850	SW, Speaker			
S007	50443430	SW, Push, Power			
J011	50432440	Phone Jack, Headphone			
M002	50928860	Input Meter			
	50412180	1P Fuse Holder			
E002	50414320	Lamp, Glass Tube 8V 0.2A			
E004-009	50414320	Lamp, Glass Tube 8V 0.2A			
M001	50928870	Tuning Meter			
E001-003	50414360	Lamp, 8V 0.15A			
E011-012	50414360	Lamp, 8V 0.15A			
	50415130	Socket, Lamp			
	50931930	Dial Reflex Plate			
E013	50414380	Lamp, Indicator 8V 30mA			
	50277570	Grommet			
	50928610	Indicator Shield Plate			
	50928570	Dial Shaft Bearing			
	50928900	Dial Shaft			
	50928750	Flywheel			
	50929130	Pulley			

**PARTS LIST**  
AG-7000

REF NO.	TEAC PARTS NO.	DESCI	1st	2nd	3rd
E010	50928920	Dial Scale Plate			
	50928740	Dial Pointer			
	50414370	Lamp, Dial Pointer 8V 30mA			
	50929380	Grommet			
	50928910	Grommet, SW Bearing			
TR901-904	50928810	PC Board Assy, Control SW			
	50925420	PC Board, Control SW			
	50423930	Silicon Transistor, 2SC458LG(C)			
VR901	50929160	Potentiometer, Volume-Balance 250k × 2			
VR902-903	50929170	Potentiometer, Tone Control			
S1.5	50928820	PC Board Assy, Filter SW			
	50925440	PC Board, Filter SW			
	50929180	SW, Five Button			

**MAIN CHASSIS SECTION**

REF NO.	TEAC PARTS NO.	DESCRIPTION	1st	2nd	3rd	
VC001	50928210	Chassis, Main				
	50929190	AM Variable Capacitor				
	50928970	Dial Drum				
	50923880	FM RF Amplifier				
	T001	50929070	Transformer, Power			
	E014	50927610	Voltage Selector			
	S001	50929080	SW, Source			
		50929090	Source SW Shaft			
		50929100	Source SW Shaft Joint			
		50452510	Terminal Strip, 1L4P			
		50929130	Pulley			
		50931940	Bonnet			
		50929410	Dial Cord			
		50929120	Snap Bushing			
		50928390	Bottom Cover			
		50929420	Mount Foot			
	L003	50452540	Terminal Strip, 1L1P			
50566390		Inductor, RF 100μH				
TR401	50929011	PC Board Assy, AM Tuner				
	50925360	PC Board, AM Tuner				
TR402-404	50423710	FET, 2SK19 BL				
D401-405	50423250	Silicon Transistor, 2SC372Y				
L401	50422130	Diode, IN60				
L402	50929490	Coil, RF 103B				
L403-405	50929500	Coil, AM Oscillator 404L				
T401	50929540	Inductor, RF 100μH				
T402	50929510	AM IFT (1) 404A				
T403	50929520	AM IFT (2) 402B				
VR401	50929530	AM IFT (3) 403D				
VR402	50533580	Trimmer Resistor, 4.7kΩB				
	50533520	Trimmer Resistor, 47kΩB				



REF NO.	TEAC PARTS NO.	DESCRIPTION	1st	2nd	3rd
	50929020	PC Board Assy, FM IF			
	50929200	PC Board, FM IF			
TR201-205	50423940	Silicon Transistor, 2SC460(B)			
IC201	50427040	IC, TA-7061P			
D201-204	50422130	Diode, IN60			
D205-206	50422410	Diode, IN34AY			
D207-211	50422130	Diode, IN60			
CFR201- 206	50929640	Ceramic Filter, CFR-107M			
L201	50566400	Inductor, RF 10 $\mu$ H			
L202-204	50929540	Inductor, RF 100 $\mu$ H			
T201	50929560	Transformer, Discriminator			
T202	50929570	FM IFT (I)			
VR201	50533480	Trimmer Resistor, SR19R 10k B			
VR202-203	50533520	Trimmer Resistor, SR19R 47k B			
	50928991	PC Board Assy, FM MPX			
	50925340	PC Board, FM MPX			
TR301	50423930	Silicon Transistor, 2SC458G(C)			
TR302	50423950	Silicon Transistor, 2SC458(C)			
IC301	50427060	IC, MC1305			
L301-302	50929580	Coil, SCA Filter			
L303-304	50929590	Coil, FM MPX 19kHz			
L305	50929600	Coil, FM MPX 38kHz			
L306-307	50929590	Coil, FM MPX 19kHz			
CR301-302	50929610	CR Filter Unit, FR-38A			
VR301	50533590	Trimmer Resistor, SR19R 1k $\Omega$ B			
	50929000	PC Board Assy, Phono Amp			
	50929210	PC Board, Phono Amp			
TR501a-b	50423930	Silicon Transistor, 2SC458LG(C)			
	50929031	PC Board Assy, Power Amp			
	50925480	PC Board, Power Amp			
TR601-604	50423531	Silicon Transistor, 2SA561Y			
TR605-608	50423960	Silicon Transistor, 2SC485BL			
TR609-610	50423970	Silicon Transistor, 2SA485BL			
D605-606	50422440	Diode, Silicon S3016R			
D607-608	50422430	Diode, Silicon V06C			
VR601-602	50533360	Trimmer Resistor, 500 $\Omega$ B			
E601-602	50920930	R-L Unit			
	50928680	Heat Sink, C			
	50434720	Socket, Power Transistor			
	50423920	Silicon Transistor, Power 2SD118BL			
	50925510	PC Board, Diode			
	50929700	Spring, PC Board Retainer			
D601-604	50422440	Diode, Silicon S3016-R			

**PARTS LIST**  
AG-7000

REF NO.	TEAC PARTS NO.	DESCRIPTION	1st	2nd	3rd
TR801	50929040	PC Board Assy, Power Supply, A			
	50925530	PC Board, Power Supply, A			
	50423980	Silicon Transistor, 2SC1060B			
	50928550	Heat Sink, B			
D805-806	50422430	Diode, V06C			
D807	50422450	Diode, Zener 1S337 or 1S759A			
F801-802	50929050	PC Board Assy, Power Supply, B			
	50925550	PC Board, Power Supply, B			
	50411210	Fuse, 3A			
D801-804	50422420	Silicon Diode, 1S-1072			

**REAR PANEL SECTION**

REF NO.	TEAC PARTS NO.	DESCRIPTION	1st	2nd	3rd
L002	50929730	Panel, Rear			
	50569060	Transformer, RF Balun			
J001	50454060	Antenna Terminal, 4P			
J003	50430190	Pin Jack, US 4P			
J002	50430210	Pin Jack, US 8P			
	50452530	Terminal Strip, 2L3P			
J010	50430180	Pin Jack, US 1P			
	50929120	Snap Bushing			
J007-009	50451090	Output Terminals, 4P			
	50924500	Fuse Holder			
F001	50411220	Fuse, 3A			
J005-006	50924510	Receptacle, AC Outlet			
E015	50471651	AC Cord			
J012	50926120	GND Terminal			
J004	50430010	Connector, DIN			
	50452510	Terminal Strip, 1L2P			
L001	50929150	Bar Antenna			

# **TEAC<sup>®</sup> AG-3000.6000.7000 SERIES**

**PRINTED CIRCUIT BOARD  
SCHEMATIC DIAGRAMS**

1st EDITION

---

## **TEAC CORPORATION**

SALES OFFICE: SHINJUKU BUILDING  
1-8-1, NISHI-SHINJUKU, SHINJUKU, TOKYO

U.S. DISTRIBUTOR: TEAC CORPORATION OF AMERICA  
7733 TELEGRAPH ROAD  
MONTEBELLO, CALIFORNIA 90640  
U.S.A.  
EUROPEAN DISTRIBUTOR: TEAC EUROPE N.V.  
KABELWEG 45-47, AMSTERDAM-W. 2,  
HOLLAND

---

### AG Series Parts Replacement Information

ICs in the MPX and FM IF section of the AG-7000 and AG-6000 (later models) may be interchanged with the numbers shown in the chart below. If interchanged ICs are to be installed certain circuit components must also be changed. See chart for revised circuit components.

BOARD PART & CIRCUIT REF NO.	ORIGINAL TYPE NO.	REPLACEMENT TYPE AND CIRCUIT COMPONENTS TO BE CHANGED TO VALUE SHOWN	
MPX Q-303 R-309	MC1305 120 ohm	change to change to	TN76105 220 ohm
FM IF Q-206 R-277 MPX R-303	TA7061P 6.7 kohm 1.2 kohm	change to change to change to	TA7061AP (Toshiba) 18 kohm 3.3 kohm
MPX FR Q-303 IF Q-206 R-227 R-303 R-309 R-320	MC1305 TA7061P 6.8 kohm 1.2 kohm 120 ohm 18 ohm	change to change to change to change to change to change to	TN76105 (Texas Instruments Co.) TA7061AP (Toshiba) 18 kohm 3.3 kohm 220 ohm 100 ohm

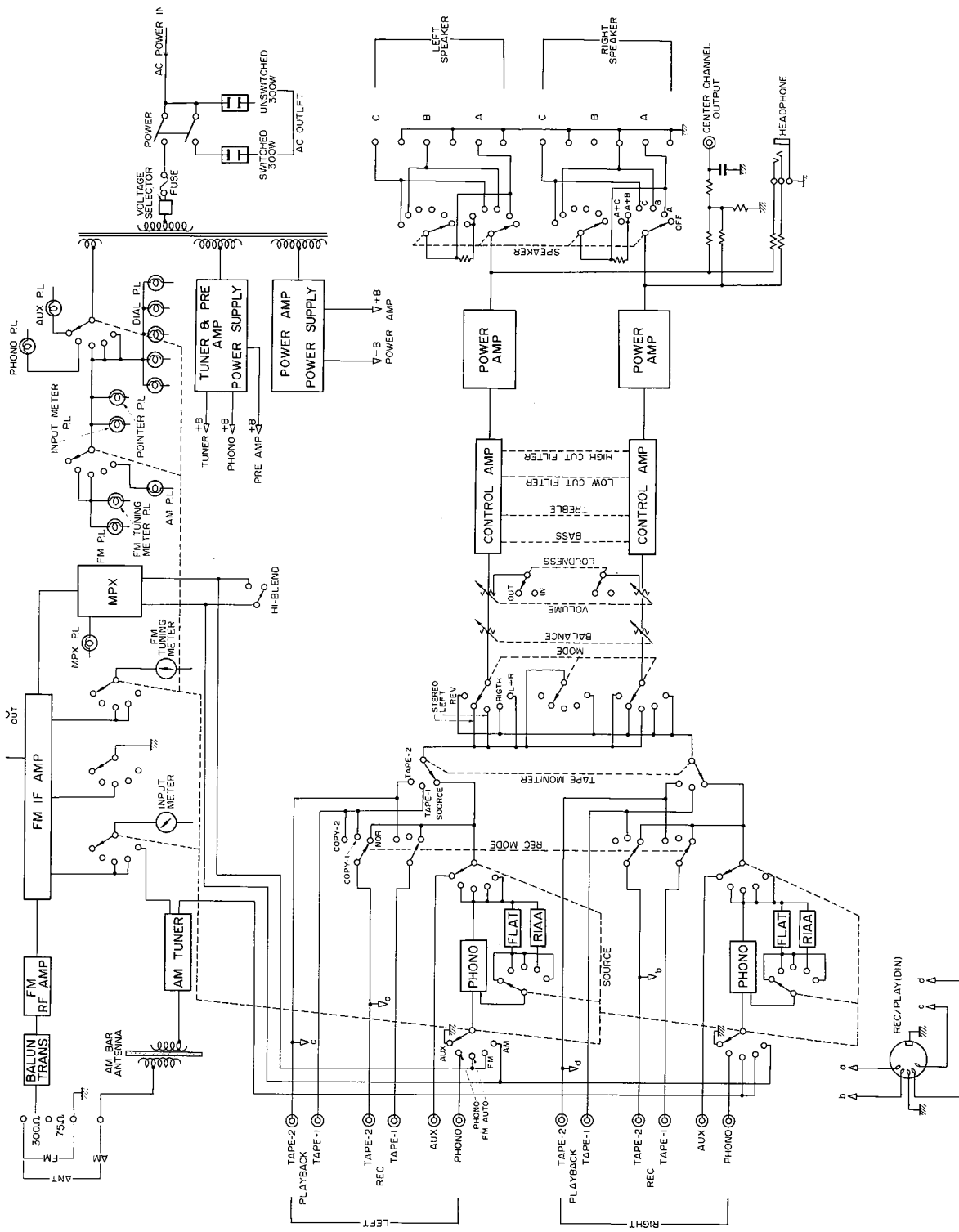

**TEAC AG-7000 BLOCK DIAGRAM**

TEAC AG-7000 SCHEMATIC DIAGRAM

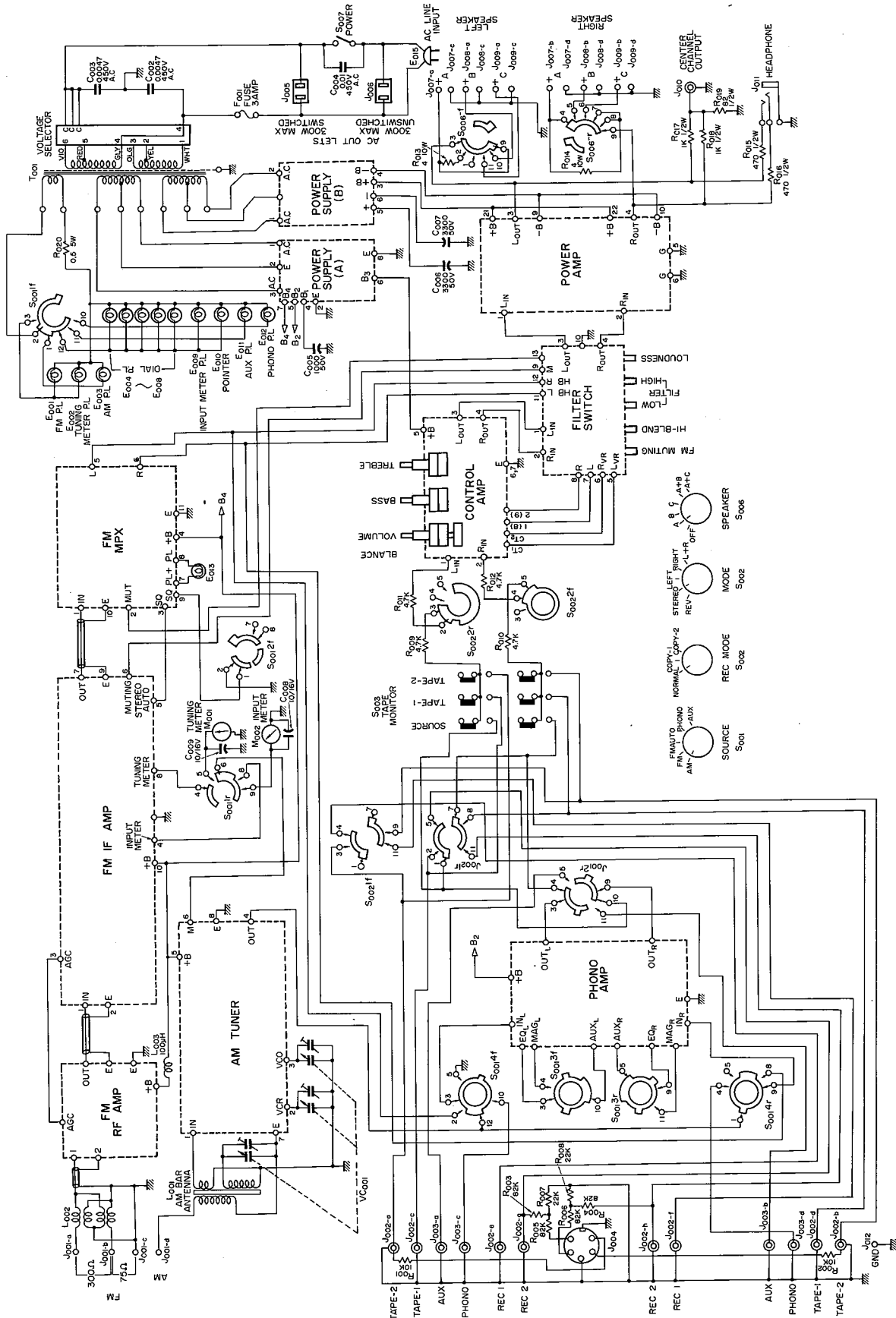

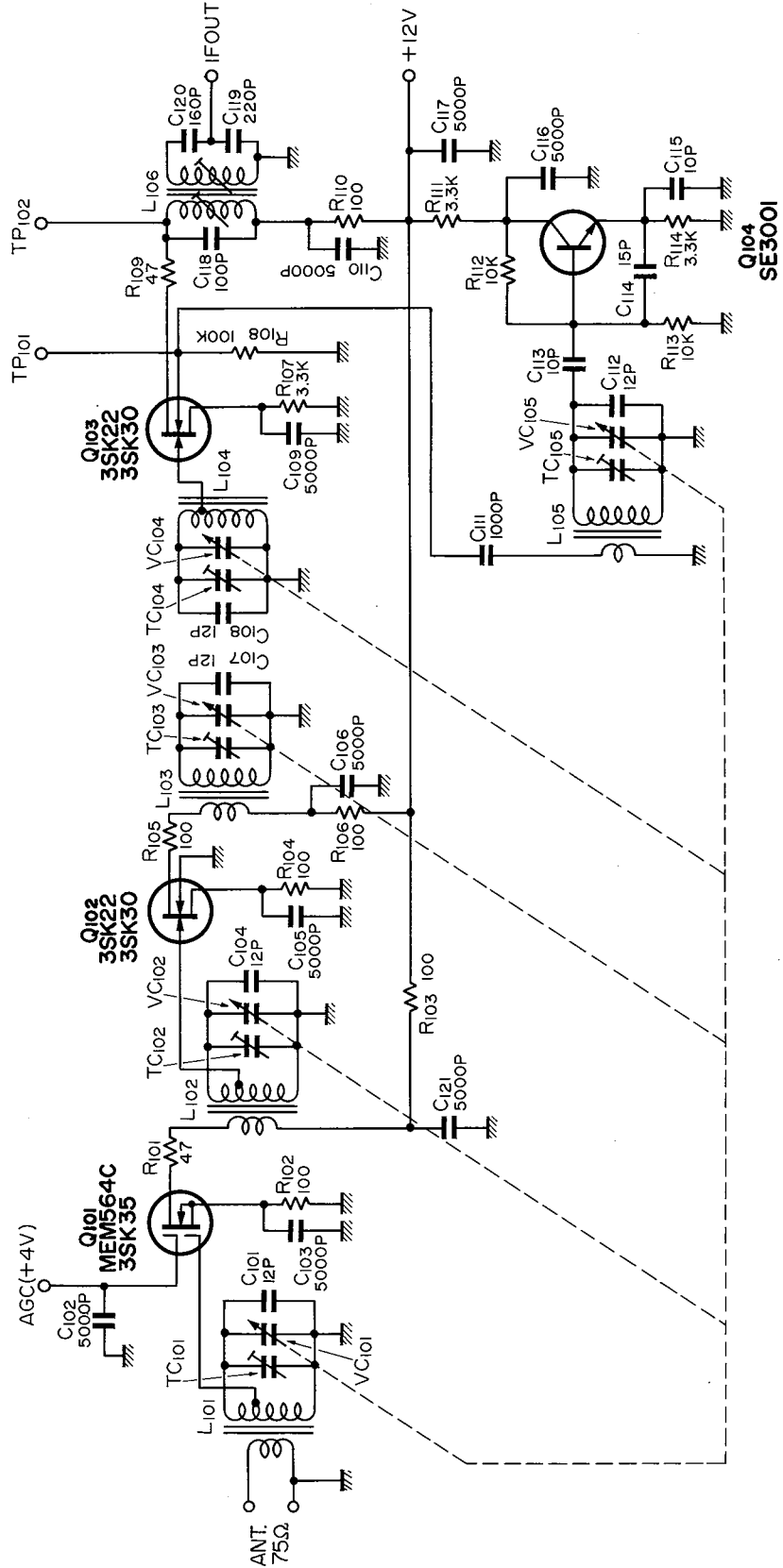

**TEAC AG-7000 SCHEMATIC DIAGRAM**  
**FM RF AMP**

# TEAC AG-7000 PC BOARD

## FM IF AMP

ALSO APPLICABLE AG 6000 LATE MODEL

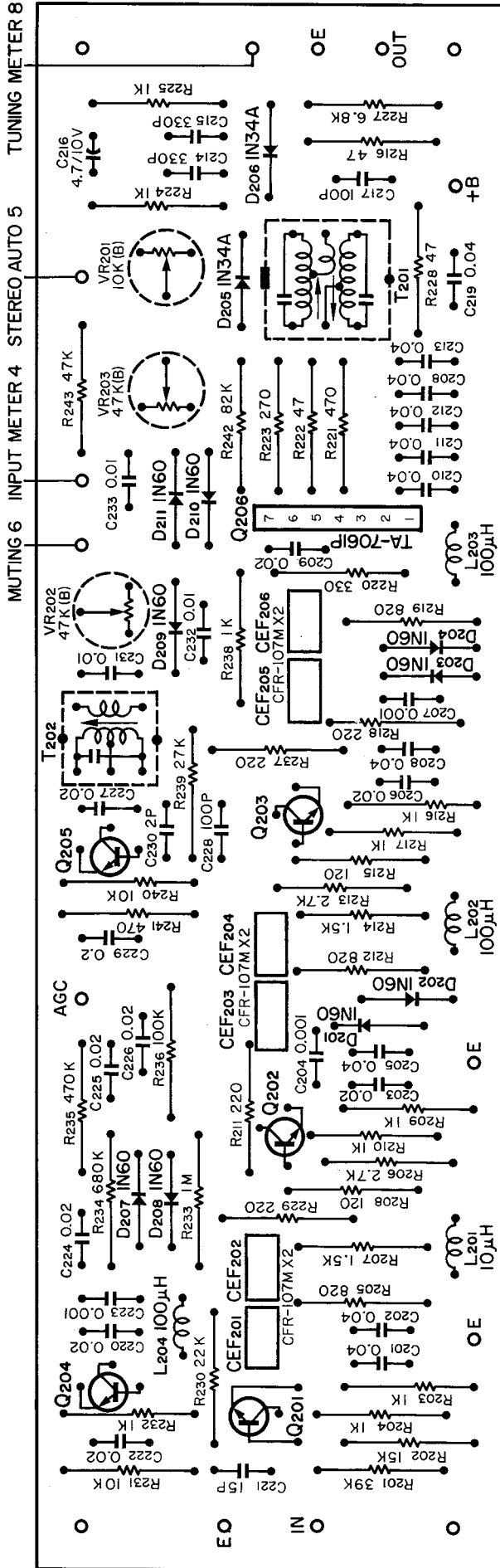

Q201~205 2SC460 (B) N-040  
Q206 TA-7061P







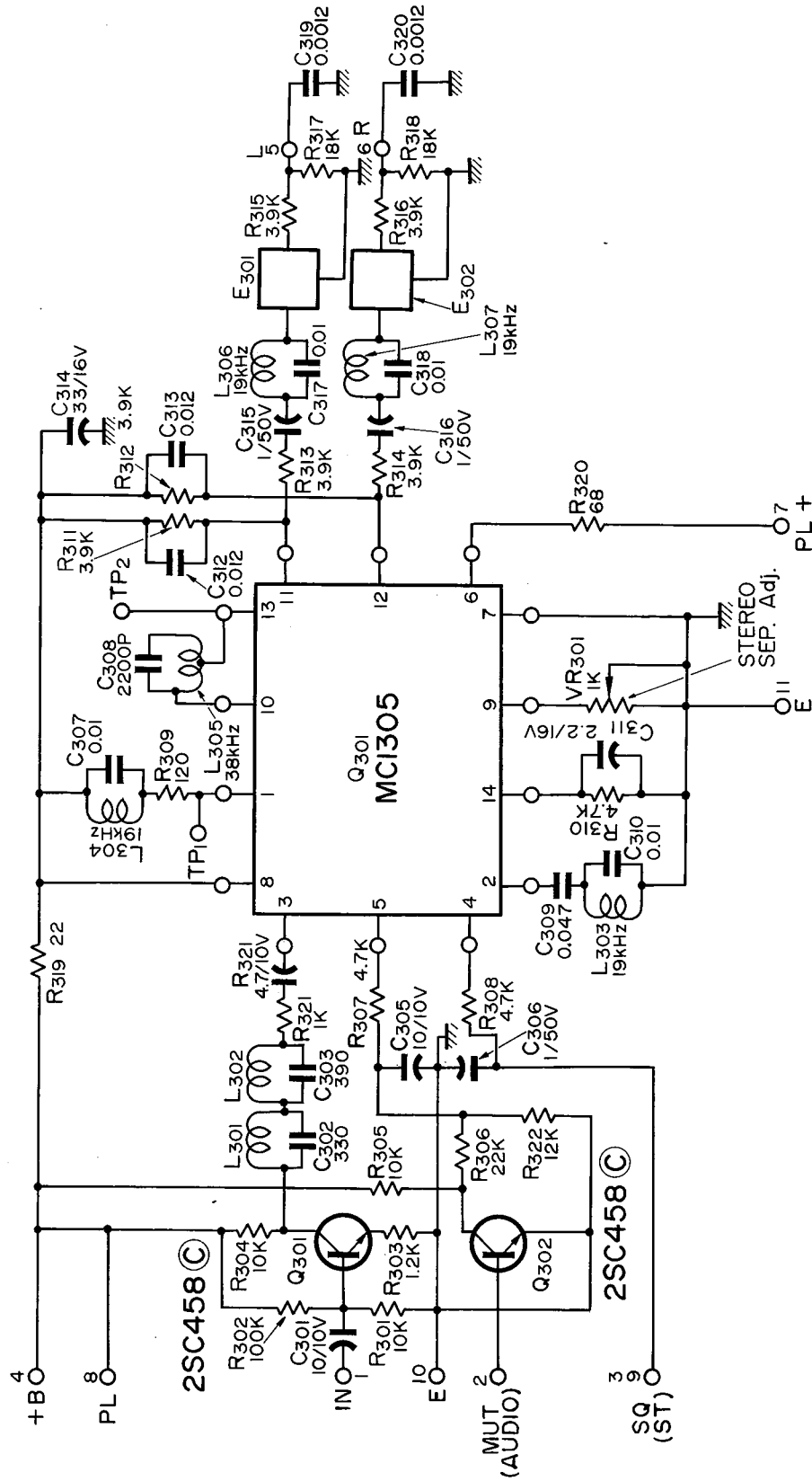

# TEAC AG-7000 SCHEMATIC DIAGRAM FM MPX AMP

APPLICABLE FOR AG 6000 LATE MODEL

# TEAC AG-3000/6000/7000 PC BOARD

## AM TUNER

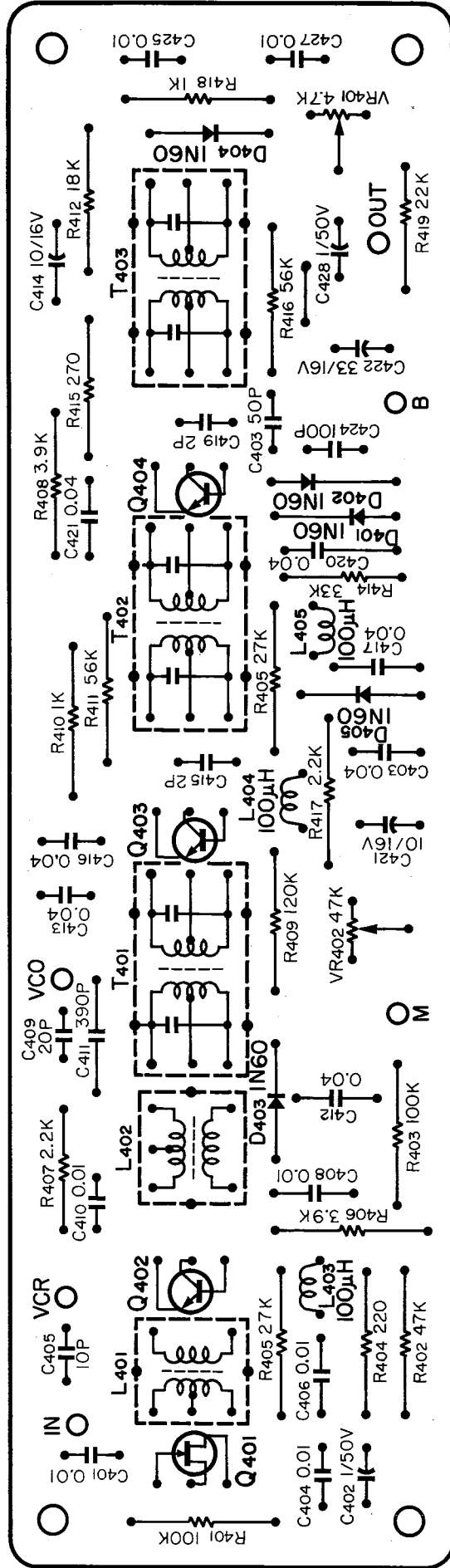

N-0405

Q401 2SK19 (BL)  
Q402~404 2SC372 (Y)

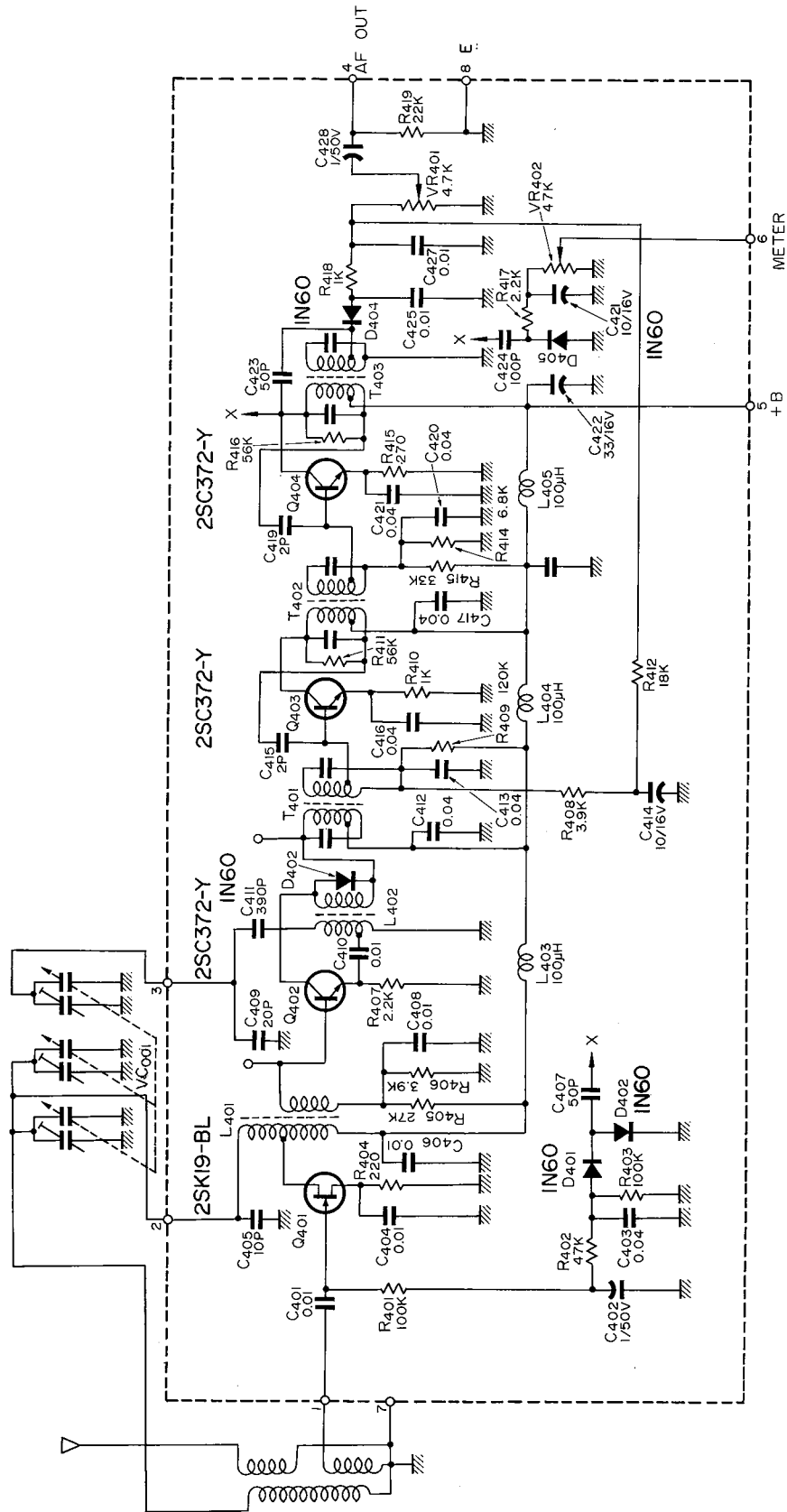

**TEAC AG-3000/6000/7000 SCHEMATIC DIAGRAM**  
**AM TUNER**

TEAC AG-3000/6000/7000 PC BOARD

POWER AMP

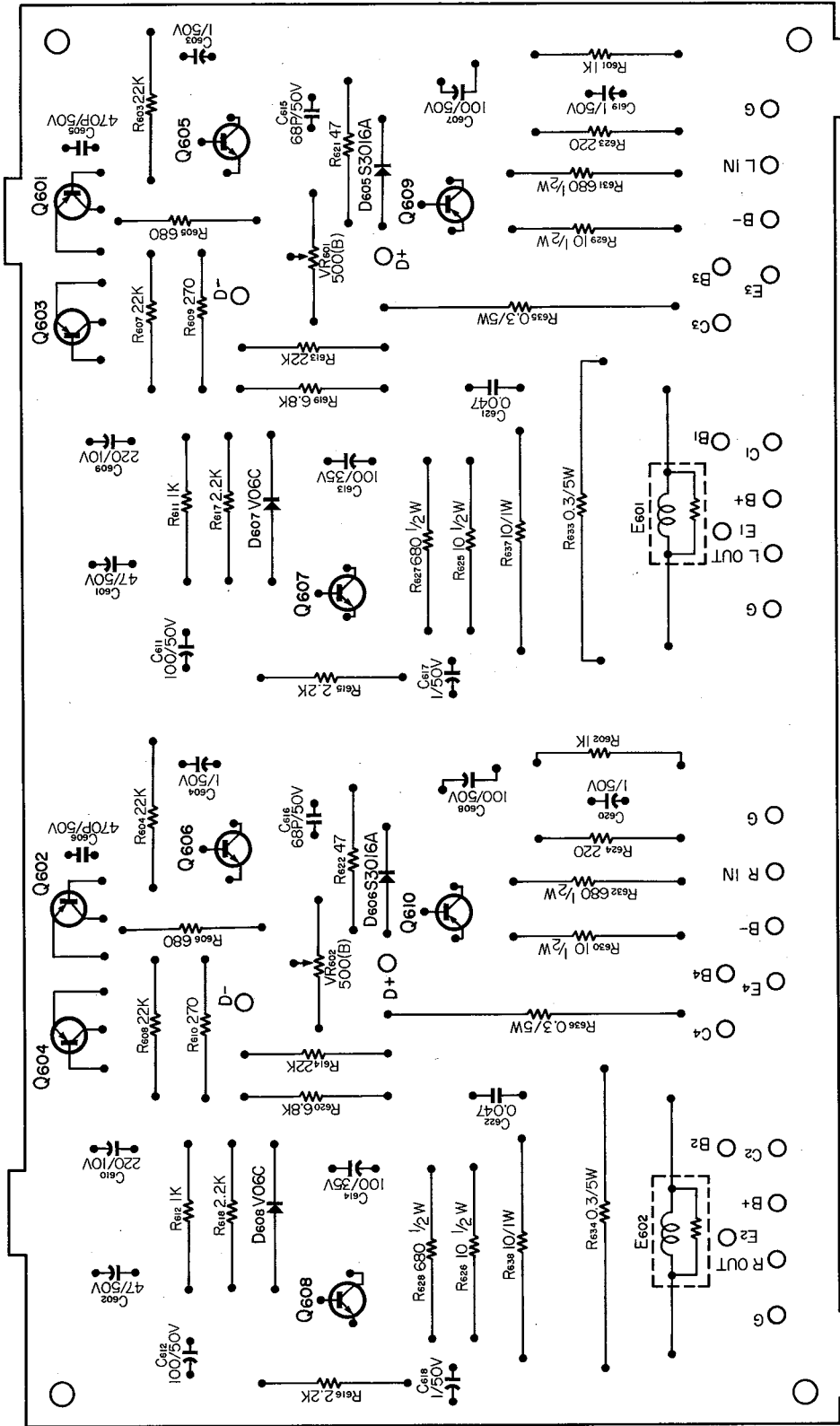

Q601~Q604 2SA561 (Y)  
Q605~Q608 2SC485 (BL)  
Q609~Q610 2SA485 (BL)

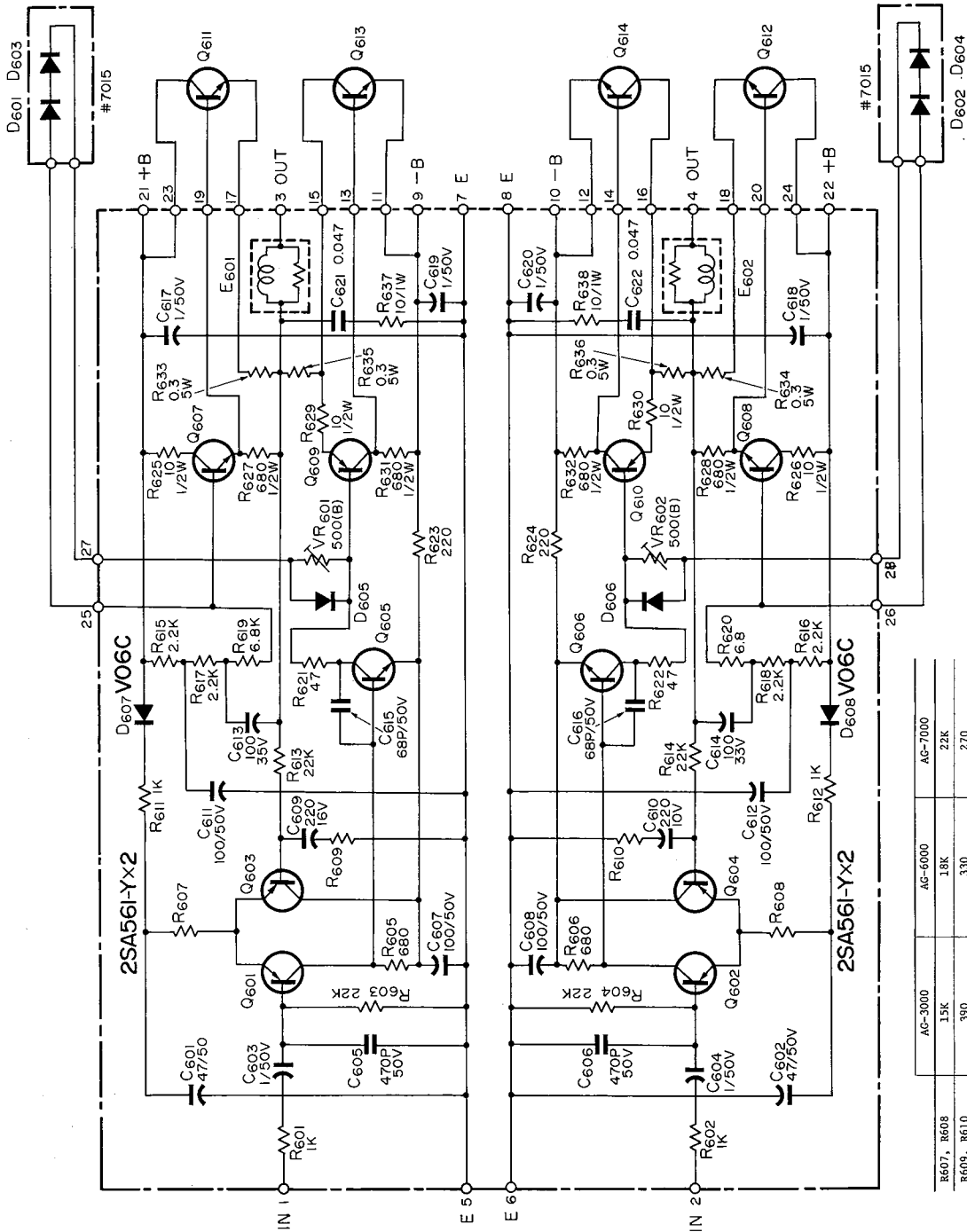

AG-3000	AG-6000	AG-7000
R607, R608	15K	18K
R609, R610	390	270
Q605 - Q608	2SC497-Y	2SC485-BL
Q609, Q610	2SA497-Y	2SA485-BL
Q611 - Q614	2SC1030(B) or (C)	2SC897(B) or (C)
		2SD118-BL

**TEAC AG-3000/6000/7000 SCHEMATIC DIAGRAM**  
**POWER AMP**

TEAC AG-3000/6000/7000 PC BOARD

POWER SUPPLY

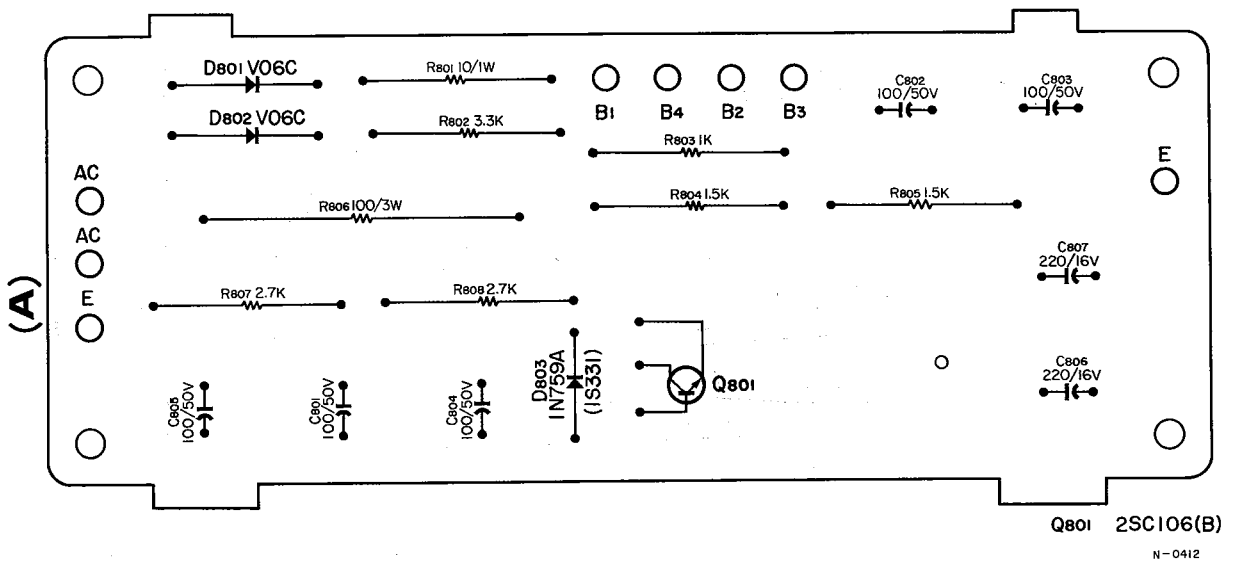
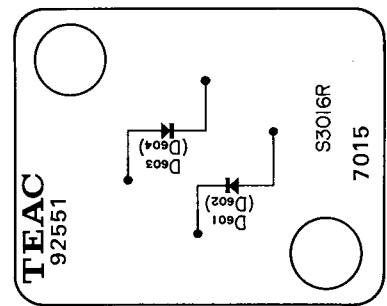
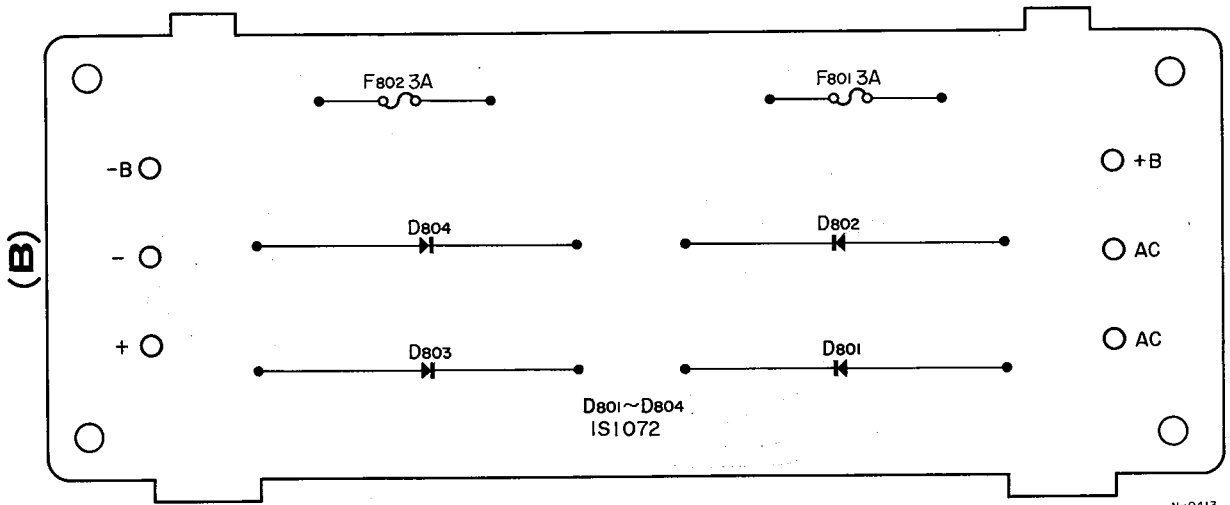





# TEAC AG-3000/6000/7000 PC BOARD PHONO AMP

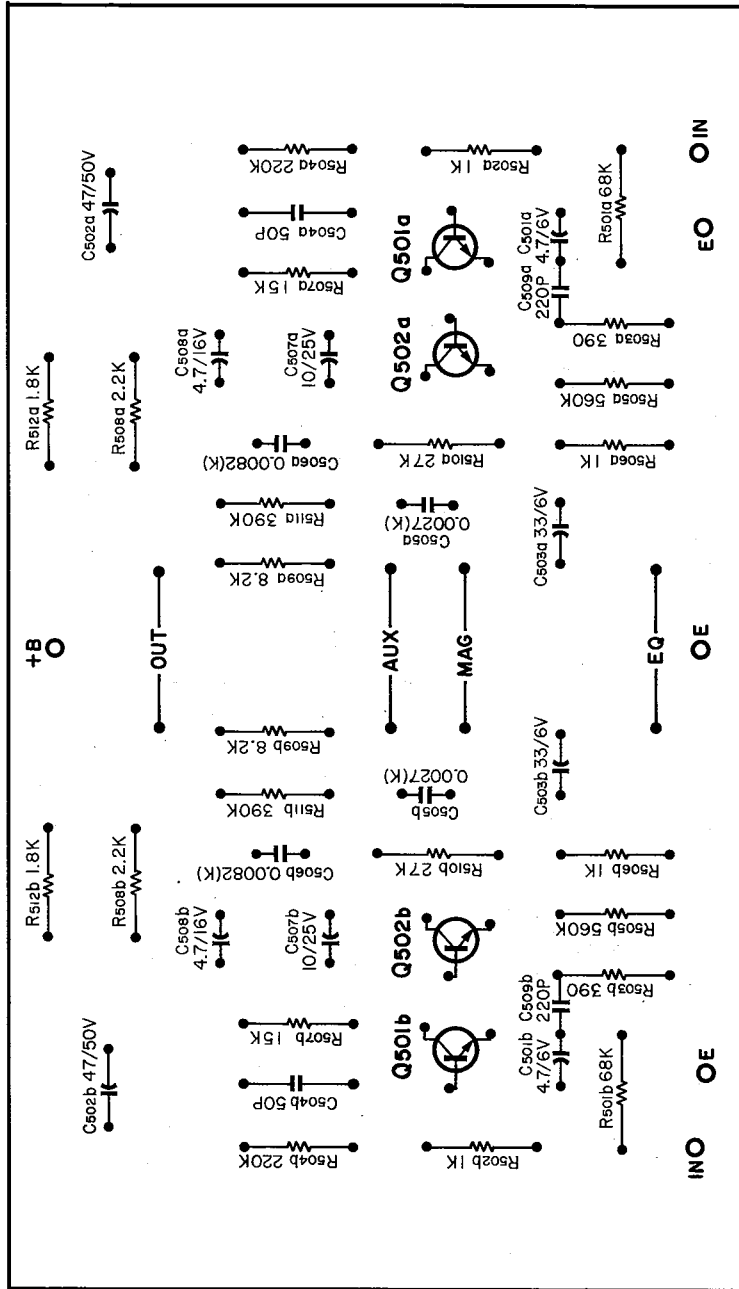

N-0407

Q501a, 502a, 501b, 502b 2SC458 (LGC)

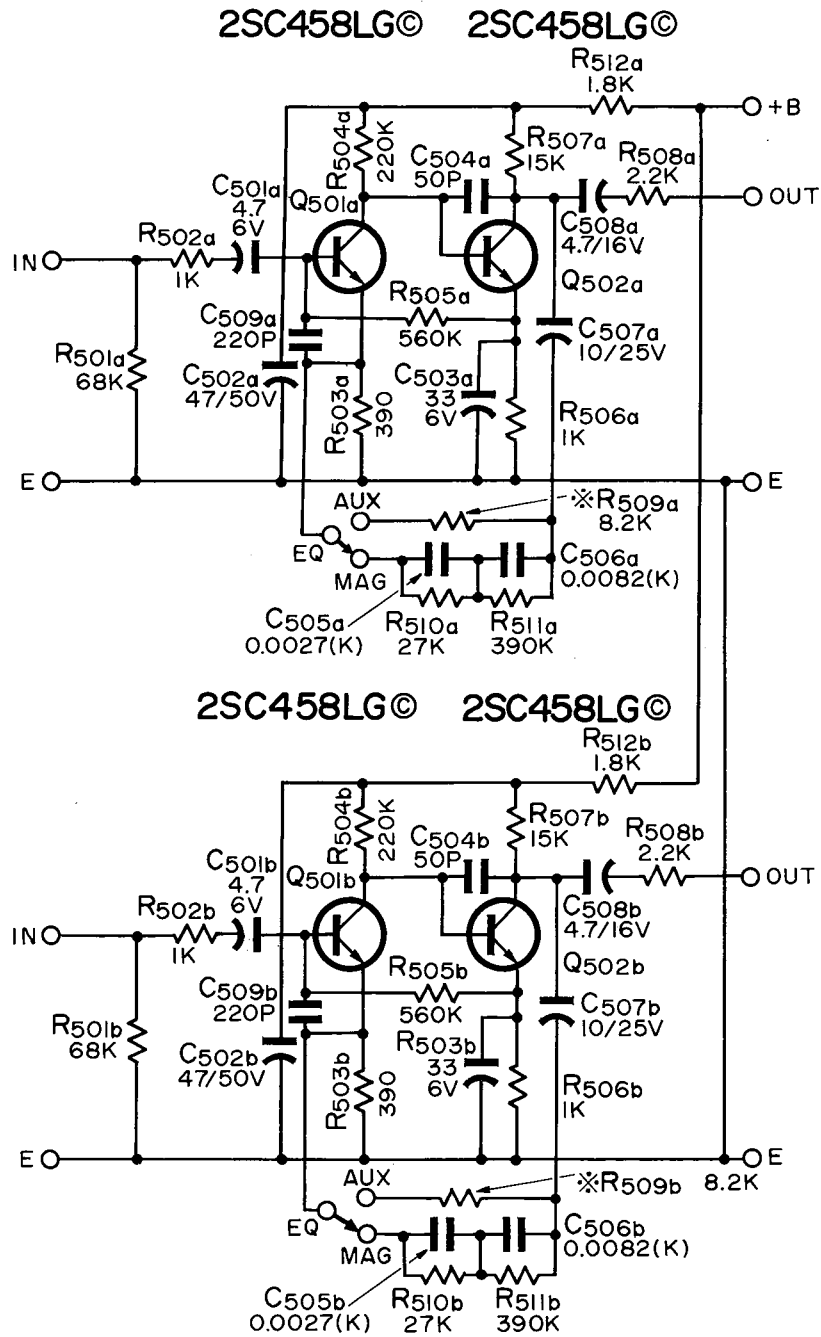

TEAC AG-3000/6000/7000 SCHEMATIC DIAGRAM  
PHONO AMP

TEAC AG-3000/6000/7000 PC BOARD

CONTROL AMP

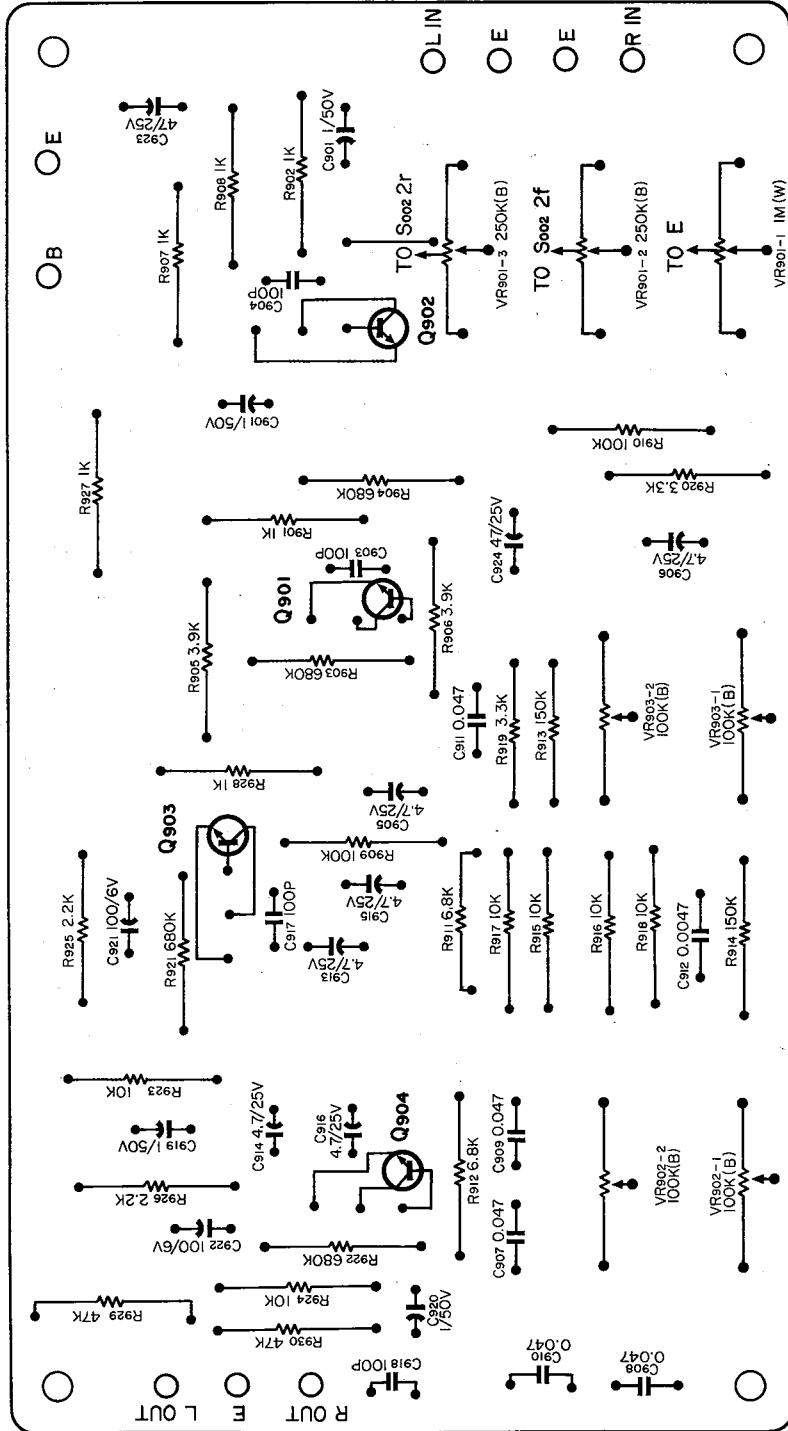

Q901, 903 25C458 (LGC)  
Q902, 904 25C458 (LGC)

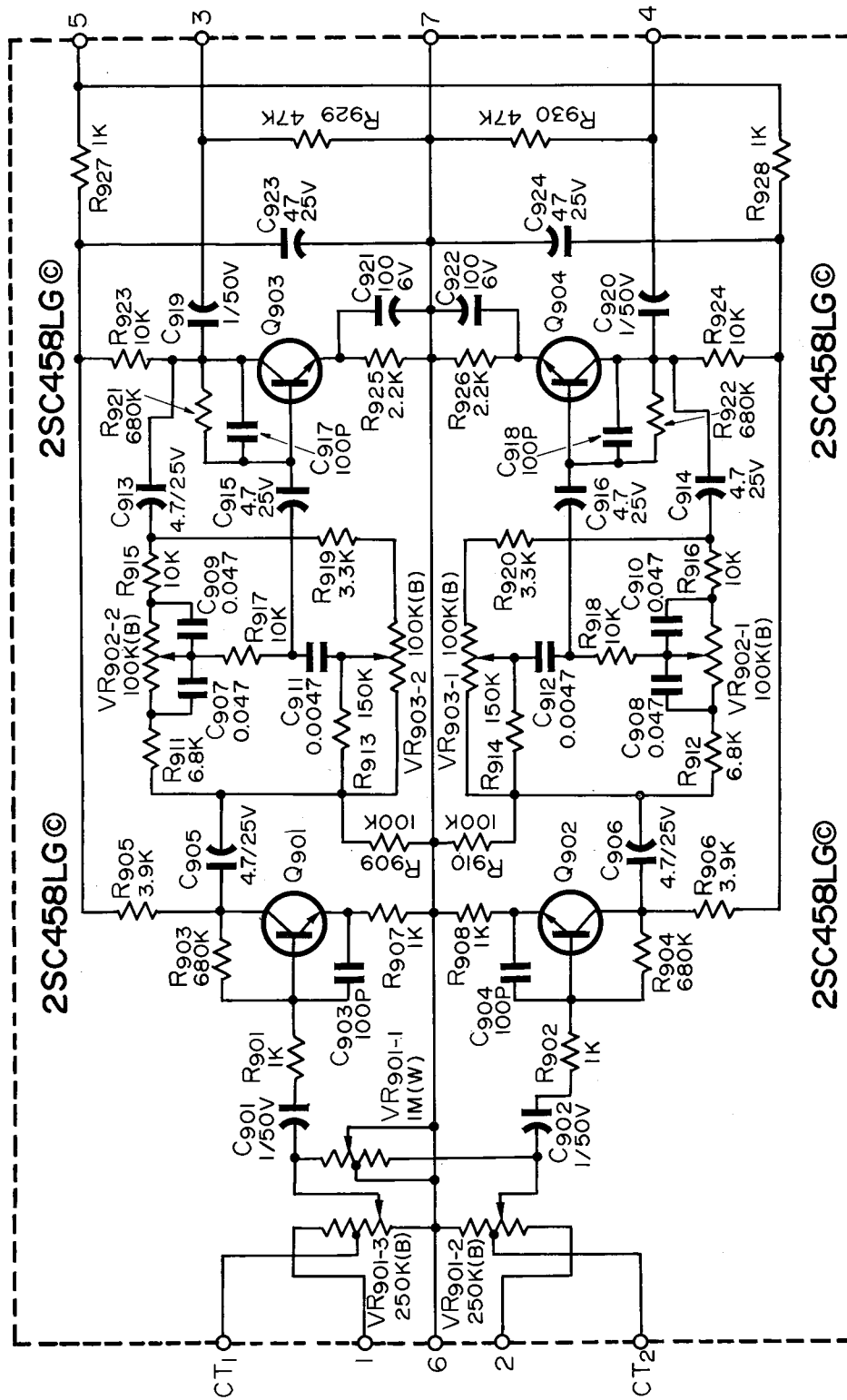

TEAC AG-3000 / 6000 / 7000 SCHEMATIC DIAGRAM  
CONTROL AMP

# TEAC AG-3000 PC BOARD FILTER SWITCH

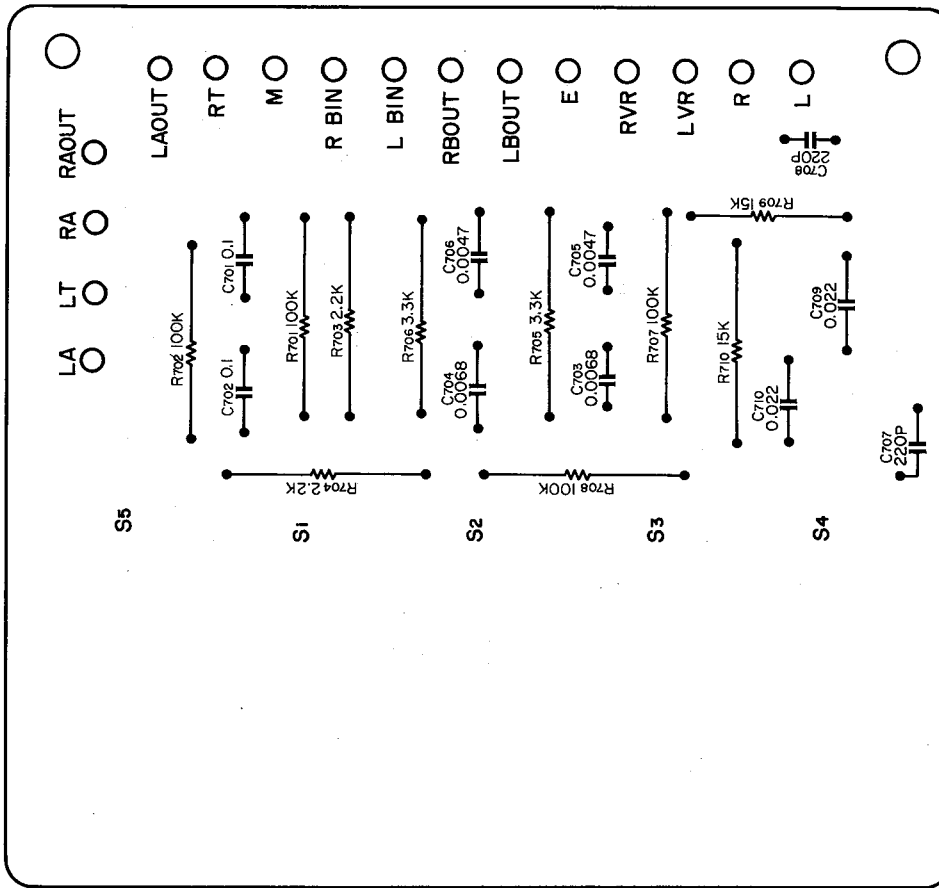

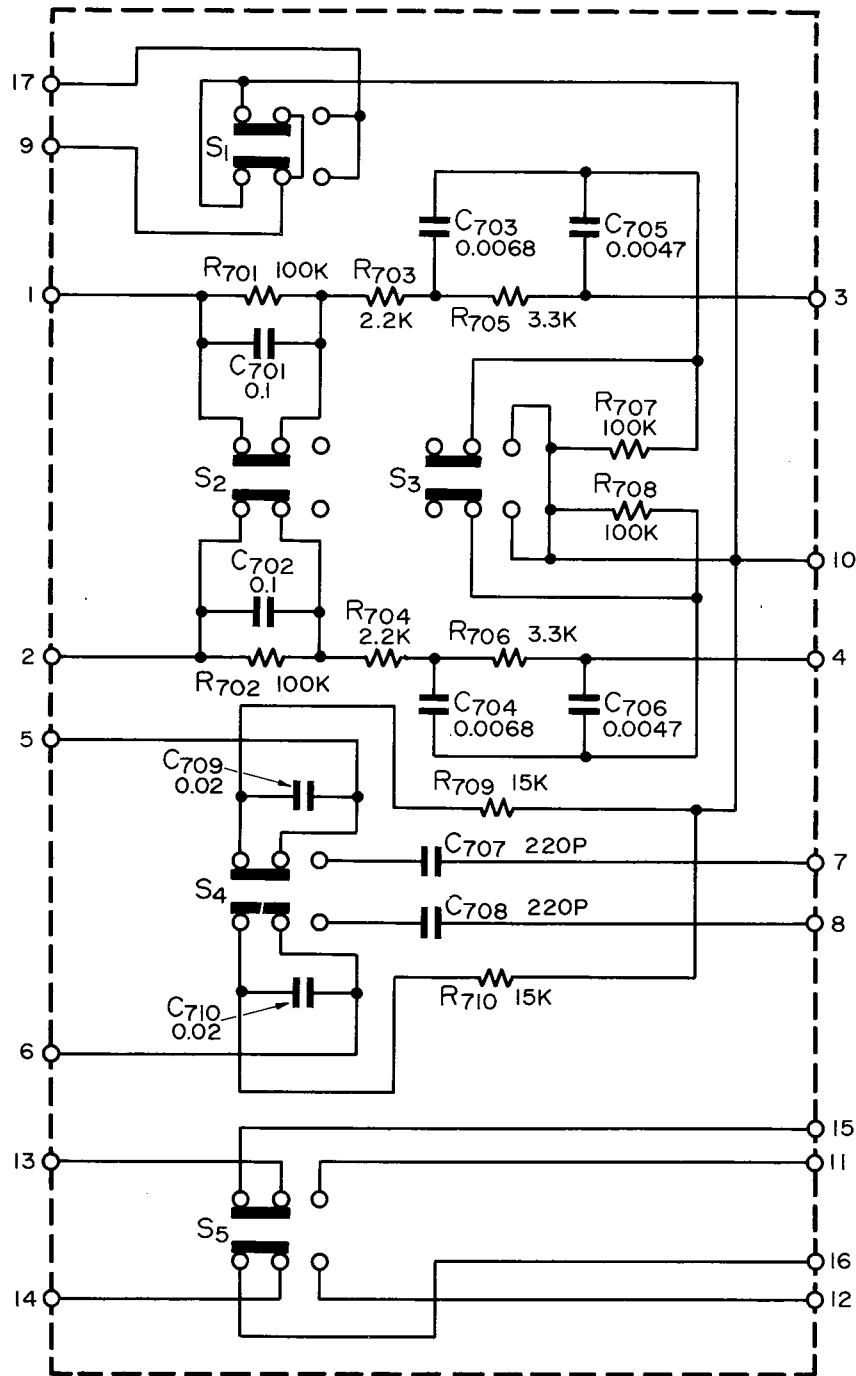

TEAC AG-3000 SCHEMATIC DIAGRAM  
FILTER SWITCH

- S<sub>1</sub> : MUTING
- S<sub>2</sub> : LOW CUT FILTER
- S<sub>3</sub> : HIGH CUT FILTER
- S<sub>4</sub> : LOUDNESS
- S<sub>5</sub> : TAPE MONITOR

**TEAC AG-3000 BLOCK DIAGRAM**

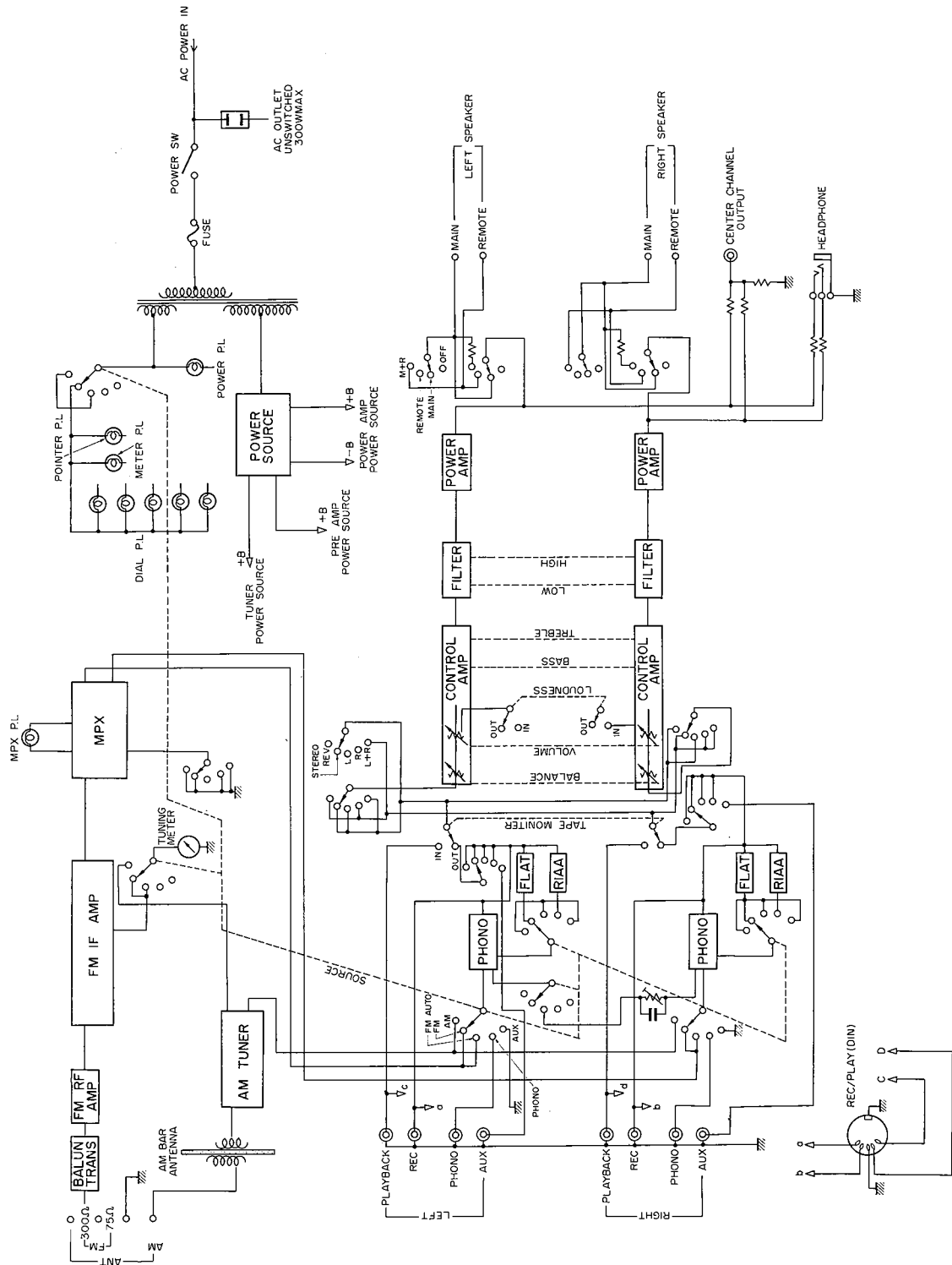



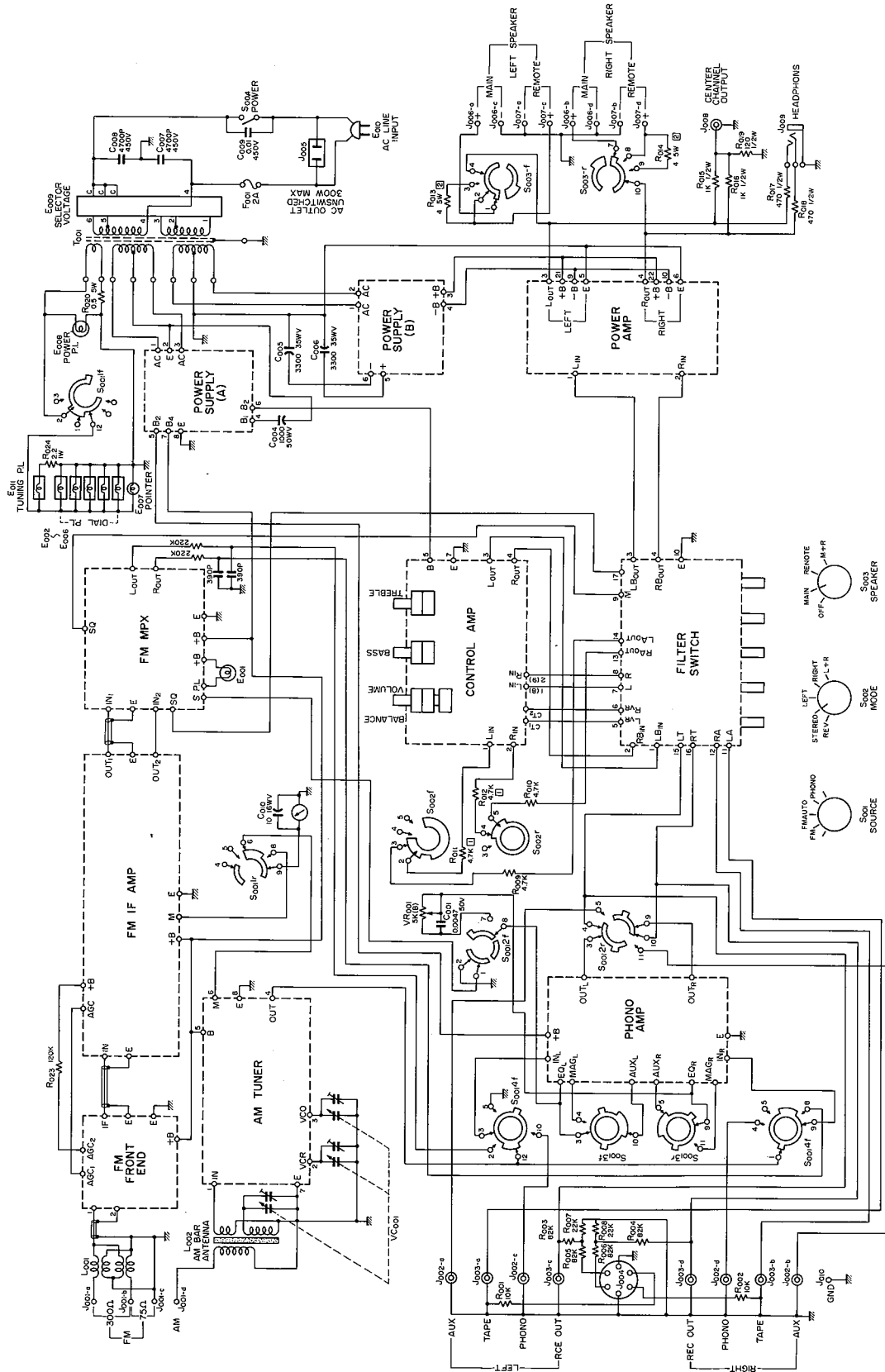

**TEAC AG-3000 SCHEMATIC DIAGRAM**

# TEAC AG-6000 PC BOARD

## FM IF AMP

(EARLY MODEL ONLY)

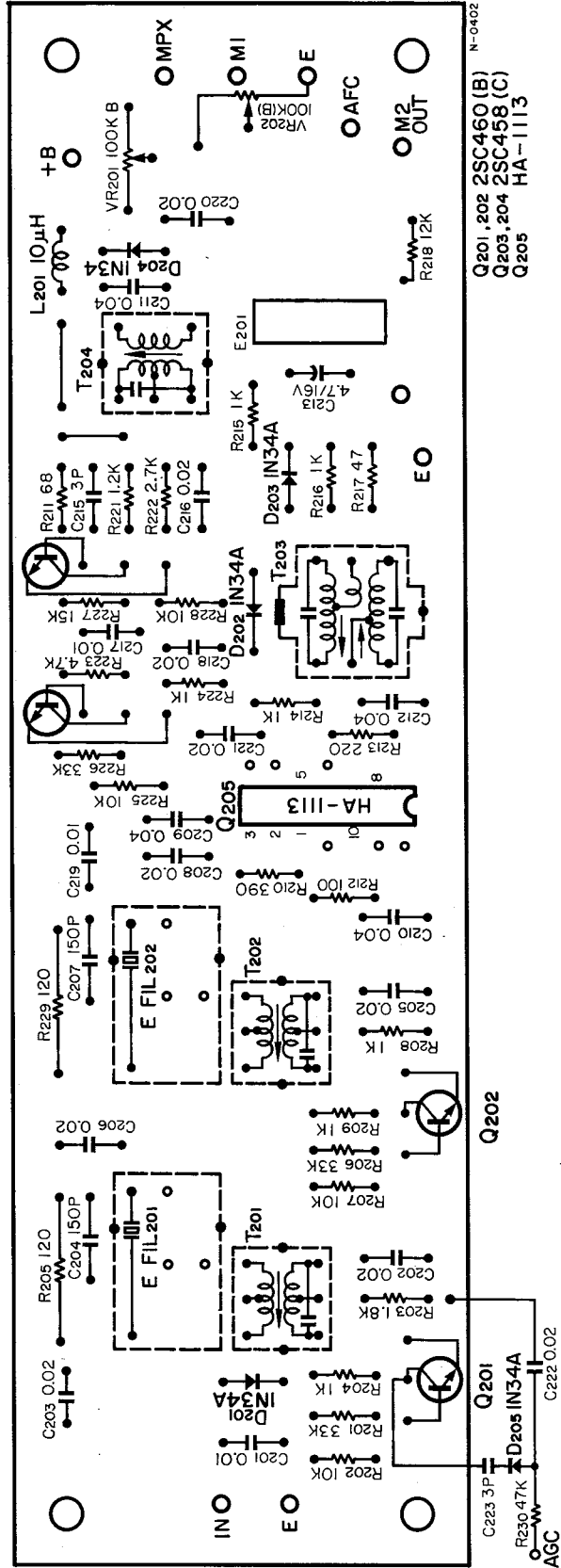

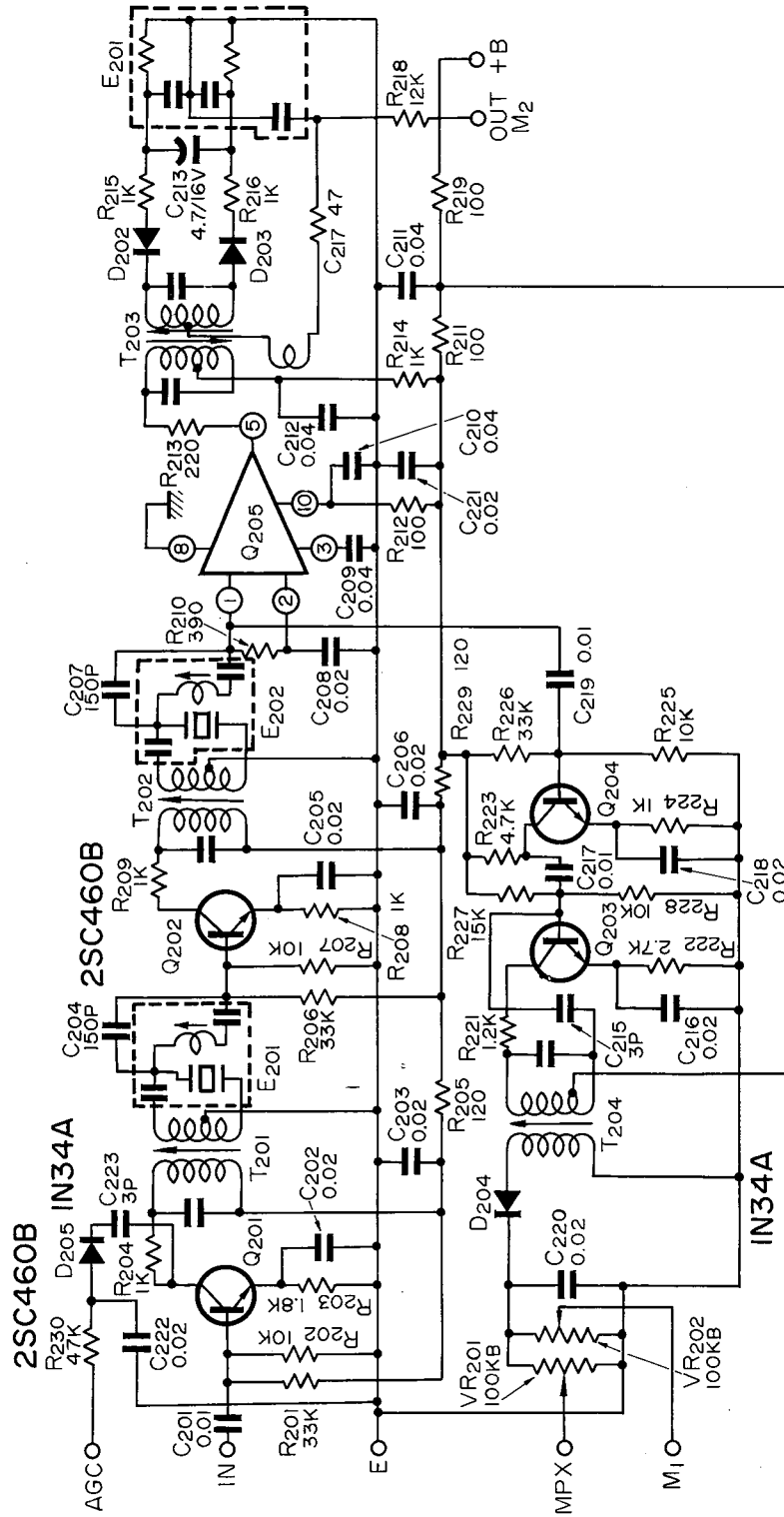

**TEAC AG-6000 SCHEMATIC DIAGRAM**  
**FM IF AMP**  
(EARLY MODEL ONLY)

# TEAC AG-6000/7000 PC BOARD FILTER SWITCH

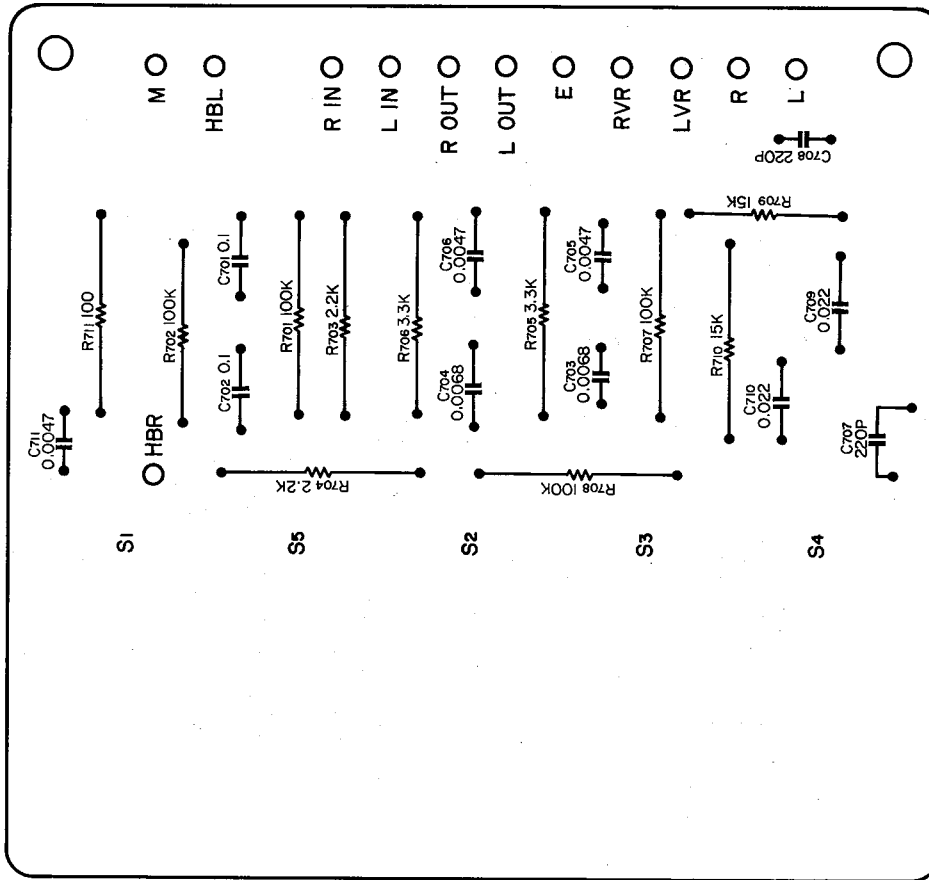

N-0409

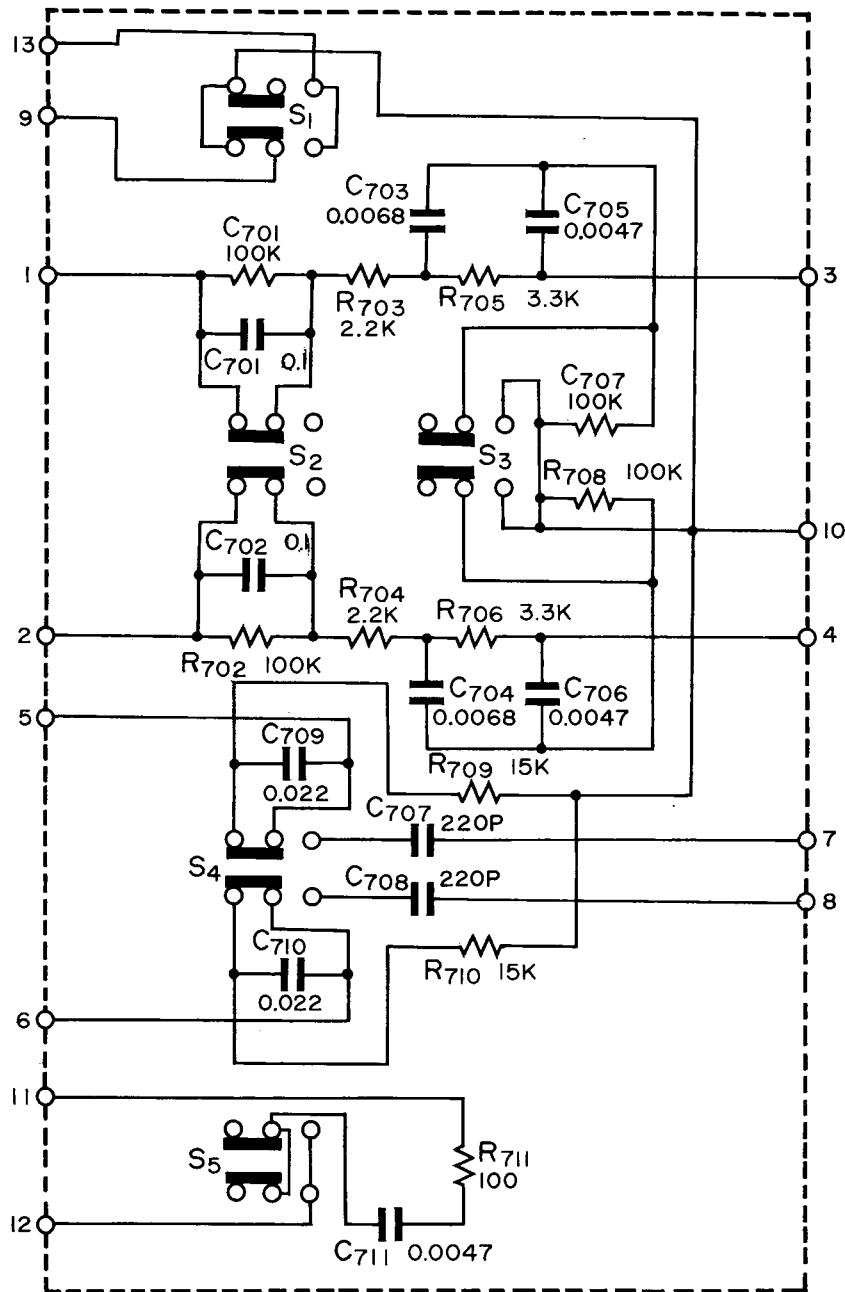

- S<sub>1</sub> MUTING
- S<sub>2</sub> LOW CUT FILTER
- S<sub>3</sub> HIGH CUT FILTER
- S<sub>4</sub> LOUDNESS
- S<sub>5</sub> HIGH BLEND

TEAC AG-6000/7000 SCHEMATIC DIAGRAM  
FILTER SWITCH

**TEAC AG-6000 SCHEMATIC DIAGRAM**

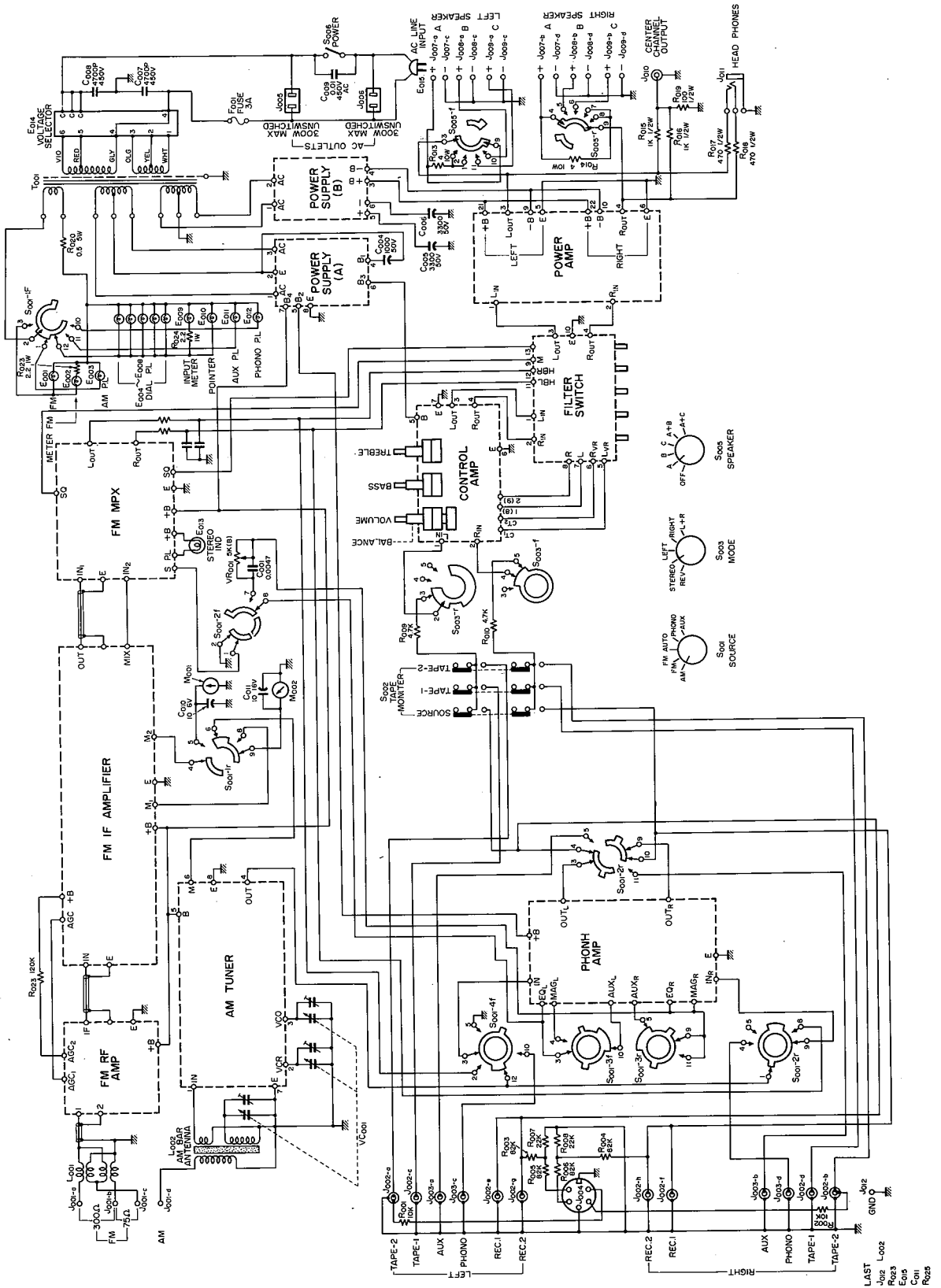

LAST  
J002 L002  
R003  
E005  
C001  
R025







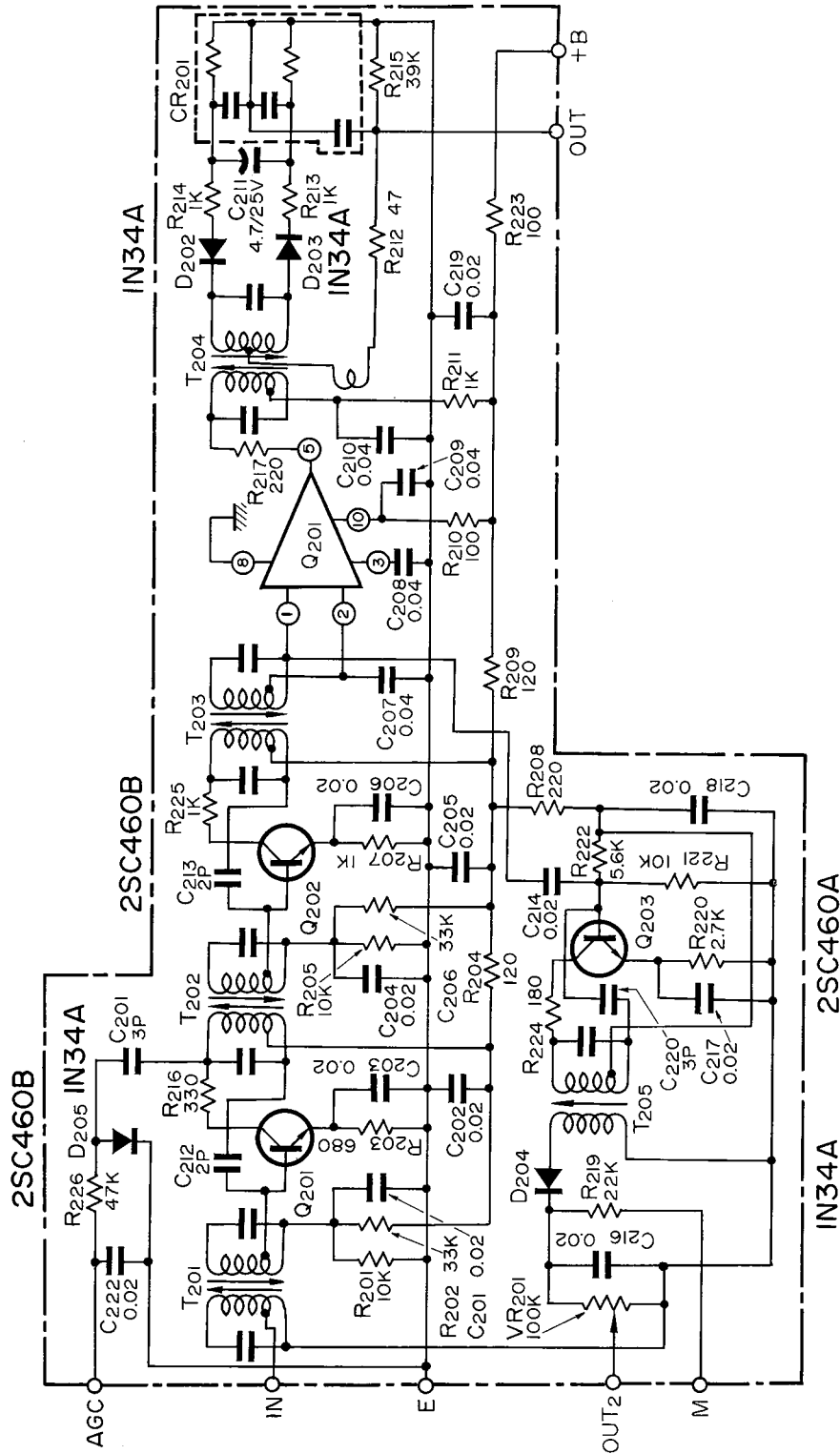

TEAC AG-3000 SCHEMATIC DIAGRAM  
FM IF AMP

# TEAC AG-3000/6000 PC BOARD FM MPX AMP

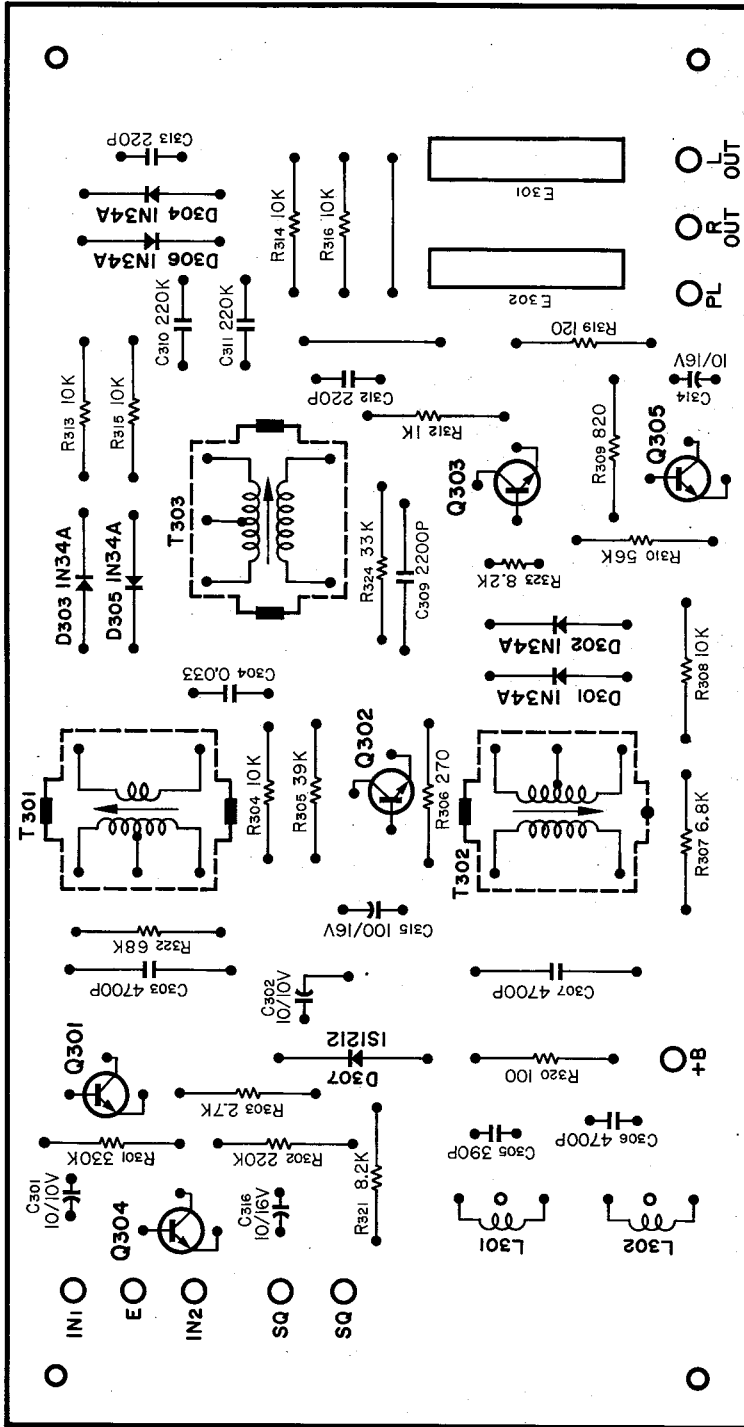

N-0405  
Q301, 303 2SC458 (C)  
Q302 2SC458 (B)  
Q304, 305 2SC458 (D)

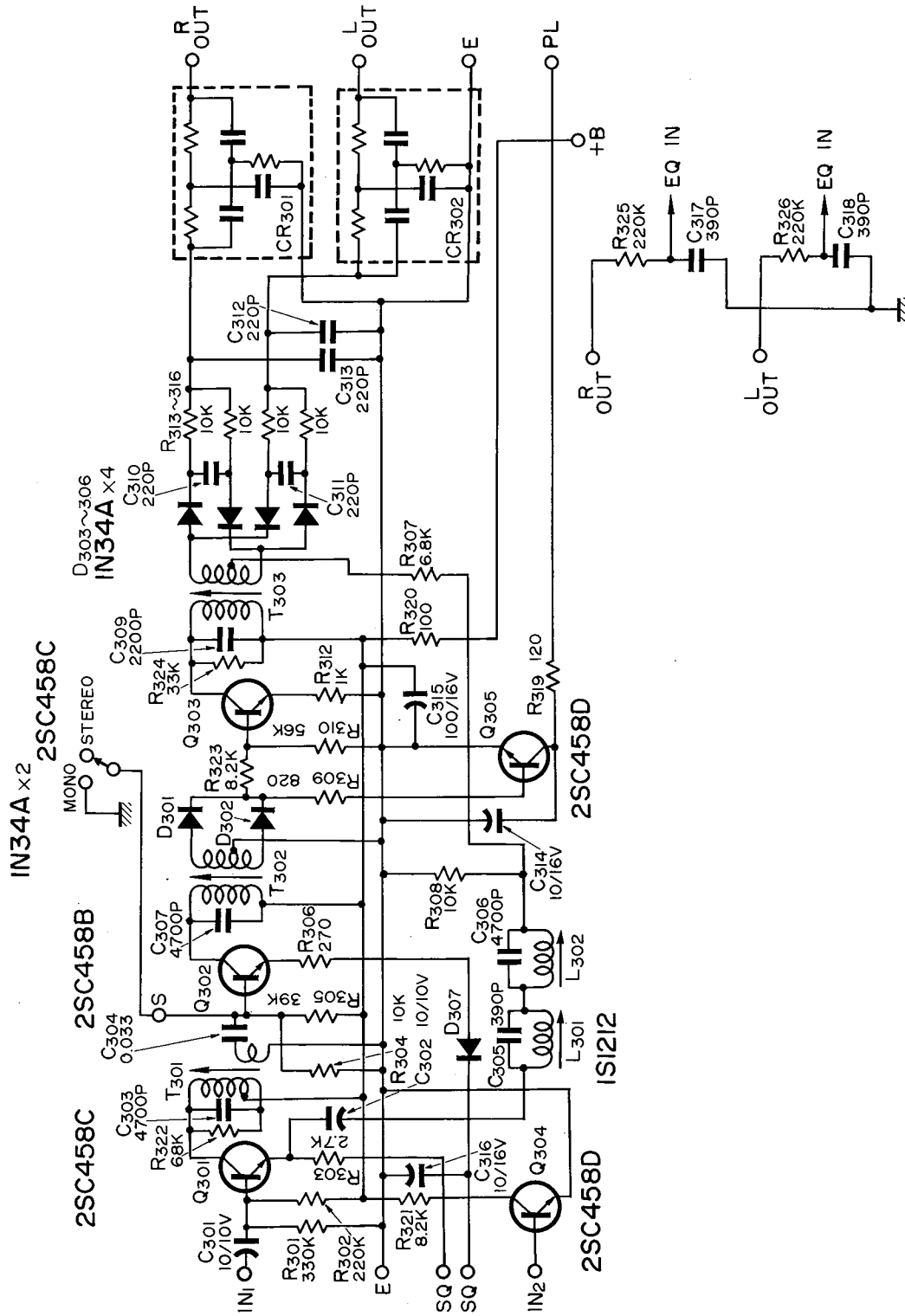

TEAC AG-3000/6000 SCHEMATIC DIAGRAM

FM MPX AMP

AG 6000 EARLY MODEL ONLY