

# TEAC

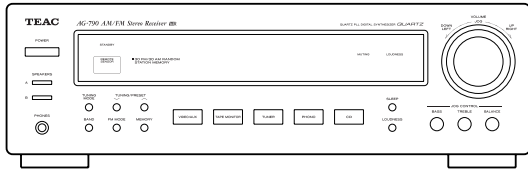

## SERVICE MANUAL

# AG-790

### AM/FM Stereo Receiver

#### CONTENTS

1 SPECIFICATIONS .....	2
2 ADJUSTMENTS AND CHECKS .....	3
3 EXPLODED VIEWS AND PARTS LIST .....	6
4 PC BOARDS AND PARTS LIST .....	8

#### NOTES

- PC boards shown are viewed from parts side.
- The parts with no reference number or no parts number in the exploded views are not supplied.
- As regards the resistors and capacitors, refer to the circuit diagrams contained in this manual.
- ⚠ Parts marked with this sign are safety critical components. They must be replaced with identical components - refer to the appropriate parts list and ensure exact replacement.



## 2 ADJUSTMENTS AND CHECKS

### 2-1 AMPLIFIER SECTION

#### Bias Current Adjustment

1. Turn the unit on, and set the input selector switch to "CD".
2. Set 7VR1 and 7VR2 to the center position.
3. Connect the DC voltmeter as shown below after preheating for 10 minutes, and adjust 7VR2 (Lch) so that the voltage becomes  $3.3 \pm 1.3\text{mV}$ .
4. Adjust 7VR1 (Rch) in the same way.

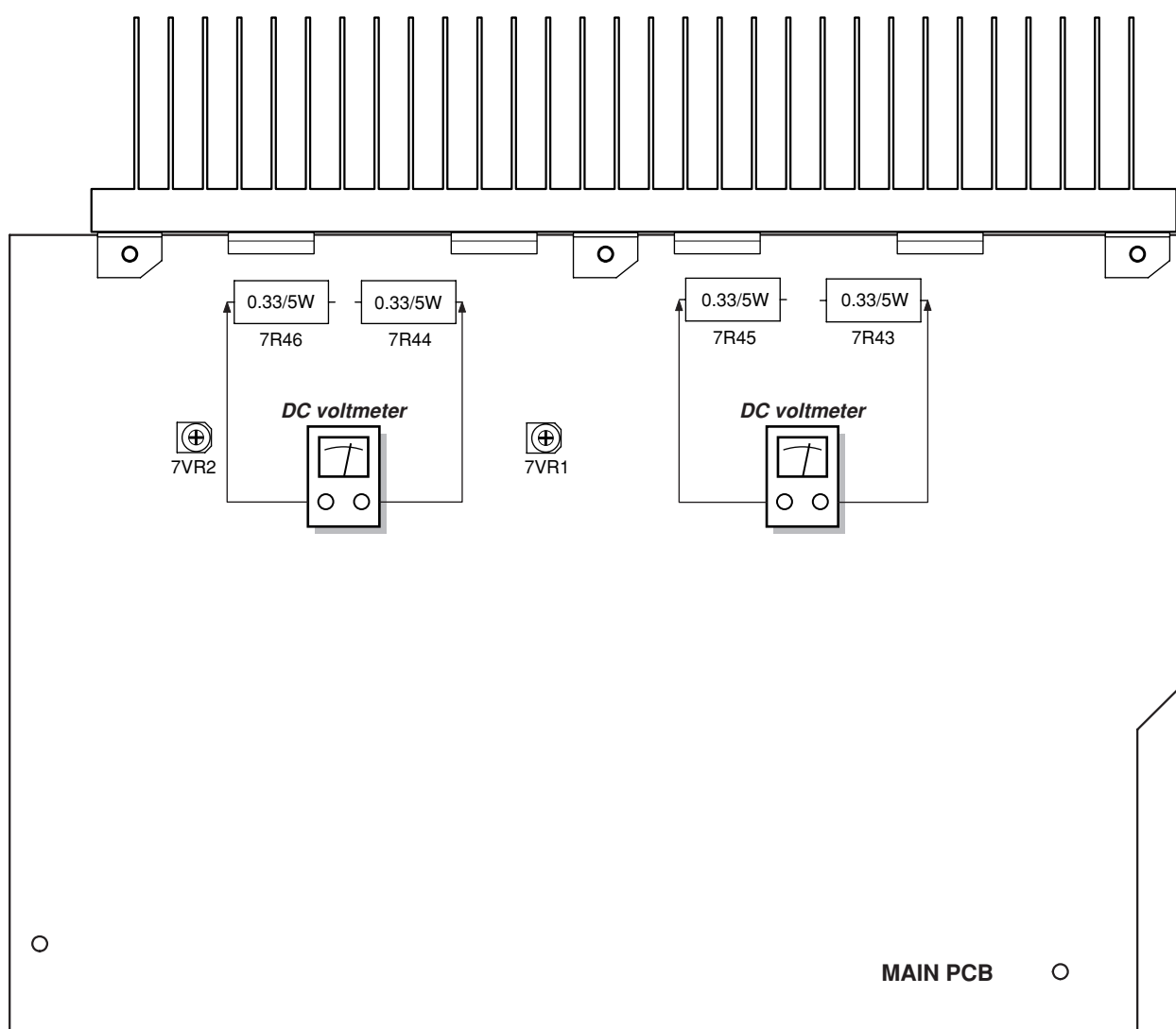

## 2-2 TUNER SECTION

ITEM	SETTING			ADJUSTMENT POINTS	ADJUST
	INPUT	OUTPUT	AG-790		
1. VT Adjust	/	[A] 2R19 (VT) 2J2 (GND)	FM 87.5 MHz	2L3 (3.5T)	DC 1.0±0.05V
			FM 108.0 MHz	Check	DC 8.0±0.5V
			AM 530 kHz	2T2 (RED)	DC 1.1±0.05V
			AM 1720 kHz	Check	≤ 8.0V
2. AM Sensitivity	[B] 600 kHz/1500 kHz 50 dB/m 400 Hz (30 % Mod)	[C] REC OUT	AM 600 kHz	2T1 (BLK)	Max.
			AM 1500 kHz	2TC2	Max.
			After adjusting 2TC2, readjust 2T1 at 600 kHz.		
3. AM IF	[B] 1000 kHz 50 dB/m 400 Hz (30 % Mod)	[C] REC OUT	AM 1000 kHz	2T3 (WHT)	Max.
4. FM Sensitivity	[D] 90 MHz 10~20 dBf 1 kHz (100 % Mod)	[F] REC OUT	FM 90 MHz	2L2 (4.5T)	Max.
5. FM Distortion	[D] 98 MHz 60 dBf 1 kHz (100 % Mod)	[G] REC OUT	FM 98 MHz	2T4 (PINK)	Min. distortion
6. FM Stereo	[D] [E] 98 MHz 60 dBf Stereo signal L-R	[G] REC OUT	FM 98 MHz	2T5, 2T6	Min. distortion

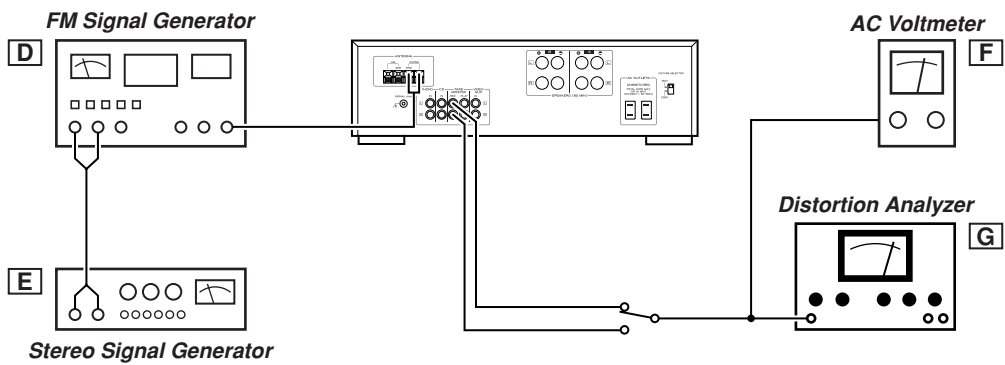
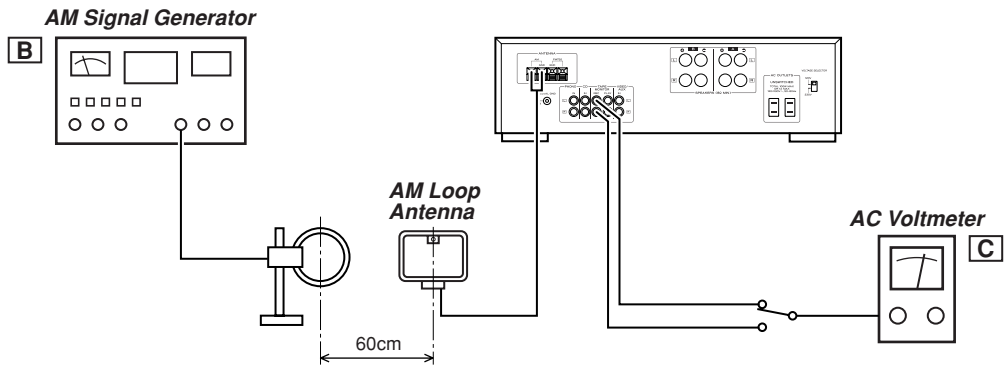
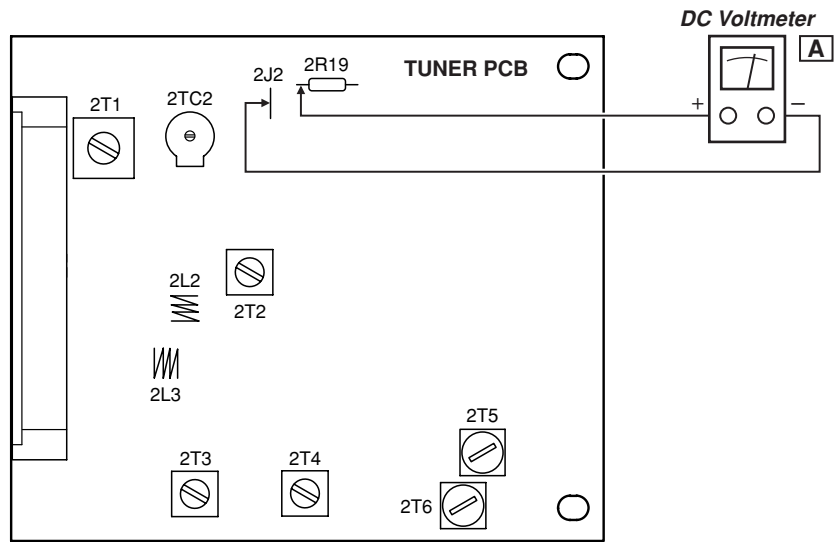

# 3 EXPLODED VIEWS AND PARTS LIST

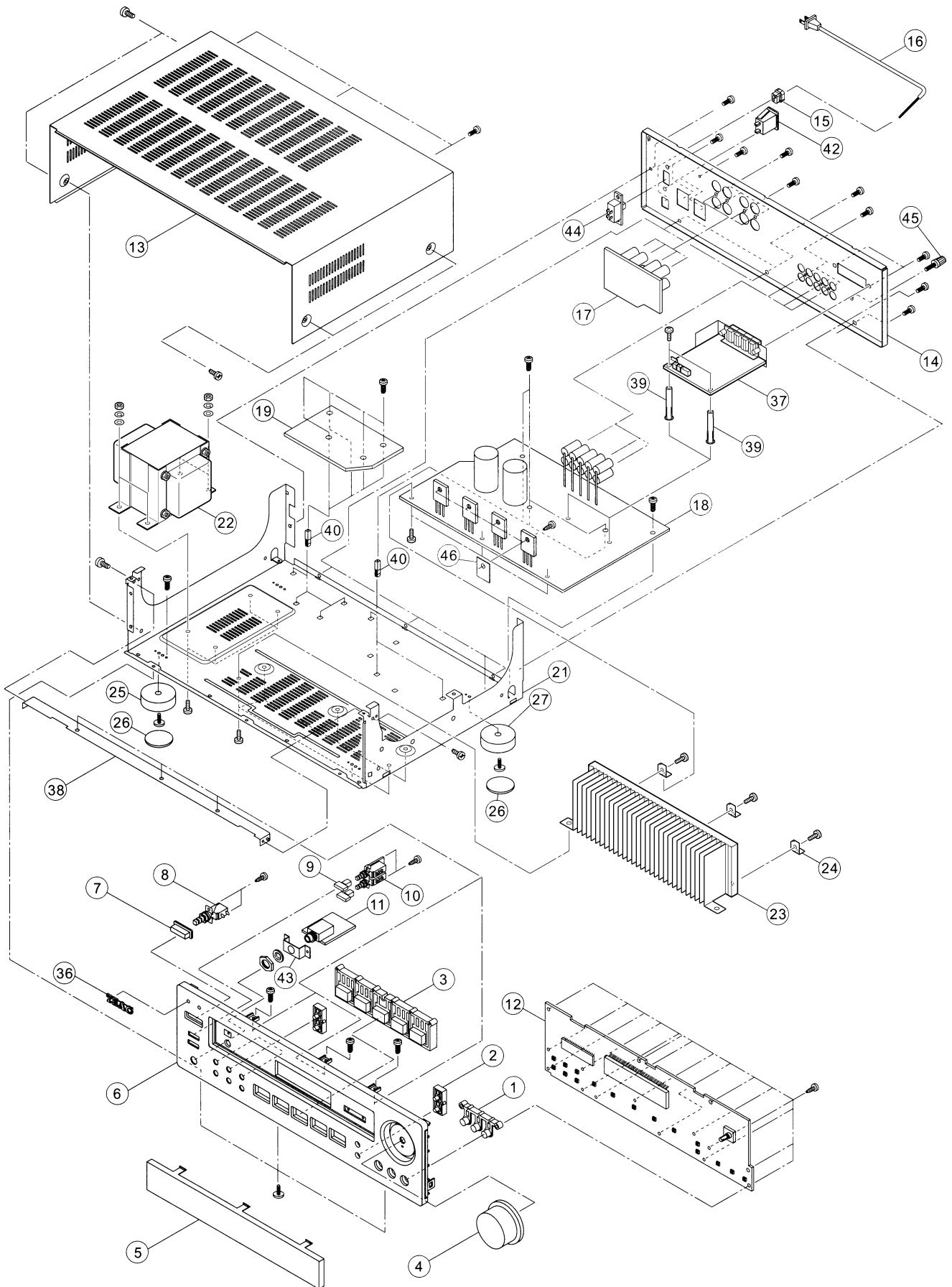

## EXPLODED VIEW LIST

REF. NO.	PARTS NO.	DESCRIPTION	REMARKS
1	9A09760000	TONE KEY	530503500
2	9A09759900	TUNING KEY	530503300
3	9A09759800	FUNCTION KEY	530503400
4	9A09760200	VOLUME KNOB	530503600
5	9A09759700	DISPLAY LENS	510503800
6	9A09759600	PANEL	510503700
7	9A09760100	POWER KNOB	530503200
8	△ 9A06602800	POWER SWITCH	180222501
9	9A09760300	SP KNOB	530503100
10	9A09758660	SP SEL PCB ASSY	037900303
11	9A09758160	HEADPHONE PCB ASSY	037900405
12	9A09755060	FRONT PCB ASSY	037900105
13	9A09760700	TOP COVER	520505400
14	9A09760600	REAR COVER	520505300
15	△ 9A06900600	CORD BUSHING	550011700
16	△ 9A09580200	AC POWER CORD	210183011
17	9A09759060	SP JACK PCB ASSY	037900605
18	9A09752260	MAIN PCB ASSY	037900206
19	9A09756560	POWER PCB ASSY	037900505
21	9A09760500	BOTTOM COVER	520505200
22	△ 9A09759500	POWER TRANSFORMER	159642022
23	9A09760900	HEAT SINK	560502200
24	9A06901200	H/S BRACKET	540082800
25	9A06536400	LEG (GOLD)	540082601
26	9A09581500	RUBBER PAD	540503600
27	9A06536300	LEG (BLACK)	540082600
36	9A06900700	NAME PLATE	510104300
37	9A09757660	TUNER PCB ASSY	033700305
38	9A09760800	BRACKET	520505500
39	9A09591600	PCB SUPPORT	550505200
40	9A09760400	PCB SUPPORT	550505300
42	△ 9A06602900	AC SOCKET	26CS18401
43	9A09758500	HEADPHONE JACK HOLDER	550505400
44	△ 9A09759400	VOLTAGE SWITCH	180222902
45	9A06904300	GND TERMINAL, M3	320018601
46	9A09592000	SILICON RUBBER, T0-3P2	322228370

## INCLUDED ACCESSORIES

REF. NO.	PARTS NO.	DESCRIPTION	REMARKS
	9A09551200	OWNER'S MANUAL, EFSP	600520225
	9A09763000	REMOTE CONTROL UNIT, UR-420	500079000
	9A06902500	FM ANT	59W360100
	9A06902600	AM ANT	59W360200





**FRONT PCB**

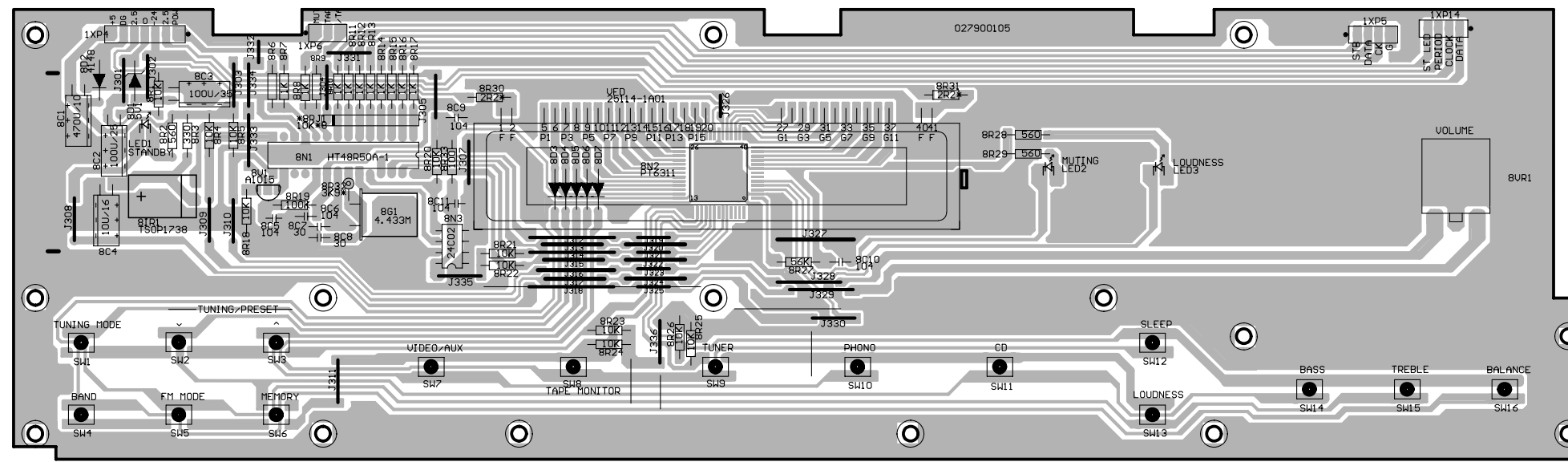

**HEADPHONE PCB**

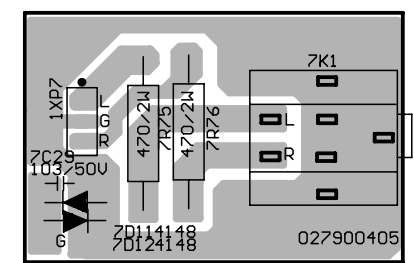

**SP SEL PCB**

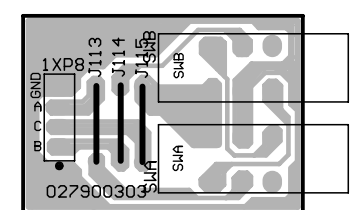

**TUNER PCB**

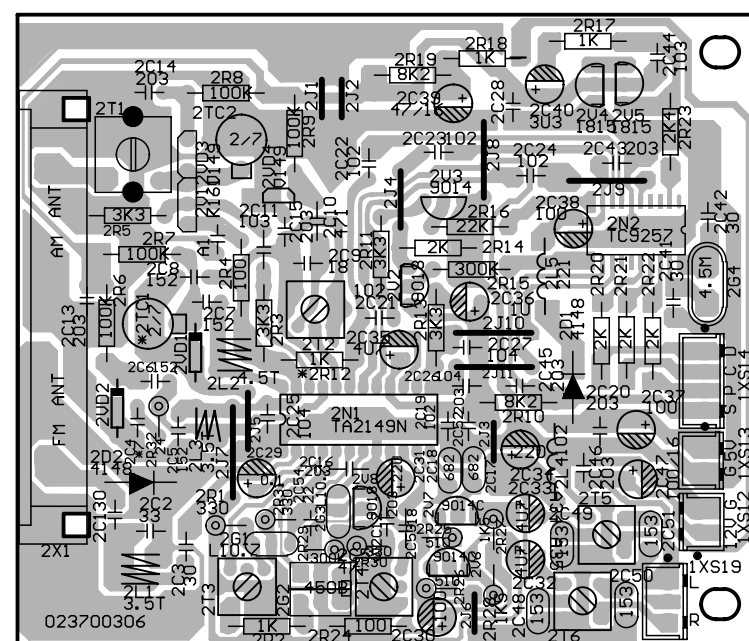

**SP JACK PCB**

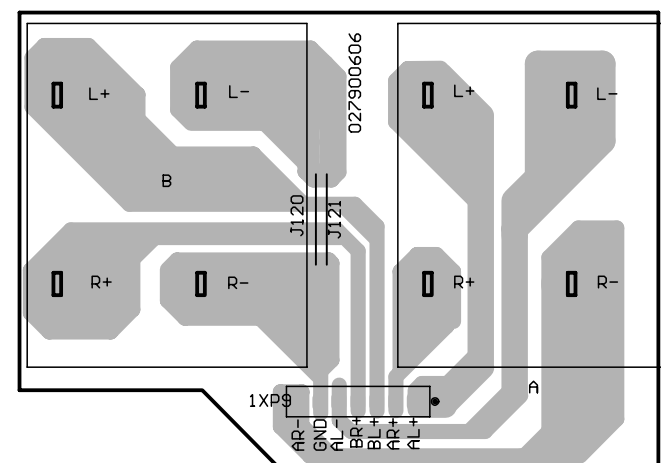

**POWER PCB**

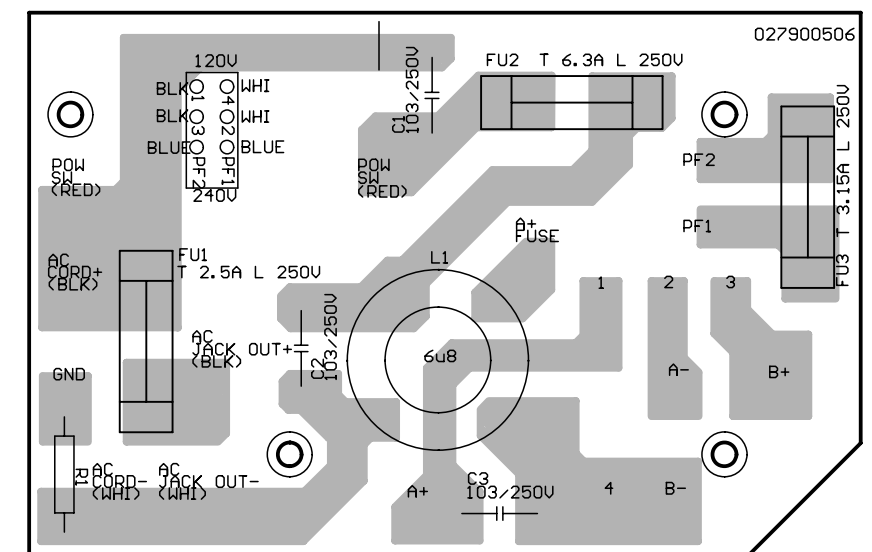

## MAIN PCB ASSY

REF. NO.	PARTS NO.	DESCRIPTION
	9A09752260	MAIN PCB ASSY
	9A09752300	MAIN PCB
	9A06896100	FUSE CLIP
	9A09754600	RCA JACK, RCA602
	9A09754700	RCA JACK, RCA402
	9A09754800	WAFER, 3P
	9A09754900	WAFER, 5P
1C1	△ 9A09586700	C, ELEC 35V 100UF M
1C4-5	△ 9A09586600	C, ELEC 25V 2200UF M
1C12	△ 9A09586500	C, ELEC 25V 100UF M
1C14-15	△ 9A09752500	C, ELEC 70V 8200UF M
1D1-8	△ 9A09589300	DIODE, IN4004
1D9-12	△ 9A09753100	DIODE, 6A10
1D13-14	9A09589500	DIODE, IN4148
1D15-18	△ 9A09589300	DIODE, IN4004
1D19-22	9A09589500	DIODE, IN4148
1D23	9A09589100	DIODE, ZENER 24V 1W
1FU1-2	△ 9A09753200	FUSE, 6.3A 250V SLOW BLOW
1FU3-4	△ 9A09753300	FUSE, 2A 250V SLOW BLOW
1N1	△ 9A09590800	IC, L7812CV
1N2	△ 9A09590900	IC, L7912CV
1N3	△ 9A09590700	IC, L7805CV
1N4	△ 9A09753400	IC, L7809CV
3D1	9A09588800	DIODE, ZENER 6V8 1/2W
3N1	9A09753500	IC, TC9421
3N2	9A09590500	IC, TC4066BP
3V1-2	9A09589600	TR, 2SC1815GR
4N1	9A09590600	IC, JRC4560D
5N1	9A09590600	IC, JRC4560D
7C28	△ 9A09587100	C, ELEC 63V 47UF M
7D1-4	9A09589000	DIODE, ZENER 24V 1/2W
7D5-6	9A09589500	DIODE, IN4148
7D7	9A09589200	DIODE, ZENER 30V 1/2W
7D8	9A09589500	DIODE, IN4148
7D9	9A09588900	DIODE, ZENER 12V 1/2W
7L1-2	9A09591000	COIL, SPRING 1.5UH
7R25-28	△ 9A06889900	R, 1/2W 3.3K
7R43-46	△ 9A09753600	R, CEMENT 5W R33 J
7R61-62	△ 9A09585400	R, 2W 6R1 J
7R68	△ 9A06889900	R, 1/2W 3.3K
7R70	△ 9A07127500	R, 2W 47 FMO
7R77-78	△ 9A09585500	R, 2W 10 J
7V1-4	9A09589700	TR, 2N5551
7V5-10	9A09589800	TR, 2N5401
7V11-14	9A09589700	TR, 2N5551
7V15-16	9A09753800	TR, 2SD669A
7V17-18	9A09753900	TR, 2SB649A
7V19-20	△ 9A09754000	TR, 2SC5200-0
7V21-22	△ 9A09754100	TR, 2SA1943-0
7V23-24	9A09589700	TR, 2N5551
7V25	9A09589800	TR, 2N5401
7V26-29	9A09590100	TR, 2SC8050D
7VR1-2	9A09585700	VR, SEMI-FIXED 300 J
RELA-D	9A09591100	RELAY, 12V 5A

## FRONT PCB ASSY

REF. NO.	PARTS NO.	DESCRIPTION
	9A09755060	FRONT PCB ASSY
	9A09755100	FRONT PCB
	9A09756400	VFD DISPLAY
8D1	9A09592400	DIODE, ZENER 5V1 1/2W
8D2-7	9A09589500	DIODE, IN4148
8G1	9A09592800	OSC, CRYSTAL 4.433M
8IR1	9A09755300	INFRARED RECEIVER, SM0038
8N1	9A09755400	IC, HT48R50A-1
8N2	9A09755500	IC, PT6311
8N3	9A09592600	IC, HT24LC02
8V1	9A09755700	TR, 2SA1015GR
8VR1	9A09755800	ENCODER, R162EC-D1-20F-24C
LED1-3	9A09755900	LED, M3 RED
SW1-16	9A09593100	SW, TACT

## TUNER PCB ASSY

REF. NO.	PARTS NO.	DESCRIPTION
	9A09757660	TUNER PCB ASSY
	9A09625000	TUNER PCB
	9A09625100	TUNER SHIELD CASE
2D1-2	9A09589500	DIODE, IN4148
2G1	9A09622100	FILTER, CERAMIC L10.7MS2 R
2G2	9A09622200	FILTER, CERAMIC SFU450B
2G3	9A09622100	FILTER, CERAMIC L10.7MS2 R
2G4	9A09622300	OSC, CRYSTAL 4.5MHZ
2L1	9A09622400	COIL, SPRING 3.5T M4.5
2L2	9A09622500	COIL, SPRING 4.5T M3.5
2L3	9A09622600	COIL, SPRING 3.5T M3.5
2L4	9A09622700	INDUCTOR, AL0410 102
2L5	9A09622800	INDUCTOR, AL0410 221
2N1	9A09622900	IC, TA2149N
2N2	9A09623000	IC, TC9257F
2T1	9A09623800	IFT, AM RF 10B (BLK)
2T2	9A09623900	IFT, AM OSC 7B (RED)
2T3	9A09624000	IFT, AM IFT 7B (WHT)
2T4	9A09624100	IFT, FM DET 7B (PNK)
2T5-6	9A09624200	IFT, MPX 8B (BLK)
2TC2	9A09624300	SVC, CYM1-2/7
2V1	9A09624400	FET, 2SK161GR
2V2	9A09624700	TR, 2SC9018H
2V3	9A09624600	TR, 2SC9014C
2V4-5	9A09589600	TR, 2SC1815GR
2V8	9A09624700	TR, 2SC9018H
2VD1-2	9A09624800	DIODE, VARACTOR V1043
2VD3-4	9A09624900	DIODE, VARACTOR V149B
2X1	9A07129000	ANT JACK

### HEADPHONE PCB ASSY

REF. NO.	PARTS NO.	DESCRIPTION
	9A09758160	HEADPHONE PCB ASSY
	9A09758200	HEADPHONE PCB
	9A09758500	HEADPHONE JACK HOLDER
7D11-12	9A09589500	DIODE, IN4148
7K1	9A06535000	HEAD PHONE JACK
7R75-76	△ 9A09758300	R, 2W 470 J

### SP SEL PCB ASSY

REF. NO.	PARTS NO.	DESCRIPTION
	9A09758660	SP SEL PCB ASSY
	9A09758700	SP SEL PCB
SWA-B	9A09758800	SP SELECTOR SW

### SP JACK PCB ASSY

REF. NO.	PARTS NO.	DESCRIPTION
	9A09759060	SP JACK PCB ASSY
	9A09759100	SP JACK PCB
	9A09759200	SP JACK

### POWER PCB ASSY

REF. NO.	PARTS NO.	DESCRIPTION
	9A09756560	POWER PCB ASSY
	9A09756600	POWER PCB
	9A06896100	FUSE CLIP
C1-3	△ 9A09587200	C, 275V 0.01UF K
FU1	△ 9A06534900	FUSE, 2A 125V SLOW BLOW
FU2	△ 9A09753200	FUSE, 6.3A 250V SLOW BLOW
FU3	△ 9A09756800	FUSE, 3.15A 250V SLOW BLOW
L1	△ 9A09756700	COIL, TOROID

# TEAC SCHEMATIC DIAGRAM AG-790 MAIN PCB (1/2)

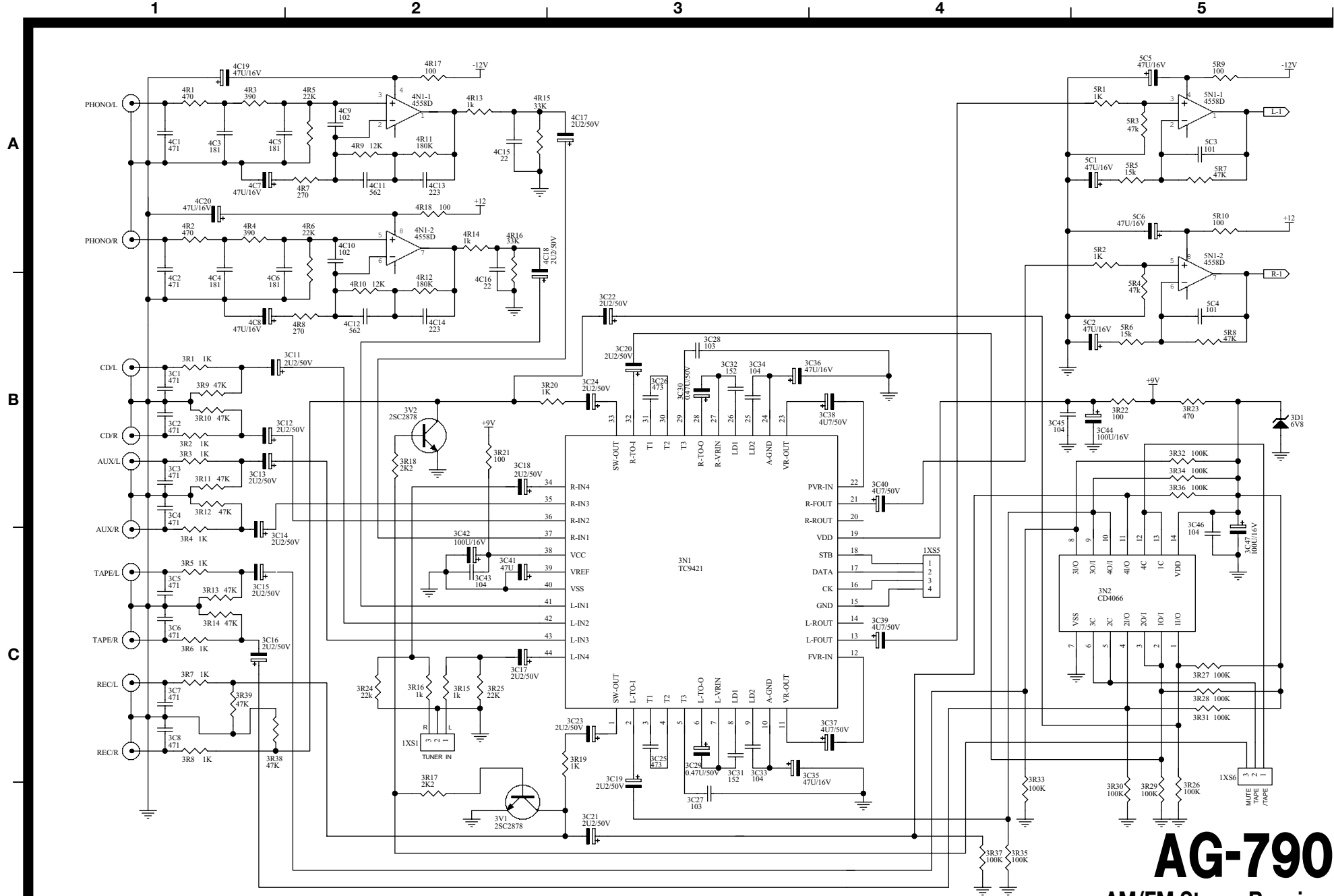

# AG-790

AM/FM Stereo Receiver

1st Issue; March 2003

# TEAC SCHEMATIC DIAGRAM AG-790 MAIN PCB (2/2), HEADPHONE PCB, SP SEL PCB, SP JACK PCB, POWER PCB

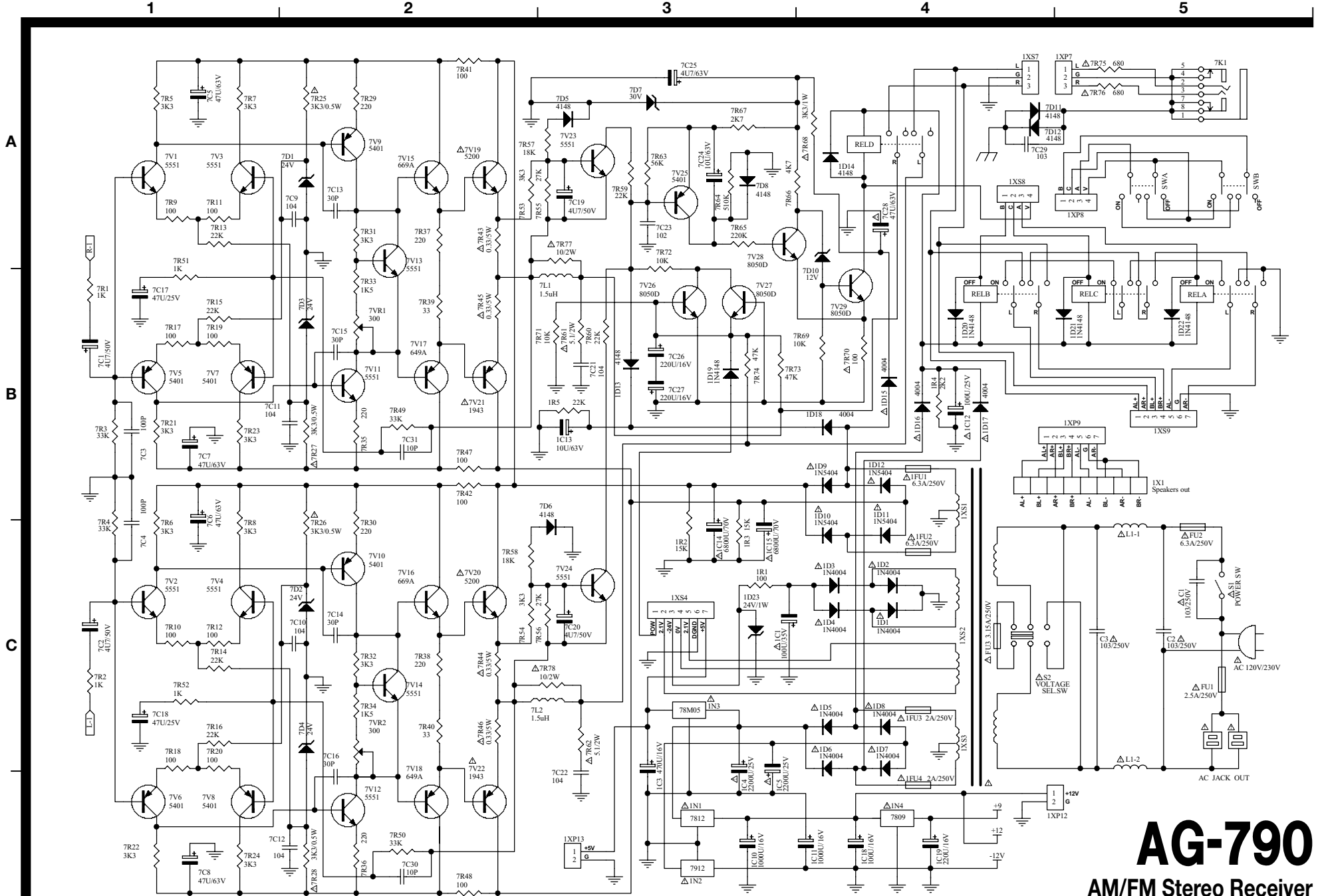

# AG-790

AM/FM Stereo Receiver

1st Issue; March 2003

# TEAC SCHEMATIC DIAGRAM AG-790 TUNER PCB

1

2

3

4

5

A

B

C

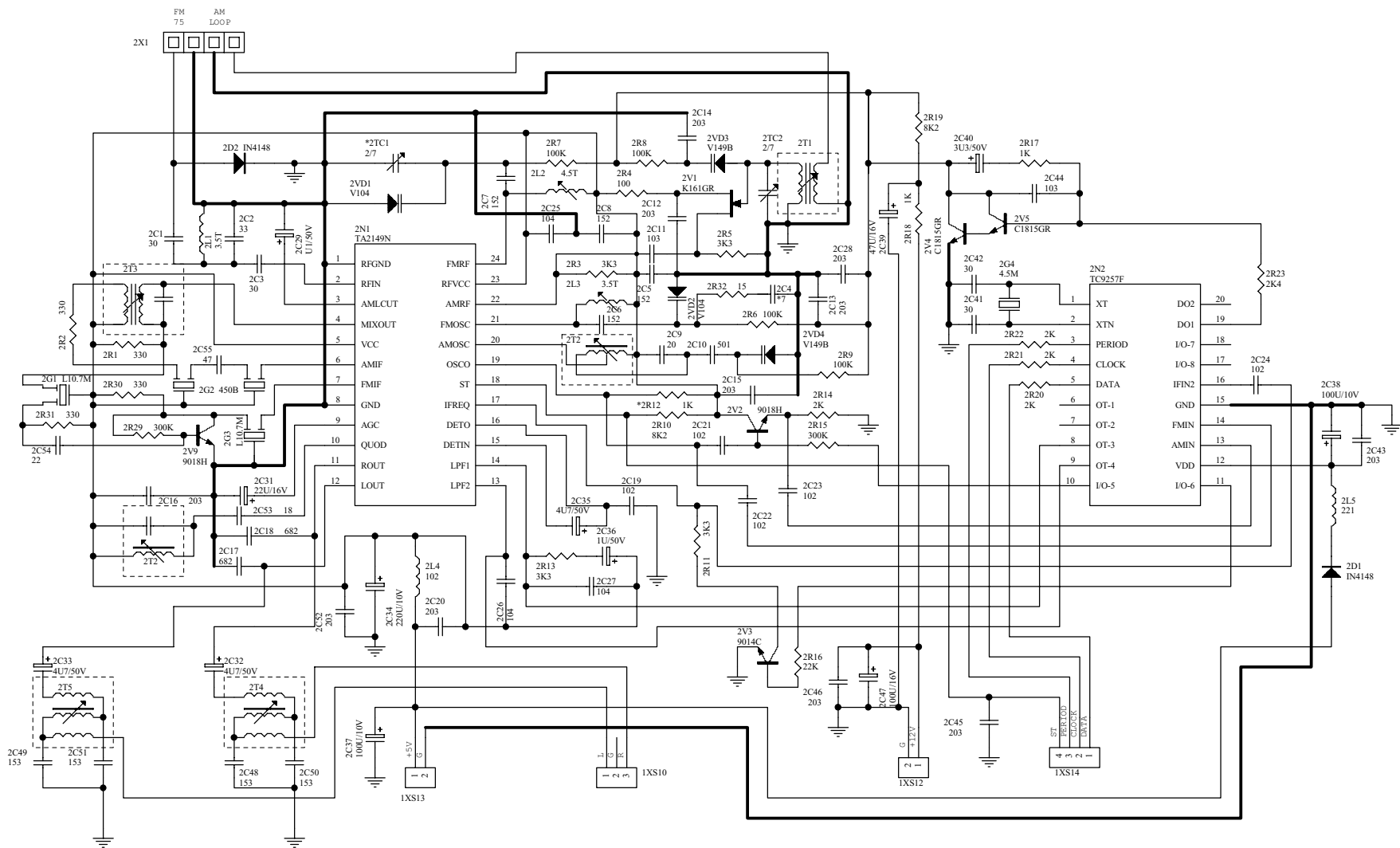

# AG-790

AM/FM Stereo Receiver

1st Issue; March 2003

# TEAC SCHEMATIC DIAGRAM AG-790 FRONT PCB

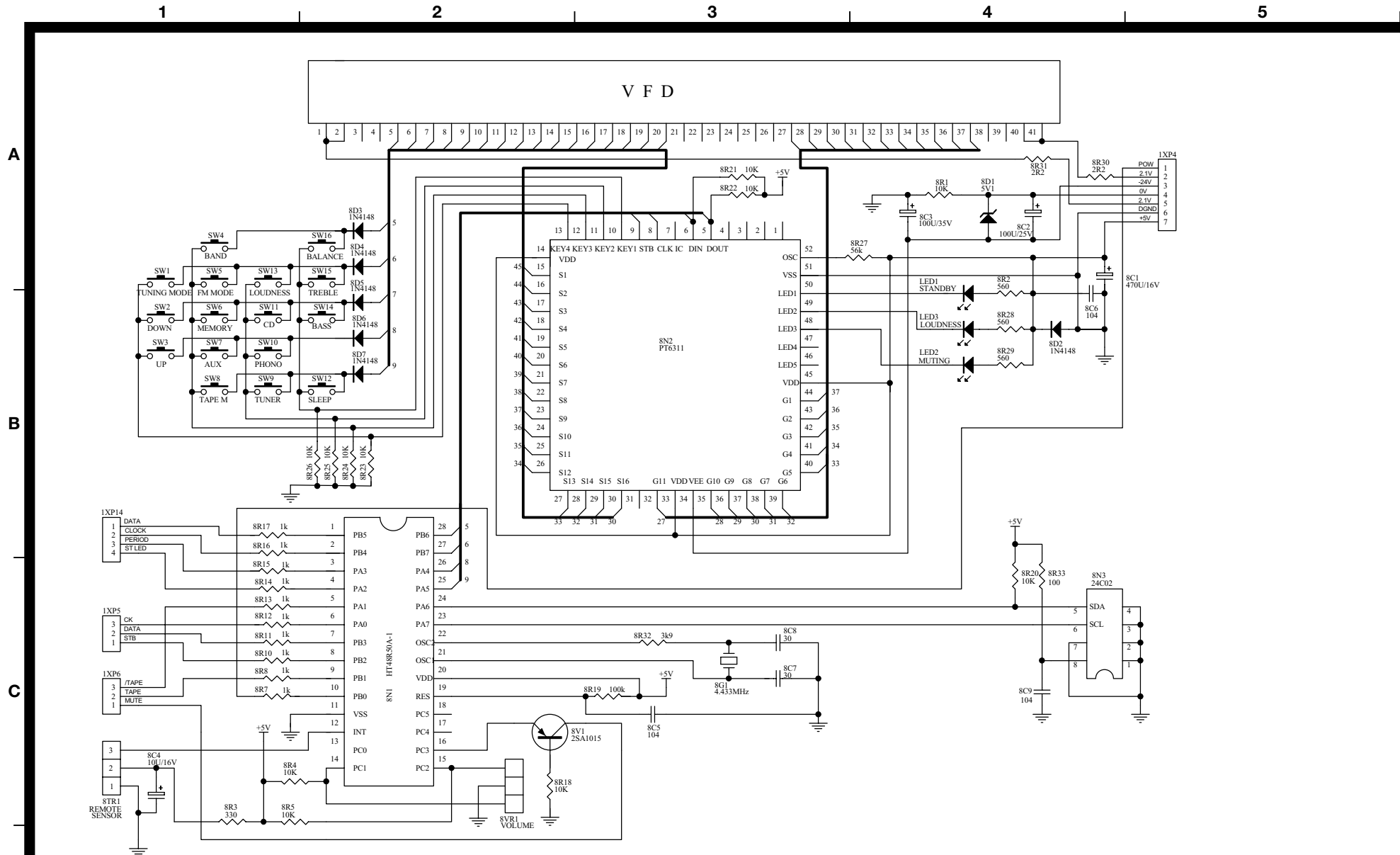

**INSTRUCTIONS FOR SERVICE PERSONNEL**  
**BEFORE RETURNING APPLIANCE TO THE CUSTOMER, MAKE LEAKAGE-CURRENT OR RESISTANCE MEASUREMENTS TO DETERMINE THAT EXPOSED PARTS ARE ACCEPTABLY INSULATED FROM THE SUPPLY CIRCUIT.**

**NOTES:**

△ Parts marked with this sign are safety critical components. They must always be replaced with identical components—refer to the appropriate parts list and ensure exact replacement.

# AG-790

AM/FM Stereo Receiver

1st Issue; March 2003