

# TEAC



## SERVICE MANUAL

# AG-D9260

AV Digital Home Theater Receiver

### NOTES

- PC boards shown are viewed from parts side.
- The parts with no reference number or no parts number in the exploded views are not supplied.
- As regards the resistors and capacitors, refer to the circuit diagrams contained in this manual.
- ⚠ Parts marked with this sign are safety critical components. They must be replaced with identical components - refer to the appropriate parts list and ensure exact replacement.
- Parts of [ ] mark can be used only with the version designated.  
[US]:U. S. A. [C]:CANADA [E]:EUROPE [UK]:U. K.

# CONTENTS

SPECIFICATIONS.....	3
SAFETY INSTRUCTIONS .....	4
MEASUREMENTS AND ADJUSTMENTS .....	5
FIP DISPLAY .....	8
DISPLAY PIN CONNECTION .....	9
IC BLOCK DIAGRAMS AND PIN FUNCTIONS .....	10
EXPLODED VIEWS AND PARTS LIST .....	22
PC BOARDS AND PARTS LIST .....	24
INCLUDED ACCESSORIES .....	29



# SAFETY INSTRUCTIONS

## PRECAUTIONS DURING SERVICING

1. Parts identified by the  $\triangle$  (\*) symbol parts are critical for safety. Replace only with parts number specified.
2. In addition to safety, other parts and assemblies are specified for conformance with such regulations as those applying to spurious radiation. These must also be replaced only with specified replacements.  
Examples :RF converters, tuner units, antenna selectswitches, RF cables, noise blocking capacitors, noise blocking filters, etc.
3. Use specified internal wiring. Note especially :
  - 1) Wires covered with PVC tubing
  - 2) Double insulated wires
  - 3) High voltage leads
4. Use specified insulating materials for hazardous live parts. Note especially:
  - 1) Insulation Tape
  - 2) PVC tubing
  - 3) Spacers(insulating barriers)
  - 4) Insulation sheets for transistors
  - 5) Plastic screws for fixing micro switches
5. When replacing AC primary side components (transformers, power cords, noise blocking capacitors, etc.), wrap ends of wires securely about the terminals before soldering.

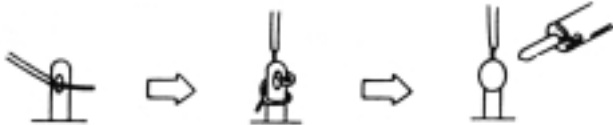

6. Make sure that wires do not contact heat producing parts (heat sinks, oxide metal film resistors, fusible resistors, etc.).
7. Check that replaced wires do not contact sharp edged or pointed parts.
8. Also check areas surrounding repaired locations.
9. Make sure that foreign objects (screws, solder droplets, etc.) do not remain inside the set.

## MAKE YOUR CONTRIBUTION TO PROTECT THE ENVIRONMENT

Used batteries with the ISO symbol for recycling as well as small accumulators (rechargeable batteries), mini-batteries (cells) and starter batteries should not be thrown into the garbage can.



Please leave them at an appropriate depot. All other household batteries can be thrown out with the household waste.

## SAFETY CHECK AFTER SERVICING

After servicing, make measurements of leakage-current or resistance in order to determine that exposed parts are acceptably insulated from the supply circuit.

The leakage-current measurement should be done between accessible metal parts (such as chassis, ground terminal, microphone jacks, signal input/output connectors, etc.) and the earth ground through a resistor of 1500 ohms paralleled with a 0.15  $\mu\text{F}$  capacitor, under the unit's normal working conditions.

The leakage-current should be less than 0.5mA rms AC. The resistance measurement should be done between accessible exposed metal parts and power cord plug prongs with the power switch (if included) "ON". The resistance should be more than 2.2M Ohms.

## PRECAUTIONS IN REPAIRING

When repairing or adjusting the unit, please note the following points.

1. Do not put excessive pressure on the mechanical part (operation part), including the pick-up block, as extremely high mechanical precision is required in these parts.
2. When the base is removed for repair adjustment, make sure that there are no metal objects in the narrow gap between the P. C. board or the mechanical parts and the base
3. The Micro-Computer and the CD signal processing ICs can be damaged by static electricity or leakage from a soldering iron during repairing. While soldering, please take the precautions against leakage as in the illustration:

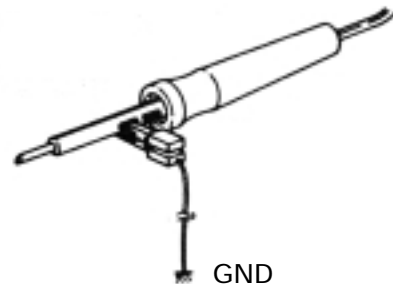

4. Do not loosen any screws in the pick-up block. When handling the pick-up block, please refer to the points to NOTE when replacing the pick-up block.
5. Keep safety for hazardous invisible Laser Radiation, DO NOT watch the Laser Beam (Objective lens) directly.
6. Models for some countries, laser warning labels are affixed on the unit and inside of the unit, as shown below. Read it carefully for your safety, when repairing or adjusting the unit.

# MEASUREMENTS AND ADJUSTMENTS

## ALIGNMENT INSTRUCTIONS

### EQUIPMENT NEEDED:

- AM Signal Generator
- FM Signal Generator
- Oscilloscope
- VTVM(AC, DC)
- Test loop antenna (AM Adjustment)
- Dummy antenna (FM Adjustment)
- Distortion analyser

### IMPORTANT

1. Check power-source voltage.
2. Set the function switch to band aligned.
3. Keep the signal input as low as possible to adjust accurately.
4. Modulation and modulation frequency.

Band \ Item	Modulation	Modulation frequency
AM	30%	400Hz
FM	100% (40 kHz Dev.) [E/UK] 100% (75 kHz Dev.) [US]	400Hz

## ADJUSTMENT POINT

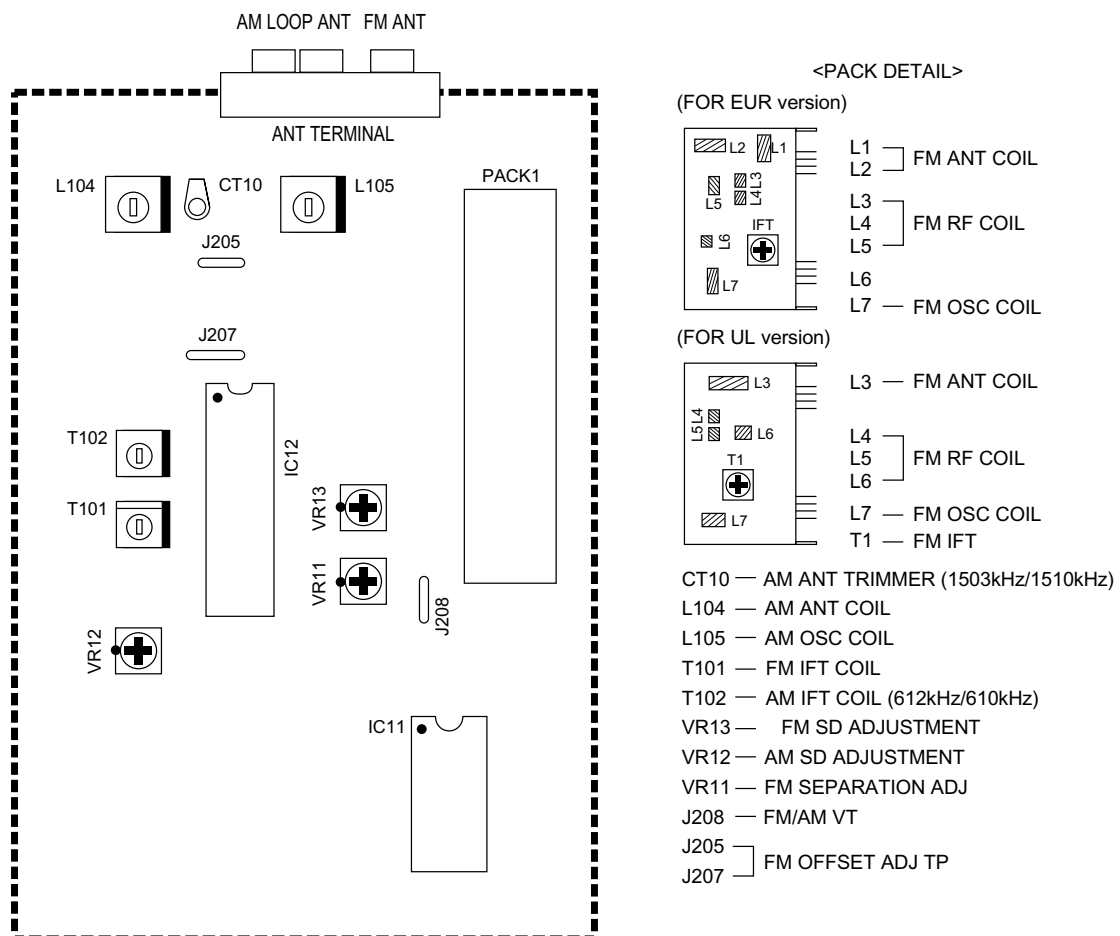

# 1. TUNING FREQUENCY RANGE ADJUSTMENTS

(FM) DC VOLTMETER ..... CONNECT TO TEST POINT J208 and GND

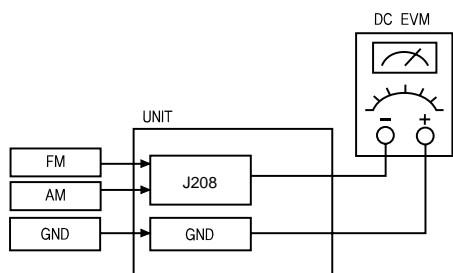

NO.	Band	Frequency	Adjust for	Adjustment
1	FM	87.50MHz	1.6V	L7
2	AM [US/C]	530 kHz [530 kHz]	1V [1V]	L105 [L105]

# 2. AM TRACKING ADJUSTMENT

Signal Generator ..... Connects to the AM ANT. Coil through the loop antenna.  
Adjust for the indication of VTVM of the wave form of scope to be maximum.

BAND	Step	Frequency	Adjust for	Adjustment
AM	1 [US/C]	610 kHz [610 kHz]	Maximum sensitivity Maximum sensitivity	T102, L104 T102, L104
	2 [US/C]	1510 kHz [1510 kHz]	Maximum sensitivity Maximum sensitivity	CT10 CT10
	3	Repeat steps 1 and 2 several times.		

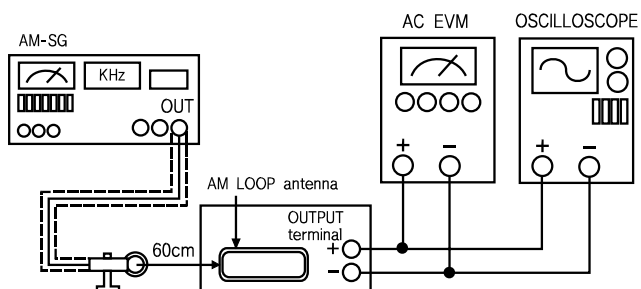

# 3. FM-RF ADJUSTMENT

Signal Generator ..... Connect to FM ANT JACK (FM IN) through the dummy.

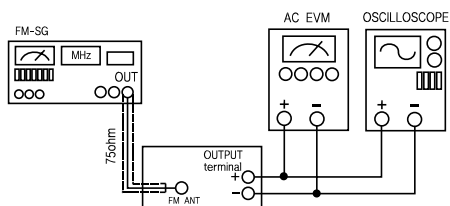

NO.	Frequency	Adjust for	Adjustment
1	90.10MHz	Maximum Sensitivity	L3, L5, L6
2	Repeat step 1 several times.		

#### 4. FM MONO DISTORTION ADJUSTMENT

DC VOLT METER .....Connect to J205 (-), J207 (+) through the choke coil (100uH).  
 Signal Generator .....Connect to FM ANT Jack (FM IN) through the dummy.  
 Distortion Meter .....Connect to the output.

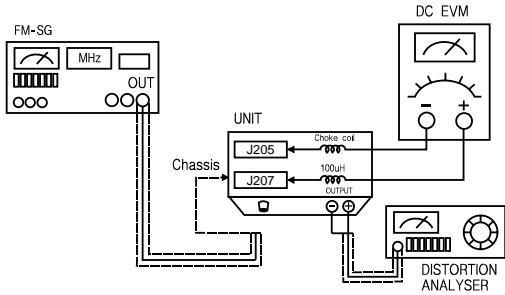

NO.	Frequency	Adjust for	Adjustment
1	100.10MHz	DC Voltmeter 0V	T101
2	100.10MHz	DC Voltmeter 0V Minimum T.H.D	T101
3	Repeat steps 1 and 2 several times.		

#### 5. FM/AM AUTO STOP LEVEL ADJUSTMENT

FM Signal Generator .....Connect to FM ANT Jack (FM IN) through the dummy.  
 AM Signal Generator .....Connect to AM ANT. Coil through the Loop antenna.

BAND	Step	Signal Generator	Adjust for	Adjustment
AM	1	990KHz 82dB	<input type="checkbox"/> TUNED Display ON	VR12
	[US/C]	[990KHz]	<input type="checkbox"/> TUNED Display OFF	VR12
FM	1	100.1MHz 32dB	<input type="checkbox"/> TUNED Display ON	VR13
	2	100.1MHz 31dB	<input type="checkbox"/> TUNED Display OFF	VR13

# FIP DISPLAY

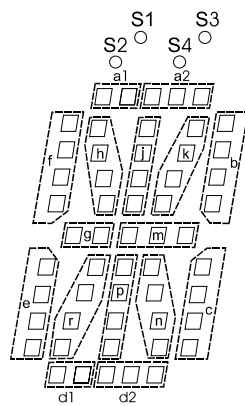
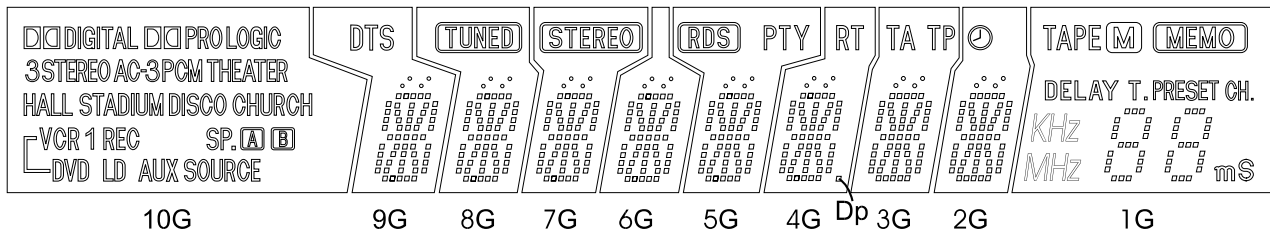

(2G~9G)

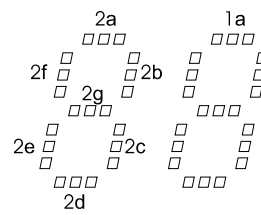

(1G)

## ANODE CONNECTION

	10G	9G	8G	7G	6G	5G	4G	3G	2G	1G
P1	SOURCE	d2	d2	d2	d2	d2	d2	d2	d2	kHz
P2	AUX	d1	d1	d1	d1	d1	d1	d1	d1	1d
P3	LD	e	e	e	e	e	e	e	e	1e
P4	DVD	r	r	r	r	r	r	r	r	1c
P5	VCR 1	p	p	p	p	p	p	p	p	1g
P6	REC	n	n	n	n	n	n	n	n	1f
P7	┌	c	c	c	c	c	c	c	c	1b
P8	SP.	f	f	f	f	f	f	f	f	1a
P9	A	g	g	g	g	g	g	g	g	M
P10	B	m	m	m	m	m	m	m	m	2d
P11	CHURCH	h	h	h	h	h	h	h	h	2e
P12	DISCO	j	j	j	j	j	j	j	j	2c
P13	STADIUM	k	k	k	k	k	k	k	k	2g
P14	HALL	b	b	b	b	b	b	b	b	2f
P15	THEATER	a2	a2	a2	a2	a2	a2	a2	a2	2b
P16	PCM	a1	a1	a1	a1	a1	a1	a1	a1	2a
P17	AC-3	S1	S1	S1	S1	S1	S1	S1	S1	DELAY.T
P18	STEREO	S2	S2	S2	S2	S2	S2	S2	S2	PRESET CH.
P19	3	S3	S3	S3	S3	S3	S3	S3	S3	MEMO
P20	□□	S4	S4	S4	S4	S4	S4	S4	S4	TAPE
P21	DIGITAL	/	/	/	/	/	RDS	Dp	TA	Ⓐ
P22	□□ PRO LOGIC	DTS	TUNED	STEREO	/	/	PTY	RT	TP	mS



# PIN CONNECTION

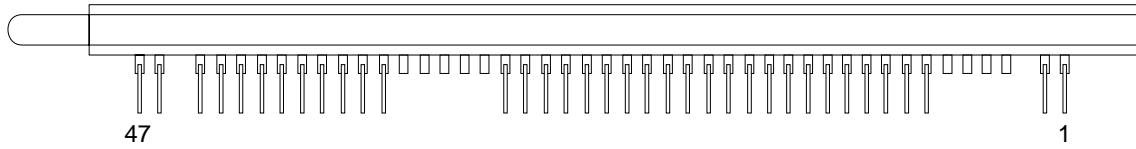

Pin No.	1	2	3	4	5	6	7	8	9	10	11	12	13	14	15
Connection	F2	F2	NP	NX	NX	NX	NX	P22	P21	P20	P19	P18	P17	P16	P15

Pin No.	16	17	18	19	20	21	22	23	24	25	26	27	28	29	30
Connection	P14	P13	P12	P11	P10	P9	P8	P7	P6	P5	P4	P3	P2	P1	NX

Pin No.	31	32	33	34	35	36	37	38	39	40	41	42	43	44	45
Connection	NX	NX	NX	NX	1G	2G	3G	4G	5G	6G	7G	8G	9G	10G	NP

Pin No.	46	47
Connection	F1	F1

# IC PIN FUNCTION (u-COM : ANAM1308AT,O.T.P :TMP87PM78F) : IC71

PIN No.	SYMBOL	I/O	DESCRIPTION
1,25	VDD	-	Power Supply Port(+5V)
2,3	Function SW1,SW2	I	Function Encoder Control Port
4	Speaker ON/OFF	O	Front Speaker Relay Drive Port("H")
5	NC	-	Not Use(No connection)
6	DSP Reset	O	Reset (Initial Clear) Port for YSS912
7	Surr. CLK	O	Surr. CLK Output Port
8	DATA OUT	O	Data Output Port for YSS912
9	Surr. DATA	O	Surr. DATA Output Port
10	CS	O	Chip Selector Port for YSS912
11	CS	O	Chip Selector Port for AK4112
12	CSBN	O	Sub DSP Chip Selector for YSS912
13,14	RDS CLK/DATA	I	RDS IC(SA6579TV1) CLK/DATA Port
15	Stereo IN	I	Stereo Display Control Port("L")
16	Tuned IN	I	Tuned Display Control Port("L")
17 - 21	KEY Matrix	I	Resistor Divide Key Control Input (17,18 Pin: NOT USE)
22,30	Vss	-	Device GND Port
23	Vass	-	Device Analog GND Port
24	Varef	-	A/D Converter Reference Voltage
26	BACKUP	I	Back Up Mode Control Input
27	TEST	-	NC(GND)
28,29	VOLUME UP/DOWN	I	Master Volume Up/Down Control Port
31	X IN	I	8MHz Crystal Connection Port
32	X OUT	O	
33	RESET (L)	I	Reset Input
34	REMOTE IN	I	Remote Control Sensor Data Input
35	BUS IN(NC)	I	System Remote Control Input(No Connection))
36	HEADPHONE IN	O	Headphone JACK INPUT("H") - Connet to GND
37	E.VOL.DATA	O	Electronic Vol. IC(M62446FP) DATA/CLK/STB Port
38	E.VOL.CLK	I	
39	E.VOL.CE	O	
40	PLL.DATA IN	I	PLL IC (LC72131) DATA Input Port
41	PLL.CE	O	PLL IC (LC72131) Chip Enable Control Port
42	DATA 3	O	Function IC Data Input Port
43	CLK 3	O	Func./PLL IC CLK Control Port
44	FUNC. STB	O	Function Strobe Control Output
45	FUNC. MUTE	O	Function Mute Control Output("H")
46	SURR. MUTE	O	Surrounc Mute Control Output("H")
47	Power ON/OFF	O	Power ON/OFF Control Port("H")
48	SURR. H	O	Surr. ON/OFF Contol Port("H")
49	PROTECT IN	I	Protect Input Port("L")
50	FIP Vkk	-	FIP (FLT) -28V Negative Power Supply For FIP Blinking
51 - 60	FIP Grid	O	FIP (FLT) Grid Control Outputs
61 - 82	FIP Segment	O	FIP (FLT) Segment Control Outputs
83 - 86	Option	I	Area/Function Option Ports
87 - 94	N.C	-	Not Use(No connection)
95	SUB. LED	O	Subwoofer LED Drive Port
96	MUTE LED	O	MUTE LED Drive Port
97 - 99	VIDED A/B/C	O	Video IC(NJM2296M/LA7952) Control Ports
100	N.C	-	Not Use(No connection)

# Micom IC Pin Assignment & Block Diagram

## ■ PIN ASSIGNMENTS

TOP VIEW :

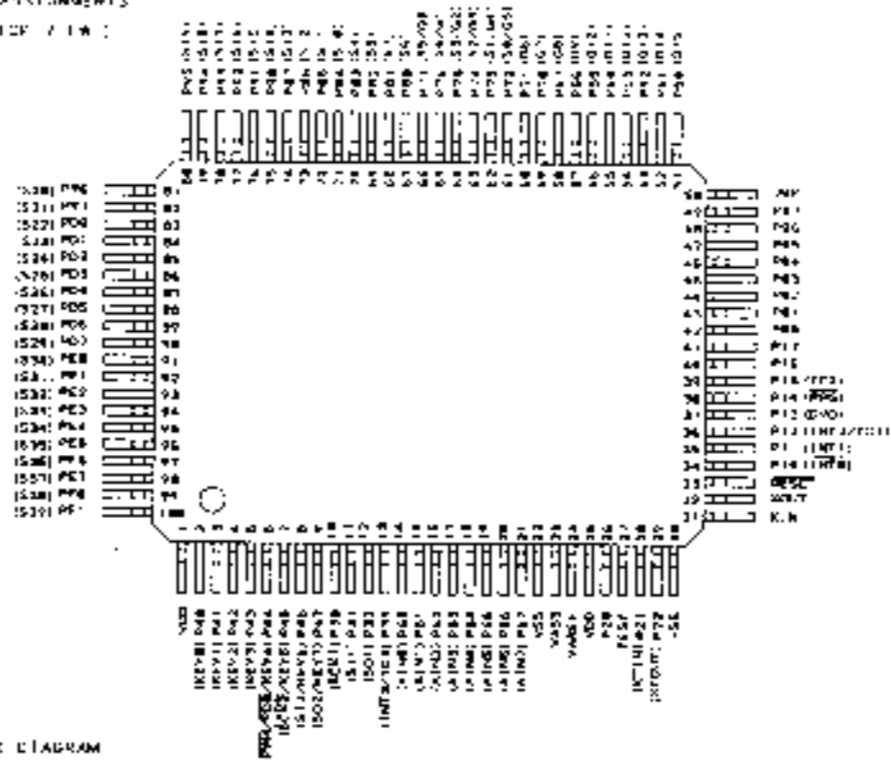

## ■ BLOCK DIAGRAM

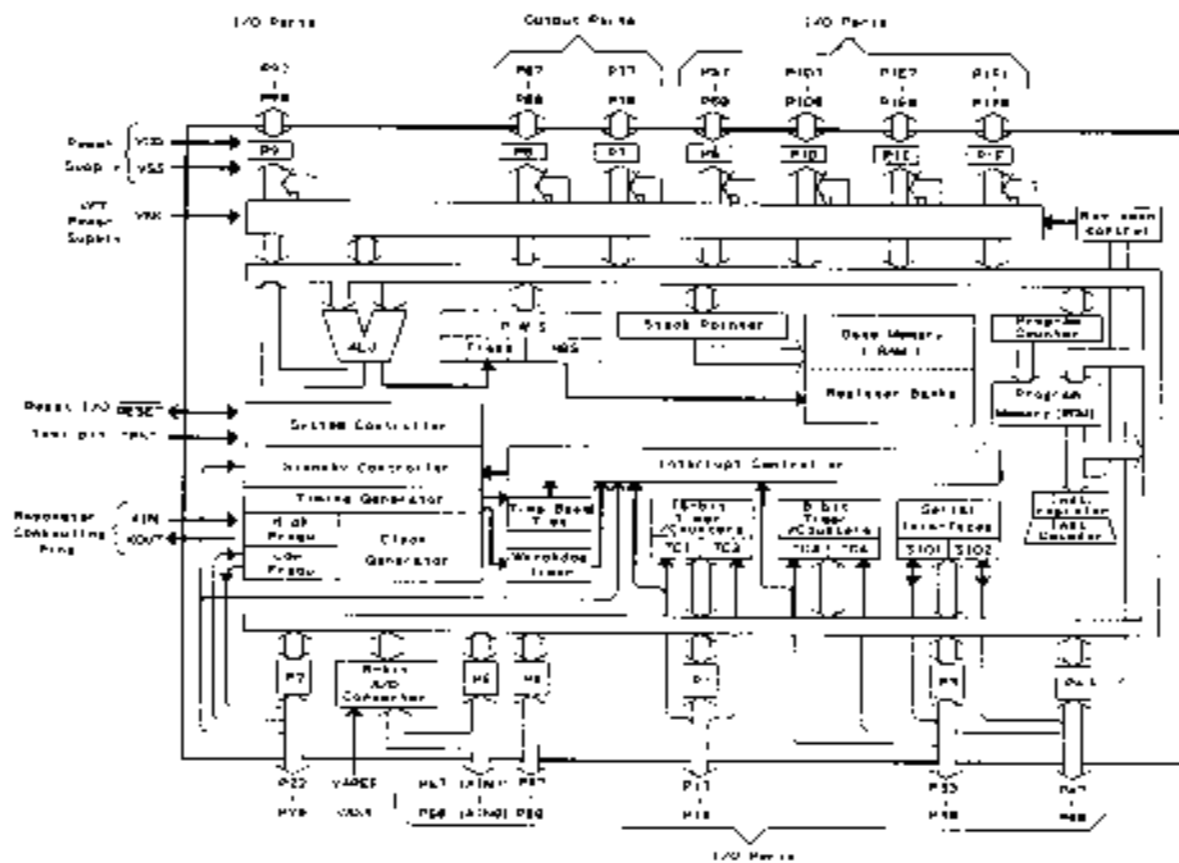

## Dolby Digital/Pro Logic DTS DECODER (YSS912C:INPUT IC43)

PIN No.	SYMBOL	I/O	DESCRIPTION
1,31,71	VDD1	-	+5V Power Supply(for I/Os)
2	RAMCEN	O	External SRAM interface /CE
3	RAMA16	O	External SRAM interface address 16
4	RAMA15	O	External SRAM interface address 15
5	SDIB0	I+	PCM input 0 to Sub DSP(not use)
6	SDIB1	I+	PCM input 1 to Sub DSP(not use)
7	SDIB2	I+	PCM input 2 to Sub DSP(not use)
8	XI	I+	Crystal oscillator connection(12.288MHz)
9	XO	O	
10, 30	VSS	-	Ground
11	AVDD	-	+3.3V power supply (for PLL circuit)
12	SDIB3	I+	PCM input 3 to Sub DSP(not use)
13	TEST	-	Test terminal(to be open in normal use)
14	TEST	-	Test terminal(to be open in normal use)
15	OVFB	O	Detection of overflow at Sub DSP (not use)
16	DTSDATA	O	Detection of DTS data (not use)
17	AC3DATA	O	Detection of AC-3 data (not use)
18	SDOB3	O	PCM output from Sub DSP
19	CPO	A	Output terminal for PLL,to be connected to ground through the external analog filter circuit
20	AVSS	-	Ground for PLL circuit)
21,41,51,81,91	VDD2	-	+3.3V power supply (for core logic)
22	SDOA2	O	PCM output from Main DSP (C,LFE)
23	SDOA1	O	PCM output from Main DSP (LS,RS)
24	SDOA0	O	PCM output from Main DSP (L,R)
25 ~ 29	RAMA 14~10	O	External SRAM interface address 14~10
32 ~ 35	OPORT 0~3	O	Output port for general purpose
36 ~ 39	OPORT 4~7	O	Output port for general purpose (not use)
40,50,60,80,90,100	VSS	-	Ground
42 ~ 44	RAAM 9~7	O	External SRAM interface address 9~7
45 ~ 47	SDOB 2~0	O	PCM output from Sub DSP
48	SDBCK1	I+	Bit clock input for SDOA,SDIB,SDOB (not use)
49	SDWCK1	I+	Word clock input for SDOA,SDIB,SDOB (not use)
52	NONPCM	O	Detection of non-PCM data (not use)
53	CRC	O	Detection of AC-3 CRC error (not use)
54	MUTE	O	Detection of auto mute (not use)
55	KARAOKE	O	Detection of AC-3 karaoke data (not use)
56	SURENC	O	Detection of AC-3 2/0 mode Dolby surround encoded input (not use)
57	/SDBCK 0	O	Inverted SDBCK0 clock output (refer to Block diagram)
58	RAMA6	O	External SRAM interface address 6
59	RAMA5	O	External SRAM interface address 5
61	RAMA4	O	External SRAM interface address 4
62	/IC	Is	Initial clear
63	TEST	-	Test terminal (to be open in normal use)
64	RAMA3	O	External SRAM interface address 3
65	/CSB	Is+	Sub DSP Chip select
66	/CS	Is	Microprocessor interface Chip select input
67	SO	Ot	Microprocessor interface serial data output
68	SI	Is	Microprocessor interface /Sub DSP Serial data input
69	SCK	Is	Microprocessor interface /Sub DSP clock input

PIN No.	SYMBOL	I/O	DESCRIPTION
70	RAMA2	O	External SRAM interface address 2
72 - 79	RAMD0-7	I+/O	External SRAM interface data (STREAM0-7 output when External SRAM is not in use)
82	SDWCK0	I	Word clock input for SDIA, SDOA, SDIB, SDOB
83	SDBCK0	I	Bit clock input for SDIA, SDOA, SDIB, SDOB
84	SDIA0	I	AC-3 Bitstream (or PCM) data input for Main DSP
85	SDIA1	I	AC-3 Bitstream (or PCM) data input for Main DSP
86	RAMA1	O	External SRAM interface address 1
87	RAMA0	O	External SRAM interface address 0
88	RAMWEN	O	External SRAM interface /WE
89	RAMOEN	O	External SRAM interface /OE
92 - 99	IPOINT7-0	I+	Input port for general purpose (not use)

NOTE) Is: Schmidt trigger input terminal  
O: Digital output terminal  
A: Analog terminal

It: Input terminal with pull-up resistor  
Ot: Tri-state digital output terminal

### YSS912C PIN CONFIGURATION

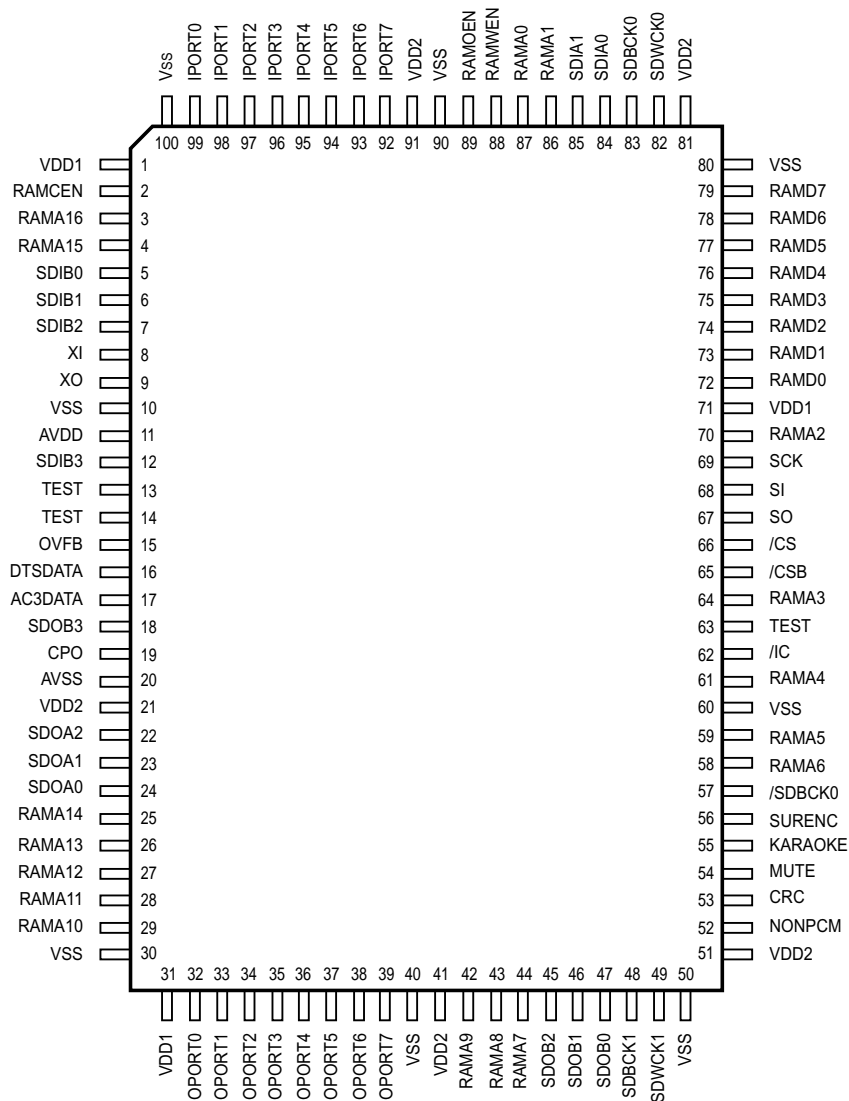

# YSS912C BLOCK DIAGRAM

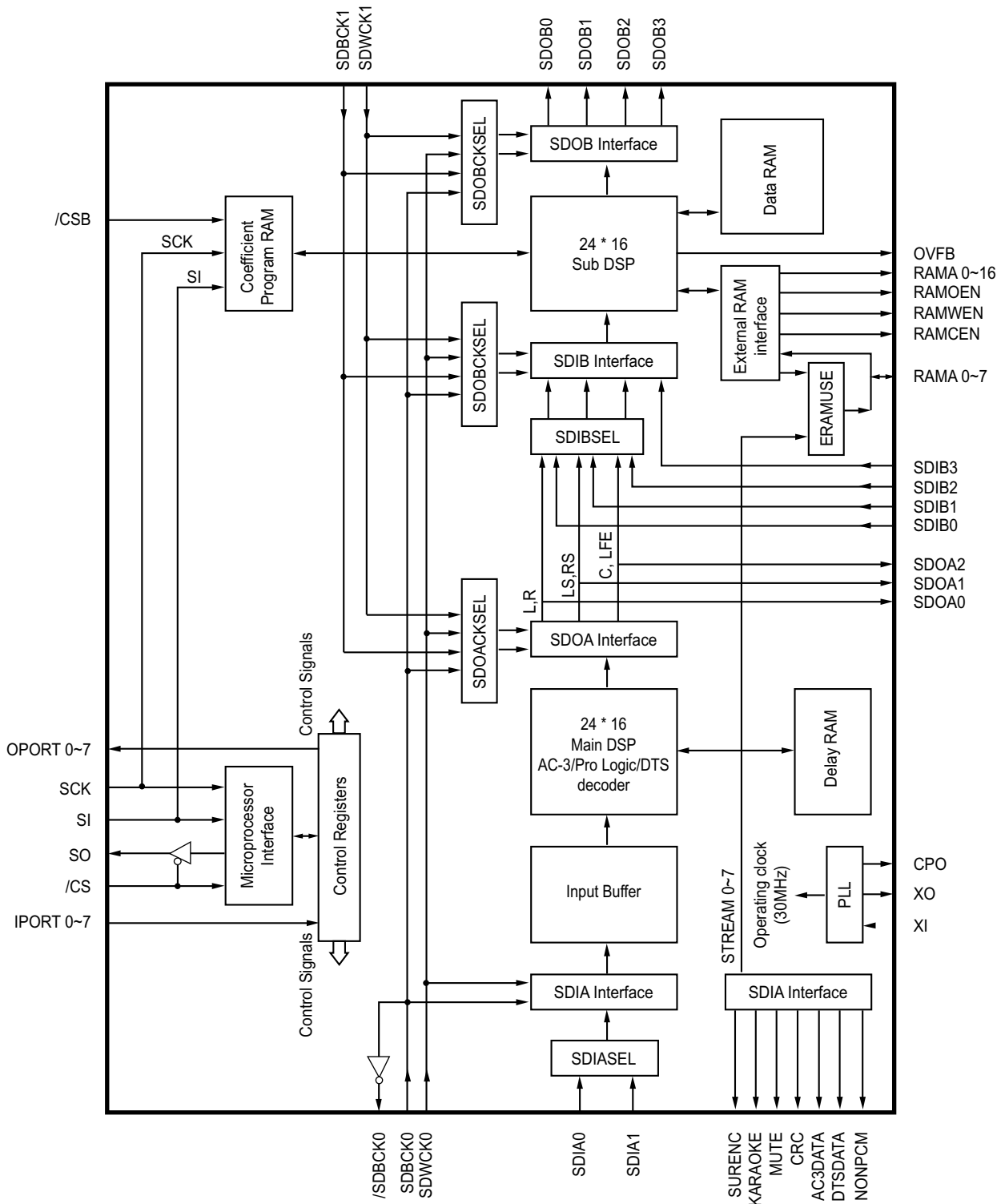

## M62446FP (ELECTRONIC VOLUME/INPUT IC31)

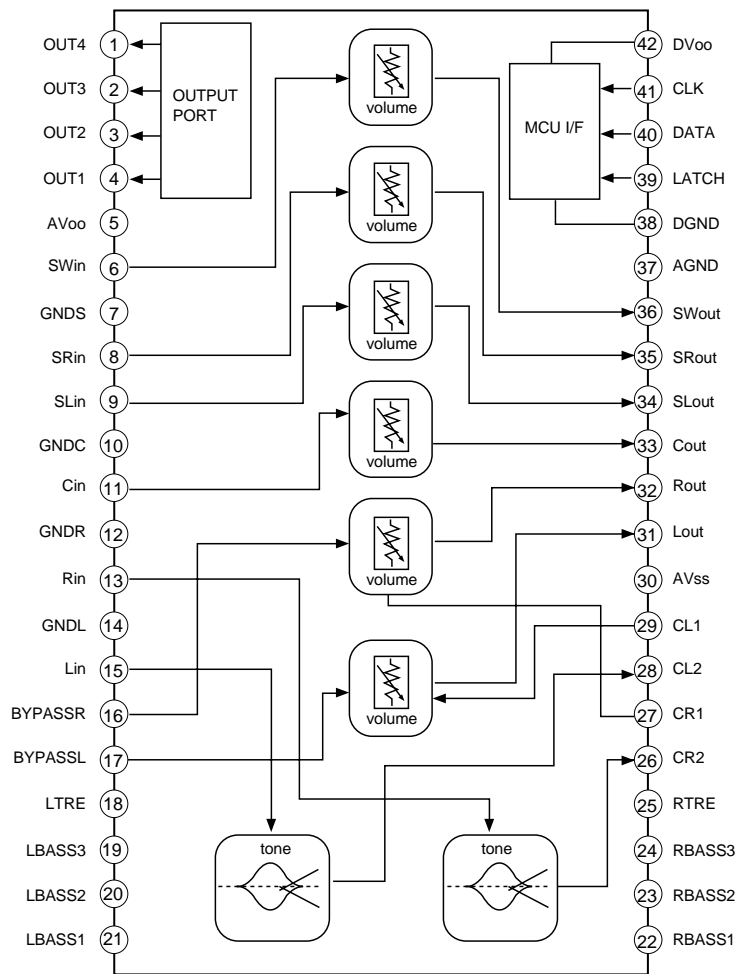

## AV4527VQ (ADC/DAC/INPUT IC42)

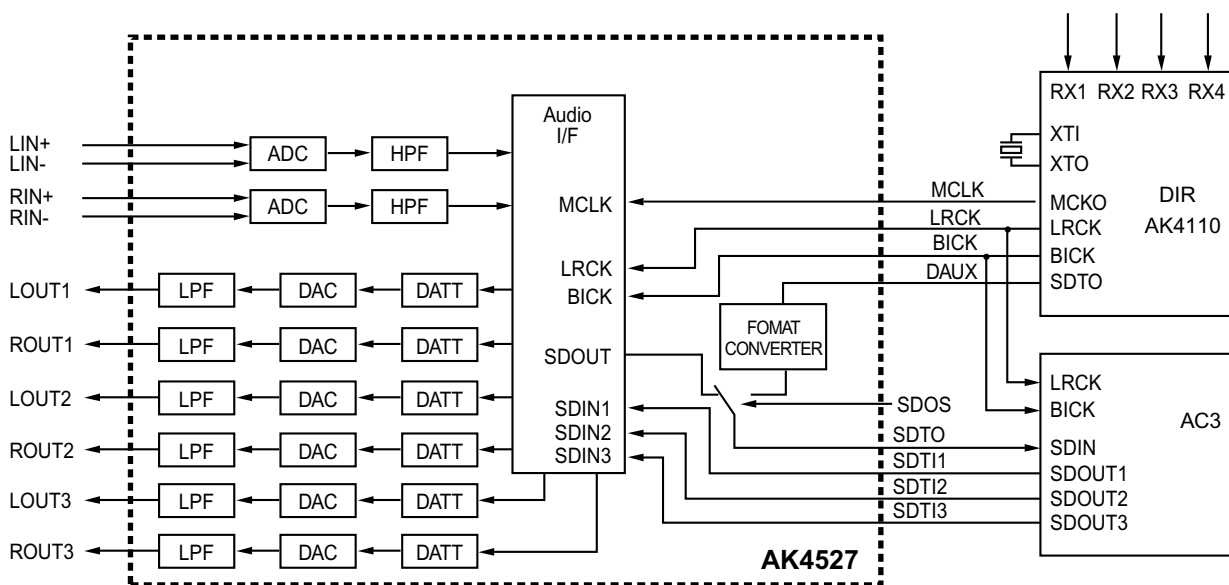

■ PIN ASSIGNMENT (74HCU04AFN : IC40)

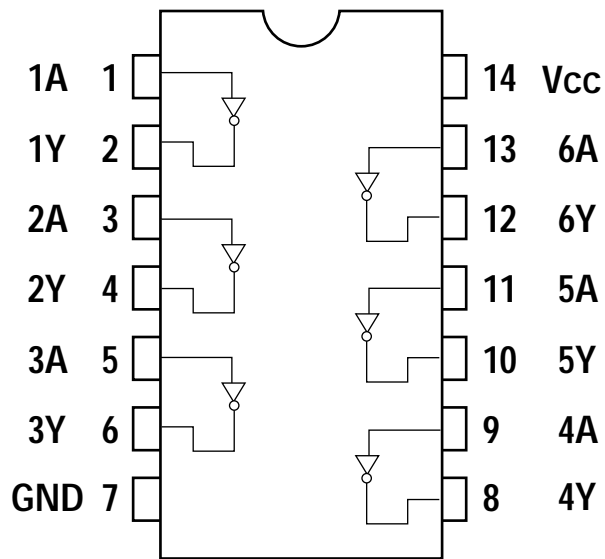

■ LOGIC SYMBOL

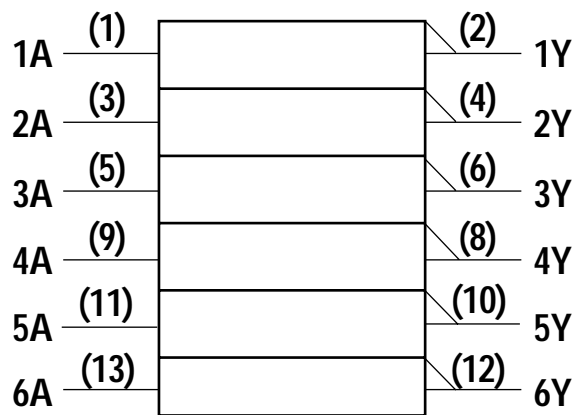

■ TRUTH TABLE

A	Y
L	H
H	L



# AK4112AVF (DIR/INPUT IC41)

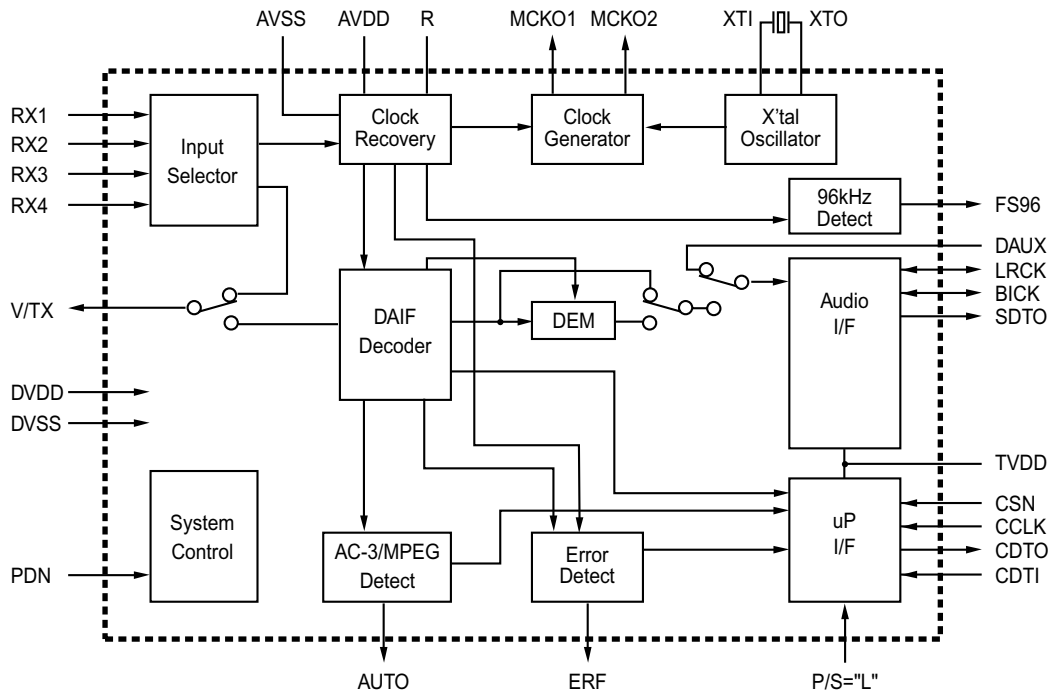

**[Serial Control Mode]**

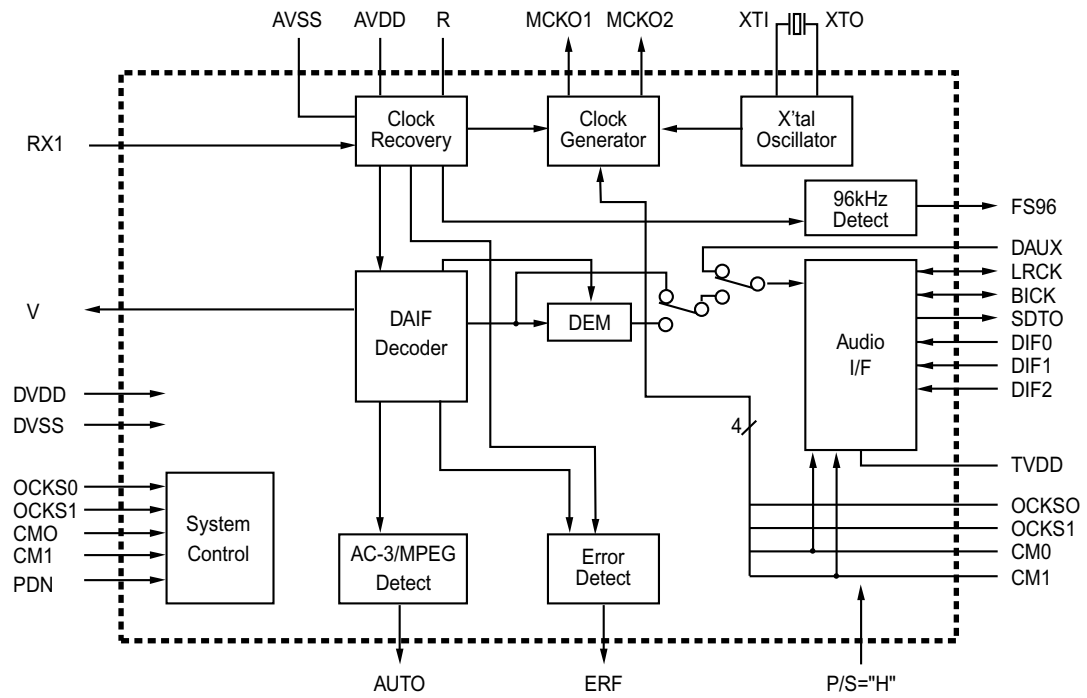

**[Parallel Control Mode]**

### LC72131 (PLL SYNTHESIZER/ TUNER IC11)

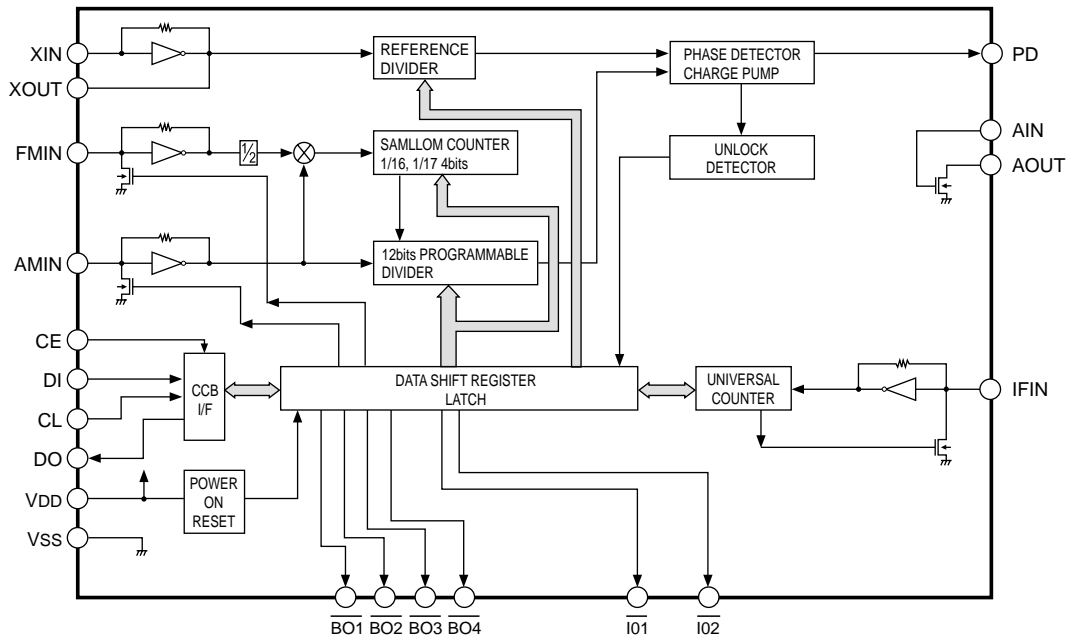

### LA1837 (MPX + IF / TUNER IC12)

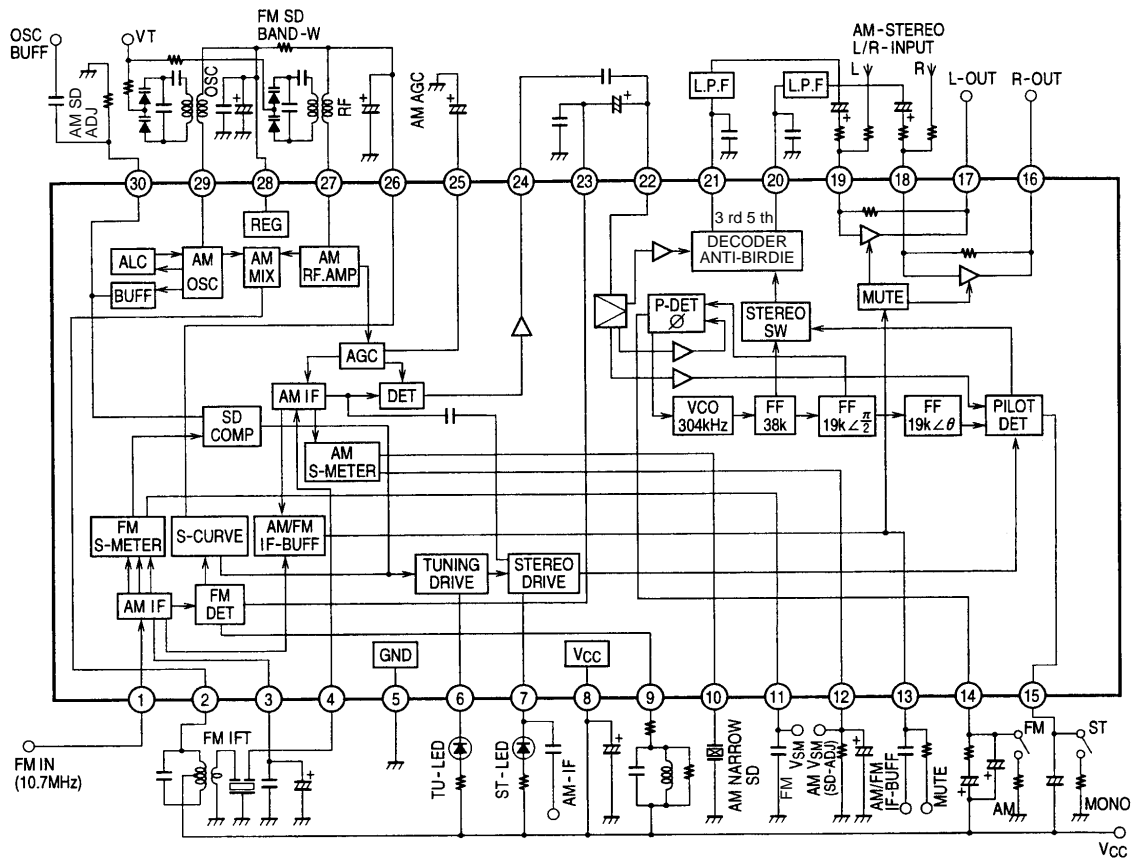

# KIC9164AF (FUNCTION/INPUT IC20)

## ■ BLOCK DIAGRAM

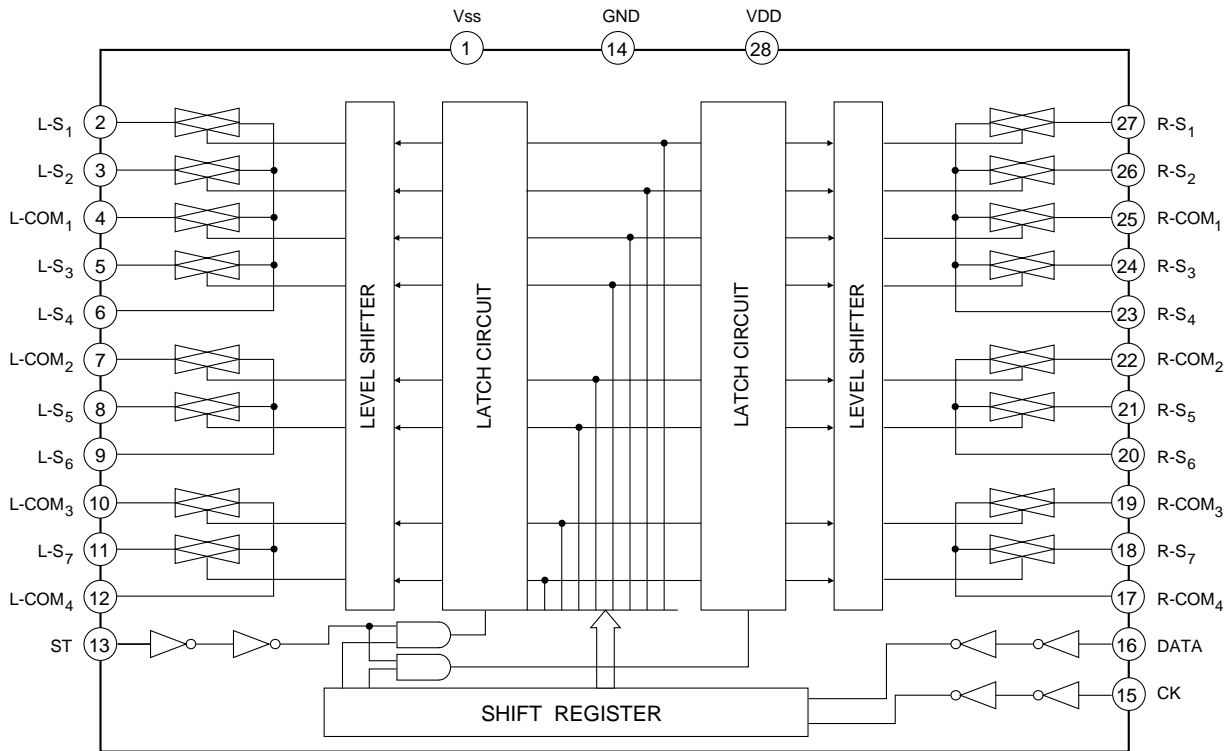

# KIC9163AF (FUNCTION/INPUT IC21)

## ■ BLOCK DIAGRAM

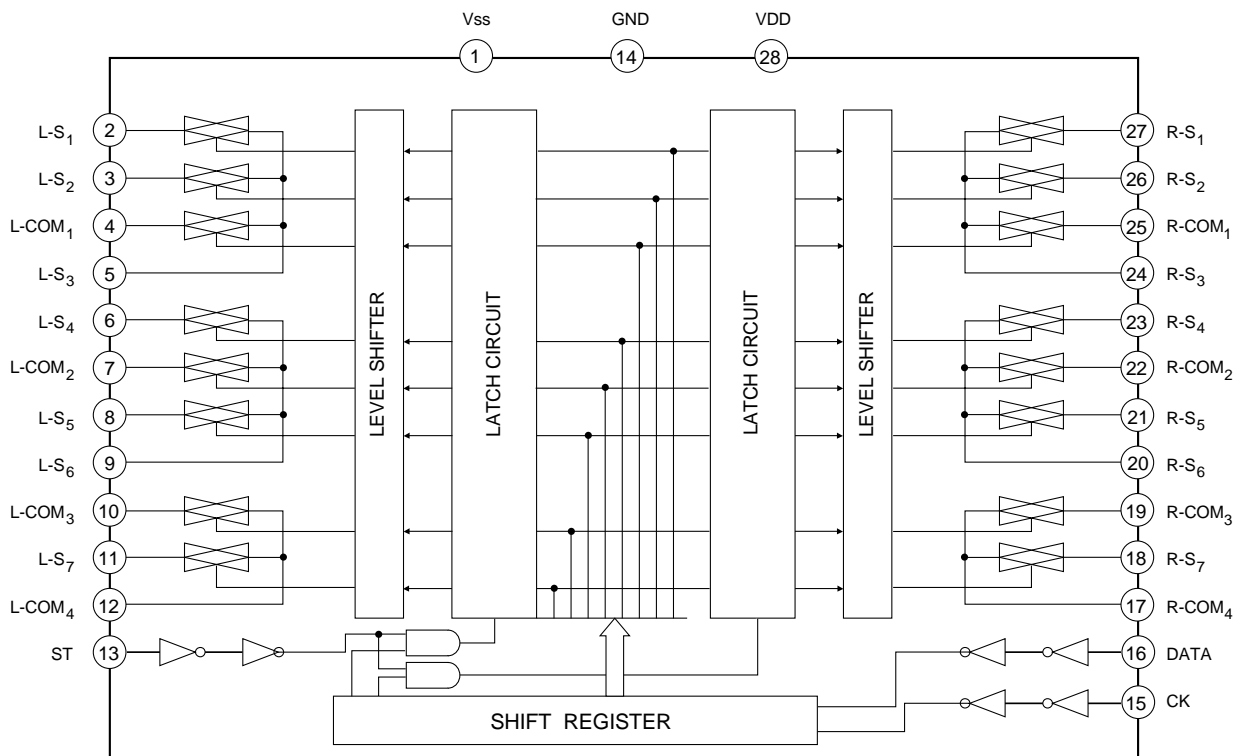

■ BLOCK DIAGAM (NJM2296M /MAIN IC96)

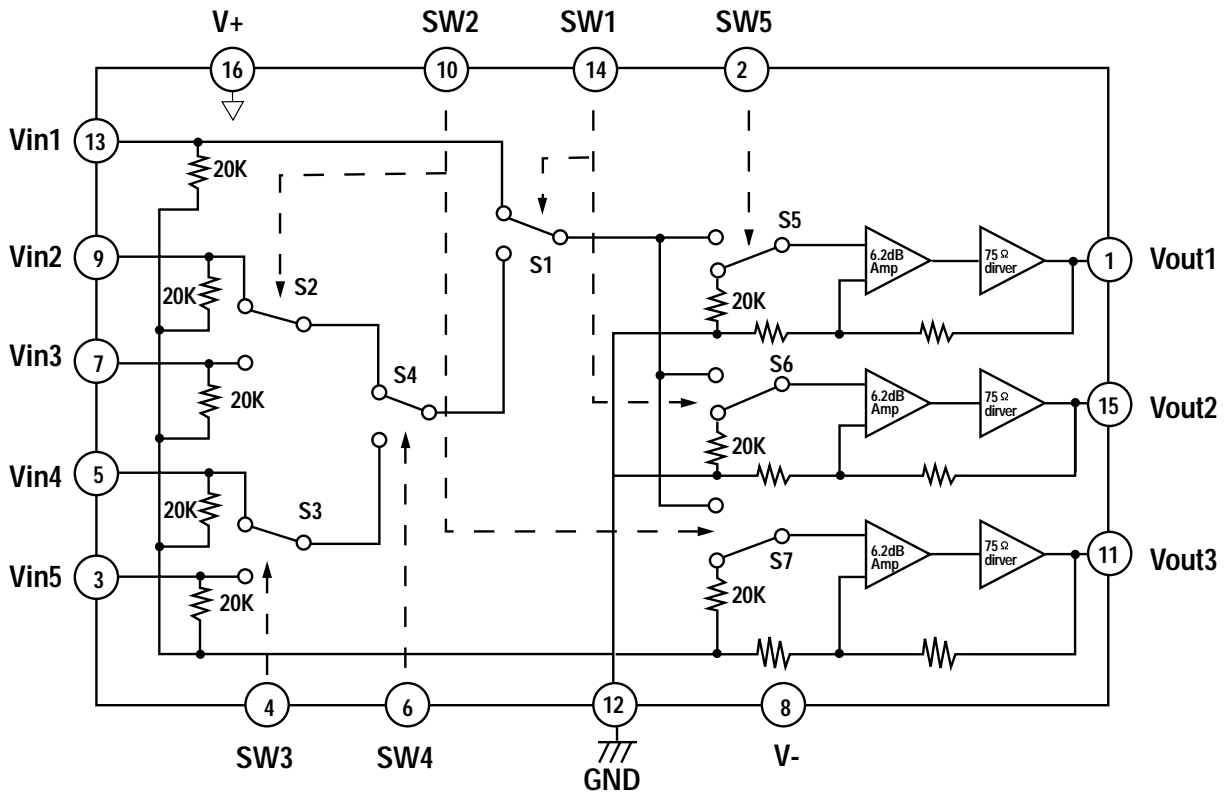







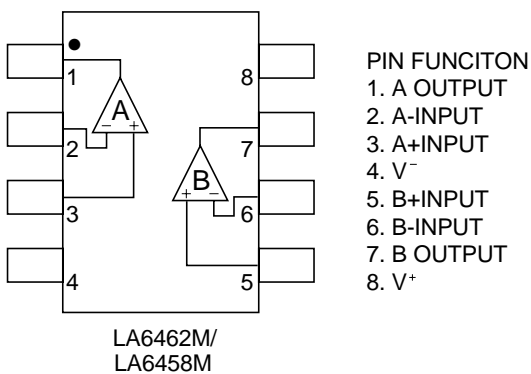

**\* Normally mute**  
**Above circuits show that the switches are set at low.**

**LA6462M/6458M**

■ PIN CONFIGURATION



## TRANSISTOR, REGULATOR IC BLOCK DIAGRAM

<p>TO-92S</p>  <p>1. Emitter 2. Collector 3. Base</p> <p><b>123</b></p> <p>KSA1175Y    KRC114M KTA1271Y    KSD811Y DTC144ES    DTA144ES DTA114YS    DTC114YS DTC143TS    DTA144TS</p>	<p>TO-92</p>  <p>1. Emitter 2. Collector 3. Base</p> <p><b>123</b></p> <p>KTD1302T    KTA1268GR KTC3200GR    KSC2785Y KTC31940</p>	<p>TO-220</p>  <p>1. INPUT 2. OUTPUT 3. GND</p> <p><b>123</b></p> <p>MC7912C</p>	<p>TO-92L</p>  <p>1. Emitter 2. Collector 3. Base</p> <p><b>123</b></p> <p>KSA916Y    KSC2316Y</p>
<p>TO-126</p>  <p>1. Emitter 2. Collector 3. Base</p> <p><b>123</b></p> <p>2SC4137V    2SC34230 2SA1360O</p>	<p>TO-220</p>  <p>1. Base 2. Collector 3. Emitter</p> <p><b>123</b></p> <p>KSA614Y    KSD288Y 2SB1186AE    2SD1763AE</p>	<p>TO-220</p>  <p>1. INPUT 2. GND 3. OUTPUT</p> <p><b>123</b></p> <p>MC7812C    MC7805C</p>	<p>TO-3P</p>  <p>1. Base 2. Collector 3. Emitter</p> <p><b>1 2 3</b></p> <p>2SC4468 2SA1695</p>

## LA7952(I.C, Video sw/ Input: IC51, IC52)

### ■ BLOCK DIAGAM/ PIN CONFIGURATION

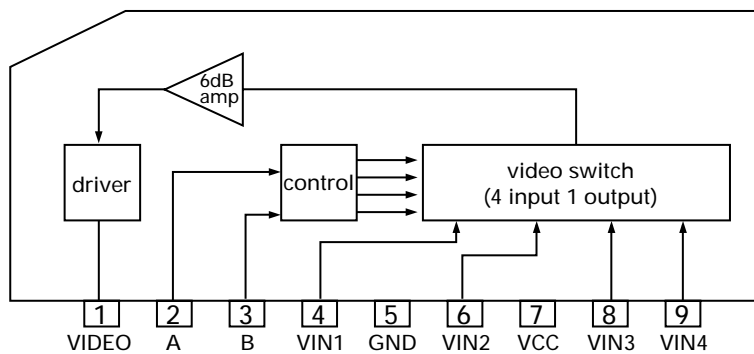

# EXPLODED VIEW (AG-D9260)

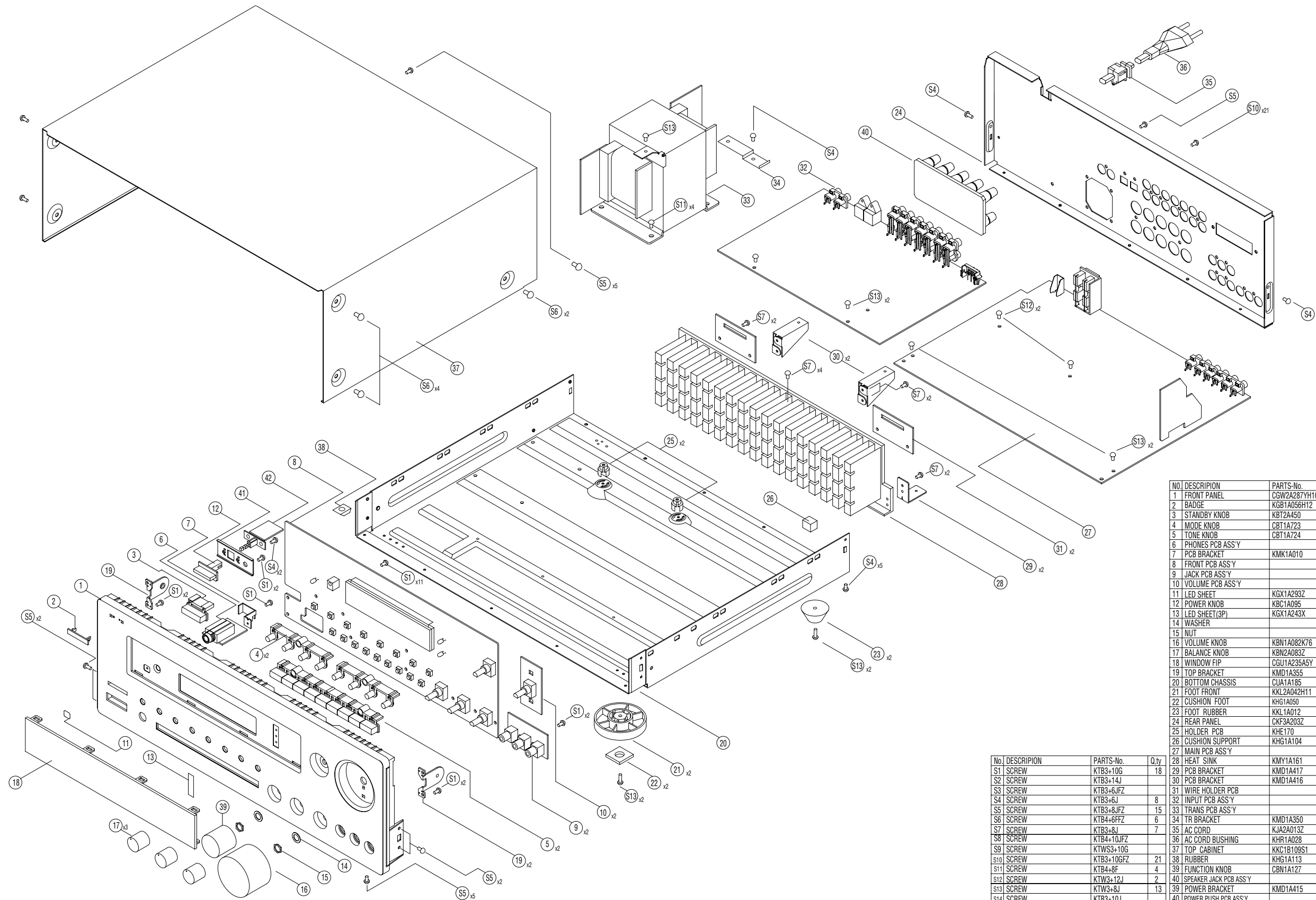

No.	DESCRIPTION	PARTS-No.	Q.ty
1	FRONT PANEL	CGW2A287YH10	1
2	BADGE	KBG1A056H12	1
3	STANDBY KNOB	KBT2A450	1
4	MODE KNOB	CBT1A723	2
5	PHONE KNOB	CBT1A724	1
6	PHONES PCB ASS'Y		1
7	PCB BRACKET	KMK1A010	1
8	FRONT PCB ASS'Y		1
9	JACK PCB ASS'Y		1
10	VOLUME PCB ASS'Y		1
11	LED SHEET	KGX1A293Z	1
12	POWER KNOB	KBC1A095	1
13	LED SHEET(3P)	KGX1A243X	1
14	WASHER		2
15	NUT		2
16	VOLUME KNOB	KBN1A082K76	2
17	BALANCE KNOB	KBN2A083Z	3
18	WINDOW FIP	CGU1A235A5Y	1
19	TOP BRACKET	KMD1A355	2
20	BOTTOM CHASSIS	CUA1A185	1
21	FOOT FRONT	KKL2A042H11	2
22	CUSHION FOOT	KHG1A050	2
23	FOOT RUBBER	KKL1A012	2
24	REAR PANEL	CKF3A203Z	1
25	HOLDER PCB	KHE170	2
26	CUSHION SUPPORT	KHG1A104	1
27	MAIN PCB ASS'Y		1
28	HEAT SINK	KMY1A161	1
S1	SCREW	KT83+10G	18
S2	SCREW	KT83+14J	1
S3	SCREW	KT83+6JFZ	1
S4	SCREW	KT83+6J	8
S5	SCREW	KT83+8JFZ	15
S6	SCREW	KT84+6FFZ	6
S7	SCREW	KT83+8J	7
S8	SCREW	KT84+10JFZ	1
S9	SCREW	KTWS3+10G	1
S10	SCREW	KT83+10GFZ	21
S11	SCREW	KT84+8F	4
S12	SCREW	KTW3+12J	2
S13	SCREW	KTW3+8J	13
S14	SCREW	KT83+10J	1
28	HEAT SINK	KMY1A161	1
29	PCB BRACKET	KMD1A417	2
30	PCB BRACKET	KMD1A416	2
31	WIRE HOLDER PCB		2
32	INPUT PCB ASS'Y		1
33	TRANS PCB ASS'Y		1
34	TR BRACKET	KMD1A350	1
35	AC CORD	KJA2A013Z	1
36	AC CORD BUSHING	KHR1A028	1
37	TOP CABINET	KKC1B109S1	1
38	RUBBER	KHG1A113	4
39	FUNCTION KNOB	CBN1A127	1
40	SPEAKER JACK PCB ASS'Y		1
39	POWER BRACKET	KMD1A415	1
40	POWER PUSH PCB ASS'Y		1

## EXPLODED VIEW

REF. NO.	PARTS NO.	DESCRIPTION
1	9A08904800 9A08904810 9A08959600	PANEL, FRONT [US, C, UK (B)] PANEL, FRONT [E] PANEL, FRONT [UK (N)]
2	9A07047400 9A08887100	BADGE [Except UK (N)] BADGE [UK (N)]
3	9A06777500 9A08959500	KNOB, POWER [Except UK (N)] KNOB, STANDBY [UK (N)]
4	9A08904600 9A08959300	KNOB, MODE [Except UK (N)] KNOB, MODE [UK (N)]
5	9A08904700 9A08959400	KNOB, TONE [Except UK (N)] KNOB, TONE [UK (N)]
6	-----	PHONES PCB ASSY
7	9A08886900	BRACKET, PCB
8	9A08905000 9A08905010	FRONT PCB ASSY [US, C] FRONT PCB ASSY [E, UK]
9	-----	JACK PCB ASSY
10	-----	VOLUME PCB ASSY
11	9A08887200	SHEET, LED
12	9A06783600 9A08959100	KNOB, POWER [E, UK (B)] KNOB, POWER [UK (N)]
13	9A08045300	SHEET, LED (3P)
16	9A07045100 9A08958400	KNOB, FUNCTION [Except UK (N)] KNOB, VOLUME [UK (N)]
17	9A08937100 9A08958600	KNOB, BASS [Except UK (N)] KNOB, ROTARY [UK (N)]
18	9A08904300	WINDOW, FIP
19	9A08886800	BRACKET, TOP
20	9A08888100	CHASSIS, BOTTOM
21	9A08887600	FOOT, FRONT
22	9A06754800	RUBBER, CUSHION
23	9A06755300	FOOT, RUBBER (BLACK)
24	9A08938900 9A08938910 9A08938920	PANEL, REAR [US, C] PANEL, REAR [E] PANEL, REAR [UK]
25	9A01375500	PCB HOLDER
26	9A06327100	SUPPORT, CUSHION
27	9A08939400 9A08939410 9A08939420	MAIN PCB ASSY [US, C] MAIN PCB ASSY [E] MAIN PCB ASSY [UK]
28	9A08952200	HEAT SINK
29	9A08952300	BRACKET, PCB
30	9A08745400	BRACKET, PCB (H/T)
31	-----	WIRE HOLDER PCB
32	9A08939500 9A08939510	INPUT PCB ASSY [US, C] INPUT PCB ASSY [E, UK]
33	△ 9A08904000 △ 9A08939300 △ 9A08959700	TRANSFORMER, POWER [E, UK (B)] TRANSFORMER, POWER [US, C] TRANSFORMER, POWER [UK (N)]
34	9A08887800	BRACKET, TR
35	△ 9A07872600 △ 9A07916800 △ 9A08956900	POWER CORD [US, C] POWER CORD [UK] POWER CORD [E]
36	△ 9A06754900	BUSHING, AC CORD
37	9A08810200 9A08885800	CABINET, TOP [Except UK (N)] CABINET, TOP [UK (N)]

REF. NO.	PARTS NO.	DESCRIPTION
38	9A08885700	RUBBER
39	9A08904200 9A08958500	KNOB, FUNCTION [Except UK (N)] KNOB, FUNCTION [UK (N)]
40	-----	SPEAKER JACK PCB ASSY
41	9A08957700	BRACKET, POWER [UK]
42	-----	POWER PUSH PCB ASSY
	9A08038100	RING, FERRITE
CN10	9A08887300	CABLE, CARD
CN11	9A08887400	CABLE, CARD
F901	△ 9A06756100	FUSE, 2.5A 250V [US, C, E]
F902	△ 9A06537400	FUSE, 4A 250V [E, UK]
F902	△ 9A07371000	FUSE, 6.3A 250V [US, C]
F903, F904	△ 9A07044800	FUSE, 8A 250V

### Note

UK(B): Black Version, UK(N): Gold Version

CUP11345Y-3

CUP11345

CUP11345Y-4

S-VIDEO CUP11345Y-2

IC ICTDJ1DJ2RP

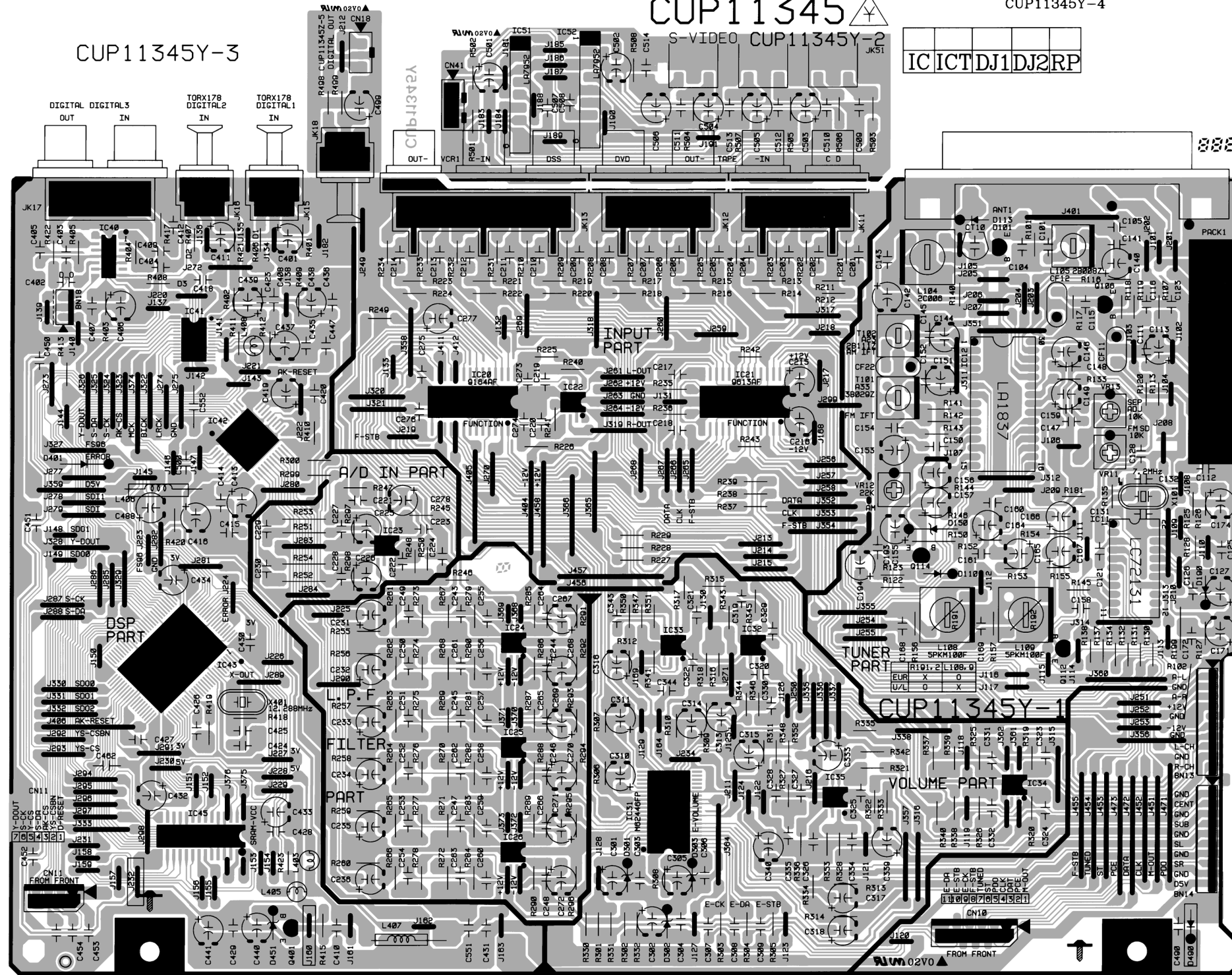



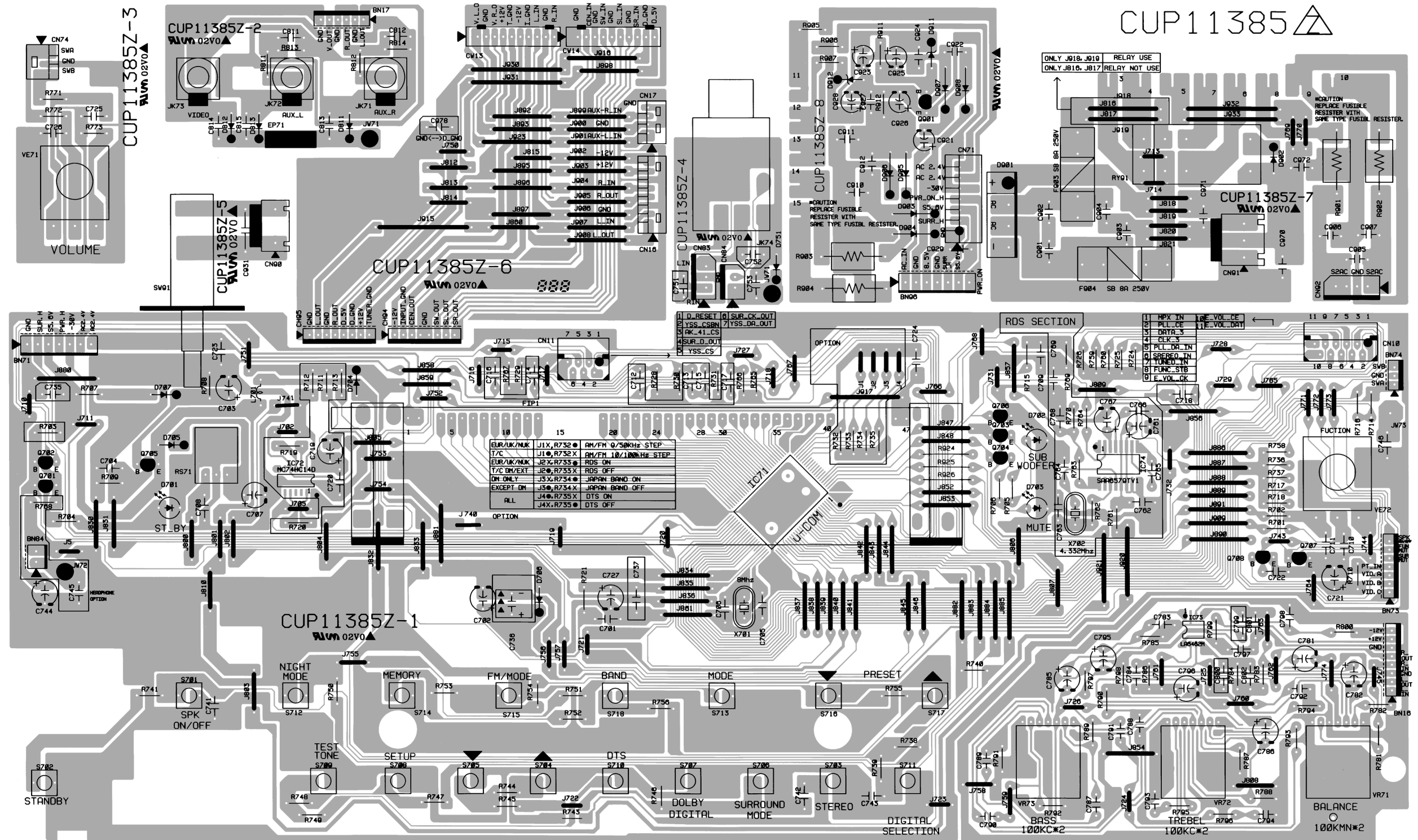



## INPUT PCB ASSY

REF. NO.	PARTS NO.	DESCRIPTION
	9A08939500	INPUT PCB ASSY [US, C]
	9A08939510	INPUT PCB ASSY [E, UK]
	9A08953300	INPUT PCB
	9A08215300	PACK, FRONT END [US, C]
	9A08957300	PACK, TUNER [E, UK]
ANT1	9A07371900	TERMINAL, ANT [US, C]
ANT1	9A08957400	TERMINAL, ANT [E, UK]
BN13, BN14	9A08036700	WAFER
CF11, CF12	9A06544600	FILTER, CERAMIC E107MSHAT
CF22	9A07006300	FILTER, CERAMIC PBF450JR3
CN10	9A08947300	WAFER, CARDCABLE
CN11	9A08947400	WAFER, CARDCABLE
CN41	9A05356300	WAFER, 04GA192M
CT10	9A01405900	C, VARIABLE 20PF
D101	9A08163000	DIODE, VARICAP SVC342-L-AA
D110, D113	9A08878200	DIODE, 1SS133T-77
D150	9A07892400	DIODE, ZENER 9.1V 1/2W
D190	9A08954100	DIODE, ZENER MTZJ5.1BT
D301, D302	9A08951100	DIODE, ZENER MTZJ6.8BT
D303	9A08954100	DIODE, ZENER MTZJ5.1BT
D401	9A08954200	DIODE, 1N4148T
D451	9A08954300	DIODE, ZENER MTZJ4.7BT
IC11	9A08947500	IC, PLL
IC12	9A08033000	IC, LA1837
IC20	9A08947600	IC, KIC9164AF
IC21	9A08947700	IC, KIC9163AF
IC22	9A08889900	IC, LA6462M
IC23-IC26	9A08947800	IC, LA6458M
IC31	9A08947900	IC, M62446FP
IC32, IC34	9A08889900	IC, LA6462M
IC33, IC35	9A08947800	IC, LA6458M
IC40	9A08948000	IC, TC74HCU04AFN
IC41	9A08948100	IC, AK4112A-VF-E2
IC42	9A08903900	IC, AK4527VQ
IC43	9A08033700	IC, YSS912C-F
IC45	9A08032900	IC, IS61C256AH-15J
IC51, IC52	9A08948200	IC, LA7952
JK11, JK12	9A07425400	JACK, IN/OUT
JK13	9A07425500	TERMINAL, IN/OUT
JK15, JK16	9A08948300	MODULE, OPTICAL TORX178A
JK17	9A08948400	JACK, BOARD(2P)
JK51	9A08948500	JACK, S-VIDEO(3P/H)
L104	9A08948600	COIL, MW ANT
L105	9A07873300	COIL, AM OSC
L108, L109	9A08957500	COIL, MPX [E, UK]
L403	9A08037600	COIL, 10UH J
L405, L408	9A08037600	COIL, 10UH J
L406, L407	9A07050600	BEAD, CORE
Q106	9A08954400	TR, KTC31940T
Q112	9A08884100	TR, KRA107M
Q114	9A08878300	TR, KRC107M
Q401	9A07888000	TR, KSC2316YT
R102	△ 9A08948700	R, CARBON 4.7 OHM 1/2W J
T101	9A08125500	IFT, FM
T102	9A08125400	IFT, AM
VR11, VR13	9A08040600	R, SEMI-FIXED 10K OHM
VR12	9A08040700	R, SEMI-FIXED 22K OHM
X101	9A08883700	CRYSTAL
X401	9A08949000	CRYSTAL

## FRONT PCB ASSY

REF. NO.	PARTS NO.	DESCRIPTION
	9A08905000	FRONT PCB ASSY [US, C]
	9A08905010	FRONT PCB ASSY [E, UK]
	9A08905200	FRONT PCB
BK71, BK72	9A08888700	BRACKET, FLT
CH94, CH95	9A08889400	CONNECTOR, HOUSING
CN10	9A08889500	WAFER, CARDCABLE
CN11	9A08889600	WAFER, CARDCABLE
CN16	9A08036300	WAFER
CN17	9A07335100	WAFER, MOLEX 53015
CN71	9A07049700	WAFER
CN74	9A07049500	WAFER, MOLEX 53015-0310
CN83	9A05329100	WAFER, MOLEX 5267-03A
CN90	9A06785000	WAFER [E, UK]
CN91	9A06759300	WAFER
CN92	9A05329300	WAFER, MOLEX 5267-04A
CW13, CW14	9A08036600	WAFER, MOLEX 35336-1010
C931	△ 9A08882700	C, CERAMIC (KH TYPE) [E, UK]
D701-D703	9A08147300	LED, SLR342VCTB7 (RED)
D704-D707	9A08878200	DIODE, 1SS133T-77
D901	△ 9A08889700	DIODE, BRIDGE
D903-D908	△ 9A05194700	DIODE, 1N4003ST
D911	9A08905700	DIODE, ZENER MTZJ30BT
D912	9A07887100	DIODE, ZENER 6.2V
EP71	9A05961500	PLATE, EARTH
FIP1	9A08034600	FIP, SVA-10MS11
F903, F904	9A05328200	HOLDER, FUSE
IC71	9A08889800	IC, TMP87PM78F
IC73	9A08889900	IC, LA6462M
IC74	9A08033400	IC, SAA6579T/V1 [E, UK]
JK71-JK73	9A08890000	JACK, VCR
JK73	9A07491600	JACK
L701	9A07886600	COIL, 10UH
Q701	9A08905800	TR, KRA104MT
Q702	9A08905900	TR, KRC114MT
Q703, Q704	9A08878300	TR, KRC107M
Q705	9A07887900	TR, KSB811YT
Q706-Q708	9A08878300	TR, KRC107M
Q901	9A08906000	TR, KTA1271YT
RS71	9A08563600	SENSOR, REMOCON
R901-R904	△ 9A05897200	R, FUSE 0.47 OHM 1W
SW91	△ 9A06784700	SW, PUSH [E, UK]
S701-S718	9A07878500	SW, TACT SKHV10910G
VE71	9A08890200	VR, ENCODER 2A004Z
VE72	9A08890300	VR, ENCODER 2A006Z
VR71	9A08890400	R, VARIABLE (BALANCE)
VR72, VR73	9A08890500	R, VARIABLE (TONE)
X701	9A08879000	CRYSTAL
X702	9A07501700	CRYSTAL [E, UK]

**MAIN PCB ASSY**

REF. NO.	PARTS NO.	DESCRIPTION
	9A08939400	MAIN PCB ASSY [US, C]
	9A08939410	MAIN PCB ASSY [E]
	9A08939420	MAIN PCB ASSY [UK]
	9A08950900	MAIN PCB
	9A08952200	HEAT SINK
	9A08745400	BRACKET, PCB (H/T)
	9A08952300	BRACKET, PCB
CN17	9A06250600	WAFER, 02GA19ZM
CN73	9A05356500	WAFER, MOLEX 53014-0710
CN91	9A06674400	WAFER
CN92	9A06785000	WAFER
CN94, CN95	9A08891200	WAFER, 08GA98ZM
CN96	9A05330000	WAFER, MOLEX 5267-07A
CN97	9A07049600	WAFER
CN98	9A05973000	WAFER, 8P
CN99	9A05967700	WAFER
C903	△ 9A08032200	C, LINE ACROSS 0.1UF 250V
C904	△ 9A08882700	C, CERAMIC DE7150-610F472M
C906	△ 9A08944600	C, ELECT 1000UF 25V
C915, C916	△ 9A08944700	C, ELECT 8200UF 63V
C917	△ 9A08944800	C, ELECT 3300UF 25V
C918	△ 9A07897200	C, ELECT 2200UF 25V
C961	△ 9A08944900	C, ELECT 3300UF 16V
D501, D502	9A08878200	DIODE, 1SS133T-77
D507, D508	9A08878200	DIODE, 1SS133T-77
D511-D516	9A08878200	DIODE, 1SS133T-77
D581-D585	9A08878200	DIODE, 1SS133T-77
D901	△ 9A05194700	DIODE, 1N4003ST
D902	9A08878200	DIODE, 1SS133T-77
D903-D906	△ 9A05194700	DIODE, 1N4003ST
D911, D912	9A08878200	DIODE, 1SS133T-77
D914-D917	9A08878200	DIODE, 1SS133T-77
D931	9A08878200	DIODE, 1SS133T-77
D951, D952	9A08951100	DIODE, ZENER MTZJ6. 8BT
D953	9A08878200	DIODE, 1SS133T-77
ET01	9A08945000	PLATE, EARTH
ET02	9A08945100	BRACKET, PCB
ET03	9A05333900	PLATE, EARTH
F901	9A05328200	HOLDER, FUSE [US, C, E]
F902	9A05328200	HOLDER, FUSE
IC91	9A08952900	HEAT SINK
IC91	△ 9A07898500	IC, KA7812-ABTU
IC92	9A08952900	HEAT SINK
IC92	△ 9A08953100	IC, KA7912-ABTU
IC93	9A08953200	HEAT SINK
IC93	△ 9A08218600	IC, KA7805-ABTU
IC95	△ 9A08218600	IC, KA7805-ABTU
IC96	9A08945500	IC, NJM2296M
JK93	9A08956300	TERMINAL, SPEAKER
JK94	9A08956400	JACK, LINE IN TERMINAL
JK97	9A07427800	JACK, VCR
JK98	9A08945800	JACK, BOARD
L501-L505	9A08946000	COIL, SPEAKER
OL01	△ 9A08946100	OUTLET, 2P [US, C]
OL91	△ 9A08957100	OUTLET, 2P [E]

**MAIN PCB ASSY**

REF. NO.	PARTS NO.	DESCRIPTION
Q511-Q520	9A08951200	TR, KTA1268GRT
Q541-Q545	9A08951200	TR, KTA1268GRT
Q556-Q565	9A08951300	TR, KTC3200GRT
Q581-Q585	9A08951200	TR, KTA1268GRT
Q611-Q615	9A08952400	TR, KTD600K
Q621-Q625	9A08946200	TR, 2SA13600
Q626-Q630	9A08946300	TR, 2SC34230
Q642-Q645	△ 9A08946400	TR, KTD2061Y
Q646-Q650	△ 9A08946500	TR, KTB1369Y
Q656	△ 9A08946400	TR, KTD2061Y
Q657-Q660	△ 9A08952600	TR, 2SC4468
Q661-Q665	△ 9A08952700	TR, 2SA1695
Q670	△ 9A08952600	TR, 2SC4468
Q681-Q685	9A03745000	TR, KSC2785-YTA
Q901, Q935	9A08884100	TR, KRA107M
Q938-Q940	9A08884100	TR, KRA107M
Q942, Q943	9A03745000	TR, KSC2785-YTA
Q951	9A08878300	TR, KRC107M
Q952	9A08884100	TR, KRA107M
Q953-Q956	9A07888500	TR, KTD1302T
Q969-Q973	9A07888500	TR, KTD1302T
Q991	9A08878300	TR, KRC107M
Q992	9A08884100	TR, KRA107M
RY93	△ 9A08946600	RELAY, 4A004ZU
RY94	△ 9A08946700	RELAY, 1A008ZE
R656-R660	△ 9A07331100	R, CEMENT 0.22X2 5W
R904	△ 9A06761000	R, CARBON 3.3M K 1/2W [US, C]
R905	△ 9A05338000	R, METAL 10 OHM 1W J
R907, R908	△ 9A07309700	R, METAL 470 OHM 1W J
R958, R959	△ 9A08946800	R, CARBON 120 OHM 1/2W J
R993-R997	△ 9A05338000	R, METAL 10 OHM 1W J
TH91	9A08039800	THERMAL SENSOR, POSISTOR
T901	△ 9A08956600	TRANSFORMER, SUB [US, C]
T901	△ 9A08956610	TRANSFORMER, SUB [E, UK]

**INCLUDED ACCESSORIES**

REF. NO.	PARTS NO.	DESCRIPTION	REMARKS
	9A08584400	OWNER' S MNL, E/F [US, C]	
	9A08523500	OWNER' S MNL, E/F/G/I/S [E, UK(B)]	
	9A08688800	OWNER' S MNL, E/F [UK(N)]	
	9A08763300	REMOTE CONTROL UNIT, UR-417	
	9A08886100	AM LOOP ANTENNA ASSY [US, C]	
	9A08880900	AM LOOP ANTENNA ASSY [E, UK]	
	9A08886000	ANT, FM T [US, C]	
	9A04883100	ANT, FM WIRE [UK]	

# TEAC SCHEMATIC DIAGRAM AG-D9260

1 2 3 4 5 6 7 8

A  
B  
C  
D  
E

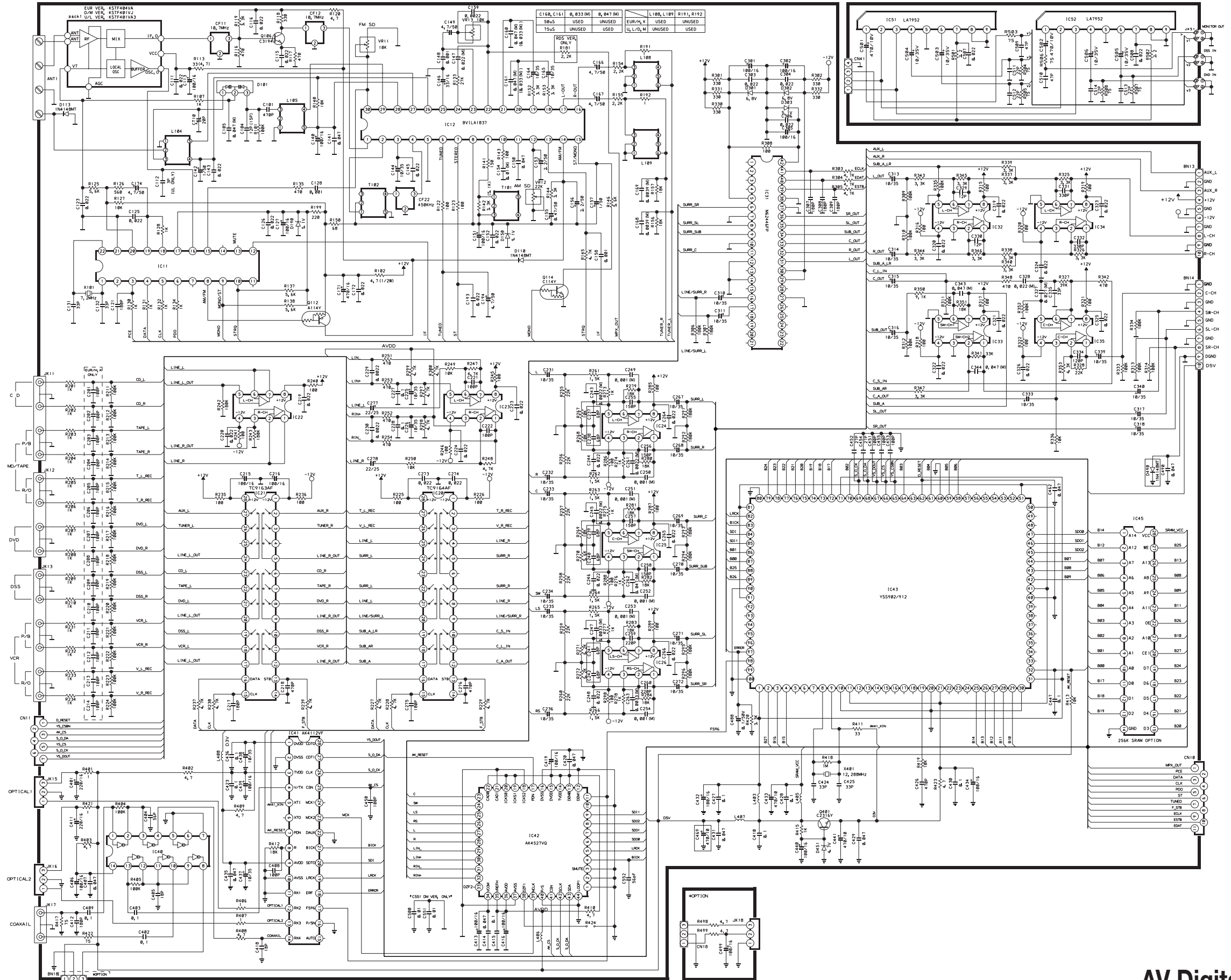

- NOTES:**
1. Resistor values are in ohms (k=kilo-ohms, M=megohms).
  2. Capacitor values are in microfarads (p=picofarads).
  3.  $\Delta$  Parts marked with this sign are safety critical components. They must always be replaced with identical components—refer to the appropriate parts list and ensure exact replacement.

# AG-D9260

## AV Digital Home Theater Receiver

1st Issue; June 2001

# TEAC SCHEMATIC DIAGRAM AG-D9260

1 2 3 4 5 6 7 8

A  
B  
C  
D  
E

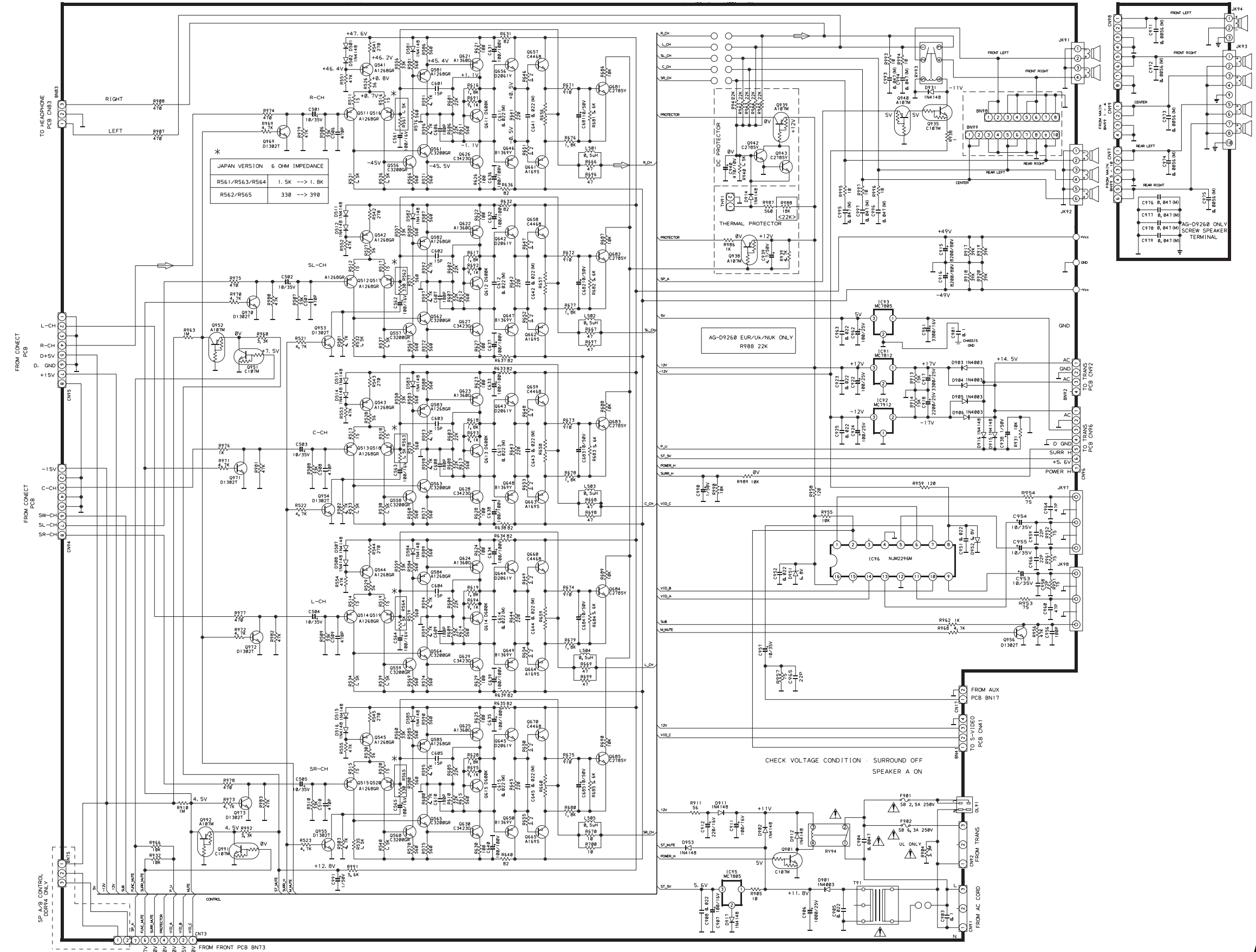

JAPAN VERSION 6 OHM IMPEDANCE

R561/R563/R564	1.5K → 1.8K
R562/R565	330 → 390

- NOTES:**
1. Resistor values are in ohms (k=kilo-ohms, M=megohms).
  2. Capacitor values are in microfarads (μ=picofarads).
  3. ⚠ Parts marked with this sign are safety critical components. They must always be replaced with identical components—refer to the appropriate parts list and ensure exact replacement.

# AG-D9260

AV Digital Home Theater Receiver

1st Issue; June 2001

# TEAC SCHEMATIC DIAGRAM AG-D9260

1 2 3 4 5 6 7 8

A  
B  
C  
D  
E

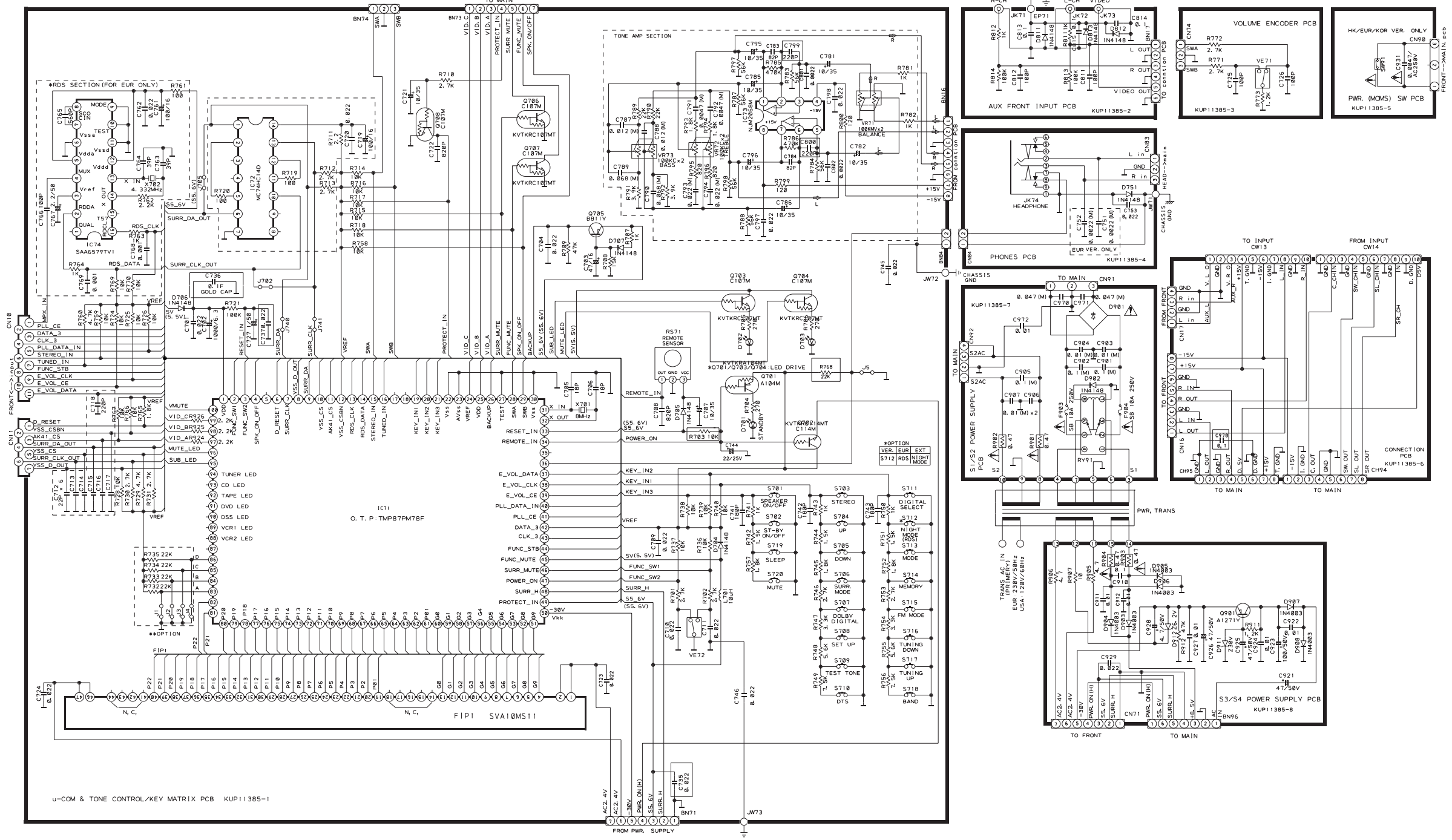

\*\*OPTION

A	H	AM/FM 9/50kHzSTEP	EUR/UK/NAK
(L1)	L	AM/FM 10/100kHzSTEP	T/C
B	H	RDS ON (R733 USE)	EUR/UK/NAK
(L2)	L	RDS OFF (J2 USE)	T/C DM EXT
C	H	JAPAN BAND ON	DM ONLY
(L3)	L	JAPAN BAND OFF	EXCEPT DM
D	H	DTS OFF (R735 USE)	ALL
(L4)	L	DTS ON (J4 USE)	ALL

**NOTES:**

- Resistor values are in ohms (k=kilo-ohms, M=megohms).
- Capacitor values are in microfarads (p=picofarads).
- Parts marked with this sign are safety critical components. They must always be replaced with identical components-refer to the appropriate parts list and ensure exact replacement.

**INSTRUCTIONS FOR SERVICE PERSONNEL**  
 BEFORE RETURNING APPLIANCE TO THE CUSTOMER, MAKE LEAKAGE-CURRENT OR RESISTANCE MEASUREMENTS TO DETERMINE THAT EXPOSED PARTS ARE ACCEPTABLY INSULATED FROM THE SUPPLY CIRCUIT.

# AG-D9260

## AV Digital Home Theater Receiver

1st Issue; June 2001