

# TEAC®

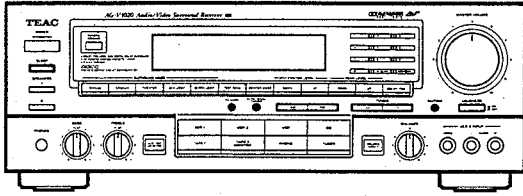

## SERVICE MANUAL

# AG-V3020

Audio/Video Surround Receiver

### NOTES

- PC boards shown are viewed from parts side.
- Parts marked with \* require longer delivery time.
- The parts with no reference number or no parts number in the exploded views are not supplied.
- As regards the resistors and capacitors, refer to the circuit diagrams contained in this manual.
- ⚠ Parts marked with this sign are safety critical components. They must be replaced with identical components - refer to the appropriate parts list and ensure exact replacement.
- Parts of [ ] mark can be used only with the version designated.  
[J]: JAPAN [US]: U. S. A. [C]: CANADA [GE]: GENERAL EXPORT  
[E]: EUROPE [UK]: U. K. [A]: AUSTRALIA

# 1. SPECIFICATIONS

## Amplifier Section

### Output Power:

**Front:** F.T.C. Rating: 100 watts RMS per channel minimum, both channels driven into 8 ohms from 20 Hz to 20 kHz with no more than 0.07% total harmonic distortion (U.S.A./Canada)

**RMS Power (20 Hz - 20 kHz):**

95 watts/8 ohms 0.07 % (Europe)

100 watts/8 ohms 0.07 % (General Export)

**DIN power:** 115 watts/8 ohms (Europe)

**Rear:** 17 watts RMS per channel minimum, both channels driven into 8 ohms from 80 Hz to 7 kHz with no more than 0.7% total harmonic distortion.

**Center:** 28 watts RMS minimum, driven into 8 ohms from 50 Hz to 15 kHz with no more than 0.07% total harmonic distortion.

### Total Harmonic Distortion (Front):

0.01% (at 100 watts, 1 kHz)

### Intermodulation Distortion (Front):

0.02% (at 100 watts)

### Surround Mode:

Delay Time:

DOLBY PRO LOGIC: 15 to 30 ms (5 ms steps)

THEATER: 5 to 40 ms (5 ms steps)

STADIUM: 5 to 40 ms (5 ms steps)

### Input Sensitivity/Impedance:

PHONO (MM): 2.5 mV/47 k ohms

LINE\*: 150 mV/47 k ohms

### Frequency Response:

30 Hz - 20 kHz  $\pm 1$  dB (PHONO)

10 Hz - 60 kHz -3 dB (LINE\*)

### Signal-to-Noise Ratio:

PHONO (MM): 73 dB

LINE\*: 94 dB

### Tone Control:

Bass:  $\pm 10$  dB at 100 Hz

Treble:  $\pm 10$  dB at 10 kHz

## FM Tuner Section

(without notes 98.1 MHz 65 dBf)

### Tuning Range:

87.5 MHz - 108.0 MHz (100 kHz steps)

(U.S.A./Canada)

87.50 MHz - 108.00 MHz (50 kHz steps)

(Europe/General Export)

### Usable Sensitivity (IHF):

Mono: 10.8 dBf (U.S.A./Canada/General Export)

Mono: 13 dBf (Europe)

### 50 dB Quieting Sensitivity:

Mono: 18 dBf/Stereo 38 dBf

(U.S.A./Canada/General Export)

Mono: 20 dBf/Stereo 42 dBf (Europe)

### Capture Ratio:

1.5 dB (U.S.A./Canada)

2.5 dB (Europe/General Export)

### Image Rejection Ratio:

55 dB (U.S.A./Canada/General Export)

80 dB (Europe)

### AM Suppression Ratio: 60 dB

RF Intermodulation: 65 dB

Total Harmonic Distortion (1 kHz):

Mono: 0.2%/Stereo 0.4%

Frequency Response:

30 Hz - 15 kHz  $\pm 1$  dB

Stereo Separation (1 kHz): 45 dB

Signal-to-Noise Ratio:

Mono: 78 dB/Stereo 70 dB

## AM Tuner Section

### Tuning Range:

530 kHz - 1,710 kHz (10-kHz steps)

(U.S.A./Canada)

522 kHz - 1,611 kHz (9-kHz steps)

(Europe/General Export)

### Usable Sensitivity:

52 dB/m

### Total Harmonic Distortion:

0.6% at 85 dB/m

### Signal-to-Noise Ratio:

50 dB at 85 dB/m

## Video Section

### Input Sensitivity/Impedance:

1.0 Vp-p/75 ohms

### Output Level/Impedance: 1.0 Vp-p/75 ohms

Frequency Response: 5 to 6 MHz (-3 dB)

Signal-to-Noise Ratio: 60 dB (1 kHz, HPF IN)

## General

### Power Requirements:

120 V AC, 60 Hz (U.S.A./Canada)

230 V AC, 50 Hz (Europe)

120/230 V AC, 50/60 Hz (General Export)

### Power Consumption:

2.7 A (U.S.A./Canada)

620 W (Europe/General Export)

### AC Outlet:

Switched x 2, Total 100 W max. (1 A max.)

(U.S.A./Canada)

Switched x 1, 100 W max.

(Europe/General Export)

### Dimensions (WxHxD): 435 x 156 x 380 mm

(17-1/8" x 6-1/8" x 14-15/16")

### Weight (net): 13 kg (28-11/16 lbs.)

### Standard Accessories:

AM Loop Antenna x 1

FM "T" Type Antenna x 1

Remote Control Unit (UR-404) x 1

Battery ("AA", "R06", SUM-3) x 2

Matching Transformer (300 ohms to 75 ohms)

(Europe) x 1

AC Plug Adapter (General Export) x 1

\* LINE means CD, VCR 1, VCR 2, VDP, TAPE 1, and TAPE 2.

• Improvements may result in specifications and features changing without notice.

• Illustrations may differ slightly from production models.

## 2. ADJUSTMENTS AND CHECKS

### 2-1. AM OSC. TRACKING ADJUSTMENT

1. Set the unit to "AM" position.
2. Connect the DC Voltmeter to TP1 in Fig. 2-4.
3. Place the radio frequency display to 530 kHz (522 kHz for General Export).
4. Adjust L102 core until DC Voltmeter indicates DC  $1.2V \pm 0.2V$ .
5. Place the radio frequency display to 1,710 kHz (1,611 kHz for General Export).
6. Adjust TC102 until DC Voltmeter indicates DC  $9.0V \pm 0.2V$  (DC  $8.6V \pm 0.2V$  for General Export).
7. Repeat step 3, 4, 5, 6.

### 2-2. AM IF ADJUSTMENT

1. Test equipment connections are shown in Fig. 2-1.
2. Set the unit to "AM" position.
3. Place the radio frequency and signal generator setting to 1,000 kHz (999 kHz for General Export).
4. Adjust L105 for maximum output.

### 2-3. AM RF ADJUSTMENT

1. Test equipment connections are shown in Fig. 2-1.
2. Set the unit to "AM" position.
3. Place radio frequency and signal generator setting to 1,400 kHz (1,404 kHz for General Export).
4. Adjust TC101 for maximum output.
5. Place radio frequency and signal generator setting to 600 kHz (603 kHz for General Export).
6. Adjust L101 for maximum output.
7. Repeat steps 3, 4, 5, 6.

#### AM SIGNAL GENERATOR CONDITION

Modulation \_\_\_\_\_ 30%  
 Modulation frequency \_\_\_\_\_ 400 Hz

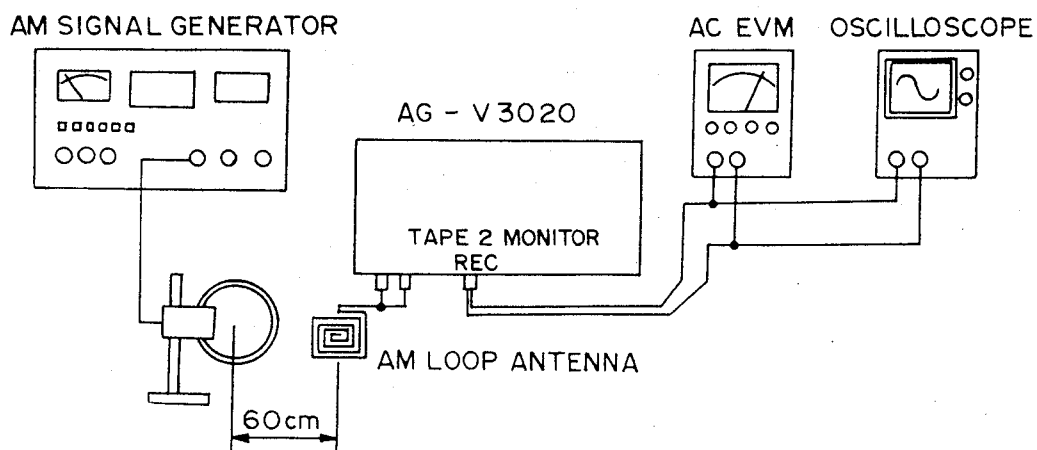

**Fig. 2-1**

### 2-4. AM TUNED LED ON LEVEL ADJUSTMENT

1. Place radio frequency and signal generator setting to 1,000 kHz (999 kHz for General Export).
2. Adjust VR101 so that "TUNED" appears in the display.

#### AM SIGNAL GENERATOR CONDITION

Output level \_\_\_\_\_ 60 dB/m

## 2-5. FM MONO IF DISTORTION ADJUSTMENT

1. Test equipment connections are shown in Fig. 2-2.
2. Set the unit to "FM" position.
3. Place the radio frequency and signal generator setting to 98.1 MHz.
4. Adjust L103 core until DC Voltmeter indicates DC  $0 \pm 50$  mV.
5. Adjust L104 core until Distortion Analyzer range indicates minimum output.
6. Repeat step 4, 5.

### FM SIGNAL GENERATOR CONDITION

Modulation \_\_\_\_\_ 100% (75 kHz dev.)  
 Modulation frequency \_\_\_\_\_ 1 kHz  
 Output level \_\_\_\_\_ 65 dBf

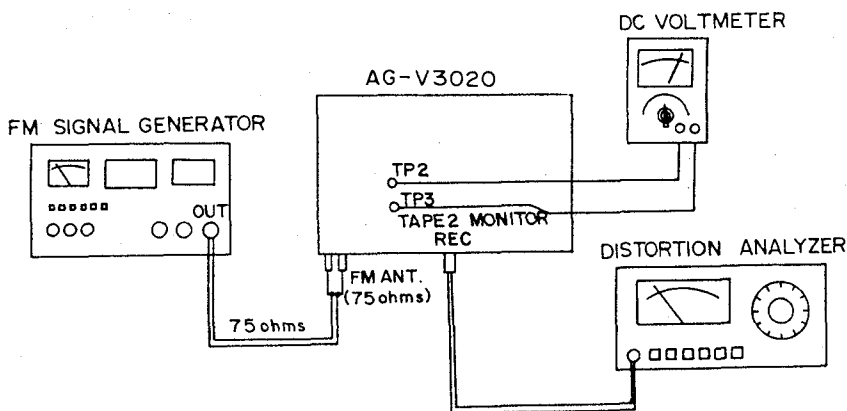

Fig. 2-2

## 2-6. FM STEREO SEPARATING ADJUSTMENT

1. Test equipment connections are shown in Fig. 2-3.
2. Set the unit to "FM STEREO" position.
3. Place the radio frequency and signal generator setting to 98.1 MHz.
4. Adjust VR103 so that R channel output is minimized when stereo modulator is in "L" (L channel modulation) mode.
5. Readjust VR103 so that L channel output is minimized when stereo modulator is in "R" (R channel modulation) mode.

### FM SIGNAL GENERATOR CONDITION

Modulation \_\_\_\_\_ "L" mode or "R" mode 45%, Pilot 10%  
 Modulation frequency \_\_\_\_\_ 1 kHz, Pilot (19 kHz)  
 Output level \_\_\_\_\_ 65 dBf

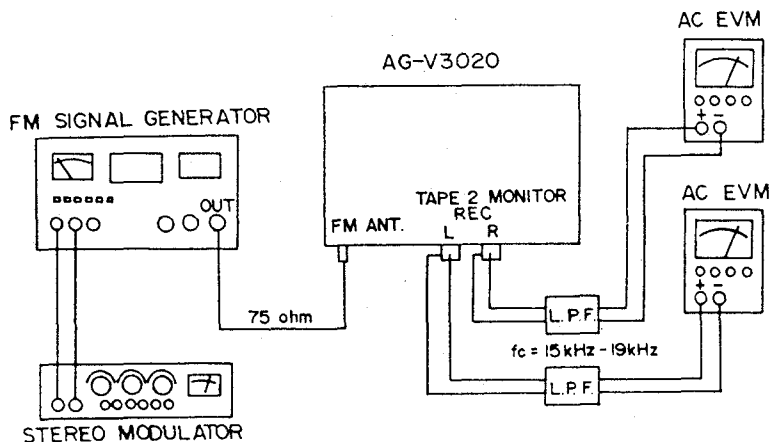

Fig. 2-3

**2-7. FM TUNED LED ON LEVEL ADJUSTMENT**

1. Place the radio frequency and signal generator setting to 98.1 MHz.
2. Adjust VR102 so that "TUNED" appears in the display.

**FM SIGNAL GENERATOR CONDITION**

Output level \_\_\_\_\_ 28 dBf

**2-8. ADJUSTMENTS AND TEST POINTS**

USA/CANADA/General Export

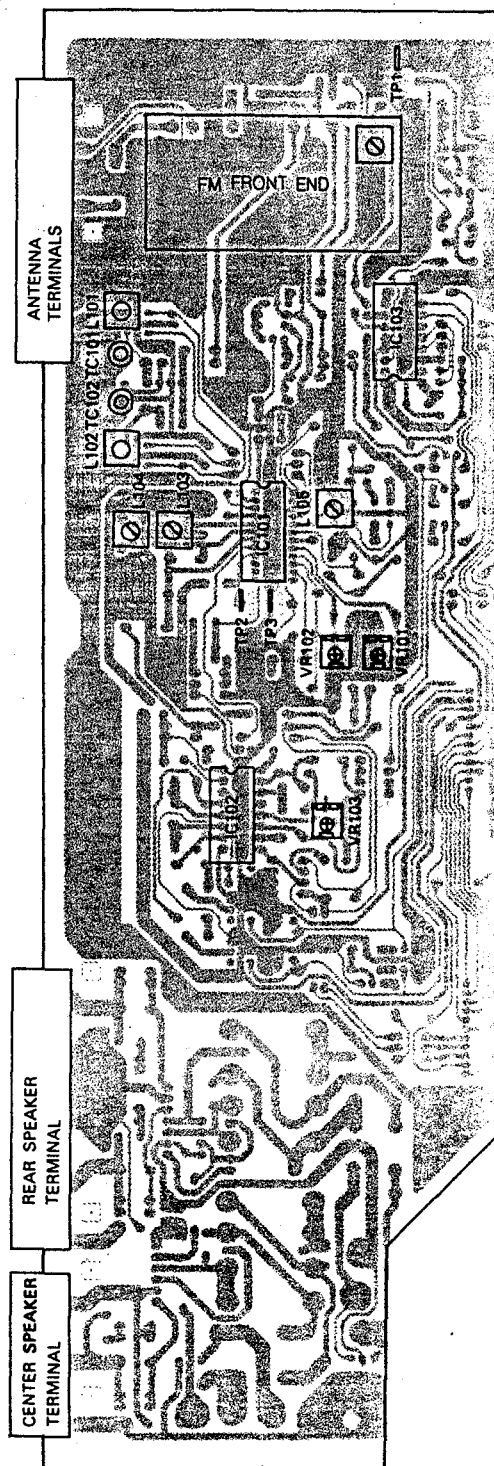
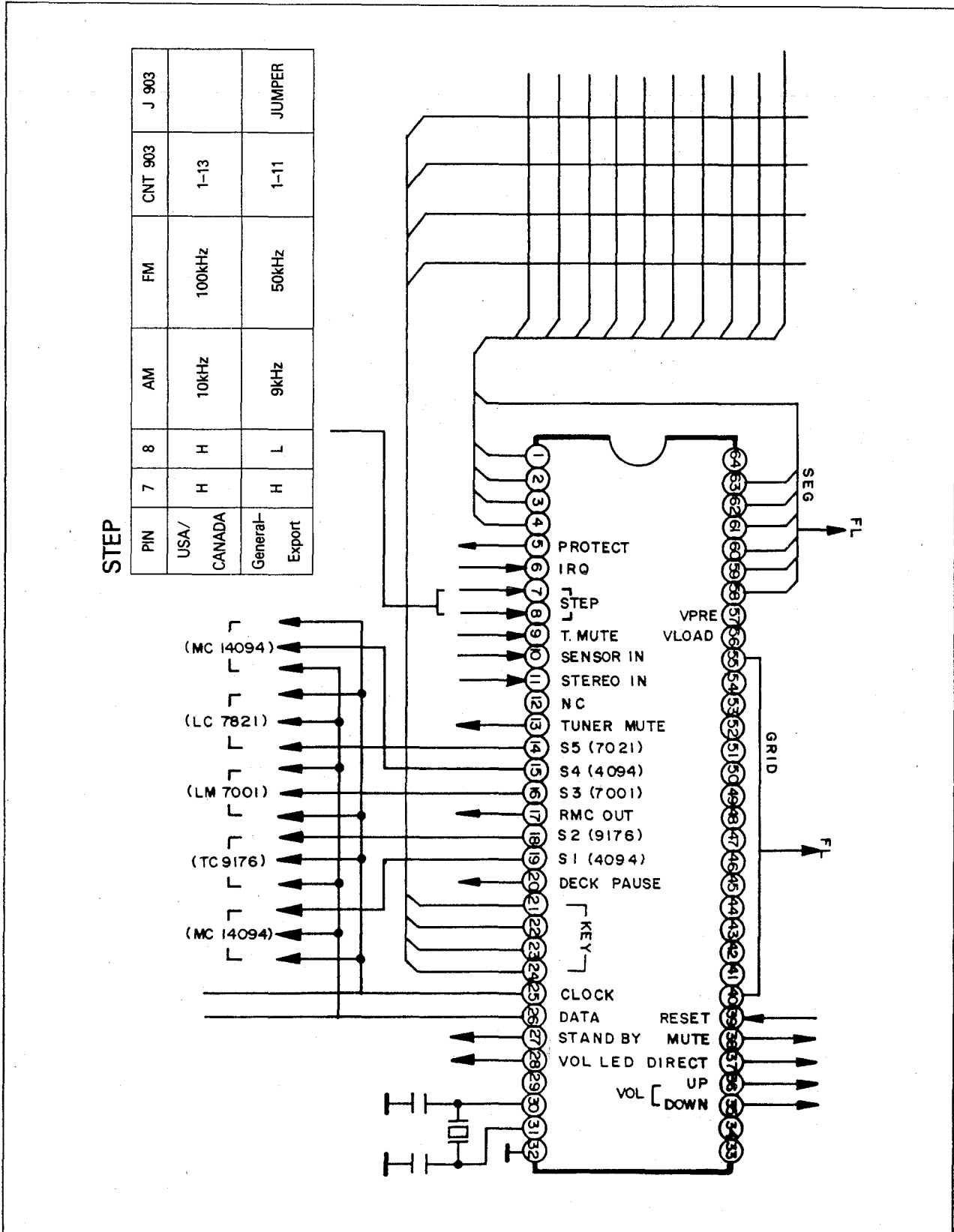





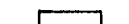
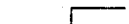

Fig. 2-4



### 3. MICROCOMPUTER (IC901: $\mu$ PD75216)

#### 3-1. Pin Assignment

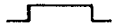
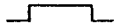

3-2. Functions Assigned

NO.	TERMINAL	OPERATING CHART	REMARKS
1	KEY MATRIX OUTPUT		S3
2	KEY MATRIX OUTPUT		S2
3	KEY MATRIX OUTPUT		S1
4	KEY MATRIX OUTPUT		S0
5	PROTECT		P01
6	IRQ		P02
7	STEP CHANGE		P03
8	STEP CHANGE		P04
9	TUNED		P10
10	SENSOR IN		P11
11	STEREO IN		P12
12	Nc		P13
13	TUNER MUTE		P20
14	STROBE		LC7821
15	STROBE		MC14094
16	STROBE (PLL)		LM7001
17	RMC OUT		
18	STROBE		TC9176
19	STROBE		MC14094
20	DECK PAUSE		
21	KEY MATRIX INPUT		
22	KEY MATRIX INPUT		
23	KEY MATRIX INPUT		
24	KEY MATRIX INPUT		
25	CLOCK		
26	DATA		
27	STAND BY		
28	VOL LED		
29	Nc		
30	X1		4.19MHz
31	X0		4.19MHz
32	Vss		

NO.	TERMINAL	OPERATING CHART	REMARKS
33	Nc		
34	Nc		
35	DOWN(VOL)		
36	UP(VOL)		
37	DIRECT		
38	MUTE		
39	RESET		
40	T0		GRID
41	T1		GRID
42	T2		GRID
43	T3		GRID
44	T4		GRID
45	T5		GRID
46	T6		GRID
47	T7		GRID
48	T8		GRID
49	T9		GRID
50	S15		SEGMENT
51	S14		SEGMENT
52	S13		SEGMENT
53	S12		SEGMENT
54	S11		SEGMENT
55	S10		SEGMENT
56	VLOAD		
57	VPRE		
58	S9		SEGMENT
59	S8		SEGMENT
60	S7		SEGMENT
61	S6		SEGMENT
62	S5		SEGMENT
63	S4		SEGMENT
64	VDD		+5V

3-3. Block Diagram

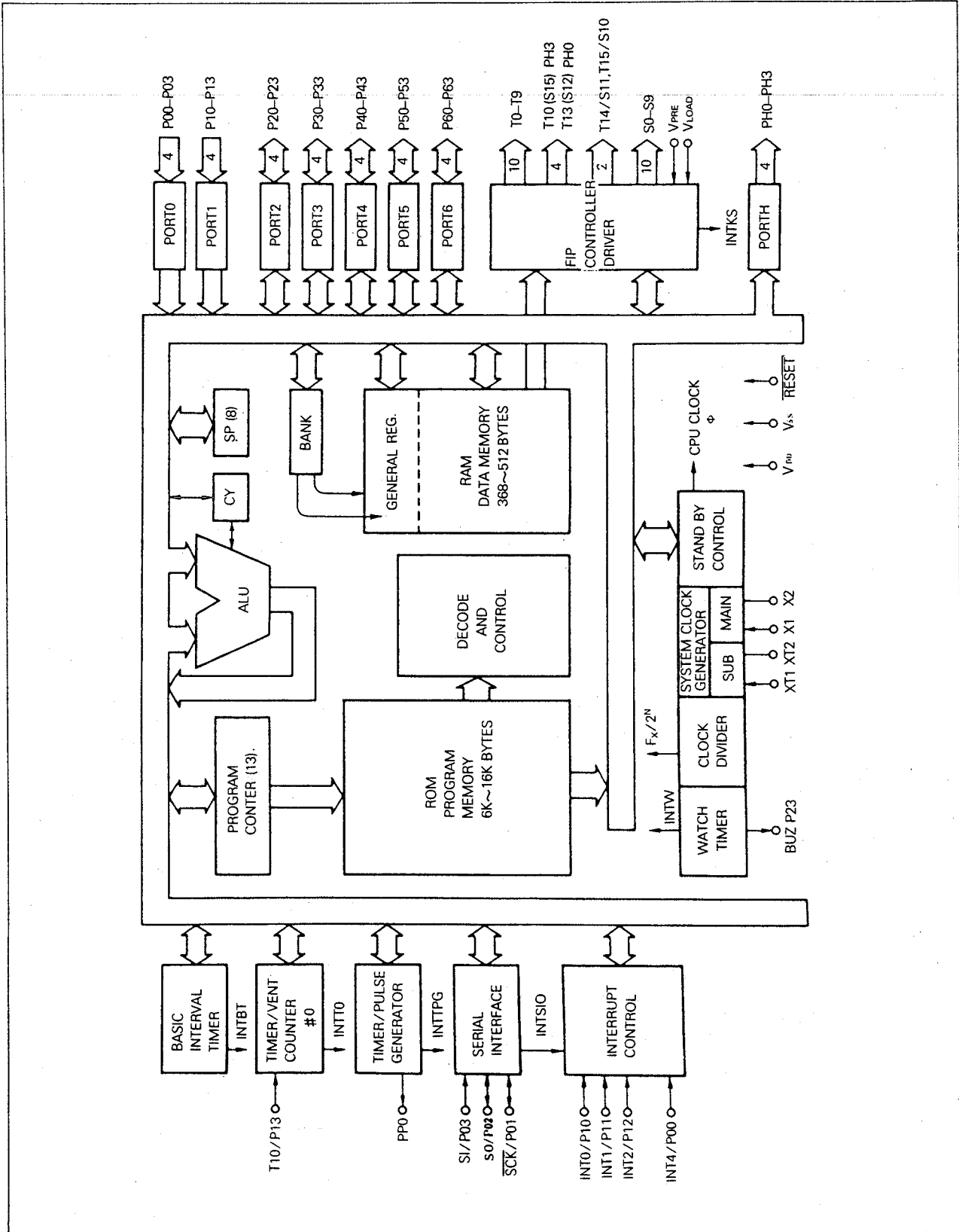



3-4. Key Matrix

		Y	Y		S11
CENTER DOWN Y	CENTER UP Y	CENTER MODE Y	TEST TONE Y		S10
VDP Y	PRESET SCAN Y	FM MODE Y	AUTO/MANUAL Y		S9
VCR 2 Y	VCR 1 REC Y	SOURCE DIRECT Y	MEMORY Y		S8
VCR 1 Y	THEATER Y	3 CH Y	DELAY TIME Y		S7
TAPE 1 Y	AM Y	FM Y	TUNE DOWN Y		S6
REAR UP Y	STADIUM Y	OFF Y	REAR DOWN Y		S5
	SLEEP Y	POWER Y	DOLBY PRO LOGIC Y		S4
TAPE (2) MON Y	1 Y	TUNE UP Y	6 Y		S3
PHONO Y	MUTE Y	5 Y	10 Y		S2
CD Y	3 Y	4 Y	9 Y		S1
TUNER Y	2 Y	7 Y	8 Y		S0
	P63	P62	P61		P60

### 4. IC BLOCK DIAGRAMS

TC9176: IC712

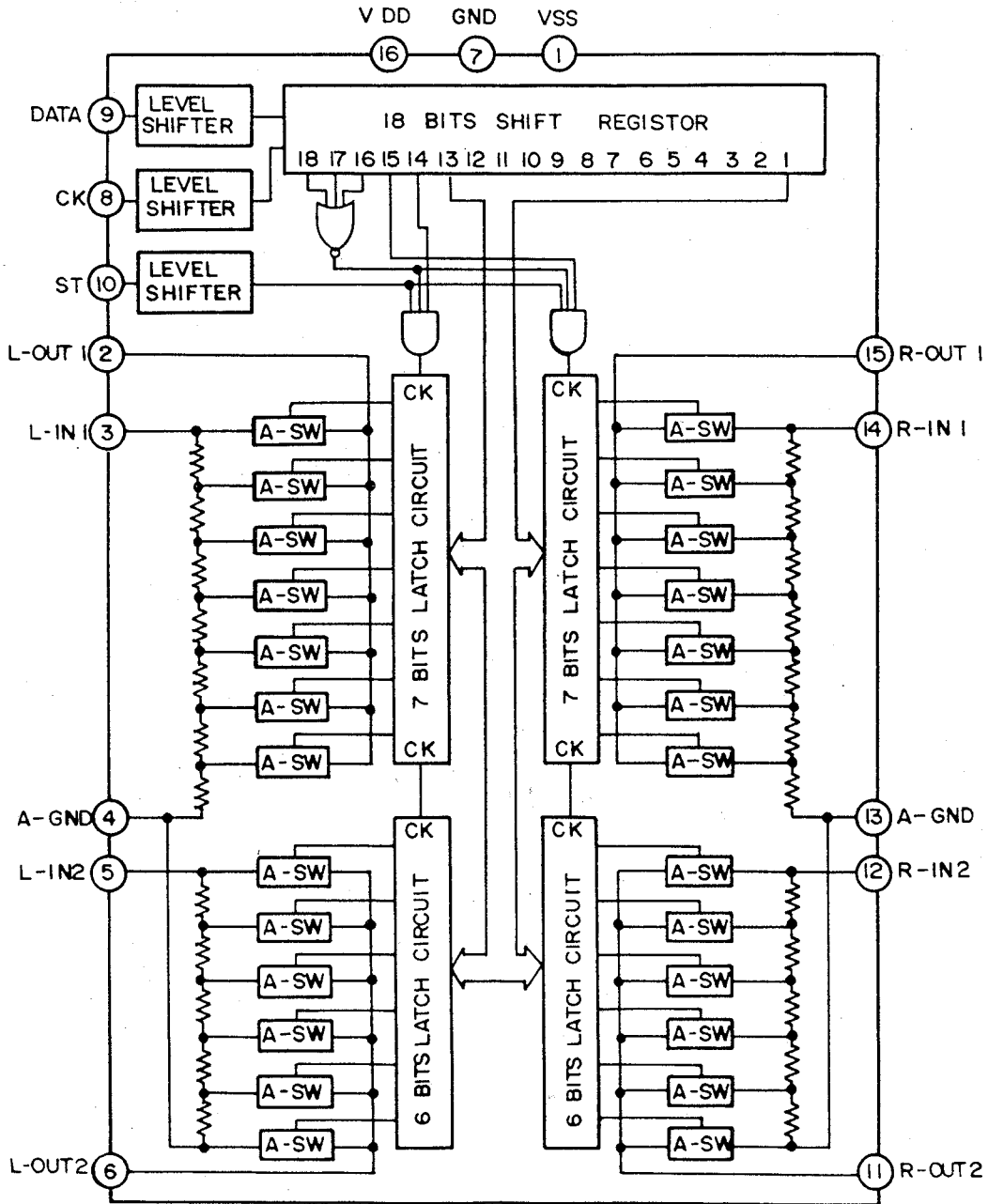
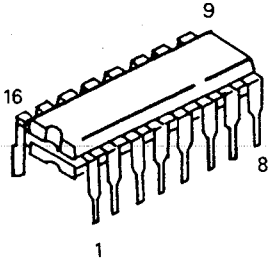

LA2730: IC710

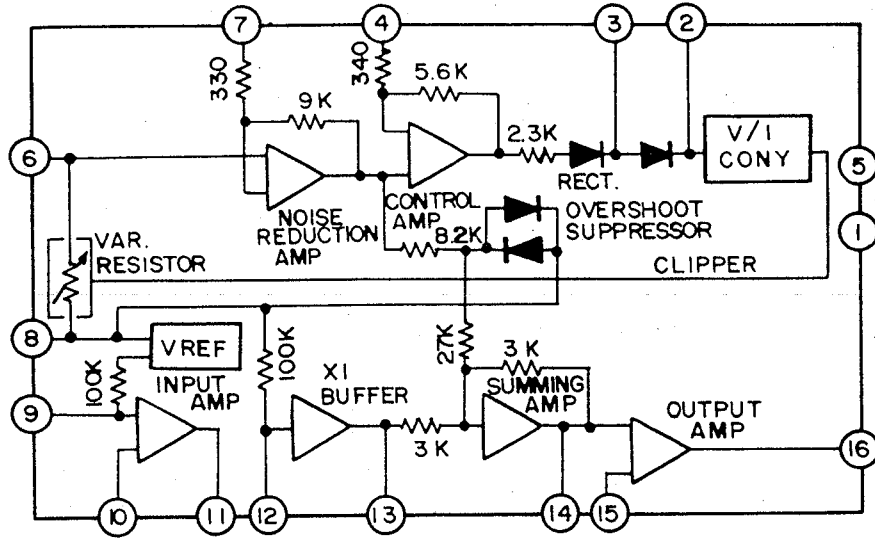
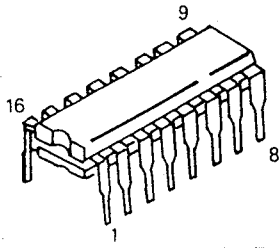

KIA4559P: IC201, IC207,  
IC702, IC703 IC701,  
IC709, IC711, IC713,  
IC401-IC403

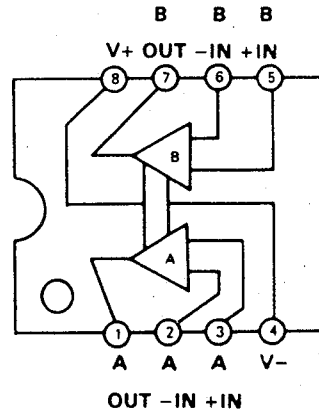
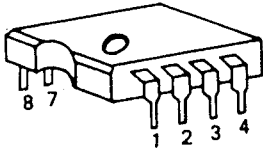

MC 14094B : IC206, IC707, IC708

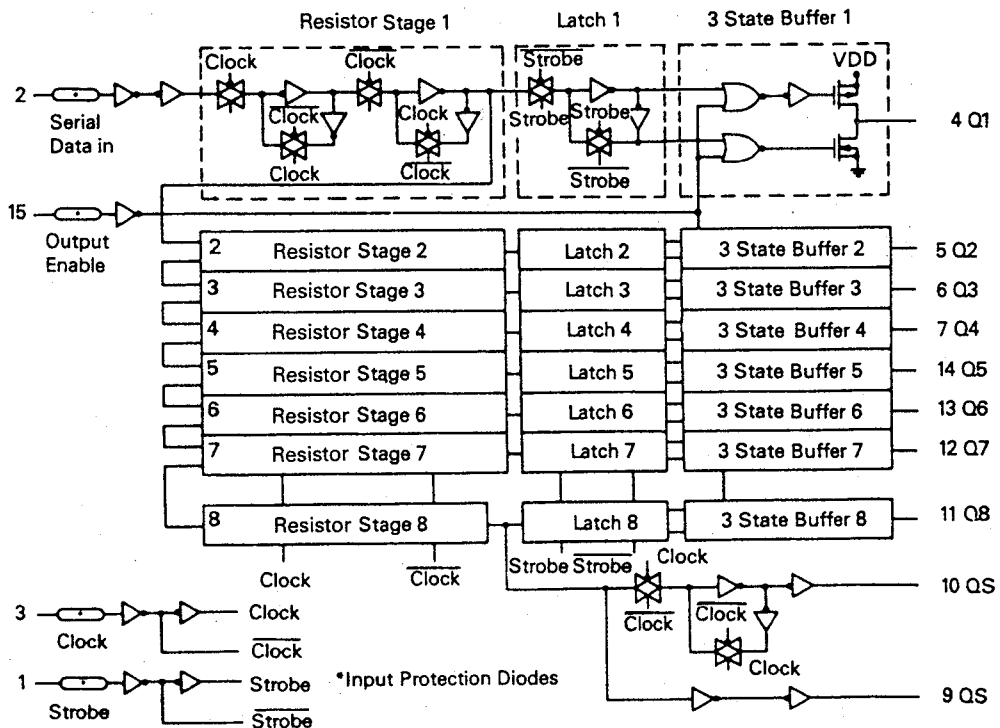

# AG-V3020

STK 4122 II: IC801

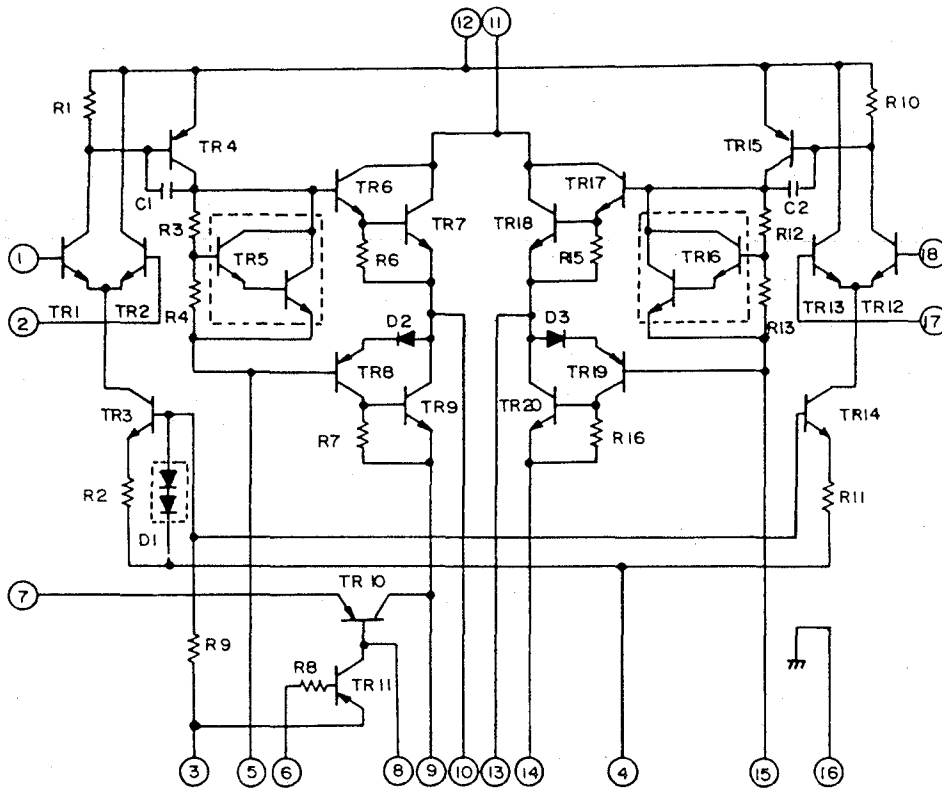

## FRONT-END : FE 306-A15 FOR(USA/CANADA/GENERAL EXPORT)Version Only

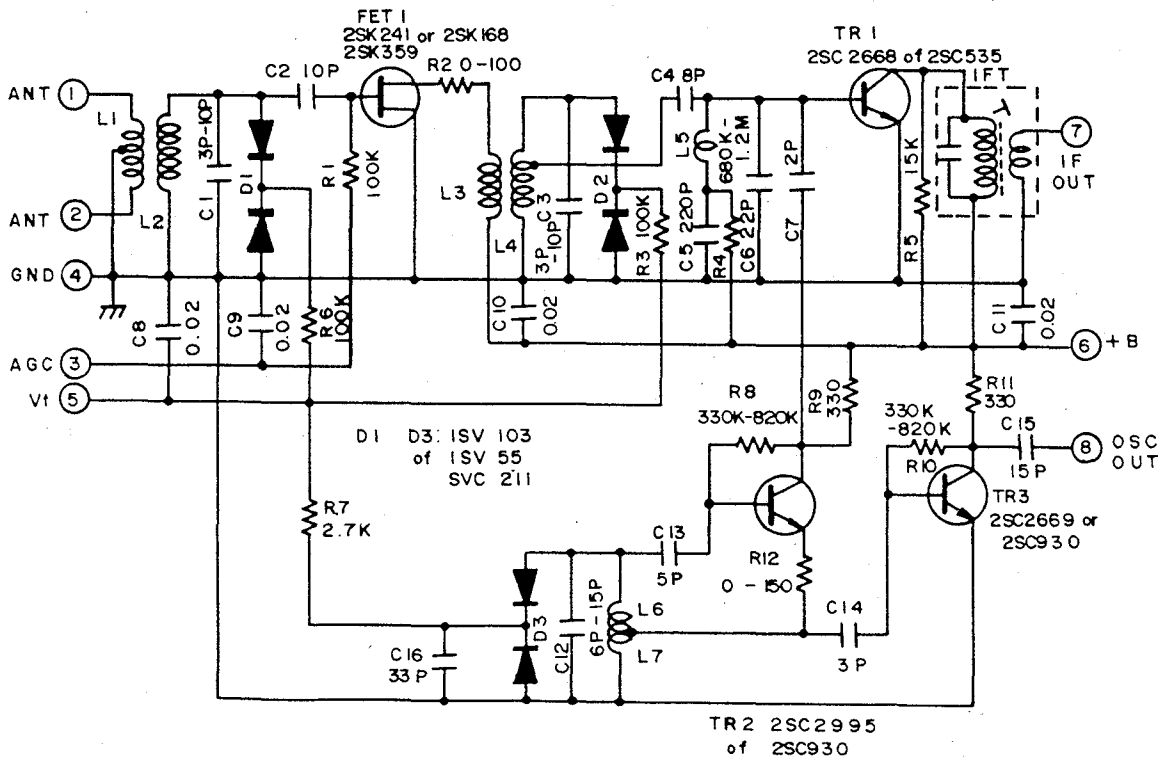

M50198P: IC706

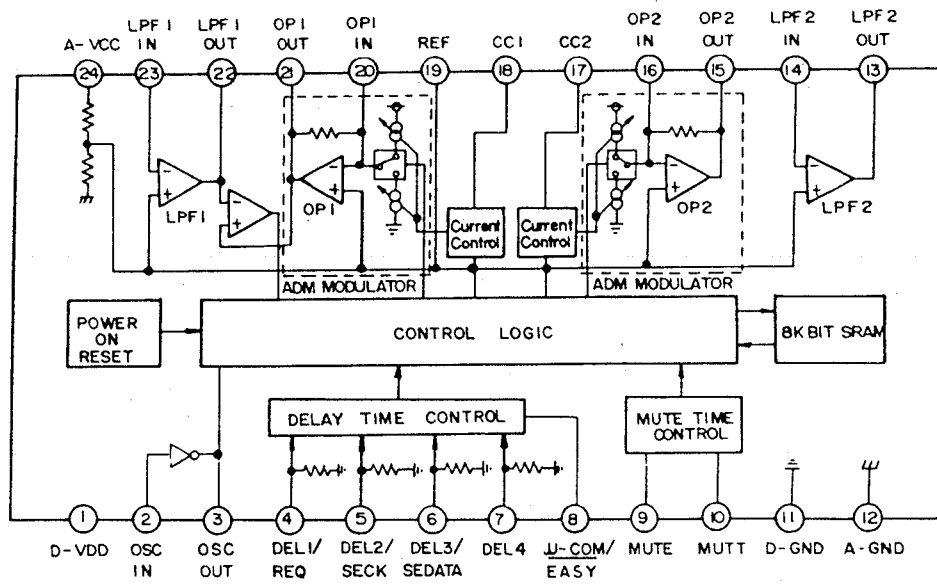
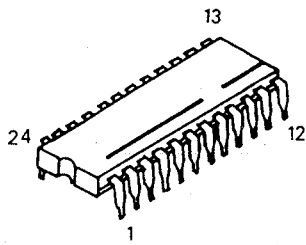

TA7291S: IC301

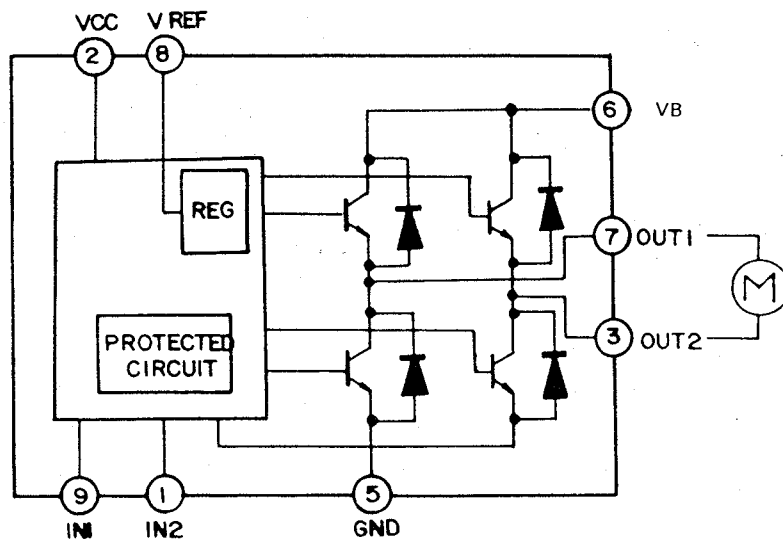
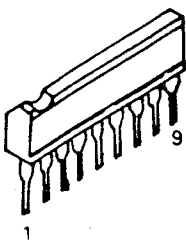

# AG-V3020

LC4966: IC704, IC705

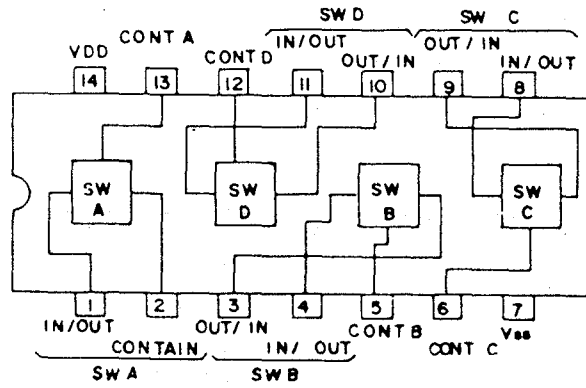
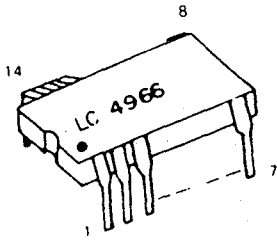

LM7001: IC103 (PLL IC)

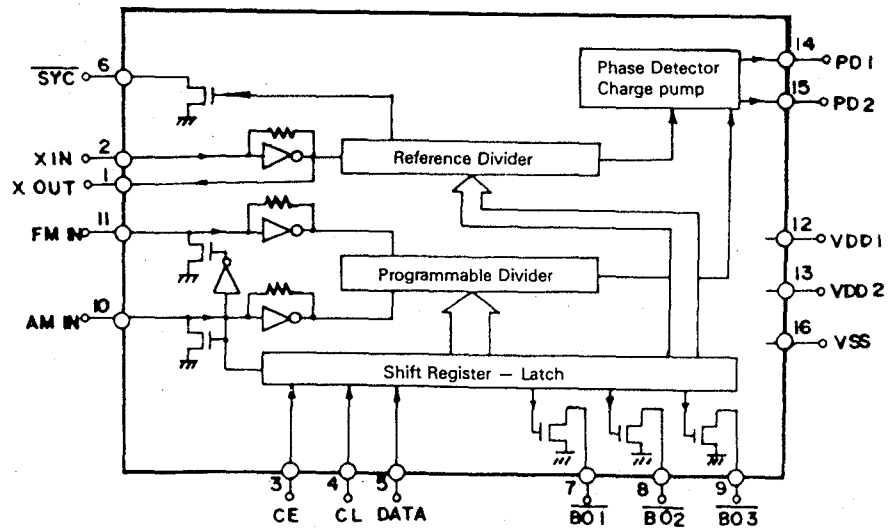

BA7625: IC205

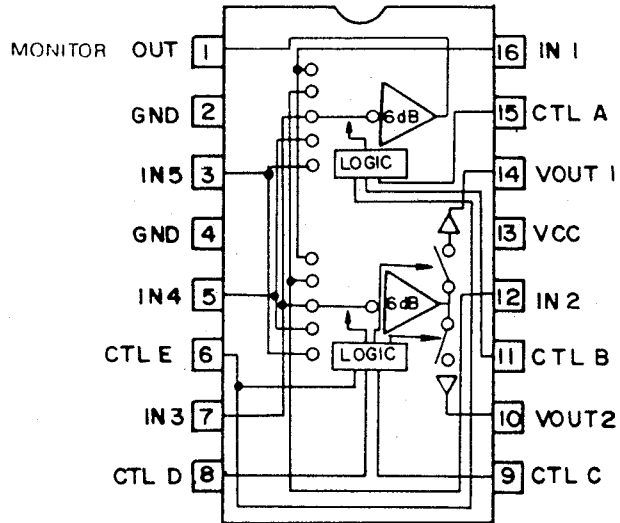
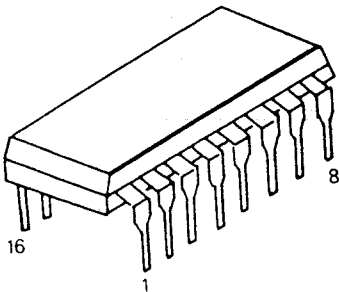

GL7915 : IC210

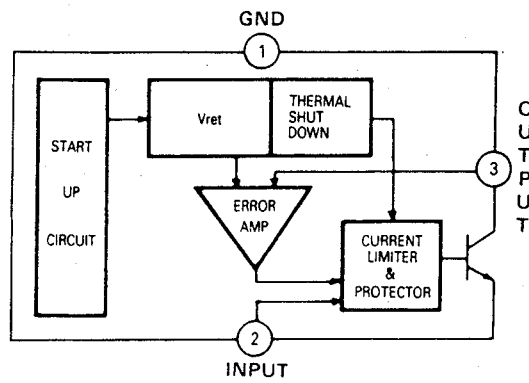
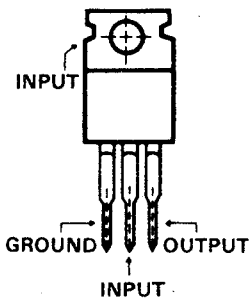

# AG-V3020

LC7821: IC203, IC204

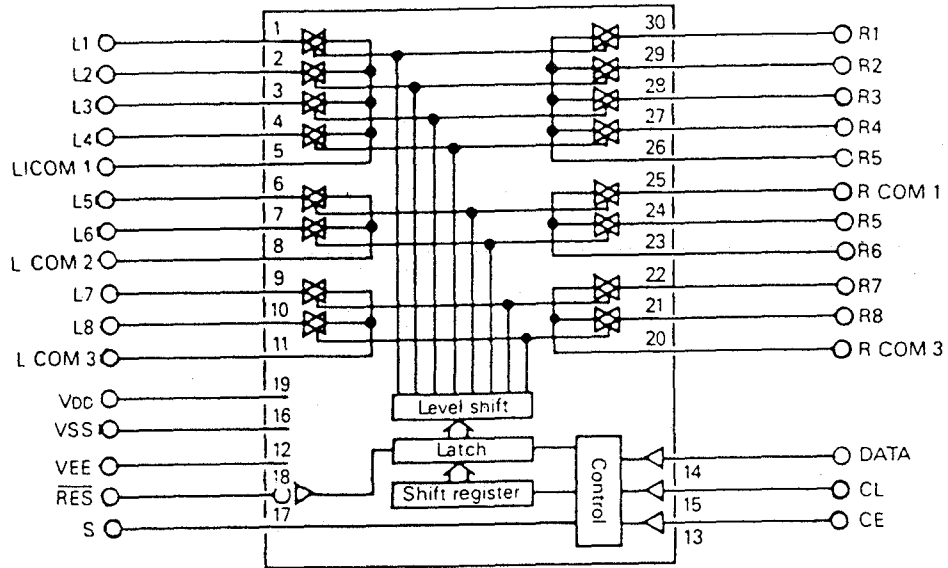
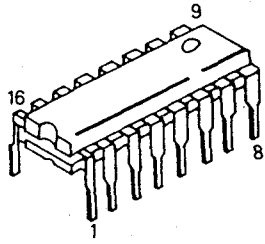

STK4026 II : IC802

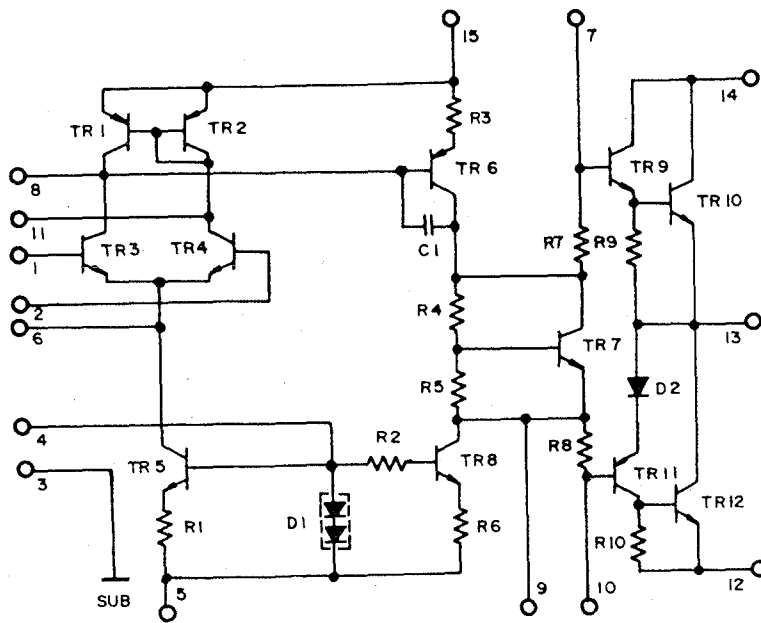
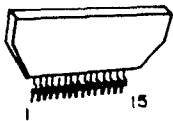

GL7805 : IC209  
GL7815 : IC211

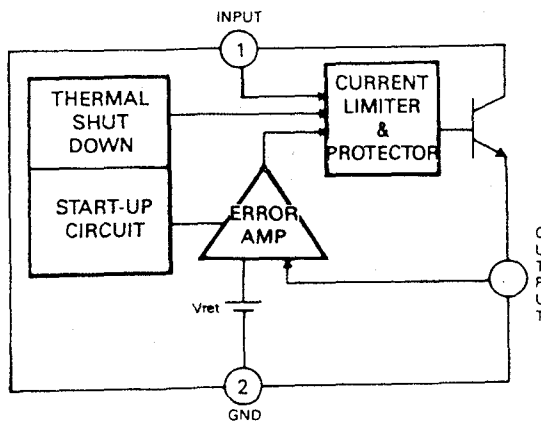
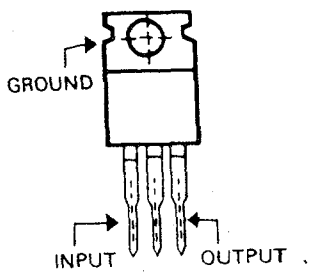



SSM2126 : IC202

Table I. Control States for DM1-DM4

DM1	DM2	DM3	DM4	Operating State
1	1	1	1	Dolby 4-Channel ('Pro-Logic'), Autbalance On
1	1	0	1	Dolby 4-Channel ('Pro-Logic'), Autbalance Off
1	0	1	1	Dolby 3-Channel ('Dolby 3'), Autbalance On
1	0	0	1	Dolby 3-Channel ('Dolby 3'), Autbalance Off
0	1	1	1	Surround Channel Noise
0	1	1	0	Right Channel Noise
0	1	0	1	Center Channel Noise
0	1	0	0	Left Channel Noise
0	0	X	1	Mute
0	0	1	0	Stereo Bypass, Autbalance On
0	0	0	0	Stereo Bypass, Autbalance Off

Table II. Center Channel Functional Modes

CM1	CM2	Mode
0	0	Center Channel Off
0	1	Center Channel Wideband
1	0	Phantom Center Channel
1	1	Normal Center Mode

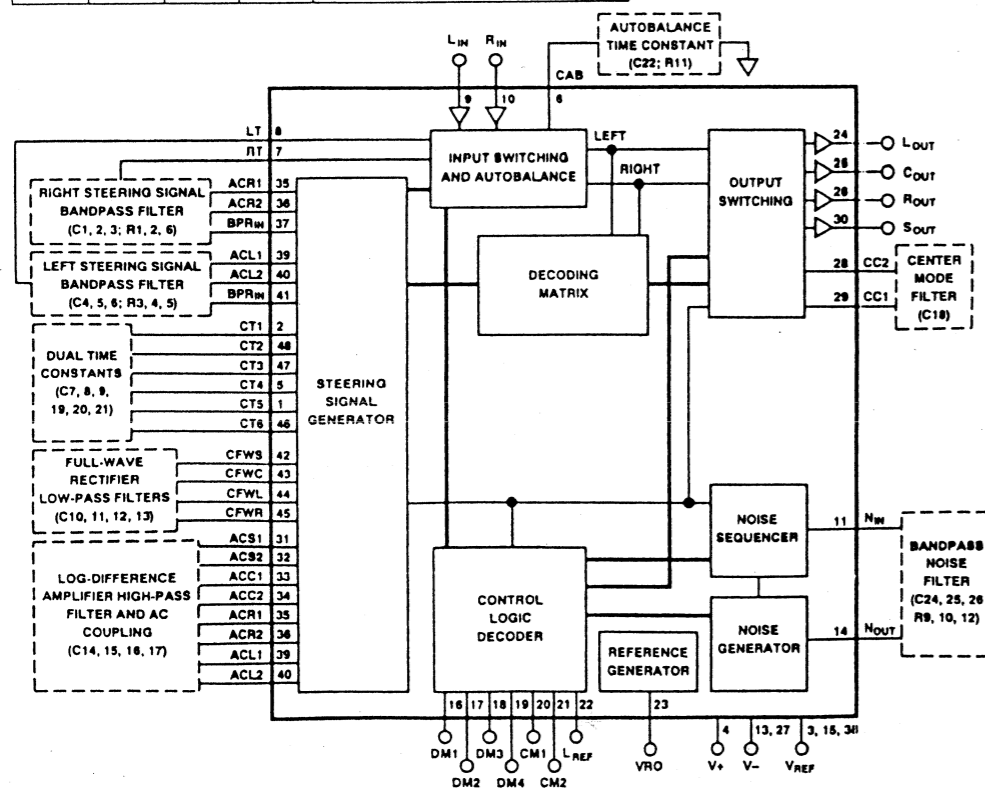

LA3410 : IC102

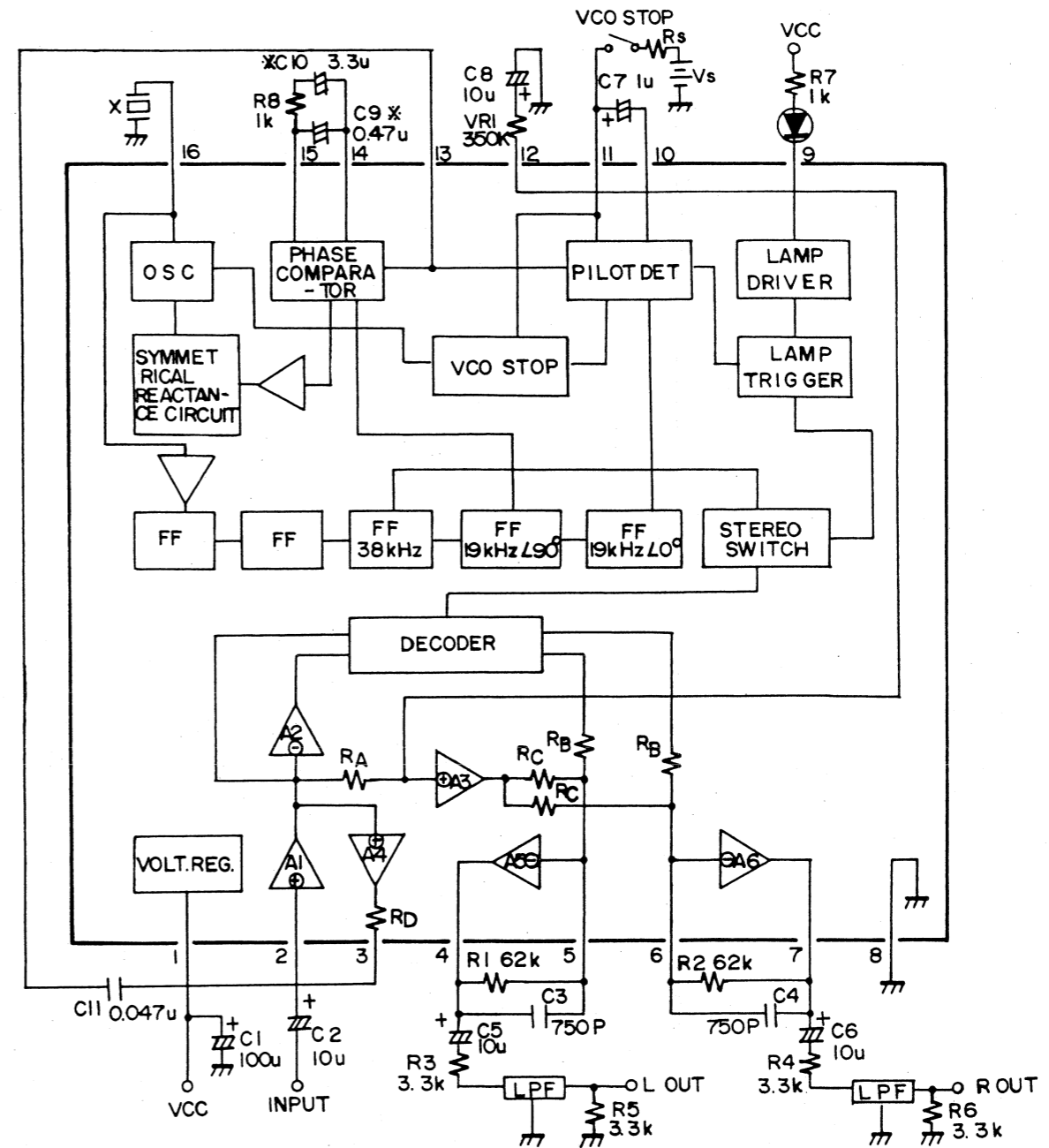

LA1266 : IC101

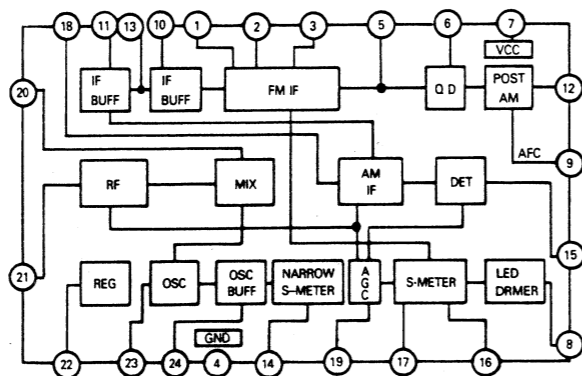
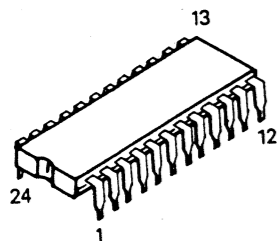

### 5. EXPLODED VIEW AND PARTS LIST

This section is applicable to the U.S.A./Canada models.

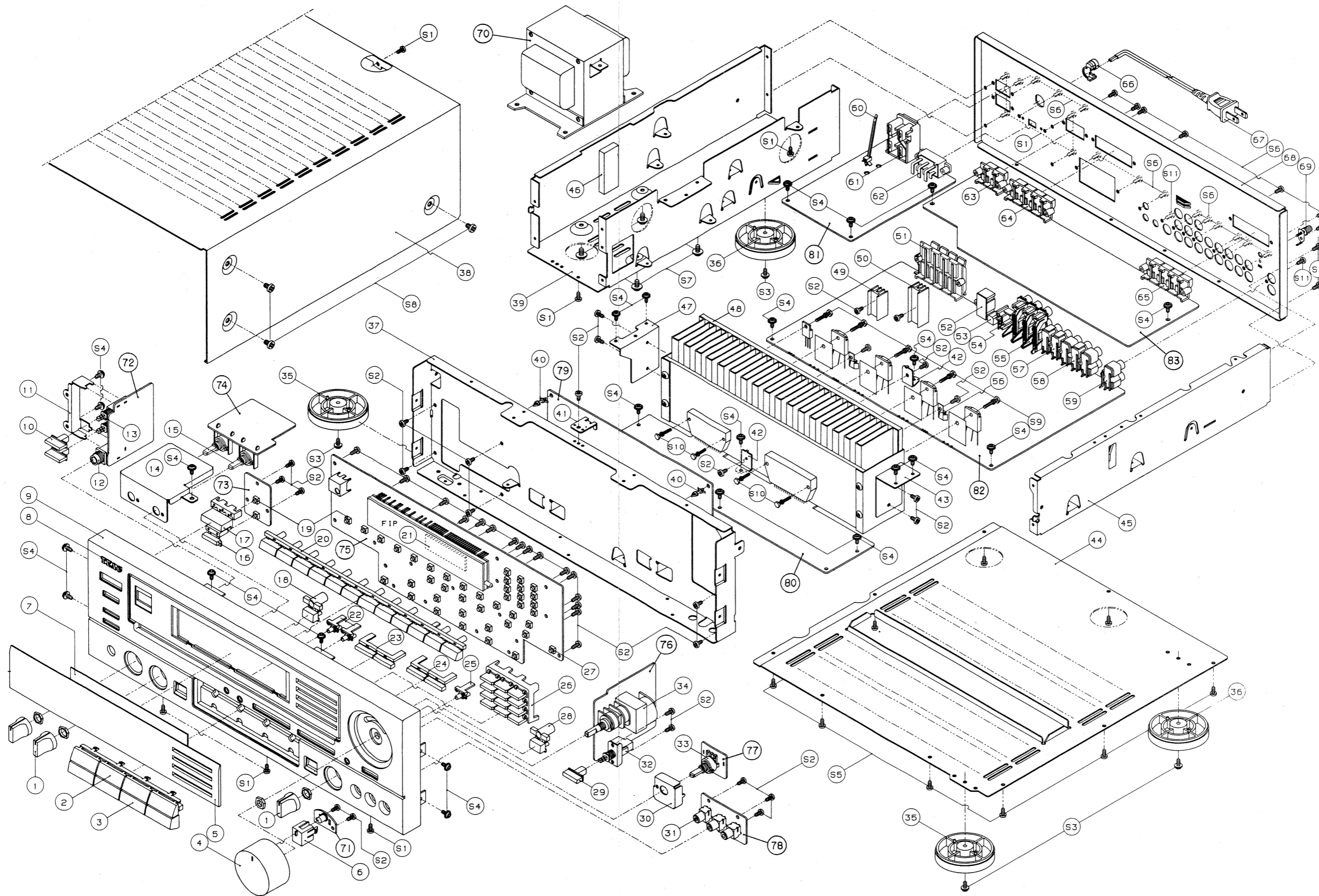

REF. NO.	PARTS NO.	DESCRIPTION	REMARKS
1	9A04192300	KNOB, VR	
2	9A04196200	BUTTON, INPUT A	
3	9A04196300	BUTTON, INPUT B	
4	9A04192400	KNOB, MAIN	
5	*9A04195600	WINDOW, DISPLAY	
6	*9A04192500	INDICATOR	
7	*9A04195800	FILTER	
8	*9A04196000	BADGE	
9	*9A04195500	PANEL, FRONT	
10	9A04197300	BUTTON, SPEAKER	
11	*9A04229100	BRACKET, PCB SPK	
12	9A04228900	JACK, PHONE GOLD	
13	9A04229000	SW, SPUL19X1M071	
14	*9A04197500	SHIELD FENCE, A	
15	9A04228100	VR, RK16K12B0Z0114B	
16	9A04197200	BUTTON, SLEEP	
17	9A04197100	BUTTON, POWER	
18	9A04196900	BUTTON, RECORD	
19	9A04220300	SW, SKHV10910D01	
20	9A04196100	BUTTON, FUNCTION	
21	*9A04303300	SPONGE, FL EVA	
22	9A04196700	BUTTON, MODE	
23	9A04196500	BUTTON, AM/FM	
24	9A04196400	BUTTON, TUNING (BLACK)	
25	9A04196800	BUTTON, MUTING (GOLD)	
26	9A04196600	BUTTON, STATION (BLACK)	
27	9A04303400	SW, TACT	
28	9A04197000	BUTTON, DIRECT	
29	9A04197400	BUTTON, LOUDNESS	
30	*9A04210800	SHIELD FENCE, B	
31	9A04210400	JACK, RCA 1P	
32	9A04229900	SW, PUSH	
33	9A04210700	VR, RK16K118000114H	
34	9A04229600	VR, MOTOR 50KA*4	
35	9A04192100	FOOT, GOLD	
36	9A04192200	FOOT, BLACK	
37	*9A04193700	FRAME, FRONT	
38	*9A04191900	COVER, TOP	
39	*9A04193500	FRAME, LEFT	
40	*9A04193800	FASTENER, KGLS-4S	
41	*9A04193900	BRACKET, PCB	
42	*9A04198200	BRACKET, HEAT SINK	
43	*9A04197900	BRACKET, HEAT SINK R	
44	*9A04192000	COVER, BOTTOM	
45	*9A04193600	FRAME, R	
46	*9A04303500	SPONGE, EVA	
47	*9A04197800	BRACKET, HEAT SINK L	
48	*9A04197700	HEAT SINK, POWER	
49	*9A04202500	HEAT SINK, REG TR	
50	*9A04202600	HEAT SINK, REG TR	
51	9A04200700	TERMINAL, SPEAKER	
52	9A04202100	JACK, LGA6502-0150	
53	9A04202000	JACK, LGA6501-0600	
54	9A04201900	JACK, RCA 1P	
55	9A04201800	JACK, RCA 3P	

REF. NO.	PARTS NO.	DESCRIPTION	REMARKS
56	*9A04198300	SPRING HOLDER, STA2170	
57	9A04201600	JACK, RCA 6P	
58	9A04201500	JACK, RCA 4P	
59	9A04201700	JACK, RCA 2P	
60	*9A04303600	LOCKING TIE, NYLON	
61	Δ *9A04227200	AC OUTLET, CCT1304-0212	
62	Δ 9A04227300	SW, SDKGA4343B (SW601)	
63	9A04213900	TERMINAL, SPEAKER 2P	
64	9A04213800	TERMINAL, PUSH 4P	
65	9A04213700	TERMINAL, PUSH 4P	
66	Δ *9A04194300	CORD, STOPPER	
67	Δ 9A04194200	AC CORD, EHD-0008-266P	
68	*9A04194000	CHASSIS, BACK	
69	9A04194100	TERMINAL, GND	
70	Δ 9A04195200	POWER TRANS. (TRANS601)	
71	*9A04210900	LED PCB ASSY	
72	*9A04228700	HEADPHONE PCB ASSY	
73	*9A04220400	POWER SW PCB ASSY	
74	*9A04228000	tone PCB ASSY	
75	*9A04218000	FRONT PCB ASSY	
76	*9A04229400	VOLUME PCB ASSY	
77	*9A04210600	BALANCE PCB ASSY	
78	*9A04210100	VCR 2 PCB ASSY	
79	*9A04223300	SURROUND PCB ASSY	
80	*9A04220800	BOTTOM PCB ASSY	
81	*9A04226300	POWER PCB ASSY	
82	*9A04199000	MAIN PCB ASSY	
83	*9A04211400	TUNER PCB ASSY	
S1	*9A04192700	SCREW, #2BTC3X8B	
S2	*9A04192700	SCREW, #2BTC3X8B	
S3	*9A04192900	SCREW, #2WPTC3X8Y	
S4	*9A04192900	SCREW, #2WPTC3X8Y	
S5	*9A04192800	SCREW, #2BTC3X6B	
S6	*9A04194500	SCREW, #1PT3X10B	
S7	*9A04303700	SCREW, WSAM M4*8Y	
S8	*9A04303800	SCREW, BSAM M4*8B	
S9	*9A04198000	HEX MSPW 3X12Y	
S10	*9A04198100	HEX MSPW 3X16(Y)	
S11	*9A04194400	SCREW, G.N.D.	

INCLUDED ACCESSORIES

REF. NO.	PARTS NO.	DESCRIPTION	REMARKS
	*9A04324100	ANTENNA, AM LOOP	
	*9A04326200	ANTENNA, FM 300 OHMS	
	*9A04191500	REMOCON UNIT, UR-404	
	9A04328200	BATTERY (AA, R06, SUM-3)	
	*9A04151100	AG-V3020 OWNER'S MANUAL (E/F)	





FRONT PCB

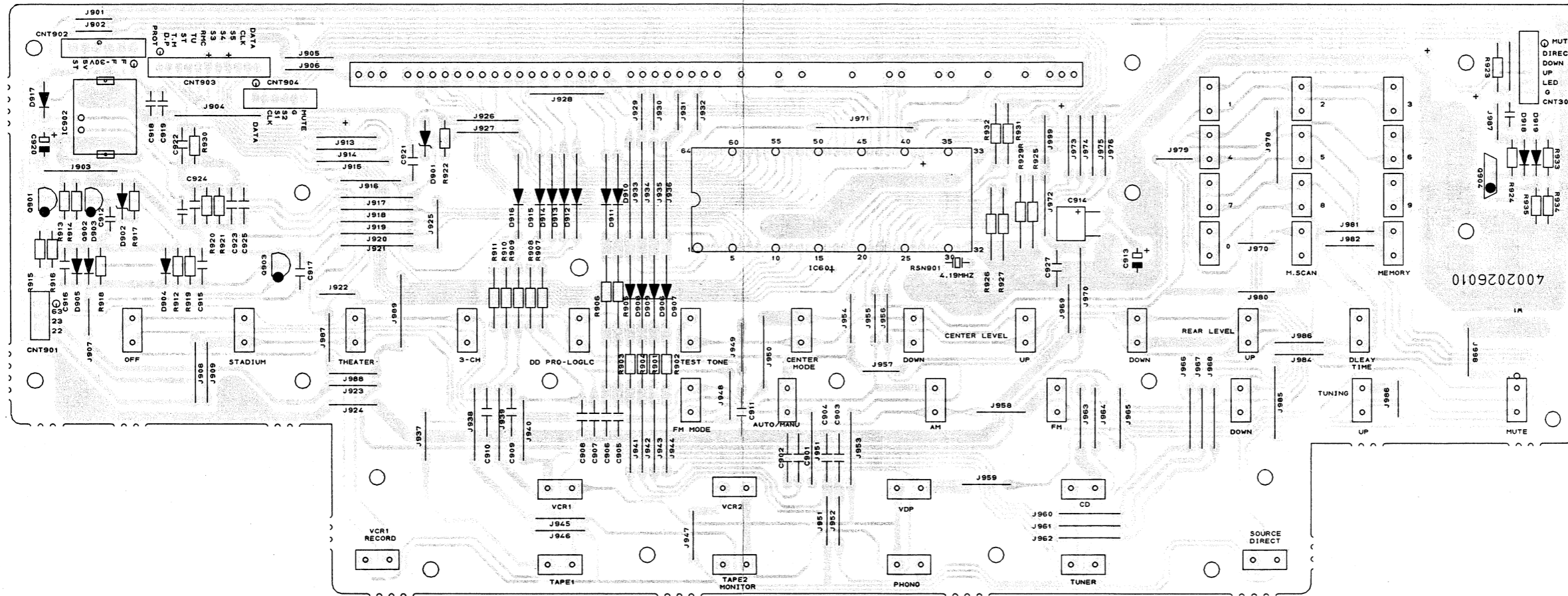

VOLUME PCB

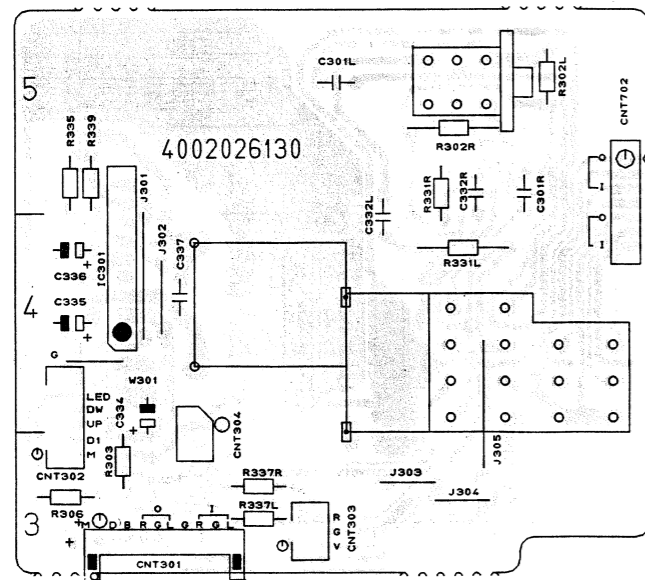

STONE PCB

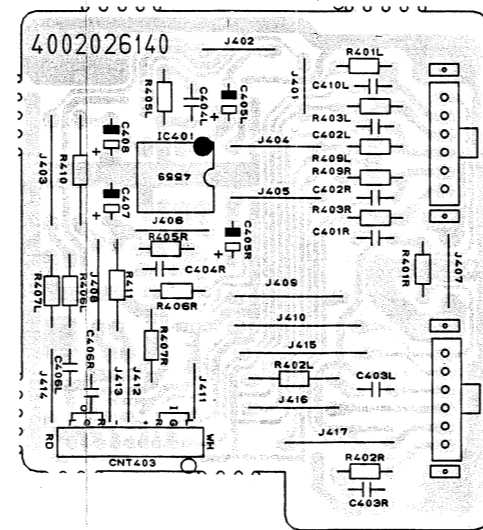

HEADPHONE PCB

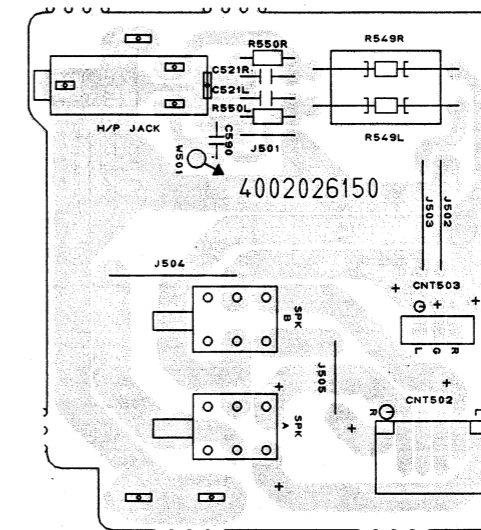

SURROUND PCB

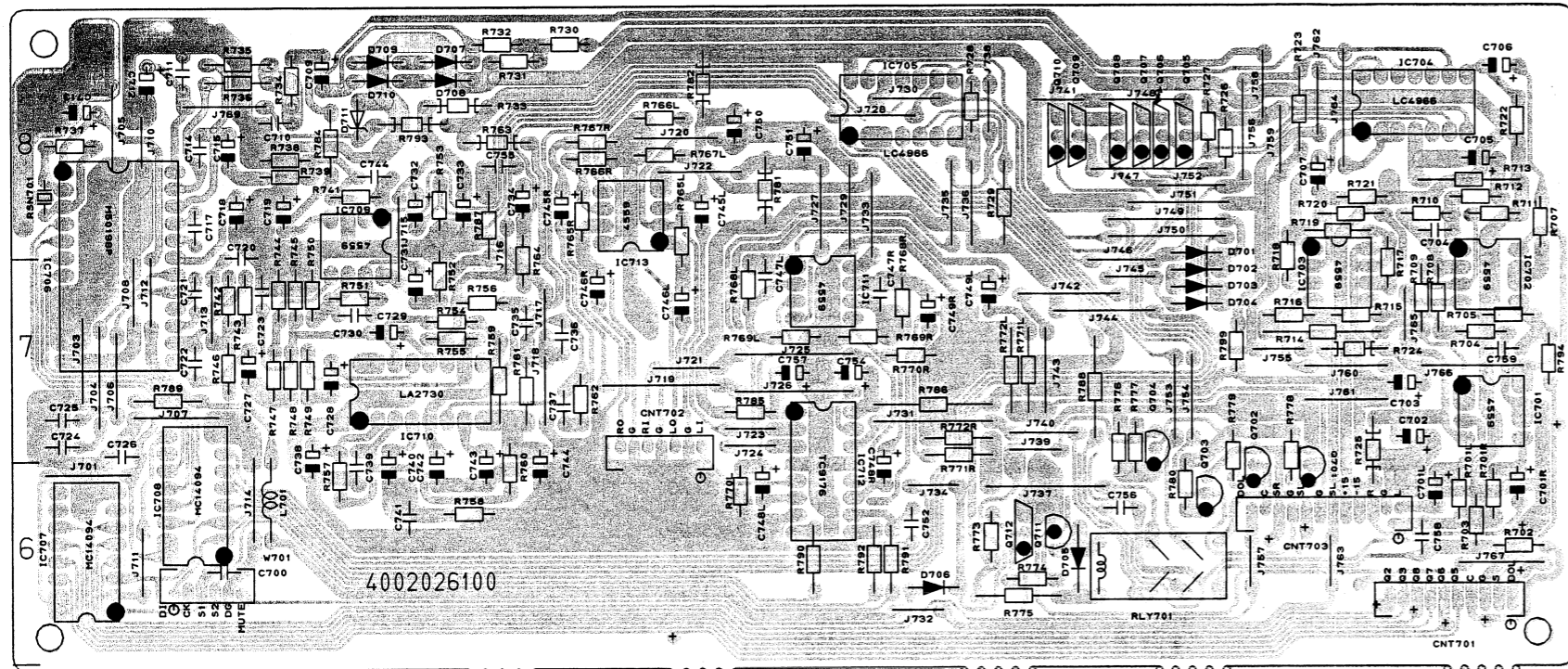

POWER PCB

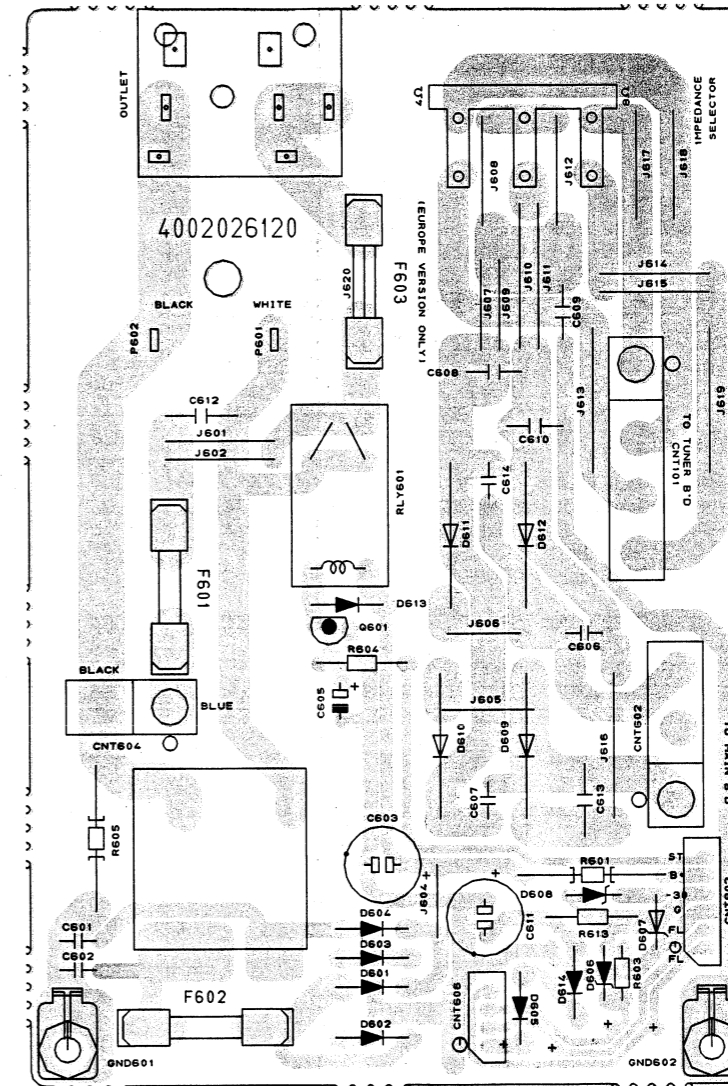

VCR2 PCB

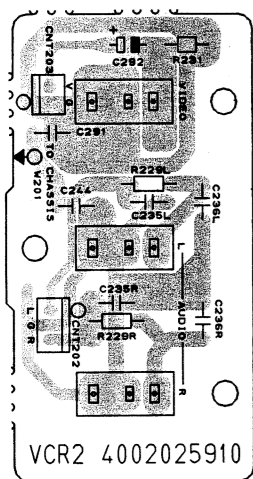

BALANCE PCB

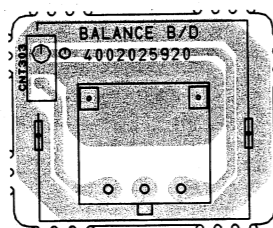

POWER SW PCB

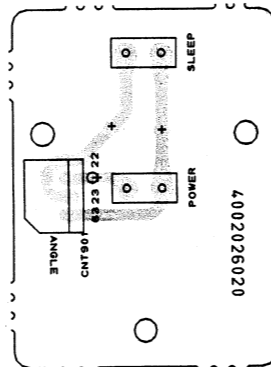

LED PCB

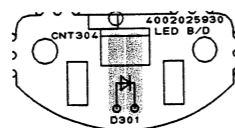

MAIN PCB ASSY

REF. NO.	PARTS NO.	DESCRIPTION
	*9A04199000	MAIN PCB ASSY
	*9A04202500	HEAT SINK, REG TR
	*9A04202600	HEAT SINK, REG TR
	9A04200700	TERMINAL, SPEAKER
	9A04202100	JACK, LGA6502-0150
	9A04202000	JACK, LGY6501-0600
	9A04201900	JACK, RCA 1P
	9A04201800	JACK, RCA 3P
	9A04201600	JACK, RCA 6P
	9A04201500	JACK, RCA 4P
	9A04201700	JACK, RCA 2P
C543,544	△ 9A04221300	C, E SG 1000UF/35V M CV
CNT202	9A04201000	CONN., 3P GIL-S-3P-S2T2-EF
CNT203	9A04200900	CONN., 2P GIL-S-2P-S2T2-EF
CNT204	9A04304200	CONNECTOR ASSY, 12P 100MM
CNT206	9A04201200	CONN., 6P GIL-S-6P-S2T2-EF
CNT404	9A04201100	CONN., 4P GIL-S-4P-S2T2-EF
CNT502	9A04200800	CONNECTOR PLUG, 3P
CNT503	9A04304400	CONNECTOR ASSY, 6P 400MM
CNT600	9A04201400	CONNECTOR, AC 1P
CNT602	9A04201300	CONNECTOR, AC 3P
CNT701	9A04304500	CONNECTOR ASSY, 10P 300MM
CNT803	9A04304600	CONNECTOR ASSY, 4P 200MM
D201	9A04202800	DIODE, IN4148M
D203,204	9A04203600	DIODE, ZENER UZ 6.2BSB
D501L/R	9A04203800	DIODE, ZENER UZ 12.0BSC
D502L/R	9A04202800	DIODE, IN4148M
D503L/R	9A04202800	DIODE, IN4148M
D504L/R	9A04202800	DIODE, IN4148M
D506	9A04203700	DIODE, ZENER UZ 15.0BSC
D507	9A04203500	DIODE, IN4002
D512	9A04202800	DIODE, IN4148M
D513	9A04202800	DIODE, IN4148M
D515	9A04202800	DIODE, IN4148M
GND501	9A04305300	PLATE, GROUND 1P
IC201	9A04199800	IC, KIA75559P (KIA4559P)
IC202	9A04199500	IC, SSM2126
IC203	9A04199600	IC, LC7821
IC204	9A04199600	IC, LC7821
IC205	9A04304700	IC, BA7625
IC206	9A04199400	IC, MC14094
IC207	9A04199800	IC, KIA75559P (KIA4559P)
IC209	△ 9A04199900	IC, GD7805
IC210	△ 9A04200000	IC, GL7915GS
IC211	△ 9A04198500	IC, GD7815
L501L/R	9A04200100	COIL INDUCTOR, 0.5MH
Q201,202	9A04221900	TR, KTA1015Y
Q203,204	9A04203400	TR, DTC114YS
Q205	9A04198400	TR, MPSA06
Q500L/R	9A04203000	TR, KTC1815Y
Q501L/R	9A04203300	TR, KTC2240BL
Q502L/R	9A04203300	TR, KTC2240BL
Q503L/R	9A04203000	TR, KTC1815Y
Q504L/R	9A04221900	TR, KTA1015Y
Q505L/R	9A04202900	TR, BKA949Y
Q506L/R	9A04203200	TR, KTC2229Y
Q508L/R	9A04199300	TR, KSD401Y
Q509L/R	9A04199200	TR, KSB546Y
Q510L/R	9A04198400	TR, MPSA06
Q511L/R	△ 9A04198600	TR, ZSC3855

Q512L/R	△ 9A04198700	TR, 2SA1491
Q513	9A04198400	TR, MPSA06
Q514,515	9A04203000	TR, KTC1815Y
Q517	9A04203000	TR, KTC1815Y
Q523	9A04221900	TR, KTA1015Y
Q524	9A04203000	TR, KTC1815Y
Q591-594	9A04203000	TR, KTC1815Y
R265,266	9A04304900	R, MF 1W 180 J
R522L/R	△ 9A04200400	R, CEMENT 5W 0.39
R523L/R	△ 9A04200400	R, CEMENT 5W 0.39
R526L/R	△ 9A04200200	R, MF 1W 10 J
R530	△ 9A04204100	R, MF 1W 22 J
R540	△ 9A04305100	R, MF 1W 2.2 J
R557	△ 9A04305200	R, MF 2W 47 J
R558	△ 9A04204300	R, MF 1W 3.3 J
R559	△ 9A04200200	R, MF 1W 10 J
RLY501	9A04202400	RELAY, OSA-SS-224DM5
RLY701	9A04202300	RELAY, RZ12

TUNER PCB ASSY

REF. NO.	PARTS NO.	DESCRIPTION
	*9A04211400	TUNER PCB ASSY
	9A04217900	FUSE CLIP, PFC5000-0202
	9A04213900	TERMINAL, SPEAKER 2P
	9A04213800	TERMINAL, PUSH 4P
	9A04213700	TERMINAL, PUSH 4P
CF1	9A04213300	FILTER, C SFE10.7MA8
CF4	9A04213200	FILTER, C SFZ450B
CF5	9A04326000	RESONATOR, BFU450C4N
CF6	9A04213600	RESONATOR, CSB456F11
CNT101	9A04201300	CONNECTOR, AC 3P
CNT204	9A04214400	CONN, GIL-12P-S2L2-EF
CNT801	9A04200800	CONNECTOR PLUG, 3P
CNT802	9A04214200	CONNECTOR PLUG, 6P
CNT803	9A04214100	CONN. PLUG, 4P (5267-04A)
CNT903	9A04214300	CONN, GIL-11P-S2L2-EF
D101-105	9A04202800	DIODE, IN4148M
D106	9A04203500	DIODE, IN4002
D107-114	△ 9A04211500	DIODE, IN5402
D115/116	9A04203500	DIODE, IN4002
F101/102	△ 9A04194700	FUSE, SB 20 3.5A 125V
F103/104	△ 9A04194600	FUSE, 51S 125V 3A (UL/C)
FE101	9A04213500	FM, FE306-A15
IC101	9A04211800	IC, LA1266
IC102	9A04211900	IC, LA3410
IC103	9A04211700	IC, LM7001
LI01	9A04212000	COIL, AM ANT
LI02	9A04212100	COIL, AM OSC
LI03	9A04212300	COIL, FM QUAD DET (A)
LI04	9A04212400	COIL, QUAD DET(B) FM TKO
LI05	9A04212500	COIL, AM IFT P-7SB
LI06/107	9A04212200	COIL, MPX 19KHZ FB-7SG
LI09-111	9A04200100	COIL INDUCTOR, 0.5MH
Q101	9A04214800	TR, KTC1923Y TAPING
Q102	9A04203300	TR, KTC2240BL
Q103	9A04214600	FET, N-CH 2SK168D
Q104-107	9A04214700	TR, DTA114YS
Q109L/R	9A04203000	TR, KTC1815Y
TC101	9A04213000	C, TRIMMER TZ03-R200FR 169
TC102	9A04212900	C, TRIMMER TZ03-T110FR 169
VD101/102	9A04211600	DIODE, VARACTOR KV1236Z

VR101	9A04216400	R, SEMI EVN-DJAA03B54
VR103	9A04216300	R, SEMI 220K
X101	9A04213400	X'TAL, 7.200MHZ

BOTTOM PCB ASSY

REF. NO.	PARTS NO.	DESCRIPTION
	*9A04220800	BOTTOM PCB ASSY
	9A04217900	FUSE CLIP, PFC5000-0202
C827/828	△ 9A04324800	C, E SG 2200UF/35V M
C830/831	△ 9A04221400	C, E SG 2200UF/35V CV
CNT206	9A04326800	CONNECTOR ASSY, 6P 260MM
CNT301	9A04327000	CONNECTOR ASSY, 10P 160MM
CNT401	9A04326700	CONNECTOR ASSY, 4P 350MM
CNT403	9A04327500	CONN., 9P GIL-S-9P-S2T2-EF
CNT703	9A04327200	CONNECTOR ASSY, 12P 120MM
CNT801	9A04326500	CONNECTOR ASSY, 7P 450MM
CNT802	9A04304400	CONNECTOR ASSY, 6P 400MM
D401	9A04202800	DIODE, IN4148M
D801/802	9A04203500	DIODE, IN4002
D803/804	9A04202800	DIODE, IN4148M
D805	9A04203700	DIODE, ZENER UZ 15.0BSC
D806/807	9A04202800	DIODE, IN4148M
D808	9A04203500	DIODE, IN4002
F801L/R	△ 9A04194800	FUSE, 51M 125V 3A (UL/C)
GND801	9A04305300	GROUND PLATE, 1P
IC402,403	9A04199800	IC, KIA75559P (KIA4559P)
IC801	△ 9A04220900	IC, HYBRID STK4122MK2
IC802	△ 9A04221000	IC, HYBRID STK4026(11)
Q401	9A04198400	TR, MPSA06
Q402L/R	9A04214900	TR, KTD1302B
Q801	9A04203000	TR, KTC1815Y
Q806	9A04203400	TR, DTC114YS
R804	△ 9A04324300	R, CF 1/4W 10 J
R820/821	△ 9A04219200	R, CF 1/4W 100 J
R824	△ 9A04221200	R, WW CE 3W 0.27 K S
R826	9A04221100	R, MF 1W 47 J
RLY401	9A04202300	RELAY, RZ12
RLY801	9A04221700	RELAY, OSA-SS-224DM3

FRONT PCB ASSY

REF. NO.	PARTS NO.	DESCRIPTION
	*9A04218000	FRONT PCB ASSY
	9A04220300	SW, SKHV10910D01
	9A04303400	SW, TACT
C914	△ 9A04218400	C, E SA 0.047UF/5.5V J
CNT302	9A04218600	CONNECTOR ASSY, 6P 120MM
CNT901	9A04326300	CONNECTOR ASSY, 3P 100MM
CNT902	9A04326400	CONNECTOR ASSY, 6P 300MM
CNT903	9A04327100	CONNECTOR ASSY, 11P 400MM
CNT904	9A04218600	CONNECTOR ASSY, 6P 120MM
D901	9A04219100	DIODE, ZENER UZ 9.1BSC
D902	9A04219000	DIODE, ZENER UZ 5.1BSC
D903-917	9A04202800	DIODE, IN4148M
FIP901	9A04218200	FL TUBE FIP 12 LM 8
IC901	9A04218100	IC, UPD75216ACW-W42
IC902	△ 9A04218300	REMOTE SENSOR, KRM-34L1
Q901	9A04218800	TR, PNP KTA817A KEC
Q902/903	9A04203000	TR, KTC1815Y
RSN901	9A04326100	RESONATOR, 4.19MHZ

VOLUME PCB ASSY

REF. NO.	PARTS NO.	DESCRIPTION
	*9A04229400	VOLUME PCB ASSY
	9A04229900	SW, PUSH
	9A04229600	VR, MOTOR 50KA*4
CNT301	9A04229800	CONNECTOR, GIL-10P-S2L2-EF
CNT302	9A04201200	CONN, 6P GIL-S-6P-S2T2-EF
CNT303	9A04201000	CONN, 3P GIL-S-3P-S2T2-EF
CNT304	9A04229700	CONNECTOR PLUG, 2P
CNT702	9A04326900	CONNECTOR ASSY, 7P 300MM
IC301	9A04229500	IC, TA7291S

TONE PCB ASSY

REF. NO.	PARTS NO.	DESCRIPTION
	*9A04228000	TONE PCB ASSY
	9A04228100	VR, RK16K12B0Z0114B
CNT403	9A04228200	CONNECTOR ASSY, 9P 200MM
IC401	9A04199800	IC, KIA75559P (KIA4559P)

HEADPHONE PCB ASSY

REF. NO.	PARTS NO.	DESCRIPTION
	*9A04228700	HEADPHONE PCB ASSY
	9A04229100	BRACKET, PCB SPK
	9A04228900	JACK, PHONE GOLD
	9A04229000	SW, SPUL19X1M071
CNT502	9A04326600	CONNECTOR ASSY, 3P 350MM
CNT503	9A04214200	CONNECTOR PLUG, 6P
R549L/R	△ 9A04229300	R, MF 2W 470 J

SURROUND PCB ASSY

REF. NO.	PARTS NO.	DESCRIPTION
	*9A04223300	SURROUND PCB ASSY
CNT701	9A04224000	CONN., 10P GIL-S-10P-S2T2EF
CNT702	9A04201000	CONN., 3P GIL-S-3P-S2T2-EF
CNT703	9A04224100	CONN., 12P GIL-S-12P-S2T2-E
CNT704	9A04201200	CONN., 6P GIL-S-6P-S2T2-EF
D701-704	9A04202800	DIODE, IN4148M
D705	9A04202800	DIODE, IN4148M
D711	9A04219000	DIODE, ZENER UZ 5.1BSC
IC701-703	9A04199800	IC, KIA75559P (KIA4559P)
IC704,705	9A04223500	IC, LC4966
IC706	9A04223600	IC, DIGI DELAY M50198P
IC707,708	9A04199400	IC, MC14094
IC709	9A04199800	IC, KIA75559P (KIA4559P)
IC710	9A04223700	IC, LA2730
IC711	9A04199800	IC, KIA75559P (KIA4559P)
IC712	9A04223400	IC, TC9176P
IC713	9A04199800	IC, KIA75559P (KIA4559P)
L701	9A04224300	COIL INDUCTOR, 4.7UH
Q701-703	9A04214900	TR, KTD1302B
Q704	9A04221900	TR, KTA1015Y
Q705	9A04214700	TR, DTA114YS
Q706/707	9A04203400	TR, DTC114YS
Q708/709	9A04214700	TR, DTA114YS
Q710	9A04203400	TR, DTC114YS
Q711	9A04198400	TR, MPSA06



Q712      9A04203400    TR, DTC114YS  
 RSN701    9A04223800    RESONATOR, CST3.27MGW

### POWER PCB ASSY

REF. NO.	PARTS NO.	DESCRIPTION
	*9A04226300	POWER PCB ASSY
	9A04217900	FUSE CLIP, PFC5000-0202
	9A04220300	SW, SKHV10910D01
	Δ *9A04227200	AC OUTLET, CCT1304-0212
SW601	Δ 9A04227300	SW, SDKGA4343B
CNT602	9A04327600	CONNECTOR, AC 3P
CNT604	9A04227000	CONNECTOR PLUG, AC S-2 2P
CNT606	9A04327300	CONNECTOR PLUG, 4P
CNT902	9A04200800	CONNECTOR PLUG, 3P
D601-604	Δ 9A04203500	DIODE, 1N4002
D605	9A04203500	DIODE, 1N4002
D606	9A04227600	DIODE, ZENER UZ 7.5BSC
D607/608	9A04203700	DIODE, ZENER UZ 15.0BSC
D609-612	Δ 9A04226400	DIODE, RECTIFIER PX6A03
D613/614	9A04203500	DIODE, 1N4002
F601	Δ 9A04194900	FUSE, 51S 125V 6.3A(UL/C)
F602	Δ 9A04327700	FUSE, SLW-BLW 125V 315MA
Q601	9A04324000	TR, MPS A06
R601	Δ 9A04324200	R, MF 2W 22 J
R605	Δ 9A04324400	R, CF 1/5W 3.3M J
RLY601	Δ 9A04327800	RELAY, OSZ-SS-112DM8
TRANS602	Δ 9A04226500	PWR(ST-BY)TRANS., RV5010R/A

### VCR 2 PCB ASSY

REF. NO.	PARTS NO.	DESCRIPTION
	*9A04210100	VCR 2 PCB ASSY
	9A04210400	JACK, RCA 1P YKB11-0868
CNT202	9A04305400	CONNECTOR ASSY, 3P 400MM
CNT203	9A04305500	CONNECTOR ASSY, 2P 500MM

### BALANCE PCB ASSY

REF. NO.	PARTS NO.	DESCRIPTION
	*9A04210600	BALANCE PCB ASSY
	*9A04210800	SHIELD FENCE, B
	9A04210700	VR, RK16KI18000114H
CNT303	9A04305600	CONNECTOR ASSY, 3P 200MM

### LED PCB ASSY

REF. NO.	PARTS NO.	DESCRIPTION
	*9A04210900	LED PCB ASSY
CNT304	9A04211100	CNT MO 5264 #28 180DL
D301	9A04305700	LED, SLR54UR3 LED

### POWER SW PCB ASSY

REF. NO.	PARTS NO.	DESCRIPTION
	*9A04220400	POWER SW PCB ASSY
CNT901	9A04327400	CONNECTOR PLUG, 3P ANGLE

**AG-V3020**

**MEMO**

MEMO

# AG-V3020

---

# TEAC®

---

<b>TEAC CORPORATION</b>	Musashino Center Bldg.,1-19-18, Nakacho, Musashino-shi, Tokyo 180, Japan	Phone:(0422)52-5081
TEAC AMERICA, INC.	7733 Telegraph Road, Montebello, California 90640	Phone:(213)726-0303
TEAC CANADA LTD.	340 Brunel Road, Mississauga, Ontario L4Z 2C2, Canada	Phone:416-890-8008
TEAC UK LIMITED	5 Marlin House, Marlin Meadow, The Croxley Centre, Watford, Herts. WD1 8YA, U.K.	Phone:0923-819631
TEAC DEUTSCHLAND GmbH	Bahnstrasse 12, 6200 Wiesbaden-Erbenheim, Germany	Phone:0611-71580
TEAC FRANCE S.A.	17, Rue Alexis-de-Tocqueville, CE 005 92182 Antony Cedex, France	Phone:(1)42.37.01.02
TEAC BELGIUM NV/SA	143C Woluwelaan, 1831 Machelen-Diegem, Belgium	Phone:(02)725-6555
TEAC NEDERLAND BV	Perkinsbaan 11, 3439 ND Nieuwegein, Nederland	Phone:03-402-30229
TEAC AUSTRALIA PTY., LTD. A.C.N. 005 408 462	106 Bay Street, Port Melbourne, Victoria 3207, Australia	Phone:(03)646-1733
TEAC ITALIANA S.p.A.	Via C. Cantù 5, Cinisello Balsamo, Milano, Italy	Phone:02-66010500

# TEAC®

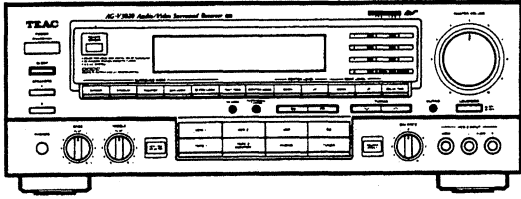

## SERVICE MANUAL

# AG-V3020

Audio/Video Surround Receiver

## SUPPLEMENT

Please use this Supplement together with the original AG-V3020 Service Manual (Parts No.: 5704064400).

### NOTES ON PARTS LIST

- Except for parts information on pages 3 and 4 in the Supplement, the original manual's all the parts information are applicable to four versions (US, C, E, and GE).
- Parts marked with \* require longer delivery time.
- The parts with no reference number or no parts number in the exploded views are not supplied.
- As regards the resistors and capacitors, refer to the circuit diagrams contained in this manual.
- $\Delta$  Parts marked with this sign are safety critical components. They must be replaced with identical components - refer to the appropriate parts list and ensure exact replacement.
- Parts of [ ] mark can be used only with the version designated.  
[J]: JAPAN [US]: U. S. A. [C]: CANADA [GE]: GENERAL EXPORT [E]: EUROPE [UK]: U. K. [A]: AUSTRALIA

## 2. ADJUSTMENTS AND CHECKS

The original manual's all "Adjustments and Checks" information about General Export models is also applicable to Europe models.

## 4. IC BLOCK DIAGRAMS

FRONT END: FE 407-G60 (FOR EUROPE. VERSION ONLY)

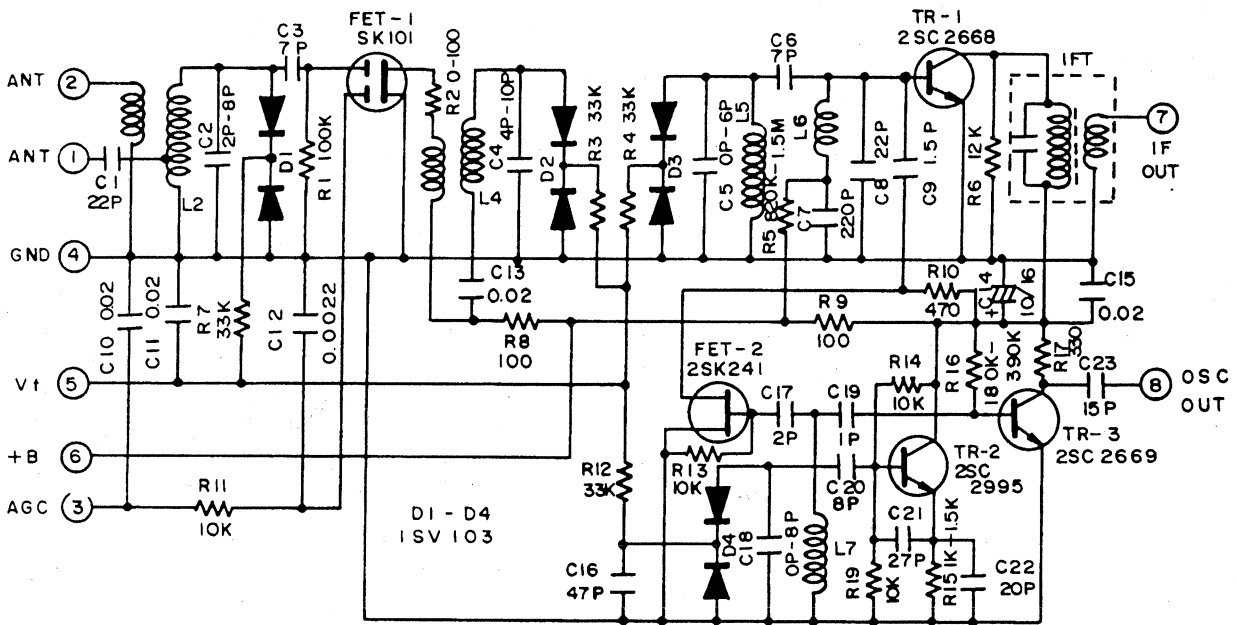

## 5. EXPLODED VIEW AND PARTS LIST

U.S.A. and Canada (US, C)

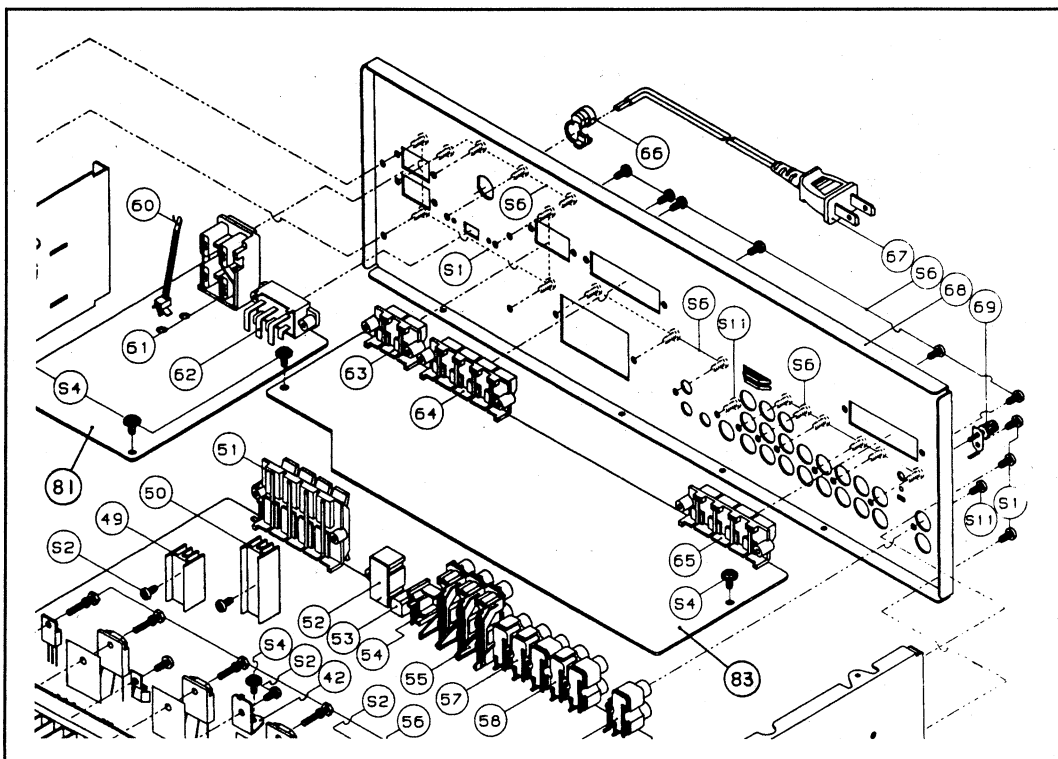

Europe (E)

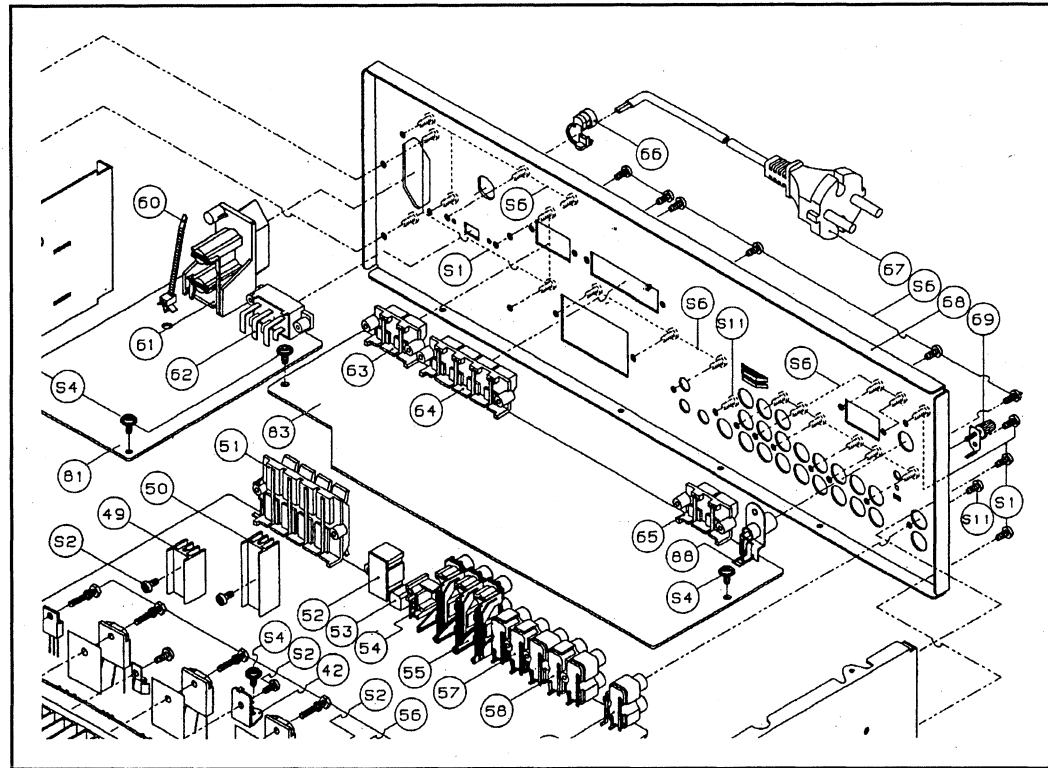

REF. NO.	PARTS NO.	DESCRIPTION	REMARKS
44	*9A04192000	COVER, BOTTOM [US,C]	
	*9A04541500	COVER, BOTTOM [E,GE]	
61	△ 9A04227200	AC OUTLET [US,C,GE]	
	△ 9A04544800	AC OUTLET [E]	
62	△ 9A04227300	SW, SLIDE (SW601) [US,C,GE]	
	△ 9A04544900	SW, SLIDE (SW601) [E]	
65	9A04213700	TERMINAL, PUSH 4P [US,C,GE]	
	9A04540700	TERMINAL, ANTENNA [E]	
66	△ 9A04194300	CORD, STOPPER [US,C]	
	△ 9A04545500	CORD, STOPPER [E,GE]	
67	△ 9A04194200	AC CORD [US,C]	
	△ 9A04544200	AC CORD [E,GE]	
68	*9A04194000	CHASSIS, BACK [US,C]	
	*9A04541400	CHASSIS, BACK [GE]	
	*9A04548200	CHASSIS, BACK [E]	
70	△ 9A04195200	POWER TRANS. (TRANS601) [US,C]	
	△ 9A04542100	POWER TRANS. 230V/50Hz (TRANS601)[E]	
	△ 9A04546000	POWER TRANS. 120V/230V (TRANS601)[GE]	
81	*9A04226300	POWER PCB ASSY [US,C]	
	*9A04226320	POWER PCB ASSY [E]	
	*9A04226350	POWER PCB ASSY [GE]	
83	*9A04211400	TUNER PCB ASSY [US,C]	
	*9A04211420	TUNER PCB ASSY [E]	
	*9A04211450	TUNER PCB ASSY [GE]	
84	*9A04540900	SELECTOR PCB ASSY [GE]	
85	9A04546600	SW, SLIDE [GE]	
86	9A04544900	SW, SLIDE [GE]	
87	9A04544600	ADAPTER, AC PLUG [GE]	INCLUDED ACCESSORY
88	9A04540800	JACK, ANTENNA [E]	

General Export (GE)

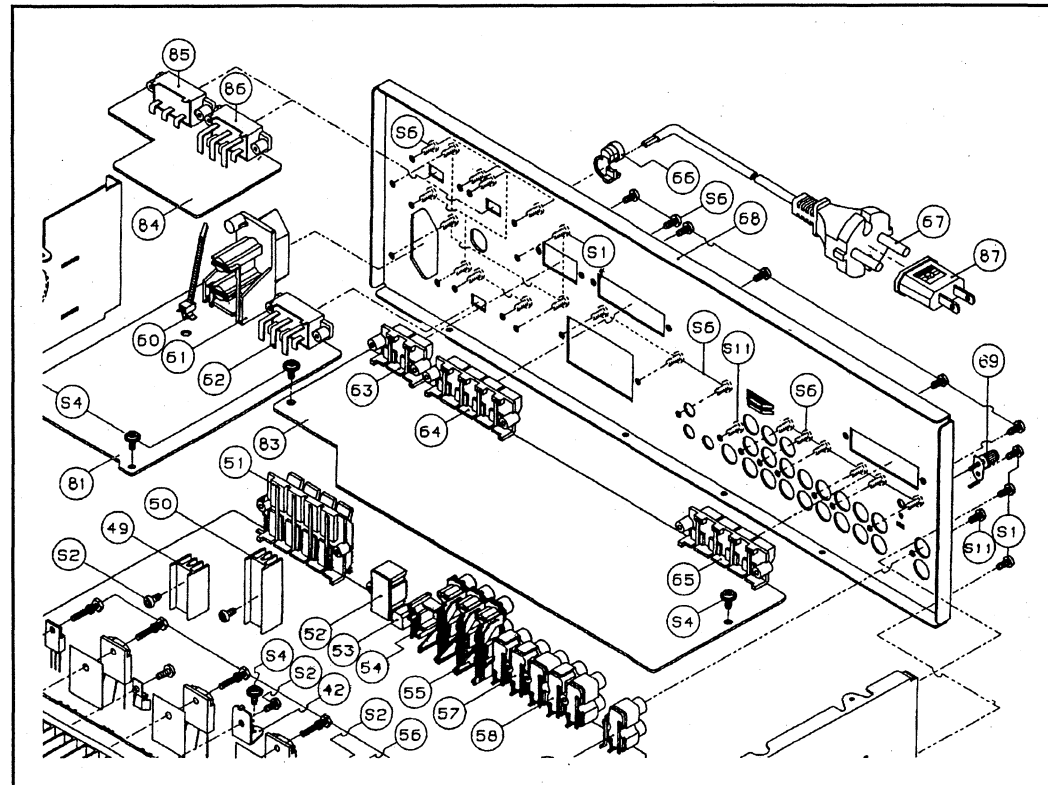

REF. NO.	PARTS NO.	DESCRIPTION	REMARKS
	*9A04324100	ANTENNA, AM LOOP	
	*9A04326200	ANTENNA, FM 300 OHMS [US,C]	
	*9A04544300	ANTENNA, FM [E]	
	*9A04546300	ANTENNA, FM [GE]	
	*9A04191500	REMOCON UNIT, UR-404	
	9A04328200	BATTERY (AA, R06, SUM-3)	
	*9A04151100	OWNER'S MANUAL, ENG./FRE.	
	*9A04446700	OWNER'S MANUAL, GERMAN [E]	
	*9A04544700	MATCHING TRANS., [E]	
87	*9A04544600	ADAPTER, AC PLUG [GE]	

## 6. PC BOARDS AND PARTS LIST

### TUNER PCB ASSY

REF. NO.	PARTS NO.	DESCRIPTION
83	*9A04211400	TUNER PCB ASSY [US,C]
83	*9A04211420	TUNER PCB ASSY [E]
83	*9A04211450	TUNER PCB ASSY [GE]
	9A04217900	FUSE CLIP, PFC5000-0202
63	9A04213900	TERMINAL, SPEAKER 2P
64	9A04213800	TERMINAL, SPEAKER 4P
65	9A04213700	TERM., ANTENNA 4P [US,C,GE]
65	9A04540700	TERMINAL, ANTENNA[E]
88	9A04540800	JACK, ANTENNA [E]
CF1,2	9A04213300	FILTER, C SFE10.7MA8 [US,C]
CF1,2	9A04544000	FILTER, 10.7MS3G [E,GE]
CF4	9A04213200	FILTER, C SFZ450B
CF5	9A04326000	RESONATOR, BFU450C4N
CF6	9A04213600	RESONATOR, CSB456F11
CNT101	9A04201300	CONNECTOR, AC 3P
CNT102	9A04201300	CONNECTOR, AC 3P
CNT204	9A04214400	CNT, GIL-12P-S2L2-EF
CNT801	9A04200800	CONNECTOR PLUG, 3P
CNT802	9A04214200	CONNECTOR PLUG, 6P
CNT803	9A04214100	CON.PLUG, 4P(5267-04A)
CNT903	9A04214300	CNT, GIL-11P-S2L2-EF
DI01-105	9A04202800	DIODE, IN4148M
DI06	9A04203500	DIODE, IN4002
DI07-114	9A04211500	DIODE, IN5402
DI15/116	9A04203500	DIODE, IN4002
FI01/102	9A04194700	FUSE, SB 20 3.5A 125V [US,C]
FI01/102	9A04545300	FUSE, T3.15/250V [E,GE]
FI03/104	9A04194600	FUSE, 51S 125V 3A [US,C]
FI03/104	9A04545300	FUSE, T3.15/250V [E,GE]
FE101	9A04213500	FM, FE306-A15 [US,C,GE]
FE101	9A04544100	FM, FE407-G60 FRONT END [E]
IC101	9A04211800	IC, LA1266
IC102	9A04211900	IC, LA3410
IC103	9A04211700	IC, LM7001
LI01	9A04212000	COIL, AM ANT
LI02	9A04212100	COIL, AM OSC
LI03	9A04212300	COIL, FM QUAD DET (A)
LI04	9A04212400	COIL, QUAD DET(B) FM
LI05	9A04212500	COIL, AM IFT P-7SB
LI06/107	9A04212200	COIL, MPX 19KHZ FB-7SG
LI08	9A04542000	INDUCTOR, 20.8MH [E]
LI09-111	9A04200100	COIL INDUCTOR, 0.5MH
Q101	9A04214800	TR, KTC1923Y
Q102	9A04203300	TR, KTC2240BL
Q103	9A04214600	FET, N-CH 2SK168D
Q104-107	9A04214700	TR, DTA114YS
Q109L/R	9A04203000	TR, KTC1815Y
TC101	9A04213000	C, TRIMMER TZ03-R200FR 169
TC102	9A04212900	C, TRIMMER TZ03-T110FR 169
VDI01/102	9A04211600	DIODE, VARACTOR KV1236Z
VR101,102	9A04216400	VR, SEMI 50K EVN-DJAA03B54
VR102	9A04542900	VR, SEMI 100K [E]
VR103	9A04216300	VR, SEMI 220K
XI01	9A04213400	X'TAL, 7.200MHZ

### POWER PCB ASSY

REF. NO.	PARTS NO.	DESCRIPTION
81	*9A04226300	POWER PCB ASSY [US,C]
81	*9A04226320	POWER PCB ASSY [E]
81	*9A04226350	POWER PCB ASSY [GE]
	9A04217900	FUSE CLIP, PFC5000-0202
19	9A04220300	SW, SKHVI0910D01
61	△*9A04227200	AC OUTLET [US,C,GE]
61	△*9A04544800	AC OUTLET [E]
62	△ 9A04227300	SW, SLIDE (SW601) [US,C,GE]
62	△ 9A04544900	SW, SLIDE (SW601)[E]
CNT602	9A04327600	CONNECTOR, AC 3P
CNT602	9A04195100	CNT, KST 0316LV UL#18 [E]
CNT604	9A04227000	CONNECTOR PLUG, AC S-2 2P
CNT604	9A04546400	ASSEMBLY 2P 180MM [GE]
CNT605	9A04544400	ASSEMBLY 3P 160MM [GE]
CNT606	9A04327300	CONNECTOR PLUG, 4P
CNT902	9A04200800	CONNECTOR PLUG, 3P
D601-604	△ 9A04203500	DIODE, IN4002
D605	9A04203500	DIODE, IN4002
D606	9A04227600	DIODE, ZENER UZ 7.5BSC
D607/608	9A04203700	D., ZENER UZ 15.0BSC[US,C,E]
D609-612	△ 9A04226400	DIODE, RECTIFIER PX6A03
D613	9A04203500	DIODE, IN4002 [E,GE]
D613/614	9A04203500	DIODE, IN4002 [US,C]
F601	△ 9A04194900	FUSE, 51S 125V 6.3A [US,C]
F601	△ 9A04545100	FUSE, T.LAG 6.3A/250V[GE]
F601	△ 9A04545300	FUSE, T3.15/250V [E]
F602	△ 9A04327700	FUSE, 125V 315MA [US,C]
F602	△ 9A04545000	FUSE, T.LAG 315MA/250V[E,GE]
F603	△ 9A04545200	FUSE, TIME LAG 2.5A/250V[E]
Q601	9A04198400	TR, MPSA06 [E,GE]
Q601	9A04324000	TR, MPS A06 [US,C]
R601	△ 9A04324200	R, MF 2W 22 J
R605	△ 9A04324400	R, CF 1/5W 3.3M J
RLY601	△ 9A04327800	RELAY, OSZ-SS-112DM8[US,C,E]
TRANS602	△ 9A04226500	TRANS., RV5010R/A [US,C]
TRANS602	△ 9A04542200	TRANS., 230V/50HZ [E]
TRANS602	△ 9A04546100	TRANS., 120V/230V [GE]

### SELECTOR PCB ASSY [GE ONLY]

REF. NO.	PARTS NO.	DESCRIPTION
84	*9A04540900	SELECTOR PCB ASSY
	9A04217900	FUSE CLIP, PFC5000-0202
85	9A04546600	SW, SLIDE
86	9A04544900	SW, SLIDE
CNT604	9A04227000	CONN. PLUG, AC S-2 2P
CNT605	9A04201300	CONNECTOR, AC 3P
CNT607	9A04546500	WAFER, AC 5P
F604	9A04545300	FUSE, T3.15/250V

# AG-V3020

# TEAC®

TEAC CORPORATION Musashino Center Bldg., 1-19-18, Nakacho, Musashino-shi, Tokyo 180, Japan			Phone: (0422)52-5081
TEAC AMERICA, INC.	7733 Telegraph Road, Montebello, California 90640		Phone: (213)726-0303
TEAC CANADA LTD.	340 Brunel Road, Mississauga, Ontario L4Z 2C2, Canada		Phone: 416-890-8008
TEAC UK LIMITED	5 Marlin House, Marlin Meadow, The Croxley Centre, Watford, Herts. WD1 8YA, U.K.		Phone: 0923-819631
TEAC DEUTSCHLAND GmbH	Bahnstrasse 12, 65205 Wiesbaden-Erbenheim, Germany		Phone: 0611-71580
TEAC FRANCE S.A.	17, Rue Alexis-de-Tocqueville, CE 005 92182 Antony Cedex, France		Phone: (1)42.37.01.02
TEAC BELGIUM NV/SA	143C Woluwelaan, 1831 Machelen-Diegem, Belgium		Phone: (02)725-6555
TEAC NEDERLAND BV	Perkinsbaan 11, 3439 ND Nieuwegein, Nederland		Phone: 03-402-30229
TEAC AUSTRALIA PTY., LTD. A.C.N. 005 408 462	106 Bay Street, Port Melbourne, Victoria 3207, Australia		Phone: (03)646-1733
TEAC ITALIANA S.p.A.	Via C. Cantù 5, Cinisello Balsamo, Milano, Italy		Phone: 02-66010500





**TEAC** SCHEMATIC DIAGRAM **AG-V3020** WIRING DIAGRAM

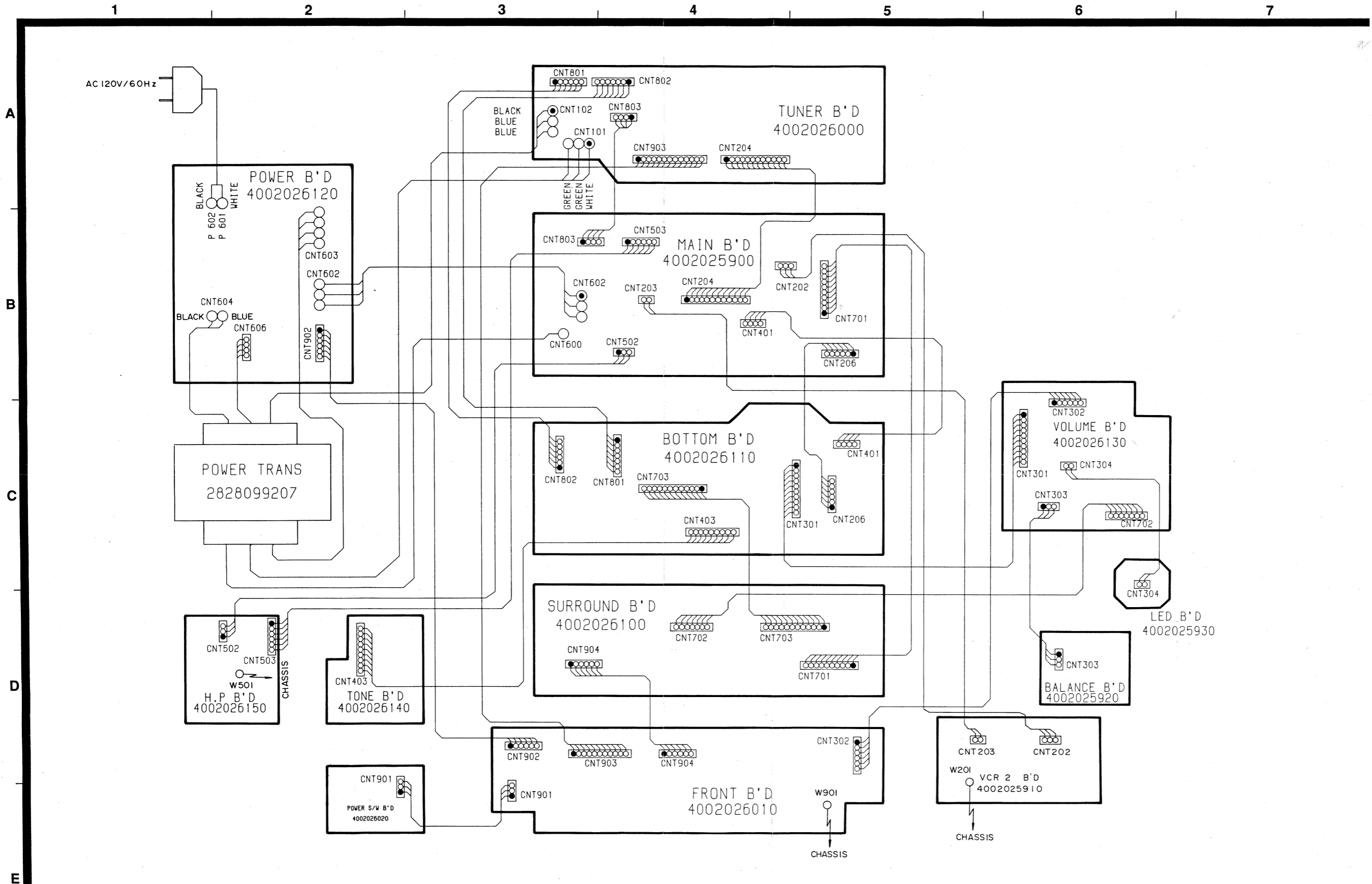

**AG-V3020**  
**Audio/Video Surround Receiver**



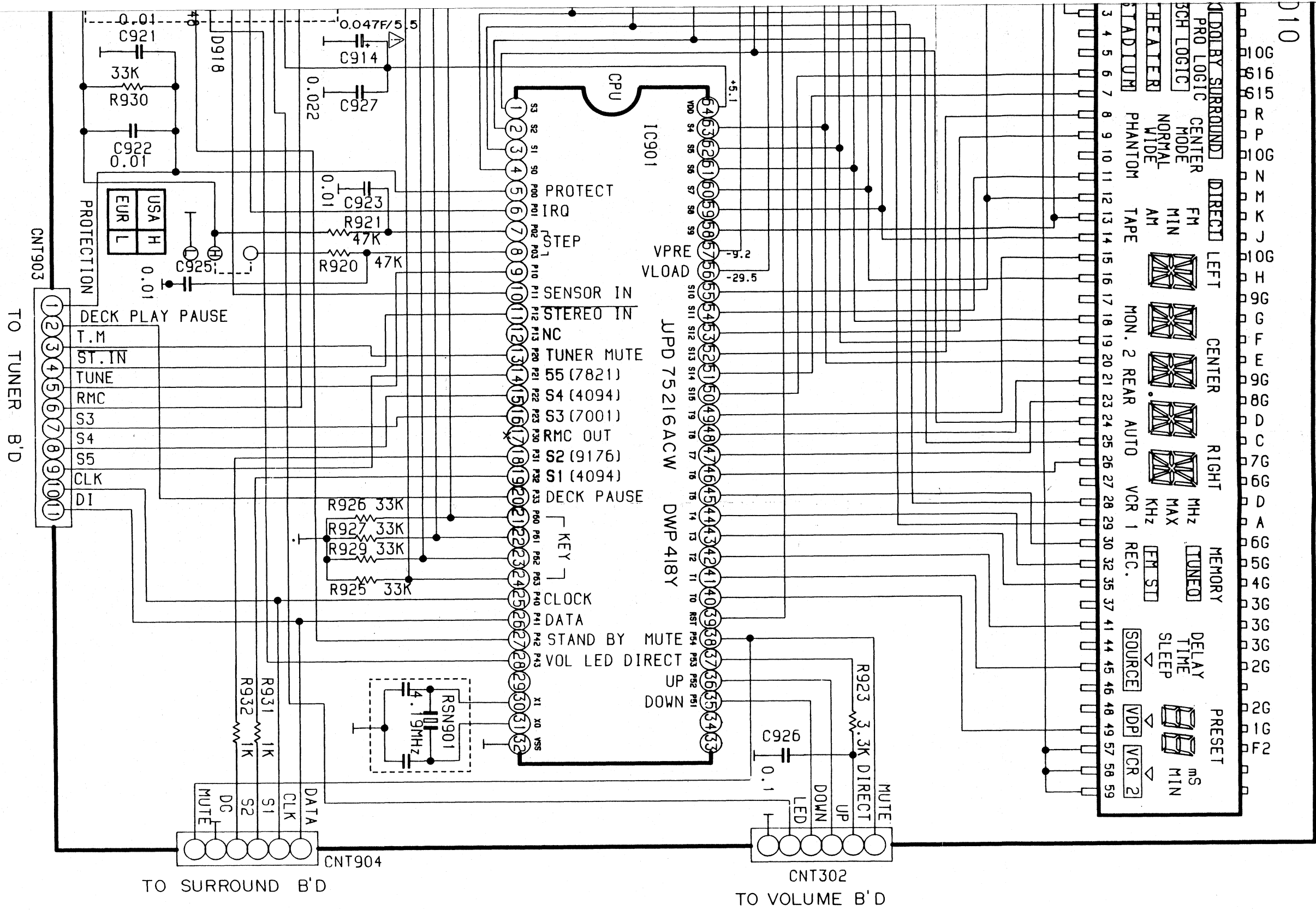

# AG-V3020

Audio/Video Surround Receiver

1st Issue, March, 1993

TEAC SCHEMATIC DIAGRAM AG-V3020 SURROUND SECTION

SURROUND B'D 4002026120

TO VOLUME B'D  
 1 2 3 4 5 6  
 CNT702

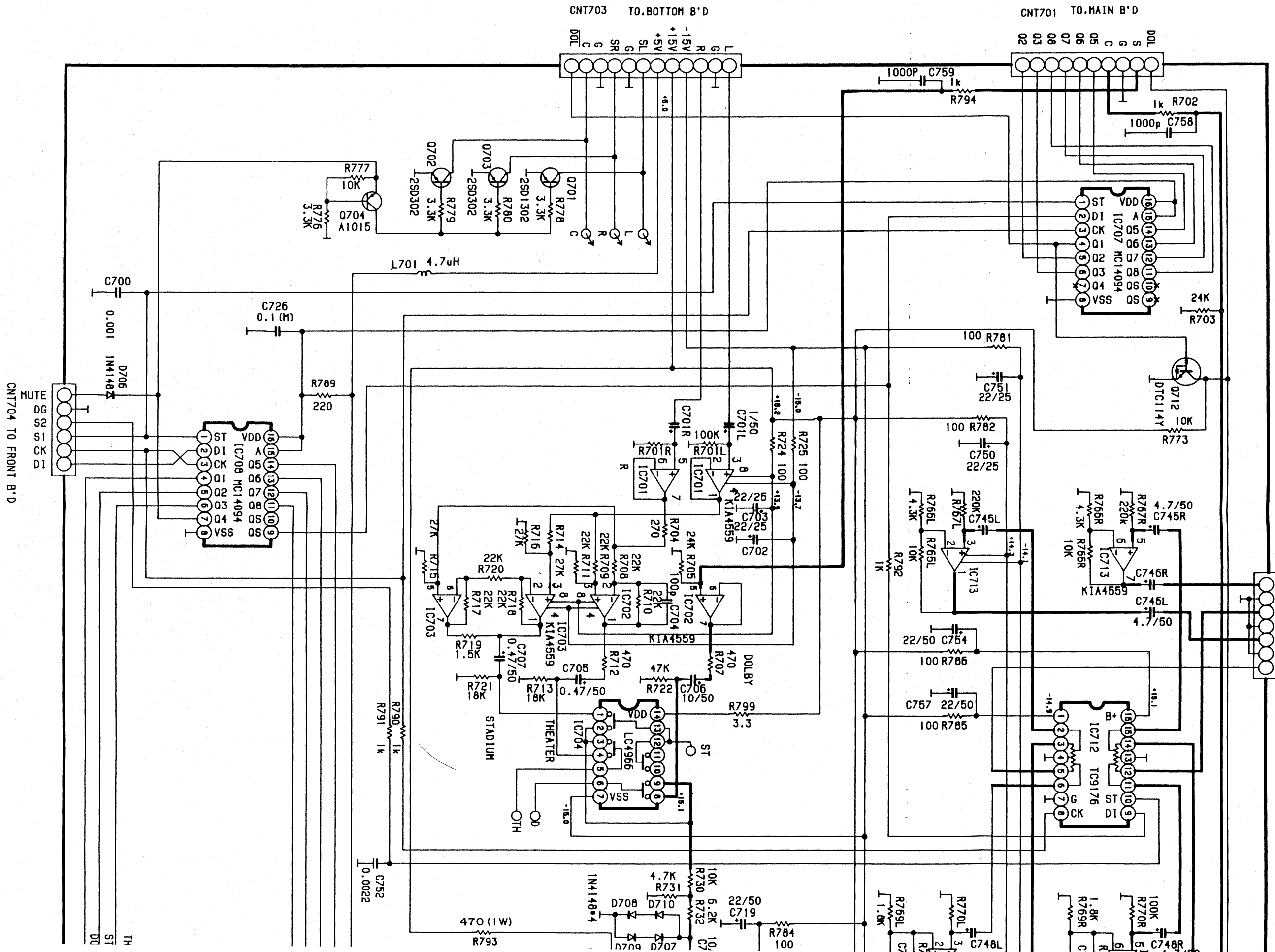

INSTRUCTIONS FOR SERVICE PERSONNEL.  
 BEFORE RETURNING APPLIANCE TO THE CUSTOMER, MAKE LEAKAGE-CURRENT OR RESISTANCE MEASUREMENTS TO DETERMINE THAT EXPOSED PARTS ARE ACCEPTABLY INSULATED FROM THE SUPPLY CIRCUIT.

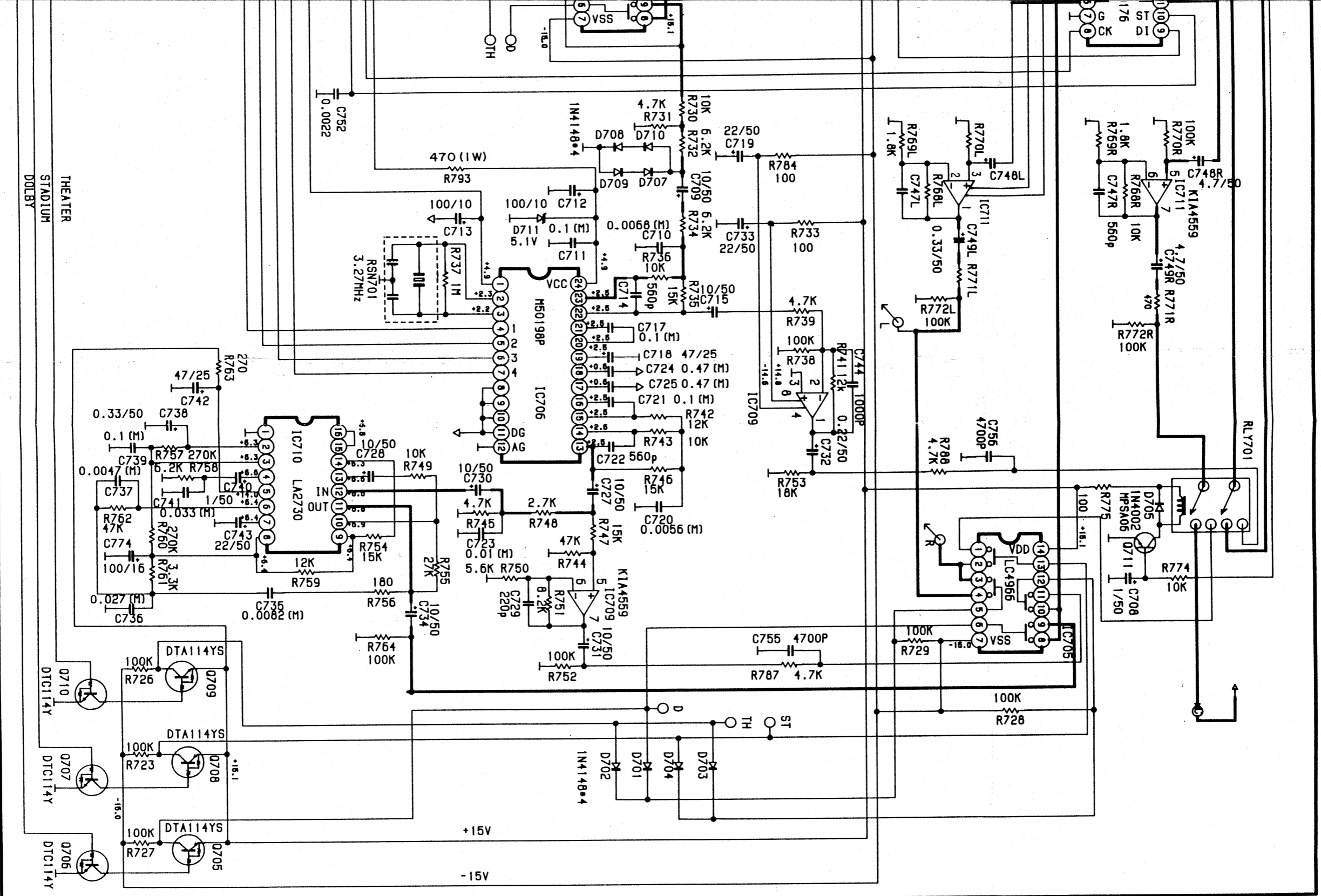

6  
7  
8  
9  
10  
11

# AG-V3020

Audio/Video Surround Receiver

1st Issue: March, 1993

TEAC SCHEMATIC DIAGRAM AG-V3020 TUNER SECTION

1 2 3 4 5 6

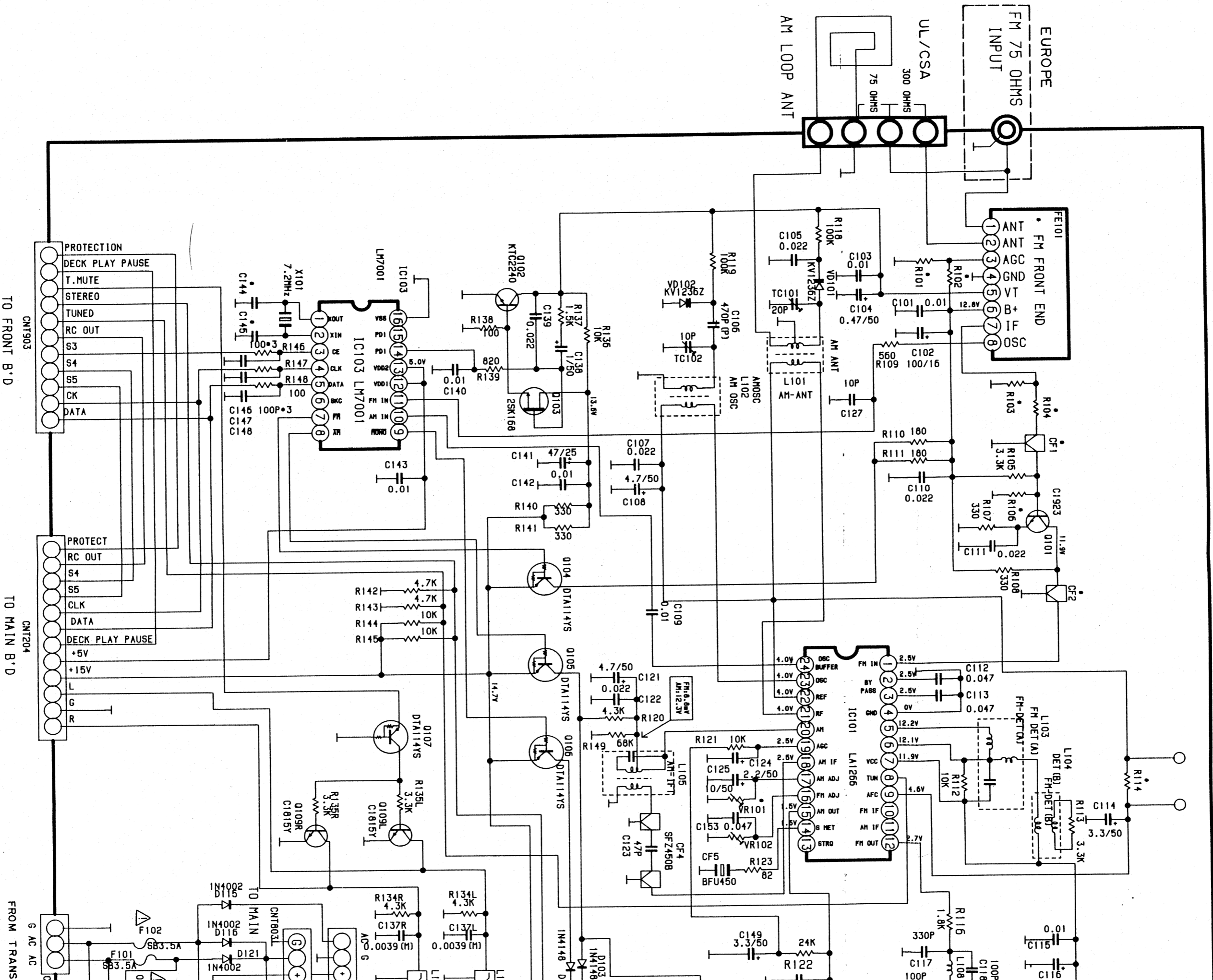

INSTRUCTIONS FOR SERVICE PERSONNEL.  
BEFORE RETURNING APPLIANCE TO THE CUSTOMER, MAKE LEAKAGE-CURRENT OR RESISTANCE MEASUREMENTS TO DETERMINE THAT EXPOSED PARTS ARE ACCEPTABLY INSULATED FROM THE SUPPLY CIRCUIT.

▲ Parts marked with this sign are safety critical components. They must always be replaced with identical components - refer to the TEAC part list and ensure exact replacement.

TO FRONT B'D  
CNT903

TO MAIN B'D  
CNT204

FROM TRANS  
G AC AC

TUNER B'D 4002026000

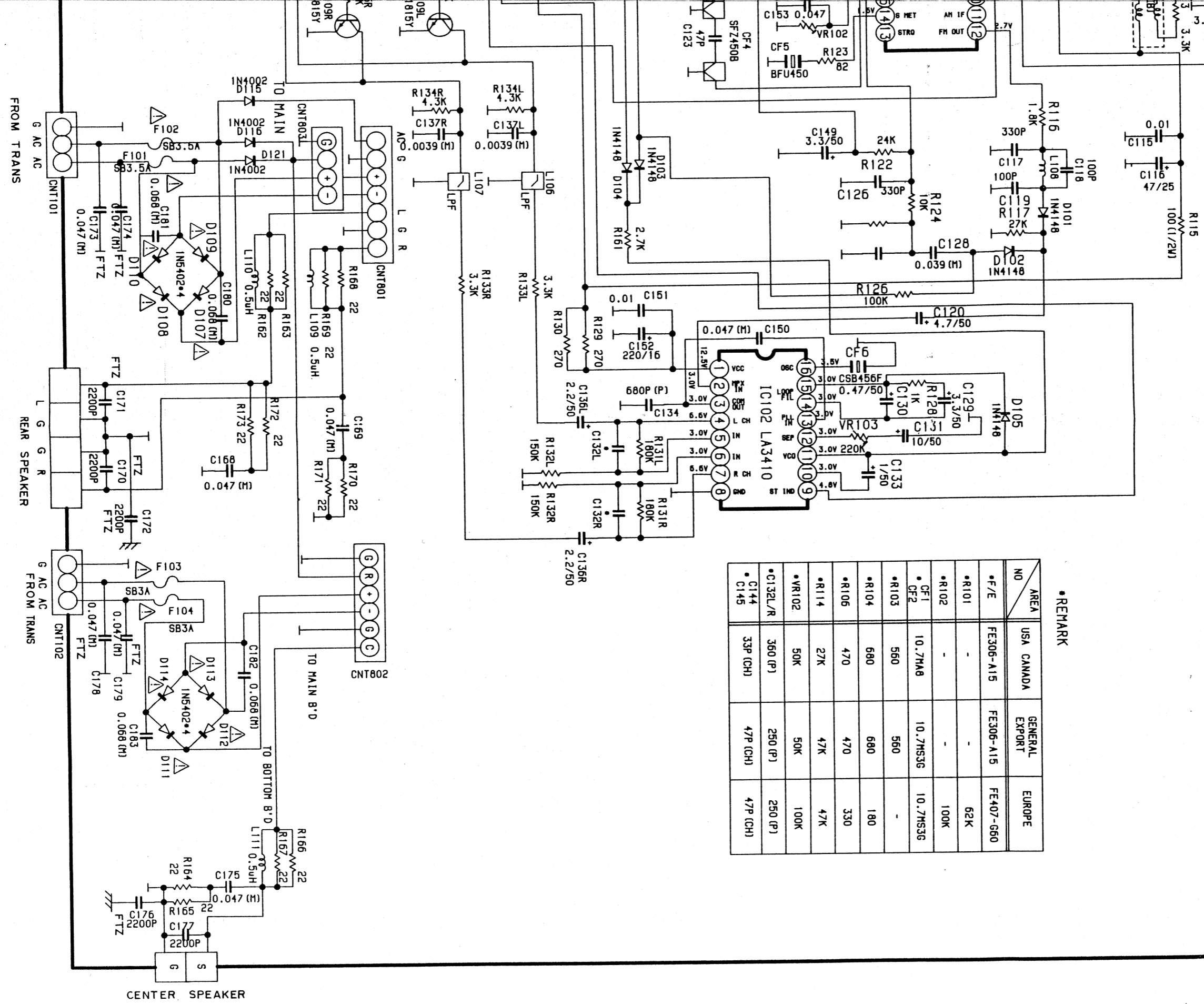

\*REMARK

AREA	USA	CANADA	GENERAL EXPORT	EUROPE
NO				
*F/E	FE306-A15	FE306-A15	FE407-G60	
*R101	-	-	62K	
*R102	-	-	100K	
*CF1	10.7MA8	10.7MS3G	10.7MS3G	
*CF2				
*R103	560	560	-	
*R104	680	680	180	
*R106	470	470	330	
*R114	27K	47K	47K	
*VR102	50K	50K	100K	
*C132L/R	360 (P)	250 (P)	250 (P)	
*C144				
*C145	33P (CH)	47P (CH)	47P (CH)	

**AG-V3020**  
Audio/Video Surround Receiver





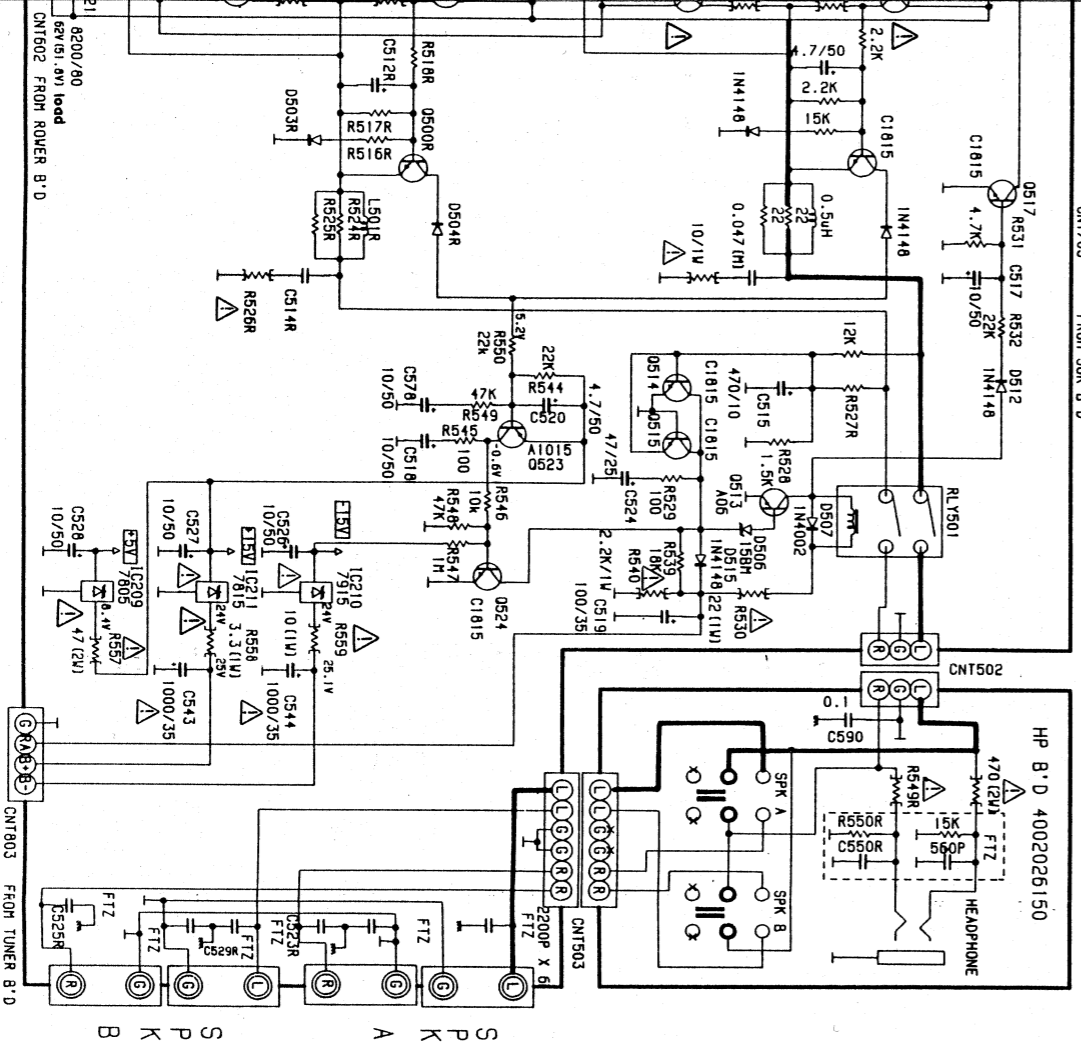
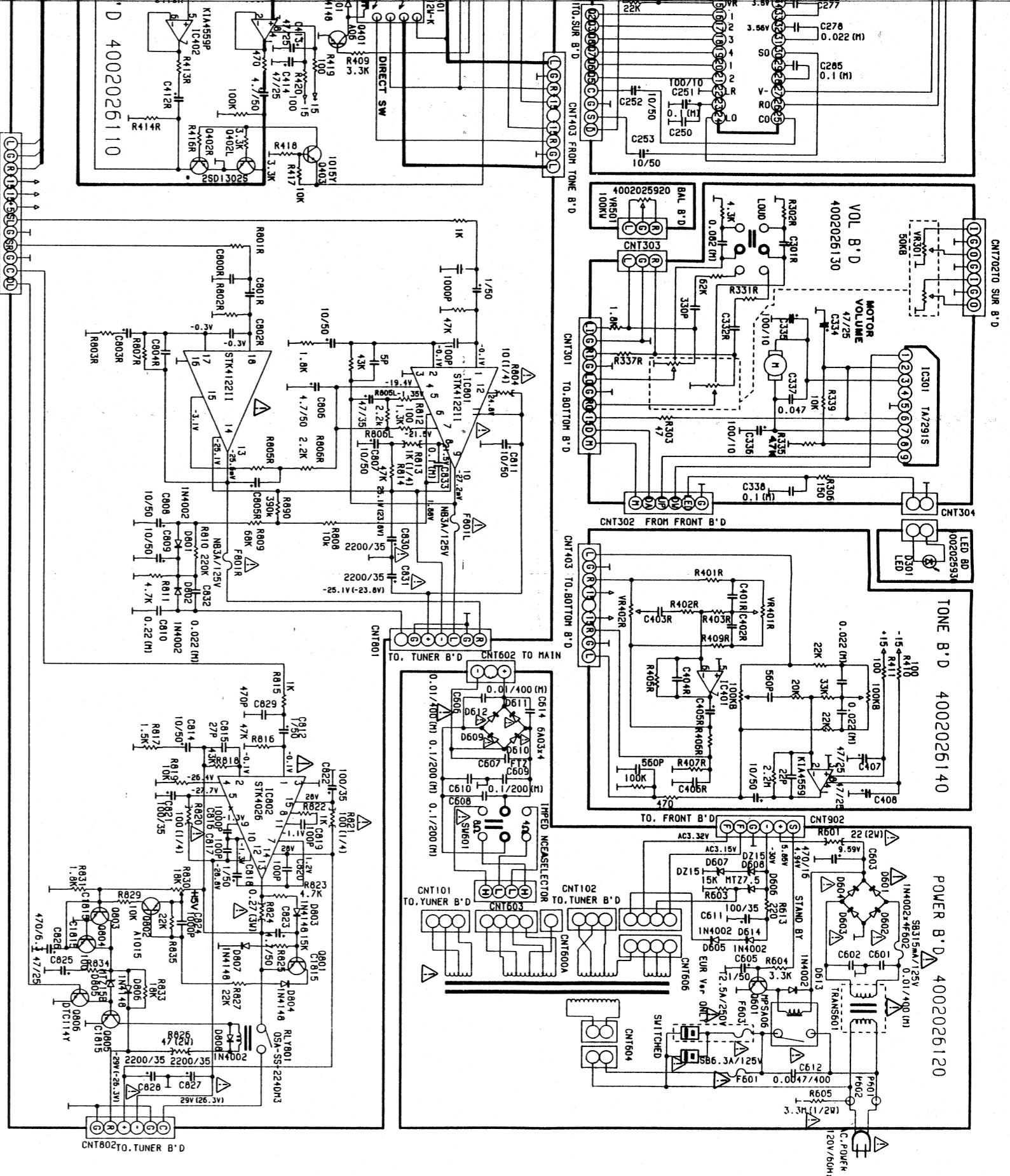

- Notes:
1. Resistance value are indicated ohms unless otherwise specified (K=1,000 M=1,000,000)
  2. Capacitance value are shown in microfarads unless otherwise noted (P=micro-micro farade)

# AG-V3020

Audio/Video Surround Receiver

**TEAC** SCHEMATIC DIAGRAM **AG-V3020** TUNER SECTION

1 2 3 4 5 6

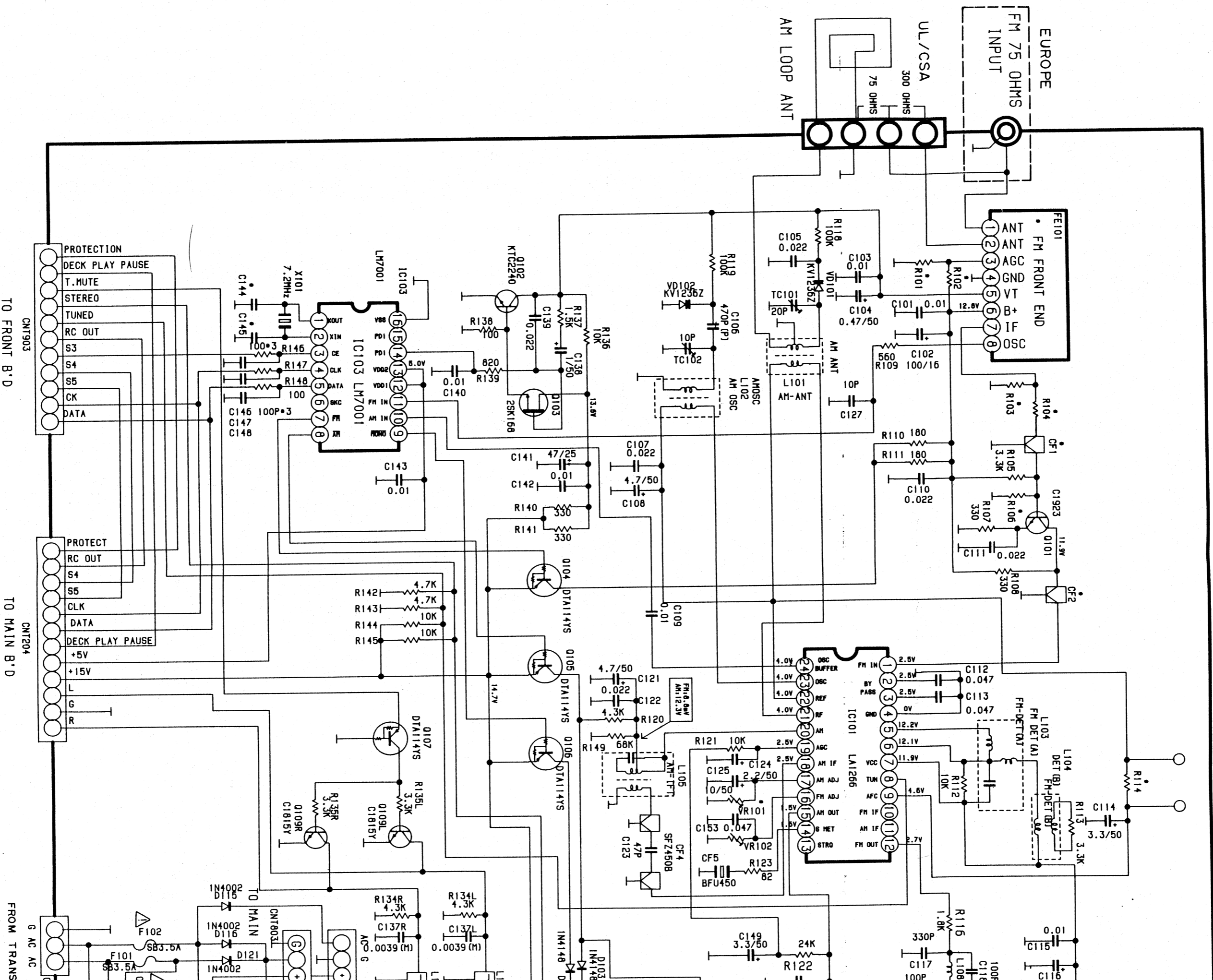

INSTRUCTIONS FOR SERVICE PERSONNEL.  
BEFORE RETURNING APPLIANCE TO THE CUSTOMER, MAKE LEAKAGE-CURRENT OR RESISTANCE MEASUREMENTS TO DETERMINE THAT EXPOSED PARTS ARE ACCEPTABLY INSULATED FROM THE SUPPLY CIRCUIT.

▲ Parts marked with this sign are safety critical components. They must always be replaced with identical components - refer to the TEAC part list and ensure exact replacement.



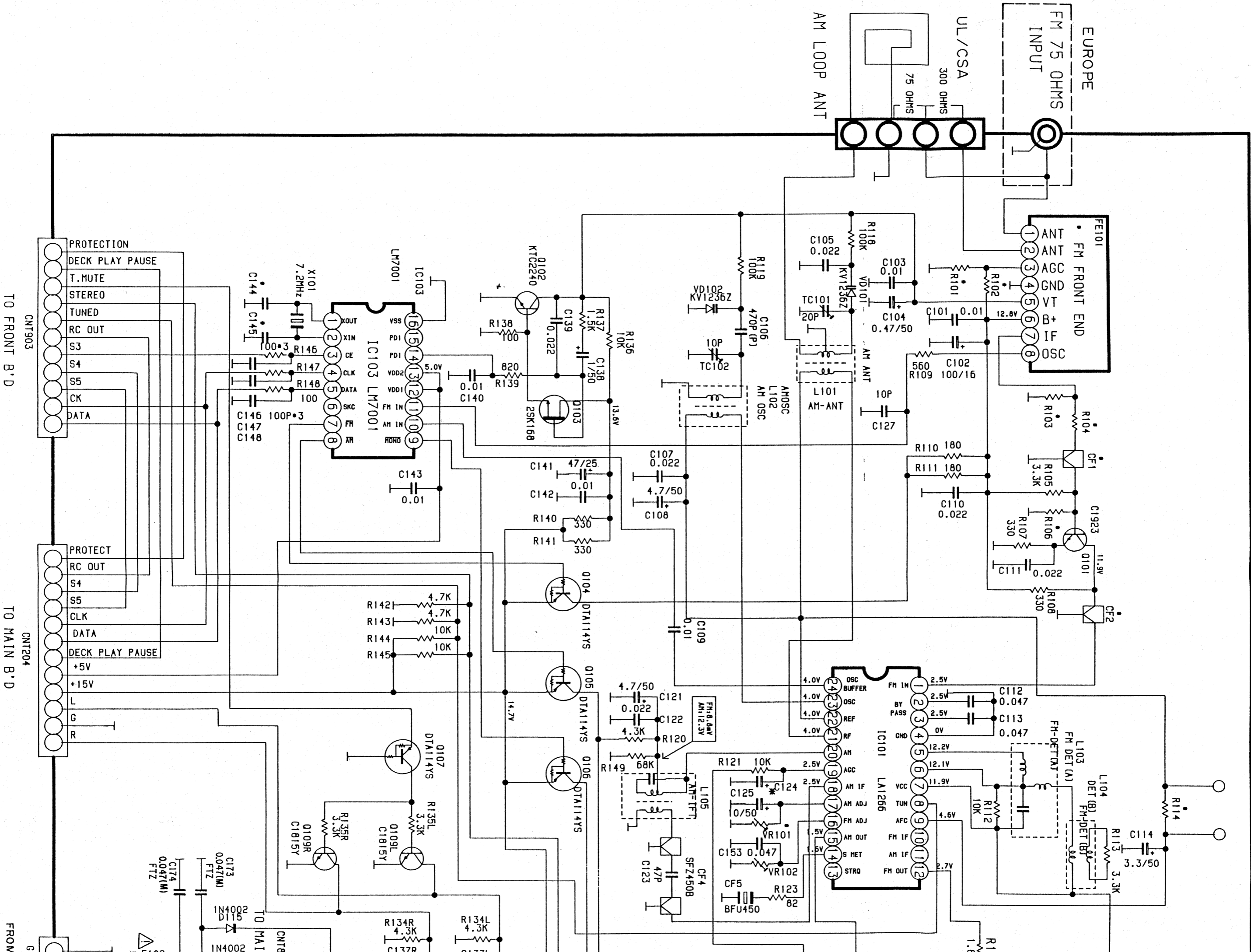

# TUNER B'D 4002026000

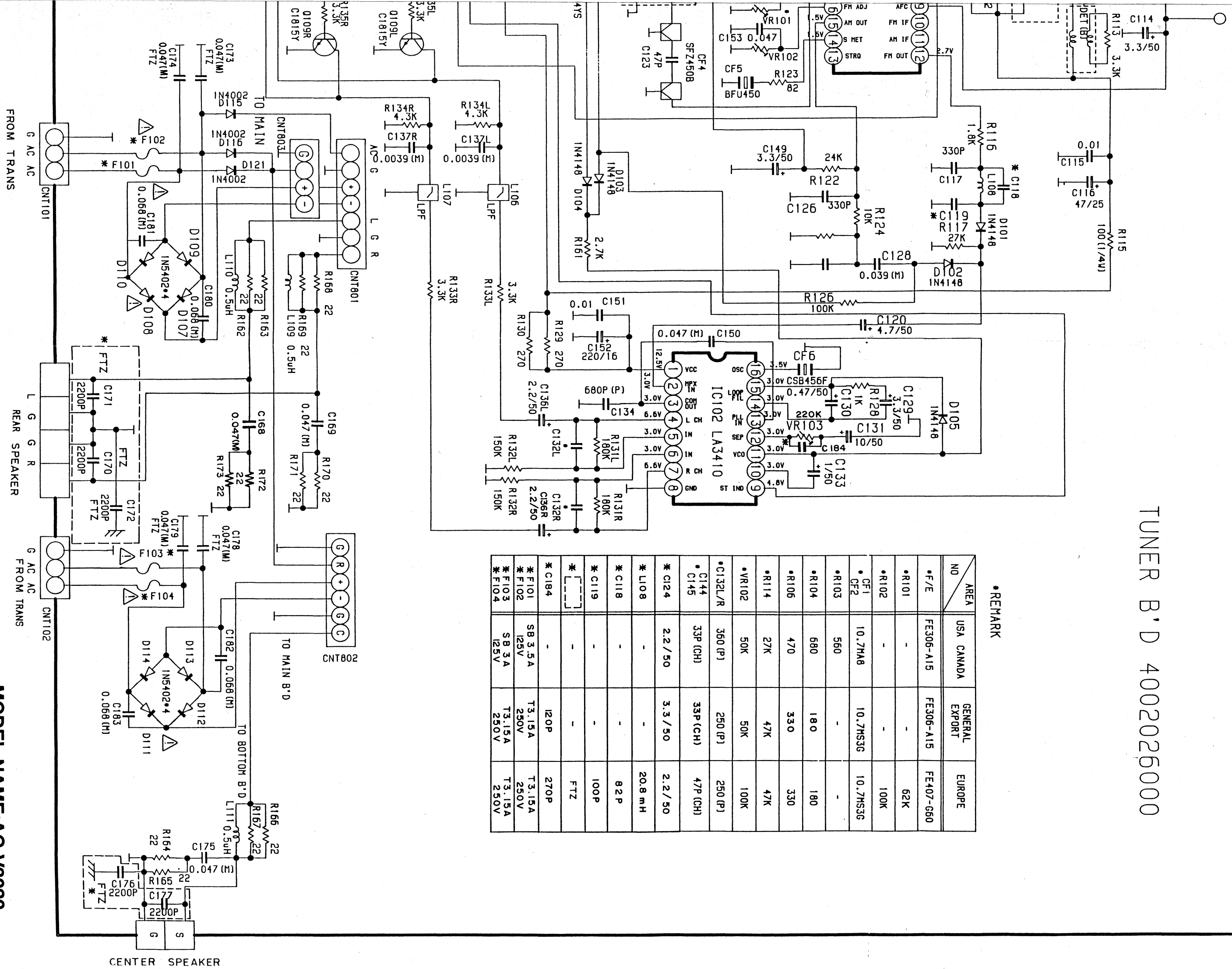

\*REMARK

NO	AREA	USA CANADA	GENERAL EXPORT	EUROPE
*F/E	FE306-A15	FE306-A15	FE407-660	
*R101	-	-	62K	
*R102	-	-	100K	
*CF1	10.7MA8	10.7MS3G	10.7MS3G	
*CF2	-	-	-	
*R103	560	-	-	
*R104	680	180	180	
*R106	470	330	330	
*R114	27K	47K	47K	
*VR102	50K	50K	100K	
*C132L/R	360 (P)	250 (P)	250 (P)	
*C144	33P (CH)	33P (CH)	47P (CH)	
*C145	-	-	-	
*C124	2.2/50	3.3/50	47P (CH)	
*L108	-	-	20.8 mH	
*C118	-	-	82P	
*C119	-	-	100P	
*C184	-	120P	270P	
*F101	SB 3.5A	T3.15A	T3.15A	
*F102	125V	250V	250V	
*F103	SB 3A	T3.15A	T3.15A	
*F104	125V	250V	250V	

MODEL NAME:AG-V3020



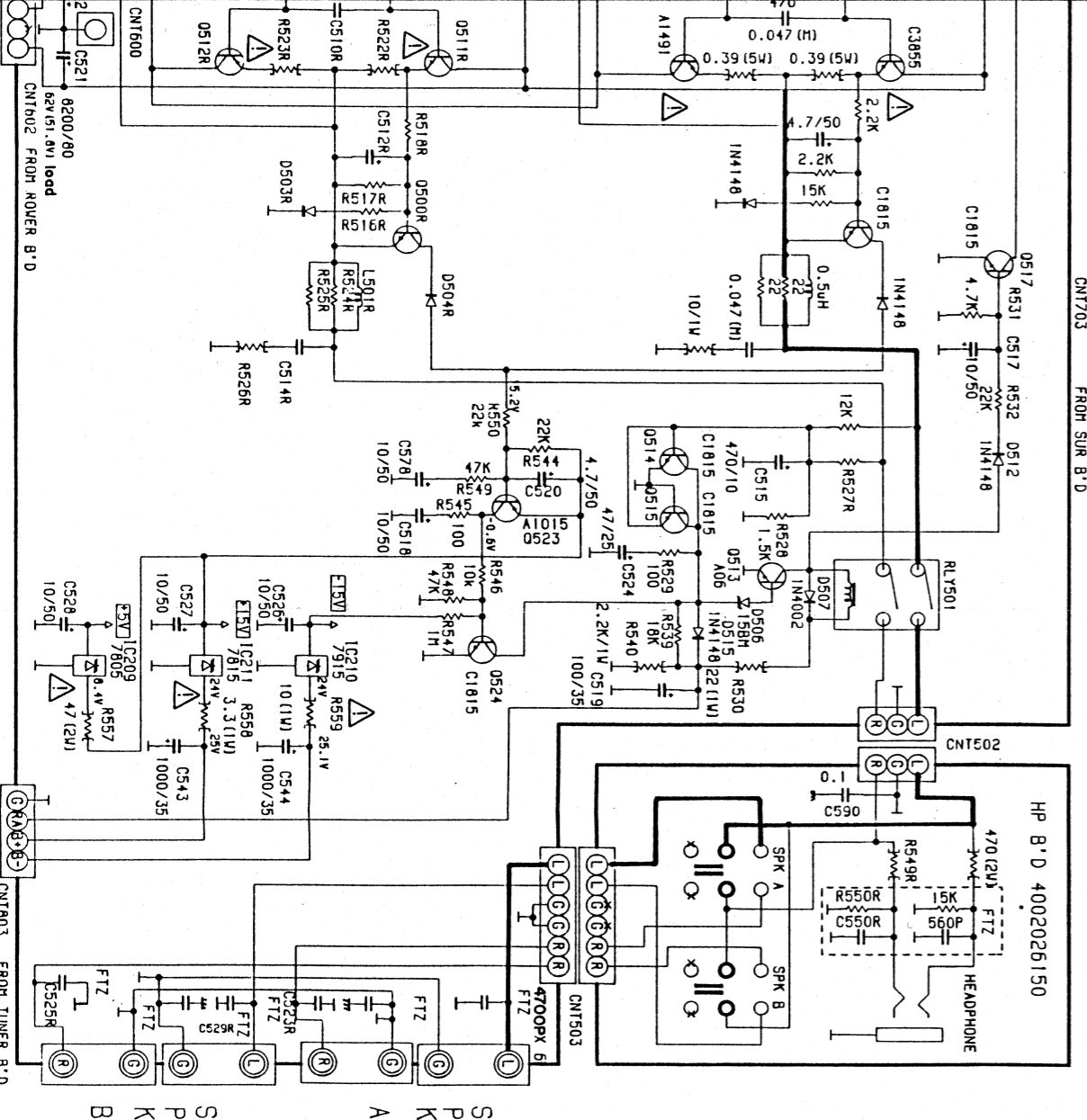
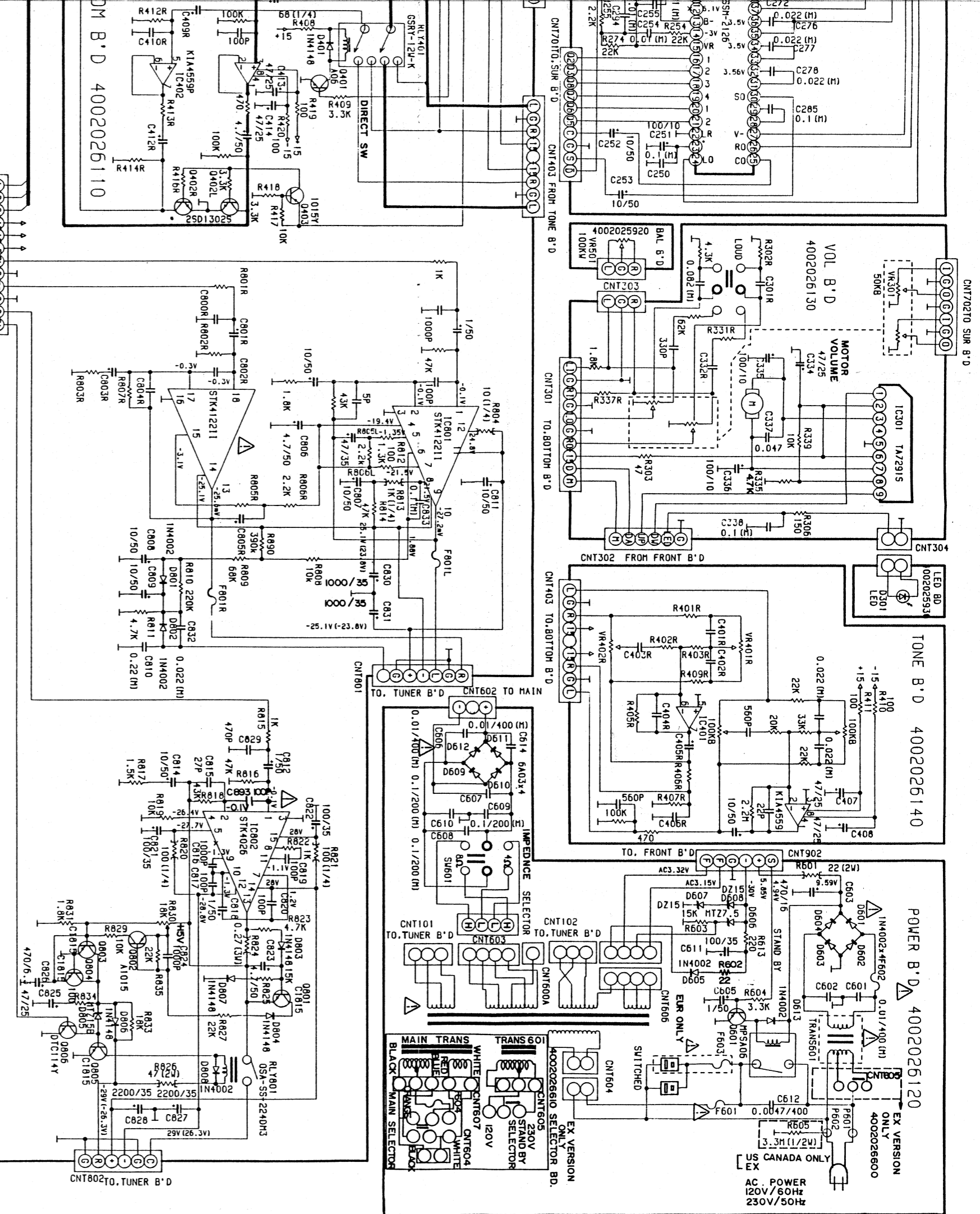

**Notes:**

1. Resistance value are indicated ohms unless otherwise specified (K=1,000 M=1,000,000)
2. Capacitance value are shown in microfarads unless otherwise noted (P=micro-micro farade)

**CAUTION**  
Safely precaution to be followed during servicing

- 1) Since these parts marked with  $\Delta$  are critical parts for safety, use the one designated on the part list.
- 2) Before returning the receiver to the customer make appropriate leakage current or resistance measurements to determine that exposed parts are properly insulated from the supply circuit.

	EUROPE	EXTERNAL
F601	US/CANADA	T3.15A/250V
F602	S8315mA/125V	T315mA/250V
F603	JUMPER	X
F604	X	T3.15A/250V
F801/R	NB3A/125V	F3.15A/250V

**MODEL NAME:AG-V3020**





THEATER  
STADIUM  
DOLBY

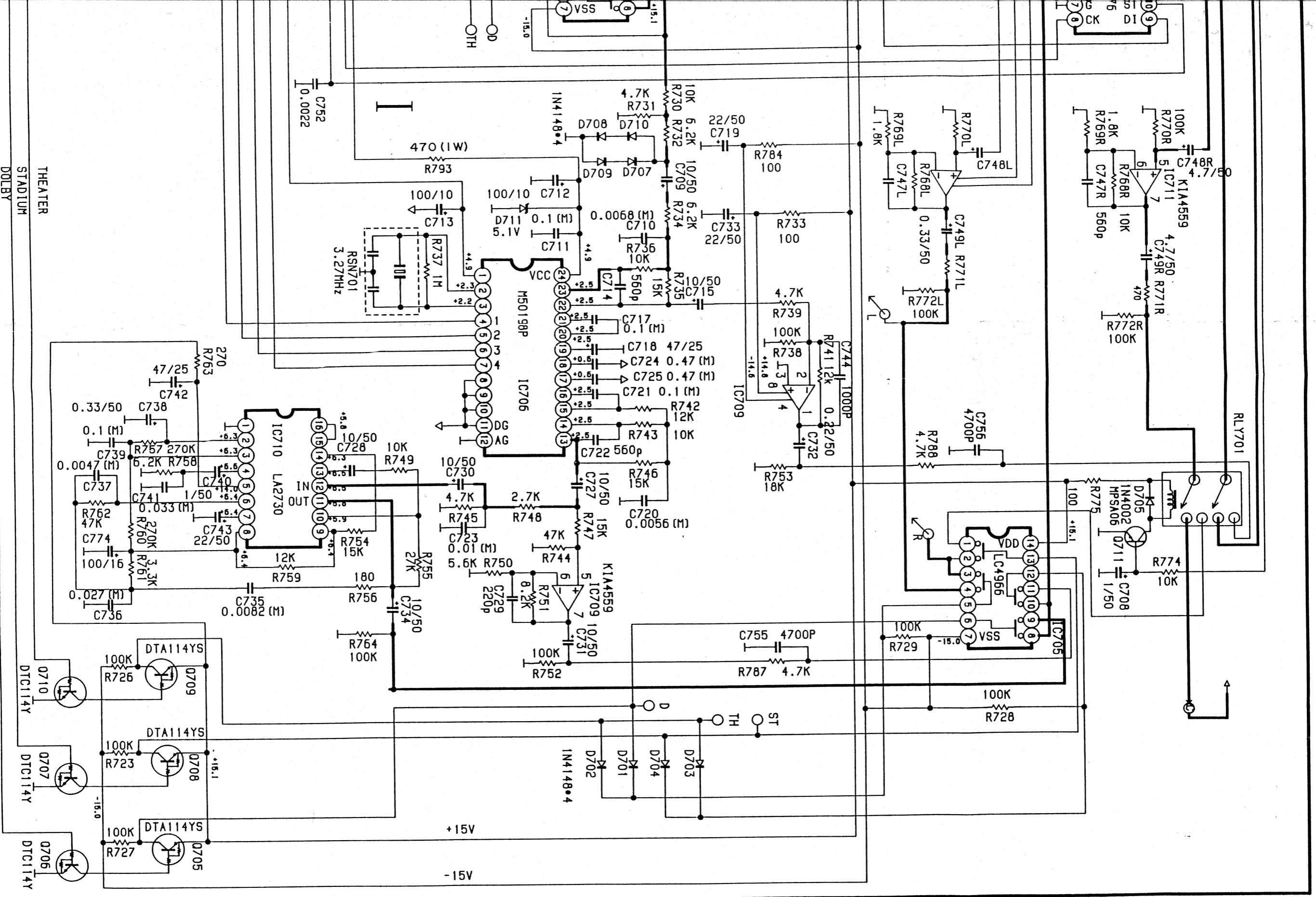

MODEL NAME:AG-V3020



