

TEAC®

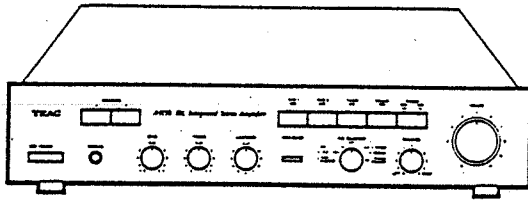

SERVICE MANUAL

A-X55_{MINI}

DC Integrated Stereo Amplifier

NOTES

1. In this manual, 0 dB is referenced to 1V.
2. Δ Parts marked with this sign are safety critical components. They must always be replaced with identical components - refer to the appropriate parts list and ensure exact replacements.
3. PC boards shown are viewed from foil side.

1 SPECIFICATIONS

Type DC Integrated Stereo Amplifier

Rated Output Power

(Both Channels, 8 ohms)

60W + 60W (1kHz, 0.03% T.H.D.)

55W + 55W (20Hz~20kHz, 0.05% T.H.D.)

Total Harmonic Distortion

0.05% (20Hz~20kHz, at 55W + 55W Output Power)

Output Bandwidth

IHF, -3dB, 10Hz~50kHz

Frequency Response

TUNER, CD/AUX, TAPE 1, 2, to SP out 5Hz, 40kHz +0, -3dB

PHONO to REC OUT, 20Hz~20kHz±0.5dB (RIAA)

Input Sensitivity

PHONO MC 0.24uV/100 ohms

PHONO MM 2.7mV/47k ohms

TUNER, CD/AUX, TAPE 1, 2, 150mV/47k ohms

Rated Output Voltage/Impedance

TAPE REC 1, 2, 150mV/47k ohms

Signal-to-Noise Ratio

(IHF A Network, short circuit)

PHONO MC 65dB

PHONO MM 75dB

TUNER, CD/AUX, TAPE 1, 2, 94dB

Tone Control

Bass ±12dB, 100Hz

Treble ±12dB, 10kHz

High Filter 10kHz, -6dB

Power Requirements

100/120/220/240 V AC 50/60 Hz, 240W (General Export Model)

220V AC 50Hz, 220W (Europe Model)

240V AC 50Hz, 240W (U.K./AUS. Model)

Dimensions (W x H x D)

435 x 80 x 295mm (17 $\frac{1}{8}$ " x 3 $\frac{1}{8}$ " x 11 $\frac{5}{8}$ ")

Weight 7.6kg (16.72 lbs) net

- Improvements may result in specification or feature changes without notice.

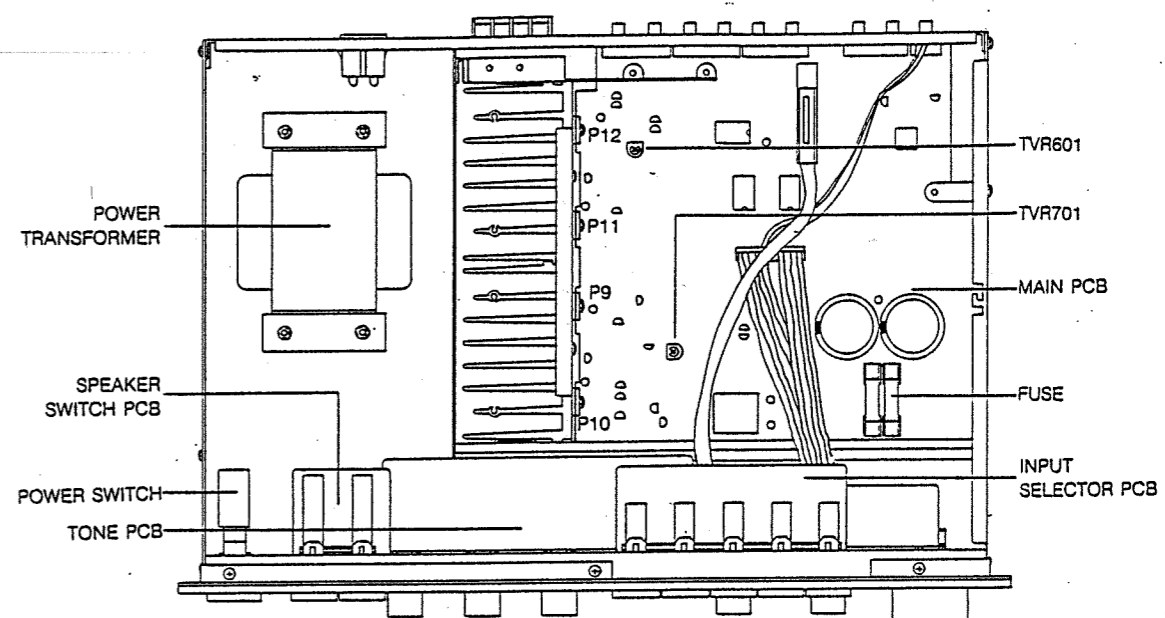

2 ADJUSTMENT LOCATION

1-1 DC BALANCE CHECK

1. Connect the DC voltmeter to SPEAKERS A terminal.
2. Depress POWER switch to ON.
3. Confirm the DC voltmeter indication within 0 V ± 20mV.

1-2 IDLING CURRENT CHECK

1. Connect the DC voltmeter between P9 to P10 and P11 to P12.
2. Confirm the DC voltmeter indication within 15mV when POWER is ON after 10 seconds.
3. If the DC voltmeter indicates over 25mV adjust the TVR601 for LEFT channel or adjust the TVR701 for RIGHT channel on the MAIN PCB.
4. After the above procedures, allow 10 minutes for the amplifier to warm up completely.

1-3 REALY OPERATION CHECK

1. Apply 1kHz/150mV (-16.5dB) to the CD/AUX terminal.
2. Adjust the VOLUME control so that output voltage is 10V at the SPEAKER terminal.
3. Shortcircuit the SPEAKER terminals between + and - so that the relay RY1 break immediately.

3 VOLTAGE CONVERSION

(FOR GENERAL EXPORT MODELS ONLY)

AC VOLTAGE SELECTION

This unit operates on 110 volts or 220 volts AC. Before connecting the power cord to your AC outlet, make sure that the setting position of this switch matches your line voltage. If not, it must be set to your voltage in accordance with the following direction.

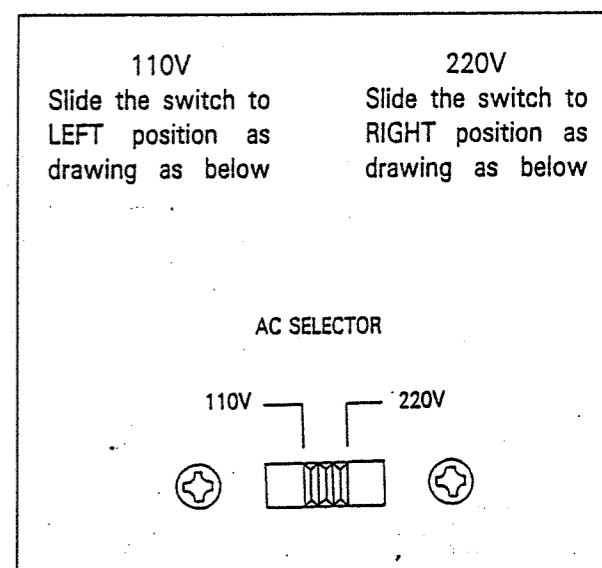

4 BLOCK DIAGRAM

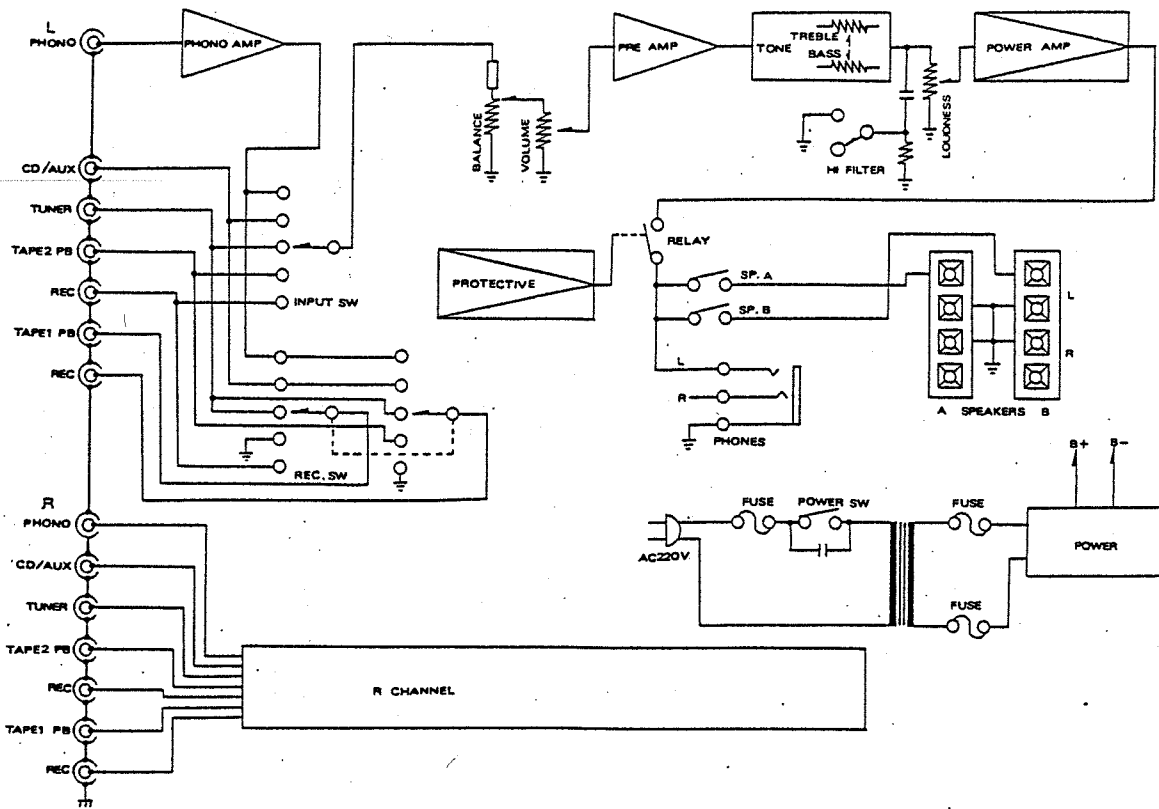

5 IC BLOCK DIAGRAM

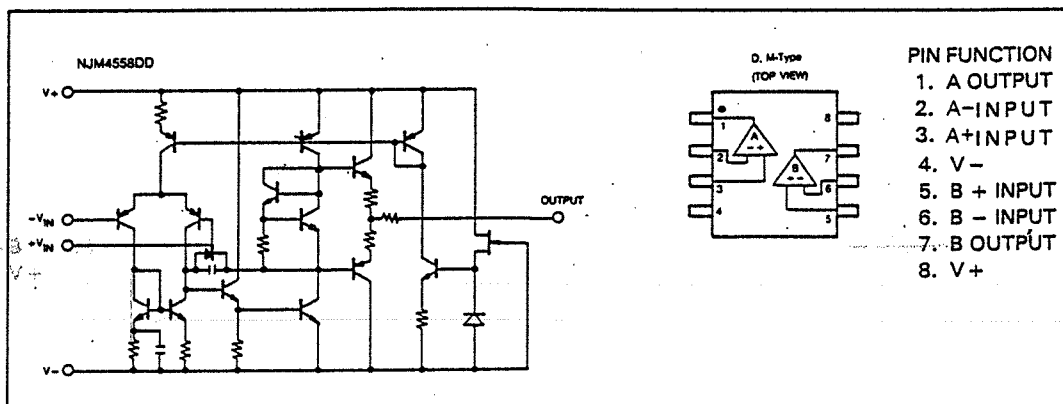
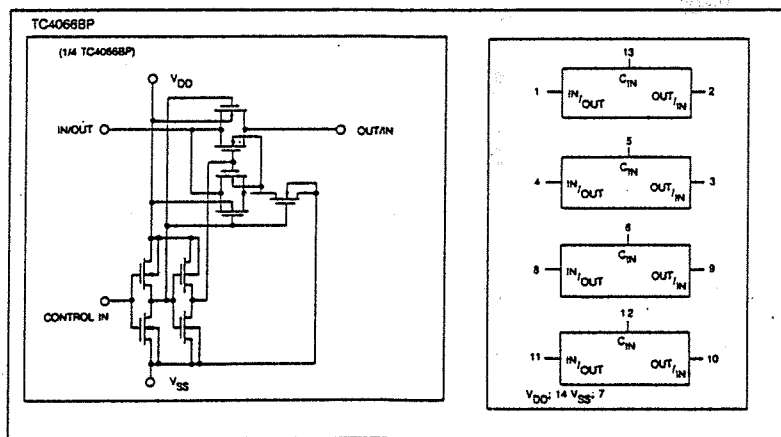

6 EXPLODED VIEW A-X55

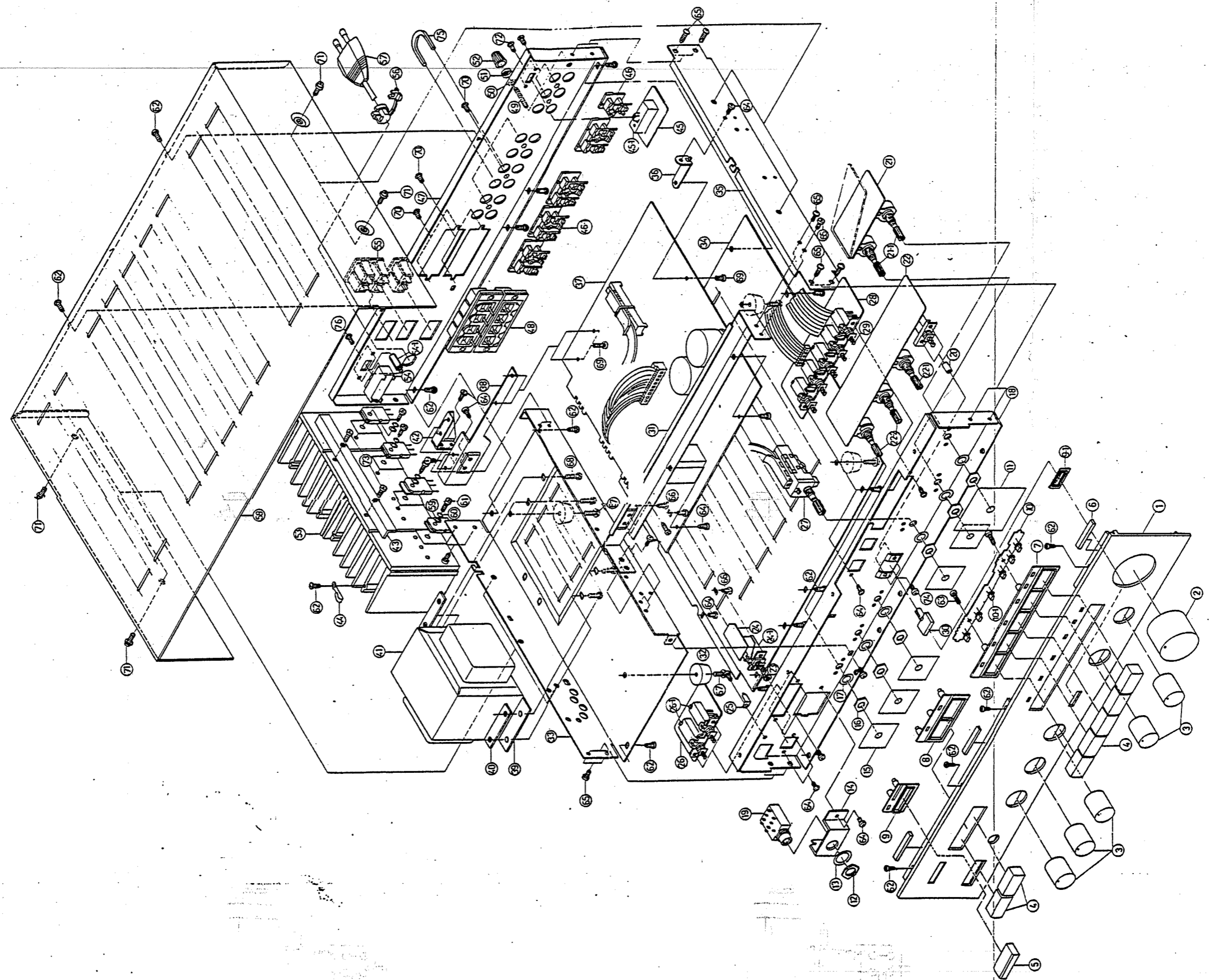

7 SCHEMATIC DIAGRAM

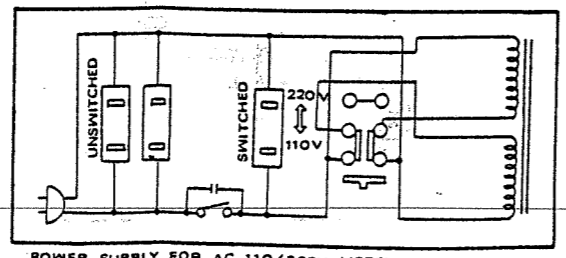
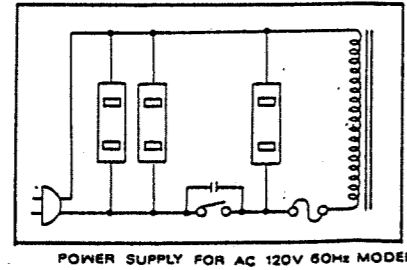
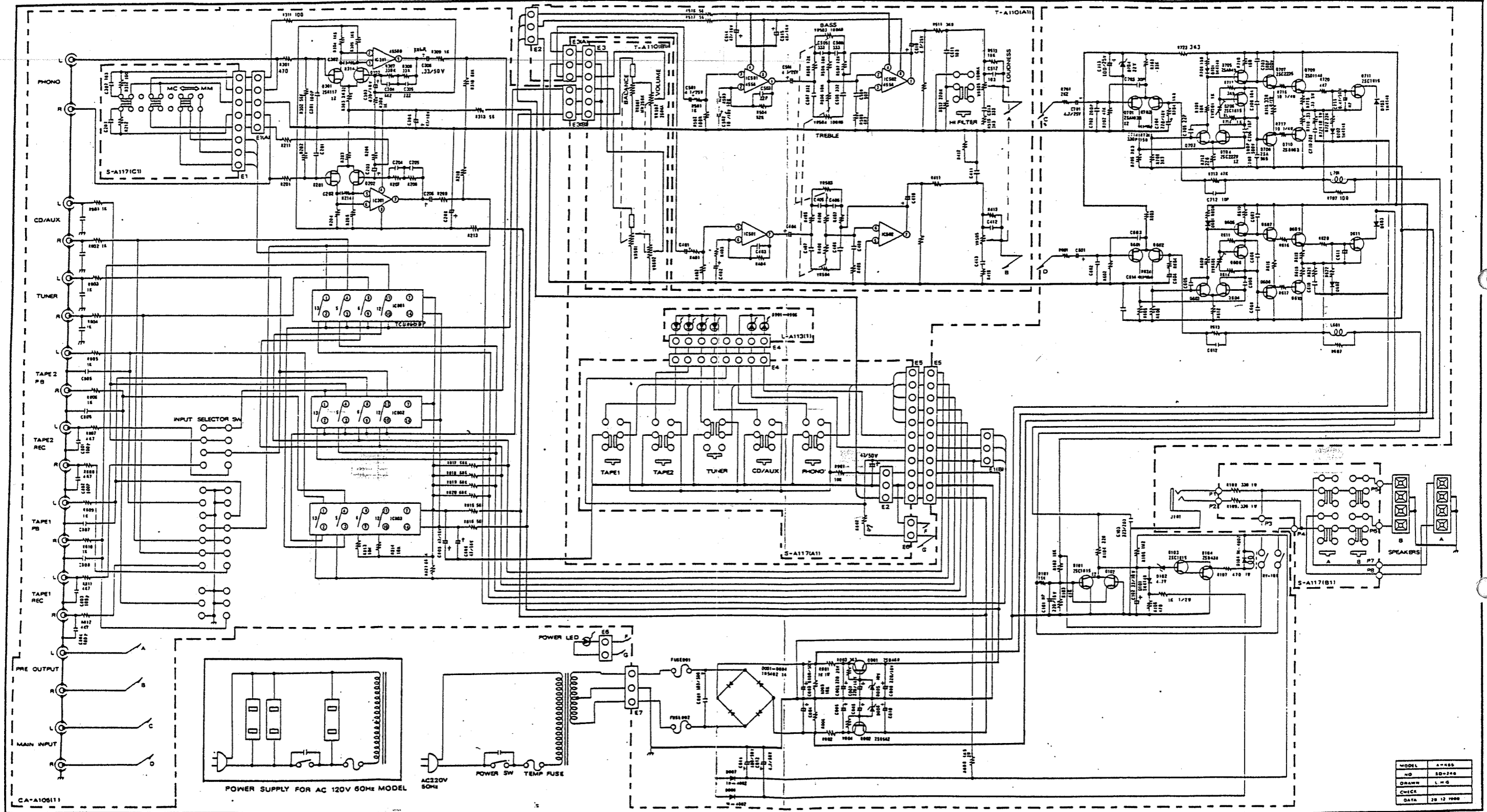

MODEL	A-X55
NO	SD-248
DRAWN	L.W.B.
CHECK	
DATE	28 12 1988

1
2
3
4
5
6
7
8
9
10
11
12
13
14
15
16
17
18
19
20
21
22
23
24
25
26
27
28
29
30
31
32
33
34
35
36
37
38
39
40
41
42
43
44
45
46
47
48
49
50
51
52
53
54
55
56
57
58
59
60

8 EXPLODED VIEW AND PARTS LIST

EXPLODED VIEW

REF. NO.	PARTS NO.	DESCRIPTION	REMARKS
1.	PNLAL0186X555	Front Panel L-186	
2.	KNBRT0169B**9	Knob KB-169BK	
3.	KNBRT0143B**2	Knob KB-143BK	
4.	KNBKYO168B**1	Push Knob KB-168B	
5.	KNBKYO167B**8	Push Knob KB-167B	
6.	RUB4000800506	Sponge Cushion 40x8x5	
7.	GSKKB0196B**9	Washer for Push Knob A-196	
8.	GSKKB0196B**9	Washer for Push Knob A-196	
9.	GSKKB0194B**5	Washer for Push Knob A-194	
9-1.	GSKKB0195B**7	Washer for Push Knob A-195	
10.	PCBL*0A113A16	LED PCB L-A113(A1)	
10-1.	LED050020GS*7	Indicator LED 2x5 Green	
11.	CLT05005005*6	Flet D-0032A	
12.		Nut M12	
13.		Washer 12.1Ø	
14.	CHAC*0495CA20	Phone Jack Holder C-495	
15.	CLT02802825*2	Flet D-0031A	
16.		Nut M7x0.75	
17.		Washer 7.2Ø	
18.	CHAC*0907X554	Front Chassis C-907	
19.	EJKHL230603P3	Phone Jack HTJ084-040	
20.	STNA*0213***8	Plastic Post A-213	
21.	PCBT*0A110B24	PCB T-A110(B2)	
21-1.	RVR100K18AZ11	VR 250KA x 2x25 KA162B0D218	
21-2.	RVR250K25MC20	VR MN250K x 2x25 K162A0A046	
22.	PCBT*0A110A24	PCB T-A110(A2)	
22-1.	RVR100K25AT26	VR 100KA x 2x25 RKDA20B225	
22-2.	RVR100K25BE27	VR 100KB x 2x25 K162A0B311	
23.	FBW04010010*9	Insulation Washer 4.2Ø x 8	
24.	PCBS*0A517A*2	PCB S-A517A	
24-1.	PWSES88213**1	Power Switch SDL-B1P(TV3)	
25.	SDY54030****1	Weld 3Ø	
26.	PCBS*0A117B24	PCB S-A117(B2)	
26-1.	PHSSUF51AE186	Push Switch SPUF21CE11	
27.	FLSESA23326*1	Remote Switch ESA-23326	
28.	PBCS*0A117A24	PCB S-A117(A2)	
29.	PHSSUF51AE186	Push Switch SPUF51AE18	
30.	KNBRT0092B**0	Push Knob KB-092B	
31.	CHAC*05776A26	Aux Holder C-577	
32.	FTP**0018***1	Foot Cushion 18Ø x 10m/m	
33.	CHAC*0487CA21	Left Chassis C-487	
34.	CHAC*0489CA25	Bottom Chassis	
35.	CHACR0488CA21	Right Chassis C-488	
36.	CHAC*0584GA23	PCB Holder C-584	
37.	PCBCA0A105*24	Main PCB CA-A105(I2)	
38.	CHAC*0576GA24	Heat Sink Holder C-576A	
39.	CHAC*0496GA26	Transformer Holder C-579	
40.	CHAC*0575CA29	Transformer Holder C-575	
41.		Transformer	EUR
		Transformer	EUR UK
		Transformer	CND
		Transformer	EX
42.	CHAC*0494CA29	Heat Sink Holder C-494	
43.	CHAC*0498CA28	L Holder C-498	
44.	CLP**0000***1	Weld 3.2Ø	
45.	PCBS*0A117C24	PCB S-A117(C2)	
45-1.	SLSPO62BCPA63	Slide Switch P062BC-PA6	
46.	RCKYK00080290	2P RCA Jack	
46-1.	RCKYK000904P2	4P RCA Jack KC21-009	
47.	CHAC*0908X556	Rear Panel C-908	
48.	SPKPT0104LY*4	Speaker Terminal PT-104L-Y	
49.	SCEOM0503*CE7	Ground Screw E-178	
50.	SLSESA26142*4	Slide Switch ESA-26142	
51.	BLTSW30306B*9	Remove Wire ESA-30306B	
52.	LED050020ORS*	LED 2x5 Orange Red	
53.	RAPH*0043***3	Heat Sink H-043A	
54.	SLSPO62BCPA63	Slide Switch P062BCO-PA6	(EX)
54-1.	STNVC100180*1	Copper Post E-161	
55.	ACLRT0021***2	AC Outlet R7-21	EX
	ACKS*16519**8	AC Outlet S-16519	CND
56.	CLPB*0007***5	Bushing B-7	
57.		AC Cord SPT-2AWG 18x2C	EX
		AC Cord SPT-2AWG 18x2C	
		(POLARZED)	USA, CND
		AC Cord CEEx2C	EUR
		AC Cord BS 6500	EUR UK
		AC Cord SAA	AUS
58.	CHAC*0490CA21	Upper Cover C-490	
59.	FBW04010010*9	Insulation Washer 3.2Ø	
60.	FTW03208005*7	Washer 3Ø	

REF. NO.	PARTS NO.	DESCRIPTION	REMARKS
61.	SCECT030016*1	Screw CRTS 3x16	
62.	SCECT30068C*6	Screw CRTS 3x6	
63.	SCECM3006YC*9	Screw CRMS 3x6	
64.	SCECT3006YC*7	Screw CRTS 3x6	
65.	SCECT3006YC*7	Screw CRTS 3x6	
66.	SCECT3508YC*9	Screw CRTS 3.5x8	
67.	SCECM4008BW*6	Screw CRWMS 4x8	
68.	SCECM4010YS*5	Screw CRMS 4x10	
69.	SCECT3008BC*1	Screw CRTS 3x8	
70.	SCECT0109BCP7	Plastic Screw 1/8x9	
71.	SCECM40068C*2	Screw CRWMS 4x6	
72.	SCECT26048C*1	Screw CRMS 2.6x4	
73.	SCECT3006*YC7	Screw CRTS 3x6	
74.	SCECM3012YC*4	Screw CRMS 3x12	
75.	SDY32E*0037X8	"U" Jump Wire	
76.	SCECM3006BC*8	Screw CRTS 3x6	
77.	SCECT3008BU*1	Slotted Head Screw CRTS 3x8	
78.	SCECT3058BC*1	Screw CRTS 3.5x8	
79.	ITDA**OX35*38	Owner's Manual	
80.		Styrofoam PT-045	
81.		Inside carton	
82.		Outside carton (Two in one)	

PC BOARD AND PARTS LIST

3.1 MAIN AMP PCB CA-A105(2)

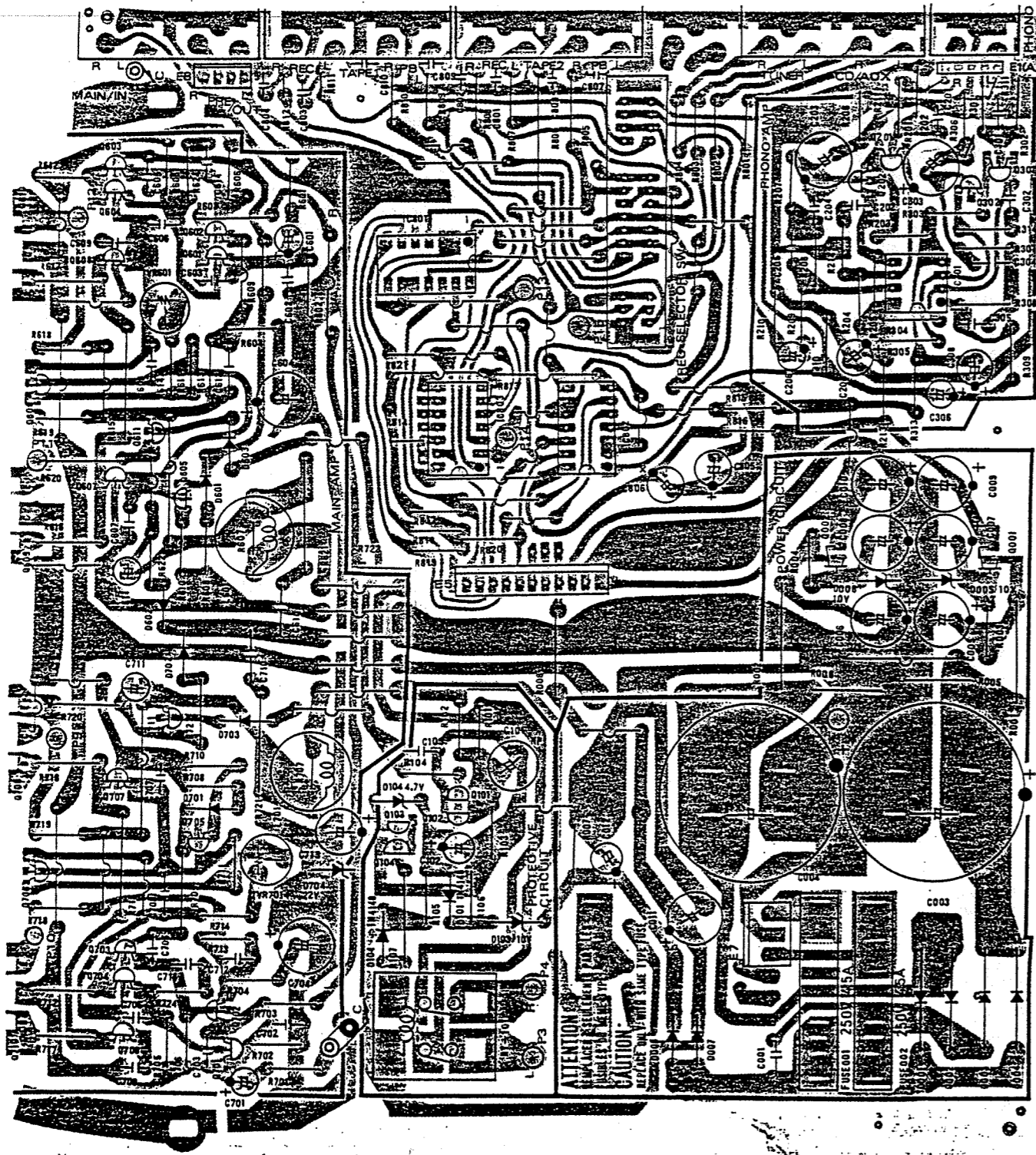

MAIN AMP PCB ASSY CA-A105(2)

REF. NO.	PARTS NO.	DESCRIPTION
	PCBCA0A105*24	MAIN AMP PCB ASSY
	PCBCA0A105*24	MAIN AMP PCB
-IC'S-		
IC301	ICCNJ04558DD6	NJM4558DD
IC801-IC803	ICCCD04086AE9	TC4066BP
-TRANSISTORS-		
Q001	TRSSD0468C**8	2SD468
Q002	TRSSB0562C**8	2SB562
Q101, Q102	TRSSC1815GR*4	2SC1815GR
Q103	TRSSC1815BL*1	2SC1815BL
Q104	TRSSD0438F**0	2SD438
Q201, Q301	TRSSK0117BL*7	2SK117BL
Q202, Q302	TRSSK0117BL*7	2SK117BL
Q601, Q701	TRSSA1038E**3	2SA1038
Q602, Q702	TRSSA1038E**3	2SA1038
Q603, Q703	TRSSC2229Y**3	2SC2229Y
Q604, Q704	TRSSC2229Y**3	2SC2229Y
Q605, Q705	TRSSA0949Y**4	2SA949Y
Q606, Q706	TRSSC1815BL*1	2SC1815BL
Q607, Q707	TRSSC2235Y**9	2SC2235Y
Q608, Q708	TRSSA0965Y**2	2SA965Y
Q609, Q709	TRSSD11480**5	2SD1148
Q610, Q710	TRSSB08630**1	2SB863
Q611, Q711	TRSSC1815GR*4	2SC1815GR
-DIODES-		
D001, D004	DIDIN5402***1	1N5402
D005, D006	DIDO10V0W5**2	10V 0.5W
D007, D008	DIDIN4002***2	1N4002
D101	DIDIN4148***8	1N4148
D102	DIDO4V70W5**9	4.7V 0.5W
D104	DIDIN4002***2	1N4002
D601-D603	DIDIN4148***8	1N4148
D701-D703	DIDIN4148***8	1N4148
D704	DIDO22V0W5**7	22V 0.5W
-CARBON RESISTORS-		
All resistors are rated ±5% tolerance and 1/4W		
R003, R004	CBR03K30W4TJ4	3K3 ohm
R101, R102	CBR015K0W4TJ0	15K ohm
R103	CBR047K0W4TJ6	47K ohm
R104	CBR220R0W4TJ1	220 ohm
R105	CBR01M20W4TJ9	1M2 ohm
R201, R301	CBR022R0W4TJ8	22 ohm
R202, R302	CBR056K0W4TJ7	56K ohm
R206, R306	CBR001K0W4TJ7	1K ohm
R209, R309	CBR001K0W4TJ7	1K ohm
R210, R310	CBR068K0W4TJ1	68K ohm
R211, R311	CBR100R0W4TJ4	100 ohm
R213, R313	CBR056R0W4TJ2	56 ohm
R214, R314	CBR150R0W4TJ1	150 ohm
R601, R701	CBR02K20W4TJ5	2K2 ohm
R602, R702	CBR047K0W4TJ8	47K ohm
R603, R703	CBR033K0W4TJ2	33K ohm
R604, R704	CBR01K80W4TJ1	1K8 ohm
R605, R705	CBR03K30W4TJ4	3K3 ohm
R606, R706	CBR03K30W4TJ4	3K3 ohm
R608, R708	CBR150R0W4TJ1	150 ohm
R609, R709	CBR01K0W4TJ8	10K ohm
R610, R710	CBR150R0W4TJ1	150 ohm
R611, R711	CBR03K90W4TJ6	3K9 ohm
R612, R712	CBR220R0W4TJ1	220 ohm
R613, R713	CBR047K0W4TJ6	47K ohm
R614, R714	CBR001K0W4TJ7	1K ohm
R616, R716	CBR010R0W4TJ3	10 ohm
R617, R717	CBR010R0W4TJ3	10 ohm
R620, R720	CBR04K70W4TJ4	4K7 ohm
R622, R722	CBR022K0W4TJ2	22K ohm
R723	CBR03K30W4TJ4	3K3 ohm
R624, R724	CBR150R0W4TJ1	150 ohm
R801-R806	CBR001K0W4TJ7	1K ohm
R807, R808	CBR04K70W4TJ4	4K7 ohm
R809, R810	CBR001K0W4TJ7	1K ohm
R815, R816	CBR470R0W4TJ1	470 ohm
R817-R821	CBR068K0W4TJ1	68K ohm

All resistors are rated ±5% tolerance and 1/4W F Tape

REF. NO.	PARTS NO.	DESCRIPTION
R607, R702	CBR010R0W4FJ3	10 ohm
R811, R812	CBR04K70W4FJ4	4K7 ohm
R813, R814	CBR068K0W4FJ1	68K ohm
All resistors are rated ±5% tolerance and 1/2W		
R005, R006	CBR010K0W2TJ6	10K ohm
R008	CBR01K50W2TJ9	1K5 ohm
	CBR001K0W2TJ5	1K ohm
R106	CBR001K0W2TJ1	1K ohm
All resistors are rated ±5% tolerance and 1/3W		
R615, R715	CBR330R0W3TJ2	330 ohm
-ETAL FILM RESISTORS-		
All resistors are rated ±5% tolerance and 1/4W		
R203, R303	PMR03K30W4TG5	3K3 ohm
R204, R304	PMR01K50W4TG1	1K5 ohm
R205, R305	PMR01K50W4TG1	1K5 ohm
R207, R307	PMR03K30W4TG3	33K ohm
R208, R308	PMR330K0W4TG9	330K ohm
All resistors are rated ±5% tolerance and 1W		
R001, R002	MTR001K01WTJ8	1K ohm
R107	MTR470R01WTJ2	470 ohm
R621, R721	MTR010R01WTJ4	10 ohm
-CEMENT-FILLED FIXED RESISTORS-		
All resistors are rated ±5% tolerance with 5W		
R618, R718	CMR0R3305WTE9	0.33 ohm
R619, R719	CMR0R3305WTE9	0.33 ohm
-CAPCITORS-		
C001	CRC0P0101KRZ1	Ceramic 0.01u 500V
C003, C004	ELC06K8050R35	Elec. 6800u 50V
C005, C006	ELC220U025R38	Elec. 220u 25V
C007-C010	ELC220U016R37	Elec. 220u 16V
C011	ELC100U050R31	Elec. 100u 50V
C012	ELC04U7050R54	Elec. 4.7u 50V KULR
C101	ELC220U016R01	Elec. 220u 16V NP
C102	ELC033U010R38	Elec. 33u 10V
C103	PECU022050RK3	Mylar 0.022K
C201, C301	CRC0100050RK5	Ceramic 100P 50V
C202, C302	CRC0330050RK1	Ceramic 330P 50V
C203, C303	ELC470U016R37	Elec. 470u 16V
C204, C304	PEC2000050RJ5	Mylar 0.002u 50V
C205, C305	PECU022500RK3	Mylar 0.0068u 50V
C206, C306	ELC0U33050R55	Elec. 0.33u 50V
C208, C308	ELC047U016R37	Elec. 47u 16V
C601, C701	ELC04U7025R35	Elec. 4.7u 25V
C602, C702	CRC020050RK5	Ceramic 200P 50V
C604, C704	ELC220U016R37	Elec. 220u 16V
C605, C705	CRC0022500RK0	Ceramic 22P 500V
C606, C706	CRC0015500RK7	Ceramic 15P 500V
C607, C707	CRC0100050RK5	Ceramic 100P 50V
C608, C708	PEC00U1050RK3	Ceramic 0.1u 50V
C609, C709	CRC0100050RK5	Ceramic 100P 50V
C610, C710	PECU022050RK3	Mylar 0.022u 50V
C611, C711	ELC0U47050R09	Elec. 0.47u 50V NP
C612, C712	CRC0010500RK9	Ceramic 10P 500V
C713	ELC100U025R30	Elec. 100P 25V
C614, C714	CRC0330050RK4	Ceramic 330P 500V
C801-C804	CRC0100050RK4	Ceramic 100P 50V
C805, C806	ELC047U016R37	Elec. 47u 16V
C807-C810	CRC0100050RK5	Ceramic 100P 50V
-VARIABLE RESISTORS-		
TVR001, TVR701	TVR001K063HM1	60H 1K ohm
-COILS-		
L601, L701	CIL1851000186	18 1/2T
-MISCELLANEOUS-		
	RCKYK000904P2	4P RCA Jack
	CHAPC02023**5	2P RCA Jack
	CNT**514311P1	Wafer Connector 11P
RY-101	RLY24V5A2P2C1	Relay
	SLSESA26142*4	Slide Switch
	SDY43SQ1119*8	Pin 1 x 1 x 9
	FUJFH0003***1	Fuse Holder
	RAPH*0043***3	Heat Sink

9.2 POWER SWITCH PCB S-A517A
 SWITCH PCB S-A117(B2,C2)
 TONE AMP PCB T-A110(A2,B2)
 FUNCTION SWITCH PCB S-A117(A2)
 FUNCTION LED PCB L-A113(A1)
 POWER LED PCB L-A113(B1)

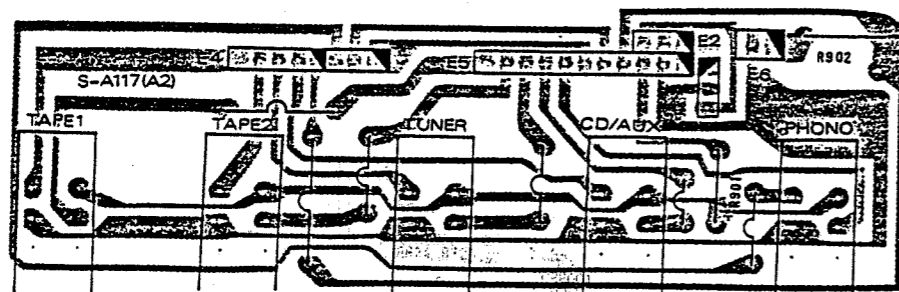
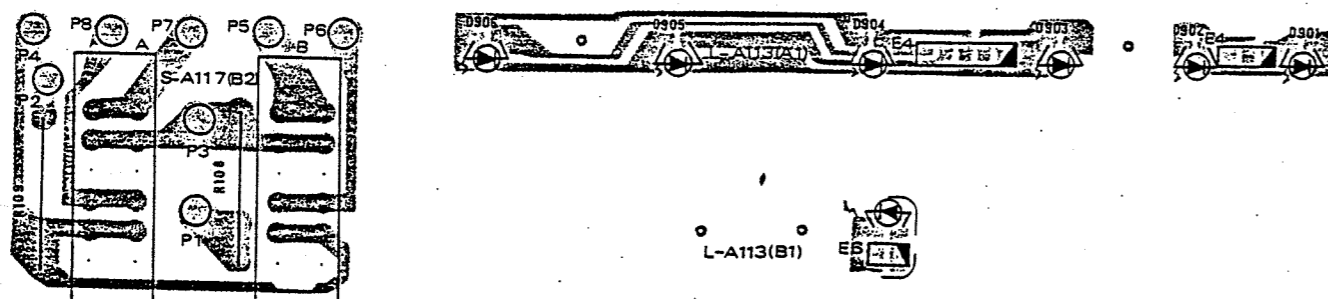
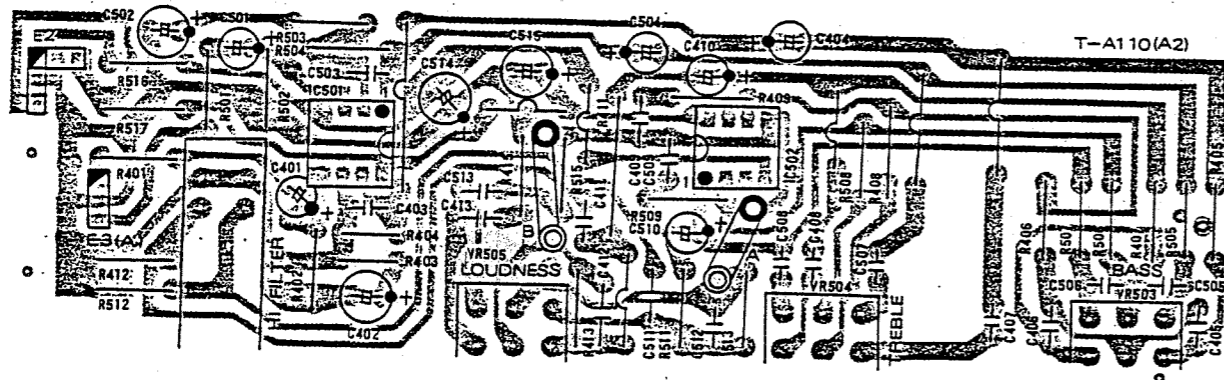
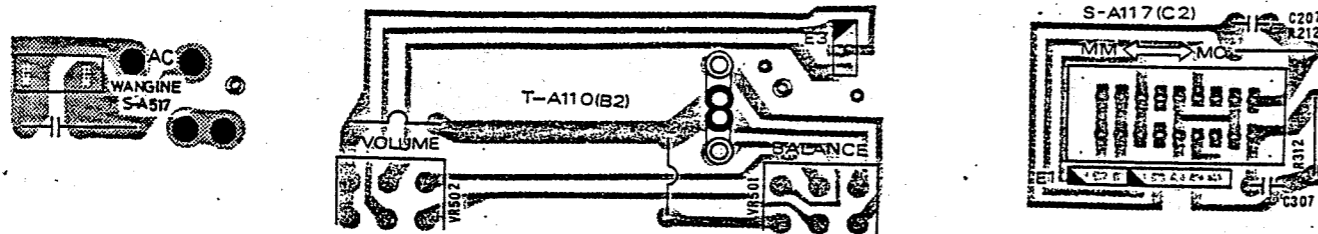

TONE AMP PCB ASSY T-A110(A2)

REF. NO.	PARTS NO.	DESCRIPTION
	PCBT*0A110A24	TONE AMP PCB ASSY
	PCBT*0A110A24	TONE AMP PCB
		-IC'S-
IC501	ICCNJ02043D*2	NJM2043D
IC502	ICCNJ04558DD6	NJM4558DD
		-CARBON RESISTORS-
		All resistors are rated ±5% tolerance and 1/4W
R401, R501	CBR001K0W4TJ7	1K ohm
R402, R502	CBR100K0W4TJ9	100K ohm
R403	CBR010K0W4FJ8	10K ohm F Type
R404	CBR082K0W4FJ5	82K ohm F Type
R405, R505	CBR012K0W4TJ7	12K ohm
R406, R506	CBR010K0W4TJ8	10K ohm
R407, R507	CBR012K0W4TJ7	12K ohm
R408, R508	CBR010K0W4TJ8	10K ohm
R409, R509	CBR04K70W4TJ4	4K7 ohm
R411, R511	CBR03K90W4TJ6	3K9 ohm
R412, R512	CBR220K0W4TJ6	220K ohm
R413, R513	CBR018K0W4TJ4	18K ohm
R415, R515	CBR03K30W4TJ4	3K3 ohm
R503	CBR010K0W4TJ8	10K ohm
R504	CBR082K0W4TJ5	82K ohm
		-CAPCITORS-
C401, C501	ELC04U7025R35	Elec. 4.7u 25V
C402, C502	ELC100U010R34	Elec. 100u 10V
C403, C503	CRC0010050RK4	Ceramic 10P 50V
C404, C504	ELC04U7025R35	Elec. 4.7u 25V
C405, C505	PECU033050RJ2	Mylar 0.033u 50V
C406, C506	PECU033050RJ2	Mylar 0.033u 50V
C407, C507	PEC3300050RJ8	Mylar 0.0033u 50V
C408, C508	PEC3300050RJ8	Mylar 0.0033u 50V
C409, C509	PEC4700050RJ6	Mylar 0.005u 50V
C410, C510	ELC04U7025R35	Elec. 4.7u 25V
C411, C511	PEC6800050RJ4	Mylar 0.0068u 50V
C412, C512	PEC0U1050RJ8	Mylar 0.01u 50V
C413, C513	PECU033050RJ2	Mylar 0.033u 50V
C514, C515	ELC047U016R37	Elec. 47u 16V
		-VARIABLE RESISTORS-
VR503, VR504	RVR100K25BE27	100KB x 2
VR505	RVR100K25AT26	100KA x 2
		-MISCELLANEOUS-
	PHSSUF12AE157	Push Switch
	PRL11002403P4	Connector 3P x 110 m/m

TONE AMP PCB ASSY T-A110(B2)

REF. NO.	PARTS NO.	DESCRIPTION
	PCBT*0A110B24	TONE AMP PCB ASSY
	PCBT*0A110B24	TONE AMP PCB
		-VARIABLE RESISTORS-
VR501	RVR250K25MC20	MN250K x 2
VR502	RVR100K18AZ11	250KA

FUNCTION SWITCH PCB ASSY S-A117(A2)

REF. NO.	PARTS NO.	DESCRIPTION
	PCBS*0A117A24	FUNCTION SWITCH PCB ASSY
	PCBS*0A117A24	FUNCTION SWITCH PCB
		-CARBON RESISTORS-
		All resistors are rated ±5% tolerance and 1/4W
R901	CBR010K0W4TJ8	10K ohm
VR502	CBR047ROW4TJ8	47 ohm
		-MISCELLANEOUS-
	PHSSUF51AE185	Push Switch
	CNT**549408P7	Wafer Connector 8P
	PRL17002405P7	Connector 5P x 130
	PRL17002605P7	Connector 6P x 170
	SDY43SO1119*8	Pin 1 x 1 x 9

SWITCH PCB ASSY S-A117(B2)

REF. NO.	PARTS NO.	DESCRIPTION
	PCBS*0A117B24	SWITCH PCB ASSY
	PCBS*0A117B24	SWITCH PCB
		-METAL FILM RESISTORS-
R108, R109	MTR330R01WTJ4	330 ohm 1W
	PHSSUF21CE115	Push Switch

SWITCH PCB ASSY S-A117(C2)

REF. NO.	PARTS NO.	DESCRIPTION
	PCBS*0A117C24	SWITCH PCB ASSY
	PCBS*0A117C24	SWITCH PCB
		-CARBON RESISTORS-
		All resistors are rated ±5% tolerance and 1/4W
R212, R312	CBR100RGW4TJ4	100 ohm
		-MISCELLANEOUS-
C207, C307	PEC0U01050RJ8	Mylar 0.01u 50V
	PRL10002405P9	Connector 5P x 110
	PRL17002403P7	Connector 3P x 170
	PCBS*0A117C24	Slide Switch

FUNCTION LED PCB ASSY L-A113(A1)

REF. NO.	PARTS NO.	DESCRIPTION
	PCBL*0A113A26	FUNCTION LED PCB ASSY
	PCBL*0A113A26	FUNCTION LED PCB
D-901-D906	LED050020GS*7	LED 2 x 5 Green
	PRL11002403P4	Connector 3P x 110
	PRL10002405P9	Connector 5P x 110
	GSKXB0198B**9	Washer

POWER LED PCB ASSY L-A113(B2)

REF. NO.	PARTS NO.	DESCRIPTION
	PCBL*0A113B26	POWER LED PCB ASSY
	PCBL*0A113B26	POWER LED PCB
		-MISCELLANEOUS-
	LED050020RS*7	LED 2 x 5 Red
	GSKXB01948*5*	Washer
	SCECT2606YC*4	Screw CRTS 2.6 x 6

POWER SWITCH PCB ASSY S-A517A

REF. NO.	PARTS NO.	DESCRIPTION
		POWER SWITCH PCB ASSY
		POWER SWITCH PCB
		-MISCELLANEOUS-
	CRC0P0101KRZ1	Ceramic 0.01u 1000V
	PWSES82131*1	Power Switch
	SCECT2606YC*4	Screw CRTS 2.6 x 6

TEAC

Original

A-X55

DC Integrated Stereo Amplifier

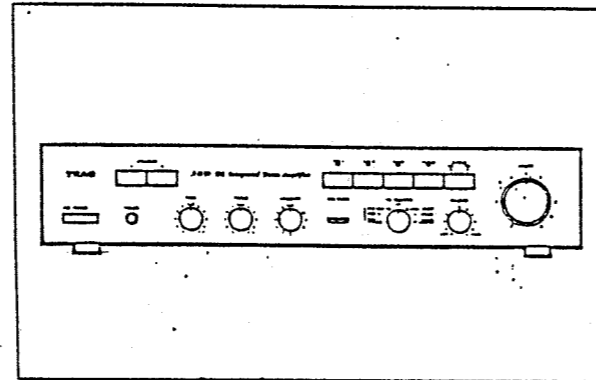

SERVICE MANUAL

EXPLODED VIEW A-X55

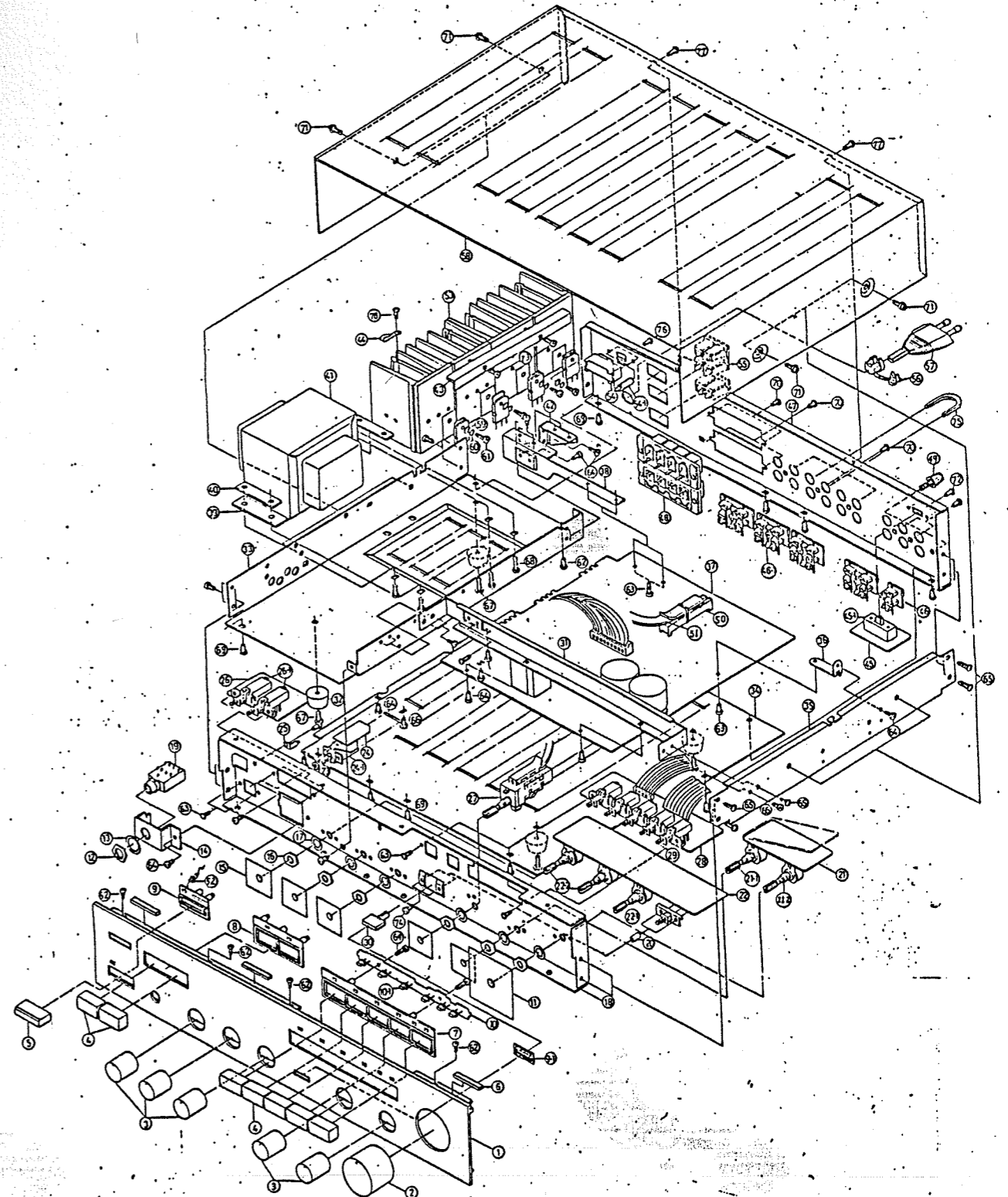

EXPLODED VIEW

RES. NO.	PARTS NO.	DESCRIPTION	REMARKS
1.	PNLAL0186X555	Front Panel L-186	
2.	KNBRT0169B**9	Knob KB-169BK	
3.	KNBRT0143B**2	Knob KB-143BK	
4.	KNBKY0168B**1	Push Knob KB-168B	
5.	KNBKY0167B**8	Push Knob KB-167B	
6.	RUB4000800506	Sponge Cushion 40x8x5	
7.	GSKKB0196B**9	Washer for Push Knob A-196	
8.	GSKKB0196B**9	Washer for Push Knob A-196	
9.	GSKKB0194B**5	Washer for Push Knob A-194	
9-1.	GSKKB0195B**7	Washer for Push Knob A-195	
10.	PCBL*0A113A16	LED PCB L-A113(A1)	
10-1.	LED050020GS*7	Indicator LED 2x5 Green	
11.	CLT05005005*6	Flet D-0032A	
12.		Nut M12	
13.		Washer 12.1Ø	
14.	CHAC*0495CA20	Phone Jack Holder C-495	
15.	CLT02802825*2	Flet D-0031A	
16.		Nut M7x0.75	
17.		Washer 7.2 Ø	
18.	CHAC*0907X554	Front Chassis C-907	
19.	EJKHL230603P3	Phone Jack HTJ064-04D	
20.	STNA*0213**8	Plastic Post A-213	
21.	PCBT*0A110B24	PCB T-A110(B2)	
21-1.	RVR100K18AZ11	VR 250Kax2x25 KA162B0D218	
21-2.	RVR250K25MC20	VR MN250Kx2x25 K162A0A046	
22.	PCBT*0A110A24	PCB T-A110(A2)	
22-1.	RVR100K25AT26	VR 100Kax2x25 RKDA20B225	
22-2.	RVR100K25BE27	VR 100KBx2x25 K162A0B311	
23.	FBW04010010*9	Insulation Washer 4.2Ø x8	
24.	PCBS*0A517A*2	PCB S-A517A	
24-1.	PWSESB8213**1	Power Switch SDL-B1P (TV3)	
25.	SDY54030****1	Weld 3Ø	
26.	PCBS*0A117B24	PCB S-A117(B2)	
26-1.	PHSSUF51AE186	Push Switch SPUF21CE11	
27.	FLSESA23326*1	Remote Switch ESA-23326	
28.	PBCS*0A117A24	PCB S-A117(A2)	
29.	PHSSUF51AE186	Push Switch SPUF51AE18	
30.	KNBRT0092B**0	Push Knob KB-092B	
31.	CHAC*05776A26	Aux Holder C-577	
32.	FTP**0018***1	Foot Cushion 18Øx10m/m	
33.	CHAC*0487CA21	Left Chassis C-487	
34.	CHAC*0489CA25	Bottom Chassis	
35.	CHACR0488CA21	Right Chassis C-488	
36.	CHAC*0584GA23	PCB Holder C-584	
37.	PCBCA0A105*24	Main PCB CA-A105(2)	
38.	CHAC*0576GA24	Heat Sink Holder C-576A	
39.	CHAC*0496GA26	Transformer Holder C-579	
40.	CHAC*0575CA29	Transformer Holder C-575	
41.	CHAC*0497GA28	Transformer Holder C-580	
42.	CHAC*0494CA29	Heat Sink Holder C-494	
43.	CHAC*0498CA26	L Holder C-498	

RES. NO.	PARTS NO.	DESCRIPTION	REMARKS
44.	CLP**0000***1	Weld 3.2 Ø	
45.	PCBS*0A117C24	PCB S-A117(C2)	
45-1.	SLSP062BCPA63	Slide Switch P062BC-PA6	
46.	RCKYK00080290	2P RCA Jack	
46-1.	RCKYK000904P2	4P RCA Jack KC21-009	
47.	CHAC*0908X556	Rear Panel C-908	
48.	SPKPT0104LY*4	Speaker Terminal PT-104L-Y	
49.	SCEOM0503*CE7	Ground Screw E-176	
50.	SLSESA26142*4	Slide Switch ESA-26142	
51.	BLTSW30306B*9	Remove Wire ESA-30306B	
52.	LED0500200RS*	LED 2x5 Orange Red	
53.	RAPH*0043***3	Heat Sink H-043A	
54.	SLSP062BCPA63	Slide Switch P062BC0-PA6	(EX)
54-1.	STNVC100180*1	Copper Post E-161	
55.	ACLRT0021***2	AC Outlet R7-21	EX
	ACKS*16519**8	AC Outlet S-16519	CND
56.	CLPB*0007***5	Bushing B-7	
57.		AC Cord SPT-2AWG 18x2C	EX
		AC Cord SPT-2AWG 18x2C	
		(POLARZED)	USA, CND
		AC Cord CEEx2C	EUR
		AC Cord BS 6500	EUR UK
		AC Cord SAA	AUS
58.	CHAC*0490CA21	Upper Cover C-490	
59.	FBW04010010*9	Insulation Washer 3.2Ø	
60.	FTW03208005*7	Washer 3Ø	
61.	SCECT030016*1	Screw CRTS 3x16	
62.	SCECT3006BC*6	Screw CRTS 3x6	
63.	SCECM3006YC*9	Screw CRMS 3x6	
64.	SCECT3006YC*7	Screw CRTS 3x6	
65.	SCECT3006YC*7	Screw CRTS 3x6	
66.	SCECT3508YC*9	Screw CRTS 3.5x8	
67.	SCECM4008BW*6	Screw CRWMS 4x8	
68.	SCECM4010YS*5	Screw CRMS 4x10	
69.	SCECT3008BC*1	Screw CRTS 3x8	
70.	SCECT0109BCP7	Plastic Screw 1/8x9	
71.	SCECM4006BC*2	Screw CRWMS 4x6	
72.	SCECT2604BC*1	Screw CRMS 2.6x4	
73.	SCECT3006*YC7	Screw CRTS 3x6	
74.	SCECM3012YC*4	Screw CRMS 3x12	
75.	SDY32E*0037X8	"U" Jump Wire	
76.	SCECM3006BC*8	Screw CRTS 3x6	
77.	SCECT3008BU*1	Slotted Head Screw CRTS 3x8	
78.	SCECT3058BC*1	Screw CRTS 3.5x8	

507
75CA
97GA26
CA29 Hea
Hold

507
75CA
97GA26
CA29 Hea
Hold

TONE AMP PCB T-A110(A2,B2)
 FUNCTION SWITCH PCB S-A117(A2)
 SWITCH PCB S-A117(B2,C2)
 FUNCTION LED PCB L-A113(A1)
 POWER LED PCB L-A113(B1)
 POWER SWITCH PCB S-A517A

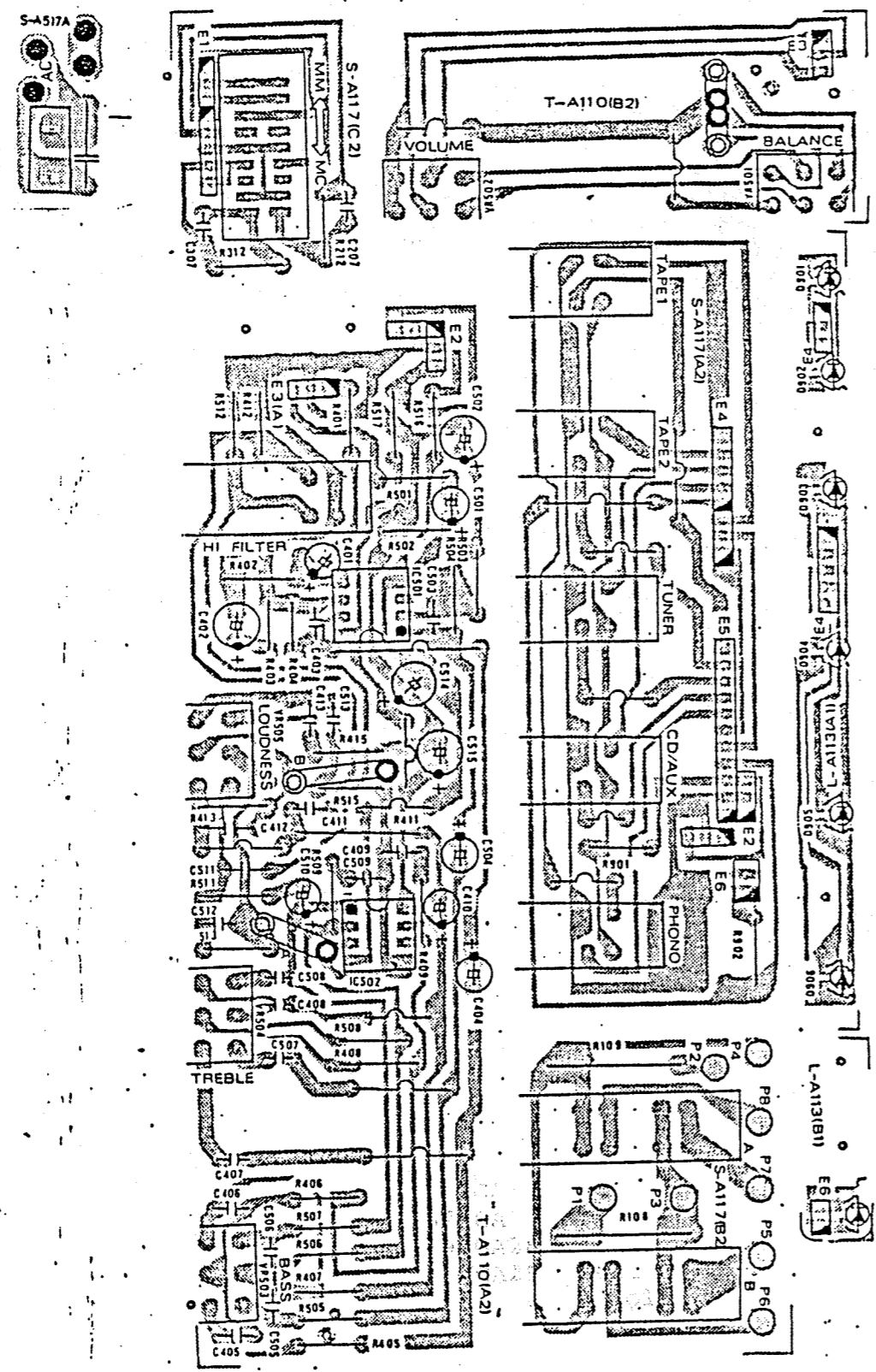

MAIN AMP PCB ASSY CA-A105(2)

REF. NO.	PARTS NO.	DESCRIPTION
	PCBCA0A105*24	MAIN AMP PCB ASSY
	PCBCA0A105*24	MAIN AMP PCB

-IC'S-

IC301	ICCNJ04558DD6	NJM4558DD
IC801-IC803	ICCCD04066AE9	TC4066BP

-TRANSISTORS-

Q001	TRSSD0468C**6	2SD468
Q002	TRSSB0562C**8	2SB562
Q101, Q102	TRSSC1815GR*4	2SC1815GR
Q103	TRSSC1815BL*1	2SC1815BL
Q104	TRSSD0438F**0	2SD438
Q201, Q301	TRSSK0117BL*7	2SK117BL
Q202, Q302	TRSSK0117BL*7	2SK117BL
Q601, Q701	TRSSA1038E**3	2SA1038
Q602, Q702	TRSSA1038E**3	2SA1038
Q603, Q703	TRSSC2229Y**3	2SC2229Y
Q604, Q704	TRSSC2229Y**3	2SC2229Y
Q605, Q705	TRSSA0949Y**4	2SA949Y
Q606, Q706	TRSSC1815BL*1	2SC1815BL
Q606, Q707	TRSSC2235Y**9	2SC2235Y
Q608, Q708	TRSSA0965Y**2	2SA965Y
Q609, Q709	TRSSD11480**5	2SD1148
Q610, Q710	TRSSB08630**1	2SB863
Q611, Q711	TRSSC1815GR*4	2SC1815GR

-DIODES-

D001, D004	DIDIN5402***1	1N5402
D005, D006	DID010V0W5**2	10V 0.5W
D007, D008	DIDIN4002***2	1N4002
D101	DIDIN4148***8	1N4148
D102	DID04V70W5**9	4.7V 0.5W
D104	DIDIN4002***2	1N4002
D601-D603	DIDIN4148***8	1N4148
D701-D703	DIDIN4148***8	1N4148
D704	DID022V0W5**7	22V 0.5W

-CARBON RESISTORS-

All resistors are rated + 5% tolerance and 1/4W

R003, R004	CBR03K30W4TJ4	3K3 ohm
R101, R102	CBR015K0W4TJ0	15K ohm
R103	CBR047K0W4TJ6	47K ohm
R104	CBR220R0W4TJ1	220 ohm
R105	CBR01M20W4TJ9	1M2 ohm
R201, R301	CBR022R0W4TJ8	22 ohm

REF. NO.	PARTS NO.	DESCRIPTION
R202, R302	CBR056K0W4TJ7	56K ohm
R206, R306	CBR001K0W4TJ7	1K ohm
R209, R309	CBR001K0W4TJ7	1K ohm
R210, R310	CBR068K0W4TJ1	68K ohm
R211, R311	CBR100R0W4TJ4	100 ohm
R213, R313	CBR056R0W4TJ2	56 ohm
R214, R314	CBR150R0W4TJ1	150 ohm
R601, R701	CBR02K20W4TJ5	2K2 ohm
R602, R702	CBR047K0W4TJ6	47K ohm
R603, R703	CBR033K0W4TJ2	33K ohm
R604, R704	CBR01K80W4TJ1	1K8 ohm
R605, R705	CBR03K30W4TJ4	3K3 ohm
R606, R706	CBR03K30W4TJ4	3K3 ohm
R608, R708	CBR150R0W4TJ1	150 ohm
R609, R709	CBR010K0W4TJ8	10K ohm
R610, R710	CBR150R0W4TJ1	150 ohm
R611, R711	CBR03K90W4TJ6	3K9 ohm
R612, R712	CBR220R0W4TJ1	220 ohm
R613, R713	CBR047K0W4TJ6	47K ohm
R614, R714	CBR001K0W4TJ7	1K ohm
R616, R716	CBR010R0W4TJ3	10 ohm
R617, R717	CBR010R0W4TJ3	10 ohm
R620, R720	CBR04K70W4TJ4	4K7 ohm
R622, R722	CBR022K0W4TJ2	22K ohm
R723	CBR03K30W4TJ4	3K3 ohm
R624, R724	CBR150R0W4TJ1	150 ohm
R801-R806	CBR001K0W4TJ7	1K ohm
R807, R808	CBR04K70W4TJ4	4K7 ohm
R809, R810	CBR001K0W4TJ7	1K ohm
R815, R816	CBR470R0W4TJ1	470 ohm
R817-R821	CBR068K0W4TJ1	68K ohm

All resistors are rated \pm 5% tolerance and 1/4W F Tape

R607, R702	CBR010R0W4FJ3	10 ohm
R811, R812	CBR04K70W4FJ4	4K7 ohm
R813, R814	CBR068K0W4FJ1	68K ohm

All resistors are rated \pm 5% tolerance and 1/2W

R005, R006	CBR010K0W2TJ6	10K ohm
R008	CBR01K50W2TJ9	1K5 ohm
	CBR001K0W2TJ5	1K ohm
R106	CBR001K0W2TJ1	1K ohm

All resistors are rated \pm 5% tolerance and 1/3W

R615, R715	CBR330R0W3TJ2	330 ohm
------------	---------------	---------

-ETAL FILM RESISTORS-

All resistors are rated \pm 5% tolerance and 1/4W

R203, R303	PMR03K30W4TG5	3K3 ohm
------------	---------------	---------

REF. NO.	PARTS NO.	DESCRIPTION
R204, R304	PMR01K50W4TG1	1K5 ohm
R205, R305	PMR01K50W4TG1	1K5 ohm
R207, R307	PMR033K0W4TG3	33K ohm
R208, R308	PMR330K0W4TG9	330K ohm

All resistors are rate \pm 5% tolerance and 1W

R001, R002	MTR001K01WTJ8	1K ohm
R107	MTR470R01WTJ2	470 ohm
R621, R721	MTR010R01WTJ4	10 ohm

-CEMENT-FILLED FIXED RESISTORS-

All resistors are rate \pm 5% tolerance and 5W

R618, R718	CMR0R3305WTE9	0.33 ohm
R619, R719	CMR0R3305WTE9	0.33 ohm

-CAPCITORS-

C001	CRC0P0101KRZ1	Ceramic	0.01u	500V
C003, C004	ELC06K8050R35	Elec.	6800u	50V
C005, C006	ELC220U025R38	Elec.	220u	25V
C007-C010	ELC220U016R37	Elec.	220u	16V
C011	ELC100U050R31	Elec.	100u	50V
C012	ELC04U7050R54	Elec.	4.7u	50V KULR
C101	ELC220U016R01	Elec.	220u	16V NP
C102	ELC033U010R38	Elec.	33u	10V
C103	PECU022050RK3	Mylar	0.022K	
C201, C301	CRC0100050RK5	Ceramic	100P	50V
C202, C302	CRC0330050RK1	Ceramic	330P	50V
C203, C303	ELC470U016R37	Elec.	470u	16V
C204, C304	PEC2000050RJ5	Mylar	0.002u	50V
C205, C305	PECU022500RK3	Mylar	0.0068u	50V
C206, C306	ELC0U33050R55	Elec.	0.33u	50V
C208, C308	ELC047U016R37	Elec.	47u	16V
C601, C701	ELC04U7025R35	Elec.	4.7u	25V
C602, C702	CRC0200500RK5	Ceramic	200P	50V
C604, C704	ELC220U016R37	Elec.	220u	16V
C605, C705	CRC0022500RK0	Ceramic	22P	500V
C606, C706	CRC0015500RK7	Ceramic	15P	500V
C607, C707	CRC0100050RK5	Ceramic	100P	50V
C608, C708	PEC00U1050RK3	Ceramic	0.1u	50V
C609, C709	CRC0100050RK5	Ceramic	100P	50V
C610, C710	PECU022050RK3	Mylar	0.022u	50V
C611, C711	ELC0U47050R09	Elec.	0.47u	50V NP
C612, C712	CRC0010500RK9	Ceramic	10P	500V
C713	ELC100U025R30	Elec.	100P	25V
C614, C714	CRC0330500RK4	Ceramic	330P	500V
C801-C804	CRC0100050RK4	Ceramic	100P	50V
C805, C806	ELC047U016R37	Elec.	47u	16V
C807-C810	CRC0100050RK5	Ceramic	100P	50V

REF. NO. PARTS NO. DESCRIPTION

-VARIABLE RESISTORS-

TVR001,TVR701 TVR001K063HM1 60H 1K ohm

-COILS-

L601,L701 CIL1851000186 18 1/2T

-MISCELLANEOUS-

RY-101 RCKYK000904P2 4P RCA Jack
 CHAPC02023**5 2P RCA Jack
 CNT**514311P1 Wafer Connector 11P
 RLY24V5A2P2C1 Relay
 SLSESA26142*4 Slide Switch
 SDY43SQ1119*8 Pin 1x1x9
 FUHFH0003***1 Fuse Holder
 RAPH*0043***3 Heat Sink

TONE AMP.PCB ASSY T-A110(A2)

REF. NO. PARTS NO. DESCRIPTION

PCBT*0A110A24 TONE AMP PCB ASSY
 PCBT*0A110A24 TONE AMP PCB

-IC'S-

IC501 ICCNJ02043D*2 NJM2043D
 IC502 ICCNJ04558DD6 NJM4558DD

-CARBON RESISTORS-

All resistors are rated $\pm 5\%$ tolerance and 1/4W

R401,R501 CBR001K0W4TJ7 1K ohm
 R402,R502 CBR100K0W4TJ9 100K ohm
 R403 CBR010K0W4FJ8 10K ohm F Type
 R404 CBR082K0W4FJ5 82K ohm F Type
 R405,R505 CBR012K0W4TJ7 12K ohm
 R406,R506 CBR010K0W4TJ8 10K ohm
 R407,R507 CBR012K0W4TJ7 12K ohm
 R408,R508 CBR010K0W4TJ8 10K ohm
 R409,R509 CBR04K70W4TJ4 4K7 ohm
 R411,R511 CBR03K90W4TJ6 3K9 ohm
 R412,R512 CBR220K0W4TJ6 220K ohm
 R413,R513 CBR018K0W4TJ4 18K ohm
 R415,R515 CBR03K30W4TJ4 3K3 ohm
 R503 CBR010K0W4TJ8 10K ohm
 R504 CBR082K0W4TJ5 82K ohm

REF. NO. PARTS NO. DESCRIPTION

-CAPCITORS-

C401,C501 ELC04U7025R35 Elec. 4.7u 25V
 C402,C502 ELC100U010R34 Elec. 100u 10V
 C403,C503 CRC0010050RK4 Ceramic 10P 50V
 C404,C504 ELC04U7025R35 Elec. 4.7u 25V
 C405,C505 PECU033050RJ2 Mylar 0.033u 50V
 C406,C506 PECU033050RJ2 Mylar 0.033u 50V
 C407,C507 PEC3300050RJ8 Mylar 0.0033u 50V
 C408,C508 PEC3300050RJ8 Mylar 0.0033u 50V
 C409,C509 PEC4700050RJ6 Mylar 0.005u 50V
 C410,C510 ELC04U7025R35 Elec. 4.7u 25V
 C411,C511 PEC6800050RJ4 Mylar 0.0068u 50V
 C412,C512 PEC0U01050RJ8 Mylar 0.01u 50V
 C413,C513 PECU033050RJ2 Mylar 0.033u 50V
 C514,C515 ELC047U016R37 Elec. 47u 16V

-VARIABLE RESISTORS-

VR503,VR504 RVR100K25BE27 100KBx2
 VR505 RVR100K25AT26 100KAx2

-MISCELLANEOUS-

PHSSUF12AE157 Push Switch
 PRL11002403P4 Connector 3Px110 m/m

SWITCH PCB ASSY S-A117(C2)

REF. NO. PARTS NO. DESCRIPTION

PCBS*0A117C24 SWITCH PCB ASSY
 PCBS*0A117C24 SWITCH PCB

-CARBON RESISTORS-

All resistors are rated $\pm 5\%$ tolerance and 1/4W

R212,R312 CBR100R0W4TJ4 100 ohm

-MISCELLANEOUS-

C207,C307 PEC0U01050RJ8 Mylar 0.01u 50V
 PRL10002405P9 Connector 5Px110
 PRL17002403P7 Connector 3Px170
 PCBS*0A117C24 Slide Switch

TONE AMP PCB ASSY T-A110(B2)

REF. NO.	PARTS NO.	DESCRIPTION
	PCBT*0A110B24	TONE AMP PCB ASSY
	PCBT*0A110B24	TONE AMP PCB

-VARIABLE RESISTIORS-

VR501	RVR250K25MC20	MN250Kx2
VR502	RVR100K18AZ11	250KA

SWITCH PCB ASSY S-A117(B2)

REF. NO.	PARTS NO.	DESCRIPTION
	PCBS*0A117B24	SWIITCH PCB ASSY
	PCBS*0A117B24	SWITCH PCB

-MTEAL FILMM RESISTORS-

R108,R109	MTR330R01WTJ4	330 ohm 1W
	PHSSUF21CE115	Push Switch

FUNCTION SWITCH PCB ASSY S-A117(A2)

REF. NO.	PARTS NO.	DESCRIPTION
	PCBS*0A117A24	FUNCTION SWITCH PCB ASSY
	PCBS*0A117A24	FUNCTION SWITCH PCB

-CARBON RESISTORS-

All resistors are rated $\pm 5\%$ tolerance and 1/4W

R901	CBR010K0W4TJ8	10K ohm
R902	CBR047R0W4TJ8	47 ohm

-MISCELLANEOUS-

	PHSSUF51AE185	Psuh Switch
	CNT**549408P7	Wafer Connector 8P
	PRL17002405P7	Connector 5Px130
	PRL17002605P7	Connector 6Px170
	SDY43SO1119*8	Pin 1x1x9

FUNCTION LED PCB ASSY L-A113(A2)

REF. NO.	PARTS NO.	DESCRIPTION
	PCBL*0A113A26	FUNCTION LED PCB ASSY
	PCBL*0A113A26	FUNCTION LED PCB
D-901-D906	LED050020GS*7	LED 2x5 Green
	PRL11002403P4	Connector 3Px110
	PRL10002405P9	Connector 5Px110
	GSKKB0196B**9	Washer

POWER LED PCB ASSY L-A113(B2)

REF. NO.	PARTS NO.	DESCRIPTION
	PCBL*0A113B26	POWER LED PCB ASSY
	PCBL*0A113B26	POWER LED PCB

-MISCELLANEOUS-

	LED050020RS*7	LED 2x5 Red
	GSKKB0194B*5*	Washer
	SCECT2606YC*4	Screw CRTS 2.6x6

POWER SWITCH PCB ASSY

REF. NO.	PARTS NO.	DESCRIPTION
		POWER SWITCH PCB ASSY
		POWER SWITCH PCB

-MISCELLANEOUS-

	CRC0P0101KRZ1	Ceramic 0.01u 1000V
	PWSES82131*1	Power Switch
	SCECT2606YC*4	Screw CRTS 2.6x6

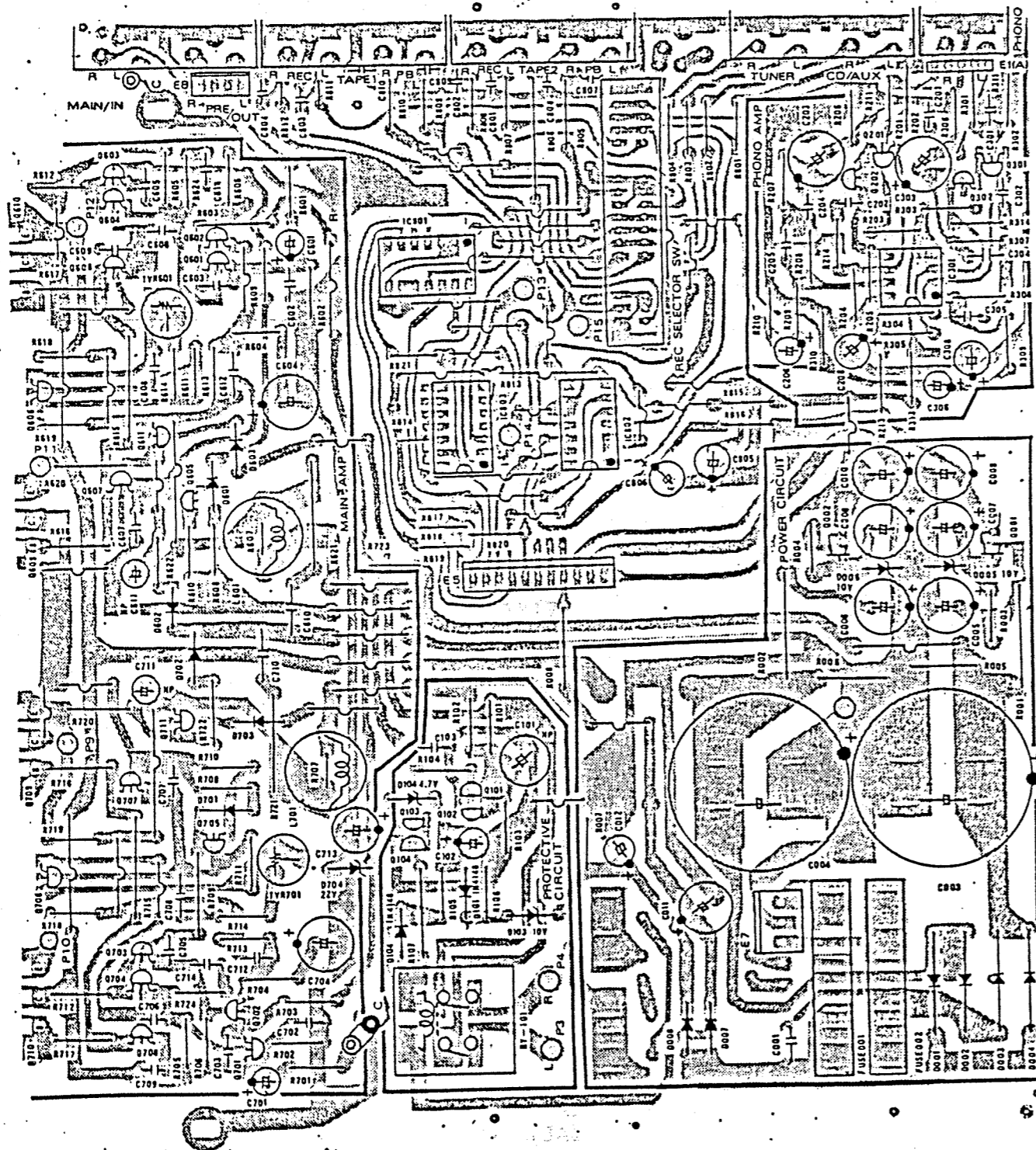

Specifications

X55

Power Output * 55 watts per channel minimum RMS, both channels driven at 8 ohms from 20 Hz to 20,000 Hz with no more than 0.05 % total harmonic distortion
 2 Channels Driven into 8 ohms at 1 kHz 145 W + 145 W
 Dynamic Power Output into 4 ohms 110 W + 110 W
 Total Harmonic Distortion (20 Hz to 20,000 Hz) AUX input to SPEAKER output 0.05 % at rated power into 8 ohms
 Damping Factor 50, at 50 Hz
 Transient Response Rise Time 1.2 μ s
 Frequency Response 5 Hz to 40 kHz 0 -3 dB
 Speaker Impedance Accept 8 ohms to 16 ohms
 Input Sensitivity/Impedance
 Phono MM 2.7 mV/47 k ohms
 Phono MC 0.24 mV/95 ohms
 Tuner, CD/AUX, Tape 1/2 120 mV/47 k ohms
 Signal-to-Noise Ratio (IEC-A)
 Phono MM 75 dB for 2.7 mV input
 Phono MC 65 dB for 0.24 mV input
 Tuner, CD/AUX, Tape 1/2 94 dB
 Maximum Input Level for Phono
 MM 100 mV (RMS), T.H.D. 0.05 % at 1 kHz
 MC 4 mV (RMS), T.H.D. 0.05 % at 1 kHz
 Output Level/Impedance
 Tape Rec 1/2 90 mV/100 k ohms
 Pre Out 1000 mV/47 k ohms
 Frequency Response for Phono RIAA standard curve ± 0.5 dB (20 Hz to 20,000 Hz)
 Tone Control
 Bass ± 12 dB at 100 Hz
 Treble ± 12 dB at 10,000 Hz
 Loudness Control
 -2.5/-6/-9 dB at 100 Hz/10 kHz/1 kHz
 Filter
 High 10 kHz, -6 dB

[General]

Power Requirements 110/220V AC, 50/60 Hz, 240 W (General Export)
 120 V AC, 60 Hz, 220 W (USA/Canada)
 220 V AC, 50 Hz, 240 W (Europe)
 240 V AC, 50 Hz, 240 W (UK/Australia)
 Dimensions (W x H x D) 435 x 80 x 295 mm (17-1/8" x 3-3/16" x 11-5/8")
 Weight (net) 7.6 kg (16.72 lbs.)

Caractéristiques techniques

Technische Daten

Puissance de sortie * 55 W minimum RMS par canal, les deux canaux sous 8 ohms de 20 Hz à 20.000 Hz avec pas plus de 0,05 % de distorsion harmonique totale.
 Les deux canaux sous 8 ohms à 1 kHz 145 W + 145 W
 Puissance dynamique sous 4 ohms 110 W + 110 W
 Distorsion harmonique totale (20 Hz à 20.000 Hz) De l'entrée AUX à la sortie SPEAKER 0,05 % à puissance nominale sous 8 ohms
 Coefficient d'amortissement 50, à 50 Hz
 Réponse transitoire Temps de montée 1,2 μ s
 Réponse en fréquence 5 Hz à 40 kHz 0 -3 dB
 Impédance des haut-parleurs 8 à 16 ohms
 Sensibilité d'entrée/Impédance
 Phono MM 2,7 mV/47 kohms
 Phono MC 0,24 mV/95 ohms
 Tuner, CD/AUX, Tape 1/2 120 mV/47 kohms
 Rapport signal/bruit (IEC-A)
 Phono MM 75 dB pour 2,7 mV en entrée
 Phono MC 65 dB pour 0,24 mV en entrée
 Tuner, CD/AUX, Tape 1/2 94 dB
 Niveau d'entrée maximal pour phono
 MM 100 mV (RMS), DHT 0,05 % à 1 kHz
 MC 4 mV (RMS), DHT 0,05 % à 1 kHz
 Niveau de sortie/impédance
 Tape Rec 1/2 90 mV/100 kohms
 Sortie préampli 1000 mV/47 kohms
 Réponse en fréquence pour phono Courbe standard RIAA $\pm 0,5$ dB (20 Hz à 20.000 Hz)
 Commande de tonalité
 Graves ± 10 dB à 100 Hz
 Aigus ± 12 dB à 10.000 Hz
 Commande de contour
 -2,5/-6/-9 dB à 100 Hz/10 kHz/1 kHz
 Filtre Haut 10 kHz, -6 dB

[Générales]

Alimentation 110/220 V CA, 50/60 Hz, 240 W (Exportation générale)
 120 V CA, 60 Hz, 220 W (Etats-Unis/Canada)
 220 V CA, 50 Hz, 240 W (Europe)
 240 V CA, 50 Hz, 240 W (Royaume-Uni/Australie)
 Dimensions (L x H x P) 435 x 80 x 295 mm
 Poids (net) 7,6 kg

Nennausgangsleistung * 55 Watt pro kanal min. eff., beide Kanäle an 8 Ohm von 20 Hz bis 20.000 Hz, bei max. 0,05 % Klirrfaktor
 Beide Kanäle an 8 Ohm bei 1 kHz 145 W + 145 W
 Musikleistung an 4 Ohm 110 W + 110 W
 Klirrfaktor (20 Hz bis 20.000 Hz) AUX-Eingang zu Lautsprecherausgang 0,05 % bei Nennleistung an 8 Ohm
 Dämpfungsfaktor 50, bei 50 Hz
 Einschwigverhalten Anstiegszeit 1,2 μ s
 Frequenzgang 5 Hz bis 40 kHz 0 -3 dB
 Lautsprecherimpedanz 8 bis 16 Ohm
 Eingangsempfindlichkeit/-impedanz
 Phono MM 2,7 mV/47 kOhm
 Phono MC 0,24 mV/95 Ohm
 Tuner, CD/AUX, Tape 1/2 120 mV/47 kOhm
 Signal/Rauschabstand (IEC-A)
 Phono MM 75 dB für 2,7 mV Eingang
 Phono MC 65 dB für 0,24 mV Eingang
 Tuner, CD/AUX, Tape 1/2 94 dB
 Max. Phono-Eingangsepegel
 MM 100 mV (eff.), 0,05 % Klirrfaktor bei 1 kHz
 MC 4 mV (eff.), 0,05 % Klirrfaktor bei 1 kHz
 Ausgangsepegel/-impedanz
 Tape Rec 1/2 90 mV/100 kOhm
 Pre Out 1.000 mV/47 kOhm
 Frequenzgang für Phono RIAA-Standardkurve $\pm 0,5$ dB (20 Hz bis 20.000 Hz)
 Klangregelung
 Bass ± 12 dB bei 100 Hz
 Treble ± 12 dB bei 10.000 Hz
 Loudness-Regelung
 -2,5/-6/-9 dB bei 100 Hz/10 kHz/1 kHz
 Filter
 High 10 kHz, -6 dB

[Allgemein]

Spannungsversorgung 110/220 V Wechselstrom, 50/60 Hz, 240 W (Allgemeines Exportmodell)
 120 V Wechselstrom, 60 Hz, 220 W (USA/Kanada)
 220 V Wechselstrom, 50 Hz, 240 W (Europa)
 240 V Wechselstrom, 50 Hz, 240 W (Großbritannien/Australien)
 Abmessungen (B x H x T) 435 x 80 x 295 mm
 Gewicht (netto) 7,6 kg

• Measured pursuant to Federal Trade Commission's Trade Regulation rule on Power Output Claim for Amplifier in U.S.A.

• Mesure conforme à la réglementation de la commission fédérale du commerce (FTC) pour la définition de la puissance de sortie des amplificateurs aux Etats-Unis.

IEC

[Power Amplifier Section]

Rated Power Output
 8 ohms at 20 Hz to 20,000 Hz
 no more than 0.05 % THD (FTC)
 55 W + 55 W
 4 ohms at 63 Hz to 12,500 Hz
 no more than 0.7 % THD (IEC/NF)
 65 W + 65 W

Total Harmonic Distortion
 Rated Power Output into 8 ohms
 0.05 %

Frequency Response
 5 Hz - 40 kHz -3 dB

S/N Weighted: Rated Output Power (IEC-A)
 () = Unweighted at 50 mW (DIN)
 Phono MM 75 dB (71 dB)
 Phono MC 65 dB (55 dB)
 Tuner, CD/AUX, Tape 1/2 94 dB (82 dB)

Damping Factor at 8 ohms, 50 Hz 50

Transient Response
 Rise Time 1.2 μ s

Input Sensitivity/Impedance
 Phono MM 2.7 mV/47 k ohms
 Phono MC 0.24 mV/95 ohms
 Tuner, CD/AUX, Tape 1/2 120 mV/
 47 k ohms

Tone Control
 Bass 100 Hz, ± 12 dB
 Treble 10,000 Hz, ± 12 dB

Loudness Control (-30 dB) -2.5/-6/-9 dB
 at 100 Hz/10 kHz/1 kHz

Filter
 High 10 kHz, -6 dB

[General]
Power Consumption
 IEC 240 W
Dimensions (W x H x D) 435 x 80 x 295 mm
Weight (net) 7.6 kg

[Partie amplificateur de puissance]

Puissance de sortie nominale
 8 ohms de 20 Hz à 20.000 Hz
 pas plus de 0,05 % de DHT (FTC)
 55 W + 55 W
 4 ohms de 63 Hz à 12.500 Hz
 pas plus de 0,7 % de DHT (IEC/NF)
 65 W + 65 W

Distorsion harmonique totale
 Puissance de sortie nominale sous
 8 ohms 0,05 %

Réponse en fréquence 5 Hz - 40 kHz -3 dB

S/B pondéré: puissance de sortie nominale (IEC-A)
 () = Non pondéré à 50 mW (DIN)
 Phono MM 75 dB (71 dB)
 Phono MC 65 dB (55 dB)
 Tuner, CD/AUX, Tape 1/2 94 dB (82 dB)

Coefficient d'amortissement sous 8 ohms, 50 Hz 50

Réponse transitoire
 Temps de montée 1,2 μ s

Sensibilité d'entrée/Impédance
 Phono MM 2,7 mV/47 kohms
 Phono MC 0,24 mV/95 ohms
 Tuner, CD/AUX, Tape 1/2 120 mV/
 47 kohms

Commande de tonalité
 Graves 100 Hz, ± 12 dB
 Aigus 10.000 Hz, ± 12 dB

Commande de contour (-30 dB) -2,5/-6/-9 dB
 à 100 Hz/10 kHz/1 kHz

Filter
 Haut 10 kHz, -6 dB

[Générales]
Consommation (IEC) 240 W
Dimensions (L x H x P) 435 x 80 x 295 mm
Poids (net) 7,6 kg

[Leistungsverstärkerteil]

Nennausgangsleistung
 8 Ohm bei 20 Hz bis 20.000 Hz
 max. 0,05 % Klirrfaktor (FTC)
 55 W + 55 W
 4 Ohm bei 63 Hz bis 12.500 Hz
 max. 0,7 % Klirrfaktor (IEC/NF)
 65 W + 65 W

Klirrfaktor
 Gewichtete Ausgangsleistung an 8 Ohm
 0,05 %

Frequenzgang 5 Hz - 40 kHz 0/-3 dB
 Signal/Rauschabstand Gewicht: Nenn-
 Ausgangsleistung (IEC-A) = Ungewichte
 bei 50 mW (DIN)
 Phono MM 75 dB (71 dB)
 Phono MC 65 dB (55 dB)
 Tuner, CD/AUX, tape 1/2 94 dB (82 dB)

Dämpfungsfaktor bei 8 Ohm, 50 Hz 50
Anspruchverhalten
 Anstiegszeit 1,2 μ s

Eingangsempfindlichkeit/-impedanz
 Phono MM 2,7 mV/47 kOhm
 Phono MC 0,24 mV/95 Ohm
 Tuner, CD/AUX, Tape 1/2 120 mV/
 47 kOhm

Klangregelung
 Bass +/-12 dB bei 100 Hz
 Treble +/-12 dB bei 10.000 Hz

Loudness-Regelung (bei -30 dB)
 Lautstärkepegel -2,5/-6/-9 dB bei
 100 Hz/10 kHz/1 kHz

Filter
 High 10 kHz, -6 dB

[Allgemein]
Leistungsaufnahme 240 W
Abmessungen (B x H x T) 435 x 80 x 295 mm
Gewicht (netto) 7,6 kg

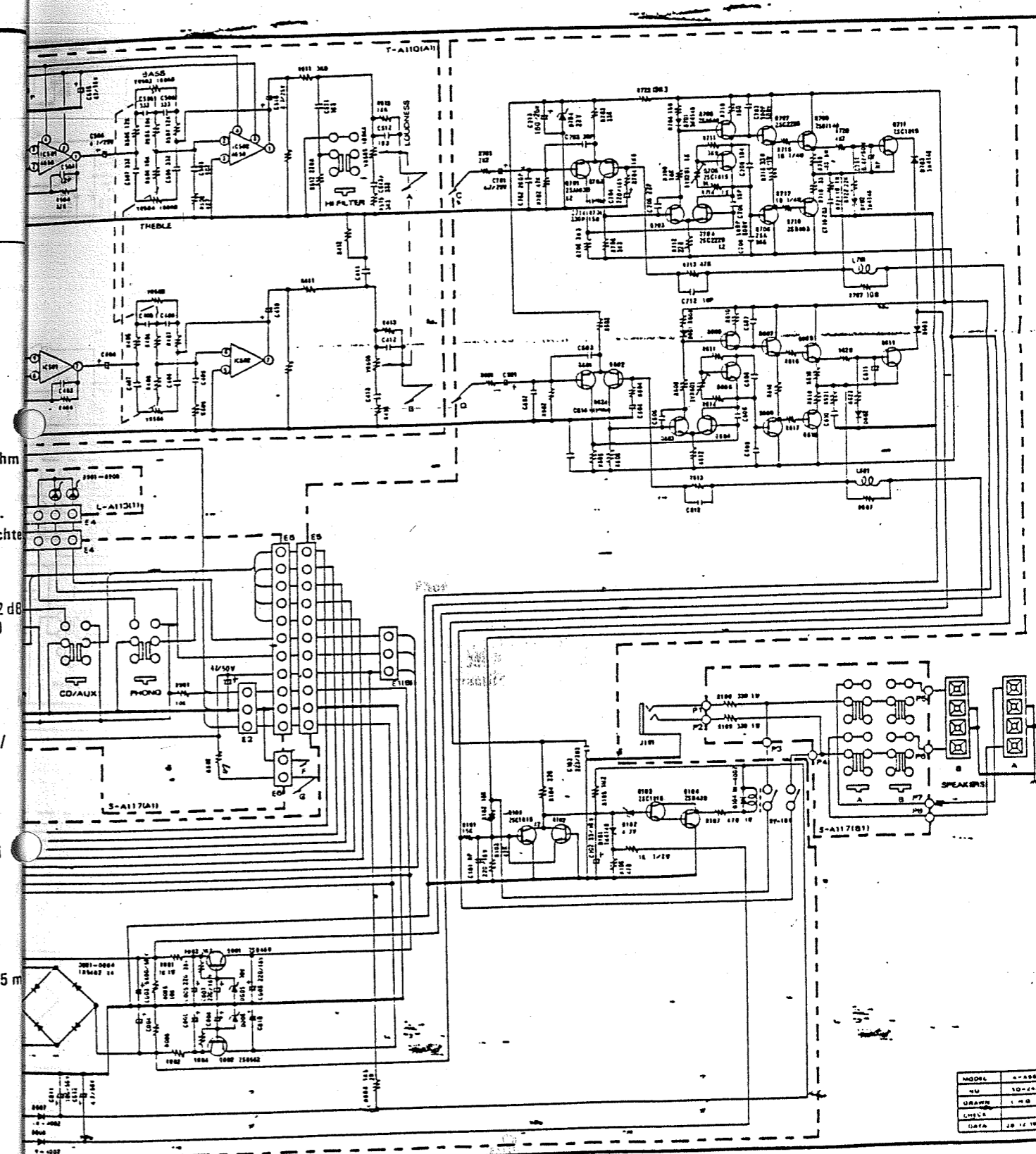

10VAC
 K/Australia
 W x H x D 435 x 80 x 295 mm
 W x H x D 435 x 80 x 295 mm
 W x H x D 435 x 80 x 295 mm

10VAC
 K/Australia
 W x H x D 435 x 80 x 295 mm
 W x H x D 435 x 80 x 295 mm
 W x H x D 435 x 80 x 295 mm

MODEL	A-400
NO	10-100
DRAWN	M.B.
CHECK	
DATE	28.11.1988

