

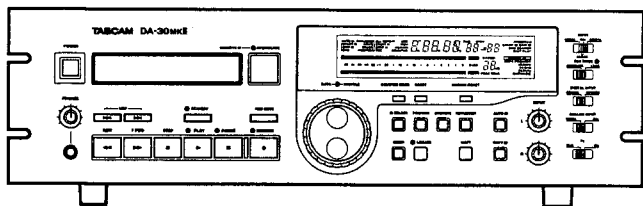

TEAC - 00291

# TASCAM

TEAC Professional Division



## SERVICE MANUAL

# DA-30MKII/DA-25

## Digital Audio Tape Deck

### NOTES

As regards the resistors and capacitors, refer to the circuit diagrams and the PCB ass'y drawings contained in this manual.

- PC boards shown viewed from parts side.
- Parts marked with \* require longer deliver time.
- $\Delta$  Parts marked with this sign are safety critical components. They must always be replaced with identical components – refer to the TEAC Parts List and ensure exact replacement.
- Parts not shown in the parts lists, or parts, though listed, having no parts numbers, are not general "ready-to-supply" parts.
- Parts of [ ] mark can be used only with the version designated.  
[J]: JAPAN [US/C]: U.S.A./CANADA [GE]: GENERAL EXPORT [E]: EUROPE [UK]: U.K. [A]: AUSTRALIA

### 注意

標準抵抗、コンデンサーは省略してあります。回路図および基板図を参照してください。

- プリント基板図は部品面が示されています。
- \*印の部品は納期が若干かかります。あらかじめご了承ください。
- $\Delta$ 印は安全規格重要部品です。交換するときは必ずティアップ指定の部品を使用してください。
- リストされていない部品は原則としてサービス供給部品として取扱っていません。
- 仕向け先  
[J]: JAPAN [US/C]: U.S.A./CANADA [GE]: GENERAL EXPORT [E]: EUROPE [UK]: U.K. [A]: AUSTRALIA

### INSTRUCTIONS FOR SERVICE PERSONNEL

BEFORE RETURNING APPLIANCE TO THE CUSTOMER, MAKE LEAKAGE - CURRENT OR RESISTANCE MEASUREMENTS TO DETERMINE THAT EXPOSED PARTS ARE ACCEPTABLY INSULATED FROM THE SUPPLY CIRCUIT.

# 1. SPECIFICATIONS

## 仕様

<b>Category :</b>	Rotary Head Digital Audio Tape Recorder
<b>Tape Speed :</b>	8.15 mm/sec. in STANDARD mode (play speed of 12.225 mm/sec. also supported) 4.075 mm/sec. in LONG mode
<b>Record Time :</b>	120 minutes in STANDARD/240 minutes in LONG (with 120-min. cassette)
<b>Head Drum Speed :</b>	2,000 rpm in STANDARD/1,000 rpm in LONG (during Record)
<b>Fast Winding :</b>	70 seconds (approx.) (with R-120 cassette)
<b>Error Correction :</b>	Octet (eightfold) correction
<b>Channel Number :</b>	2
<b>Quantization Bit :</b>	16 bit linear in STANDARD/12 bit non-linear in LONG
<b>Sampling Rate :</b>	48 kHz (in play/record, digital/analog)/44.1 kHz (in play/record, digital/analog)/ 32 kHz (in play/record, digital only in STANDARD, digital/analog in LONG)
<b>Frequency Response :</b>	20-20,000 Hz $\pm$ 0.5 dB in STANDARD/20-14,500 Hz $\pm$ 0.5 dB in LONG
<b>Signal-to-Noise Ratio :</b>	Better than 92 dB
<b>Dynamic Range :</b>	Better than 93 dB
<b>Total Harmonic Distortion :</b>	Less than 0.004 % (1 kHz, Fs on, in STANDARD) Less than 0.07 % (1 kHz, Fs on, in LONG)
<b>Channel Separation :</b>	Better than 85 dB (at 1 kHz)
<b>Wow and Flutter :</b>	Unmeasurable (less than $\pm$ 0.001 %)
<b>Input</b>	
<b>Analog</b>	
<b>BALANCED [DA-30MKII] :</b>	XLR type connector (XLR-3-31) $\times$ 2
<b>Nominal Input Level :</b>	+4 dBm
<b>Input Impedance :</b>	10 ohms balanced
<b>UNBALANCED :</b>	RCA jack $\times$ 2
<b>Nominal Input Level :</b>	-10 dBV
<b>Input Impedance :</b>	50 ohms unbalanced
<b>Digital</b>	
<b>AES/EBU Port [DA-30MKII] :</b>	XLR type connector (XLR-3-31), IEC 958 TYPE I (AES/EBU)
<b>Coaxial Port :</b>	RCA jack, IEC 958 TYPE II (SPDIF)
<b>Output</b>	
<b>Analog</b>	
<b>BALANCED [DA-30MKII] :</b>	XLR type connector (XLR-3-32) $\times$ 2
<b>Maximum Output Level :</b>	20 dBm
<b>Nominal Output Level :</b>	+4 dBm
<b>Output Impedance :</b>	75 ohms balanced
<b>UNBALANCED :</b>	RCA jack $\times$ 2
<b>Maximum Output Level :</b>	2.0 volts
<b>Nominal Output Level :</b>	-10 dBV
<b>Output Impedance :</b>	430 ohms unbalanced
<b>PHONES :</b>	1/4" jack $\times$ 1
<b>Output Level :</b>	100 mW + 100 mW (8-ohm load)
<b>Digital</b>	
<b>AES/EBU Port [DA-30MKII] :</b>	XLR type connector (XLR-3-32), IEC 958 TYPE I (AES/EBU)
<b>Coaxial Port :</b>	RCA jack, IEC 958 TYPE II (SPDIF)
<b>Remote Connection :</b>	Mini jack
<b>External Control I/O Port :</b>	D-sub 15 pin (female)
<b>Power Requirements :</b>	
<b>JAPAN :</b>	100 V AC, 50-60 Hz
<b>USA/CANADA :</b>	120 V AC, 60 Hz
<b>U.K./AUSTRALIA :</b>	240 V AC, 50 Hz
<b>EUROPE :</b>	230 V AC, 50 Hz
<b>General Export Model :</b>	100/120/230/240 V AC, 50-60 Hz
<b>Consumption :</b>	28 Watts (DA-30MK II) / 25 Watts (DA-25)
<b>Dimensions (WxHxD) :</b>	482 $\times$ 150.5 $\times$ 353 mm (19" $\times$ 6.3/32" $\times$ 13.7/8")
<b>Weight :</b>	About 8.5 kg (18-12/16 lbs) (DA-30MK II) About 8.3 kg (18-5/16 lbs) (DA-25)

## 2. MOUNTING OF THE HOUR METER

アワー・メータの取付

### How to Mount Hour Meter

### 取付方法

Solder each of the following parts to its designated location on the DIGITAL SERVO PCB.

下記の各部品をDIGITAL SERVO PCBの該当するシルク個所に半田付けする。

Ref. No.	Parts No.	Description	部番	品番	品名・定格
M501	5347002900	FC Timer TM3L	M501	5347002900	FCタイマー TM3L
R501	5241462720	Metal Film Resistor 75 k $\Omega$	R501	5241462720	金属皮膜抵抗 75 k $\Omega$
R502	5241463820	Metal Film Resistor 220 k $\Omega$	R502	5241463820	金属皮膜抵抗 220 k $\Omega$
R503	5241460820	Metal Film Resistor 12 k $\Omega$	R503	5241460820	金属皮膜抵抗 12 k $\Omega$

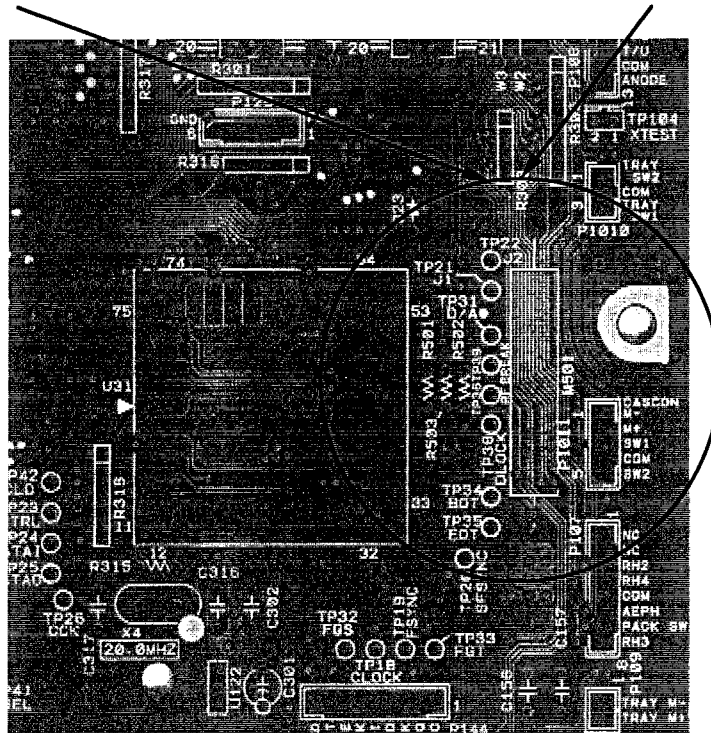

Fig. 2-1

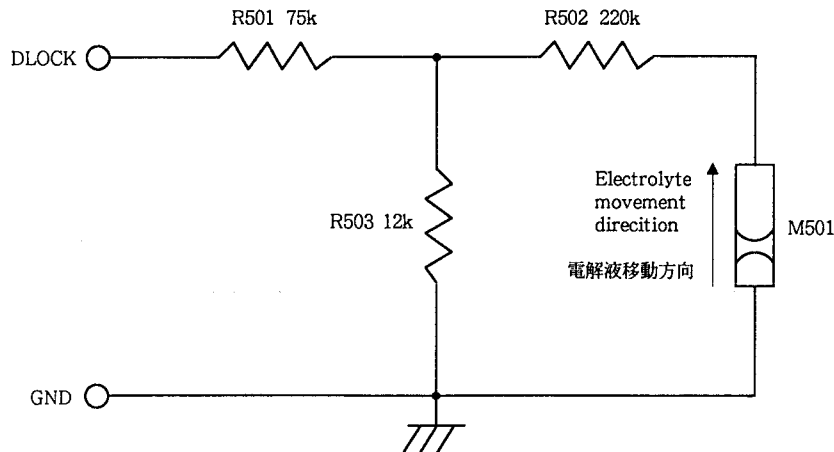

Fig. 2-2

## 3. REMOVAL OF COMPONENTS

### 各部品の外し方

This section primarily shows the disassembly procedure ; to reassemble, reverse the procedure.

#### 3-1. Cautions in handling the mechanism ass'y

1. When lifting the mechanism ass'y, do NOT hold both edges with one hand ; hold the right and left edges of the chassis with two hands.
2. Do NOT touch the head drum.
3. After removing the mechanism ass'y, always place it with its right side up.  
If it must be placed upside down for any reason, place a protective sheet such as bubble packing, etc. underneath to protect the exterior of the cassette holder.
4. Do NOT pull or bend leads strongly.
5. Do NOT lift the mechanism ass'y by the leads.
6. Do NOT touch the guide roller with your bare hands.  
To clean dirt or dust off the roller, wipe it gently with a cotton swab moistened with alcohol.
7. Do NOT touch the portions of the posts which come into contact with the tape.
8. Do NOT touch the rubber portions of the pinch roller or belt and the felt portion of the tension band, etc. with greasy fingers.
9. Do NOT touch the pulley over which the belt is hooked with greasy fingers, etc.
10. When disassembling the mechanism ass'y, pay attention to the following :
  - (1) The counter torque when screw-locking compound is not applied is maintained at 1 kg·cm or more ; therefore, be careful.
  - (2) If a screw secured with screw-locking compound is removed, reapply the compound after reinstalling it. Tightening screws with too much torque may strip the screw threads ; be careful.
11. When removing the coil spring, take care so that the hook is NOT deformed.
12. When the head becomes dirty, use a cleaning tape.
13. When reassembling, take care NOT to let leads or cables be pinched by the chassis, etc.
14. When reinstalling, pay attention to the following :
  - (1) Each of the unthreaded screws should be tightened with its own torque which is designated in the corresponding exploded view.
  - (2) Never use the removed E-rings and washers again.
15. Do NOT touch the surface of the drum with which the tape comes into contact.
16. When lifting the drum, hold both sides of its base.
17. When placing the drum on a work bench, place it on a soft mat so that no load or impact is applied to the rotor of the drum and motor.
18. Do NOT lift the drum by its leads.
19. Do NOT perform any soldering near the drum.
20. Do NOT apply an external force to the upper drum.

この部では外し方を主に記述しますが、組立は分解の逆の手順で行なって下さい。

#### 3-1. メカニズム Ass'y 取扱上の注意

##### 1. メカニズム

- 1). メカニズム Ass'y を掴むときは、片手で両側を強く掴まないこと。シャーシの左右の端を両手で掴むこと。
- 2). シリンダーのドラム部には、手を触れないこと。
- 3). メカニズム Ass'y を置くときは、衝撃を与えないように置くこと。また、メカニズム Ass'y は通常方向に置くこととし、やむをえず逆さまに置く場合は、下にエア・パッキン等保護材を敷き、カセット・ホルダーの外装部品を保護すること。
- 4). リード線を強く引っ張ったり曲げたりしないこと。
- 5). リード線を持って、メカニズム Ass'y を持ち上げないこと。
- 6). ガイド・ローラーのローラーには、手で触らないこと。  
汚れを拭くときは、アルコールを綿棒に浸して軽く拭くこと。
- 7). 各ポストのテープ走行面には、手で触らないこと。  
ピンセットやドライバー等で傷を付けないこと。また、磁化されたピンセット、ドライバーで触らないこと。
- 8). ピンチローラー、ベルト等のゴム部、テンション・バンド等のフェルト部に油のついた手で触らないこと。
- 9). ベルトのかかるプーリー等にグリスの付いた手で触らないこと。
- 10). メカニズム Ass'y の分解のときは、次の点に注意すること。
  - ・ネジ・ロックの付いていない戻しトルクは、1kg·cm 以上で管理しているので注意が必要です。
  - ・ネジ・ロックが付いているネジを外した場合はネジ・ロックをすること。強く締めすぎるとネジバカになるので注意が必要です。
- 11). コイル・スプリングを外すときは、フックの変形に注意をすること。
- 12). ヘッドが汚れたときは、クリーニング・テープを使用すること。
- 13). 組立の際、線材をシャーシ等に挟み込むことのないように注意すること。
- 14). 組み立てのときは、次の点に注意すること。
  - ・外した各ネジは分解図中に示す締め付けトルクで締めること。
  - ・一度外したEリング、ワッシャは再び使用しないこと。

##### 2. シリンダー

- 1). シリンダーのテープ走行面には、手を触れないこと。
- 2). シリンダーを掴むときは、シリンダー・ベースの両端を持つこと。
- 3). シリンダーを置く場合は、ドラム及びモーターのローターに荷重、衝撃を与えないように軟らかい物の上に置くこと。
- 4). リード線を持ってシリンダーを持ち上げないこと。
- 5). シリンダーの近くで半田付けをしないこと。
- 6). 上ドラムに外力を加えないこと。

## 3-2. Disassembly of the Main Block (Fig. 3-1)

## 3-2. メイン・ブロックの分解 (Fig. 3-1)

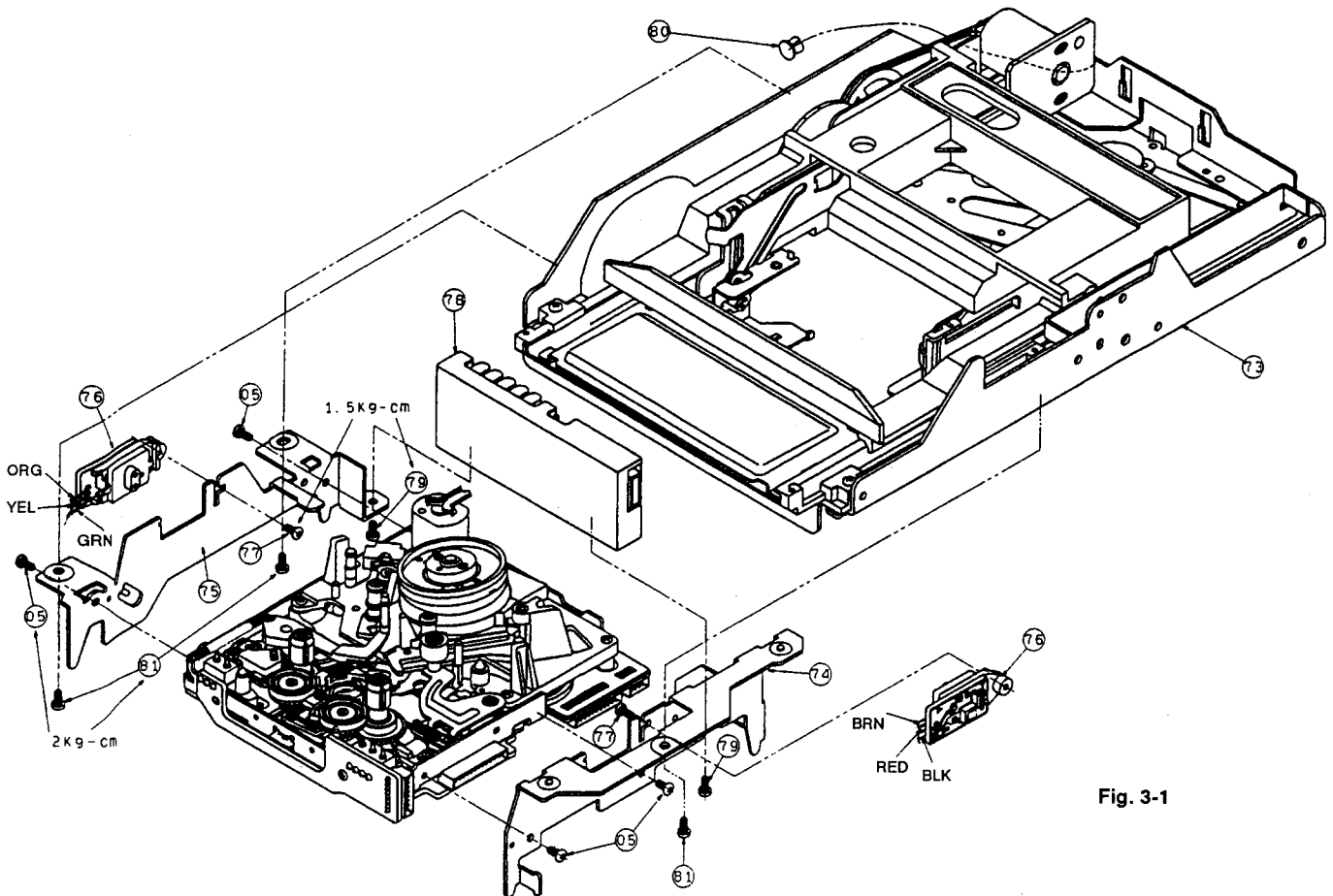

Fig. 3-1

### 1. Cassette Holder Block, Push Rivet

- 1) Unscrew the three (81) screws, then remove the (73) Cassette Holder Block.
- 2) Remove the (80) Push Rivet from the Cassette Holder Block.

**Note:** • Be careful NOT to break the cables.

### 2. RF Amp Block

- 1) Disconnect the Connector (RF output cables).
- 2) Unscrew the two (79) screws, then remove the (78) RF Amp Block.

**Note:** • When disconnecting the connectors, be careful NOT to put stress on the leads.

### 3. Sensor Block, Side Plate (R), Side Plate (L)

- 1) Cut the wire restraint bands.
- 2) Unscrew the four (5) screws, then remove the (74) Side Plate (R), (75) Side Plate (L). Unscrew the two (77) screws from both of the Side Plates (L, R), remove the hook of the Side Plate (L), then detach the (76) Sensor Block.

**Notes:** • Be careful NOT to break the cables.

- Since the (77) screw is a self-tapping screw, pay attention to the removal and tightening torque.

### 1. Cassette Holder Block, Push Rivet

- 1) (81) ネジ 3本を外し、(73) Cassette Holder Blockを外す。
- 2) Cassette Holder Blockより、(80) Push Rivetを外す。  
注意・線材の断線に注意をすること。

### 2. RF Amp Block

- 1) コネクタ (RF 出線) を外す。
- 2) (79) ネジ 2本を外し、(78) RF Amp Blockを外す。  
注意・コネクタを外す際の線材へのストレスに注意をすること。

### 3. Sensor Block, Side Plate (R), Side Plate (L)

- 1) a部結束バンドを切る。
- 2) (5)ネジ 4本を外し、(74) Side Plate (R), (75) Side Plate (L)を外す。Side Plate (L, R)の両方より (77) ネジ2本を外し、Side Plate (L)のフックを外し、(76) Sensor Blockを外す。  
注意・線材の断線に注意をすること。  
• (77) ネジはタッピング・ネジなので、取り外し、締付力には注意をすること。

## 3-3. Disassembly of the Base Mechanism Unit -1 (Fig. 3-2)

## 3-3. ベース・メカ・ユニットの分解 -1 (Fig. 3-2)

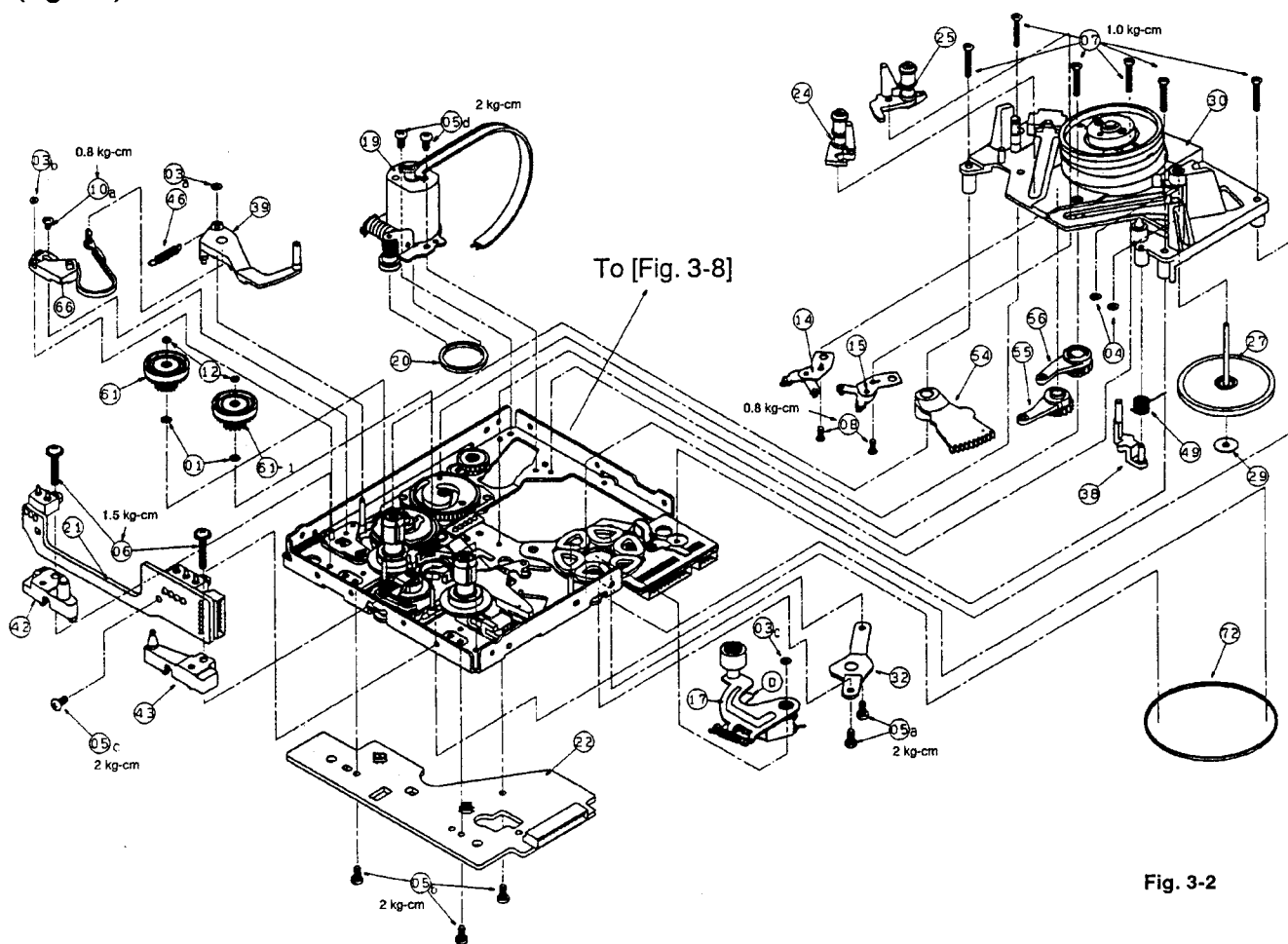

Fig. 3-2

### 1. Capstan Bracket, Wheel Shaft Retainer, Capstan Frange, Capstan Belt

- 1) Unscrew the two ⑤a screws, then remove the ③② Capstan Bracket.
- 2) Remove the ②⑨ Capstan Frange from the ②⑦ Rotor Block, then detach the ⑦② Capstan Belt.

**Notes :**

- Be careful NOT to scratch the Cylinder.
- When removing the Capstan Frange, be careful NOT to widen the inner diameter of it.
- When removing the Capstan Belt, be careful NOT to lengthen the Belt.
- When the ②⑦ Rotor Block is not replaced, the ⑦① Wheel Shaft Retainer should not be removed. (Refer to Fig. 3-3 for the assembling dimensions)

### 2. Sensor Block

- 1) Desolder nine soldered portions (7 + 2) (⑦⑩ 5-conductor J cable plus ①⑨-01 2-conductor J cable plus ⑥⑨ lead wires).
- 2) Unscrew the three ⑤b screws, then remove the ②② Sensor Block.

**Note :** • When soldering, pay attention to the direction of the ⑦⑩, and ①⑨-01 J cables.

### 1. Capstan Bracket, Wheel軸受け, Capstan Frange, Capstan Belt

- 1) ⑤a ネジ 2本を外し、③② Capstan Bracketを外す。
- 2) ②⑦ Rotor Blockより、②⑨ Capstan Frangeを外し、⑦② Capstan Beltを外す。

**注意** ・ シリンダに傷などをつけないようにすること。  
 ・ Capstan Frangeを外す時に内径をひろげないようにすること  
 ・ Capstan Beltを外す時にBeltを延ばさないようにすること。  
 ・ ⑦① Wheel軸受けは、②⑦ Rotor Blockを交換しない時は外さないこと。(組み立て寸法はFig. 3-3を参照のこと。)

### 2. Sensor Block

- 1) 半田付け9ヶ所(7+2)を外す。  
 (⑦⑩ 5芯J線 + ①⑨-01 2芯J線 + ⑥⑨ リード線)
- 2) ⑤b ネジ 3本を外し、②② Sensor Blockを外す。

**注意** ・ 半田付けの時、⑦⑩、①⑨-01 J線の向きに注意をすること。

3. Sensor Block, ID Spacer (L), ID Spacer (R)
  - 1) Unscrew the ⑤c screw.
  - 2) Unscrew the two ⑥ screws, then remove the ⑳ Sensor Block, ㉔ ID Spacer (L), and ㉕ ID Spacer (R).

**Note** : • When reinstalling, be careful NOT to tighten the ⑥ screw slantwise (because the switch is mounted obliquely).

4. ⑥① TU Assy, ⑥①-1 TU Assy
  - 1) Remove the two ⑫ washers, detach both of the TU assemblies, then take off the two ① washers. Refer to Fig. 3-4.

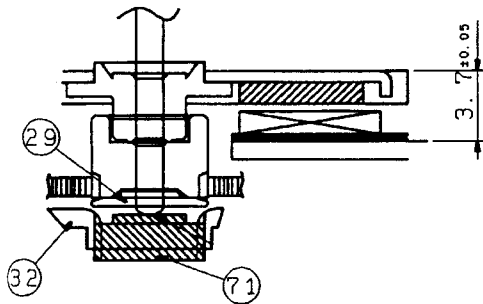

Adjust (71) so that the clearance between the chassis and the rotor becomes 3.7 mm, then apply the screw-locking compound to them.

シャーシとロータのギャップが3.7になる様に (71) で調整しネジ・ロックのこと。

Fig. 3-3

5. BT Arm, BT Spring, BT Band Assy
  - 1) Remove the ③a washer, then disengage the ④⑥ BT Spring.
  - 2) Remove the hook of the ⑥⑥ BT Band Assy from the ③⑨ BT Arm, then detach the BT Arm.
  - 3) Remove the ③b washer, unscrew the ⑩a screw, then detach the BT Band Assy.

**Notes** : • Pay attention NOT to deform the band of the BT Band Assy.  
• Refer to item 4-1 for the Back Tension Torque adjustment.

6. Loading Lever Block
  - 1) Remove the ③c washer, then remove the ⑬⑰ Loading Lever Block.
7. Cylinder Assy, TG-R Spring, TG-R, Gear Arm, L1 (IN) Arm, L1 (OUT) Arm, Rotor Block, ⑭⑭ Loading Link Block, INC (IN) Base, ⑮⑮ Loading Link Block, INC Base Block, ⑳⑳ Roller Guide

- 1) Unscrew the six ⑦ screws, turn the Base Mechanism Unit upside down, then remove the ⑳⑳ Cylinder Assy with the ㉔⑲ Rotor Block pushed downward.
- 2) Remove, from the Cylinder Assy, the ㉔⑳ Gear Arm, ㉔㉕ L1 (IN) Arm, ㉔㉖ L1 (OUT) Arm, ㉔㉗ TG-R, and ㉔㉘ TG-R Spring, in this order.
- 3) Pull out the Rotor Block from the Cylinder Assy (When reinstalling, be sure to put the two ④ washers on the Cylinder Assy.)
- 4) Unscrew the two ⑧ screw, then remove the ⑭⑭ Loading Link Block, ㉔⑳ INC (IN) Base, ⑮⑮ Loading Link Block, ㉔㉙ INC Base Block from the Cylinder Assy.

3. Sensor Block, ID Spacer (L), ID Spacer (R)
  - 1) ⑤cネジ 1本を外す。
  - 2) ⑥ネジ 2本を外し、㉔⑳ Sensor Block, ㉔㉕ ID Spacer (L), ㉔㉖ ID Spacer (R) を外す。  
注意・組立の時、⑥ネジを斜めに締めつけないこと。(Switchが斜めになる為。)
4. ⑥① TU Assy, ⑥①-1 TU Assy
  - 1) ⑫ワッシャ 2個を外し、両方の TU Assyを外し、①ワッシャ 2個を外す。 Fig. 3-4参照

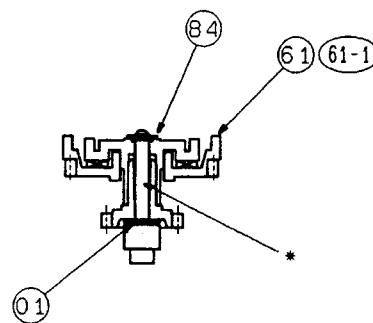

Apply Molicoat to the shaft marked with \* when reinstalling (61) and (61-1).

(61)、(61-1) の組込み時に\*印の軸にモリコートを塗布すること。

Fig. 3-4

5. BT Arm, BT Spring, BT Band Assy
  - 1) ③a ワッシャを外し、④⑥ BT Springを外す。
  - 2) ⑥⑥ BT Band Assyのフックを③⑨ BT Armより外し、BT Armを外す。
  - 3) ③b ワッシャを外し、⑩a ネジを外し、BT Band Assyを外す。  
注意・BT Band AssyのBandの変形に注意すること。  
•バック・テンション・トルク調整は4-1項を参照
6. Loading Lever Block
  - 1) ③c ワッシャを外し、⑬⑰ Loading Lever Blockを外す。

- Notes** : • Be careful NOT to scratch, the Cylinder.
- See that the phases of the Gear Arm, L1 (IN) Arm, and L1 (OUT) Arm are matched with each other, as shown in Fig. 3-5.
  - When disassembling or reinstalling the Rotor Block, be careful NOT to scratch the metal of the Cylinder Assy.
  - For height of the washer after reinstalling the Rotor Block, refer to Fig. 3-6. Wipe out the oil lubricated to the shaft with an alcohol.
  - When disassembling or reassembling the Cylinder Assy, carry out the adjustment of the Capstan Motor's FG output shown in Fig. 3-7.

### 8. Loading Belt, Loading Gear Block

- 1) Remove the (20) Loading Belt from the Base Mechanism Unit.
- 2) Unscrew the four (5)d screws, then remove the (19) Loading Gear Block.

- Notes** : • Be careful NOT to scratch the gear of the Loading Gear Block.
- Be careful NOT to let grease adhere to the Loading Belt.

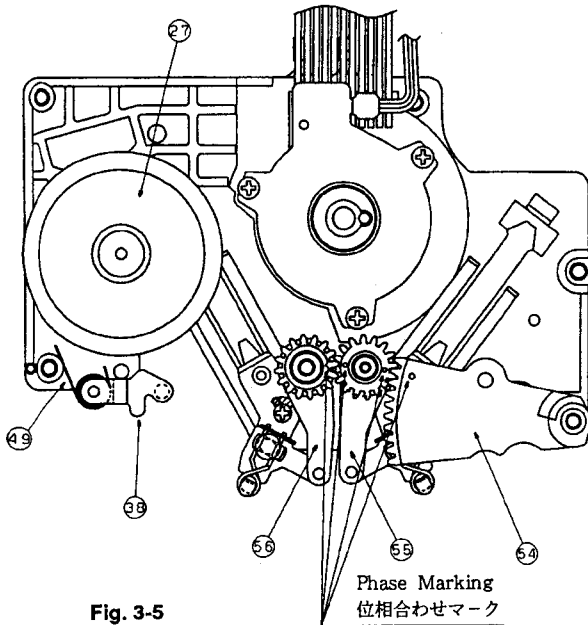

Fig. 3-5

### 7. Cylinder Assy, TG-R Spring, TG-R, Gear Arm, L1 (IN) Arm, L1 (OUT) Arm, Rotor Block, (14) Loading Link Block, INC (IN) Base, (15) Loading Link Block, INC Base Block, (28) Roller Guide

- 1) (7)ネジ 6本を外し、ベース・メカ・ユニットを逆さにして、(27) Rotor Blockを下に押しながら、(30) Cylinder Assyを外す。
- 2) Cylinder Assyから (54) Gear Arm, (55) L1 (IN) Arm, (56) L1 (OUT) Arm, (38) TG-R, (49) TG-R Springの順に外す。
- 3) Rotor BlockをCylinder Assyより抜き取る (組立の時、(4)ワッシャ 2コをはめること)。
- 4) (8)ネジ 2本を外し (14) Loading Link Block, (24) INC (IN) Base, (15) Loading Link Block, (25) INC Base BlockをCylinder Assyより外す。

- 注意** ・ シリンダに傷等をつけないようにすること。
- Gear Arm, L1 (IN) Arm, L1 (OUT) Armの位相は Fig. 3-5を参照。
  - Rotor Blockの分解組立の時、Cylinder Assyのメタルに傷等を付けないこと。
  - Rotor Block組立後のワッシャの高さはFig. 3-6を参照。又、シャフトのオイルをアルコール等で拭き取ること。
  - Cylinder Assyを分解組立後、Fig. 3-7に示すキャプスタン・モータのFG出力調整を行うこと。

### 8. Loading Belt, Loading Gear Block

- 1) ベース・メカ・ユニットより、(20) Loading Beltを外す。
- 2) (5)dネジ 4本を外し、(19) Loading Gear Blockを外す。

- 注意** ・ Loading Gear Blockのギアに傷等をつけないようにすること。
- Loading Beltにグリス等をつけないようにすること。

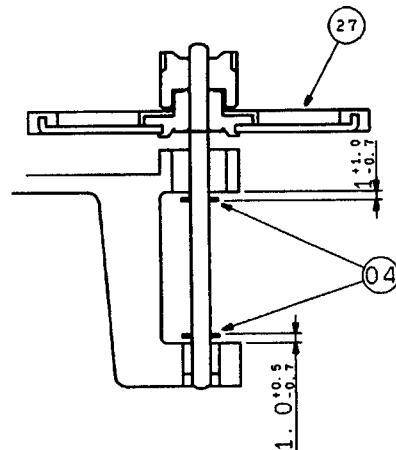
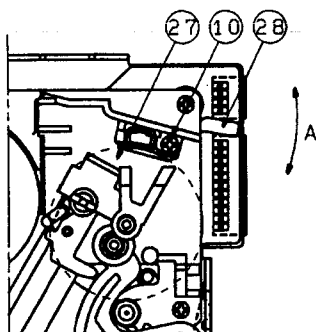

Fig. 3-6



Loosen the (10) screw, then move the (28) Sensor Block to the right and left (↗A) so that FG output of the Capstan Motor can be obtained. Tighten the (10) screw with a torque of 1.5 kg-cm, and then apply the screw-locking compound to it. The gap between (27) and (28) should be more than 60 μm.

(10) ネジを緩めて、Capstan MotorのFG出力が得られる様に(28) Sensor Blockを左右に動かして(↗A)調整する。そして、(10) ネジを1.5 kg-cmで締め付けネジ・ロックをする。但し、(27)と(28)とのギャップは60 μm以上とする。

Fig. 3-7



## 3-4. Disassembly of the Base Mechanism Unit -2 (Fig. 3-8)

3-4. ベース・メカ・ユニットの分解 -2 (Fig. 3-8)

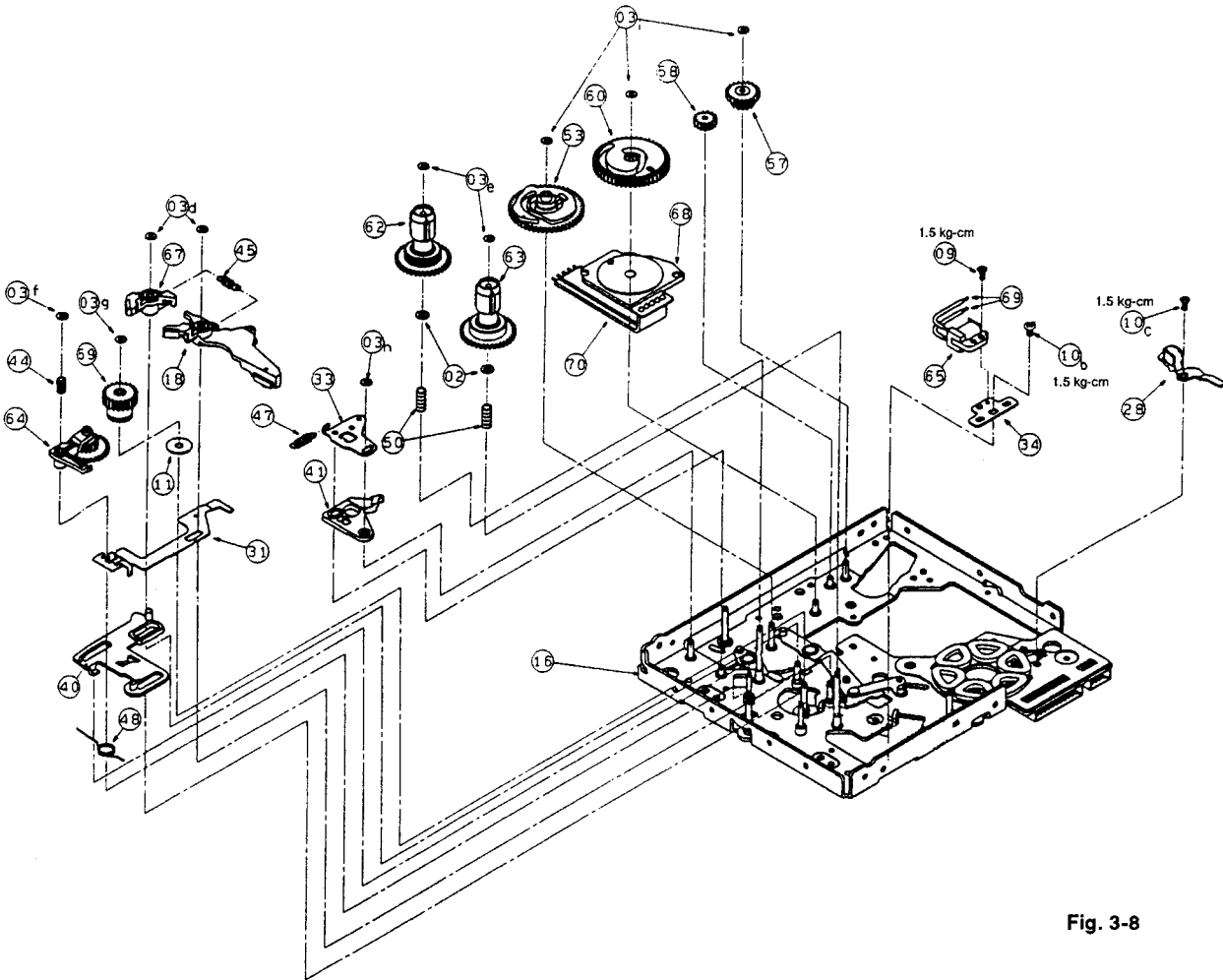
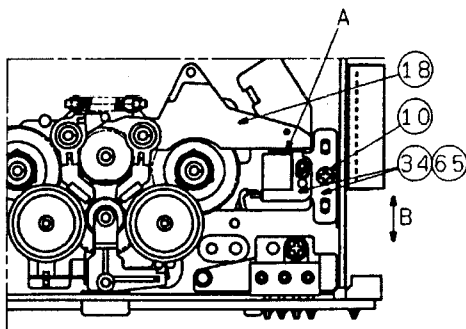

Fig. 3-8

1. Solenoid Bracket, Solenoid, (69) Lead Wires
  - 1) Unscrew the (10) b screws, then remove the (65) Solenoid.
  - 2) Unscrew the (9) screws, then remove the (34) Solenoid Bracket from the Solenoid.

**Note** : • For adjusting the position of the Solenoid, refer to Fig. 3-9.

1. Solenoid Bracket, Solenoid, (69) リード線
    - 1) (10) b ネジを外し、(65) Solenoidを外す。
    - 2) (9)ネジを外し、(34) Solenoid BracketをSolenoidより外す。
- 注意・Solenoidの位置調整はFig. 3-9を参照。



- Loosen the (10) screws, then move the Solenoid ((34) (65)) back and forth (↗B) so that no space at "A" portion can be obtained in Play mode. After checking that the brakes are not applied in FF mode, tighten the (10) screw with a torque of 1.5 kg-cm, then apply the screw-locking compound to it.

- PLAYモードにて、A部の隙間が無い様に(10)ネジを緩めてSolenoid((34)(65))を前後に動かして(↗B)調整する。またFFモードにてブレーキがかかっていないことを確認し、(10)ネジを1.5 kg-cmで締め付けネジ・ロックをする。

Fig. 3-9

2. Brake Spring, Loading Lever Block, SU Brake Arm
- 1) Disengage the (45) Brake Spring.
  - 2) Remove the two (3d) washers, then detach the (18) Loading Lever Block and (67) SU Brake Arm.
3. Reel Assy (SU), Reel Assy (TU), SU Reel Spring (Refer to Fig. 3-10)
- 1) Take off the two (3e) washers, then remove the (62) Reel Assy (SU), (63) Reel Assy (TU), two (50) SU Reel Spring, and two (2) washer.

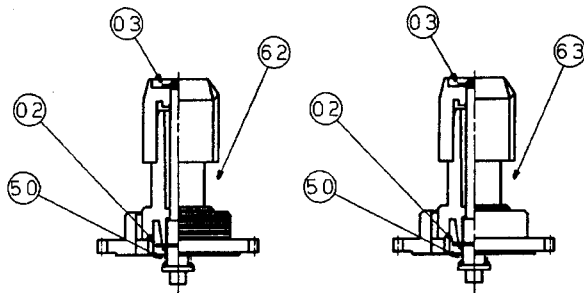

2. Brake Spring, Loading Lever Block, SU Brake Arm
- 1) (45) Brake Springを外す。
  - 2) (3d)ワッシャ 2ヶを外し、(18) Loading Lever Block, (67) SU Brake Armを外す。
3. Reel Assy (SU), Reel Assy (TU), SU Reel Spring (Fig. 3-10参照)
- 1) (3e)ワッシャ 2ヶを外し、(62) Reel Assy (SU), (63) Reel Assy (TU), (50) SU Reel Spring 2ヶ、(2)ワッシャ 2ヶを外す。

Notes:

- Apply Molicoat to the spindle when reinstalling (62) and (63).
- See that no Molicoat is applied to the reflector plate of (62) and (63).
- See that the serrated portion of (62) is free from Molicoat coating, scratches and indentation.

注記:

- (62) (63) の組込み時に軸にモリコート塗布すること。
- (62) (63) の反射板にモリコートをつけないこと。
- (62) の挽目部にモリコート及び傷、打痕をつけないこと。

Fig. 3-10

4. Idle Spring, Idle Gear, Center Pulley, Cam Plate, Idle Cam, Cam Plate Spring, BT Lever Spring, BT Lever, BT Cam Lever (Refer to Figs. 3-11, 3-12)

- 1) Take off the (3f) washer, then remove the (44) Idle Spring and (64) Idle Gear.
- 2) Remove the (3g) washer, then detach the (59) Center Pulley and (11) washer.
- 3) Disengage the (48) Cam Plate Spring from the hook, remove the (31) Cam Plate and (40) Idle Cam, then take off the Cam Plate Spring.
- 4) Disengage the (47) BT Lever Spring.
- 5) Remove the (3h) washer, then detach the (33) BT Lever and (41) BT Cam Lever.

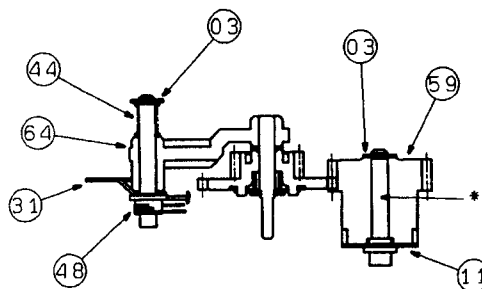

Notes:

- Apply Molicoat to the spindle marked \* when incorporating (59).
- When reinstalling (31), apply Molicoat to two oblong holes and the spring hook.

注記:

- (59) の組込み時に\*印の軸にモリコート塗布すること。
- (31) の組込み時に長穴 (2ヶ所) 及びバネ・フック部にモリコート塗布すること。

Fig. 3-11

4. Idle Spring, Idle Gear, Center Pulley, Cam Plate, Idle Cam, Cam Plate Spring, BT Lever Spring, BT Lever, BT Cam Lever (Figs. 3-11, 3-12参照)

- 1) (3f) ワッシャを外し、(44) Idle Spring, (64) Idle Gearを外す。
- 2) (3g) ワッシャを外し、(59) Center Pulley, (11)ワッシャを外す。
- 3) (48) Cam Plate Springをフックから外し、(31) Cam Plate, (40) Idle Camを外し、Cam Plate Springを外す。
- 4) (47) BT Lever Springを外す。
- 5) (3h) ワッシャを外し、(33) BT Lever, (41) BT Cam Leverを外す。

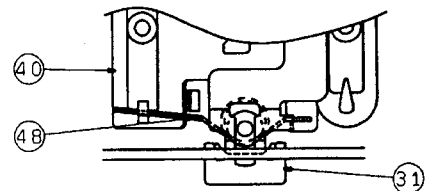

Fig. 3-12

5. Worm Wheel, Center Gear, Mode Gear, Mode Cam, Mode Switch ( ⑦⑩ 5-conductor J cable)

- 1) Remove the three ③i washers, then detach the ⑤⑦ Worm Wheel, ⑤⑧ Center Gear, ⑥⑩ Mode Gear, ⑤③ Mode Cam, and ⑥⑧ Mode Switch, in this order.

**Notes :** • See that the phases of the Mode Gear and the Mode Cam when reinstalling are matched with each other, as shown in Fig. 3-13.

- After the phases are matched, move the Mode Gear in the direction of arrow A by an angle of about 40 degrees.

6. Sensor Block

- 1) Desolder the four soldered portions, unscrew the ⑩c screw, then detach the ②⑧ Sensor Block.

**Note :** • For the adjustment of the Capstan Motor's FG output when reinstalling, refer to Fig. 3-7.

5. Worm Wheel, Center Gear, Mode Gear, Mode Cam, Mode Switch ( ⑦⑩ 5芯J線)

- 1) ③i ワッシャ 3ヶを外し、⑤⑦ Worm Wheel, ⑤⑧ Center Gear, ⑥⑩ Mode Gear, ⑤③ Mode Cam, ⑥⑧ Mode Switch の順に外す。

注意 • 組立時の Mode Gear と Mode Cam との位相は、Fig. 3-13 を参照。

- 位相合わせ後は Mode Gear を矢印 A 方向に約 40° 動かしておくこと。

6. Sensor Block

- 1) 半田付け 4ヶ所を外し、⑩c ネジを外し、②⑧ Sensor Block を外す。

注意 • 組立時のキャプスタン・モータの FG 出力調整は Fig. 3-7 を参照のこと。

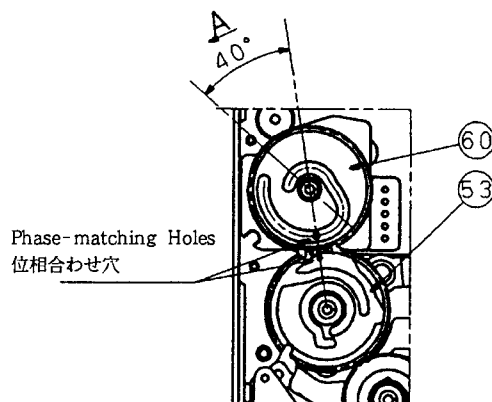

Fig. 3-13

## 3-5. Disassembly of the Cassette Holder Unit -1 (Fig. 3-14)

## 3-5. カセット・ホルダ・ユニットの分解 -1 (Fig. 3-14)

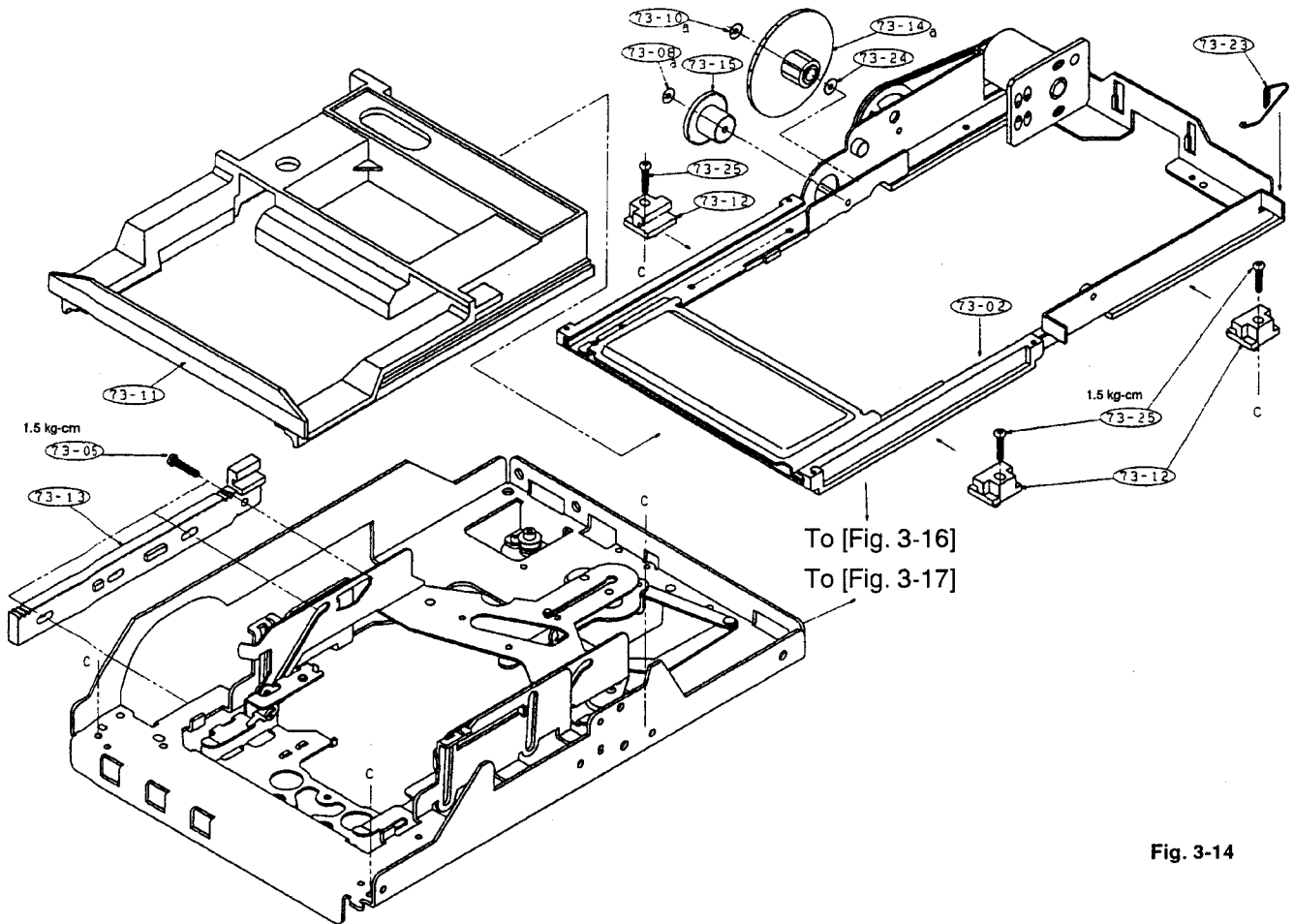

Fig. 3-14

### 1. Cassette Holder

- 1) Remove the (73)-10a washer, then detach the (73)-14a Drive Gear.
- 2) Remove the (73)-08a washer, then detach the (73)-15 Timing Gear.
- 3) Slide the Cassette Holder forward, then remove it.

**Notes** : • Handle the (73)-11 Cassette Holder with care so that it is not damaged, dented, etc.  
• For reinstalling the Cassette Holder, refer to Fig. 3-15.

### 2. (73)-02 Holder Block

- 1) Unscrew the three (73)-05 screws, then detach the (73)-13 Gear Rack.
- 2) Unscrew the three (73)-25 screws, then detach the three (73)-12 Tray Bushing.

### 1. Cassette Holder

- 1) (73)-10a ワッシャを外し、(73)-14a Drive Gearを外す。
- 2) (73)-08a ワッシャを外し、(73)-15 Timing Gearを外す。
- 3) Cassette Holderを前面にスライドさせて外す。

注意 • (73)-11 Cassette Holderに傷、打痕等付けない様に、取扱に注意すること。

• Cassette Holderの取り付けは、Fig. 3-15を参照。

### 2. (73)-02 Holder Block

- 1) (73)-05 ネジ3本を外し、(73)-13 Gear Rackを外す。
- 2) (73)-25 ネジ3本を外し、(73)-12 Tray Bushing 3ヶを外す。

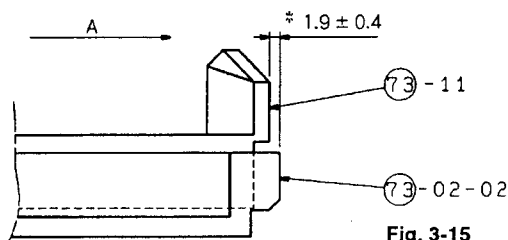

Fig. 3-15

When reinstalling the Cassette Holder, pull out the (73)-02-02 Holder Block fully forward (direction A in Fig 2-15), then reinstall the Timing Gear with the front of the Cassette Holder positioned in accordance with the dimension marked with \*.

Cassette Holderを組み込む時は、(73)-02-02) Holder Blockを前面に完全に引き出し (図示A方向)、Cassette Holderの前面を図示\*印寸法に合わせた状態でTiming Gearを組み込むこと。

## 3-6. Disassembly of the Cassette Holder Unit -2 (Fig. 3-16)

## 3-6. カセット・ホルダ・ユニットの分解 -2 (Fig. 3-16)

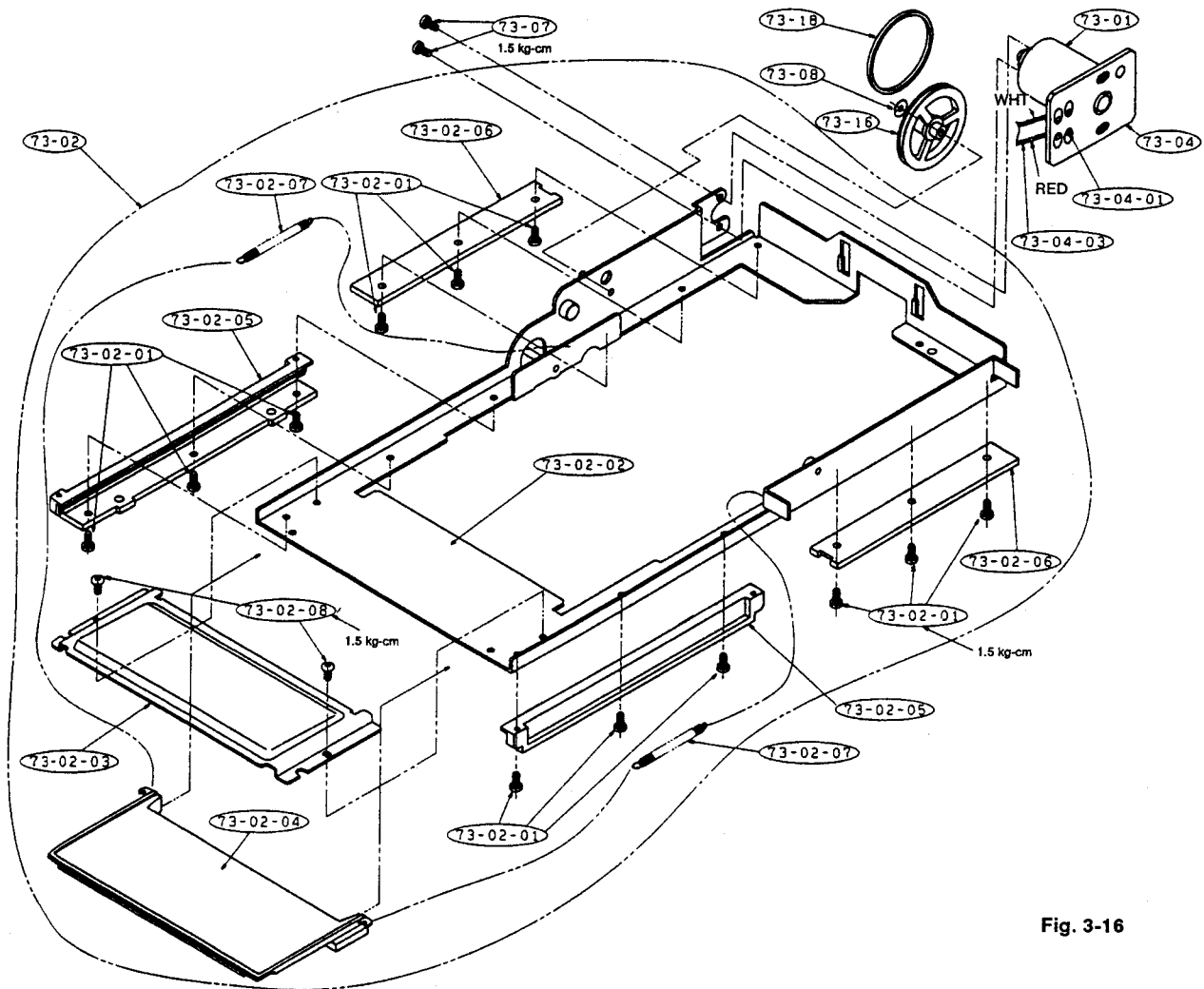

Fig. 3-16

### 1. Slider

- 1) Disengage the two ⑦③-02-07 Spring.
- 2) Unscrew the two ⑦③-02-08 screws, then detach the ⑦③-02-03 Slider Cover.
- 3) Unscrew the six ⑦③-02-01a screws, remove the two ⑦③-02-05 Front Spacer, then detach the ⑦③-02-04 Slider.

**Note** : • Handle the Slider and Slider Cover with care so that it is not damaged, dented, etc.

### 1. Slider

- 1) ⑦③-02-07 Spring 2本を外す。
- 2) ⑦③-02-08 ネジ 2本を外し、⑦③-02-03 Slider Coverを外す。
- 3) ⑦③-02-01a ネジ 6本を外し、⑦③-02-05 Front Spacer 2ヶを外し、⑦③-02-04 Sliderを外す。

注意 • Slider, Slider Coverに傷、打痕等を付けない様に、取り扱うこと。

## 3-7. Disassembly of the Cassette Holder Unit -3 (Fig. 3-17)

## 3-7. カセット・ホルダ・ユニットの分解 -3 (Fig. 3-17)

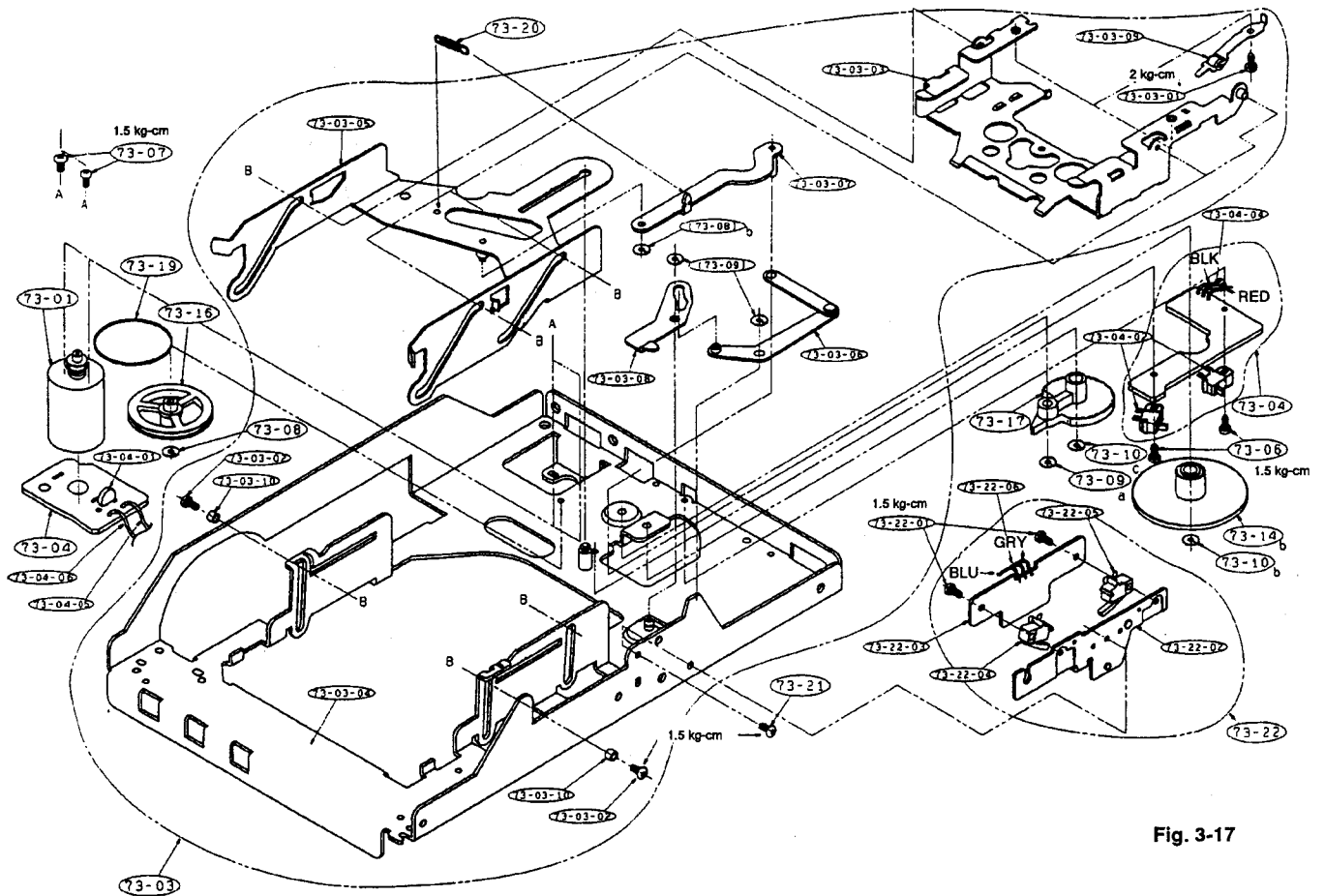

Fig. 3-17

### 1. Cassette Holder

- 1) Remove the two (73)-03-02 screws and two (73)-03-10 Collars.
- 2) Slide the (73)-03-05 Holder Base Block backward by about 15 mm, then remove the (73)-03-03 Cassette Holder.

### 2. Holder Base Block, RIV Link Slider Assy

- 1) Disengage the (73)-20 Spring.
- 2) Remove the (73)-10b washer, then detach the (73)-14b Drive Gear.
- 3) Remove the (73)-10c, (73)-09a washers, then detach the (73)-17 Crank Gear.
- 4) Remove the (73)-08b washer, then detach the (73)-03-05 Holder Base Block and (73)-03-07 RIV Link Slider Assy.

### 1. Cassette Holder

- 1) (73)-03-02 ネジ 2本と、(73)-03-10 Collar 2ヶを外す。
  - 2) (73)-03-05 Holder Base Block を後方へ約15mm程度スライドさせて、(73)-03-03 Cassette Holder を外す。
- ### 2. Holder Base Block, RIV Link Slider Assy
- 1) (73)-20 Spring を外す。
  - 2) (73)-10b ワッシャをを外し、(73)-14b Drive Gear を外す。
  - 3) (73)-10c, (73)-09a ワッシャをを外し、(73)-17 Crank Gear を外す。
  - 4) (73)-08b ワッシャをを外し、(73)-03-05 Holder Base Block と (73)-03-07 RIV Link Slider Assy を外す。

## 4. ADJUSTMENT OF THE MECHANISM

### 機構部調整

This adjustment is performed when mechanical parts have been replaced or when torque value is adjusted or tape travel is erratic.

この調整は、機構部品を交換したときまたは又はトルク値、テープの走りが悪い場合に行う。

#### 4-1. Back Tension Torque Adjustment

1. Load a torque measurement tape (TW-7131 manufactured by SONY), then measure the back tension torque with the deck in REC/PLAY mode.
2. So that the center value of the back tension torque swing falls within a range of 5 to 7 g·cm, adjust by loosening the ⑩ screw in Fig. 4-1 then by moving the ⑥⑥ BT Band Assy (plastic mold fabrication) to the right and left as shown in A of Fig. 4-1.
3. After adjusting, tighten the ⑩ screw, then apply the screw-locking compound to it.

#### 4-1. バック・テンション・トルク調整

1. トルク測定用テープ (SONY製 TW-7131) を装着し、REC/PLAYモードにてバック・テンション・トルクを測定する。
2. バック・テンション・トルク値の振幅の中心が5 ~ 7 g·cmとなるように、Fig. 4-1の⑩ネジをゆるめて⑥⑥ BT Band Assy成形品をFig. 4-1のAの様に左右に動かして、調整する。
3. 調整後、⑩ネジを締め付けてネジ・ロックをする。

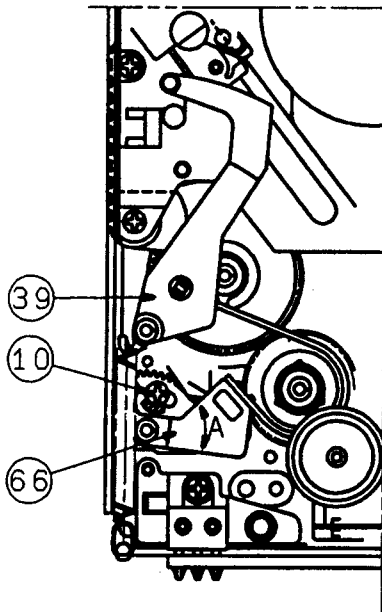

- So that the center value of the back tension torque swing falls within a range of 5 to 7 g·cm, adjust by loosening the (10) screw then by moving the (66) BT Band Assy (plastic mold fabrication) to the right and left as shown in "A" of figure. After that, tighten the (10) screw with a torque of 0.8 kg-cm, then apply the screw-locking compound to it.
- (10) ネジを緩めて、バック・テンション・トルクがセンタ 5 ~ 7 g-cmとなる様に (66) BT Band Assyの成型品を左右に動かして (A) 調整する。そして、(10) ネジを 0.8 kg-cmで締め付けネジ・ロックをする。

Fig. 4-1

## 4-2. Tape Travel Adjustment

Prior to adjustment, clean dirt and dust off all posts and the head drum other than the guide roller, using a cotton swab moistened with Difflon.

Gently wipe the guide roller with a cotton swab moistened with alcohol.

## 4-2. テープ走行調整

調整の前にガイドローラー以外の各走行ポスト及びシリンダーの汚れを、ダイフロンを綿棒に浸し拭きとって下さい。

尚、ガイドローラーはアルコールを綿棒に浸し、軽く拭きとって下さい。

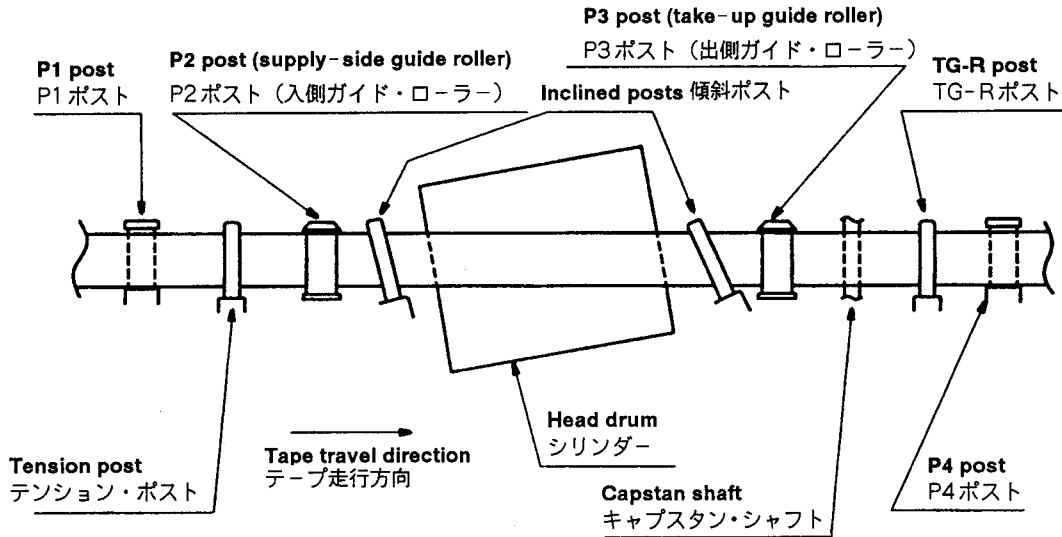

Fig. 4-2

1. Load a tape travel adjustment tape (TY-7251 manufactured by SONY), then set the deck to PLAY mode.
2. Connect CH1 of the oscilloscope to TP101-1 (RFMON) on the DIGITAL SERVO PCB and CH2 to TP13 (SWH). While observing the envelope of the RF signal, adjust the height of the guide roller as follows:

- 1). Turn the P2 post (supply-side guide roller) clockwise using a wrench until the margin area on the envelope (supply-side) disappears, then turn the guide roller counterclockwise until the margin area reappears. (Fig. 4-3)
- 2). Turn the P3 post (take-up side guide roller) clockwise using a wrench until the margin area on the envelope (take-up side) disappears, then turn the guide roller counterclockwise until the margin area reappears. (Fig. 4-4)

1. 走行調整用テープ (SONY製 TY-7251) を装着し、PLAYモードにする。
2. オシロスコープの CH1をDIGITAL SERVO PCBの TP101-1 (RFMON)に、CH2をTP13 (SWH)に接続し、RF信号のエンベロープを観測しながら、以下のようにガイドローラーの高さを調整する。

- 1). P2ポスト(入側ガイドローラー)を二股レンチにて右に回し、エンベロープの入側のマージン・エリア部が無くなるまで下げ、今度はガイドローラーを左に回し、マージン・エリア部が出るまで戻す。(Fig. 4-3)
- 2). P3ポスト(出側ガイドローラー)を二股レンチにて右に回し、エンベロープの出側のマージン・エリア部が無くなるまで下げ、今度はガイドローラーを左に回し、マージン・エリア部が出るまで戻す。(Fig. 4-4)

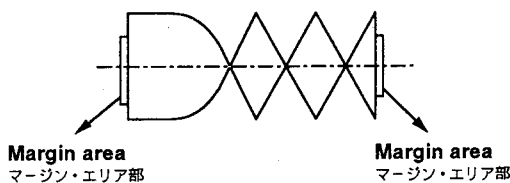

Fig. 4-3

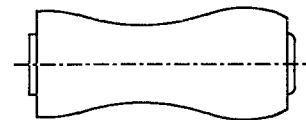

Fig. 4-4



- 3). Gently turn the guide rollers on both sides until the envelope becomes as shown in Fig. 4-5.  
At this time, the lower edge of the tape should be completely on the drum lead.

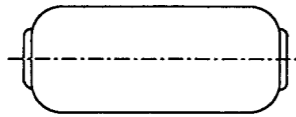

Fig. 4-5

- 4). Gently turn the guide rollers on both sides counterclockwise until the envelope becomes as shown in Fig. 4-6.  
**Reference).** The shape of the envelope when the tape is running outside the drum lead is shown in Fig. 4-7.

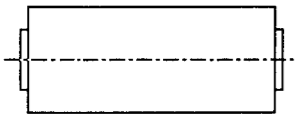

Fig. 4-6

	Small deviation 外れ量 小	Medium deviation 外れ量 中	Large deviation 外れ量 大
Input side 入側			
Output side 出側			

Fig. 4-7

- 5). After the adjustment is complete, eject the tape, then load it again and confirm whether or not the envelope is as shown in Fig. 4-6. If NOT, go back to 1), and perform the adjustment again.  
6). After the adjustment is complete, check to make sure that the tape is NOT curled around the guide rollers.  
7). Play back the TY-7251 tape and check to see that the flat portion of the envelope is as shown in Fig. 4-8.

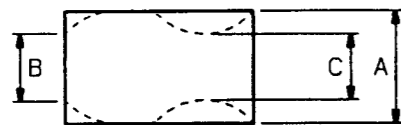

Fig. 4-8

- 3). 両側のガイドローラーを少しずつ調整して、エンベロープを Fig. 4-5 のような形状にする。  
このとき、テープの下エッジがシリンドラーのリードに完全に乗っている状態になります。

- 4). 両側のガイドローラーを互いに少しずつ左側に回し、エンベロープを Fig. 4-6 のような形状にする。  
参考). テープがシリンドラーのリードから外れて走行している場合のエンベロープの形状は、Fig. 4-7 のようになります。

- 5). 調整後、一度テープを EJECT し、再度ローディングを行ないエンベロープが Fig. 4-6 のような形状になっているかを確認する。なっていない場合には、再度 1) 項に戻って調整する。  
6). 調整終了後、ガイドローラーでテープがカールしていないことを確認する。  
7). TY-7251 テープを再生し、エンベロープの平坦度が Fig. 4-8 の状態であることを確認する。

A/B Less than 3 dB  
A/C Less than 3 dB

A/B 3 dB以下  
A/C 3 dB以下

## 5. ELECTRICAL ADJUSTMENT 電気系調整

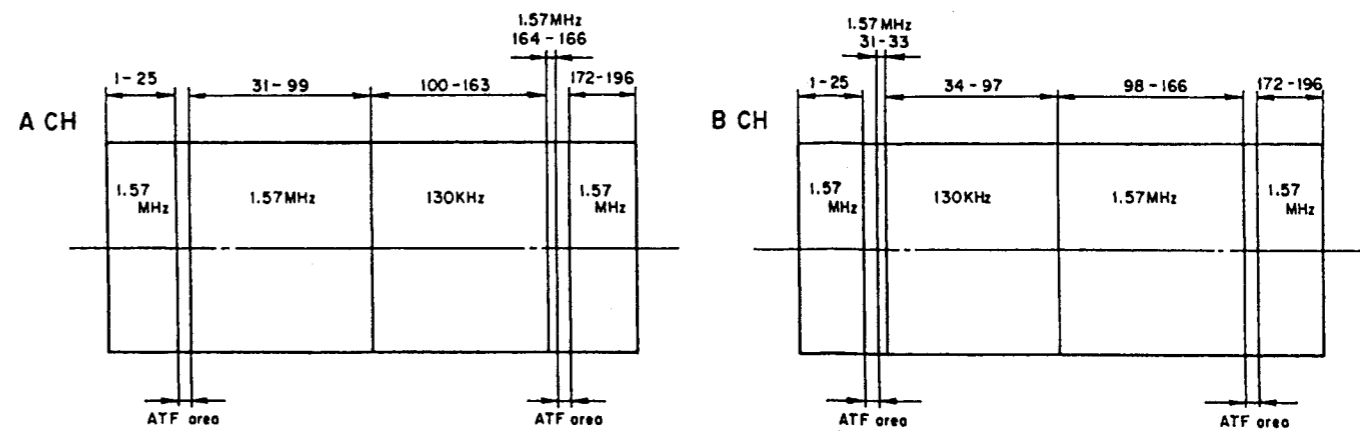

Fig. 5-1 Frequency patterns of the level checking test tape (TY-7111)  
レベル用テープ (TY-7111) 周波数パターン

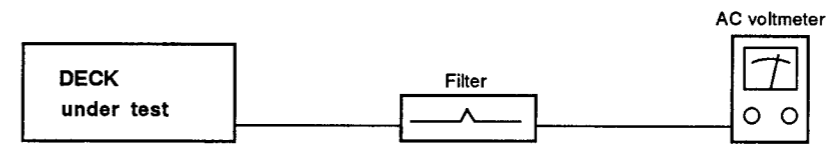

Fig. 5-2

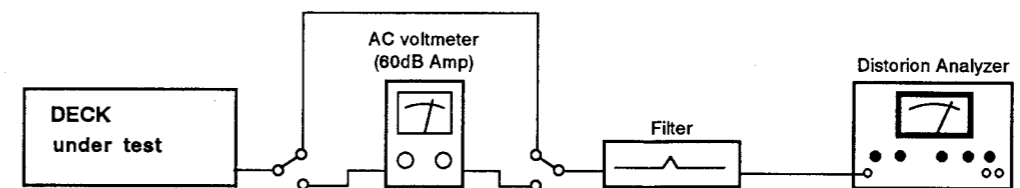

Fig. 5-3

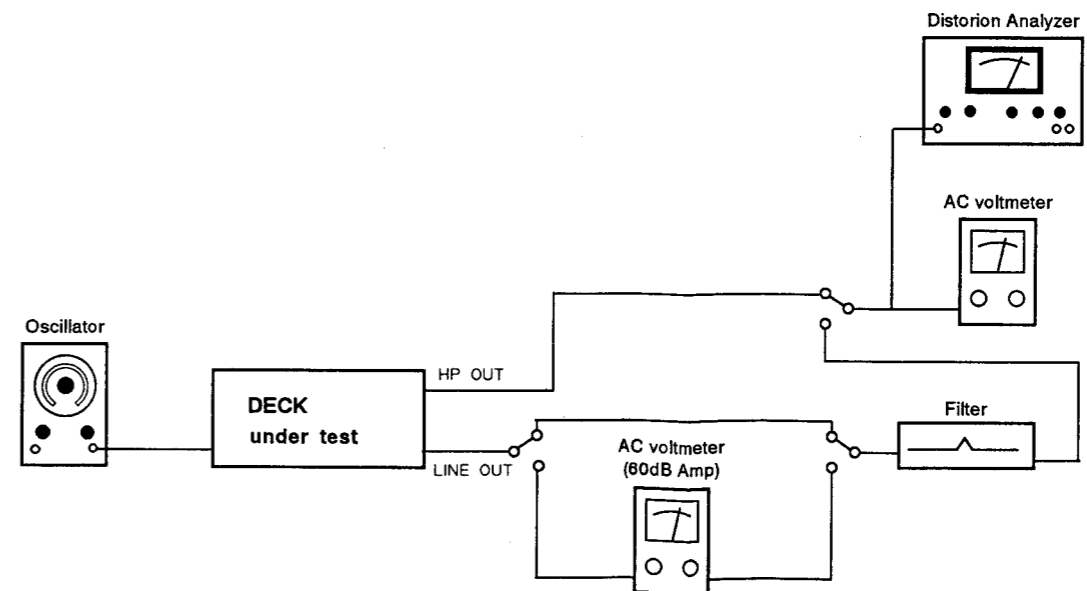

Fig. 5-4

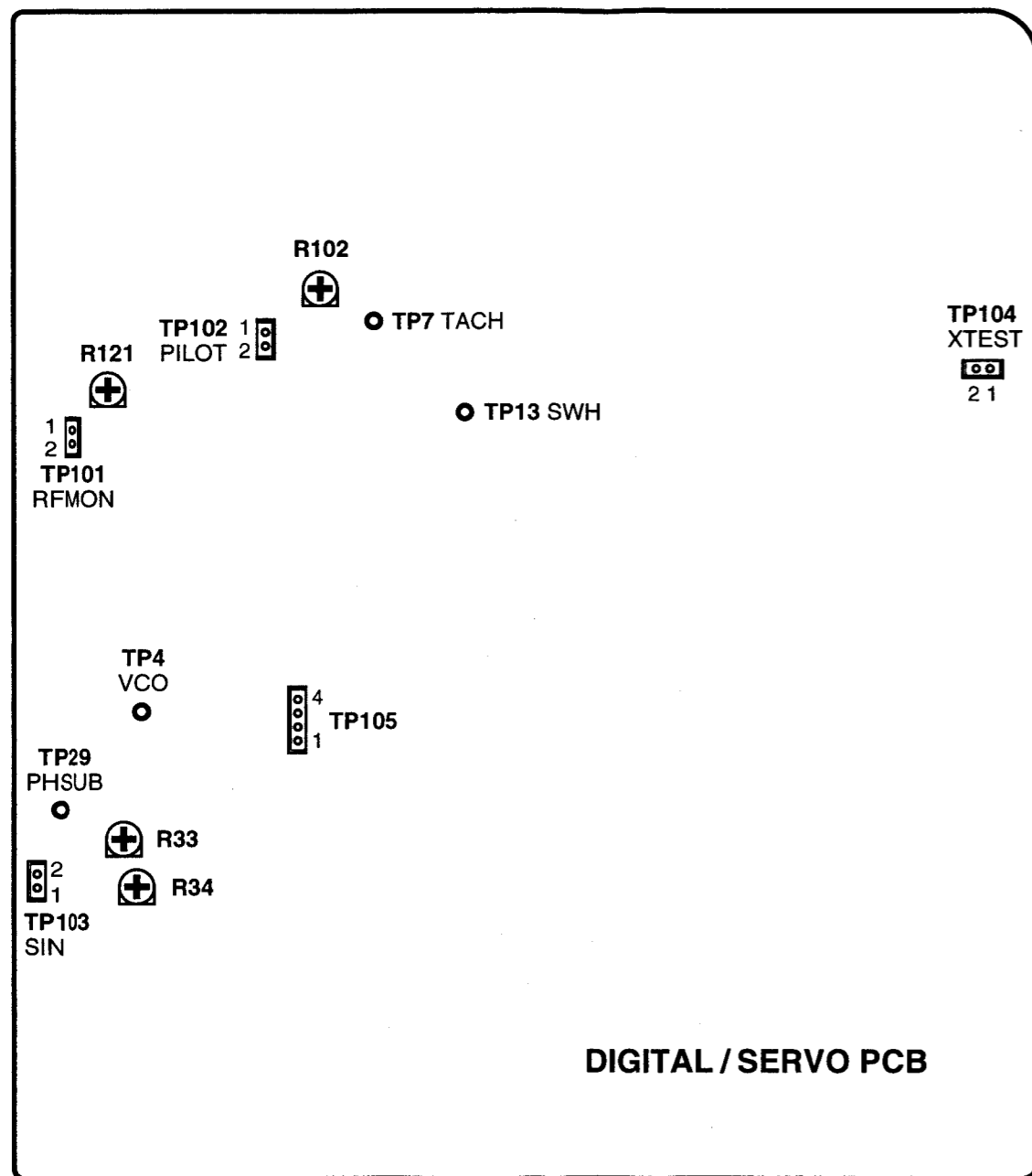

Fig. 5-5 Adjustment and test point locations (DIGITAL/SERBO PCB)

調整とテスト・ポイント個所 (DIGITAL/SERBO PCB)

**RF UNIT**

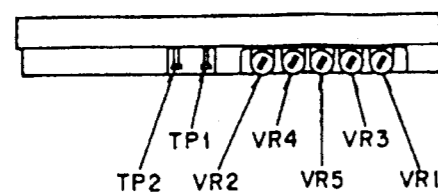

Fig. 5-6 Adjustment and test point locations (RF UNIT)

調整とテスト・ポイント個所 (RF UNIT)

**5-1. Adjustment of the Data Strobe System (Refer to Fig. 5-5.)**

1. Adjusting the VCO Offset
  - 1). Short between pin 1 and pin 2 on TP104 (XTEST). (Pin 54 of the strobe IC HD49229 goes high and the deck enters ADJUSTMENT mode.)
  - 2). Connect the DC voltmeter across TP29 (PHSUB) and GND.
  - 3). Load any tape, and then set the deck to PLAY mode.
  - 4). Adjust trimmer resistor R33 so that the voltage at TP29 is 2.5 V.
  - 5). After the adjustment is complete, release TP104.
2. Adjusting the VCO Lower Limit Frequency
  - 1). Short between pin 1 and pin 2 on TP103 (SIN).
  - 2). Connect the frequency counter across TP4 (VCO) and GND.
  - 3). Adjust R34 so that the output frequency at TP4 is 6.58 MHz.
  - 4). After the adjustment is complete, release TP103.

**5-2. Adjustment and Confirmation of the Servo System (Refer to Figs. 5-5 and 5-6.)**

Note: Some torque cassettes, when loaded, may cause the BOT and EOT detection circuits to malfunction. In rare cases, this defeats the PLAY, FF or REW operations. In such a case, before using the tape, block the tape-end detection holes on the right and left ends of the cassette with adhesive tape or the like so that light does not pass through the holes.

1. Checking the PLAY Take-up Torque
  - 1). Load a torque cassette (TW-7131 manufactured by SONY).
  - 2). When the deck is set to PLAY mode, confirm that the torque of the take-up reel is 7 to 20 g·cm.
2. Checking the REV PLAY Take-up Torque
  - 1). Load a torque cassette TW-7131.
  - 2). When the deck is set to REV PLAY mode (rotate the SHUTTLE knob to the left), confirm that the torque of the take-up reel is 10 to 26 g·cm.
3. Checking the REV PLAY Back Tension Torque
  - 1). Load a torque cassette TW-7131.
  - 2). When the deck is set to REV PLAY mode, confirm that the torque of the supply reel is 10 to 16 g·cm.
4. Checking the PLAY Back Tension Torque
  - 1). Load a torque cassette TW-7131.
  - 2). When the deck is set to PLAY mode, confirm that the torque of the supply reel is 4 to 8 g·cm.

**5-1. データ・ストロブ部調整 (図 5-5 参照)**

1. VCOオフセット調整
  - 1). TP104(XTEST)の1番ピンと2番ピン間を短絡する。(ストロブIC HD49229の54ピンが"H"になり調整モードになります)
  - 2). TP29(PHSUB)とGND間にDC電圧計を接続する。
  - 3). PLAYモードにする。テープは任意のものを使用する。
  - 4). TP29の電圧が2.5Vになるように半固定抵抗R33を調整する。
  - 5). 調整後、TP104を解放する。
2. VCO下限周波数調整
  - 1). TP103(SIN)の1番ピンと2番ピン間を短絡する。
  - 2). TP4(VCO)とGND間に周波数カウンタを接続する。
  - 3). TP4の出力周波数が6.58MHzになるようにR34を調整する。
  - 4). 調整後、TP103を解放する。

**5-2. サーボ部調整及び確認 (図 5-5, 5-6 参照)**

注意: トルク・カセットを装着した時、カセットによってはBOT、EOT検出回路が誤動作し、PLAY、FF及びREW動作に入らないことがまれに発生します。その場合は、カセットの左右にあるテープ端検知窓をシール等でふさいで、光が透過しない様にしてから、カセットを使用してください。

1. PLAY テイクアップ・トルク確認
  - 1). トルク・カセット(SONY製 TW-7131)を装着する。
  - 2). PLAYモードにしたとき、テイクアップ側リールのトルクが7~20g·cmであることを確認する。
2. REV PLAY テイクアップ・トルク確認
  - 1). トルク・カセットTW-7131を装着する。
  - 2). REV PLAYモード(SHUTTLEノブを左に回す)にしたとき、テイクアップ側リールのトルクが10~26g·cmであることを確認する。
3. REV PLAY バックテンション・トルク確認
  - 1). トルク・カセットTW-7131を装着する。
  - 2). REV PLAYモードにしたとき、サプライ側リールのトルクが10~16g·cmであることを確認する。
4. PLAY バックテンション・トルク確認
  - 1). トルク・カセットTW-7131を装着する。
  - 2). PLAYモードにしたとき、サプライ側リールのトルクが4~8g·cmであることを確認する。

## 5. Checking the FF/REW Torque

- 1). Short between pin 1 and pin 2 on TP104 (XTEST).
- 2). Load a torque cassette (TW-7231A manufactured by SONY).
- 3). With the deck in FF and REW modes, confirm that the torque of the take-up reel is 40 g·cm or more.
- 4). After the adjustment is complete, release TP104.

## 6. Checking the Tape Path

- 1). Connect CH1 of the oscilloscope to TP101-1 (RFMON) and CH2 to TP13 (SWH).
- 2). Short between pin 1 and pin 2 on TP104 (XTEST).
- 3). Load a tracking test tape (TY-7251 manufactured by SONY), then set the deck to PLAY mode.
- 4). As shown in Fig. 5-7, confirm that 80% or more of the RF waveform is flat.
- 5). After confirmation, release TP104.

## 5. FF/REW トルク確認

- 1). TP104 (XTEST)の1番ピンと2番ピン間を短絡する。
- 2). トルク・カセット (SONY製 TW-7231A) を装着する。
- 3). FFおよびREWモードで、テイクアップ側リールのトルクが40g·m以上あることを確認する。
- 4). 確認後、TP104を解放する。

## 6. テープ・パス確認

- 1). オシロスコープのCH1をTP101-1 (RFMON)に、CH2をTP13 (SWH)に接続する。
- 2). TP104 (XTEST)の1番ピンと2番ピン間を短絡する。
- 3). トラッキング用テスト・テープ (SONY製 TY-7251) を装着し、PLAYモードにする。
- 4). 図5-7のように、RF波形の平坦度が80%以上であることを確認する。
- 5). 確認後、TP104を解放する。

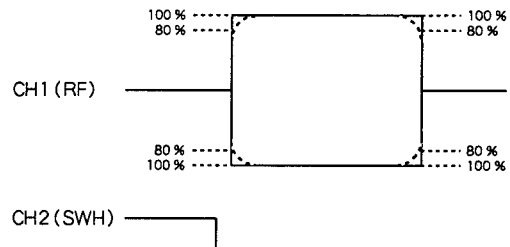

Fig. 5-7

## 7. Adjusting the TACH

- 1). Connect CH1 of the oscilloscope to TP101-1 (RFMON) and CH2 to TP7 (TACH).
- 2). Short between pin 1 and pin 2 on TP104 (XTEST).
- 3). Load a tracking test tape TY-7251, then set the deck to PLAY mode.
- 4). Adjust trimmer resistor R102 so that the time from the trailing edge of the TACH waveform to the marker of the RF waveform is  $803.6 \pm 15 \mu\text{s}$ , as shown in Fig. 5-8.
- 5). After confirmation, release TP104.

## 7. TACH調整

- 1). オシロスコープのCH1をTP101-1 (RFMON)に、CH2をTP7 (TACH)に接続する。
- 2). TP104 (XTEST)の1番ピンと2番ピン間を短絡する。
- 3). トラッキング用テスト・テープ TY-7251を装着し、PLAYモードにする。
- 4). 図5-8のように、TACH波形の立下がりからRF波形のマーカまでの時間が  $803.6 \pm 15 \mu\text{s}$  になるように半固定抵抗 R102を調整する。
- 5). 調整後、TP104を解放する。

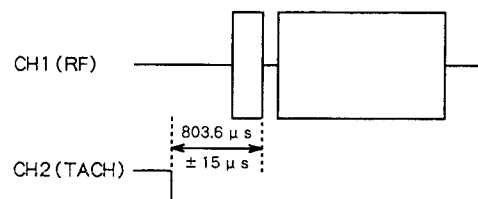

Fig. 5-8

## 8. Adjusting the Envelope Detection Level

- 1). Connect CH1 of the oscilloscope to TP101-1 (RFMON) and CH2 to TP13 (SWH).
- 2). Load a level test tape (TY-7111 manufactured by SONY) then set the deck to PLAY mode.
- 3). Adjust trimmer resistor R121 so that levels A and B of the output waveform (1.57 MHz) are  $800 \pm 100$  mV, as shown in Fig. 5-9. At this time, if the difference in output level between A and B is too great for both of them to fall within the standard range, match the higher to the standard value.

## 8. エンベロープ検出レベル調整

- 1). オシロスコープのCH1をTP101-1(RFMON)に、CH2をTP13(SWH)に接続する。
- 2). レベル用テスト・テープ (SONY製 TY-7111) を装着し、PLAYモードにする。
- 3). 図5-9のように、出力波形 (1.57MHz) A, Bのレベルが  $800 \pm 100$  mVになるように半固定抵抗 R121を調整する。このとき、AとBの出力差が大きく規格値に入らない場合は、大きい方のレベルを規格値に合わせるように調整する。

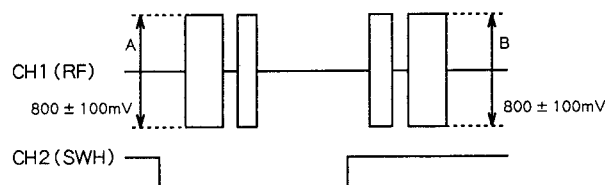

Fig. 5-9

## 9. Checking and Adjusting the Recording Current

- Notes:
- When you attempt to play the non-recorded portion of the TY-30B, a blank tape for recording, with the TP104 (XTEST) shorted, the tape travel may sometimes stop. This is not abnormal. Press the STOP button when it occurs.
  - When using the new type TY-7111X level test tape, use the new type TY-30BX blank tape for recording as well.

## 9. 記録電流の確認と調整

- 注意:
- TP104 (XTEST) を短絡した状態で、記録用ブランク・テープ TY-30B の未録音部分を PLAY モードにすると、テープ走行がストップする場合がありますが、異常ではありません。その場合は、STOP ボタンを押して下さい。
  - レベル用テスト・テープ TY-7111 が新タイプの TY-7111X の場合は、記録用ブランク・テープも新タイプの TY-30BX を使用して下さい。

### 9-1. Checking the PCM Play Level

- 1). Connect CH1 of the oscilloscope to TP101-1 (RFMON) and CH2 to TP13 (SWH).
- 2). Load a level test tape TY-7111 then set the deck to PLAY mode.
- 3). As shown in Photo. 5-1, make a note of the signal level of heads A and B at the PCM section (1.57 MHz) of the waveform.

### 9-1. PCM再生レベルの確認

- 1). オシロスコープのCH1をTP101-1(RFMON)に、CH2をTP13(SWH)に接続する。
- 2). レベル用テスト・テープ TY-7111を装着し、PLAYモードにする。
- 3). 写真5-1のように、波形のPCM部(1.57MHz)の信号レベルをAヘッド、Bヘッドそれぞれ記録(メモ)しておく。

Photo. 5-1

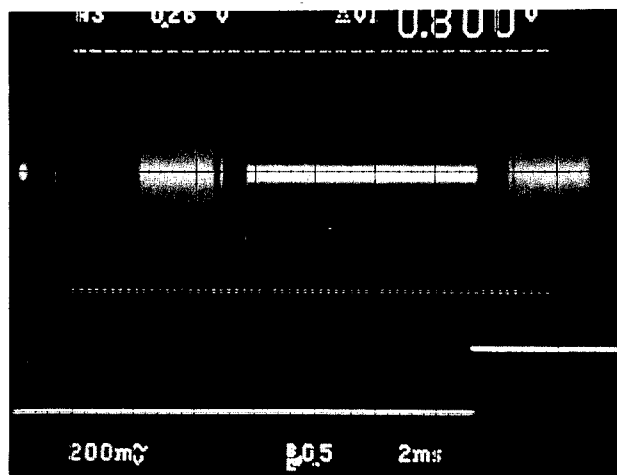

## 9-2. Checking and Adjusting the PCM Record Level

**Note).** Check and adjust this item following item 9-1.

- 1). Short between PIN 1 and pin 2 on TP104 (XTEST).
- 2). Connect CH1 of the oscilloscope to TP101-1 (RFMON) and CH2 to TP13 (SWH).
- 3). Load a blank tape TY-30B for recording.  
After loading the tape, release TP104.
- 4). Make a non-signal recording.
- 5). Rewind the recorded portion, then confirm that the playback signal levels of heads A and B of the PCM section (1.57 MHz) are within  $\pm 3$  dB of the levels noted down in 9-1 above. (Photo. 5-2)
- 6). If the values do NOT fall within the standard range, adjust the recording current controls VR2 (Ach) and VR1 (Bch) (Fig. 5-6) on the RF unit before checking them again, then repeat until they fall within the standard range.

Photo. 5-2

## 9-2. PCM記録レベルの確認と調整

注). 9-1項の確認を行なった直後に、行なってください。

- 1). TP104 (XTEST)の1番ピンと2番ピン間を短絡する。
- 2). オシロスコープのCH1をTP101-1 (RFMON)に、CH2をTP13 (SWH)に接続する。
- 3). 記録用ブランク・テープ TY-30Bを装着する。  
テープ装着後、TP104を解放する。
- 4). 無信号録音をする。
- 5). 無信号録音した部分を巻き戻し、再生したときのAヘッド、BヘッドそれぞれのPCM部(1.57MHz)の信号レベルが9-1項で記録(メモ)したレベルの $\pm 3$ dB以内であることを確認する。(写真5-2)
- 6). 規格に入らない場合は、RFユニット内の記録電流調整用半固定抵抗 VR2 (Ach), VR1 (Bch) (図5-6)を調整後、再度確認し規格に入るまで繰り返す。

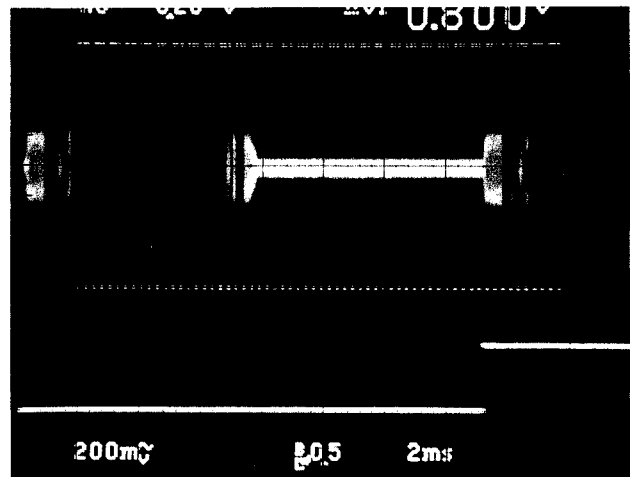

## 9-3. Checking the ATF Play Level

- 1). Connect CH1 of the oscilloscope to TP102-1 (PILOT) and CH2 to TP13 (SWH).
- 2). Load a level test tape TY-7111 then set the deck to PLAY mode.
- 3). As shown in Photo. 5-3, make a note of the signal level of heads A and B at the ATF section (130 kHz) of the waveform.

Photo. 5-3

## 9-3. ATF再生レベルの確認

- 1). オシロスコープのCH1をTP102-1 (PILOT)に、CH2をTP13 (SWH)に接続する。
- 2). レベル用テスト・テープ TY-7111を装着し、PLAYモードにする。
- 3). 写真5-3のように、波形のATF部(130kHz)の信号レベルをAヘッド、Bヘッドそれぞれ記録(メモ)しておく。

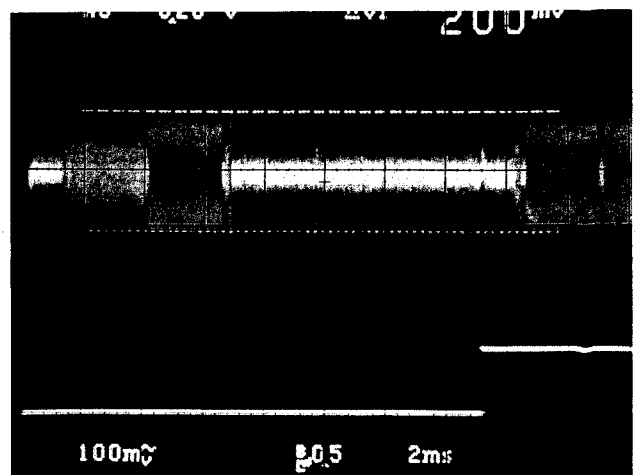

## 9-4. Checking and Adjusting the ATF Record Level

**Note).** Check and adjust this item following item 9-3.

- 1). Short between pin 1 and pin 2 on TP104 (XTEST).
- 2). Connect CH1 of the oscilloscope to TP102-1 (PILOT) and CH2 to TP13 (SWH).
- 3). Load a blank tape (TY-30B manufactured by SONY) for recording.  
After loading the tape, release TP104.
- 4). Make a non-signal recording.
- 5). Rewind the recorded portion, then confirm that the playback signal levels of heads A and B of the ATF section (130 kHz) are within  $\pm 2$  dB of the levels noted down in 9-3 above. (Photo. 5-4)
- 6). If the values do NOT fall within the standard range, adjust the recording current controls VR4 (Ach) and VR3 (Bch) (Fig. 5-6) on the RF unit before checking them again, then repeat until they fall within the standard range.

Photo. 5-4

## 9-4. ATF記録レベルの確認と調整

注). 9-3項の確認を行なった直後に、行なってください。

- 1). TP104 (XTEST)の1番ピンと2番ピン間を短絡する。
- 2). オシロスコープのCH1をTP102-1 (PILOT)に、CH2をTP13 (SWH)に接続する。
- 3). 記録用ブランク・テープ (SONY製 TY-30B) を装着する。  
テープ装着後、TP104を解放する。
- 4). 無信号録音をする。
- 5). 無信号録音した部分を巻き戻し、再生したときのAヘッド、BヘッドそれぞれのATF部 (130kHz)の信号レベルが9-3項で記録 (メモ) したレベルの $\pm 2$ dB以内であることを確認する。(写真5-4)
- 6). 規格に入らない場合は、RFユニット内の記録電流調整用半固定抵抗 VR4 (Ach), VR3 (Bch) (図5-6) を調整後、再度確認し規格に入るまで繰り返す。

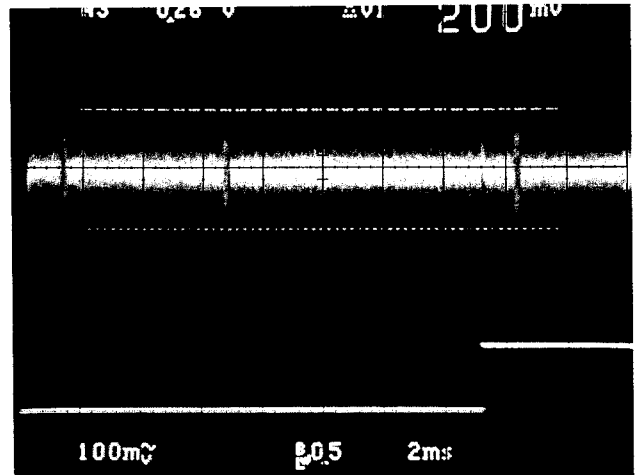

## 10. Confirming and Adjusting Error Rates

### 10-1. Confirming and Adjusting the Self-record/Play Error Rate (SP mode)

- 1). Set the REC MODE switch to STANDARD.
- 2). Load a blank tape TY-30B for recording and make a non-signal recording.
- 3). After the recording is completed, rewind the recorded portion, then connect the connector of the error rate counter (ERC-30MK2, Parts Number V00009900A) to TP105.
- 4). Play the recorded portion and confirm the error rate. At this time, the error rates of Ach and Bch should be  $6 \times 10^{-3}$  or less.
- 5). If the values do NOT fall within the standard range, turn the EQ control VR5 (Fig. 5-6) on the RF unit clockwise or counterclockwise and adjust it to the position where the error rate is optimum. When adjusting, be sure to repeat the fine adjustment. Do NOT turn the trimmer resistor largely at a time.

## 10. エラーレートの確認と調整

### 10-1. 自己録再エラーレートの確認と調整 (SPモード)

- 1). REC MODEセレクターをSTANDARDに設定する。
- 2). 記録用ブランク・テープ TY-30Bを装着し、無信号録音をする。
- 3). 録音終了後、録音部分を巻き戻し、エラーレート・カウンター (ERC-30MK2、品番V00009900A)のコンネクターをTP105に接続する。
- 4). 録音部分を再生し、エラーレートを確認する。このとき、Ach, Bchのエラーレートは $6 \times 10^{-3}$ 以下であること。
- 5). 規格に入っていない場合は、RFユニットのEQ調整用半固定抵抗 VR5 (図5-6) を左右両方向に回し、エラーレートが最良となる位置に調整する。尚、調整する時は微調整を繰り返し、一度に大幅に半固定抵抗を回転させないこと。

## 10-2. Confirming and Adjusting when the Special Error Rate Counter is not Available

- 1). Connect CH1 of the oscilloscope to pin 1 (FSYC) of TP105 and CH2 to pin 2 (FLAG).
- 2). Adjust the control where the error flag count is minimum, when the signal is recorded and played as in 10-1. (Refer to Fig. 5-10.)

## 10-2. 専用エラーレート・カウンタが無い場合の確認と調整

- 1). オシロスコープのCH1をTP105の1番ピン(FSYC)に、CH2を2番ピン(FLAG)にそれぞれ接続する。
- 2). 10-1項と同様に録音・再生したときのエラー・フラグの数が最小となる位置に調整する。(図5-10参照)

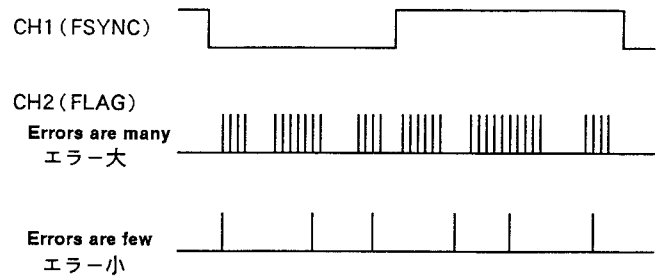

Fig. 5-10

## 10-3. Confirming the Self-record/Play Error Rate (LP mode)

- 1). In a similar manner, confirm the self-record/play error rate in LP mode (REC MODE switch setting: LONG). The rate should not be deteriorated remarkably compared with one in SP mode.

## 10-3. 自己録再エラーレートの確認 (LPモード)

- 1). 同様にLPモード (REC MODEセクター: LONG) で自己録再エラーレートを確認し、SPに比べて大幅な劣化の無い事を確認する。

## 5-3. Confirmation of the Audio System

**Note :** When making confirmation, do so with all the screws mounting the PCB Ass'y fully tightened.

### 1. Playback System

Mode : PLAY (unless otherwise specified)

Test tape : TY-7551 manufactured by SONY

Measurement points : ANALOG OUTPUTS

(BALANCED or UNBALANCED)

Adjustment Item	Preliminary	Input Signal	Adjustment Point	Measurement Method / Value Adjusted
1. PB output level	Connection : Fig. 5-2	PGM NO."1" 1 kHz, 0 dB	Check only	BAL : 20 ± 2 dBm (600 Ω load) UNBAL : 2 ± 0.5 V (10 kΩ load)
2. Playback frequency response		Filter : OUT PGM NO."1" 1 kHz PGM NO."2" 20 Hz PGM NO."3" 100 Hz PGM NO."4" 10 kHz PGM NO."5" 20 kHz	Check only	20 Hz~20 kHz ± 0.5 dB
3. Playback distortion factor	Connection : Fig. 5-3 400 Hz HPF : IN 30 kHz LPF : IN 22 kHz LPF : IN	PGM NO."1"~"5" 0 dB	Check only	0.008 % or less
4. Playback S/N ratio	Connection : Fig. 5-2 22 kHz LPF : IN IEC-A : IN	PGM NO."1" 1 kHz, 0 dB PGM NO."6" -∞	Check only	Using PGM NO."1" (0dB) as a reference, when PGM NO."6" (-∞) is played, the S/N ratio should be 95 dB or more.
5. Playback channel separation	Connection : Fig. 5-2 22 kHz LPF : IN IEC-A : IN	PGM NO."7" 1 kHz, L PGM NO."8" 10 kHz, L PGM NO."9" 1 kHz, R PGM NO."10" 10 kHz, R	Check only	When PGM NO."7" (1kHz, L) to R, PGM NO."8" (10kHz, L) to R, PGM NO."9" (1kHz, R) to L, and PGM NO."10" (10kHz, R) to L are played back, the channel separation with respect to the play nominal output should be as follows : 1 kHz : 90 dB or more 10 kHz : 90 dB or more



## 2. Monitor System

Mode : Sampling Monitor or REC-PAUSE

MONITOR mode : UNCAL

Fs : 48 kHz

Test tape : Blank tape

Adjustment Item	Preliminary	Input Signal	Adjustment Point	Measurement Method / Value Adjusted
1. LINE minimum input level	Connection : Fig. 5-4 INPUT control : MAX Filter : OUT	BAL : 1 kHz, 4 dBm UNBAL : 1 kHz, -10 dBv (316 mV)	Check only	When the input signal level is within a range of $+4 \pm 2$ dBm (UNBAL : $-10 \pm 2$ dBv), there should be a level at which the OVER indicator of the level meter starts lighting.
2. LINE nominal input/output level	Connection : Fig. 5-4 INPUT control : MIN Filter : OUT	BAL : 1 kHz, 20 dBm UNBAL : 1 kHz, 6 dBv	INPUT control	Turn the INPUT control, and set the level at which the OVER indicator of the level meter almost lights. The output level at this point should be as follows : BAL : $20 \pm 2$ dBm (600 $\Omega$ load) UNBAL : $2 \pm 0.5$ V (100 k $\Omega$ load)
3. Monitor frequency response	Connection : Fig. 5-4 Filter : OUT	BAL : 1 kHz, 20 dBm 20 Hz ~ 20 kHz, 20 dBm UNBAL : 1 kHz, 6 dBv 20 Hz ~ 20 kHz, 6 dBv	Check only	With the output level in item 2 set at 0 dB, when the frequency is varied as follows, check the output level : 20 Hz ~ 20 kHz : $\pm 0.5$ dB
4. Confirming the level meter		BAL : 20 Hz ~ 20 kHz, 20 dBm UNBAL : 20 Hz ~ 20 kHz, 6 dBv	Check only	When checking item 3, check the level meter as well to see that the "0" dot is lit at all times.
5. Headphone output level		BAL : 1 kHz, 20 dBm UNBAL : 1 kHz, 6 dBv	PHONES knob	When checking item 2, the headphone output level when the PHONES knob is turned to maximum position should be 0.9 Vrms or more (100 mW/8 $\Omega$ ).

## 3. Recording System

Mode : REC mode → PLAY mode

Test tape : Blank tape

Adjustment Item	Preliminary	Input Signal	Adjustment Point	Measurement Method / Value Adjusted
1. Record/play output level	Connection : Fig. 5-4	BAL : 1 kHz, 20 dBm UNBAL : 1 kHz, 6 dBv	Check only	With the deck in the condition of 2's step 2, set the deck to RECORD mode. The output level at this point should be as follows : BAL : 20 ± 2 dBm (600 Ω load) UNBAL : 2 ± 0.5 V (10 k Ω load)
2. Record/play frequency response	Filter : OUT	BAL : 1 kHz, 20 dBm 10 Hz ~ 20 kHz, 20 dBm UNBAL : 1 kHz, 6 dBv 10 Hz ~ 20 kHz, 6 dBv	Check only	With the deck in the condition of step 1, when the input signal varies from 10 Hz to 22 kHz, the record/play frequency response with respect to the 1 kHz output level should be as follows : 20 Hz to 20 kHz ± 0.8 dB
3. Recording S/N ratio	Connection : Fig. 5-4 22 kHz LPF : IN IEC-A : IN	No input	Check only	With nothing input BAL or UNBAL INPUT, the S/N ratio with respect to the record/play output level in step 1 should be 88 dB or more.
4. Record/play dynamic range	Connection : Fig. 5-4 60 dB Amp. 400 Hz HPF : IN 30 kHz LPF : IN 22 kHz LPF : IN IEC-A : IN	BAL : 1 kHz, -40 dBm UNBAL : 1 kHz, -54 dBv	Check only	The distortion factor when the input signal is recorded with it lowered by 60 dB from the level in step 1 and played, should be 4.0 % or less and the dynamic range 88 dB or more.
5. Record/play channel separation	Connection : Fig. 5-4 22 kHz LPF : IN IEC-A : IN	BAL : 1 kHz, 20 dBm 10 kHz, 20 dBm UNBAL : 1 kHz, 6 dBv 10 kHz, 6 dBv (Input terminal of one channel should be grounded.)	Check only	When the deck is in the condition of step 1, the ratio between the output when a 1 kHz, 20 dBm (6 dBv) signal is input to one channel and the output at the other channel should be as follows : 1 kHz : 85 dB or more 10 kHz : 70 dB or more
6. Record/play distortion factor	Connection : Fig. 5-4 400 Hz HPF : IN 30 kHz LPF : IN 22 kHz LPF : IN	BAL : 100 Hz, 1 kHz, 10 kHz, 20 dBm UNBAL : 100 Hz, 1 kHz, 10 kHz, 6 dBv	Check only	0.01 % or less 0.08 % or less (LP mode)

## 5-3. オーディオ部確認

注意：確認の際はPCB Ass'yを取り付けている全てのネジを完全に取り付けた状態で行ってください。

### 1. 再生系

モード：PLAY（特に指示のある場合を除く）

テスト・テープ：SONY製 TY-7551

測定箇所：ANALOG OUTPUTS（BALANCED 又は UNBALANCED）

調整項目	準備・設定	入力信号	調整箇所	測定箇所・測定値
1. PB出力レベル	接続：図5-2	PGM NO.“1” 1kHz, 0dB	チェック	BAL : 20 ± 2dBm (600 Ω負荷) UNBAL : 2 ± 0.5V (10k Ω負荷)
2. 再生周波数特性	フィルター：OUT	PGM NO.“1” 1kHz PGM NO.“2” 20Hz PGM NO.“3” 100Hz PGM NO.“4” 10kHz PGM NO.“5” 20kHz	チェック	20Hz～20kHz ± 0.5dB
3. 再生歪率	接続：図5-3 400Hz HPF：IN 30kHz LPF：IN 22kHz LPF：IN	PGM NO.“1”～“5” 0dB	チェック	0.008%以下
4. 再生S/N	接続：図5-2 22kHz LPF：IN IEC-A：IN	PGM NO.“1” 1kHz, 0dB PGM NO.“6” -∞	チェック	PGM NO.“1” (0dB) を基準にし、 PGM NO.“6” (-∞) を再生したと きのS/N値は以下の通り。 95dB以上
5. 再生チャンネル間 セパレーション	接続：図5-2 22kHz LPF：IN IEC-A：IN	PGM NO.“7” 1kHz, L PGM NO.“8” 10kHz, L PGM NO.“9” 1kHz, R PGM NO.“10” 10kHz, R	チェック	再生基準出力に対して、 PGM NO.“7” (1kHz, L) → R PGM NO.“8” (10kHz, L) → R PGM NO.“9” (1kHz, R) → L PGM NO.“10” (10kHz, R) → L を再生したときのチャンネル間セパ レーションは以下の通り。 1kHz：90dB以上 10kHz：90dB以上

## 2. モニター系

モード：サンプリング・モニター又はREC・PAUSE

MONITORモード：UNCAL

Fs：48kHz

テスト・テープ：ブランク・テープ

調整項目	準備・設定	入力信号	調整箇所	測定箇所・測定値
1. LINE最小入力レベル	接続：図5-4 INPUTつまみ：MAX フィルター：OUT	BAL： 1kHz, 4dBm UNBAL： 1kHz, -10dBv (316mV)	チェック	入力信号レベルが、 $+4 \pm 2\text{dBm}$ (UNBAL： $-10 \pm 2\text{dBv}$ )の範囲の とき、レベル・メーターのOVERイ ンジケーターが点灯し始めるレベ ルがあること。
2. LINE基準入出力 レベル	接続：図5-4 INPUTつまみ：MIN フィルター：OUT	BAL： 1kHz, 20dBm UNBAL： 1kHz, 6dBv	INPUTつまみ	INPUTつまみを回し、レベル・メー ターのOVERインジケーターが点 灯直前になるようにセットする。 このときの出力レベルは、以下の 通りであること。 BAL： $20 \pm 2\text{dBm}$ (600 $\Omega$ 負荷) UNBAL： $2 \pm 0.5\text{V}$ (100k $\Omega$ 負荷)
3. モニター周波数特性	接続：図5-4 フィルター：OUT	BAL： 1kHz, 20dBm 20Hz~20kHz, 20dBm UNBAL： 1kHz, 6dBv 20Hz~20kHz, 6dBv	チェック	2項の出力レベルを 0dBとし、下記 のように周波数を変化させたとき の出力レベルを確認する。 20Hz~20kHz： $\pm 0.5\text{dB}$
4. レベル・メーター の確認		BAL： 20Hz~20kHz, 20dBm UNBAL： 20Hz~20kHz, 6dBv	チェック	3項チェックのとき、同時にレベ ル・メーターをチェックし、常に “0”のドットが点灯していること。
5. ヘッドホン出力レベル		BAL： 1kHz, 20dBm UNBAL： 1kHz, 6dBv	PHONESつまみ	2項チェックのとき、PHONESつま みを最大に回したときのヘッドホ ン出力レベルは、以下の値である こと。 $0.9\text{Vrms}$ 以上 (100mW/8 $\Omega$ )

### 3. 録音系

モード：RECモード → PLAYモード

テスト・テープ：ブランク・テープ

調整項目	準備・設定	入力信号	調整箇所	測定箇所・測定値
1. 録再出力レベル	接続：図5-4 フィルター：OUT	BAL： 1kHz, 20dBm UNBAL： 1kHz, 6dBv	チェック	2の2項の状態のとき、録音状態にする。このときの出力レベルは、以下の通りであること。 BAL： 20 ± 2dBm (600 Ω負荷) UNBAL： 2 ± 0.5V (10k Ω負荷)
2. 録再周波数特性	接続：図5-4 フィルター：OUT	BAL： 1kHz, 20dBm 10Hz~20kHz, 20dBm UNBAL： 1kHz, 6dBv 10Hz~20kHz, 6dBv	チェック	1項の状態、入力信号の周波数を10Hz~22kHzに変化させたとき、1kHzの出力レベルに対しての録再周波数特性は以下の通りであること。 20Hz~20kHz ± 0.8dB
3. 録再S/N	接続：図5-4 22kHz LPF：IN IEC-A：IN	無入力	チェック	BAL or UNBAL INPUTに入力無し状態で、1項の録再出力レベルに対してのS/N値は以下の通りであること。 88dB以上
4. 録再ダイナミック・レンジ	接続：図5-4 60dB Amp. 400Hz HPF：IN 30kHz LPF：IN 22kHz LPF：IN IEC-A：IN	BAL： 1kHz, -40dBm UNBAL： 1kHz, -54dBv	チェック	1項の状態から入力信号を60dB下げた状態で録音し、再生したときの歪率は以下の通りであること。 4.0%以下 (ダイナミック・レンジ 88dB以上)
5. 録再チャンネル・セパレーション	接続：図5-4 22kHz LPF：IN IEC-A：IN	BAL： 1kHz, 20dBm 10kHz, 20dBm UNBAL： 1kHz, 6dBv 10kHz, 6dBv (片チャンネルの入力端子は、GNDショート)	チェック	1項の状態、1kHz, 20dBm (6dBv)の入力信号を片チャンネルに加えたときの出力に対して、もう片チャンネルの出力との比は以下の通りであること。 1kHz: 85dB以上 10kHz: 70dB以上
6. 録再歪率	接続：図5-4 400Hz HPF：IN 30kHz LPF：IN 22kHz LPF：IN	BAL： 100Hz, 1kHz, 10kHz, 20dBm UNBAL： 100Hz, 1kHz, 10kHz, 6dBv	チェック	0.01%以下 0.08%以下 (LPモード)

# 6. EXPLODED VIEWS AND PARTS LIST

分解図とパーツリスト

EXPLODED VIEW-1

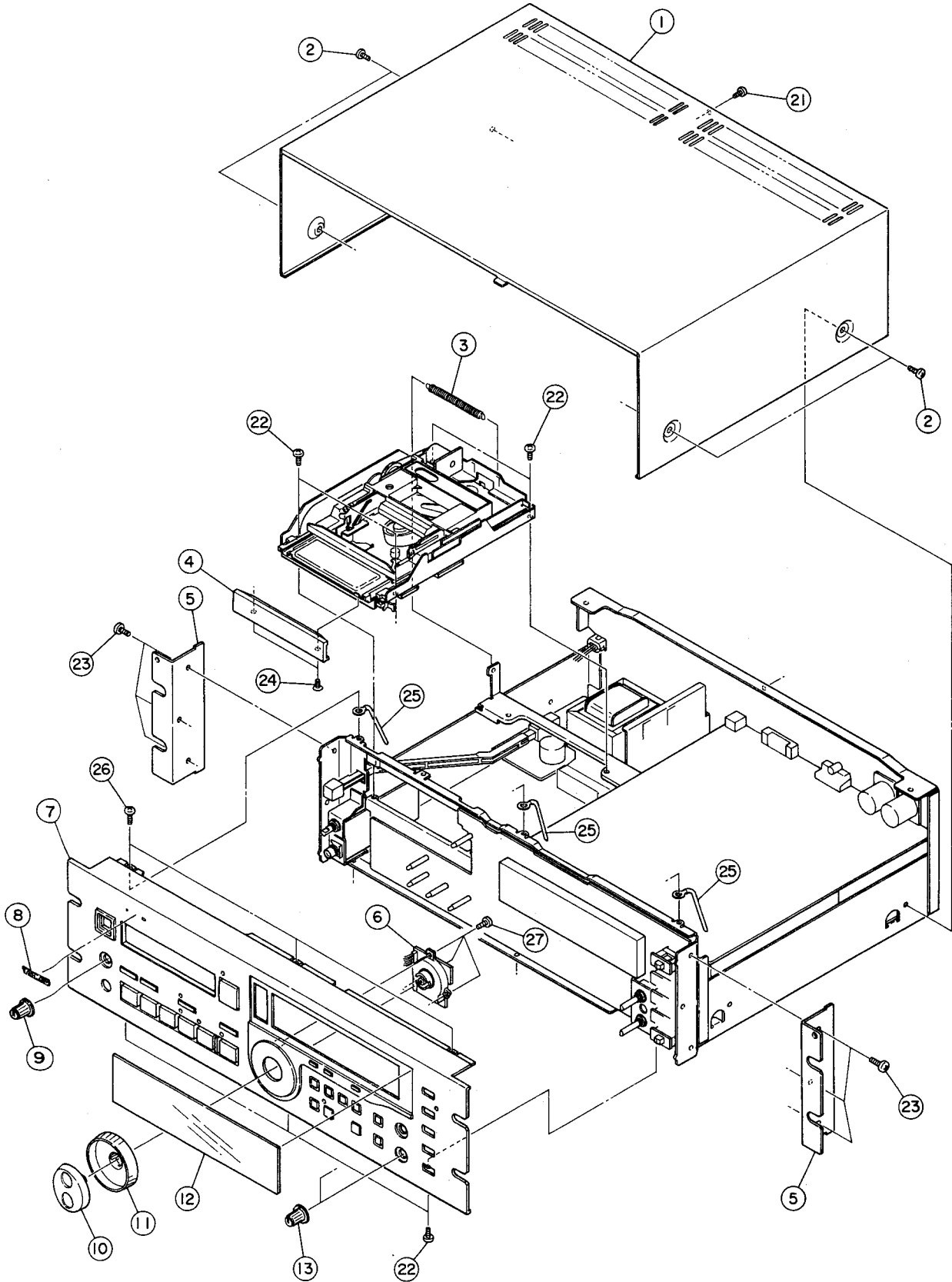

### EXPLODED VIEW -1

REF. NO.	PARTS NO.	DESCRIPTION	REMARKS
1- 1	*5801350900	BONNET, B	Refer to pages 42 and 46
1- 2	*5800612400	SCREW, BONNET M3X8	
1- 3	M00082900A	TNSN SPRING, TRAY	
1- 4	*M00000500A	COVER, TRAY B	
1- 5	*5801348701	ANGLE	
1- 6	*E95001800A	SHUTTLE PCB ASSY	
1- 7	*M00002800C	FRONT PNL ASSY, A[DA-30MK2]	
	*M00002900C	FRONT PNL ASSY, B[DA-25]	
1- 8		NAME PLATE, TASCAM(S)	
1- 9	M00002501A	KNOB, YB	
1-10	M00001800A	KNOB, JOG	
1-11	M00001900A	KNOB, SHUTTLE	
1-12	*M00001700B	WINDOW, DISPLAY	
1-13	M00002500A	KNOB, RB	
1-21	*5783613008	SCREW, C-TITE BRZ M3X8 (BLK)	
1-22	*5783033006	SCREW, BIND S-TITE M3X6	
1-23	*5783804008	SCREW, BIND C-TITE M4X8 (BLK)	
1-24	*5780222004	SCREW, FLAT M2X4 (BLK)	
1-25	*5786713000	CLIP, HARNESS 3. 0X9. 1X50	
1-26	*5783033008	SCREW, BIND S-TITE M3X8	
1-27	*5783543008	SCR, B P-TITE M3X8 (BLK)	

### EXPLODED VIEW -4 (Continued from page 39)

REF. NO.	PARTS NO.	DESCRIPTION	REMARKS
4-45	*V00012000A	LINK LDG BLK	
4-46	*V00011700A	SCREW, PAN M1. 7X3. 5	
4-47	V00017500A	ARM L1, (IN)	
4-48	*V00012200A	LINK LDG BLK	
4-49	V00017600A	ARM L1, (OUT)	
4-50	V00015000A	CYL ASSY	
4-51	V00017100A	SP TG-R	
4-52	*V00016000A	TG-R	
4-53	V00014600A	ROTOR BLK	
4-54	V00014900A	FRANGE CAP	
4-55	V00017700A	WORM WHEEL	
4-56	V00017800A	CENTER GEAR	
4-57	V00013300A	GEAR LDG BLK	
4-57-1	V00025600A	MOTOR, LOADING	
4-57-2	V00025700A	PULLEY, MOTOR	
4-57-3	V00025800A	GEAR ASSY	
4-58	V00013500A	BELT, LDG	
4-59	V00014800A	SENSOR BLK	
4-60	V00012700A	LEVER LDG BLK	
4-60-1	V00012800A	PINCH ROLLER	
4-61	*V00011800A	SCREW, PAN M1. 4X2. 5	
4-62	V00018500A	SOLENOID	
4-63	*V00015900A	BKT SOL	

EXPLODED VIEW-2

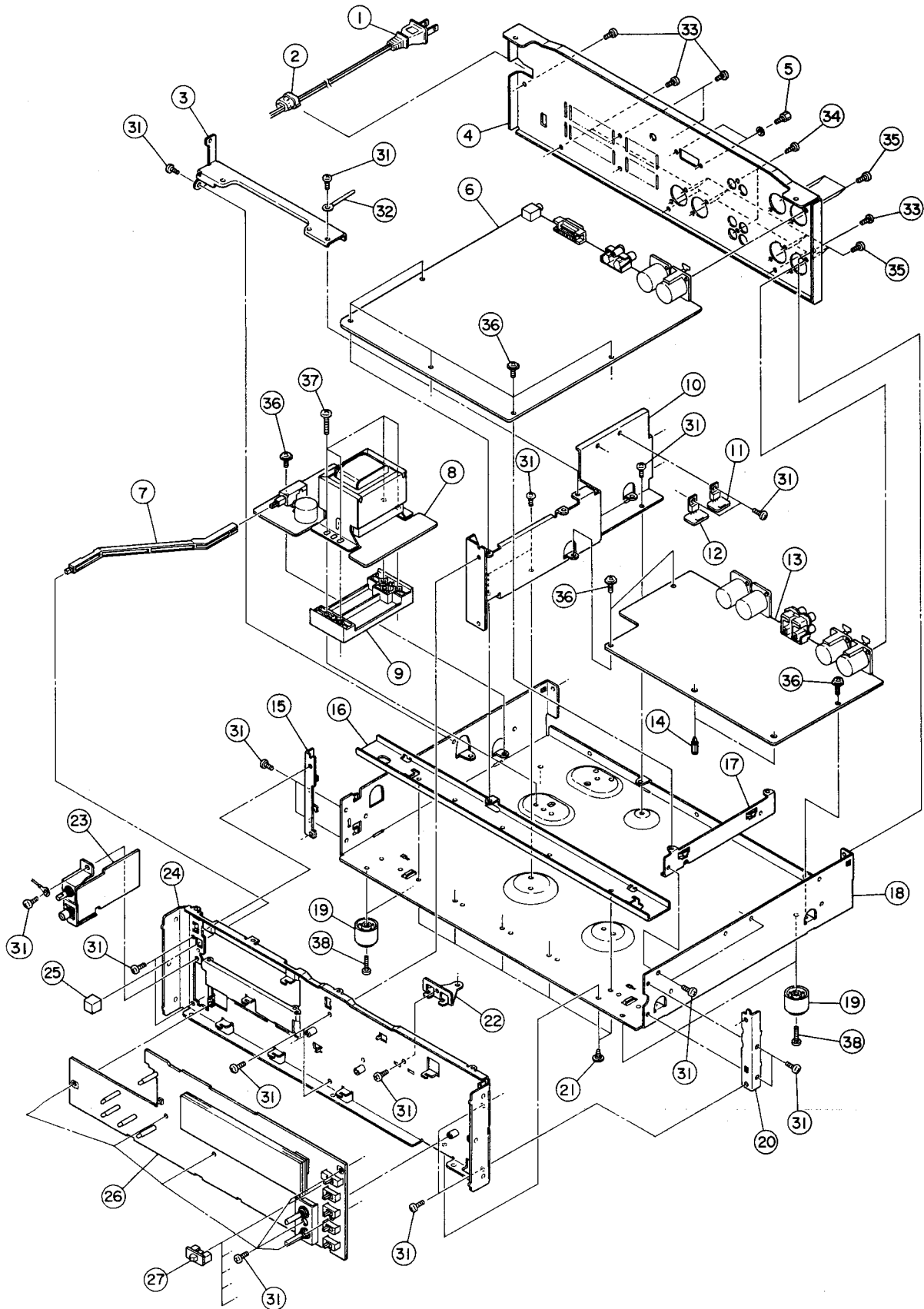



## EXPLODED VIEW -2

REF. NO.	PARTS NO.	DESCRIPTION	REMARKS
2- 1	△ 5350015600	CORD, AC DM [J]	
	△ 5350019300	CORD, AC UL SPT-2 [GE]	
	△ 5350017500	CORD, AC EUR CLASS 2 [E]	
	△ E00120800A	CORD, AC 5A [UK]	
	△ 5350018200	CORD, AC SAA [A]	
	△ 5350019500	CORD, AC UL/CSA SPT-2 [US/C]	
2- 2	△*5317003400	BUSHING, 2271	
2- 3	*M00000100A	BRACKET, MECH	
2- 4	*M00001200A	REAR PANEL, A [DA-30MK2 GE]	
	*M00001201A	REAR PANEL, B [DA-30MK2 J, US/C, E, UK, A]	
	*M00001202A	REAR PANEL, C [DA-25]	
2- 5	*5801536400	SCREW, DSUB LOCK M2. 6X0. 45	
2- 6	*E95002200B	DIGITAL/SERVO PCB ASSY [DA-30MK2]	Refer to pages 41 and 45
	*E95002201B	DIGITAL/SERVO PCB ASSY [DA-25]	Refer to pages 41 and 45
2- 7	*M00000800A	ROD, JOINT	
2- 8	*E95002000A	TRANS PCB ASSY [J]	Refer to pages 43 and 47
	*E95002011A	TRANS PCB ASSY [US/C]	Refer to pages 43 and 47
	*E95002030A	TRANS PCB ASSY [GE]	Refer to pages 43 and 47
	*E95002040A	TRANS PCB ASSY [E]	Refer to pages 43 and 47
	*E95002050A	TRANS PCB ASSY [UK, A]	Refer to pages 43 and 47
2- 9	*5801406000	BASE, TRANS.	
2-10	*M00000200A	FRAME, CENTER	
2-11	*E95002300A	REG 1 PCB ASSY	Refer to pages 44 and 47
2-12	*E95002400A	REG 2 PCB ASSY	Refer to pages 44 and 47
2-13	*E95001400A	AUDIO PCB ASSY [DA30-MK2]	Refer to pages 40 and 45
	*E95001401A	AUDIO PCB ASSY [DA-25]	Refer to pages 40 and 45
2-14	*5787030800	SUPPORT, PCB PS-8NS	
2-15	*M00000600A	BRACKET, FRONT CHAS A	
2-16	*M00000900A	BRACKET, CHAS ANGLE	
2-17	*5801531900	ANGLE, PCB	
2-18		CHASSIS, MAIN	
2-19	5504676000	FOOT, 19L	
2-20	*M00000700A	BRACKET, FRONT CHAS B	
2-21	*5801566100	SCREW, S-TITE STEPPED 3*6	
2-22	*M000083000A	BRACKET, PCB A	
2-23	*E95001500A	HEAD PHONES PCB ASSY	Refer to pages 42 and 46
2-24	*M00001000A	FRONT CHAS ASSY, DA3	
2-25	M00001500A	BUTTON, C	
2-26	*E95001700A	FRONT PCB ASSY [DA30-MK2]	Refer to pages 43 and 47
	*E95001701A	FRONT PCB ASSY [DA-25]	Refer to pages 43 and 47
2-27	M00001600A	KNOB, SLIDE	
2-31	*5783033006	SCREW, BIND S-TITE M3X6	
2-32	*5786713000	CLIP, HARNESS 3. 0X9. 1X50	
2-33	*5783693006	SCREW, B S-TITE M3X6 (BLK)	
2-34	*5783543008	SCREW, B P-TITE M3X8 (BLK)	
2-35	*5783613008	SCREW, B C-TITE M3X8 (BLK)	
2-36	*5783073006	SCREW, PAN S-TITE CAP M3X6	
2-37	*5780004018	SCREW, BIND M4X18	
2-38	*5783034020	SCREW, BIND S-TITE M4X20	

## EXPLODED VIEW-3

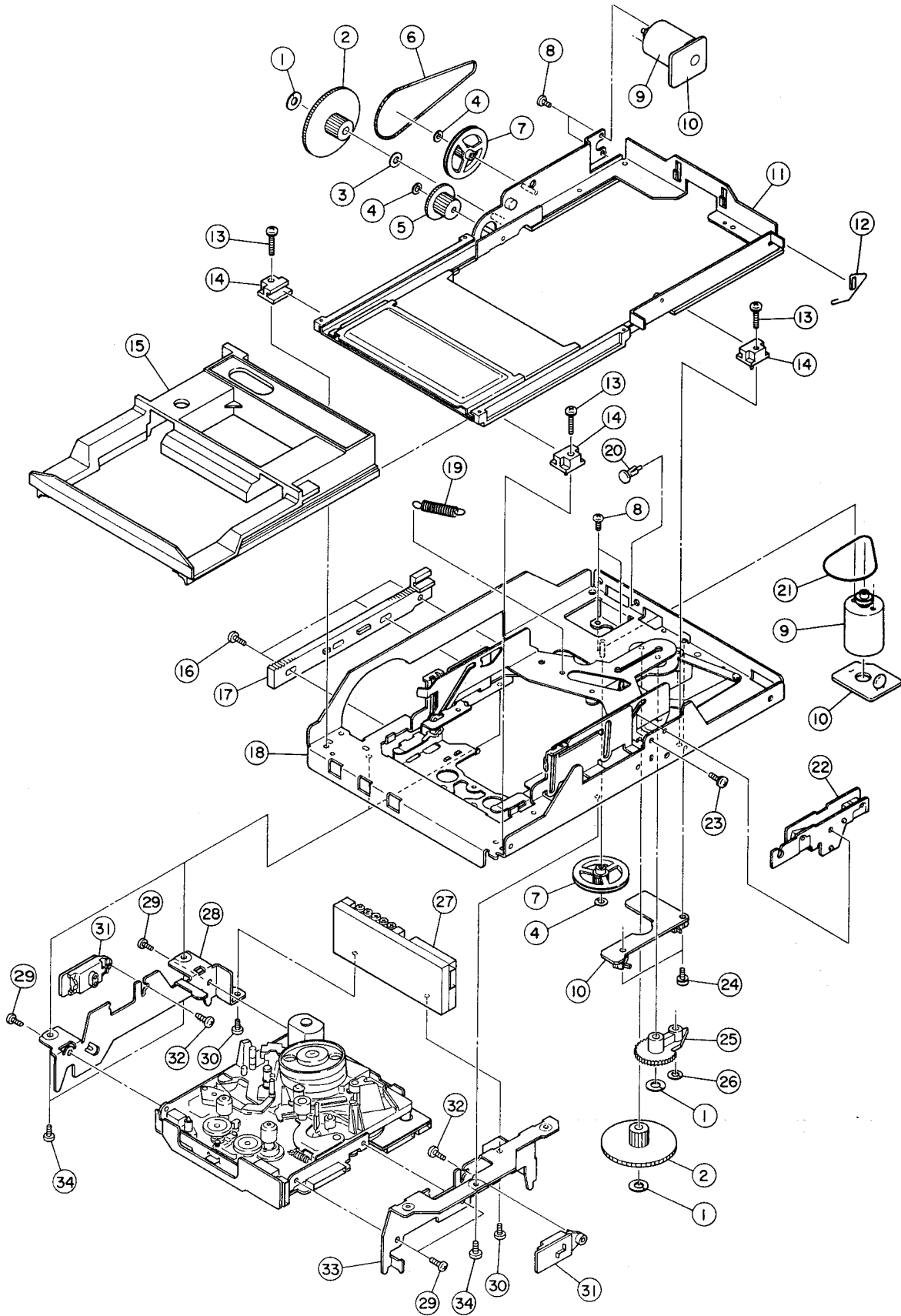

### EXPLODED VIEW -3

REF. NO.	PARTS NO.	DESCRIPTION	REMARKS
3- 1	5761817100	WASHER, LUMIRROR C 3.5X0.25	
3- 2	5761816800	GEAR DRIVE	
3- 3	V00020000A	WASHER, POLY. 4.1X0.25	
3- 4	5761688400	WASHER, LUMIRROR	
3- 5	5761819000	GEAR TIMING	
3- 6	5761818900	BELT DRIVE	
3- 7	5761816700	GEAR PULLEY	
3- 8	*5761815200	SCREW, PAN 2.0X2.0 NI	
3- 9	5761816600	MTR BLK	
3-10	*V00019800A	PCB CTL BLK	
3-11	V00019400A	HOLDER BLK	
3-12	*5761843200	WIRE GUIDE	
3-13	*5761819300	SCREW, PAN 2.6X10 ZN	
3-14	5761819100	BUSHING TRAY	
3-15	*5761819200	HOLDER CASSETTE	
3-16	*5761791800	SCREW, PAN 2.6X5 ZN	
3-17	5761819400	PACK GEAR	
3-18		HOLDER BASE BLK	
3-19	5761815800	SPRING	
3-20	*5761852100	PUSH RIVET	
3-21	5761817000	BELT DRIVE	
3-22	V00019900A	SENSOR BLK	
3-23	*5761817500	SCREW, PAN 2.0X5 ZN	
3-24	*5761817200	SCREW, PAN 2.0X8 ZN	
3-25	5761816900	GEAR CRANK	
3-26	*5761816000	WASHER, LUMIRROR C 2.6X0.25	
3-27	V00020700A	RF AMP BLK	
3-28	*V00020200A	SLIDE PLATE, (L)	
3-29	*5761813600	SCREW, PAN TT 2.0X4 ZN	
3-30	*5761813000	SCREW, BIND 2.0X2.5 ZN	
3-31	V00020300A	SENSOR BLK	
3-32	*5761689500	SCREW, WAVE 2X6	
3-33	*V00020100A	SLIDE PLATE, (R)	
3-34	*V00020800A	SCREW, PAN TT M2.6X5	

### INCLUDED ACCESSORIES

REF. NO.	PARTS NO.	DESCRIPTION	REMARKS
	Y00014700A	REMOTE CONTROL UNIT, RC-D30 [J]	
	*D00006400A	OWNERS MNL, E DA-30MK2 [US/C, GE, E, UK, A]	
	*D00006300A	OWNERS MNL, J DA-30MK2/25[J]	
	*5780315015	SCREW, OVAL M5X15(NI)	
	*5801512200	WASHER, ROSETTE 5X12X3	
	*5785225000	WASHER, FIBER 5X10X0.5T	

EXPLODED VIEW-4

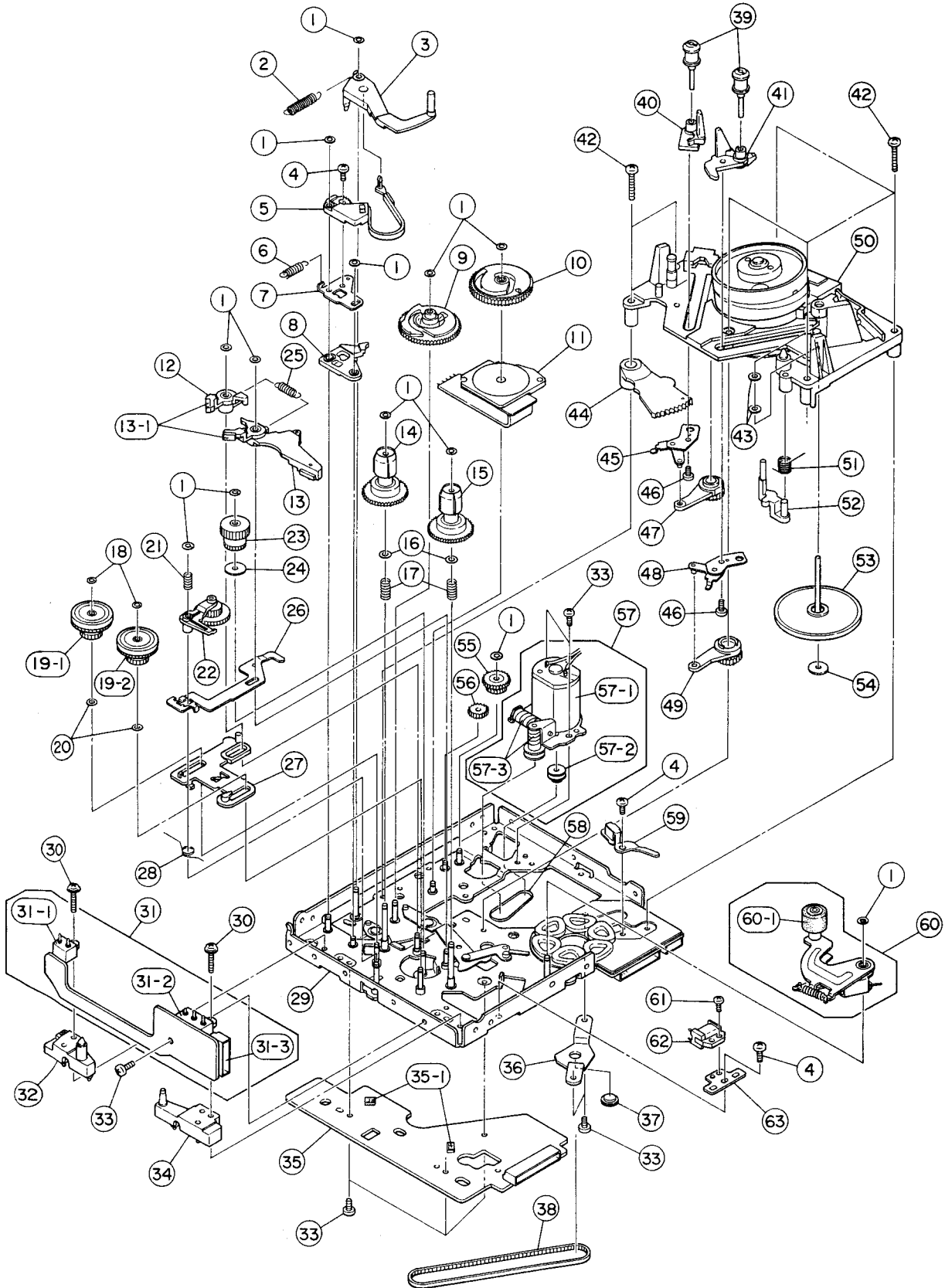

## EXPLODED VIEW -4

REF. NO.	PARTS NO.	DESCRIPTION	REMARKS
4- 1	V00011400A	WASHER, LUMIRROR	
4- 2	V00016800A	SP BT	
4- 3	V00016100A	ARM BT	
4- 4	*V00011900A	SCREW, PAN M1. 7X2. 5	
4- 5	V00018600A	BAND BT ASSY	
4- 6	V00016900A	SP LEVER BT	
4- 7	*V00015800A	LEVER BT	
4- 8	V00016300A	LEVER CAM BT	
4- 9	V00017300A	CAM MODE	
4-10	V00018000A	GEAR MODE	
4-11	V00018800A	SW MODE	
4-12	V00018700A	ARM SU BRAKE	
4-13	V00013200A	LEVER LDG BLK	
4-13-1	V00025900A	PAD, BRAKE	
4-14	V00018200A	REEL ASSY	
4-15	V00018300A	REEL ASSY	
4-16	*5761839400	WASHER, POLY 2. 1X0. 25	
4-17	V00017200A	SP SU REEL	
4-18	5761806200	WASHER, LUMIRROR C 0. 9X0. 25	
4-19-1	V00018100A	TU ASSY	
4-19-2	V00019000A	TU ASSY	
4-20	5761806000	WASHER, POLY 1. 4X0. 25	
4-21	V00016600A	SP IDLE	
4-22	V00018400A	GEAR IDLE	
4-23	V00017900A	PULLEY CENTER	
4-24	5761839400	WASHER, POLY, 2. 1X0. 25	
4-25	V00016700A	SP BRAKE	
4-26	*V00015600A	PLATE CAM	
4-27	*V00016200A	CAM IDLE	
4-28	V00017000A	SP PLATE CAM	
4-29	V00012400A	CHASSIS BASE BLK	
4-30	*5761690100	SCREW, TAPTITE	
4-31	*V00013600A	SENSOR BLK	
4-31-1	5761812900	SWITCH, SPPW52	
4-31-2	5761813100	SWITCH, SPPW53	
4-31-3	V00013800A	CONNECTOR, S8B-ZR	
4-32	*V00016400A	SPACER ID, (L)	
4-33	*5761813600	SCREW, PAN TT 2. 0X4 ZN	
4-34	*V00016500A	SPACER ID, (R)	
4-35	*V00013900A	SENSOR BLK	
4-35-1	V00014100A	SENSOR, GP2S04	
4-36	*V00015700A	BKT CAP	
4-37	5761690600	SCREW, WHEEL RETAINING	
4-38	V00019200A	BELT CAP	
4-39	V00014500A	ROLLER GUIDE	
4-40	V00014300A	BASE INC IN	
4-41	V00014400A	BASE INC OUT	
4-42	*V00011600A	SCREW, PAN M1. 7X10	
4-43	*V00011500A	WASHER, LUMIRROR 1. 4X0. 25	
4-44	V00017400A	ARM GEAR	

(Continued on page 33)

# 7. PC BOARDS AND PARTS LIST

基板図とパーツリスト

## AUDIO PCB ASSY

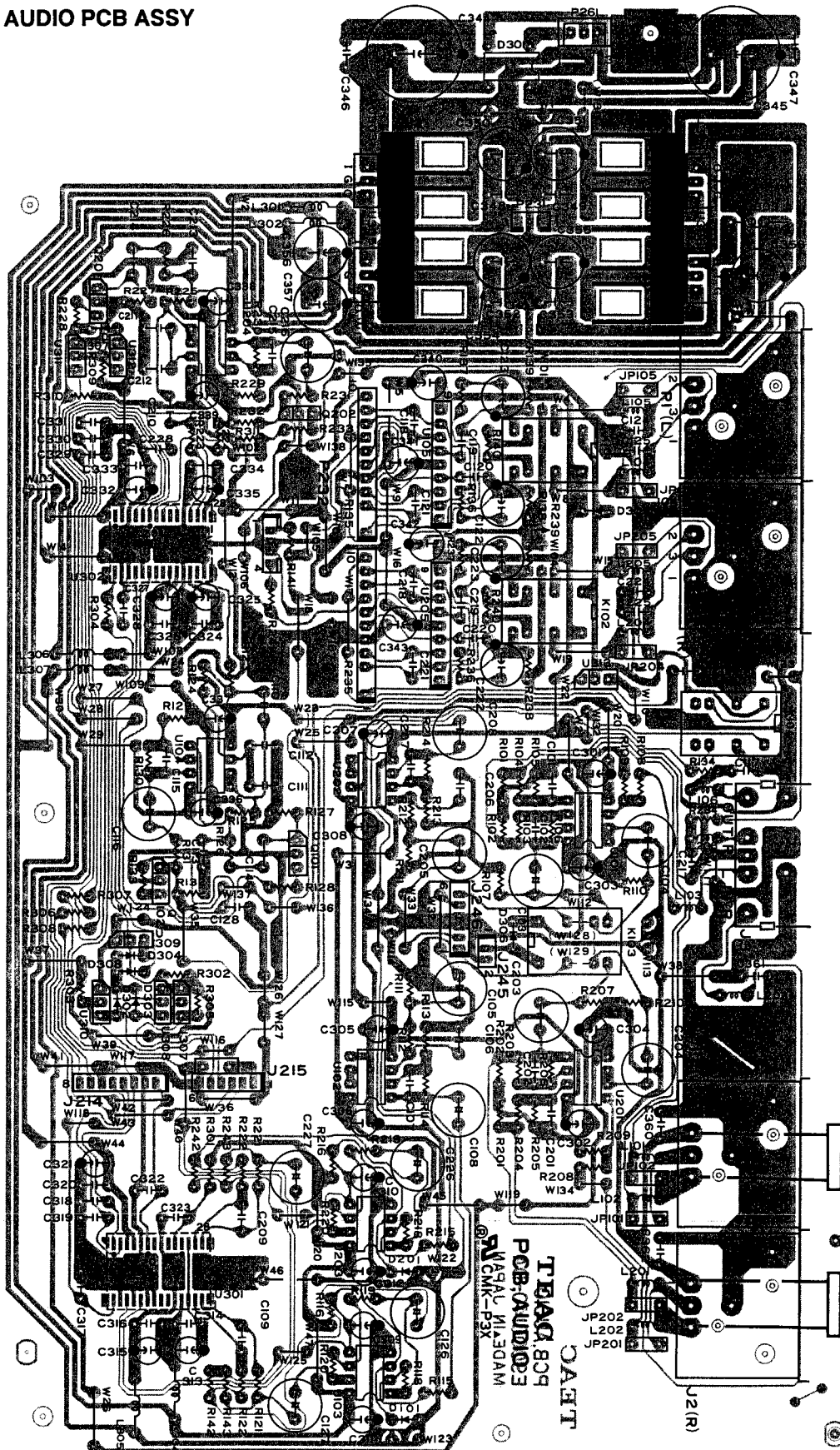

# DA-30MKII/DA-25

DIGITAL/SERVO PCB ASSY

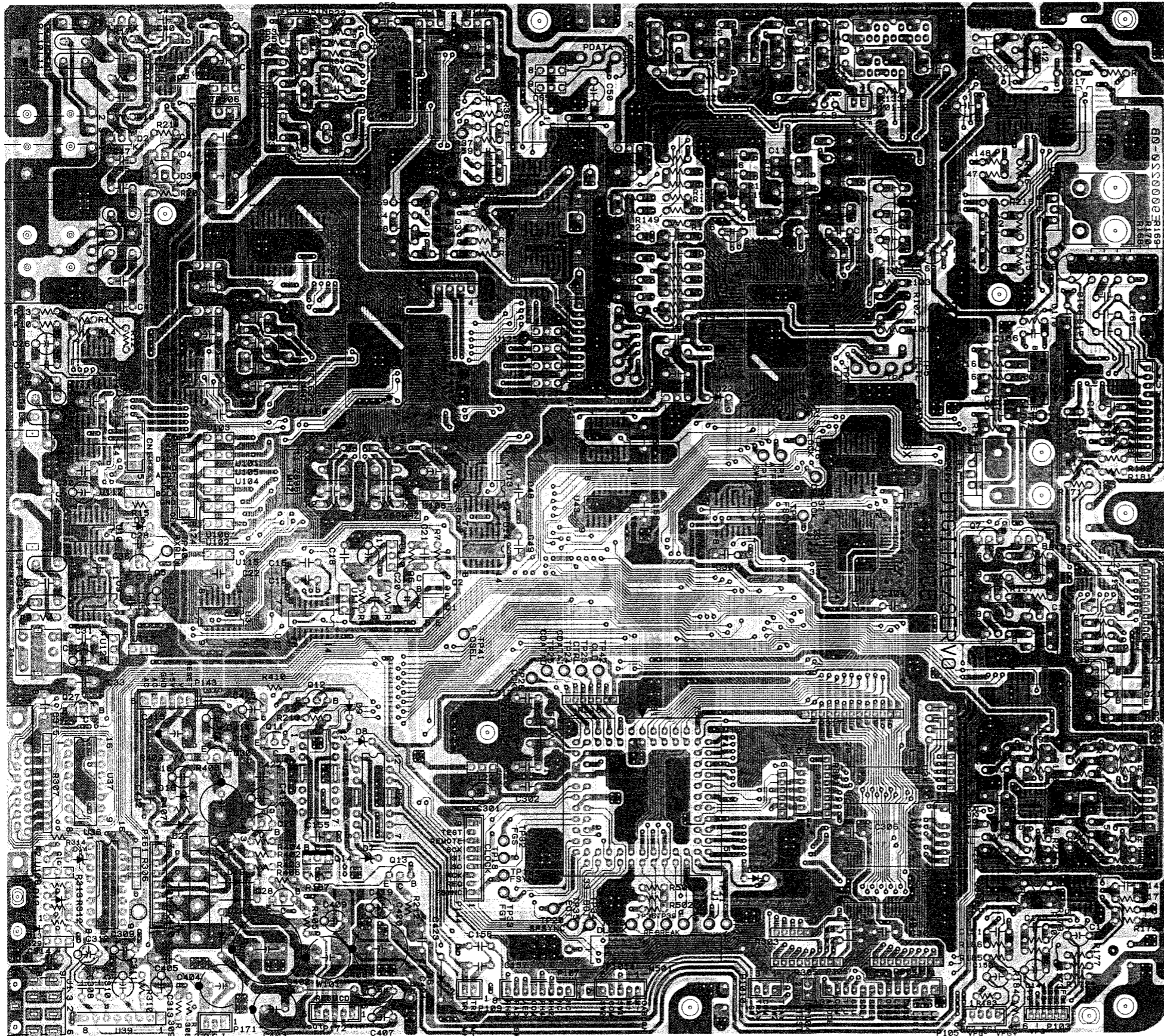

HEAD PHONES PCB ASSY

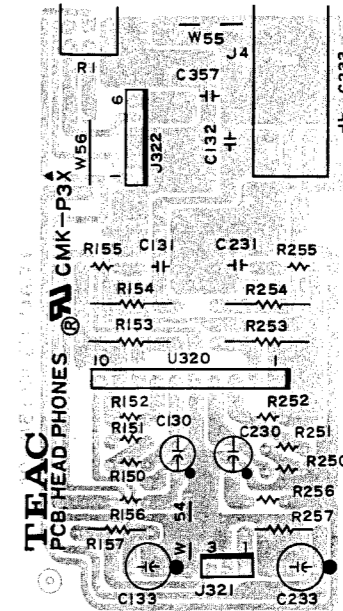

SHUTTLE PCB ASSY

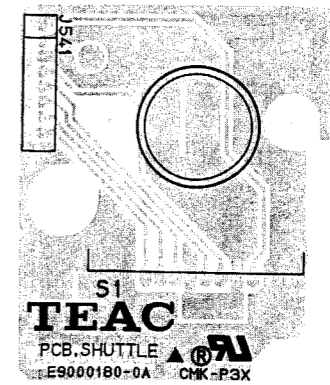

FRONT PCB ASSY

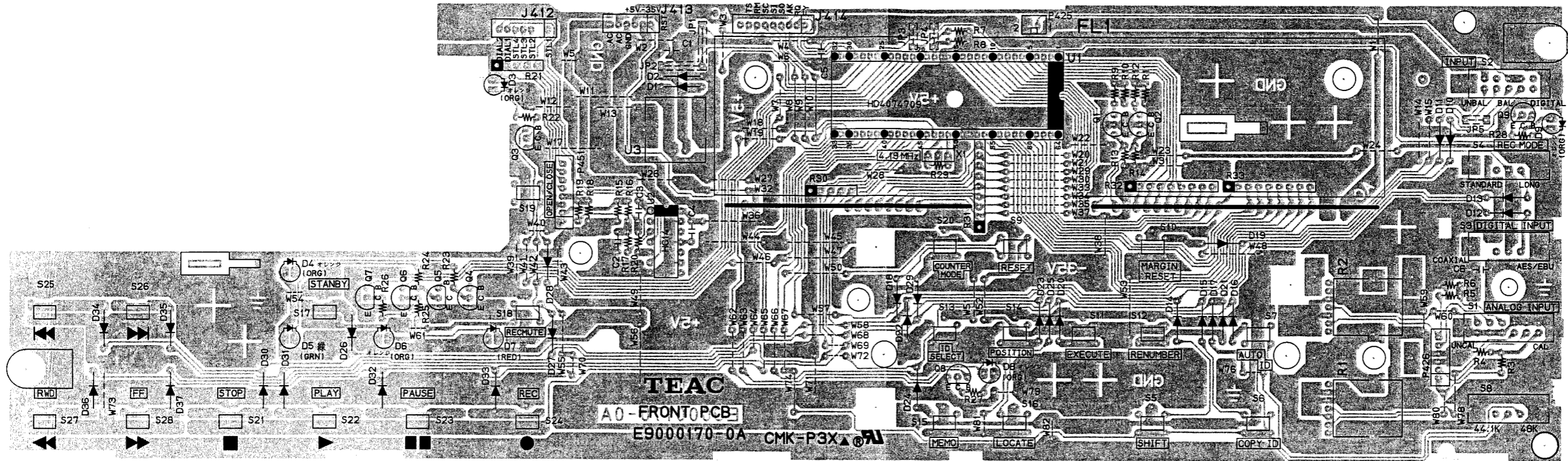

TRANS PCB ASSY

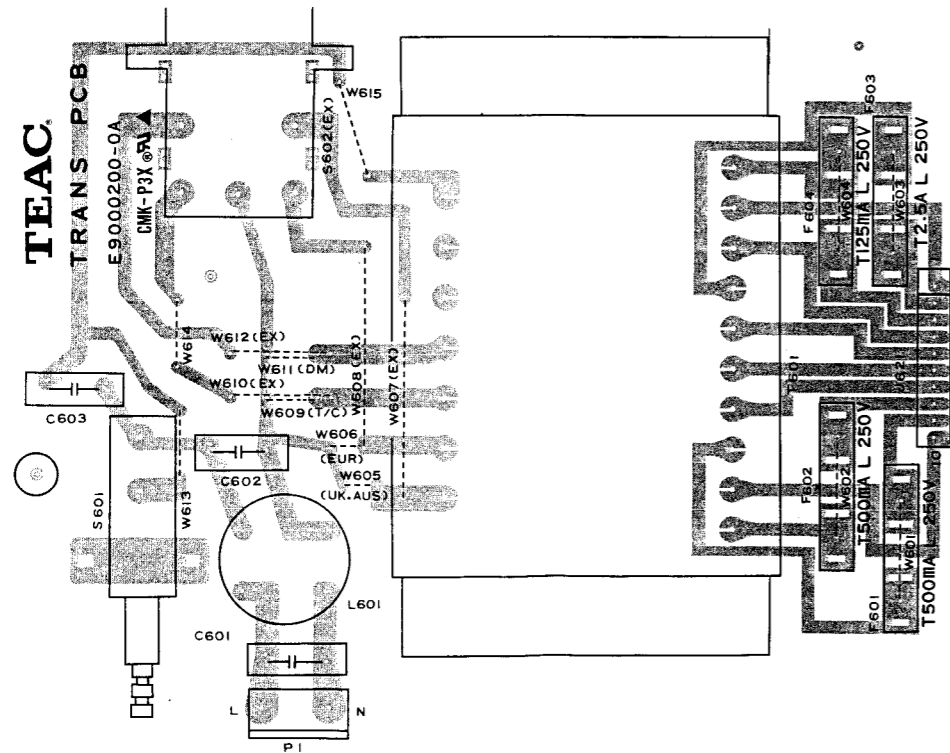

REG 1 PCB ASSY

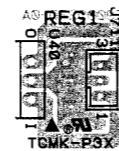

REG 2 PCB ASSY





## AUDIO PCB ASSY

REF. NO.	PARTS NO.	DESCRIPTION
	*E95001400A	AUDIO PCB ASSY[DA-30MK2]
	*E95001401A	AUDIO PCB ASSY[DA-25]
	*E90001400A	AUDIO PCB
C344, 345	△ 5260476910	HEAT SINK, OSH-1625-SP C, ELEC. 3300UF 25V
C346, 347	△ 5173433000	C, CERAMIC 0.010UF 50V
D101, 201	S0014781	D, ZENER RD2. 4HS
D301	△ 5228010700	SILICON STACK, S1WB(A)20
D302-304	5224015020	D, 1SS133T-77 FT
D305, 306	5224015020	D, 1SS133T-77 FT[DA-30MK2]
D307, 308	5224015020	D, 1SS133T-77 FT
J1, 2	E0000450	CONNECTOR, XLB3-31PCV-M01 [DA-30MK2]
J3	E0000430	JACK, PIN 4P YKC21-3049
K101, 103	5290012700	RELAY, 12V G5A-237PL[DA-30MK2]
K104	5290012700	RELAY, 12V G5A-237PL
L101, 102	5347022720	FERRITE BEAD, EXC ELDR35V [DA-30MK2]
L103, 106	5347022720	FERRITE BEAD, EXC ELDR35V
L104, 105	5347022720	FERRITE BEAD, EXC ELDR35V [DA-30MK2]
L201, 202	5347022720	FERRITE BEAD, EXC ELDR35V [DA-30MK2]
L203, 206	5347022720	FERRITE BEAD, EXC ELDR35V
L204, 205	5347022720	FERRITE BEAD, EXC ELDR35V [DA-30MK2]
L301-303	5286033920	COIL, CHOKE 10UH
L304-307	5286034720	COIL, CHOKE 47UH
P1, 2	E0000440	CONNECTOR, XLB3-32PCV-M01 [DA-30MK2]
P231	5336249300	PLUG, CONN. B03B-PH-K-S(WHT)
P232	5336249400	PLUG, CONN. B04B-PH-K-S(WHT)
P261	5336303300	PLUG, CONN. B3B-EH(WHT)
Q101, 201	5231762520	TR, 2SD1915TA
Q102, 202	5231762520	TR, 2SD1915TA
R135, 235	5242117800	R. ARRAY RMN Z8178[DA-30MK2]
U101, 201	5220431800	IC, NE5532AN
U102, 202	5220431800	IC, NE5532AN
U103, 203	S0000170	IC, NJM2100D
U104, 204	5220431800	IC, NE5532AN
U105, 205	5220431100	IC, NJM5532S[DA-30MK2]
U301	S0000223	IC, AK-5340-VS
U302	S0000233	IC, AK-4328-VS
U303	△ 13447956	IC, NJM7812FA
U304	△ 13447973	IC, NJM7912FA
U305	△ 13447952	IC, NJM7805FA
U306	△ 13447969	IC, NJM7905FA
U307, 308	5232254720	TR, DTA114ES
U309-311	5232255620	TR, DTC114ES
U312	5232254720	TR, DTA114ES
U313	5232255920	TR, DTC143XS

## DIGITAL/SERVO PCB ASSY

REF. NO.	PARTS NO.	DESCRIPTION
	*E95002200B	DIGITAL/SERVO PCB ASSY [DA-30MK2]
	*E95002201B	DIGITAL/SERVO PCB ASSY[DA-25]
	*E90002200B	DIGITAL/SERVO PCB
	5730021000	HEAT SINK, OSH-1625-SP
C401	△ 12908842	C, CC 50V 0.1UF
C402	△ 5260428110	C, ELEC. 4700UF 16V
C410	△ 12907113	C, CC 25V 22000PF
C413	△ 5260424910	C, ELEC. 220UF 50V
D1-4	5224018020	D, MC932[DA-30MK2]
D5	5224015020	D, 1SS133T-77 FT
D6	5224013210	D, DS135 D FA4 FF
D7, 8	5224572201	DIODE, ZENER RD3. 6EL2 FR
D9	5224573201	DIODE, ZENER RD5. 1EL2 FR
D10-13	5224015020	D, 1SS133T-77 FT
D14	5224571801	D, ZENER RD3. 0EL2 FR
D15	5224580201	D, ZENER RD39EL1 FR
D16	5224574701	D, ZENER RD8. 2EL2 FR
D17	△ 5228013400	SILICON STACK, D3SBA20
D18-21	△ 5224013200	D, DS135 D FR
D22, D23	5224015020	D, 1SS133T-77 FT
J1	5330016100	JACK, 3P
J2	E0007380	JACK, YKC21-3044
J3	E0000440	CONNECTOR, XLB3-32PCV-M01 [DA-30MK2]
L1	5286033320	COIL, CHOKE 3.3UH
L2, 3	5286030200	COIL, CHOKE 47UH
L4	5286033520	COIL, CHOKE 4.7UH
L5-8	5347022720	FERRITE BEAD, EXC ELDR35V
L9-14	5347022720	FERRITE BEAD, EXC ELDR35V [DA-30MK2]
P1	E0000450	CONNECTOR, XLB3-31PCV-M01 [DA-30MK2]
P2	5334079900	SOCKET, CONN. 15P DSUB
P101-1	5336249900	PLUG, CON. B09B-PH-K-S(WHT)
P101-2, P109	5336249200	PLUG, CON. B02B-PH-K-S(WHT)
P102	13124433	CONNECTOR, ZH B 11B-ZR
P103	13124428	CONNECTOR, ZH B 6B-ZR
P104	5336250100	PLUG, CON. B11B-PH-K-S(WHT)
P105	5336249400	PLUG, CON. B04B-PH-K-S(WHT)
P106	5336250300	PLUG, CON. B13B-PH-K-S(WHT)
P107	5336249800	PLUG, CON. B08B-PH-K-S(WHT)
P108	5336249600	PLUG, CON. B06B-PH-K-S(WHT)
P124	5336249800	PLUG, CON. B08B-PH-K-S(WHT)
P125	5336251600	PLUG, CON. B06B-PH-K-R(RED)
P142	5336249700	PLUG, CON. B07B-PH-K-S(WHT)
P143	5336249600	PLUG, CON. B06B-PH-K-S(WHT)
P144	5336249900	PLUG, CON. B09B-PH-K-S(WHT)
P161	5336303700	PLUG, CON. B7B-EH(WHT)
P171	5336249300	PLUG, CON. B03B-PH-K-S(WHT)
P172	5336249500	PLUG, CON. B05B-PH-K-S(WHT)
P1010	5336249300	PLUG, CON. B03B-PH-K-S(WHT)
P1011	5336249500	PLUG, CON. B05B-PH-K-S(WHT)
Q1, Q2	13427337	TR, 2SC2412K

# DA-30MKII/DA-25

## DIGITAL/SERVO PCB ASSY

REF. NO.	PARTS NO.	DESCRIPTION
Q3, Q4	5230782500	TR, 2SC2620C TL
Q5-13	5232255820	TR, DTC144ES
Q14	5231762600	TR, 2SD1221Y
Q15-18	13427337	TR, 2SC2412K
Q19, Q20	5230509700	TR, 2SB1274R
Q21-23	5230020200	TR, 2SA1314B-TE12L, C
Q27	5232255620	TR, DTC114ES
Q28	5232255720	TR, DTC124ES
Q29	5230780920	TR, 2SC2603 F
Q30	△ 5145085000	TR, 2SA934 R
Q31	5232255620	TR, DTC114ES
R33	5280021300	VR, 10KB
R34	5280021700	VR, 47KB
R102	5280022100	VR, 220KB
R121	5280021300	VR, 10KB
R301	5242123200	R. ARRAY, RYLS-7J223
R302, 303	5242122900	R. ARRAY, RYLS-4J223
R304, 305	5242119100	R. ARRAY, RYLS8J103
R306	5242121800	R. ARRAY, RYLS-4J103
R307	5242118900	R. ARRAY, RMLS 8J223
R316	5242123000	R. ARRAY, RYLS-5J223
R317	5242117600	R. ARRAY, RYLS12J223
R318	5242123100	R. ARRAY, RYLS-6J223
TP1-30	5317002100	PIN, DH CHECK IPS-1136
TP101-103	5336303200	PLUG, CONN. B2B-EH
TP104	5336249200	PLUG, CONN. B02B-PH-K-S
TP105	5336303400	PLUG, CONN. B4B-EH
T1	5320046300	TRANS., PULSE TC-1027-04
U1	5220101600	IC, HD49226AFS-T
U2	5220094400	IC, HM65256BLF-12TT
U3	5220101300	IC, YM3437C-F [DA-30MK2]
U4	5220093700	IC, TC74HC08AF-TP2
U5, 6	5220093500	IC, TC74HC04AF-TP2
U7	5220093600	IC, TC74HC04AF-TP2
U8	5220093300	IC, TC74HC00AF-TP2
U9	5220093600	IC, TC74HC04AF-TP2
U10	5220093300	IC, TC74HC00AF-TP2
U11	5220094300	IC, MC34050MEL [DA-30MK2]
U12	5220444600	IC, SN74LS624NS-ELS
U13	5220102200	IC, TC74HC125AF-TP2
U14	5220093500	IC, TC74HC04AF-TP2
U15	5220101800	IC, HD49229
U16	5220093300	IC, TC74HC00
U17	5220101700	IC, HD49228FS-T
U18	5220444300	IC, UPC324G2 (MS)-E2
U20	5220102900	IC, TC74HC4053AF-TP2
U22, 23	5220444500	IC, UPC393G2 (MS)-E2
U24	5220094100	IC, TC4069UBF-TP2
U25, 26	5220430200	IC, LB1649
U27	5220448400	IC, TA7745F-TP2
U28	5220448900	IC, LB1851M
U29, 30	5220444400	IC, UPC358GR-E2
U31	S00155500A	IC, HD6473388CP10
U31	E0000750	SOCKET, PLCC PLPS-N84B-T
U32	5220126300	IC, UPD71054GB-10

## DIGITAL/SERVO PCB ASSY

REF. NO.	PARTS NO.	DESCRIPTION
U33, 34	13443331	IC, 82C55AFP-2
U35	5220093300	IC, TC74HC00AF-TP2
U36	5220093500	IC, TC74HC04AF-TP2
U37	13442774	IC, SN74LS147N
U38	13441784	IC, SN74LS145N
U39	5220430900	IC, 1R3T21
U42	5220093300	IC, TC74HC00AF-TP2
U44	5220444400	IC, UPC358GR-E2
U101-106	5292808020	FILTER, EMI 100PFT
U107-110	5292808620	FILTER, EMI 10000PFT
U112, 113	5292808620	FILTER, EMI 10000PFT
U114, 115	5292808620	FILTER, EMI 10000PFT [DA-30MK2]
U116, 117	5292808620	FILTER, EMI 10000PFT
U118-119	5292807920	FILTER, EMI 47PFT
U120-122	5292808620	FILTER, EMI 10000PFT
U123-126	5292808020	FILTER, EMI 100PFT
U127-129	5292807920	FILTER, EMI 47PFT
U130	5292809800	FILTER, LOW-PASS (PILOT)
U131	5292809900	FILTER, BANDPASS (SYNC)
X1	5347017000	OSC, CRYSTAL 37.632MHZ
X2	5347017200	OSC, CRYSTAL 11.2896MHZ
X3	5347017100	OSC, CRYSTAL 12.288MHZ
X4	E0000510	RESONATOR, HC-49/U 20.0MHZ

## HEAD PHONES PCB ASSY

REF. NO.	PARTS NO.	DESCRIPTION
	*E95001500A	HEAD PHONES PCB ASSY
	*E90001500A	HEAD PHONES PCB
	5801581400	BRACKET B, H. P
J4	5330012600	JACK, 3P FJ332DB-M
R1	R0000040	VR, 1S2UVR9 20KX2
R153, 253	△ 5180018000	R, CARBON R50 2.2 OHM
R154, 254	△ 5180044000	R, CARBON R50 27 OHM
R157, 257	△ 5183554000	R, INCOMB. F25 10 OHM
U320	5220438700	IC, LA6510

## SHUTTLE PCB ASSY

REF. NO.	PARTS NO.	DESCRIPTION
	*E95001800A	SHUTTLE PCB ASSY
	*E90001800A	SHUTTLE PCB
S1	E0000460	ENCODER, SRGPHJ

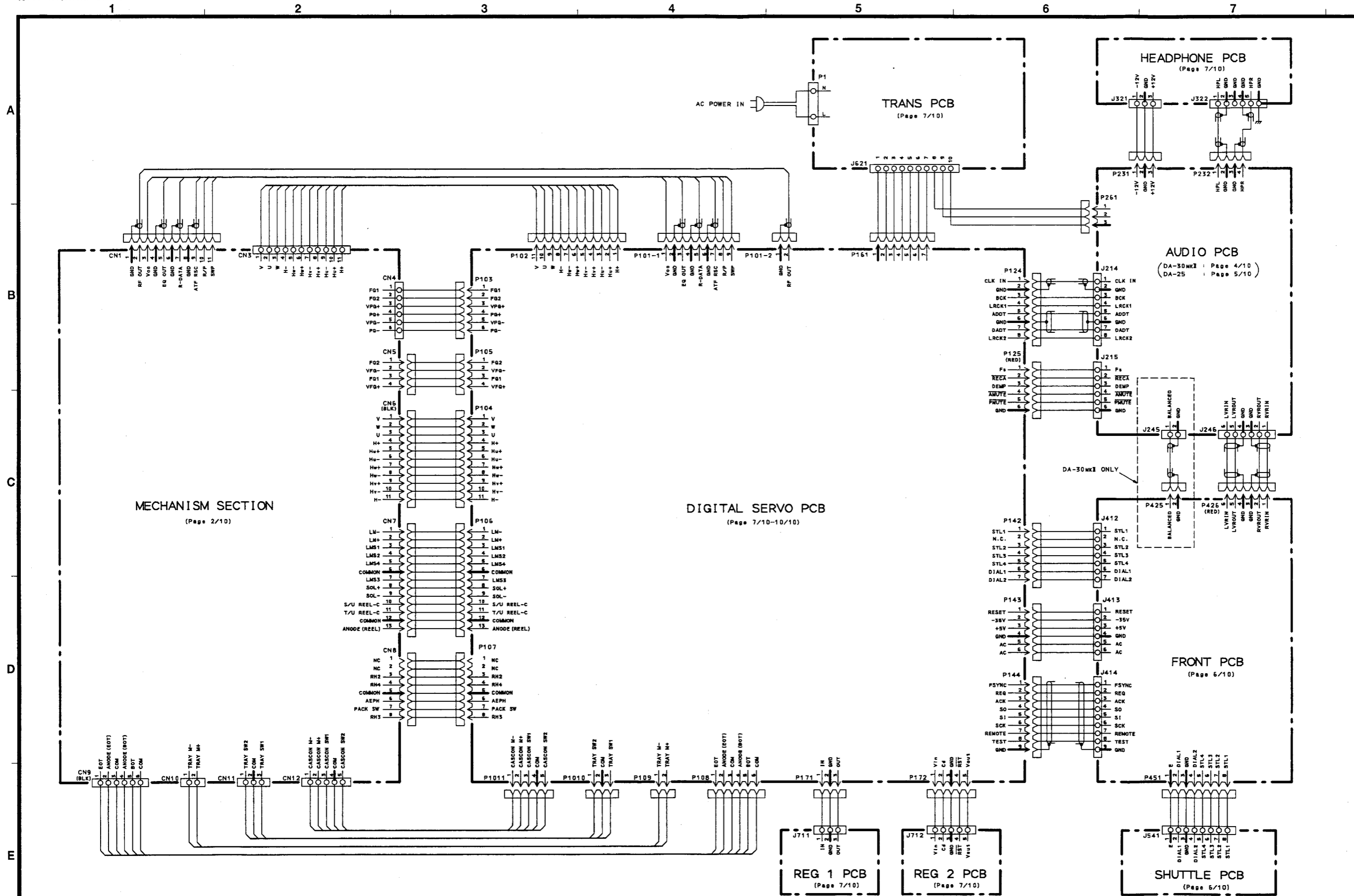

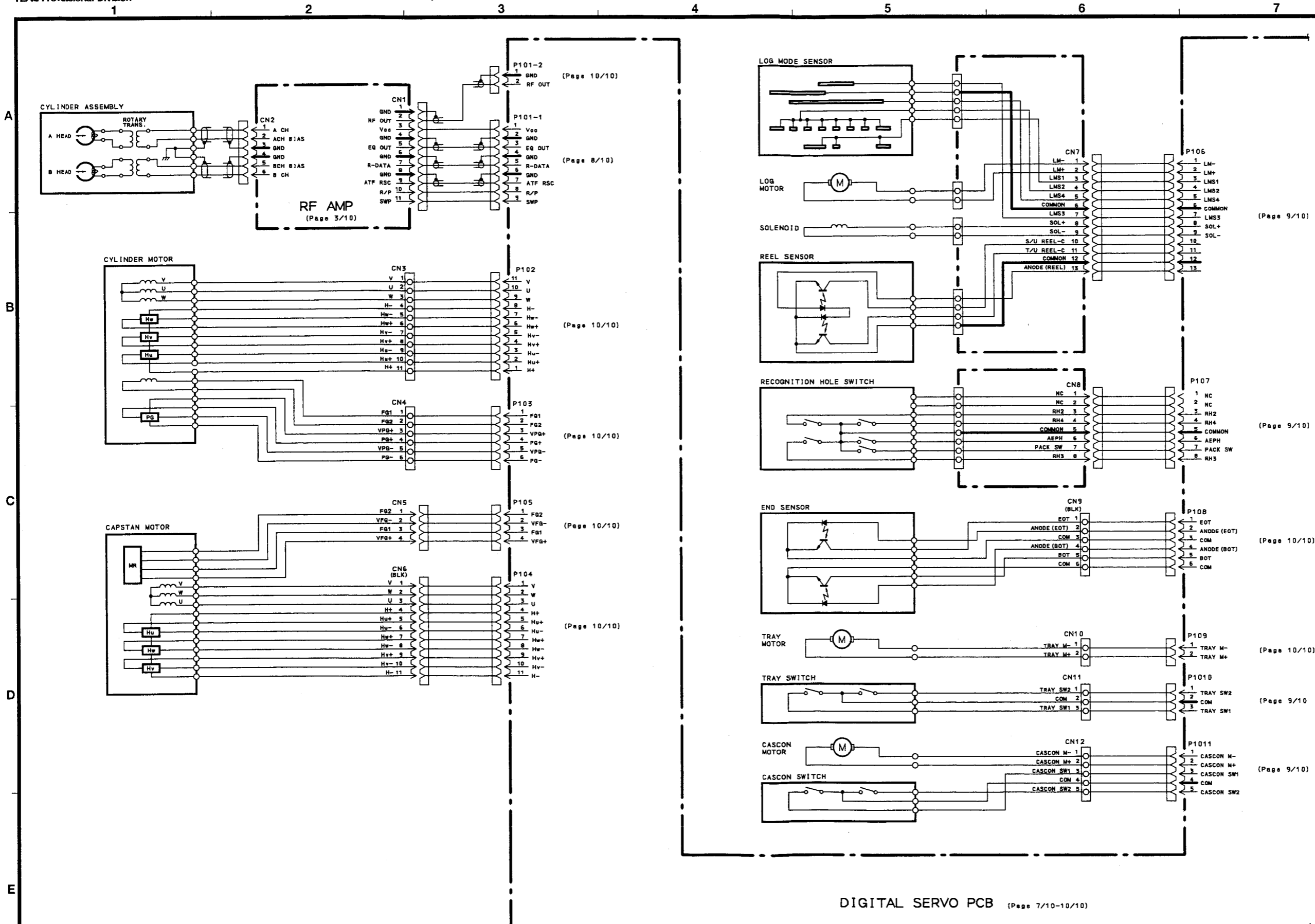

A  
B  
C  
D  
E

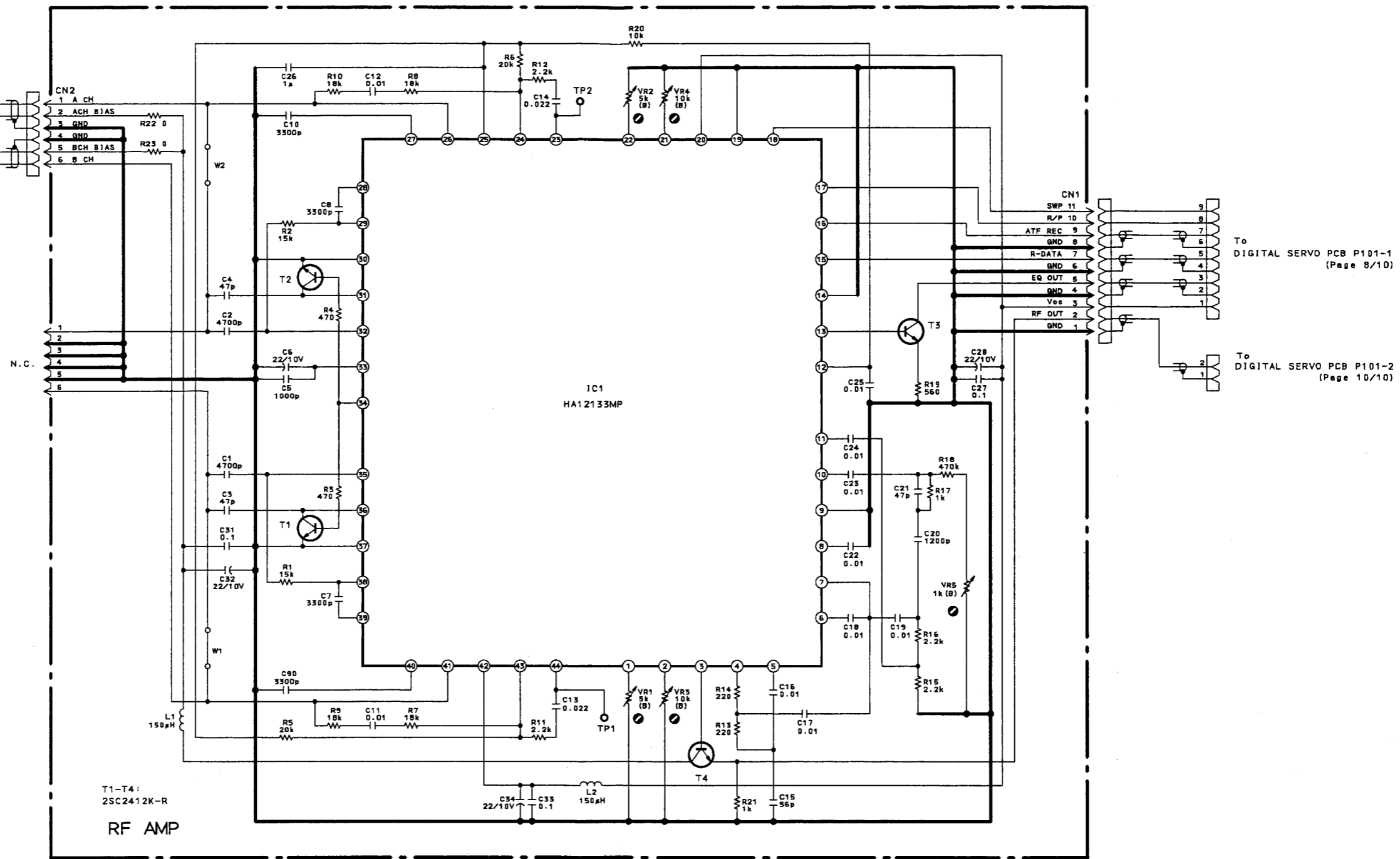
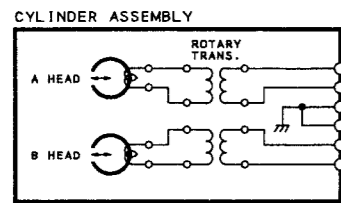

To DIGITAL SERVO PCB P101-1  
(Page 8/10)

To DIGITAL SERVO PCB P101-2  
(Page 10/10)

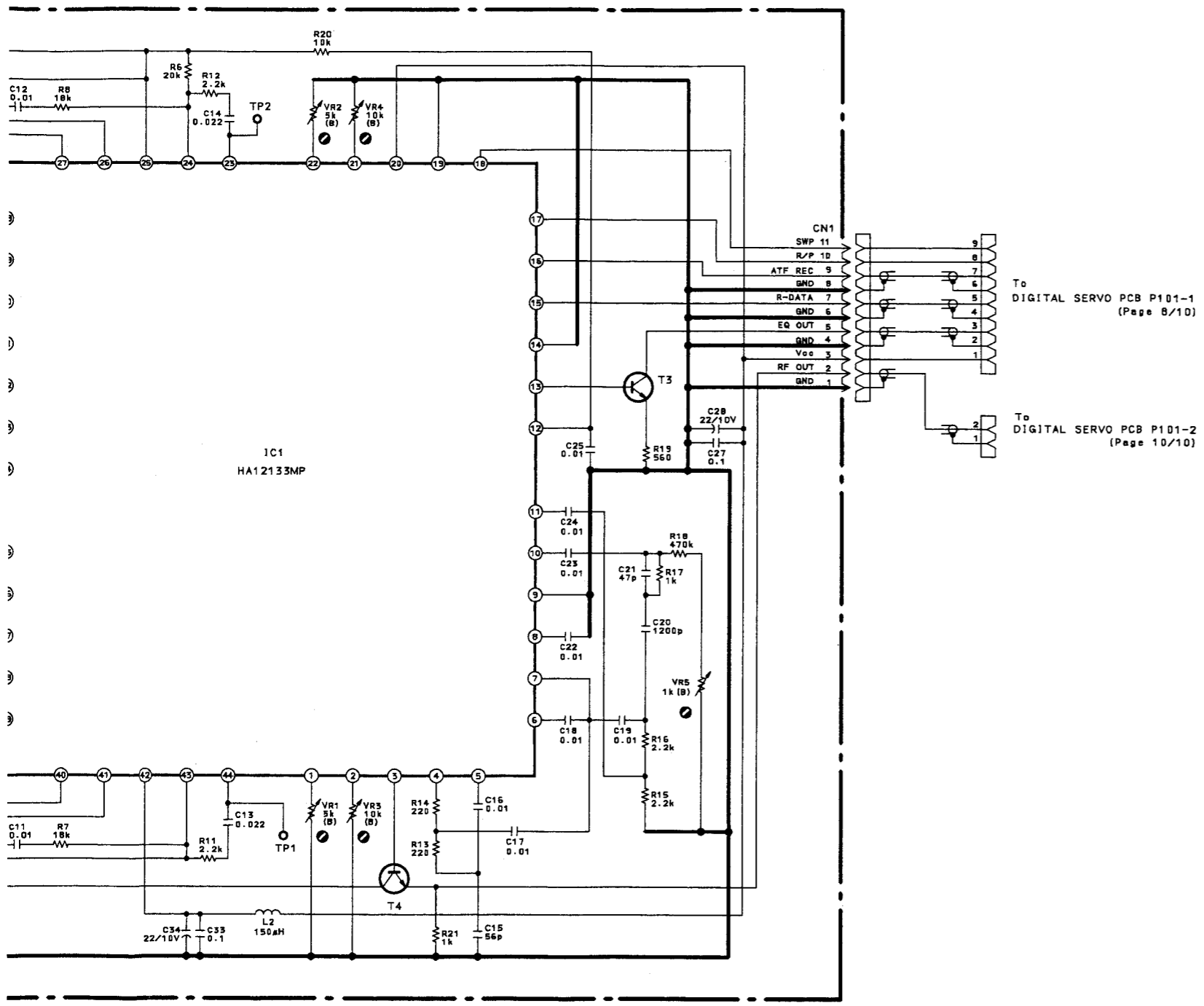



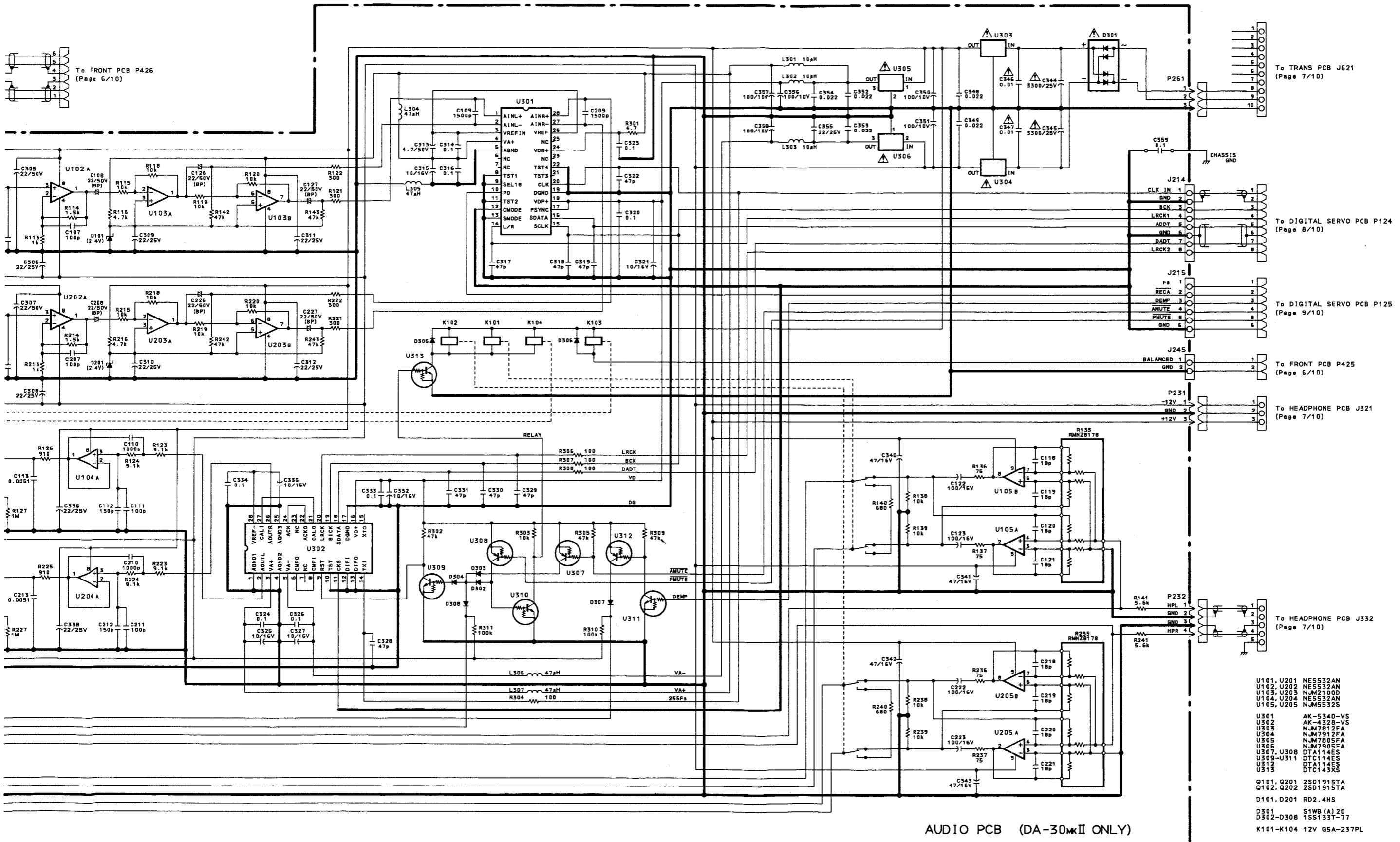

To FRONT PCB P426  
(Page 6/10)

To TRANS PCB J621  
(Page 7/10)

To DIGITAL SERVO PCB P124  
(Page 8/10)

To DIGITAL SERVO PCB P125  
(Page 9/10)

To FRONT PCB P425  
(Page 6/10)

To HEADPHONE PCB J321  
(Page 7/10)

To HEADPHONE PCB J332  
(Page 7/10)

- U101, U201 NES532AN
- U102, U202 NES532AN
- U103, U203 NJM2100D
- U104, U204 NES532AN
- U105, U205 NJM532S
- U301 AK-5340-VS
- U302 AK-4320-VS
- U303 NJM7812FA
- U304 NJM7912FA
- U305 NJM7805FA
- U306 NJM7905FA
- U307, U308 DTA114ES
- U309-U311 DTC114ES
- U312 C2A114ES
- U313 DTC143XS
- Q101, Q201 2SD1915TA
- Q102, Q202 2SD1915TA
- D101, D201 RD2.4HS
- D301 S1WB(A)20
- D302-D308 1SS1331-77
- K101-K104 12V G5A-237PL

AUDIO PCB (DA-30MKII ONLY)

# Digital Audio Tape Deck DA-30MK2



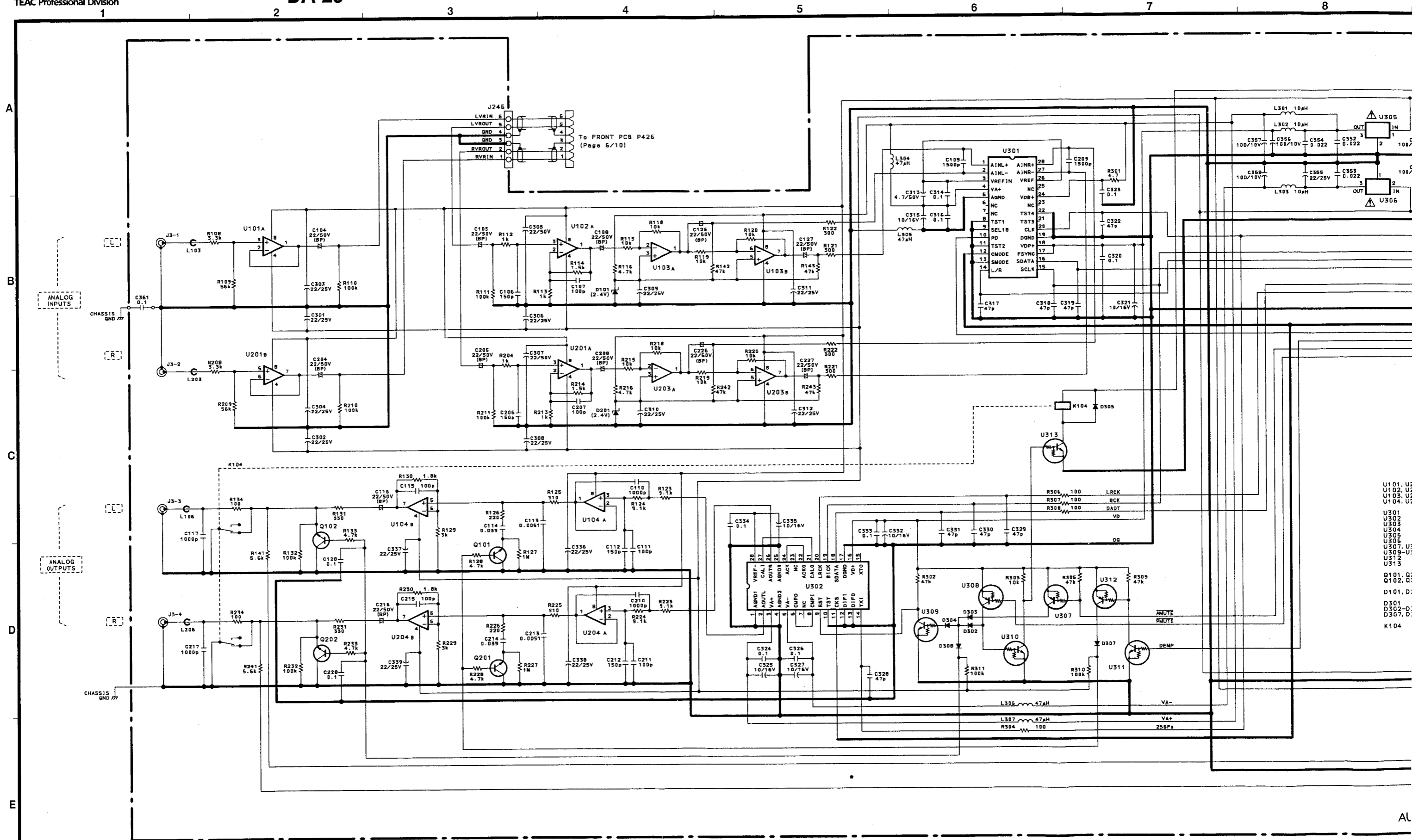

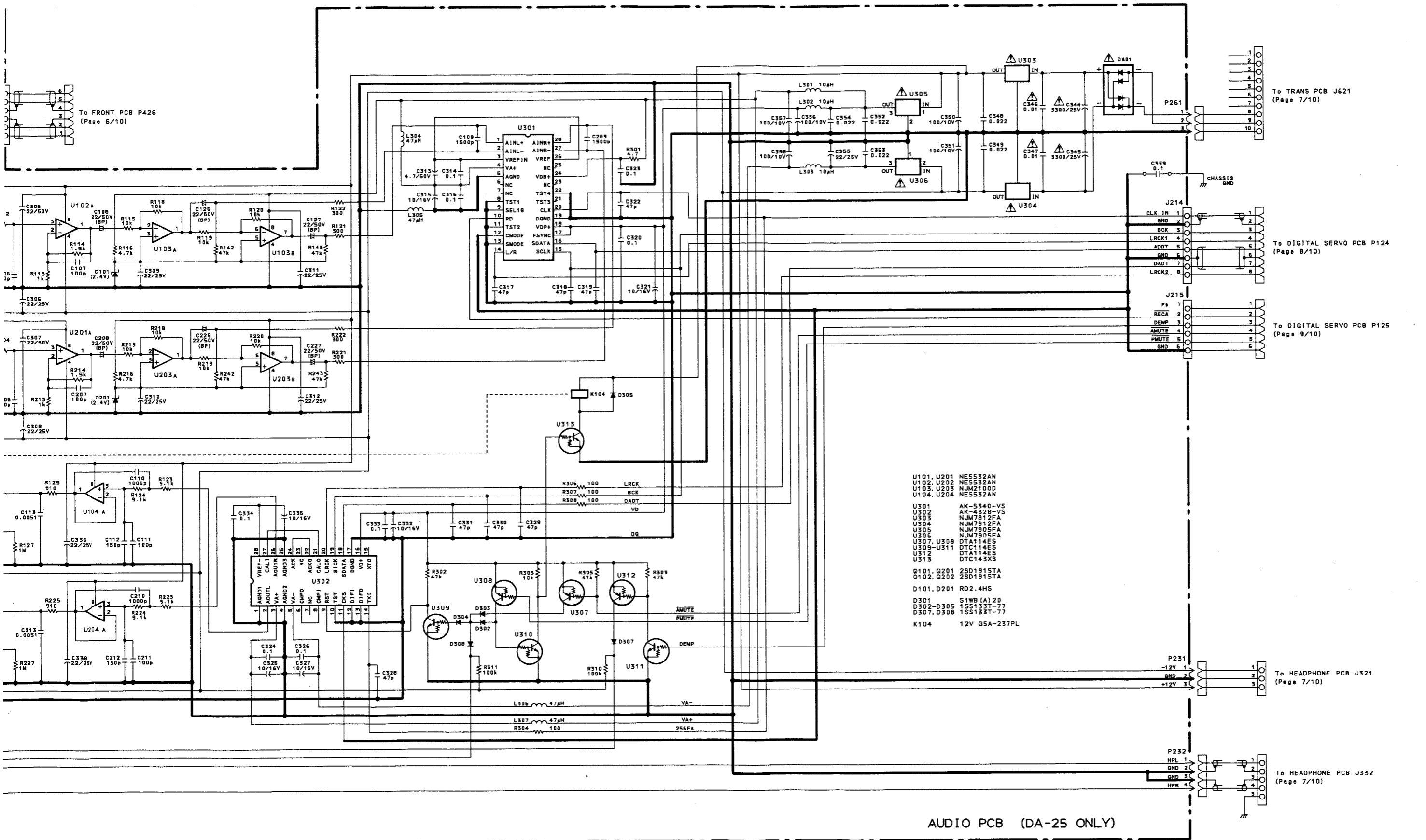

- U101, U201 NE5532AN
- U102, U202 NE5532AN
- U103, U203 NJM2100D
- U104, U204 NE5532AN
- U301 AK-5340-VS
- U302 AK-4328-VS
- U303 NJM7812FA
- U304 NJM7912FA
- U305 NJM7805FA
- U306 NJM7905FA
- U307, U308 DTA114ES
- U309-U311 DTC114ES
- U312 DTA114ES
- U313 DTC143XS
- Q101, Q201 2SD1915TA
- Q102, Q202 2SD1915TA
- D101, D201 RD2.4HS
- D301 S1WB (A) 2D
- D302-D305 1SS5331-77
- D307, D308 1SS1331-77
- K104 12V G5A-237PL

AUDIO PCB (DA-25 ONLY)

# Digital Audio Tape Deck DA-25

1 2 3 4 5 6 7 8

A  
B  
C  
D  
E

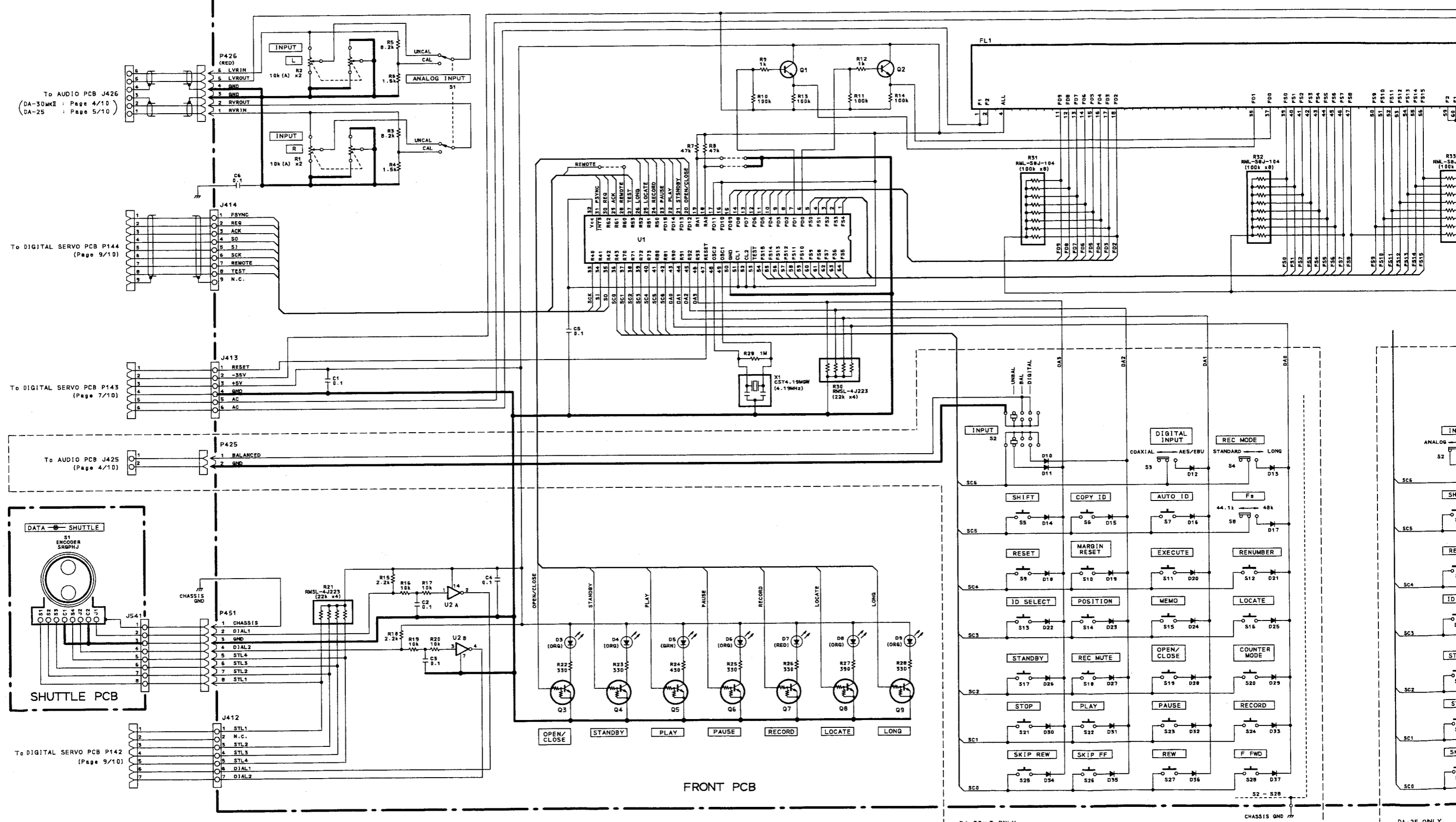

To AUDIO PCB J426  
(DA-30MK2 : Page 4/10)  
(DA-25 : Page 5/10)

To DIGITAL SERVO PCB P144  
(Page 9/10)

To DIGITAL SERVO PCB P143  
(Page 7/10)

To AUDIO PCB J425  
(Page 4/10)

To DIGITAL SERVO PCB P142  
(Page 9/10)

DA-30MK2 ONLY

CHASSIS GND

DA-25 ONLY

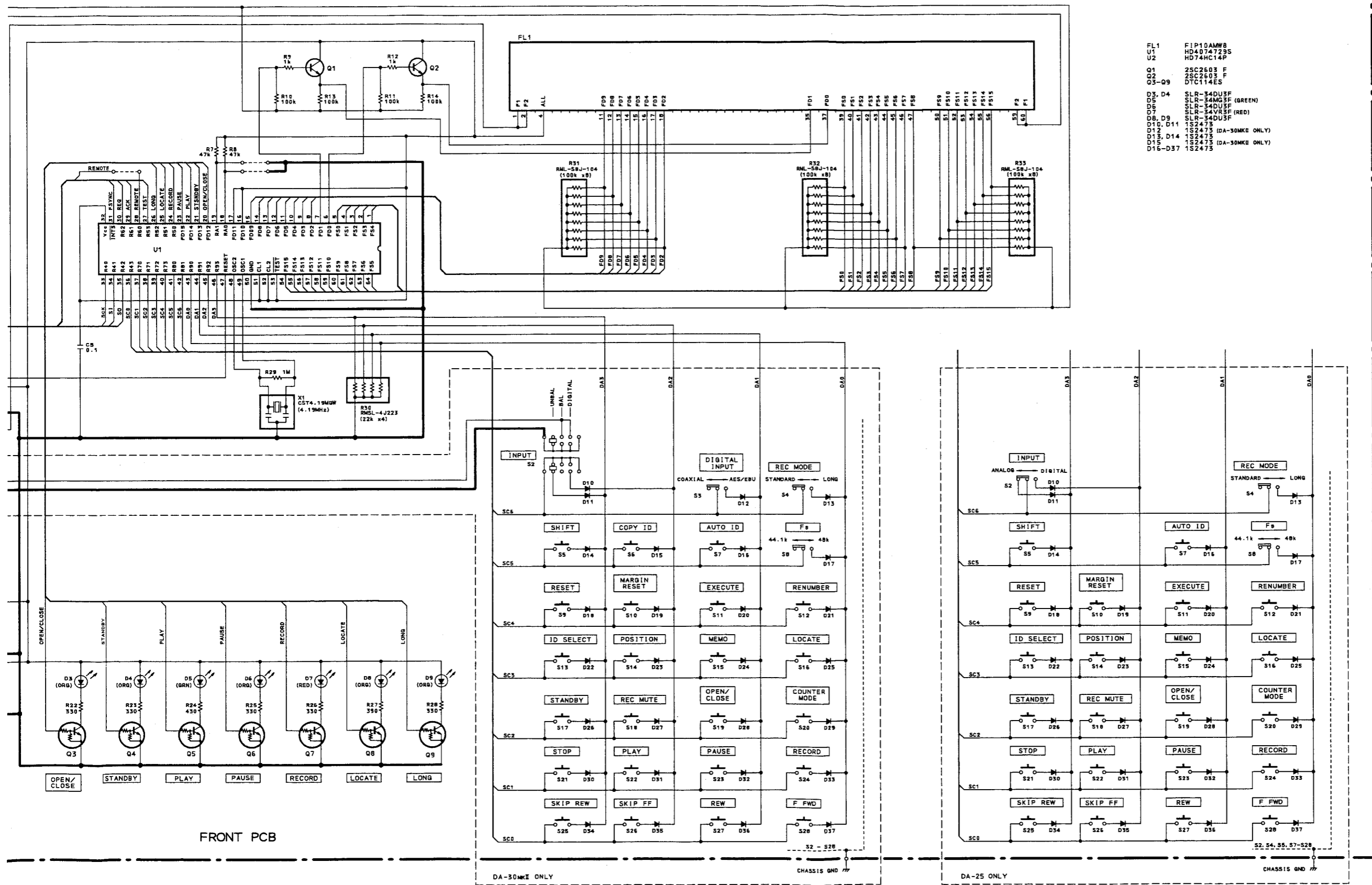

# Digital Audio Tape Deck DA-30MK2/DA-25

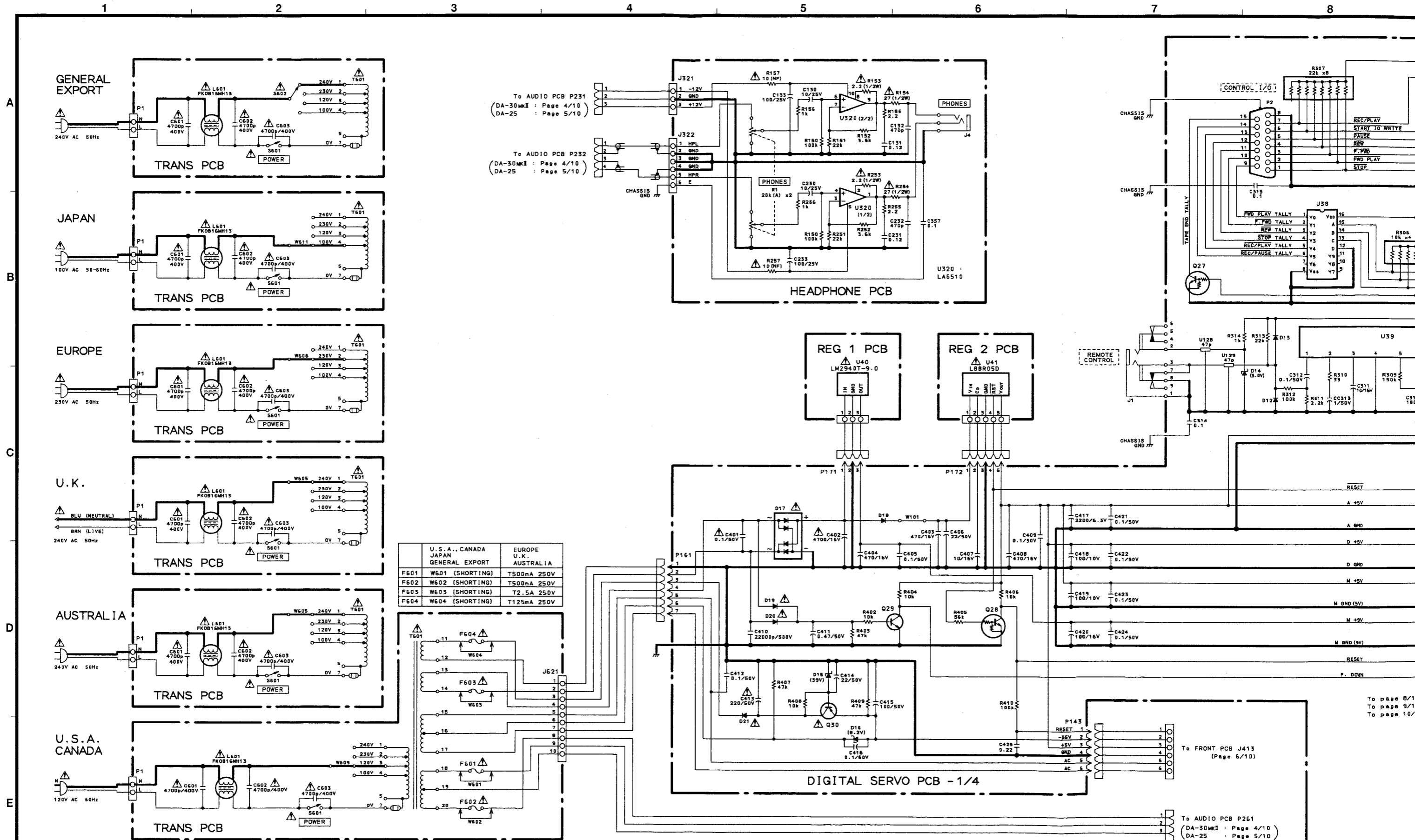

	U.S.A., CANADA JAPAN GENERAL EXPORT	EUROPE U.K. AUSTRALIA
F601	W601 (SHORTING)	T500mA 250V
F602	W602 (SHORTING)	T500mA 250V
F603	W603 (SHORTING)	T2.5A 250V
F604	W604 (SHORTING)	T1.25mA 250V

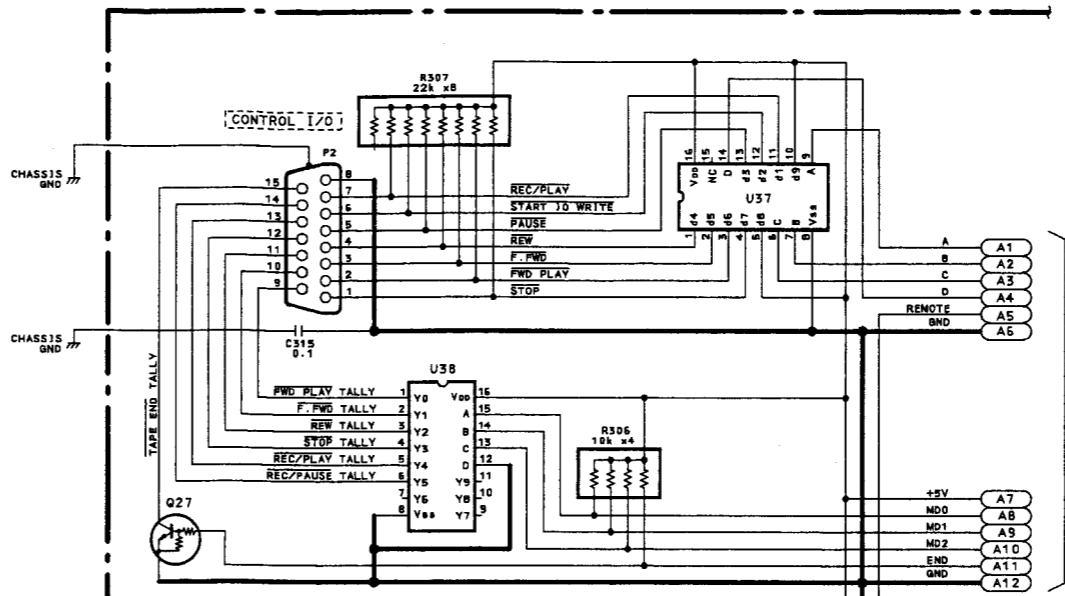
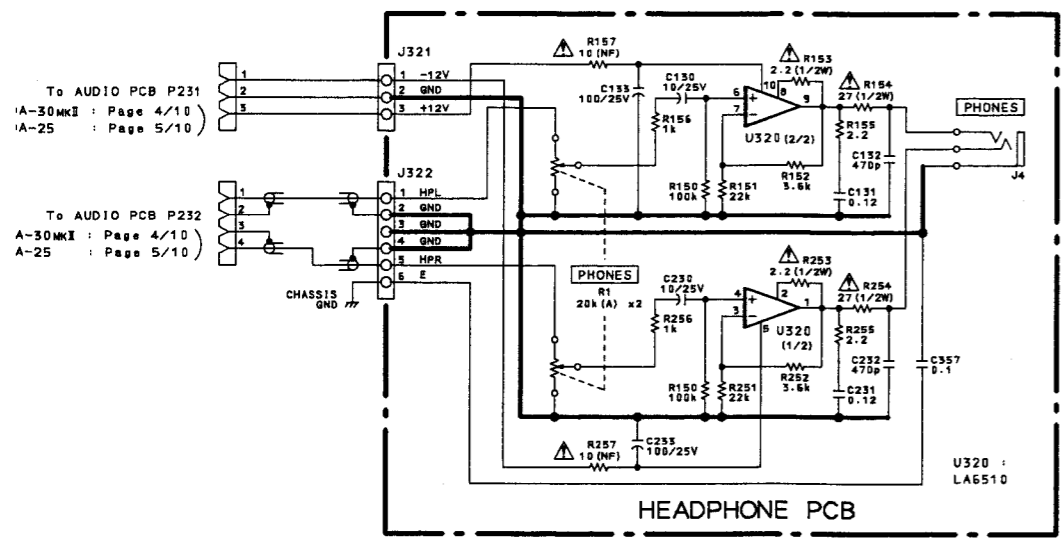

To page 9/10

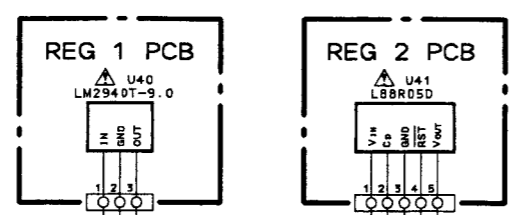

EUROPE	U.K.	AUSTRALIA
T500mA	250V	
T500mA	250V	
T2.5A	250V	
T1.25mA	250V	

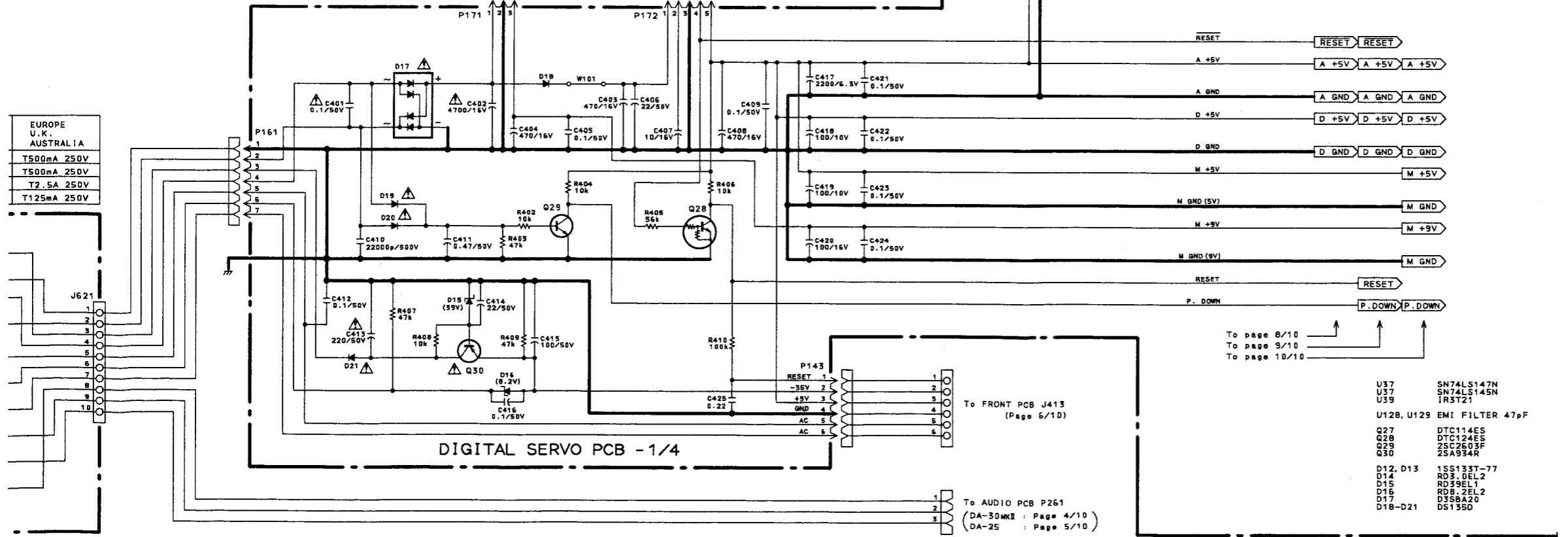

1 2 3 4 5 6 7 8

A  
B  
C  
D  
E

- B1 XTTEST
- B2 RP MODE
- B3 CDATA1
- B4 CCK
- B5 CSEL
- B6 EOT
- B7 BOT
- B8 SWH
- C1 PARITY
- C2 ATPEND
- C3 SWH
- C4 SREF
- C5 PBCK
- C6 EOT
- C7 BOT
- C8 FCH
- C9 CDATA1
- C10 CCK
- C11 CTRL
- C12 SFSYNC
- B9 SIG IN
- B10 COAX/AES
- B11 PDATA
- B12 FCH
- B13 TX GATE
- B14 RX PLUL
- B15 CLD
- B16 PBCK
- B17 VPL
- B18 MUTE
- B19 COATAQ
- B20 CTRL
- B21 LV DATA
- B22 LVCK
- B23 SFSYNC
- B24 FSYNC
- B25 VDD
- B26 MONS
- B27 QDATA
- B28 QBCK
- B29 LP
- B30 MPX
- A+5V A +5V
- A GND A GND
- RESET RESET
- D +5V D +5V
- D GND D GND

- U1 HD4922BAFS
- U2 HNS5258LF
- U3 YMS437C-F
- U4 TC74HC8BAF
- U5 TC74HC84AF
- U6 TC74HC84AF
- U7 TC74HC84AF
- U8 TC74HC84AF
- U9 TC74HC84AF
- U10 TC74HC84AF
- U11 MC3405SMEL
- U12 SN74ALS624NS
- U13 TC74HC125AF
- U14 TC74HC84AF
- U101-U106 EMI FILTER 1000pF
- U107-U110 EMI FILTER 10000pF
- U111-U115 EMI FILTER 10000pF
- U116-U126 EMI FILTER 1000pF
- U127 EMI FILTER 47pF
- Q1, Q2 2SC2412K
- Q3, Q4 2SC2520C
- Q5 DTC144ES
- D1-D4 MC932
- D5 1SS133T-77

To AUDIO PCB J214  
(DA-30MK2 : Page 4/10  
DA-25 : Page 5/10)

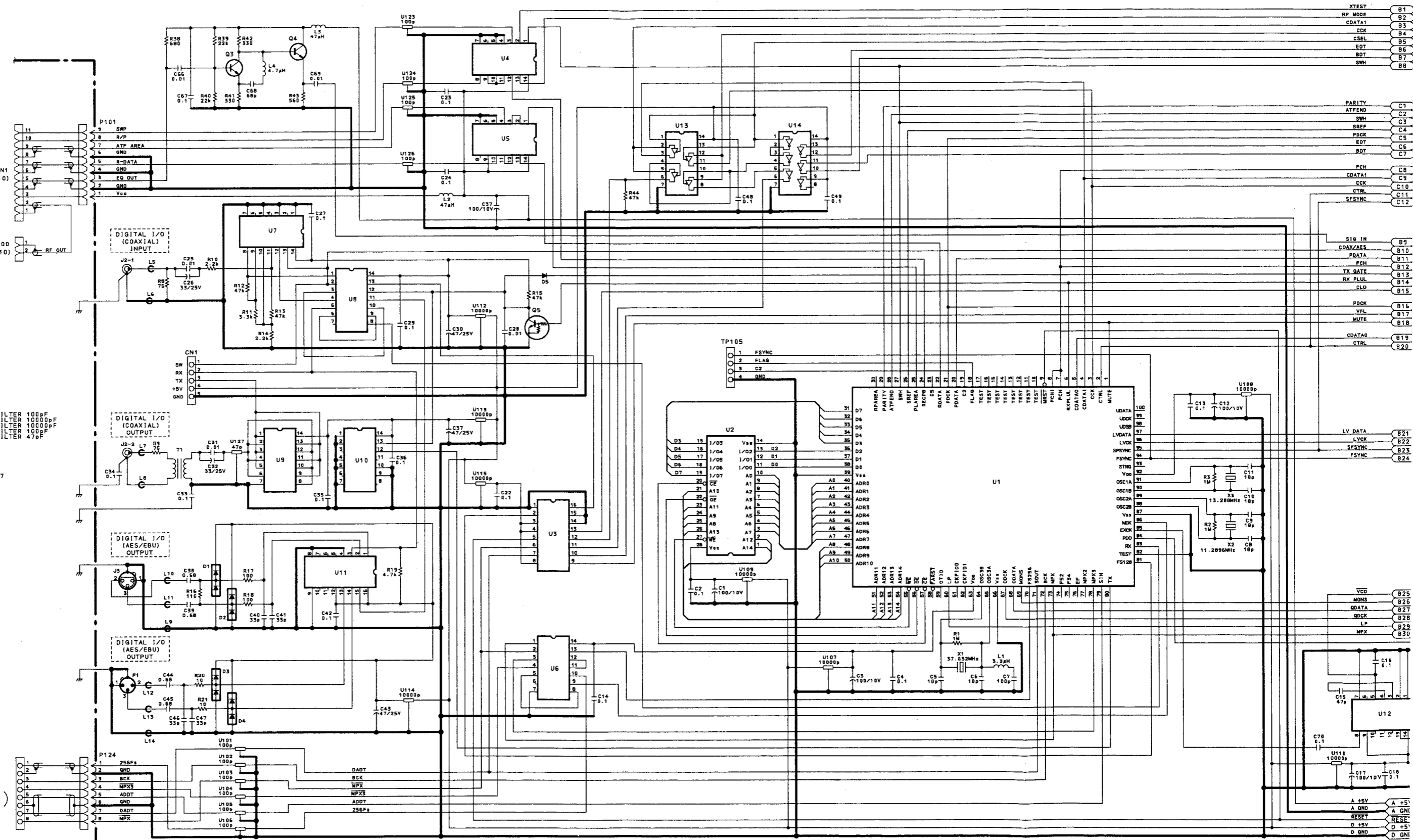

DIGITAL SERVO PCB -2/4

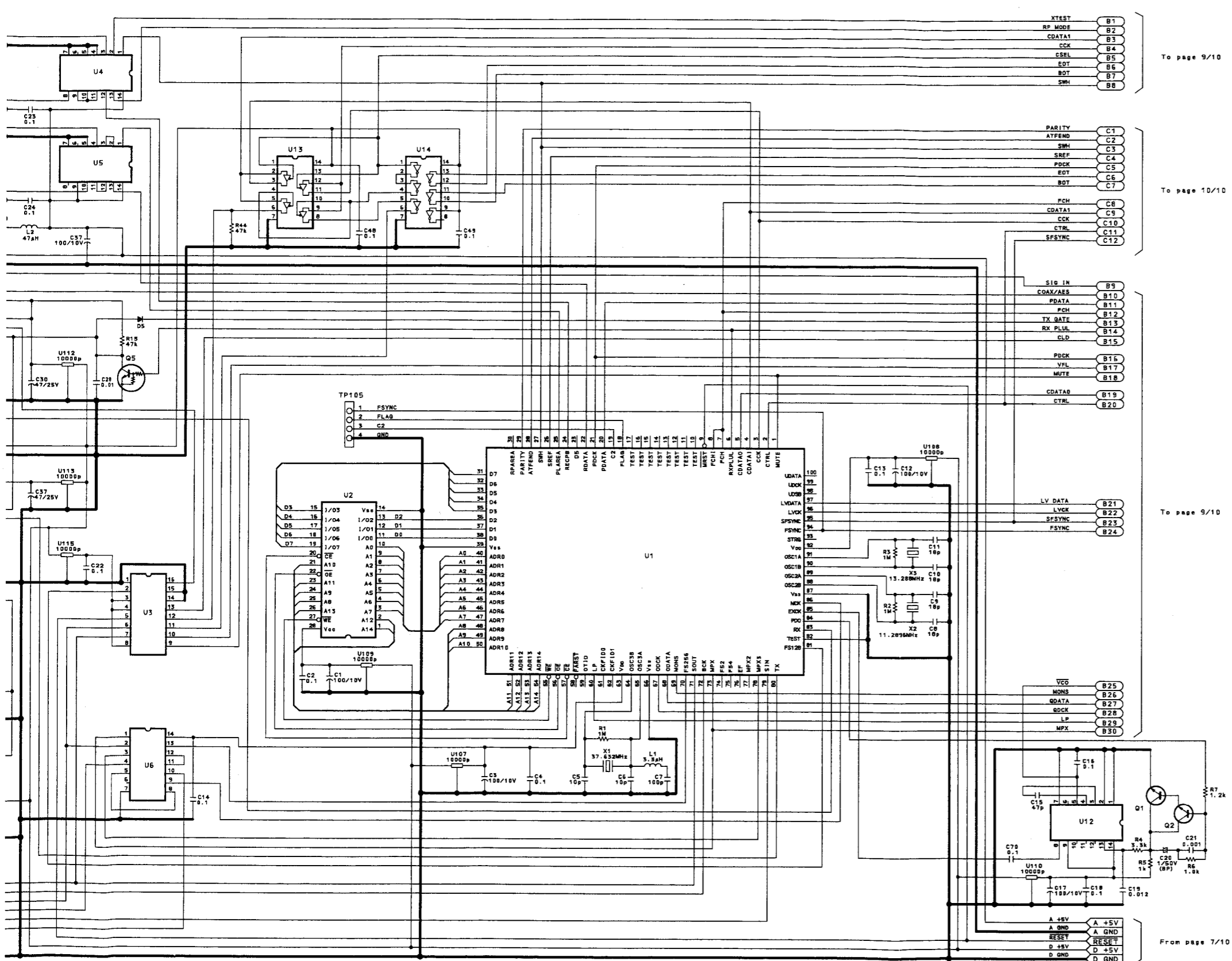

- XTAST B1
- RF MODE B2
- CDATA1 B3
- CCK B4
- CSEL B5
- EDT B6
- BDT B7
- SMH B8

To page 9/10

- PARITY C1
- ATFEND C2
- SMH C3
- SREF C4
- PDCK C5
- EDT C6
- BDT C7
- FCH C8
- CDATA1 C9
- CCK C10
- CTRL C11
- SFSYNC C12

To page 10/10

- SIG IN B9
- COAK/AES B10
- DATA B11
- FCH B12
- TX GATE B13
- RX PLUL B14
- CLD B15
- PDCK B16
- VFL B17
- MUTE B18
- CDATA0 B19
- CTRL B20

To page 9/10

- LV DATA B21
- LVCK B22
- SFSYNC B23
- FSYNC B24

- VEG B25
- MONS B26
- QDATA B27
- RDCK B28
- LP B29
- MPX B30

From page 7/10

- A +5V A +5V
- A GND A GND
- RESET RESET
- D +5V D +5V
- D GND D GND





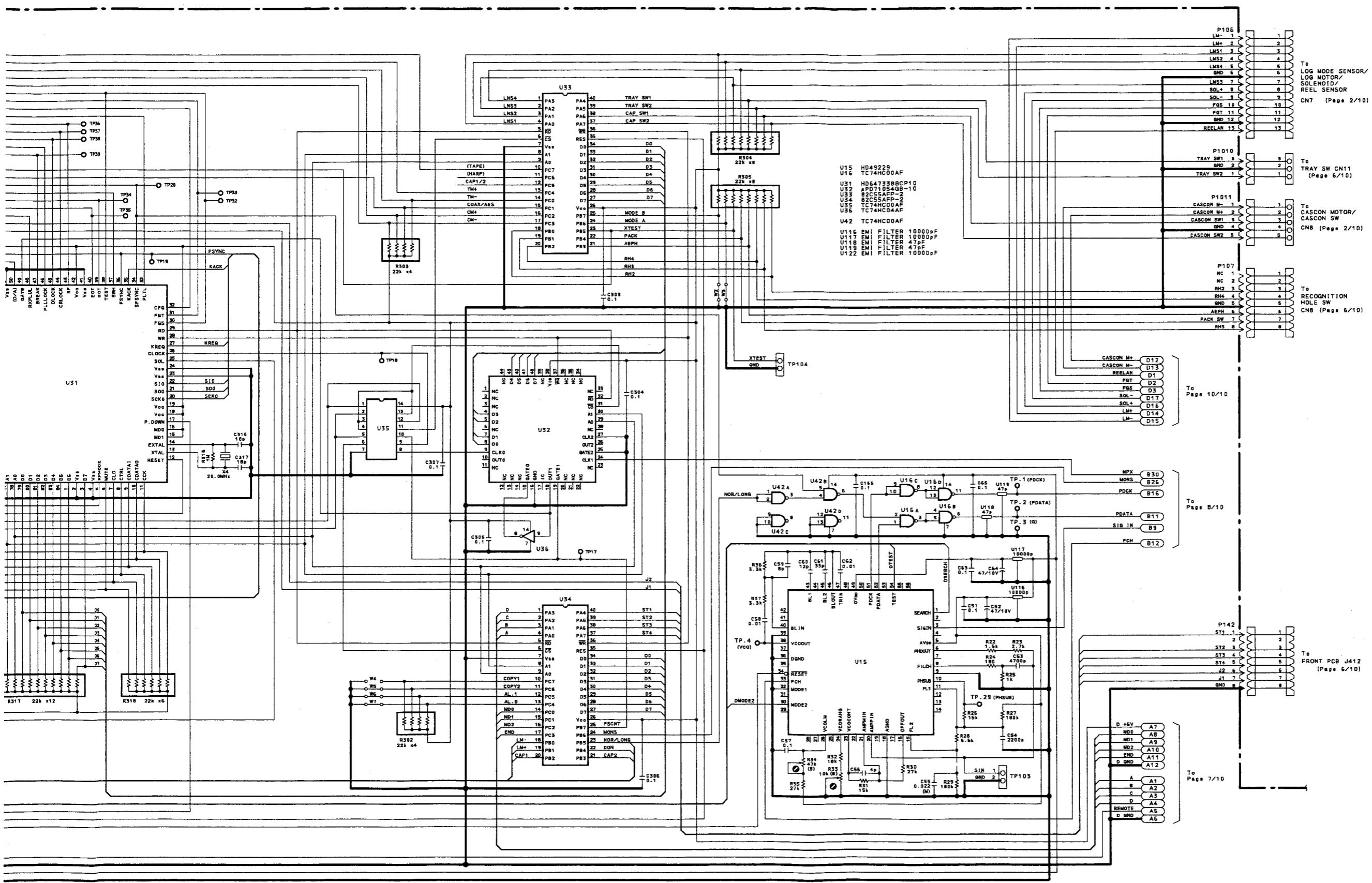

1 2 3 4 5 6 7 8

A  
B  
C  
D  
E

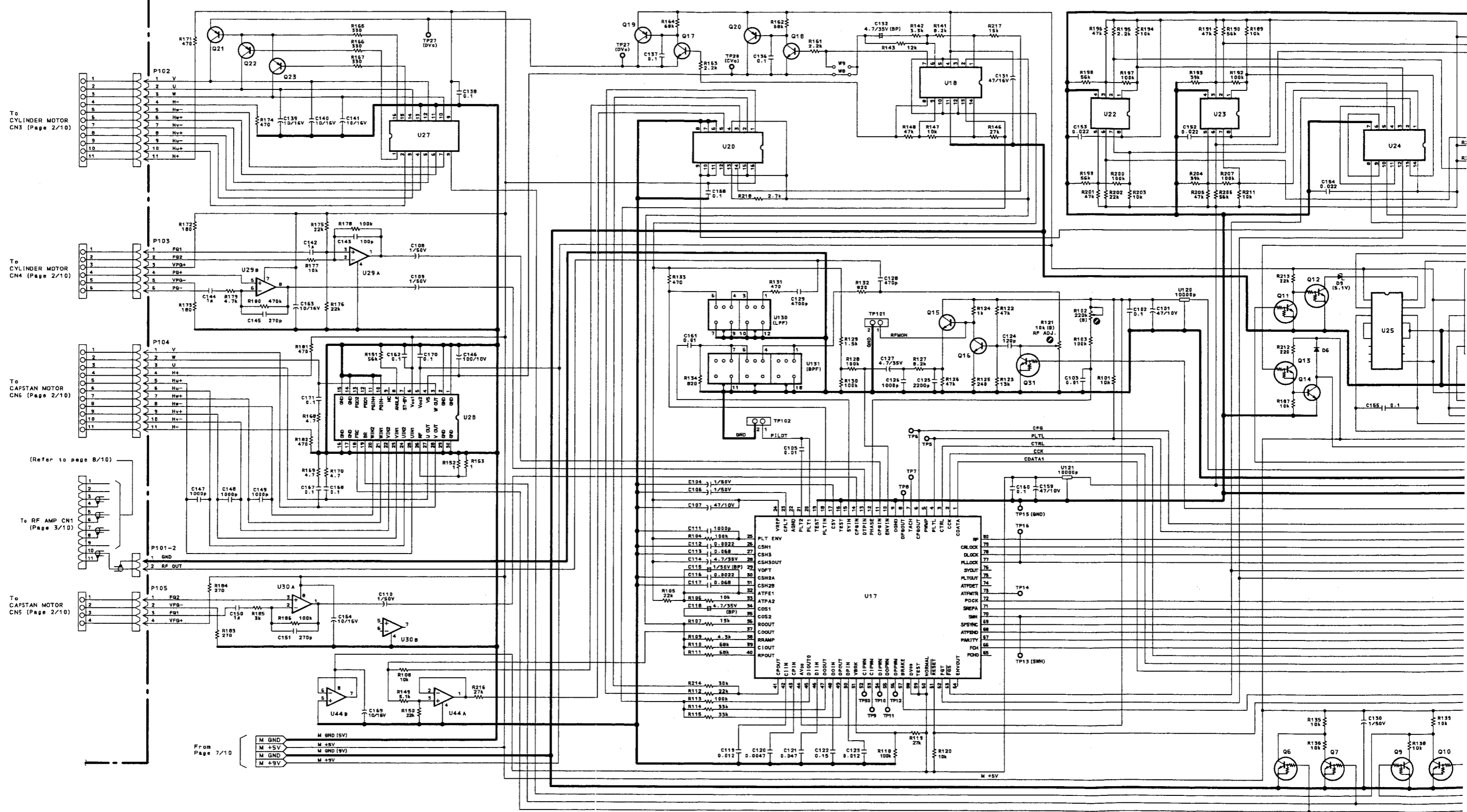

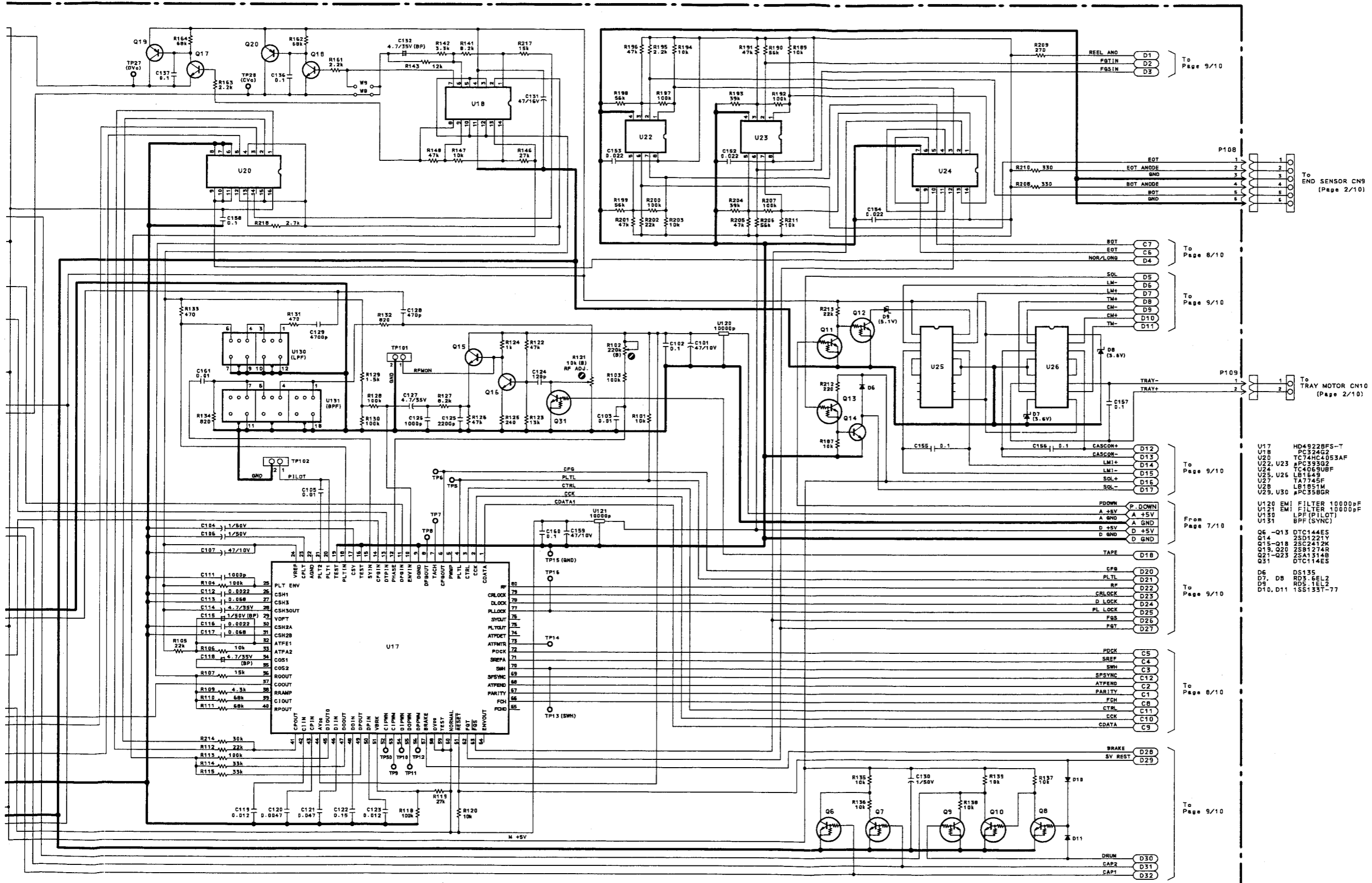

- U17 HD4922BF5-T
- U18 PC324G2
- U20 TC74HC4053AF
- U22, U23 #PC393G2
- U24 TC4069UBF
- U25, U26 LB1549
- U27 T47745F
- U28 LB1851M
- U29, U30 #PC358GR
- U120 EMI FILTER 10000pF
- U121 EMI FILTER 10000pF
- U130 LPF (PILOT)
- U131 BPF (SYNC)
- Q6-Q13 DTC144ES
- Q14 2SD1221V
- Q15-Q18 2SC2412K
- Q19, Q20 2SB1274R
- Q21-Q23 2SA1314B
- Q31 DTC144ES
- D6 DS135
- D7, D8 RD5 6EL2
- D9 RD5 1EL2
- D10, D11 1SS135T-77

DIGITAL SERVO PCB -4/4

# Digital Audio Tape Deck DA-30MK2/DA-25

## FRONT PCB ASSY

REF. NO.	PARTS NO.	DESCRIPTION
	*E95001700A	FRONT PCB ASSY[DA-30MK2]
	*E95001701A	FRONT PCB ASSY[DA-25]
	*E90001700A	FRONT PCB
	5332016900	SOCKET, IC 64P
	5730040200	SUPPORT, T-350
	5783603008	SCREW, BIND P-TITE M3X8
	5801519000	SPACER, LH-5 L=20.3
	M00000000A	BRACKET, VOL
D1, 2	5224012920	D, 1S2473 FT
D3, 4	5225018500	LED, SLR-34DU3F
D5	5225013600	LED, SLR-34MG3F (GRN)
D6	5225018500	LED, SLR-34DU3F
D7	5225013500	LED, SLR-34VR3F (RED)
D8, 9	5225018500	LED, SLR-34DU3F
D10, 11	5224012920	D, 1S2473 FT[DA-25]
D12	5224012920	D, 1S2473 FT
D13, 14	5224012920	D, 1S2473 FT[DA-25]
D15	5224012920	D, 1S2473 FT
D16-37	5224012920	D, 1S2473 FT[DA-25]
FL1	5347017300	FL TUBE, FIPI0AMW8
P412	5555590000	PLATE A, PCB GND
P425	5336249200	PLUG, CON. B02B-PH-K-S(WHT) [DA-30MK2]
P426	5336249600	PLUG, CON. B06B-PH-K-S(WHT)
P451	5336249800	PLUG, CON. B08B-PH-K-S(WHT)
Q1, 2	5230780900	TR, 2SC-2603 F
Q3-9	5232255620	TR, DTC114ES
R1, R2	R0000030	VR, 1S2UVR14 10KAX2
R21	5242119200	R. ARRAY, RMLS-4J223
R30	5242119200	R. ARRAY, RMLS-4J223
R31-33	5242117300	R, ARRAY, RML-S8J-104
S1	5300918000	SW, SLIDE SSSU04-2
S2	5300919200	SW, SLIDE 2-3[DA-30MK2]
S2	5300915300	SW, SLIDE 1-2[DA-25]
S3	5300915300	SW, SLIDE 1-2[DA-30MK2]
S4	5300915300	SW, SLIDE 1-2
S5	5302101800	SW, TACT SKHHPK
S6	5302101800	SW, TACT SKHHPK[DA-30MK2]
S7	5302101800	SW, TACT SKHHPK
S8	5300915300	SW, SLIDE 1-2 N ESD1511205
S9-28	5302101800	SW, TACT SKHHPK
U1	S00155400A	IC, HD4074729S
U2	5220066700	IC, HD74HC14P
X1	5347012000	OSC, CERAMIC CST4, 19MGW

## TRANS PCB ASSY

REF. NO.	PARTS NO.	DESCRIPTION
	*E95002000A	TRANS PCB ASSY[J]
	*E95002011A	TRANS PCB ASSY[US, C]
	*E95002030A	TRANS PCB ASSY[GE]
	*E95002040A	TRANS PCB ASSY[E]
	*E95002050A	TRANS PCB ASSY[UK, A]
	*E90002000A	TRANS PCB
	5730007500	COVER, CAPACITOR[E, UK, A]
	5332015800	FUSE HOLDER, PCB[E, UK, A]
C601-603	△ 5267703800	SPARK KILLER, 4700PF 400V
F601, 602	△ 5041138000	FUSE, MINI 500MA 250V[E, UK, A]
F603	△ 5142190000	FUSE, MINI 2.5A 250V[E, UK, A]
F604	△ 5142180000	FUSE, MINI 125MA 250V[E, UK, A]
L601	△ 5292806300	FILTER, NOISE FKOB16MH13
P1	5327007200	TERMINAL, LAPPING 2P
S601	△ 5300054700	SW, PUSH SDDL1 1-1
S602	△ 5332030000	VOLTAGE SELECTOR[GE]
T601	△ E0000470	TRANSFORMER

## REG 1 PCB ASSY

REF. NO.	PARTS NO.	DESCRIPTION
	*E95002300A	REG 1PCB ASSY
	*E90002300A	REG 1 PCB
U40	△ S0000180	IC, LM2940T-9.0

## REG 2 PCB ASSY

REF. NO.	PARTS NO.	DESCRIPTION
	*E95002400A	REG 2PCB ASSY
	*E90002400A	REG 2 PCB
U41	△ S0000190	IC, L88R05D