

TEAC



SERVICE MANUAL

P-70

CD Drive Unit



CONTENTS

1 SPECIFICATIONS	2
2 ADJUSTMENTS AND CHECKS	3
3 EXPLODED VIEWS AND PARTS LIST	4
4 PC BOARDS AND PARTS LIST	12
5 INCLUDED ACCESSORIES	23

NOTES

- PC boards shown are viewed from parts side.
- Parts marked with * require longer delivery time.
- The parts with no reference number or no parts number in the exploded views are not supplied.
- As regards the resistors and capacitors, refer to the circuit diagrams contained in this manual.
- \triangle Parts marked with this sign are safety critical components. They must be replaced with identical components - refer to the appropriate parts list and ensure exact replacement.
- Parts of [] mark can be used only with the version designated.
[US]:U. S. A. [C]:CANADA [E]:EUROPE

1 SPECIFICATIONS

Pickup

Drive methodlinear motor drive
Typeobjective lens drive, optical three beams
Lens drive methodtwo-dimensional parallel drive
Light source.....semiconductor laser
Wavelength.....780nm

Digital output formats

Base sampling frequency44.1kHz
Frequency precision±50PPM (indication: ±1.000PPM)
Quantization bits16 bits linear/channel
Transfer rate.....3.072Mb/sec.
A type modulation.....biphase, mark modulation

Base sampling frequency88.2kHz
Frequency precision±50PPM (indication: ±1.000PPM)
Quantization bits24 bits linear/channel
Transfer rate.....6.144Mb/sec.
A type modulation.....biphase, mark modulation

Base sampling frequency176.4kHz
Frequency precision±50PPM (indication: ±1.000PPM)
Quantization bits24 bits linear/channel
Transfer rate.....6.144Mb/sec. (double wire)
A type modulation.....biphase, mark modulation

Digital output terminals

RCA (COAXIAL)0.5Vp-p/75 ohm
XLR (BALANCED).....4.5Vp-p/110 ohm
OPTICAL(TOS) -12.5 ~ -16dBm

Word synchronization input format

BNC44.1kHz, 88.2kHz rectangular 4.5Vp-p/75 ohm

General

Power supplyAC 230V, 50Hz (Europe model)
AC 120V, 60Hz (U.S.A./Canada model)
AC 220V, 60Hz (Korea model)
Power consumption25W
Dimension (WxHxD).....465 x 162 x 355 (mm)
Weight.....about 25 kg

Remote control unit

Type.....infrared pulse system
BatteryDC3V (AA battery, SUM-3 x 2)
Dimensions (WxHxD)57 x 21 x 216 (mm)
Weight.....about 320g (including batteries)

Accessories included with the player

Remote control unit x 1, Batteries (AA, SUM-3) x 2,
Power cord x 1, felt sheet x 3,
Metal tool for releasing and securing the anti-vibration clamp x 1,
Warranty card x 1, Owner's Manual x 1

Improvements may result in specification or feature changes
without notice.

SAFETY INFORMATION

This product has been designed and manufactured according to FDA regulations "title 21, CFR, chapter 1, subchapter J, based on the Radiation Control for Health and Safety Act of 1968", and is classified as a class 1 laser product. There is no hazardous invisible laser radiation during operation because invisible laser radiation emitted inside of this product is completely confined in the protective housings. The label required in this regulation is shown ①.

● CAUTION

USE OF CONTROLS OR ADJUSTMENT OR PERFORMANCE OF PROCEDURES OTHER THAN THOSE SPECIFIED HEREIN MAY RESULT IN HAZARDOUS RADIATION EXPOSURE.

Optical pickup:

Type : KSS-151A
Manufacturer : SONY Corporation
Laser output : Less than 0.2 mW on the objective lens
Wavelength : 760 - 800 nm

① For U.S.A.

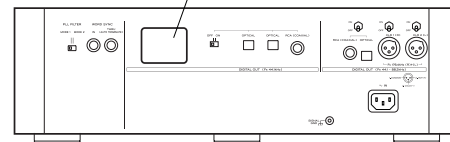
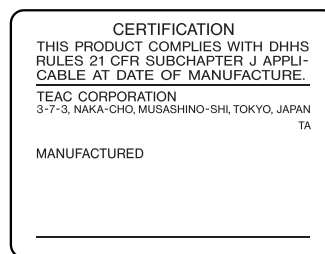

2 ADJUSTMENTS AND CHECKS

2-1 Replacement of the Pickup Assembly

2-1-1 Cautions in handling

- Before removing the pickup assembly be sure to solder-bridge where indicated in the inset to prevent the laser diode from being electrostatically damaged. After replacing the pickup assembly, be sure to unsolder the antistatic bridge. Or else the laser diode does not function.

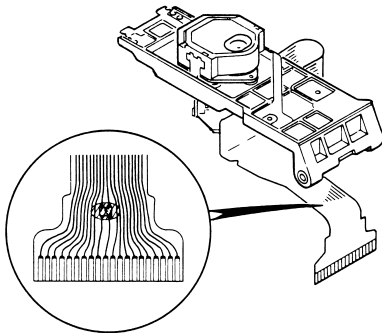

- Before servicing the pickup assembly be sure to prevent electrostatic-inducer destruction by grounding not only test equipment in use but also yourself.
- In case of mounting and dismantling the assembly, do not touch the actuator, photosensor and LD plate.
- Don't touch the plated portion of the flat cable end directly with fingers.
- Use care not to break the flat cable.
- Soldering must be done quickly at less than 30W, 320°C.
- Don't disassemble the pickup ass'y.
- Don't apply shock to the pickup ass'y.
- Don't place the assembly in a place subject to excessive dust, heat or moisture.

2-1-2 Objective

- Never look directly into the LD or observe the laser beam through another lens or mirror.
- Don't touch the objective with fingers.
- If objective becomes dirty, playback will deteriorate.
To clean the objective, moisten a good cleaning tissue, such as made by KODAK, in isopropyl alcohol and wipe the objective gently. Wipe off and excess fluid with a dry cleaning tissue.

2-2 Sled balance adjustment

1. Adjust V403 for 0V potential between P415 pin 1 (SO) and pin 2 (GND).

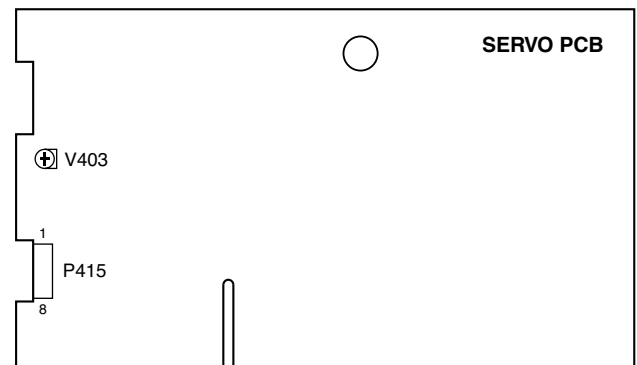

The pickup is secured with an anti-vibration clamp in order to reduce vibration during transport. This must be released before use.

Releasing the anti-vibration clamp

1. Place the unit on its side, left side down, as shown here.
2. Use the supplied tool and insert it into the hole on the bottom.
3. Turn the tool about 30 degrees counter-clockwise in the FREE direction.

Securing the anti-vibration clamp

1. Remove any disc from the unit, disconnect the power, and place the unit on its side, left side down, as shown here.
2. Use the supplied tool and insert it into the hole on the bottom.
3. Turn the tool about 30 degrees clockwise in the LOCK direction.

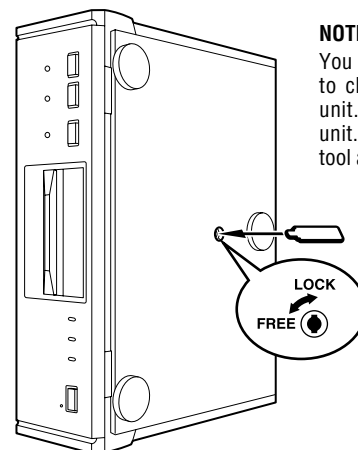

NOTE:

You do not need to use force to clamp and unclamp the unit. This may damage the unit. Use only the supplied tool and turn gently.

3 EXPLODED VIEWS AND PARTS LIST

EXPLODED VIEW-1

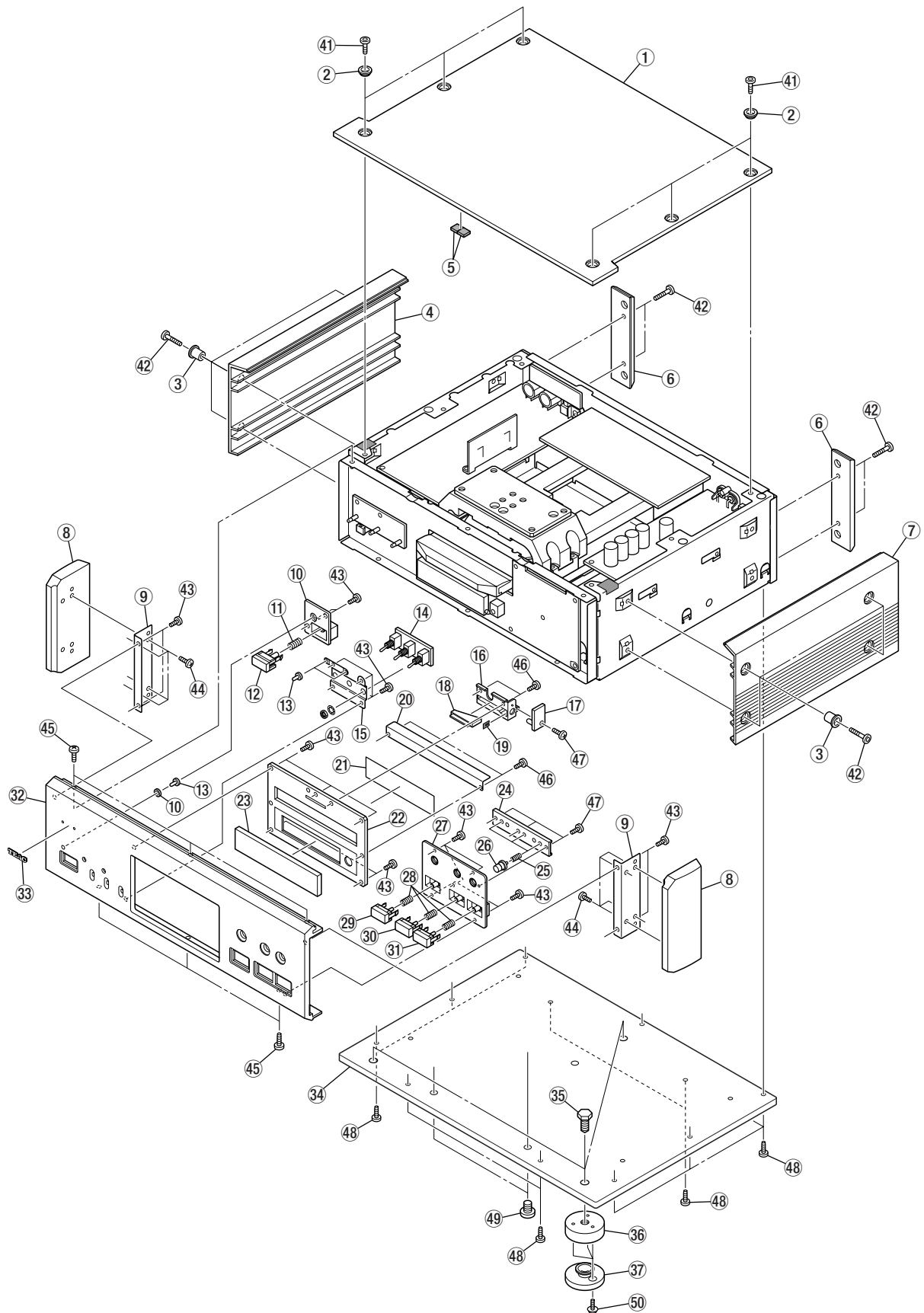

EXPLODED VIEW-1

REF. NO.	PARTS NO.	DESCRIPTION	REMARKS
1- 1	*M00941100A	TOP PANEL	
1- 2	M00260101A	COLLAR, SCREW(S)	
1- 3	M00260100A	COLLAR, SCREW(L)	
1- 4	*M00940501A	SIDE PANEL, L	
1- 5	*M00689100A	CUSHION, TRAY	
1- 6	*M00940800A	END CAP	
1- 7	*M00940601A	SIDE PANEL, R	
1- 8	*M00940700A	FRONT PANEL, CAP	
1- 9	*M00942900A	BRACKET, CAP L	
1-10	M00409500A	HOLDER, BUTTON (A)	
1-11	*5801070200	POWER SPRING	
1-12	M00941500A	BUTTON ASSY, POWER	
1-13	M00481000A	LENS	
1-14	E95135200A	PCB ASSY, FRONT TGL-SW	
1-15	*M01378000A	BRACKET, TOGGLE	
1-16	M01377900A	HOLDER, LENS	
1-17	E95135500A	PCB ASSY, TRY-LED	
1-18	M01377200A	LENS, LED	
1-19	*M01430700A	VINYL SHEET, BLIND	
1-20	*M01378300A	PLATE, COVER	
1-21	*M01254700A	FILTER	
1-22	*M01377300A	PANEL, SUB	
1-23	*M01396200A	COVER, FL	
1-24	*M00392000A	HOLDER, BUTTON	
1-25	*M00404600A	CPRSN SPRING, KNOB	
1-26	M00393102A	BUTTON ASSY, D=8 BR	
1-27	M00390300C	ESCUTCHEON, A	
1-28	*5801070100	KNOB SPRING	
1-29	M00614502A	BUTTON ASSY, STOP BR	
1-30	M00614302A	BUTTON ASSY, PLAY BR	
1-31	M00614402A	BUTTON ASSY, PAUSE BR	
1-32	*M01377100A	FRONT PANEL	
1-33	*5801533720	NAMEPLATE, TEAC (BLK. BLK)	
1-34	*M01517900A	CHASSIS, BASE	
1-35	M01494801A	FOOT (A), HEX 21	
1-36	M01494900A	FOOT (B)	
1-37	M01495000A	STAND, FOOT	
1-41	*5801539500	SCREW, HEXAGON 3X8 BLACK	
1-42	B00023000A	SCREW, HEXAGON 3X17.5 BLACK	
1-43	*5780023006	SCREW, BPA 3X6 NB	
1-44	*5783033006	SCREW, S-TITE BIND M3X6	
1-45	*B00090900A	SCREW, VPB M3X8FNB	
1-46	*5780023008	SCREW, BPA 3X8 NB	
1-47	*5783603008	SCREW, P-TITE BIND M3X8	
1-48	*B00091000A	SCREW, VPB M3X10FNB	
1-49	*B0009130	SCREW, BPA M8X10FNI	
1-50	*5783113006	SCREW, ZPAT 3X6 NB	

EXPLODED VIEW-2

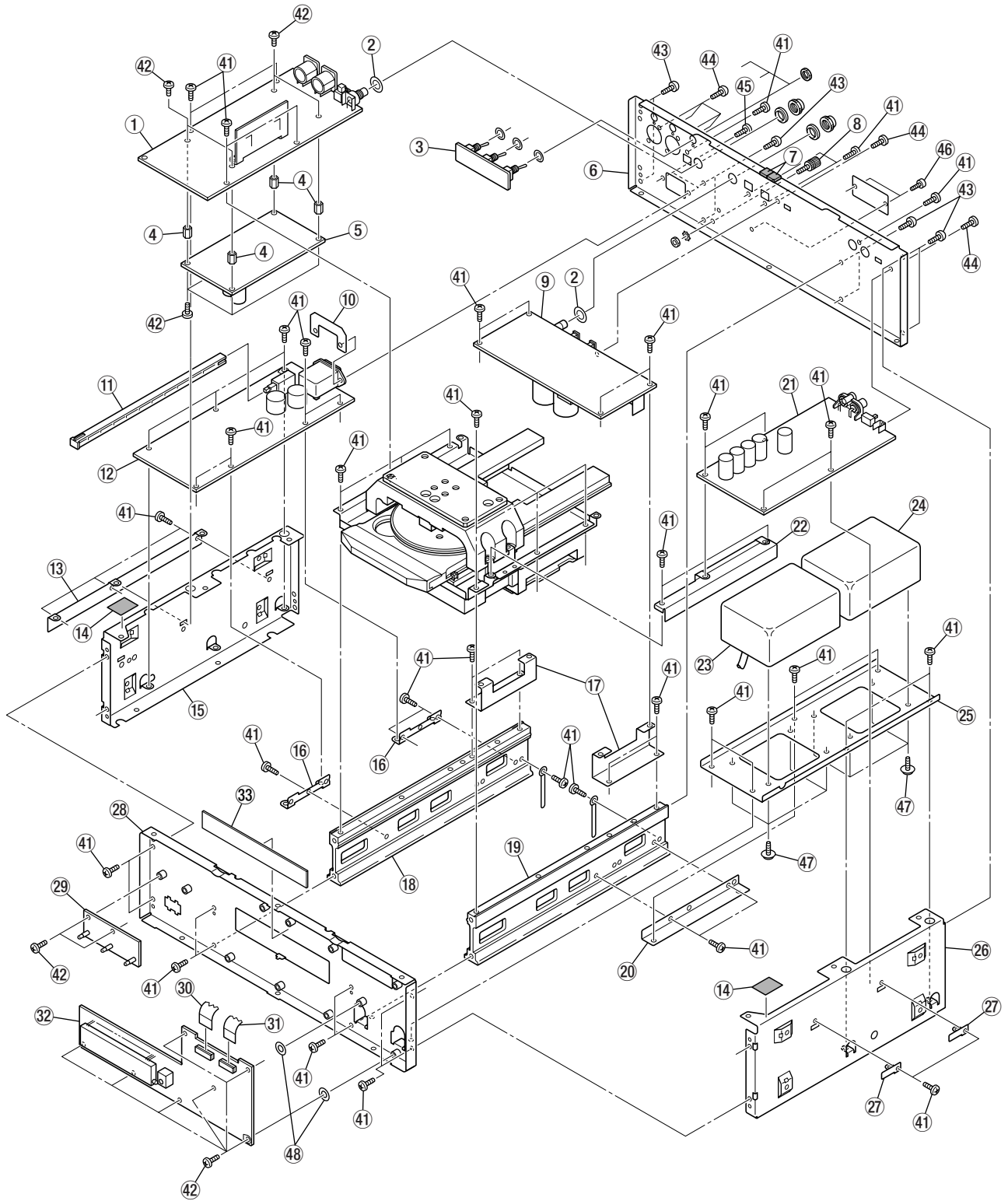

EXPLODED VIEW-2

REF. NO.	PARTS NO.	DESCRIPTION	REMARKS
2- 1	E95135000A	PCB ASSY, UP-CON	
2- 2	*M01259600A	WASHER, POLY 10.5X20X0.2T	
2- 3	E95135300A	PCB ASSY, REAR TGL-SW	
2- 4	*M01381000A	SPACER, PCB L9	
2- 5	E95134900A	PCB ASSY, CLOCK	
2- 6	*M01377500A	REAR PANEL	
2- 7	*M00689100A	CUSHION, TRAY	
2- 8	*5332031900	EARTH TERMINAL, M3	
2- 9	E95134800A	PCB ASSY, PWR [US, C]	
	E95134850A	PCB ASSY, PWR [E]	
2-10	*M00943200A	PLATE, EMI FILTER	
2-11	M00388800A	ROD, POWER SW	
2-12	E95134700A	PCB ASSY, AC-IN	
2-13	*M00942600A	BRACKET, PCB POWER	
2-14	*M00289000A	SHIELD SHEET	
2-15	*M00942400A	CHASSIS, SIDE L	
2-16	*M00388000B	BRACKET, PWR SW PCB	
2-17	*M00942800A	BRACKET, PCB D/O	
2-18	*M00942200A	FRAME, CHASSIS L	
2-19	*M00944100B	FRAME, CHASSIS R	
2-20	*M00942700A	BRACKET, TRANS	
2-21	E95135100A	PCB ASSY, WORD-IN	
2-22	*M00387901A	BRACKET, AUDIO PCB NI	
2-23	△ E00561920A	POWER TRANSFORMER, RCOA A [US, C]	
	△ E00561950A	POWER TRANSFORMER, CUTCOA A [E]	
2-24	△ E00561820A	POWER TRANSFORMER, RCOA D [US, C]	
	△ E00561850A	POWER TRANSFORMER, CUTCOA D [E]	
2-25	*M00943300A	BASE, TRANS	
2-26	*M01377800A	CHASSIS, SIDE R	
2-27	*M01377400A	BRACKET, PCB WORD IN	
2-28	*M01377600A	CHASSIS, FRONT	
2-29	E95135400A	PCB ASSY, LED	
2-30	E00183800A	FLAT CABLE, SERVO B	
2-31	E00183700A	FLAT CABLE, SERVO A	
2-32	E95134600A	PCB ASSY, FL KEY	
2-33	M01499700A	PLATE, LIMIT DISC	
2-41	*5783533008	SCREW, BPB 3X8 NB	
2-42	*5780023006	SCREW, BPA 3X6 NB	
2-43	*B00090900A	SCREW, VPB M3X8FNB	
2-44	*5783613008	SCREW, VPCR 3X8 NB	
2-45	*5730036400	SCREW, CLAW BIND M3X8 (BLK)	
2-46	*5781702606	SCREW, HEXAGON M2, 6X6 (N1)	
2-47	*B00100800A	SCREW, PPSB 4X10FZC	
2-48	*M00319700A	WASHER, ADHESIVE 5X12X0.1T	

EXPLODED VIEW-3

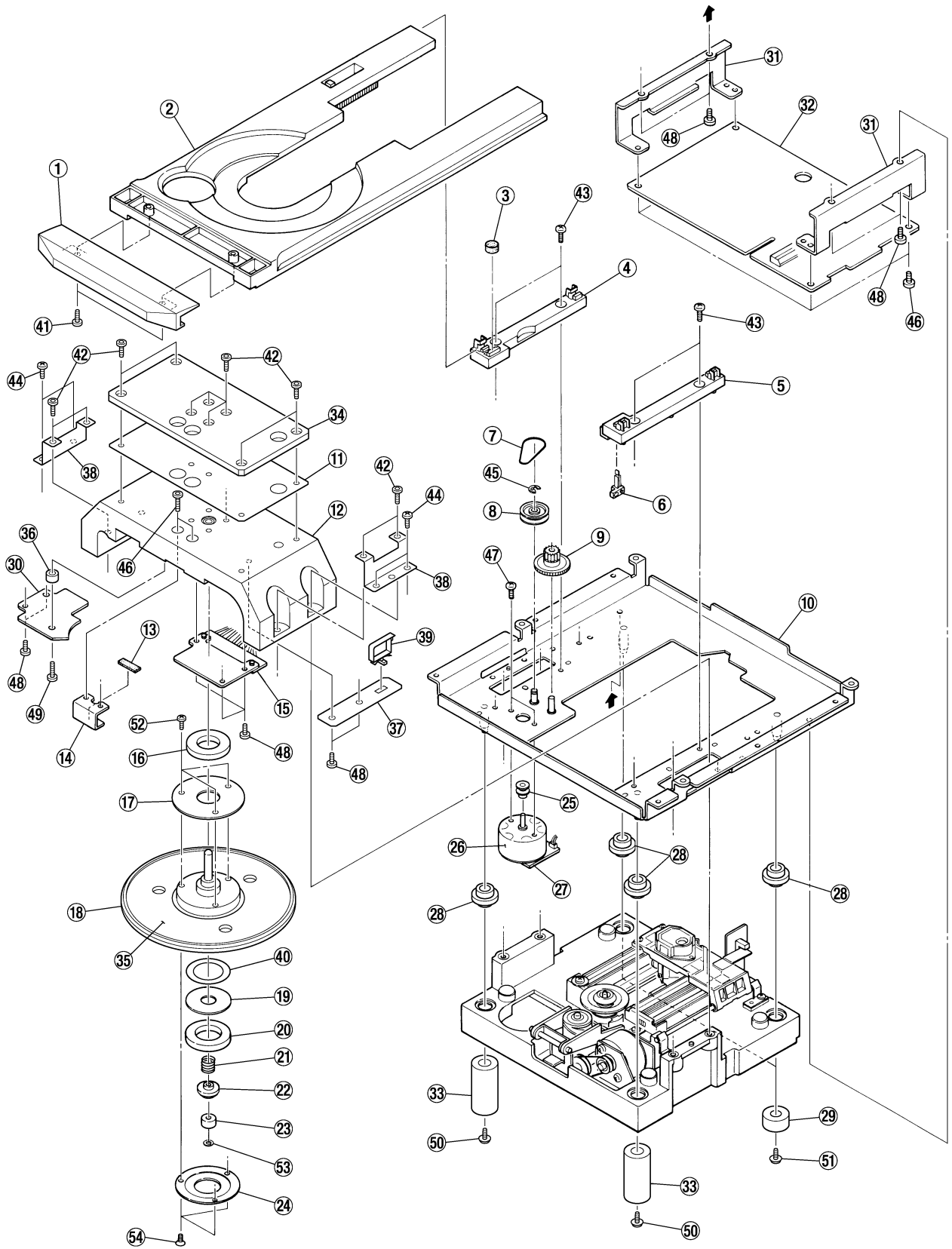

EXPLODED VIEW-3

REF. NO.	PARTS NO.	DESCRIPTION	REMARKS
3- 1	M00941030A	PANEL, TRAY SILVER	
3- 2	5801497202	TRAY (B)	
3- 3	* 5801132601	CUSHION	
3- 4	5801203100	GUIDE (L)	
3- 5	5801203002	GUIDE (R)	
3- 6	5301754000	SW, LEAF LSC-1220-1AU	
3- 7	5800979500	LOADING BELT	
3- 8	5800979400	GEAR (B)	
3- 9	M00350500A	GEAR (A)	
3-10	5801564804	MECH BASE CHASSIS (CU) ASSY	
3-11	* M01390200A	SHEET, SPINDLE SUPPORT	
3-12	M01390700A	HOUSING ASSY	
3-13	* 5801096900	RUBBER SHEET	
3-14	* 5801513200	ROTOR STOPPER	
3-15	* M00435200A	COIL ASSY	
3-16	M01445600A	MAGNET, ND 30X16X5	
3-17	M00399000A	YOKE, ROTOR	
3-18	M01081100B	TURNTABLE ASSY	
3-19	5801057000	CLAMPER YOKE	
3-20	5801493501	MAGNET, FB3G DH32X18X4.5FMS	
3-21	5801096300	PRESSURE SPRING (C)	
3-22	M01081200A	CAP, CENTER	
3-23	5801056900	CENTER RING	
3-24	5801057200	MAGNET HOLDER	
3-25	5800979201	MOTOR PULLEY	
3-26	5370009200	DC MOTOR, RF-500TB	
3-27	E95027100A	PCB ASSY, T-MOTOR	
3-28	* M00845900A	SPACER, A	
3-29	* M00846000A	SPACER, B	
3-30	E00586200A	PCB ASSY, DIRECTION	
3-31	* M00388300B	BRACKET, SERVO PCB	
3-32	E95063120A	PCB ASSY, SERVO	
3-33	* M01252300A	BASE, MECHA	
3-34	* M01390100A	PLATE, SPINDLE SUPPORT	
3-35	M01485600A	PLATE, TURNTABLE T1.2	
3-36	* M01390000A	SPACER, PCB DR	
3-37	* M01390400A	PLATE, CABLE	
3-38	* M01390500A	STOPPER, HOUSING	
3-39	M0150390	CABLE CLAMP, RLWS-1T	
3-40	M01481000A	CUSHION, CLAMP MAGNET	
3-41	* 5783543008	SCREW, P-TITE BIND M3X8 NB	
3-42	* 16460306	SCREW, CAP 3X6	
3-43	* 5783033008	SCREW, S-TITE BIND M3X8	
3-44	* 5783033008	SCREW, S-TITE BIND M3X8	
3-45	* 5786003000	RTNG RING-E, 3 JIS	
3-46	* 16460310	SCREW, CAP 3X10	
3-47	* 5780002603	SCREW, BPA 2.6X3 NB	
3-48	* 5780023006	SCREW, BPA 3X6 NB	
3-49	* 5780023012	SCREW, BPA 3X12 NB	
3-50	* 5780023008	SCREW, BPA 3X8 NB	
3-51	* 5783073008	SCREW, S-TITE PAN CUP M3X8	
3-52	* 5782512003	SCREW, PAN M2X3	
3-53	* 5785342200	WASHER, POLY 2.6X5X0.25T CUT	
3-54	* 5780212004	SCREW, FPA 2X4 NI	

EXPLODED VIEW-4

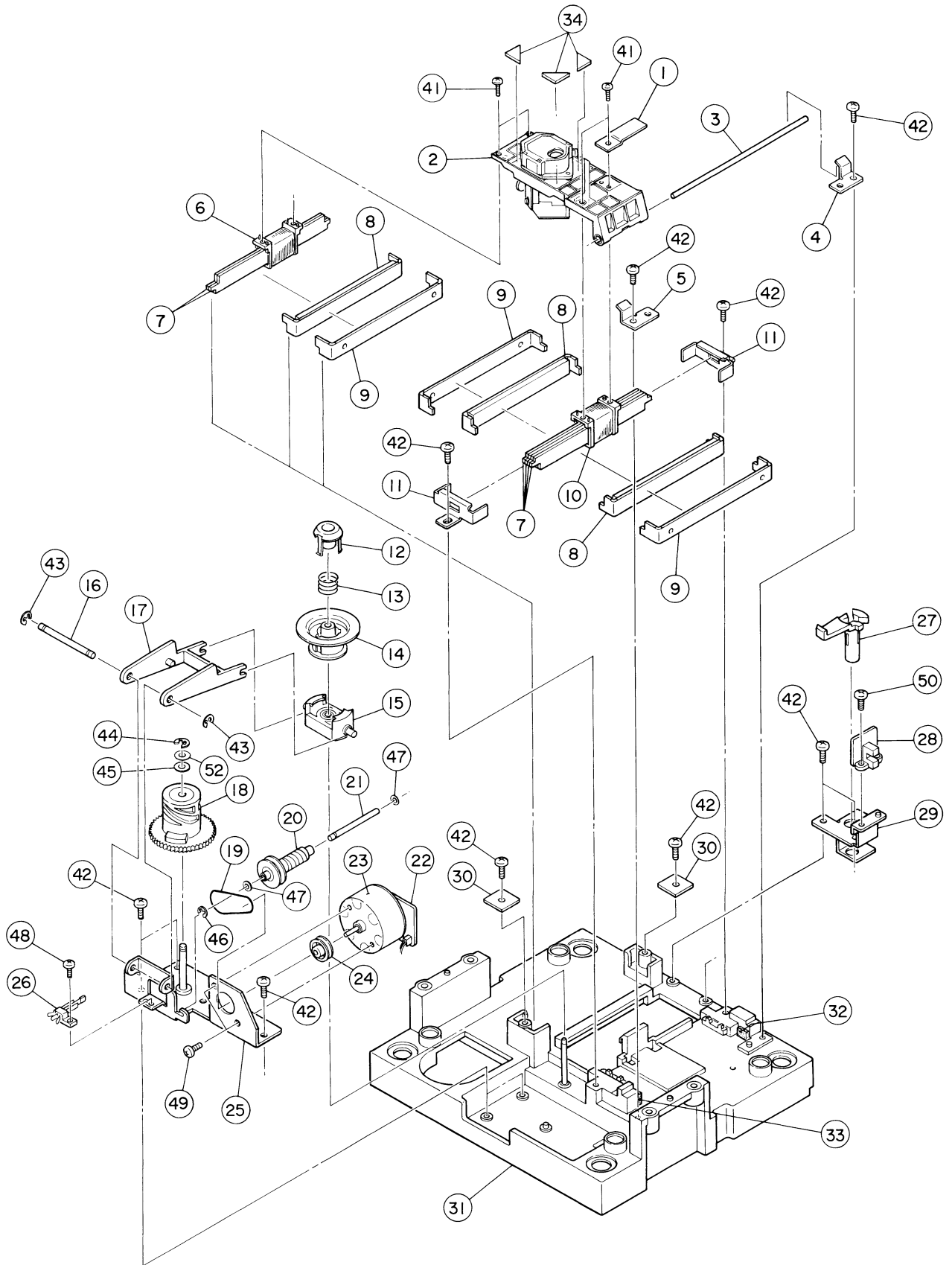

EXPLODED VIEW-4

REF. NO.	PARTS NO.	DESCRIPTION	REMARKS
4- 1	* 5801164700	SHUTTER	
4- 2	5347009800	LASER PICK UP	
4- 3	5801058900	GUIDE SHAFT	
4- 4	* 5801059100	SHAFT HOLDER(R)	
4- 5	* 5801059000	SHAFT HOLDER(F)	
4- 6	5801078300	COIL(S)	
4- 7	5801059402	YOKE(C)	
4- 8	* 5801097400	YOKE(B) ASSY	
4- 9	5801059200	YOKE(A)	
4-10	5801078200	COIL(D)	
4-11	5801059600	YOKE HOLDER	
4-12	* 5801167800	GUIDE RING	
4-13	* 5801096200	PRESSURE SPRING(G)	
4-14	5801165700	CLAMPER	
4-15	5801201100	HOLDER	
4-16	5801201800	SHAFT(B)	
4-17	5801201500	LIFT ARM	
4-18	5801202700	CYLINDER CAM	
4-19	5800979500	LOADING BELT	
4-20	5800669800	WORM ASSY	
4-21	* 5801201700	SHAFT(A)	
4-22	* E95027200A	PCB ASSY, C-MOTOR	
4-23	5370009200	DC MOTOR, RF-500TB	
4-24	5801170200	MOTOR PULLEY	
4-25	* 5801521501	CLAMPER BASE(B)	
4-26	5301754000	SW, LEAF LSC-1220-1AU	
4-27	* 5801164901	PU LOCK ARM	
4-28	* E95027300A	PCB ASSY, SENSOR	
4-29	* 5801164800	LOCK ARM BRACKET	
4-30	* M00097300A	PLATE, STOPPER A	
4-31	* 5801203506	MECH BASE	
4-32	* 5801288300	STOPPER(B)	
4-33	* M00460300A	STOPPER, PU	
4-34	* M00276500A	WEIGHT, PU	
4-41	* 5783011704	SCREW, B-TITE PAN M1.7X4	
4-42	* 5783533008	SCREW, BPB 3X8 NB	
4-43	* 5786002000	RTNG RING-E, 2 JIS	
4-44	* 5786003000	RTNG RING-E, 3 JIS	
4-45	* 5785314100	WASHER, POLY 4X8X0.5T	
4-46	* 5786001500	RTNG RING-E, 1.5 JIS	
4-47	* 5785302400	WASHER, POLY 2.1X5X0.25T	
4-48	* 5780132004	SCREW, PPAA 2X4 ZC	
4-49	* 5780002603	SCREW, BPA 2.6X3 NB	
4-50	* 5783033008	SCREW, S-TITE BIND M3X8	
4-52	* 5785304200	WASHER, POLY 4X8X0.25T	

4 PC BOARDS AND PARTS LIST

SERVO PCB

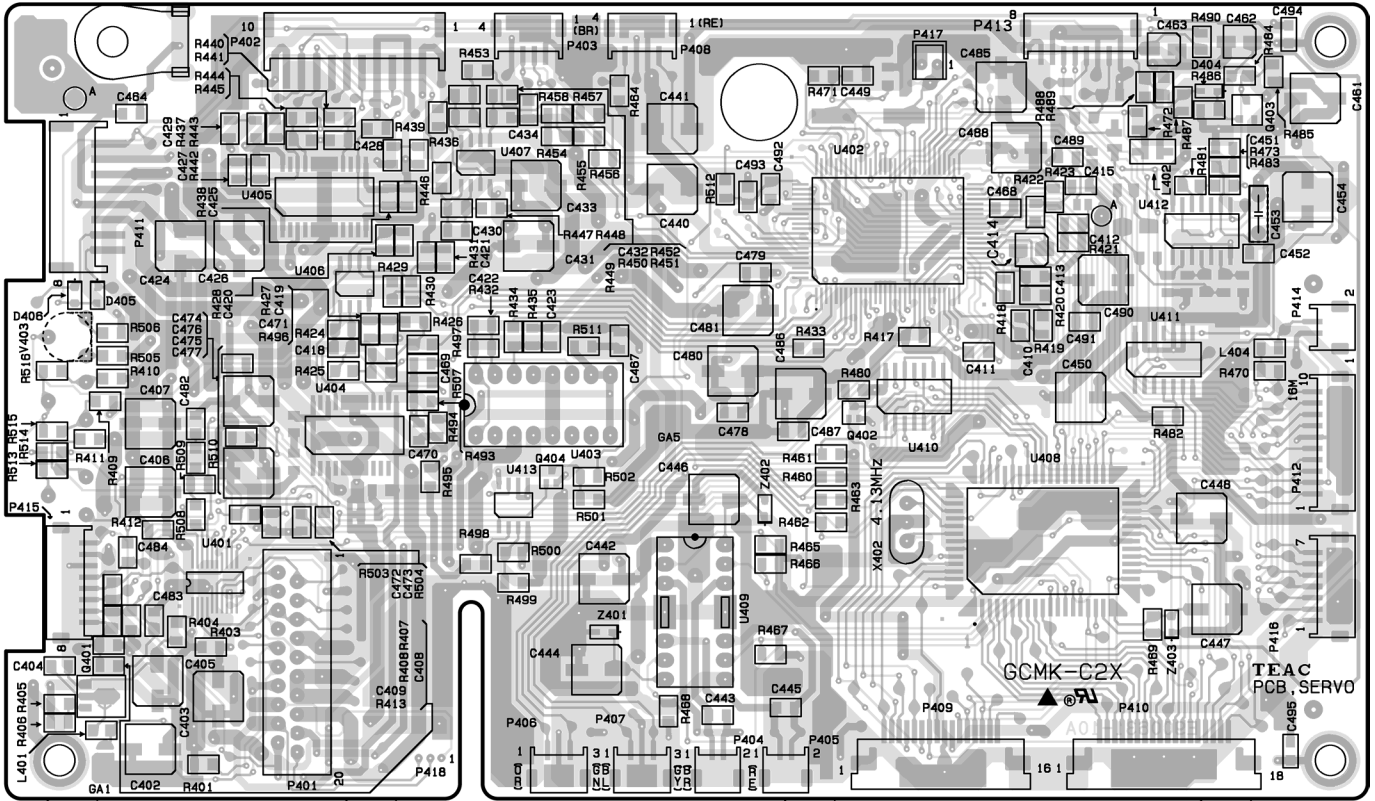

DIRECTION PCB

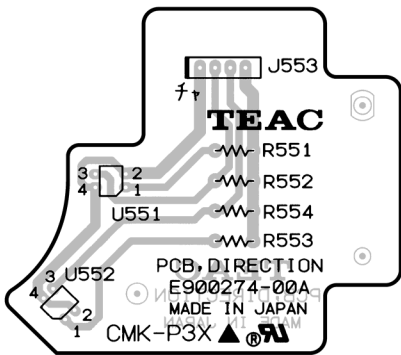

C-MOTOR PCB

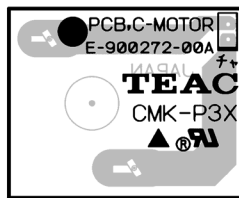

T-MOTOR PCB

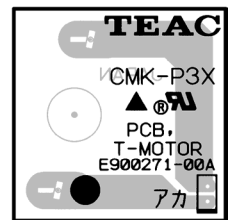

SENSOR PCB

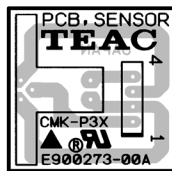

AC IN PCB

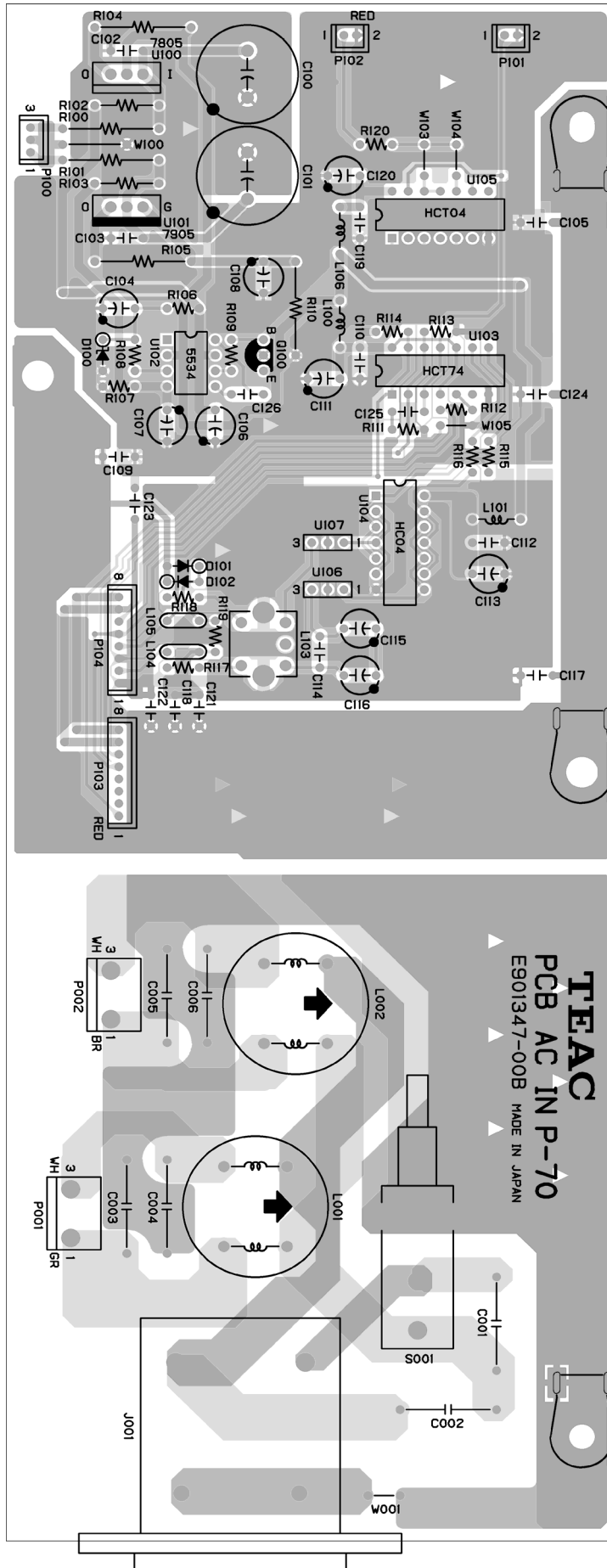

WORD IN PCB

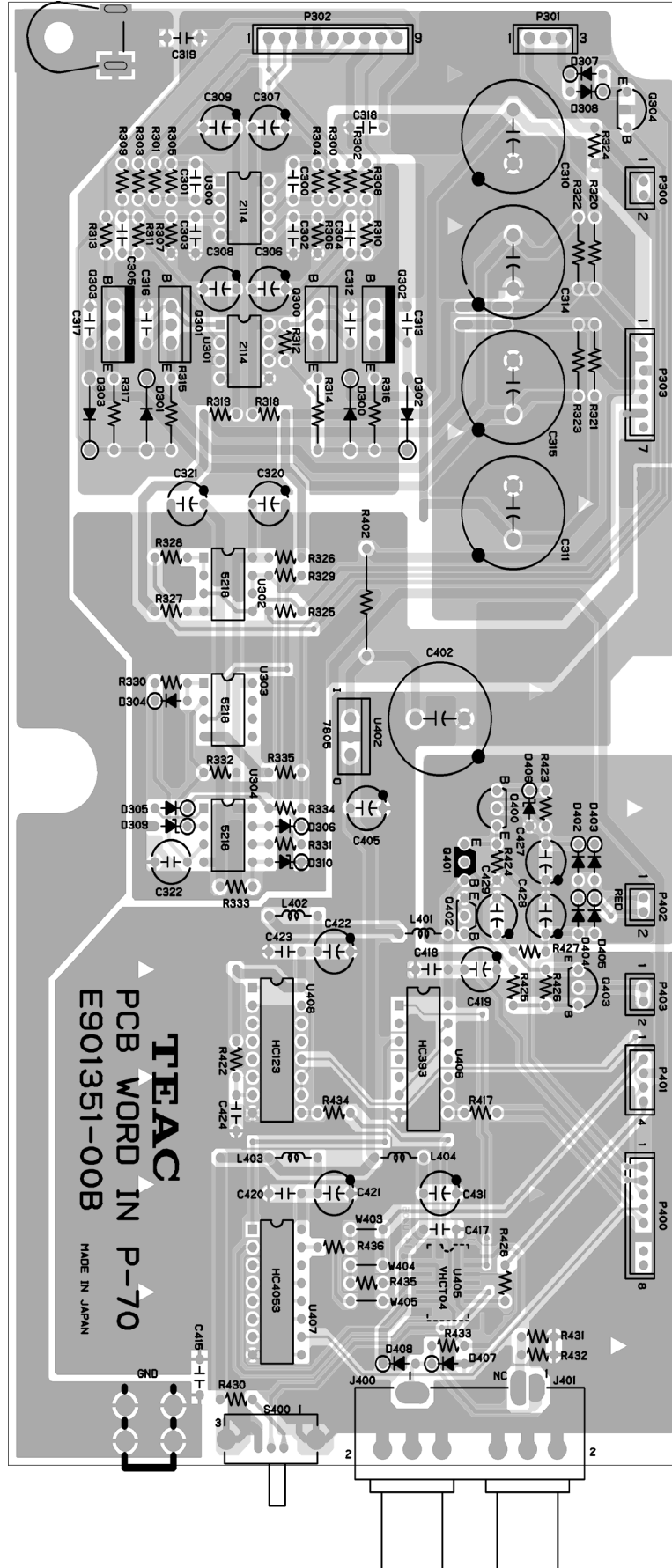

REAR TGL-SW PCB

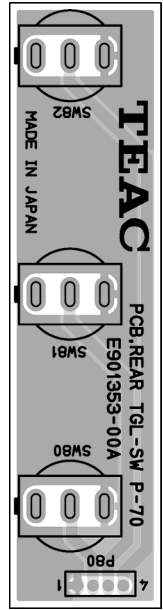

FRONT TGL-SW PCB

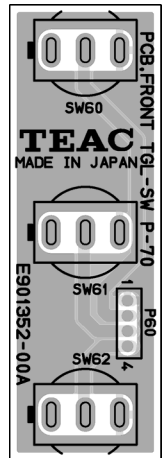

TRY-LED PCB

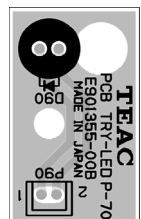

LED PCB

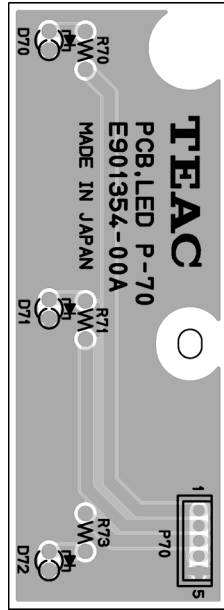

FL KEY PCB

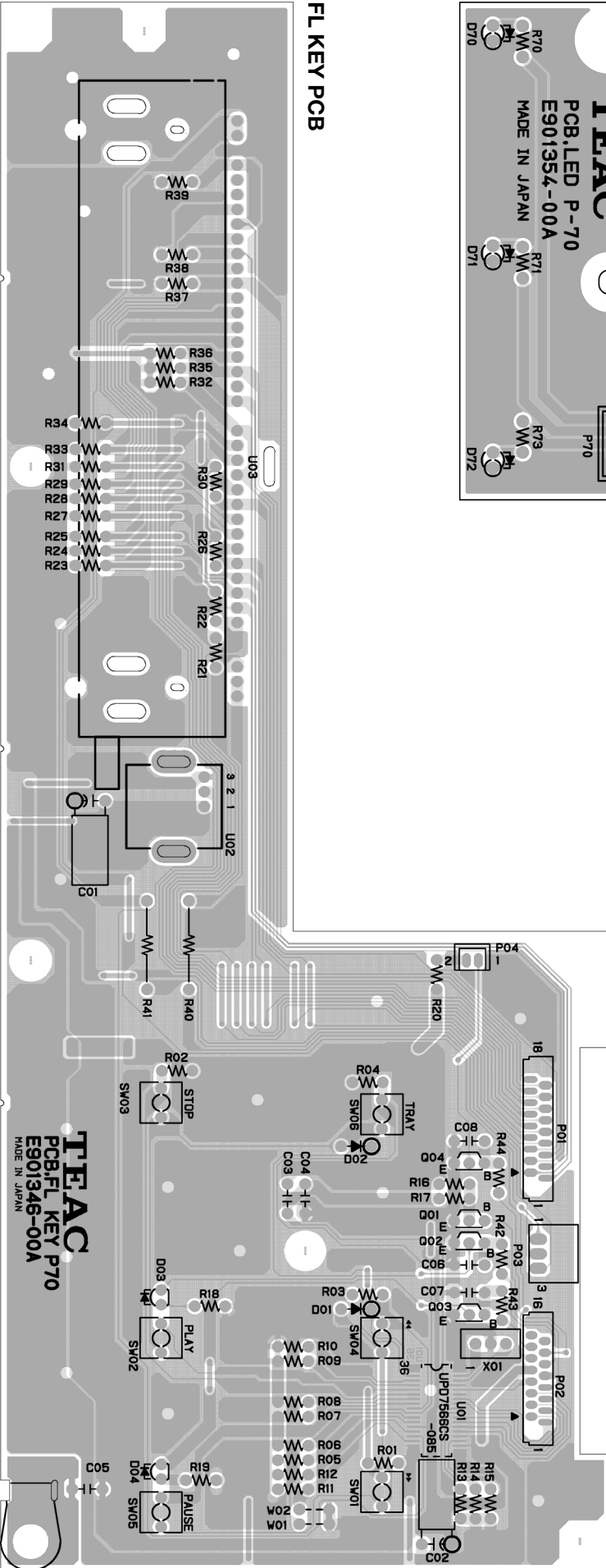

UP-CON PCB

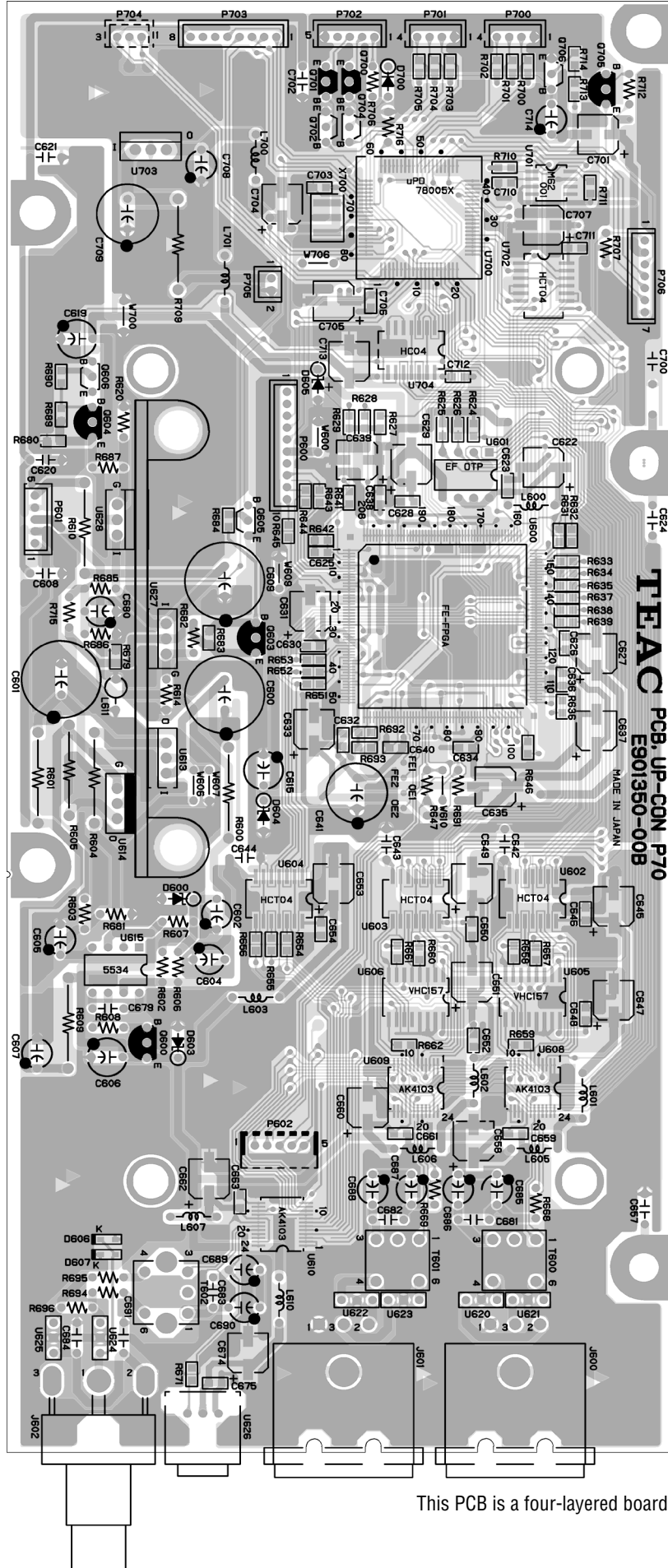

This PCB is a four-layered board.

CLOCK PCB

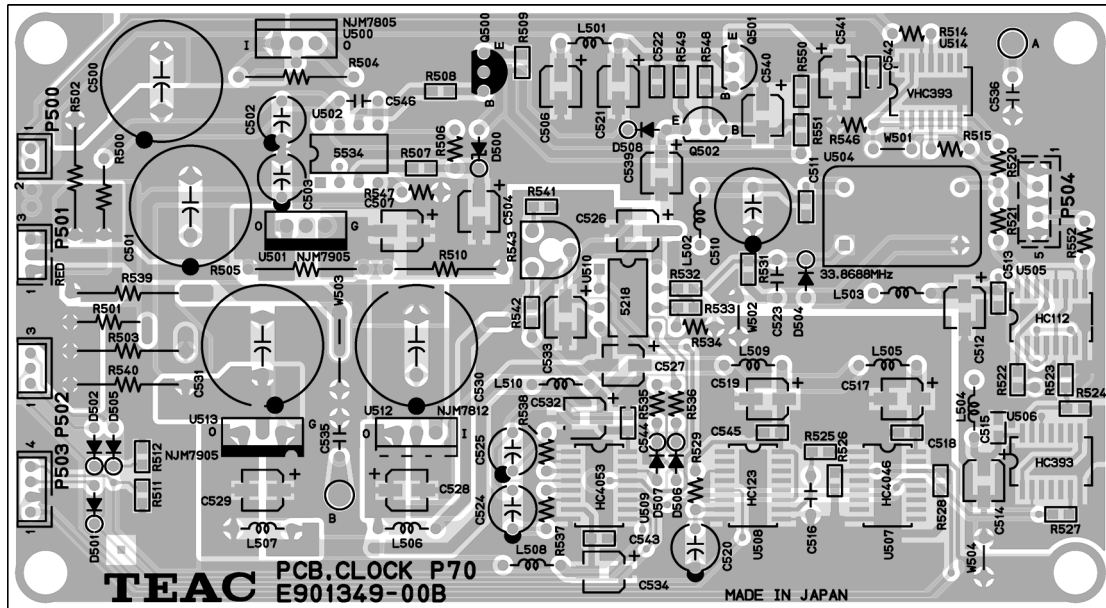

This PCB is a four-layered board.

SERVO PCB ASSY

REF. NO.	PARTS NO.	DESCRIPTION
D404-D406 L401	E95063120A	PCB ASSY, SERVO
	E90063110A	PCB, SERVO
	* 5555590000	EARTH PLATE A
	13411644	DIODE, CHIP 1SS355
	5347027700	FERRITE BEADS, BK2125HS121
L402	E0021764	COIL, LQH3N 10UH
L404	5347027700	FERRITE BEADS, BK2125HS121
P401	5336300000	CONN SKT, 00-8370-207-
P402	5336380800	CONN PLUG, S10BPHSM3TB
P403	E0034074	CONNECTOR, S4BZRSM3ATF
P404, P405	E0034054	CONNECTOR, S2BZRSM3ATF
P406, P407	E0034064	CONNECTOR, S3BZRSM3ATF
P408	E0034074	CONNECTOR, S4BZRSM3ATF
P409	13153072	CONNECTOR, 16P
P410	13153074	CONNECTOR, 18P
P411	5336380600	CONN PLUG, S8BPHSM3TB
P412	E0034134	CONNECTOR, S10BZRSM3ATF
P413	E0034114	CONNECTOR, S8BZRSM3ATF
P414	E0034054	CONNECTOR, S2BZRSM3ATF
P415	E0034114	CONNECTOR, S8BZRSM3ATF
P416	E0034104	CONNECTOR, S7BZRSM3ATF
P417	5336249200	CONN PLUG, B02B-PH-K-S W
P418	5334084200	CONN PLUG, S03B-ZR W
Q401	13427450	TR, 2SA1369G
Q402	S0001224	TR, DTC114EUA
Q403	13427337	TR, 2SC2412K
Q404	S0019894	TR, DTA114EUA-T106
U401	S0018314	IC, CXA1571N-T4
U402	S0018323	IC, CXD2545Q
U403	13445091	IC, TA8406P
U404, U405	S0018334	IC, TA8406F (EL)
U406, U407	13448002	IC, M5218FP-73A
U408	S00370900A	IC, UPD75P218GF-3BP
U409	S0017070	IC, LB1648
U410	13444419	IC, 74HC32F
U411	S0021424	IC, HD74HC00FPEL
U412	5220093600	IC, TC74HCU04AF-TP2
U413	13448002	IC, M5218FP-73A
V403	5280021100	VR, SEMI-FIXED 4.7KB
X402	5347017700	OSC, EF0-EC4194A4
Z401, Z402	S0018364	ZENER DIODE, UDZ 6.2B
Z403	S0018374	ZENER DIODE, UDZ 9.1B

C-MOTOR PCB ASSY

REF. NO.	PARTS NO.	DESCRIPTION
	E95027200A	PCB ASSY, C-MOTOR
	E90027200A	PCB, C-MOTOR

T-MOTOR PCB ASSY

REF. NO.	PARTS NO.	DESCRIPTION
	E95027100A	PCB ASSY, T-MOTOR
	E90027100A	PCB, T-MOTOR

DIRECTION PCB ASSY

REF. NO.	PARTS NO.	DESCRIPTION
	E00586200A	PCB ASSY, DIRECTION
	E90027400A	PCB, DIRECTION
U551, U552	5228017700	PHOTO-INTERRUPTER, GP2S24

SENSOR PCB ASSY

REF. NO.	PARTS NO.	DESCRIPTION
	E95027300A	PCB ASSY, SENSOR
	E90027300A	PCB, SENSOR
	5228014100	PHOTO-INTERRUPTER, GP1A51HR

AC-IN PCB ASSY Part of GATHER PCB A ASSY

REF. NO.	PARTS NO.	DESCRIPTION
	E95134700A	PCB ASSY, AC-IN
	E90134700C	PCB, AC-IN
	* 5555590000	EARTH PLATE A
C001, C002	△ E0022570	SPK KILLER, 0.0047UF 250V
C100, C101	5260466210	CE, 2200UF 25V M AU
C104	C0037352	CE, 100UF 10V M SS
C106, C107	5260463420	CE, 100UF 50V M AU
C108	5260528520	CE, 10UF 25V M SC
C111, C113	C0037352	CE, 100UF 10V M SS
C115, C116	5260528520	CE, 10UF 25V M SC
C120	C0037352	CE, 100UF 10V M SS
D100	5224584921	ZENER DIODE, RD5.1ESB2
J001	△ 5292813500	EMIFLTR, 06ME3 6A 115/250V
L001, L002	△ 5292806300	NOISE FILTER, FK0B16MH13
L100, L101	5286033920	CHC, 10UH K (LAP2T)
L103	5320046300	TRANS, PULSE TC-1027-04
L104, L105	5347027620	FERRITE BEADS, FBR07HA850
L106	5286033920	CHC, 10UH K (LAP2T)
P001, P002	5336374300	CONN PLUG, B3P-VH
P100	5336249300	CONN PLUG, B03B-PH-K-S W
P101, P102	5336249200	CONN PLUG, B02B-PH-K-S W
P103, P104	5336249800	CONN PLUG, B08B-PH-K-S W
Q100	5230012920	TR, 2SA1015GR
R100, R101	△ R0107490	RN, 2W 180 OHM J
R102, R103	△ 5241634920	R, METAL 10 OHM J PR01
R104, R105	△ R0107490	RN, 2W 180 OHM J
R110	△ R0107490	RN, 2W 180 OHM J
S001	△ 5300054700	SW, PUSH SDDL1166A
U100	△ 13447943	IC, NJM78M05FA
U101	△ 13447961	IC, NJM79M05FA
U102	5220444100	IC, NE5534AN
U103	S0047520	IC, TC74HCT74AP
U104	5220051800	IC, TC74HC04AP
U105	5220100300	IC, TC74HCT04P
U106, U107	5292807920	EMIFLTR, EXC EMT 47PFT

WORD-IN PCB ASSY Part of GATHER PCB A ASSY

REF. NO.	PARTS NO.	DESCRIPTION
	E95135100A	PCB ASSY, WORD-IN
	E90135100B	PCB, WORD-IN
	* 5555590000	EARTH PLATE A
	13180156	TERMINAL
C306-C309	5260463120	CE, 100UF 16V M AU
C310, C311	5260466710	CE, 3300UF 16V M AU
C314, C315	5260466710	CE, 3300UF 16V M AU
C320, C321	5260463120	CE, 100UF 16V M AU
C402	5260466210	CE, 2200UF 25V M AU
C405	C0037352	CE, 100UF 10V M SS
C419	C0037352	CE, 100UF 10V M SS
C421, C422	C0037352	CE, 100UF 10V M SS
C427-C429	5260461520	CE, 10UF 25V M AU
C431	C0037352	CE, 100UF 10V M SS
D300-D303	5224018120	DIODE, FEID-G23(TA)
D304-D308	5224015020	DIODE, 1SS133T-77
D309, D310	5224583121	ZENER DIODE, RD3. 3ESB1
D402-D405	5224015020	DIODE, 1SS133T-77
D406	5224585421	ZENER DIODE, RD5. 6ESB3
D407	5224015020	DIODE, 1SS133T-77
J400	E0033060	JACK, P2360 BNC2P(1SW)
L401-L404	5286034720	CHC, 47UH K(LAP2T)
P300	5336249200	CONN PLUG, B02B-PH-K-S W
P301	5336303300	CONN PLUG, B3B-EH(WHT)
P302	5336303900	CONN PLUG, B9B-EH(WHT)
P303	5336249700	CONN PLUG, B07B-PH-K-S W
P400	5336249800	CONN PLUG, B08B-PH-K-S W
P401	5336249400	CONN PLUG, B04B-PH-K-S
P402	5336251200	CONN PLUG, B02B-PH-K-R R
P403	5336249200	CONN PLUG, B02B-PH-K-S W
Q300, Q301	S0044990	TR, 2SD2012
Q302, Q303	S0044980	TR, 2SB1375
Q304	5230775020	TR, 2SC2878B
Q400	5230779520	TR, 2SC1815GR
Q401	5232254820	TR, DTA124ESA
Q402	5232255720	TR, DTC124ESA
Q403	5230779520	TR, 2SC1815GR
R314-R317	△ 5241633320	R, METAL 2.2 OHM J PR01
R320-R323	△ 5241633320	R, METAL 2.2 OHM J PR01
R402	△ R0107450	RN, 2W 120 OHM J
S400	5300918300	SW, SLIDE SSSF1 1-2A
U300, U301	5220448200	IC, NJM2114D
U302-U304	5220418800	IC, M5218P
U402	△ 13447943	IC, NJM78M05FA
U405	S0021414	IC, TC74VHCT04
U406	5220056200	IC, TC74HC393AP
U407	5220053300	IC, TC74HC4053AP
U408	5220054500	IC, TC74HC123AP

TRY-LED PCB ASSY Part of GATHER PCB A ASSY

REF. NO.	PARTS NO.	DESCRIPTION
	E95135500A	PCB ASSY, TRY-LED
	E90135500B	PCB, TRY-LED
D90	S0023580	LED, LNG901CF9 (BLUE)
P90	5336249200	CONN PLUG, B02B-PH-K-S W

FL KEY PCB ASSY Part of GATHER PCB B ASSY

REF. NO.	PARTS NO.	DESCRIPTION
	E95134600A	PCB ASSY, FL KEY
	E90134600A	PCB, FL KEY
	* 5555590000	EARTH PLATE A
	M00539300A	HOLDER ASSY, FL
	5801550500	SPCR, LH-5 L=16.0
C01, C02	5260462620	CE, 47UF 16V M AU
D01, D02	5224015020	DIODE, 1SS133T-77
D03, D04	S0036900	LED, L-934MBT (BLUE)
P01	E0068110	CONNECTOR, DIP6208-18P
P02	E0068100	CONNECTOR, DIP6208-16P
P03	13121314	CONN PLUG, S3B-EH
P04	5336249200	CONN PLUG, B02B-PH-K-S W
Q01-Q04	5232255620	TR, DTC114ESA
SW01-SW06	5302108600	SW, TACT SKHVBE
U01	S00448100A	IC, UPD754302GS-136
U02	E0048220	RMT CONT RCVR, SBX1810-52
U03	E00690000A	IND TUBE, CM2040G
X01	5347012000	OSC, CERAMIC CST4, 19MGW

LED PCB ASSY Part of GATHER PCB B ASSY

REF. NO.	PARTS NO.	DESCRIPTION
	E95135400A	PCB ASSY, LED
	E90135400A	PCB, LED
	M00404700A	SPACER, LED LH-5 L=8
D70-D72	S0036900	LED, L-934MBT (BLUE)

REAR TGL-SW PCB ASSY Part of GATHER PCB B ASSY

REF. NO.	PARTS NO.	DESCRIPTION
	E95135300A	PCB ASSY, REAR TGL-SW
	E90135300A	PCB, REAR TGL-SW
SW80-SW82	13223118	SW, TOGGLE 8A1011

FRONT TGL-SW PCB ASSY Part of GATHER PCB B ASSY

REF. NO.	PARTS NO.	DESCRIPTION
	E95135200A	PCB ASSY, FRONT TGL-SW
	E90135200A	PCB, FRONT TGL-SW
SW60-SW62	13223118	SW, TOGGLE 8A1011

PWR PCB ASSY Part of GATHER PCB B ASSY

REF. NO.	PARTS NO.	DESCRIPTION
	E95134800A	PCB ASSY, PWR [US, C]
	E95134850A	PCB ASSY, PWR [E]
	E90134800A	PCB, PWR
	*5555590000	EARTH PLATE A
	13180156	TERMINAL
	*M00350800A	HEATSINK, OSH-2435-SPL
	*5780023008	SCREW, BPA 3X8 NB
	*5780222606	SCREW, FLAT M2. 6X6 NB
C203, C204	△ C0033090	CE, 6800UF 50V M X-PRO
C208, C209	△ C0033090	CE, 6800UF 50V M X-PRO
C210, C211	5260531420	CE, 100UF 20V M SA
C212	△ 5260464610	CE, 330UF 50V M AU
C213	5260463420	CE, 100UF 50V M AU
C214	5260462620	CE, 47UF 16V M AU
C215	5260462920	CE, 47UF 50V M AU
C220, C221	△ 5260528520	CE, 10UF 25V M SC
C230	5260464720	CE, 470UF 6.3V M AU
D200-D207	△ 5224018120	DIODE, FEID-G23(TA)
D210	△ 5224018120	DIODE, FEID-G23(TA)
D211	5224592821	ZENER DIODE, RD33ESB1
D212	5224585621	ZENER DIODE, RD6.2ESB1
F200-F203	E0034560	CLIP FUSE, H0446
F200-F203	△ E0077810	FUSE, 2.0A T-LAG [US, C]
F200-F203	△ E0077630	FUSE, 2.0A T-LAG [E]
J200	E00353701A	JACK, RCA 1P WHITE NICKING
J201, J202	S0046400	IC, GP1FA551TZ
L200, L201	5286033920	CHC, 10UH K(LAP2T)
P200	5336303300	CONN PLUG, B3B-EH(WHT)
P201	5336303700	CONN PLUG, B7B-EH(WHT)
P202	5336305300	CONN PLUG, B3B-EH-R(RED)
P203	5336287200	CONN PLUG, S2B-PH-K-S W
P204	5336287700	CONN PLUG, S7B-PH-K-S W
P205	5336249300	CONN PLUG, B03B-PH-K-S W
P206	5336249800	CONN PLUG, B08B-PH-K-S W
P207	5336287500	CONN PLUG, S5B-PH-K-S W
P208, P209	5336291300	CONN PLUG, S3B-PH-K-R R
P210	5336251800	CONN PLUG, B08B-PH-K-R R
Q200	△ 5230509100	TR, 2SB562C
S200	5300918300	SW, SLIDE SSSF1 1-2A
U200	△ 13447943	IC, NJM78M05FA
U201	△ 13447961	IC, NJM79M05FA

UP-CON PCB ASSY Part of GATHER PCB C ASSY

REF. NO.	PARTS NO.	DESCRIPTION
	E95135000A	PCB ASSY, UP-CON
	E90135000B	PCB, UP-CON
	*M01421500A	HEATSINK
	*5783533008	SCREW, BPB 3X8 NB
	*5780222606	SCREW, FLAT M2. 6X6 NB
C600	C0038330	CE, 2200UF 25V M LXZ
C601	5260465610	CE, 1000UF 25V M AU
C602	5260462720	CE, 47UF 25V M AU
C604, C605	5260462720	CE, 47UF 25V M AU
C606	C0037352	CE, 100UF 10V M SS

UP-CON PCB ASSY Part of GATHER PCB C ASSY

REF. NO.	PARTS NO.	DESCRIPTION
C607	5260462720	CE, 47UF 25V M AU
C609	5260465610	CE, 1000UF 25V M AU
C615, C619	C0037352	CE, 100UF 10V M SS
C622, C627	C0036264	CE, 47UF 10V M SVP
C629, C631	C0036264	CE, 47UF 10V M SVP
C633, C635	C0036264	CE, 47UF 10V M SVP
C637, C639	C0036264	CE, 47UF 10V M SVP
C641	C0037380	CE, 560UF 4V M SEP
C645, C647	C0036264	CE, 47UF 10V M SVP
C649, C651	C0036264	CE, 47UF 10V M SVP
C653, C658	C0036264	CE, 47UF 10V M SVP
C660, C662	C0036264	CE, 47UF 10V M SVP
C674	C0036264	CE, 47UF 10V M SVP
C685-C690	5260461520	CE, 10UF 25V M AU
C701, C704	C0036264	CE, 47UF 10V M SVP
C705, C707	C0036264	CE, 47UF 10V M SVP
C708	5260462720	CE, 47UF 25V M AU
C709	5260464910	CE, 470UF 16V M AU
C713	C0036264	CE, 47UF 10V M SVP
C714	5260461120	CE, 1UF 50V M AU
D600	5224584921	ZENER DIODE, RD5.1ESB2
D603	5224585421	ZENER DIODE, RD5.6ESB3
D604	5224583821	ZENER DIODE, RD3.9ESB2
D605	5224583121	ZENER DIODE, RD3.3ESB1
D700	5224015020	DIODE, 1SS133T-77
J600, J601	5334078800	CONNECTOR, XLM-3-32PCV
J602	E00353701A	JACK, RCA 1P WHITE NICKING
L600-L603	5286033920	CHC, 10UH K(LAP2T)
L605-L607	5286033920	CHC, 10UH K(LAP2T)
L610	5286033920	CHC, 10UH K(LAP2T)
L611	5347027620	FERRITE BEADS, FBR07HA850
L700, L701	5286033920	CHC, 10UH K(LAP2T)
P600	5336250000	CONN PLUG, B10B-PH-K-S W
P601	5336249500	CONN PLUG, B05B-PH-K-S W
P602	E0069730	CONNECTOR, B05P-MQ
P700	5336249400	CONN PLUG, B04B-PH-K-S
P701	5336251400	CONN PLUG, B04B-PH-K-R R
P702	5336249500	CONN PLUG, B05B-PH-K-S W
P703	5336249800	CONN PLUG, B08B-PH-K-S W
P704	5336249300	CONN PLUG, B03B-PH-K-S W
P705	5336249200	CONN PLUG, B02B-PH-K-S W
P706	5336249700	CONN PLUG, B07B-PH-K-S W
Q600	5230014000	TR, 2SA1020Y
Q603, Q604	5230012920	TR, 2SA1015GR
Q605, Q606	5232255720	TR, DTC124ESA
Q700, Q701	5232254720	TR, DTA114ESA
Q702, Q704	5232255720	TR, DTC124ESA
Q705	5230012920	TR, 2SA1015GR
Q706	5232255720	TR, DTC124ESA
R600, R601	△ R0107330	RN, 2W 39 OHM J
R604, R605	△ R0107330	RN, 2W 39 OHM J
R609, R610	△ R0107330	RN, 2W 39 OHM J
R614	R0102131	RN, 1/4W 120 OHM FC SN2C
R620	R0102131	RN, 1/4W 120 OHM FC SN2C
R682	R0102181	RN, 1/4W 200 OHM FC SN2C

UP-CON PCB ASSY Part of GATHER PCB C ASSY

REF. NO.	PARTS NO.	DESCRIPTION
R687	R0102131	RN, 1/4W 120 OHM FC SN2C
R709	△ R0107190	RN, 2W 10 OHM J
T600, T601	E00595800A	TRANS, PULSE 400UH
T602	5320046300	TRANS, PULSE TC-1027-04
U600	S0046903	IC, XC2S200-5PQ208C
U601	S00464900B	IC, RD0T DF OTPROM
U602-U604	S0021414	IC, TC74VHCT04
U605, U606	S0019640	IC, TC74VHC157F
U608-U610	S0046910	IC, AK4103
U613	△ 13447943	IC, NJM78M05FA
U614	△ 13447961	IC, NJM79M05FA
U615	5220444100	IC, NE5534AN
U620-U625	5292807920	EMIFLTR, EXC EMT 47PFT
U626	S0046400	IC, GP1FA551TZ
U627, U628	△ S0038210	IC, NJM317F
U700	S0046453	IC, UPD78F0058
U701	S0024464	IC, M62001FP-600D
U702	S0021414	IC, TC74VHCT04
U703	△ 13447943	IC, NJM78M05FA
U704	S0021414	IC, TC74VHCT04
X700	E0048054	RESONATOR, 5MHZ EF0S

CLOCK PCB ASSY Part of GATHER PCB C ASSY

REF. NO.	PARTS NO.	DESCRIPTION
	E95134900A	PCB ASSY, CLOCK
	E90134900B	PCB, CLOCK
C500, C501	5260466210	CE, 2200UF 25V M AU
C502, C503	5260463420	CE, 100UF 50V M AU
C504	C0036264	CE, 47UF 10V M SVP
C506, C507	C0036264	CE, 47UF 10V M SVP
C510	C0037352	CE, 100UF 10V M SS
C512, C514	C0036264	CE, 47UF 10V M SVP
C517, C519	C0036264	CE, 47UF 10V M SVP
C520	5260461120	CE, 1UF 50V M AU
C521	C0036264	CE, 47UF 10V M SVP
C524	5260462720	CE, 47UF 25V M AU
C525	5260461520	CE, 10UF 25V M AU
C526-C529	C0036264	CE, 47UF 10V M SVP
C530, C531	5260466210	CE, 2200UF 25V M AU
C532-C534	C0036264	CE, 47UF 10V M SVP
C539-C541	C0036264	CE, 47UF 10V M SVP
D500	5224584921	ZENER DIODE, RD5.1ESB2
D501, D502	5224015020	DIODE, 1SS133T-77
D504-D508	5224015020	DIODE, 1SS133T-77
L501-L510	5286033920	CHC, 10UH K(LAP2T)
P500	5336249200	CONN PLUG, B02B-PH-K-S W
P501	5336251300	CONN PLUG, B03B-PH-K-R R
P502	5336249300	CONN PLUG, B03B-PH-K-S W
P503	5336249400	CONN PLUG, B04B-PH-K-S
P504	E0069720	CONNECTOR, 05MQ-BT
Q500	5230012920	TR, 2SA1015GR
Q501, Q502	5230779520	TR, 2SC1815GR
R500, R501	△ 5241637020	R, METAL 75 OHM J PR01
R502-R505	△ R0107370	RN, 2W 56 OHM J

CLOCK PCB ASSY Part of GATHER PCB C ASSY

REF. NO.	PARTS NO.	DESCRIPTION
R510	△ R0107370	RN, 2W 56 OHM J
R539, R540	△ R0107370	RN, 2W 56 OHM J
R543	5280020700	VR, SEMI-FIXED 1KB
U500	△ 13447943	IC, NJM78M05FA
U501	△ 13447961	IC, NJM79M05FA
U502	5220444100	IC, NE5534AN
U504	E0041020	VCO, 33.8688M/150PPM
U505	S0031483	IC, TC74HC112AF
U506	13443599	IC, 74HC393
U507	5220123500	IC, MC74HC4046AF-FR1
U508	13443917	IC, HD74HC123FP
U509	13445580	IC, HD74HC4053FP
U510	5220418800	IC, M5218P
U512	△ 13447943	IC, NJM78M05FA
U513	△ 13447961	IC, NJM79M05FA
U514	S0019650	IC, TC74VHC393F

5 INCLUDED ACCESSORIES

INCLUDED ACCESSORIES

REF. NO.	PARTS NO.	DESCRIPTION	REMARKS
	D00713000A	OWNER'S MANUAL, E/F/S	
	D00714500A	OWNER'S MANUAL, G/I/N [E]	
	E00557910A	REMOTE CONTROL UNIT, RC-890	
	5347007000	BATTERY, UM-3	
	△ 5350018800	POWER CORD SET, 3P [US, C]	
	△ 15922303	POWER CORD SET, 3P [E]	
	* 5801543100	LOCK PLATE	
	* M01499300A	CUSHION, FOOT	