

TEAC®



SERVICE MANUAL

P-9/P-7

Fully-Automatic Direct-Drive Turntable

1 SPECIFICATIONS

Type Fully-automatic system

Drive System

PLL-quartz-locked direct-drive system (P-9)

Direct-drive system (P-7)

Motor DC2-phase 8-pole coreless motor (P-9)

FG servo DC coreless servo motor (P-7)

Turntable

310 mm diameter, aluminium alloy diecast

Speed 33-1/3 and 45 rpm

Pitch Control

±4% (P-7)

Wow and Flutter

0.045% WRMS (P-9)

0.05% WRMS (P-7)

Signal-to-Noise Ratio

65 dB, DIN-B (P-9)

64 dB, DIN-B (P-7)

Tonearm

Type Static balanced, straight tubular arm

Effective Length 227 mm

Tracking Error Angle +2.68°, -1.35°

Overhang 15.8 mm

Stylus Pressure Range 0 – 3g

Usable Cartridge Weight 4 – 10g

***Cartridge**

Type Moving Magnet

Frequency Response 20 – 20,000 Hz

Optimum Stylus Force 1.5 – 2.0g

Output Voltage 3 mV

Channel Separation 25 dB (1 kHz)

Stylus 0.5 mil spherical diamond

Load Impedance 47 kohms

Cartridge Weight 5.5g ±0.5g

Power Requirements

100/120/220/240 V

AC 50/60 Hz (General export model)

120 V AC 60 Hz (U.S.A./Canada)

220 V AC 50 Hz (Europe)

240 V AC 50 Hz (U.K./Australia)

Power Consumption 9 W

Dimensions See Fig. 1-1

Weight 8.6 kg (18-15/16 lbs) net

*U.K. and U.S.A. models are supplied without cartridges.

- Improvements may result in specifications or features changing without notice.

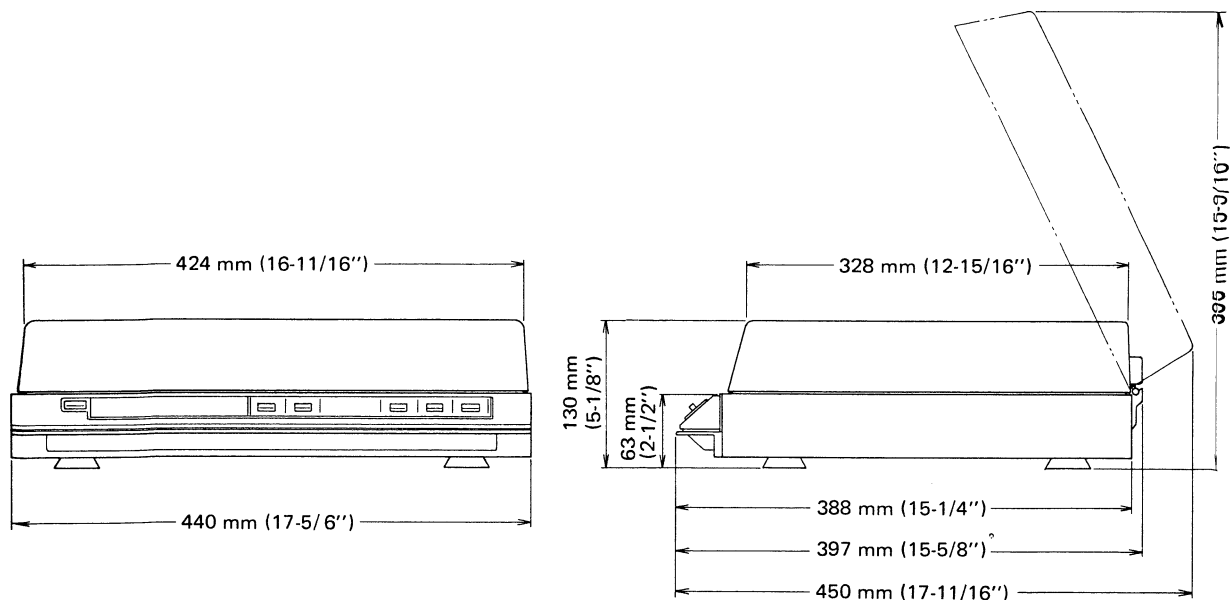

Fig. 1-1 Dimensions

CAUTION

⚠ Parts marked with this sign are safety critical components. They must always be replaced with identical components - refer to the appropriate Parts List and ensure exact replacement.

2 PARTS LOCATION

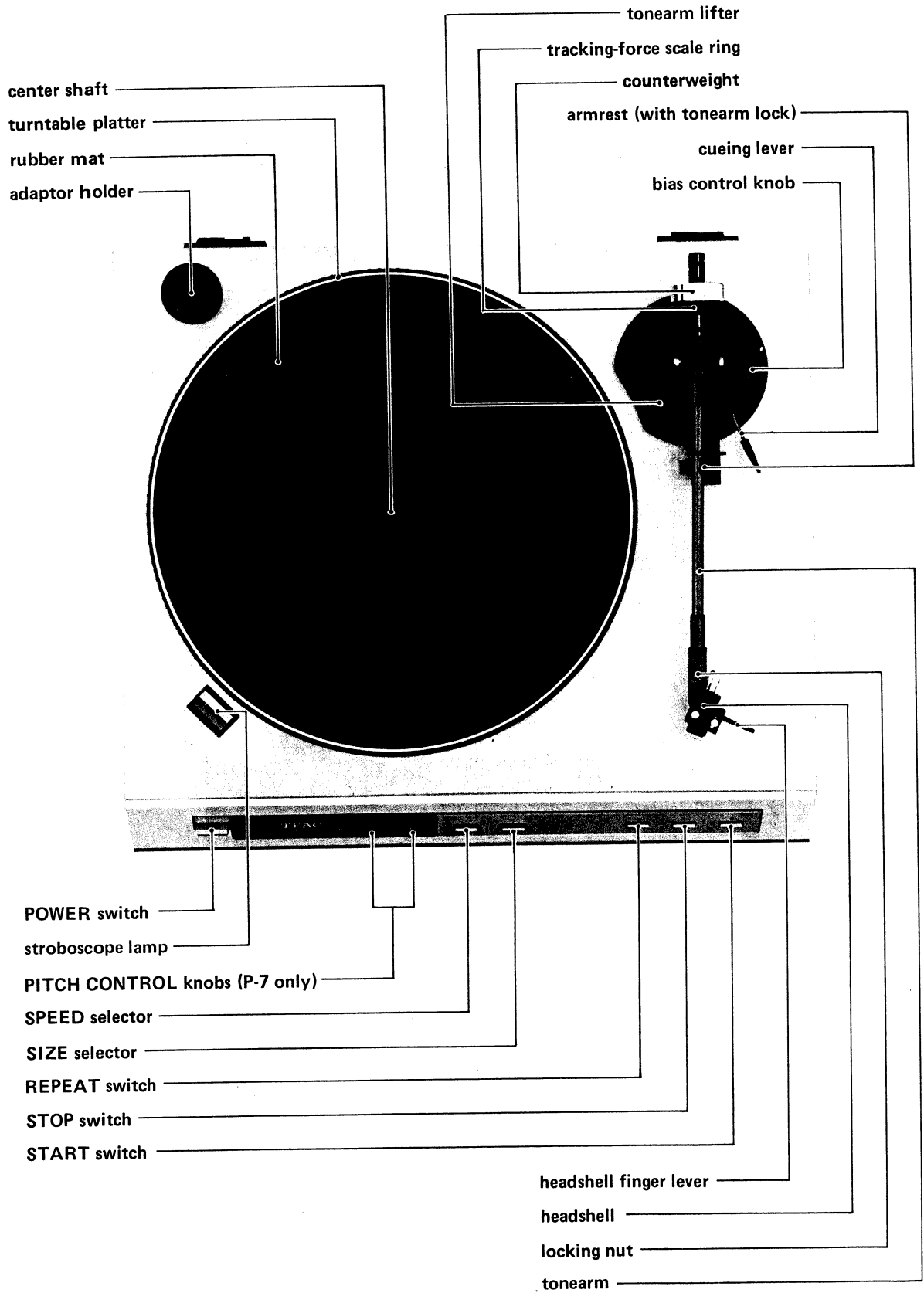

Fig. 2-1

P-9

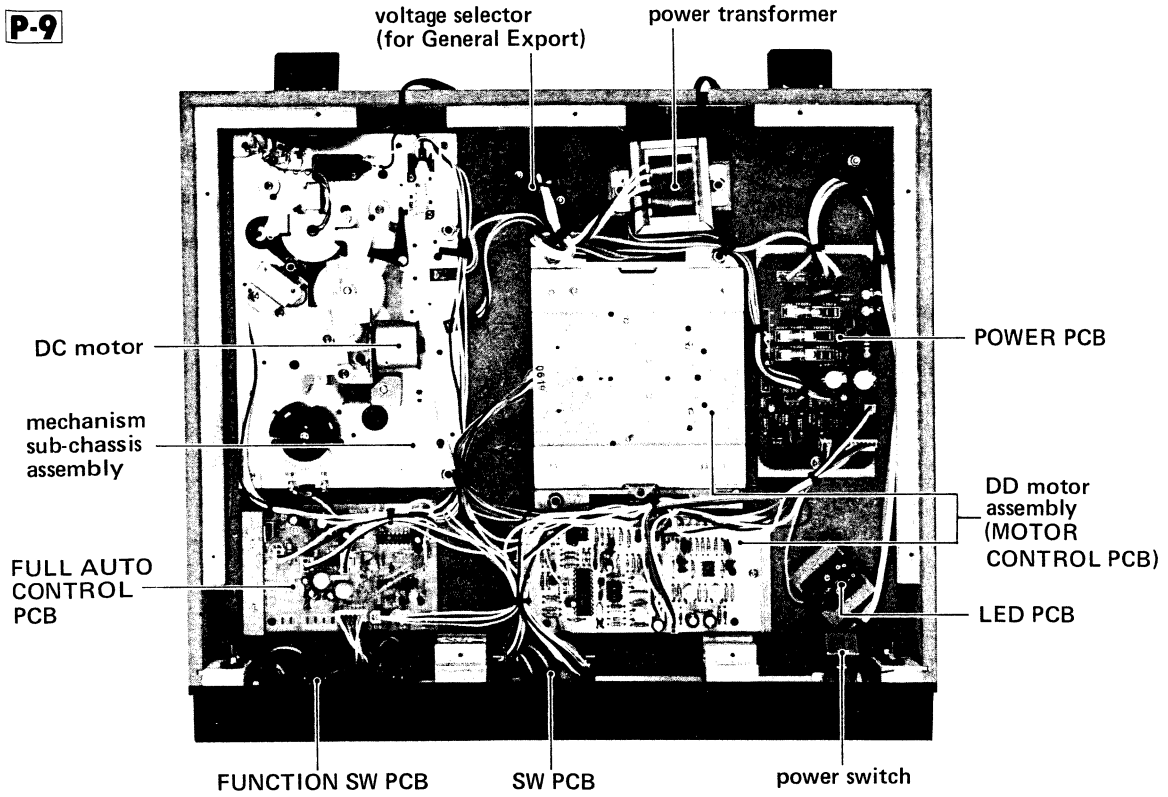

Fig. 2-2

P-7

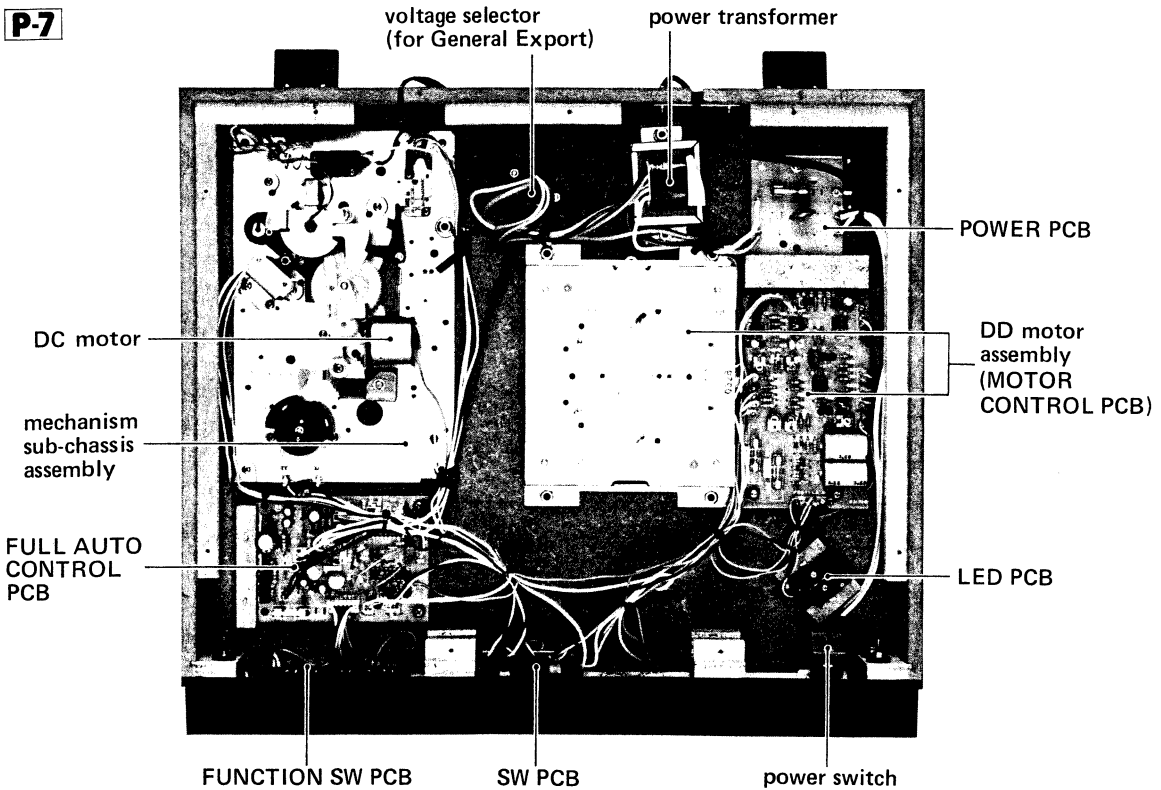

Fig. 2-3

3 DISASSEMBLY INSTRUCTIONS

3-1 DUST COVER

1. Lift up the dust cover.
2. Pull off the dust cover in the direction of the arrow (Fig. 3-1).

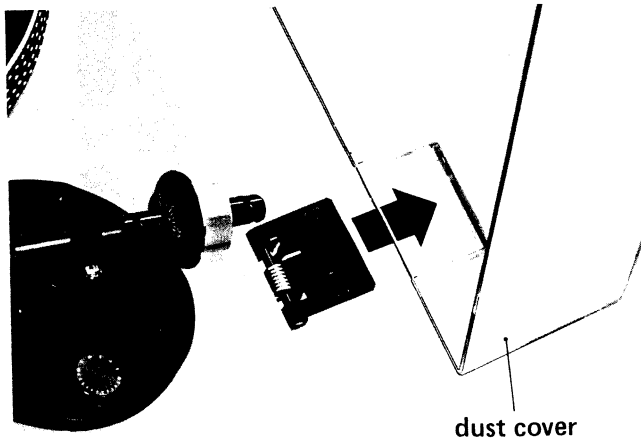

Fig. 3-1

3-2 HEADSHELL

1. Rotate the locking nut at the end of tonearm counterclockwise.
2. Gently extract the headshell assembly from the tonearm.

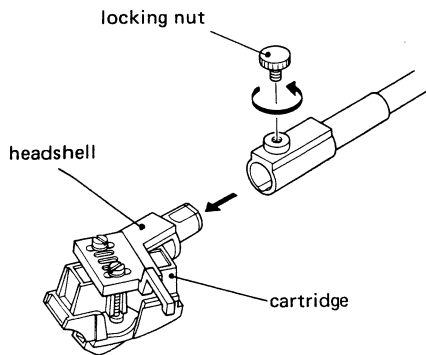

Fig. 3-2

3-3 CARTRIDGE

1. Remove the headshell assembly as described in item 3-2.
2. Disconnect the four connecting tips of the headshell lead wires from the cartridge output pins.
3. Unscrew the two cartridge mounting screws. Remove the cartridge from the headshell.
4. Holding the new cartridge, grasp both sides of the stylus housing, and pull the stylus housing firmly out from the cartridge in the direction indicated by the arrow. Heed these instructions to prevent possibility of bending the stylus tip.
5. Temporarily attach the new cartridge to the headshell by lightly fastening the two cartridge-mounting screws.

6. Attach the four connecting wires to the cartridge output pins. Refer to Fig. 3-4 when remounting the cartridge onto the headshell.
7. Attach the headshell by inserting it into the locking nut at the end of the tonearm and slightly pushing it in the opposite direction of arrow in Fig. 3-2. Rotate the locking nut clockwise and tighten it firmly.
8. Re-attach the stylus housing by firmly sliding it into the cartridge in the opposite direction to the arrow in Fig. 3-3, taking care not to touch the stylus tip.
9. Adjust the overhang referring to item 4-1, then secure the two cartridge-mounting screws. Make sure that the cartridge is not tilted off the center line of the headshell.
10. Fasten the tonearm to the armrest.

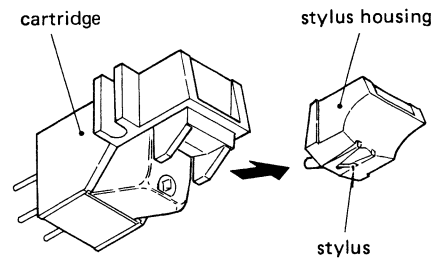

Fig. 3-3

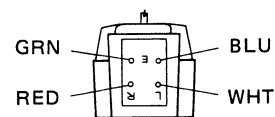
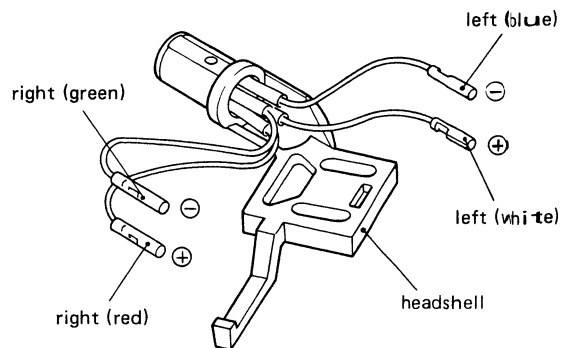

Fig. 3-4

3-4 BOTTOM COVER

1. Lift up the dust cover, then remove the rubber mat and turntable platter.
2. Fasten the tonearm to the armrest.
3. Close the dust cover then turn the turntable upside down.
4. Remove the nine screws from the bottom cover as shown in Fig. 3-5.
5. Carefully pull off the bottom cover.

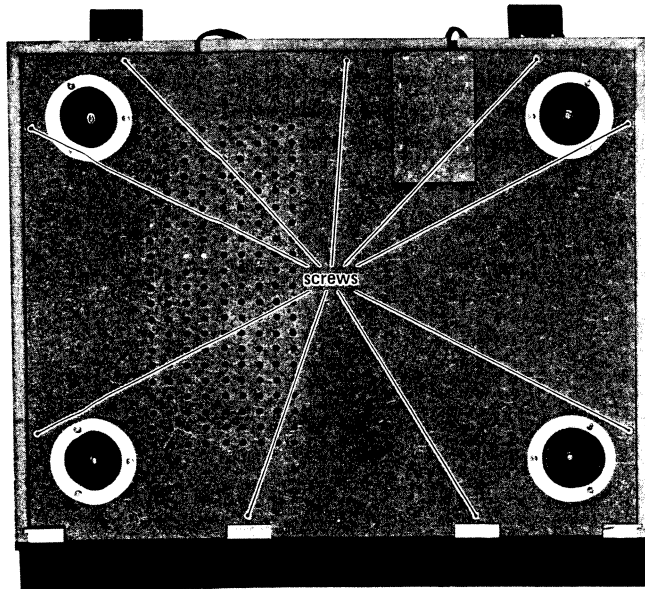

Fig. 3-5

3-5 TONEARM

1. Lock the tonearm to the armrest.
2. Unsolder the pickup lead wires from the terminal strip.
3. Loosen the hexagon set screw marked "A".
4. Remove the feed arm assembly from the tonearm bearing.
5. Referring to Fig. 3-7, loosen the set screw marked "C".
6. The tonearm can be removed when the tonearm lock is released.
7. If necessary, the pickup base assembly can be removed by unscrewing the three screws marked "B" in Fig. 3-6.

Replacement of tonearm

1. Insert the tonearm bearing into the pickup base assembly as far as it will go. Be careful that the pickup lead wires do not get caught between the areas indicated in Fig. 3-8.
2. Secure the tonearm with the tonearm lock.
3. Tighten the set screw marked "C" in Fig. 3-7.
4. Pass the pickup lead wires through the hole of the feed arm assembly.
5. Set the feed arm assembly over the tonearm bearing.
6. Make sure that the tip of the switch arm is positioned so that it fits within the indentation of the main gear as illustrated in Fig. 3-6.
7. Adjust the height of the feed arm assembly referring to paragraph 4-5, steps 1 to 4.
8. Solder each of the pickup wire leads to the corresponding lug of the terminal strip.

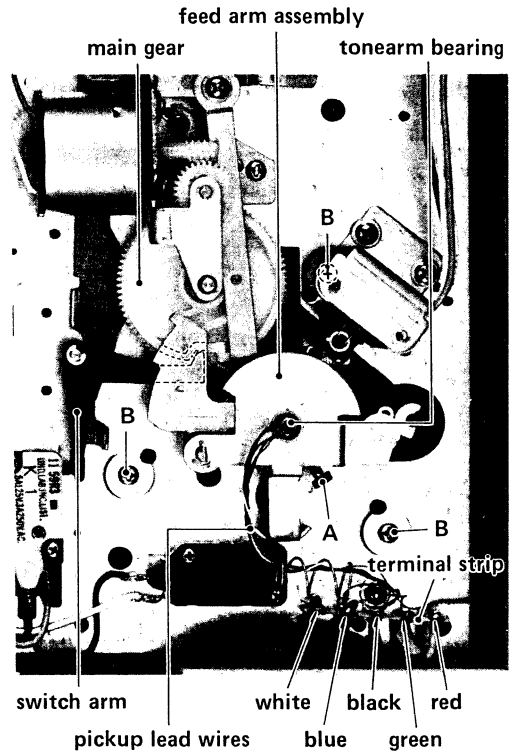

Fig. 3-6

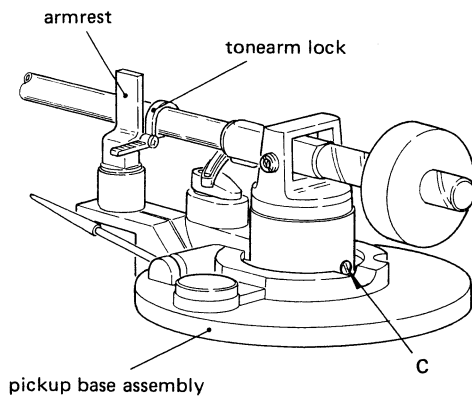

Fig. 3-7

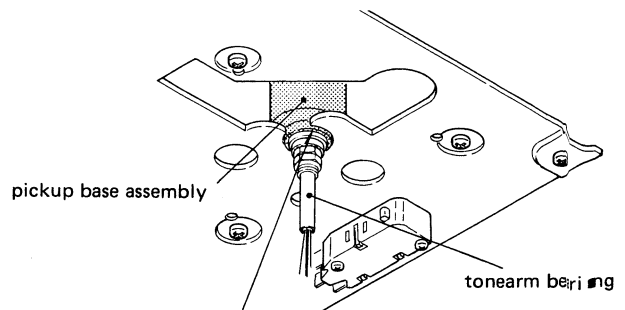

Fig. 3-8

3-6 MOTOR

NOTE: Though the type of motor assembly (including MOTOR CONTROL PCB) differs between the P-9 and P-7, the method of removal is similar.

1. Unscrew the four nuts (B) and the two screws (A) to remove the motor and the MOTOR CONTROL PCB, respectively.
2. To separate the motor itself from its mounting angles, unscrew the four screws (C).

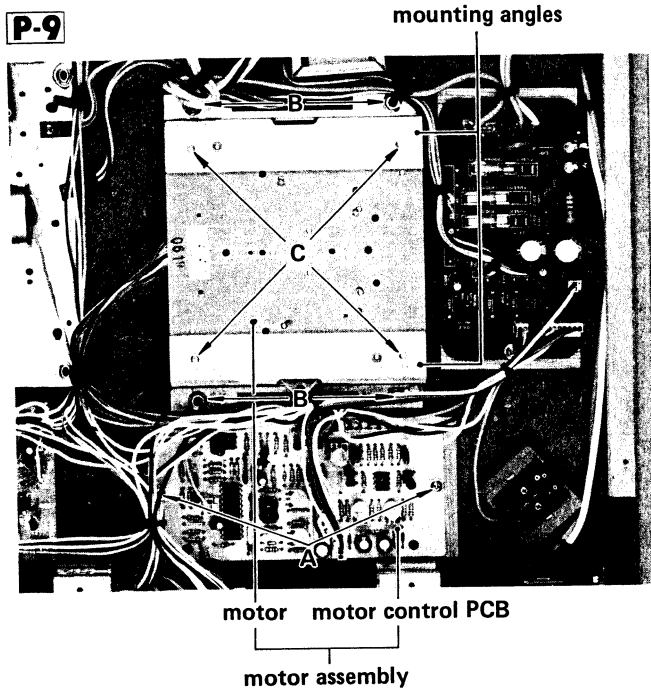

Fig. 3-9

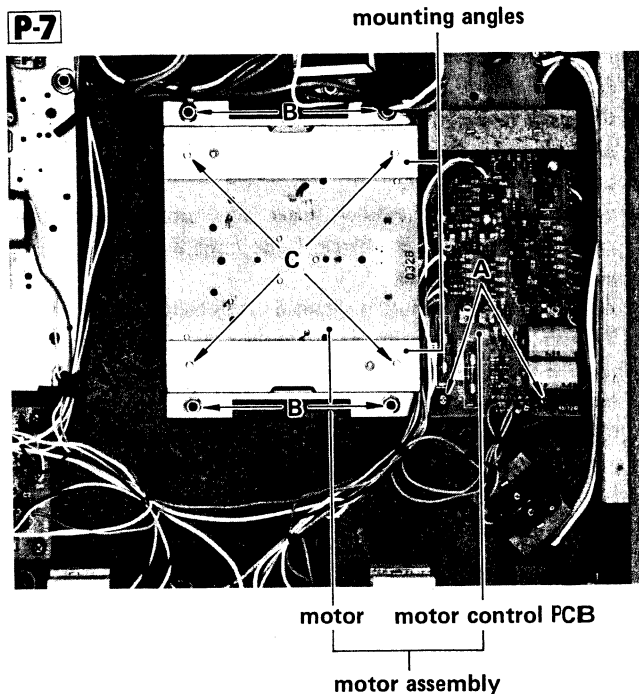

Fig. 3-10

4 ADJUSTMENTS

4-1 STYLUS OVERHANG

The overhang of the tonearm should be 15.8 mm as shown in Fig. 4-2. On models supplied with the cartridge attached to the headshell, the correct overhang has already been factory adjusted.

1. Fit the overhang adjustment card supplied with the P-9/P-7 around the headshell as shown in the illustration.
2. By loosening the screws on the headshell, adjust the position of the cartridge so that the stylus tip is aligned with point (A).
3. After positioning, be sure that the cartridge is parallel to the sides of the headshell before retightening the screws.

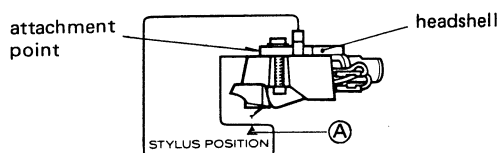

Fig. 4-1 Overhang Adjustment Card

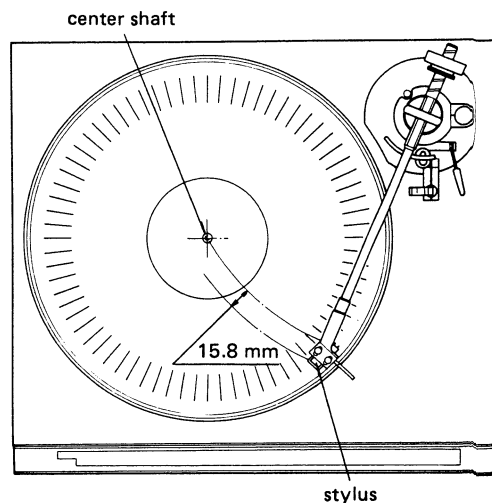

Fig. 4-2

4-2 STYLUS PRESSURE AND ANTI-SKATING

1. Remove the stylus cover and release the tonearm lock.
2. Set the bias control knob to 0.
3. Bring the tonearm to a position between the armrest and turntable.
4. Lower the cueing lever.
5. Gently holding the headshell finger lever, screw the counterweight clockwise or counterclockwise until the tonearm is in perfect horizontal balance.
6. Zero-gram stylus pressure is obtained in this balanced condition, Maintain the setting of the counterweight then turn the tracking force scale ring so that the "0" mark is aligned with the white reference line on the rear of the tonearm.
7. Numerals shown on the scale ring directly indicate the stylus pressure from "0" to "3" grams. After establishing the "zero-reference point", turn the counterweight until the stylus pressure reading corresponds to the cartridge manufacturer's recommendations.

NOTE: The set screw on the counterweight provides adjustment to allow proper travel of the counterweight along the helical threads on the rear of the tonearm. The setting of this screw should not be altered unless there is some difficulty in counterweight travel along the threads.

8. Match the bias control knob setting to correspond to the stylus pressure for the proper anti-skating force.

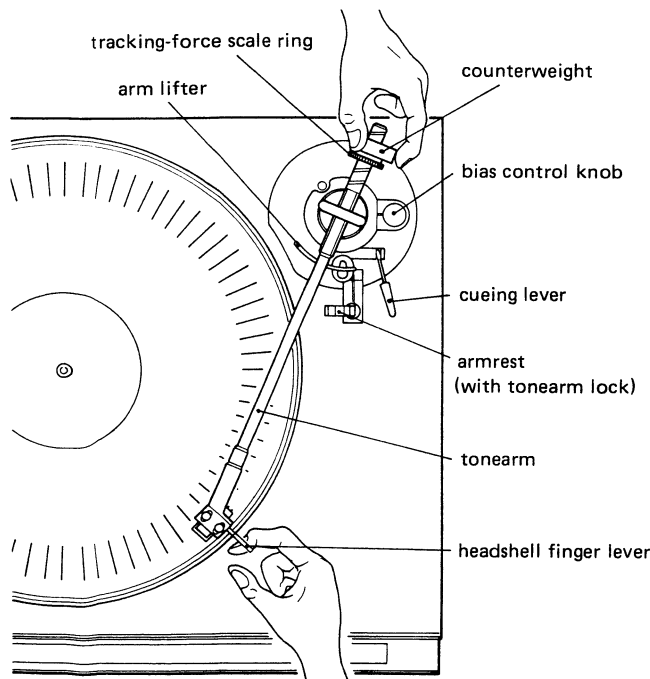

Fig. 4-3

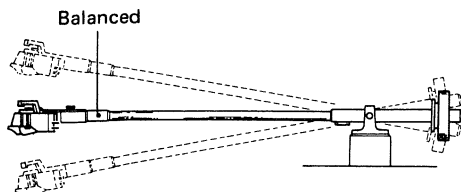

Fig. 4-4

4-3 FULL AUTO CONTROL CIRCUIT

1. Set the POWER switch to ON.
2. Raise the cueing lever and then manually move the tonearm just over the lead-in groove of a record.
3. Select 33-1/3 rpm mode.
4. Adjust the points below on the FULL AUTO CONTROL PCB for the proper voltages.
 VR1: To get 0.2 V DC between pins 7 and 8.
 VR2: To get 0.55 V DC between pins 7 and 9.

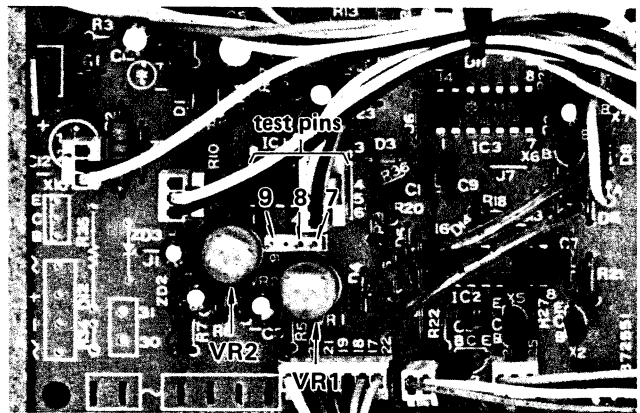

Fig. 4-5 FULL AUTO CONTROL PCB

4-4 TONEARM LIFTER HEIGHT

1. Place any test record on the turntable.
2. Raise the cueing lever, and move the tonearm over the record surface.
3. Adjust the lifter height adjusting nut so that the clearance between the stylus and the record surface is 4 to 13 mm.

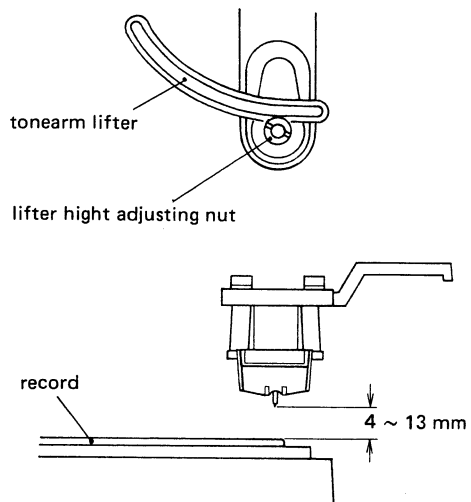

Fig. 4-6

4-5 AUTO RETURN

1. Initially set the two eccentric pins as shown in the upper portion of Fig. 4-7.
2. Adjust the feed arm assembly height with the hexagon set screw (slightly tighten for temporary adjustment) so that the gap between the feed arm assembly and the friction rubber on the rotating lever is 1.4 mm as shown.
3. After securing the tonearm to the armrest, adjust the feed arm assembly position, maintaining the 1.4 mm clearance, so that the actuating pin of the microswitch will be positioned a little to the right side of line A.
4. Securely tighten the hexagon set screw.
5. To fine-adjust the desired tonearm return speed, turn the return eccentric pin clockwise (reducing the speed) or counterclockwise (increasing the speed).

4-6 AUTO LEAD-IN

1. Push the POWER switch to ON.
2. Place a record on the turntable and push the START switch to move the tonearm toward the record.
3. If the tonearm is not automatically brought to the lead-in groove and lowered to begin play (for either 17 cm or 30 cm record size selection), turn the lead-in eccentric pin on the feed arm assembly until proper operation is obtained (refer to Fig. 4-7).
4. Turning the eccentric pin clockwise will adjust the position of the tonearm away from the record and counterclockwise towards the record.

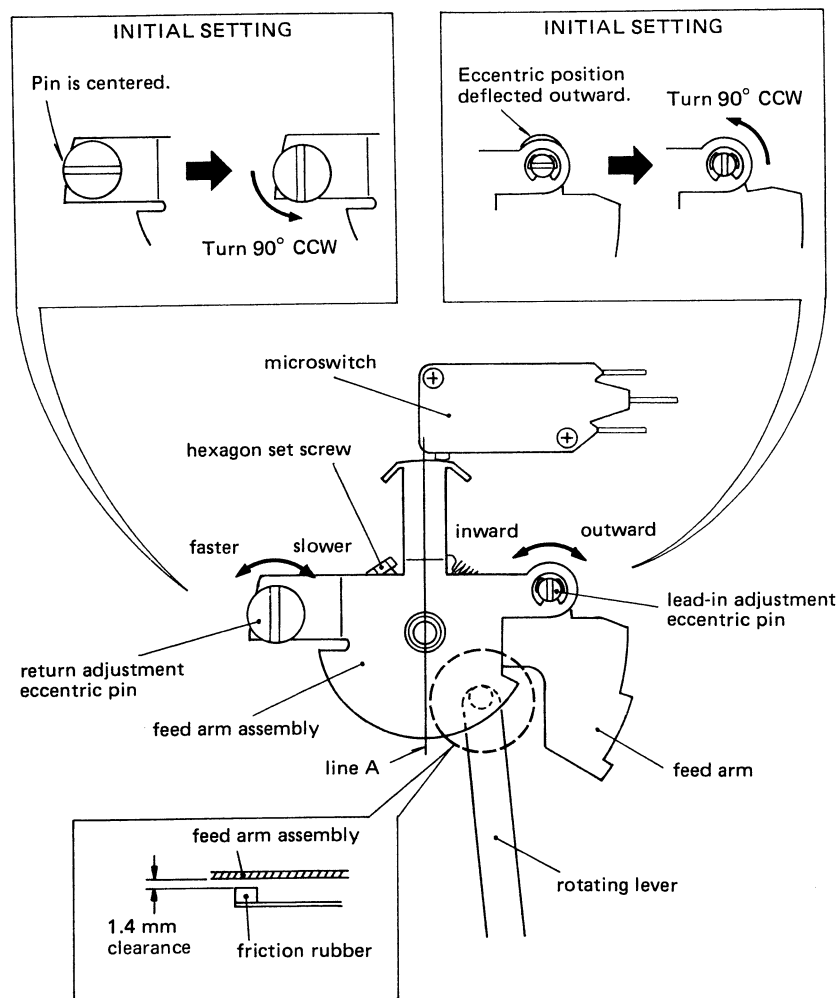

Fig. 4-7

4-7 SIZE SELECTOR SOLENOID POSITIONING

1. Set the POWER switch to ON.
2. Place a suitably-sized record on the turntable.
3. Release the tonearm lock.
4. Press the START switch with the SIZE switch set to "30".
5. Immediately after the tonearm stops after being automatically brought over the lead-in groove, turn the POWER off.
6. Check that there is sufficient clearance between the stylus and the record surface.
7. Adjust the sub-chassis plate position in either direction as shown by the arrow so that the relation of the position between the selector assembly and the feed arm is that as shown at (A) in Fig. 4-8.
8. Set the SIZE switch to "17".
9. Proceed in the similar fashion as in steps 1 to 5.
10. Check that the relationship shown at (B) in Fig. 4-8 is obtained (if correct for 30-cm size, adjustment should not be necessary).

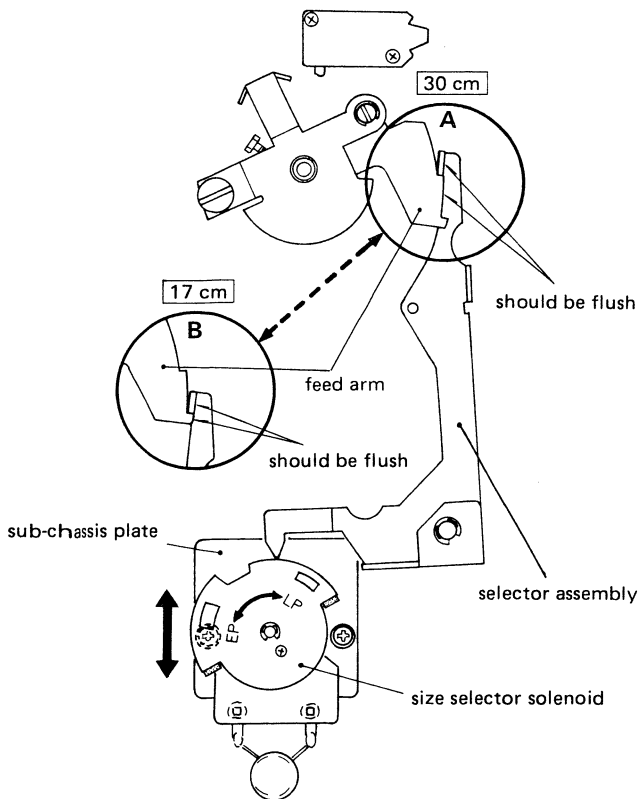

Fig. 4-8

4-8 TURNTABLE SPEED

P-7

1. With the power on, and the turntable platter rotating, set the SPEED selector to the 33-1/3 rpm position.
2. At first, set the PITCH CONTROL knob for 33-1/3 rpm in the "no variation" (midpoint) position.
3. Adjust VR1 on the MOTOR CONTROL PCB so that the strobe markings on the row corresponding to the speed of 33-1/3 rpm and the required voltage frequency appear to be stationary.
4. Using VR2 on MOTOR CONTROL PCB for 45 rpm, adjust as explained above.

P-9

On the P-9, there is no adjustment because a quartz phase-locked loop circuit automatically fine-adjusts the speed within specified tolerances.

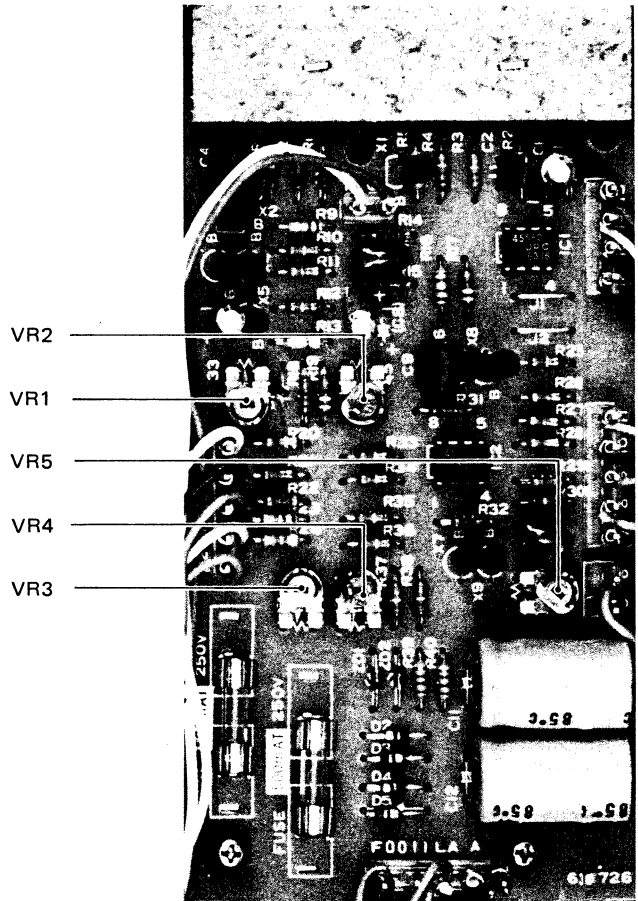

Fig. 4-9 MOTOR CONTROL PCB of P-7

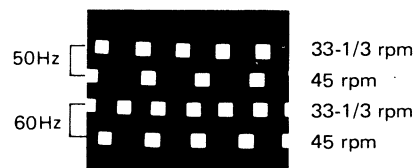

Fig. 4-10 Strobe markings on the outer rim of the platter of the P-7

4-9 WOW AND FLUTTER

NOTE: All adjustors are provided on the MOTOR CONTROL PCB (Figs. 4-9 and 4-12).

P-9

1. Connect a wow and flutter meter as shown in Fig. 4-11.
2. Set the POWER switch to ON.
3. Place a 33-1/3 rpm test record (on which a 3,000 Hz test tone is recorded) on the turntable platter and play it.
4. Watching the pointer of the wow and flutter meter, adjust VR3 so that the pointer shows the minimum value.
5. Then, adjust VR1 and VR2 alternately so that the meter shows the minimum value.
6. The final reading of the wow-and-flutter meter should be less than 0.045% WRMS.

P-7

7. For the P-7, use points VR5, VR3 and VR4 instead of VR3, VR1 and VR2 on the P-9, respectively, and proceed in the same manner as above.
8. The final reading of the wow-and-flutter meter should be less than 0.05% WRMS.

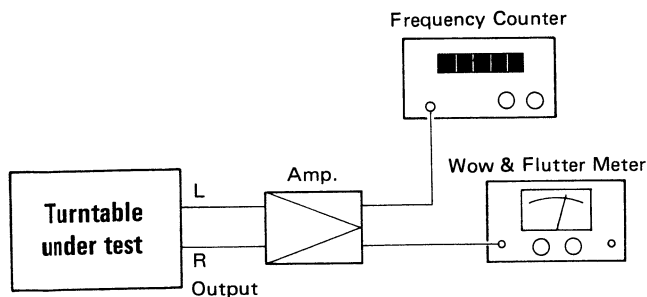

Fig. 4-11

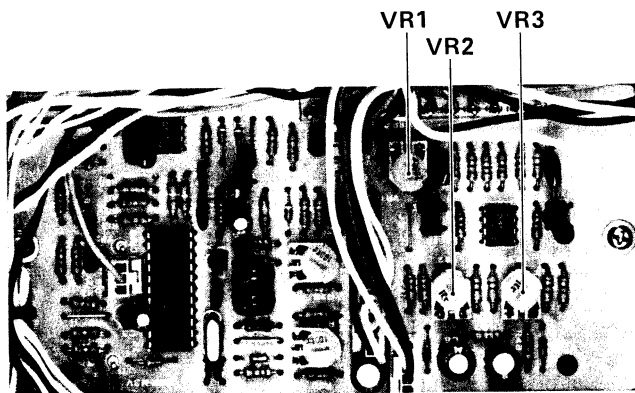

Fig. 4-12 MOTOR CONTROL PCB of P-9

4-10 LUBRICATION

The P-9/P-7 has been designed to minimize maintenance requirements. No part will ever require lubrication and never attempt to do so.

4-11 VOLTAGE SETTING

NOTE: Disconnect mains lead from AC power outlet before making this adjustment.

If the turntable is a general export model, and it is necessary to set the voltage to match the voltage requirements of your area, use a suitably-sized screwdriver and simply turn the dial until the voltage indication (▲ SETTING VOLTAGE) matches the voltage requirement of your area.

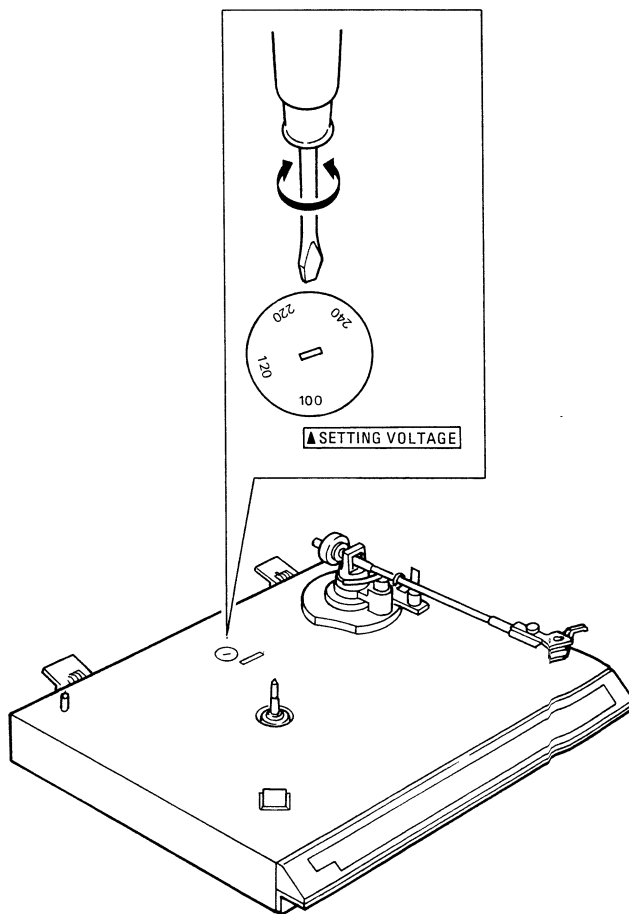
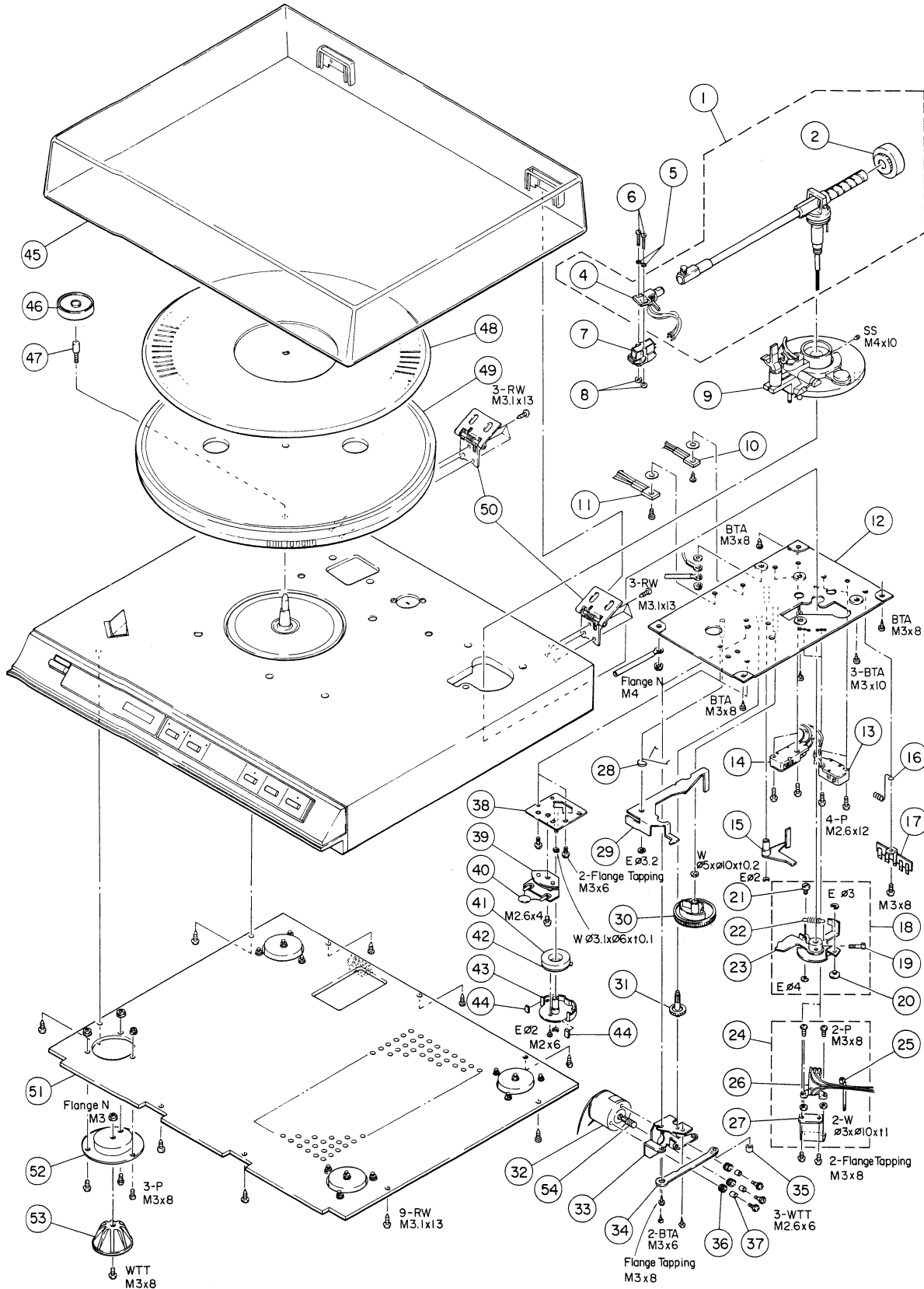

Fig. 4-13

5 EXPLODED VIEWS AND PARTS LIST

EXPLODED VIEW - 1 (P-9)



Parts marked with *require longer delivery time.

REF. NO.	PARTS NO.	DESCRIPTION	REMARKS
1 - 1	*5760051300	Pickup Arm Assy [US, UK]	with Cartridge
1 - 2	*5760051310	Pickup Arm Assy [All except US, UK]	
1 - 3	5760064600	Counterweight (not used)	
1 - 4	5760064700	Headshell	
1 - 5	*5760065000	Washer	
1 - 6	*5760064900	Screw	
1 - 7	5760064800	Cartridge	
1 - 8	*5760065100	Nut	
1 - 9	*5760043500	Pickup Base Assy	
1 - 10	5760062500	Transistor, 2SC1449	Part of 2-25
1 - 11	5760062600	Transistor, 2SB744	Part of 2-25
1 - 12	*5760044800	Sub-chassis Assy, Mechanism	
1 - 13	5760046100	Switch, Micro	
1 - 14	5760046200	Switch, Micro	
1 - 15	*5760046000	Arm, Switch	
1 - 16	*5760043700	Clamper, lead Wire	
1 - 17	*5760055300	Terminal Strip, 5P	
1 - 18	*5760043600	Arm Assy, Feed	
1 - 19	*5781703014	Set Screw, Hexagon	
1 - 20	*5760049500	Eccentric Pin, 2	
1 - 21	*5760049400	Eccentric Pin, 1	
1 - 22	*5760049600	Spring, Arm	
1 - 23	*5760049300	Sub-arm Assy, Feed	
1 - 24	5760050400	Sensor Assy	
1 - 25	*5760055200	Clamper, Cord	
1 - 26	*5760054800	Holder, Sensor	
	*5760054900	LED, GL5PR6	
	*5760055000	Photo Transistor	
1 - 27	*5760055100	Angle, Sensor	
1 - 28	*5760045000	Spring, Select	
1 - 29	*5760044900	Selector Assy	
1 - 30	5760045100	Gear, Main	
1 - 31	5760045200	Gear, 1	
1 - 32	5760045400	Motor Assy, DC	
1 - 33	*5760045500	Bracket, Gear	
1 - 34	*5760045800	Lever Assy, Rotating	
1 - 35	*5760045900	Friction Rubber	
1 - 36	*5760045700	Cushion Rubber	
1 - 37	*5760045600	Tube	
1 - 38	*5760052500	Plate, Sub-chassis	
1 - 39	*5760052900	Solenoid, Size Selector	
1 - 40	*517224800	Capacitor, Mylar 0.1 μ F 50V	
1 - 41	*5760052800	Magnet	
1 - 42	*5760052700	Holder, Magnet	
1 - 43	*5760052600	Cam, Size Selector	
1 - 44	*5760053000	Damper	
1 - 45	*5760044700	Cover, Dust	
1 - 46	*5760057700	Adaptor, EP	
1 - 47	*5760060700	Shaft, Adaptor	
1 - 48	*5760043900	Mat, Rubber [US]	
	*5760044000	Mat, Rubber [All except US]	
1 - 49	*5760043800	Platter, Turntable	
1 - 50	*5760044600	Hinge Assy	
1 - 51	*5760049700	Cover, Bottom	
1 - 52	*5760049800	Holder, Foot	
1 - 53	*5760049900	Foot	
1 - 54	*5760045300	Gear, 2	

[US]: U.S.A. [C]: CANADA [GE]: GENERAL EXPORT [E]: EUROPE [UK]: U.K.
[A]: AUSTRALIA

EXPLODED VIEW - 2 (P-9)

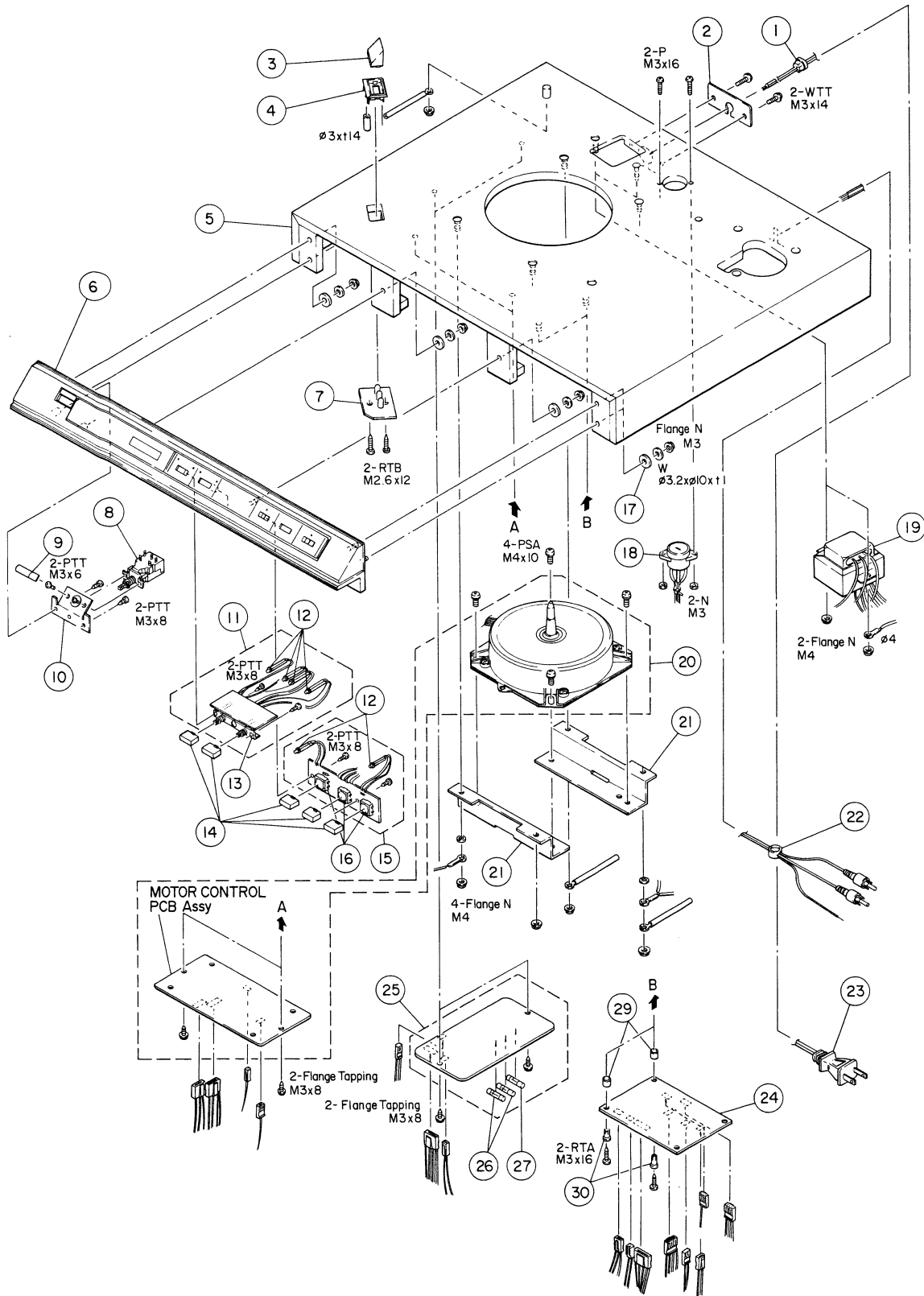

Parts marked with *require longer delivery time.

REF. NO.	PARTS NO.	DESCRIPTION	REMARKS
2 - 1	*5760044300	Strain Relief, A [US, C, GE]	
	*5760044400	Strain Relief, B [E, UK, A]	
2 - 2	*5760044100	Bracket, Strain Relief, A [US, C, GE]	
	*5760044200	Bracket, Strain Relief, B [E, UK, A]	
2 - 3	*5760046500	Prism	
2 - 4	*5760046600	Holder, Prism	
2 - 5	*5760042600	Cabinet, A [US, C]	
	*5760042700	Cabinet, B [GE]	
	*5760042800	Cabinet, C [E, UK, A]	
2 - 6	*5760043100	Plate Assy, Control	
2 - 7	5760050300	PCB Assy, LED	
2 - 8	△ 5760054400	Switch, Power [US, C]	
	△ 5760054500	Switch, Power [All except US, C]	
2 - 9	5760043300	Button, Power	
2 - 10	*5760056400	Bracket, Power Switch	
2 - 11	*5760050200	PCB Assy, SW	
2 - 12	5760053400	LED	
2 - 13	5760053600	Switch, Push (2-gang)	
2 - 14	5760043400	Button, Push	
2 - 15	*5760050100	PCB Assy, FUNCTION SW	
2 - 16	5760053200	Switch, Tact	
2 - 17	*5760043200	Packing	
2 - 18	△ *5760051200	Voltage Selector [GE]	
2 - 19	△ *5760050800	Transformer, Power [US, C]	
	△ *5760050900	Transformer, Power [GE]	
	△ *5760051000	Transformer, Power [E]	
	△ *5760051100	Transformer, Power [UK, A]	
2 - 20	5760067100	Motor Assy, DD	
2 - 21	*5760042900	Angle, Motor	
2 - 22	5760055400	Cord Assy, Pin	
2 - 23	△ *5760052100	Cord, AC Power [US, C, GE]	
	△ *5760052200	Cord, AC Power [E]	
	△ *5760052300	Cord, AC Power [UK]	
	△ *5760052400	Cord, AC Power [A]	
2 - 24	*5760052000	PCB Assy, FULL AUTO	
2 - 25	*5760051500	PCB Assy, POWER [US, C]	incl. 1-10, 1-11
	*5760051510	PCB Assy, POWER [All except US, C]	incl. 1-10, 1-11
2 - 26	△ 5041145000	Fuse, 1A [US, C]	
	△ 5142132000	Fuse, T400mA [All except US, C]	
2 - 27	△ 5142128000	Fuse, T200mA [All except US, C]	
2 - 28		(not used)	
2 - 29	*5760051400	Collar	
2 - 30	*5760051800	Bushing	

MOTOR CONTROL PC Board is not supplied individually.

[US]: U.S.A. [C]: CANADA [GE]: GENERAL EXPORT [E]: EUROPE [UK]: U.K.
[A]: AUSTRALIA

EXPLODED VIEW - 3 (P-7)

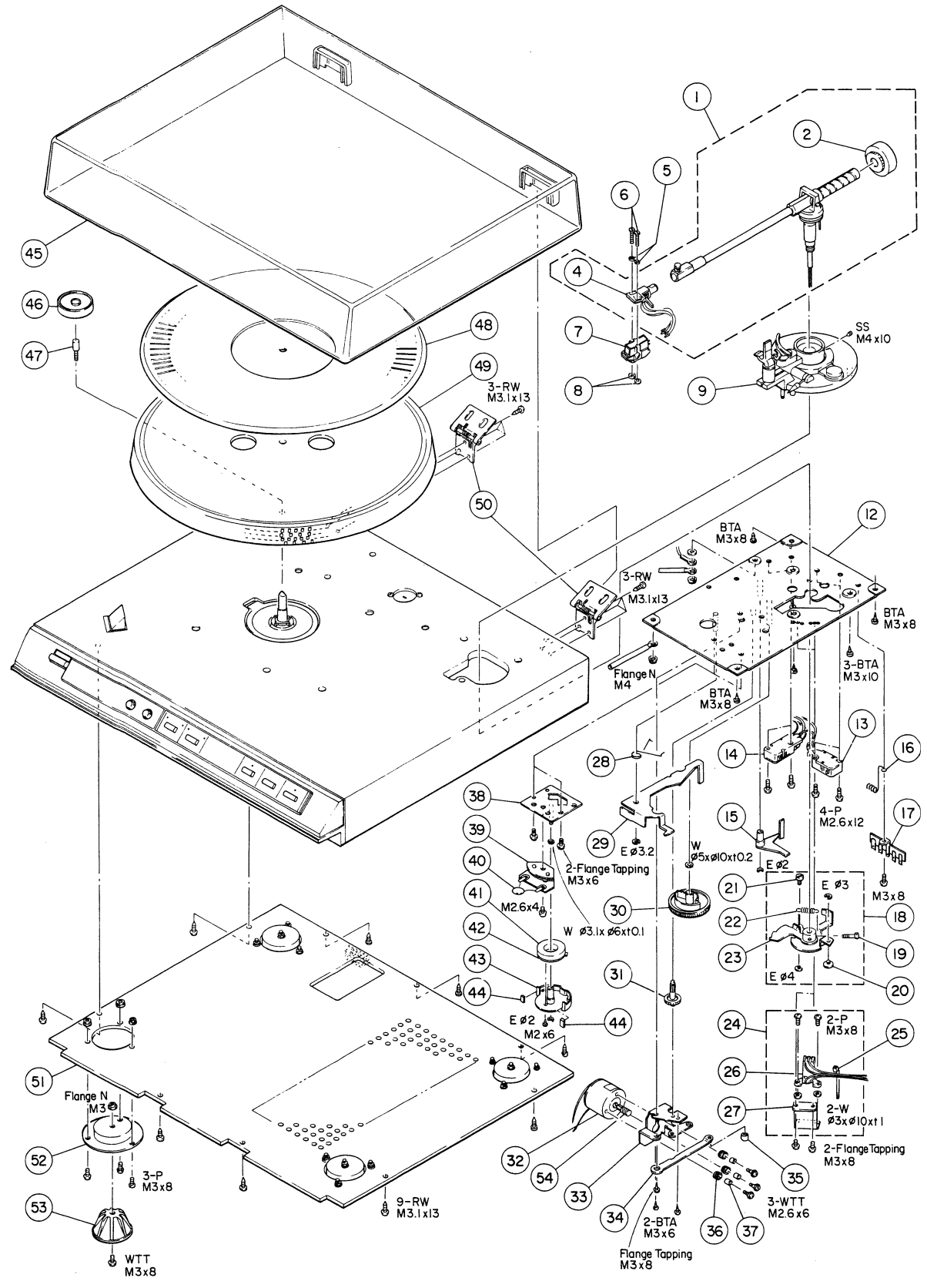

Parts marked with *require longer delivery time.

REF. NO.	PARTS NO.	DESCRIPTION	REMARKS
3 - 1	*5760051300	Pickup Arm Assy [US, UK]	with Cartridge
	*5760051310	Pickup Arm Assy [All except US, UK]	
3 - 2	5760064600	Counterweight	
3 - 3		(not used)	
3 - 4	5760064700	Headshell	
3 - 5	*5760065000	Washer	
3 - 6	*5760064900	Screw	
3 - 7	5760064800	Cartridge	
3 - 8	*5760065100	Nut	
3 - 9	*5760043500	Pickup Base Assy	
3 - 10		(Not used)	
3 - 11		(Not used)	
3 - 12	*5760044800	Sub-chassis Assy, Mechanism	
3 - 13	5760046100	Switch, Micro	
3 - 14	5760046200	Switch, Micro	
3 - 15	*5760046000	Arm, Switch	
3 - 16	*5760043700	Clamper, lead Wire	
3 - 17	*5760055300	Terminal Strip, 5P	
3 - 18	*5760043600	Arm Assy, Feed	
3 - 19	*5781703014	Set Screw, Hexagon	
3 - 20	*5760049500	Eccentric Pin, 2	
3 - 21	*5760049400	Eccentric Pin, 1	
3 - 22	*5760049600	Spring, Arm	
3 - 23	*5760049300	Sub-arm Assy, Feed	
3 - 24	5760050400	Sensor Assy	
3 - 25	*5760055200	Clamper, Cord	
3 - 26	*5760054800	Holder, Sensor	
	*5760054900	LED, GL5PR6	
	*5760055000	Photo Transistor	
3 - 27	*5760055100	Angle, Sensor	
3 - 28	*5760045000	Spring, Select	
3 - 29	*5760044900	Selector Assy	
3 - 30	5760045100	Gear, Main	
3 - 31	5760045200	Gear, 1	
3 - 32	5760045400	Motor Assy, DC	
3 - 33	*5760045500	Bracket, Gear	
3 - 34	*5760045800	Lever Assy, Rotating	
3 - 35	*5760045900	Friction Rubber	
3 - 36	*5760045700	Cushion Rubber	
3 - 37	*5760045600	Tube	
3 - 38	*5760052500	Plate, Sub-chassis	
3 - 39	*5760052900	Solenoid, Size Selector	
3 - 40	*517224800	Capacitor, Mylar 0.1 μ F 50V	
3 - 41	*5760052800	Magnet	
3 - 42	*5760052700	Holder, Magnet	
3 - 43	*5760052600	Cam, Size Selector	
3 - 44	*5760053000	Damper	
3 - 45	*5760044700	Cover, Dust	
3 - 46	*5760057700	Adaptor, EP	
3 - 47	*5760060700	Shaft, Adaptor	
3 - 48	*5760043900	Mat, Rubber [US]	
	*5760044000	Mat, Rubber [All except US]	
3 - 49	*5760059400	Platter, Turntable	
3 - 50	*5760044600	Hinge Assy	
3 - 51	*5760049700	Cover, Bottom	
3 - 52	*5760049800	Holder, Foot	
3 - 53	*5760049900	Foot	
3 - 54	*5760045300	Gear, 2	

[US]: U.S.A. [C]: CANADA [GE]: GENERAL EXPORT [E]: EUROPE [UK]: U.K.
 [A]: AUSTRALIA

EXPLODED VIEW - 4 (P-7)

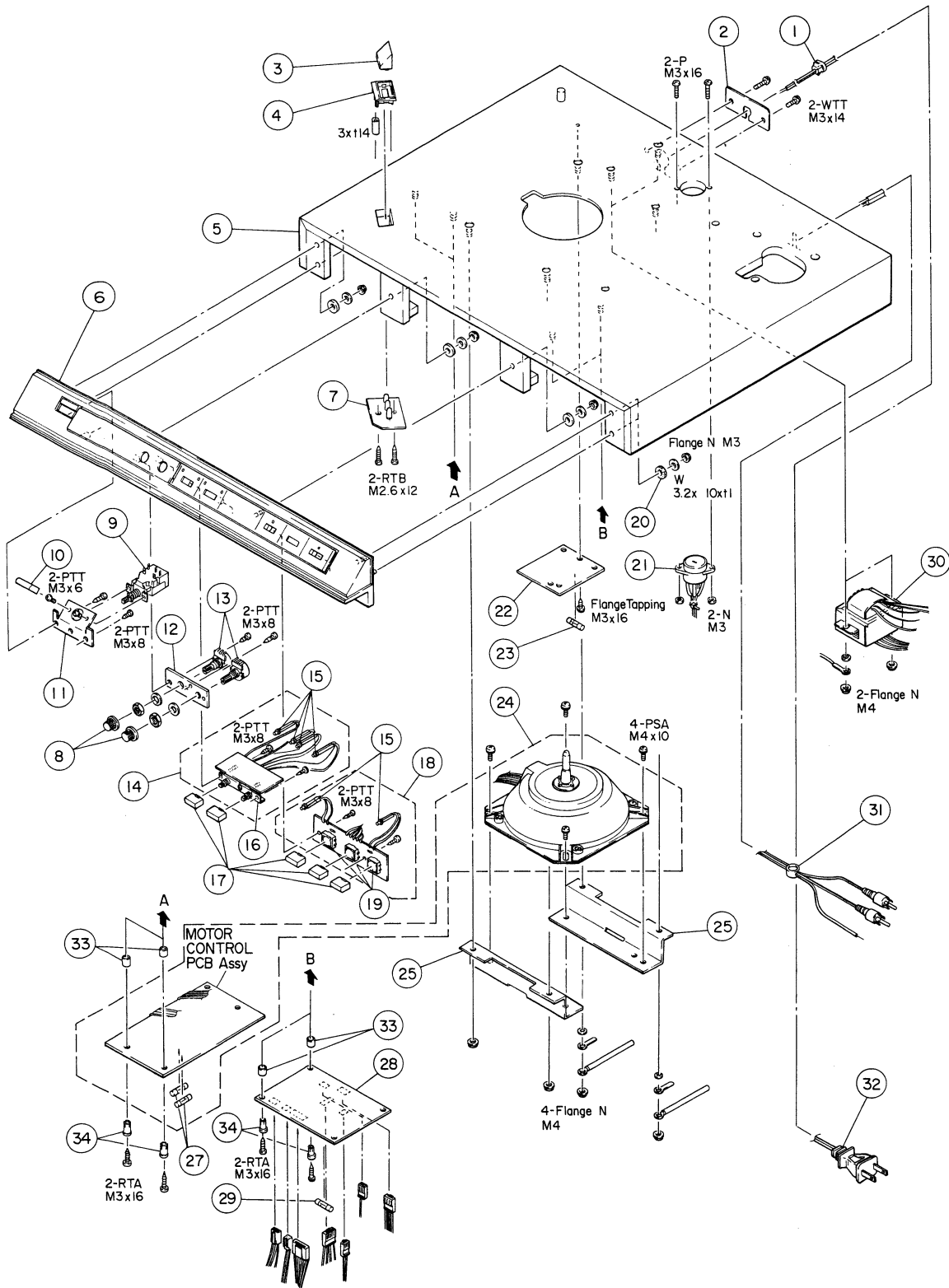

Parts marked with *require longer delivery time.

REF. NO.	PARTS NO.	DESCRIPTION	REMARKS
4 - 1	*5760044300	Strain Relief, A [US, C, GE]	
	*5760044400	Strain Relief, B [E, UK, A]	
4 - 2	*5760044100	Bracket, Strain Relief; A [US, C, GE]	
	*5760044200	Bracket, Strain Relief; B [E, UK, A]	
4 - 3	*5760059500	Prism	
4 - 4	*5760046600	Holder, Prism	
4 - 5	*5760058600	Cabinet, A [All except GE]	
	*5760058700	Cabinet, B [GE]	
4 - 6	*5760059000	Plate Assy, Control	
4 - 7	5760059700	PCB Assy, LED	
4 - 8	5760059300	Knob, VR	
4 - 9	△ 5760054400	Switch, Power [US, C]	
	△ 5760054500	Switch, Power [All except US, C]	
4 - 10	5760043300	Button, Power	
4 - 11	*5760056400	Bracket, Power Switch	
4 - 12	*5760059900	Bracket, VR	
4 - 13	5760059800	Var. Res.,	
4 - 14	*5760059600	PCB Assy, SW	
4 - 15	5760053400	LED	
4 - 16	5760053600	Switch, Push (2-gang)	
4 - 17	5760059200	Button, Push	
4 - 18	*5760050100	PCB Assy, FUNCTION SW	
4 - 19	5760053200	Switch, Tact	
4 - 20	*5760043200	Packing	
4 - 21	△ *5760051200	Voltage Selector	
4 - 22	*5760060900	PCB Assy, POWER [US, C]	incl. 4-23
	*5760060910	PCB Assy, POWER [GE]	incl. 4-23
	*5760060920	PCB Assy, POWER [E, UK, A]	incl. 4-23
4 - 23	△ 5307002700	Fuse, T200mA 250V [GE]	Part of 4-22
	△ 5142177000	Fuse, T50mA 250V [E, UK, A]	Part of 4-22
4 - 24	5760067200	Motor Assy, DD [US, C]	← MOTOR CONTROL PC Board is not supplied individually.
	*5760067210	Motor Assy, DD [All except US, C]	
4 - 25	*5760042900	Angle, Motor	
4 - 26		(not used)	
4 - 27	△ 5041145000	Fuse, 1A [US, C]	
	△ 5307003100	Fuse, T500mA 250V [All except US, C]	
4 - 28	*5760061100	PCB Assy, FULL AUTO CONTROL [US, C]	incl. 4-29
	*5760061110	PCB Assy, FULL AUTO CONTROL [All except US, C]	incl. 4-29
4 - 29	△ 5041145000	Fuse 1A [US, C]	Part of 4-28
	△ 5041138000	Fuse, T500mA [All except US, C]	Part of 4-28
4 - 30	△ *5760060300	Transformer, Power [US, C]	
	△ *5760060400	Transformer, Power [GE]	
	△ *5760060500	Transformer, Power [E]	
	△ *5760060600	Transformer, Power [UK, A]	
4 - 31	5760055400	Cord Assy, Pin	
4 - 32	△ *5760052100	Cord, AC Power [US, C, GE]	
	△ *5760052200	Cord, AC Power [E]	
	△ *5760052300	Cord, AC Power [UK]	
	△ *5760052400	Cord, AC Power [A]	
4 - 33	*5760051400	Collar	
4 - 34	*5760051800	Bushing	

[US]: U.S.A. [C]: CANADA [GE]: GENERAL EXPORT [E]: EUROPE [UK]: U.K.
 [A]: AUSTRALIA

INCLUDED ACCESORIES

REF. NO.	PARTS NO.	DESCRIPTION	REMARKS
	5700013500	P-9/P-7 Owner's Manual	
	5760057600	Card, Overhang Adjustment	
	5760057700	Adaptor, EP	

6 PC BOARDS AND PARTS LIST

PC Boards shown viewed from foil side.

MOTOR CONTROL PCB (P-9)

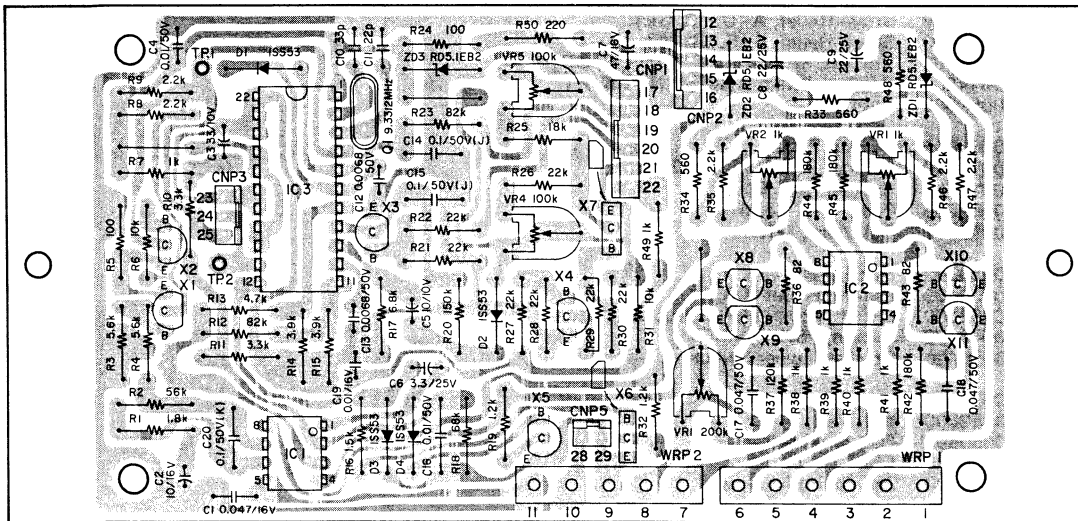

MOTOR CONTROL PCB (P-7)

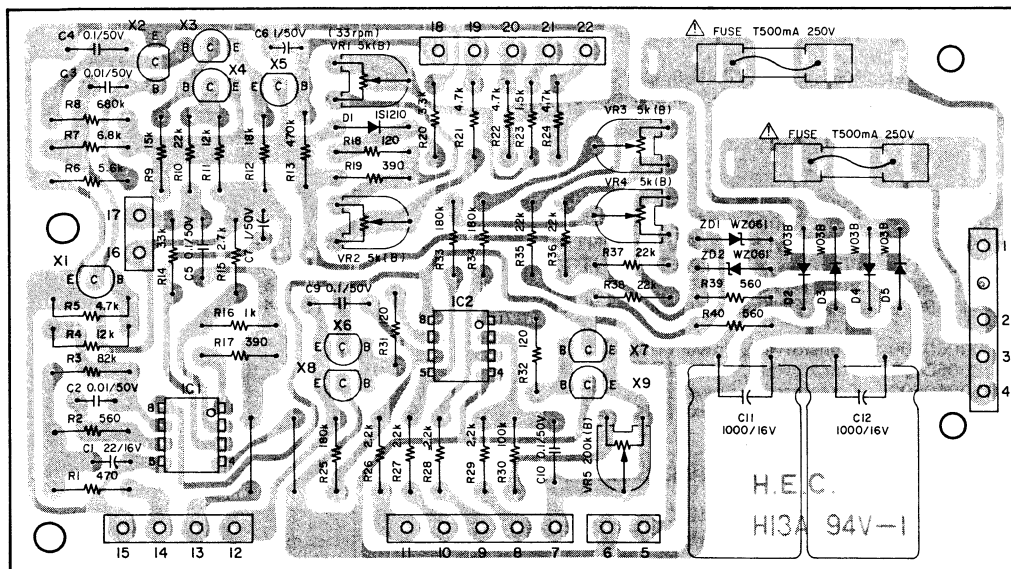

Note: The PC Boards shown above are not supplied individually and parts cannot be individually ordered.

FULL AUTO CONTROL PCB (P-9)

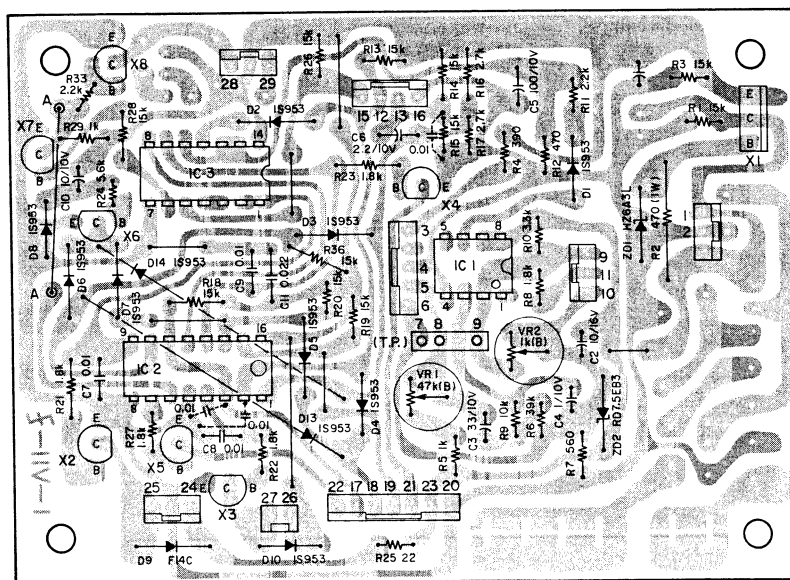

REF. NO.	PARTS NO.	DESCRIPTION
	5760052000	PCB Assy
	5760056500	PCB
IC's		
IC1	5760063500	μPC741C
IC2	5760063600	HD74LS279
IC3	5760063700	HD74LS00
TRANSISTORS		
X1	5042413000	2SC1061
X2~X5	5760062700	2SC2001
X6~X8	5042522000	2SC945
DIODES		
D1~D8	5042536000	1S953
D9	5143087000	W03A
D10	5042536000	1S953
D11, D12		(Not Used)
D13, D14	5042536000	1S953
ZD1	5143144000	HZ6A3L
ZD2	5143122000	RD7.5EB3
RESISTORS		
All resistors are rated ±5% tolerance, ¼ watt and are carbon type unless otherwise noted.		
R1	5183110000	15kΩ
R2	5054804000	470Ω 1W
R3	5183110000	15kΩ
R4	5183072000	390Ω
R5	5183082000	1kΩ
R6	5183120000	39kΩ
R7	5183076000	560Ω
R8	5183088000	1.8kΩ
R9	5183106000	10kΩ
R10	5183094000	3.3kΩ
R11	5183090000	2.2kΩ
R12	5183074000	470Ω
R13~R15	5183110000	15kΩ
R16, R17	5183092000	2.7kΩ
R18~R20	5183110000	15kΩ

REF. NO.	PARTS NO.	DESCRIPTION
R21~R23	5183088000	1.8kΩ
R24	5183100000	5.6kΩ
R25	5183042000	22Ω
R26	5183110000	15kΩ
R27	5183088000	1.8kΩ
R28	5183110000	15kΩ
R29	5183082000	1kΩ
R30	5183100000	5.6kΩ
R31		(Not Used)
R32		(Not Used)
R33	5183090000	2.2kΩ
R34		(Not Used)
R35		(Not Used)
R36	5183110000	15kΩ
CAPACITORS		
C1	5173036000	Elec. 47μF 16V
C2	5173010000	Elec. 10μF 16V
C3	5173027000	Elec. 33μF 16V
C4	5172992000	Elec. 1μF 10V
C5	5173044000	Elec. 100μF 10V
C6	5172996000	Elec. 2.2μF 10V
C7~C9	5172236000	Ceramic 0.01μF 25V
C10	5173010000	Elec. 10μF 10V
C11	5172240000	Ceramic 0.022μF 10V
VARIABLE RESISTORS		
VR1	5280062101	47kΩ(B), SR-19R
VR2	5280061101	1kΩ(B), SR-19R

POWER PCB (P-9)

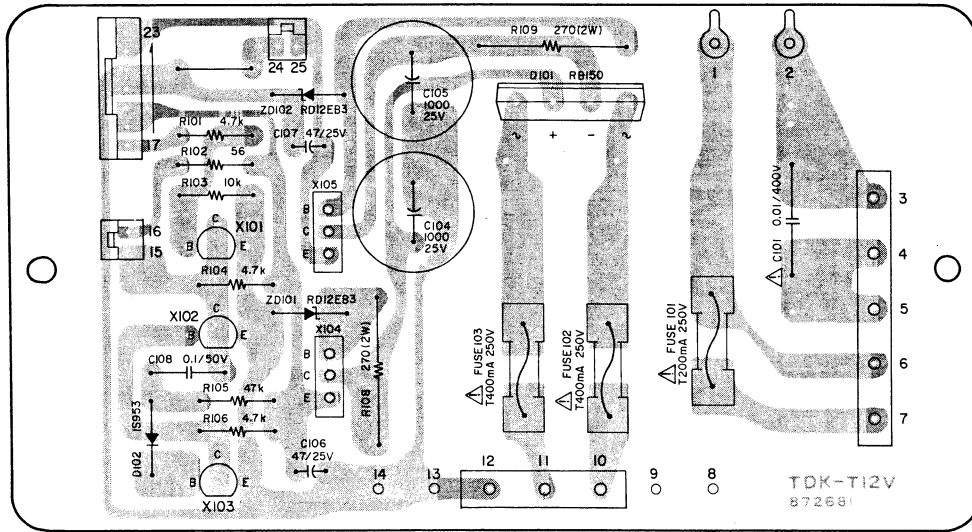

REF. NO.	PARTS NO.	DESCRIPTION
	5760051500	PCB Assy [US, C]
	5760051510	PCB Assy [All except US, C]
	5760056100	PCB
TRANSISTORS		
X101~X103	5042522000	2SC945
X104	5760062500	2SC1449
X105	5760062600	2SB644
DIODES		
D101	5760062800	RB150
D102	5042536000	1S953
ZD101	5760062900	RD12EB3
ZD102	5760062900	RD12EB3
CARBON RESISTORS		
All resistors are rated $\pm 5\%$ tolerance $\frac{1}{4}$ watt.		
R101	5183098000	4.7k Ω
R102	5183052000	56 Ω
R103	5183106000	10k Ω
R104	5183098000	4.7k Ω
R105	5183122000	47k Ω
R106	5183098000	4.7k Ω
R107		(Not Used)
R108, R109	5183068000	270 Ω 2W
CAPACITORS		
C101	Δ 5052917000	Spark Killer 0.01 μ F 450V
C102		(Not Used)
C103		(Not Used)
C104, C105	5173082000	Elec. 1000 μ F 25V
C106, C107	5173037000	Elec. 47 μ F 25V
C108	5170449000	Mylar 0.1 μ F 50V

REF. NO.	PARTS NO.	DESCRIPTION
MISCELLANEOUS		
FUSE101	Δ 5142128000	Fuse T200mA [All except US, C]
FUSE102	Δ 5142132000	Fuse T400mA [All except US, C]
	Δ 5041145000	Fuse 1A [US, C]
FUSE103	Δ 5142132000	Fuse T400mA [All except US, C]
	Δ 5041145000	Fuse 1A [US, C]
	5760056200	Fuse Holder, A [US, C]
	5760056300	Fuse Holder, B [All except US, C]
	5760055600	Connector Plug, 2P
	5760056000	Connector Plug, 7P

[US]: U.S.A. [C]: CANADA [GE]: GENERAL EXPORT [E]: EUROPE [UK]: U.K.
[A]: AUSTRALIA

SW PCB (P-9)

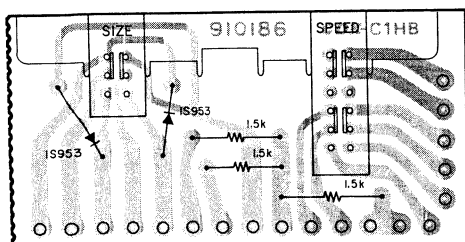

LED PCB (P-9)

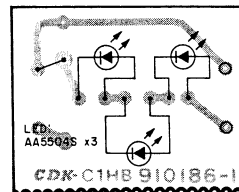

FUNCTION SW PCB (P-9)

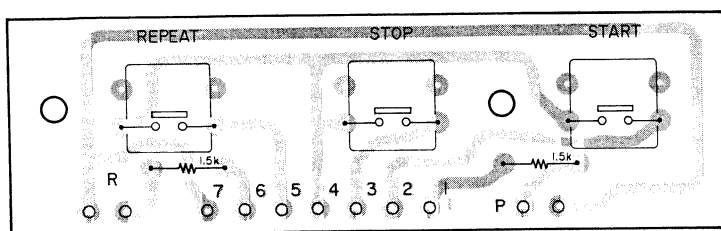

SW PCB (P-9)

REF. NO.	PARTS NO.	DESCRIPTION
	5760050200	PCB Assy
	57600533500	PCB
	5760053600	Switch, Push
	5042413000	Diode, 1S953
	5183296000	Carbon Resistor, 1.5kΩ ¼W
	5760053400	LED
	5760053900	Connector Assy, E
	5760054000	Connector Assy, F
	5760054100	Connector Assy, G
	5760054200	Connector Assy, H

LED PCB (P-9)

REF. NO.	PARTS NO.	DESCRIPTION
	5760050300	PCB Assy
	5760054600	PCB
	5760054700	LED, AA5504S
	5760058400	Connector Assy

FUNCTION SW PCB (P-9)

REF. NO.	PARTS NO.	DESCRIPTION
	5760050100	PCB Assy
	5760053100	PCB
	5760053200	Switch, Tact
	5183296000	Carbon Resistor, 1.5kΩ ¼W
	5760053800	Connector Assy, D
	5760053400	LED, PR-2434

FULL AUTO CONTROL PCB (P-7)

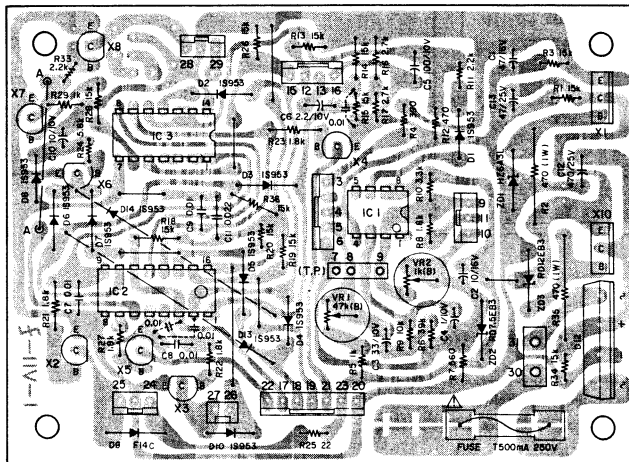

REF. NO.	PARTS NO.	DESCRIPTION
	5760061100	PCB Assy [US, C]
	5760061110	PCB Assy [All except US, C]
	5760056500	PCB
IC's		
IC1	5760063500	μPC741C
IC2	5760063600	HD74LS279
IC3	5760063700	HD74LS00
TRANSISTORS		
X1	5042413000	2SC1061
X2~X5	5760062700	2SC2001
X6~X8	5042522000	2SC945
X9		(Not Used)
X10	5042413000	2SC1061
DIODES		
D1~D8	5042536000	1S953 or 1SS53
D9	5143087000	F14C
D10	5042536000	1S953 or 1SS53
D11		(Not Used)
D12	5760062800	RP150 or RP151
D13, D14	5042536000	1S953 or 1SS53
ZD1	5143144000	Zener, HZ6A3L
ZD2	5143122000	Zener, RD7.5EB3
ZD3	5760062900	Zener, RD12EB3
RESISTORS		
All resistors are rated ±5% tolerance, ¼ watt and are carbon type unless otherwise noted.		
R1	5240171000	15kΩ
R2	5052708000	470Ω 1W Metal Oxide
R3	5240171000	15Ω
R4	5240171000	15kΩ
R5	5240168200	1kΩ
R6	5240172000	3.9kΩ
R7	5240167600	560Ω
R8	5240168800	1.8kΩ
R9	5240170600	10kΩ
R10	5240169400	3.3kΩ
R11	5240169000	2.2kΩ
R12	5240167400	470Ω
R13~R15	5240171000	15kΩ
R16, R17	5240169200	2.7kΩ
R18	5240170000	5.6kΩ

REF. NO.	PARTS NO.	DESCRIPTION
R19, R20	5240171000	15kΩ
R21~R23	5240168800	1.8kΩ
R24	5240170000	5.6kΩ
R25	5240164200	22Ω
R26	5240171000	15kΩ
R27	5240168800	1.8kΩ
R28	5240171000	15kΩ
R29	5240168200	1kΩ
R30	5240170000	5.6kΩ
R31		(Not Used)
R32		(Not Used)
R33	5240169000	2.2kΩ
R34	5240171000	15kΩ
R35	5052708000	470Ω 1W Metal Oxide
R36	5240171000	15kΩ
CAPACITORS		
C1	5173036000	Elec. 47μF 16V
C2	5173010800	Elec. 10μF 16V
C3	5173026000	Elec. 33μF 10V
C4	5172992000	Elec. 1μF 10V
C5	5173010000	Elec. 100μF 10V
C6	5172996000	Elec. 2.2μF 10V
C7~C9	5172236000	Ceramic 0.01μF 50V
C10	5173010000	Elec. 10μF 10V
C11	5172240000	Ceramic 0.022μF 50V
C12	5173037000	Elec. 470μF 25V
C13	5173037000	Elec. 47μF 25V
	5172236000	Ceramic 0.01μF
VARIABLE RESISTORS		
VR1	5280062100	47kΩ (B)
VR2	5280061100	1kΩ (B)
MISCELLANEOUS		
Δ 5307003100	Fuse, T500mA ; 250V	
	[All except US, C]	
Δ 5041145000	Fuse, 1A [US, C]	
5041145000	Fuse, Holder, B [All except US, C]	
5760056200	Fuse Holder, A [US, C]	
5760055700	Connector Plug, 3P	
5760058300	Connector Plug, 4P	
5760056000	Connector Plug, 7P	
5760055800	Connector Plug, 5P	
5760067500	Connector Plug, 3P	
5760067400	Connector Plug, 2P	

[US]: U.S.A. [C]: CANADA [GE]: GENERAL EXPORT [E]: EUROPE [UK]: U.K.
[A]: AUSTRALIA

POWER PCB (P-7)

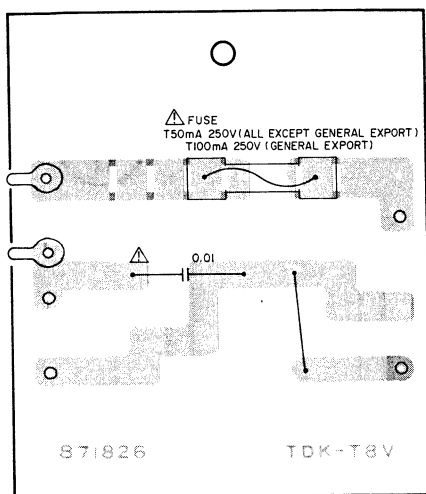

SW PCB (P-7)

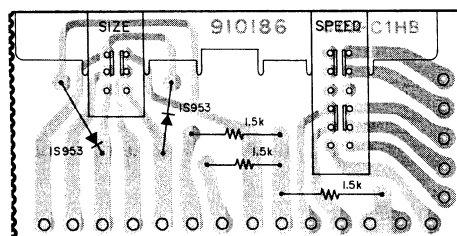

LED PCB (P-7)

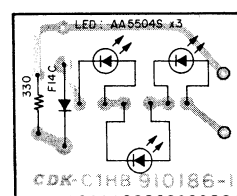

FUNCTION SW PCB (P-7)

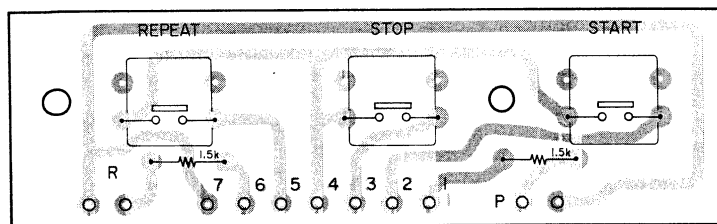

POWER PCB (P-7)

REF. NO.	PARTS NO.	DESCRIPTION
	5760060900	PCB Assy [US, C]
	5760060910	PCB Assy [GE]
	5760060920	PCB Assy [All except US, C, GE]
	5760064400	PCB
△	5052917000	Spark Killer , 0.01μF 450V
△	5307002700	Fuse, T200mA ; 250V [GE]
△	5142177000	Fuse, T50mA ; 250V [E, UK, A]
	5760056200	Fuse Holder, A
	5760056300	Fuse Holder, B

SW PCB (P-7)

REF. NO.	PARTS NO.	DESCRIPTION
	5760059600	PCB Assy
	5760061200	PCB
	5760053600	Switch, Push
	5042413000	Diode, 1S953
	5183296000	Carbon Resistor, 1.5kΩ ¼W
	5760053400	LED
	5760053900	Connector Assy (E)
	5760061400	Connector Assy (K)

FUNCTION SW PCB (P-7)

REF. NO.	PARTS NO.	DESCRIPTION
	5760050100	PCB Assy
	5760053100	PCB
	5760053200	Switch, Tact
	5183296000	Carbon Resistor, 1.5kΩ ¼W
	5760053800	Connector Assy, D
	5760053400	LED, PR-2434

LED PCB (P-7)

REF. NO.	PARTS NO.	DESCRIPTION
	5760059700	PCB Assy
	5760054600	PCB
	5760054700	LED
	5240167200	Carbon Resistor, 390Ω ¼W
	5143087000	W03A

[US]: U.S.A. [C]: CANADA [GE]: GENERAL EXPORT [E]: EUROPE [UK]: U.K.
[A]: AUSTRALIA

ASSEMBLING HARDWARE CODING LIST

All screws conform to ISO standards, and have crossrecessed heads, unless otherwise noted. ISO screws have the head inscribed with a point as in the figure to the right.

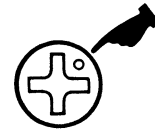

FOR EXAMPLE:

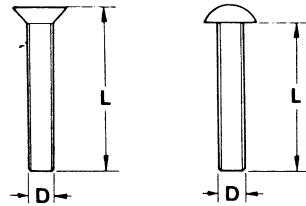
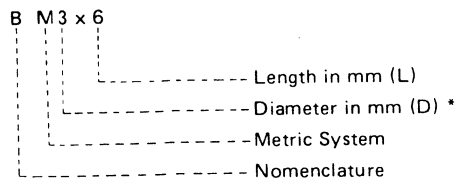

* Inner dia. for washers and nuts

	Code	Name	Type		Code	Name	Type	
MACHINE SCREW	R	Round Head Screw		TAPPING SCREW	BTA	Binding Head Tapping Screw(A Type)		
	P	Pan Head Screw			BTB	Binding Head Tapping Screw(B Type)		
	T	Stove Head Screw (Truss)			RTA	Round Head Tapping Screw(A Type)		
	B	Binding Head Screw			RTB	Round Head Tapping Screw(B Type)		
	F	Flat Countersunk Head Screw			SETSCREW	SF	Hex Socket Setscrew(Flat Point)	
	O	Oval Countersunk Head Screw				SC	Hex Socket Setscrew(Cup Point)	
WOOD SCREW	RW	Round Head Wood Screw	SS	Slotted Socket Setscrew(Flat Point)				
TAPTITE SCREW	PTT	Pan Head Taptite Screw		WASHER	E	E-Ring (Retaining Washer)		
	WTT	Washer Head Taptite Screw			W	Flat Washer (Plain)		
SEMS SCREW	BSA	Binding Head SEMS Screw(A Type)			SW	Lock Washer (Spring)		
	BSB	Binding Head SEMS Screw(B Type)			LWI	Lock Washer (Internal Teeth)		
	BSF	Binding Head SEMS Screw(F Type)			LWE	Lock Washer (External Teeth)		
	PSA	Pan Head SEMS Screw(A Type)		TW	Trim Washer (Countersunk)			
	PSB	Pan Head SEMS Screw(B Type)		NUT	N	Hex Nut		

FULL AUTO CONTROL PCB

- IC1 μ PC741C or μ PC151C
- IC2 HD74LS279
- IC3 HD74LS00
- X1 2SC1061
- X2 ~ X5 2SC2001
- X6 ~ X8 2SC945 or 2SC2308 or 2SC1815
- D1 ~ D8 IS953 or IS553
- D9 FI4C or W03A or EM1
- D10 IS953 or IS553
- D11 (Not used)
- D12, D14 IS953 or IS553
- ZD1 MZ6A3L
- ZD2 RD7.5EB3

MOTOR CONTROL PCB

- IC1, IC2 μ PC4558C or NJM4558D or RC1558P
- IC3 SM-6415A-4S
- X1 ~ X5 2SC945P,Q,K or 2SC2308B,C,D
- X6, X7 2SA733P,Q or 2SA844C,D
- X8 2SD667B,C
- X9 2SB647B,C
- X10 2SD667B,C
- X11 2SB647B,C
- D1 ~ D4 IS553
- ZD1 ~ ZD3 RDS1EB2 or W2050

POWER PCB

- X101 ~ X103 2SC945 or 2SC2308 or 2SC1815
- X104 2SC1449
- X105 2SB744
- D101 RB150 or RB151
- D102 IS953 or IS553
- ZD101, ZD102 RD12EB3

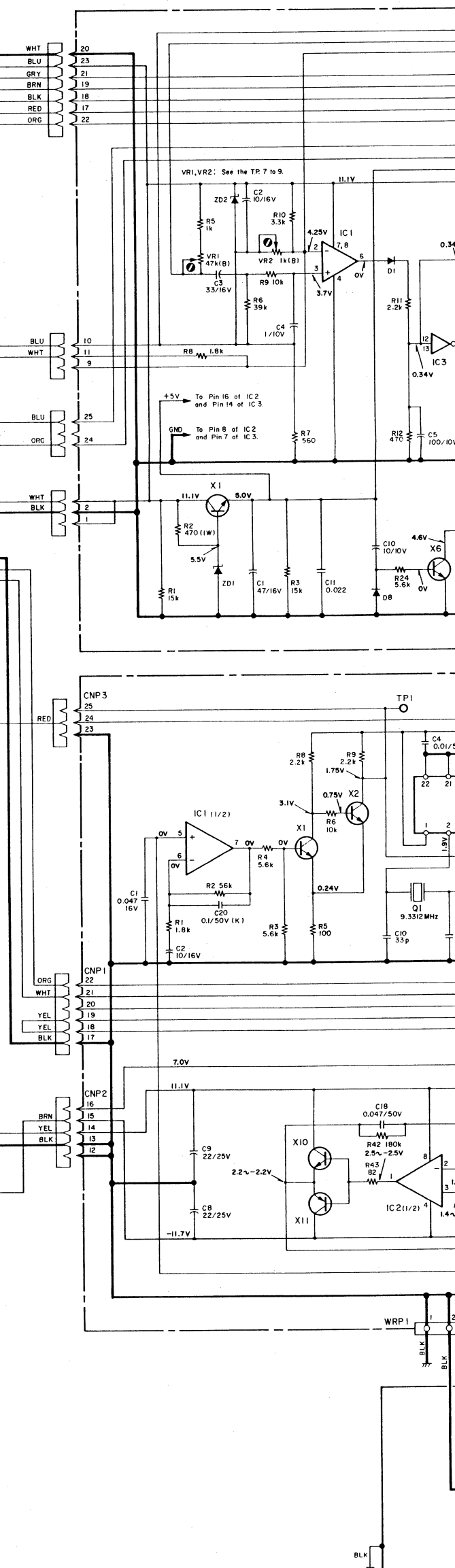
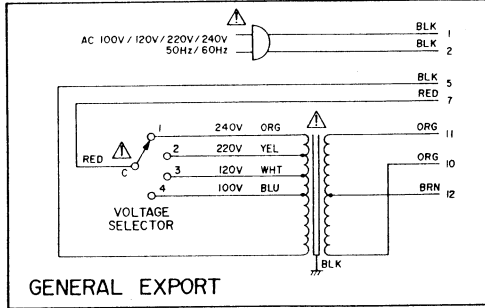
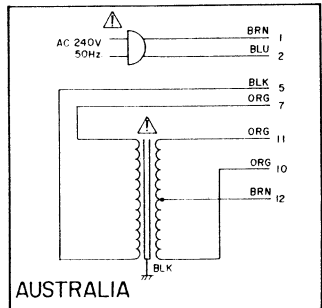
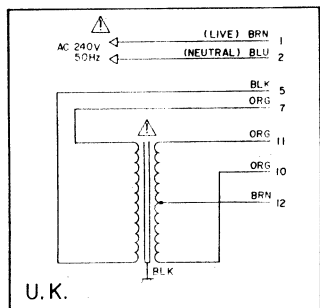
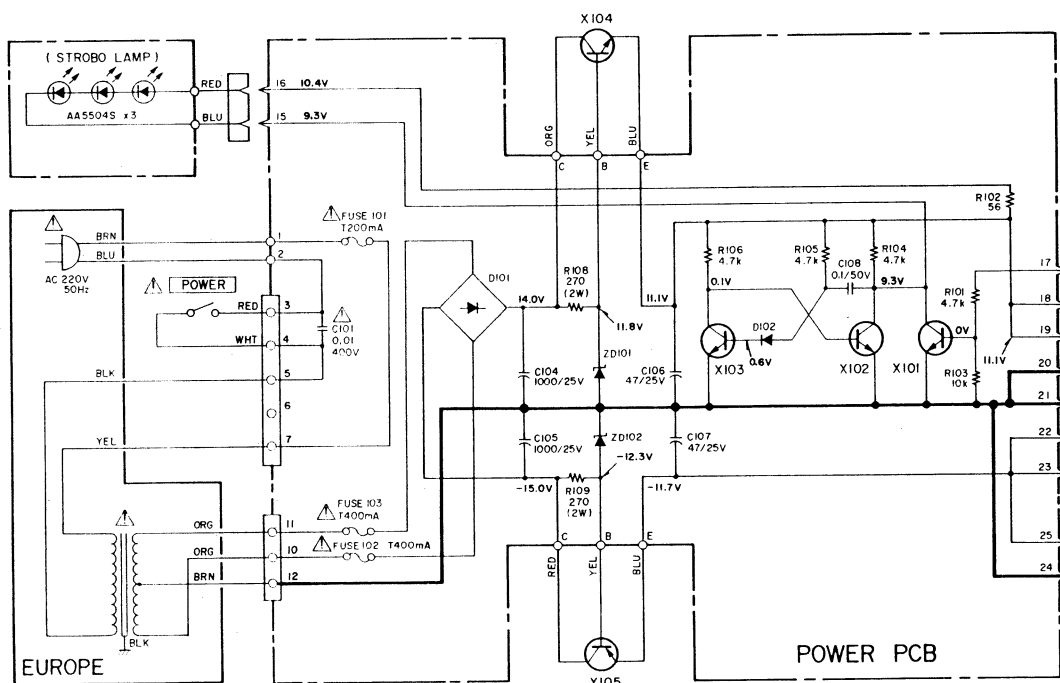
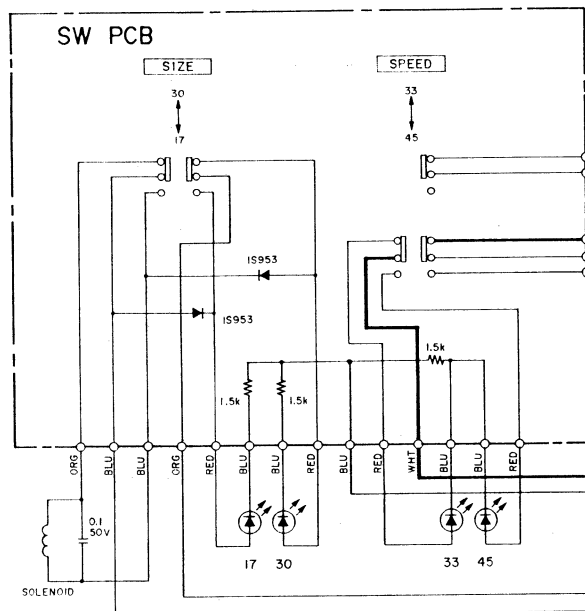
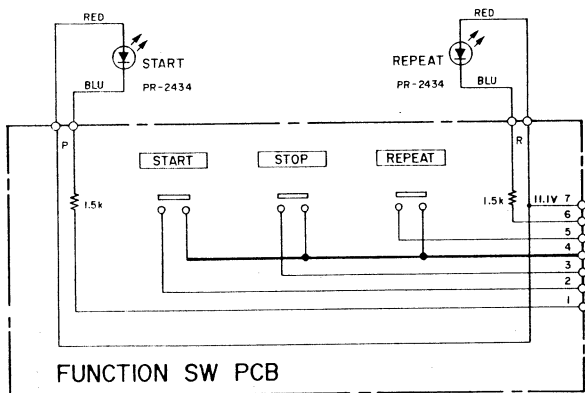

NOTES

1. All resistors are 1/4W, $\pm 5\%$, unless otherwise noted. Resistor values are in ohms (k = kilo-ohms, M = meg-ohms).
2. All capacitor values are in microfarads.
3. The voltages given in each portion are reference values measured with a tester (input impedance : 10M ohms) with a speed setting of 33-1/3 r.p.m. Measurements were made while tracking a disc.

4. Δ Parts marked with this sign are safety critical components. They must always be replaced with identical components - refer to the appropriate parts list and ensure exact replacement.
5. — : +B power supply circuit
6. — : -B power supply circuit

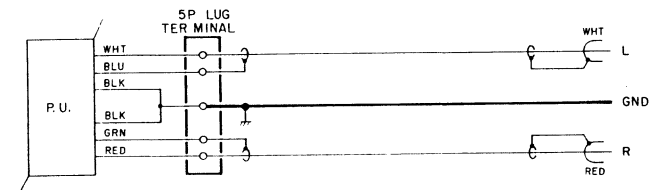
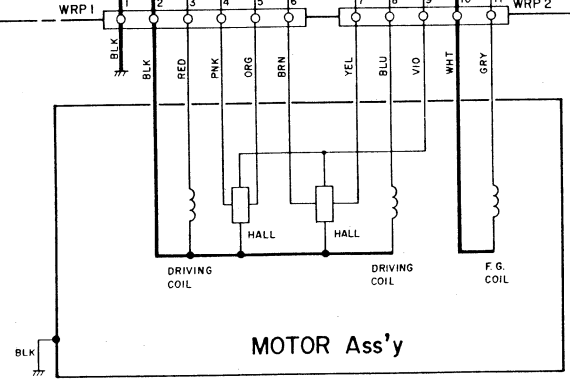
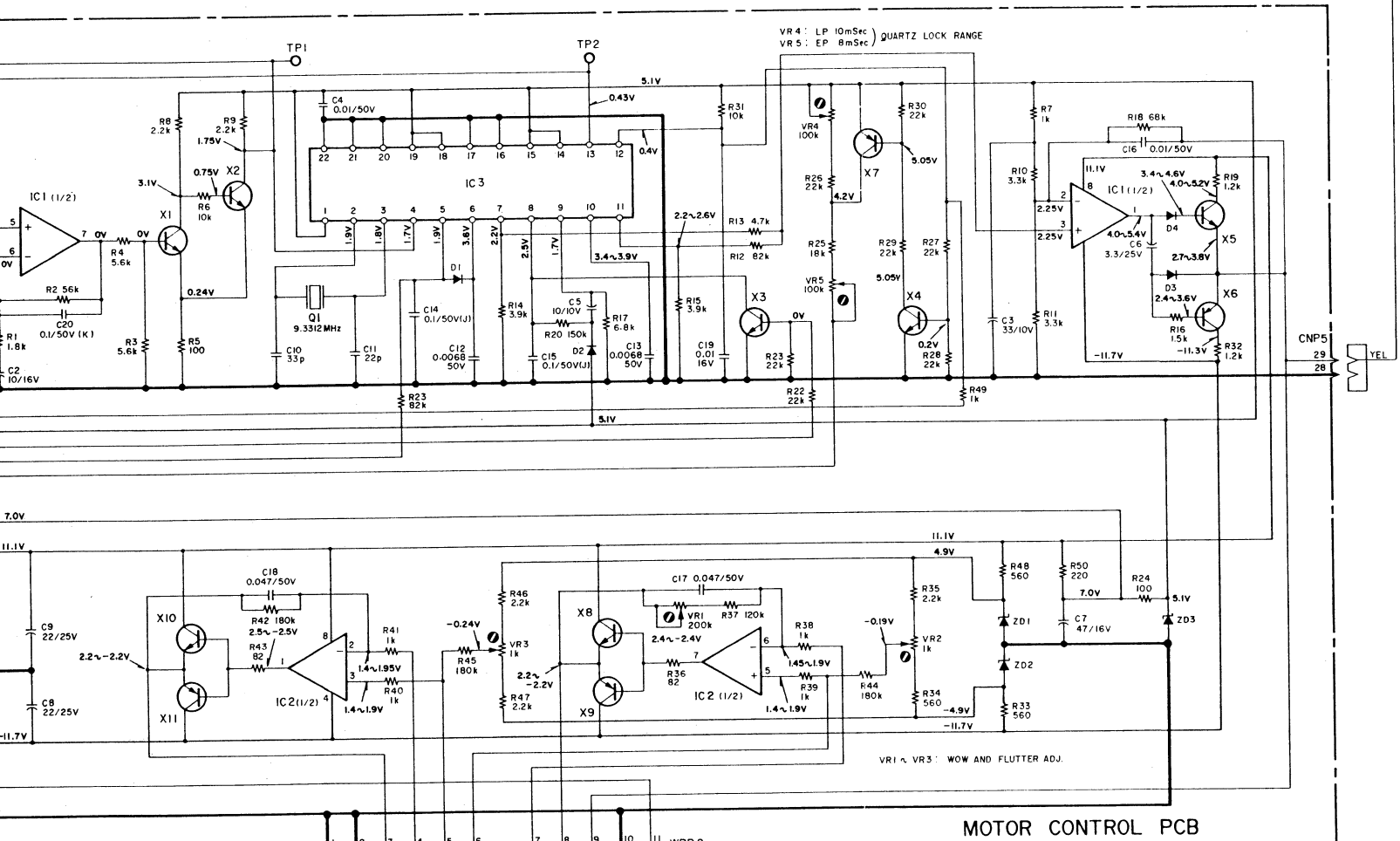
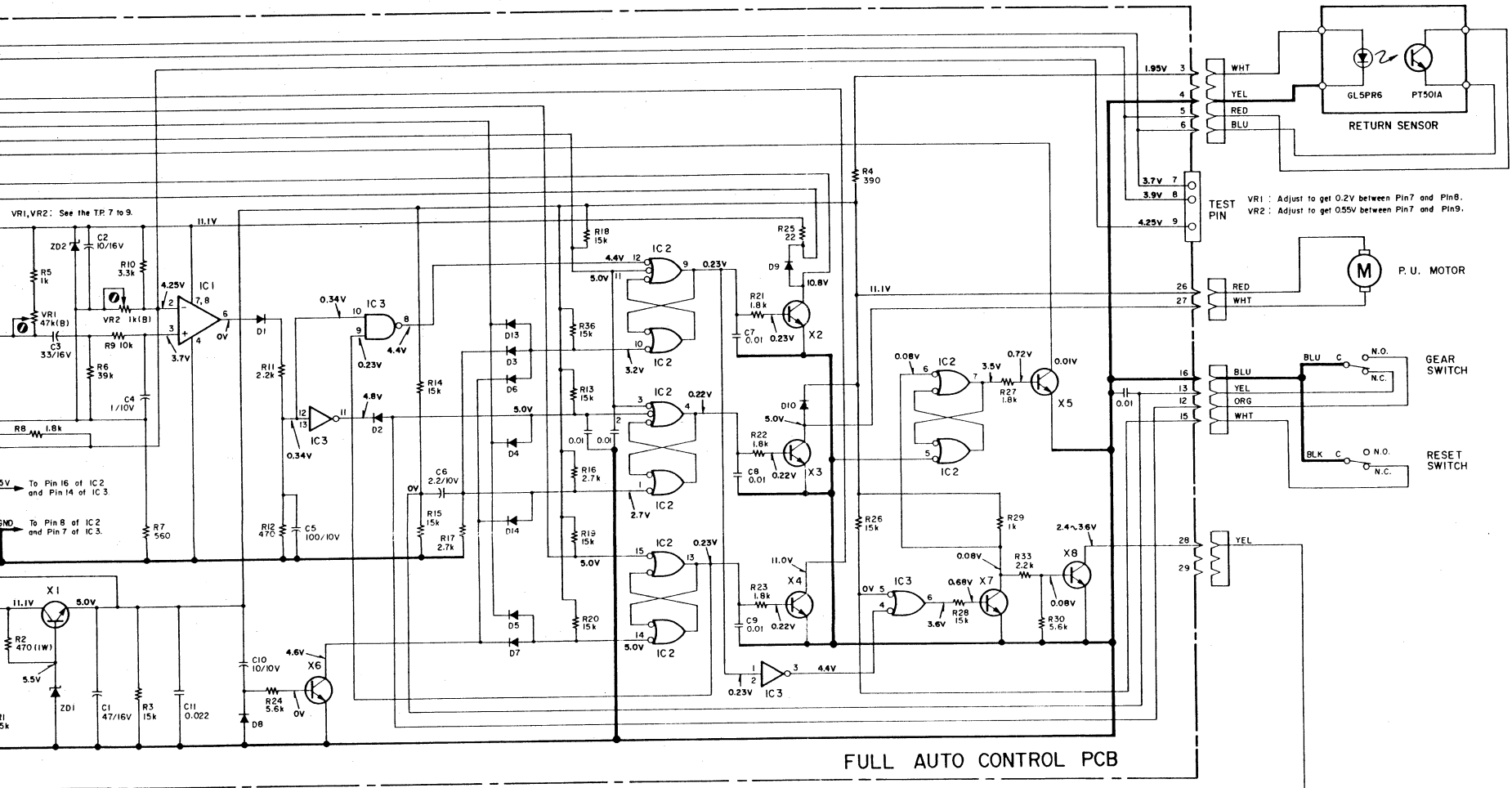

ical components.
al components -
re exact replace-

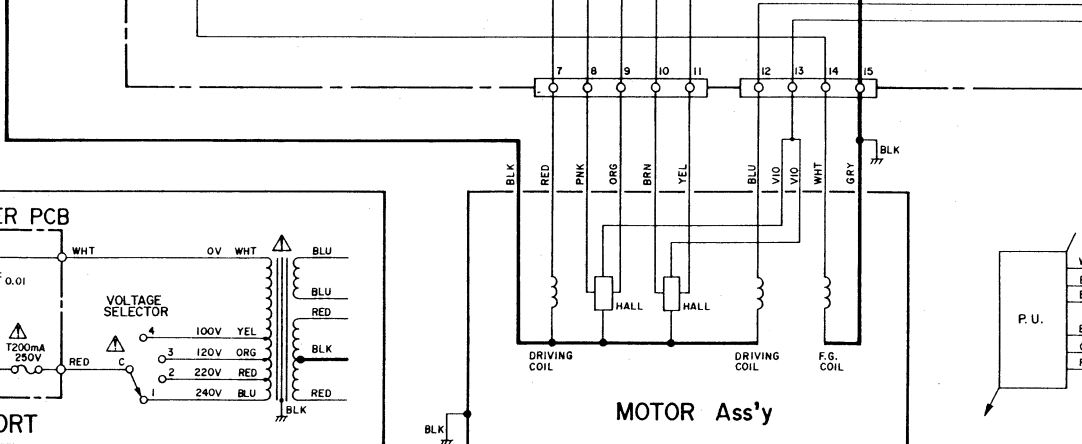
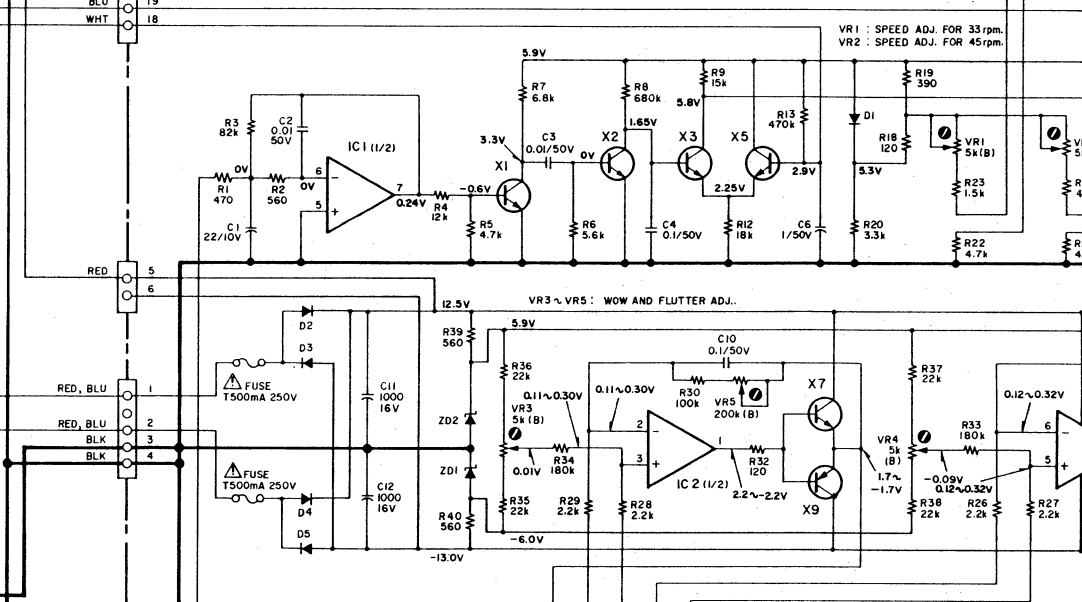
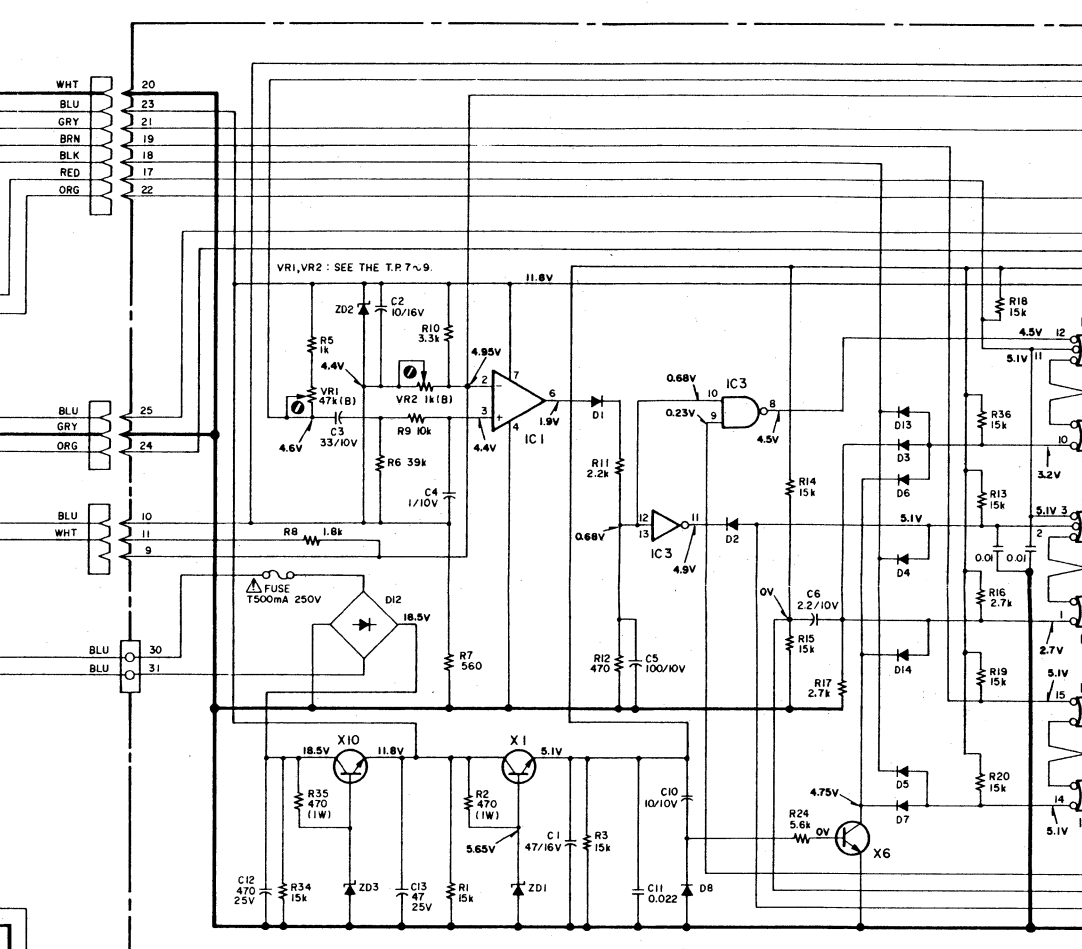
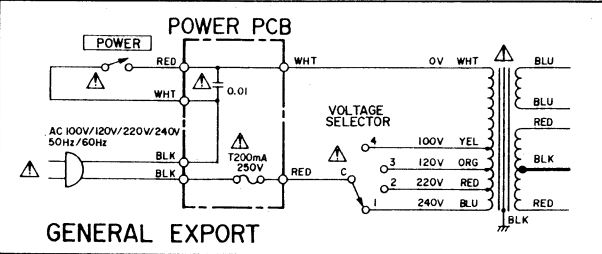
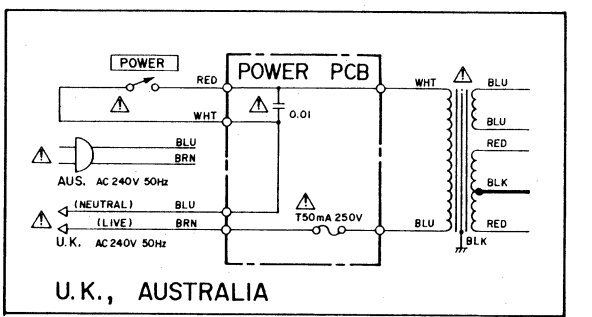
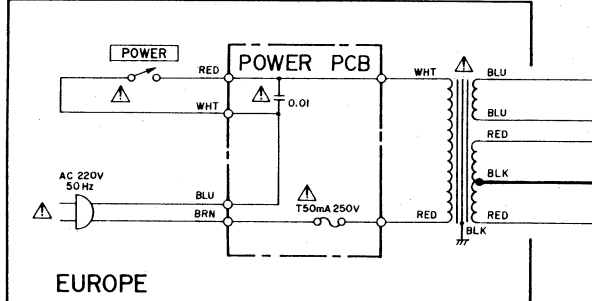
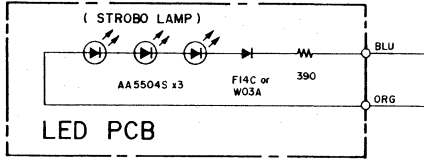
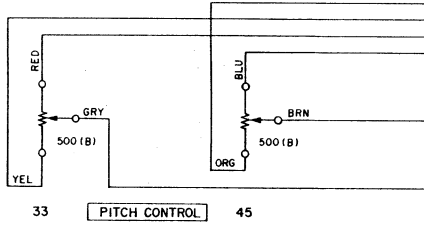
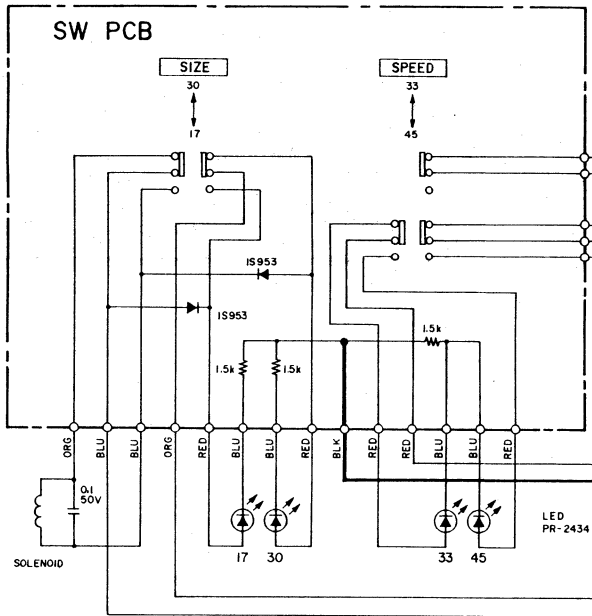
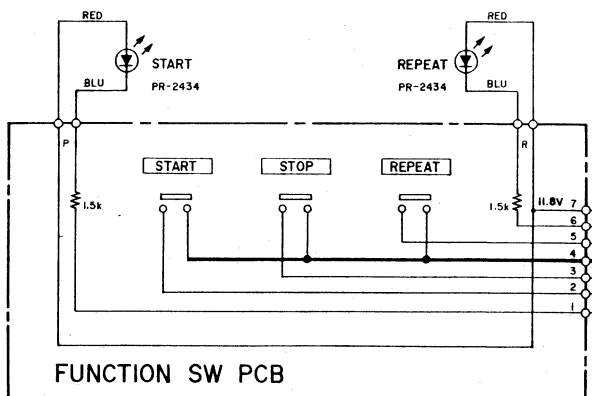

NOTES

1. All resistors are 1/4W, ±5%, unless otherwise noted. Resistor values are in ohms (k = kilo-ohms, M = meg-ohms).
2. All capacitor values are in microfarads.
3. The voltages given in each portion are reference values measured with a tester (input impedance : 10M ohms) with a speed setting of 33-1/3 r.p.m. Measurements were made while tracking a disc.

4. Δ Parts marked with this sign are safety critical components. They must always be replaced with identical components - refer to the appropriate parts list and ensure exact replacement.
5. — : +B power supply circuit
6. — : -B power supply circuit

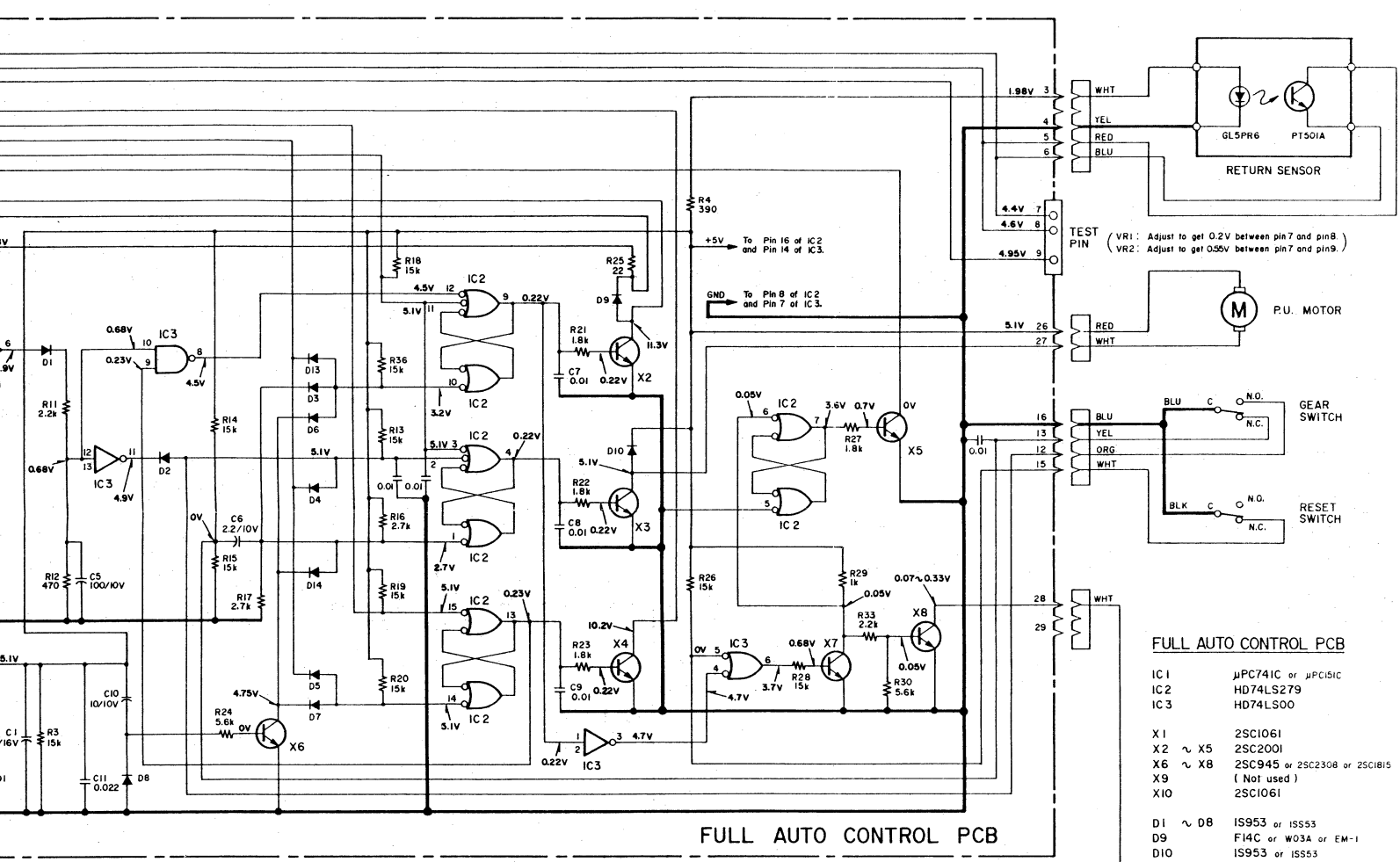

- FULL AUTO CONTROL PCB**
- IC 1 μ PCT41C or μ PC151C
 - IC 2 HD74LS279
 - IC 3 HD74LS00
 - X 1 25C1061
 - X 2 ~ X 5 2SC2001
 - X 6 ~ X 8 2SC945 or 2SC2308 or 2SC1815
 - X 9 (Not used)
 - X 10 2SC1061
 - D 1 ~ D 8 IS953 or IS553
 - D 9 F14C or W03A or EM-1
 - D 10 IS953 or IS553
 - D 11 (Not used)
 - D 12 RP150 or RP151
 - D 13 , D 14 IS953 or IS553
 - ZD 1 HZ6A3L
 - ZD 2 RD7.5EB3
 - ZD 3 RD12EB3 or HZ12LA2

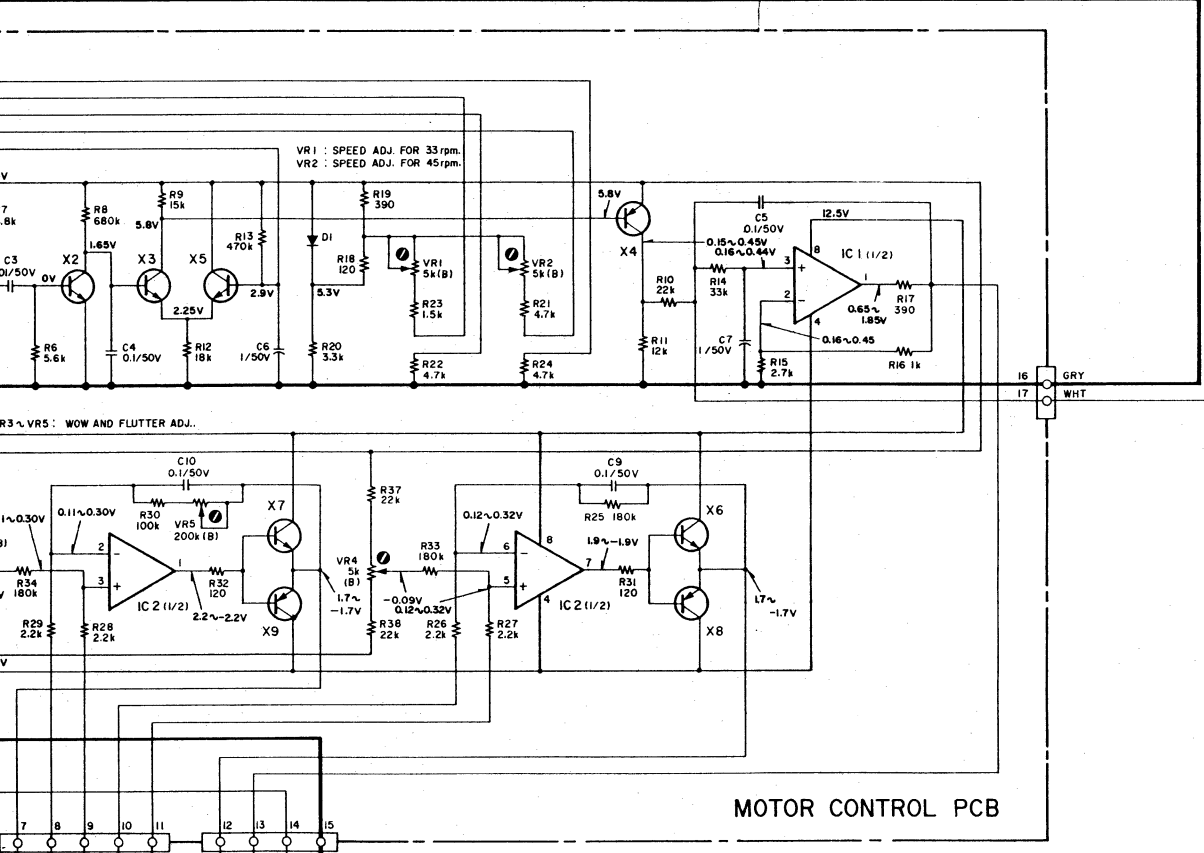

- MOTOR CONTROL PCB**
- IC 1 , IC 2 NJM4558D or μ PC4558C or μ PC1458C or RC4558P
 - X 1 ~ X 3 2SC945K,L or 2SC2308B,C
 - X 4 2SA733P,Q or 2SA844B,C,D or 2SA641F,M
 - X 5 2SC945K,L or 2SC2308B,C
 - X 6 , X 7 2SD468B,C
 - X 8 , X 9 2SB562B,C
 - D 1 IS1210
 - D 2 ~ D 5 W03B or W03C or F14C
 - ZD 1 , ZD 2 WZ061

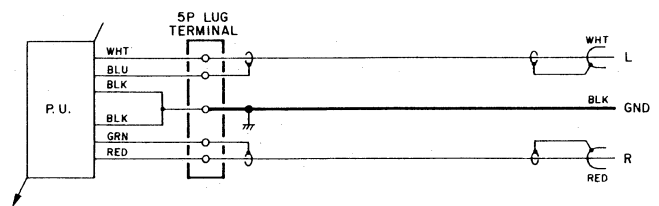
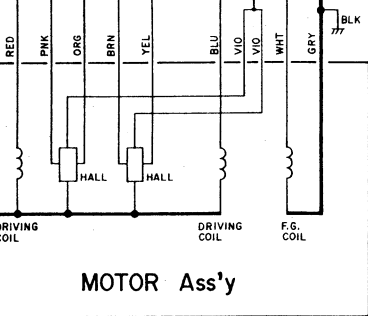

safety critical components.
with identical components -
t and ensure exact replace-