

# SCHEMATIC DIAGRAMS

回路図

## CONTENTS 目次

MAIN PCB (1/2), TR1 PCB, TR2 PCB, TR3 PCB .....	Page 1/7
MAIN (2/2) PCB .....	Page 2/7
ANALOG SW PCB .....	Page 3/7
EQ-BIAS PCB .....	Page 4/7
FRONT PCB, CONTROL PCB, KEY 1 PCB, KEY 2 PCB .....	Page 5/7
PHONE PCB .....	Page 6/7
TRANS 1 PCB, TRANS 2 PCB, POWER SW PCB, SW PCB .....	Page 7/7

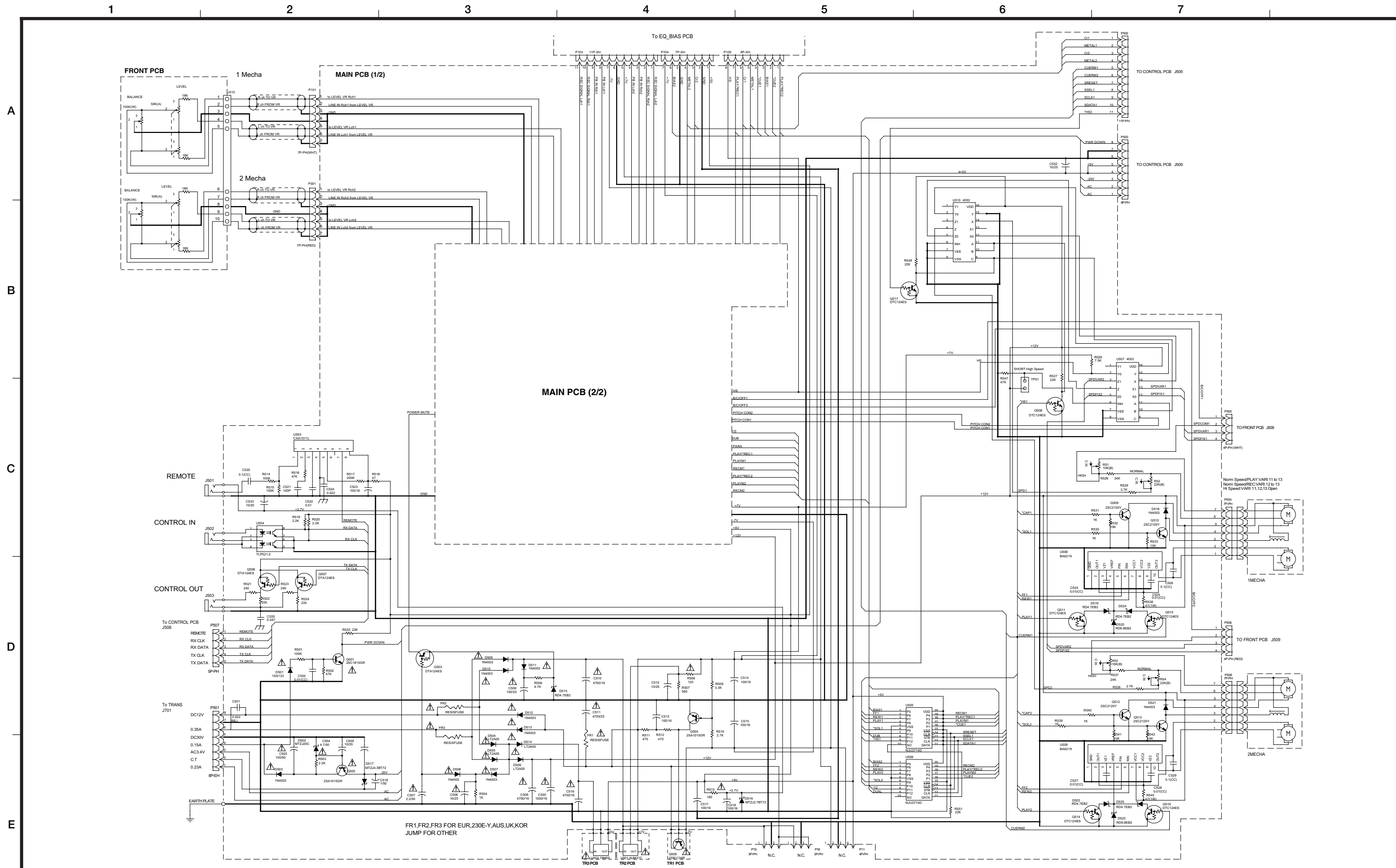

**Double Auto Reverse Cassette Deck 302MKII**

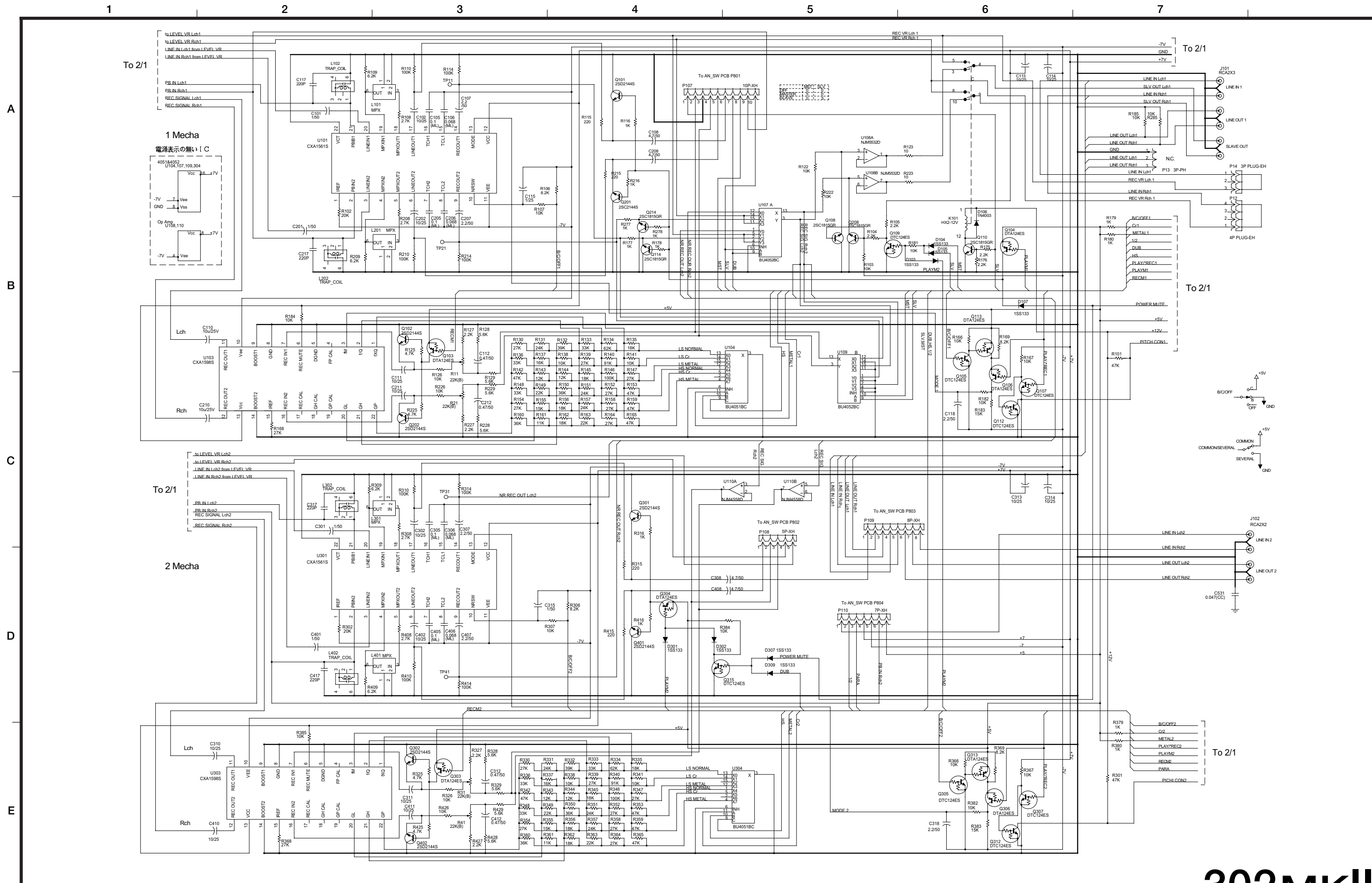

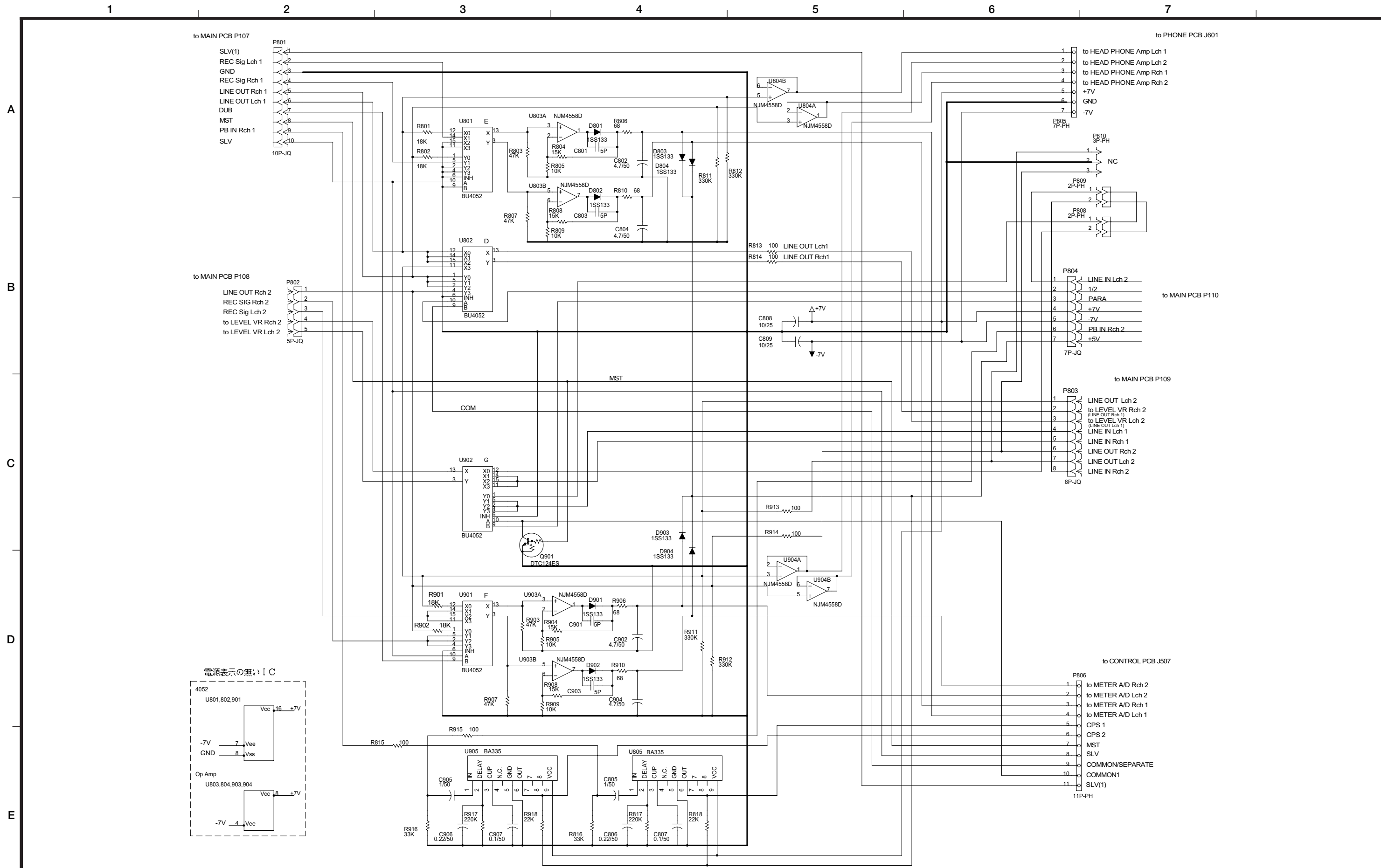

A  
B  
C  
D  
E

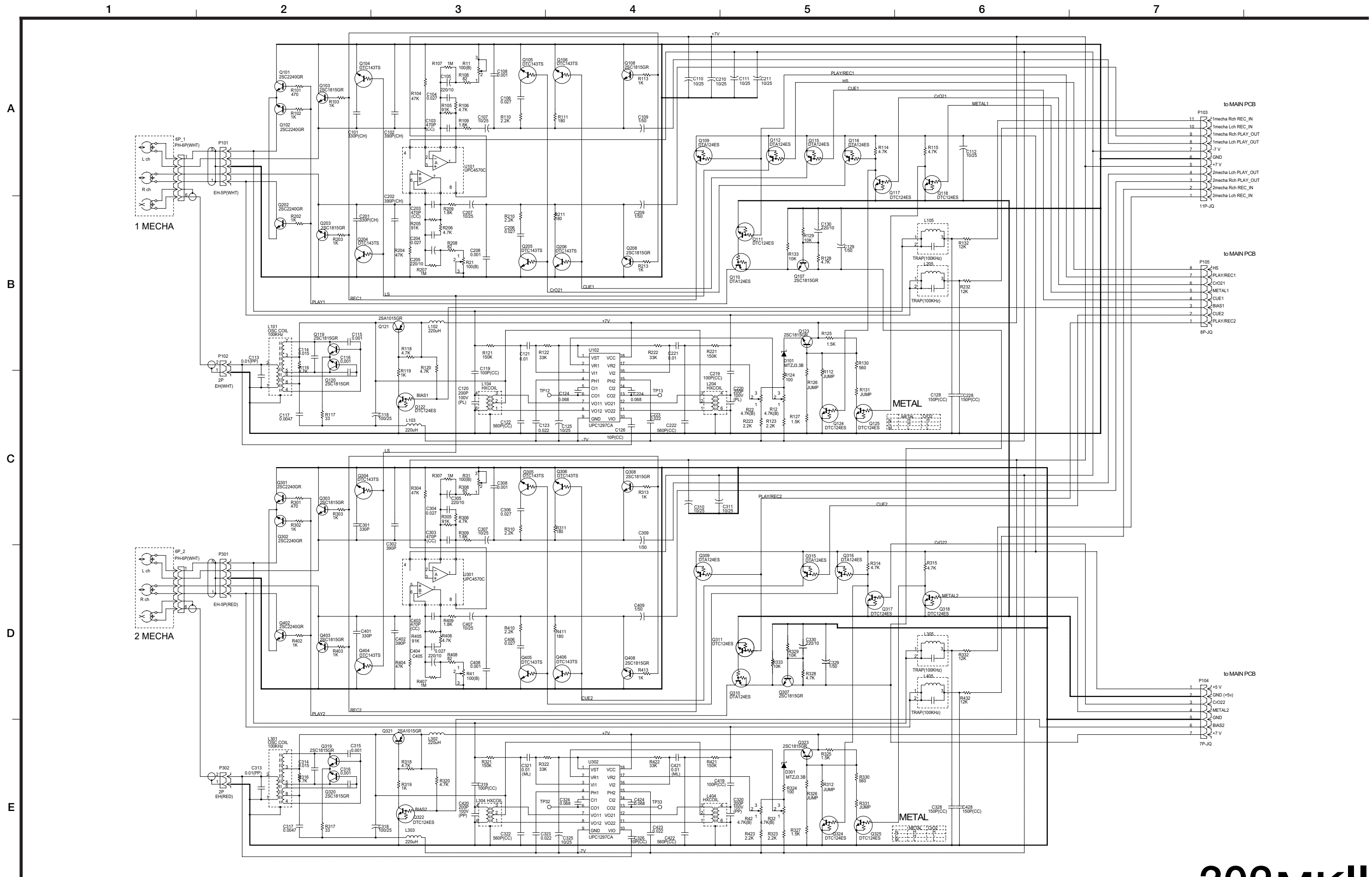

**Double Auto Reverse Cassette Deck 302MKII**



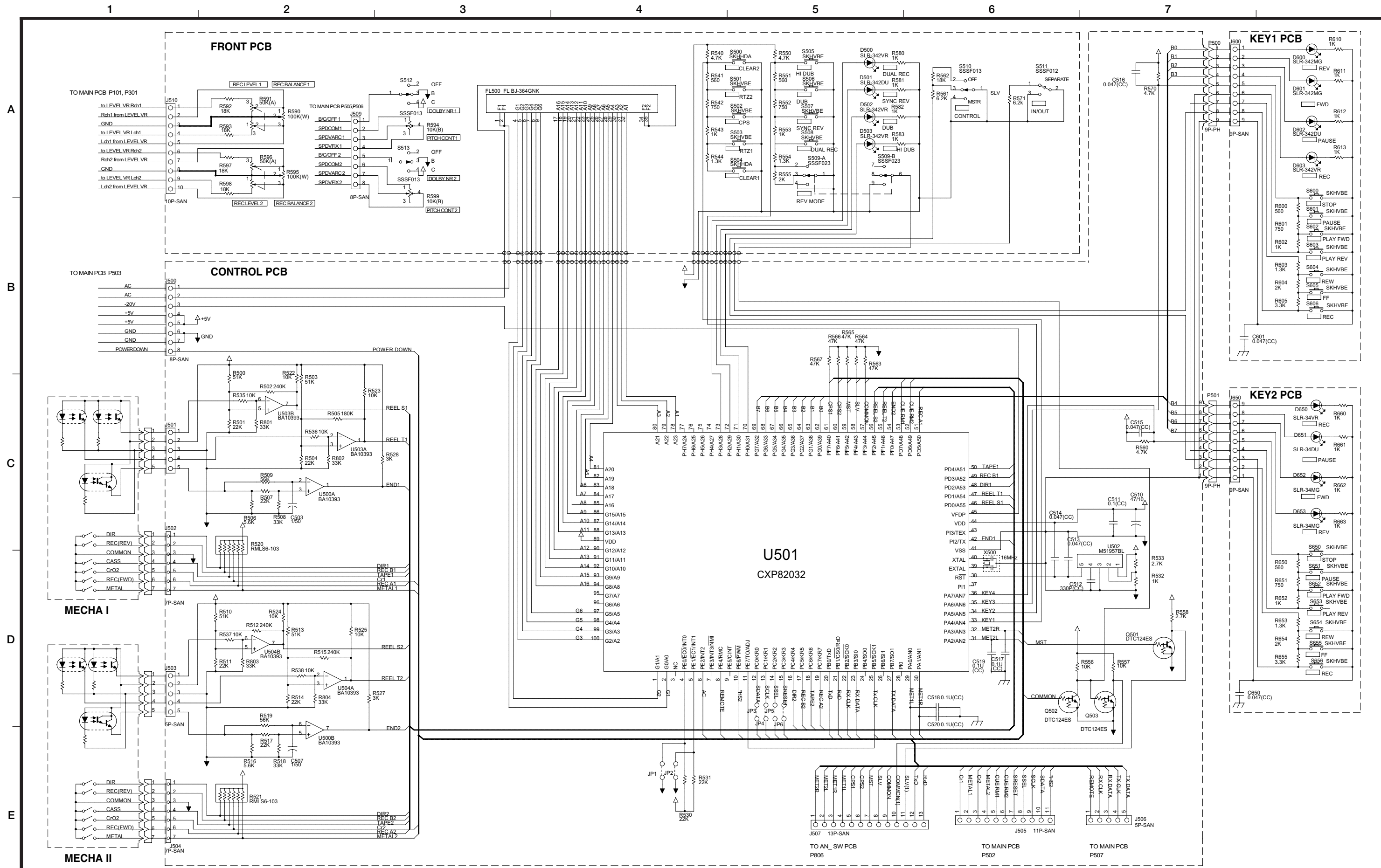

# Double Auto Reverse Cassette Deck 302MKII

1

2

3

4

5

6

7

A

B

C

D

E

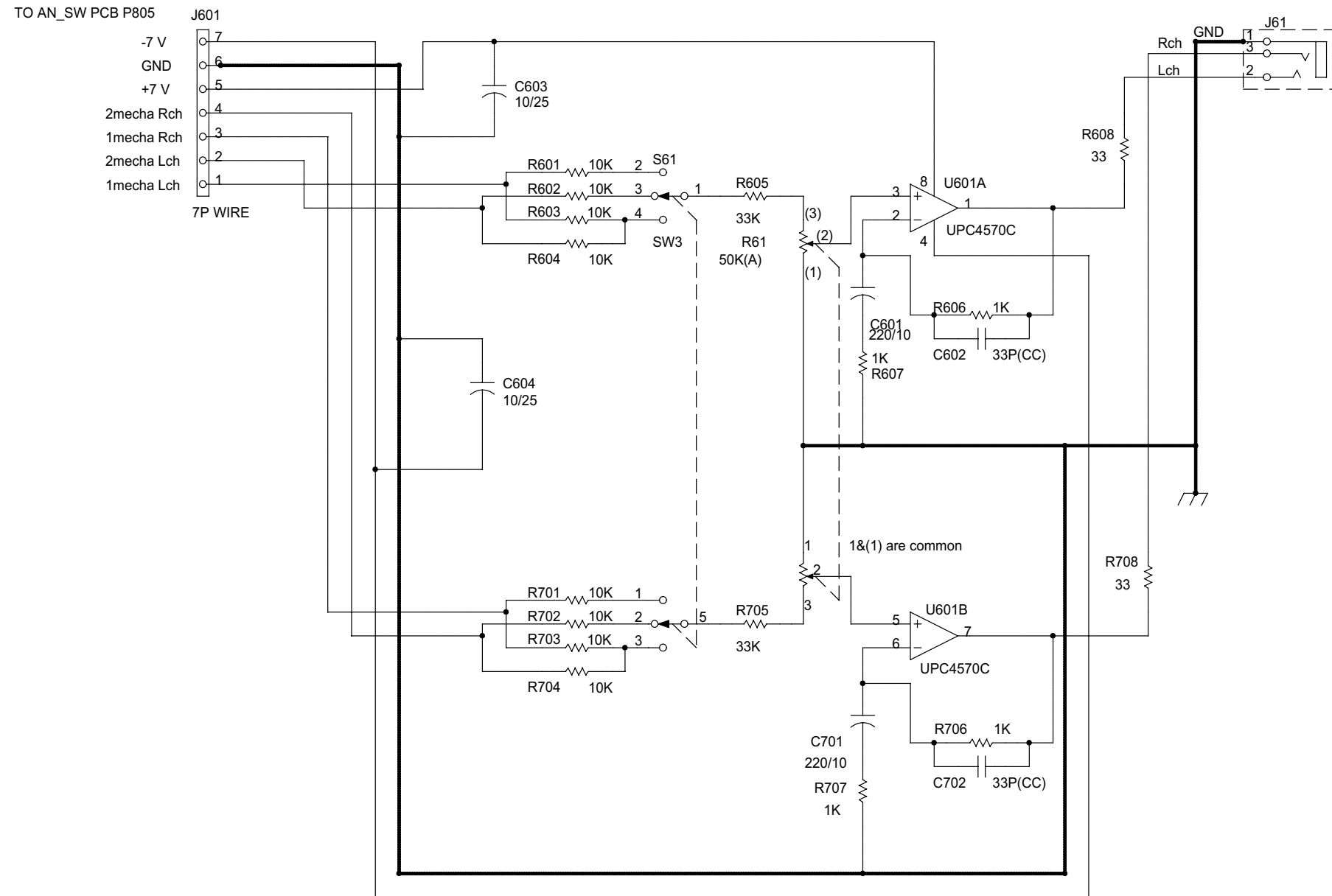

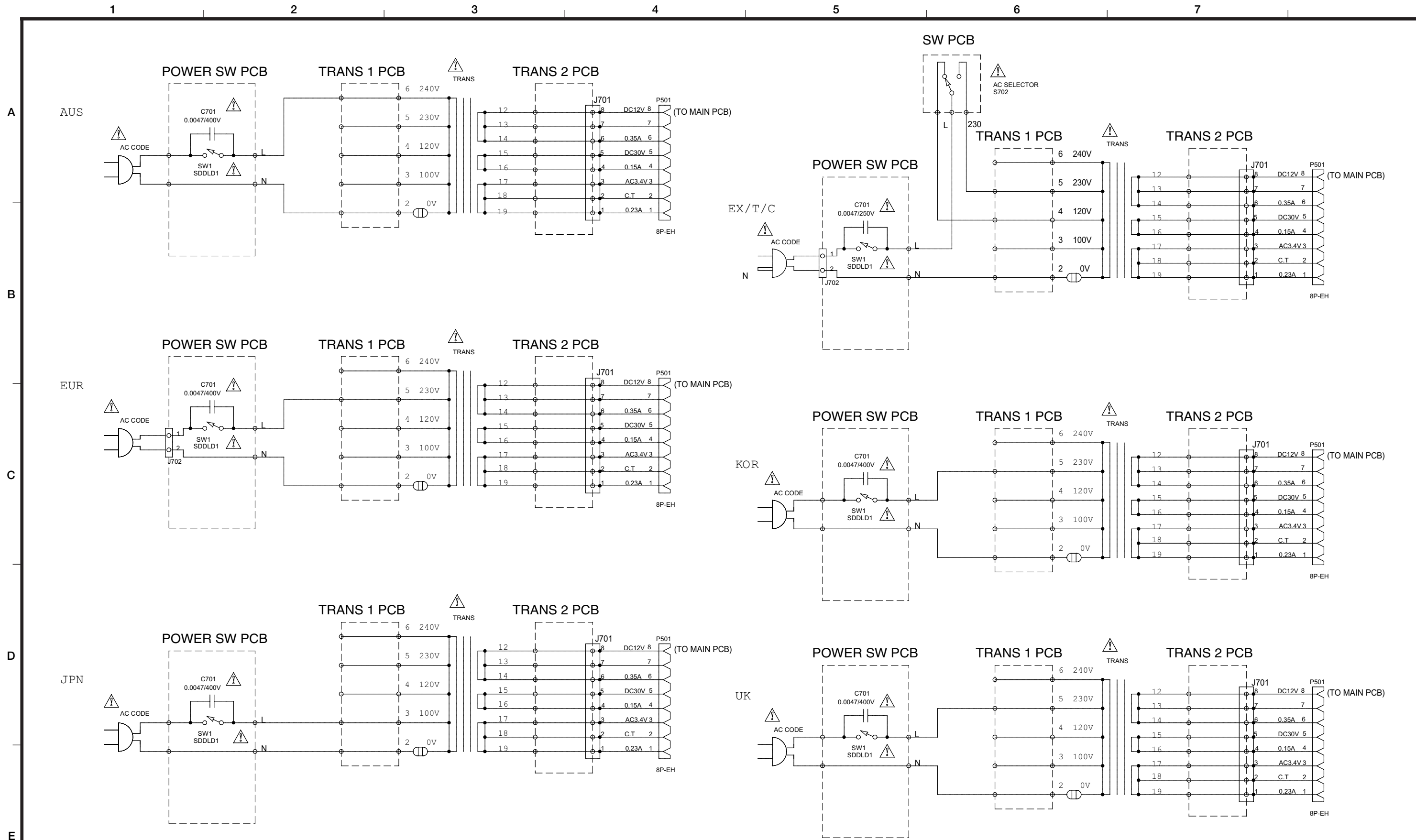

**NOTE**  
⚠ Parts marked with this sign are safety critical components. They must be replaced with identical components - refer to the appropriate parts list and ensure exact replacement.

**注意**  
⚠ マークのある部品は安全重要部品です。交換するときは必ずティアック指定の部品を使用してください。