

**HiFi ENGINE<sup>®</sup>**

For more Hi-Fi manuals and set-up information  
please visit [www.hifiengine.com](http://www.hifiengine.com)

# Technical Guide

Vol. 6

## CASSETTE DECK

### AUTOMATIC REVERSING

operation, trouble shooting,  
how to replace major parts

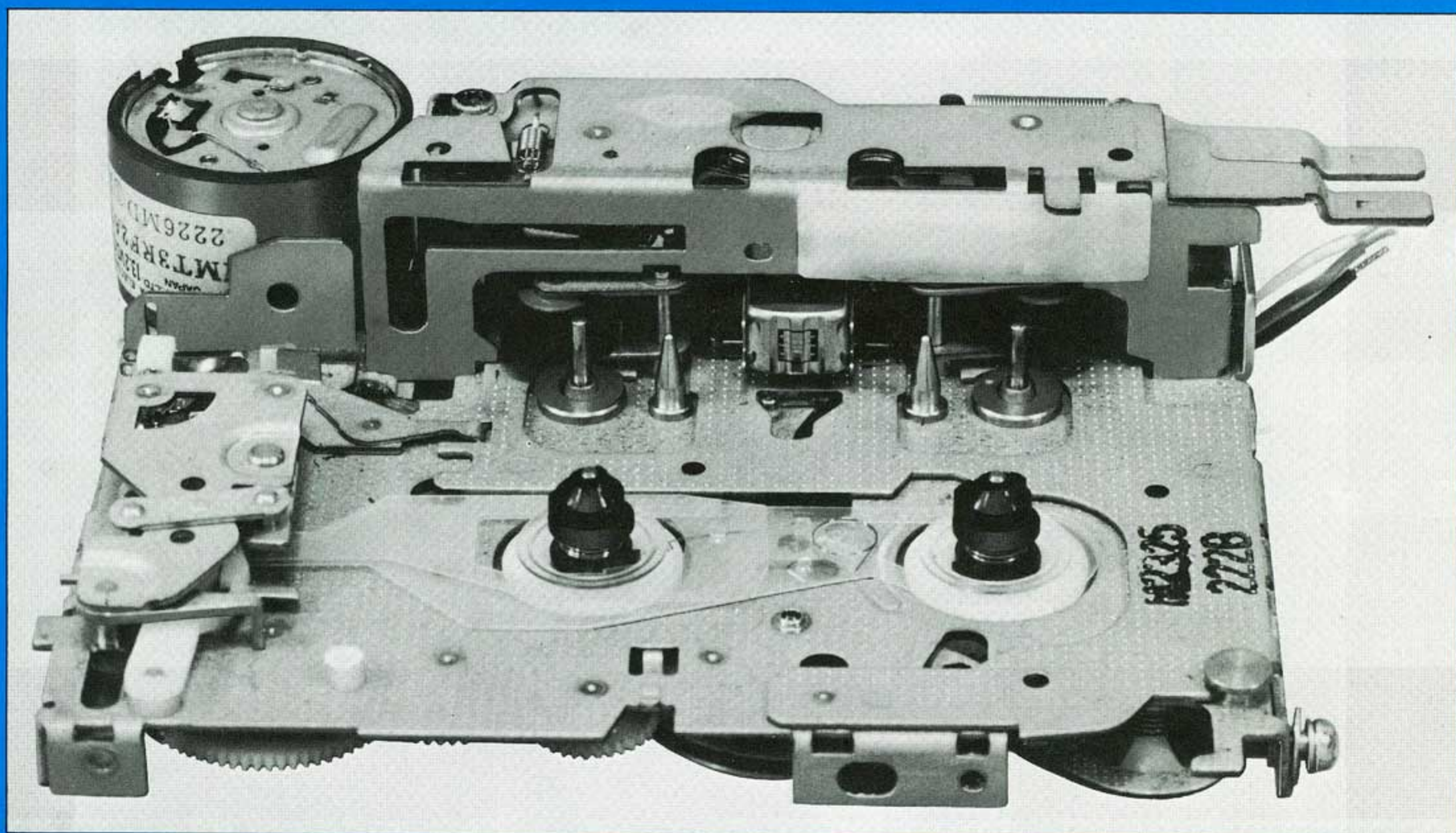

**Panasonic**

AUTO PRODUCTS DIVISION  
Matsushita Communication Industrial Co., Ltd.

<b>1</b>	AUTOMATIC REVERSING CASSETTE DECK OUTLINED FEATURES .....	4
OPERATION OF MECHANISM		
<b>2</b>	FROM TAPE INSERTION TO LOADING .....	6
<b>3</b>	THE MOTOR ROTATES AND TAPE RUNS .....	7
<b>4</b>	TAPE DRIVE ON PLAY-1 .....	8
<b>5</b>	TAPE DRIVE ON PLAY-2 .....	9
<b>6</b>	FAST FORWARD (FF) .....	10
<b>7</b>	TAPE REWIND (REW) .....	11
<b>8</b>	AUTOMATIC REVERSING .....	12
<b>9</b>	PROGRAM SELECT/MANUAL REVERSE .....	13
<b>10</b>	TROUBLE SHOOTING .....	14
<b>11</b>	HOW TO REPLACE MAJOR PARTS (1) .....	15
<b>12</b>	HOW TO REPLACE MAJOR PARTS (2) .....	16
<b>13</b>	HOW TO REPLACE MAJOR PARTS (3) .....	17
<b>14</b>	EXPLODED VIEW AND PARTS LIST (UPPER PORTION) .....	18
<b>15</b>	EXPLODED VIEW AND PARTS LIST (LOWER PORTION) .....	20

1

# AUTOMATIC REVERSING TAPE DECK

## OUTLINED FEATURES

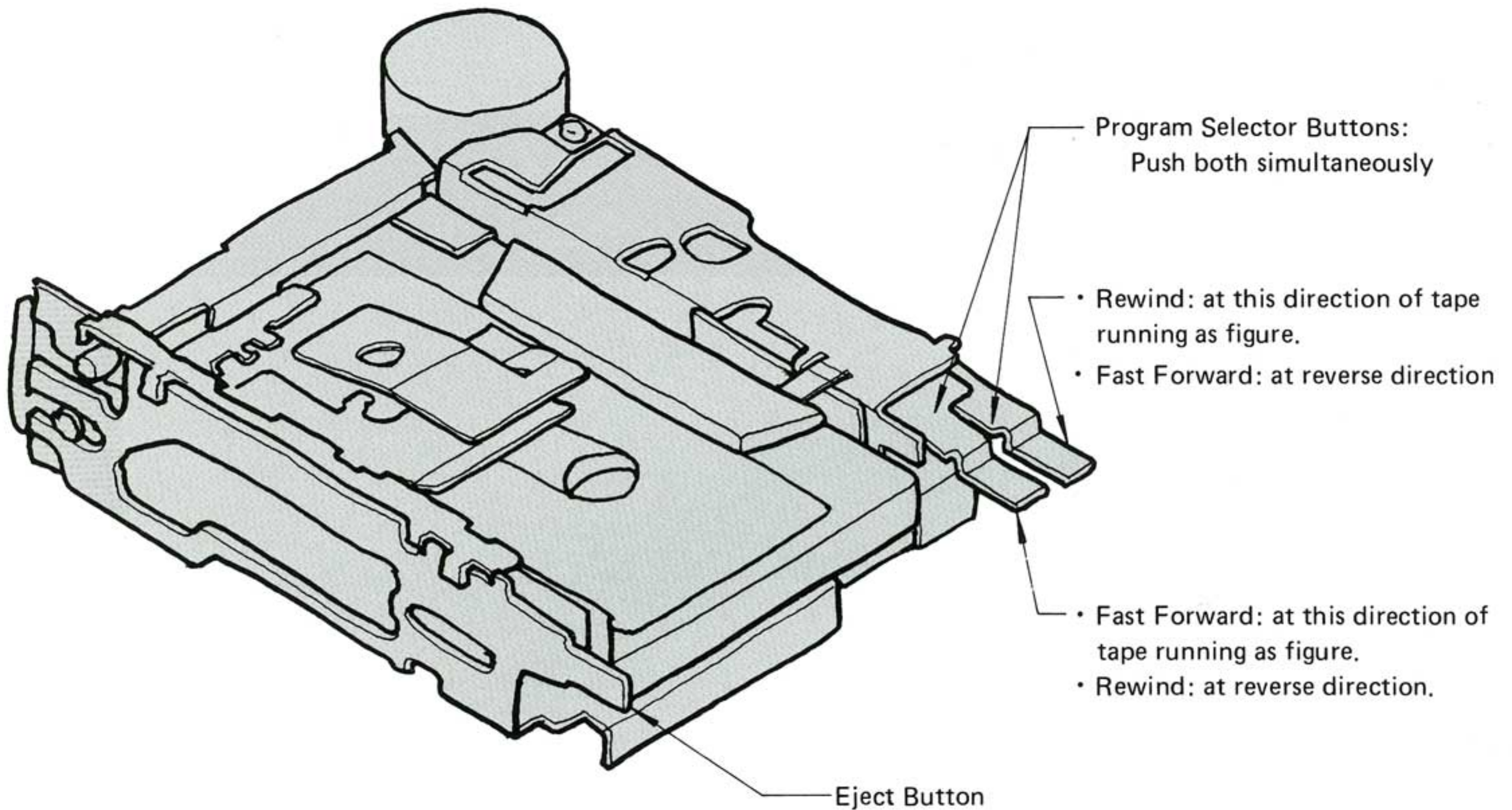

- A 4 track, 2 program, 2 channel stereo cassette tape can be played back continuously with Auto Reverse.
- A cassette tape slot-in system is employed, allowing automatic performance (playback) by inserting a cassette tape (after the main power switch has been turned ON if provided).
- A lock system is employed for tape fast forward. The system automatically releases the lock at the end of a cassette tape, automatically changes its running direction and then plays the other side.
- A lock system is employed for tape rewind. The system automatically releases the lock, and replays the side being played back without changing the tape running direction.
- Program change-over may be done manually. In addition, automatic change-over is conducted at the end of a tape (manual change-over is conducted by depressing the fast-forward/rewind buttons simultaneously).

**AUTO REVERSE**

**TAPE PLAYER WITH RADIO**

**PLAYER**

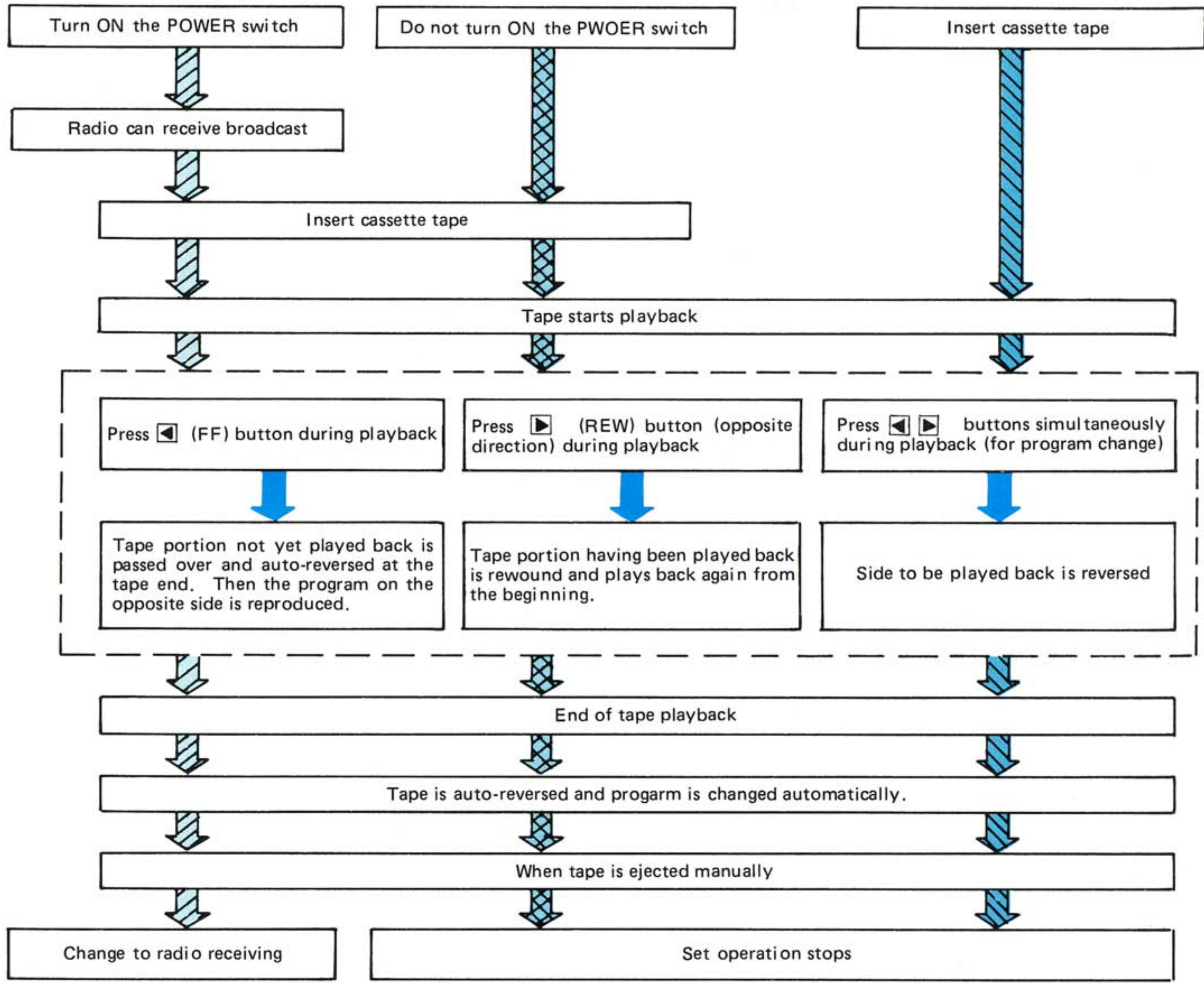

2

OPERATION OF MECHANISM  
from TAPE INSERTION to LOADING

① Insert a cassette tape.

② The tape holder lock is released by the cassette tape.

③ The tape holder section is pushed in the direction of insertion.

④ When the tape holder section is pushed back, the tape holder drops automatically and the cassette is loaded on the reels (A) and (B).

⑤ The radio/tape selector switch provided on the deck is changed to the tape position by the actuator.

⑥ The motor rotates. (The tape-only circuits such as an equalizer or dolby circuit are turned on and the radio circuit is turned off.)

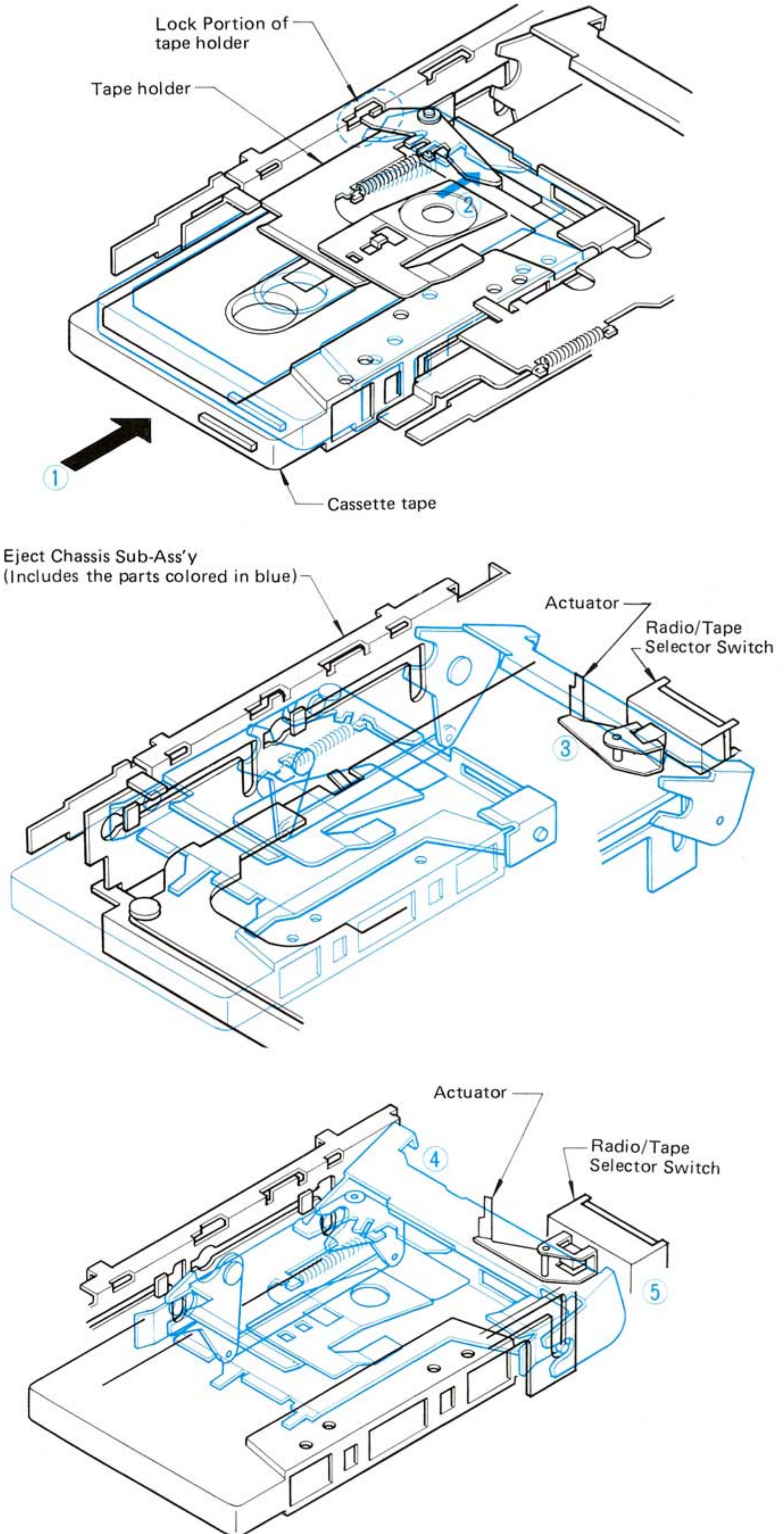

**OPERATION OF MECHANISM  
the MOTOR ROTATES and TAPE RUNS**

**3**

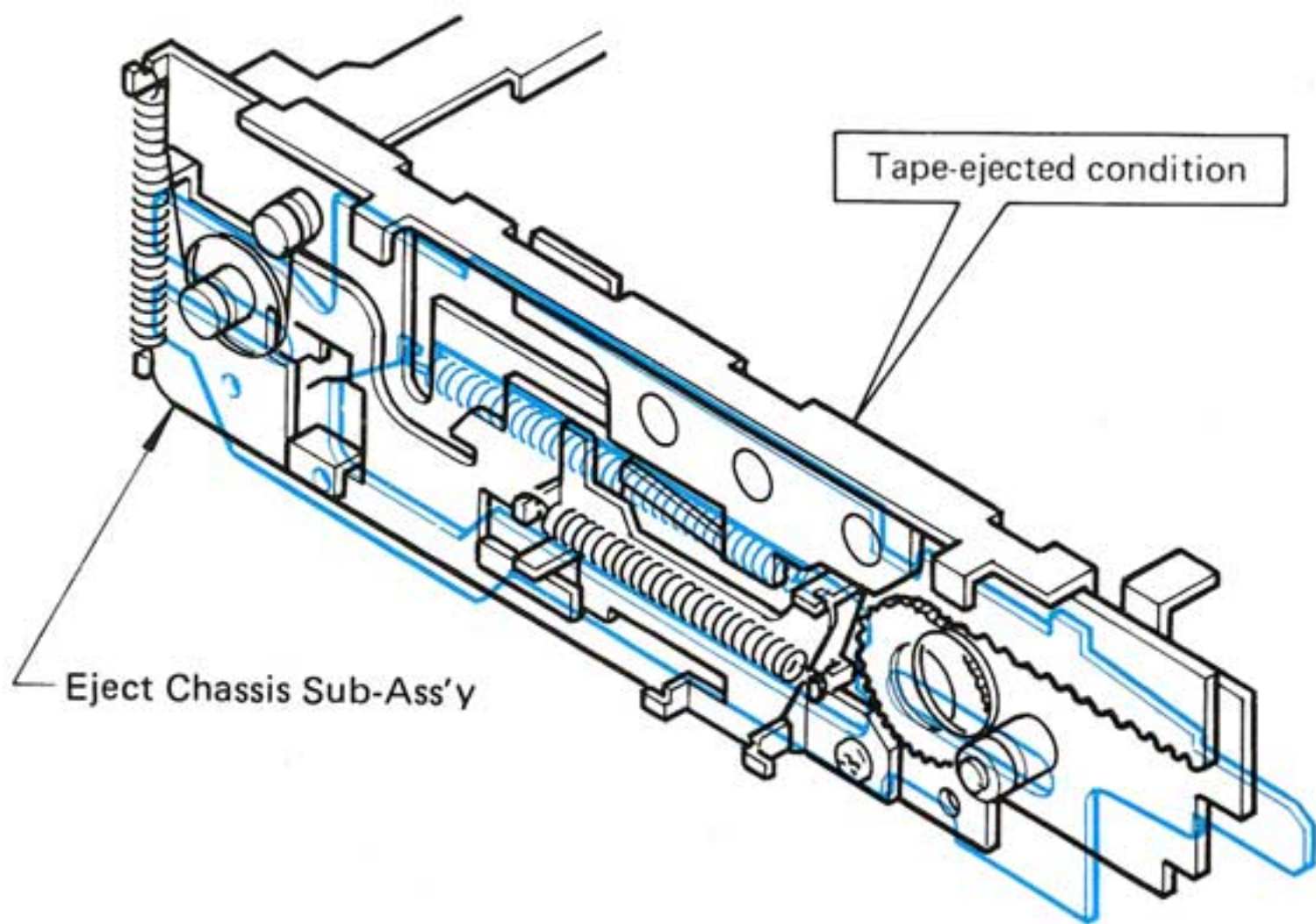

When the tape is loaded, the eject lever moves forward via the action of the eject chassis sub-assembly. ①

When the eject lever moves, its sliding wheel, which holds the head chassis assembly, moves to the release position. ②

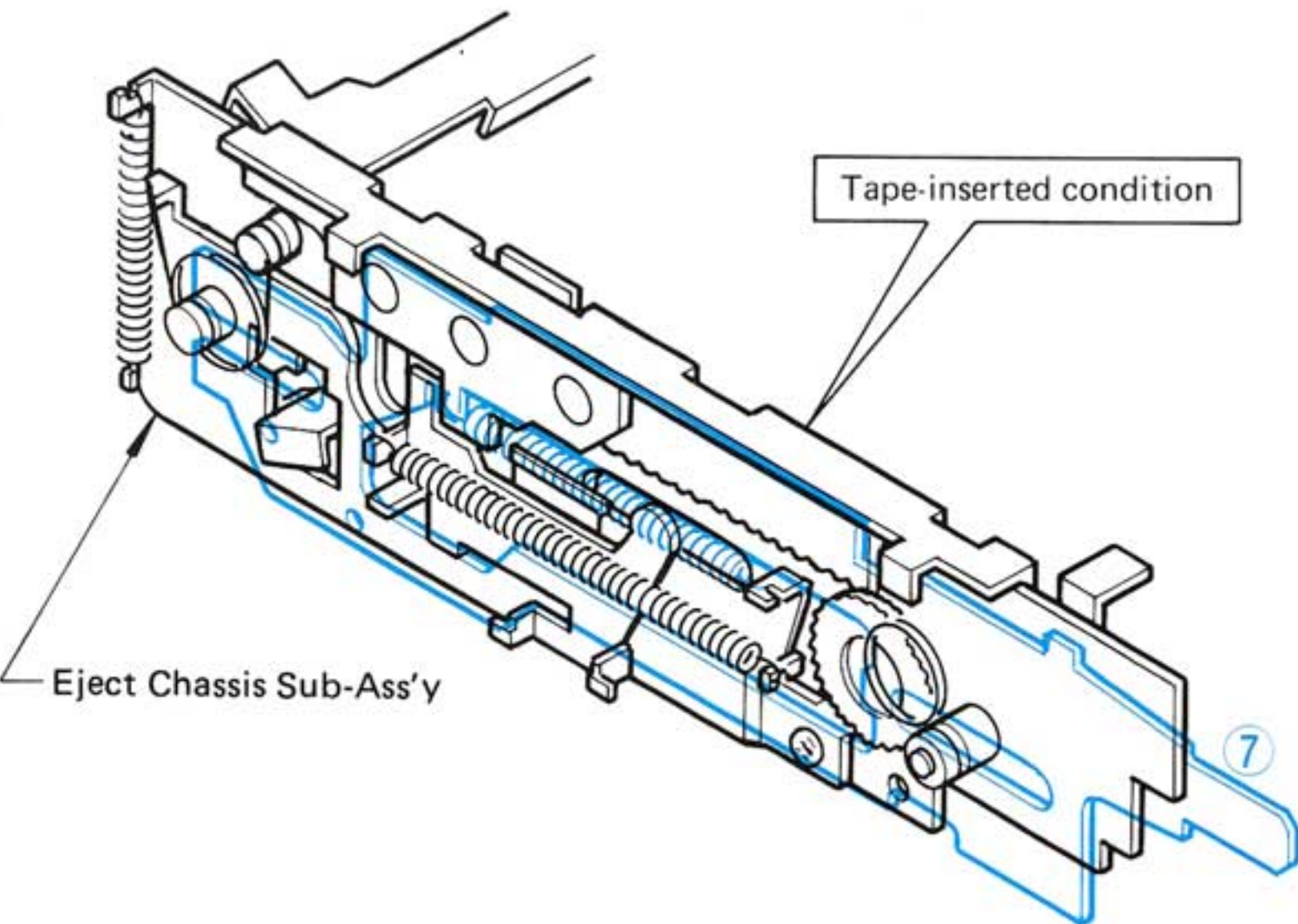

The head chassis assembly moves forward. ③

The head face comes in contact with the tape and the tape is held between the pinch roller and the capstan shaft. ④

The tape is wound in its running direction. ⑤

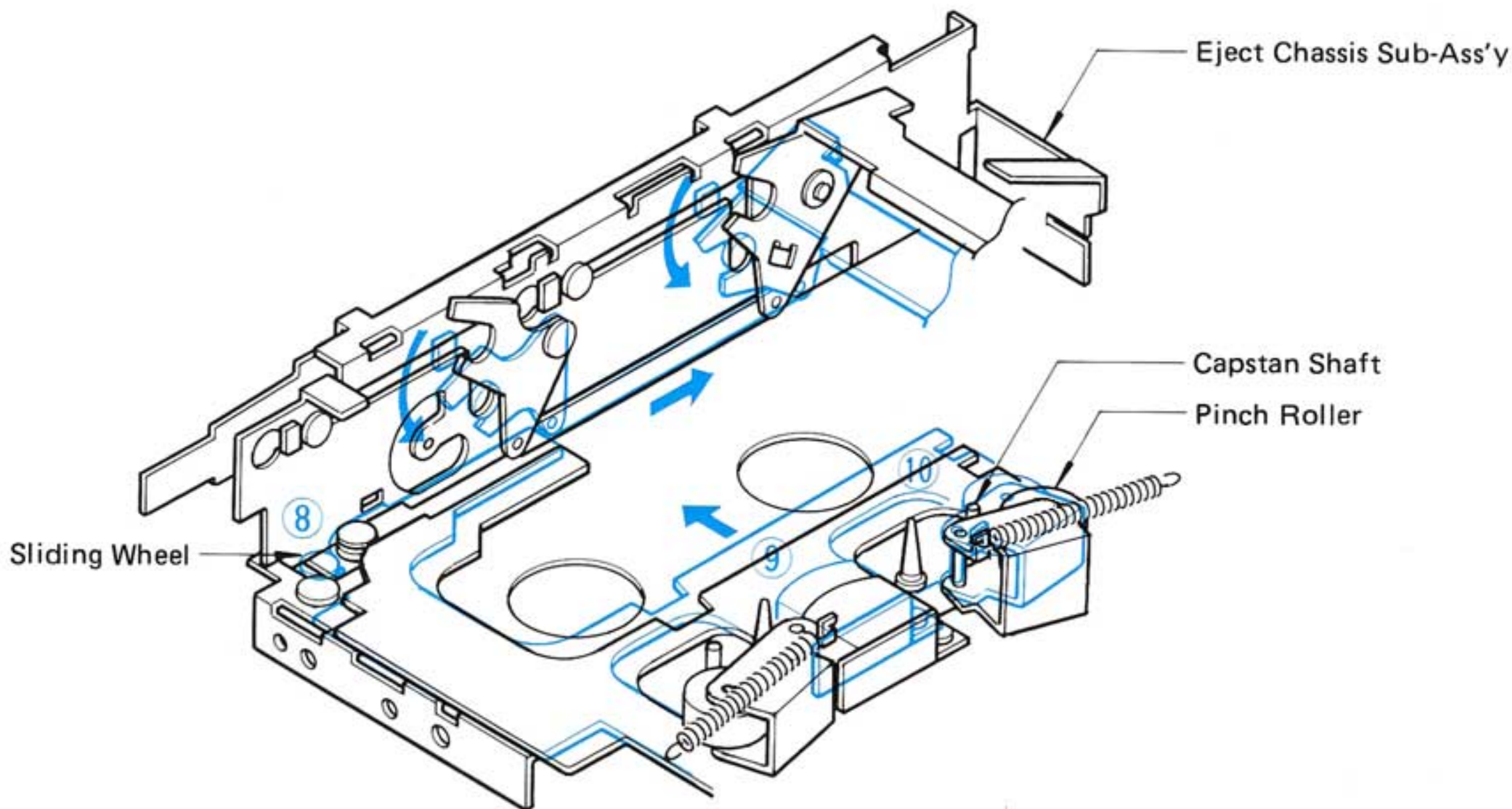

**4**

**TAPE DRIVE ON PLAY-1**

How the rotation from the motor is transmitted (The illustrations on this page are bottom views of the deck.)

When a tape is wound on the reel (A) assembly.

The action of the play reverse lever assembly engages the play idler gear with the reel (A) assembly gear, transmitting the rotation of the middle wheel to the reel (A) assembly.

The tape is wound on the reel (A) assembly.

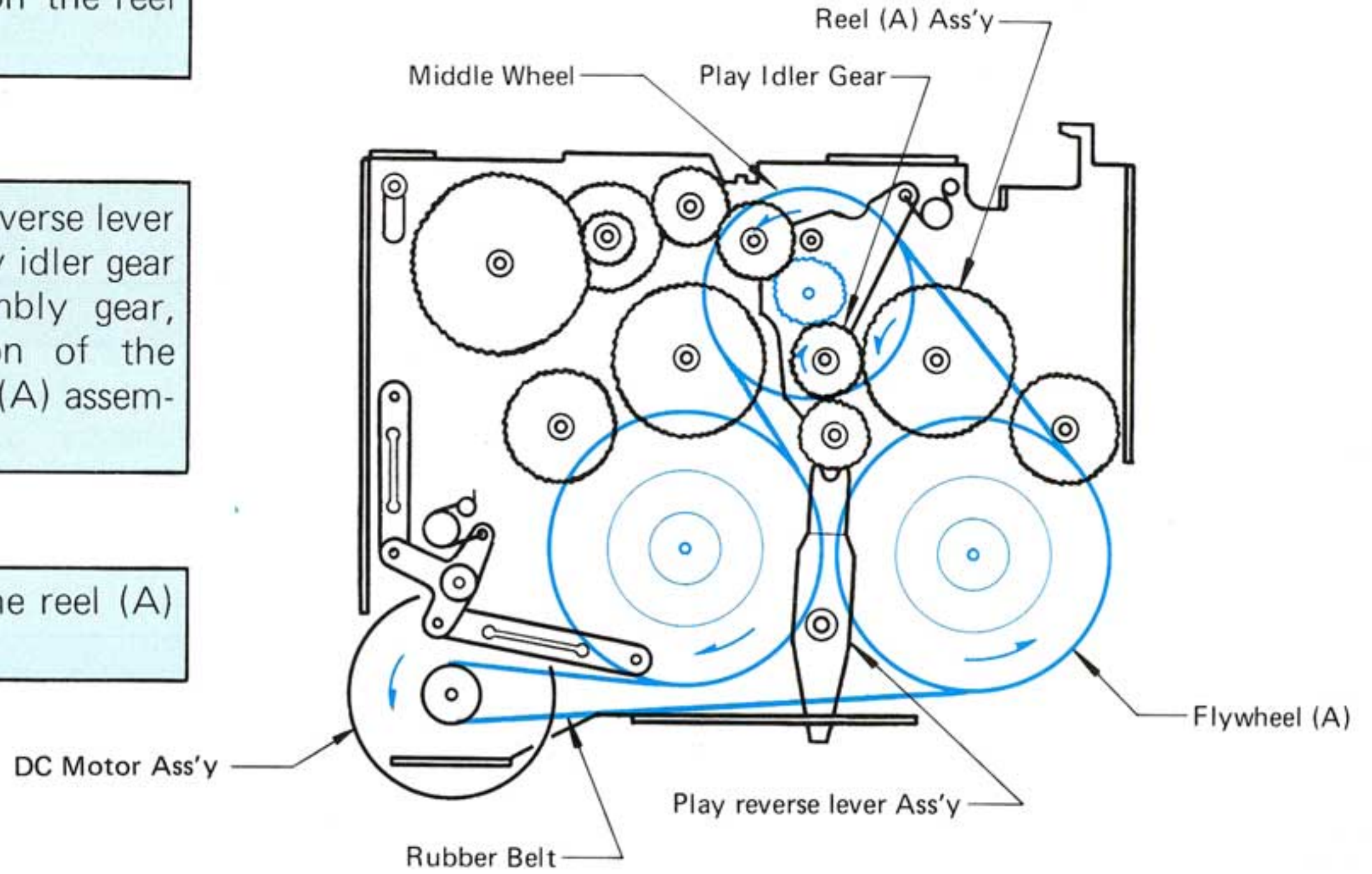

▲ The pinch roller (B) assembly at the side of the flywheel (A) is in close contact with the capstan shaft which also serves as the shaft of the flywheel (B).

When a tape is wound on the reel (B) assembly.

The action of the play reverse lever assembly engages the play idler gear (B) with the reel (B) assembly gear, transmitting the rotation of the middle wheel to the reel (B) assembly.

The tape is wound on the reel (B) assembly.

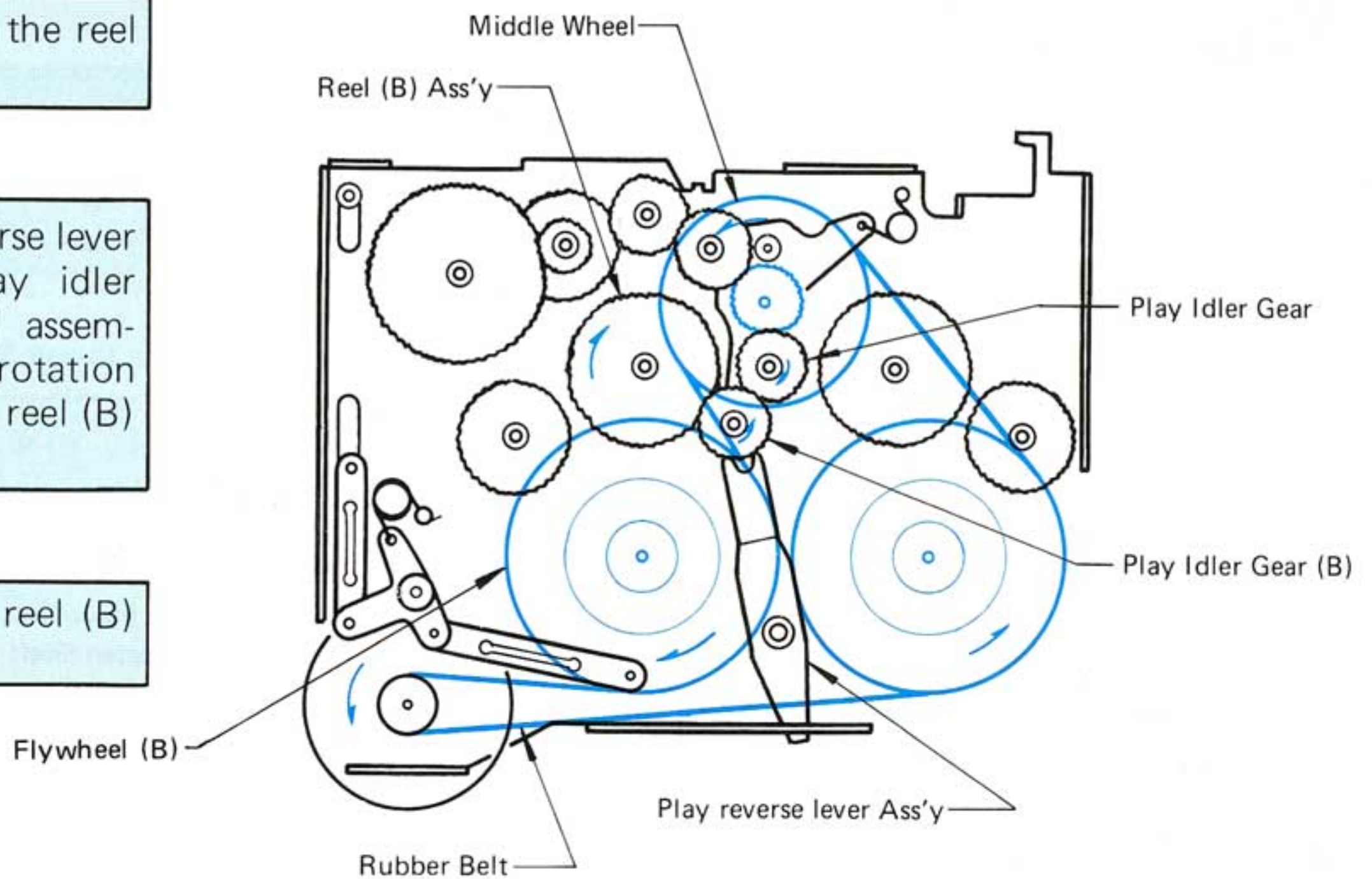

▲ The pinch roller (B) assembly at the side of the flywheel (B) is in close contact with the capstan shaft which also serves as the shaft of the flywheel (B).



## TAPE DRIVE ON PLAY-2

5

Determination of Tape Running Direction by Pinch Roller.

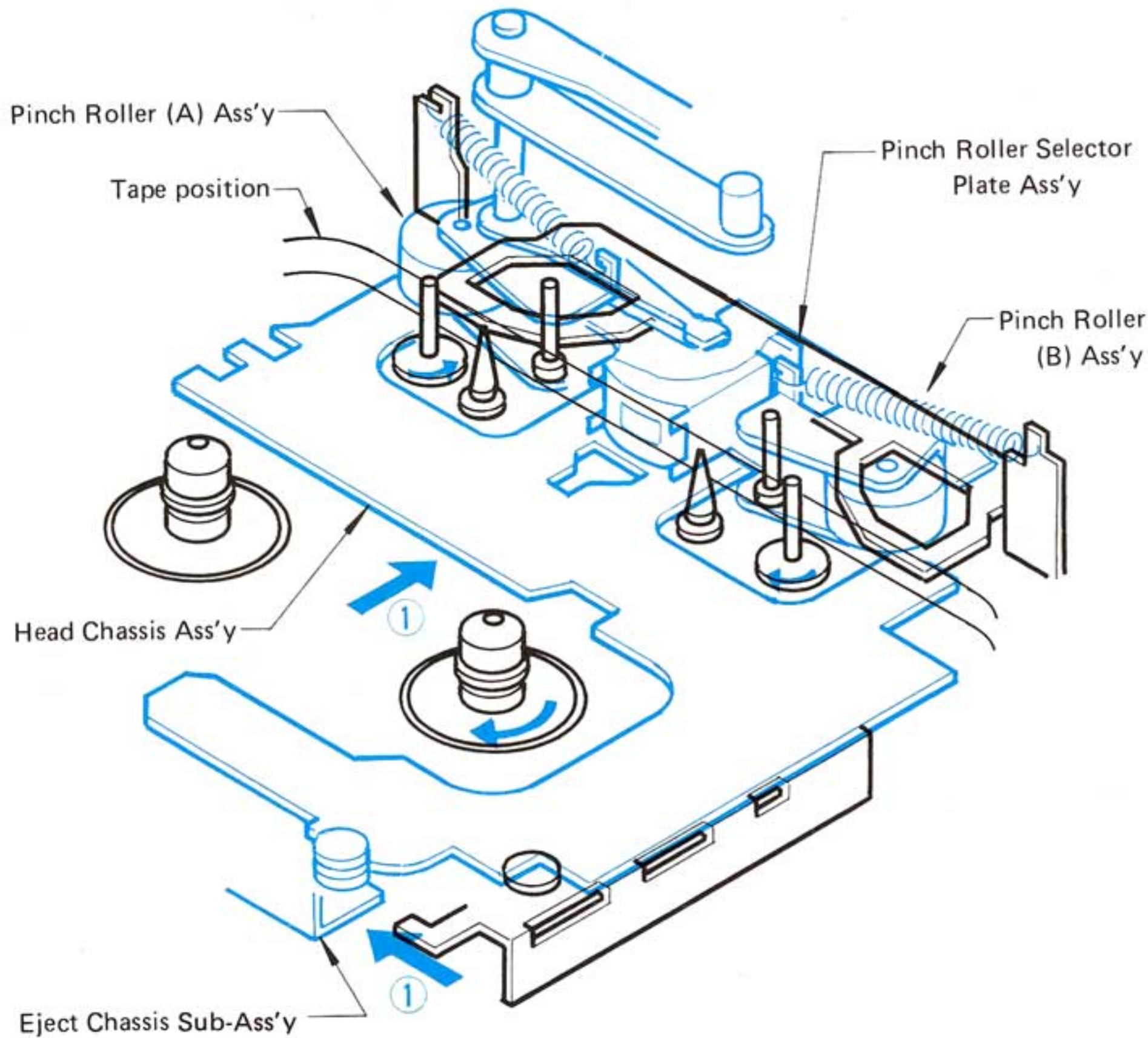

① Before tape insertion, the head chassis assembly is held in its retracted position by the eject chassis sub-assembly.

② When a tape is inserted, the eject chassis sub-assembly separates from the head chassis assembly, moving the latter forward. At this time, either pinch roller (A) or (B) comes in close contact with the capstan shaft depending upon the position of the pinch roller selector plate assembly.

- In this figure, the pinch roller (B) is in close contact.
- Interlocked with the auto-reverse mechanism, the pinch roller selector plate assembly slides forward and backward in the direction parallel with the tape.

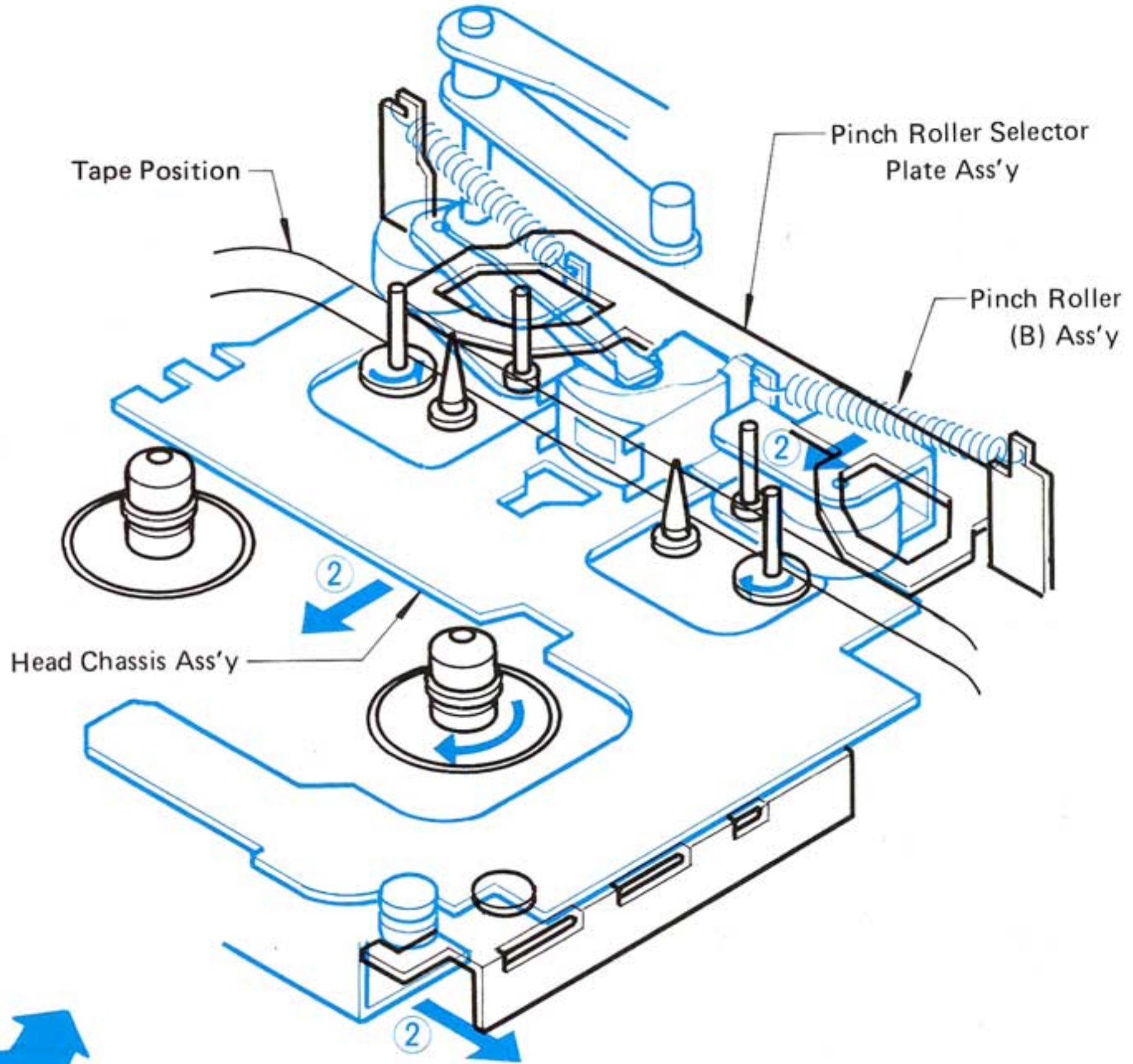

The capstan shaft together with the flywheel, rotate by means of a belt when the motor rotates.

The tape is wound on the side where the capstan shaft and the pinch roller are in close contact.

The deck is designed so that only the reel to which the tape is sent rotates for winding it. The other reel turns freely.

## AUTO REVERSE

### NOTE:

When a tape is running in the direction of the reel (A) assembly, following the operation below causes a rewind condition.

# 6

## FAST FORWARD (FF)

The figure below shows the condition in which a tape is running in the direction of the reel (B) assembly.

- ① When you want to interrupt the playback of a tape to obtain a Fast Forward condition.
- ② Depress the button which corresponds to the FF operation of the FR chassis sub-assembly.
- ③ The button is locked in the depressed position.
- ④ The head chassis assembly retracts and the pinch roller (A) assembly leaves the capstan.
- ⑤ When the head chassis assembly retracts, it moves the play reverse lever assembly, releasing the play idler gear (B) from the reel (B) assembly gear.
- ⑥ When the FF operation button is depressed the depressing force is transmitted to the FR reverse lever (A) assembly, engages the gear incorporated into the FR idler lever (A) assembly with the gear around the flywheel (B) and the reel (B) assembly gear, winding the tape.
- ⑦ When the FF operation of the tape is completed, a tape end condition results and the auto reverse functions to change the tape running direction. For the auto reverse, see page 12.

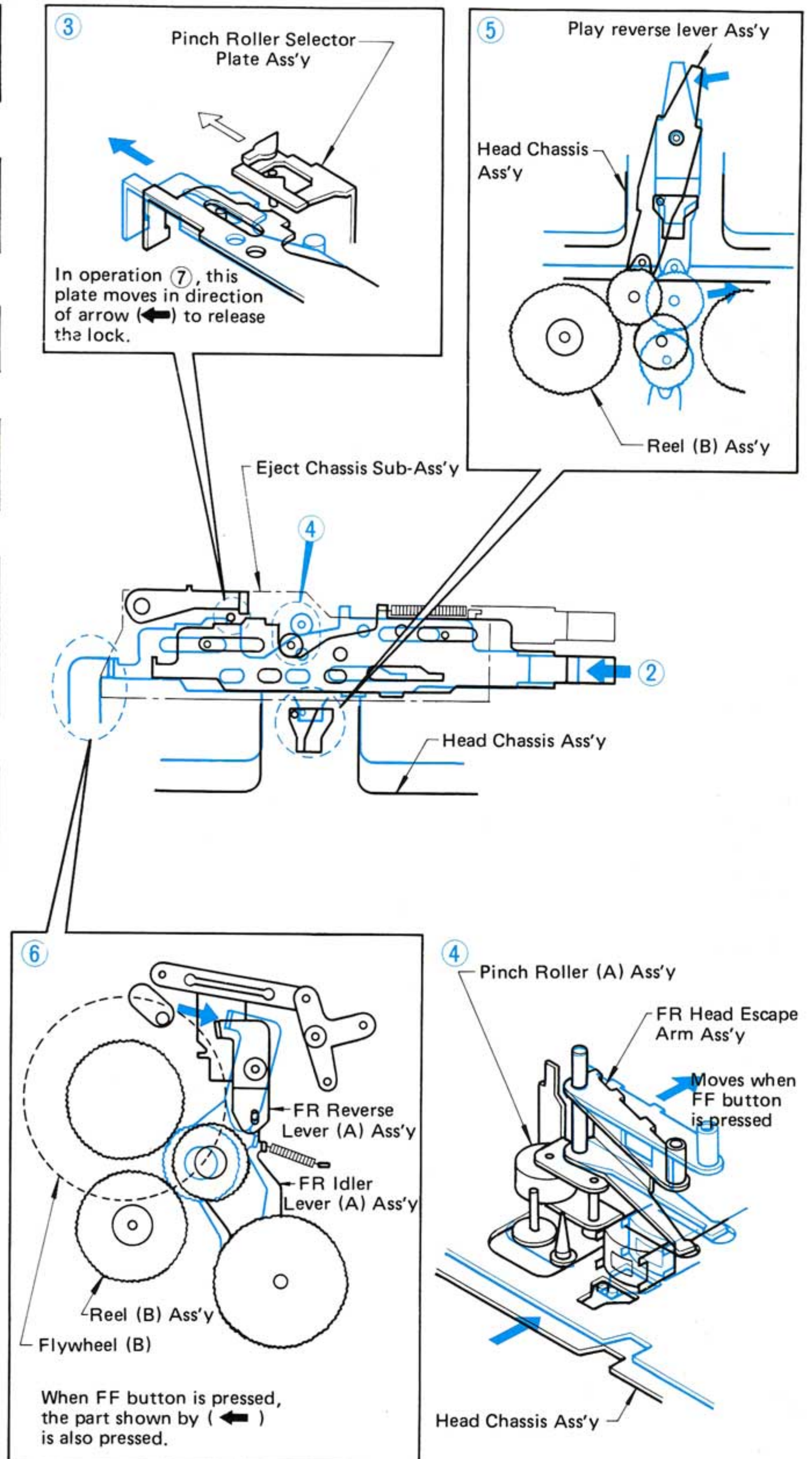

**TAPE REWIND (REW)**

The figure below shows the condition in which a tape is running in the direction of the reel (B) assembly.

**7** NOTE:  
When a tape is running in the direction of the reel (A) ward (FF) condition.

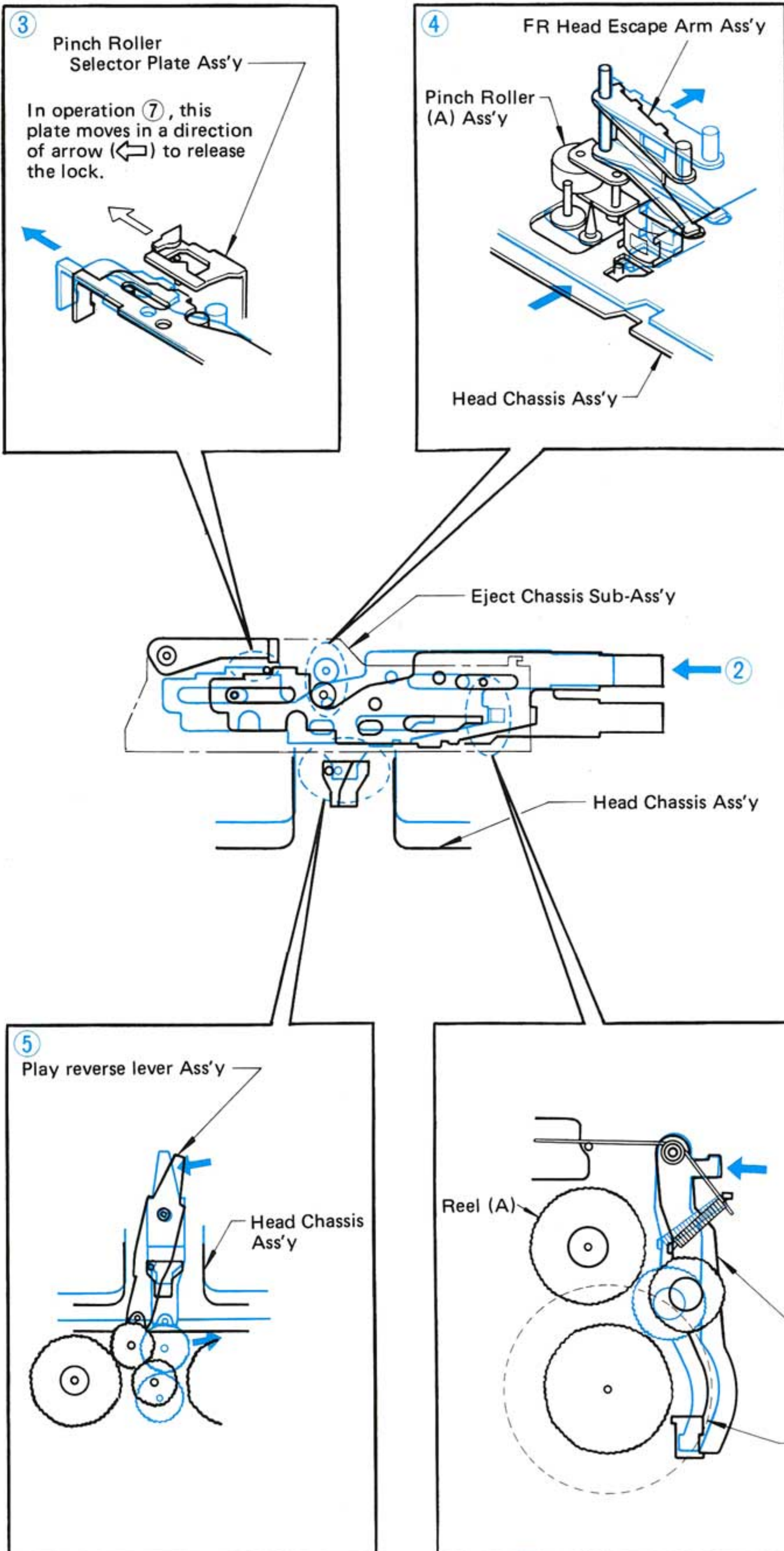

- ① When you want to interrupt the playback of a tape to rewind it.
- ② Depress the button which corresponds to the REW operation of the FR chassis sub-assembly.
- ③ The button is locked in the depressed position.
- ④ The head chassis assembly retracts and the pinch roller (A) assembly leaves the capstan.
- ⑤ When the head chassis assembly retracts, it moves the play reverse lever assembly, releasing the play idler gear (B) from the reel (B) assembly gear.
- ⑥ When the REW operation button is depressed, the depressing force is transmitted to the FR idler lever (B) assembly, engaging the gear incorporated into this lever with the gear around the flywheel (A) and the reel (A) gear to wind the tape.
- ⑦ When the REW operation of the tape is completed, the auto reverse functions. With the tape in its end condition, however, the auto reverse functions again, without changing the tape running direction.

**8**

**AUTOMATIC REVERSING**

This description is for a condition in which a tape is being wound by the reel (B) assembly. If the tape is being wound by the reel (A) assembly, the carriage assembly moves in the opposite direction (from color print to back print).

- ① The tape reaches its end.
- ② The reel (B) assembly stops rotating.
- ③ The reel (B) assembly catch portion stops idling, and the catch is caught by the detecting link (A).
- ④ The detecting link (A) pulls in the direction of → (direction of motor)
- ⑤ The detecting cam engages with the detecting cam shaft assembly.
- ⑥ The trigger lever fits the carriage assembly rack lever (A) into the detecting shaft assembly gear.
- ⑦ Through the rotation of the detecting cam shaft assembly detecting gear, the carriage assembly moves in the direction of →.
- ⑧ The movement of the carriage assembly is transferred to joint plate (B).
- ⑨ This rotates the tri-link until passes the tri-link spring dead point.
- ⑩ The joint plate (A) moves to move the pinch roller selector plate assembly in the direction of →.
- ⑪ The play reverse lever assembly also moves, the play idler gear (B) leaves the reel (A) assembly, and the play idler gear engages with the reel (A) assembly gear.
- ⑫ The reverse switch is changed over by the reverse switch spring.
- ⑬ The auto reverse cycle is completed, and the program on the other side is played.

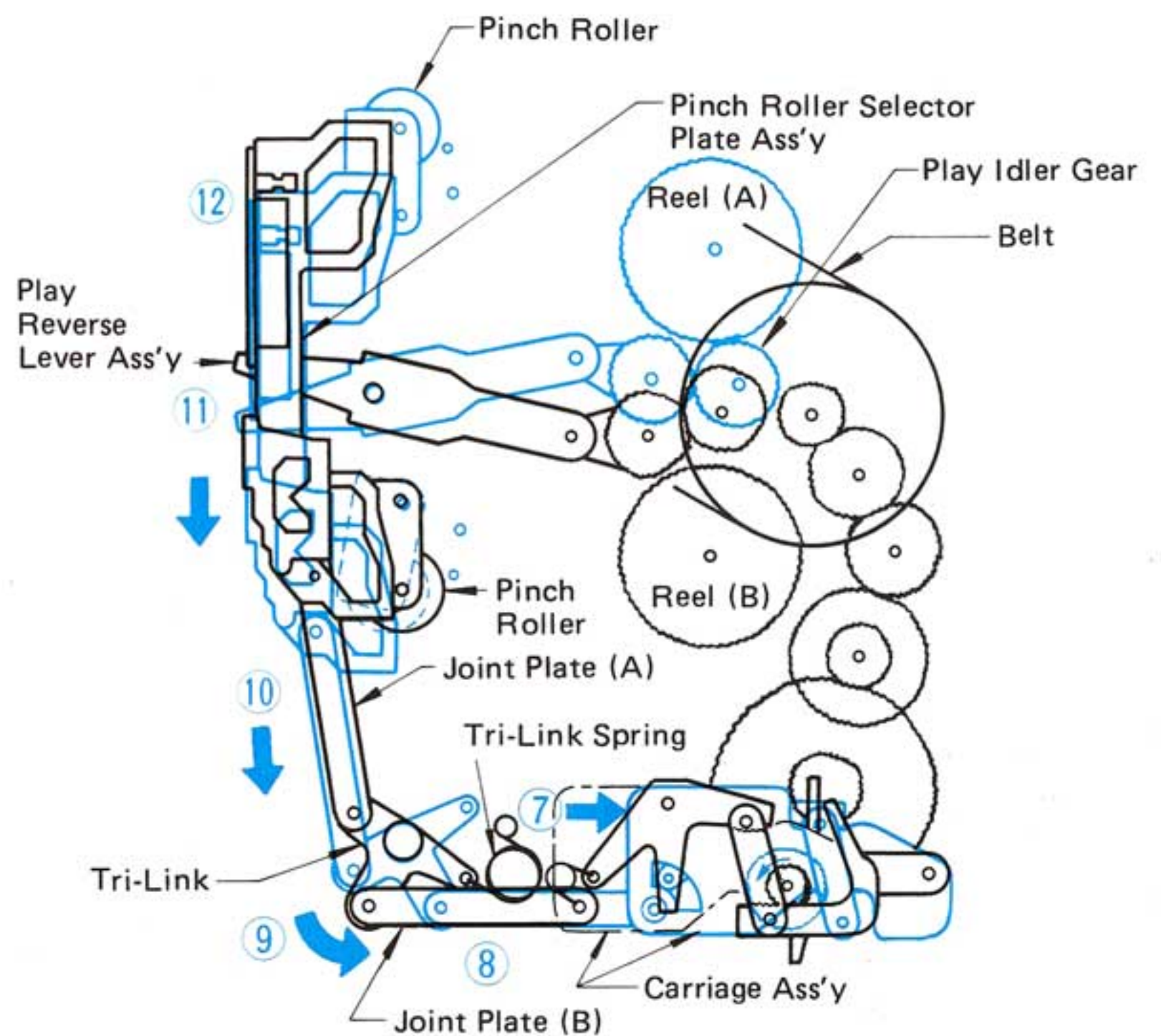
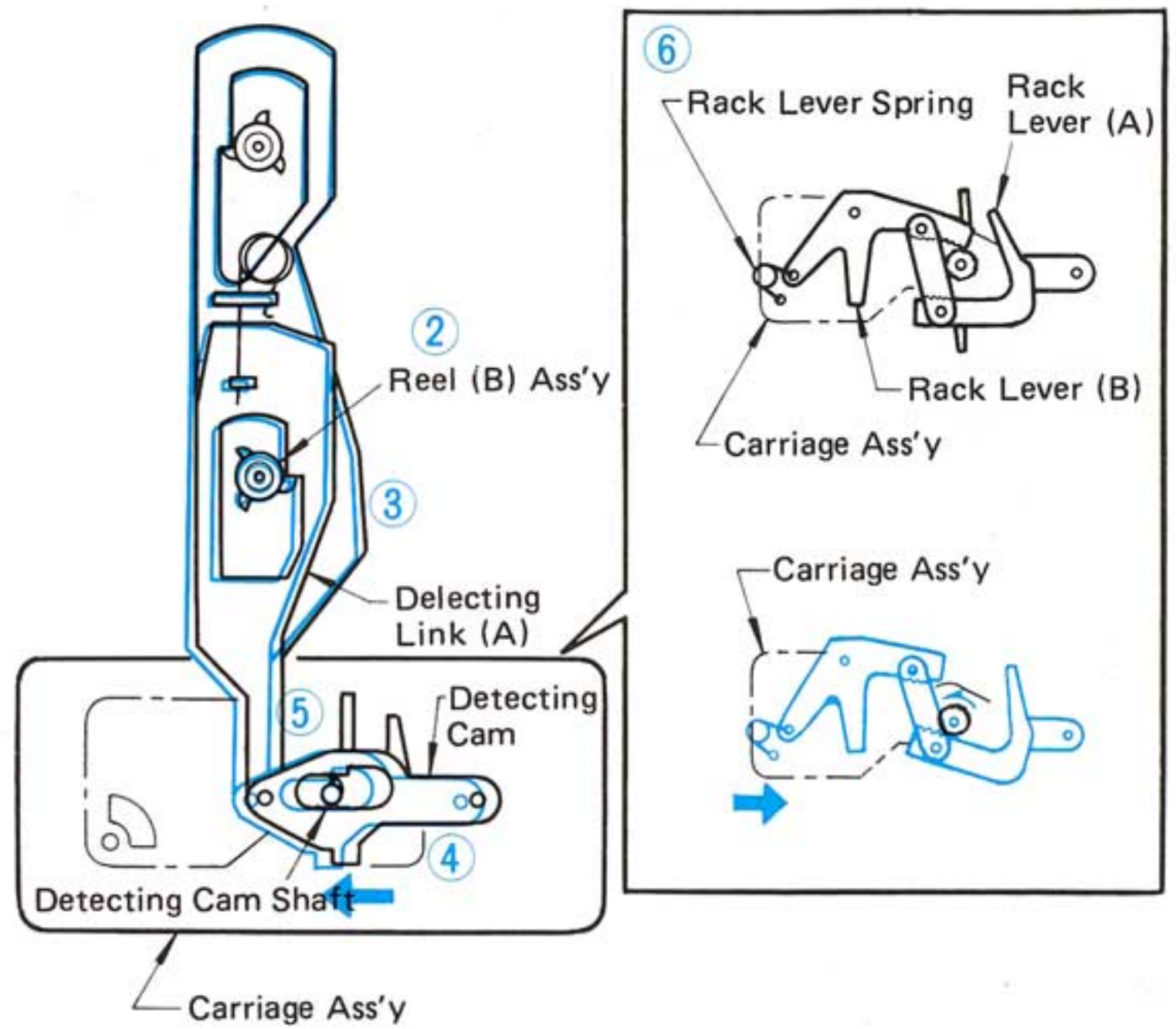

**PROGRAM SELECT/MANUAL REVERSE**

**9**

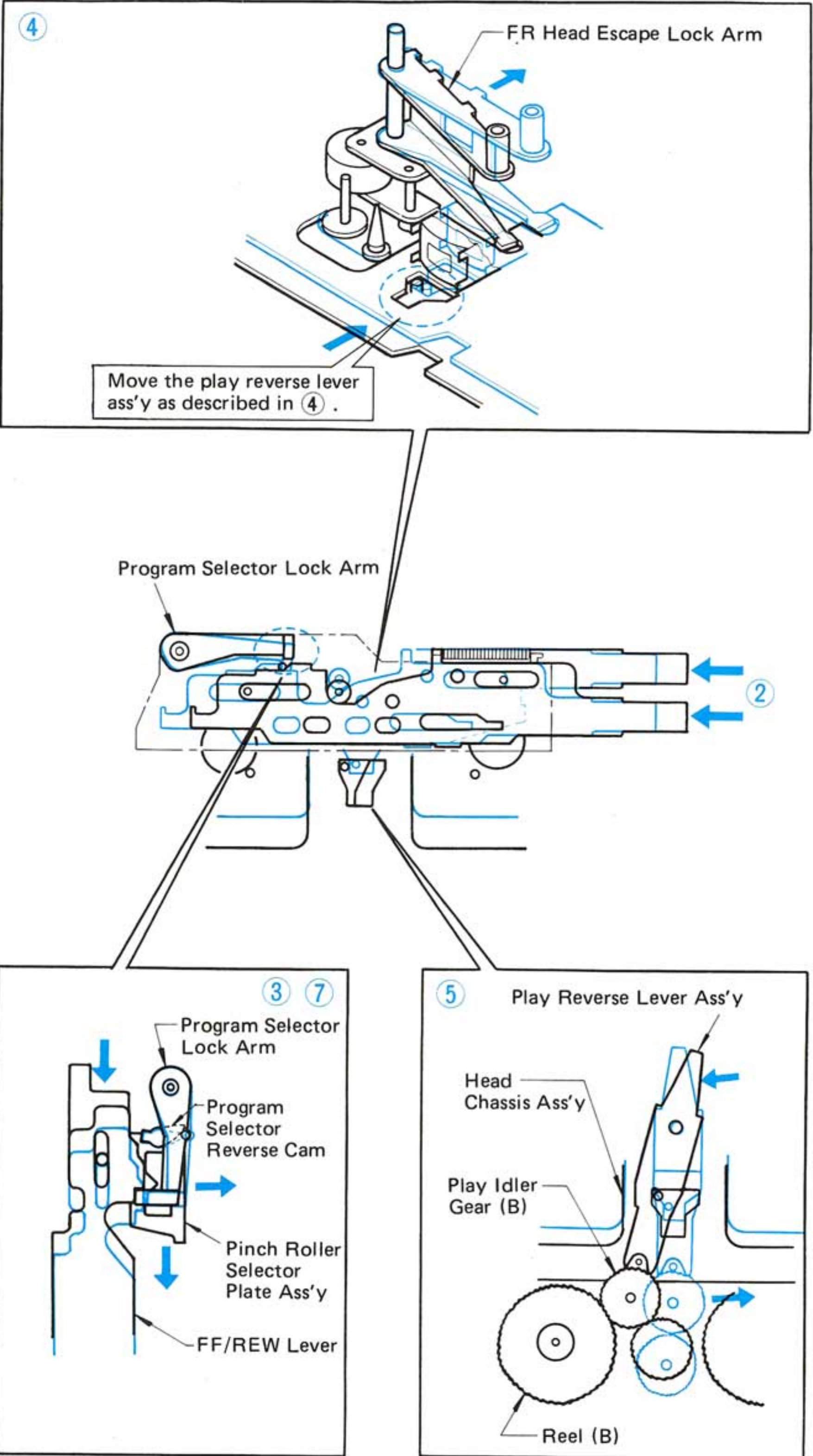

When you want to reverse the running direction at a certain point during a tape while playing. ①

Depress the FF/REW levers simultaneously. This retracts the head chassis assembly by means of the FR head escape lock arm assembly shaft. ②

The FF/REW levers lock with the program selector lock arm. ③

When the head chassis assembly retracts, it moves the play reverse lever assembly in the direction of → ④

The play idler gear (B) leaves the reel (A) assembly gear and stops rotating which causes a tape-end condition in the course of the playback. ⑤

The running direction changes through the operations ① to ⑬ on page 12. ⑥

When Item ⑩ of the above operation (see page 12) is carried out, the program selector release cam end contacts the program lock arm, releasing the lock of the FF/REW levers. ⑦

The program change-over cycle is completed, and the program on the other side is played. ⑧

SYMPTOM	CAUSE	REMEDY
No output when cassette tape is inserted	Tape/Radio selector switch or Reverse switch spring, faulty	Repair or replace
	Motor does not rotate due to fault	Replace motor
	Drive belt is cut or off	Replace or correct
	Mechanism does not operate for play	Check and repair See section 15 through 18
Distorted tape sound or low volume	Dirty head surface or deteriorated performance because of worn head	Clean the surface or replace head
Abnormal tape speed	Motor is faulty	Replace motor
	Drive belt is stretched	Replace belt
	Cassette tape is wound too tightly	Replace cassette tape to check
	Mechanism for running tape is faulty	Check drive system, nylon gear, etc.
Wow and flutter	Eccentric rotating shaft of motor (including pulley)	Replace motor
	Belt is stretched out to its full length	Replace belt
	Motor pulley, capstan shaft and pinch roller are dirty	Clean
No auto reverse at the end of tape playback	Tape is cut at end leader	Tape is ejected and unit is switched to radio (for units with radio and with radio OFF)
	Fault in end detector, detecting link, carriage ass'y, detecting cam shaft drive gear	Check and repair mechanism See Items 15 ~ 18
Auto reverse is normal, but program cannot be changed	Faulty program selector lock arm	Replace
FF or REW does not operate	Faulty FR reverse lever (A) ass'y	Check or replace parts concerned
	Fault in FR idler lever (A) ass'y or incorporated gear	Check or replace parts concerned
	Fault in FR idler lever (B) ass'y or gear in this ass'y	Check or replace parts concerned

# HOW TO REPLACE MAJOR PARTS (1)

# 11

See exploded views shown in Sections 14 and 15 for replacement of parts not described here and those which compose the assemblies.

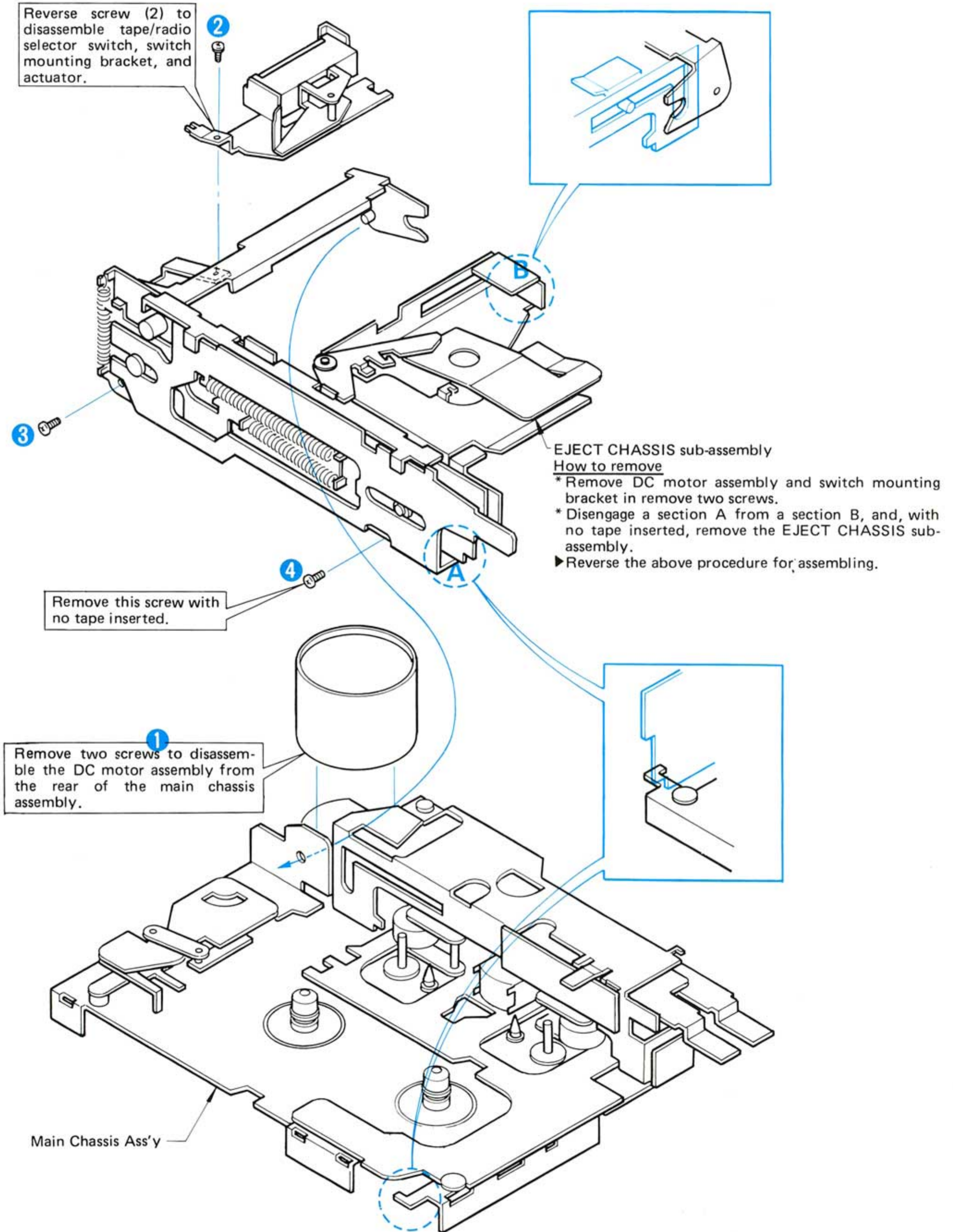

12

HOW TO REPLACE MAJOR PARTS (2)

See exploded views shown in Sections 14 and 15 for replacement of parts not described here and those which compose the assemblies.

EJECT LEVER

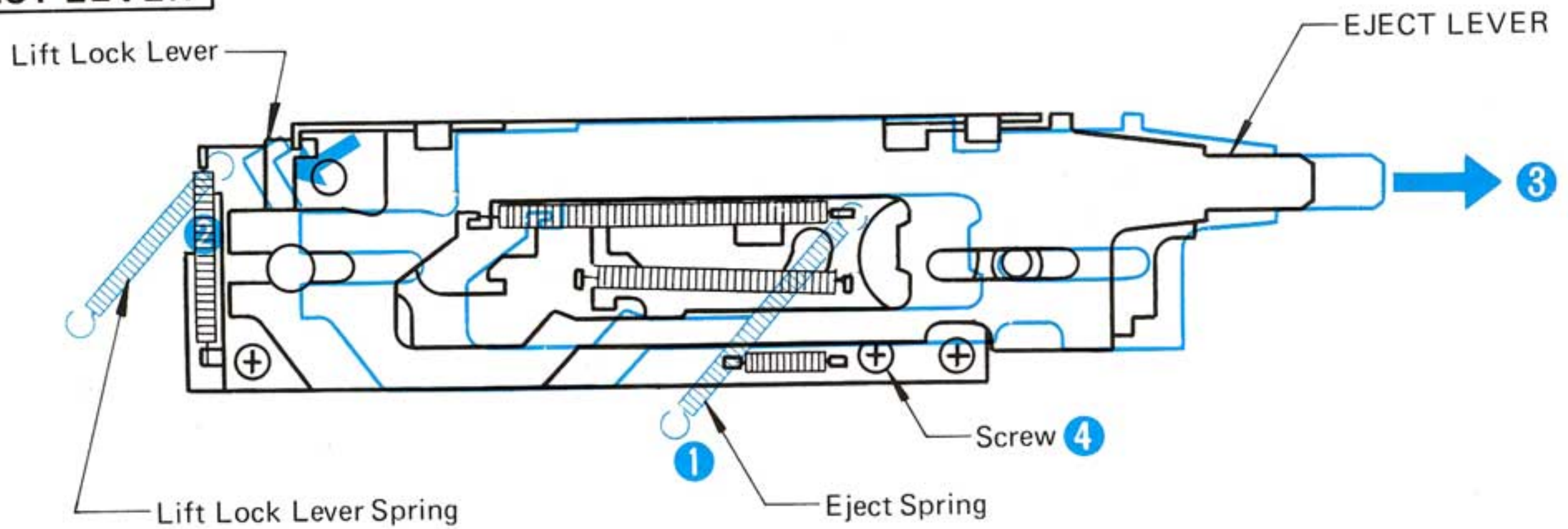

How to remove EJECT LEVER

Procedure

1. Remove eject spring.
2. Remove lift lock lever spring and shift lift lock lever in direction of arrow mark (←).
3. Pull eject lever in the direction of the arrow (→) until it stops. Eject lever can be disassembled from the EJECT CHASSIS sub-assembly on the opposite side (2) in the figure above.
  - After removal of eject lever, remove screw 4 to disassemble eject chassis sub-assembly.

How to disassemble FR chassis sub-assembly

Remove screws 1 and 2 to disassemble FR chassis sub-assembly.

- Push selector lock arm slightly in the direction of arrow (→) to incorporate FR chassis sub-assembly in an original position.

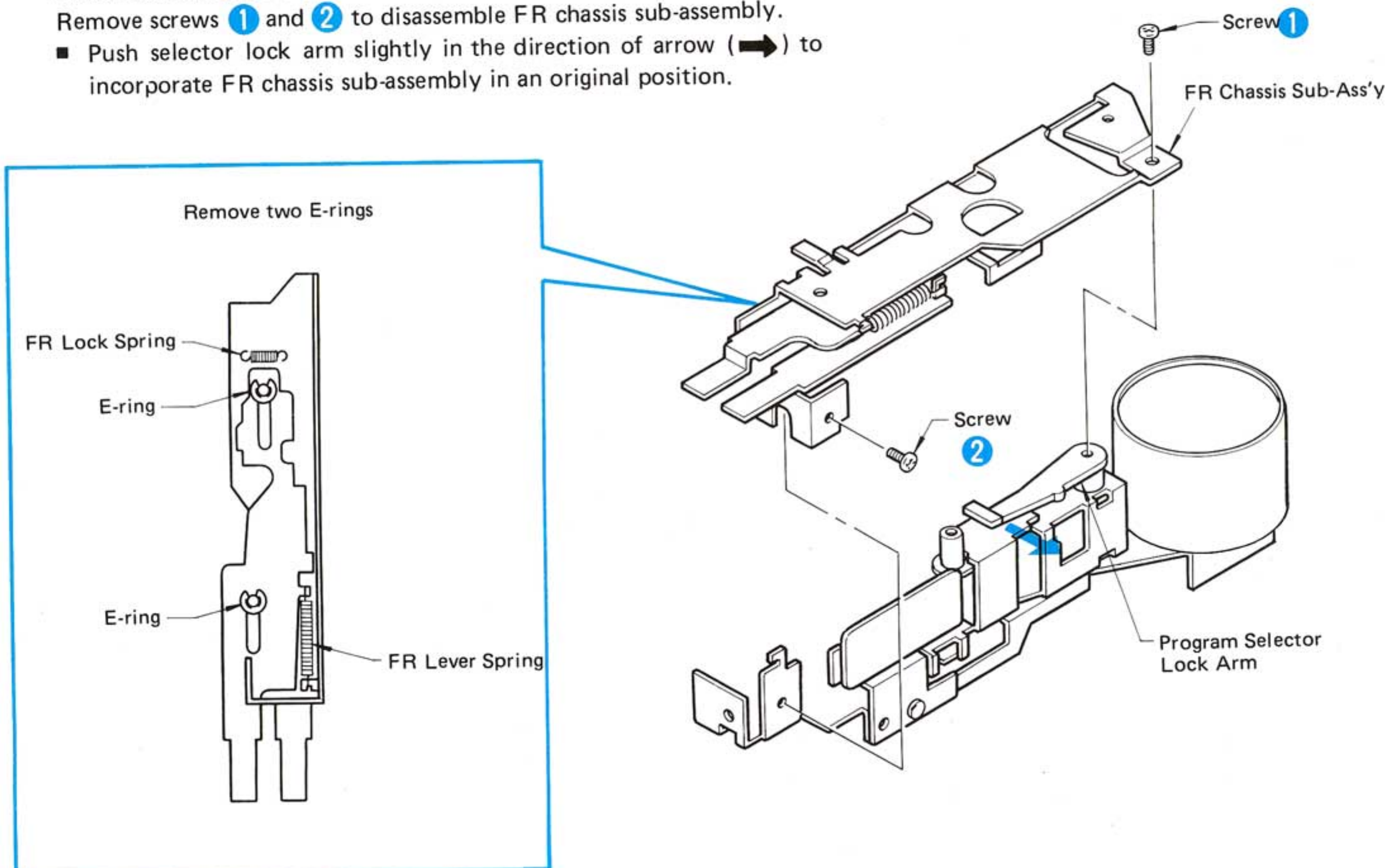



**HOW TO REPLACE MAJOR PARTS (3)**

**13**

See exploded views shown in Sections 14 and 15 for replacement of parts not described here and those which compose the assemblies.

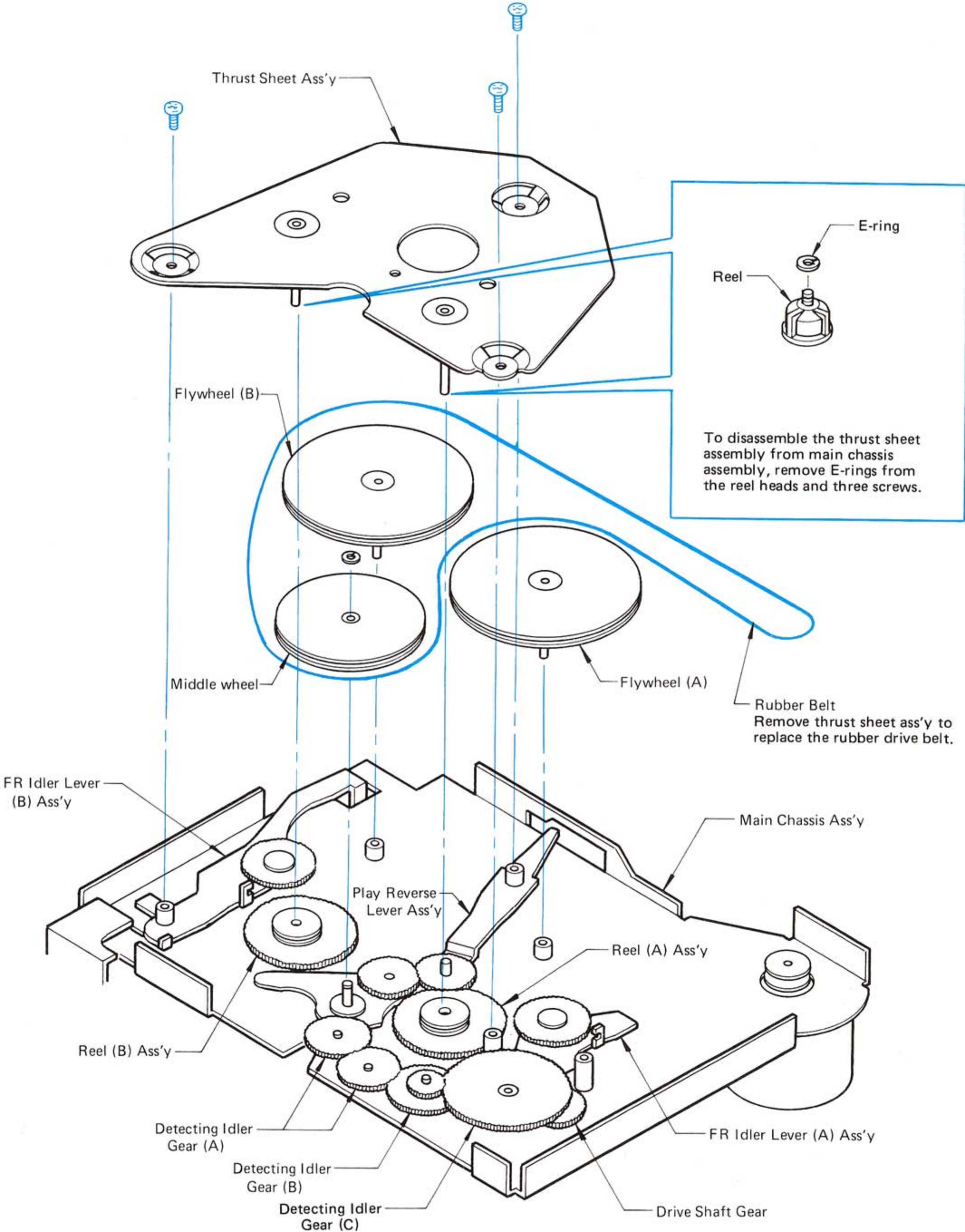

14

EXPLODED VIEW & PARTS LIST  
UPPER PORTION

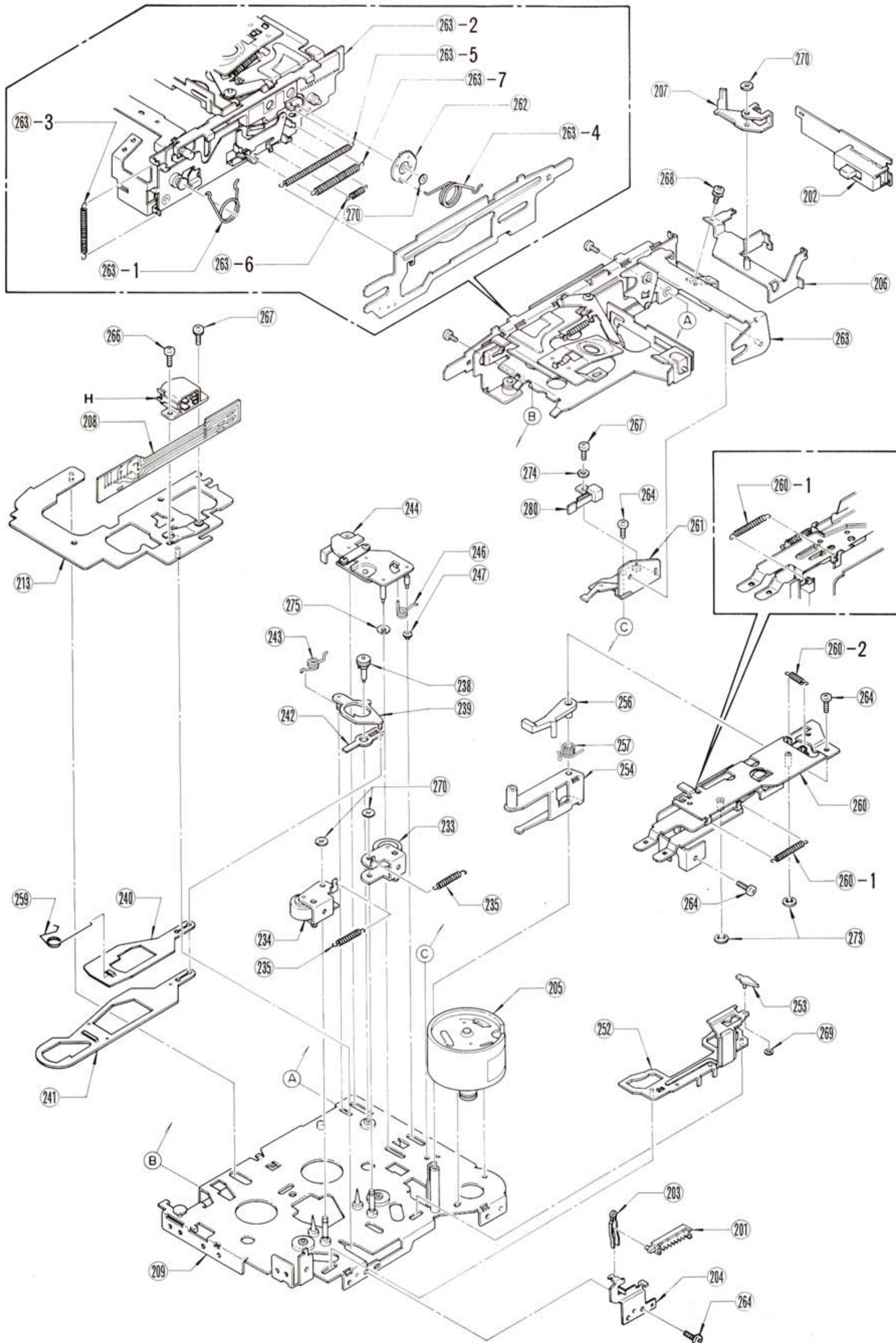

Note\* The part Nos. of this parts list should not be used for replacement parts.  
Refer to the service manual of each model for ordering parts.

Ref. No.	Part No. (general)	Part Name	Pcs Set	Ref. No.	Part No. (general)	Part Name	Pcs Set
H	YEAHHG442839	Playback Head	1	M263-3	YEFX005520	Lift Rack Lever Spring	1
M201	TEAS96199	Reverse Switch	1	M263-4	YEFX005518A	Reverse Gear Spring	1
M202	YEAS07041	Tape/Radio Selector Switch	1	M263-5	YEFX005524	Eject Spring	1
M280	YEAS23125	Muting Switch	1	M263-6	YEFX005525	Traction Spring	1
M203	YEFX005510	Spring	1	M263-7	YEFX005526B	Return Spring	1
M204	YEFX021933	Mounting Bracket, Switch	1	M264	XSB26 + 5FXS	ⓂScrew, Bind 2.6mm $\phi$ x 5mm	
M205	YESAK01040	DC Motor Ass'y	1	M266	XYN2 + C6FX	ⓂScrew w/Washer, 2mm $\phi$ x 6mm	
M206	YEFX021997	Mounting Bracket, Switch	1	M267	XSB2 + 6FX	ⓂScrew, Bind 2mm $\phi$ x 6mm	
M207	YEFX013010A	Actuator	1	M269	YEFX014007	Snap Ring	
M208	YEAP906A	Flexible PCB(No Resistor/Capacitor)	1	M270	YEFX014008	Snap Ring	
M209	YEFA01420D	Main Chassis Ass'y	1	M273	YEJE01004	E-Ring	
M213	YEFA01417A	Head Chassis Ass'y	1	M274	XWE2FX	Washer, Flat 2mm $\phi$	1
M233	YEFX218172C	Pinch Roller (A) Ass'y	1	M275	YEFX014014	Snap Ring	1
M234	YEFX218173C	Pinch Roller (B) Ass'y	1				
M235	YEFX005521	Pinch Roller Pressure Spring	2				
M238	YEFW06581	Detecting Shaft Ass'y	1				
M239	YEFX234129	Detection Cam	1				
M240	YEFX019014B	Detection Link (A)	1				
M241	YEFX019015A	Detecting Link (B)	1				
M242	YEFX046345	Trigger Lever	1				
M243	YEFX005516	Detecting Cam Return Spring	2				
M244	YEP0FX138B	Carriage Ass'y	1				
M246	YEFX005517	Rack Lever Spring	1				
M247	YEFX218167A	Carriage Roller	2				
M252	YEFX233139A	Pinch Roller Selector Plate Ass'y	1				
M253	YEFX234130	Program Selector Release Cam	1				
M254	YEP0FX139	FR Head Escape Arm Ass'y	1				
M256	YEFX249189	Program Selector Release Cam	1				
M257	YEFX005514	Program Lock Spring	1				
M259	YEFX005580	Spring	1				
M260	YEP0FX160B	FR Chassis Sub-Ass'y	1				
M260-1	YEFX005529	FR Lever Spring	2				
M260-2	YEFX005530	FR Lock Spring	1				
M261	YEFX0211078A	Reverse Gear	1				
M262	YEFX003114A	Reverse Gear	1				
M263	YEP0FX141A	Eject Chassis Sub-Ass'y	1				
M263-1	YEFX005523	Cassette Lift Spring	1				
M263-2	YEFX233138B	Rack Ass'y	1				

15

EXPLODED VIEW & PARTS LIST  
LOWER PORTION

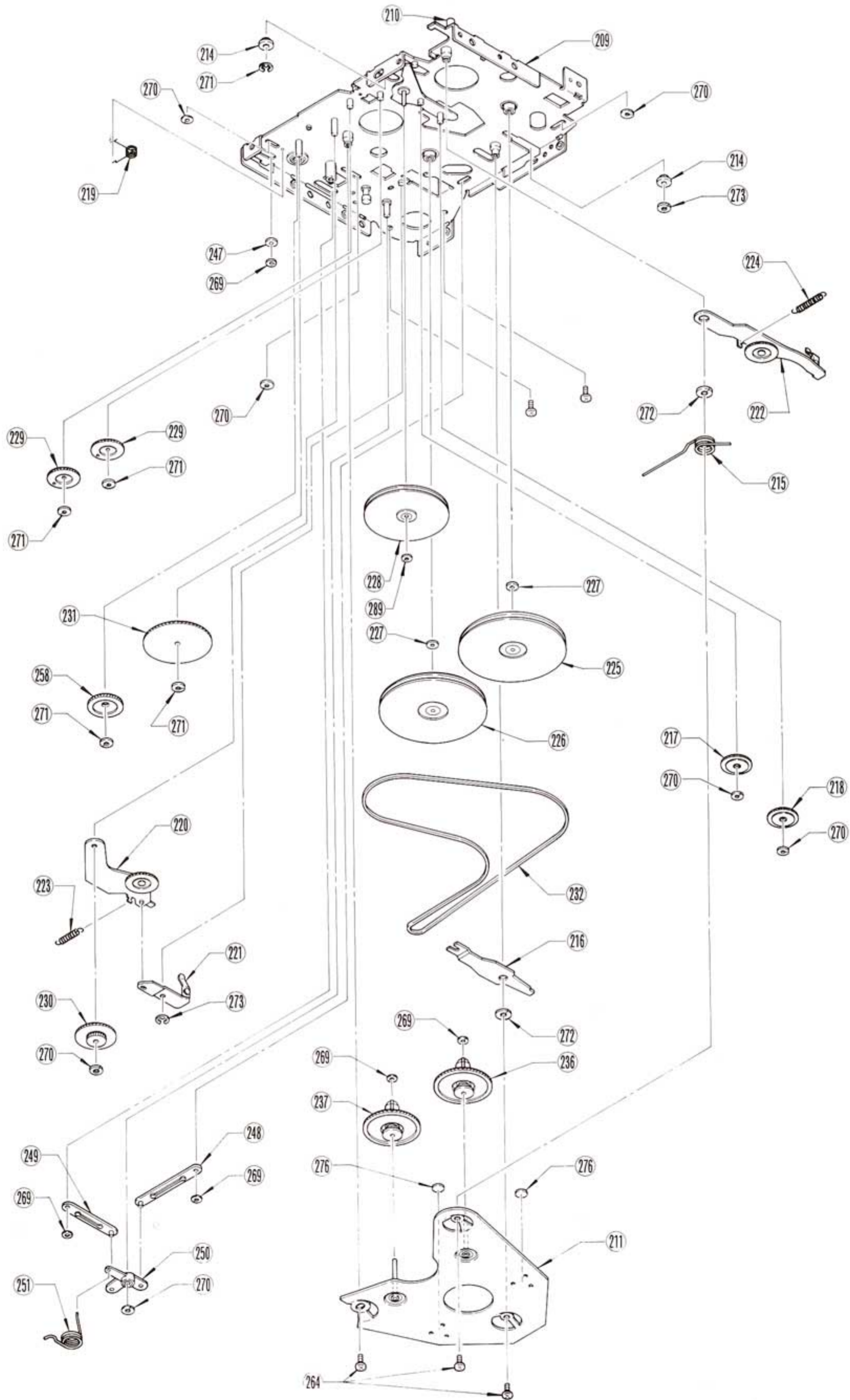

Note\* The part Nos. of this parts list should not be used for replacement parts.  
Refer to the service manual of each model for ordering parts.

Ref. No.	Part No. (general)	Part Name	Pcs Set
M210	YEFW7071	Stud	1
M211	YEFX219112	Thrust Sheet Ass'y	1
M214	YEFX218168A	Head Chassis Guide Roller	2
M215	YEFX005522	Head Chassis Spring	1
M216	YEFW06576	Play Reverse Lever Ass'y	1
M217	YEFX003111A	Play Idler Gear	1
M218	YEFX003116A	Play Idler Gear (B) Ass'y	1
M219	YEFX005519	Idler Lever Pressure Spring	1
M220	YEFW065784	FR Idler Lever (A) Ass'y	1
M221	YEFW6579	FR Reverse Lever (A) Ass'y	1
M222	YEFW06580B	FR Idler Lever (B) Ass'y	1
M223	YEFX005527	FR Idler Lever (A) Spring	1
M224	YEFX005528A	FR Idler Lever (B) Spring	1
M225	YEFX213141A	Flywheel (A)	1
M226	YEFX213146A	Flywheel (B)	1
M227	YEJW02091A	Wahser, Flat	2
M228	YEFX213143	Middle Wheel	1
M229	YEFX003108	Detecting Idler Gear (A)	2
M230	YEFX003109	Detecting Idler Gear (B)	1
M231	YEFX003110	Detecting Idler Gear (C)	1
M232	YEFR03035	Rubber Belt	1
M236	YEFX209149C	Reel (A) Ass'y	1
M237	YEFX209150C	Reel (B) Ass'y	1
M248	YEFX019016	Joint Plate (A)	1
M249	YEFX019017	Joint Plate (B)	1
M250	YEFX019012	Tri-Link	1
M251	YEFX005515A	Tri-Link Spring	1
M258	YEFX003113	Drive Shaft Gear	1
M264	XSB26 + 5FXS	⊕Screw, Bind 2.6mm $\phi$ x 5mm	
M268	XYN2 + C4FX	⊕Screw w/Washer, 2mm $\phi$ x 4mm	2
M269	YEFX014007	Snap Ring	
M270	YEFX014008	Snap Ring	
M271	YEFX014010	Snap Ring	
M272	YEFX014013A	Snap Ring	
M273	YEJE01004	E-Ring	
M276	YEFX219108	Thrust Sheet	
M277	XSB26 + 4FXR	⊕Screw, Bind 2.6mm $\phi$ x 4mm	



# MEMO