

Service Manual

Cassette Tape Deck RS-671US

High Fidelity Cassette Tape Deck with Front Loading & Controls, Dolby* Noise Reduction, HPF Head



RS-676US MECHANISM SERIES

Specifications (Catalog specifications for sales)

Power requirement:	AC; 120V, 50/60Hz Power consumption; 20W	Signal to noise ratio:	Dolby NR out; 52dB (signal level=250pwb/mm)
Motor:	2-motor system 1-electronic speed control motor for capstan drive 1-DC motor for reel table drive	Input:	Dolby NR in; 60dB at 5kHz MIC; sensitivity 0.3mV/applicable microphone impedance 600Ω~20KΩ
Track system:	4-track 2-channel stereo recording and playback	Output:	LINE; sensitivity 60mV/68KΩ LINE; output level 0.42V (at 0 VU)/ load impedance 50KΩ over HEADPHONE; output level 65mV (at 0 VU)/8Ω
Recording system:	AC bias (85kHz), AC erase	Head:	1-HPF head for record/playback 1-Ferrite head for erase
Tape speed:	1-7/8ips.	Rewind time:	Approx. 90 seconds with C-60 cassette tape
Program time:	1 hour stereo recording with C-60 cassette tape	Dimensions:	16-3/8"(W)×5-1/2"(H)×13"(D)
Wow and flutter:	0.075% (WRMS), ±0.15% (DIN)	Weight:	20-5/8lbs.
Frequency response:	CrO ₂ tape; 30~17,000Hz Normal tape; 30~15,000Hz		

The above specifications show the numerical value measured with our standard tape conforming to the IEC standard. Specifications are subject to change without notice for further improvement.

Technics
by Panasonic

Matsushita Electric Corp. of America
1 Panasonic Way, Secaucus, N.J. 07094

Matsushita Electric of Hawaii, Inc.
320 Waiala Road, Honolulu, Hawaii 96817

LOCATION OF CONTROLS AND COMPONENTS

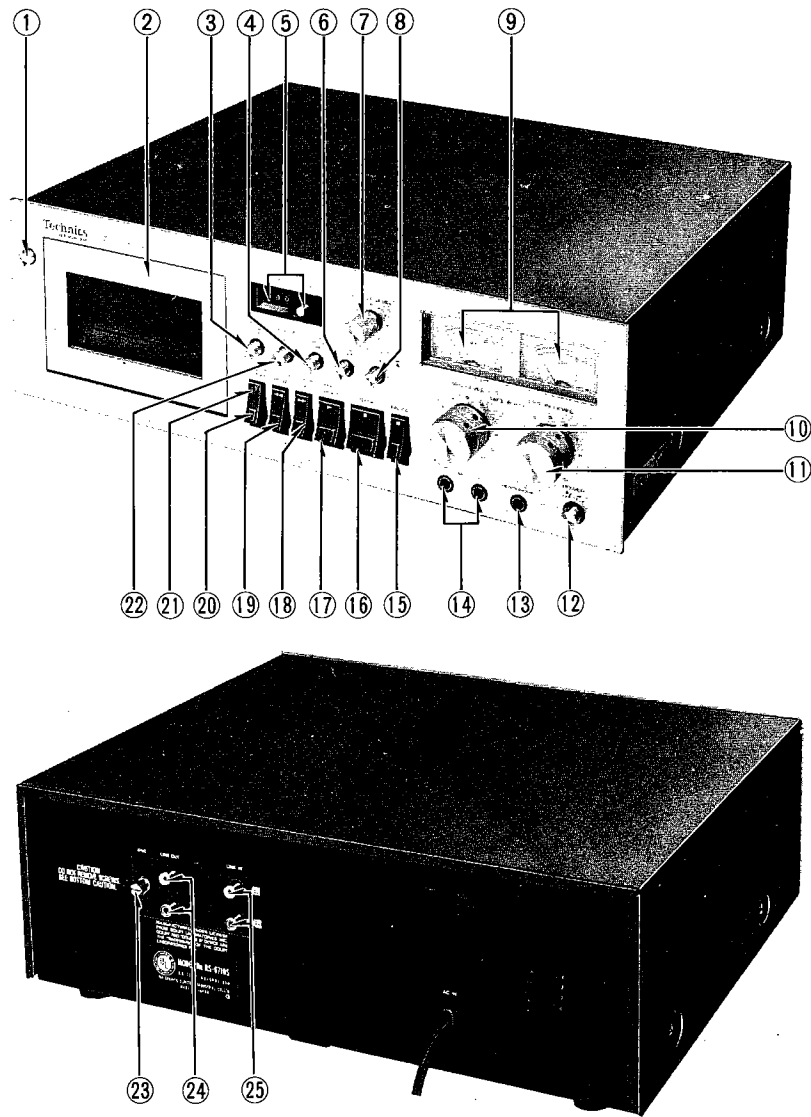
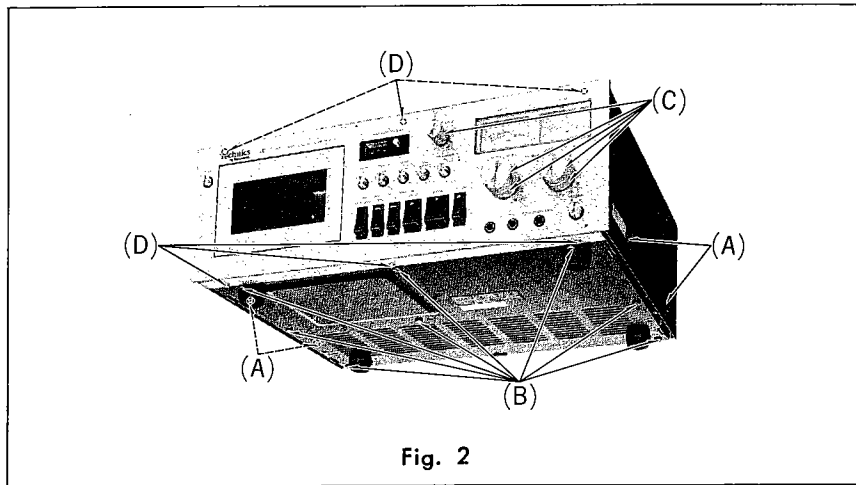

Fig. 1

- | | |
|---------------------------------|--------------------------------|
| ① Ejection button | ⑭ Microphone jacks |
| ② Cassette cover | ⑮ Pause button |
| ③ Memory-rewind switch | ⑯ Stop button |
| ④ Bias selector | ⑰ Playback button |
| ⑤ Tape counter and reset button | ⑱ Fast forward button |
| ⑥ Equalization selector | ⑲ Rewind button |
| ⑦ Output level control | ⑳ Record button |
| ⑧ Peak-signal check button | ㉑ Recording indication lamp |
| ⑨ VU meters | ㉒ Dolby noise-reduction switch |
| ⑩ Microphone level control | ㉓ Ground terminal |
| ⑪ Line input level control | ㉔ Line output jacks |
| ⑫ Power switch | ㉕ Line input jacks |
| ⑬ Headphones jack | |

DISASSEMBLY INSTRUCTIONS

HOW TO REMOVE CASE COVER, BOTTOM PANEL AND FRONT PANEL



Procedure	How to remove—	Remove—	Pcs.	Remarks
1	Case cover	(A)	(4)	A: Black screws
2	Bottom panel	(B)	(8)	B: Red screws
3	Front panel	(C), (D)	(5), (6)	

HOW TO REMOVE FRONT ANGLE AND CASSETTE COVER

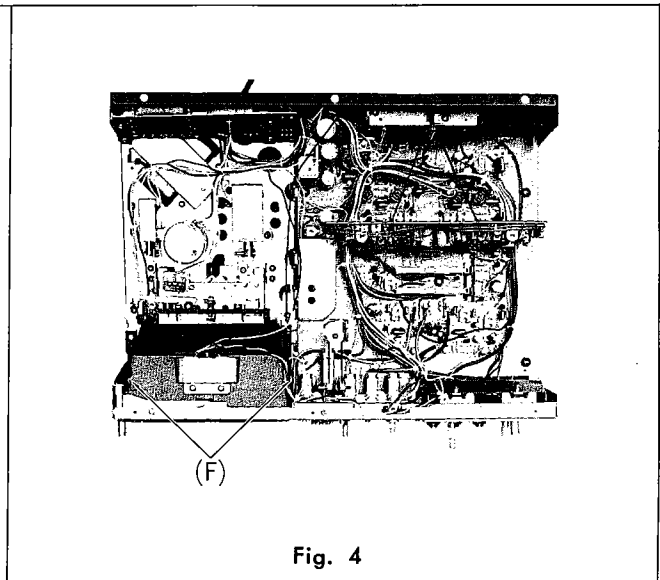
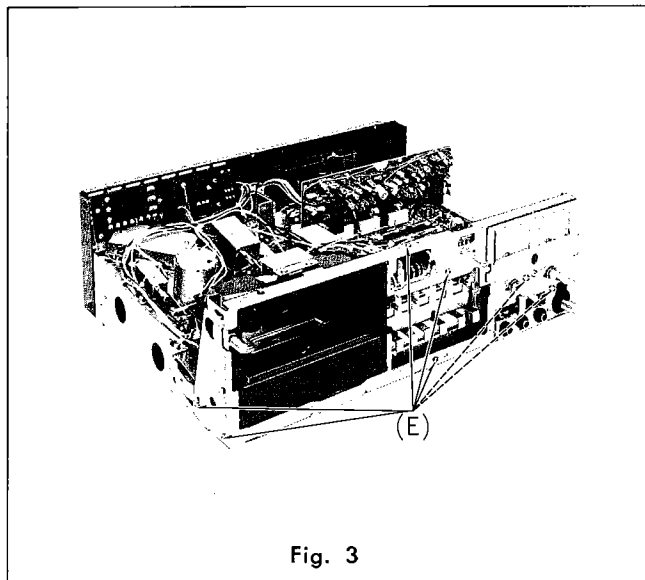

Procedure	How to remove—	Remove—	Pcs.	Remarks
1	Front angle	(E)	(7)	E: Red screws
2	Cassette cover	(F)	(2)	

HOW TO REMOVE JACK BASE PLATE AND PRINTED CIRCUIT BOARD (AMP & CONTROL)

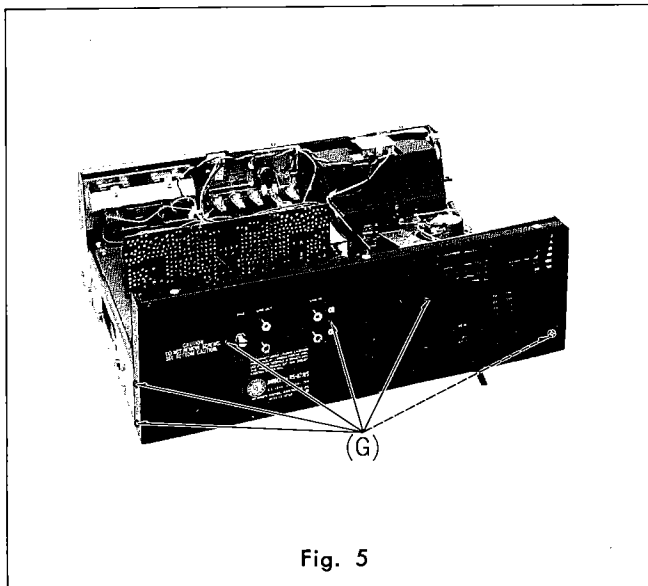

Fig. 5

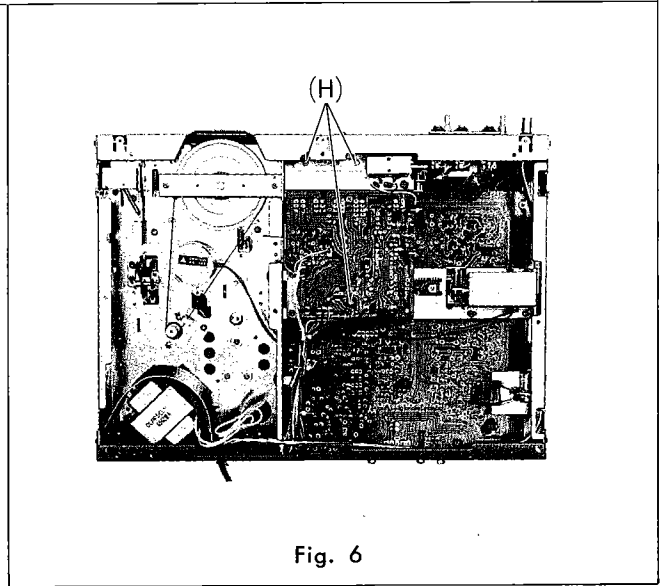

Fig. 6

Procedure	How to remove—	Remove—	Pcs.	Remarks
1	Jack base plate	(G)	(6)	G: Black screw
2	Printed circuit board (CONTROL)	(H)	(3)	

HOW TO REMOVE HEAD COVER

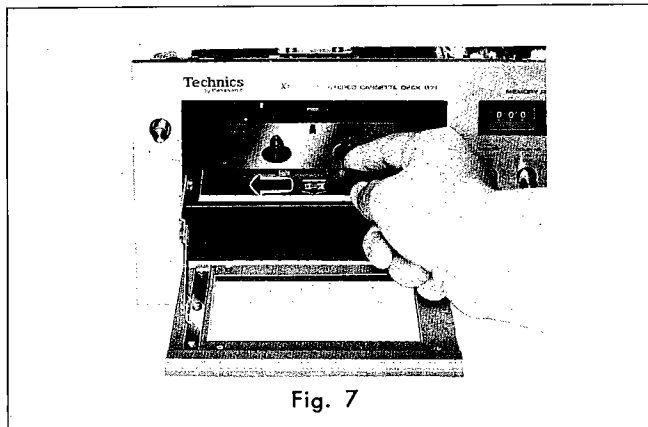

Fig. 7

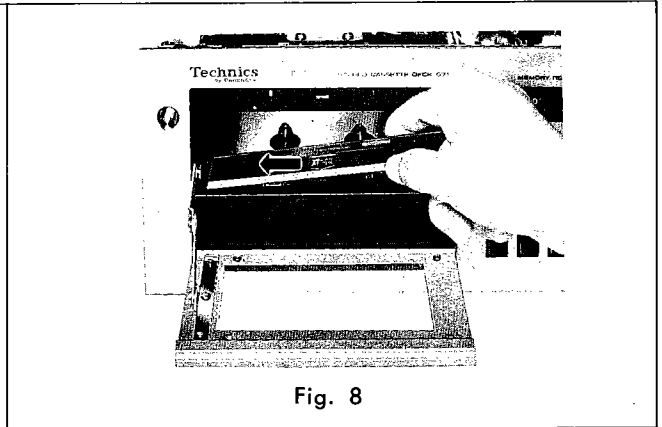

Fig. 8

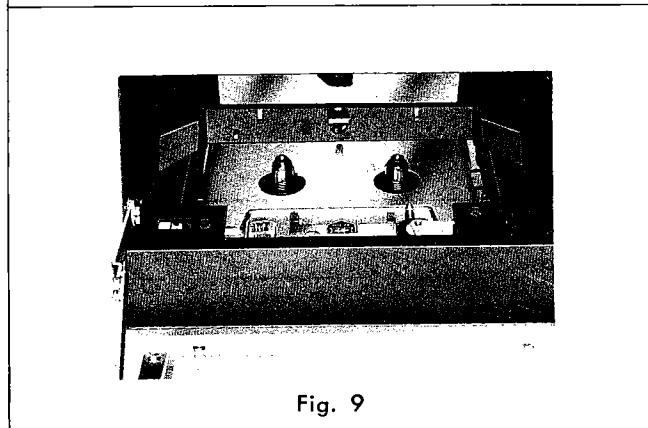

Fig. 9

1. Pushing the head cover as shown in fig. 7, and lift it up as shown in fig. 8.
2. Then head cover can be removed.

ADJUSTMENTS

Before measuring and adjusting "Overall Frequency Response", "Overall Distortion" and "Overall S/N Ratio", confirm that the characteristics of 5 items below are within standard which have much relation to or influence on electrical performances above.

1. Head Azimuth Adjustment
2. Bias current
3. Playback Gain
4. Overall Gain
5. Playback Frequency Response

I. TEST INSTRUMENTS

1. Prepare test instruments which are equivalent in accuracy to those shown below.
2. The test instruments should be inspected and corrected by specialists once every 6 months, because a long period of use without maintenance may increase errors in indication.
3. Warm up the test instruments for 30 minutes and the set to be measured for 10 minutes before taking the measurements. If not, there may arise an error or difference between the initial value and the stabilized value measured after "aging".
4. Specifications of Test Instruments.

(1) Audio Frequency Oscillator

- a. Oscillation Frequency: 5 Hz~500 kHz (5 ranges)
- b. Frequency Tolerance: $\pm(3\%+1\text{ Hz})$
- c. Sine Wave
 - * Output Voltage: 5 Vrms $\pm 10\%$ (without load)
2.5 Vrms $\pm 10\%$ (with 600 Ω load)
(at 25°C)
 - * Output Frequency Response:
 - Within ± 0.2 dB, 20 Hz~20 kHz
 - Within ± 0.5 dB, 5 Hz~500 kHz
 - * Distortion Factor: Not more than 0.05%, 200 Hz~20 kHz
Not more than 0.5%, 5 Hz~500 kHz
 - * Output Impedance: 600 Ω unbalanced, Within $\pm 15\%$
 - * Output Attenuator: 0, 20 dB, Error: Within ± 0.2 dB
- d. Temperature in Use of Set: Temperature=0~40°C: Humidity=90% or less

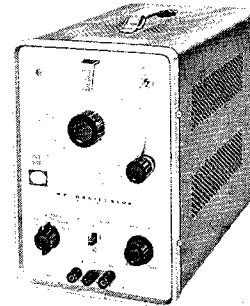

(2) Automatic-stop Distortion Meter (with Vacuum Tube Voltmeter)

- A. Distortion Factor Measurement
 - a. Frequency (Fundamental wave): 400 Hz, 1 kHz $\pm 10\%$
 - b. Measurement: 0.1%~100% (6 range)
 - c. Input: 50 mV~50 V
 - d. Fundamental Wave Attenuation: 60 dB or more
- B. Level Measurements
 - a. Measurement: 1 mV (-60 dB)~30 V (30 dB) 9 range
 - b. Frequency Response (1 kHz basis): 20 Hz~100 kHz ± 0.3 dB
 - c. Input Impedance: 1 M Ω $\pm 10\%$, Less than 50 pF
 - d. Error in Indicated Value: Within $\pm 3\%$ at 1 kHz
- C. Output Terminal
 - a. Frequency Response: 10 Hz~100 kHz ± 1 dB
100 kHz~1 MHz ± 3 dB
 - b. Output Voltage: 1 Vrms $\pm 10\%$ (1 kHz sine wave)



(3) Attenuator

- a. Input Impedance: 600Ω unbalanced
- b. Maximum Attenuation: 121 dB
- c. Minimum Attenuation: 0.1 dB

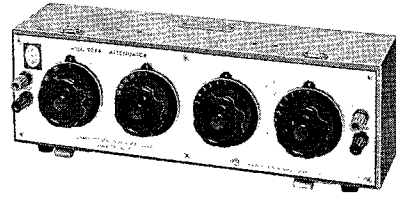

(4) Oscilloscope

- a. Cathode Ray Tube: Effective range 8 × 8 cm
- b. Vertical Axis
 - * Input Sensitivity: 30 mV~30 V/cm
 - * Frequency Band: DC~2 MHz
 - * Transient Time: 180 ns.
 - * Input Impedance: 1 MΩ, 35 pF
- c. Horizontal Axis
 - * Tuning Range: 30 Hz~2 MHz
 - * Sweep Time: 1μs~100 ms/cm
 - * External Sweep: 1 Vp-p/cm or more

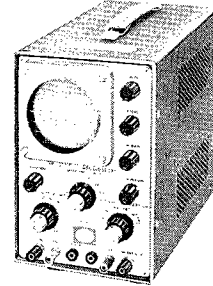

(5) Digital Electronic Counter

- a. Number of Figures: 4 (decimal system)
- b. Input Sensitivity: 100 mV rms
- c. Input Impedance: 1 MΩ, 40 pF
- d. Frequency Measurement Range: 10 Hz~100 kHz
- e. Counting Time: 0.1, 1, 10 s

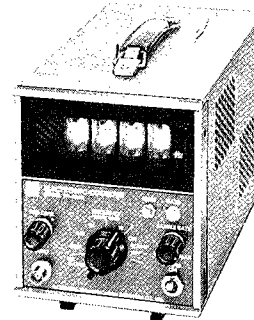

(6) Wow Meter

- a. Measured Center Frequency Range: 3 kHz±4%
- b. Input Level Range: 30 mV~3 V
- c. Input Impedance: About 50 KΩ unbalanced
- d. Measurement: 0.01~3% (5 ranges)
- e. Indicator Error: Maximum error in indicated value±5% in each range.
- f. Frequency Response: Conforming to weighting curve characteristic (WRMS), JIS C5551.
Flat characteristic (RMS)
0.5~200 Hz, Within -3 dB (4 Hz basis)
- g. Meter Indication System: Effective value indication, conforming to JIS C5551.
- h. Meter Response Characteristic: About 5~7 sec.
- i. Oscillation Frequency: 3 frequencies (3 kHz, 3 kHz±3%)
- j. Temperature Range: 0~40°C

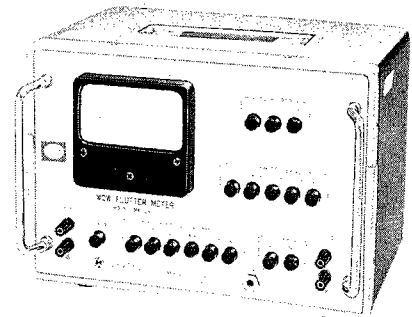

II. MEASUREMENT CONDITIONS

1. Standard Measurement Conditions
 - * Ambient Temperature: 10°~30°C (50°~86°F)
 - * Ambient Humidity: 30~90% RH
 - * Power Voltage Accuracy: ±3%
2. Position of Tape Recorder

When measuring, place the unit under test in a horizontal position.
3. Oscillator Output Voltage Adjustment
 - * Connect the equipments sa shown in the following and adjust the oscillator output control knob for 1 V (f=1 kHz) through the attenuator while keeping the attenuator at 0 dB.
 - * When supplying a signal to the tape recorder amplifier, adjust the input level using the attenuator.

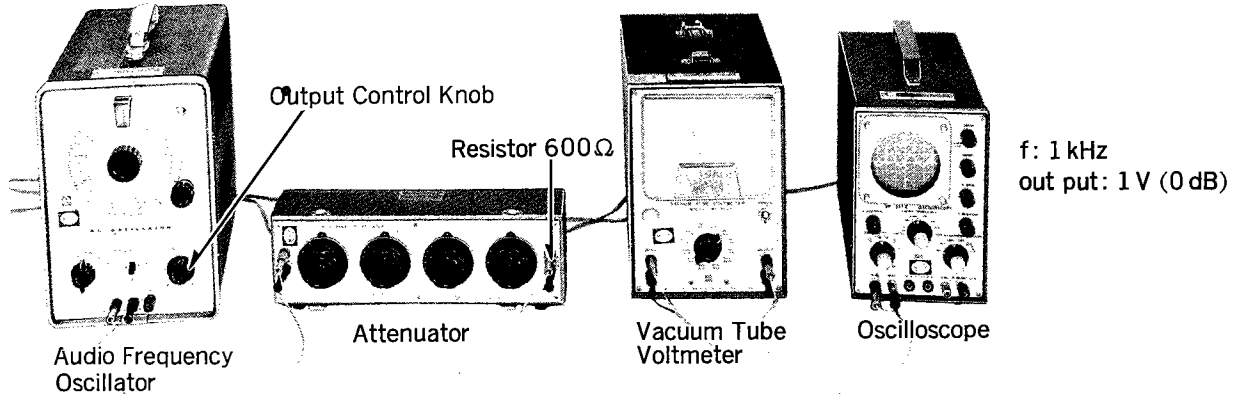

III. TEST TAPE

* Test Tape Life

The more frequently the test tape is used, the more the tape characteristics will deteriorate (e.g. lowering of recorded level, worsening of frequency response particularly in high-frequency range, and an increase in wow due to tape elongation) until measured values become unreliable. Even in such a case when a tape is not used, but stored, for a long period of time, tape shows deterioration in performance because of self-damage due to storage conditions, etc.

Please refer to the tape life specification and use care not to use a tape longer than its rated life when servicing.

Frequency of Use: Not more than 20 times for each tape length.

Storage Period: Not more than 6 months.

※ Test Tape

PARTS NO.	PARTS NAME	SPECIFICATIONS	REMARKS
C-FH	STANDARD REC. LEVEL & FREQ. RESPONSE TAPE		5 TIMES REPETITIVE RECORDING TAPE SPEED: 1-7/8 IPS (4.8 cm/S), FULL TRACK (10 MIN.)
C-WAT	WOW & TAPE SPEED TAPE		TAPE SPEED: 1-7/8 IPS (4.8 cm/S), FULL TRACK (45 MIN.)
C-AA	AZIMUTH TAPE		TAPE SPEED: 1-7/8 IPS (4.8 cm/S), FULL TRACK (15 MIN.)
C-RA	REFERENCE BLANK TAPE NORMAL		UNRECORDED TAPE (20 MIN.)
C-RF	REFERENCE BLANK TAPE CrO ₂		UNRECORDED TAPE (20 MIN.)

IV. MEASUREMENT & ADJUSTMENT METHOD

NOTE:

- | | |
|--|---|
| <ol style="list-style-type: none"> 1. Make sure heads are clean. 2. Make sure capstan and pressure roller are clean. 3. Judgeable room temperature: $20 \pm 5^\circ\text{C}$ ($68 \pm 9^\circ\text{F}$) 4. Memory switch: OFF 5. Dolby NR switch: OUT | <ol style="list-style-type: none"> 6. Bias selector: LOW 7. Equalizer selector: $120\mu\text{S}$ 8. Peak check switch: OUT 9. Output level control: MAX. |
|--|---|

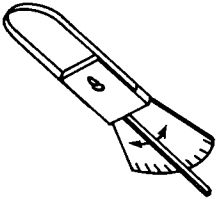
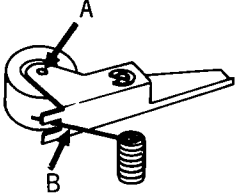
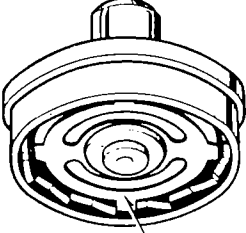
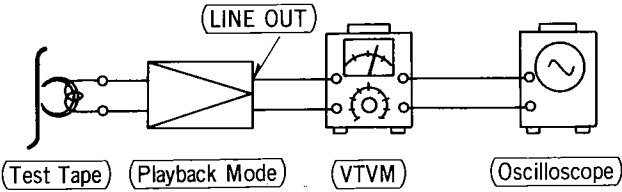
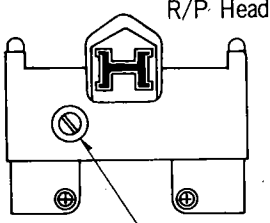
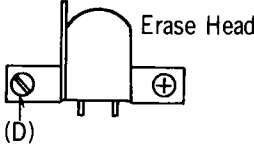
ITEM	MEASUREMENT & ADJUSTMENT	REMARKS
<p>Pressure of Pressure Roller Equipment: * Tension Gauge (max. 500 gr)</p> 	<ol style="list-style-type: none"> 1. Place UNIT into playback mode. 2. Hook tension gauge to pressure roller shaft top (A), and pull gauge in direction opposite to pressure of pressure roller against capstan (See fig. 10). 3. Read pressure indicated on gauge immediately when pressure roller moves away from capstan and stops rotating. <div style="border: 1px solid black; padding: 2px; width: fit-content; margin: 10px auto;">Standard Value: 400 ± 50 gr</div> <p>Adjustment method Adjust by bending the (B) part of the pressure roller spring (See fig. 10).</p>	<p>* Playback Mode</p>  <p style="text-align: center;">Fig. 10</p>
<p>Takeup Tension Equipment: * Cassette Torque Meter (SRK-CT or RP8063)</p>	<ol style="list-style-type: none"> 1. Mount cassette torque meter on UNIT. 2. Place UNIT into playback mode and read takeup torque. 3. Measure several times and determine the mean value. <div style="border: 1px solid black; padding: 2px; width: fit-content; margin: 10px auto;">Standard Value: 55 ± 15 gr-cm</div> <p>If the measured value is not within standard, firstly clean the rotational parts of the mechanism with alcohol, and if it still is not within standard, make the following adjustment.</p> <p>Adjustment method Adjust by turning the plate spring attached in the takeup reel table (See fig. 11).</p>	<p>* Playback Mode</p>  <div style="border: 1px solid black; padding: 2px; width: fit-content; margin: 10px auto;">Plate Spring</div> <p style="text-align: center;">Fig. 11</p>
<p>Head Azimuth Adjustment Equipment: * VTVM * Oscilloscope * Test Tape (Azimuth) ...C-AA * Tape Path Viewer ...RT-8133</p>	<p>Record/playback head adjustment</p> <ol style="list-style-type: none"> 1. Test equipment connection is shown below. <div style="text-align: center;">  <p style="text-align: center;">Fig. 12</p> </div> <ol style="list-style-type: none"> 2. Play azimuth tape (C-AA 6.3 kHz). 3. Adjust record/playback head angle adjustment screw (C) in fig. 13 so that output level at LINE OUT becomes maximum. 4. Measure both channels, and adjust levels for equal output. 5. After adjustment lock head adjustment screw with lacquer. <p>Erase head adjustment</p> <ol style="list-style-type: none"> 1. Test equipments connection is the same above but use the tape path viewer (RT-8133) instead of test tape (C-AA). 2. Play this tape. 3. Adjust screw (D) shown in fig. 14 so that the tape may not get curled or malformed by tape guide of the erase head. 4. After adjustment lock head adjust screw with lacquer. 	<p>* Playback Mode</p> <div style="text-align: center;">  <p style="text-align: center;">R/P Head</p> <p style="text-align: center;">(C)</p> <p style="text-align: center;">Fig. 13</p>  <p style="text-align: center;">Erase Head</p> <p style="text-align: center;">(D)</p> <p style="text-align: center;">Fig. 14</p> </div>

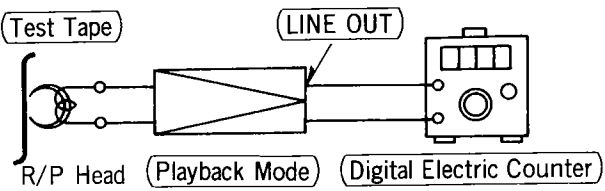
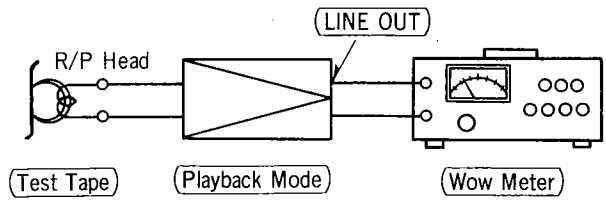
ITEM	MEASUREMENT & ADJUSTMENT	REMARKS
<p>Tape Speed</p> <p>Equipment:</p> <ul style="list-style-type: none"> * Digital Electronic Counter or Frequency Counter (RP-8067) * Test Tape...C-WAT 	<p>Tape speed accuracy</p> <p>1. Test equipment connection is shown below.</p> <div style="text-align: center;">  </div> <p style="text-align: center;">Fig. 15</p> <p>2. Play test tape (C-WAT 3,000 Hz), and supply playback signal to frequency counter.</p> <p>3. Measure this frequency.</p> <p>4. On the basis of 3,000 Hz, determine value by following formula:</p> $\text{Tape speed accuracy} = \left(\frac{f - 3,000}{3,000} \times 100 \right) \%$ <p style="text-align: center;">where, f = measured value</p> <p>5. Take measurement at middle section of tape.</p> <div style="text-align: center; border: 1px solid black; padding: 5px; width: fit-content; margin: 0 auto;"> Standard Value: ±1.5% </div> <p>Adjustment method</p> <ol style="list-style-type: none"> 1. Play the test tape (middle). 2. Adjust the tape speed adjustment VR shown on page 18 so that frequency becomes 3,000 Hz. <p>Tape speed fluctuation</p> <p>Make measurements in same manner as above (beginning, middle and end of tape), and determine difference between maximum and minimum values and calculate as follows:</p> $\text{Tape speed fluctuation} = \left(\frac{f_1 - f_2}{3,000} \times 100 \right) \%$ <p style="text-align: center;">f₁ = maximum value f₂ = minimum value</p> <div style="text-align: center; border: 1px solid black; padding: 5px; width: fit-content; margin: 0 auto;"> Standard Value: 0.5% </div>	<p>* Playback Mode</p>
<p>Wow and Flutter</p> <p>Equipment:</p> <ul style="list-style-type: none"> * Wow Meter * Test Tape...C-WAT 	<p>1. Test equipment connection is shown below.</p> <div style="text-align: center;">  </div> <p style="text-align: center;">Fig. 16</p> <p>2. Use wow test tape (3,000 Hz) and measure its playback signal on wow meter.</p> <p>3. Wow & Flutter is expressed in percentage and that measurement can be weighted by JIS Network. (WRMS)</p> <p>4. Measure at middle section of test tape.</p> <div style="text-align: center; border: 1px solid black; padding: 5px; width: fit-content; margin: 0 auto;"> Standard Value: 0.08% (WRMS) </div>	<p>* Playback Mode</p>

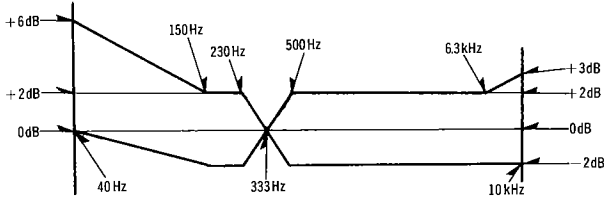
ITEM	MEASUREMENT & ADJUSTMENT	REMARKS
<p>Playback Frequency Response Equipment: * VTVM * Oscilloscope * Test Tape...C-FH</p>	<ol style="list-style-type: none"> 1. Test equipments connection is as same as "Head Azimuth Adjustment" but use the test tape (C-FH) instead of head azimuth tape (See fig. 12). 2. Place UNIT into playback mode. 3. Play frequency response test tape (C-FH). 4. Measure output level at 10kHz, 8kHz, 4kHz, 1kHz, 125Hz and 63 Hz and compare output level with standard frequency 333 Hz, at LINE OUT. 5. Make measurement for both channels. 6. Make sure that the measured value is within the range specified in the frequency response chart. <p style="text-align: center;">Playback Frequency Response Chart</p>  <p style="text-align: center;">Fig. 17</p> <ol style="list-style-type: none"> 7. If measured value is not in standard, adjust VR3 (L-CH), VR4 (R-CH) (See fig. 36 on page 18). 	<p>* Playback Mode</p>
<p>Playback Gain Equipment: * VTVM * Oscilloscope * Test Tape...C-FH</p>	<ol style="list-style-type: none"> 1. Test equipment connection is shown in fig 12. 2. Play standard recording level portion on test tape (C-FH 333 Hz) and, using VTVM, measure the output level at LINE OUT jack. 3. Make measurement for both channels. <div style="border: 1px solid black; padding: 5px; width: fit-content; margin: 10px auto;"> <p style="text-align: center;">Standard Value: 0.42 V (-7 dB)</p> </div> <p>Adjustment</p> <ol style="list-style-type: none"> 1. If measured value is not standard, adjust VR5 (L-CH), VR6 (R-CH) (See fig. 36 on page 18). 2. After adjustment, check "Playback Frequency Response" again. 	<p>* Playback Mode</p>
<p>Playback S/N Ratio Equipment: * VTVM * Oscilloscope * Test Tape...C-FH * Empty Cassette</p>	<ol style="list-style-type: none"> 1. Test equipment connection is shown in fig. 12. 2. Play standard recording level test tape (C-FH 333 Hz) and read output level on VTVM. Refer to "Playback Gain Adjustment". 3. Place empty cassette (which has been cut) and play again. 4. Measure noise level at this time using VTVM, and determine ratio of this level to test tape output signal voltage (333Hz). <div style="border: 1px solid black; padding: 5px; width: fit-content; margin: 10px auto;"> <p style="text-align: center;">Standard Value: Greater than 45 dB</p> </div> <p>An example calculation is shown below.</p> <p>A: Es= playback output signal voltage of test tape (333 Hz) B: En= playback output noise level</p> <p style="margin-left: 20px;">Es=0.42 V (-7 dB) En=2.5 mV (-52 dB)</p> $\text{S/N ratio} = \frac{E_s}{E_n} = \frac{0.42 \text{ V}}{2.5 \text{ mV}} = 178$ $20 \log_{10} 178 = 45 \text{ dB}$ <p style="margin-left: 20px;">S/N ratio=Es (dB) -En (dB) = -7 - (-52) = 45 dB</p>	<p>* Playback Mode</p>

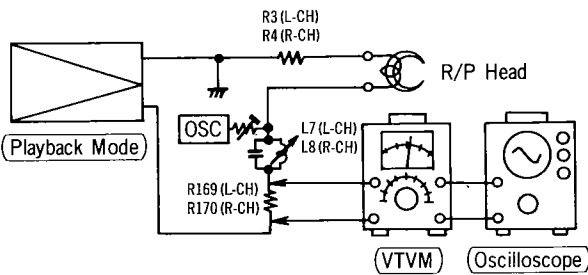
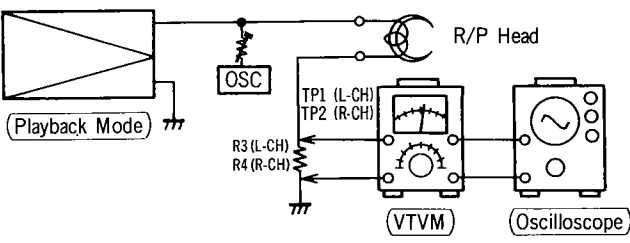
ITEM	MEASUREMENT & ADJUSTMENT	REMARKS
<p>Bias Leak</p> <p>Equipment:</p> <ul style="list-style-type: none"> * VTVM * Oscilloscope 	<ol style="list-style-type: none"> 1. Test equipment connection is shown below (See AMP circuit board on page 21).  <p style="text-align: center;">Fig. 18</p> <ol style="list-style-type: none"> 2. Place UNIT into record mode. 3. Adjust trap coils L7 (L-CH), L8 (R-CH), so that measured value become minimum (See adjustment parts location on page 18). 4. Make adjustment for both channels. 	<ul style="list-style-type: none"> * Record Mode * MIC and LINE IN Level Control...MAX
<p>Bias Current</p> <p>Equipment:</p> <ul style="list-style-type: none"> * VTVM * Oscilloscope 	<ol style="list-style-type: none"> 1. Test equipment connection is shown below.  <p style="text-align: center;">Fig. 19</p> <ol style="list-style-type: none"> 2. Place UNIT into record mode, and equalizer selector to 120μS, bias selector to LOW (for normal tape). 3. Read voltage on VTVM and calculate bias current by following formula. $\text{Bias current (A)} = \frac{\text{Value read on VTVM (V)}}{10 (\Omega)}$ <div style="border: 1px solid black; padding: 5px; width: fit-content; margin: 10px auto;"> <p style="text-align: center;">Standard Value: 0.17 ± 0.05 mA</p> </div> <ol style="list-style-type: none"> 4. Adjust VR301 (L-CH), and VR302 (R-CH) (See adjustment part location on page 18). 5. Then changing the equalizer selector to 70μS and bias selector to HIGH (for CrO₂ tape), confirm that bias current become greater by 25% than that for normal. 6. If measured value is not in standard, adjust VR303 become 0.21 mA. 	<ul style="list-style-type: none"> * Record Mode * Be sure the ground end of the meter is connected to the ground end of the resistor. * When bias current is adjusted on one channel only, onte that bias current on the other channel may vary.

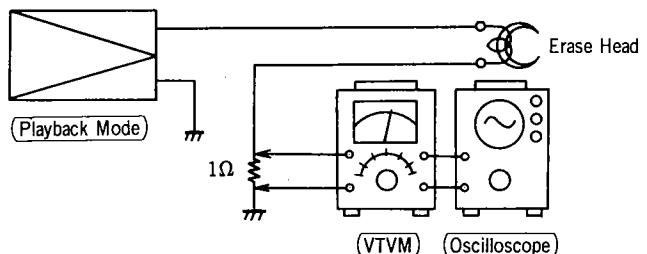
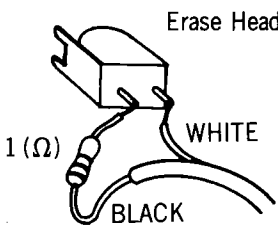
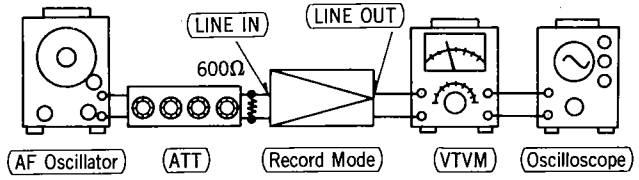
ITEM	MEASUREMENT & ADJUSTMENT	REMARKS
<p>Erase Current</p> <p>Equipment:</p> <ul style="list-style-type: none"> * VTVM * Oscilloscope * Resistor (1Ω) 	<ol style="list-style-type: none"> 1. Connect 1Ω resistor between ground side terminal of erase head ground lead wire removed (See fig. 21). 2. Connect VTVM to both ends of 1Ω resistor.  <p style="text-align: center;">Fig. 20</p> <ol style="list-style-type: none"> 3. Place UNIT into record mode and, measure voltage across the 1Ω resistor. 4. Determine erase current with the following formula. $\text{Erase current (A)} = \frac{\text{Voltage across both ends of } 1 (\Omega)}{1 (\Omega)}$ <div style="border: 1px solid black; padding: 5px; width: fit-content; margin: 10px auto;"> <p style="text-align: center;">Standard Value: 90±20 mA</p> </div>	<p>* Record Mode</p>  <p style="text-align: center;">Fig. 21</p>
<p>Balance (for recording level)</p> <p>Equipment:</p> <ul style="list-style-type: none"> * VTVM * Oscilloscope * AF Oscillator * ATT 	<ol style="list-style-type: none"> 1. Test equipment connection is shown below.  <p style="text-align: center;">Fig. 22</p> <ol style="list-style-type: none"> 2. Place UNIT into record mode, and set the record level control to minimum. 3. Supply 1 kHz signal (-7 dB) from AF oscillator, through ATT, to LINE IN (L-CH). 4. Adjust record level control so that the output level (R-CH) at LINE OUT on VTVM becomes -7 dB. 5. Set the balance volume to (R-CH) maximum. 6. Then measure the output level at LINE OUT (L-CH). 7. Adjust VR1 so that measured value at LINE OUT (R-CH) becomes -7 dB (See adjustment parts location on page 18). 	<p>* Record Mode</p>

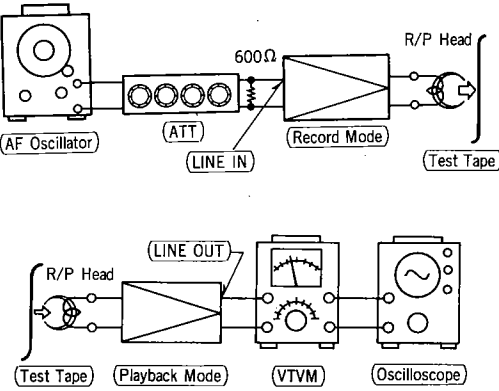
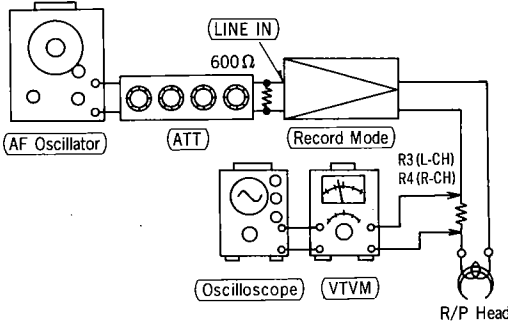
ITEM	MEASUREMENT & ADJUSTMENT	REMARKS
<p>Overall Gain</p> <p>Equipment:</p> <ul style="list-style-type: none"> * AF Oscillator * VTVM * ATT * Oscilloscope * Test Tape (Reference Blank Tape) <p>C-RA for Normal C-RF for CrO₂</p>	<p>1. Test equipment connection is shown in fig. 23.</p>  <p style="text-align: center;">Fig. 23</p> <ol style="list-style-type: none"> 2. Place UNIT into record mode, and equalizer selector to 120μS, bias selector to LOW (for normal tape). 3. Supply 1 kHz signal (-24 dB) from AF oscillator, through ATT, to LINE IN. 4. Adjust ATT until monitor level at LINE OUT becomes 0.42 V (-7 dB). 5. Using test tape (C-RA), make recording. 6. Playback recorded tape, and make sure the value at LINE OUT on VTVM becomes 0.42 V. 7. If measured value is not 0.42 V, adjust VR15 (L-CH), VR16 (R-CH) (See fig. 36 on page 18). 8. Repeat from step (2). 9. For CrO₂ tape, equalizer selector to 70μS and bias selector to HIGH, change test tape to (C-RF), and take the same steps for normal but to adjust, use VR17 (L-CH) and VR18 (R-CH). <p>How To Check Recording Current</p>  <p style="text-align: center;">Fig. 24</p>	<ul style="list-style-type: none"> * Record/Playback Mode * LINE IN Level Control ...MAX. * Standard Input Level: <ul style="list-style-type: none"> MIC -72\pm3 dB LINE IN -24\pm3 dB

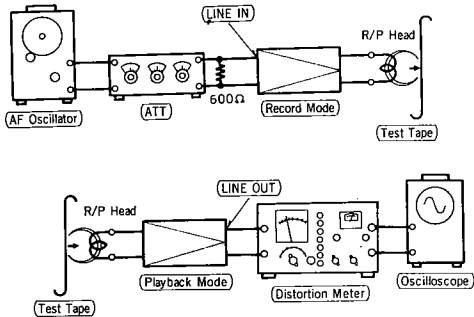
ITEM	MEASUREMENT & ADJUSTMENT	REMARKS
	<ol style="list-style-type: none"> 1. Test equipment connection is shown in fig. 24. 2. Stop bias oscillation by unsoldering a wire (C) shown in adjustment parts location on page 18. 3. Supply 1 kHz signal (-24 dB) again and adjust ATT until monitor level at LINE OUT becomes 0.42 V. 4. Measure voltage and then calculate recording current by formula given below. $\text{Recording current} = \frac{\text{Value read on VTVM (V)}}{10 (\Omega)}$ <div style="border: 1px solid black; padding: 5px; width: fit-content; margin: 10px auto;">Standard Value: 40μA</div> 5. At this time, set the equalizer selector to 70μS and bias selector to HIGH (for CrO₂ tape) and confirm variation of recording current. <div style="border: 1px solid black; padding: 5px; width: fit-content; margin: 10px auto;">Standard Value: 56μA \pm 1 dB</div> 	<p>R3, R4 are shown in AMP circuit board on page 21.</p>
<p>Level Meter Equipment: * VTVM * Oscilloscope * AF Oscillator * ATT</p>	<ol style="list-style-type: none"> 1. Test equipment connection is shown in fig. 22. 2. Supply 1 kHz signal (-24 dB) from AF oscillator, through ATT, to LINE IN jack. 3. Adjust Line input level control so that monitor level at LINE OUT becomes 0.42 V. 4. Adjust VR21 (L-CH), VR22 (R-CH) so that VU meter indicates 0 VU (See adjustment parts location on page 18). 	<p>* Record Mode</p>
<p>Overall Distortion Equipment: * Distortion Meter * AF Oscillator * ATT * Oscilloscope * Test Tape (Reference Blank Tape)...C-RA</p>	<ol style="list-style-type: none"> 1. Test equipment connection is shown in fig. 25. 2. Supply 1 kHz signal to LINE IN and adjust ATT so that output level at LINE OUT indicates 0.42 V (-7 dB). 3. Make recording. 4. Play back, and measure distortion factor of output signal. 5. When the distortion factor does not satisfy the standard, check the bias current. When the bias current is lower than standard, distortion will increase. <p>Care should be exercised in the adjustment because the bias current also has an influence on the overall frequency response. Refer to "The Overall Frequency Response" and "The Bias Current Adjustment".</p> <div style="text-align: center;">  </div> <div style="text-align: center; margin-top: 10px;"> Fig. 25 </div> <div style="border: 1px solid black; padding: 10px; width: fit-content; margin: 10px auto;"> <p>Standard Value: less than 2.3%Normal less than 3.2%CrO₂</p> </div>	<p>* LINE IN Level Control ...MAX.</p>

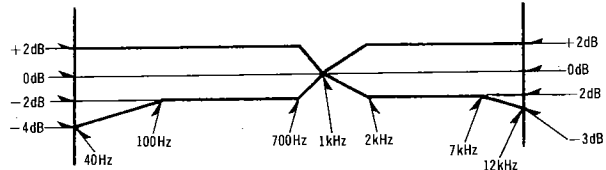
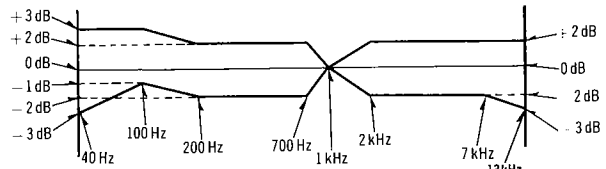
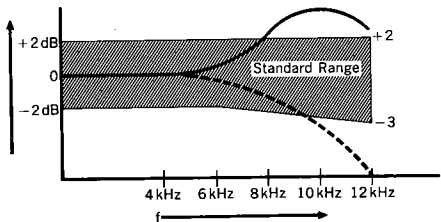
ITEM	MEASUREMENT & ADJUSTMENT	REMARKS
<p>Overall Frequency Response</p> <p>Equipment:</p> <ul style="list-style-type: none"> * VTVM * AF Oscillator * ATT * Test Tape (Reference Blank Tape) ...C-RA for Normal ...C-RF for CrO₂ 	<p>Note:</p> <p>Before measuring and adjusting, make sure of the playback frequency response (For the method of measurement, please refer to the playback frequency response).</p> <ol style="list-style-type: none"> 1. Test equipment connection is shown in fig. 23. 2. Load reference blank test tape and place UNIT into record mode. 3. Supply 1 kHz signal from AF oscillator through ATT to LINE IN. 4. Adjust ATT so that input level is -20 dB below standard recording level (standard recording level=0 VU). 5. At this time, LINE OUT level indicates 0.042 V. 6. Record each frequency 40 Hz, 100 Hz, 700 Hz, 1 kHz, 2 kHz, 7 kHz, 10 kHz and 12 kHz (13 kHz for CrO₂) at the same level. 7. Play back and express in dB the difference between playback output level of each frequency based on playback output level of 1 kHz. 8. Make sure that the measured value is within the range specified in the overall frequency response chart. <p>Overall Frequency Response Chart (Normal)</p>  <p style="text-align: center;">Fig. 26</p> <ol style="list-style-type: none"> 9. Set the equalizer selector to 70μS and bias selector to HIGH (for CrO₂ tape). 10. Measure as same as manner above. 11. Make sure that the measured value is within the range specified in the overall frequency response chart for CrO₂ tape below. <p>Overall Frequency Response Chart (CrO₂)</p>  <p style="text-align: center;">Fig. 27</p> <p>Adjustment 1-Using bias current</p>  <p style="text-align: center;">Fig. 28</p>	<ul style="list-style-type: none"> * Record/Playback Mode * Record Level Control ...MAX.

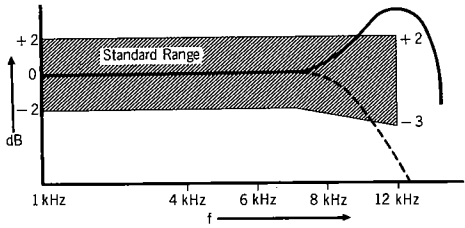
ITEM	MEASUREMENT & ADJUSTMENT	REMARKS
<p>Overall Frequency Response (As a Standard for Adjustment)</p>	<ol style="list-style-type: none"> When the frequency response between the middle-and high-frequency range becomes higher than the standard value, as shown by the solid line in figure 28 increase the bias current by turning VR301 (L-CH), VR302 (R-CH) for normal and VR303 (L & R CH) for CrO₂ tape. When it becomes lower, as shown by dotted line, reduce the bias current by turning in the direction opposite to arrow indication. <p>Note:</p> <ol style="list-style-type: none"> For adjustment when the bias current is lower than the standard value 0.17 mA, use the procedure indicated in adjustment 2, because reducing the bias current beyond this point may worsen the distortion factor. For the method of bias current measurement, refer to "Bias Current Adjustment" on page 10. <p>Adjustment 2—Using the peaking coil for recording equalization</p>  <p style="text-align: center;">Fig. 29</p> <ol style="list-style-type: none"> When the frequency response is flat in the middle-frequency range and makes a sharp rise or drop in the high-frequency range, as shown in figure 29, adjust by turning the peaking Coil L3 (L-CH), L4 (R-CH) for normal tape recording equalization and L5 (L-CH) L6 (R-CH) for CrO₂ tape recording equalization. 	
<p>Overall S/N Ratio Equipment : * VTVM * AF Oscillator * ATT * Oscilloscope * Test Tape (Reference Blank Tape)...C-RA</p>	<ol style="list-style-type: none"> Test equipment connection is shown in fig. 23. Supply 1 kHz signal to LINE IN and adjust ATT so that output level at LINE OUT indicates 0.42 V (-7 dB). Make recording. Make another recording without supplying signal (disconnect input plug to LINE IN). Rewind to recorded part and playback. Measure output signal level and no signal level (noise), and determine the ratio in decibels (dB). The value is different between "playback S/N and overall S/N", but for decibel calculation refer to "Playback S/N measurement" on page 9. <div style="border: 1px solid black; padding: 5px; text-align: center; margin: 10px auto; width: fit-content;"> <p>Standard Value: Greater than 43 dB (without NAB filter)</p> </div>	<ul style="list-style-type: none"> * Record/Playback Mode * LINE IN Level Control ...MAX * Erase the tape with a bulk tape eraser.
<p>Dolby NR Circuit Equipment : * VTVM * AF Oscillator * ATT * Oscilloscope</p>	<ol style="list-style-type: none"> Place UNIT into record mode, set the Dolby NR switch to OUT position and supply to LINE IN to obtain -34.5 dB at TP3 (L-CH), TP4 (R-CH) (frequency 5 kHz). Confirm that the value at IN position is 8 dB greater than the value at OUT position of Dolby NR switch. When it is not in condition above, adjust as follows. Set VR11 (L-CH), VR12 (R-CH) to maximum. Set the Dolby NR switch to IN position. At this time adjust VR13 (L-CH), VR14 (R-CH) so that the reading of VTVM become 10 dB greater than the value in step (1) above. Adjusting VR11 (L-CH), VR12 (R-CH), make the reading of VTVM become 2 dB smaller than the value obtained through the adjustment in step (6) above. 	<ul style="list-style-type: none"> * Record Mode * LINE IN Level Control ...MAX * Stop the bias oscillation by unsoldering a wire (C) shown in adjustment parts location on page 18.

V. HOW TO INSTALL PLUNGERS AND SWITCHES

1. Playback plunger (See fig. 30)

Move the solenoid in direction **(B)** with the plunger completely drawn in direction **(A)**.

Secure the solenoid by using the screws **(E)**, at the position where the parts **(C)** and **(D)** of the head base plate each contact the shaft.

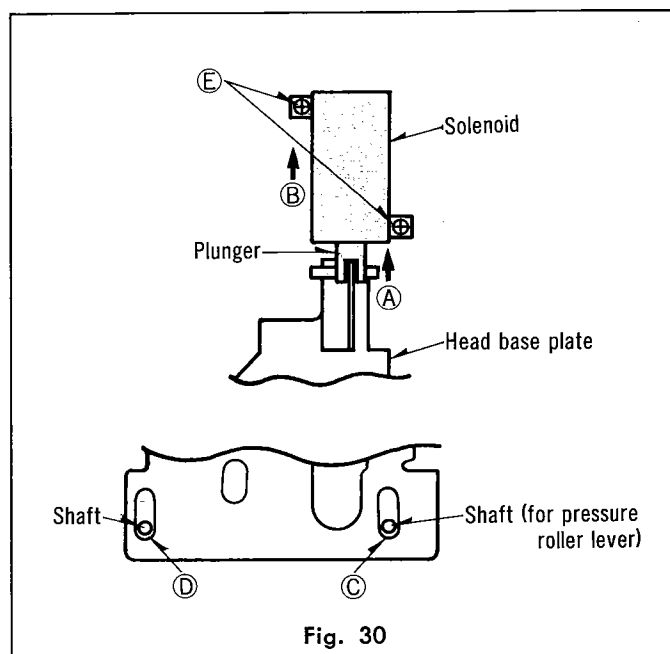

2. Record plunger (See fig. 31)

Move the solenoid in direction **(B)** with the plunger completely drawn in direction **(A)**.

After pushing the switch rod of the slide switch completely in direction **(C)**, secure the solenoid by using the screw **(D)**.

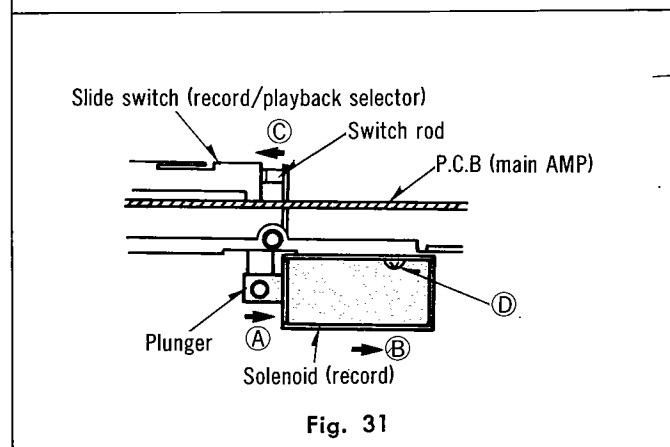

3. Fast forward/rewind plunger (See fig. 32)

Move the solenoid in direction **(B)** with the plunger completely drawn in direction **(A)**.

Then secure the solenoid by using the screw **(D)** after adjusting the clearance **(C)** between the eject lever and the eject arm pin to a range of between 0 to 0.5 mm.

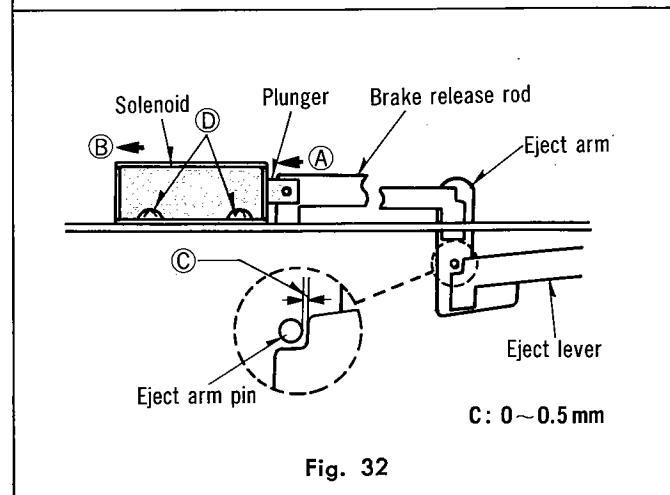

4. Auto-stop plunger (See fig. 33)

Move the solenoid in direction (B) with the plunger completely drawn in direction (A).

The solenoid can be secured with the screw immediately as the lock lever is completely drawn in direction (C).

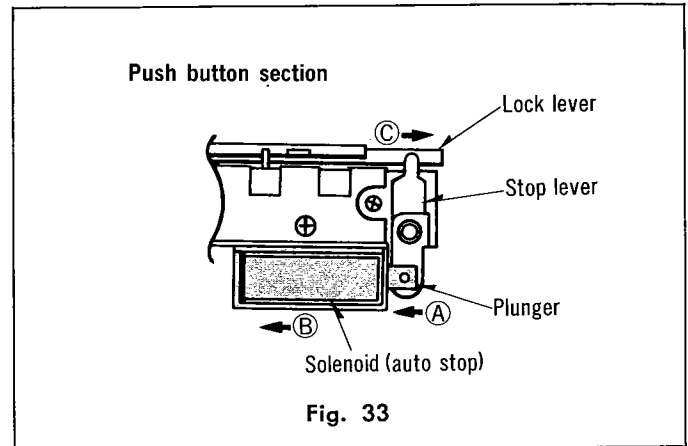

5. Reed switch (See fig. 34)

The reed switch detects the auto-stop, and is operated by magnetism released from the magnet in the connection pulley.

The reed switch should be secured by screw (B) when gap (A) between the magnet and the reed switch has a width of 0.5 ± 0.2 mm.

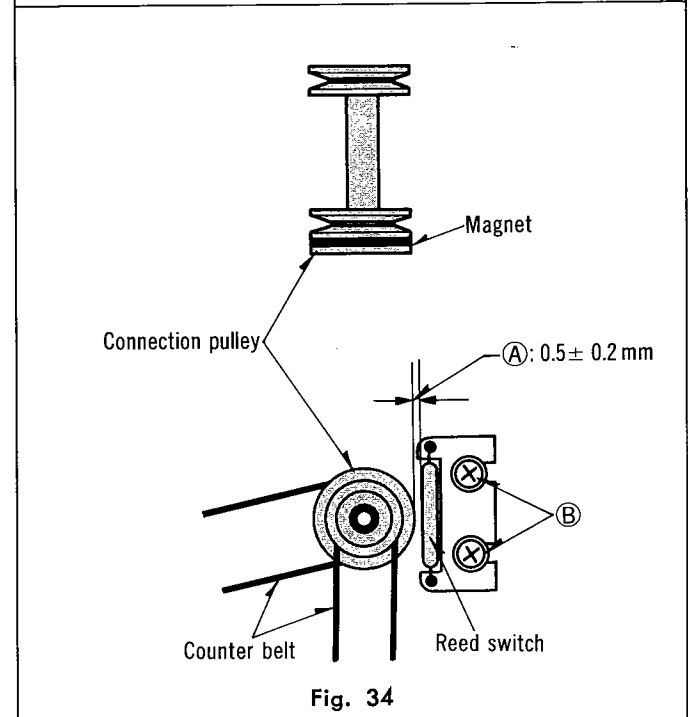

6. Micro switch (See fig. 35)

The micro switch can be adjusted by inserting a tape cassette with a projection on the cassette.

1. Erase safety switch

The micro switch should be secured by screw (B) when gap (A) has a width of between 0.5 and 1 mm.

At this time, confirm that the switch is completely on.

2. Power supply switch

After moving the micro switch in direction (C), the micro switch can be secured by the screw (D) immediately after it is turned on by the cassette pressure lever.

Confirm whether the micro switch is turned off or not when the tape cassette is removed.

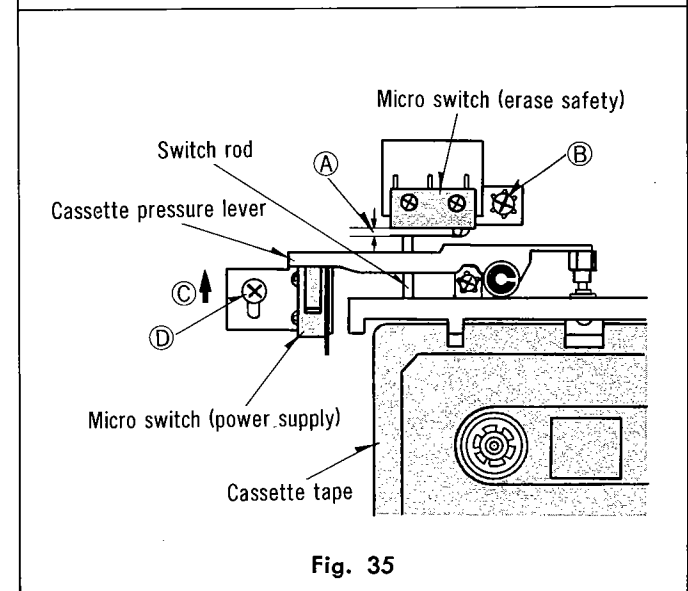

ADJUSTMENT PARTS LOCATION

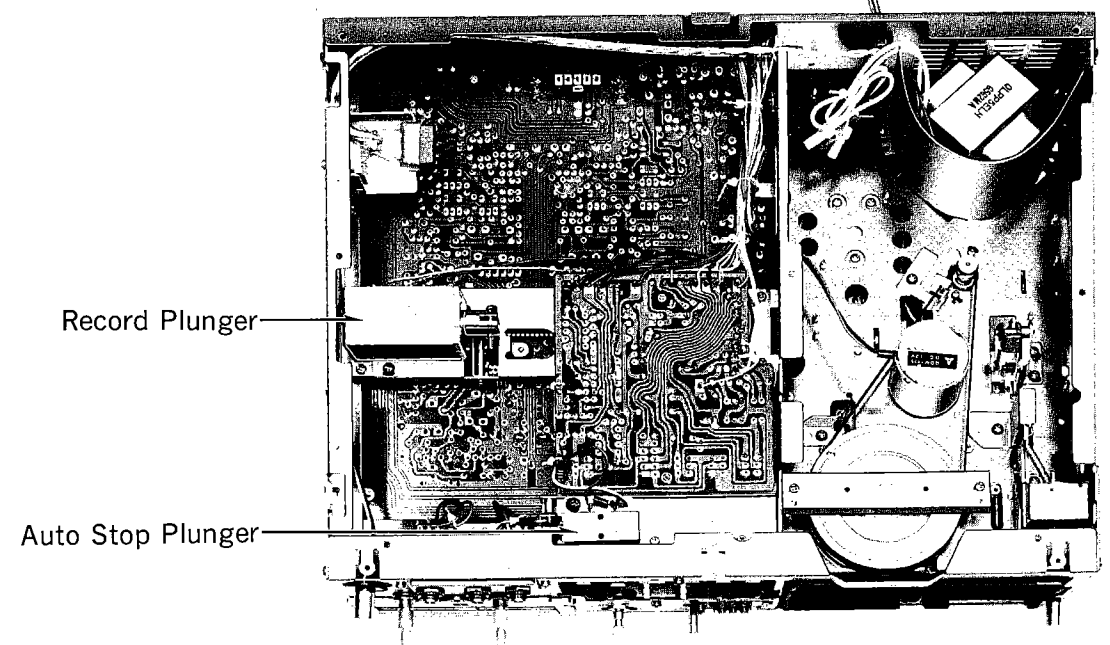
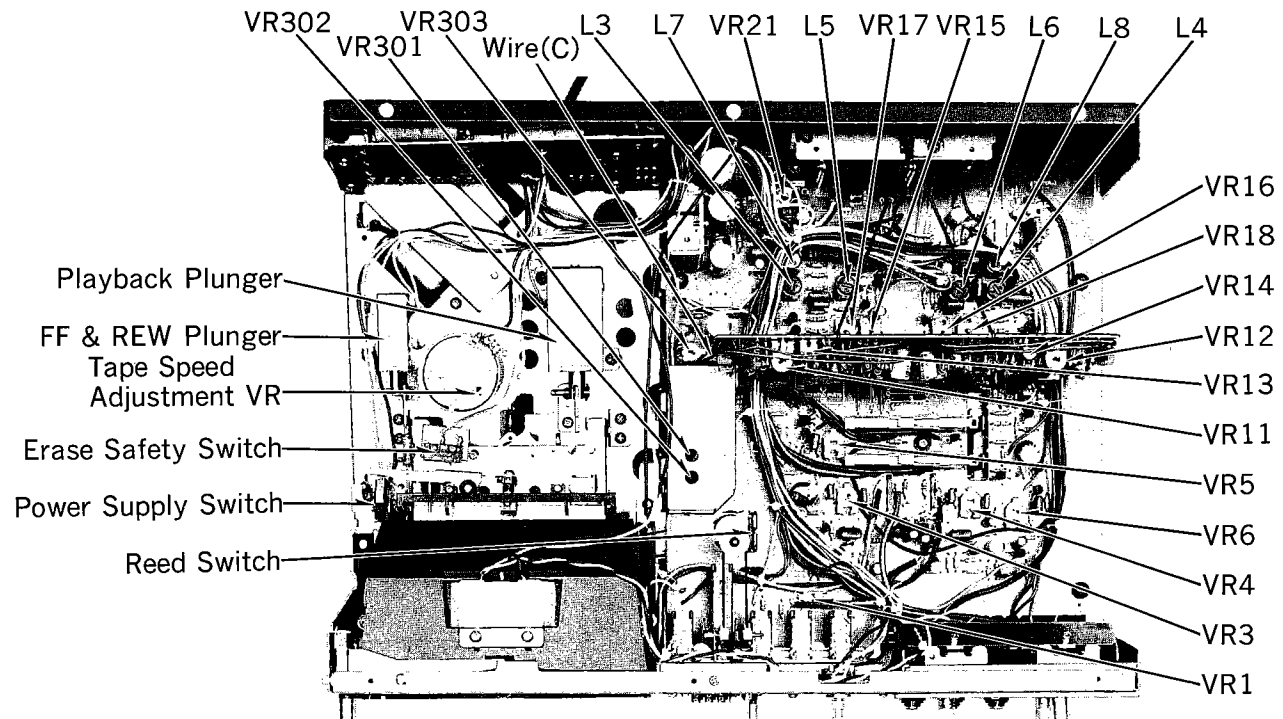
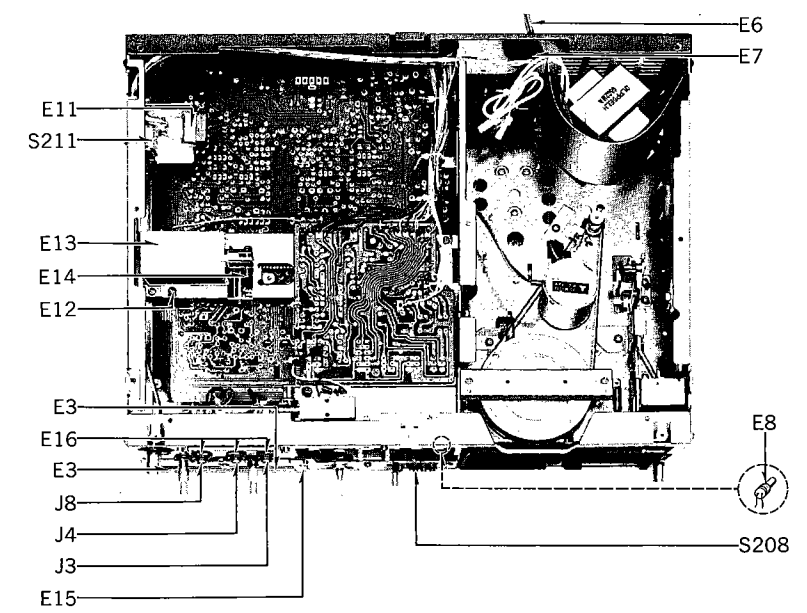
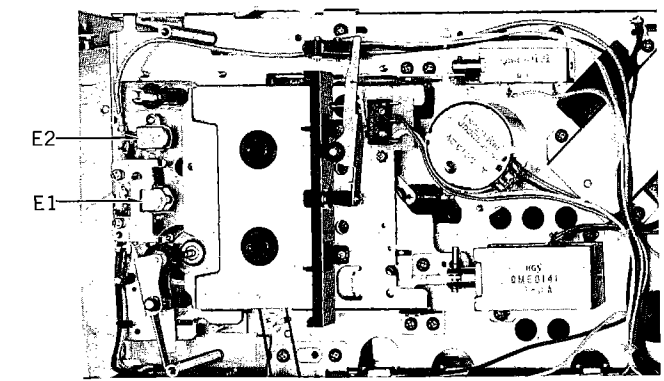
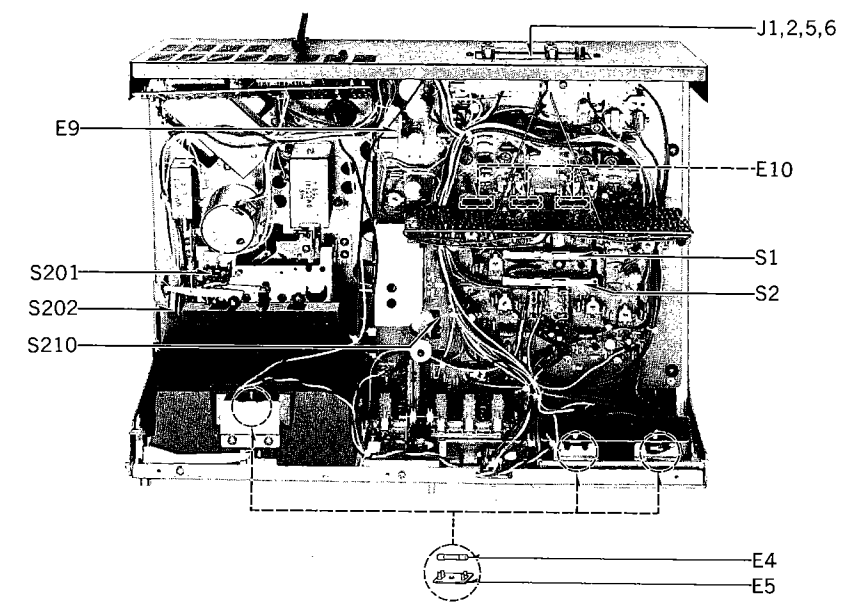
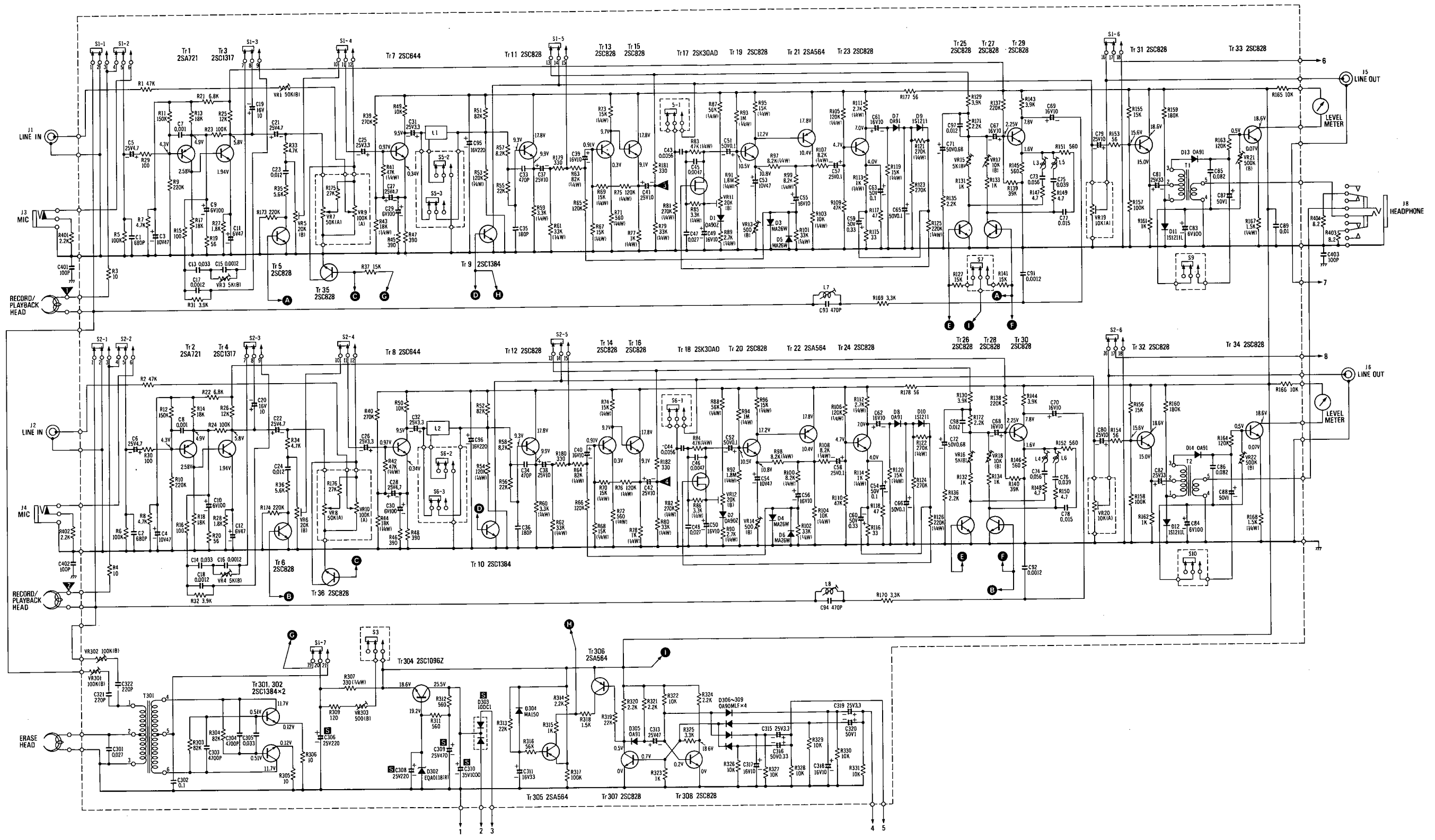

Fig. 36

ELECTRICAL PARTS LOCATION



SCHEMATIC DIAGRAM MODEL RS-671US



TERMINATIONS (BOTTOM VIEW)

Tr1~16, 19~36
201, 202, 204~207
209, 210
301, 302, 305, 306

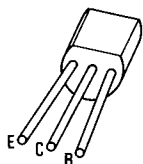

Tr17, 18

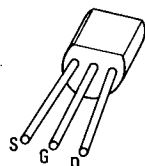

Tr 203, 208, 304

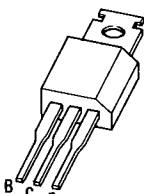

T1,2

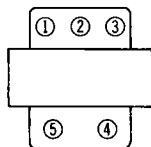

T301

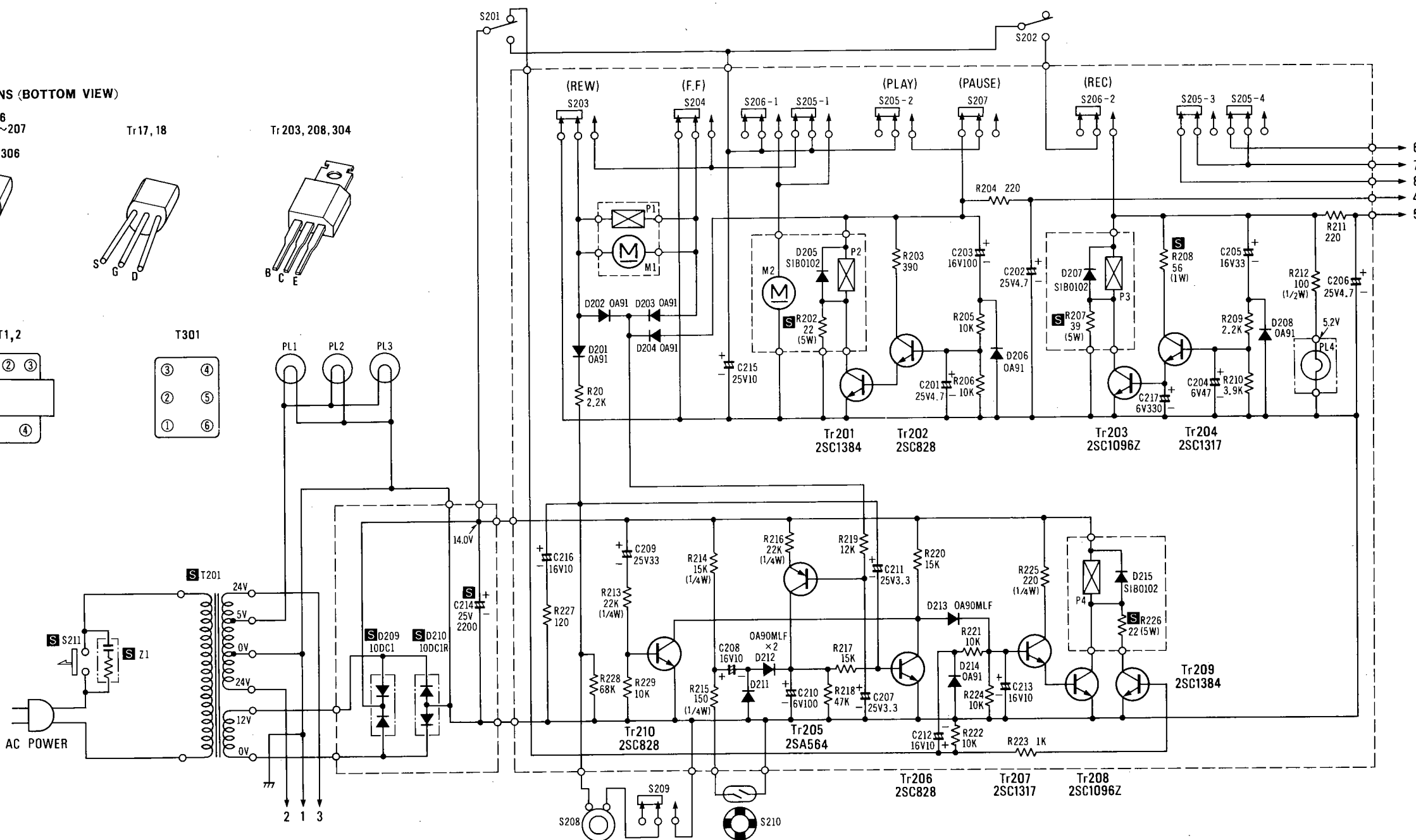
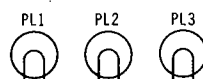
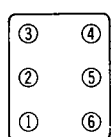

NOTE:

1. S1-1~S1-7, 2S-1~S2-7 ... Record/playback select switch (shown in playback position).
2. S3 Bias selector switch (shown in LOW position).
3. S5-1~S5-3, S6-1~S6-3 ... Dolby noise-reduction switch (shown in OUT position).
4. S7 Equalization selector switch (shown in 120µS position).
5. S8, S9 Peak-signal check switch (shown in OUT position).
6. S201..... Power supply switch.
7. S202..... Erase safety switch.
8. S203..... Rewind button switch.
9. S204..... Fast forward button switch.
10. S205-1~S205-4 Playback button switch.
11. S206-1, S206-2 Record button switch.
12. S207..... Pause button switch.
13. S208..... Memory counter switch.
14. S209..... Memory-rewind switch.
15. S210..... Reed switch (tape end detector).

16. S211..... Power ON/OFF switch.
17. VR1 LINE IN input level balance adjustment VR.
18. VR3, 4 Playback equalizer adjustment VR.
19. VR5, 6 Playback level adjustment VR.
20. VR7, 8 Microphone level control.
21. VR9, 10 LIN IN input level control.
22. VR11~14 Dolby NR adjustment VR.
23. VR15, 16 Standard recording current adjustment VR (for normal tape).
24. VR17, 18 Standard recording current adjustment VR (for CrO₂ tape).
25. VR19, 20 Output level control.
26. VR21, 22 Level meter adjustment VR.
27. VR301, 302 Bias current adjustment VR.
28. VR303 Bias current adjustment VR (for CrO₂ tape).
29. L3, 4 Record equalizer adjustment coil (for normal tape).

30. L5, 6 Record equalizer adjustment coil (for CrO₂ tape).
31. L7, 8 Bias trap adjustment coil.
32. P1 FF & REW plunger.
33. P2 Playback plunger.
34. P3 Record plunger.
35. P4 Auto stop plunger.
36. Resistor values are in ohme (Ω), 1/8 watt unless specified otherwise. K=1,000Ω.
37. Capacitor values are in microfarads (µF) unless specified otherwise. P=Pico-farads.
38. The mark (▼) shows test point. e.g. ▼=test point 1.
39. All measurements are under no signal conditions with volume at minimum position. Use VTVM for voltage measurements.
40. ■ indicates that only parts specified by the manufacturer be used for replacement in critical circuits.

CIRCUIT BOARD

MAIN CIRCUIT BOARD

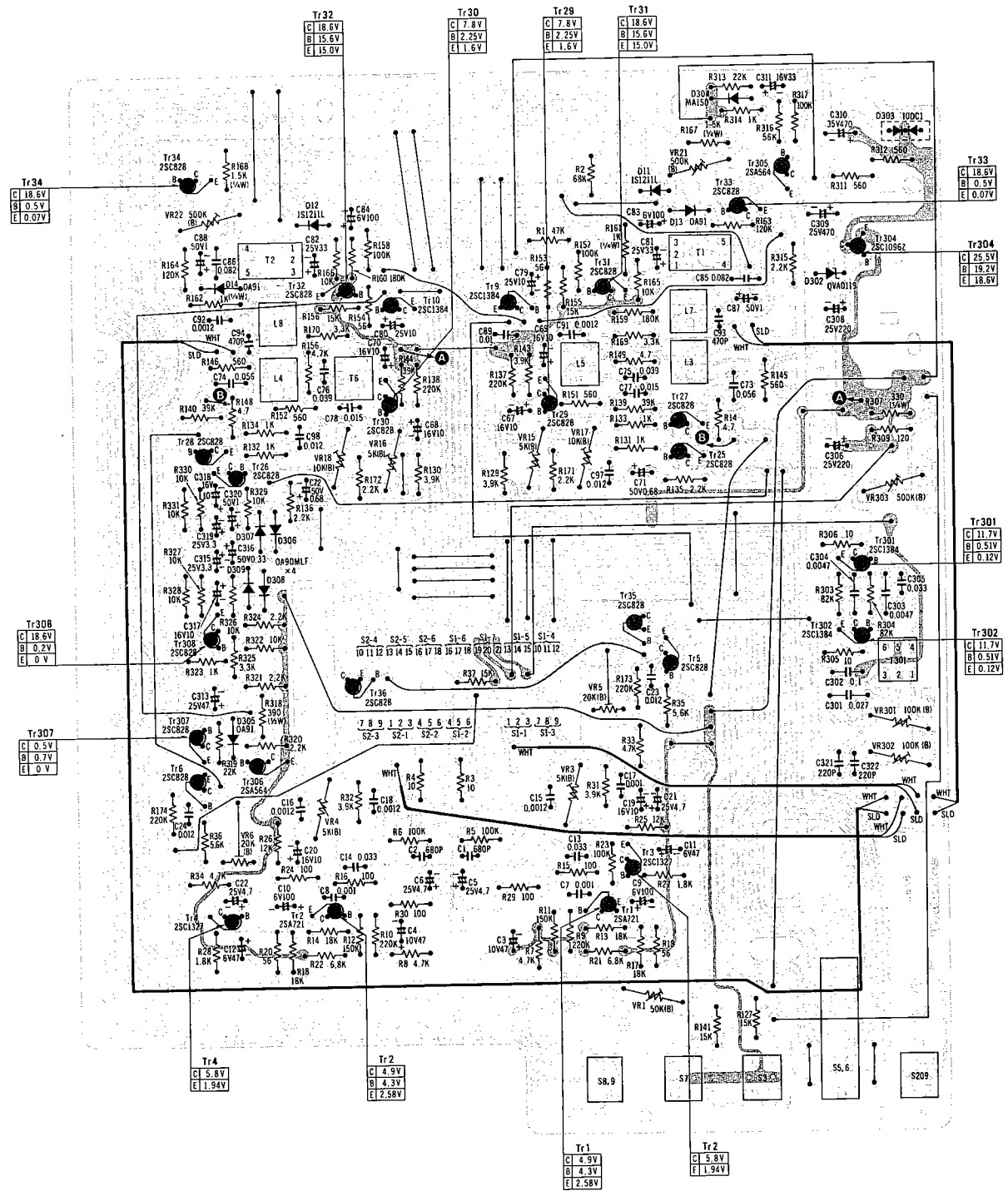

DOLBY CIRCUIT BOARD

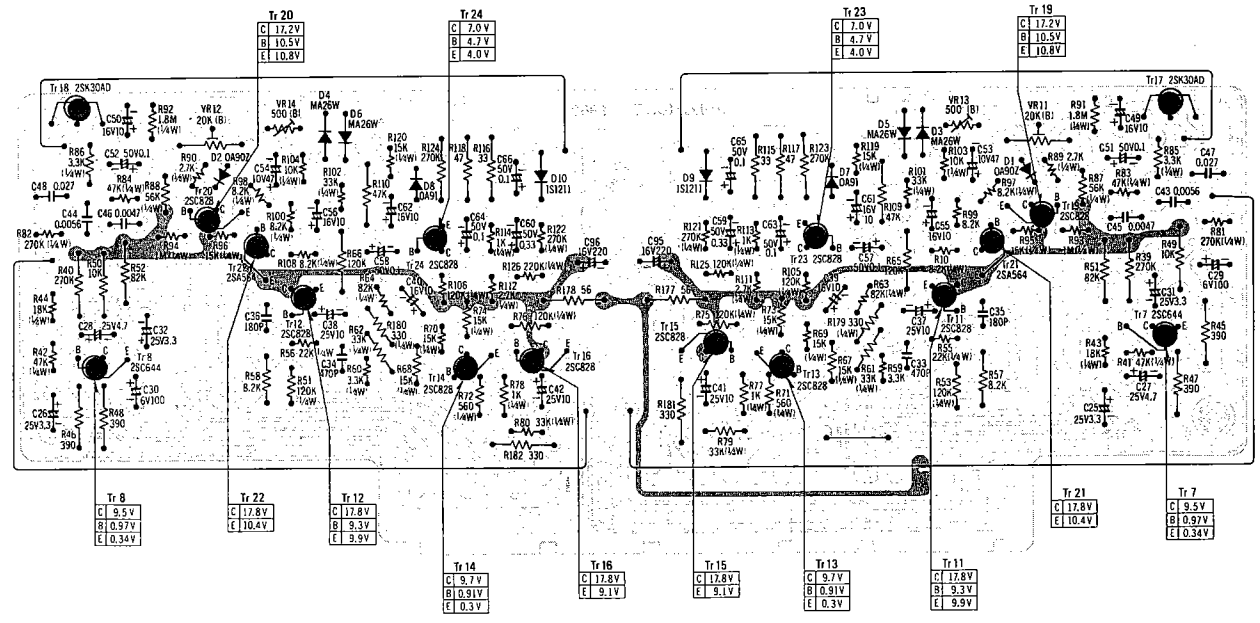

CONTROL CIRCUIT BOARD

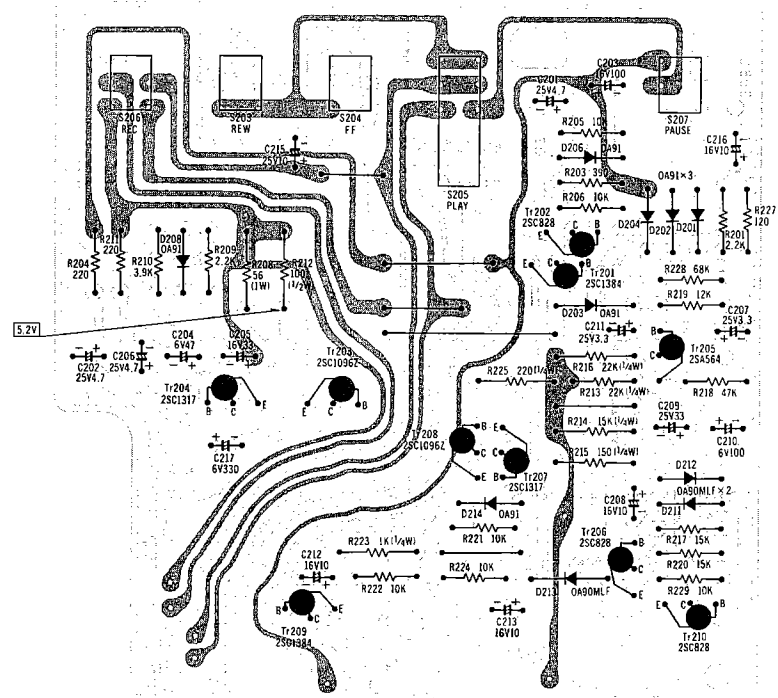

RESISTOR CIRCUIT BOARD

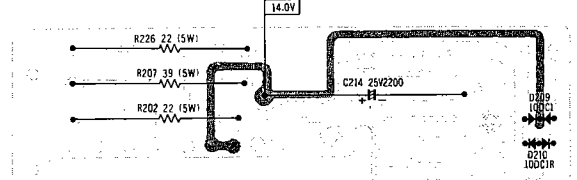

VOLUME CIRCUIT BOARD

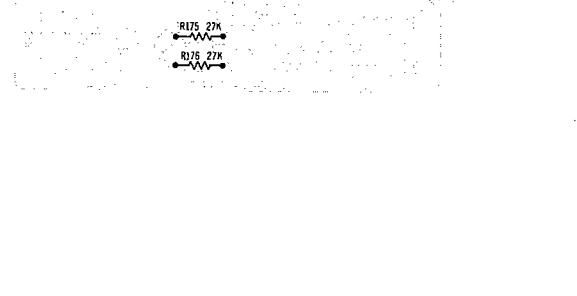

NOTE:
The circuit shown in red on the conductor is B circuit.
Values indicated in are DC voltages between the chassis and electrical parts.

WIRING CONNECTION DIAGRAM MODEL RS-671US

NOTE:

- BLKBlack
- BLUBlue
- BRNBrown
- GRYGray
- GRNGreen
- L. BLU...Light Blue
- NILNo Color Mark
- ORGOrange
- PNKPink
- REDRed
- SLDShield Wire
- VLTViolet
- WHT ...White
- YELYellow

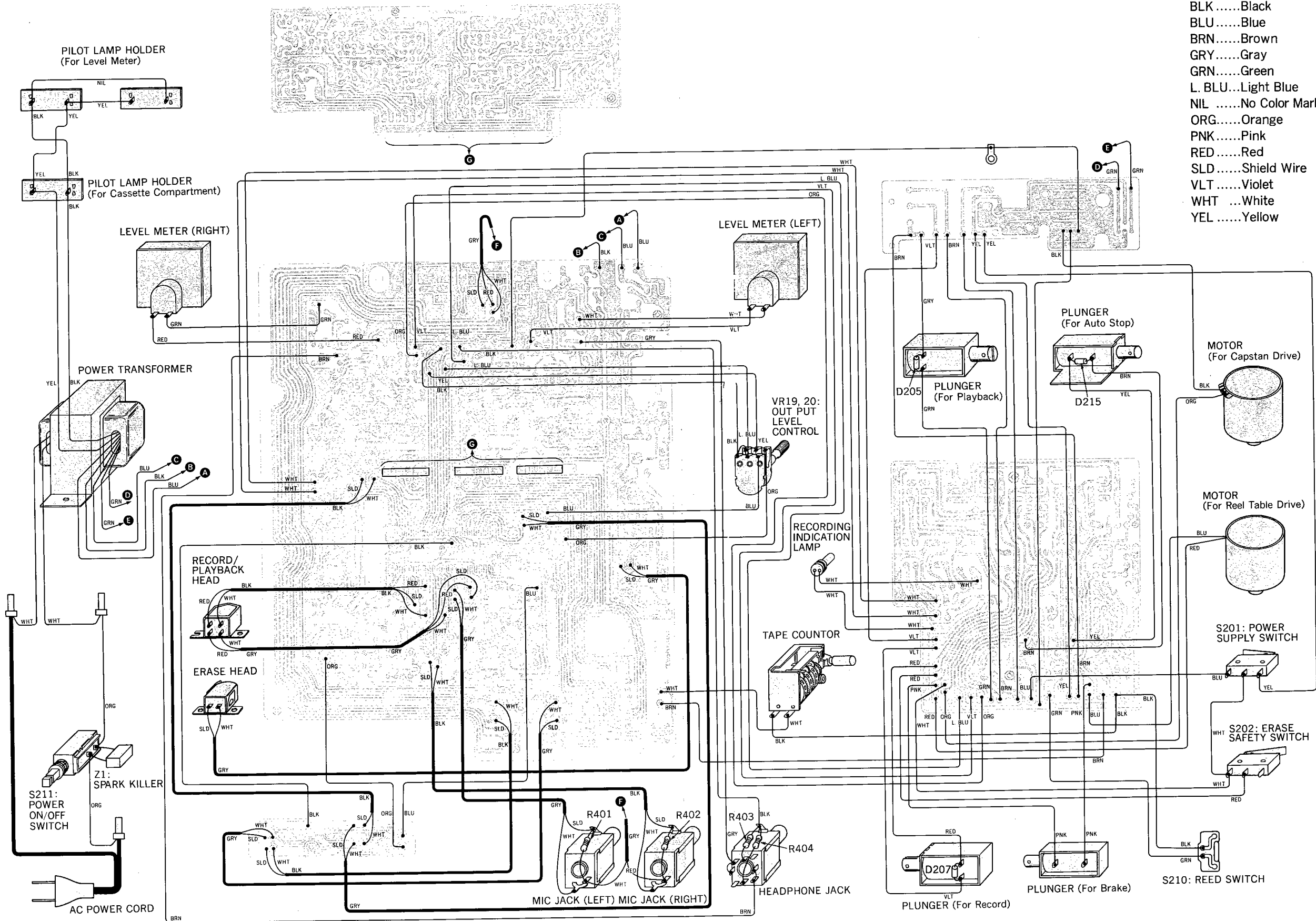

EXPLODED VIEWS

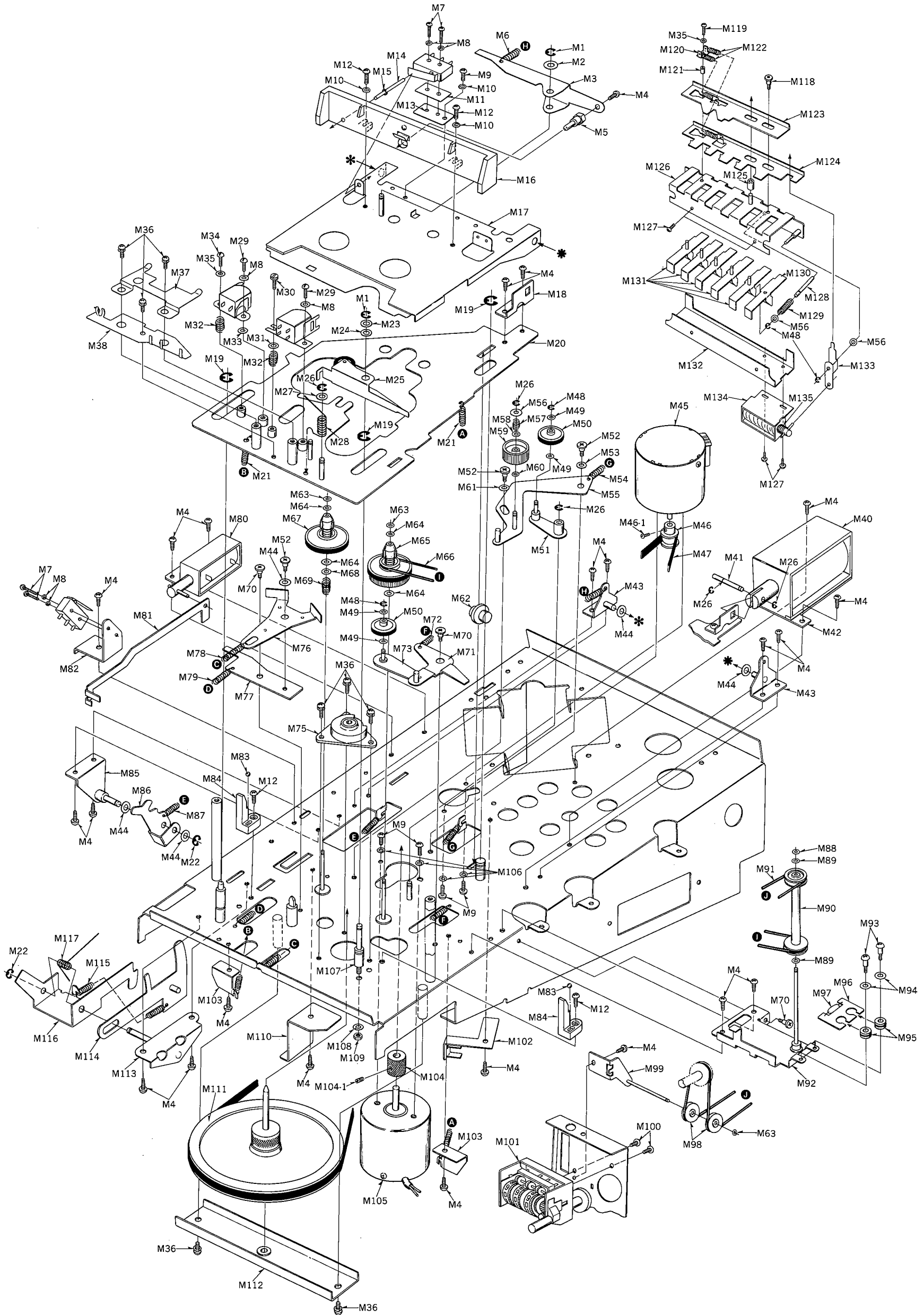

CABINET PARTS

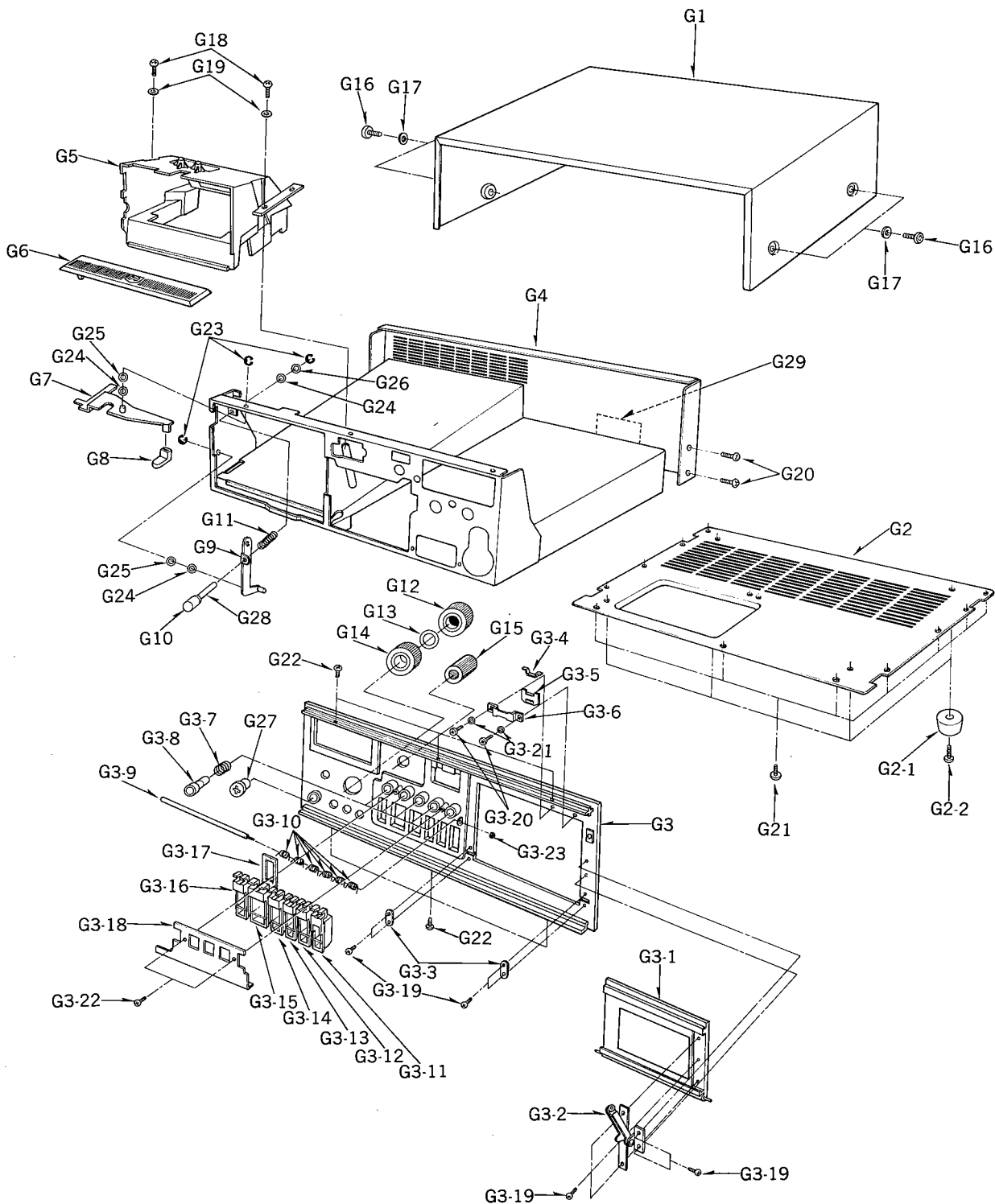

COMPONENT PACKING

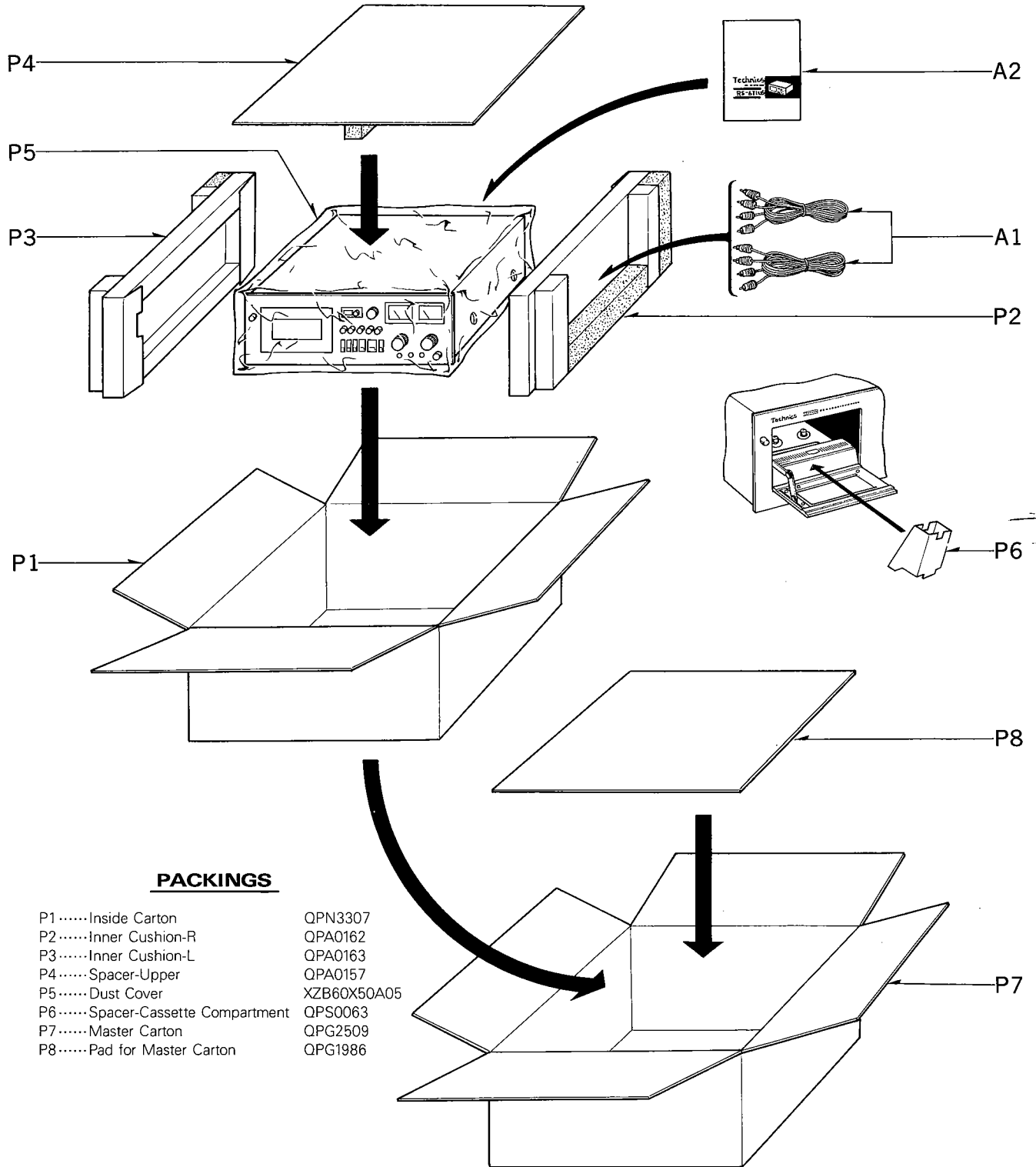

PACKINGS

- | | |
|------------------------------------|-------------|
| P1.....Inside Carton | QPN3307 |
| P2.....Inner Cushion-R | QPA0162 |
| P3.....Inner Cushion-L | QPA0163 |
| P4.....Spacer-Upper | QPA0157 |
| P5.....Dust Cover | XZB60X50A05 |
| P6.....Spacer-Cassette Compartment | QPS0063 |
| P7.....Master Carton | QPG2509 |
| P8.....Pad for Master Carton | QPG1986 |

REPLACEMENT PARTS LIST

MODEL RS-671US (Panasonic)

ATTENTION:

1. Be sure to make your orders of replacement parts according to this list.
2. **SAFETY** indicates that only parts specified by the manufacturer be used for replacement in critical circuits.

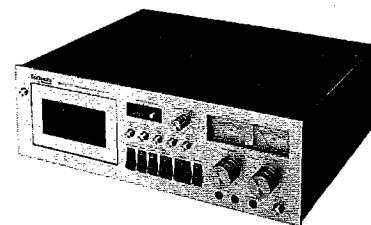

RS-671US

Ref. No.	Description	Part No.	Per Set (Pcs.)		Note
<u>MECHANICAL PARTS</u>					
M1	Stop Ring 3φ	XUC3FT	2		COMMON
M2	Fiber Washer	QBK7005	1		RS-676US
M3	Cassette Pressure Lever	QML2695A	1		"
M4	Tapping Screw ⊕3×8	XTN3+8BFX	23		COMMON
M5	Cassette Pressure Piece	QKJ0108	1		
M6	Cassette Pressure Lever Spring	QBT1431M	1		RS-676US
M7	Screw ⊕2×10	XSN2+10FX	4		COMMON
M8	Spring Washer 2φ	XWA2B	6		" "
M9	Screw ⊕2.6×6	XSN26+6FX	5		"
M10	Lock Washer 2.6φ	XWC26B	3		"
M11	Shield Plate	QBK1217	1		RS-676US
M12	Screw ⊕2.6×6	XSN26+6FX	4		COMMON
M13	Switch Holding Plate	QMF1682	1		RS-676US
M14	Switch Rod	QMR1388	1		"
M15	Stop Ring 1.5φ	XUC15FT	1		COMMON
M16	Cassette Retainer	QXZ0042	1		
M17	Cassette Base Plate Assembly	QXK1478A	1		RS-676US
M18	Head Base Plate Transfer Angle	QMA2661	1		
M19	Stop Ring 5φ	XUC5FT	3		COMMON
M20	Head Base Plate Assembly	QXK1692	1		
M21	Head Base Plate Return Spring	QBT1750M	2		RS-676US
M23	Washer	QBJ3215	1		"
M24	"	QBJ3214	1		"
M25	Pressure Roller Lever Assembly	QXL0970A	1		"
M26	Stop Ring 2.5φ	XUC25FT	5		COMMON
M27	Fiber Washer	QBK7121	1		RS-676US

Ref. No.	Description	Part No.	Per Set (Pcs.)	Note
M28	Pressure Roller Lever Spring	QBN1473	1	
M29	Screw $\ominus 2 \times 4$	XSN2-4FX	2	COMMON
M30	Head Adjustment Screw	QH1211	1	RQ-454S
M31	Spacer	QMC0014	1	RS-676US
M32	Head Spring	QBC1235	2	"
M33	Fiber Washer	QBK7122	1	"
M34	Screw $\ominus 2 \times 6$	XSN2-6FX	1	COMMON
M35	Flat Washer	XWE2	1	"
M36	Screw $\oplus 3 \times 6$	XYN3+C6FXS	8	"
M37	Cassette Holder	QMF1697A	1	RS-676US
M38	Wire Clamper	QMF1792	1	
M40	Plunger (Playback)	QME0141A	1	RS-676US
M41	Plunger Shaft	QMN1817	1	"
M42	Plunger Holding Plate	QMF1684	1	"
M43	Cassette Base Plate Holding Angle	QXA0292A	2	"
M44	Fiber Washer	QBK7007	5	"
M45	Motor (for Reel Table Drive)	MHI5R2CQP	1	
M46	Motor Pulley Assembly	QXP0492	1	
M46-1	Screw $\oplus 2.6 \times 4$	XSN26+4FX	1	COMMON
M47	Capstan Belt	QDB0202A	1	RS-676US
M48	Stop Ring 2ϕ	XUC2FT	2	COMMON
M49	Washer	QBJ3291	4	RS-676US
M50	Fast Forward Idler	QXI0033	2	"
M51	Idler Lever	QXL0810A	1	"
M52	Screw	QH1177S	3	"
M53	Washer	QBJ3216	1	"
M54	Fast Forward Lever Spring	QBT1771M	1	"
M55	Fast Forward Lever Assembly	QXL0809	1	"
M56	Fiber Washer	QBK7124	2	"
M57	Fast Forward Friction Spring	QBC1239	1	"
M58	Washer	QBJ3290	1	"
M59	Fast Forward Lever Idler	QDP1587	1	"
M60	Felt Washer	QBF1194	1	"
M61	Washer	QBH0091	1	"
M62	Roller	QDP1586	1	"

RS-671US

Ref. No.	Description	Part No.	Per Set (Pcs.)	Note
M63	Nylon Snap Washer	QWQ1124	3	RS-676US
M64	Mylar Washer	QBJ3224	4	"
M65	Takeup Reel Table Assembly	QXD0047A	1	"
M66	Counter Belt-A	QDB0215	1	
M67	Supply Reel Table Assembly	QXD0032	1	RS-676US
M68	Washer	QBW2013	1	RS-263AUS
M69	Back Tension Spring	QBC1272	1	
M70	Step Screw	QHQ1168	3	RS-676US
M71	Takeup Idler Lever Assembly	QXL0803	1	"
M72	Takeup Idler Lever Spring	QBT1409M	1	"
M73	Takeup Idler Arm Assembly	QXL0811	1	"
M75	Capstan Shaft Retainer Assembly	QXM0139	1	"
M76	Brake	QML2679A	1	
M77	Brake Lever	QML2913	1	
M78	Brake Spring	QBT1561	1	RS-676US
M79	Brake Lever Spring	QBT1757M	1	"
M80	Plunger (Fast Forward & Rewind)	QME0131	1	RS-276US
M81	Brake Release Rod	QMR1483	1	
M82	Switch Angle	QMA2379A	1	RS-676US
M83	Steel Ball	QDK1006	2	RS-451S
M84	Spacer	QMZ1168	2	
M85	Click Lever Angle Assembly	QXA0291	1	RS-671US
M86	Click Lever	QML2685	1	"
M87	Click Lever Spring	QBT1758M	1	"
M88	Nylon Snap Washer	QBW2007	1	RO-454S
M89	Washer	QBW2015	1	"
M90	Connection Pulley	QXP0514	1	
M91	Counter Belt-B	QDB0221	1	
M92	Connection Pulley Angle-A Assembly	QXA0458	1	
M93	Step Screw	QMS1833	2	RS-676US
M94	Flat Washer	XWG3	2	COMMON
M95	Rubber Cushion	QBG1431	2	RS-676US
M96	Reed Switch Holding P.C.B.	QJI0661	1	
M97	Reed Switch	Refer to S210	(1)	
M98	Connection Pulley	QBJ2088	2	RS-676US

Ref. No.	Description	Part No.	Per Set (Pcs.)	Note
M99	Connection Pulley Angle-B Assembly	QXA0457	1	
M100	Screw $\oplus 3 \times 6$	XSS3+6FX	2	COMMON
M101	Tape Counter	QDC0066	1	RS-676US
M102	Belt Prevention Angle	QMA2540	1	
M103	Spring Hanger	QMA2315A	2	RS-676US
M104	Motor Pulley Assembly	QXP0505	1	
M104-1	Pulley Set Screw	XXA26D4P	1	RS-676US
M105	Motor (for Capstan Drive)	QDM1335	1	"
M106	Spring Washer	XWA26B	4	COMMON
M107	Pressure Roller Holding Shaft	QMN2064	1	
M108	Spring Washer	XWA3B	1	COMMON
M109	Nut 3ϕ	XNG3BS	1	"
M110	Stopper	QMF1698	1	RS-676US
M111	Flywheel	QXF0096A	1	"
M112	Flywheel Retainer	QXM0142	1	"
M113	Eject Lever Angle Assembly	QXA0300	1	"
M114	Eject Lever Arm Assembly	QXL0835	1	"
M115	Pause Rod Spring	QBT1751M	1	"
M116	Eject Lever	QML2693	1	"
M117	Eject Lever Spring	QBN1377	1	"
M118	Step Screw	QHQ1188S	1	
M119	Screw $\oplus 2 \times 6$	XSN2+6FX	1	COMMON
M120	Spring Hanger	QMF1808	1	
M121	Collar	QMC0032	1	
M122	Idler Arm Spring	QBT1191M	2	
M123	Safety Lever	QML2908	1	
M124	Lock Lever	QML2907	1	
M125	Stopper	QBG1132	1	RS-741US
M126	Switch Base Plate Assembly	QXK1693	1	
M127	Tapping Screw	XTN3+6	4	COMMON
M128	Stop Shaft	QMN2066	1	
M129	Push Button Spring	QBC1178	1	RS-676US
M130	Lock Plate	QML2909A	1	
M131	Lock Plate Assembly	QXL0986	5	
M132	Plunger Angle Assembly	QXA0456	1	

Ref. No.	Description	Part No.	Per Set (Pcs.)		Note
M133	Stop Lever	QML2910	1		
M134	Plunger (Auto Stop)	QME0129C	1		RS-817S
M135	Spring (for Plunger)	QBC1148	1		
	<u>RESISTORS</u>				
R1, 109, 110, 218	Carbon Resistor 47K Ω 1/8W	ERD18TJ473	4		
R2, 228	" 68K Ω 1/8W	ERD18TJ683	2		
R3, 4, 305, 306	" 10 Ω 1/8W	ERD18TJ100	4		
R5, 6, 23, 24, 157, 158, 317	" 100K Ω 1/8W	ERD18TJ104	7		
R7, 8, 33, 34	" 4.7K Ω 1/8W	ERD18TJ472	4		
R9, 10, 137, 138, 173, 174	" 220K Ω 1/8W	ERD18TJ224	6		
R11, 12	" 150K Ω 1/8W	ERD18TJ154	2		
R13, 14, 17, 18	" 18K Ω 1/8W	ERD18TJ183	4		
R15, 16, 29, 30	" 100 Ω 1/8W	ERD18TJ101	4		
R19, 20, 153, 154, 177, 178	" 56 Ω 1/8W	ERD18TJ560	6		
R21, 22	" 6.8K Ω 1/8W	ERD18TJ682	2		
R25, 26, 219	" 12K Ω 1/8W	ERD18TJ123	3		
R27, 28	" 1.8K Ω 1/8W	ERD18TJ182	2		
R31, 32, 129, 130, 143, 144, 210					
	" 3.9K Ω 1/8W	ERD18TJ392	7		
R35, 36	" 5.6K Ω 1/8W	ERD18TJ562	2		
R37, 127, 141, 155, 156, 217, 220					
	" 15K Ω 1/8W	ERD18TJ153	7		
R39, 40, 123, 124	" 270K Ω 1/8W	ERD18TJ274	4		
R41, 42, 83, 84	" 47K Ω 1/4W	ERD14VJ473	4		
R43, 44	" 18K Ω 1/4W	ERD14VJ183	2		
R45, 46, 47, 48, 203	" 390 Ω 1/8W	ERD18TJ391	5		
R49, 50, 165, 166, 205, 206, 221, 222, 224, 229, 322, 326, 327, 328, 329, 330, 331					
	" 10K Ω 1/8W	ERD18TJ103	17		
R51, 52, 303, 304	" 82K Ω 1/8W	ERD18TJ823	4		
R53, 54, 75, 76, 105, 106	" 120K Ω 1/4W	ERD14VJ124	6		
R55, 56	" 22K Ω 1/4W	ERD14VJ223	2		
R57, 58	" 8.2K Ω 1/8W	ERD18TJ822	2		
R59, 60, 85, 86	" 3.3K Ω 1/4W	ERD14VJ332	4		
R61, 62, 79, 80, 101, 102	" 33K Ω 1/4W	ERD14VJ333	6		

Ref. No.	Description	Part No.	Per Set (Pcs.)	Note
R63, 64	Carbon Resistor 82K Ω 1/4W	ERD14VJ823	2	
R65,66,163,164	" 120K Ω 1/8W	ERD18TJ124	4	
R67, 68, 69, 70, 73, 74, 95, 96, 119, 120				
	" 15K Ω 1/4W	ERD14VJ153	10	
R71, 72	" 560 Ω 1/4W	ERD14VJ561	2	
R77,78,113,114	" 1K Ω 1/4W	ERD14VJ102	4	
R81,82,121,122	" 270K Ω 1/4W	ERD14VJ274	4	
R87, 88	" 56K Ω 1/4W	ERD14VJ563	2	
R89,90,111,112	" 2.7K Ω 1/4W	ERD14VJ272	4	
R91, 92	" 1.8M Ω 1/4W	ERD14VJ185	2	
R93, 94	" 1M Ω 1/4W	ERD14VJ105	2	
R97,98,99,100,107,108	" 8.2K Ω 1/4W	ERD14VJ822	6	
R103, 104	" 10K Ω 1/4W	ERD14VJ103	2	
R115, 116	" 33 Ω 1/8W	ERD18TJ330	2	
R117, 118	" 47 Ω 1/8W	ERD18TJ470	2	
R125, 126	" 220K Ω 1/4W	ERD14VJ224	2	
R131, 132, 133, 134, 315, 323	" 1K Ω 1/8W	ERD18TJ102	6	
R135, 136, 171, 172, 201, 209, 314, 320, 321, 324, 401, 402				
	" 2.2K Ω 1/8W	ERD18TJ222	12	
R139, 140	" 39K Ω 1/8W	ERD18TJ393	2	
R145, 146, 151, 152, 311, 312	" 560 Ω 1/8W	ERD18TJ561	6	
R147, 148, 149, 150	" 4.7 Ω 1/8W	ERD18TJ4R7	4	
R159, 160	" 180K Ω 1/8W	ERD18TJ184	2	
R161, 162, 223	" 1K Ω 1/4W	ERD14TJ102	3	
R167, 168, 318	" 1.5K Ω 1/4W	ERD14TJ152	3	
R169, 170, 325	" 3.3K Ω 1/8W	ERD18TJ332	3	
R175, 176	" 27K Ω 1/8W	ERD18TJ273	2	
R179, 180	" 330 Ω 1/4W	ERD14VJ331	2	
R181, 182	" 330 Ω 1/8W	ERD18TJ331	2	
R202, 226	Metal Oxide Resistor SAFETY 22 Ω 5W	ERX5ANJ220	2	
R204, 211	Carbon Resistor SAFETY 220 Ω 1/8W	ERD18TJ221	2	
R207	Metal Oxide Resistor SAFETY 39 Ω 5W	ERX5ANJ390	1	
R208	" 56 Ω 1W	ERG1ANJ560	1	
R212	Solid Resistor 100 Ω 1/2W	ERC12GK101	1	
R213, 216	Carbon Resistor 22K Ω 1/4W	ERD14TJ223	2	

Ref. No.	Description	Part No.	Per Set (Pcs.)	Note
R214	Carbon Resistor 15 K Ω 1/4W	ERD14TJ153	1	
R215	" 150 Ω 1/4W	ERD14TJ151	1	
R225	" 220 Ω 1/4W	ERD14TJ221	1	
R227, 309	" 120 Ω 1/8W	ERD18TJ121	2	
R307	" 330 Ω 1/4W	ERD14TJ331	1	
R313, 319	" 22 K Ω 1/8W	ERD18TJ223	2	
R316	" 56 K Ω 1/8W	ERD18TJ563	1	
R403, 404	" 8.2 Ω 1/8W	ERD18TJ8R2	2	
<u>VARIABLE RESISTORS</u>				
VR1	Semi-fixed Variable Resistor 50 K Ω (B)	EVLS3AA00B54	1	
VR3, 4, 15, 16	" 5 K Ω (B)	EVLS3AA00B53	4	
VR5, 6	" 20 K Ω (B)	EVLS3AA00B24	2	
VR7, 8	Variable Resistor 50 K Ω (A)	EWKN5AR20A54	1	
VR9, 10	" 100 K Ω (A)	EWKN5AR20A15	1	
VR11, 12	Semi-fixed Variable Resistor 20 K Ω (B)	EVLS0AA00B24	2	
VR13, 14	" 500 Ω (B)	EVNJ0AA00B52	2	
VR17, 18	" 10 K Ω (B)	EVLS3AA00B14	2	
VR19, 20	Variable Resistor 10 K Ω (A)	EWKD1AK25A14	1	
VR21, 22	Semi-fixed Variable Resistor 500 K Ω (B)	EVLS3AA00B55	2	
VR301, 302	" 100 K Ω (B)	EVLS3AA00B15	2	
VR303	" 500 Ω (B)	EVLS3AA00B52	1	
<u>CAPACITORS</u>				
C1, 2	Styrol Capacitor 680 pF	ECQS1681JZ	2	
C3, 4, 53, 54	Electrolytic Capacitor 47 μ F	ECEA10V47L	4	
C5, 6, 21, 22	" 4.7 μ F	ECEA25M4R7L	4	
C7, 8	Ceramic Capacitor 0.001 μ F	ECKD1H102PF	2	
C9, 10, 29, 30, 83, 84	Electrolytic Capacitor 100 μ F	ECEA6V100L	6	
C11, 12, 204	" 47 μ F	ECEA6V47L	3	
C13, 14, 305	Mylar Capacitor 0.033 μ F	ECQM05333KZ	3	
C15, 16, 17, 18, 91, 92	" 0.0012 μ F	ECQM05122KZ	6	
C19, 20, 39, 40, 49, 50, 55, 56, 61, 62, 67, 68, 69, 70, 208, 212, 213, 216, 317, 318	Electrolytic Capacitor 10 μ F	ECEA16V10L	20	
C23, 24, 97, 98	Mylar Capacitor 0.012 μ F	ECQM05123KZ	4	

Ref. No.	Description	Part No.	Per Set (Pcs.)	Note
C25, 26	Electrolytic Capacitor	3.3 μ F	ECEA25M3R3L	2
C27, 28, 201, 202, 206	"	4.7 μ F	ECEA25V4R7L	5
C31, 32, 207, 315, 319	"	3.3 μ F	ECEA25V3R3L	5
C33, 34	Ceramic Capacitor	470 pF	ECKD1H471K	2
C35, 36	"	180 pF	ECKD1H181K	2
C37, 38, 41, 42, 79, 80, 215	Electrolytic Capacitor	10 μ F	ECEA25V10L	7
C43, 44	Mylar Capacitor	0.0056 μ F	ECQM05562JZ	2
C45, 46	"	0.0047 μ F	ECQM05472JZ	2
C47, 48	"	0.027 μ F	ECQM05273JZ	2
C51, 52, 57, 58	Electrolytic Capacitor	0.1 μ F	ECEA50ZR1	4
C59, 60	"	0.33 μ F	ECEA50ZR33K	2
C63, 64, 65, 66	"	0.1 μ F	ECEA50ZR1K	4
C71, 72	"	0.68 μ F	ECEA50ZR68	2
C73, 74	Mylar Capacitor	0.056 μ F	ECQM05563KZ	2
C75, 76	"	0.039 μ F	ECQM05393KZ	2
C77, 78	"	0.015 μ F	ECQM05153KZ	2
C81, 82, 209	Electrolytic Capacitor	33 μ F	ECEA25V33L	3
C85, 86	Mylar Capacitor	0.082 μ F	ECQM05823KZ	2
C87, 88, 320	Electrolytic Capacitor	1 μ F	ECEA50V1L	3
C89	Mylar Capacitor	0.01 μ F	ECQM05103KZ	1
C93, 94	Styrol Capacitor	470 pF	ECQS1471KZ	2
C95, 96	Electrolytic Capacitor	220 μ F	ECEA16V220L	2
C203	"	100 μ F	ECEA16V100L	1
C205	"	33 μ F	ECEA16V33M	1
C210	"	100 μ F	ECEA6V100L	1
C211	" SAFETY	3.3 μ F	ECEA25N3R3	1
C214	" SAFETY	2200 μ F	ECEB25V2200V	1
C217	"	330 μ F	ECEA6V330L	1
C301	Polypropylene Capacitor	0.027 μ F	ECQF4273JZH	1
C302	Mylar Capacitor	0.1 μ F	ECQM05104KZ	1
C303, 304	Styrol Capacitor	0.0047 μ F	ECQS1472KZ	2
C306, 308	Electrolytic Capacitor SAFETY	220 μ F	ECEA25V220VL	2
C309	" SAFETY	470 μ F	ECEA25V470VL	1
C310	" SAFETY	1000 μ F	ECEA25V1000A	1
C311	"	33 μ F	ECEA16V33L	1

Ref. No.	Description	Part No.	Per Set (Pcs.)	Note
C313	Electrolytic Capacitor 47 μ F	ECEA25Z47L	1	
C316	" 0.33 μ F	ECEA50ZR33	1	
C321, 322	Styrol Capacitor 220pF	ECQS1221KZ	2	
C401, 402, 403	Ceramic Capacitor 100pF	ECCD1H101K	3	
<u>TRANSISTORS</u>				
Tr1, 2	Transistor	2SA721	3	
Tr3, 4	"	2SC1327	2	RS-676US
Tr5, 6, 11, 12, 13, 30, 31, 32, 33, 34, 35, 36, 202, 206, 210, 307, 308				
	"	2SC828	29	"
Tr7, 8	"	2SC644	2	"
Tr9, 10, 201, 209, 301, 302	"	2SC1384	6	"
Tr17, 18	FET	2SK30AD	2	RS-263AUS
Tr21, 22, 205, 305, 306	Transistor	2SA564	5	RS-610US
Tr203, 208, 304	"	2SC1096ZKL	3	RS-676US
Tr204, 207	"	2SC1317	2	RS-451S
<u>DIODES & RECTIFIERS</u>				
D1, 2	Diode (Germanium)	OA90Z	2	COMMON
D3, 4, 5, 6	Diode (Silicon)	MA26W	4	RQ-444S
D7, 8, 13, 14, 201, 202, 203, 204, 206, 208, 214, 305				
	Diode (Germanium)	OA91	12	RS-676US
D9, 10	Diode (Silicon)	1S1211	2	"
D11, 12	"	1S1211L	2	
D209, 303	Rectifier (Silicon) SAFETY	10DC1	2	RS-676US
D210	" SAFETY	10DC1R	1	"
D211, 212, 213, 306, 307, 308, 309				
	Diode (Germanium)	OA90MLF	7	
D302	Diode (Silicon)	EQA0119R	1	
D304	"	MA150	1	RQ-454S
D205, 207, 215	"	SIB0102	3	RS-610US
<u>TRANSFORMERS</u>				
T1, 2	Headphone Transformer	QLT2D10A	2	
T201	Power Transformer SAFETY	QLPP5ELHA	1	

Ref. No.	Description	Part No.	Per Set (Pcs.)	Note
T301	Ossillator Transformer	QLB0158	1	RS-271US
	<u>COILS</u>			
L1, 2	Low Pass Filter	QLH2021A	2	RS-610US
L3, 4, 5, 6	Peaking Coil (3mH)	QLQX0331W	4	RS-676US
L7, 8	Peaking Coil (7mH)	QLQX0731W	2	"
	<u>COMBINATION PART</u>			
Z1	Spark Killer SAFETY	QCR0002T	1	
	<u>SWITCHES</u>			
S1, 2	Slide Switch (Record/Playback Selector)	QSS7203	2	
S3, 7	Push Switch (Bias, Equalization)	QSW2204W	2	
S5, 6	Push Switch (Dolby NR)	QSW6201W	2	
S8, 9, 209	Push Switch (Peak Check, Memory)	QSW2203W	3	
S201, 202	Micro Switch (Power Supply, Erase Safety)	QSM0040A	2	RS-676US
S203, 204, 206	Push Switch (Rewind, F.F, Record)	QSW2205W	3	
S205	Push Switch (Playback)	QSW4202W	1	
S207	Push Switch (Pause)	QSW2206W	1	
S208	Tape Counter Switch	Refer to M101	(1)	
S210	Reed Switch (Tape End Detector)	QSE0003	1	
S211	Push Switch (Power ON/OFF)	ESB1134SU	1	RS-676US
	<u>JACKS</u>			
J1, 2, 5, 6	Jack Board Assembly (LINE IN, LINE OUT)	QEJ0346	4	
J3, 4	Microphone Jack	QJA0248	2	
J8	Headphone Jack	QJA0247	1	
	<u>ELECTRICAL PARTS</u>			
E1	Record/Playback Head	WY445AZA	1	RS-676US
E2	Erase Head	QWY2118	1	RS-610US
E3	Level Meter	QSL1063RNM	2	
E4	Pilot Lamp	XAMR9S	3	RS-676US
E5	Pilot Lamp Holder	QTF1052	3	"
E6	AC Power Cord SAFETY	RJA10A	1	RD Supply

Ref. No.	Description	Part No.	Per Set (Pcs.)	Note
E7	Cord Bushing	QTD1129	1	RS-676US
E8	Pilot Lamp (Record)	XAMQ34S200W	1	
E9	Heat Sink	QTH1088A	1	
E10	6P Socket	QJS0754	3	RS-676US
E11	Spark Killer Cover	SAFETY QTW1118A	1	
E12	Plunger Holding Plate	QMF1791	1	
E13	Plunger (Record)	QME0128A	1	RS-676US
E14	Plunger Pin	QMN1818	1	"
E15	Meter Cover	QKJ0107	1	
E16	Headphone Jack Nut	QNQ1051	3	RS-676US
<u>CABINET PARTS</u>				
G1	Case Cover	QGC1040	1	RS-676US
G2	Bottom Cover Assembly	QYB0367B	1	
G2-1	Rubber Foot	QKA1065	4	RS-676US
G2-2	Screw $\oplus 4 \times 3$	XSN4+8FXS	4	COMMON
G3	Front Panel Assembly	QYP0572	1	
G3-1	Cassette Lid Assembly	QYF0155	1	RS-676US
G3-2	Cassette Lid Holder	QXA0289	1	"
G3-3	Cassette Lid Retainer	QMF1687A	2	
G3-4	Lock Spring	QBP1577A	1	
G3-5	Lock Piece	QKJ0047	1	
G3-6	Lock Guide	QGG0045	1	
G3-7	Push Button Spring	QBC1275	5	
G3-8	Push Button Assembly	QXB0351	5	
G3-9	Control Button Shaft	QMN2065	1	
G3-10	Control Button Spring	QBN1474	6	
G3-11	Control Button (Record)	QXB0370	1	
G3-12	Control Button (Rewind)	QGO1232	1	
G3-13	Control Button (Fast Forward)	QGO1231	1	
G3-14	Control Button (Playback)	QGO1229	1	
G3-15	Control Button (Stop)	QGO1228	1	
G3-16	Control Button (Pause)	QGO1230	1	
G3-17	Spacer	QBH0132	1	
G3-18	Button Holding Plate	QMF1790	1	

Ref. No.	Description	Part No.	Per Set (Pcs.)	Note
G3-19	Screw $\oplus 2 \times 4$	XTB2+4BFC	9	COMMON
G3-20	Screw $\oplus 2 \times 5$	XTB2+5BFC	2	"
G3-21	Washer	XWG2BC	2	"
G3-22	Screw $\oplus 3 \times 8$	XTS3+8BFX	2	"
G3-23	Snap Washer	QWQ1124	1	RS-676US
G4	Jack Base Plate	QMK1559	1	
G5	Cassette Cover Assembly	QYR0152	1	RS-676US
G6	Head Cover Assembly	QYR0153	1	"
G7	Eject Lever-A Assembly	OXL0816	1	
G8	Eject Lever Cap	QKJ0048A	1	RS-676US
G9	Eject Lever-B Assembly	OXL0817	1	
G10	Eject Button Assembly	QXB0232	1	RS-676US
G11	Eject Button Spring	QBC1178	1	"
G12	Volume Knob-A Assembly	QYT0378	2	
G13	Nylon Washer	QBJ3229	2	
G14	Volume Knob-B Assembly	QYT0379	2	
G15	Volume Knob	QGT1264K	1	RS-676US
G16	Screw $\oplus 4 \times 8$	XSB4+8FZS	4	COMMON
G17	Washer	XWJ4FZ	4	"
G18	Screw $\oplus 3 \times 6$	XYN3+C6FXS	2	"
G19	Washer	XWG3	2	"
G20	Screw $\oplus 3 \times 8$	XTN3+8BFZ	4	"
G21	Screw $\oplus 4 \times 8$	XTB4+8BFR	8	"
G22	Screw $\oplus 3 \times 6$	XSB3+6FXS	6	"
G23	Washer	XUC25FT	3	"
G24	"	QBJ3216	3	RS-676US
G25	Fiber Washer	QBJ3215	2	"
G26	Push Button Assembly	QBK7126	1	RQ-832S
G27	Push Button Assembly	QYT0114H1	1	RS-676US
G28	Eject Button Shaft	QMN1842	1	"
G29	Name Plate	QGS1983	1	
	<u>ACCESSORIES</u>			
A1	Connection Cord	RP023A	2	RS-676US
A2	Instruction Book	OQT0960	1	

#3