

Service Manual

Cassette Deck

RS-B55 RS-955

dbx/Dolby B-C NR
Stereo Cassette Deck

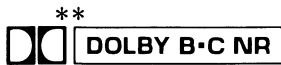

- The photographs show RS-955 model.
- The function and operating method of RS-955 are the same as for RS-B55.

RS-B55 MECHANISM SERIES (For U.S.A.)

RS-B25 MECHANISM SERIES (For other areas.)

SPECIFICATIONS

Deck system	Stereo cassette deck
Track system	4-track, 2-channel
Heads REC/PLAY	AX (Amorphous) head
Erasing	Double-gap ferrite head
Motor	1 motor
Recording system	AC bias
Bias frequency	80 kHz
Erasing system	AC bias
Tape speed	4.8 cm/sec. (1 7/8 ips)
Frequency response	
Metal	20 Hz~19,000 Hz 30 Hz~18,000 Hz (DIN) 40 Hz~17,000 Hz ±3 dB
CrO₂	20 Hz~18,000 Hz 30 Hz~17,000 Hz (DIN) 40 Hz~16,000 Hz ±3 dB
Normal	20 Hz~17,000 Hz 30 Hz~16,000 Hz (DIN) 40 Hz~15,000 Hz ±3 dB
Dynamic Range (with dbx in)	110 dB (1 kHz)
S/N (signal level=max. recording level, CrO₂ type tape)	
dbx in	92 dB (A weighted)
Dolby C NR in	75 dB (CCIR)
Dolby B NR in	67 dB (CCIR)
NR out	57 dB (A weighted)

Wow and flutter	0.07% (WRMS) ±0.13% (DIN)
Max. Input Level Improvement (with dbx in)	10 dB (1 kHz)
Fast Forward and Rewind Time	Approx. 90 seconds with C-60 cassette tape
Input sensitivity and impedance	
MIC	0.25 mV/400Ω-10 kΩ
LINE	60 mV/47 kΩ
Output voltage and impedance	
LINE	400 mV/1.5 kΩ
HEADPHONES	80 mV/8Ω
Power consumption	18 W
Power supply	[M] AC; 120V, 60 Hz [E][EH][EGA] AC; 220V, 50 Hz/60 Hz [EK][XA][XL] AC; 110V/127V/220V/240V, 50 Hz/60 Hz Preset power voltage 240V
Dimensions (W×H×D)	430×99.5×229 mm (16-29/32"×3-29/32"×9")
Weight	3.5 kg (7 lbs 11 oz)

Color	Area
(K)	[M] U.S.A. (RS-955)
(K) (S)	[E] All European areas except United Kingdom. (RS-B55)
(K) (S)	[EK] United Kingdom. (RS-B55)
(K) (S)	[EH] Holland. (RS-B55)
(K) (S)	[EGA] .. F.R.Germany. (RS-B55)
(K) (S)	[XA] Asia, Latin America, Middle East and Africa. (RS-B55)
(K) (S)	[XL] Australia. (RS-B55)

Color

(K)... Black Type
(S)... Silver Type

Design and specifications are subject to change without notice.

* The term dbx is a registered trademark of dbx Inc.

** 'Dolby' and double-D symbol are trademarks of Dolby Laboratories Licensing Corporation.

Technics

Matsushita Engineering and Service Company
50 Meadowland Parkway,
Secaucus, New Jersey 07094

Panasonic Sales Company, Division of Matsushita Electric of Puerto Rico, Inc.
Ave. 65 De Infanteria, KM 9.7
Victoria Industrial Park
Carolina, Puerto Rico 00630

Panasonic Hawaii Inc.
91-238 Kauhū St. Ewa Beach
P.O. Box 774
Honolulu, Hawaii 96808-0774

Matsushita Electric Trading Co., Ltd.
P.O. Box 288, Central Osaka Japan

CONTENTS

	Page		Page
Location of Controls	2	Schematic Diagram	24~28
Safety Precaution	3	Circuit Boards and Wiring Connection Diagram	29~32
Operations	3~5	Terminal Guide of Transistors, Diodes, Coils and IC's	33
Disassembly Instructions	6, 7	Cabinet Parts Location	33~35
Measurements and Adjustments	8~12	Mechanical Parts Location	36~38
Microcomputer Terminal Function and Waveform	13~18	Technical Guide	39, 40
Block Diagram	19~21		
Electrical Parts List	22, 23		

LOCATION OF CONTROLS

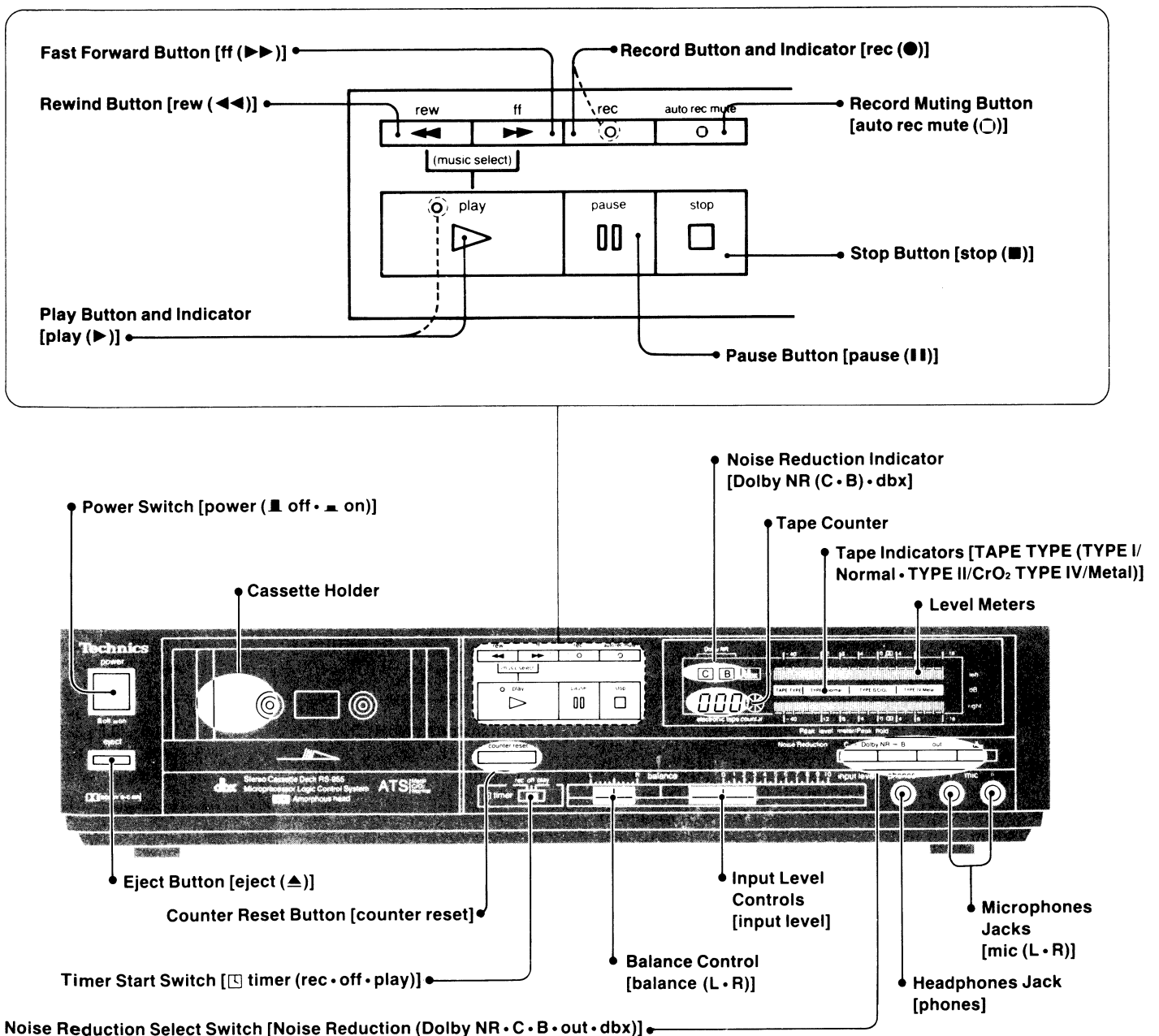

Cassette Deck

DEUTSCH

Verwenden Sie bitte diese Broschüre Zusammen mit der Service-Anleitung für das Modell Nr. RS-B55.

TECHNISCHE DATEN

System	Stereo-Cassettendeck
Spuren	4 Spuren, 2 Kanäle
Tonköpfe	
Aufnahme/Wiedergabe	AX-Kopf
Löschen	Ferrit-Kopf mit Doppelspalt
Motor	1-Motor
Aufnahmesystem	Wechselstrom-Vormagnetisierung
Vormagnetisierungsfrequenz	80 kHz
Löschsystem	Wechselstrom-Vormagnetisierung
Bandgeschwindigkeit	4,8 cm/s
Frequenzgang	
Reineisenbänder	20 Hz~19.000 Hz 30 Hz~18.000 Hz (DIN) 40 Hz~17.000 Hz±3 dB
CrO₂-Bänder	20 Hz~18.000 Hz 30 Hz~17.000 Hz (DIN) 40 Hz~16.000 Hz±3 dB
Normalbänder	20 Hz~17.000 Hz 30 Hz~16.000 Hz (DIN) 40 Hz~15.000 Hz±3 dB
Dynamischer Bereich (mit dbx-Rauschunterdrückung)	110 dB (1 kHz)

Geräuschspannungsabstand:

(Signalpegel = max. Aussteuerungspegel, CrO ₂ -Band)	
mit dbx-Rauschunterdrückung	92 dB (nach Abwertef)
mit Dolby C-Rauschunterdrückung	75 dB (CCIR)
mit Dolby B-Rauschunterdrückung	67 dB (CCIR)
ohne Rauschunterdrückung	57 dB (nach A bewertet)
Gleichschwankungen	0,07% (WRMS) ±0,13% (DIN)
Max. Eingangspegelverbesserung (mit dbx)	10 dB (1kHz)
Umspulzeit	ca. 90 s für C-60-Cassette
Eingangsempfindlichkeit und Impedanz	
MIC	0,25 mV/400 Ω~10 kΩ
LINE	60 mV/47 kΩ
Ausgangsspannung und Impedanz	
LINE	400 mV/1,5 kΩ
HEADPHONES	80 mV/8 Ω
Stromaufnahme	18 W
Stromversorgung	Netz 50 Hz/60 Hz, 220 V für Europa ohne England.
Abmessungen (B×H×T)	430×99,5×229 mm
Gewicht	3,5 kg

MESSUNGEN UND EINSTELL METHODEN

Anm.: Wenn nicht anders vorgeschrieben, Drehschalter und Steuereinrichtungen auf die folgenden Positionen stellen.

- Für saubere Köpfe sorgen.
- Für saubere Tonwelle und Andruckrolle sorgen.
- Auf normale Raumtemperatur achten: 20±5°C (68±9°F)
- Dolby-Schalter: AUS
- Abgleichkontrolle: Mitte (Zentrum)
- Bandsortenschalter: NORMAL
- Eingangswahlschalter: LINE
- Eingangsregler: MAX

A Senkrechtstellen des Kopfes

Bedingung:
• Wiedergabe

Meßgerät:

- Elektronische Voltmeter
- Oszillograph
- Testband (azimuth)...QZZCFM

Ausgangsbalance-Justierung für linken und rechten Kanal

1. Den Meßaufbau zeigt Fig. 2.

2. 8kHz-Signal des Testbandes (QZZCFM) wiedergeben.

Schraube (B) in Fig. 3 auf maximalen Ausgangspegel des linken und rechten Kanals abgleichen.

Sind die Ausgangspegel des linken und rechten Kanals nicht gleichzeitig maximal, wie folgt justieren:

3. Durch Drehen der in Fig. 3 gezeigten Schraube (B) die Winkel A und C (Punkte, wo Spitzenausgangspegel für den linken und rechten Kanal erreicht werden) ermitteln. Anschließend den Winkel B zwischen dem Winkel A und C ermitteln, d.h. den Punkt, wo die Ausgangspegel des linken und rechten Kanals ausbalanciert (ausgeglichen) sind. (Siehe Fig. 3 und 4.)

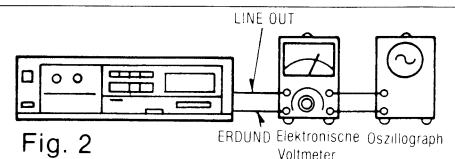

Fig. 2

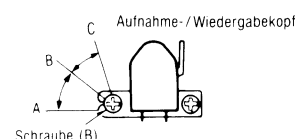

Fig. 3

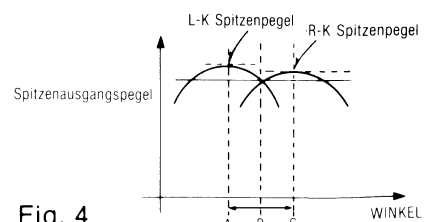

Fig. 4

Phasenjustierung für linken und rechten Kanal

- Den Meßaufbau zeigt Fig. 5.
- 8kHz-Signal des Testbandes (QZZCFM) wiedergeben. Schraube (B), wie in Fig. 3 gezeigt, so einstellen, so daß Zeiger von zwei Röhrevoltmeter auf Maximum ausschlagen und am Oszillographen eine Wellenform wie in Fig. 6 erreicht wird.

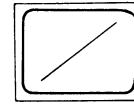
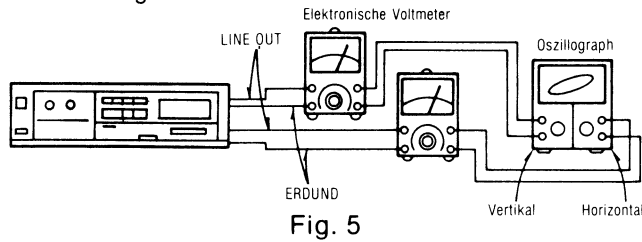

Fig. 6

ⓐ Bandgeschwindigkeit

Bedingung:
• Wiedergabe

Meßgerät:
• Elektronischer Digitalzähler
• Testband...QZZCWAT

Genauigkeit der Bandgeschwindigkeit

- Den Meßaufbau zeigt Fig. 7.
- Testband (QZZCWAT 3000Hz) wiedergeben und Ausgangssignal dem Zähler zuführen.
- Frequenz messen.
- Beträgt die auf dem Testband aufgezeichnete Frequenz 3000Hz, so ergibt sich die Genauigkeit nach folgender Formel:

$$\text{Genauigkeit der Bandgeschwindigkeit} = \frac{f-3000}{3000} \times 100(\%)$$

worin f die gemessene Frequenz ist.

- Die Messung soll im mittleren Teil des Bandes erfolgen.

NORMALWERT: 0,33% (3000±10Hz)

- Falls der Meßwert nicht im vorgeschriebenen Bereich liegt, bitte mit Bandgeschwindigkeitsregler VR wie in Fig. 1 gezeigt einstellen.

Anmerkung: Bitte bei dieser Einheit zum Justieren der Bandgeschwindigkeit keinen Metallschraubenzieher benutzen.

Schwankung der Bandgeschwindigkeit:

Messung, wie oben beschrieben für Anfang, mittleren Teil und Ende des Testbandes wiederholen und Schwankung wie folgt bestimmen:

$$\text{Schwankung} = \frac{f_1 - f_2}{3000} \times 100(\%)$$

f_1 = Maximalwert

f_2 = Minimalwert

NORMALWERT: 1%

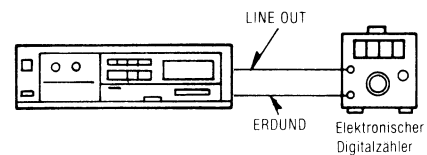

Fig. 7

ⓐ Frequenzgang bei Wiedergabe

Bedingung:
• Wiedergabe

Meßgerät:
• Elektronische Voltmeter
• Oszillograph
• Testband...QZZCFM

- Den Meßaufbau zeigt Fig. 2.
- Gerät auf Wiedergabe schalten. Frequenzgang-Testband QZZCFM wiedergeben.
- Ausgangsspannung bei 315Hz, 12,5kHz, 8kHz, 1kHz, 250Hz, 125Hz und 63Hz messen und jede Ausgangsspannung mit der Standardfrequenz 315Hz an der LINE OUT vergleichen.
- Messungen an beiden Kanälen durchführen.
- Prüfen, ob die gemessenen Werte innerhalb des in der Frequenzgang-Übersicht aufgeführten Bereichs liegen. (Siehe Fig. 8.)

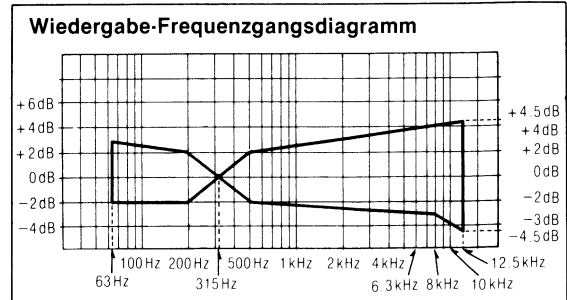

Fig. 8

ⓓ Wiedergabe-Verstärkung

Bedingung:
• Wiedergabe

Meßgerät:
• Elektronische Voltmeter
• Oszillograph
• Testband...QZZCFM

1. Den meßaufbau zeigt Fig. 2.
2. Den Standard-Aufnahmepegelteil der Testbandcassette (QZZCFM, 315 Hz) wiedergeben und mit dem Elektronische Voltmeter den Ausgangspegel an den LINE OUT-Anschlüssen messen.
3. Messung an beiden Kanälen durchführen.

NORMALWERT: 0,4V±0,5dB (0,02V)

Einstellung:

1. Abweichungen können durch Abgleich von VR5 (linker Kanal) und VR6 (rechter Kanal), korrigiert werden.
2. Nach erfolgtem Abgleich ist der Frequenzgang bei Wiedergabe erneut zu kontrollieren.

ⓔ Löschstrom

Bedingung:
• Aufnahme

Meßgerät:
• Elektronische Voltmeter
• Oszillograph
• Testband (Leerband)...QZZCRZ für Metall

1. Den Meßaufbau zeigt Fig. 9.
2. Die Aufnahme- und Pausentaste drücken.
3. Das Metallband-Referenzleerband (QZZCRZ) einsetzen.
4. Löschstrom nach folgender Formel ermitteln:

$$\text{Löschstrom (A)} = \frac{\text{Die Spannung über beide Enden von R301}}{1 \text{ (Ohm)}}$$

NORMALWERT: 155±15mA (Metal position) (155±15mV)

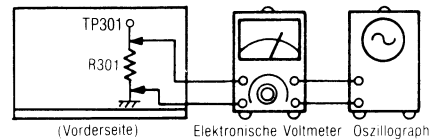

Fig. 9

5. Falls der Meßwert nicht im vorgeschriebenen Bereich liegt, auf folgenden Weise einstellen.

Einstellung:

1. Die Punkte (A) und (B) der Hauptschaltplatte kurzschließen.
2. Den Löschstrom messen.
3. Beträgt der Löschstrom weniger als 140 mA, den Punkt (B) kurzschließen.
4. Beträgt der Löschstrom mehr als 170 mA: Punkt (A) unterbrechen.

ⓕ Gesamtfrequenzgang

Bedingung:
• Aufnahme und Wiedergabe
• Eingangsgregler...MAX

Meßgerät:
• Elektronische Voltmeter
• NF-Generator
• Abschwächer
• Oszillograph
• Testband (Leerband)
...QZZCRA für Normal
...QZZCRX für CrO₂
...QZZCRZ für Metall
• Widerstand (600Ω)

Anm.:

Vor Messung und Abgleich des Gesamtfrequenzganges ist sicherzustellen, daß der Frequenzgang bei Wiedergabe korrekt ist (Vgl. entspr. Abschnitt).

Gesamtfrequenzgangs-Justierung durch Aufnahme-Vomagneti-sierungsstrom

(Der Aufnahme-Entzerrer ist fest eingestellt.)

1. Den Meßaufbau zeigt Fig. 11.
2. Das Normalband-Referenzleerband (QZZCRA) einsetzen.
3. An LINE IN ein Signal von 1kHz, -24dB zuführen. Das Gerät auf Aufnahme schalten.
4. Den Dämpfungswiderstand feineinstellen, bis die Ausgangsleistung an LINE OUT 0,4V beträgt.
• Überprüfen, daß der Signalausgangspegel bei einer Ausgangs-Spannung von 0,4V -24±4dB beträgt.
5. Mit dem NF-Oszillator Signale von 50Hz, 100Hz, 200Hz, 500Hz, 1kHz, 4kHz, 8kHz, 10kHz und 12,5kHz zuführen, und diese Signale auf das Testband aufzeichnen.

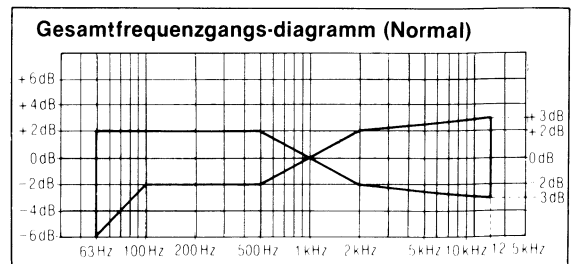

Fig. 10

6. Die in Schritt 5 aufgezeichneten Signale wiedergeben und überprüfen, ob die Frequenzgangkurve innerhalb des Bereichs liegt, der im Frequenzgangdiagramm für normales Band in Fig. 10 gezeigt ist. (Falls die Kurve innerhalb des vorgeschriebenen Bereichs liegt, mit den Schritten 7, 8 und 9 weiterfahren.)
Falls die Kurve außerhalb des vorgeschriebenen Bereichs liegt, wie folgt justieren.

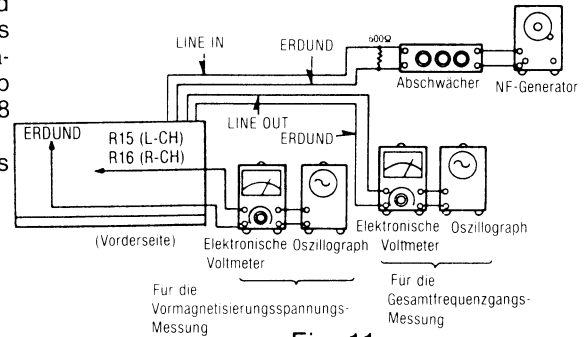

Fig. 11

Justierung (A):

Wenn die Kurve den vorgeschriebenen Gesamtfrequenzgangbereich (Fig. 10) überschreitet, wie in Fig. 12 gezeigt.

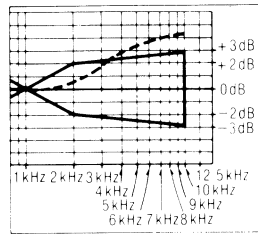

Fig. 12

- 1) Den Vormagnetisierungsstrom durch Abgleichen von VR301 (linker Kanal) und VR302 (rechter Kanal) erhöhen.
- 2) Die Schritte 5 und 6 zur Überprüfung wiederholen. (Wenn die Kurve dabei innerhalb des vorgeschriebenen Bereichs liegt (Fig. 10) mit den Schritten 7, 8, und 9 weiterfahren.)
- 3) Wenn die Kurve den vorgeschriebenen Bereich (Fig. 10) noch immer überschreitet, den Vormagnetisierungsstrom weiter erhöhen, und die Schritte 5 und 6 wiederholen.

Justierung (B):

Wenn die Kurve unter den vorgeschriebenen Bereich für den Gesamtfrequenzgang (Fig. 10) absinkt, wie in Fig. 13 gezeigt:

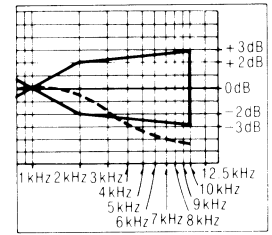

Fig. 13

- 1) Den Vormagnetisierungsstrom durch abgleichen von VR301 (linker Kanal) und VR302 (rechter Kanal) reduzieren.
- 2) Die Schritte 5 und 6 zur Überprüfung wiederholen. (Falls die Kurve dabei innerhalb des vorgeschriebenen Bereichs in Fig. 10 liegt, mit den Schritten 7, 8, und 9 weiterfahren.)
- 3) Falls die Kurve noch immer unter den vorgeschriebenen Bereich (Fig. 10) absinkt, den Vormagnetisierungsstrom weiter reduzieren, und Schritte 5 und 6 wiederholen.

7. Das CrO₂ Band-Referenzleerband (QZZCRX) einsetzen.
8. Testband QZZCRX einlegen, und Signale von 50Hz, 100Hz, 200Hz, 500Hz, 1kHz, 4kHz, 8kHz, 10kHz und 15kHz aufzeichnen; Anschliessend die Signale wiedergeben und prüfen, ob die Kurve innerhalb des Bereichs liegt, der im Gesamtfrequenzgang-Diagramm für das CrO₂ Band dargestellt ist. (Fig. 14.)
9. Das Metallband-Referenzleerband (QZZCRZ) einsetzen. Testband QZZCRZ einlegen und Signale von 50Hz, 100Hz, 200Hz, 500Hz, 1kHz, 4kHz, 8kHz, 10kHz und 15kHz aufnehmen. Anschliessend die Signale wiedergeben und prüfen, ob die Kurve innerhalb des Bereichs im Gesamtfrequenzgangdiagramm für Metallband liegt. (Fig. 14.)
10. Überprüfen, daß die Vorspannung ungefähr den folgenden Werten entsprechen, wenn der Bandsortenschalter in die entsprechende Position gestellt ist.

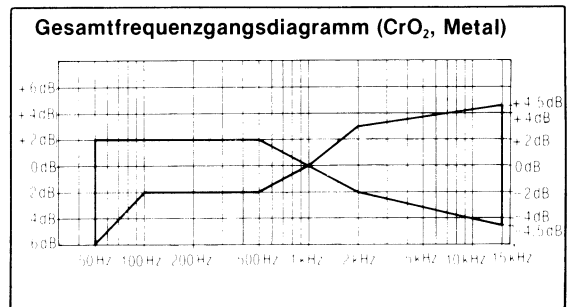

Fig. 14

- Die Spannung an den Anschlüssen des Widerstandes R15 (linker Kanal) [R16 (rechter Kanal)] ablesen und den Vormagnetisierungsstrom entsprechend folgender Formel berechnen.

$$\text{Vormagnetisierungsstrom (A)} = \frac{\text{Spannung am Elektronische Voltmeter (V)}}{10 (\Omega)}$$

Ungefähr 170 μA (Normal position)
Bezugswert: Ungefähr 200 μA (CrO₂ position)
Ungefähr 370 μA (Metall position)

© **Gesamtverstärkung**

Bedingung:

- Aufnahme und Wiedergabe
- Eingangsregler: MAX
- Standard-Eingangspegel:

Mikrofon -72 ± 5 dB
(0,25 mV)

NF-Eingang -24 ± 4 dB
(63 mV)

Meßgerät:

- Elektronische Voltmeter
- NF-Generator
- Abschwächer
- Oszillograph
- Widerstand (600Ω)
- Testband (Leerband)
 ...QZZCRA für Normal

1. Den Meßaufbau zeigt Fig. 15.
2. Das Normalband-Referenzleerband (QZZCRA) einsetzen.
3. Gerät auf "Aufnahme" schalten.
4. Über den Abschwächer ein 1kHz-Signal (-24dB) vom NF-Generator dem NF-Eingang zuführen.
5. ATT justieren, bis der Monitorpegel an den LINE OUT-Anschlüssen 0,4V beträgt.
6. Eine bespielte Cassette wiedergeben und überprüfen, ob der Ausgangspegel an den LINE OUT-Anschlüssen 0,4V beträgt.
7. Wenn der gemessene Wert nicht 0,4V erreicht, die folgenden VR abgleichen: VR103 (L-K) oder VR104 (R-K).
8. Ab Punkt 2 wiederholen.

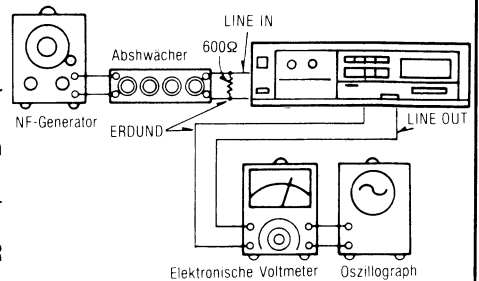

Fig. 15

Fluoreszenzmeter

Bedingung:

- Aufnahme
- Eingangsregler...MAX.

Meßgerät:

- Elektronische Voltmeter
- NF-Generator
- Abschwächer
- Oszillograph
- Widerstand (600Ω)

1. Der Anschluß des Prüfgerätes wird in Fig. 15 gezeigt.
2. Die Einheit auf Aufnahmestellung schalten.
3. Ein 1kHz Signal (-24dB) vom AF Oszillator durch "ATT" auf "LINE IN" geben.

Justierung auf -40 dB

4. Abschwächer so abstimmen, daß der in Stufe 3 abgestimmte Pegel um 40 dB vermindert wird.
5. Zu diesem Zeitpunkt prüfen, ob der -40 dB Anzeiger abgeschwächt leuchtet (mittelhell, zwischen ganz hell und erlischt: Siehe Fig. 16).
6. Wenn der Anzeiger nicht, wie in Stufe 6 beschrieben, abgeschwächt, leuchtet VR102 abstimmen.

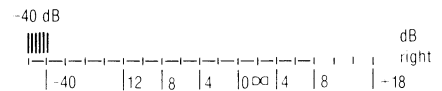

Fig. 16

Justierung auf 0 dB

7. Den Zustand von Stufe 3 herstellen. Ausgangspegel auf $0,4 V \pm 0,02 V$ an der LINE OUT festsetzen.
8. Zu diesem Zeitpunkt prüfen, ob der 0 dB Anzeiger abgeschwächt aufleuchtet (mittelhell, zwischen ganz hell und erlischt siehe Fig. 17).
9. Wenn nicht korrekt, VR201 abstimmen.
10. Einstellungen und Prüfungen der Stufen 3, 4, 5, 6, 7, 8 und 9 zweibis dreimal wiederholen.

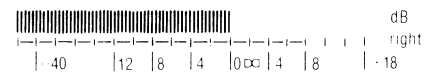

Fig. 17

Dolby-Schaltung

Bedingung:

- Aufnahme
- Dolby-Schalter ...IN/OUT (AN/AUS)
- Dolby-Wahlschalter ...B/C

- Eingangsregler...MAX.

Meßgerät:

- Elektronische Voltmeter
- NF-Generator
- Abschwächer
- Oszillograph
- Widerstand (600Ω)

Aufnahmeseite

- Überprüfung der Dolby-B-Typ Verschlüsselungsmerkmale.

1. Den Meßaufbau zeigt Fig. 18.
2. Gerät auf "Aufnahme" stellen. (Dolby-Wahlschalter ist OUT (AUS).)
3. Dem NF-Eingang ein 1kHz-Signal zuführen.
4. Abschwächer so abstimmen, daß die Ausgangsspannung an Nadel 7 von IC401 (L-K) und IC402 (R-K) $12,3mV$ beträgt.
5. Die Ausgangsspannung an Nadel 21 sollte $0dB$ betragen ($375mV$).
6. Den Dolby-Wahlschalter auf B stellen. Sicherstellen, daß das Ausgangssignalpegel an Nadel 21 von IC401 (L-K) und IC402 (R-K) $+6 dB \pm 1,5 dB$ beträgt ($753 mV$).
7. Dolby-Wahlschalter ausschalten und die Frequenz auf $5kHz$ abstimmen. Das Ausgangssignal an Nadel 21 sollte $0dB$ betragen ($375mV$).
8. Dolby-Wahlschalter auf B stellen und sicherstellen, daß das Ausgangssignalpegel an Nadel 21 von IC401 (L-K) und IC402 (R-K) $+8 dB \pm 1,5 dB$ beträgt ($948 mV$).

• Überprüfung der Dolby-C-Typ Verschlüsselungsmerkmale

1. Obige Stufen 1 bis 5 wiederholen.
2. Dolby-Wahlschalter auf C stellen und sicherstellen, daß das Ausgangssignalpegel an Nadel 21 von IC401 (L-K) und IC402 (R-K) $+11,5 \text{ dB} \pm 2 \text{ dB}$ beträgt (1,4 V).
3. Dolby-Wahlschalter ausschalten und die Frequenz auf 5kHz abstimmen.
Die Ausgangsspannung an Nadel 21 sollte 0dB sein (375mV).
4. Dolby-Wahlschalter auf C stellen und sicherstellen, daß das Ausgangssignalpegel an Nadel 21 von IC401 (L-K) und IC402 (R-K) $+8,5 \text{ dB} \pm 2 \text{ dB}$ beträgt (1 V).

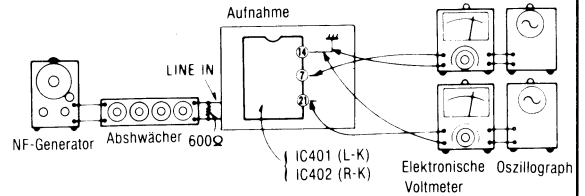

Fig. 18

① Einsatz Ausgleichszeit-Justierung (dbx Schaltung)

Bedingung:

- Betriebsart Aufnahme
- Eingangspegelregler...MAX
- Abgleichkontrolle ...Mitte (Zentrum)

Meßgeräte:

- Elektronische Voltmeter
- Dämpfungsglied
- AF-Oszillator
- Gleichstromvoltmeter
- Geräuschverminderungs-Schalter...dbx Band

1. Führen Sie die in Fig. 19 gezeigten Anschlüsse durch und geben Sie ein 1 kHz -27 dB Signal vom LINE IN ein und stellen Sie den Lärmreduktionswähler in die Position dbx.
2. Versetzen Sie das Gerät in die Betriebsart Aufnahme und stellen Sie das Dämpfungsglied so ein, daß der Signalpegel beim C541 (linker kanal) und beim C542 (rechter kanal) 300mV ist.
3. Voltzahl auf DC Voltmeter ablesen.

Bezugswert: $15 \pm 0,5 \text{ mV}$

4. Weicht der Meßwert vom Bezugswert ab, VR101 abgleichen.

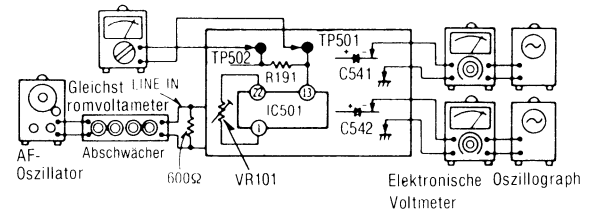

Fig. 19

FRANÇAIS

Ceci est à utiliser conjointement avec le manuel d'entretien du modèle No. RS-B55.

■ CARACTERISTIQUES

Platine	Platine magnéto-cassette stéréo
Pistes	4 pistes, 2 canaux
Têtes	
ENREGISTREMENT/LECTURE	Tête en AX
Effacement	Tête en ferrite à double entrefer
Moteur	1-moteur
Système d'enregistrement	Polarisation CA
Fréquence de polarisation	80 kHz
Système d'effacement	Polarisation CA
Vitesse de défilement de la bande	4,8 cm/sec.
Réponse en fréquence	
Métal	20 Hz~19.000 Hz
	30 Hz~18.000 Hz (DIN)
	40 Hz~17.000 Hz $\pm 3 \text{ dB}$
CrO₂	20 Hz~18.000 Hz
	30 Hz~17.000 Hz (DIN)
	40 Hz~16.000 Hz $\pm 3 \text{ dB}$
Normal	20 Hz~17.000 Hz
	30 Hz~16.000 Hz (DIN)
	40 Hz~15.000 Hz $\pm 3 \text{ dB}$
Portée dynamique (avec système dbx)	110 dB
Rapport signal/bruit:	
(niveau de signal = niveau d'enregistrement maximum, bande magnétique de type CrO ₂)	

Système dbx	92 dB (A pondéré)
Système de Dolby C	75 dB (CCIR)
Système de Dolby B	67 dB (CCIR)
Pas de système de NR	57 dB (A pondéré)
Pleurage et scintillement	0,07% (WRMS)
	$\pm 0,13\%$ (DIN)
Améoration du niveau d'entrée maximum (avec système dbx)	10 dB (1kHz)
Temps d'avance rapide et de rebobinage	Environ 90 secondes pour une cassette C-60
Sensibilité et impédance d'entrée	
MIC	0,25mV/400Ω~10 kΩ
LIGNE	60 mV/47 kΩ
Tension et impédance de sortie	
LIGNE	400 mV/1,5 kΩ
HEADPHONES	80 mV/8 Ω
Consommation	18 W
Alimentation	AC 50 Hz/60 Hz 220 V pour l'Europe sauf la Grande Bretagne.
Dimensions (L×H×P)	430×99,5×229 mm
Poids	3,5 kg

METHODES DES MESURES ET REGLAGES

REMARQUES: Placer les interrupteurs et les contrôles dans les positions suivantes, sauf indication contraire.

- Vérifier que les têtes soient propres.
- Vérifier que le cabestan et le galet presseur soient propres.
- Température ambiante admissible: $20 \pm 5^\circ\text{C}$
- Interrupteur de réduction de bruit: OUT
- Sélecteur de bande: Normal
- Sélecteur d'entrée: Line in
- Contrôles de niveau d'entrée: Maximum
- Contrôle de l'équilibre: Centre

<p>A Réglage de l'azimut de tête</p>	<p>Condition:</p> <ul style="list-style-type: none"> • Mode de lecture 	<p>Equipement:</p> <ul style="list-style-type: none"> • Voltmètre électronique • Oscilloscope • Bande étalon (azimut) ... QZZCFM
<p>Réglage de l'équilibre de la sortie au canal gauche/canal droit</p> <p>1. Brancher les appareils comme indiqué dans la Fig. 2.</p> <p>2. Reproduire le signal de 8kHz de la bande étalon (QZZCFM). Régler la vis (B) dans la Fig. 3 pour obtenir les niveaux de sortie maximum pour les canaux gauche et droit. Lorsque les niveaux de sortie des canaux gauche et droit ne sont pas simultanément à leur maximum, les régler à nouveau de la façon suivante.</p> <p>3. Faire tourner la vis indiquée dans la Fig. 3 pour trouver les angles A et C (point où les niveaux de sortie de crête pour les canaux gauche et droit sont obtenus respectivement). Situer alors l'angle B entre les angles A et C, autrement dit, en un point où les niveaux de sortie des canaux gauche et droit atteignent tous deux leur maximum. (Voir les Fig. 3 et 4).</p>		
<p>Réglage de phase canal gauche/canal droit</p> <p>4. Brancher les appareils comme indiqué dans la Fig. 5.</p> <p>5. Reproduire le signal de 8kHz de la bande étalon (QZZCFM). Régler la vis (B) indiquée dans la Fig. 3 de sorte que les aiguilles des deux voltmètres électroniques oscillent au maximum, et qu'on obtienne sur l'oscilloscope une forme d'onde semblable à celle indiquée dans la Fig. 6.</p>		
<p>ⓐ Vitesse de défilement</p> <p>Condition:</p> <ul style="list-style-type: none"> • Mode de lecture <p>Equipement:</p> <ul style="list-style-type: none"> • Fréquencemètre numérique • Bande étalon... QZZCWAT 		
<p>Précision de la vitesse de défilement</p> <p>1. Brancher les appareils comme indiqué dans la Fig. 7.</p> <p>2. Lire la bande étalon (QZZCWAT, 3000Hz) et appliquer le signal de lecture au fréquencemètre numérique.</p>		

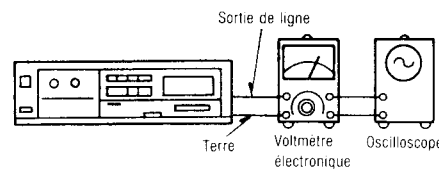

Fig. 2

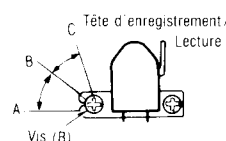

Fig. 3

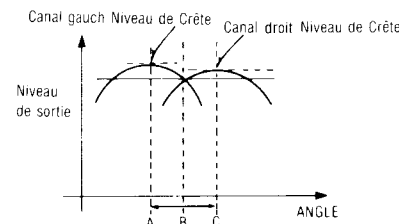

Fig. 4

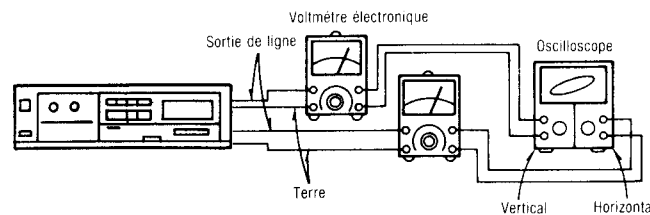

Fig. 5

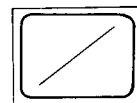

Fig. 6

3. Mesurer sa fréquence.
4. Sur la base de 3000Hz, déterminer la valeur à l'aide de la formule.

$$\text{Précision de vitesse} = \frac{f-3000}{3000} \times 100(\%)$$

avec f = valeur mesurée.

5. Effectuer la mesure sur la partie médiane de la bande.

Valeur standard: 0,33% (3000±10 Hz)

6. Si la valeur mesurée ne correspond pas à la valeur standard, régler au moyen de la vis VR de réglage de la vitesse de défilement indiquée dans la Fig. 1.

Remarque: Utiliser un tournevis qui ne soit pas métallique pour le réglage de la précision de la vitesse de défilement sur cette unité.

Fluctuations de vitesse de défilement

Faire les mesures de la même façon que ci-dessus (au début, au milieu et en fin de bande) et déterminer la différence entre les valeurs maximale et minimale, puis calculer comme suit.

$$\text{Fluctuations de vitesse} = \frac{f_1 - f_2}{3000} \times 100(\%)$$

f_1 = valeur maximale

f_2 = valeur minimale

Valeur standard: 1%

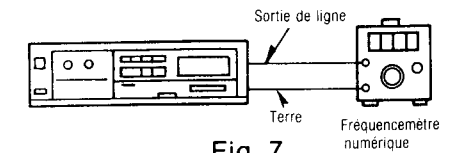

Fig. 7

<p>ⓐ Réponse en fréquence à la lecture</p>	<p>Condition:</p> <ul style="list-style-type: none"> • Mode de lecture 	<p>Equipement:</p> <ul style="list-style-type: none"> • Voltmètre électronique • Oscilloscope • Bande étalon ... QZZCFM
---	---	--

1. Brancher les appareils comme indiqué dans la Fig. 2.
2. Lire la portion de réponse en fréquence de la bande étalon (QZZCFM).
3. Mesurer les niveaux de sortie à 315 Hz, 12,5 kHz, 8 kHz, 4 kHz, 1 kHz, 250 Hz, 125 Hz, et 63 Hz et comparer chaque niveau de sortie avec celui de la fréquence standard de 315 Hz sur la borne LINE OUT.
4. Effectuer les mesures sur les deux canaux.
5. Vérifier que les valeurs mesurées se situent dans la bande spécifiée de la courbe de réponse en fréquence. (Voir Fig. 8).

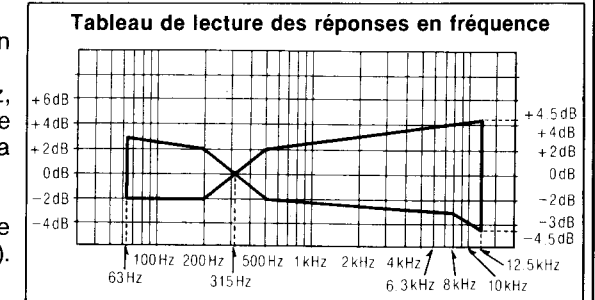

Fig. 8

<p>ⓐ Gain à la lecture</p>	<p>Condition:</p> <ul style="list-style-type: none"> • Mode de lecture 	<p>Equipement:</p> <ul style="list-style-type: none"> • Voltmètre électronique • Oscilloscope • Bande étalon... QZZCFM
-----------------------------------	---	---

1. Brancher les appareils comme indiqué dans la Fig. 2.
2. Faire jouer la portion du niveau d'enregistrement normal sur la bande d'essai (QZZCFM, 315 Hz) et, en utilisant un voltmètre électronique, mesurer le niveau de sortie aux sorties en ligne.
3. Effectuer les mesures sur les deux canaux.

Valeur standard: 0,4V±0,5dB (0,02V)

Réglage

1. Si la valeur mesurée ne correspond pas à la valeur standard régler VR5 (canal gauche) ou VR6 (canal droit).
2. Après réglage, vérifier à nouveau la "réponse en fréquence à la lecture".

<p>ⓐ Courant d'effacement</p>	<p>Condition:</p> <ul style="list-style-type: none"> • Mode d'enregistrement 	<p>Equipement:</p> <ul style="list-style-type: none"> • Voltmètre électronique • Oscilloscope • Bande étalon vierge ... QZZCRZ pour bande métallique
--------------------------------------	---	---

1. Brancher les appareils comme indiqué dans la Fig. 9.
2. Insérer la bande d'essai vierge de référence métallisée (QZZCRZ).
3. Appuyer sur les boutons d'enregistrement et de pause.
4. Lire le voltage sur le voltmètre électronique et calculer le courant d'effacement au moyen de la formule suivante:

$$\text{Courant d'effacement (A)} = \frac{\text{Voltage à la résistance R301}}{1 (\Omega)}$$

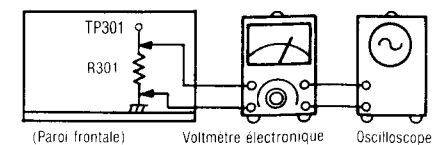

Fig. 9

Valeur standard: 155±15mA (bande métallique) (155±15mV)

5. Si la valeur mesurée ne correspond pas à la valeur standard, régler selon les instructions ci-après.

Réglage:

1. Court-circuiter les points (A) et (B) sur le tableau du circuit principal.
2. Mesurer le courant d'effacement.
3. Si le courant d'effacement est inférieur à 140 mA, court-circuiter le point (B).
4. Si le courant d'effacement est supérieur à 170 mA, court-circuiter le point (A).

Réponse de fréquence globale

Condition:
 • Mode enregistrement/lecture
 • Contrôles de niveau d'entrée...MAX

Equipement:
 • Voltmètre électronique
 • Atténuateur
 • Oscillateur
 • Oscilloscope
 • Résistance (600Ω)
 • Bande étalon vierge
 ...QZZCRA pour bande normale
 ...QZZCRX pour bande CrO₂
 ...QZZCRZ pour bande métallique

Remarque:

Avant de mesurer et régler la réponse de fréquence globale vérifier que la réponse en fréquence à la lecture soit correcte (pout la méthode de mesure, se reporter au paragraphe intitulé "Réponse en fréquence à la lecture").

(Le compensateur d'enregistrement est fixe.)

1. Brancher les appareils comme indiqué dans la Fig. 11.
 2. Insérer la bande d'essai vierge de référence normale (QZZCRA).
 3. Appliquer le signal de 1kHz de l'oscillateur AF à la borne LINE IN, par l'intermédiaire de l'atténuateur.
 4. Régler l'atténuateur de sorte que le niveau d'entrée soit de 20dB en-dessous du niveau d'enregistrement standard (niveau d'enregistrement standard = 0VU).
 5. Régler l'oscillateur AF pour produire des signaux de 50Hz 100Hz, 200Hz, 500Hz, 1kHz, 4kHz, 8kHz et 12,5kHz et enregistrer ces signaux sur la bande étalon.
 6. Reproduire les signaux enregistrés dans la phase 6, et vérifier si la courbe de réponse de fréquence se trouve dans les limites indiquées par la courbe de réponse de fréquence globale pour bandes normales (Fig. 10). (Si la courbe est comprise dans les spécifications, passer aux phases 7, 8 et 9).
- Si la courbe ne correspond pas aux spécifications du tableau, régler comme suit.

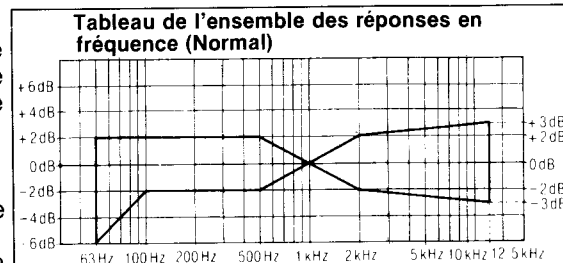

Fig. 10

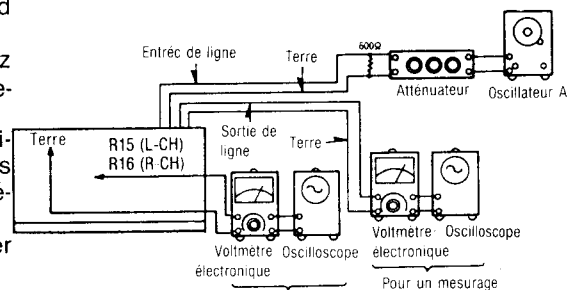

Fig. 11

Réglage (A):

Lorsque la courbe dépasse les spécifications du tableau de réponse de fréquence globale (Fig. 10), comme indiqué dans la Fig. 12.

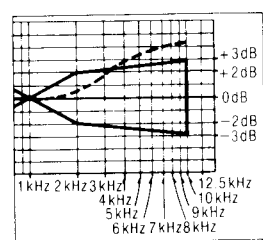

Fig. 12

- 1) Augmenter le courant de polarisation en tournant VR301 (canal gauche) et VR302 (canal droit).
- 2) Répéter les phases 5 et 6 pour confirmation. (Passer aux phases 7, 8 et 9 si la courbe est maintenant comprise dans les spécifications du tableau de la Fig. 10).
- 3) Si la courbe dépasse encore les spécifications (Fig. 10), augmenter encore le courant de polarisation et répéter les phases 5 et 6.

Réglage (B):

Lorsque la courbe tombe au-dessous des spécifications du tableau de fréquence globale (Fig. 10) comme indiqué dans la Fig. 13.

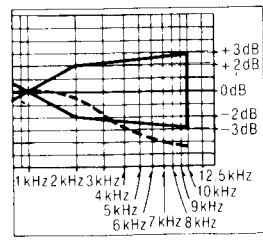

Fig. 13

- 1) Réduire le courant de polarisation en tournant VR301 (canal gauche) et VR302 (canal droit).
- 2) Répéter les phases 5 et 6 pour confirmation. (Passer aux phases 7, 8 et 9 si la courbe est maintenant comprise dans les spécifications du tableau de la Fig. 10).
- 5) Si la courbe tombe encore au-dessous des spécifications du tableau (Fig. 10), réduire encore le courant de polarisation et répéter les phases 5 et 6.

7. Insérer la bande d'essai vierge de référence CrO₂ (QZZCRX).
8. Enlever la bande étalon vierge normale et placer la bande étalon QZZCRX (bande CrO₂). Enregistrer les signaux de 50Hz, 100Hz, 200Hz, 500Hz, 1kHz, 4kHz, 8kHz, 10kHz et 15kHz. Reproduire ensuite ces signaux et vérifier si la courbe est comprise dans les limites indiquées par le tableau de réponse de fréquence globale pour les bandes CrO₂ (Fig. 14).
9. Changer la bande étalon pour la bande étalon vierge QZZCRZ (bande métallique), et enregistrer les signaux de 50Hz, 100Hz, 200Hz, 500Hz, 1kHz, 4kHz, 8kHz, 10kHz et 15kHz. Ensuite, lire les signaux et vérifier si la courbe se trouve entre les limites indiquées dans le tableau de réponse en fréquence globale pour les ruban CrO₂ (Fig. 14).
10. Confirmer que les voltage de polarisation sont approximativement les suivants lorsque le sélecteur de bande est mis sur ses différentes positions.

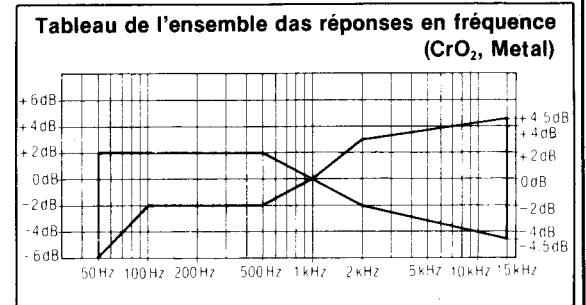

Fig. 14

• Lire la tension aux bornes de la résistance R15 (canal gauche) [R16 (canal droit)], et calculer le courant de polarisation à partir de la formule suivante.

$$\text{Courant de polarisation (A)} = \frac{\text{Tension lue sur voltm. elec. (V)}}{10 (\Omega)}$$

VALEUR STANDARD: Autour de 170 μA (Position: Normal)
 Autour de 200 μA (position: CrO₂)
 Autour de 370 μA (position: Metal)

Gain global

Condition:
 • Mode d'enregistrement/lecture
 • Contrôles de niveau d'entrée ...MAX
 • Niveau d'entrée standard:
 MIC -72⁺⁵/₋₃ dB
 (0,25 mV)
 LINE IN -24±4 dB
 (63 mV)

Equipement:
 • Voltmètre électronique
 • Oscillateur AF
 • Atténuateur
 • Oscilloscope
 • Résistance (600Ω)
 • Bande étalon vierge...QZZCRA pour bande normale

1. Brancher les appareils comme indiqué dans la Fig. 15.
2. Introduire la bande étalon vierge (QZZCRA).
3. Placer l'UNITE en mode d'enregistrement.
4. Appliquer le signal de 1kHz de l'oscillateur AF à la borne LINE IN, par l'intermédiaire de l'atténuateur (-24dB).
5. Régler ATT jusqu'à ce que le niveau du moniteur aux sorties de ligne soit de 0,4V.
6. Faire jouer la bande enregistrée et s'assurer que le niveau de sortie aux sorties en ligne soit de 0,4V.
7. Si la valeur mesurée n'est pas de 0,42 V, régler au moyen de VR103 (canal gauche) ou VR104 (canal droit).
8. Recommencer à partir de la phase (2).

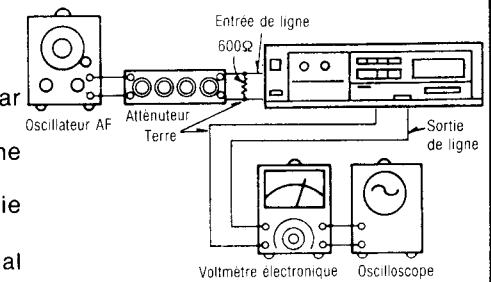

Fig. 15

Vumètre de niveau

Condition:
 • Mode d'enregistrement
 • Contrôles de niveau d'entrée ...MAX

Equipement:
 • Voltmètre électronique
 • Atténuateur
 • Oscillateur AF
 • Oscilloscope
 • Résistance (600Ω)

1. La connexion de l'équipement d'essai est montré sur la Fig. 15.
2. Placer l'appareil sur le mode d'enregistrement.
3. Transmettre un signal de 1kHz (-24dB) à partir de l'oscillateur d'audiofréquence par l'atténuateur LINE IN.

Réglage à "-40 dB"

4. Régler l'atténuateur de sorte que le niveau réglé à la phase 3 soit réduit de 40 dB.
5. A ce moment, vérifier que le segment -40 dB s'obscurisse (luminosité intermédiaire entre pleine luminosité et extinction: voir Fig. 17).
6. Si la luminosité du segment n'est pas comme celle mentionnée à la phase 6 ci-dessus, régler le VR102.

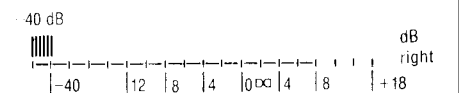

Fig. 16

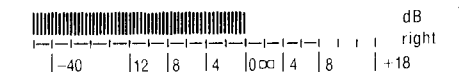

Fig. 17

Sírvase utilizarse junto con manual de servicio para el model No. RS-B55.

Réglage à "0 dB"

- Rétablir les conditions de la phase 3 (niveau de sortie sur la borne LINE OUT de valeur 0,43 V±0,02V).
- A ce moment, vérifier que le segment 0 dB s'obscurcisse (luminosité intermédiaire entre pleine luminosité et extinction: voir Fig. 18).
- Si la luminosité du segment n'est pas come indiqué ci-dessus, régler le VR201.
- Répéter les réglages et vérifications des phases 3, 4, 5, 6, 7, 8 et 9 deux ou trois fois.

1 Circuit de réduction de bruit Dolby

Condition:

- Mode d'enregistrement
- Interrupteur de réduction de bruit Dolby...IN/OUT
- Interrupteur de sélection du système de réduction de bruit Dolby...B/C
- Contrôles de niveau d'entrée...MAX
- Contrôle de l'équilibre ...Centre

Equipement:

- Voltmètre électronique
- Oscillateur AF
- Atténuateur
- Oscilloscope
- Résistance (600Ω)

Côté enregistrement

- Vérification des caractéristiques du codeur de type Dolby-B
 - Brancher les appareils comme indiqué dans la Fig. 18.
 - Placer l'unité sur le mode d'enregistrement. (L'interrupteur de sélection du système de réduction de bruit est sur la position OUT).
 - Appliquer un signal de 1kHz à la borne LINE IN.
 - Régler l'atténuateur de sorte que le niveau de sortie à la points 7 des circuits intégrés IC401 (canal gauche) et IC402 (canal droit) soit de 12,3mV (375mV).
 - Le niveau de sortie à la pointe 21 devrait être de 0dB.
 - Placer l'interrupteur de sélection du système de réduction de bruit sur B et s'assurer que le niveau du signal de sortie à la pointe 21 des circuits intégrés IC401 (canal gauche) et IC402 (canal droit) est de +6 dB±1,5 dB (753 mV).
 - Placer l'interrupteur de sélection du système de réduction de bruit sur la position OUT et régler la fréquence sur 5kHz. Le niveau du signal de sortie à la pointe 21 devrait être de 0dB (375mV).
 - Placer l'interrupteur de sélection du système de réduction de bruit sur la position B et s'assurer que le niveau du signal de sortie à la pointe 21 des circuits intégrés IC401 (canal gauche) et IC402 (canal droit) soit de +8 dB±1,5 dB (948 mV).
- Vérification des caractéristiques du codeur de type Dolby-C
 - Répéter les phases 1 à 5 ci-dessus.
 - Placer l'interrupteur de sélection du système de réduction de bruit Dolby sur la position C et s'assurer que le niveau de signal de sortie à la pointe 21 des circuits intégrés IC401 (canal gauche) et IC402 (canal droit) soit de 11,5 dB±2 dB (1,4 V).
 - Placer l'interrupteur de sélection du système de réduction de bruit sur la position OUT et régler la fréquence sur 5kHz. Le niveau du signal de sortie à la pointe 21 devrait être de 0dB (375mV).
 - Placer l'interrupteur de sélection du système de réduction de bruit sur la position C et s'assurer que le niveau du signal de sortie à la pointe 21 des circuits intégrés IC401 (canal gauche) et IC402 (canal droit) soit de +8,5 dB ±2 dB (1 V).

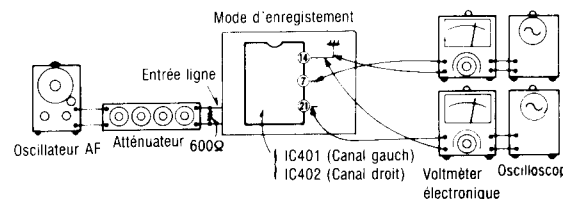

Fig. 18

2 Réglage du temps de recouvrement à l'attaque (circuit dbx)

Condition:

- Mode d'enregistrement
- Contrôles de niveau d'entrée...MAX
- Contrôle de l'équilibre ...Centre

Equipement:

- Voltmètre électronique
- Atténuateur
- Oscillateur AF
- Voltmètre CC
- Sélecteur de réduction de bruit...position de bande dbx ("dbx tape")

- Faire les branchements comme indiqué dans la Fig. 19 et appliquer un signal de 1kHz -27dB à la borne LINE IN. Placer le sélecteur de réduction de bruit sur la position de bande dbx ("dbx tape").
- Placer l'unité sur le mode d'enregistrement. Régler l'atténuateur de sorte que le niveau de signal à C541 (canal gauche) et à C542 (canal droit) soit de 300mV.
- Lire la tension indiquée sur le voltmètre CC.

Valeur de référence: 15±0,5 mV

- Si la valeur lue ne correspond pas à la valeur de référence, régler VR101.

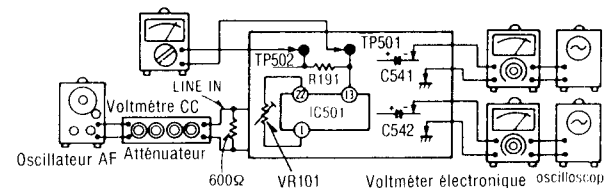

Fig. 19

■ ESPECIFICACIONES TECNICAS

Sistema de platina	Platina de cassette estéreo	con dbx	92 dB (promedio A)
Sistema de pistas	4 pistas, 2 canales	con reducción de ruidos Dolby C	75 dB (CCIR)
Cabezas de GRAB/REPROD	Cabeza de AX	con reducción de ruidos Dolby B	67 dB (CCIR)
Cabezas de borrado	Cabeza de ferrita de 2 entrehierros	sin reducción de ruidos	57 dB (promedio A)
Motores	1 Motor	Variación de velocidad	0,07% (WRMS) ±0,13% (DIN)
Frecuencia de polarización	80 kHz	Máximá mejorá de nivel de entradá (con dbx)	10 dB (1 kHz)
Sistema de borrado	Polarización de CA	Tiempo de avance rápido y rebobinado	Approx. 90 segundos con cintas C-60
Velocidad de cinta	4,8 cm/seg.	Sensibilidad de entrada e impedancia	
Respuesta de frecuencia		MIC	0,25 mV/400 Ω~10 kΩ
Metal	20 Hz~19.000 Hz	LINE	60 mV/47 kΩ
	30 Hz~18.000 Hz (DIN)	Voltaje de salida e impedancia	
	40 Hz~17.000 Hz±3 dB	LINE	400 mV/1,5 kΩ
CrO₂	20 Hz~18.000 Hz	HEADPHONES	80 mV/8 Ω
	30 Hz~17.000 Hz (DIN)	Consumo de corriente	18 W
	40 Hz~16.000 Hz±3 dB	Alimentación de energía	220 V para Europe realizar Royaume-Uni.
Normal	20 Hz~17.000 Hz	Dimensiones (An.×Al×Prof.)	430×99,5×229 mm
	30 Hz~16.000 Hz(DIN)	Peso	3,5 kg
	40 Hz~15.000 Hz±3 dB		
Gámá dinámica (con dbx)	110 dB (1 kHz)		
Señal a ruido:	(nivel de señal = nivel de grabación máx. tipo de cinta CrO ₂)		

■ METODOS DE AJUSTE Y MEDIDA

NOTAS: Colocar los interruptores y controles en las posiciones siguientes a no ser que se especifique lo contrario:

- Asegurarse de que las cabezas estén limpias.
- Asegurarse de que los cabrestantes y los rodillos presores estén limpios.
- Temperatura ambiente aconsejable: 20±5°C (68±9°F)
- Interruptor NR: OUT
- Selector de cinta: Normal
- Selector de entrada: Line in
- Controles del nivel de entrada: Máximo
- Control del balance: Centro

A Ajuste de azimut de las cabezas

Condición:

- Modo de reproducción

Equipo:

- EVM (Voltmetro electrónico)
- Osciloscopio
- Cinta de prueba (azimut) ...QZZCFM

Ajuste del equilibrio de salida L-CH/R-CH (canal izquierdo/canal derecho)

- Efectuar las conexiones como muestra la Fig. 2.

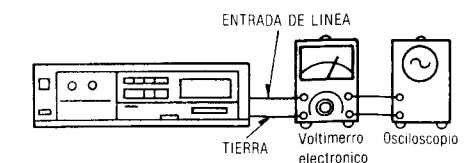

Fig. 2

- Reproducir la señal de 8kHz desde la cinta de prueba (QZZCFM). Ajustar el tornillo (B) en Fig. 3 para obtener niveles L-CH y R-CH de salida máxima. Cuando los niveles de salida de L-CH y R-CH no están al máximo, al mismo tiempo, reajustar de la siguiente forma:
- Girar el tornillo mostrado en Fig. 3 para buscar los ángulos A y C (puntos donde los niveles de salida de cresta se obtienen para los canales derecho y izquierdo). Luego, localizar el ángulo B entre los ángulos A y C, por ej., el punto donde los niveles de salida de R-CH y L-CH estén equilibrados. (Consultar Fig. 3 y 4.)

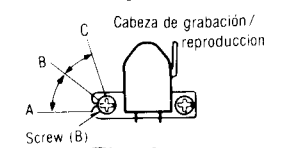

Fig. 3

Ajuste de fase de L-CH/R-CH

- Efectuar las conexiones como muestra la Fig. 5.
- Reproducir la señal de 8kHz desde la cinta de prueba (QZZCFM). Ajustar el tornillo. (B) de la Fig. 3 de forma que las agujas indicadoras de los dos EVM giren hacia el máximo y se obtenga una forma de onda como la indicada en la Fig. 6 sobre el osciloscopio.

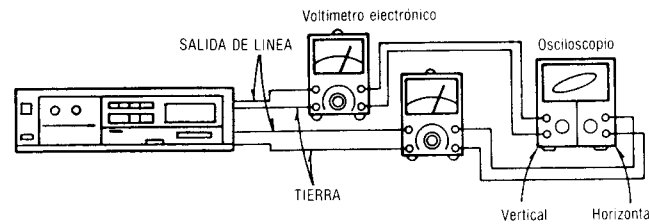

Fig. 5

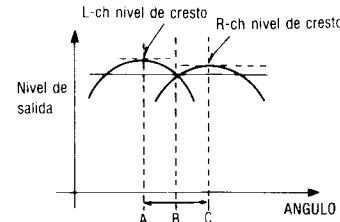

Fig. 4

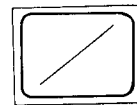

Fig. 6

Velocidad de la cinta

Condición:
• Modo de reproducción

Equipo:
• Contador digital electrónico
• Cinta de prueba...QZZCWAT

Exactitud de la velocidad de cinta

- La conexión del equipo de prueba se muestra en Fig. 7.
- Reproducir la cinta de prueba (QZZCWAT 3.000Hz), y suministrar una señal de reproducción al contador digital electrónico.
- Medir esta frecuencia.
- Sobre la base de 3.000Hz, determinar el valor de la exactitud mediante la siguiente fórmula:

$$\text{Exactitud de la velocidad de cinta} = \frac{f - 3.000}{3.000} \times 100(\%)$$

donde f = valor medido

- Tomar medida en la sección media de la cinta.

Valor normal: 0,33% (3000±10Hz)

- Si el valor medido no está dentro del valor estándar, ajustarlo usando el ajuste de velocidad de cinta VR mostrado.

Nota: No utilizar destornilladores metálicos cuando ajuste la precisión de la velocidad de la cinta en este aparato.

Fluctuación de la velocidad de cinta

Efectuar las mediciones de la misma manera que antes (al comienzo, mitad y final de la cinta) y determinar la diferencia entre los valores máximo y mínimo. Calcular de la forma siguiente:

$$\text{Fluctuación de la velocidad de cinta} = \frac{f_1 - f_2}{3.000} \times 100(\%)$$

f₁ = valor máximo,
f₂ = valor mínimo

Valor normal: menos de 1%

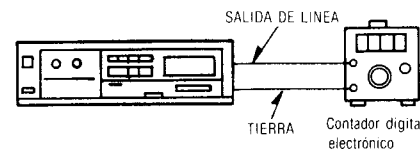

Fig. 7

Respuesta de frecuencia de reproducción

Condición:
• Modo de reproducción

Equipo:
• EVM (Voltímetro electrónico)
• Osciloscopio
• Cinta de prueba...QZZCFM

- La conexión del equipo de prueba se muestra en la Fig. 2.
- Reproducir la cinta de prueba de respuesta de frecuencia (QZZCFM).
- Medir el nivel de salida en 315Hz, 12,5kHz, 8kHz, 4kHz, 1kHz, 250Hz, 125Hz y 63Hz y comparar cada nivel de salida con 315Hz de frecuencia normal, en LINE OUT.
- Efectuar las medidas para ambos canales.
- Asegurarse de que el valor medido está comprendido dentro de la gama especificada en el gráfico de la respuesta de frecuencia (mostrado en la Fig. 8).

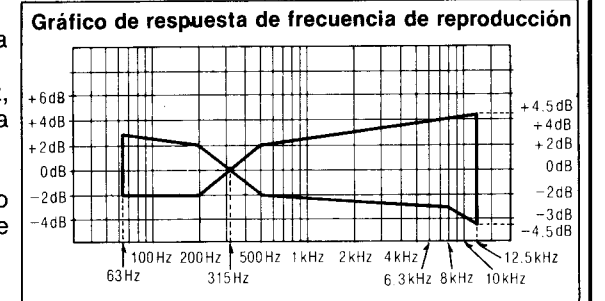

Fig. 8

Ganancia de reproducción

Condición:
• Modo de reproducción

Equipo:
• EVM (Voltímetro electrónico)
• Osciloscopio
• Cinta de prueba...QZZCFM

- La conexión del equipo de prueba se muestra en la Fig. 2.
- Reproduzca la porción de nivel de grabación estándar en la cinta de prueba (QZZCFM 315Hz) y, usando EVM (voltímetro electrónico), mida el nivel de salida en "LINE OUTs" (salidas de línea).
- Efectuar las medidas para ambos canales.

Valor normal: 0,4V±0,5dB (0,02V)

Ajuste

- Si el valor medido no está comprendido dentro del valor normal, ajustar VR5 (L-CH), VR6 (R-CH).
- Después del ajuste, comprobar de nuevo la "respuesta de frecuencia de reproducción".

Corriente de borrado

Condición:
• Modo de grabación

Equipo:
• EVM (Voltímetro electrónico)
• Osciloscopio
• Cinta de prueba...QZZCRZ para Metal

- La conexión del equipo de prueba se muestra en la Fig. 9.
- Insertar la cinta de prueba virgen de referencia metálica (QZZCRZ).
- Apretar los botones de pausa y grabación.
- Tomar la lectura del voltaje en EVM y calcular la corriente de borrado mediante la fórmula siguiente:

$$\text{Corriente de borrado (A)} = \frac{\text{Voltaje entre terminales de R301}}{1 (\Omega)}$$

Valor normal: 155±15mA (Modo de cinta...Metal) (155±15mV)

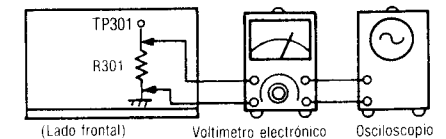

Fig. 9

- Si el valor medido no está comprendido dentro del valor normal, ajustar de la forma siguiente:

Ajuste:

- Cortocircuitar los puntos (A) y (B) en el tablero principal del circuito.
- Efectuar la medida de la corriente de borrado.
- Si la corriente de borrado es menor que 140 mA, cortocircuitar el punto (B).
- Si la corriente de borrado es superior a 170 mA, dejar en circuito abierto los puntos (A).

Respuesta de frecuencia total

Condición:
• Modo de reproducción/
grabación
• Control de nivel de entrada
...MAX

Equipo:
• EVM (Voltímetro electrónico)
• ATT
• Oscilador de AF
• Osciloscopio
• Resistor (600Ω)
• Cinta de prueba (cinta en blanco de referencia)
...QZZCRA para Normal
...QZZCRX para CrO₂
...QZZCRZ para Metal

Nota:

Antes de medir y ajustar la respuesta de frecuencia total, asegurarse de la respuesta de frecuencia de reproducción. (Para el método de medida, sírvase consultar la respuesta de frecuencia de reproducción).

(Se fija el compensador de grabación.)

1. Efectuar las conexiones tal como se muestra en la Fig. 11.
2. Insertar la cinta de prueba virgen de referencia normal (QZZCRA).
3. Aplicar una señal de 1kHz desde el oscilador de AF a través de ATT a LINE IN.
4. Ajustar el ATT de forma que el nivel de entrada sea de -20dB por debajo del nivel estándar de grabación (nivel estándar de grabación = 0VU).
5. Ajustar el oscilador de AF para generar señales de 50Hz, 100Hz, 200Hz, 500Hz, 1kHz, 4kHz, 8kHz y 12,5kHz y grabar, estas señales en la cinta de prueba.
6. Reproducir las señales grabadas en el paso 6, y comprobar si la curva de respuesta de frecuencia está dentro de los límites mostrados en el gráfico de respuesta de frecuencia total para las cintas normales (Fig. 10).
(Si la curva está dentro de las especificaciones del gráfico, seguir con los pasos 7, 8 y 9).
Si la curva no está dentro de las especificaciones del gráfico, ajustar de la forma siguiente:

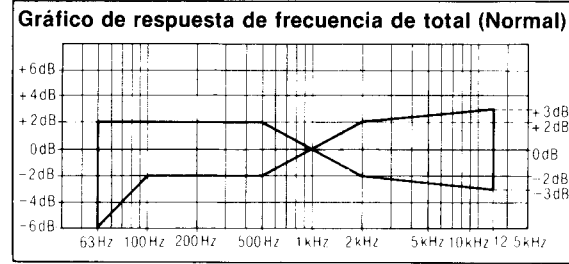

Fig. 10

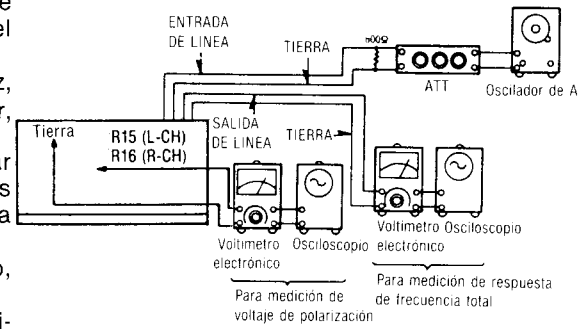

Fig. 11

Ajuste A:

Cuando la curva excede las especificaciones del gráfico de respuesta de frecuencia total (Fig. 10) tal como se muestra en la Fig. 12.

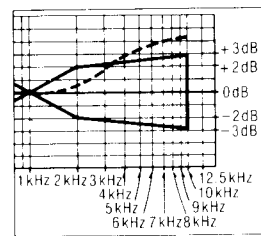

Fig. 12

- 1) Aumentar la corriente de polarización girando VR301 (L-CH) y VR302 (R-CH).
- 2) Repetir los pasos 5 y 6 para confirmación. (Seguir con los pasos 7, 8 y 9 si la curva está ahora dentro de las especificaciones del gráfico de la Fig. 10).
- 3) Si la curva todavía excede las especificaciones (Fig. 10), aumentar aún más la corriente de polarización y repetir los pasos 5 y 6.

Ajuste B:

Cuando la curva está por debajo de las especificaciones del gráfico de respuesta de frecuencia total (Fig. 10) tal como se muestra en la Fig. 13.

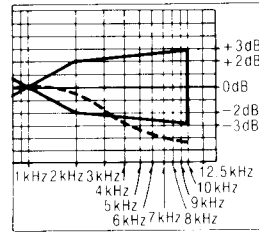

Fig. 13

- 1) Reducir la corriente de polarización girando VR301 (L-CH) y VR302 (R-CH).
- 2) Repetir los pasos 5 y 6 para confirmación. (Seguir con los pasos 7, 8 y 9 si la curva está ahora dentro de las especificaciones del gráfico de la Fig. 10).
- 3) Si la curva todavía cae por debajo de las especificaciones del gráfico (Fig. 10), reducir aún más la corriente de polarización y repetir los pasos 5 y 6.

7. Cambiar la cinta de prueba a QZZCRX y grabar señales de 50Hz, 100Hz, 200Hz, 500Hz, 1kHz, 4kHz, 8kHz, 10kHz y 15kHz. Luego, reproducir las señales y comprobar si la curva está dentro de los límites mostrados en el gráfico de respuesta de frecuencia total para las cintas CrO₂ (Fig. 14).
8. Cambiar la cinta de prueba a QZZCRZ, y grabar señales de 50Hz, 100Hz, 200Hz, 500Hz, 1kHz, 4kHz, 8kHz, 10kHz y 15kHz. Luego, reproducir las señales y comprobar si la curva está dentro de los límites mostrados en el gráfico de respuesta de frecuencia total para las cintas de Metal (Fig. 14).
9. Asegurarse de que las tensión de polarización sean aproximadamente las que se indican a continuación cuando el aparato esté colocado en un modo de cinta distinto.
 - Medir la tensión en la cabeza utilizando el EVM.
 - Lea el voltaje en los terminales del registro R15 (L-CH) [R16 (R-CH)] y calcule la corriente de polarización de la fórmula siguiente.

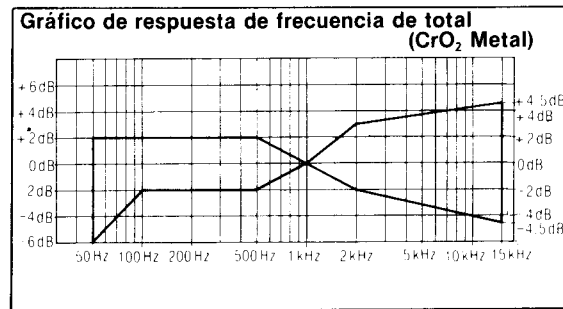

Fig. 14

$$\text{Corriente de polarización (A)} = \frac{\text{Valor leído en el EVM (V)}}{10 (\Omega)}$$

Unos 170 μA (posición: Normal)
VALOR NORMAL: Unos 200 μA (posición: CrO₂)
 Unos 370 μA (posición: Metal)

Ⓒ Ganancia total

Condición:

- Modo de reproducción/ grabación
- Controles del nivel de entrada ...MAX.
- Nivel de entrada normal:
 - MIC -72 +5 -3 dB (0,25 mV)
 - LINE IN -24 ±4 dB (63 mV)

Equipo:

- EVM (Voltímetro electrónico)
- Oscilador de AF
- ATT
- Osciloscopio
- Resistor (600 Ω)
- Cinta de prueba (cinta en blanco de referencia) ...QZZCRA para Normal

1. La conexión del equipo de prueba se muestra en la Fig. 15.
2. Cargar la cinta normal en blanco de referencia (QZZCRA).
3. Poner el aparato en el modo grabación.
4. Suministrar una señal 1kHz (-24dB) desde el oscilador de AF a través de ATT a LINE IN (ENTRADA DE LINEA).
5. Ajustar ATT hasta que el nivel del monitor en "LINE OUTS" sea 0,4V.
6. Reproduzca la cinta grabada y asegúrese de que el nivel de salida en "LINE OUTs" sea 0,4V.
7. Si el valor medido no es de 0,42V, ajustarlo con VR103 (L-CH), VR104 (R-CH).
8. Repetir desde el punto (2).

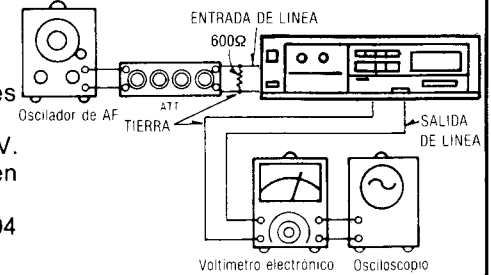

Fig. 15

Ⓓ Medidor de nivel

Condición:

- Modo de grabación
- Controles del nivel de entrada ...MAX

Equipo:

- EVM (Voltímetro electrónico)
- ATT
- Oscilador de AF
- Osciloscopio
- Resistor (600 Ω)

1. Comprobar la conexión del equipo que se muestra en la Fig. 15.
2. Colocar la unidad en el modo de grabación.
3. Suministrar una señal de 1kHz (-24dB) desde el oscilador de AF a través del ATT a la ENTRADA DE LINEA (LINE IN).

Ajuste a "-40 dB"

4. Ajustar ATT de forma que el nivel ajustado en el paso 3 se reduzca en 40 dB.
5. En este momento, comprobar si el indicador de -40 dB está iluminado a medias (intensidad luminosa intermedia entre intensidad máxima y apagado: ver la Fig. 16).
6. Si el indicador no está iluminado a medias tal como se ha descrito en el paso 6, ajustar VR102.

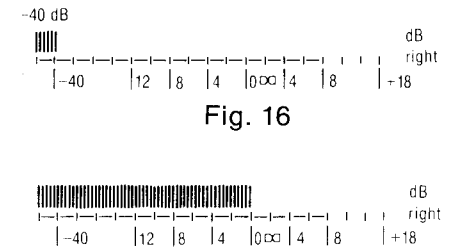

Fig. 16

Ajuste a "0 dB"

7. Volver a las condiciones del paso 3 (hacer que el nivel de salida en LINE OUT sea de 0,43 V ± 0,02 V).
8. En este momento, comprobar si el indicador de 0 dB está iluminado a medias (intensidad luminosa intermedia entre intensidad máxima y apagado: ver la Fig. 17).
9. Si no es así, ajustar VR201.
10. Repetir los ajustes y comprobaciones de los pasos 3, 4, 5, 6, 7, 8 y 9 dos o tres veces.

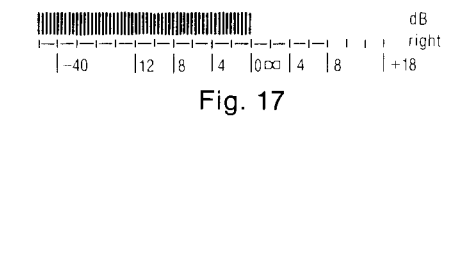

Fig. 17

Ⓔ Circuito Dolby de ruido (NR)

Condición:

- Modo de grabación
- Interruptor Dolby NR ...IN/OUT
- Interruptor selector del Dolby NR...B/C
- Controles del nivel de entrada...MAX

Equipo:

- EVM (Voltímetro electrónico)
- ATT
- Resistor (600 Ω)
- Oscilador de AF
- Osciloscopio

Lado de grabación

- Comprobación de las características del condificador tipo Dolby B.
 1. Efectuar las conexiones según se muestra en la Fig. 18.
 2. Colocar la unidad en el modo de grabación (el interruptor selector NR está en OUT).
 3. Aplicar una señal de 1kHz a LINE IN.
 4. Ajustar el ATT de forma que el nivel de salida en el terminal 7 del IC401 (L-CH) e IC402 (R-CH) sea de 12,3mV.
 5. El nivel de salida en el terminal 21 deberá ser de 0dB (375mV).
 6. Colocar el interruptor selector NR en B, y asegurarse de que el nivel de la señal de salida en el terminal 21 del IC401 (L-CH) e IC402 (R-CH) sea de +6 dB ± 1,5 dB (753 mV).

7. Colocar el interruptor NR en OUT y ajustar la frecuencia a 5kHz. El nivel de la señal de salida en el terminal 21 deberá ser de 0dB (375mV).
 8. Colocar el interruptor selector NR en B y asegurarse de que el nivel de la señal de salida en el terminal 21 del IC401 (L-CH) e IC402 (R-CH) sea de +8 dB±1,5 dB (948 mV).
- Comprobación de las características del codificador tipo Dolby C.
9. Repetir los pasos 1 a 5 anteriores.
 10. Colocar el interruptor selector NR en C y asegurarse de que el nivel de la señal de salida en el terminal 21 del IC401 (L-CH) e IC402 (R-CH) sea de +11,5 dB±2 dB (1,4 V).
 11. Colocar el interruptor selector NR en la posición OUT y ajustar la frecuencia a 5kHz. La señal de salida en el terminal 21 deberá ser de 0dB (375mV).
 12. Colocar el interruptor selector NR en C, y asegurarse de que el nivel de la señal de salida del terminal 21 del IC401 (L-CH) e IC402 (R-CH) sea de +8,5 dB±2 dB (1 V).

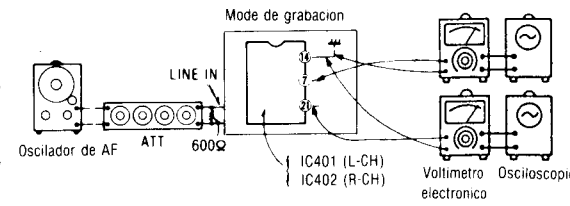

Fig. 18

● **Ajuste del tiempo de recuperación de ataque (circuit dbx)**

<p>Condición:</p> <ul style="list-style-type: none"> • Modo de grabación • Controles del nivel de entrada...MAX • Control del balance ...Centro 	<p>Equipo:</p> <ul style="list-style-type: none"> • EVM • ATT • Oscilador de AF • Voltímetro de CC • Selector de reducción de ruido...cinta dbx
--	--

1. Hacer las conexiones que se muestran en la Fig. 19, y suministrar una señal de 1kHz -27dB desde LINE IN. Colocar también el selector de reducción de ruido en la posición de cinta dbx.
2. Colocar la unidad en el modo de grabación, y ajustar ATT de forma que el nivel de la señal en C541 (L-CH) y C542 (R-CH) sea de 300mV.
3. Lee el voltaje en el voltímetro de CC.

Valor de referencia: 15±0,5 mV

4. Si el valor medido no está dentro del valor de referencia, ajustar VR101.

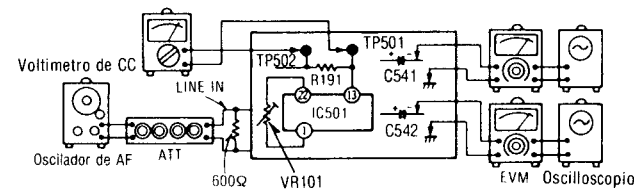

Fig. 19

SAFETY PRECAUTION (This "safety precaution" is applied only in U.S.A.)

1. Before servicing, unplug the power cord to prevent an electric shock.
2. When replacing parts, use only manufacturer's recommended components for safety.
3. Check the condition of the power cord. Replace if wear or damage is evident.
4. After servicing, be sure to restore the lead dress, insulation barriers, insulation papers, shields, etc.
5. Before returning the serviced equipment to the customer, be sure to make the following insulation resistance test to prevent the customer from being exposed to a shock hazard.

INSULATION RESISTANCE TEST

1. Unplug the power cord and short the two prongs of the plug with a jumper wire.
2. Turn on the power switch.
3. Measure the resistance value with ohmmeter between the jumpered AC plug and each exposed metal cabinet part, such as screwheads antenna, control shafts, handle brackets, etc. Equipment with antenna terminals should read between $3M\Omega$ and $5.2M\Omega$ to all exposed parts. (Fig. A) Equipment without antenna terminals should read approximately infinity to all exposed parts. (Fig. B)

Note: Some exposed parts may be isolated from the chassis by design. These will read infinity.

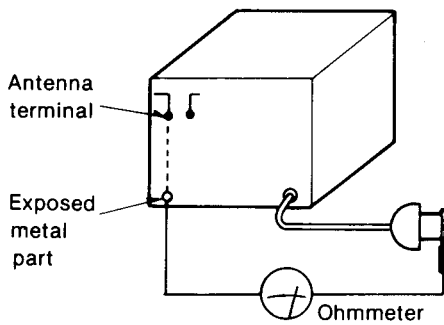

(Fig. A)

Resistance = $3M\Omega$ — $5.2M\Omega$

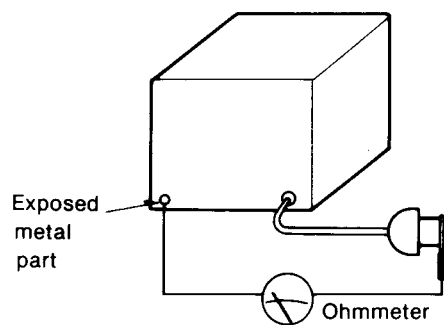

(Fig. B)

Resistance = Approx ∞

4. If the measurement is outside the specified limits, there is a possibility of a shock hazard. The equipment should be repaired and rechecked before it is returned to the customer.

OPERATIONS

STANDARD OPERATING PROCEDURES

Note:

To remove the cassette while the unit is recording or playing back (including the tune-select mode), be sure to first press the stop button and then press the eject button. If only the eject button is pressed, without first pressing the stop button, this may cause the tape to become loosely wound or otherwise tangle the tape.

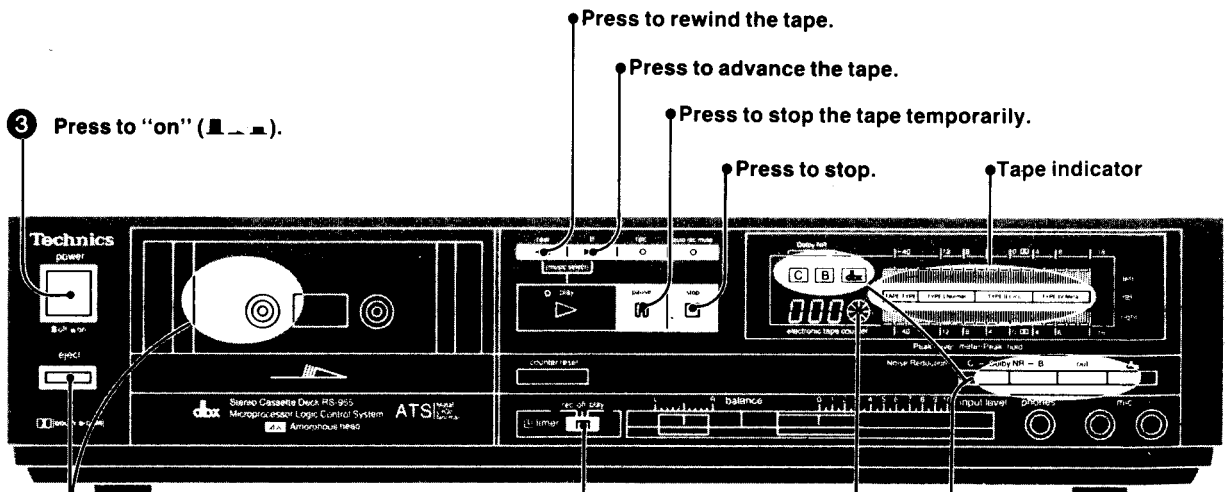

- 1 **Insert the cassette.**
Be sure the edge of the cassette where the tape can be seen faces down.
When the cassette is inserted and the cassette holder is closed, the tape indicator illuminates to indicate the type of tape.

- 2 **Set to the "off" position.**
The tape-running display will increase by 1 for each rotation.

- 4 **Select the noise-reduction system.**
The corresponding noise-reduction indicator illuminates depending on which button is pressed.

PLAYBACK

Tune selection

This feature is used to find the beginning of a tune, either before or after the present position of the tape.

- 1 Press. (Playback will begin.)
- 2 Press to listen to the previous tune. (The playback indicator will begin flashing rapidly, and the unit will begin searching for the beginning of the previous tune.)
- 2 Press to listen to the next tune. (The playback indicator will begin flashing rapidly, and the unit will begin searching for the beginning of the next tune.)

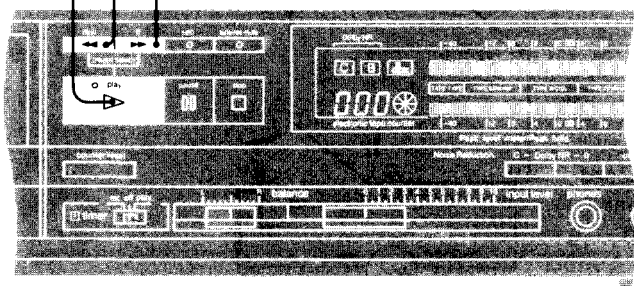

To find a tune which is a few tunes ahead (or before) on the tape, repeat step 2.

The tune-select system will not function correctly under the following conditions:

- If there is 4 seconds or less between tunes (unrecorded space)
- If there is excessive noise between tunes
- If there is a very low-sound level place, or an unrecorded space, during a tune
- If the tape has been recorded by using fade-in and/or fade-out* techniques

*Fade-in and Fade-out

Fade-in is a recording technique to gradually increase the sound (from 0 to the ordinary level) at the beginning of a recording, and fade-out is to gradually decrease the sound (from the ordinary level to 0) at the end of a recording.

• Music select system manufactured under license of Starr, S.A., Bruxelles, Belgium.

RECORDING

Have you finished reading "STANDARD OPERATING PROCEDURES" on page 3?

When only one microphone is connected at the left or right, the line input at the connected side is cut off. When recording with one microphone, the line inputs at both sides are cut off once the balance control is slid to the side (left or right) at which the microphone has been connected.

(Mono type, 1/4 inch phone plug, option)

(left) (right)



- 2 Begin the sound source to be recorded.

- 1 Press. (Record stand-by.)

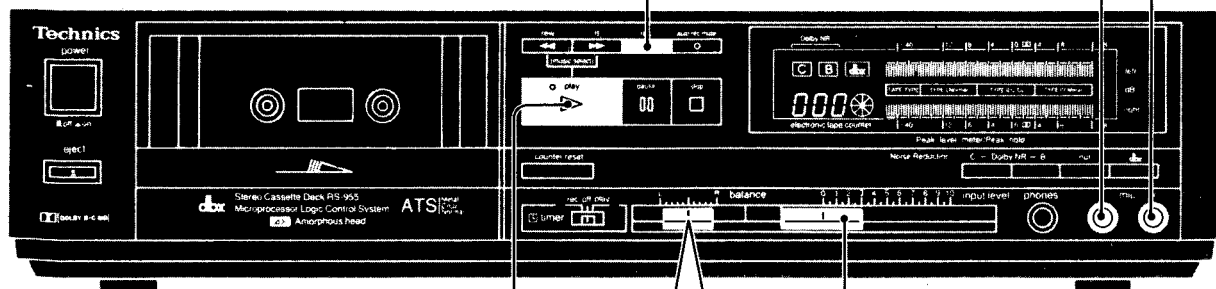

- 4 Press. (Recording starts.)

Usually set to the center ("click") position.

- 3 Adjust the recording level.

Adjustment of the recording level

The number that you can use as a guide will vary depending upon the type of tape used and the type of noise-reduction system employed for the recording.

Noise Reduction (NR)	Normal Tape CrO ₂ Tape	Metal Tape
Dolby NR B·C NR out	+6 dB	+8 dB
dbx	+8 dB	+12 dB

•The recording level can also be adjusted by the level bar illumination of the fluorescent level meter.

Record muting

This is a feature which makes it possible to make a non-recorded portion on the tape while a recording is in progress. This feature should be used at the following times:

•To avoid recording unwanted commercial announcements and to avoid recording the noise produced when the phono needle descends to a disc.

During recording...

To make the non-recorded portion of about 4 seconds between tunes:

•**Press once.**
(After about 4 seconds, the unit will automatically change to the recording stand-by mode.)

To make a non-recorded portion of more than 4 seconds:
Press for more than 4 seconds.
(The unit will automatically change to the recording stand-by mode when the button is released.)

Erasing recorded sounds

When a recording is made, any sounds previously recorded on that portion of the tape are erased, and only the new recording remains. To erase recorded sounds without making a new recording, proceed as follows.

- 1 Set to the minimum (0) position. (Input Level Control)
- 2 Press the "out" Button. (Noise Reduction Switch)
- 3 Begin recording in the usual way.

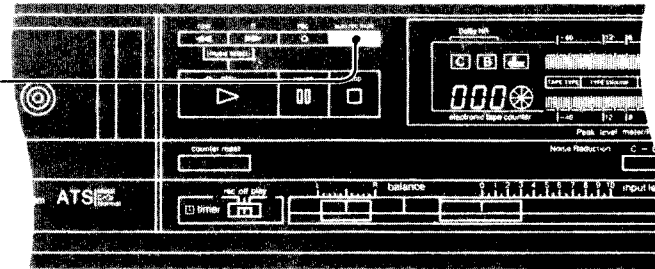
**DISASSEMBLY INSTRUCTIONS**

Ref. No. 1	How to remove the case cover	Ref. No. 3	How to remove the meter P.C.B.
Procedure 1	<ul style="list-style-type: none"> Remove the 4 screws (1~4). 	Procedure 1 → 3	<ul style="list-style-type: none"> Remove the 5 screws (1~5), and then remove the meter angle. Push the 4 tabs aside.
<p>Fig. 1</p>		<p>Fig. 3</p>	
Ref. No. 2	How to remove the main P.C.B.	Ref. No. 4	How to remove the mechanism unit
Procedure 1 → 2	<ul style="list-style-type: none"> Remove the screw (1), and then remove the AC inlet angle. Push the 4 tabs aside, and then pull down the back chassis. Remove the 2 screws (2, 3). Remove the 2 screws (4, 5), and then remove the earth plate. Pull the main P.C.B. in the direction of arrow A. 	Procedure 1 → 4	<ul style="list-style-type: none"> Push the eject button (see fig. 1). Remove the 2 screws (6, 7) (see fig. 3). Remove the 3 screws (1~3).
<p>Fig. 2</p>		<p>Fig. 4</p>	

DISASSEMBLY INSTRUCTIONS

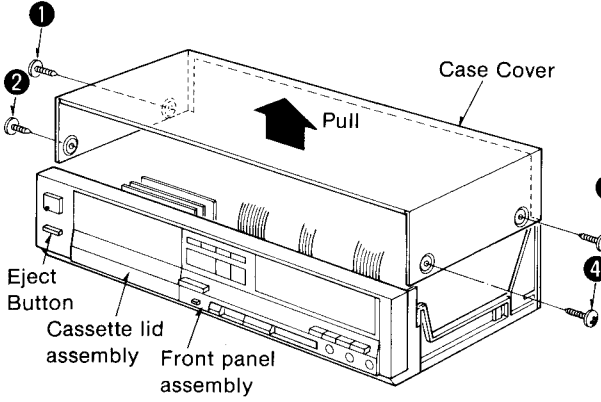
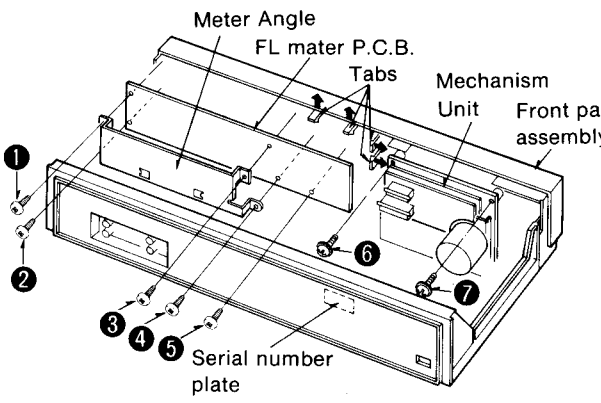
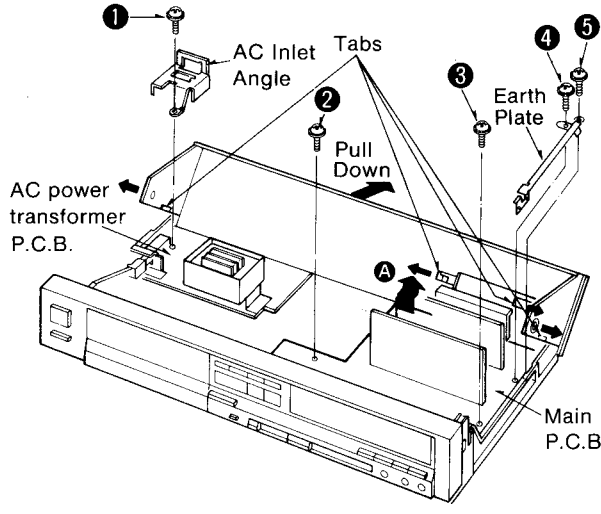
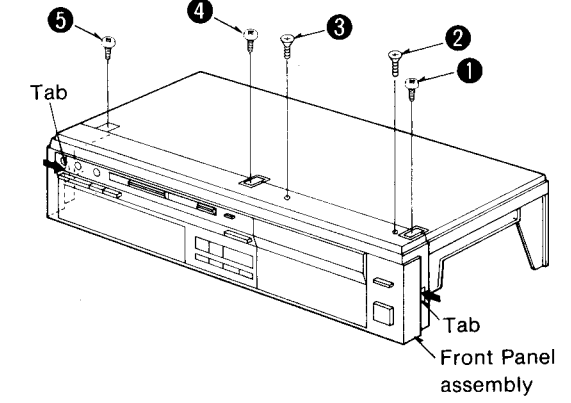
<p>Ref. No. 1</p>	<p>How to remove the case cover</p>	<p>Ref. No. 3</p>	<p>How to remove the meter P.C.B.</p>
<p>Procedure 1</p>	<ul style="list-style-type: none"> Remove the 4 screws (1~4).  <p>Fig. 1</p>	<p>Procedure 1 → 3</p>	<ul style="list-style-type: none"> Remove the 5 screws (1~5), and then remove the meter angle. Push the 4 tabs aside.  <p>Fig. 3</p>
<p>Ref. No. 2</p>	<p>How to remove the main P.C.B.</p>	<p>Ref. No. 4</p>	<p>How to remove the mechanism unit</p>
<p>Procedure 1 → 2</p>	<ul style="list-style-type: none"> Remove the screw (1), and then remove the AC inlet angle. Push the 4 tabs aside, and then pull down the back chassis. Remove the 2 screws (2, 3). Remove the 2 screws (4, 5), and then remove the earth plate. Pull the main P.C.B. in the direction of arrow A.  <p>Fig. 2</p>	<p>Procedure 1 → 4</p>	<ul style="list-style-type: none"> Push the eject button (see fig. 1). Remove the 2 screws (6, 7) (see fig. 3). Remove the 3 screws (1~3).  <p>Fig. 4</p>

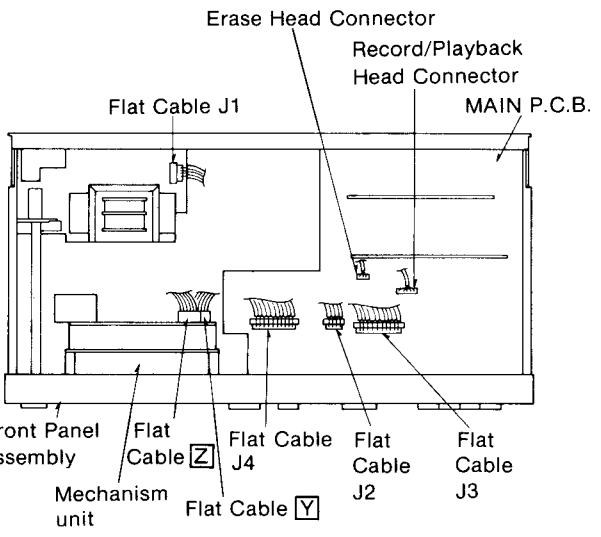
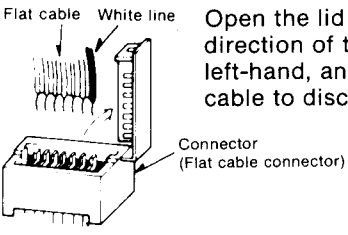
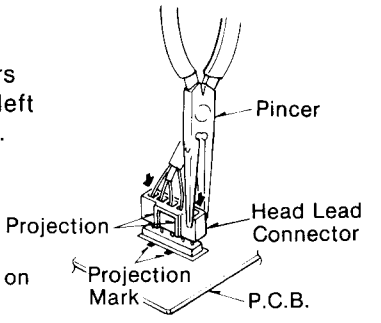
<p>Ref. No. 5</p>	<p>How to remove the front panel assembly</p>	 <p>Fig. 5</p>
<p>Procedure 1 → 5</p>	<ul style="list-style-type: none"> Remove the 3 screws (1, 2, 3) (see fig. 4). Remove the 4 flat cables (Y, J2, J3 and J4) (See fig. 5 and 6). Remove the 2 connectors (record/playback head connector and erase head connector) (see fig. 5 and 7). Push 2 tabs aside (see fig. 4). <p>How to remove flat cable</p>  <p>Fig. 6</p>	<ul style="list-style-type: none"> How to remove the head lead connector Pull the connector with pincers alternatively on the right and left sides as shown by the arrows. How to insert the head lead connector Match the projections of the connector with the marks printed on the P.C.B. and then insert the connector completely.  <p>Fig. 7</p>

*** Serial No. Indication**

- The serial number plate of this product is attached to back chassis. (shown in fig. 3).

MEASUREMENTS AND ADJUSTMENTS

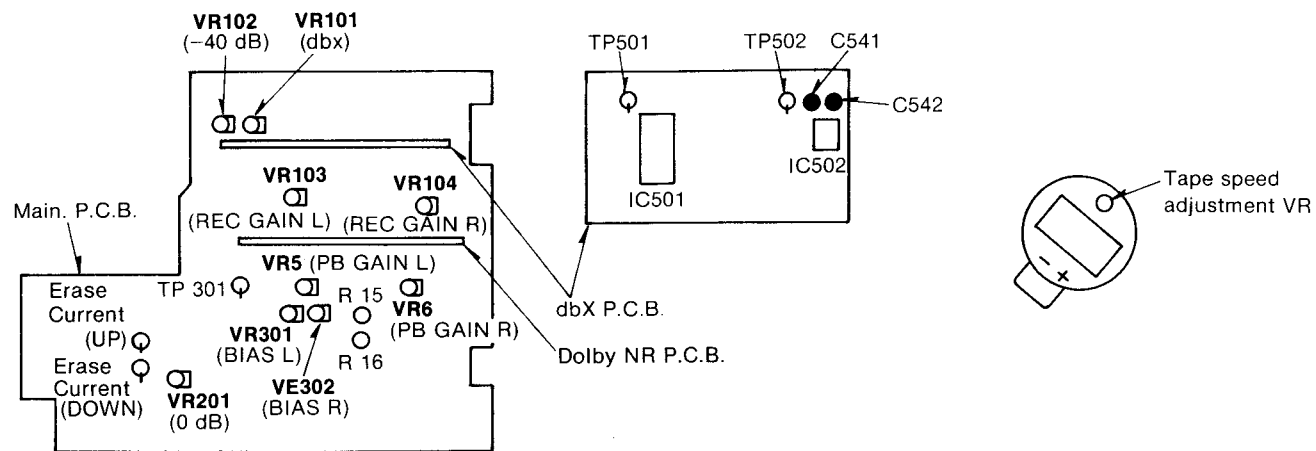

Fig. 1

NOTES: Set switches and controls in the following positions, unless otherwise specified.

- Make sure heads are clean
- Make sure capstan and pressure roller are clean
- Judgeable room temperature 20±5°C (68±9°F)
- Input level controls: Maximum
- Dolby NR switch: OUT
- Balance Control: Center

<p>A Head azimuth adjustment</p> <p>Condition: • Playback mode</p> <p>Equipment: • EVM (Electronic Voltmeter) • Oscilloscope • Test tape (azimuth)...QZZCFM</p>	<p>L-CH/R-CH output balance adjustment</p> <p>1. Make connections as shown in fig. 2.</p> <p>2. Playback the 8kHz signal from the test tape (QZZCFM). Adjust screw (B) in fig. 3 for maximum output L-CH and R-CH levels. When the output levels of L-CH and R-CH are not at maximum at the same point adjust as follows.</p> <p>3. Turn screw (B) shown in fig. 3 to find angles A and C (points where peak output levels for left and right channels are obtained). Then, locate angle B between angles A and C, i.e., point where L-CH and R-CH outputs are balanced. (Refer to figs. 3 and 4.)</p> <p>L-CH/R-CH phase adjustment</p> <p>4. Make connections as shown in fig. 5.</p> <p>5. Playback the 8kHz signal from the test tape (QZZCFM). Adjust screw (B) shown in fig. 3 so that pointers of the two EVMs swing to maximum and a lissajous waveform as illustrated in fig. 6 is obtained on the oscilloscope.</p>

<p>Tape speed</p> <p>Condition: • Playback mode</p> <p>Equipment: • Digital frequency counter • Test tape...QZZCWAT</p>	<p>Tape speed accuracy</p> <p>1. Test equipment connection is shown in fig. 7.</p> <p>2. Playback test tape (QZZCWAT 3,000Hz), and supply playback signal to the digital frequency counter.</p> <p>3. Measure this frequency.</p> <p>4. On the basis of 3,000Hz, determine value by following formula:</p> $\text{Tape speed accuracy} = \frac{f-3,000}{3,000} \times 100(\%) \quad \text{where, } f = \text{measured value}$ <p>5. Take measurement at middle section of tape.</p> <p style="text-align: center;">Standard value: ±0.33% (3000±10 Hz)</p> <p>6. If measured value is not within the standard value, adjust it by using the tape speed adjustment VR shown in fig. 1.</p> <p>Note: Please use non metal type screwdriver when you adjust tape speed accuracy on this unit.</p> <p>Tape speed fluctuation</p> <p>Make measurements in same manner as above (beginning, middle and end of tape), and determine the difference between maximum and minimum values and calculate as follows:</p> $\text{Tape speed fluctuation} = \frac{f_1-f_2}{3,000} \times 100(\%) \quad f_1 = \text{maximum value, } f_2 = \text{minimum value}$ <p style="text-align: center;">Standard value: Less than 1%</p>
<p>Playback frequency response</p> <p>Condition: • Playback mode</p> <p>Equipment: • EVM (Electronic Voltmeter) • Oscilloscope • Test tape...QZZCFM</p>	<p>1. Test equipment connection is shown in fig. 2.</p> <p>2. Playback the frequency response portion of test tape (QZZCFM).</p> <p>3. Measure output level at 315Hz, 12.5kHz, 8kHz, 4kHz, 1kHz, 250Hz, 125Hz and 63Hz, and compare each output level with the standard frequency 315Hz, at LINE OUT.</p> <p>4. Make measurements for both channels.</p> <p>5. Make sure that the measured values are within the range specified in the frequency response chart (Shown in fig. 8).</p>
<p>Playback gain</p> <p>Condition: • Playback mode</p> <p>Equipment: • EVM (Electronic Voltmeter) • Oscilloscope • Test tape...QZZCFM</p>	<p>1. Test equipment connection is shown in fig. 2.</p> <p>2. Playback standard recording level portion on test tape (QZZCFM 315Hz) and, using EVM, measure the output level at LINE OUTs.</p> <p>3. Make measurements for both channels.</p> <p style="text-align: center;">Standard value: 0.4V±0.5 dB (0.02V)</p> <p>Adjustment</p> <p>1. If the measured value is not within the standard, adjust VR5 (L-CH) or VR6 (R-CH). (See fig. 1.)</p> <p>2. After adjustment, check "Playback frequency response" again.</p>
<p>Erase current</p> <p>Condition: • Record mode</p> <p>Equipment: • EVM (Electronic Voltmeter) • Oscilloscope • Test tape (reference blank tape) ...QZZCRZ for Metal</p>	<p>1. Test equipment connection is shown in fig. 2.</p> <p>2. Insert the metal tape.</p> <p>3. Press the record button.</p> <p>4. Read voltage on the oscilloscope and calculate the formula:</p> <p style="text-align: center;">Standard value: 0.4V±0.5 dB (0.02V)</p> <p>5. If the measured value is not within the standard value, adjust VR5 (L-CH) or VR6 (R-CH). (See fig. 1.)</p> <p>6. After adjustment, check "Playback frequency response" again.</p>

1. Test equipment connection is shown in fig. 2.

2. Insert the metal tape.

3. Press the record button.

4. Read voltage on the oscilloscope and calculate the formula:

Standard value: 0.4V±0.5 dB (0.02V)

5. If the measured value is not within the standard value, adjust VR5 (L-CH) or VR6 (R-CH). (See fig. 1.)

6. After adjustment, check "Playback frequency response" again.

Adjustment

1. Short points (A and C) on the graph.

2. Measure the output level at these points.

3. If the erase current is not within the standard value, adjust VR5 (L-CH) or VR6 (R-CH). (See fig. 1.)

4. If the erase current is not within the standard value, adjust VR5 (L-CH) or VR6 (R-CH). (See fig. 1.)

Overall frequency response

Note: Before measuring overall frequency response make sure the method of measurement is correct.

(Recording equipment)

1. Make connections as shown in fig. 2.

2. Insert the test tape.

3. Supply a 1kHz signal to the LINE IN.

4. Adjust ATT (Attenuation) to the recording level.

5. Adjust the A (Amplitude) control to 200Hz, 500Hz and 1kHz and record the output level.

6. Playback the test tape and measure the overall frequency response.

(If the curve is not within the range specified in steps 7, 8 and 9, adjust VR5 (L-CH) or VR6 (R-CH) as follows;

Adjustment (A)

When the curve is not within the range specified in steps 7, 8 and 9, adjust VR5 (L-CH) or VR6 (R-CH) as follows;

1) Increase bias current by turning VR5 (L-CH) or VR6 (R-CH) clockwise.

2) Repeat steps 7, 8 and 9.

3) If the curve is still not within the range specified in steps 7, 8 and 9, increase the recording level by turning VR5 (L-CH) or VR6 (R-CH) clockwise.

Ⓔ Tape speed Condition: Playback mode Equipment: Digital frequency counter, Test tape...QZZCWAT

Tape speed accuracy
 1. Test equipment connection is shown in fig. 7.
 2. Playback test tape (QZZCWAT 3,000Hz), and supply playback signal to the digital frequency counter.
 3. Measure this frequency.
 4. On the basis of 3,000Hz, determine value by following formula:

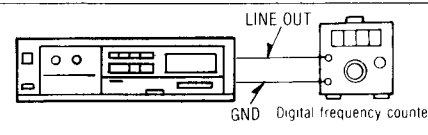

Fig. 7

$$\text{Tape speed accuracy} = \frac{f-3,000}{3,000} \times 100(\%) \quad \text{where, } f = \text{measured value}$$

Standard value: ±0.33% (3000±10 Hz)

5. Take measurement at middle section of tape.
 6. If measured value is not within the standard value, adjust it by using the tape speed adjustment VR shown in fig. 1.
Note: Please use non metal type screwdriver when you adjust tape speed accuracy on this unit.

Tape speed fluctuation
 Make measurements in same manner as above (beginning, middle and end of tape), and determine the difference between maximum and minimum values and calculate as follows:

$$\text{Tape speed fluctuation} = \frac{f_1-f_2}{3,000} \times 100(\%) \quad f_1 = \text{maximum value, } f_2 = \text{minimum value}$$

Standard value: Less than 1%

Ⓕ Playback frequency response Condition: Playback mode Equipment: EVM (Electronic Voltmeter), Oscilloscope, Test tape...QZZCFM

1. Test equipment connection is shown in fig. 2.
 2. Playback the frequency response portion of test tape (QZZCFM).
 3. Measure output level at 315Hz, 12.5kHz, 8kHz, 4kHz, 1kHz, 250Hz, 125Hz and 63Hz, and compare each output level with the standard frequency 315Hz, at LINE OUT.
 4. Make measurements for both channels.
 5. Make sure that the measured values are within the range specified in the frequency response chart (Shown in fig. 8).

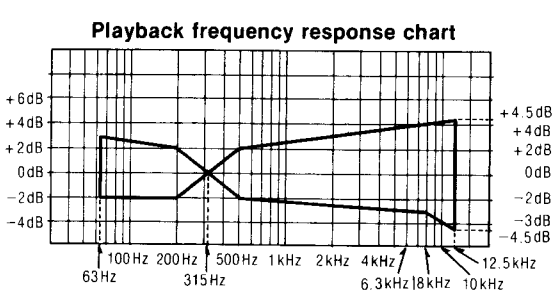

Fig. 8

Ⓖ Playback gain Condition: Playback mode Equipment: EVM (Electronic Voltmeter), Oscilloscope, Test tape...QZZCFM

1. Test equipment connection is shown in fig. 2.
 2. Playback standard recording level portion on test tape (QZZCFM 315Hz) and, using EVM, measure the output level at LINE OUTs.
 3. Make measurements for both channels.

Standard value: 0.4V±0.5 dB (0.02V)

Adjustment
 1. If the measured value is not within the standard, adjust VR5 (L-CH) or VR6 (R-CH). (See fig. 1.)
 2. After adjustment, check "Playback frequency response" again.

Ⓖ Erase current Condition: Record mode Equipment: EVM (Electronic Voltmeter), Oscilloscope, Test tape (reference blank tape) ...QZZCRZ for Metal

1. Test equipment connection is shown in fig. 9.
 2. Insert the metal tape.
 3. Press the record and pause buttons.
 4. Read voltage on EVM and calculate erase current by following formula:

$$\text{Erase current (A)} = \frac{\text{Voltage across resistor R301}}{1 (\Omega)}$$

Standard value: 155±15 mA (Metal) (155±15 mV)

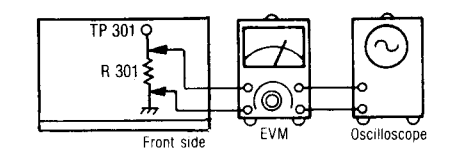

Fig. 9

5. If the measured value is not within the standard value adjust it by following the adjustment instructions.

Adjustment
 1. Short points (A) and (B) on the main circuit board. (See fig. 1)
 2. Measure the erase current.
 3. If the erase current is less than 140 mA, open the DOWN point (B).
 4. If the erase current is more than 170 mA, open the UP point (A).

Ⓖ Overall frequency response Condition: Record/playback mode, Input level controls...MAX Equipment: EVM (Electronic Voltmeter), ATT, AF oscillator, Oscilloscope, Resistor (600Ω), Test tape (reference blank tape) ...QZZCRA for Normal, ...QZZCRX for CrO2, ...QZZCRZ for Metal

Note:
 Before measuring and adjusting, the overall frequency response make sure of the playback frequency response (For the method of measurement, please refer to the playback frequency response).

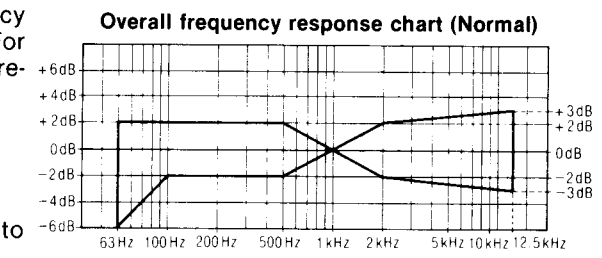

Fig. 10

(Recording equalizer is fixed)
 1. Make connections as shown in fig. 11.
 2. Insert the normal reference blank test tape (QZZCRA).
 3. Supply a 1kHz signal from the AF oscillator through ATT to LINE IN.
 4. Adjust ATT so that input level is -20dB below standard recording level (standard recording level = 0 VU).
 5. Adjust the AF oscillator frequency to 1kHz, 50Hz, 100Hz, 200Hz, 500Hz, 4kHz, 8kHz, 10kHz and 12.5kHz signals, and record these signals on the test tape.
 6. Playback the signals recorded in step 6, and check if the frequency response curve is within the limits shown in the overall frequency response chart for normal tapes (fig. 10). (If the curve is within the charted specifications, proceed to steps 7, 8 and 9.)
 If the curve is not within the charted specifications, adjust as follows;

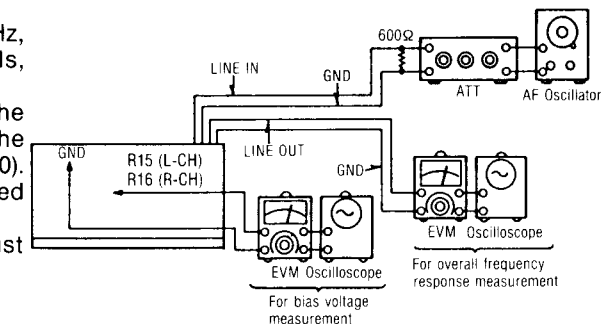

Fig. 11

Adjustment (A):
 When the curve exceeds the overall specified frequency response chart (fig. 10) as shown in fig. 12.

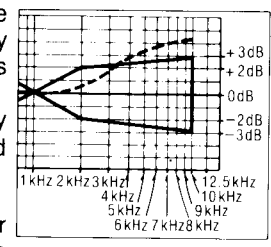

Fig. 12

1) Increase bias current by turning VR301 (L-CH) and VR302 (R-CH). (See fig. 1.)
 2) Repeat steps 5 and 6 for confirmation (Proceed to steps 7, 8 and 9 if the curve is now within the charted specifications as shown fig. 10.)
 3) If the curve still exceeds the specifications (fig. 10), increase bias current further and repeat steps 5 and 6.

Adjustment (B):
 When the curve falls below the overall specified frequency response chart (fig. 10) as shown in fig. 13.

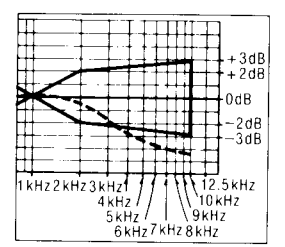

Fig. 13

1) Reduce bias current by turning VR301 (L-CH) and VR302 (R-CH).
 2) Repeat steps 5 and 6 for confirmation (Proceed to steps 7, 8 and 9 if the curve is now within the charted specifications as shown fig. 10.)
 3) If the curve still falls below the charted specifications (fig. 10), reduce bias current further and repeat steps 5 and 6.

7. Insert the CrO₂ tape.
8. Change test tape to CrO₂ reference blank test tape (QZZCRX), and record 1kHz, 50Hz, 100Hz, 200Hz, 500Hz, 4kHz, 8kHz, 10kHz and 15kHz signals. Then, playback the signals and check if the curve is within the limits shown in the overall frequency response chart for CrO₂ tapes (fig. 14).
9. Change test tape to metal reference blank test tape (QZZCRZ), and record 1kHz, 50Hz, 100Hz, 200Hz, 500Hz, 4kHz, 8kHz, 10kHz, 12.5kHz and 15kHz signals. Then, playback the signals and check if the curve is within the limits shown in the overall frequency response chart for metal tapes (fig. 14).
10. Confirm that bias currents are approximately as follows when the UNIT is set at different tape mode.
 - Read voltage at the terminals of resistor R15 (L-CH) {R16 (R-CH)}, and calculate bias current by following formula:

Overall frequency response chart (CrO₂, Metal)

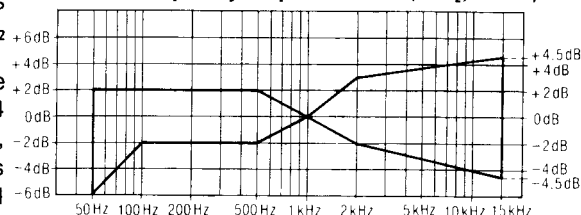

Fig. 14

$$\text{Bias current (A)} = \frac{\text{Value read on EVM (V)}}{10 (\Omega)}$$

Reference value:
 around 170 μA (Normal position)
 around 200 μA (CrO₂ position)
 around 370 μA (Metal position)

Ⓒ Overall gain

Condition:

- Record/playback mode
- Input level controls...MAX
- Standard input level;
 - MIC -72 +5 dB dB
 (0.25 mV)
 - LINE IN -24 ± 4 dB
 (63 mV)

Equipment:

- EVM (Electronic Voltmeter)
- ATT
- Resistor (600Ω)
- Test tape (reference blank tape) ...QZZCRA for Normal
- AF oscillator
- Oscilloscope

1. Test equipment connection is shown in fig. 15.
2. Insert the normal reference blank tape (QZZCRA).
3. Place UNIT into record mode.
4. Supply a 1kHz signal through ATT (-24dB) from AF oscillator, to LINE IN.
5. Adjust ATT until monitor level at LINE OUT becomes 0.4 V ± 0.5 dB (0.02 V)
6. Playback recorded tape, and make sure that the output level at LINE OUT becomes 0.4 V ± 0.5 dB (0.02 V)
7. If measured value is not 0.4 V ± 0.5 dB (0.02 V), adjust it by using VR103 (L-CH) or VR104 (R-CH).
8. Repeat from step (2).

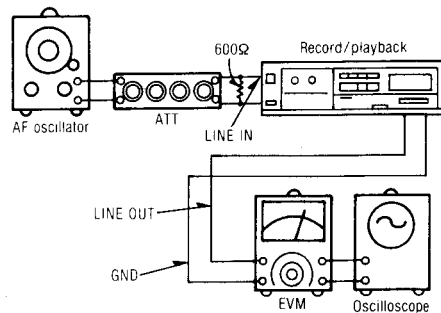

Fig. 15

Ⓓ Fluorescent meter

Condition:

- Record mode
- Input level controls...MAX

Equipment:

- EVM (Electronic Voltmeter)
- ATT
- Resistor (600Ω)
- AF oscillator
- Oscilloscope

1. Make connections as shown in fig. 16.
2. In the recording pause mode, apply 1kHz (-24dB) to LINE IN.
3. Adjust ATT so that output level at LINE OUT is 0.4 V ± 0.5 dB (0.02 V).
-40 dB adjustment
4. Adjust ATT so that the level adjusted at step 3 is reduced by 40 dB.
5. At this time, check that -40 dB indicator is dimmed (intermediate brightness between full brightness and light-out: See fig. 17).
6. If the indicator is not lighted halfway as described in step 6, adjust VR102.

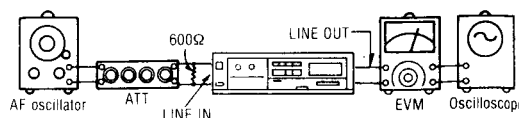

Fig. 16

0 dB adjustment

7. Restore the condition of step 3 (set output level to $0.4V \pm 0.5dB$ (0.02V) at LINE OUT.
8. At this time, check that 0 dB indicator is dimmed (intermediate brightness between full brightness and light-out (See fig. 18.)
9. If improper, adjust VR201.
10. Repeat adjustments at steps 3, 4, 5, 6, 7, 8 and 9 two or three times.

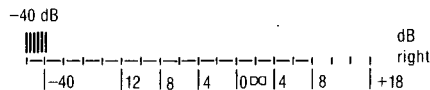

Fig. 17

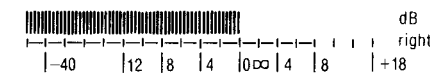

Fig. 18

1 Dolby NR circuit

Condition:

- Record mode
- Dolby NR switch...IN/OUT
- Dolby NR select switch ...B/C
- Input level controls...MAX

Equipment:

- EVM (Electronic Voltmeter)
- ATT
- Resistor (600Ω)
- AF oscillator
- Oscilloscope

Record side

• Check of the Dolby-B type encoder characteristics

1. Make connections as shown in fig. 19.
2. Set the unit to record mode. (NR select switch is OUT.)
3. Apply a 1kHz signal to LINE IN.
4. Adjust the ATT so that the output level at Pin 7 of IC 401 (L-CH) and IC 402 (R-CH) is 12.3 mV.
5. The output level at pin 21 should be 0dB. (375mV).
6. Set the NR select switch to B, and make sure that the output signal level at pin 21 of IC 401 (L-CH) and IC 402 (R-CH) is $+6 \pm 1.5$ dB. (753 mV)
7. Set the NR select switch to OUT, and adjust the frequency to 5kHz. The output signal level at pin 21 should be 0dB. (375mV).
8. Set the NR select switch to B and make sure that the output signal level at pin 21 of IC 401 (L-CH) and IC 402 (R-CH) is $+8 \pm 1.5$ dB. (948mV)

• Check to Dolby-C type encoder characteristics

1. Repeat steps 1-5 above.
2. Set the NR select switch to C and make sure that the output signal level at pin 21 of IC 401 (L-CH) and IC 402 (R-CH) is $+11.5 \pm 2$ dB. (1.4V)
3. Set the NR select switch to OUT and adjust the frequency to 5kHz. The output signal at pin 21 should be 0dB.
4. Set the NR select switch to C and make sure that the output signal level at pin 21 of IC 401 (L-CH) and IC 402 (R-CH) is $+8.5 \pm 2$ dB. (1V)

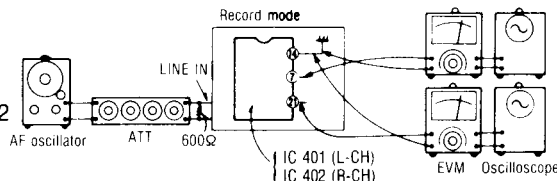

Fig. 19

1 Attack recovery time adjustment (dbx circuit)

Condition:

- Record mode
- Input level control...MAX
- Noise reduction selector ...dbx

Equipment:

- EVM (Electronic Voltmeter)
- ATT
- AF oscillator
- DC voltmeter

1. Make the connections as shown in fig. 20 and apply 1kHz -27dB signal from LINE IN, and set the noise reduction selector to dbx position.
2. Set the unit to record mode, adjust ATT so that the signal level at C541 (L-CH) and C542 (R-CH) is 300mV.
3. Read voltage on DC volt meter.

Reference value: 15 ± 0.5 mV

4. If measured value is not within reference, adjust VR101 (shown in fig. 1).

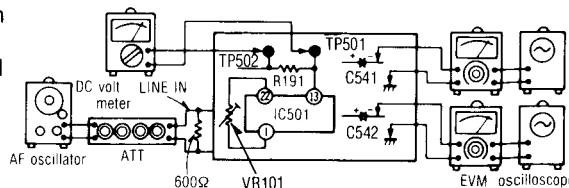

Fig. 20

■ MICROCOMPUTER TERMINAL FUNCTION AND WAVE FORM (IC901: LM6417E1825) * This micro-computer is used for mechanical operation.

Terminal No.	Symbol	Name	Function/operation
1.	PDφ	Rec Indication Output	<ul style="list-style-type: none"> • "L" level on receiving REC command. • "H" level Apporx. 0.2sec. after STOP command. • "L" level immediately after power ON in Timer REC.
2.	PD1	Rec Mute	<ul style="list-style-type: none"> • In REC PAUSE mode, "H" with AUTO REC MUTE button pressed; "L" with the button released. • In REC play mode, (1) "H" with AUTO REC MUTE button pressed; the mode changes to REC PAUSE, Apporx. 4.5sec. later, and then the level is "L". <ul style="list-style-type: none"> (2) When AUTO REC MUTE button is pressed for Apporx. 4.5sec. or over, the mode changes to REC PAUSE with AUTO REC MUTE button released, and then the level is "L". (3) When PLAY button is pressed within Apporx. 4.5sec. after pressing AUTO REC MUTE button, the mode changes to REC PLAY, and then the level is "L".
3.	PD2	—	• Non Connection.
4.	PD3	Play Indication Output Pause Indication Output MS Indication Output	<ul style="list-style-type: none"> • "L" on receiving play command. • "H" Apporx. 0.2sec. after STOP command. • "L" immediately after POWER ON in Timer Play. <ul style="list-style-type: none"> • "L" and "H" are repeated at Apporx. 1sec. cycle on receiving PAUSE command. • "H" on receiving STOP command. <ul style="list-style-type: none"> • "L" and "H" are repeated at Apporx. 0.16sec. cycle on receiving MS command.

Terminal No.	Symbol	Name	Function/operation
5.	OSC	Clock Oscillation	<ul style="list-style-type: none"> • Clock oscillation of about 120kHz. Note: Do not connect anything to this terminal during other measurement because it will be otherwise affected by the probe.
6.	PEφ	Audio Muting	<ul style="list-style-type: none"> • Shifted from STOP to PLAY, "L" Apporx. 0.7sec. after PLAY command. • Shifted from PAUSE to PLAY, "L" Apporx. 0.5sec. after PLAY command. • Shifted from STOP to REC PAUSE, "L" Apporx. 0.5sec. after REC command. • Shifted from MS to PLAY, "L" Apporx. 0.8sec. after PLAY command.
7.	PE1	Motor Output	• "H" in STOP mode, "L" in other modes.
8.	PE2	FF/REW Plunger Output	<ul style="list-style-type: none"> • "L" for a short time during FF/REW/MS changeover. <p>(1) STOP → FF → STOP</p> <p>(2) STOP → REW → STOP</p> <p>(3) PLAY → MS (FF) → PLAY/STOP</p> <p>(4) PLAY → MS (REW) → PLAY/STOP</p>

Terminal No.	Symbol	Name	Function/operation
9.	PE3	PLAY Plunger Output	<ul style="list-style-type: none"> • "L" for a short time during PLAY/REC PLAY/MS changeover. (1) STOP → PLAY → STOP/PAUSE <p>(2) PAUSE/REC PAUSE → PLAY/REC PLAY</p> <p>(3) MS (FF/REW) → PLAY</p> <p>(4) MS (FF/REW) → STOP</p>
10.	TEST	TEST	• Connection to GND.
11.	V _{SS}	—	• Connection to GND.
12.	INT	Reel Table Pulse Input	<ul style="list-style-type: none"> • Rotation of reel table (with ring, magnet) is detected by Hall IC (DN6838-S) to judge the tape end. • Rectangular wave input in PLAY, FF, REW, MS.
13.	RST	Reset Terminal	<ul style="list-style-type: none"> • Used to reset the microcomputer when power is thrown in. • Reset at "L" level (0.3 volt or less).
14.	V _{DD}	Power Supply Terminal	• Operative on 5.2 volts.
15.	PA ϕ	Key Input REW (S706) TIMER (S1)	<ul style="list-style-type: none"> • Input of REW, Timer REC, MS, FF/REW switch. • The above-mentioned inputs are read in accordance with PCϕ, PC1, PC2, PC3 scanning.
16.	PA1	Key Input FF (S707) TIMER (S1) PLAY (S901)	<ul style="list-style-type: none"> • Input of FF, Timer PLAY, switch. • The above-mentioned inputs are read in accordance with PCϕ, PC1, PC2 scanning.

Terminal No.	Symbol	Name	Function/operation
17.	PA2	Key Input PAUSE (S708) REC (S710) AUTO REC MUTE (S705) REC INH. (S904)	<ul style="list-style-type: none"> • Input of PAUSE, REC, AUTO REC MUTE, REC INH. switch. • The above-mentioned inputs are read in accordance with PCϕ, PC1, PC2, PC3 scanning.
18.	PA3	Key Input PLAY (S709) STOP (S711)	<ul style="list-style-type: none"> • Input of PLAY, STOP switch. • The above-mentioned inputs are read in accordance with PC1, PC2 scanning.
19.	PC ϕ	Input Switch Scanning	<p>Note: (1) During scan signal measurement, dull up between pins (19~22) and V_{DD} with about 10kΩ resistance. (2) There are 2 types of scans of PC3. (For MS detection)</p>
20.	PC1		
21.	PC2		
22.	PC3		

(IC701: LM6417E589)

* This micro-computer is used for tape counter operation.

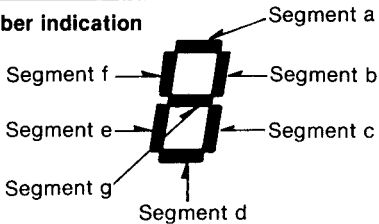
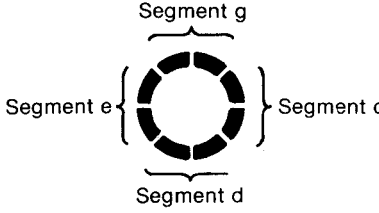
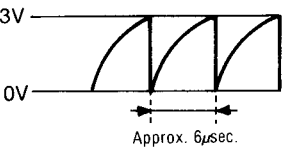
Terminal No.	Symbol	Name	Function/operation
1.	PD ϕ	FL Counter Segment a	<p>Number indication</p>  <p>Running indication</p> 
2.	PD 1	FL Counter Segment b	
3.	PD 2	FL Counter Segment c	
4.	PD 3	FL Counter Segment d	
5.	OSC	Oscillation Terminal	<ul style="list-style-type: none"> • Clock oscillation of about 120 kHz.  <p>Note) Do not connect anything to this terminal during other measurement because it will be otherwise affected by the probe.</p>
6.	PE ϕ	FL Counter Segment e	<ul style="list-style-type: none"> • Refer to PD ϕ~PD 3.
7.	PE 1	FL Counter Segment f	
8.	PE 2	FL Counter Segment g	
9.	PE 3	_____	<ul style="list-style-type: none"> • Non connection.
10.	TEST	TEST	<ul style="list-style-type: none"> • Connection to GND.
11.	Vss	_____	<ul style="list-style-type: none"> • Connection to GND.
12.	INT	_____	<ul style="list-style-type: none"> • Non connection.
13.	RST	Reset Terminal	<ul style="list-style-type: none"> • Used to reset the microcomputer when power is thrown in. • Reset at "L" level (0.3 V_{DD} or less).

Terminal No.	Symbol	Name	Function/operation
14.	VDD	Power Supply Terminal	<ul style="list-style-type: none"> • Operative on approx. 5.2 volts.
15.	PA ϕ	_____	<ul style="list-style-type: none"> • Non connection
16.	PA 1	Counter Reset Input	<ul style="list-style-type: none"> • In "L" level, counter indication is reset to <i>888</i>
17.	PA 2	Counter Up/Down Input	<ul style="list-style-type: none"> • Up counting with "H" level. • Down counting with "L" level.
18.	PA 3	Reel Table Pulse	<ul style="list-style-type: none"> • The rotation of reel table (with ring magnet) is detected by Hall IC (DN 6838-S), and the pulses are used to carry up or down for the counter. • With the takeup reel table rotated twice, the count number changes, and with it rotated 1/2, the running indication changes by one.
19.	PC ϕ	FL Grid 1 & Input Scan	<p>Approx. 7msec.</p>
20.	PC 1	FL Grid 2 & Input Scan	
21.	PC 2	FL Grid 3 & Input Scan	
22.	PC 3	FL Grid 4 & Input Scan	

■ BLOCK DIAGRAM

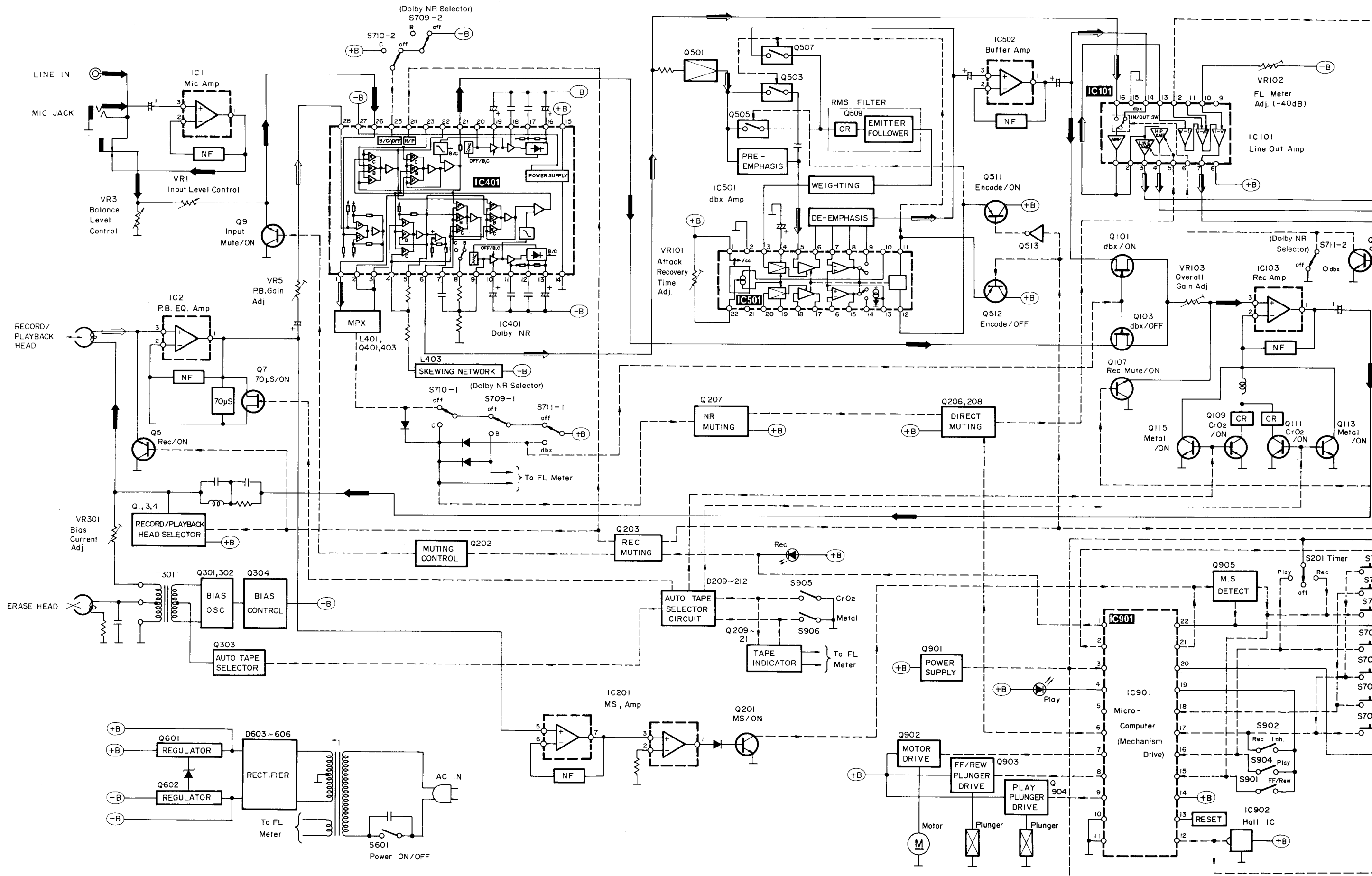

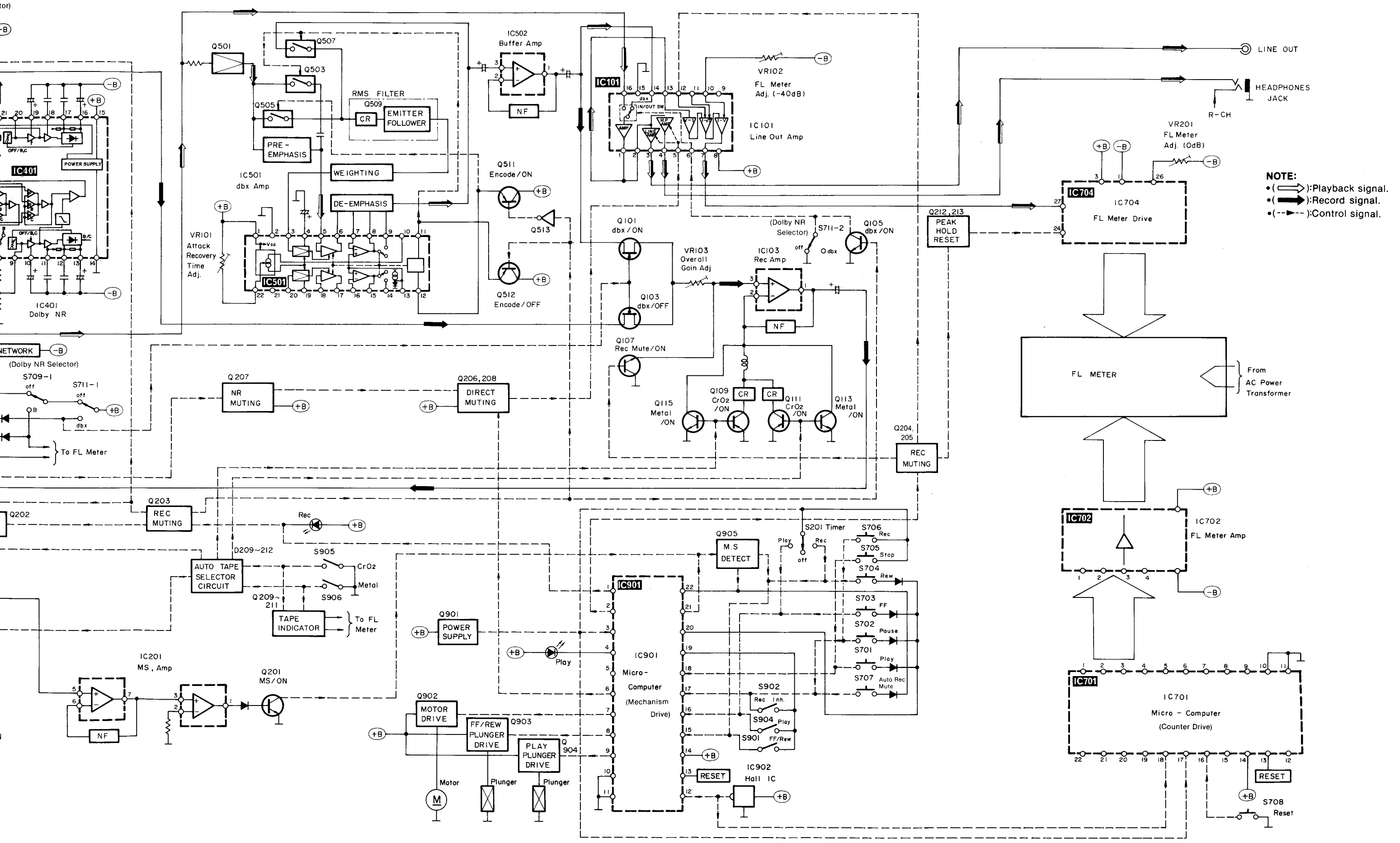

NOTE:
 • (→): Playback signal.
 • (- - -): Record signal.
 • (· · ·): Control signal.

ELECTRICAL PARTS LIST

NOTES:

Table listing various resistor types and capacitor types with their respective materials and codes.

Areas
* [M] For U.S.A.
* [E] For European areas except United Kingdom.
* [EK] For United Kingdom.
* [XA] For Asia, Latin America, Middle East and Africa.
* [XL] For Australia.
* [EGA] For F.R. Germany.
* [EH] For Holland.

REPLACEMENT PARTS LIST

Important safety notice
Components identified by Δ mark have special characteristics important for safety.
When replacing any of these components, use only manufacturer's specified parts.

RESISTORS

Large table listing various resistor part numbers, values, and descriptions.

CAPACITORS

Table listing various capacitor part numbers, values, and descriptions.

Table listing various integrated circuit part numbers, values, and descriptions.

Table listing various diodes, transistors, transformers, switches, variable resistors, combination parts, and connectors.

Change of Part List (RS-955 from RS-B55)

Table showing the change of part numbers from RS-B55 to RS-955 for various components.

NOTES:

- S201 : Timer switch
• S601 : Power Co
• S602 : AC Power [For [EK]
• S701 : Play switch
• S702 : Pause switch
• S703 : Fast forward
• S704 : Rewind
• S705 : Stop switch
• S706 : Rec switch
• S707 : Auto reverse
• S708 : Reset switch
• S709~S711 : NR S71 S70

EQUIVALENT IC 704: AN

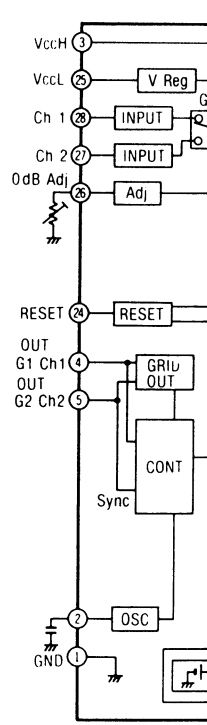

Table with columns: Ref. No., Part No., Value. Lists electronic components like resistors and capacitors.

Kingdom.
East and Africa.

Table with columns: Part No., Value. Lists resistor values for various part numbers.

Table with columns: Part No., Value. Lists capacitor values for various part numbers.

Main parts list table with columns: Ref. No., Part No., Part Name & Description. Includes categories like INTEGRATED CIRCUITS, TRANSISTORS, DIODES & RECTIFIERS, COILS, TRANSFORMERS, SWITCHES, VARIABLE RESISTORS, COMBINATION PARTS, JACKS, and CONNECTORS.

Change of Part List (RS-955 from RS-B55)

Table showing changes in part numbers and descriptions. Example: C607 (ECKD2H682PE) to Capacitor, TI (SLT5L225S) to AC Power Transformer.

NOTES:

- S201 : Timer switch in "OFF" position.
•S601 : Power ON/OFF switch in "OFF" position.
•S602 : AC power voltage selector.
[For [EK] [XA] [XL] mark areas.]
•S701 : Play switch in "OFF" position.
•S702 : Pause switch in "OFF" position.
•S703 : Fast forward switch in "OFF" position.
•S704 : Rewind switch in "OFF" position.
•S705 : Stop switch in "OFF" position.
•S706 : Rec switch in "OFF" position.
•S707 : Auto rec mute switch in "OFF" position.
•S708 : Reset switch in "OFF" position.
•S709~S711 : NR select switch (S709 - : B, S710 - : C, S711 - : dbx, S709~S711 ■ : OUT)
•S901 : Play mode switch in "OFF" position.
•S902 : FF/REW mode switch in "OFF" position.
•S904 : Rec inhibit switch in "OFF" position.
•S905 : Auto tape selector (for CrO2 tape).
•S906 : Auto tape selector (for Metal tape).

- (—) indicates B (bias).
• (•••••) indicates the flow of the playback signal.
• (•••••) indicates the flow of the recording signal.
• Important safety notice
Components identified by Δ mark have special characteristics important for safety. When replacing any of these components, use only manufacturer's specified parts.
• The part No. of transistors, IC and diodes mentioned in the schematic diagram stand for production part No. Regarding the part No. with ⚡ mark, the production part No. are different from the replacement part No. Therefore, when placing an order for replacement part, please use the part No. in the replacement part list.

* Caution !
IC and LSI are sensitive to static electricity. Secondary trouble can be prevented by taking care during repair.
* Cover the parts boxes made of plastics with aluminum foil.
* Ground the soldering iron.
* Put a conductive mat on the work table.
* Do not touch the legs of IC or LSI with the fingers directly.

EQUIVALENT CIRCUIT IC 704: AN6870N

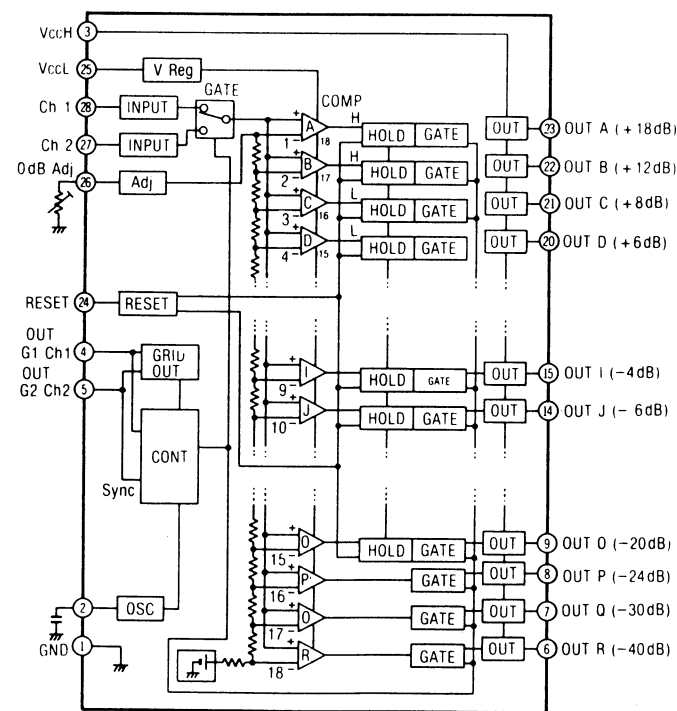

SPECIFICATIONS table with columns: Specification, Value. Includes Playback S/N ratio, Overall distortion, Overall S/N ratio.

SCHEMATIC DIAGRAM

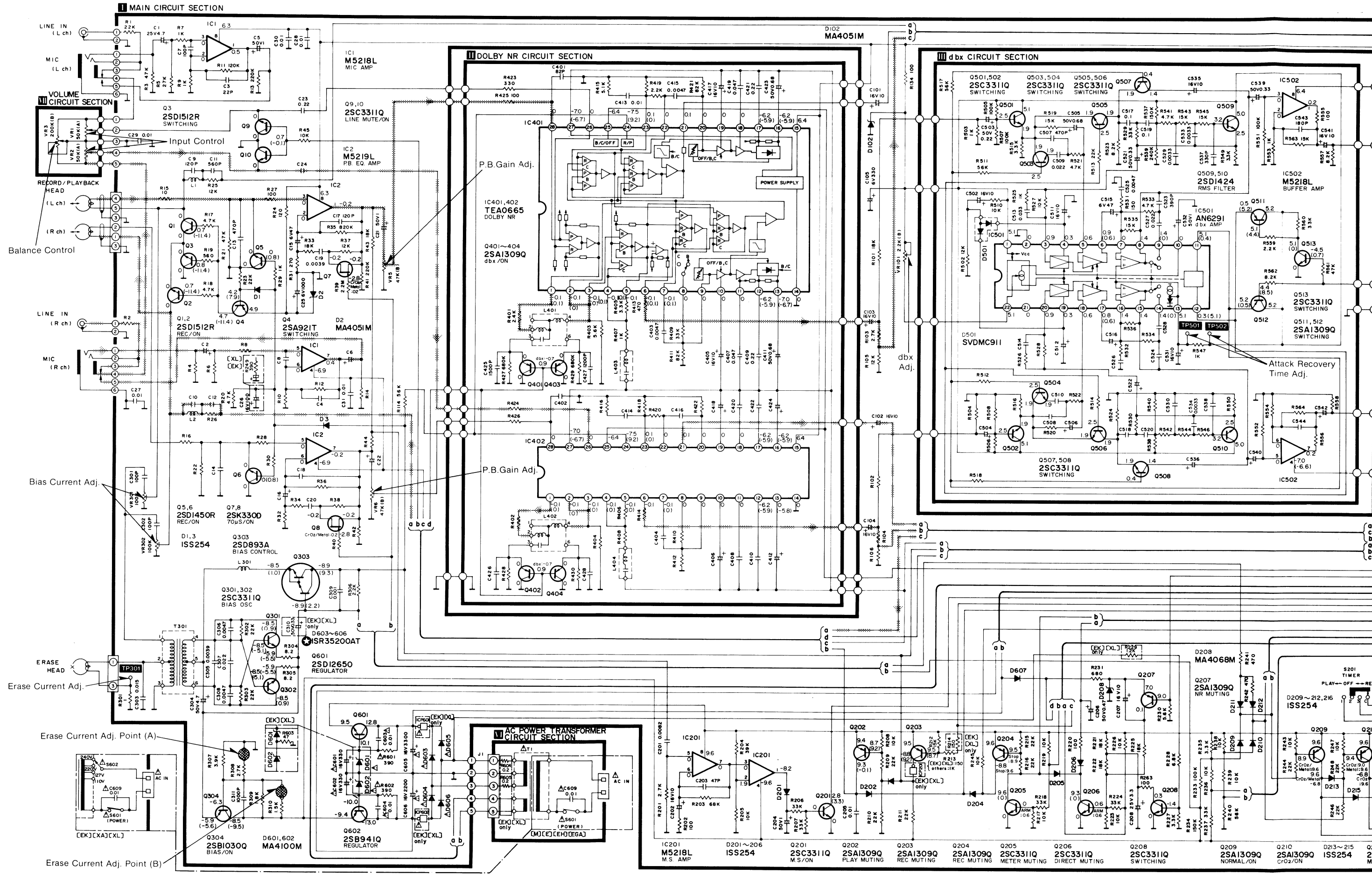

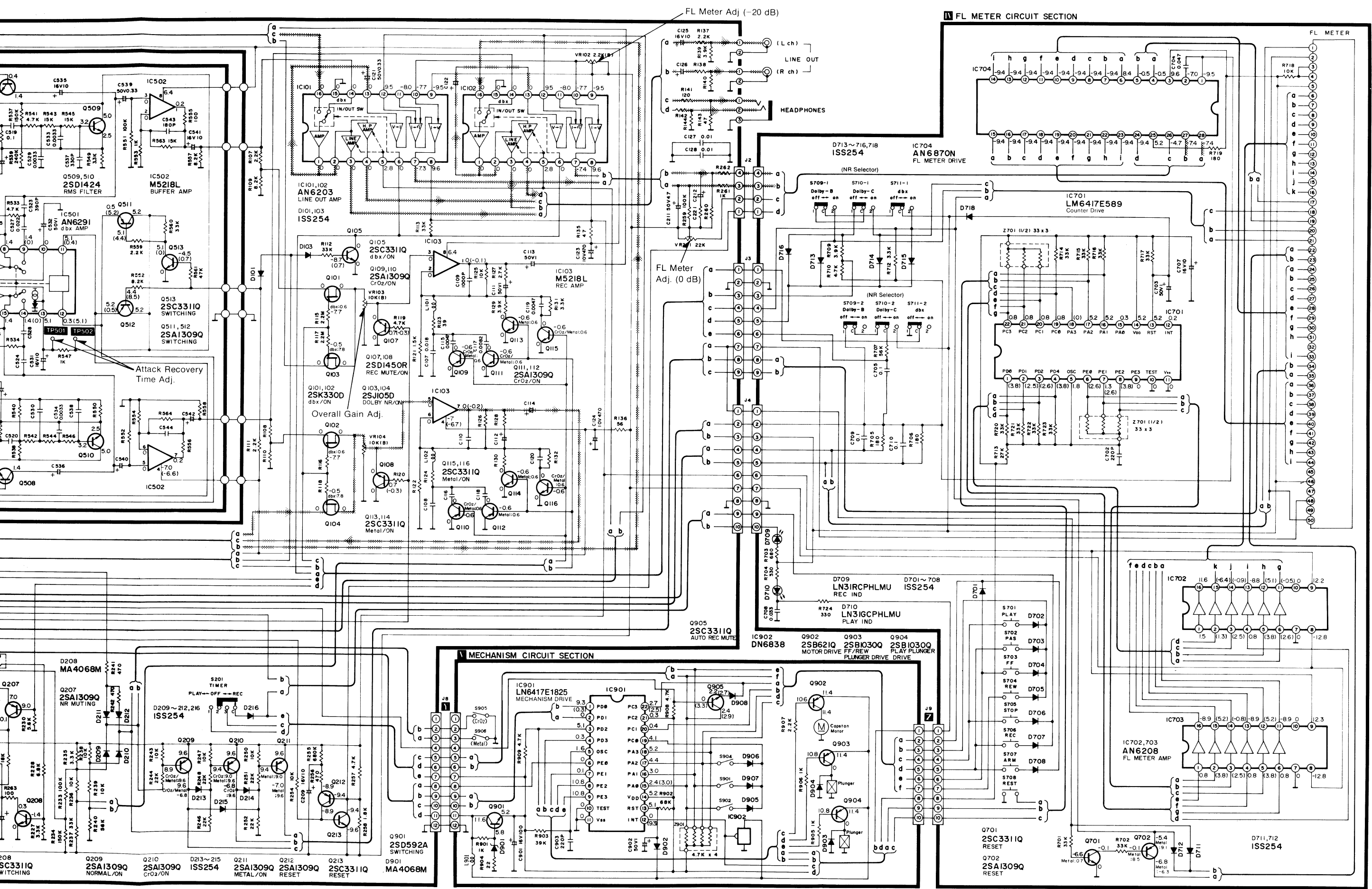

CIRCUIT BOARDS AND WIRING CONNECTION DIAGRAM

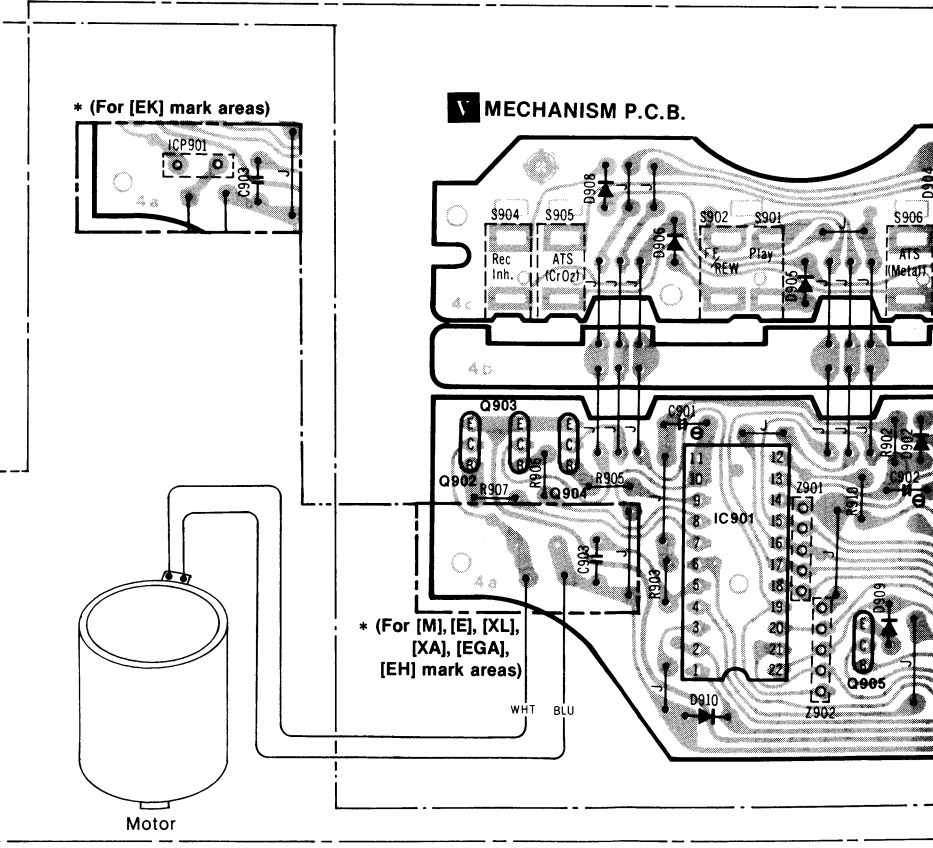
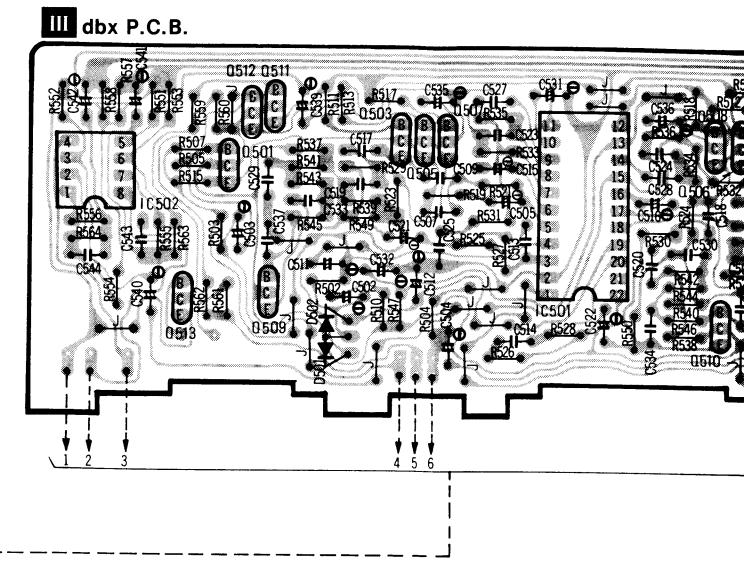
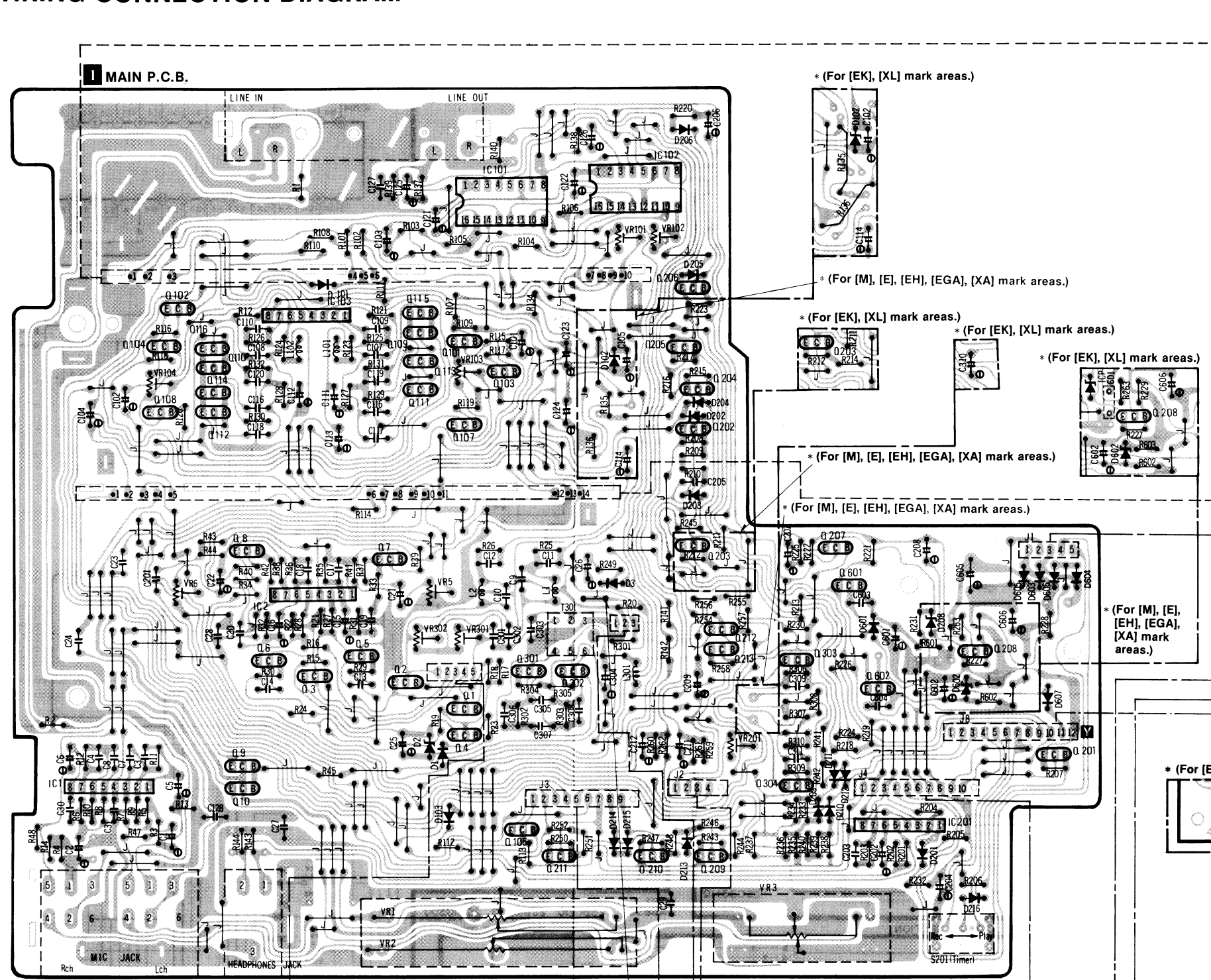

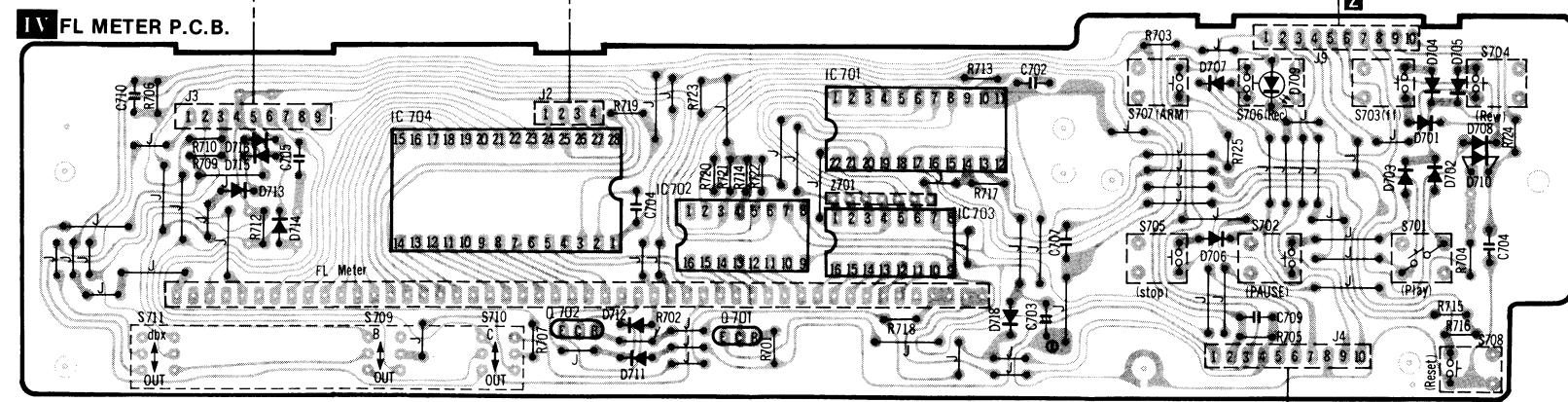
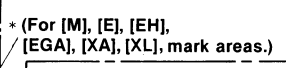
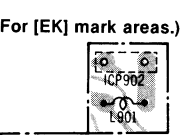
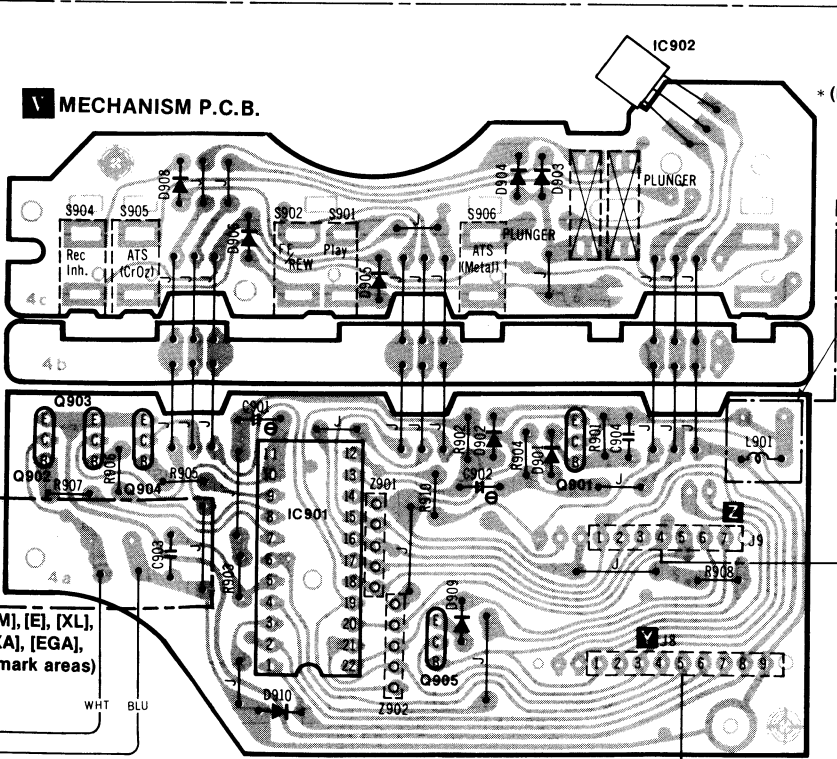
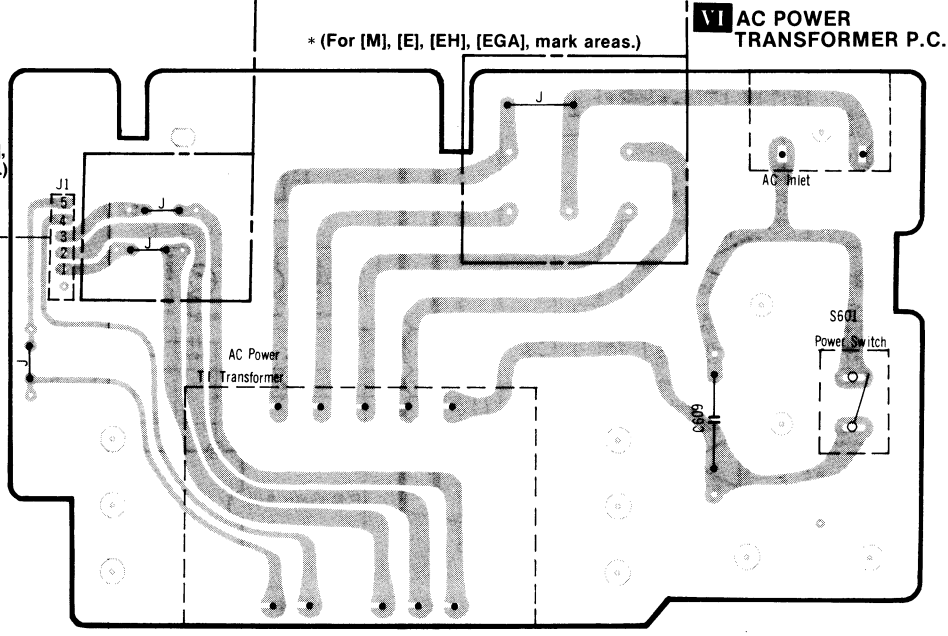
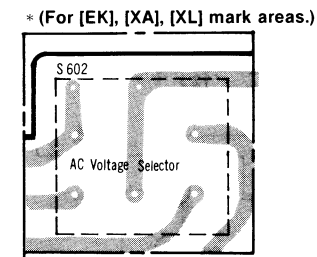
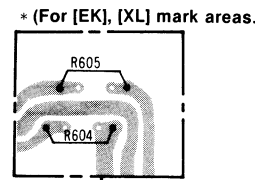
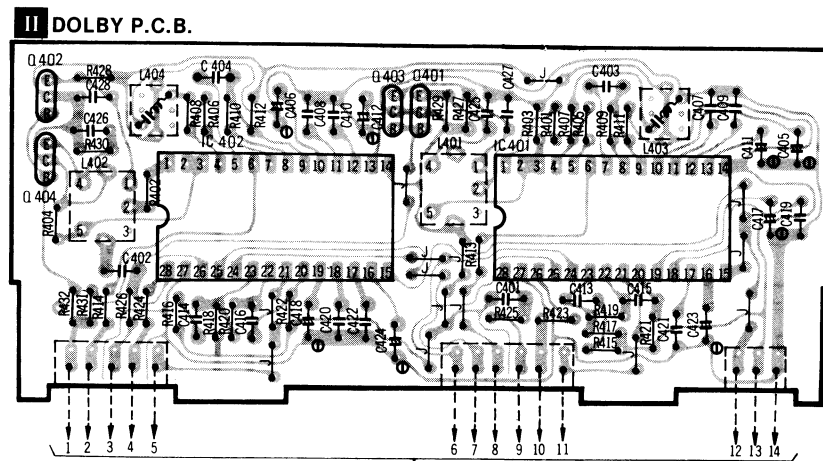
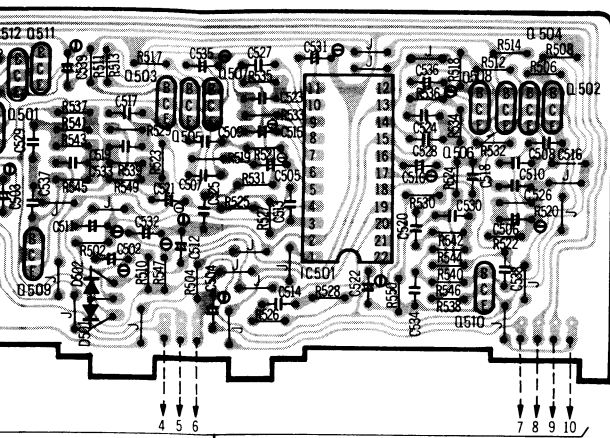

[M], [E], [XL], [XA], [EGA], mark areas)

■ TERMINAL GUIDE OF TRANSISTORS, DIODES, COILS, AND IC'S

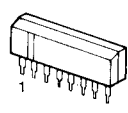
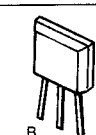
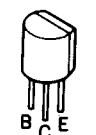
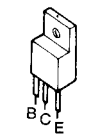
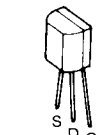
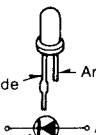
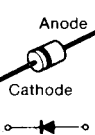
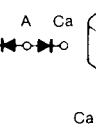
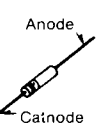
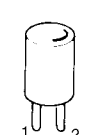
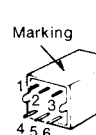
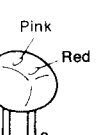
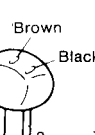
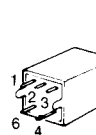
M5218L, M5219L 	<table border="1"> <tr><td>M5218P</td><td>8 Pin</td></tr> <tr><td>AN6203</td><td>11 Pin</td></tr> <tr><td>AN6280</td><td>11 Pin</td></tr> <tr><td>LM6417E-589</td><td>22 Pin</td></tr> <tr><td>AN6291</td><td>22 Pin</td></tr> <tr><td>AN6870N</td><td>28 Pin</td></tr> <tr><td>TEA0665</td><td>28 Pin</td></tr> </table>		M5218P	8 Pin	AN6203	11 Pin	AN6280	11 Pin	LM6417E-589	22 Pin	AN6291	22 Pin	AN6870N	28 Pin	TEA0665	28 Pin
M5218P	8 Pin															
AN6203	11 Pin															
AN6280	11 Pin															
LM6417E-589	22 Pin															
AN6291	22 Pin															
AN6870N	28 Pin															
TEA0665	28 Pin															
2SA1115E, 2SB1030Q, 2SA921Q, 2SC2603EFG, 2SD1512R, 2SD1424R 	2SD1468R 	2SB941Q, 2SD1265O 														
2SK381D, 2SJ40D 	LN31GCPHCLMU 	SM112, ISS254 														
SVDMC911 	MA4051M, MA4100M, MA4068M 	QLQX0343KWA 														
SLO9C19K 	QLQX2722D 	QLQX1012DT 														
ELM7Q306A, QLM9Z10K 	<table border="1"> <tr><td>CN1</td><td>SJS5421</td><td>4Pin</td></tr> <tr><td>CN2</td><td>SJS5519</td><td>5Pin</td></tr> <tr><td>CN3</td><td>SJS5903</td><td>9Pin</td></tr> <tr><td>CN4</td><td>SJS1989</td><td>10Pin</td></tr> </table>		CN1	SJS5421	4Pin	CN2	SJS5519	5Pin	CN3	SJS5903	9Pin	CN4	SJS1989	10Pin		
CN1	SJS5421	4Pin														
CN2	SJS5519	5Pin														
CN3	SJS5903	9Pin														
CN4	SJS1989	10Pin														

■ CABINET PARTS LOCATION

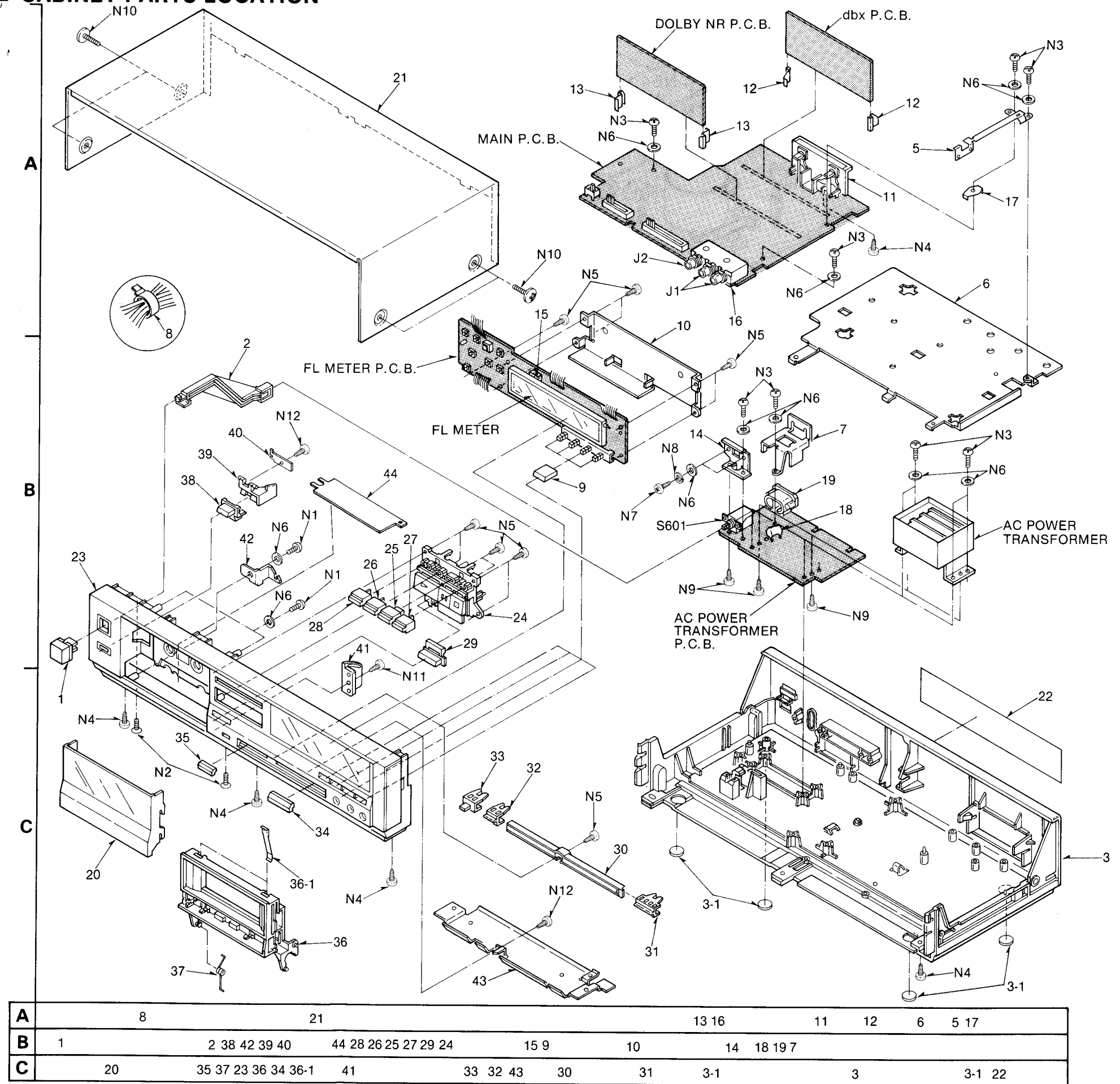

REPLACEMENT
Important safety
Components id
characteristics i
When replacin
only manufactur

Ref. No.	Pa
CABINET PA	
1	SBC
2	SUB2
3 [E][EH]	SKM
3 [EGA]	SKM
3 [EK]	SKM
3 [XA][XL]	SKM
3-1	SKL2
5	SUS7
6	SMC
7	SMN
8	QTD
9	SBC7
9	"Blac
9	SBC7
9	"Sive
10	SMN
11	OEJ5
12	SMN
13	SME
14	SMN
15	SHG
16	SMN
17	SNE5
18	SMX
19 [E]	
19 [EK][EH]	
19 [EGA]	
19 [XA] Δ	SJS9
19 [XL] Δ	SJS9
20	SGE1
20	"Blac
20	SGE1
20	"Sive
21	SKC1
21	"Blac
21	SKC1
21	"Sive
22[E][EH]	
22 [EGA]	SGT3
22 [EK]	SGT3
22 [XA]	SGT3
22 [XL]	SGT3

• Change

Ref. No.	Part
CABINET	
9	
18	
20	
22	
ACCESSORIES	
A1	
A2	
PACKAGING	
P1	

LOCATION

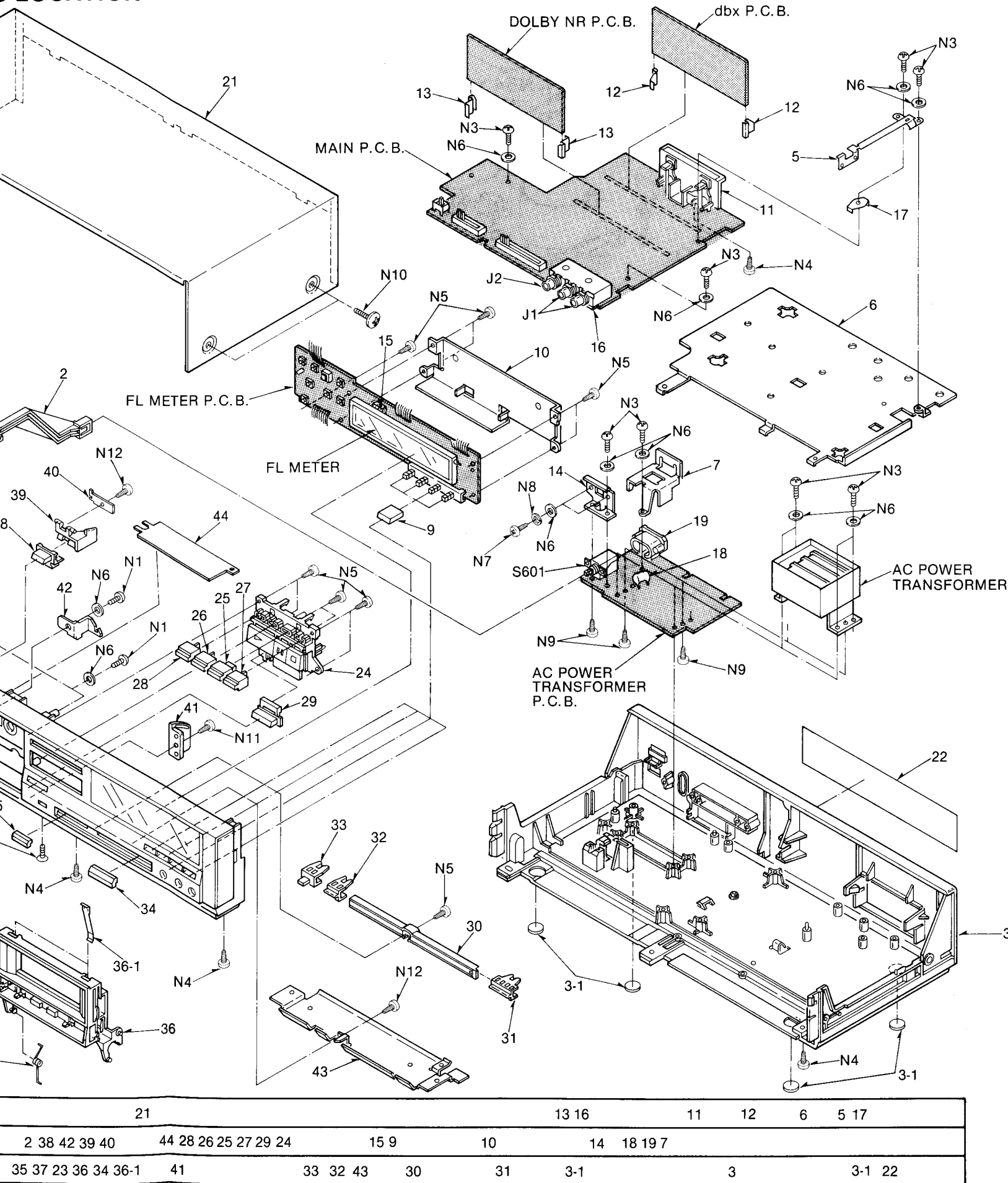

REPLACEMENT PARTS LIST

Important safety notice
Components identified by Δ mark have special characteristics important for safety.
When replacing any of these components, use only manufacturer's specified parts.

Areas

- * [M] For U.S.A.
- * [E] For all European areas except United Kingdom.
- * [EH] For Holland.
- * [EK] For United Kingdom.
- * [EGA] For F.R. Germany.
- * [XL] For Australia.
- * [XA] For Asia, Latin America, Middle East and Africa areas.

Ref. No.	Part No.	Part Name & Description	Ref. No.	Part No.	Part Name & Description	Ref. No.	Part No.	Part Name & Description
CABINET PARTS			23	SGYSB55-KE "Black Type"	Front Panel Assembly	SCREWS, NUTS & WASHERS		
1	SBC666	Power Button	23	SGYSB55-SE "Silver Type"	Front Panel Assembly	N 1	XTN3 + 10B	Tapping Screw φ3 × 10
2	SUB237	Power Rod	24	SGXS55-KE "Black Type"	Operation Chassis (B) Assembly	N 2	XTS3 + 10B	Tapping Screw φ3 × 10
3	[E][EH] [EGA] SKMSB25-SE	Main Case	24	SGXS55-SE "Silver Type"	Operation Chassis (B) Assembly	N 3	XTN3 + 12B	Tapping Screw φ3 × 12
3	[EK] [XA][XL] SKMSB25-SEK	Main Case	25	SBCSB25-SE	Record Button Assembly	N 4	XTB3 + 10BFZ	Tapping Screw φ3 × 10
3-1	SKL294	Case Foot	26	SBC732-3 "Black Type"	Fast Forward Button	N 5	XTB3 + 10BFN	Tapping Screw φ3 × 10
5	SUS795	Earth Plate	26	SBC732 "Silver Type"	Fast Forward Button	N 6	XWG3	Washer 3φ
6	SMC6377	Shield Plate	27	SBC732-1	Rec Mute Button	N 7	XSN3 + 6S	Screw φ3 × 6
7	SMN1965-1	Holder Angle	28	SBC732-4 "Black Type"	Rewind Button	N 8	XWA3B	Washer 3φ
8	QTD1315	Cord Clamper	28	SBC732-2 "Silver Type"	Rewind Button	N 9	XTV3 + 6JFZ	Tapping Screw φ3 × 6
9	SBC735-1 "Black Type"	Push Button	29	SBC734-1 "Black Type"	Reset Button	N 10	QH1324K	Ornament Screw
9	SBC735 "Silver Type"	Push Button	29	SBC734 "Silver Type"	Reset Button	N 10	QH1324 "Black Type"	Ornament Screw
10	SMN1968	Strengthen Angle (B)	30	SGX7756-1 "Black Type"	Slide Guide	N 11	XTB3 + 12BFN	Tapping Screw φ3 × 12
11	QJ5039C	Jack Board	30	SGX7756 "Silver Type"	Slide Guide	N 12	XSN26 + 8BN	Screw φ2.6 × 8
12	SMN1978	dbx P.C.B. Holder	31	SGX7757	Slider (A)	ACCESSORIES		
13	SME103-4	Dolby P.C.B. Holder	32	SGX7758	Slider (B)	A 1	[E][EH] [XA][XL] SQF12532	Instruction Book
14	SMN1974	Switch Angle	33	SBD121	Timer Knob	A 1	[EK] SQF12533	Instruction Book
15	SHG6372	Meter Holder Cushion	34	SBD122	Volume Knob (A)	A 1	[EGA] SQF12534	Instruction Book
16	SMN1970-1	Microphone Angle	35	SBD123	Volume Knob (B)	A 2	[E][EH] [EGA] SFDAC05E02	AC Power Cord
17	SNE55-1	Earth Terminal	36	SGXS25-SE1	Cassette Holder Assembly	A 2	[EK] SFDAC05G02	AC Power Cord
18	Δ SMX888	Spark Killer Cover	36-1	QBP2006A	Tape Pressure Spring	A 2	[XA] SJA168	AC Power Cord
19	[E] [EK][EH] [EGA] SJS9230	AC Inlet	37	SUS796	Holder Spring	A 2	[XL] SJA173	AC Power Cord
19	[XL] Δ SJS9235	AC Inlet	38	SBC736	Eject Button	A 3	QEB0125	Connection Cord
20	SGE1761-1 "Black Type"	Cassette Lid Assembly	39	SUB236	Eject Lever	A 4	[XA] Δ SJP9215	AC Plug Adaptor
20	SGE1761-3 "Silver Type"	Cassette Lid Assembly	40	SMN1971	Eject Spring	PACKINGS		
21	SKC1782K99-1 "Black Type"	Case Cover	41	QYF0627A	Damper Gear Assembly	P 1	[E][EH] [EGA] [XA][XL] SPG5352	Carton Box "Black Type"
21	SKC1782S98-1 "Silver Type"	Case Cover	42	SMN1966	Holder Angle	P 1	[E][EH] [EGA] [XA][XL] SPG5351	Carton Box "Silver Type"
22	[E][EH] [EGA] SGT36211	Main Name Plate	43	SMN1969	Connection Angle	P 1	[EK] SPG5354	Carton Box "Black Type"
22	[EK] SGT36241	Main Name Plate	44	SMC6386	Shield Sheet	P 1	[EK] SPG5353	Carton Box "Silver Type"
22	[XA] SGT36221	Main Name Plate						
22	[XL] SGT36231	Main Name Plate						

• Change of Part List (RS-955 from RS-B55)

Ref. No.	Change of Part No.		Description
	RS-B55[E] "Black Type"	RS-955[M]	
CABINET PARTS			
9	SBC735-1	SBC735	Push Button
18	Δ SMX88	—	Spark Killer Cover
20	SGE1761-1	SGE1761-2	Cassette Lid Assembly
22	SGT36211	SGT35951	Main Name Plate
ACCESSORIES			
A1	SQF12532	SQF12447	Instruction Book
A2	Δ SFDAC05E02	SJA170	AC Power Cord
PACKING			
P1	SPG5352	SPG5341	Carton Box

MECHANICAL PARTS LOCATION

• Front View

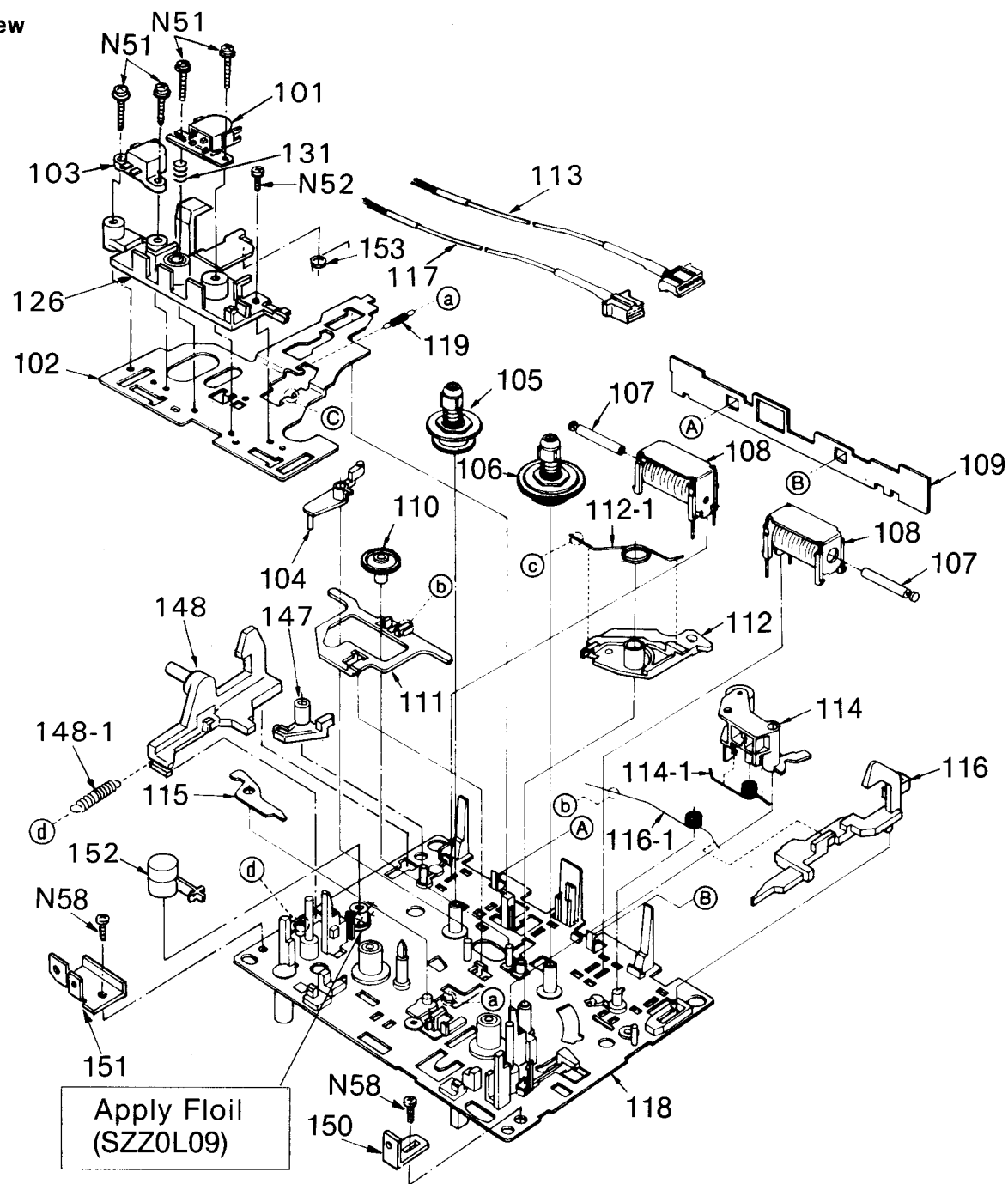

• Back View

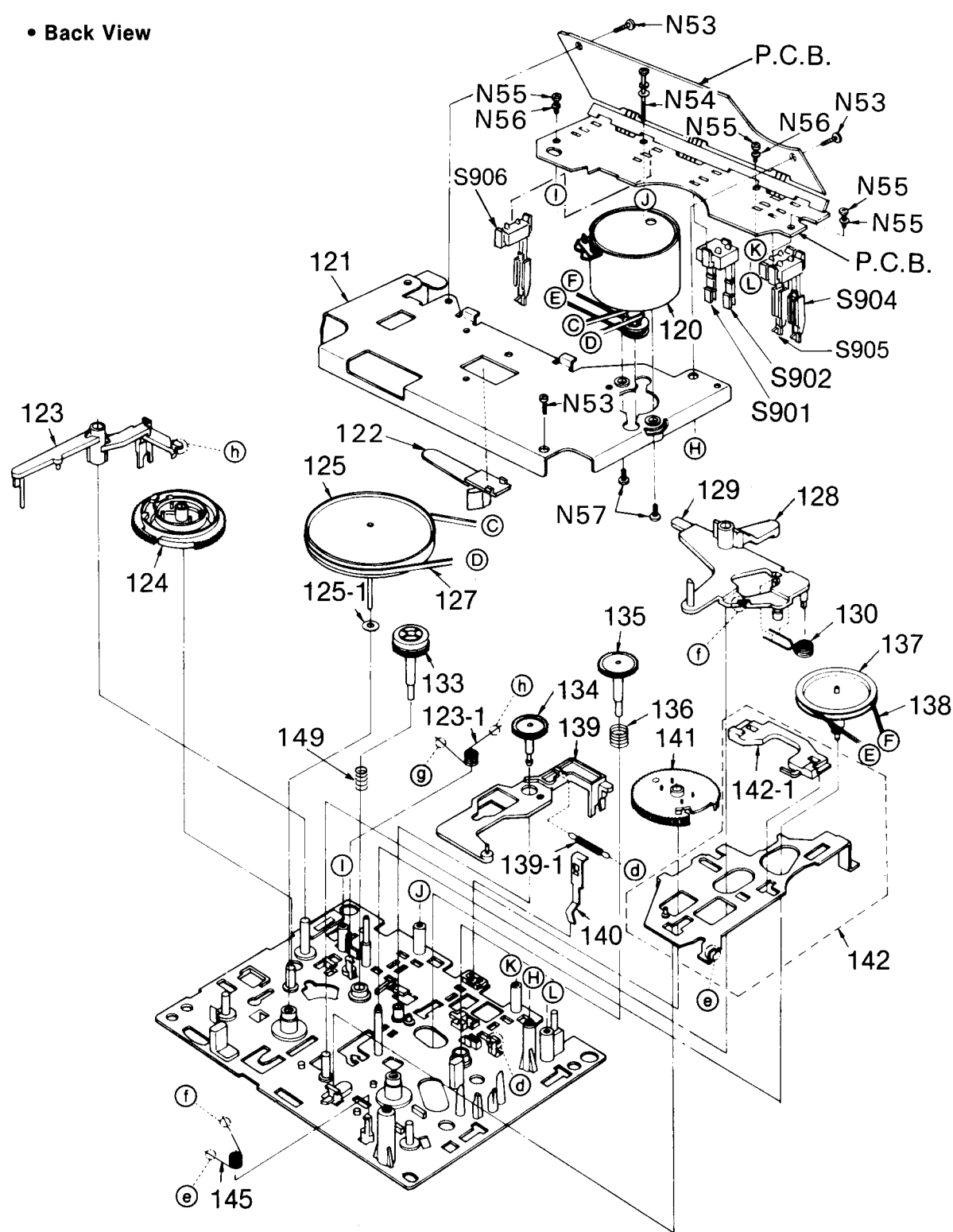

NOTES:

- When changing mechanism parts, apply the specified grease to the area marked "xx" shown in the drawing "Mechanical Parts Location".
- The grease and/or oil shown in the parentheses function to prevent friction (lubrication).

REPLACEMENT PARTS LIST

Ref. No.	Part No.	Part Name & Description	Ref. No.	Part No.	Part Name & Description	Ref. No.	Part No.	Part Name & Description	Ref. No.	Part No.	Part Name & Description	Ref. No.	Part No.	Part Name & Description
MECHANISM PARTS														
101	QWY4165G	Record/Playback Head	110	RDG5772Z	Take Up Relay Gear	119	RUD9Z	Head Base Plate Return Spring	128	RUB346Z	FF Arm	140	RUS609Z	Tape Pressure Spring
102	RUA9029Y	Head Base Plate	111	RUB353Z	Brake Rod	120	RJQG0001Z	DC Motor Ass'y	129	RUB348Z	FF Spring Lever	141	RDG5775Z	Sub. Gear
103	QWY2138G	Erase Head	112	RUBG0001Z	Main Lever Ass'y	121	RUL734Z	Flywheel, Bracket	130	RUW9Z	FF Arm Spring	142	RUBG0004Z	FF Rod Ass'y
104	RUB347Z	Take Up Change Arm	112-1	RUW14Z	Main Lever Spring	122	RMD5004Z	Spacer	131	SBC1278A	Spring	142-1	RUB345Z	FR Selecte Rod
105	RDMG0011Z	Supply Reel Table (F) Ass'y	113	RJSG0005Z	R/P Head Lead Wire	123	RUB350Z	Main Control Lever	133	RDGG0003Z	Reel Table Gear Ass'y	145	RUW8Z	FF Rod Spring
106	RDMG0001Z	Take Up Reel Table (R) Ass'y	114	RUBG0006Z	Pinch Roller (F) Ass'y	123-1	RUW10Z	Main Control Lever Spring	134	RDG5773Z	FF Relay Gear	SCREWS, NUTS & WASHERS		
107	RUB358Z	Shaft	114-1	RUW12Z	Pinch Roller Spring	124	RNG1Z	Main, Gear	135	RDG5789Z	Reel Table Gear	N 51	QHQ1361A	Screw ⊕2×8
108	RUEG0001Z	Plunger Ass'y	115	RUB343Z	Cue Lever	125	RDWG0003Z	Flywheel (F) Ass'y	136	RUQ10Z	Backtension Spring	N 53	XTN26+6B	Screw ⊕2.6×6
109	RUB344Z	Switch Lever	116	RNR2Z	Eject Rod	125-1	QBW2123	Washer (φ2.5)	137	RDRG0001Z	Main Pulley Ass'y	N 54	XYC2+FF15	Screw ⊕2×15
			116-1	RUW48Z	Eject Rod Spring	126	RMD5006Z	Head Speser	138	RDV27Z	FF, Belt (Square)	N 55	XTN2+5B	Screw ⊕2×5
			117	RJSG0006Z	E Head Lead Wire	127	RDV37Z	Main, Belt (Flat)	139	RUB349Z	Sub Control Lever	N 56	XWG2	Washer 2φ
			118	RUAG0001Z	Mecha Chassis				139-1	RUD8Z	Sub Control Lever Spring	N 57	XSN26+3	Screw ⊕2.6×3
												N 58	XTN4+6B	Screw ⊕4×6

• Back View

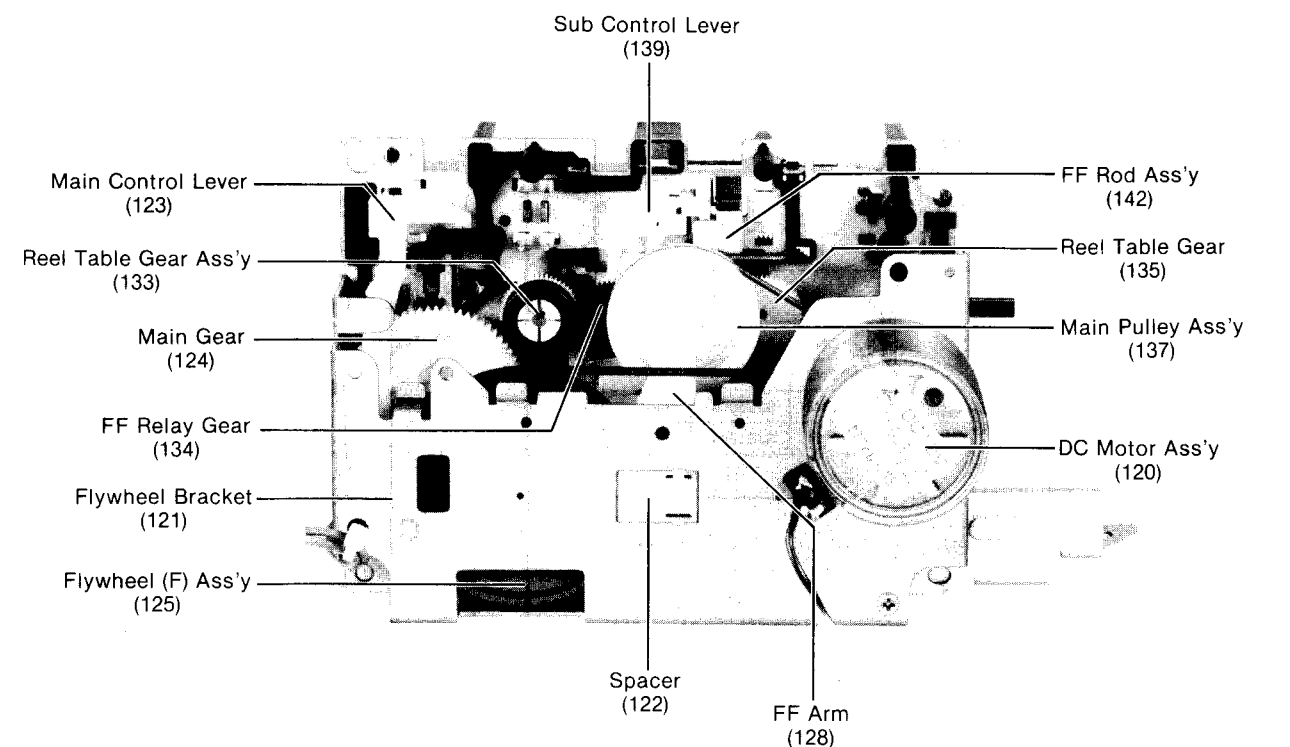
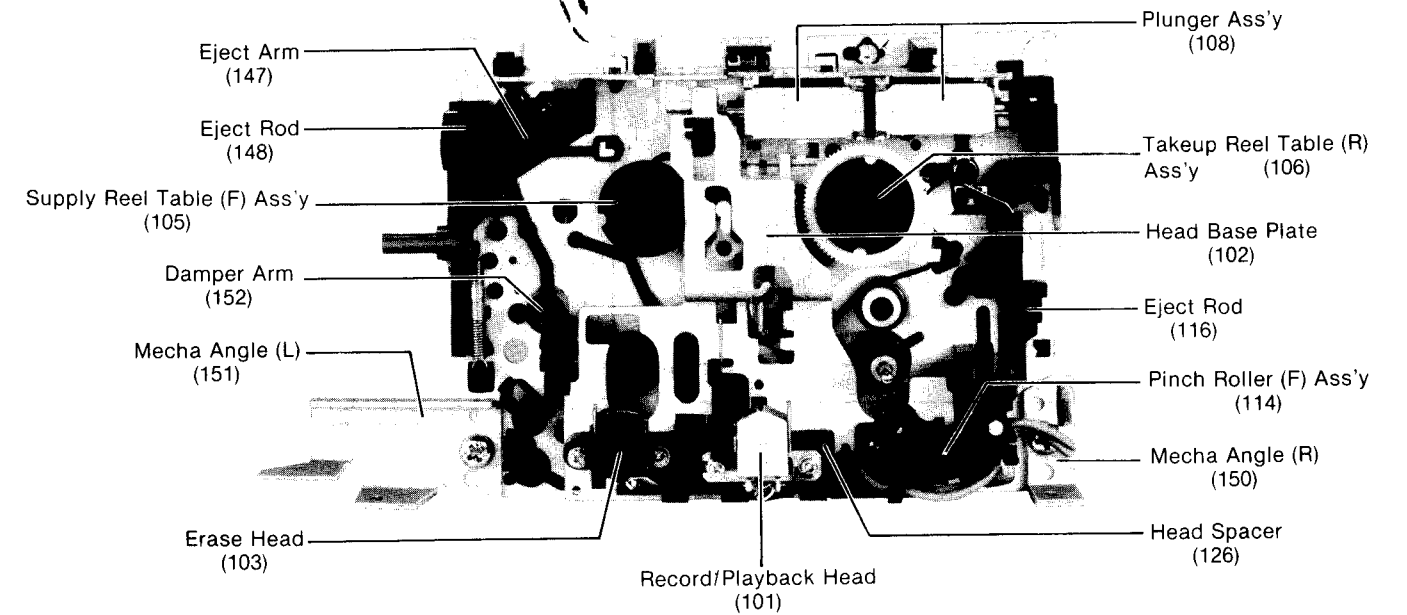
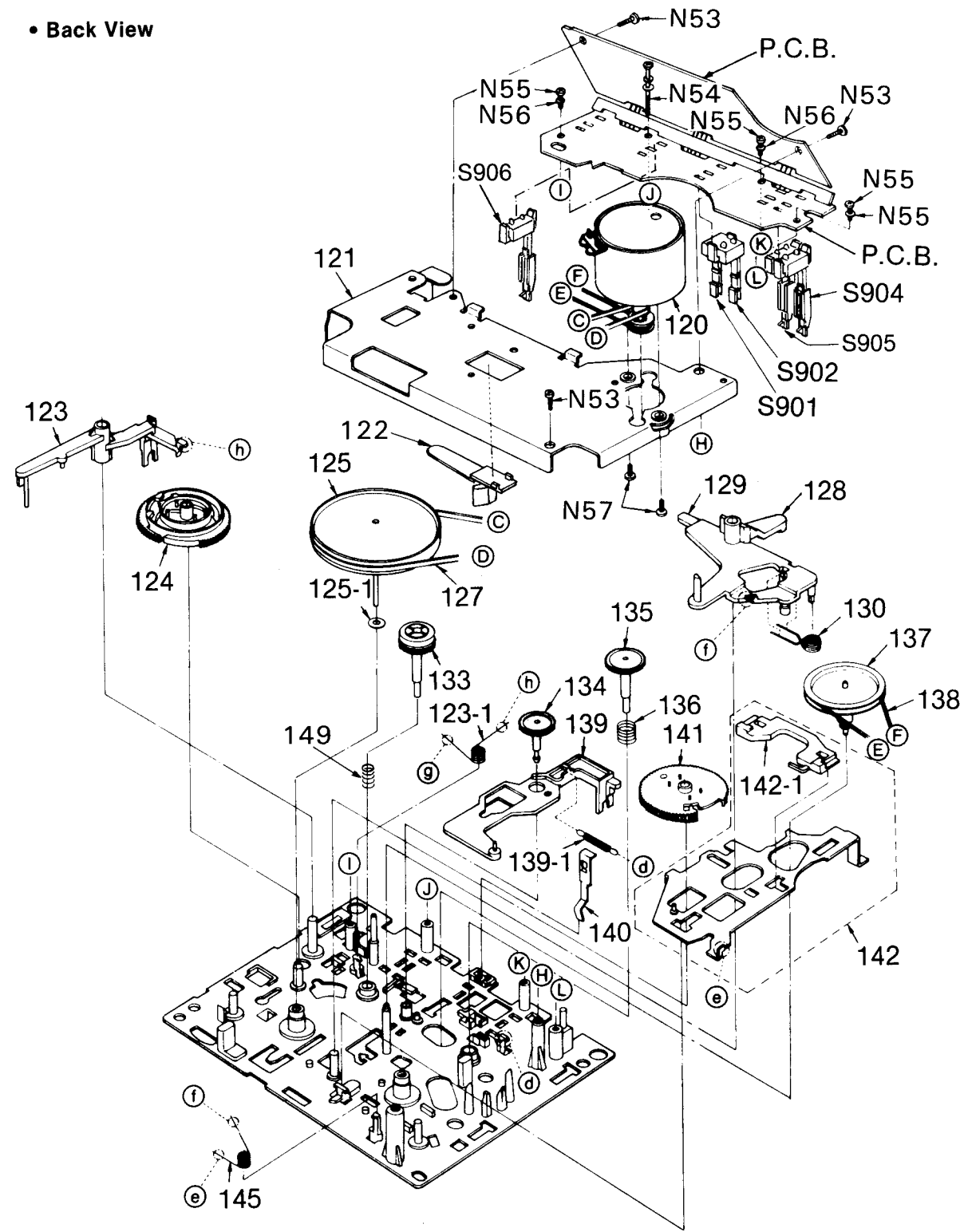

Part Name & Description	Ref. No.	Part No.	Part Name & Description	Ref. No.	Part No.	Part Name & Description	Ref. No.	Part No.	Part Name & Description
Head Base Plate Return Spring	128	RUB346Z	FF Arm	140	RUS609Z	Tape Pressure Spring	152	RNL1Z	Damper Arm
DC Motor Ass'y	120	RUB348Z	FF Spring Lever	141	RDG5775Z	Sub. Gear	153	RUW45Z	Takeup Arm Spring
Flywheel, Bracket	125	RUB348Z	FF Arm Spring	142	RUBG0004Z	FF Rod Ass'y	SCREWS, NUTS & WASHERS		
Spacer	122	SBC1278A	Spring	142-1	RUB345Z	FR Selecte Rod			
Main Control Lever	123	RDGG0003Z	Reel Table Gear Ass'y	145	RUW6Z	FF Rod Spring	N 51	QHQ1361A	Screw @2x8
Main Control Lever Spring	129	RDG5773Z	FF Relay Gear	147	RNL3ZA	Eject Arm	N 53	XTN26+6B	Screw @2.6x6
Main, Gear	124	RDG5769Z	Reel Table Gear	148-1	RNR1Z	Eject Rod	N 54	XYC2+FF15	Screw @2x15
Flywheel (F) Ass'y	125	RUQ10Z	Backtension Spring	149	RUD22Z	Eject Rod Spring	N 55	XTN2+5B	Screw @2x5
Washer (φ2.5)	145	RDRG0001Z	Main Pulley Ass'y	149	RUQ30ZA	Backtension Spring	N 56	XWG2	Washer 2φ
Head Speser	126	RDV27Z	FF, Belt (Square)	150	SMN1972	Mecha Angle (R)	N 57	XSN26+3	Screw @2.6x3
Main, Belt (Flat)	127	RUB349Z	Sub Control Lever	151	SMN1973	Mecha Angle (L)	N 58	XTN4+6B	Screw @4x6
		139-1	Sub Control Lever Spring						

MECHANICAL OPERATION (Description of mechanism operation)

STOP → PLAY OPERATION

- Employed for this unit is the newly developed mechanism. The conventional mechanism (RS-8R series) used two motors (for capstan drive and head up/down operation), while this newly developed mechanism uses only one motor for capstan and head up/down operation. The basic operations (STOP → PLAY) of this mechanism are explained in the following. (For the mechanism operation, refer to next page.)

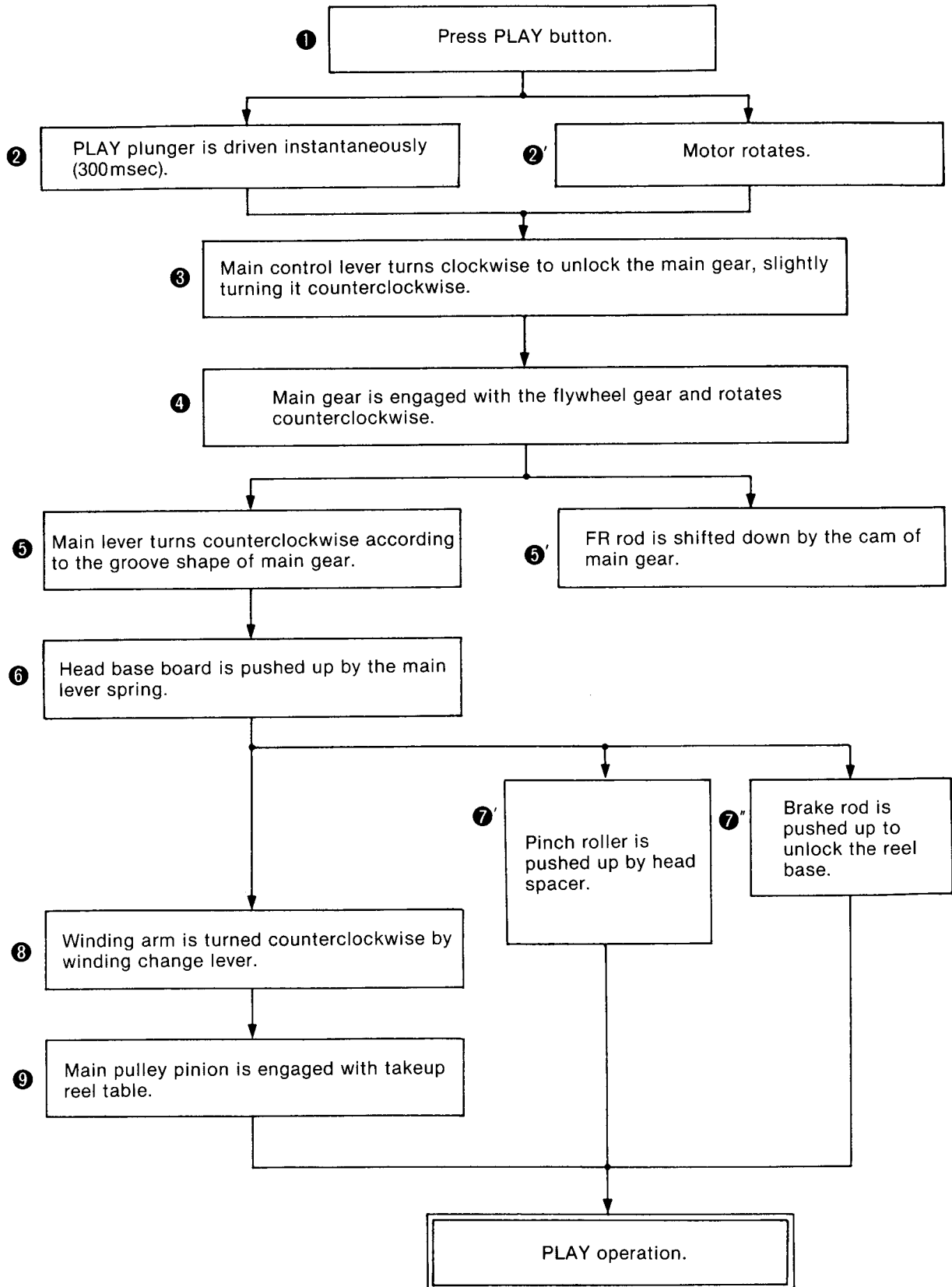

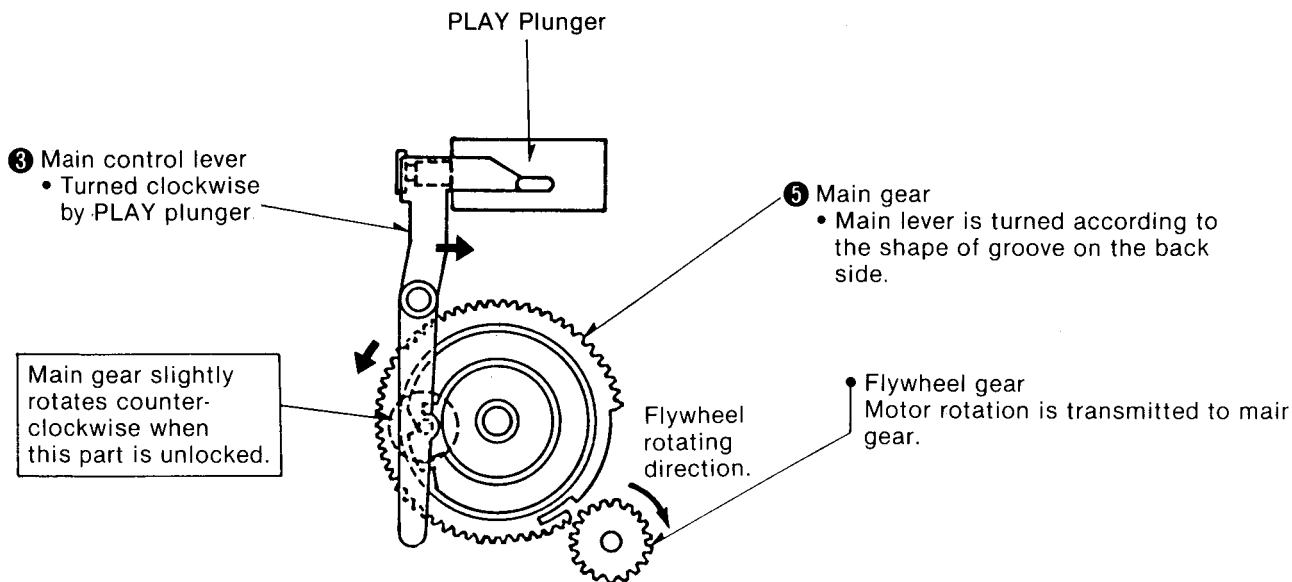

[Back view of mechanism in STOP mode.]

03160413 91004988
 SM-RSBS5
 SVC MNL (RS-955, USA) / DSM.
 08
 1 ST

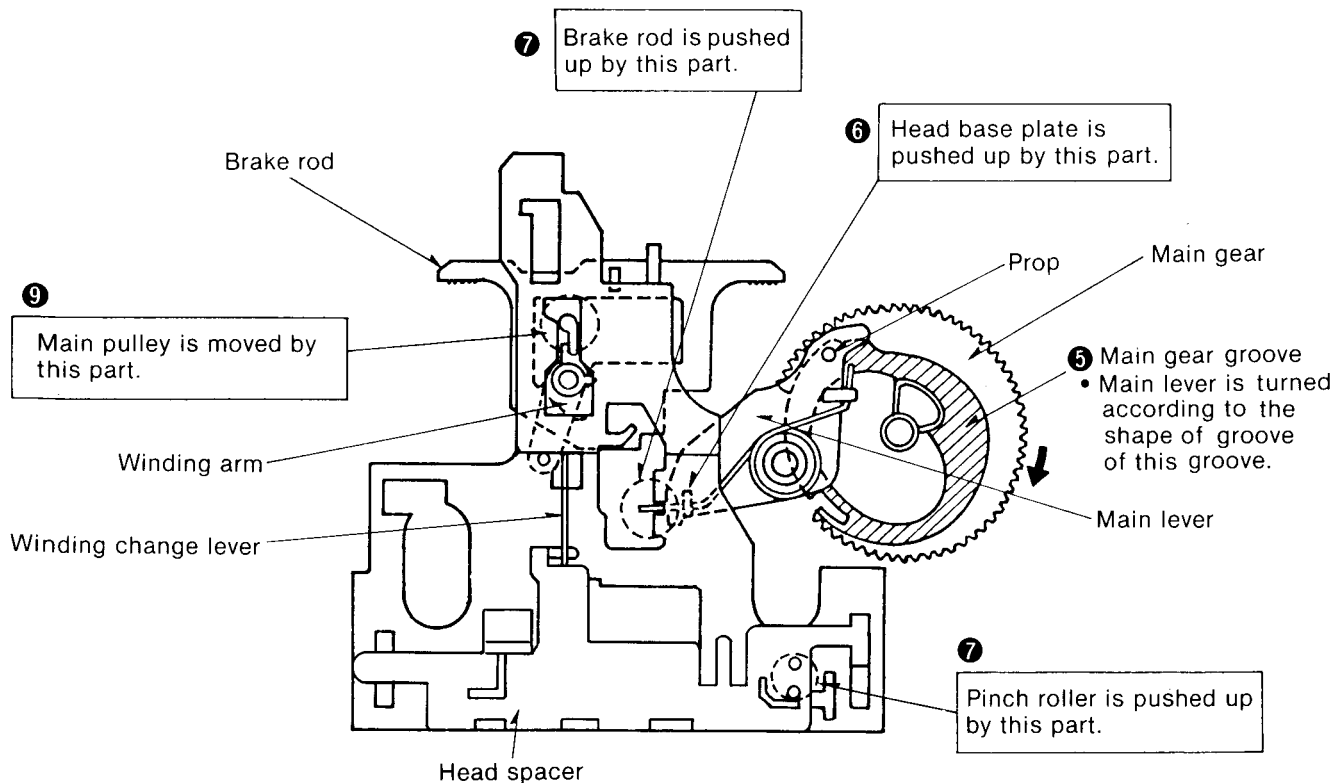

[Front view of mechanism in STOP mode.]

M E E K E H E G A X A X L