

# Service Manual

\*\* dbx/Closed Loop Dual Capstan  
DOUBLE DOLBY SYSTEM

Cassette Deck  
**RS-B905**

\*  DOLBY B-C NR HX PRO

Color

(K)...Black Type



Color	Areas
(K)	[M].....U.S.A.
(K)	[MC].....Canada.
(K)	[E].....All European areas except United Kingdom.
(K)	[EK].....United Kingdom.
(K)	[EG].....F.R. Germany.
(K)	[EH].....Holland.
(K)	[XA].....Asia, Latin America, Middle Near East, Africa and Oceania.
(K)	[XL].....Australia.
(K)	[XB].....Saudi Arabia.

## SPECIFICATIONS

Deck system	Stereo cassette deck
Track system	4-track, 2-channel
Heads	
REC/PLAY	Combination head
Erasing	Double-gap ferrite head
Motors	
Capstan	Electronically controlled DC motor
Reel table drive	Electronically controlled DC motor
Recording system	AC bias
Bias frequency	85 kHz
Erasing system	AC erase
Tape speed	4.8 cm/sec. (1-7/8 ips)
Frequency response	
METAL	20 Hz~22 kHz (±15 dB) 30 Hz~21 kHz (DIN)
CrO <sub>2</sub>	20 Hz~21 kHz (±15 dB) 30 Hz~20 kHz (DIN)
NORMAL	20 Hz~20 kHz (±15 dB) 30 Hz~19 kHz (DIN)
Dynamic Range (with dbx on)	110 dB (1 kHz)
Max. Input level improvement (with dbx on)	10 dB
S/N	(signal level = max recording level, CrO <sub>2</sub> type tape)
dbx on	92 dB (A weighted)
Dolby C NR on	75 dB (CCIR)
Dolby B NR on	67 dB (CCIR)
NR off	57 dB (A weighted)

Wow and flutter 0.04% (WRMS)  
±0.12% (DIN)

Fast Forward and Rewind Time  
Approx. 95 seconds with C-60 cassette tape

Input sensitivity and impedance  
LINE 60 mV/47 kΩ

Output voltage and impedance  
LINE 400 mV/2.2 kΩ  
HEADPHONES 125 mV/8 Ω

### ■ GENERAL

Power consumption 25W  
Power supply

For U.S.A. and Canada AC 60Hz, 120V

For continental Europe AC 50Hz/60Hz, 220V

For United Kingdom and other area  
AC 50Hz/60Hz, 110V/12V/220V/240V

Dimensions (W × H × D) 430 × 25 × 109.5mm  
(16-15/16" × 11-7/32" × 4-5/16")  
Weight 5 kg (11 lb.)

### Weight

\* HX Pro headroom extension originated by Barj Olufs en and manufactured under license from Dolby Laboratories Licensing Corporation.

"DOLBY", the double-D symbol, and "HX PRO" are trademarks of Dolby Laboratories Licensing Corporation.

\*\* The term dbx is a registered trademark of dbx Inc.

• Specifications are subject to change without notice.  
Weight and dimensions are approximate.

Matsushita Services Company  
50 Meadowland Parkway,  
Secaucus, New Jersey 07094

Panasonic Hawaii, Inc.  
91-238, Kauh St. Ewa Beach  
P.O. Box 774  
Honolulu, Hawaii 96808-0774

Matsushita Electric Trading Co., Ltd.  
P.O. Box 288, Central Osaka Japan

Panasonic Sales Company,  
Division of Matsushita Electric  
of Puerto Rico, Inc.  
Ave. 65 De Infanteria, KM 9.7  
Victoria Industrial Park  
Carolina, Puerto Rico 00630

Matsushita Electric  
of Canada Limited  
5770 Ambler Drive, Mississauga,  
Ontario, L4W 2T3

# Technics

## CONTENTS

	Page		Page
Safety Precaution .....	2	Wiring Connection Diagram .....	19
Accessories .....	2	Printed Circuit Boards .....	20~23
Location of Controls .....	3, 4	Block Diagram .....	24, 25
Technical Guides .....	4~7	Replacement Parts List .....	26, 27
Disassembly Instructions .....	7, 8	Cabinet Parts Location .....	28, 29
Measurement and Adjustment Methodes .....	9~12	Schematic Diagram .....	30~36
Microcomputer Terminal Function and Waveform .....	13~15	Replacement Parts List .....	37
Resistors & Capacitors .....	16~18	Mechanical Parts Location .....	38, 39
Terminal Guide of IC'S, Transistors and Diodes .....	18	Description of FL Panel .....	40

## SAFETY PRECAUTION (This "safety precaution" is applied only in U.S.A.)

1. Before servicing, unplug the power cord to prevent an electric shock.
2. When replacing parts, use only manufacturer's recommended components for safety.
3. Check the condition of the power cord. Replace if wear or damage is evident.
4. After servicing, be sure to restore the lead dress, insulation barriers, insulation papers, shields, etc.
5. Before returning the serviced equipment to the customer, be sure to make the following insulation resistance test to prevent the customer from being exposed to a shock hazard.

### INSULATION RESISTANCE TEST

1. Unplug the power cord and short the two prongs of the plug with a jumper wire.
2. Turn on the power switch.
3. Measure the resistance value with ohmmeter between the jumpered AC plug and each exposed metal cabinet part, such as screwheads antenna, control shafts, handle brackets, etc. Equipment with antenna terminals should read between  $3M\Omega$  and  $5.2M\Omega$  to all exposed parts. (Fig. A) Equipment without antenna terminals should read approximately infinity to all exposed parts. (Fig. B)

**Note:** Some exposed parts may be isolated from the chassis by design. These will read infinity.

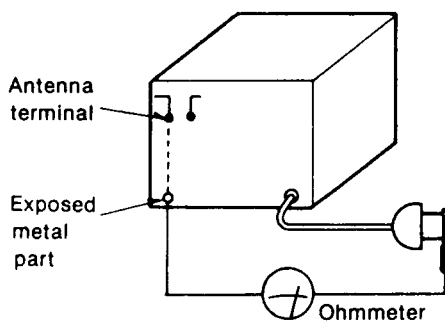

(Fig. A)

Resistance =  $3M\Omega - 5.2M\Omega$

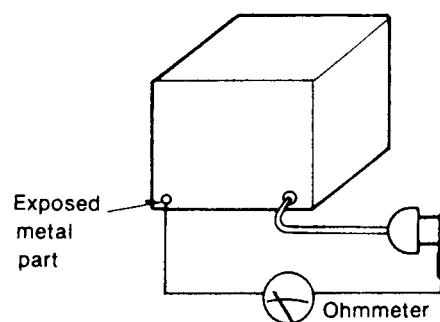

(Fig. B)

Resistance = Approx  $\infty$

4. If the measurement is outside the specified limits, there is a possibility of a shock hazard. The equipment should be repaired and rechecked before it is returned to the customer.

## ACCESSORIES

- AC power supply cord...1

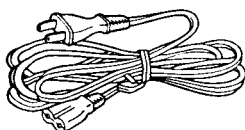

(SJA166—[M]  
SFDAC05E03—[E, EG, EH]  
SFDAC05G02—[EK]  
SJA173—[XL]  
SJA168—[XA]  
SJA183—[XB])

- AC plug adaptor...1 (SJP9215-[XA, XB])

- Stereo connection...2 (SJP2264)

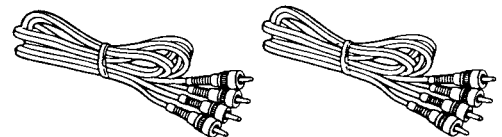

## LOCATION OF CONTROLS

### Front Panel

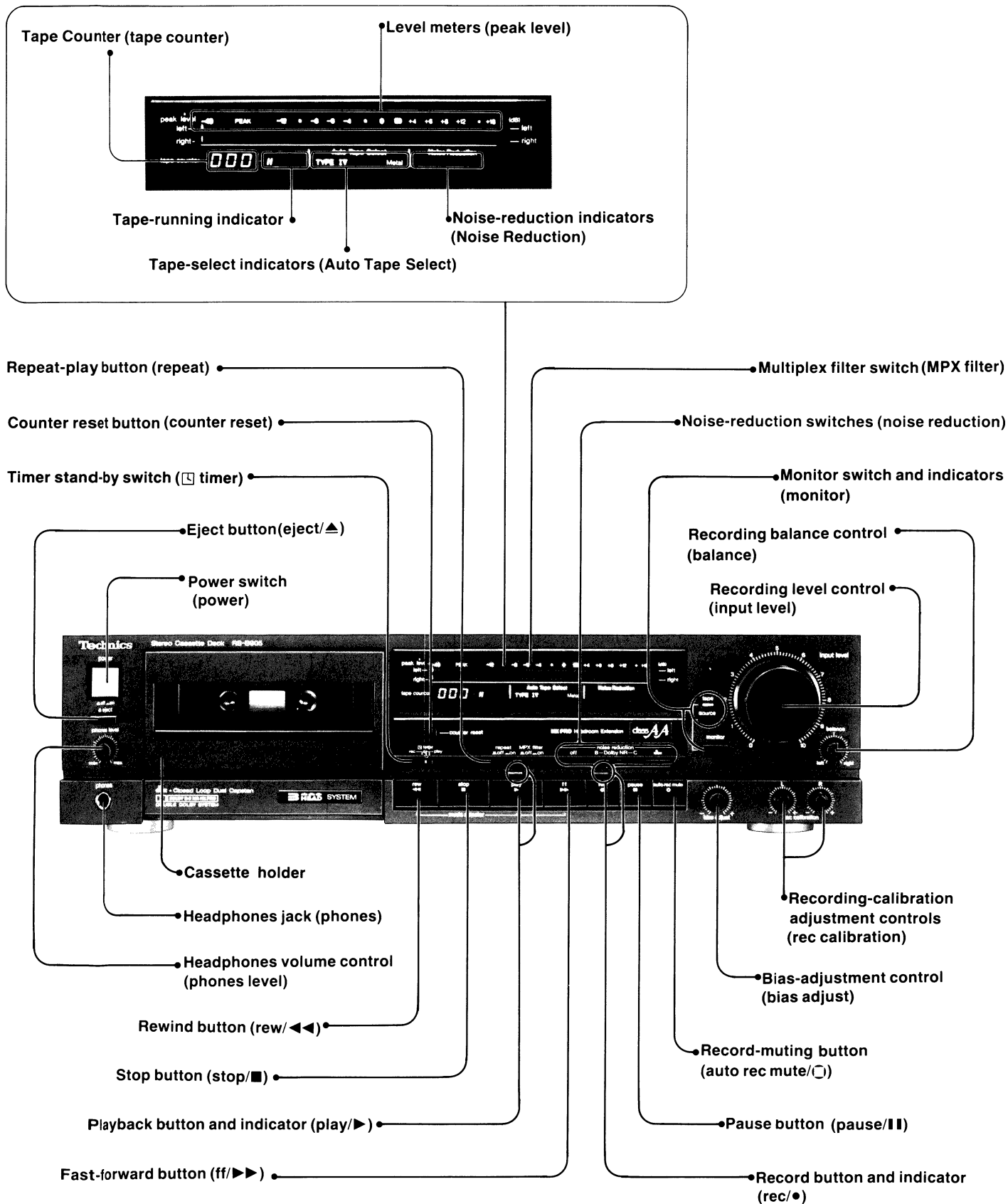

### Rear Panel

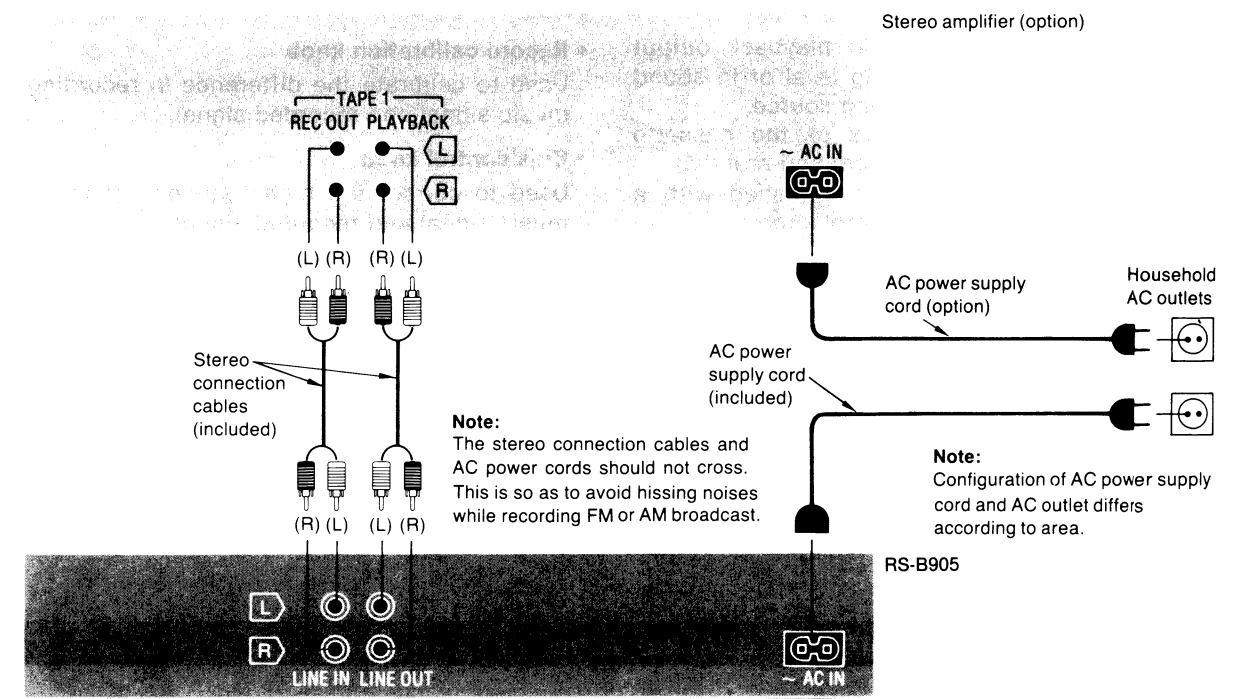

## TECHNICAL GUIDES

### Dolby HX Pro-Head Room Extension System

To record good quality sound, it is necessary to give bias current to the head. The bias current has characteristics as follows:

- Increasing the bias current reduces the distortion in low-frequency range but lowers the recording level in high-frequency range.
- Decreasing the bias current improves the recording level in high-frequency range but increases the distortion in low-frequency range.

In the case of a common deck, a specific level of bias current is determined according to the characteristics of recording head. Therefore, bias current cannot be applied to the head according to the frequency levels of music signal.

In order to solve such problems, this unit employs "Dolby HX-Pro". It picks up the high frequency of music source changing at all times, and controls the bias current level according to the changing frequency. It serves to make the bias current level then most suited for the music source.

This system always operates in recording mode irrespective of the noise reduction system, but the dynamic range in record/playback can be further increased by using this system in combination with a noise reduction system. Particularly, combination with the dbx NR system mounted in this unit will double the MOL (Maximum Output Level) in high frequency range, which is suited for the record/play-back of digital source as in CD.

### Dolby HX Pro System (NORMAL)

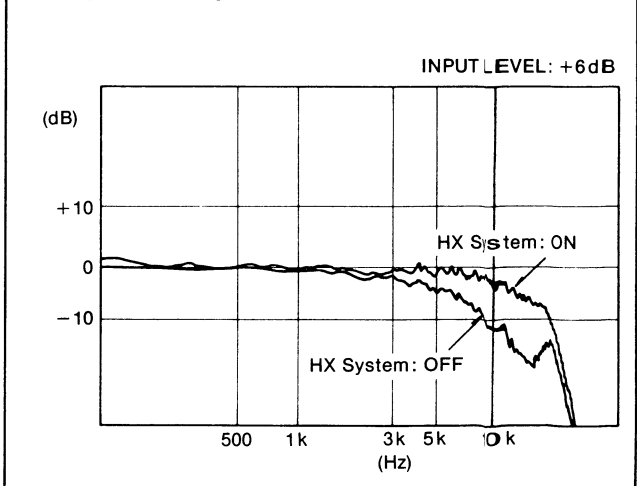

## Record Calibration/Bias Control Function

There are sometimes differences in playback output level even in case of same recording level or in sound quality even in case of same recording source.

This is because the characteristics of the cassette tape used are different with the makers and brands.

To solve this problem, this unit is furnished with a record calibration knob and bias control knob.

These knobs can be used to adjust the sound volume and quality while comparing the music signal (original sounds of record and tuner) and recorded signal (sound recorded on tape).

The comparison by hearing can be done by only one monitor switch because this unit is of 3-head type with record, playback and erase heads.

### • Record calibration knob

Used to calibrate the difference in recording level of music signal and recorded signal.

### • Bias control knob

Used to correct the high-frequency sound quality of music signal and recorded signal.

In this way, the record characteristics will not be distorted by tape, and the characteristics can be kept nearly uniform.

## < class AA > Circuit Recording Equalizer Amp

Recording equalizer amp is an amplifier to supply recording current to the head. Usually, loads such as recording head and bias trap circuit (bias current control circuit) are added to the amplifier. Therefore, the current phase and voltage phase are fluctuated causing the recording signal to be distorted. This unit employs "class AA" amp in which two types of amplifier circuits (voltage control amp and current supply amp) different in amplifying system. This recording equalizer amplifier is not influenced by the fluctuation of current phase or voltage phase as mentioned above, and is excellent in waveform response.

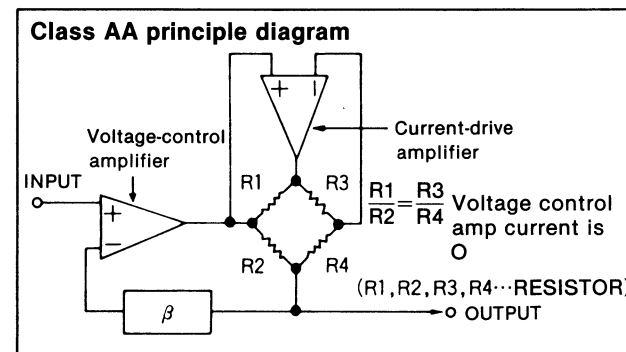

## Operation Principles of Noise Reduction System

### ● Dolby NR B type, C type

The level of hiss noise generated during playback is constant.

So, it is more offensive to the ear when the music signal level is lower.

Accordingly, raising the signal level during recording and lowering the level during playback will result in reduction of noise generated by the tape.

Dolby NR B type does it in high frequency range, and C type, in high and medium frequency ranges.

### ● dbx NR

Cassette tape is low in saturation level (limit of recording level). Therefore, distortion will be generated if music signal with large dynamic range (ratio of sound volumes of the weakest sound and the strongest sound) is recorded as it is.

dbx NR halves the music signal during recording and doubles it during playback.

In this way, dynamic range as large as 110dB and noise reduction effect as high as 30dB can be obtained, and good quality sound can be recorded even in case of music source with dynamic range as in CD and live performance.

## MPX Filter

If FM stereo broadcast is recorded by dolby NR, then the pilot signal included in the broadcast is also processed by dolby NR as music signal, causing deterioration of sound quality and worsening of noise reduction effect.

To solve this problem, this unit is furnished with MPX filter switch to cut off the pilot signal.

It serves to cut off the 19kHz single frequency of the pilot signal, which is different from a high cut filter installed in an amplifier, etc.

Also, MPX filter hardly causes change of sound quality in a sense of hearing.

(When recording a source other than FM broadcast, set this switch to off (■ → ■) position.)

### Pilot signal

This signal is used to separate FM broadcast into L (left) and R (right) channels, which is emitted at 19kHz very close to the music frequency band.

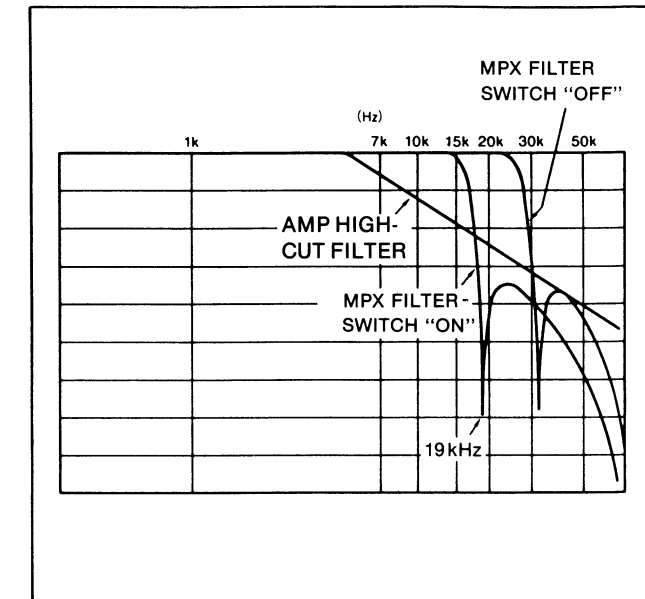

## Monitor Switch

In order to avoid faulty recording such as low sound level or distortion, it is very important to monitor the state of recording.

In the case of a common deck (2-head type), the sound that can be monitored during recording is always the sound before recording. So, when checking the state of actual recording, you have to rewind the tape and play it back.

This unit is of 3-head type, and the record head is independent of the playback head. Also, the sound before recording can be compared with the recorded sound by use of the monitor switch, therefore the state of recording can be easily checked.

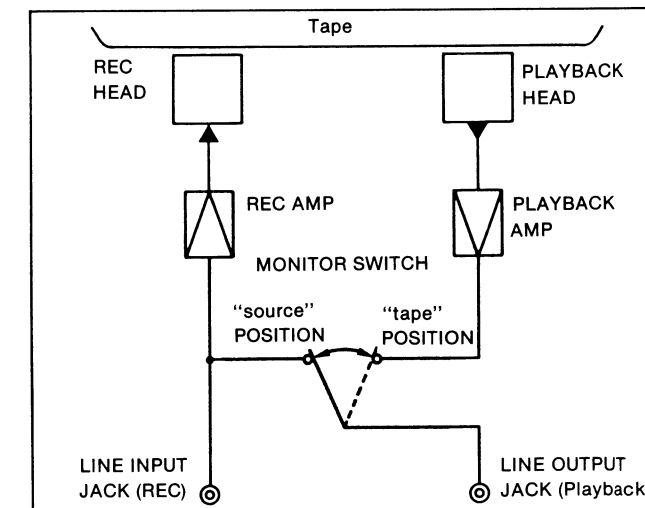

## Head care

To assure sound quality for recording and playback, be sure to clean the heads after approximately every 10 hours of use.

- 1) Press the power switch to switch off the electrical power supply of the cassette tape deck.
  - 2) Press the eject button to open the cassette holder.
  - 3) Clean the heads, pinch roller and the capstan shaft with a cotton swab (or with a soft, lint-free cloth) slightly moistened with alcohol.
- Do not use any solution other than alcohol for head cleaning.

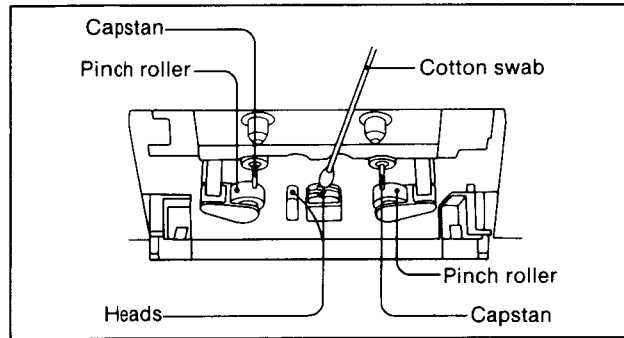

## Head demagnetization

In order to maintain good sound quality during recording and playback, it is recommended that the head assembly be demagnetized when distortion or poor sound quality persist after cleaning the heads.

If the head assembly becomes magnetized, it could create noise in the recordings, loss of high-frequency response or erasure of valuable recordings. Several types of head demagnetizers are available and may be purchased separately at local electronics supply stores. Follow the instructions that are supplied with the device.

- Do not bring any type of metal objects or tools such as magnetic screwdrivers in contact with the head assembly.

## Maintenance of external surfaces

To clean this unit, use a soft, dry cloth. If the surfaces are extremely dirty, use a soft cloth, dipped into a soap-and-water solution or a weak detergent solution. Wring the cloth well before wiping the unit. Wipe once again with a soft, dry cloth. Never use alcohol, paint thinner, benzene, nor a chemically treated cloth to clean this unit. Such chemicals may damage the finish of your unit.

## DISASSEMBLY INSTRUCTIONS

### "ATTENTION SERVICER"

Some chassis components may have sharp edges. Be careful when disassembling and servicing.

<b>Ref. No. 1</b>	<b>How to remove the cabinet</b>	<b>Ref. No. 3</b>	<b>How to remove the FL meter P.C.B.</b>
<b>Procedure 1</b>	• Remove the 5 screws.	<b>Procedure 1→3</b>	
<b>Ref. No. 2</b>	<b>How to remove the power P.C.B. and the main P.C.B.</b>		<ul style="list-style-type: none"> <li>• Remove the 4 screws (①~④), and then remove the angle.</li> <li>• Pull out the input level control knob and the balance control knob.</li> <li>• Remove the 2 screws (⑤, ⑥).</li> <li>• Push the 2 tabs.</li> </ul>
<b>Procedure 1→2</b>	<ul style="list-style-type: none"> <li>• Remove the connection rod.</li> <li>• Remove the 5 screws (⑥~⑩).</li> <li>• Remove the power P.C.B.</li> <li>• Remove the 5 screws (①~⑤).</li> <li>• Remove the main P.C.B.</li> </ul>		

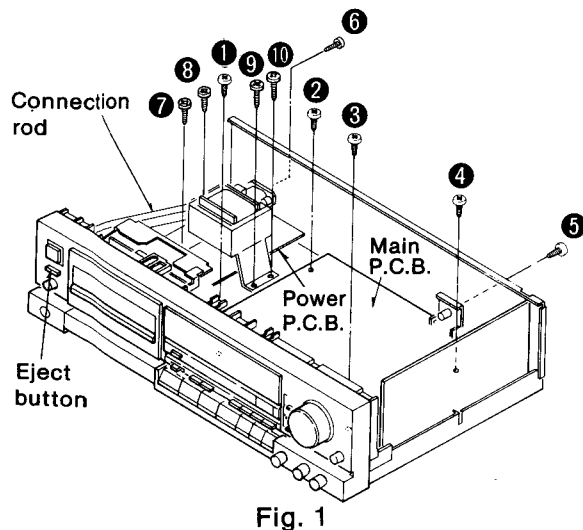

Fig. 1

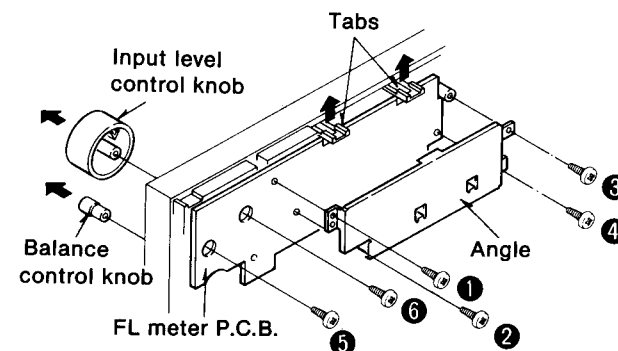

Fig. 2

<b>Ref. No. 4</b>	<b>How to remove the timer P.C.B. and the bias adjust/recording calibration control P.C.B.</b>	<b>Ref. No. 7</b>	<b>How to remove the operation switch P.C.B.</b>
<b>Procedure 1→2→3→4</b>	<ul style="list-style-type: none"> <li>• Remove the screw (③) and then the timer P.C.B.</li> <li>• Remove the 2 screws (①, ②).</li> <li>• Pull out the bias adjust knob.</li> <li>• Remove the bias adjust/recording calibration control P.C.B.</li> </ul>	<b>Procedure 1→7</b>	<ul style="list-style-type: none"> <li>• Remove the 5 screws (①~⑤)</li> </ul>

Bias adjust knob  
Timer P.C.B.  
Bias adjust/Recording calibration control P.C.B.

Headphones volume control knob  
Headphones P.C.B.  
Mechanism unit

- Remove the screw (⑦).
- Pull out the input level control knob and the balance control knob. (See the Fig. 2).
- Push the 3 tabs (⑧) and then remove the front panel.
- Push the 2 tabs (⑨).

Front Panel  
Operation SW P.C.B.  
Front Panel

Fig. 3

Fig. 5

<b>Ref. No. 5</b>	<b>How to remove the mechanism unit</b>		
<b>Procedure 1→5</b>	<ul style="list-style-type: none"> <li>• Remove the screw (⑥) (See the Fig. 5).</li> <li>• Remove the 5 screws (①~⑤).</li> <li>• Push the eject button.</li> </ul>		

Headphones volume control knob  
Headphones P.C.B.  
Mechanism unit

Fig. 4

<b>Ref. No. 6</b>	<b>How to remove the headphones P.C.B.</b>		
<b>Procedure 1→6</b>	<ul style="list-style-type: none"> <li>• Remove the 2 screws (⑥, ⑦). (See the Fig. 4).</li> <li>• Pull out the headphones volume control knob. (See the Fig. 4).</li> </ul>		

Fig. 6

## MEASUREMENT AND ADJUSTMENT METHODS

### Measurement Condition

- Input level controls; Maximum
- Timer start switch; Off
- Noise reduction select switch; Off
- Repeat-play switch; Off

### Measuring instrument

- EVM(Electronic Voltmeter)
- Oscilloscope
- Digital frequency counter
- AF oscillator

### Test tape

- Head azimuth adjustment (8kHz, -20dB); QZZCFM
- Tape speed adjustment (3kHz, -10dB); QZZCWAT
- Playback frequency response (315Hz, 12.5kHz, 10kHz, 8kHz, 4kHz, 1kHz, 250Hz, 125Hz, 63Hz, -20dB); QZZCFM

- Multiplex filter switch; Off
- Make sure heads are clean
- Make sure capstan and pressure roller are clean
- Judgeable room temperature  $20 \pm 5^\circ\text{C}$  ( $68 \pm 9^\circ\text{F}$ )

- ATT(Attenuator)
- DC voltmeter
- Resistor (600Ω)

- Playback gain adjustment (315Hz, 0dB); QZZCFM
- Overall frequency response, Overall gain adjustment
- Normal reference blank tape; QZZCRA
- CrO<sub>2</sub> reference blank tape; QZZCRX
- Metal reference blank tape; QZZCRZ

### HEAD AZIMUTH ADJUSTMENT

1. Playback the azimuth adjustment portion (8 kHz, -20 dB) of the test tape (QZZCFM). Vary the azimuth adjusting screw until the outputs of the L-CH and R-CH are maximized and the lissajous waveform, as illustrated, approaches 0 degrees.

**Note:** If L-CH and R-CH are not maximized at the same point, adjust to the point where the levels of each channel are maximized and equal.

2. Perform the same adjustment in the play mode.

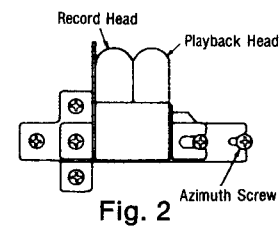
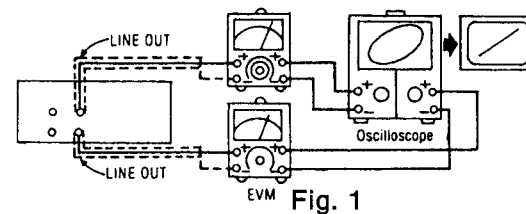

### TAPE SPEED ADJUSTMENT

1. Playback the middle portion of the test tape (QZZCWAT).  
2. Adjust the VR in the motor (see Fig. 3) so that the output is within the standard value.

Standard value:  $3000 \begin{matrix} +15 \\ -10 \end{matrix}$  Hz

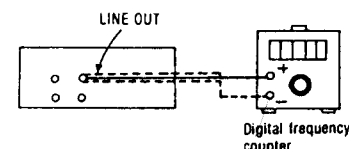

### PLAYBACK GAIN ADJUSTMENT

1. Playback the gain adjusted portion (315 Hz, 0 dB) of the test tape (QZZCFM).  
2. Adjust VR1 (L-CH) and VR2 (R-CH) so that the output is within the standard value.

Standard value:  $0.4V \pm 0.5dB$

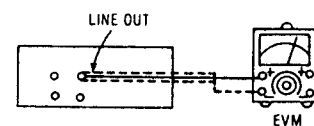

### PLAYBACK FREQUENCY RESPONSE

1. Playback the frequency response portion (315 Hz, 12.5 kHz ~ 63 Hz, -20 dB) of the test tape (QZZCFM).  
2. Assure that the frequency response is within the range shown in Fig. 6 for both L-CH and R-CH.

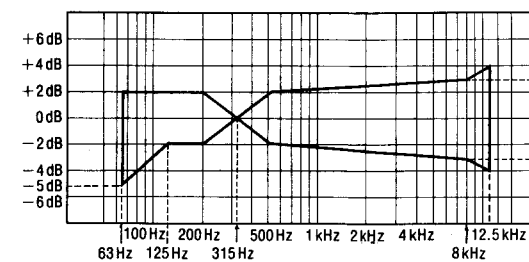
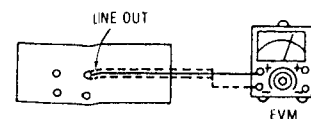

### FLUORESCENT METER ADJUSTMENT

1. Insert the Normal blank test tape (QZZCRA) and apply a reference input signal (1 kHz, -24 dB) in the Record Pause mode.  
2. Using an attenuator, adjust it until the voltage of the tape decks "LINE OUT" terminals is 0.4V.

#### -40 dB ADJUSTMENT

3. Attenuate the signal input level in step 1, by 40 dB and apply it to the unit.  
4. Adjust VR61 so that the "-40 dB" segment is slightly illuminated.

#### -0 dB ADJUSTMENT

5. Set the input signal level as indicated in step 2 above.  
6. Adjust VR62 so that the "0 dB" segment is slightly illuminated.  
7. Repeat steps 1 ~ 6 above and assure that both the -40 dB and 0 dB segments illuminate slightly.

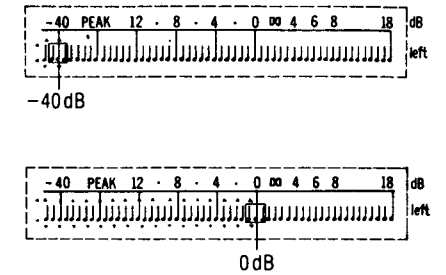

Fig. 7

### OVERALL FREQUENCY RESPONSE

1. Insert the Normal blank test tape (QZZCRA) and set the unit to the Record Pause mode.  
2. Apply a reference input signal (1 kHz, -24 dB) through an attenuator.  
3. Attenuate the signal by 20 dB and adjust the frequency from 50 Hz ~ 15 kHz.  
4. Record the frequency sweep.  
5. Playback the recorded signal and assure that it is within the range shown in Fig. 9 in comparison to the reference frequency (1 kHz).  
6. If it is not within the standard range, adjust VR301 (L-CH) and VR302 (R-CH) so that the frequency level is within the standard range.  
● Level up in high frequency range.....Increase the bias current.  
● Level down in high frequency range...Decrease the bias current.  
7. Repeat steps 2 ~ 6 above using the CrO<sub>2</sub> tape(QZZCRX) and the Metal tape(QZZCRZ) increasing the frequency range to 16 kHz (50Hz~16kHz).  
8. Assure that the level is within the range shown in Fig. 10.

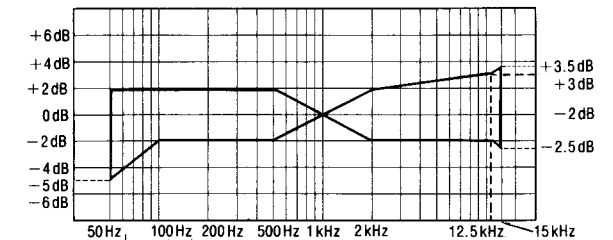

Fig. 9

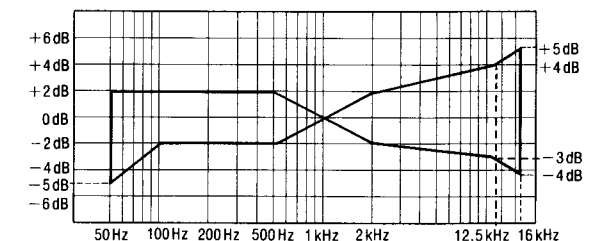
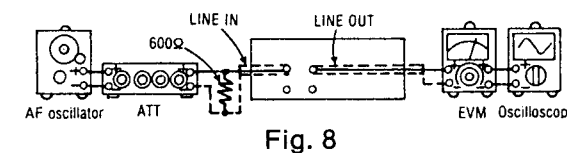

Fig. 10



### OVERALL GAIN ADJUSTMENT

1. Insert the Normal blank test tape (QZZCRA) and set the unit to the Record pause mode.  
2. Apply a reference input signal (1 kHz, -24 dB). Attenuate the output so that its level becomes 0.4V.  
3. Record this input signal.  
4. Playback the signal recorded in step 3 above, and assure that the output is within the standard value.  
5. If it is not within the standard value, adjust VR151 (L-CH) and VR152 (R-CH).  
6. Repeat the step 2 ~ 5 above until the output is within the standard value.

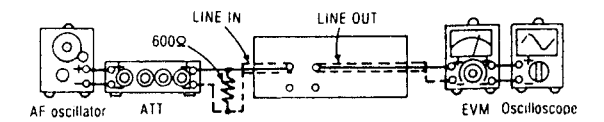

Fig. 11

Standard value:  $0.4V \pm 0.5dB$

### HX-PRO ADJUSTMENT

1. Insert the Metal blank tape (QZZCRZ) and set the unit to the Record Pause mode.
2. Connect a DC voltmeter across R325 (L-CH., 10 ohms) and R326 (R-CH., 10 ohms).
3. Adjust L303 (L-CH) and L304 (R-CH) so that the voltage becomes less than 110mV DC.

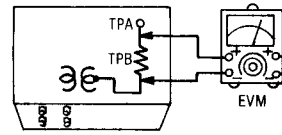
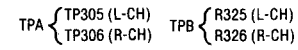

Fig. 12



### dbx TIMING ADJUSTMENT

#### ENCODE SIDE

1. Set the noise reduction switch to the dbx position.
2. Apply a 1 kHz signal to LINE IN terminals through an attenuator.
3. Connect an AC voltmeter across R565 (L-CH) and R566 (R-CH). Adjust the input signal level so that the voltage is 20 mV.
4. Connect a DC voltmeter across R550 (TP551) and adjust VR551, so that the voltage becomes 15 mV.

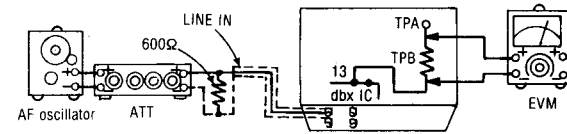
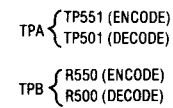

Fig. 13



#### DECODE SIDE

5. Repeat steps 1 and 2 above.
6. Connect an AC voltmeter across R515 (L-CH) and R516 (R-CH). Adjust the input signal level so that the voltage is 20 mV.
7. Connect a DC voltmeter across R500 (TP501) and adjust VR501 so that the voltage becomes 15 mV.

### dbx GAIN ADJUSTMENT

1. Insert the Normal blank test tape (QZZCRA) and set the unit to the Record mode.
2. Apply a 1 kHz signal to the "LINE IN" through an attenuator.
3. Adjust the input level so that the meter reading is 0 dB.
4. Connect an AC voltmeter to the "LINE OUT" terminal.
5. Switch the Monitor switch position between "TAPE" and "SOURCE". Adjust VR553 (L-CH) and VR554 (R-CH) so that the voltage difference at "LINE OUT" is within 0.5 dB.

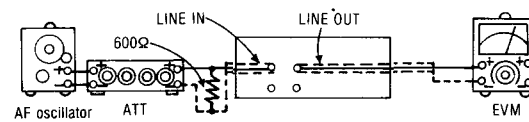
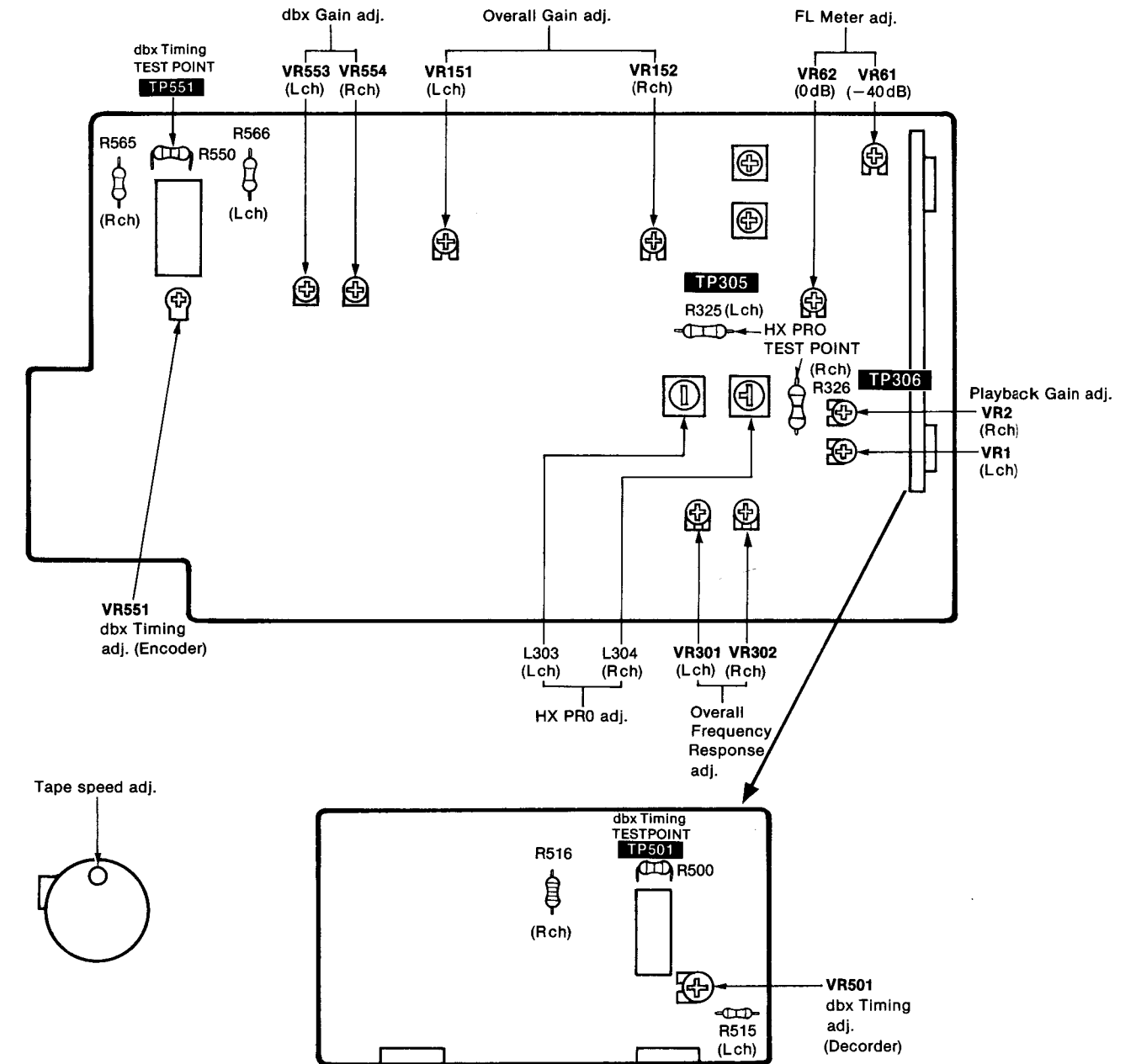
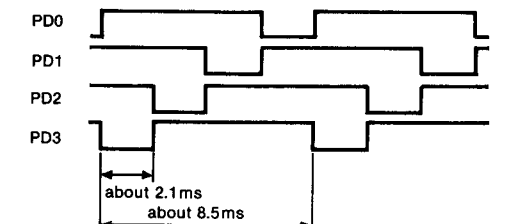
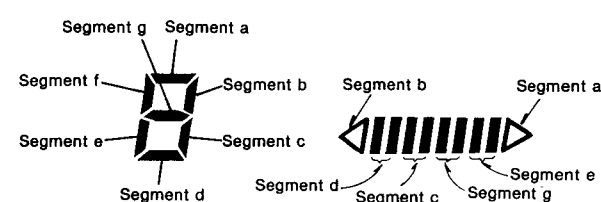



Fig. 14

### • Adjust ment point



## ■ MICROCOMPUTER TERMINAL FUNCTION AND WAVEFORM (IC901: LM6495G-2104)

Terminal No.	Symbol	Function/operation																									
1, 42	XTAL	about 800kHz																									
2	PC0	Scan input <table border="1" style="margin-left: 20px;"> <caption>Key scan matrix</caption> <tr> <td></td> <td>PD0</td> <td>PD1</td> <td>PD2</td> <td>PD3</td> </tr> <tr> <td>PC0</td> <td>auto rec mute</td> <td>rew</td> <td>Timer play</td> <td>REC INH SW</td> </tr> <tr> <td>PC1</td> <td>pause</td> <td>ff</td> <td>Timer rec</td> <td>PACK SW</td> </tr> <tr> <td>PC2</td> <td>rec</td> <td>—</td> <td>monitor sw</td> <td>—</td> </tr> <tr> <td>PC3</td> <td>stop</td> <td>play</td> <td>Counter Reset sw</td> <td>—</td> </tr> </table>		PD0	PD1	PD2	PD3	PC0	auto rec mute	rew	Timer play	REC INH SW	PC1	pause	ff	Timer rec	PACK SW	PC2	rec	—	monitor sw	—	PC3	stop	play	Counter Reset sw	—
	PD0		PD1	PD2	PD3																						
PC0	auto rec mute		rew	Timer play	REC INH SW																						
PC1	pause		ff	Timer rec	PACK SW																						
PC2	rec		—	monitor sw	—																						
PC3	stop	play	Counter Reset sw	—																							
3	PC1																										
4	PC2																										
5	PC3																										
6	$\overline{\text{INT}}$	Connection of GND																									
7	RES	Reset the microcomputer when power switch is thrown in. Reset at "L".																									
8	PD0	Scan output 																									
9	PD1																										
10	PD2																										
11	PD3																										
12	PE0	Connection of GND																									
13	PE1	<ul style="list-style-type: none"> <li>Segment a (PE 1)</li> <li>Segment b (PE 2)</li> <li>Segment c (PE 3)</li> <li>Segment d (PF 0)</li> <li>Segment e (PF 1)</li> <li>Segment f (PF 2)</li> <li>Segment g (PF 3)</li> </ul>  <p>• According to the internal command of IC, the counter number changes with 2 turns of the take-up reel. Also, the running display changes by 1 with 1/2 turn.</p> <p>• Each waveform changes because of dynamic lighting.</p>																									
14	PE2																										
15	PE3																										
16	PF0																										
17	PF1																										
18	PF2																										
19	PF3																										
20	TEST	Connection of GND																									
21	VSS																										
22	PG0	Input of Repeat switch ON... "H" OFF... "L"																									
23	PG1	"L" when REC/REC PAUSE mode switch is on mode. "L" when Timer REC mode is power on in about 1.25sec.																									
24	PG2	"L" when REC switch is on mode.																									
25	PG3	<ul style="list-style-type: none"> <li>"L" when PLAY switch is on mode.</li> <li>MUSIC SELECTOR mode</li> <li>PAUSE mode</li> </ul> 																									

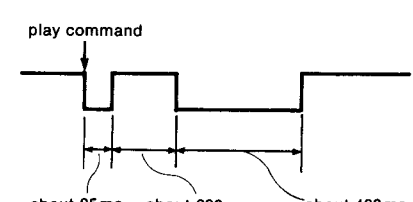
Terminal No.	Symbol	Function/operation																																																								
26	PH0	"L" when TAPE of MONITOR SELECTOR and POWER switch is on mode. "L" when PLAY from STOP, PAUSE, FF, REW and MS is moving. (auto monitor select)																																																								
27	PH1	"L" when SOURCE of MONITOR SELECT is ON mode. "L" when REC PAUSE mode from STOP and PAUSE ect is moving.																																																								
28	MSP	MUSIC SELECTOR, NON RECORDED SPACE pulse input Record... "L" Non-record... "H"																																																								
29	PH3	Source mode... "L" Tape mode... "H" FF/REW/MS... "L"																																																								
30	PI0	<ul style="list-style-type: none"> <li>Meter mute output... "L" (P10)</li> <li>Lineout mute output... "H" (P11)</li> <li>REC Amp mute output... "L" (P12)</li> </ul>																																																								
31	PI1																																																									
32	PI2																																																									
		<table border="1" style="margin-left: 20px;"> <thead> <tr> <th colspan="2" rowspan="2"></th> <th rowspan="2">Stop Pause ff/rew</th> <th rowspan="2">play</th> <th colspan="2">Rec pause</th> <th colspan="2">Rec play</th> </tr> <tr> <th>Normal</th> <th>A.R.M.</th> <th>Normal</th> <th>Auto Rec Mute</th> </tr> </thead> <tbody> <tr> <td rowspan="3">TAPE mode</td> <td>PI0</td> <td>L</td> <td>H</td> <td>L</td> <td>L</td> <td>H</td> <td>L</td> </tr> <tr> <td>PI1</td> <td>H</td> <td>L</td> <td>H</td> <td>H</td> <td>L</td> <td>L</td> </tr> <tr> <td>PI2</td> <td>L</td> <td>L</td> <td>L</td> <td>L</td> <td>H</td> <td>L</td> </tr> <tr> <td rowspan="3">SOURCE mode</td> <td>PI0</td> <td>H</td> <td>H</td> <td>H</td> <td>L</td> <td>H</td> <td>L</td> </tr> <tr> <td>PI1</td> <td>L</td> <td>L</td> <td>L</td> <td>L</td> <td>L</td> <td>L</td> </tr> <tr> <td>PI2</td> <td>L</td> <td>L</td> <td>L</td> <td>L</td> <td>H</td> <td>L</td> </tr> </tbody> </table> <p style="margin-left: 20px;">PI0, PI2 { "H" = Muting OFF "L" = Muting ON } PI1 { "H" = Muting ON "L" = Muting OFF }</p>			Stop Pause ff/rew	play	Rec pause		Rec play		Normal	A.R.M.	Normal	Auto Rec Mute	TAPE mode	PI0	L	H	L	L	H	L	PI1	H	L	H	H	L	L	PI2	L	L	L	L	H	L	SOURCE mode	PI0	H	H	H	L	H	L	PI1	L	L	L	L	L	L	PI2	L	L	L	L	H	L
		Stop Pause ff/rew					play	Rec pause		Rec play																																																
			Normal	A.R.M.	Normal	Auto Rec Mute																																																				
TAPE mode	PI0	L	H	L	L	H	L																																																			
	PI1	H	L	H	H	L	L																																																			
	PI2	L	L	L	L	H	L																																																			
SOURCE mode	PI0	H	H	H	L	H	L																																																			
	PI1	L	L	L	L	L	L																																																			
	PI2	L	L	L	L	H	L																																																			
33	PA0	FF/REW motor speed control PLAY mode... "L"																																																								
34	PA1	FF/REW motor drive REW mode... "H"																																																								
35	PA2	FF/REW motor drive FF mode... "H"																																																								
36	PA3	Capstan motor drive STOP/PAUSE/FF/REW/MS mode... "H" PLAY mode... "L"																																																								
37	PB0	Plunger drive During music select mode, plunger attraction is maintained to keep Cue/Review mode.																																																								
38	PB1	<ul style="list-style-type: none"> <li>Plunger drive</li> <li>Mechanism mode selector control output</li> <li>STOP...PLAY</li> </ul> 																																																								

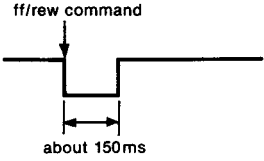
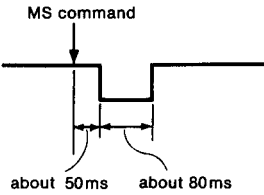
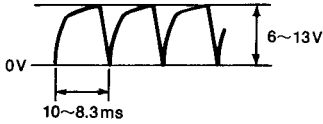

Terminal No.	Symbol	Function/operation
38	PB1	<p>• STOP...FF/REW</p>  <p>• PLAY...MS</p> 
39	PB2	<p>• Reel base pulse Reel base rotation is detected by photo sensor. Pulses are used for tape-end detection and counter up/down.</p>
40	POF	<p>Power of DET</p> 
41	$V_{DD}$	Operative on about 5V

# RESISTORS & CAPACITORS

## Notes: \* Important safety notice:

Components identified by  $\Delta$  mark have special characteristics important for safety. When replacing any of these components use only manufacturer's specified parts.

\* Bracketed indications in Ref. No. columns specify the area.

Parts without these indications can be used for all areas.

## Numbering System of Resistor

### Example

ERD	25	F	J	102
Type	Wattage	Shape	Tolerance	Value
ERX	2	AN	J	471
Type	Wattage	Shape	Tolerance	Value
				$47 \times 10^1$ (ohm)

## Numbering System of Capacitor

### Example

ECKD	1H	102	Z	F
Type	Voltage	Value	Tolerance	Peculiarity
ECEA	50	M		330
Type	Voltage	Peculiarity		Value
				$(33 \times 10^0$ microfarad)

Resistor Type	Wattage	Tolerance
ERD : Carbon	10 : 1/8W	J : $\pm 5\%$
ERG : Metal Oxide	12 : 1/2W	F : $\pm 1\%$
ERX : Metal Film	25 : 1/4W	G : $\pm 2\%$
ERQ : Fuse Type Metal	1A : 1W	K : $\pm 10\%$
ERD [ ] L : Carbon (chip)	18 : 1/8W	
ERD [ ] K : Metal Film (chip)	S2 : 1/4W	
ERC : Solid	S1 : 1/2W	
	2F : 1/4W	
	50 : 1/2W	
	2A : 2W	

Capacitor Type	Voltage	Tolerance
ECE : Electrolytic	0J : 6.3V	C : $\pm 0.25\text{pF}$
ECCD : Ceramic	1A : 10V	J : $\pm 5\%$
ECKD : Ceramic	1C : 16V	K : $\pm 10\%$
ECQM : Polyester	1E : 25V	Z : $+80\%$
	1H : 50V	-20%
ECQP : Polypropylene	1V : 35V	P : $+100\%$
	50 : 50V	-0%
ECCG : Ceramic	05 : 50V	M : $\pm 20\%$
ECEA [ ] [ ] N : Non Polar Electrolytic	2H : 500V	
	2A : 100V	D : $\pm 0.5\text{pF}$
QCU [ ] : Ceramic (Chip Type)	1 : 100V	G : $\pm 2\%$
ECUX : Ceramic (Chip Type)	KC : 400V AC	
ECF : Semiconductor	KC : 125VAC (UL)	
	1J : 63V	
EECW : Liquid electrolyte double layer capacitor		

Ref. No.	Part No.	Part Code	Ref. No.	Part No.	Part Code	Ref. No.	Part No.	Part Code
<b>RESISTORS</b>			R75, R76	ERD25FJ122	001 152 0226 9	R221	ERD25FJ331	001 152 0286 7
			R80	ERDS2TJ104	001 152 2348 2	R222, R223	ERDS2TJ103	001 152 2347 3
R1, R2	ERDS2TJ683	001 152 2450 5	R101, R102	ERDS2TJ333	001 152 2358 0	R224, R225	ERDS2TJ103	001 152 2347 3
R3, R4	ERDS2TJ101	001 152 2421 0	R103, R104	ERDS2TJ184	001 152 2588 8	R226	ERDS2TJ103	001 152 2347 3
R5, R6	ERDS2TJ684	001 152 2451 4	R105, R106	ERDS2TJ242	001 152 3150 0	R227	ERDS2TJ822	001 152 2455 0
R7, R8	ERDS2TJ183	001 152 2429 2	R107, R108	ERDS2TJ473	001 152 2363 3	R228	ERDS2TJ682	001 152 2365 1
R9, R10	ERDS2TJ103	001 152 2347 3	R109, R110	ERDS2TJ242	001 152 3150 0	R231	ERD25TJ473	001 152 1904 0
R11, R12	ERDS2TJ223	001 152 2432 7	R111, R112	ERDS2TJ684	001 152 2451 4	R232	ERDS2TJ223	001 152 2432 7
R13, R14	ERDS2TJ223	001 152 2432 7	R113, R114	ERDS2TJ684	001 152 2451 4	R301	ERD25FJ180	001 152 0208 1
R15, R16	ERDS2TJ155	001 152 2766 8	R117, R118	ERDS2TJ912	001 152 3003 0	R303, R304	ERDS2TJ223	001 152 2432 7
R17, R18	ERDS2TJ223	001 152 2432 7	R151, R152	ERD25TJ223	001 152 1863 2	R305, R306	ERD25FJ180	001 152 0246 5
R19, R20	ERDS2TJ183	001 152 2429 2	R153, R154	ERDS2TJ472	001 152 2362 4	R307	ERD25FJ221	001 152 0260 7
R21, R22	ERDS2TJ331	001 152 2356 2	R157, R158	ERDS2TJ102	001 152 2346 4	(M, MC)		
R23	ERDS2TJ222	001 152 2353 5	R159, R160	ERDS2TJ273	001 152 2436 3	R307	ERG2SJ221	001 151 3783 8
R51	ERD25FJ820	001 152 0353 3	R161, R162	ERDS2TJ822	001 152 2455 0	(E, EG, EK, EH)		
(M, MC)			R163, R164	ERDS2TJ121	001 152 2349 1	(XL, XA, XB)		
R51	ERG2SJ820	001 151 5680 6	R165, R166	ERDS2TJ331	001 152 2356 2	R308	ERD25FJ561	001 152 0327 5
(E, EG, EK, EH)			R167, R168	ERDS2TJ151	001 152 2426 5	(M, MC)		
(XL, XA, XB)			R169, R170	ERDS2TJ222	001 152 2353 5	R308	ERG1SJ561	001 151 4890 2
R52	ERD25FJ820	001 152 0353 3	R171, R172	ERDS2TJ471	001 152 2361 5	(E, EG, EK, EH)		
(M, MC)			R173, R174	ERDS2TJ122	001 152 2423 8	(XL, XA, XB)		
R52	ERG2SJ820	001 151 5680 6	R175, R176	ERDS2TJ102	001 152 2346 4	R315, R316	ERDS2TJ154	001 152 2427 4
(E, EG, EK, EH)			R177, R178	ERDS2TJ330	001 152 2355 3	R317, R318	ERDS2TJ333	001 152 2358 0
(XL, XA, XB)			R179, R180	ERDS2TJ332	001 152 2357 1	R321	ERDS2TJ332	001 152 2357 1
R53	ERD25FJ820	001 152 0353 3	R181, R182	ERDS2TJ100	001 152 2420 1	R322	ERDS2TJ682	001 152 2365 1
(M, MC)			R183, R184	ERDS2TJ102	001 152 2346 4	R323	ERDS2TJ102	001 152 2346 4
R53	ERG2SJ820	001 151 5680 6	R185, R186	ERDS2TJ682	001 152 2365 1	R324	ERD25FJ103	001 152 0216 1
(E, EG, EK, EH)			R201	ERDS2TJ103	001 152 2347 3	R325	ERD2FCG100	001 152 0185 1
(XL, XA, XB)			R202	ERDS2TJ152	001 152 2350 8	(E, EG, EK, EH)		
R54	ERD25FJ820	001 152 0353 3	R203	ERDS2TJ101	001 152 2421 0	(XL, XA, XB)		
(M, MC)			R204, R206	ERDS2TJ473	001 152 2363 3	R325	ERD25FJ100	001 152 0213 4
R54	ERG2SJ820	001 151 5680 6	R207	ERDS2TJ103	001 152 2347 3	(M, MC)		
(E, EG, EK, EH)			R208	ERDS2TJ332	001 152 2357 1	R326	ERD2FCG100	001 152 0185 1
(XL, XA, XB)			R209	ERDS2TJ223	001 152 2432 7	(E, EG, EK, EH)		
R60	ERDS2TJ222	001 152 2353 5	R210	ERDS2TJ333	001 152 2358 0	(XL, XA, XB)		
R61, R62	ERDS2TJ684	001 152 2451 4	R211	ERDS2TJ472	001 152 2362 4	R326	ERD25FJ100	001 152 0213 4
R63, R64	ERD25FJ152	001 152 0237 6	R212	ERD25FJ472	001 152 0311 3	(M, MC)		
R65, R66	ERDS2TJ103	001 152 2347 3	R213	ERD25FJ103	001 152 0216 1	R331, R332	ERD25FJ100	001 152 0213 4
R67, R68	ERDS2TJ103	001 152 2347 3	R214, R215	ERD25TJ223	001 152 1863 2	R333	ERD25TJ473	001 152 1904 0
R69	ERDS2TJ562	001 152 2445 2	R216, R217	ERDS2TJ103	001 152 2347 3	R334	ERD25FJ152	001 152 0237 6
R70	ERDS2TJ471	001 152 2361 5	R218	ERDS2TJ103	001 152 2347 3	R335	ERDS2TJ472	001 152 2362 4
R71, R72	ERDS2TJ102	001 152 2346 4	R219	ERDS2TJ223	001 152 2432 7	R336	ERDS2TJ104	001 152 2348 2
R73, R74	ERDS2TJ562	001 152 2445 2	R220	ERD25TJ223	001 152 1863 2	R337	ERD25TJ154	001 152 0450 3

## RESISTORS & CAPACITORS

Ref. No.	Part No.	Part Code	Ref. No.	Part No.	Part Code	Ref. No.	Part No.	Part Code
R401	ERDS2TJ473	001 152 2363 3	(M, MC)			(E, EG, EK, EH)		
R405, R406	ERDS2TJ112	001 152 3889 4	R599	ERG1SJ151	001 151 2990 7	(XL, XA, XB)		
R409, R410	ERDS2TJ332	001 152 2357 1	(E, EG, EK, EH)			R937	ERDS2TJ271	001 152 2435 4
R411, R412	ERDS2TJ102	001 152 2346 4	(XL, XA, XB)			R938	ERD2FCJ4R7	001 152 2480 9
R413, R414	ERDS2TJ333	001 152 2358 0		ERD25FJ331	001 152 0286 7	(E, EG, EK, EH)		
R415, R416	ERDS2TJ823	001 152 2456 9	R603	ERD25FJ561	001 152 0327 5	(XL, XA, XB)		
R417, R418	ERDS2TJ512	001 152 2596 8	R604	ERD25FJ822	001 152 0355 1		ERG1SJ330	001 151 2991 6
R419, R420	ERDS2TJ683	001 152 2450 5	R607 Δ	ERD25FJ682	001 152 2365 1	(M, MC)		
R421, R422	ERDS2TJ222	001 152 2353 5	R608 Δ	ERD25FJ221	001 152 0260 7	(E, EG, EK, EH)		
R423, R424	ERDS2TJ823	001 152 2456 9	R611	ERGF1SJ221	001 151 3084 8	(M, MC)		
R433	ERD25FJ752	001 152 0349 9	R612	ERDS2TJ152	001 152 2350 8	R611	ERGF1SJ221	001 151 3084 8
R434	ERDS2TJ752	001 152 2894 1	(E, EG, EK, EH)			(XL, XA, XB)		
R435	ERD25TJ473	001 152 1904 0	R711	ERDS2TJ101	001 152 2421 0	(M, MC)		
R444	ERDS2TJ472	001 152 2362 4	R712	ERDS2TJ152	001 152 2350 8	(E, EG, EK, EH)		
R455, R456	ERDS2TJ102	001 152 2346 4	R707	ERDS2TJ102	001 152 2346 4	(XL, XA, XB)		
R457, R458	ERDS2TJ123	001 152 2424 7	R711	ERDS2TJ101	001 152 2421 0	(M, MC)		
R459, R460	ERDS2TJ332	001 152 2357 1	(M, MC)			R711	ERD2FCG101	001 152 0186 0
R461, R462	ERDS2TJ102	001 152 2346 4	(E, EG, EK, EH)			(XL, XA, XB)		
R463, R464	ERDS2TJ333	001 152 2358 0	R713	ERDS2TJ103	001 152 2347 3	(M, MC)		
R465, R466	ERDS2TJ823	001 152 2456 9	R715	ERDS2TJ181	001 152 2428 3	(E, EG, EK, EH)		
R467, R468	ERDS2TJ512	001 152 2596 8	(XL, XA, XB)			(M, MC)		
R469, R470	ERDS2TJ683	001 152 2450 5	R715	ERD2FCG181	001 152 0189 7	(E, EG, EK, EH)		
R471, R472	ERDS2TJ222	001 152 2353 5	(M, MC)			(XL, XA, XB)		
R473, R474	ERDS2TJ823	001 152 2456 9	R716	ERDS2TJ181	001 152 2428 3	(E, EG, EK, EH)		
R491	ERDS2TJ103	001 152 2347 3	(XL, XA, XB)			(M, MC)		
R492	ERD25FJ103	001 152 0216 1	R716	ERD2FCG181	001 152 0189 7	(E, EG, EK, EH)		
R493	ERDS2TJ103	001 152 2347 3	(M, MC)			(XL, XA, XB)		
R495	ERDS2TJ473	001 152 2363 3	R716	ERD2FCG181	001 152 0189 7	(E, EG, EK, EH)		
R500	ERD25FJ102	001 152 0215 2	(M, MC)			(XL, XA, XB)		
R503, R504	ERDS2TJ274	001 152 2437 2	(E, EG, EK, EH)			(XL, XA, XB)		
R505	ERD25FJ822	001 152 0355 1	(XL, XA, XB)			(M, MC)		
R506	ERDS2TJ822	001 152 2455 0	R731	ERDS2TJ103	001 152 2347 3	(E, EG, EK, EH)		
R507, R508	ERDS2TJ122	001 152 2423 8	R733, R734	ERDS2TJ273	001 152 2436 3	(EH, XL, XA) (XB)		
R509, R510	ERDS2TJ154	001 152 2427 4	R735, R736	ERDS2TJ124	001 152 2425 6	(M, MC)		
R511, R512	ERDS2TJ104	001 152 2348 2	R739	ERDS2TJ121	001 152 2349 1	(E, EG, EK, EH)		
R513, R514	ERDS2TJ104	001 152 2348 2	(M, MC)			(XL, XA, XB)		
R515, R516	ERDS2TJ332	001 152 2357 1	R739, R740	ERD2FCG121	001 152 0187 9	(E, EG, EK, EH)		
R517, R518	ERDS2TJ472	001 152 2362 4	(XL, XA, XB)			(M, MC)		
R519, R520	ERDS2TJ153	001 152 2351 7	R740	ERD25FJ121	001 152 0225 0	(E, EG, EK, EH)		
R521, R522	ERDS2TJ333	001 152 2358 0	(M, MC)			(XL, XA, XB)		
R523, R524	ERDS2TJ244	001 152 2767 7	R741, R742	ERD25FJ680	001 152 0341 7	(E, EG, EK, EH)		
R525, R526	ERDS2TJ472	001 152 2362 4	R751	ERDS2TJ222	001 152 2353 5	(XL, XA, XB)		
R527, R528	ERDS2TJ153	001 152 2351 7	R752	ERDS2TJ472	001 152 2362 4	(M, MC)		
R529, R530	ERDS2TJ153	001 152 2351 7	R753	ERD25TJ123	001 152 2077 6	(E, EG, EK, EH)		
R531, R532	ERDS2TJ332	001 152 2357 1	R754, R755	ERDS2TJ333	001 152 2358 0	(XL, XA, XB)		
R533, R534	ERDS2TJ103	001 152 2347 3	R756, R757	ERDS2TJ333	001 152 2358 0	(M, MC)		
R535, R536	ERDS2TJ102	001 152 2346 4	R761, R762	ERDS2TJ392	001 152 2439 0	(E, EG, EK, EH)		
R537, R538	ERDS2TJ151	001 152 2426 5	R901	ERD2FCG100	001 152 0185 1	(XL, XA, XB)		
R539, R540	ERDS2TJ223	001 152 2432 7	(M, MC)			(E, EG, EK, EH)		
R541, R542	ERDS2TJ682	001 152 2365 1	R901	ERD25FJ100	001 152 0213 4	(XL, XA, XB)		
R543, R544	ERDS2TJ102	001 152 2346 4	(M, MC)			(E, EG, EK, EH)		
R547	ERDS2TJ472	001 152 2362 4	R902	ERDS2TJ821	001 152 2454 1	(XL, XA, XB)		
R550	ERD25FJ102	001 152 0215 2	R902	ERDS2TJ332	001 152 2357 1	(M, MC)		
R553, R554	ERDS2TJ473	001 152 2363 3	R903	ERDS2TJ332	001 152 2357 1	(E, EG, EK, EH)		
R555, R556	ERDS2TJ682	001 152 2365 1	R904	ERDS2TJ103	001 152 2347 3	(XL, XA, XB)		
R557, R558	ERDS2TJ152	001 152 2350 8	R905	ERDS2TJ683	001 152 2450 5	(M, MC)		
R559, R560	ERDS2TJ154	001 152 2427 4	R906	ERDS2TJ105	001 152 2422 9	(E, EG, EK, EH)		
R561, R562	ERDS2TJ104	001 152 2348 2	R912, R913	ERD25TJ473	001 152 1904 0	(XL, XA, XB)		
R563, R564	ERDS2TJ563	001 152 2446 1	R914, R915	ERD25TJ473	001 152 1904 0	(M, MC)		
R565, R566	ERDS2TJ332	001 152 2357 1	R919, R920	ERDS2TJ105	001 152 2422 9	(E, EG, EK, EH)		
R567, R568	ERDS2TJ472	001 152 2362 4	R921, R922	ERDS2TJ821	001 152 2454 1	(XL, XA, XB)		
R569, R570	ERDS2TJ153	001 152 2351 7	R923	ERDS2TJ821	001 152 2454 1	(M, MC)		
R571, R572	ERDS2TJ333	001 152 2358 0	R924, R925	ERDS2TJ103	001 152 2347 3	(E, EG, EK, EH)		
R573, R574	ERDS2TJ244	001 152 2767 7	R926	ERDS2TJ473	001 152 2363 3	(XL, XA, XB)		
R575, R576	ERDS2TJ472	001 152 2362 4	R927	ERDS2TJ122	001 152 2423 8	(M, MC)		
R577, R578	ERDS2TJ153	001 152 2351 7	R928	ERDS2TJ561	001 152 2364 2	(E, EG, EK, EH)		
R579, R580	ERDS2TJ153	001 152 2351 7	R929	ERDS2TJ471	001 152 2361 5	(XL, XA, XB)		
R581, R582	ERDS2TJ332	001 152 2357 1	R930	ERDS2TJ122	001 152 2423 8	(M, MC)		
R583, R584	ERDS2TJ103	001 152 2347 3	R932	ERDS2TJ103	001 152 2347 3	(E, EG, EK, EH)		
R585, R586	ERDS2TJ102	001 152 2346 4	R933	ERGS2SJ330	001 151 4037 1	(XL, XA, XB)		
R587, R588	ERDS2TJ151	001 152 2426 5	(M, MC)			(E, EG, EK, EH)		
R589, R590	ERDS2TJ153	001 152 2351 7	R934	ERDS2TJ103	001 152 2347 3	(XL, XA, XB)		
R591, R592	ERDS2TJ472	001 152 2362 4	R935	ERX1SJ4R7	001 151 2922 9	(M, MC)		
R593, R594	ERDS2TJ102	001 152 2346 4	(E, EG, EK, EH)			(XL, XA, XB)		
R597	ERDS2TJ472	001 152 2362 4	R936	ERX2SJ4R7	001 151 3611 7	(M, MC)		
R598	ERDS2TJ103	001 152 2347 3						
R599	ERD25FJ151	001 152 0236 7						

## RESISTORS & CAPACITORS

Ref. No.	Part No.	Part Code	Ref. No.	Part No.	Part Code	Ref. No.	Part No.	Part Code
C321, C322	ECBT1H561KB5	001 103 9079 1	C503, C504	ECKD1H122KB	001 103 1459 5	C585, C586	ECQM1H472JZ	001 106 0801 0
C323, C324	ECQM1H223JZ	001 106 0739 9	C505, C506	ECQM1H183JZ	001 106 0723 7	C587, C588	ECCD1H391J	001 103 6042 6
C325, C326	ECQV1H104JZ	001 106 2571 7	C511, C512	ECEA1HSR33	001 120 3248 9	C589	ECEA1HU010	001 120 2842 1
C327, C328	ECQM1H103JZ	001 106 0667 8	C513, C514	ECCD1H391J	001 103 6050 7	C590, C591	ECEA1CU100	001 120 2905 3
C330	ECEA1CU100	001 120 2905 3	C515, C516	ECEA50ZR68	001 120 1290 5	C592, C597	ECEA1CU100	001 120 2905 3
C403, C404	ECQM1H472JZ	001 106 0801 0	C517, C518	ECQV1H104JZ	001 106 2571 7	C599	ECEA1AU331	001 120 3649 6
C405, C406	ECEA1CU100	001 120 2905 3	C519, C520	ECQV1H104JZ	001 106 2571 7	C601	ECEA25V2200	001 120 3126 8
C407, C408	ECQM1H473JZ	001 106 0810 9	C521, C522	ECQM1H332JZ	001 106 0774 6	C602 Δ	ECEA25V2200	001 120 3126 8
C409, C410	ECQV1H224JZ	001 106 3625 6	C523, C524	ECQM1H332JZ	001 106 0774 6	C603, C604 Δ	ECKD1H223PF	001 103 1510 9
C411, C412	ECEA50ZR68	001 120 1290 5	C525, C526	ECQV1H391J	001 103 0605 7	C605, C606 Δ	ECEA1CU331	001 120 3200 5
C413, C414	ECQM1H103JZ	001 106 0667 8	C527, C528	ECQM1H333JZ	001 106 0779 1	C607	ECEA1CU332	001 120 3201 4
C415, C416	ECQM1H472JZ	001 106 0801 0	C529, C530	ECEA1HSR33	001 120 3248 9	C610 Δ	ECKD1H223PF	001 103 1510 9
C417, C418	ECEA1CU100	001 120 2905 3	C531, C532	ECEA16Z10	001 120 0699 8	C615 Δ	ECKDKC103PF2	001 103 3734 7
C419, C420	ECQM1H473JZ	001 106 0810 9	C533, C534	ECEA0JU470	001 120 3125 9	C616	ECEA1CU101	001 120 2926 8
C421, C422	ECQV1H224JZ	001 106 3625 6	C535, C536	ECQM1H472JZ	001 106 0801 0	C617	ECEA1VU470	001 120 2843 0
C423, C424	ECEA50ZR68	001 120 1290 5	C537, C538	ECQM1H153JZ	001 106 0704 0	C701	ECQV1H393JZ	001 106 5328 4
C431, C432	ECEA1EU4R7	001 120 2840 3	C539	ECEA1HU010	001 120 2842 1	C711, C712	ECEA1EU4R7	001 120 2840 3
C433, C434	ECEA1CU100	001 120 2905 3	C540, C541	ECEA1CU100	001 120 2905 3	C715, C716	RCBS1H220JCY	001 103 5600 2
C444	ECEA1HU010	001 120 2842 1	C542	ECEA1CU100	001 120 2905 3	C752	ECQM1H103JZ	001 106 0667 8
C451, C452	ECEA1CU100	001 120 2905 3	C543, C544	ECQM1H332JZ	001 106 0774 6	C901	ECKD1H122KB	001 103 1459 5
C453, C454	ECQM1H472JZ	001 106 0801 0	C547	ECEA1CKS100	001 120 2600 7	C902	ECEA1CU100	001 120 2905 3
C455, C456	ECEA1CU100	001 120 2905 3	C561, C562	ECEA1HU010	001 120 2842 1	C903 Δ	E	

# WIRING CONNECTION DIAGRAM

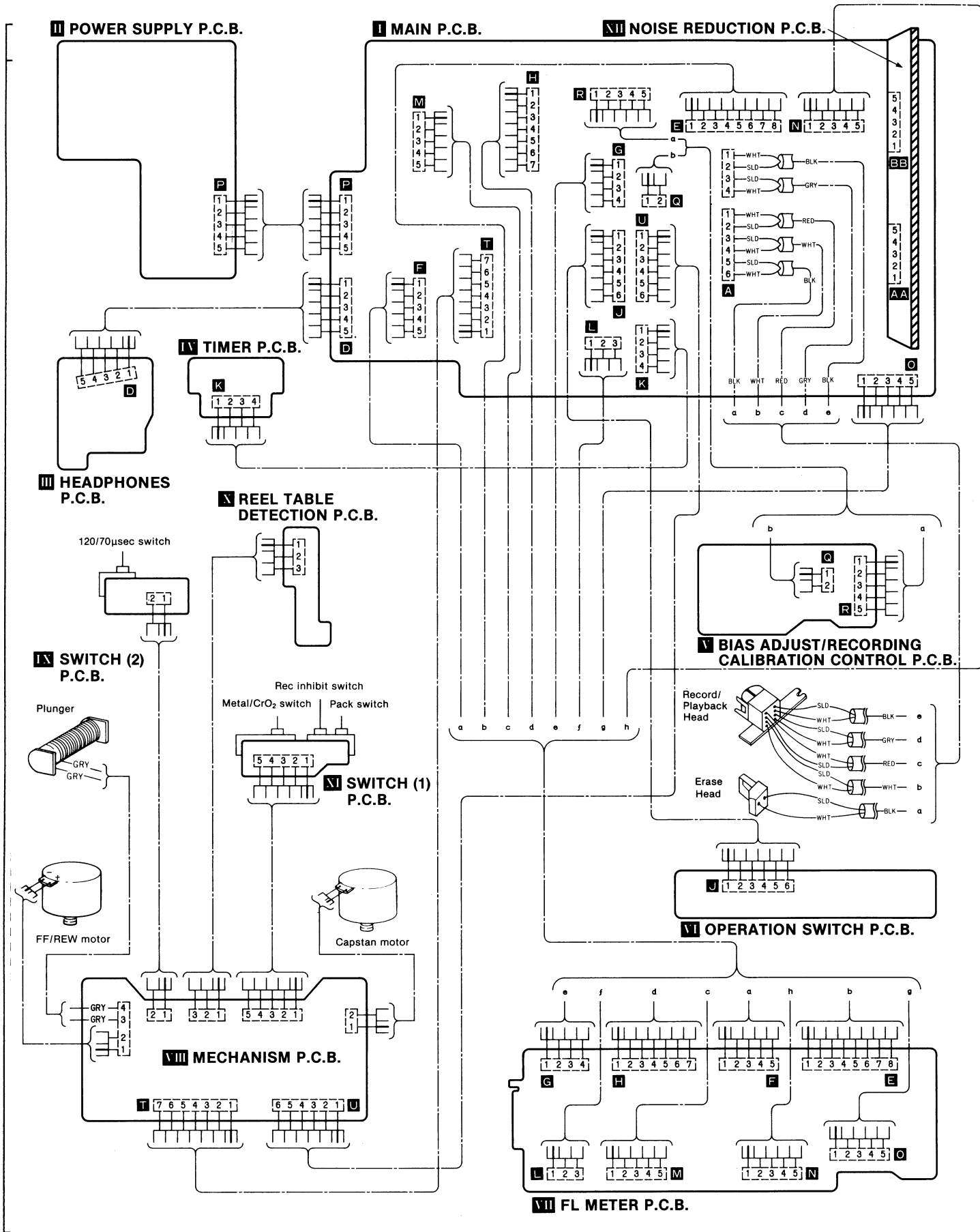

**PRINTED CIRCUIT BOARDS**

**VI OPERATION SWITCH P.C.B.**

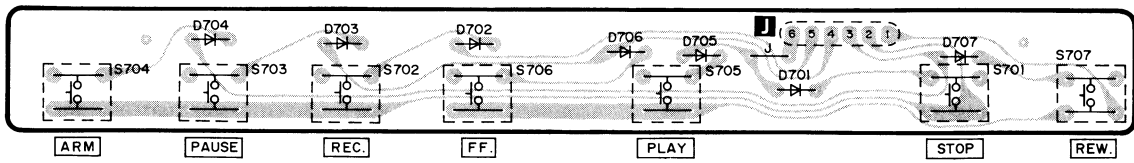

**IV TIMER P.C.B.**

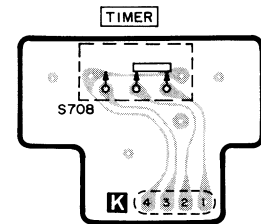

**XII NOISE REDUCTION P.C.B.**

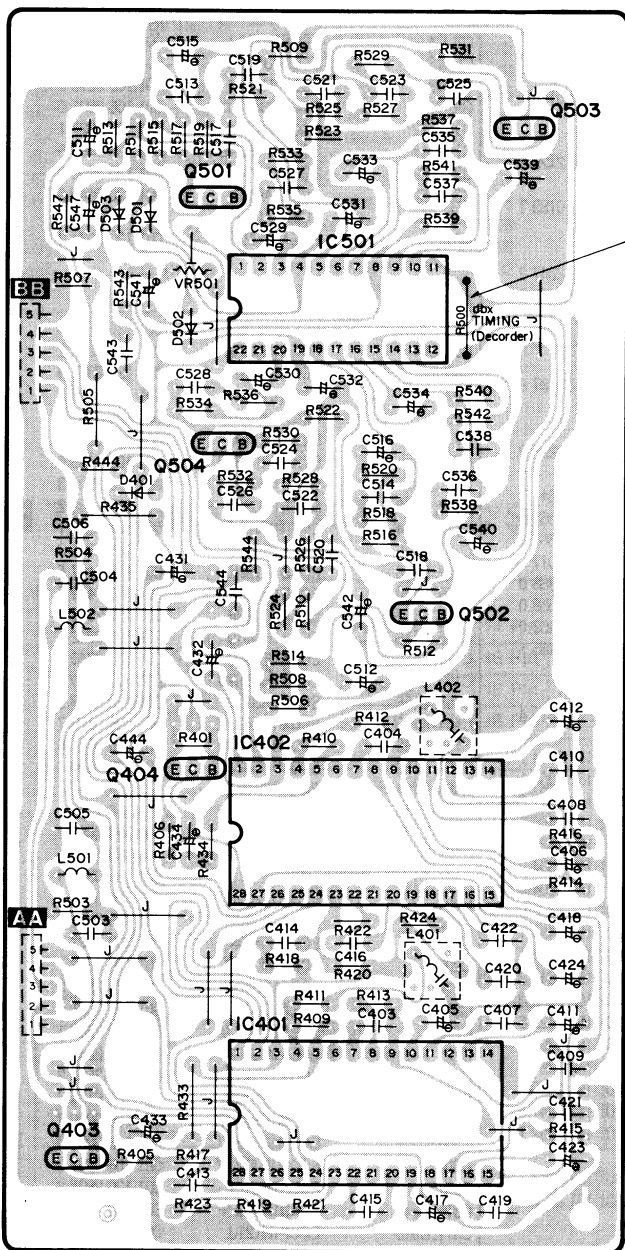

**V BIAS ADJUST/RECORDING CALIBRATION CONTROL P.C.B.**

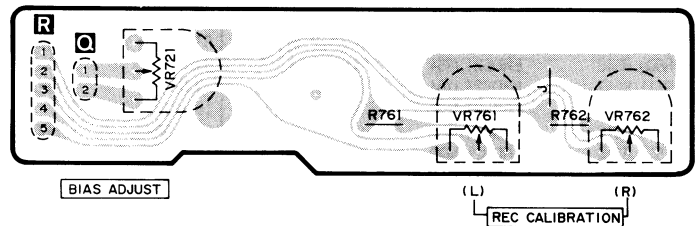

**III HEADPHONES P.C.B.**

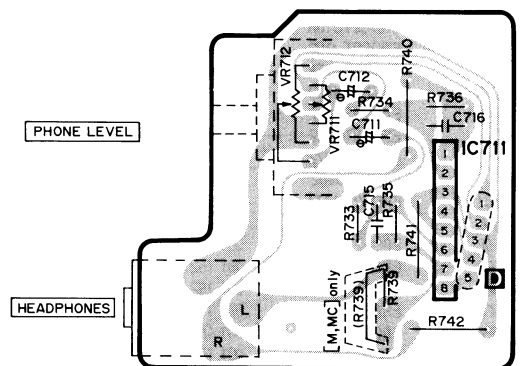

**VIII MECHANISM P.C.B.**

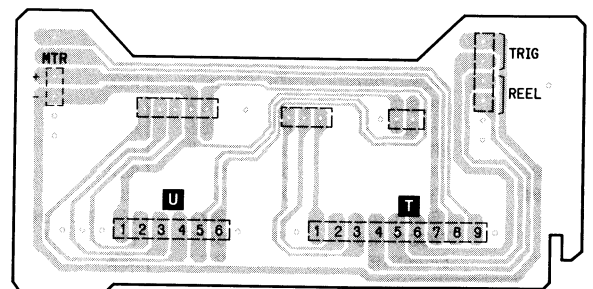

### VII FL METER P.C.B.

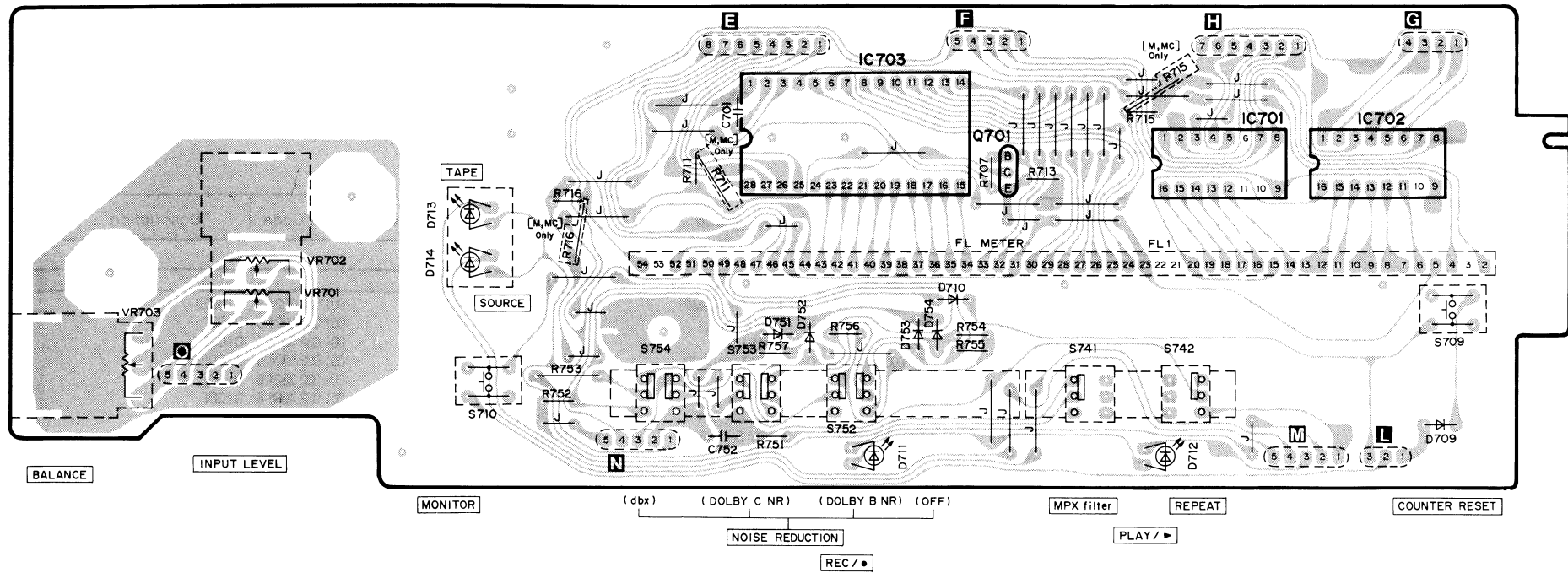

### I MAIN P.C.B.

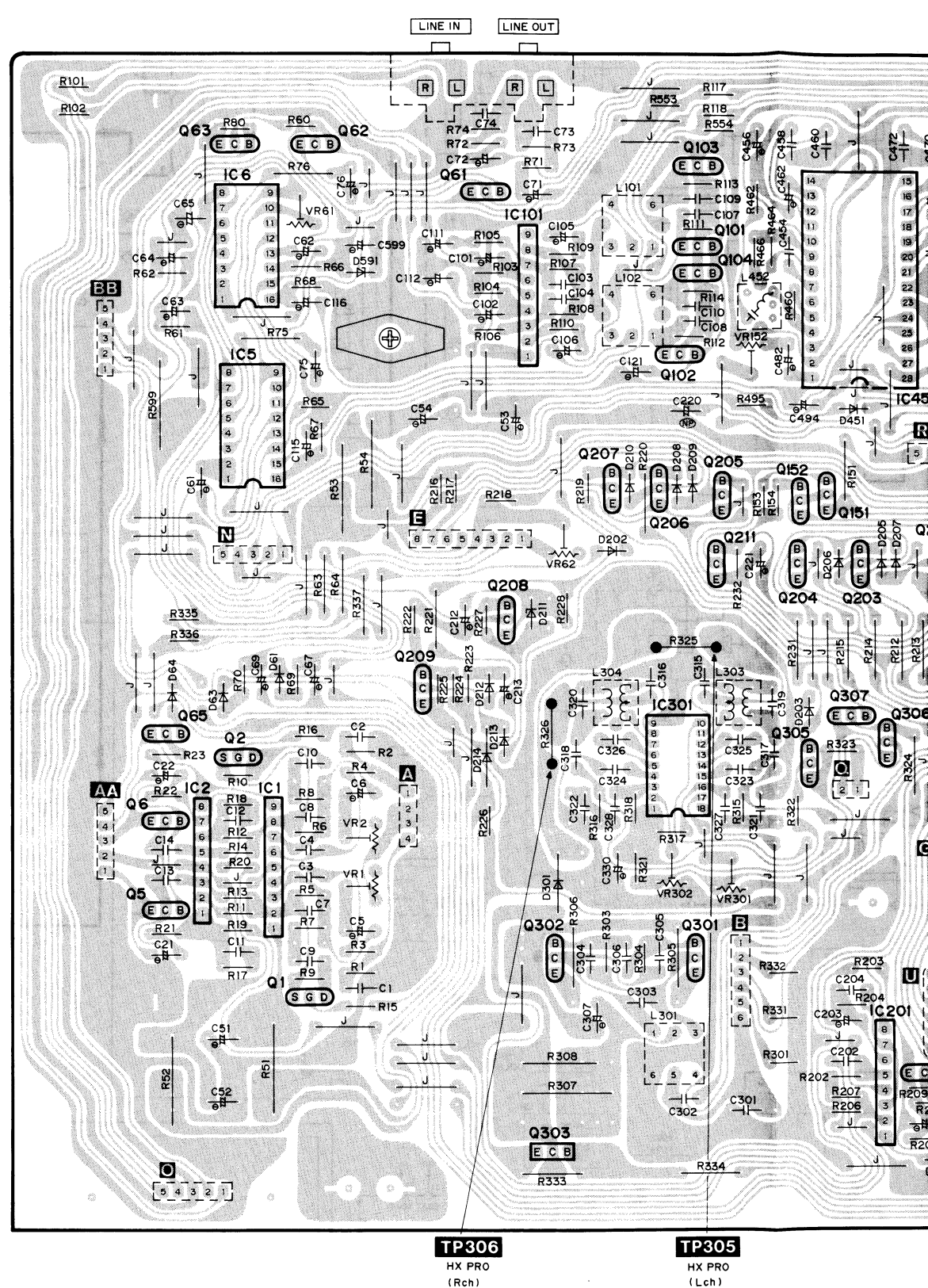

### II POWER SUPPLY P.C.B. [E, EK, EG, EH, XL, XA, XB]

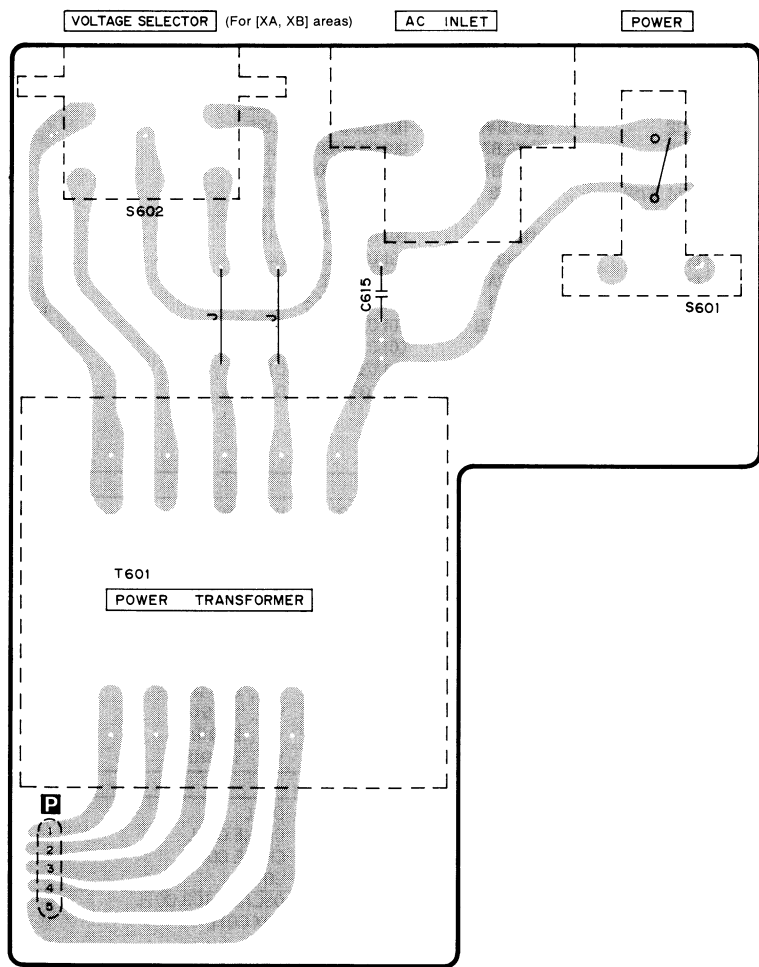

### II POWER SUPPLY P.C.B. [M, MC]

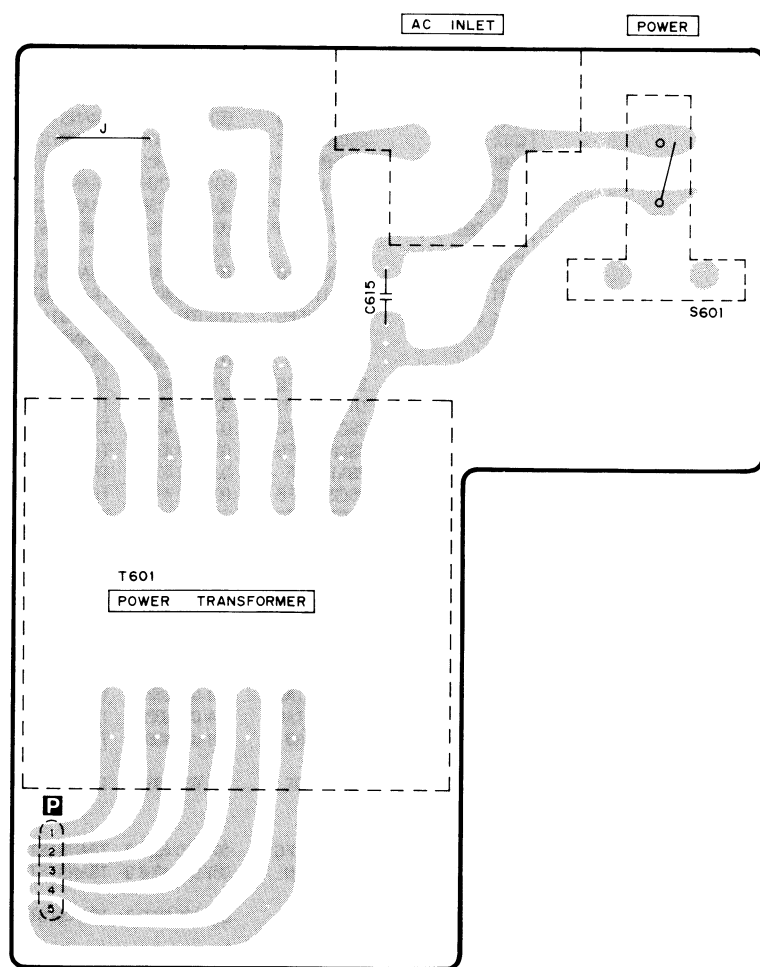

I MAIN P.C.B.

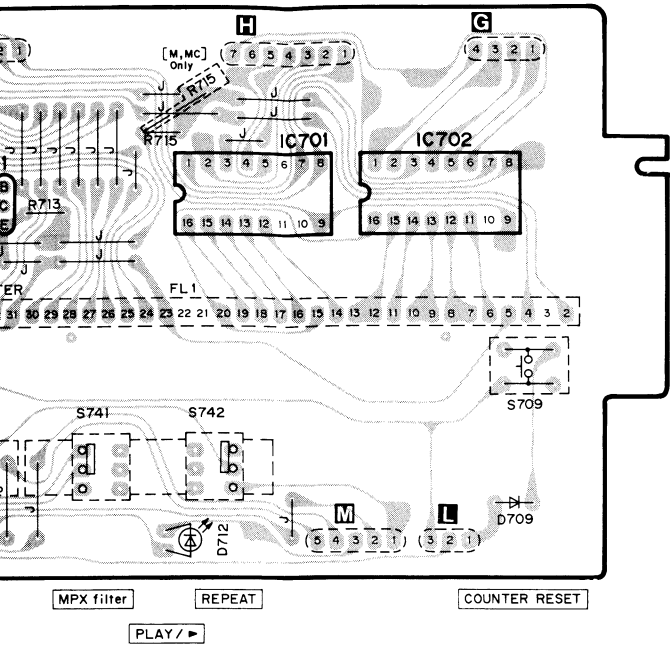

P.C.B. [M, MC]

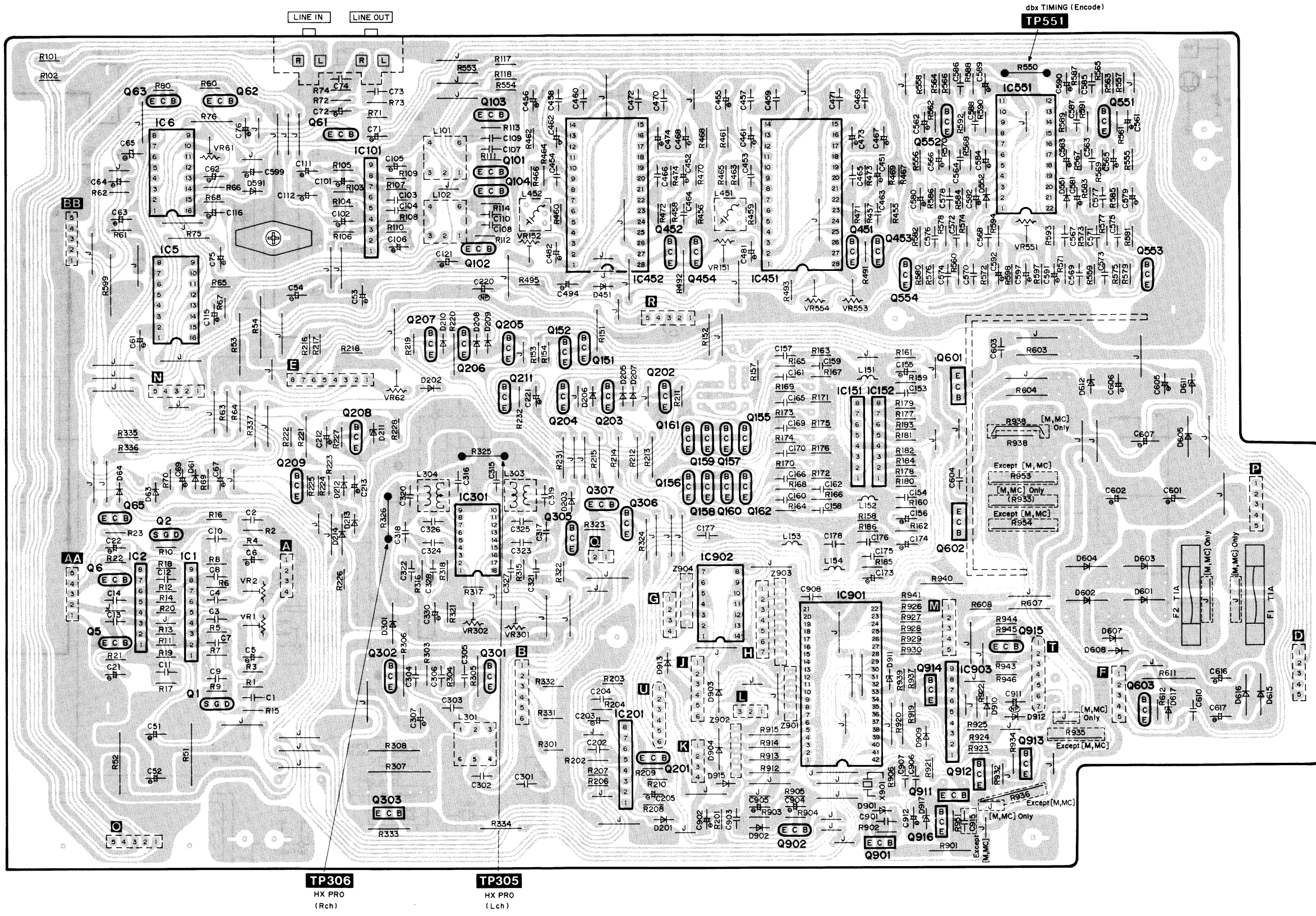
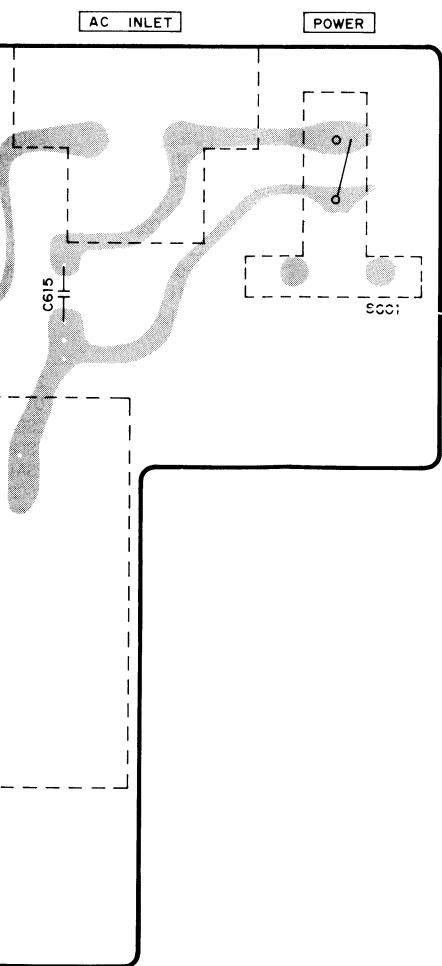

# BLOCK DIAGRAM

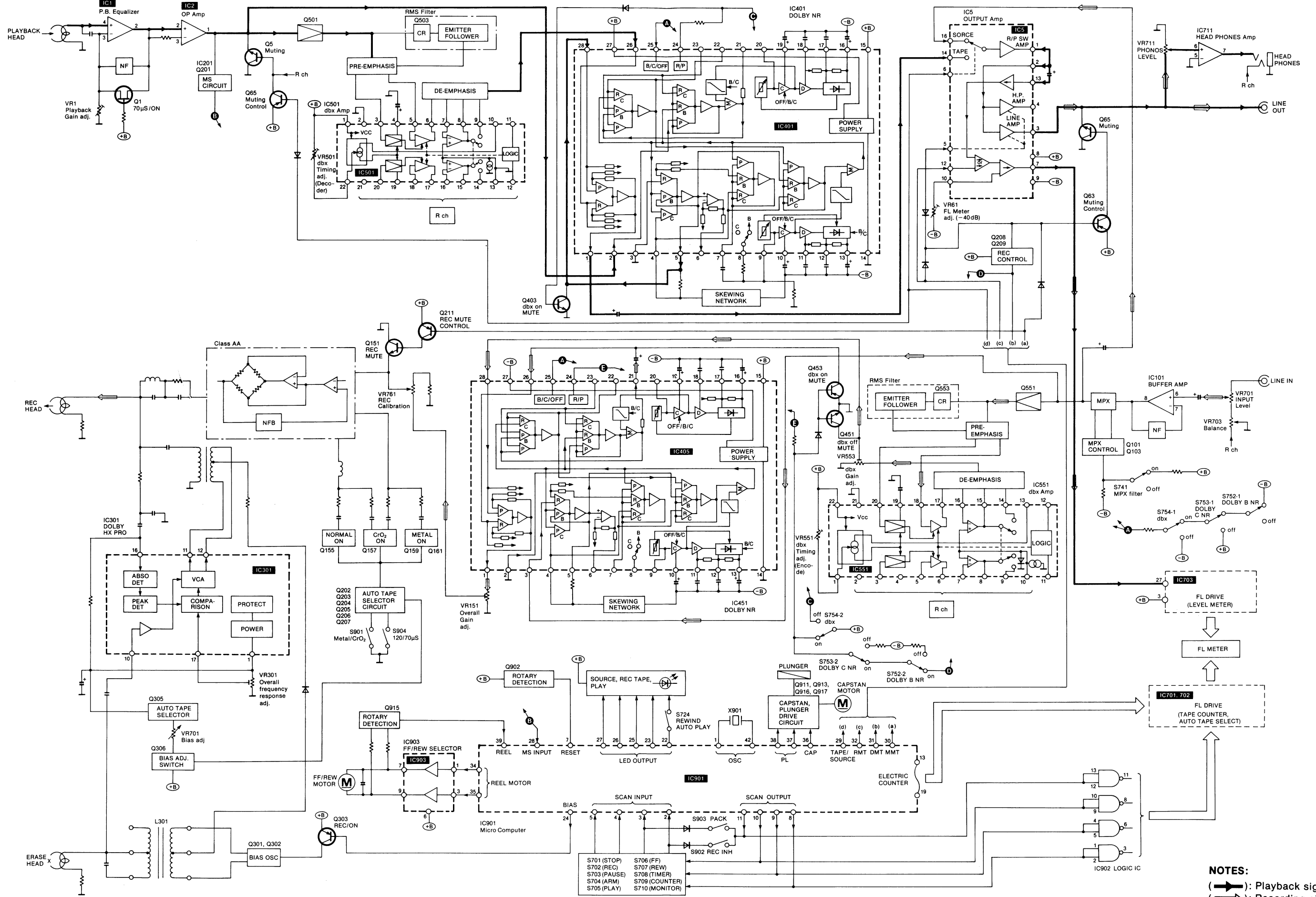

**NOTES:**  
 (→): Playback signal  
 (⇄): Recording signal



# REPLACEMENT PARTS LIST

**Notes:** \* Important safety notice:

Components identified by  $\Delta$  mark have special characteristics important for safety. When replacing any of these components use only manufacturer's specified parts.

\* Bracketed indications in Ref. No. columns specify the area.

Parts without these indications can be used for all areas.

Ref. No.	Part No.	Part Code	Description	Ref. No.	Part No.	Part Code	Description
<b>INTEGRATED CIRCUITS</b>				<b>(XL, XA, XB)</b>			
IC1	AN6557F	001 060 7688 6	I.C., EQUALIZER	<b>DIODES</b>			
IC2	M5218L	001 060 3798 7	I.C., OPERATION AMP.	D61, D63	1SS133	001 032 3324 5	DIODE
IC5, IC6	AN6203	001 060 5005 1	I.C., OUTPUT AMP.	D64, D201	1SS133	001 032 3324 5	DIODE
IC101	AN6557F	001 060 7688 6	I.C., EQUALIZER	D202, D203	1SS133	001 032 3324 5	DIODE
IC151, IC152	M5218L	001 060 3798 7	I.C., OPERATION AMP.	D206, D207	1SS133	001 032 3324 5	DIODE
IC201	M5218L	001 060 3798 7	I.C., OPERATION AMP.	D208, D209	1SS133	001 032 3324 5	DIODE
IC301	UPC1297CA	001 061 3671 6	I.C., DOLBY HX PRO	D211	MTZ6R8B	001 032 4068 8	DIODE
IC401, IC402	TEA0665	001 060 7933 2	I.C., DOLBY B, C NR	D212, D213	1SS133	001 032 3324 5	DIODE
IC451, IC452	TEA0665	001 060 7933 2	I.C., DOLBY B, C NR	D214, D301	MA162A	001 032 0493 1	DIODE
IC501, IC551	AN6291	001 060 4112 3	I.C., DBX AMP.	D401, D451	1SS133	001 032 3324 5	DIODE
IC701, IC702	AN6280	001 060 3742 3	I.C., FL DRIVE	D501, D502	1SS133	001 032 3324 5	DIODE
IC703	AN6870	001 060 3746 9	I.C., FL DRIVE	D503, D551	1SS133	001 032 3324 5	DIODE
IC711	M5218L	001 060 3798 7	I.C., OPERATION AMP.	D552	1SS133	001 032 3324 5	DIODE
IC901	LM6405G-2104	001 061 5238 1	I.C., MICROCOMPUTER	D591	MTZ5R1B	001 032 6202 2	DIODE
IC902	M74LS00P	001 060 1024 4	I.C., LOGIC	D601, D602 $\Delta$	SVD1SR35200A	001 032 3951 4	RECTIFIER
IC903	BA6218	001 061 1421 0	I.C., MOTOR DRIVE	D603, D604 $\Delta$	SVD1SR35200A	001 032 3951 4	RECTIFIER
<b>TRANSISTORS</b>				D605 $\Delta$	SVD1SR35200A	001 032 3951 4	RECTIFIER
Q1, Q2	2SD381D	001 030 7411 1	TRANSISTOR	D607, D608	1SS133	001 032 3324 5	DIODE
Q5, Q6	2SC2603EFG	001 030 4301 8	TRANSISTOR	D611, D612	MTZ11BT77	001 032 7873 5	DIODE
Q61, Q62	2SC2603EFG	001 030 4301 8	TRANSISTOR	D615, D616 $\Delta$	SVD1SR35200A	001 032 3951 4	RECTIFIER
Q63, Q65	DTA114ESTP	001 030 5275 9	TRANSISTOR	D617	MTZ13CT77	001 033 0331 3	DIODE
Q101, Q102	2SA1115EF	001 030 4055 3	TRANSISTOR	D701, D702	1SS133	001 032 3324 5	DIODE
Q103, Q104	2SA1115EF	001 030 4055 3	TRANSISTOR	D703, D704	1SS133	001 032 3324 5	DIODE
Q151, Q152	2SD1468R	001 030 2894 0	TRANSISTOR	D705, D706	1SS133	001 032 3324 5	DIODE
Q155, Q156	2SC2603EFG	001 030 4301 8	TRANSISTOR	D707, D709	1SS133	001 032 3324 5	DIODE
Q157, Q158	2SC2603EFG	001 030 4301 8	TRANSISTOR	D710	1SS133	001 032 3324 5	DIODE
Q159, Q160	2SC2603EFG	001 030 4301 8	TRANSISTOR	D711	SLV31VC3	001 032 4525 4	L.E.D
Q161, Q162	2SC2603EFG	001 030 4301 8	TRANSISTOR	D712	SLV31MC3	001 032 6353 8	L.E.D
Q201	2SC2603EFG	001 030 4301 8	TRANSISTOR	D713	SVGLB74MG3HL	001 032 7888 8	L.E.D
Q202, Q203	DTA144ESTP	001 030 7166 5	TRANSISTOR	D714	SVGLB74VR3HL	001 032 9300 9	L.E.D
Q204, Q205	DTA144ESTP	001 030 7166 5	TRANSISTOR	D751, D752	1SS133	001 032 3324 5	DIODE
Q206, Q207	DTA144ESTP	001 030 7166 5	TRANSISTOR	D753, D754	1SS133	001 032 3324 5	DIODE
Q208	2SA1115EF	001 030 4055 3	TRANSISTOR	D901	MTZ5R6B	001 032 9506 7	DIODE
Q209	2SC2603EFG	001 030 4301 8	TRANSISTOR	D902	1SS133	001 032 3324 5	DIODE
Q211	2SA1115EF	001 030 4055 3	TRANSISTOR	D903, D904	MA162A	001 032 0493 1	DIODE
Q301, Q302	2SC2603EFG	001 030 4301 8	TRANSISTOR	D909, D910	1SS133	001 032 3324 5	DIODE
Q303	2SB1237TAQR	001 030 6929 0	TRANSISTOR	D911	MTZ5R6B	001 032 9506 7	DIODE
Q305	DTC144A	001 030 2708 7	TRANSISTOR	D912, D913	1SS133	001 032 3324 5	DIODE
Q306	2SC2603EFG	001 030 4301 8	TRANSISTOR	D915	1SS133	001 032 3324 5	DIODE
Q307	DTC114ESTP	001 030 5025 5	TRANSISTOR	D917	MTZ11BT77	001 032 7873 5	DIODE
Q403, Q404	2SC2603EFG	001 030 4301 8	TRANSISTOR	(E, EG, EK)			
Q451, Q452	2SC2603EFG	001 030 4301 8	TRANSISTOR	(EH, XL, XA)			
Q453, Q454	2SA1115EF	001 030 4055 3	TRANSISTOR	(XB)			
Q501, Q502	2SC2603EFG	001 030 4301 8	TRANSISTOR	<b>VARIABLE RESISTORS</b>			
Q503, Q504	2SC2603EFG	001 030 4301 8	TRANSISTOR	VR1, VR2	QVNB3A00B151	001 180 3085 4	V.R., 150 $\Omega$ (B)
Q551, Q552	2SC2603EFG	001 030 4301 8	TRANSISTOR	VR61	EVND4AA00B23	001 180 2317 1	V.R., 2K $\Omega$ (B)
Q553, Q554	2SC2603EFG	001 030 4301 8	TRANSISTOR	VR62	EVND4AA00B24	001 180 2244 1	V.R., 20K $\Omega$ (B)
Q601	2SD1762DE	001 030 6930 7	TRANSISTOR	VR151, VR152	EVND4AA00B14	001 180 2242 3	V.R., 10K $\Omega$ (B)
Q602	2SB1185DEF	001 030 5691 7	TRANSISTOR	VR301, VR302	EVND4AA00B24	001 180 2244 1	V.R., 20K $\Omega$ (B)
Q603, Q701	2SC2603EFG	001 030 4301 8	TRANSISTOR	VR501, VR551	EVND4AA00B23	001 180 2317 1	V.R., 2K $\Omega$ (B)
Q901	2SD1225RM	001 030 4356 3	TRANSISTOR	VR553, VR554	EVND4AA00B14	001 180 2242 3	V.R., 10K $\Omega$ (B)
Q902	2SC2603EFG	001 030 4301 8	TRANSISTOR	VR701, VR702	EWK94A033A54	001 174 8883 8	V.R., 50K $\Omega$ (A)
Q911, Q912	2SB1237TAQR	001 030 6929 0	TRANSISTOR	VR703	EWHFDAF20G25	001 174 8947 9	V.R., 200K $\Omega$ (G)
Q913	2SB1237TAQR	001 030 6929 0	TRANSISTOR	VR711, VR712	EWCSNA020A14	001 174 8940 6	V.R., 10K $\Omega$ (A)
Q914	2SD1225RM	001 030 4356 3	TRANSISTOR	VR721	EVJMLAF20B23	001 174 9173 7	V.R., 2K $\Omega$ (B)
(M, MC)				VR761, VR762	EVJMLA018B14	001 174 9176 4	V.R., 10K $\Omega$ (B)
Q914	2SD1762DE	001 030 6930 7	TRANSISTOR	<b>COILS AND TRANSFORMERS</b>			
(E, EG, EK, EH)				L101, L102	QLB40048	001 210 7275 9	COIL
(XL, XA, XB)				L151, L152	SLQX272-1YT	001 211 0649 2	CHOKE COIL
Q915	2SC2603EFG	001 030 4301 8	TRANSISTOR	L153, L154	SLQX303-1K	001 211 1756 6	CHOKE COIL
Q916	2SD1225RM	001 030 4356 3	TRANSISTOR	L301	QLB0202	001 210 9090 8	COIL
(M, MC)				L303, L304	SL09B1-K	001 211 3508 2	OSCILLATOR COIL
Q916	2SD1762DE	001 030 6930 7	TRANSISTOR	L401, L402	SLM1B8-K	001 211 2731 1	MPX COIL
(E, EG, EK, EH)				L451, L452	ELM7Q306A	001 210 6560 1	COIL

Ref. No.	Part No.	Part Code	Description	Ref. No.	Part No.	Part Code	Description
L501, L502 T601 Δ (E, EG, EH)	SLQX272-1YT	001 211 0649 2	CHOKE COIL	F1, F2 Δ (E, EG, EK, EH)	XBA2C10TB0	002 380 1351 1	250V, T1A
T601 Δ (EK, XL)	SLT5L279-W	001 202 9096 8	POWER TRANSFORMER	(XL, XA, XB)			
T601 Δ (XA, XB)	SLT5L280-W	001 202 9097 7	POWER TRANSFORMER	SWITCHES			
T601 Δ (M, MC)	SLT5L281-W	001 202 9098 6	POWER TRANSFORMER	S601 Δ	ESB249V	003 435 5877 0	POWER SWITCH
COMPONENT COMBINATIONS				S602 Δ	SSR227	003 430 2365 6	VOLTAGE SELECTOR
Z901	EXBF5E103J8R	001 230 2886 6	COMPONENT COMBINATION	(EK, XL, XA)			
Z902	EXBF5E472J8R	001 230 2223 9	COMPONENT COMBINATION	(XB)			
Z903	EXBF8E472J8R	001 230 2622 8	COMPONENT COMBINATION	S701, S702	EVQQA05G	003 439 2072 1	SW, OPERATION
Z904	EXBF5E472J8R	001 230 2223 9	COMPONENT COMBINATION	S703, S704	EVQQA05G	003 439 2072 1	SW, OPERATION
OSCILLATORS				S705, S706	EVQQA05G	003 439 2072 1	SW, OPERATION
X901	SVFKBR800H-K	001 241 1414 7	QUARTZ OSCILLATOR	S707	EVQQA05G	003 439 2072 1	SW, OPERATION
DISPLAYS				S708	QSS1306	003 431 2419 4	SW, TIMER
FL1	SADBG404ZK	001 001 0474 7	DISPLAY	S709, S710	EVQQA05G	003 439 2072 1	SW, COUNTER RESET/MONITOR
FUSES				S741, S742	SSH2121	003 435 5841 2	SW, MPX SEL.
				S752, S753	SSH4108	003 435 6138 4	SW, NR SEL.
				S754	SSH4108	003 435 6138 4	SW, NR SEL.
				S901	SMQA1059	003 435 6132 0	SW, DET.
				S902, S903	SMQA1058	003 435 6131 1	SW, DET.
				S904	SMQA1059	003 435 6132 0	SW, METAL

Ref. No.	Part No.	Part Code	Description	Ref. No.	Part No.	Part Code	Description
CABINET AND CHASSIS				34	SJS5421	003 400 1643 5	CONNECTOR(4-P)
1 Δ (XL)	SJSD16	003 400 7436 6	AC INLET	34	SJS5629	003 400 5917 2	CONNECTOR(6-P)
1 Δ (M, MC, E, EG)	SJS9236	003 403 4660 7	AC INLET	35	SUBM14	016 712 0347 4	ROD
(EK, EH, XA)				36	SBC666-5	016 702 6679 9	BUTTON, POWER
(XB)				37	SBDM10ZK0A	016 700 1952 1	KNOB
2	SMX897	016 600 0483 0	SHIELD COVER	38	SBN1185-2	016 700 1614 6	KNOB
(E, EG, EK, EH)				39	SGXM46	016 846 3664 7	ORNAMENT
(XL, XA, XB)				40	SGPM10ZF1B		CHASSIS
3	SMNM11	016 632 1852 3	BRACKET	(E, EG)			
4	SMNM13	016 632 1853 2	BRACKET	40	SGPM10ZF1C		CHASSIS
5	SHRM9020	016 652 0721 5	FL HOLDER	(M, MC)			
6	SMPSB905-KE		L.E.D. BLOCK	40	SGPM10ZF2A		CHASSIS
7	SHRM9023	016 652 0829 4	L.E.D. HOLDER	(EK, XL, XA)			
8	SMNM14	016 632 1916 4	BRACKET	(XB)			
9	QJA0455ZC	003 400 5218 2	HEADPHONES JACK	40	SGPSB905-KG		CHASSIS
10	SJT30539MB	003 410 6148 9	LUG TERMINAL	(EG, EH)			
11	SJF3057N	003 410 3829 3	TERMINAL BOARD	40	SGPSB905-KL		CHASSIS
12	SJT3415	003 403 3909 5	CONNECTOR(4-P)	(XL)			
12	SJT3611	003 410 6000 8	CONNECTOR(6-P)	40	SGPSB905-KX		CHASSIS
13	SJT30243-V	003 410 6222 6	CONNECTOR(2-P)	(XA, XB)			
13	SJT30340LX-V	003 410 6075 9	CONNECTOR(3-P)	41	SKLD5	016 828 0321 1	INSULATOR
13	SJT30440LX-V	003 410 6076 8	CONNECTOR(4-P)	42	SYTM10ZC0A	016 700 1989 8	DIAL, REC LEVEL
13	SJT30540LX-V	003 410 5996 1	CONNECTOR(5-P)	43	SMNM10-1	016 632 1915 5	COVER
13	SJT30640LX-V	003 410 6149 8	CONNECTOR(6-P)	44	SBCM30ZK0A	016 702 6901 2	BUTTON
13	SJT30740LX-V	003 410 5990 7	CONNECTOR(7-P)	45	SMNM15	016 632 1917 3	BRACKET
13	SJT30840LX-V	003 410 5998 9	CONNECTOR(8-P)	(EK, XL, XA)			
14	SHR9762	016 652 0497 4	SPACER	(XB)			
15	QTF1054	003 415 0168 4	FUSE HOLDER	46	SME103-5	016 601 0461 1	MAGNETIC SHIELD PARTS
(E, EG, EK, EH)				49	SMY890	016 611 0015 3	HEATSINK
(XL, XA, XB)				50	SKC1850K991	016 800 2466 9	CABINET
16	SGXSB80R-KAN	016 846 3666 5	CASSETTE HOLDER	51	SYKM38		CASSETTE LID
16-1	QBP2006A	015 727 0706 8	SPRING	SCREWS, WASHERS & NUTS			
17	SUSM12	016 726 0913 0	SPRING	61	XNS8FZ	005 507 0573 8	NUT
18	SGWSB905-KE		FRONT PANEL	62	XNS7	005 507 1202 8	NUT
19	SBCM100		BUTTON, OPERATION	63	SFXGQ06N01	005 500 4983 3	SCREW
20	SHRSB905-KM	016 652 0876 7	BUTTON GUIDE	64	XTV3+10BFN	005 501 0818 6	SCREW
21	SGUM31ZT1A	016 842 1651 0	INDICATOR	67	XTV3+6FR	005 501 1321 2	SCREW
22	SGUM32ZT0A	016 842 1652 9	INDICATOR	68	XTB3+8JFZ	005 501 0138 3	SCREW
23	SBCM80ZK0A	016 702 7105 8	BUTTON, MONITOR	69	XTB3+12JFZ	005 501 2078 0	SCREW
24	SBCM20ZK0A	016 702 6902 1	BUTTON, RESET	(EK, XL, XA)			
25	SBDM20ZK0A	016 700 1950 3	KNOB, TIMER	(XB)			
26	SHMM60H70	016 643 1084 8	SPACER	70	XTS3+8JFZ	005 501 2270 2	SCREW
27	SGYSB905-KE		FRONT GRILLE	71	XTV3+10JR	005 501 1142 3	SCREW
28	QYF0627A	015 641 0945 0	DAMPER GEAR	72	XTBS3+8JFZ1	005 501 2523 0	SCREW
29	SBCM50ZK0A	016 702 6899 9	BUTTON, EJECT	75	XTB3+6JR	005 501 4755 8	SCREW
30	SMQM30016	016 718 3366 9	LEVER	77	XTB3+8JFZ	005 501 0138 3	SCREW
33	SJT783	003 410 6001 7	CONTACT	78	SNE2118-1	005 500 5004 1	SCREW
				79	XTS3+12JR		SCREW
				80	XYN3+F8	005 503 0513 0	SCREW

# CABINET PARTS LOCATION

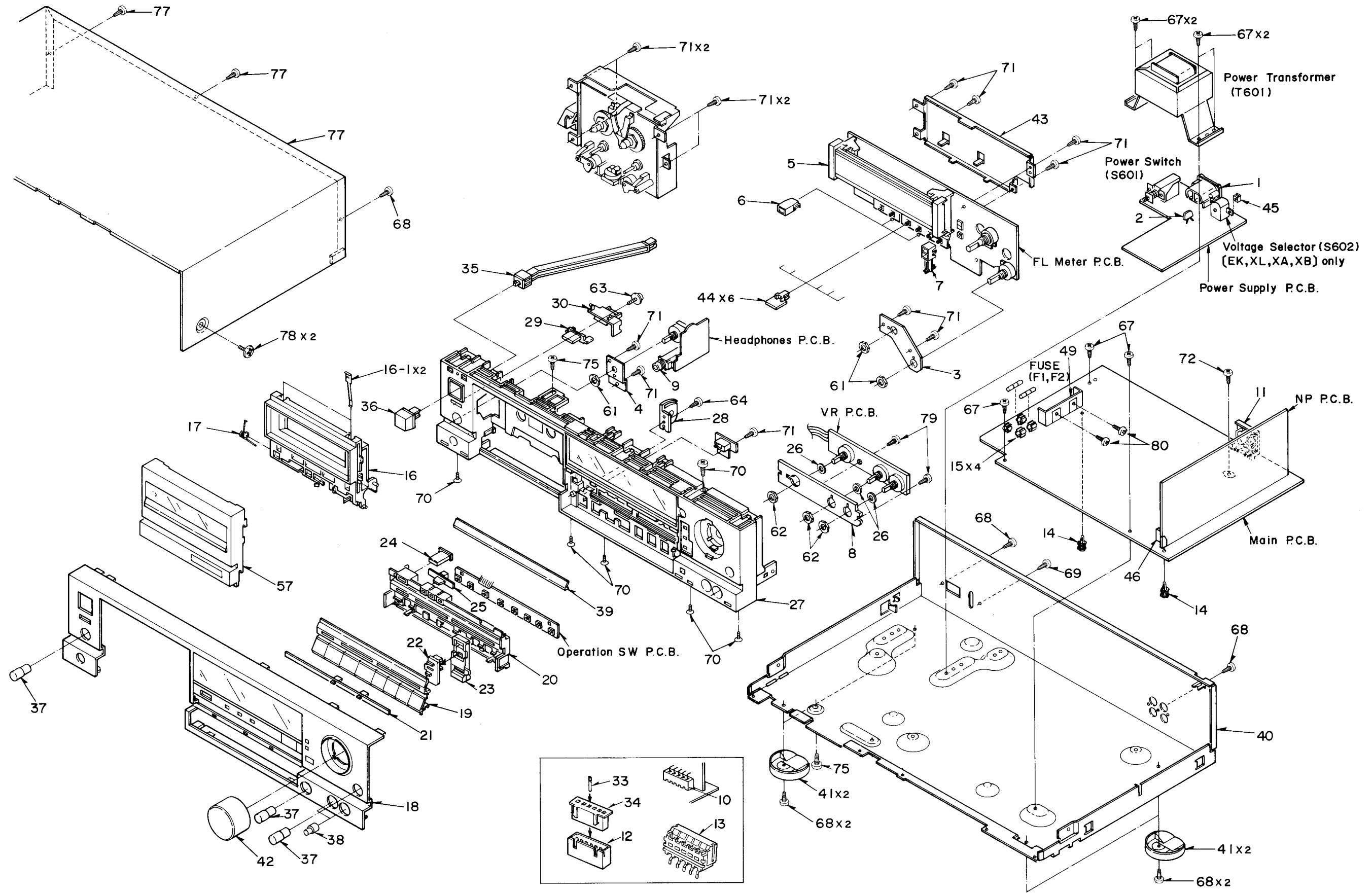

# SCHEMATIC DIAGRAM

(This schematic diagram may be modified at any time with the development of new technology.)

## Note:

- S601 : Power switch in "off" position.
- S602 : Voltage selector switch in "240V" position.  
(EK, XA, (110V — 127V — 220V — 240V) XB, XL)
- S701 : Stop switch in "off" position.
- S702 : Record switch in "off" position.
- S703 : Pause switch in "off" position.
- S704 : Record-muting switch in "off" position.
- S705 : Play switch in "off" position.
- S706 : Fast-forward mode switch in "off" position.
- S707 : Rewind switch in "off" position.
- S708 : Timer stand-by switch in "off" position.  
(rec — off — play)
- S709 : Counter reset switch in "off" position.
- S710 : Monitor switch in "off" position.
- S741 : Multiplex filter switch in "off" position.
- S742 : Repeat-play switch in "off" position.
- S752 : Noise-reduction DOLBY B mode switch in "off" position.
- S753 : Noise-reduction DOLBY C mode switch in "off" position.
- S754 : Noise-reduction dbx mode switch in "off" position.
- S901 : Metal/CrO<sub>2</sub> switch in "off (Metal)" position.
- S902 : Rec INH switch in "off" position.
- S903 : Pack switch in "off" position.
- S904 : 70μ/120μ selector switch in "off (70μs)" position.

• Resistance are in ohms (Ω), 1/4 watt unless specified otherwise.  
1K=1,000 (Ω), 1M=1,000k (Ω)

• Capacity are in micro-farads (μF) unless specified otherwise.

• All voltage values shown in circuitry are under no signal condition and playback mode with volume control at minimum position otherwise specified.

( ) ...Voltage values at record mode.

(—) indicates B (bias).

(→) indicates the flow of the playback signal.

(⇨) indicates the flow of the record signal.

## Important safety notice

Components identified by Δ mark have special characteristics important for safety. When replacing any of these components, use only manufacturer's specified parts.

## \* Caution!

IC and LSI are sensitive to static electricity.

Secondary trouble can be prevented by taking care during repair.

\* Cover the parts boxes made of plastics with aluminum foil.

\* Ground the soldering iron.

\* Put a conductive mat on the work table.

\* Do not touch the legs of IC or LSI with the fingers directly.

## SPECIFICATIONS \*Input level control...MAX

Playback S/N ratio *Test tape...QZZCFM	Greater than 45dB
Overall distortion *Test tape ...QZZCRA for Normal ...QZZCRX for CrO <sub>2</sub> ...QZZCRZ for Metal	Less than 4%
Overall S/N ratio *Test tape ...QZZCRA	Greater than 43dB (without NAB filter)

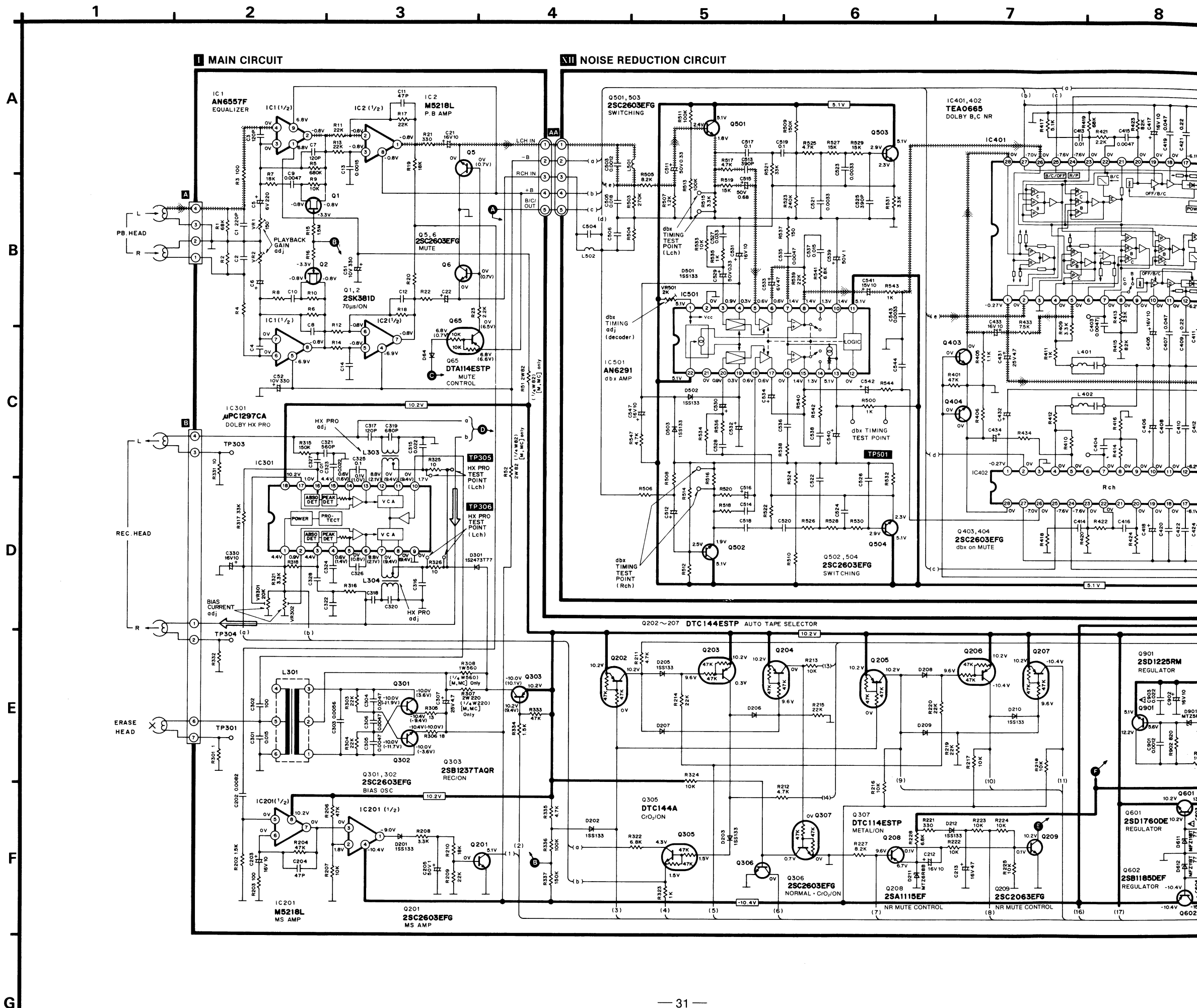

MAIN CIRCUIT

NOISE REDUCTION CIRCUIT

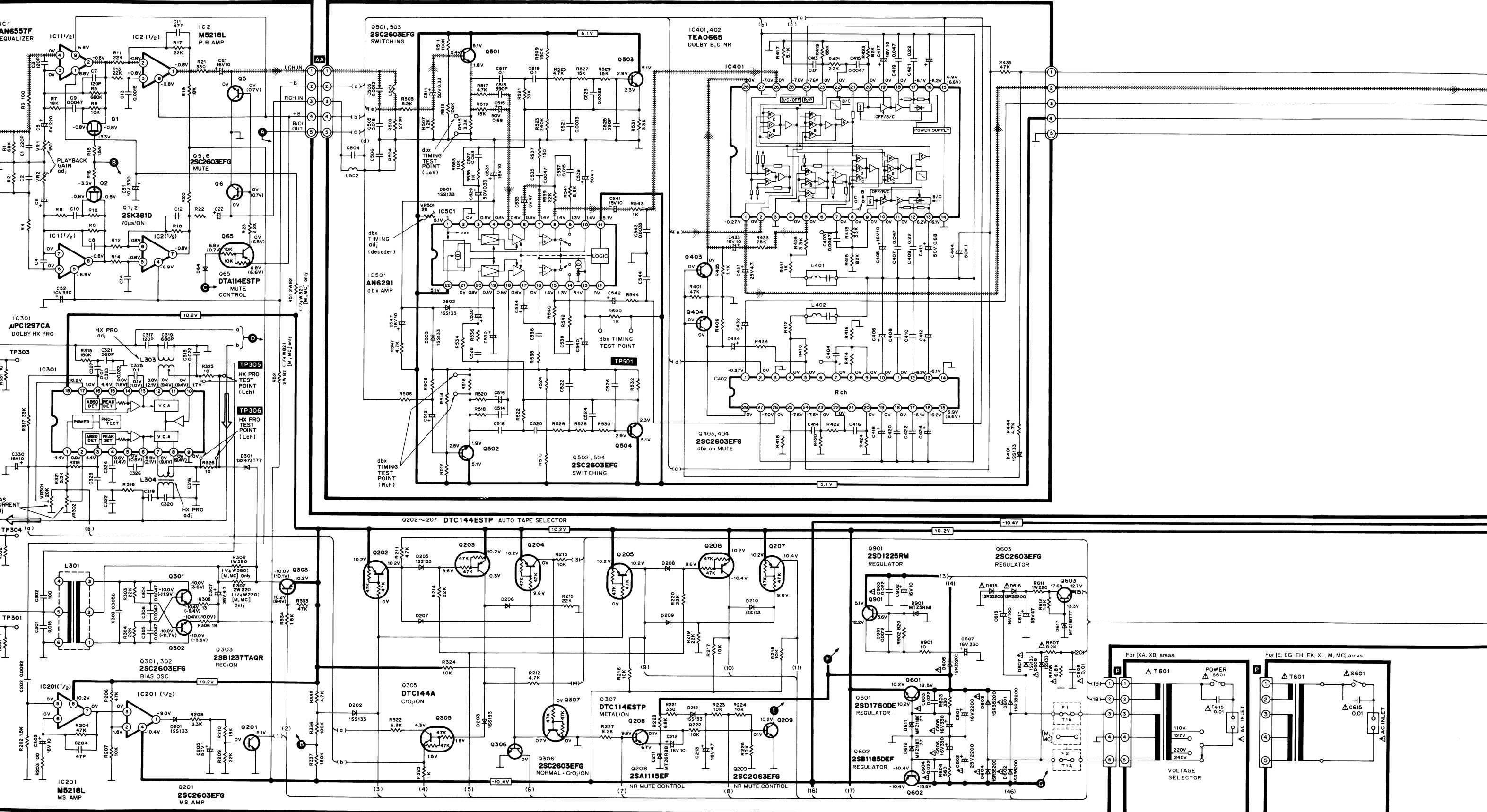

POWER SUPPLY CIRCUIT

III HEADPHONES CIRCUIT

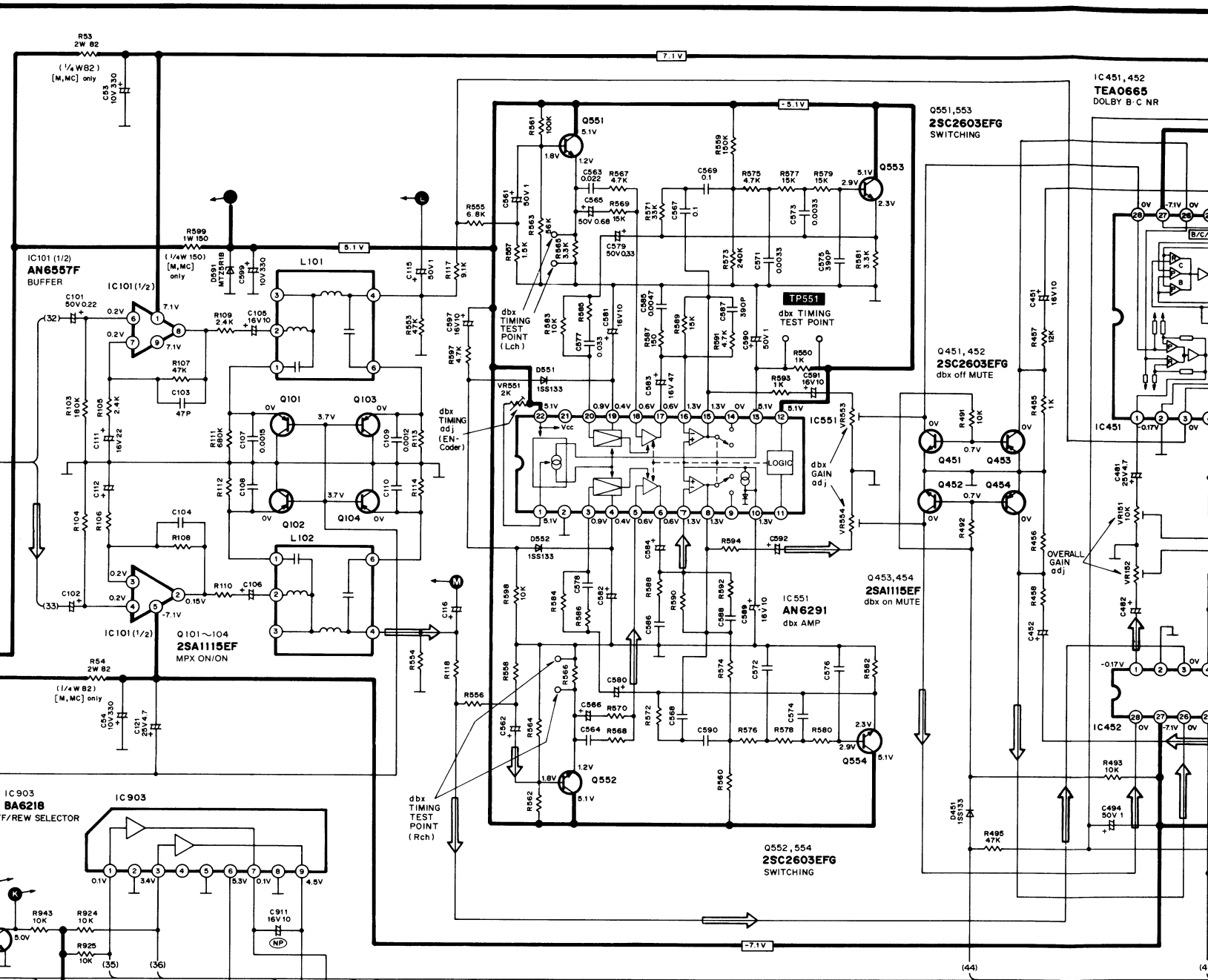
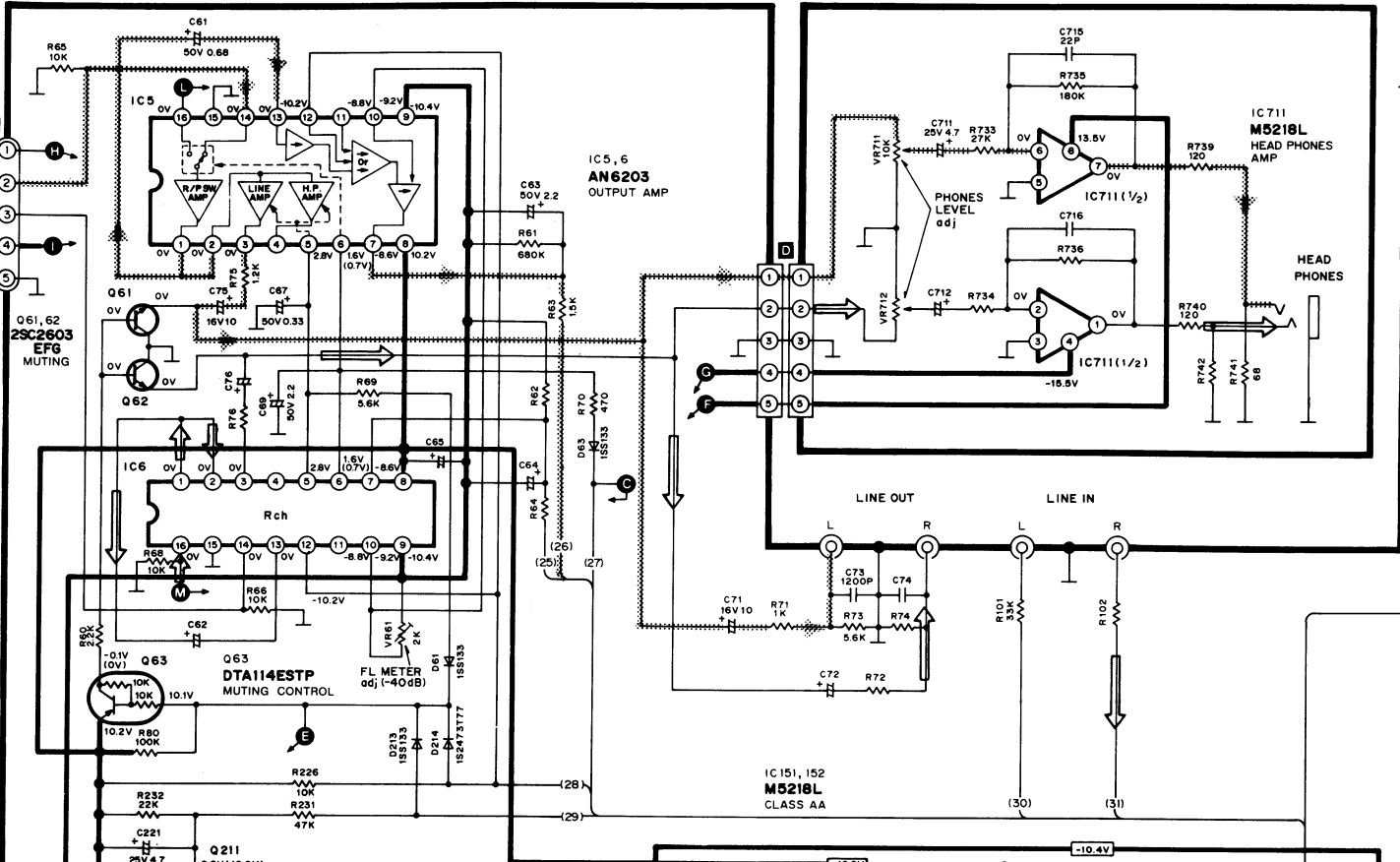

V BIAS ADJUST/ RECORDING CALIBRATION CONTROL CIRCUIT

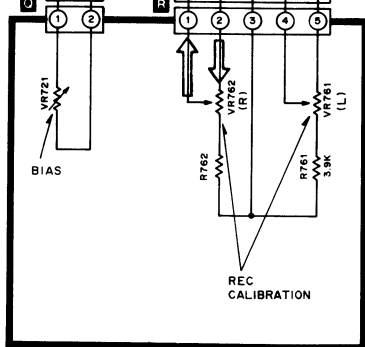

VI MECHANISM CIRCUIT

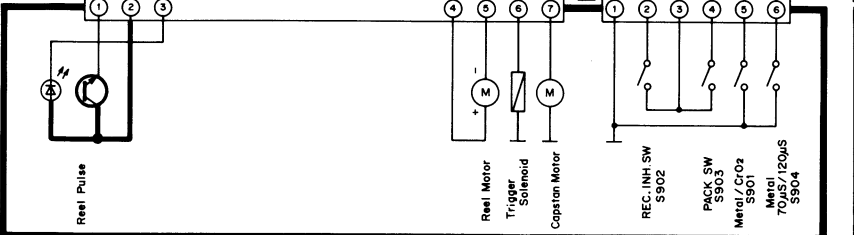

VII OPERATION SWITCH CIRCUIT

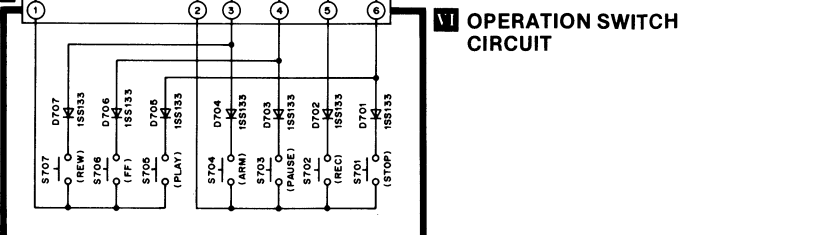

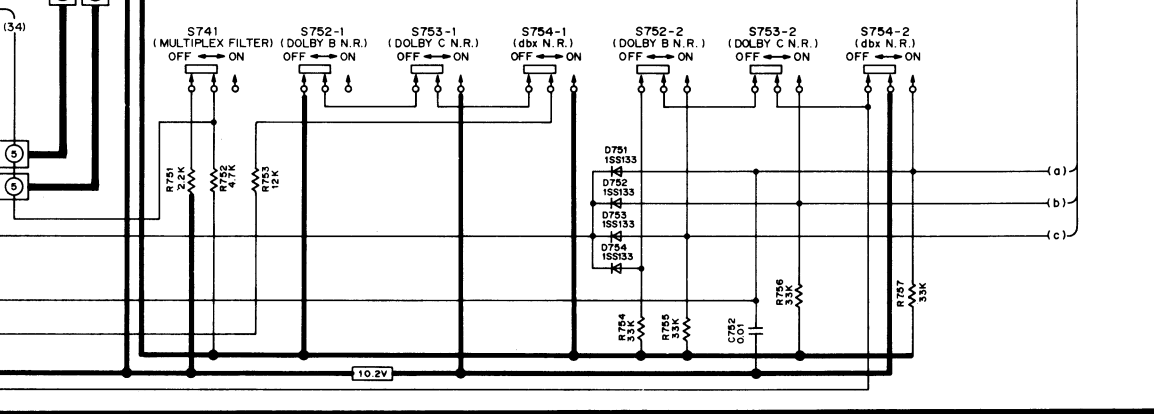
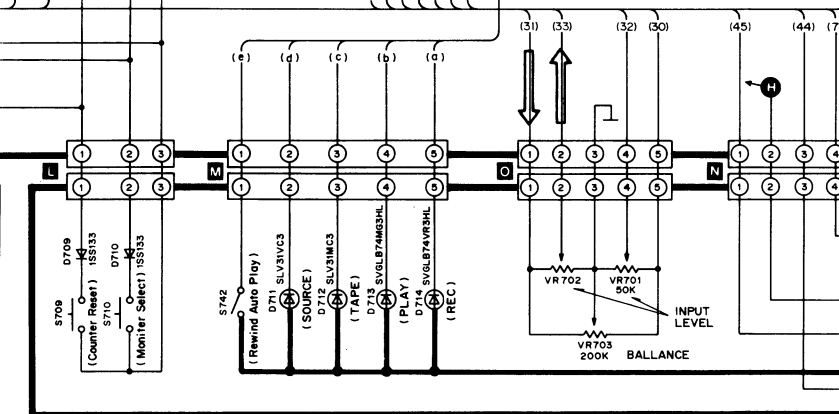
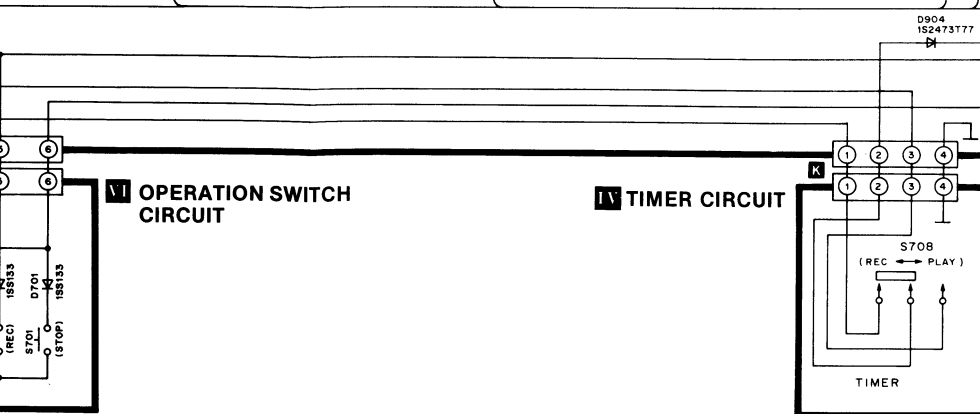
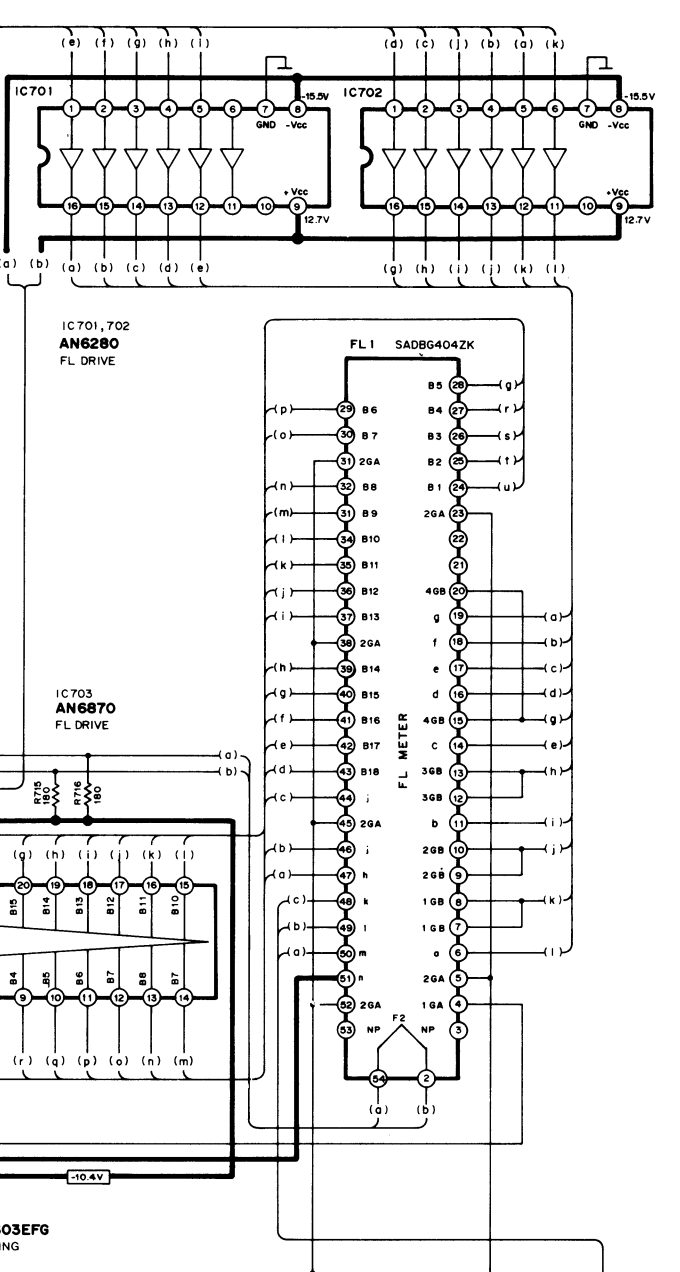
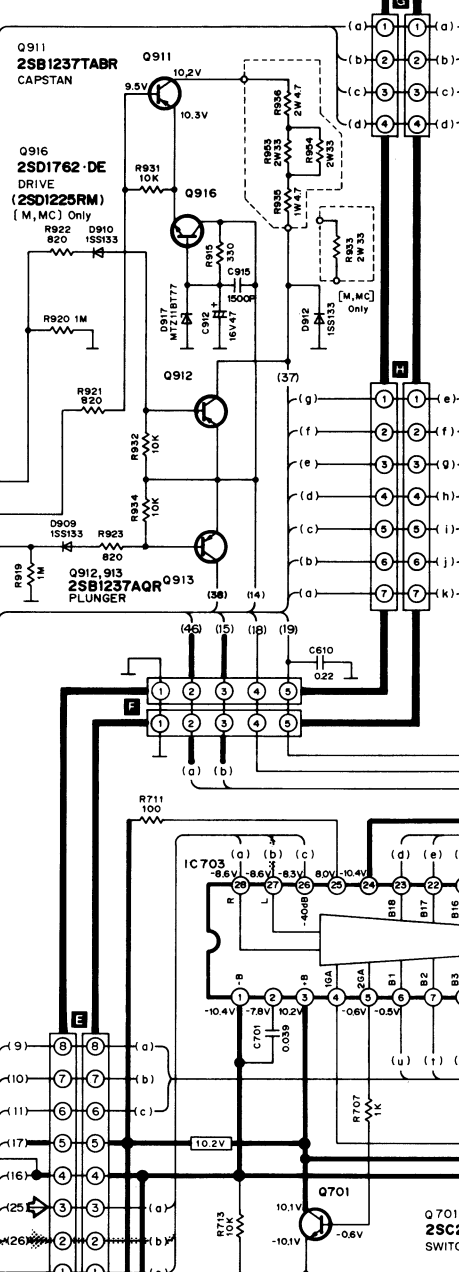
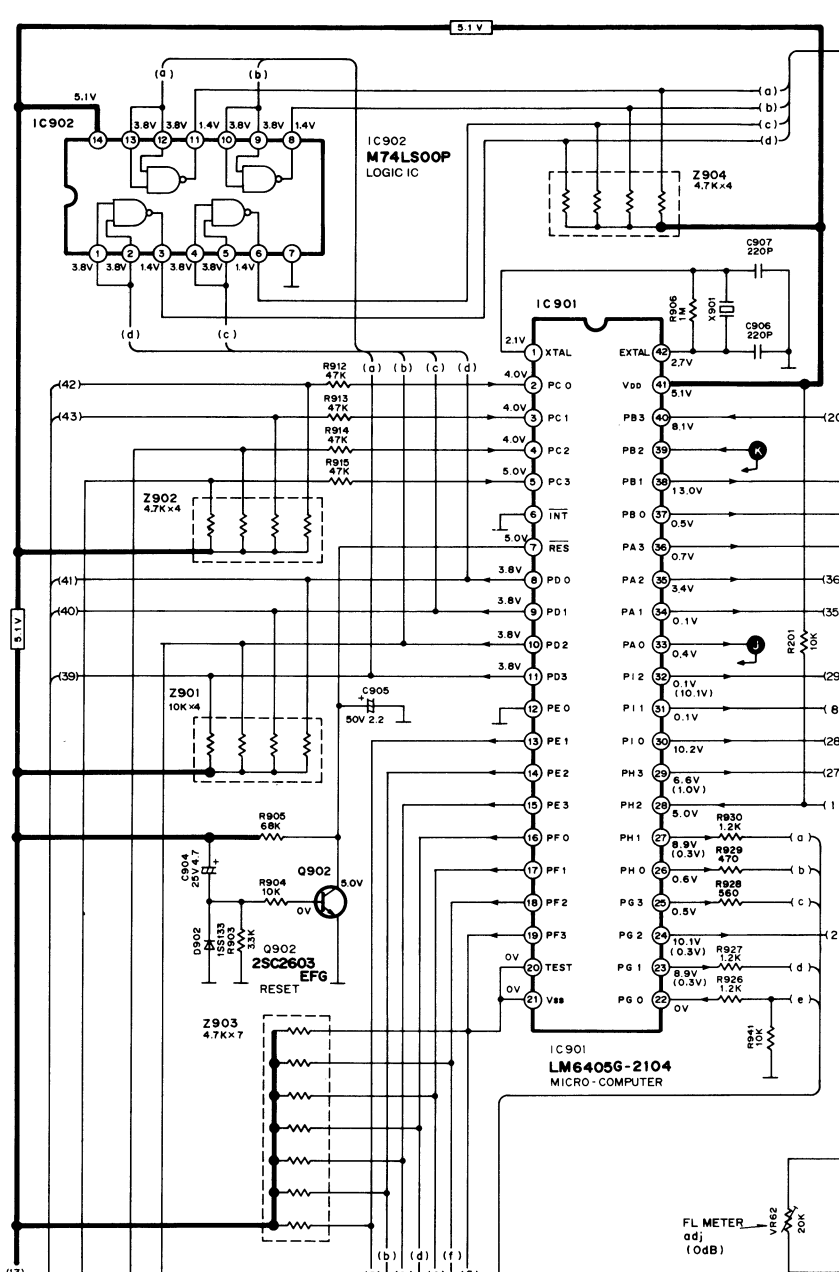
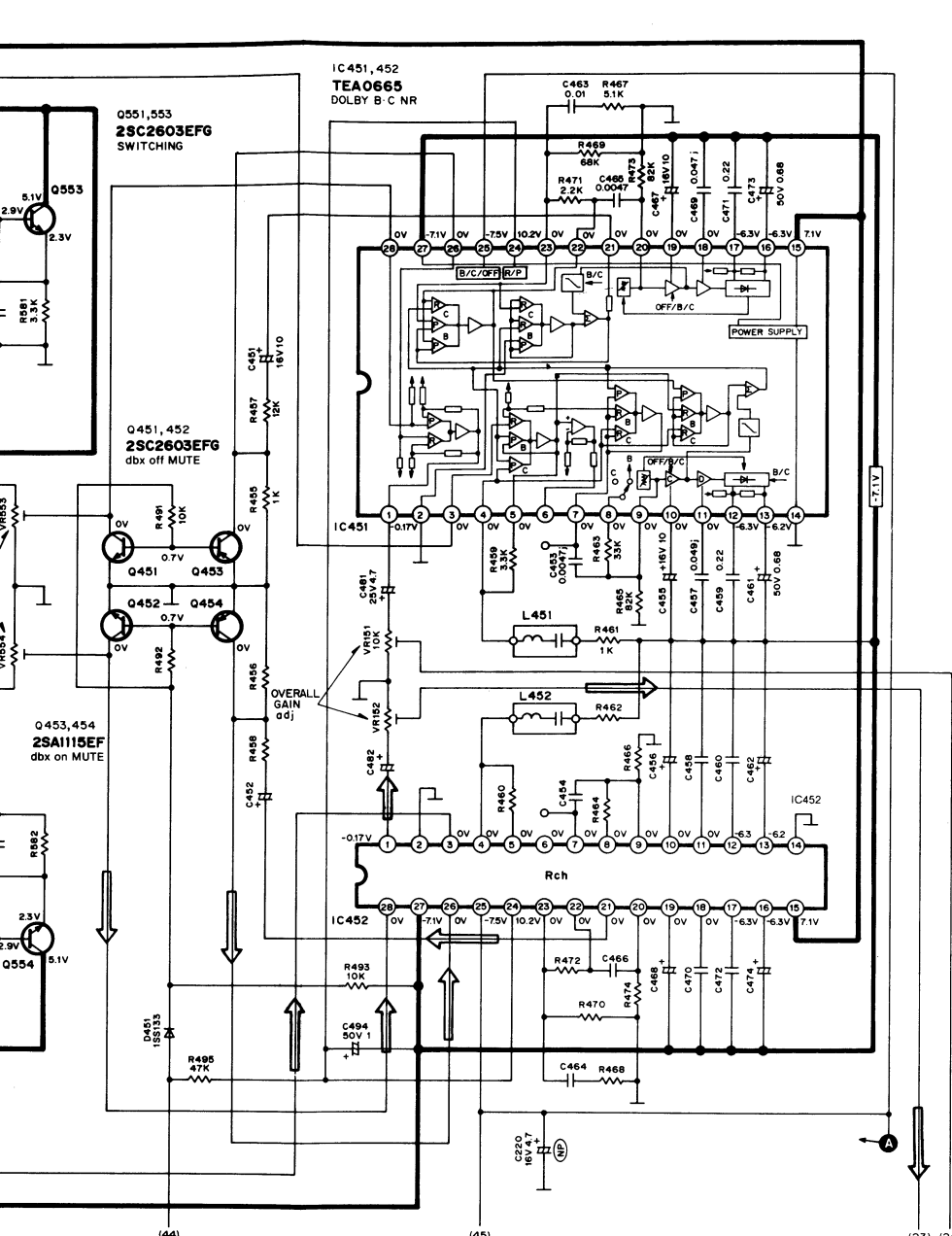

A  
B  
C  
D  
E  
F  
G

# REPLACEMENT PARTS LIST

Ref. No.	Part No.	Part Code	Description	Ref. No.	Part No.	Part Code	Description
CASSETTE DECK				140	SMQA1177	016 726 1013 3	AZIMUTH SPRING (L)
CASSETTE DECK				141	SMQA1207	016 740 0129 4	SPRING
101	SMQA1190	016 641 0261 3	TAPE GUIDE	142	SMQA1208	016 740 0128 5	ROLLER
102	SMQA1191	016 726 1019 7	SPRING	143	SMQA1210	016 717 0281 0	ARM
103	SJH104	001 270 1869 7	MAGNETIC HEAD	144	SMQA1211	016 726 1018 8	SPRING
104	SMQA1161	016 643 1069 7	WASHER	145	SMQA1069	016 718 3359 8	DET. LEVER
105	SMQA1192	001 270 1872 2	E.HEAD	146	SMQA1212	003 455 0413 6	PLUNGER CAP
106	SMQA1193	016 630 1863 0	SPACER	147	SMQA1213	016 756 0090 6	WHEEL
107	SMQA1194	016 630 1861 2	BASE	148	SMQA1215	016 726 1017 9	SPRING
108	SMQA1004	016 726 0826 8	SPRING	149	SMQA1218	016 754 0073 7	ANGULAR BELT
109	SMQA1005	016 740 0114 1	ROLLER	150	SMNM8A	016 632 1914 6	BRACKET
110	SMQA1006	016 726 0825 9	SPRING	151	SMNM16	016 632 1930 6	BRACKET
111	SMQA1196	016 630 1860 3	MECHANISM CHASSIS	152	SMQA1042	016 718 3369 6	LEVER
112	SMQA1199	016 717 0282 9	LEVER	153	SMQM30015A	016 718 3400 4	LEVER, EJECT
113	SMQA1012	016 726 0835 7	SPRING	155	QBT1936M	016 726 0914 9	SPRING
114	SMQA1200	016 765 0059 4	REEL TABLE	156	SUXM5	016 634 0141 1	SPACER
115	SMQA1015	016 718 3350 7	BRAKE LEVER	SCREWS, WASHERS & NUTS			
116	SMQA1061	016 742 0039 5	IDLER PULLEY	171	XSN2+4	005 500 1283 6	SCREW
117	SMQA1166	016 718 3407 7	DET. LEVER	172	SMQA1195	016 643 1074 0	WASHER
118	SMQA1170	016 726 1014 2	AZIMUTH SPRING (R)	173	SMQA1007	016 862 1041 8	WASHER
119	SMQA1021	016 643 0965 8	SPACER	174	SMQA1197	016 713 0424 3	SCREW
120	SMQA1041	001 035 0392 0	PHOTO ELECTRIC TRANSDUCER	175	SMQA1198	016 643 1073 1	WASHER
121	SMQA1022	016 643 0964 9	SPACER	176	SMQA1010	016 765 0056 7	WASHER
122	SJT30243-V	003 410 6222 6	CONNECTOR(2-P)	177	SMQA1014	016 641 0246 2	WASHER
122	SJT30440LX-V	003 410 6076 8	CONNECTOR(4-P)	178	SMQA1167	016 713 0418 1	SCREW
122	SJT30640LX-V	003 410 6149 8	CONNECTOR(6-P)	179	SMQA1168	016 713 0417 2	SCREW
122	SJT30740LX-V	003 410 5990 7	CONNECTOR(7-P)	180	XTN3+4	005 501 4864 4	SCREW
123	SMQA1172	016 726 1012 4	SPRING	181	SMQA1169	016 713 0419 0	SCREW
124	SMQA1024	016 726 0834 8	SPRING	182	XYN26+C3	005 503 0738 5	SCREW
125	SMQA1025	016 718 3349 0	DET. LEVER	183	XYN26+C6	005 503 0654 1	SCREW
126	SMQA1026	016 913 0003 6	REEL	184	XSN26+4	005 500 1357 5	SCREW
127	SMQA1052	016 726 0881 1	SPRING	185	SMQA1201	016 643 1072 2	WASHER
128	SMQA1171	016 717 0280 1	PLAY ARM	186	SMQA1175	016 713 0420 7	SCREW
129	SMQA1029	016 640 0459 6	CAP	187	XTN2+6	005 501 3949 4	SCREW
130	SMQA1070	003 454 0638 6	PLUNGER	188	XSN2+8	005 500 1301 1	SCREW
131	SMQA1202	016 756 0091 5	WHEEL	189	SMQA1207	016 740 0129 4	SPRING
132	SMQA1203	016 745 0261 6	CAM GEAR	190	SMQA1201	016 643 1072 2	WASHER
133	SMQA1097	016 643 1004 4	SPACER	191	SMQA1209	016 740 0127 6	NUT
134	SMQA1204	016 650 5410 7	BRACKET	192	SMQA1214	016 643 1071 3	WASHER
135	SMQA1036	002 310 2270 9	DC MOTOR	193	SMQA1216	016 713 0423 4	SCREW
136	SMQA1205	002 310 2587 1	DC MOTOR	194	SMQA1217	016 713 0422 5	SCREW
137	SMQA1206	016 754 0074 6	ANGULAR BELT	195	SMQA1219	016 713 0421 6	SCREW
138	SMQA1179	016 601 0647 3	SHIELD PLATE	196	XTN3+5F	005 501 3502 1	SCREW
139	SMQA1176	016 630 1859 6	HEAD PLATE	198	SMQA1017	005 500 6211 2	SCREW
				199	XTV3+6F	005 501 0891 7	SCREW

Ref. No.	Part No.	Part Code	Description	Ref. No.	Part No.	Part Code	Description
PACKINGS				(M, MC)			
P1	SPGM94		CARTON BOX	A2	△	SJA168-1	003 490 4122 9 POWER CORD
(MC, E, EG, EK)				[XA]			
(EH, XL)				A2	△	SJA173	003 490 4161 2 POWER CORD
P1	SPGM96		CARTON BOX	[XL]			
(M)				A2	△	SJA183	003 490 4873 7 POWER CORD
P1	SPGM98	016 971 5111 7	CARTON BOX	[XB]			
[XA, XB]				A3	△	SJP9215	003 402 1437 9 AC PLUG ADAPTOR
P2	SPSM17	016 977 3179 5	PAD	[XA, XB]			
P3	SPSM18	016 977 3178 6	PAD	A4		SQFM66	016 983 5310 6 INSTRUCTION MANUAL
P5	SPSM19	016 977 3189 3	PAD	(E, EK, EH, XL)			
P6	XZB40X60A02	016 978 0254 8	PROTECTION COVER	[XA]			
ACCESSORIES				A4		SQFM67	016 983 5308 0 INSTRUCTION MANUAL
A1	SJP2264	003 492 5035 3	OUTPUT CORD	(EG)			
A2	△	SFDAC05E03	003 490 4809 5 POWER CORD	A4		SQFM69	016 983 5309 9 INSTRUCTION MANUAL
(E, EG, EH)				(M)			
A2	△	SFDAC05G02	003 490 2613 3 POWER CORD	A4		SQFM70	016 983 5307 1 INSTRUCTION MANUAL
(EK)				(MC)			
A2	△	SJA166	003 490 4157 8 POWER CORD	A4		SQFM72	016 983 5311 5 INSTRUCTION MANUAL
				[XB]			



# MECHANICAL PARTS LOCATION

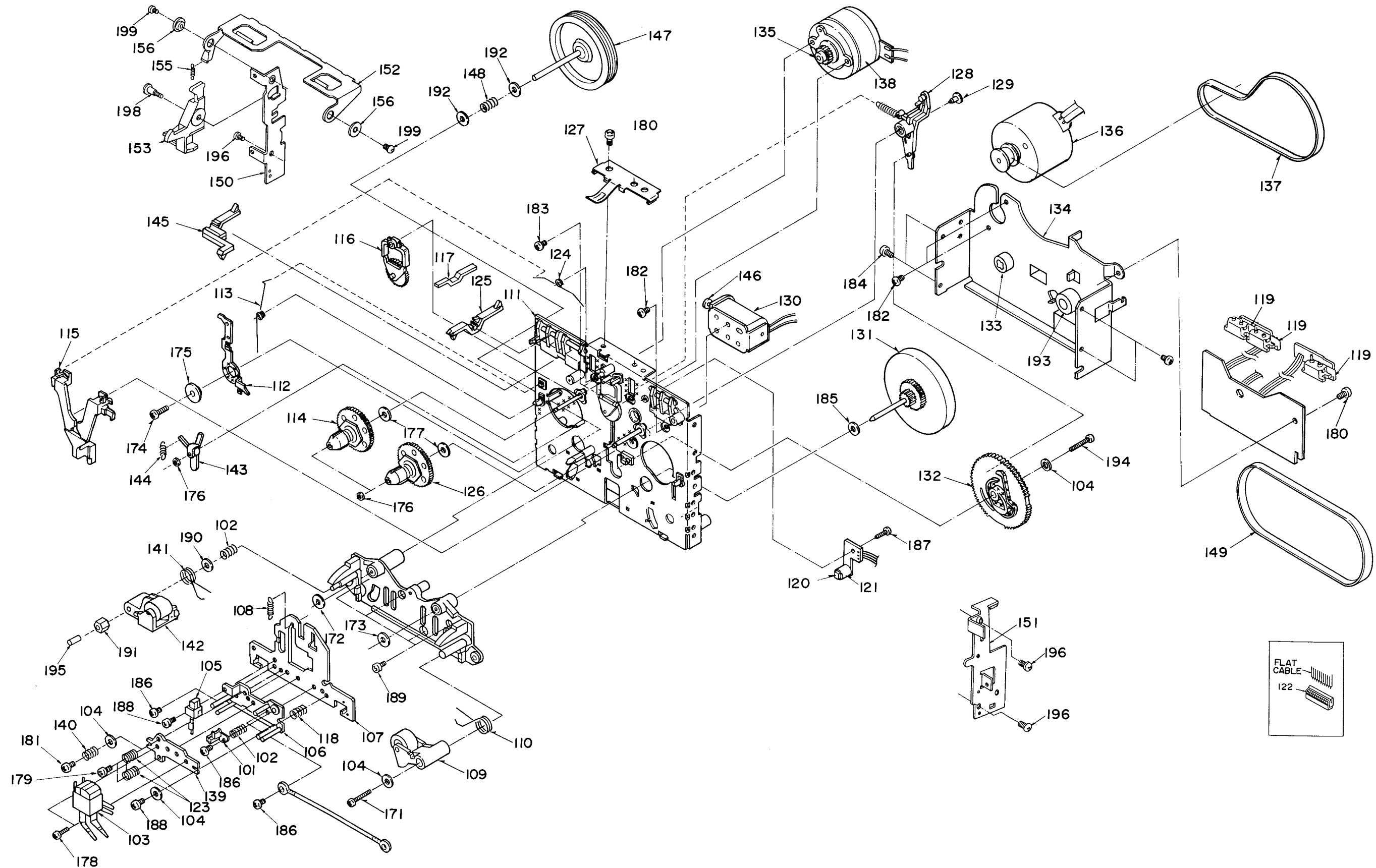

# DESCRIPTION OF FL PANEL

## • COMMON

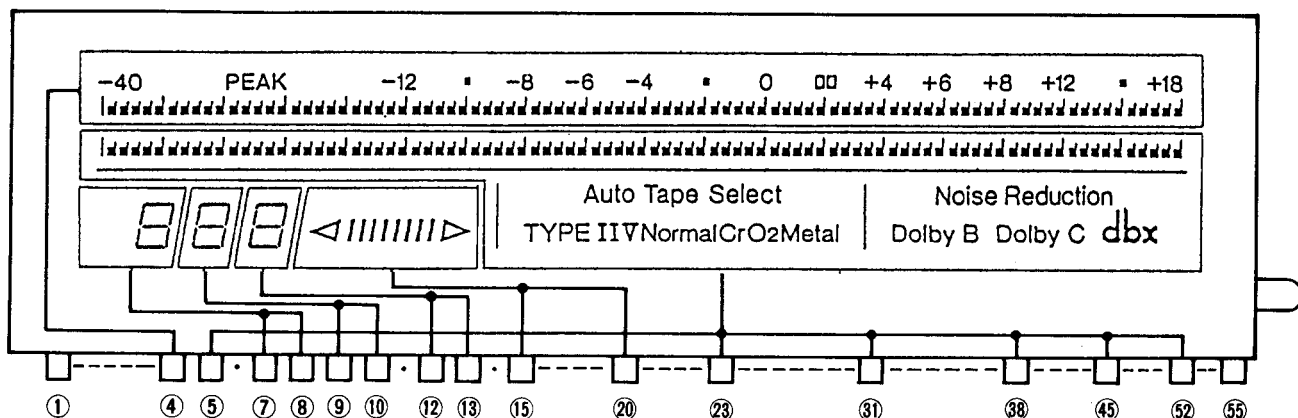

## • SEGMENT

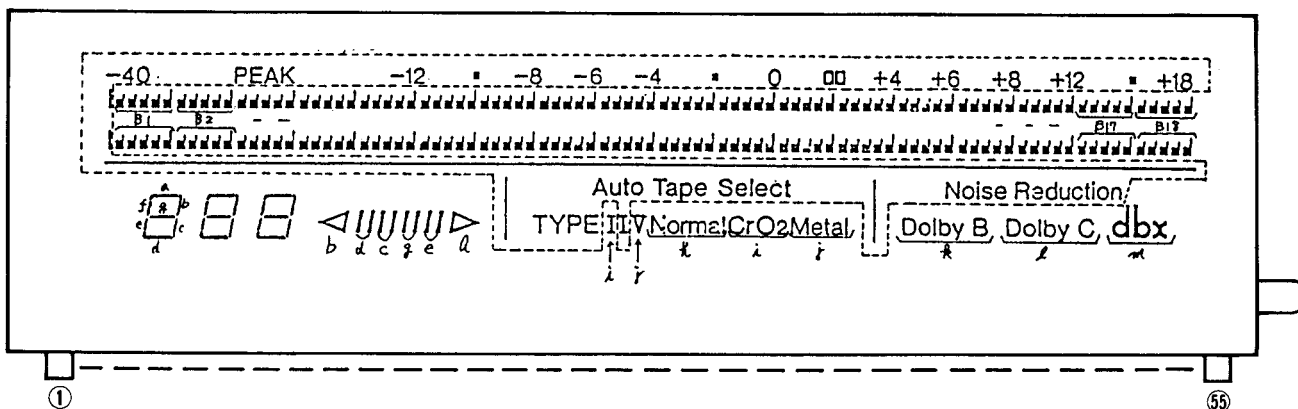

## • PIN CONNECTION

PIN NO.	1	2	3	4	5	6	7	8	9	10	11	12	13	14	15	16	17	18	19	20	21	22	23	24	25	26	27	28
CONNECTION	F	F	NP	1G	2G	a	1G	1G	2G	2G	b	3G	3G	c	4G	d	e	f	g	4G	NP	NP	2G	B	B	B	B	B
	1	1		A	A		B	B	B	B		B	B		B					B			A	1	2	3	4	5

PIN NO.	29	30	31	32	33	34	35	36	37	38	39	40	41	42	43	44	45	46	47	48	49	50	51	52	53	54	55
CONNECTION	B	B	2G	B	B	B	B	B	B	2G	B	B	B	B	B	j	2G	i	h	k	l	m	n	2G	NP	F	F
	6	7	A	8	9	10	11	12	13	A	14	15	16	17	18		A						A		2	2	

# dbx/ Closed Loop Dual Capstan DOUBLE DOLBY SYSTEM

## DEUTSCH

Verwenden Sie bitte diese Broschüre Zusammen  
mit der Service-Anleitung für das Modell Nr.  
RS-B905

### ■ MESSUNGEN UND EINSTELL METHODEN

#### Meßinstrumente

- Elektronisches Voltmeter(EVM)
- Oszilloskop
- Digitaler Frequenzmesser
- Audiofrequenz-Oszillator
- Dämpfungswiderstand
- Gleichstrom-Voltmeter
- Widerstand (600Ω)

#### Tonkopf-Azimuteinstellung

1. Spielen Sie auf dem Testband (QZZCFM) den Teil für die Azimuteinstellung (8 kHz, -20dB) ab. Drehen Sie die Azimuteinstellschraube so lange, bis die Abgaben des L-K und R-K den Höchstwert erreichen, und die Lissajoscghe wellenfigur sich, wie abgebildet, 0 Grad nähert.

#### Anmerkung:

When L-K und R-K nicht auf demselben Punkt ihren Höchstwert erreichen, stellen Sie beide Kanäle auf den jeweiligen Höchstwert und gleichen dann aus.

2. Nehmen Sie denselben Einstellvorgang in der Wiedergabestelle vor.



Abb. 1



Abb. 2

#### Bandgeschwindigkeitseinstellung

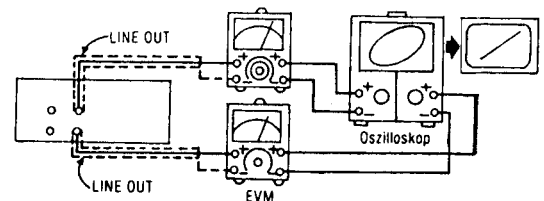
1. Spielen Sie den Mittelteil des Testbands (QZZCWAT) ab.
2. Stellen Sie den VR im Motor (Siehe Abb. 3) so ein, daß die Abgabe den Normwert erfüllt.

Normwert: 3000 + 15, -10Hz

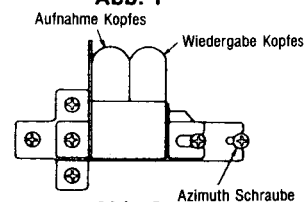

Abb. 3

#### Einstellung der Wiedergabeverstärkungsregelung

1. Spielen Sie auf dem Testband (QZZCFM) den Teil für die Einstellung der Verstärkungsregelung (315 Hz, 0 dB) ab.
2. Stellen Sie VR1 (L-K) und VR2 (R-K) so ein, daß die Abgabe den Normwert erfüllt.

Normwert: 0.4V ± 0.5dB

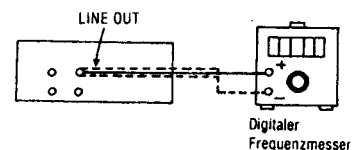

Abb. 4

## Wiedergabefrequenzaang

1. Spielen Sie auf dem Testband (QZZCFM) den Teil für den Frequenzgang (315 Hz, 12,5 kHz ~ 63 Hz, -20 dB) ab.
2. Achten Sie darauf, daß der Frequenzgang für beide Kanäle (L-K, R-K) in dem in **Abb. 6** gezeigten Bereich liegt.

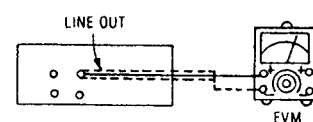

Abb. 5



Abb. 6

## Fluoreszenzanzeigeneinstellung

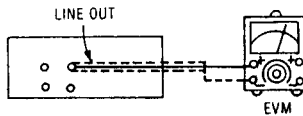
1. Legen Sie das normale Leertestband (QZZCRA) ein und geben bei Aufnahme-/Pause-Betrieb ein Bezugsingabesignal (1 kHz, -24 dB) ein.
2. Verwenden Sie einen Lautstärkereglern und stellen Sie diesen so ein, daß an den "LINE OUT"-Anschlüssen des Kassettendecks 0.4 V anliegen.

### -40 dB Einstellung

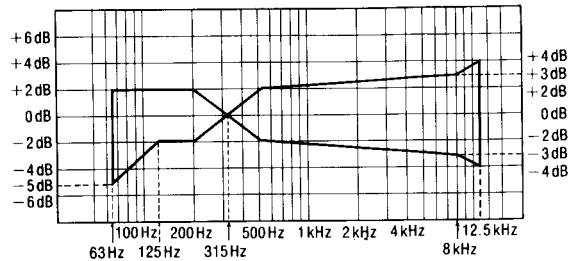
3. Stellen Sie den Pegel des Signaleingabepiegel aus Schritt 1 auf 40 dB und geben das Signal ins Gerät ein.
4. Justieren Sie **VR61** so, daß der "-40 dB"-Abschnitt der Anzeige schwach aufleuchtet.

### 0 dB Einstellung

5. Stellen Sie den Pegel des Eingabesignals wie in Schritt 2 oben beschrieben ein.
6. Justieren Sie **VR62** so, daß der "-0 dB"-Abschnitt der Anzeige schwach aufleuchtet.
7. Wiederholen Sie die Schritte 1 ~ 6 und achten darauf, daß der -40 dB und 0 dB Anzeigenabschnitt schwach aufleuchten.



Abb. 7

## Gesamtfrequenzgang

1. Legen Sie das normale Leertestband (QZZCRA) ein und stellen das Gerät auf Aufnahme-/Pause-Betrieb.
2. Geben Sie über einen Lautstärkereglern ein Bezugsingabesignal (1 kHz, -24 dB) ein.
3. Stellen Sie das Signal auf 20 dB und justieren die Frequenz von 50 Hz ~ 15 kHz.
4. Nehmen Sie das Wobbelsignal auf.
5. Geben Sie das aufgenommene Signal wieder und achten darauf, daß dieses sich im Vergleich zur Bezugsfrequenz (1 kHz) in dem in **Abb. 9** aufgezeichneten Bereich befindet.
6. Sollte das Signal nicht im Normbereich liegen, justieren Sie **VR301** (L-K) und **VR302** (R-K) so, daß der Frequenzpegel mit der Norm übereinstimmt.
  - Nach oben im Hochfrequenzbereich ausgleichen... Den vormagnetisierungsstrom anheben.
  - Nach unten im Hochfrequenzbereich ausgleichen... Den vormagnetisierungsstrom senken.
7. Wiederholen Sie die Schritte 2 ~ 6 und verwenden das CrO<sub>2</sub> Band (QZZCRX) und das Metallband (QZZCRZ). Der Frequenzbereich wird auf 16 kHz (50 Hz ~ 16 kHz) angehoben.
8. Achten Sie darauf, daß sich der Frequenzpegel in dem in **Abb. 10** aufgezeigten Bereich befindet.



Abb. 8



Abb. 9

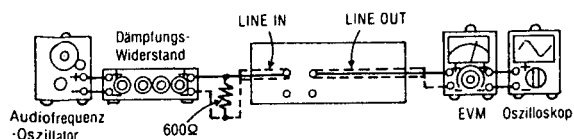

Abb. 10

### Einstellung der Gesamtverstärkungsregelung

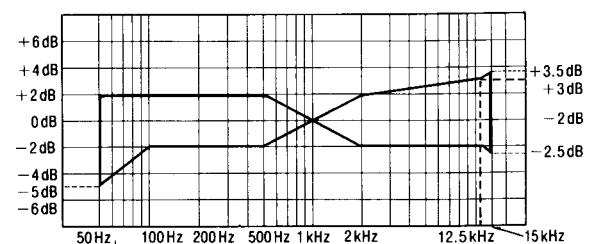
1. Legen Sie das normale Leertestband (QZZCRA) ein und stellen das Gerät auf Aufnahme-/Betrieb.
2. Legen Sie ein Bezugseingabesignal (1 kHz, -24 dB) an. Stellen Sie das Ausgangssignal auf einen Pegel von 0.4 V ein.
3. Nehmen Sie das Eingabesignal auf.
4. Geben Sie das in Schritt 3 oben aufgenommene Signal wieder und achten Sie darauf, daß das Ausgangssignal mit dem Normwert übereinstimmt.
5. Sollte der Wert nicht innerhalb der Norm liegen, justieren Sie **VR151** (L-K) und **VR152** (R-K).
6. Wiederholen Sie die Schritte 2 ~ 5 von oben so lange, bis das Ausgangssignal im Normbereich liegt.

Normwert: 0.4V ± 0.5dB

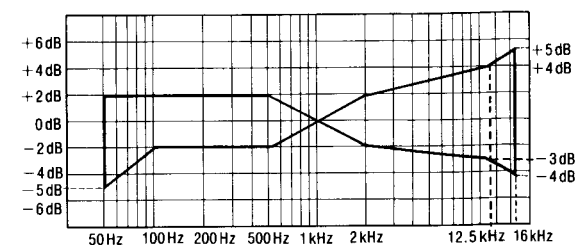

Abb. 11

### HX-PRO Einstellung

1. Legen Sie das Metalleertestband (QZZCRZ) ein und stellen das Gerät auf Aufnahme-/Pause-Betrieb.
2. Schalten Sie ein Gleichspannungsvoltmeter parallel zu **R325** (L-K, 10Ω) und **R326** (R-K, 10Ω).
3. Stellen Sie **L303** (L-K) und **L304** (R-K) so ein, daß die Spannung < 110 mV Gleichspannung beträgt.

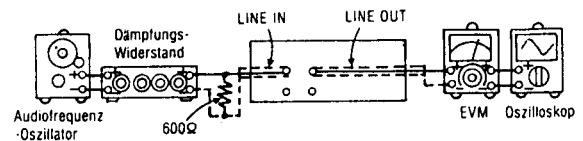

Abb. 12

TPA { TP305 (L-CH)  
TP306 (R-CH) } TPB { R325 (L-CH)  
R326 (R-CH) }

### dbx Synchronisierung

#### Kompressionsseite

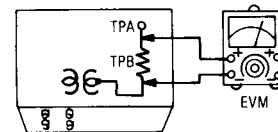
1. Stellen Sie den Rauschunterdrückungswählschalter in die dbx Stellung.
2. Legen Sie ein 1 kHz Signal an die "LINE IN"-Anschlüsse durch einen Lautstärkereglер.
3. Schalten Sie ein Wechselspannungsvoltmeter parallel zu **R565** (L-K) und **R566** (R-K). Justieren Sie den Eingabesignalpegel so, daß die Spannung 20 mV beträgt.
4. Schalten Sie ein Gleichspannungsvoltmeter parallel zu **R550** (TP551) und justieren **VR551** so, daß die Spannung 15 mV beträgt.

#### Expansionsseite

5. Wiederholen Sie Schritt 1 und 2.
6. Schalten Sie ein Wechselspannungsvoltmeter parallel zu **R515** (L-K) und **R516** (R-K). Justieren Sie den Eingabesignalpegel so, daß Spannung 20 mV beträgt.
7. Schalten Sie ein Gleichspannungsvoltmeter parallel zu **R500** (TP501) und justieren **VR501** so, daß die Spannung 15 mV beträgt.



Abb. 13

TPA { TP551 (ENCODE)  
TP501 (DECODE) }

TPB { R550 (ENCODE)  
R500 (DECODE) }

### Einstellung der dbx Verstärkungsregelung

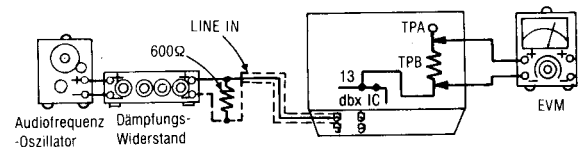
1. Legen Sie das normale Leertestband (QZZCRA) ein und stellen das Gerät auf Aufnahme-Betrieb.
2. Legen Sie ein 1 kHz Signal an die "LINE IN"-Anschlüsse durch einen Lautstärkereglер.
3. Justieren Sie den Eingabepegel so, daß die Anzeige 0 dB anzeigt.
4. Schließen Sie ein Wechselspannungsvoltmeter an den "LINE OUT"-Anschlußbe..
5. Schalten Sie den Monitorbetriebsartschalter von "TAPE" auf "SOURCE". Justieren Sie **VR553** (L-K) und **VR553** (R-K) so, daß die Spannungsdifferenz am "LINE OUT"-Anschluß  $\cong 0.5$  dB ausmacht.



Abb. 14

# FRANÇAIS

Ceci est à utiliser conjointement avec manuel d'entretien du modèle No. RS-B905

## METHODES DES MEASURES ET REGLAGES

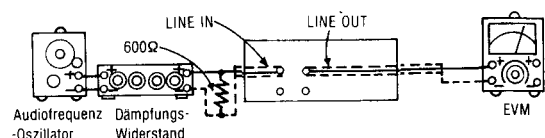
### Appareils de mesure

- Voltmètre électronique
- Oscilloscope
- Compteur de fréquence numérique
- Oscillateur de fréquence audio
- A.T.T.(Atténuateur)
- Voltmètre à C.C.
- Résistance (600Ω)

### Reglage Azimutal de la tete

1. Faire jouer la portion du réglage de l'azimut (8 kHz, -20 dB) de la bande d'essai (QZZCFM). Ajuster la vis de la mise au point azimutale jusqu'à ce que les sorties du canal de gauche et du canal de droite soient maximisées et que la forme d'onde de Lissajous, comme il est illustré, approche de 0 degré.

Nota:

- Si le canal de gauche et canal de droite ne sont pas maximisés au même point, régler le point où les niveaux de chaque canal sont maximisés et égaux.
2. Effectuer le même réglage sur le mode d'audition.

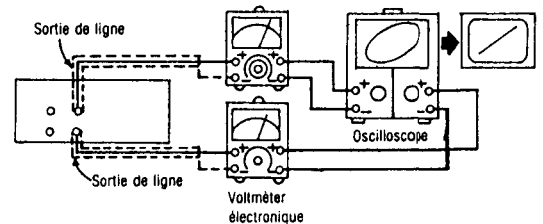

Fig. 1

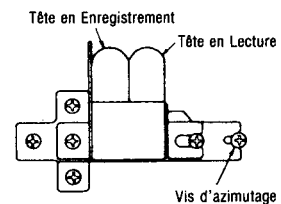

Fig. 2

### Reglage de la Vitesse de Defilement

1. Faire jouer la portion médiane de la bande d'essai (QZZCWAT).
2. Régler le régulateur de tension dans le moteur (voir Fig. 3), de telle sorte que la sortie soit en deçà de la valeur standard.

Valeur standard: 3000 + 15, -10Hz

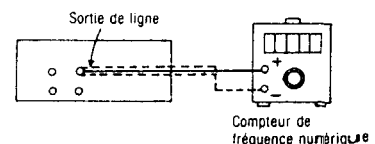

Fig. 3

### Reglage de L'amplification de Lecture

1. Faire jouer la partie réglée de l'amplification (315 Hz, 0 dB) de la bande d'essai (QZZCFM).
2. Régler VR1 (canal de gauche) et VR2 (canal de droite) de telle sorte que la sortie soit en deçà de la valeur standard.

Valeur standard: 0.4V ± 0.5dB

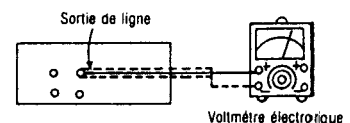

Fig. 4

### Reponse en Frequence de la Lecture

1. Faire jouer la partie de la réponse en fréquence (315 Hz, 12.5 kHz, -63 Hz, -20 dB) de la bande d'essai (QZZCFM).
2. S'assurer que la réponse en fréquence soit en deçà de la plage montrée dans la Fig. 6, à la fois pour le canal de gauche et le canal de droite.

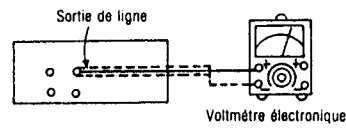

Fig. 5

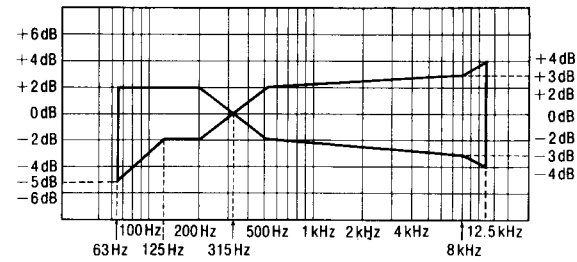

Fig. 6

### Reglage du Mesureur Fluorescent

1. Introduire la bande d'essai vierge normale (QZZCRA) et appliquer un signal d'entrée de référence (1 kHz, -24 dB) sur le mode d'intermission d'un disque.
2. En utilisant un atténuateur, le régler jusqu'à ce que la tension des bornes "LINE OUT" (sortie de ligne) des platines de magnétophones soit de 0.4 V.

#### Reglage de -40 dB

3. Diminuer le niveau du signal d'entrée de l'étape 1 de 40 dB et l'appliquer à l'appareil.
4. Régler VR61 de telle sorte que le segment de "-40 dB" soit légèrement éclairé.

#### Reglage de 0 dB

5. Régler le niveau du signal d'entrée comme il est indiqué à l'étape 2 ci-dessus.
6. Ajuster VR62 de telle sorte que le segment "0 dB" soit légèrement éclairé.
7. Répéter les étapes 1 ~ 6 ci-dessus et s'assurer que les segments à la fois de -40 dB et de 0 dB s'éclairissent légèrement.

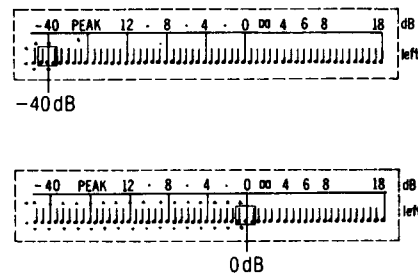

Fig. 7

### Reponse en Frequence Totale

1. Introduire la bande d'essai vierge normale (QZZCRA) et régler l'appareil sur le mode d'intermission d'un disque.
2. Appliquer un signal d'entrée de référence (1 kHz, -24 dB) par l'intermédiaire d'un atténuateur.
3. Diminuer le signal de 20 dB et régler la fréquence de 50 Hz ~ 15 kHz.
4. Enregistrer le balayage de fréquence.
5. Faire jouer le signal enregistré et s'assurer qu'il soit en deçà de la plage montrée à la Fig. 9 en comparaison à la fréquence de référence (1 kHz).
6. S'il n'est pas en deçà de la plage standard, régler VR301 (canal de gauche) et VR302 (canal de droite) de telle sorte que le niveau de fréquence soit en deçà de la plage standard.
  - Elévation du niveau dans la plage de fréquence élevée..... Augmente le courant de polarisation.
  - Diminution du niveau dans la plage de fréquence élevée..... Diminue le courant de polarisation.
7. Répéter les étapes 2 ~ 6 ci-dessus en utilisant la bande CrO<sub>2</sub> (QZZCRX) et la bande métallisée (QZZCRX) en augmentant la plage de fréquence à 16 kHz (50 Hz ~ 16 kHz).
8. S'assurer que le niveau soit en deçà de la plage montrée à la Fig. 10.

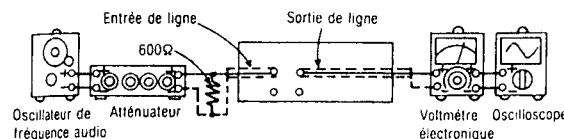

Fig. 8

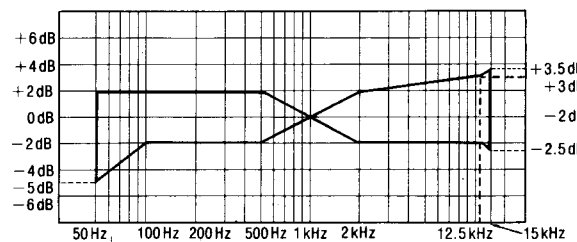

Fig. 9

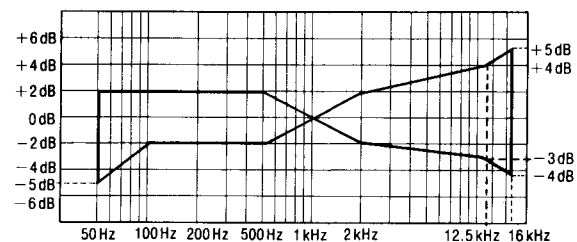

Fig. 10

### Reglage de L'amplification Totale

1. Introduire la bande d'essai vierge normale (QZZCRA) et régler l'appareil sur le mode d'intermission d'un disque.
2. Appliquer un signal d'entrée de référence (1 kHz, -24 dB). Diminuer la sortie de telle sorte que son niveau devienne de 0.4 V.
3. Enregistrer ce signal d'entrée.
4. Faire jouer le signal enregistré à l'étape 3 ci-dessus, et s'assurer que la sortie en deçà de la valeur standard.
5. Si elle n'est pas en deçà de la valeur standard, régler VR151 (canal de gauche) et VR152 (canal de droite).
6. Répéter les étapes 2 ~ 5 ci-dessus jusqu'à ce que la sortie soit en deçà de la valeur standard.

Valeur standard: 0.4V ± 0.5dB

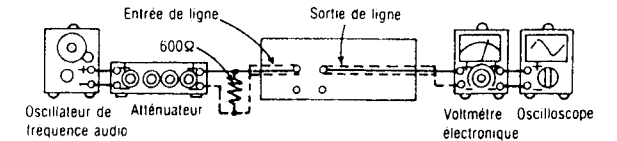

Fig. 11

### Reglage de HX-PRO

1. Introduire la bande vierge métallisée (QZZCRZ) et régler l'appareil sur le mode d'intermission d'un disque.
2. Raccorder un voltmètre à C.C. à travers R325 (canal de gauche, 10 ohms) et R326 (canal de droite, 10 ohms).
3. Régler L303 (canal de gauche) et L304 (canal de droite) de telle sorte que la tension soit inférieure à 110 mV C.C.

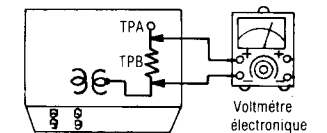

Fig. 12

TPA { TP305 (L-CH)  
TP306 (R-CH) } TPB { R325 (L-CH)  
R326 (R-CH) }

### Reglage de la Synchronisation de dbx

#### Cote du Codage

1. Régler le commutateur de réduction des bruits sur la position "dbx".
2. Appliquer un signal de 1 kHz aux bornes "LINE IN" (entrée de ligne) par l'intermédiaire d'un atténuateur.
3. Brancher un voltmètre à C.A. à travers R565 (canal de gauche) et R566 (canal de droite). Ajuster le niveau du signal d'entrée de telle sorte que la tension soit de 20 mV.
4. Brancher un voltmètre à C.C. à travers R550 (TP551) et ajuster VR551 de telle sorte que la tension soit de 15 mV.

#### Cote du Decodage

5. Répéter les étapes 1 et 2 ci-dessus.
6. Brancher un voltmètre à C.A. à travers R515 (canal de gauche) et R516 (canal de droite). Ajuster le niveau du signal d'entrée de telle sorte que la tension soit de 20 mV.
7. Brancher un voltmètre à C.C. à travers R500 (TP501) et ajuster VR501 de telle sorte que la tension devienne de 15 mV.

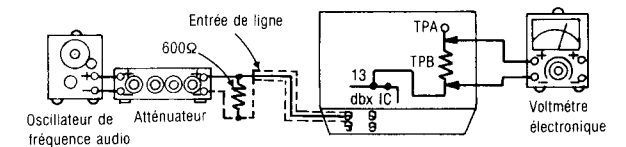

Fig. 13

TPA { TP551 (ENCODE)  
TP501 (DECODE) }  
TPB { R550 (ENCODE)  
R500 (DECODE) }

### Reglage de L'amplification de dbx

1. Introduire la bande d'essai vierge normale (QZZCRA) et régler l'appareil sur le mode d'enregistrement.
2. Appliquer un signal de 1 kHz à "LINE IN" (entrée de ligne) par l'intermédiaire d'un atténuateur.
3. Ajuster le niveau d'entrée de telle sorte que la lecture du mesureur soit de 0 dB.
4. Brancher un voltmètre à C.A. à la borne "LINE OUT" (sortie de ligne).
5. Commuter la position du commutateur de contrôle entre "TAPE" et "SOURCE". Ajuster VR553 (canal de gauche) et VR554 (canal de droite) de telle sorte que la différence de tension à "LINE OUT" (sortie de ligne) soit en deçà de 0.5 dB.

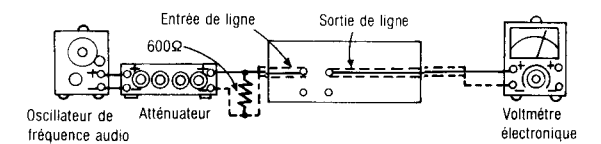

Fig. 14

# ESPAÑOL

Sírvase utilizarse junto con manual de servicio para el model No. RS-B905

## MÉTODOS DE AJUSTE Y MEDIDA

### Instrumento de medición

- EVM(Voltímetro electrónico)
- Osciloscopio
- Frecuencímetro digital
- Oscilador AF
- ATT(Atenuador)
- Voltímetro CC
- Resistor(600Ω)

### Ajuste Azimutal de Cabeza

- Reproducir la porción de ajuste azimutal (8 kHz, -20 dB) de la cinta de prueba (QZZCFM). Variar el tornillo de ajuste azimutal hasta que las salidas del CH-I y CH-D se maximicen y la forma de onda de lissajous, como ilustrado, se acerque a grado 0.

Nota:

Si CH-I y CH-D no son maximizados en el mismo punto, ajustar al punto donde los niveles de cada canal sean maximizados e igualados.

- Efectuar el mismo ajuste en la modalidad de reproducción.

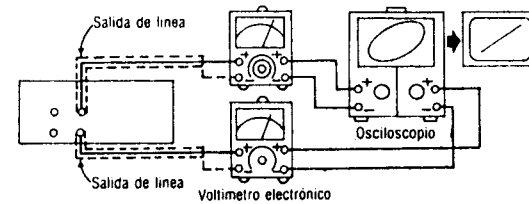

Fig. 1

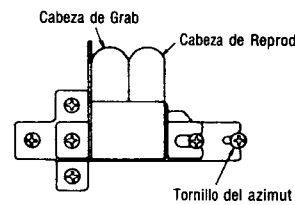

Fig. 2

### Ajuste de Velocidad de Cinta

- Reproducir la porción de la cinta prueba (QZZCWAT).
- Ajustar el VR en el motor (ver la Fig. 3) de manera que salida esté dentro del valor estándar.

Valor estándar: 3000 ± 15, -10Hz

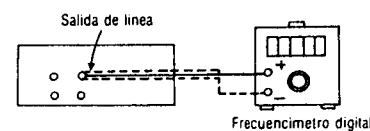

Fig. 3

### Ajuste de Ganancia de Reproducción

- Reproducir la porción ajustada de ganancia (315 Hz, 0 dB) de la cinta de prueba (QZZCFM).
- Ajustar VR1 (CH-I) y VR2 (CH-D) de manera que la salida esté dentro del valor estándar.

Valor estándar: 0.4V ± 0.5dB

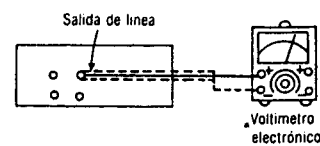

Fig. 4

### Respuesta de Frecuencia de Reproducción

- Reproducir la parte de respuesta de frecuencia de reproducción (315 Hz, 12.5 kHz ~ 63 Hz, -20 dB) de la cinta de prueba (QZZCFM).
- Asegurarse de que la respuesta de frecuencia esté dentro de la gama mostrada en la Fig. 6 para ambos CH-I y CH-D.

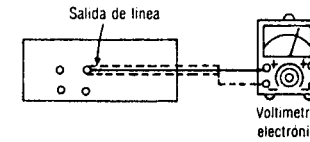

Fig. 5

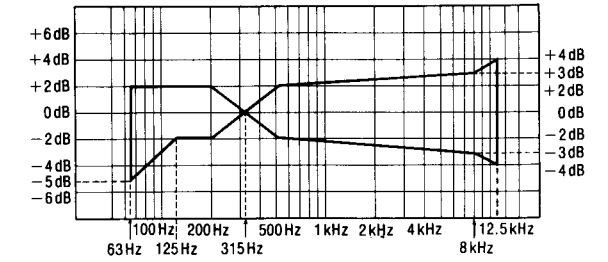

Fig. 6

### Ajuste de Medidor de Fluorescente

- Insertar la cinta de prueba en blanco normal (QZZCRA) y aplicar una señal de entrada de referencia (1 kHz, -24 dB) en la modalidad de Pausa de Grabación.
- Utilizando un atenuador, ajustarlo hasta que la tensión de los terminales "LINE OUT" (salida de línea) de las platinas de cinta sea 0.4 V

#### Ajuste de -40 dB

- Atenuar el nivel de entrada de señal en paso 1, por 40 dB y aplicarlo a la unidad.

- Ajustar VR61 de manera que el segmento "-40 dB" esté ligeramente iluminado.

#### Ajuste de 0 dB

- Poner el nivel de señal de entrada como indicado en el paso 2 de arriba.

- Ajustar VR62 de manera que el segmento "0 dB" esté ligeramente iluminado.

- Repetir los pasos 1 ~ 6 de arriba y asegurarse de que ambos segmentos, -40 dB y 0 dB, se iluminen ligeramente.

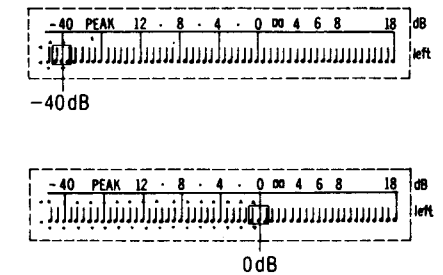

Fig. 7

### Respuesta de Frecuencia Total

- Poner una cinta virgen normal (QZZCRA) y poner la unidad en la modalidad de Pausa de Grabación.
- Aplicar la señal de entrada de referencia (1 kHz, -24 dB) a través de un atenuador.
- Atenuar la señal por 20 dB y ajustar la frecuencia de 50 Hz ~ 15 kHz.
- Grabar el barrido de frecuencia.
- Reproducir la señal grabada y asegurarse de que esté dentro de la gama mostrada en la Fig. 9 en comparación con la frecuencia de referencia (1 kHz).
- Si no está dentro de la gama de frecuencia, ajustar VR301 (CH-I) y VR302 (CH-D) de manera que el nivel de frecuencia esté dentro de la gama estándar.

- Subir el nivel en la gama de frecuencia alta..... Incrementar la corriente de polarización.
- Bajar el nivel en la gama de frecuencia baja..... Disminuir la corriente de polarización.

- Repetir los pasos 2 ~ 6 de arriba utilizando la cinta Cro2 (QZZCRX) y la cinta metálica (QZZCRZ) incrementando la gama de frecuencia a 16 kHz (50 Hz ~ 16 kHz).

- Asegurarse de que el nivel esté dentro de la gama mostrada en la Fig. 10.

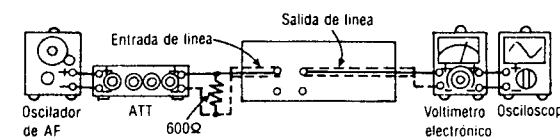

Fig. 8

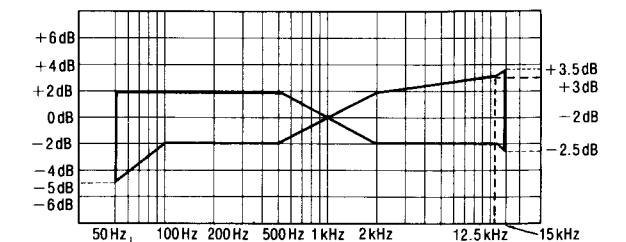

Fig. 9

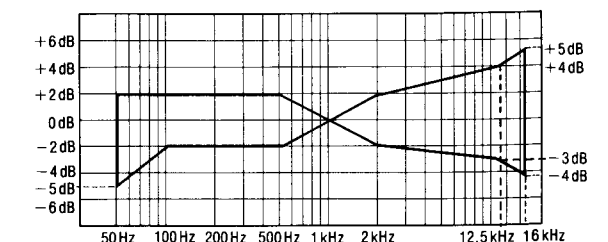

Fig. 10



### Ajuste de Ganancia Total

1. Insertar la cinta de prueba en blanco normal (QZZCRA) y poner la unidad en modalidad de pausa de Grabación.
2. Aplicar la señal de entrada de referencia (1 kHz, -24 dB). Atenuar la salida de manera que su nivel se haga 0.4 V.
3. Grabar la señal de entrada.
4. Reproducir la señal grabada en el paso 3 de arriba y asegurarse de que la salida esté dentro del valor estándar.
5. Si no está dentro del valor estándar, ajustar **VR151** (CH-I) y **VR152** (CH-D).
6. Repetir el paso 2 ~ 5 de arriba hasta que la salida esté dentro del valor estándar.

Valor estándar: 0.4V ± 0.5dB

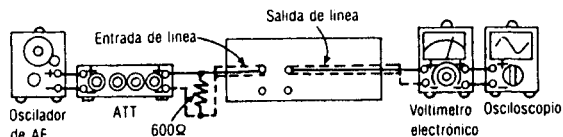

Fig. 11

### Ajuste de HX-PRO

1. Insertar la cinta en blanco metálica (QZZCRZ) y poner la unidad en la modalidad de pausa de Grabación.
2. Conectar un voltímetro CC a través de **R325** (CH-I, 10 ohmios) y **R326** (CH-D, 10 ohmios).
3. Ajustar **L303** (CH-I) y **L304** (CH-D) de manera que la tensión se haga menos de 110 mV CC.

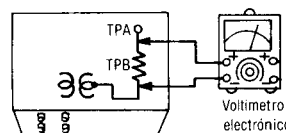

Fig. 12

TPA { TP305 (L-CH)  
TP306 (R-CH) } TPB { R325 (L-CH)  
R326 (R-CH) }

### Ajuste de Sincronización de dbx

#### Lado de Codificar

1. Poner el interruptor de reducción de ruido en la posición dbx.
2. Aplicar una señal de 1 kHz a los terminales "LINE IN" (entrada de línea) a través de un atenuador.
3. Conectar un voltímetro CC a través de **R565** (CH-I) y **R566** (CH-D). Ajustar el nivel de señal de entrada de manera que la tensión se haga 20 mV.
4. Conectar un voltímetro CC a través de **R550** (TP551) y ajustar **VR551** de manera que la tensión se haga 15 mV.

#### Lado de Descodificador

5. Repetir los pasos 1 y 2 de arriba.
6. Conectar un voltímetro CC a través de **R515** (CH-I) y **R516** (CH-D). Ajustar el nivel de señal de entrada de manera que la tensión sea 20 mV.
7. Conectar un voltímetro CC a través de **R500** (TP501) y ajustar **VR501** de manera que la tensión se haga 15 mV.

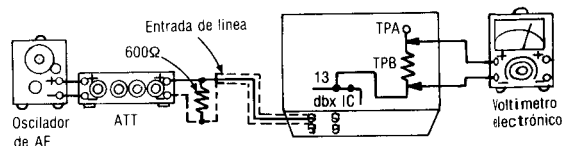

Fig. 13

TPA { TP551 (ENCODE)  
TP501 (DECODE) }

TPB { R550 (ENCODE)  
R500 (DECODE) }

### Ajuste de Ganancia de dbx

1. Insertar la cinta de prueba en blanco normal (QZZCRA) y poner la unidad en la modalidad de Grabación.
2. Aplicar una señal de 1 kHz a la "LINE IN" (entrada de línea) a través de un atenuador.
3. Ajustar el nivel de entrada de que la lectura del medidor sea 0 dB.
4. Conectar un voltímetro CC al terminal de "LINE OUT".
5. Conmutar la posición del interruptor de monitor entre "TAPE" (cinta) y "SOURCE" (fuente). Ajustar **VR553** (CH-I) y **VR554** (CH-D) de manera que la diferencia de tensión en "LINE OUT" esté dentro de 0.5 dB.

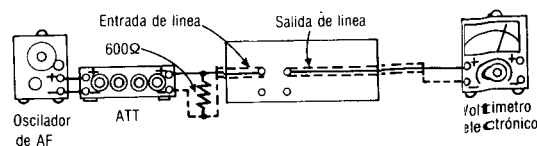

Fig. 14

# Service Manual

Cassette Deck

## RS-B905

**Supplement**

\*\* dbx/Closed Loop Dual Capstan  
DOUBLE DOLBY SYSTEM

Color

(K)... Black Type

\*  DOLBY B-C NR HX PRO

Color	Areas
(K)	[M] ..... U.S.A.
(K)	[MC]... Canada.
(K)	[E] ..... All European areas except United Kingdom.
(K)	[EK].... United Kingdom.
(K)	[EG] ... F.R. Germany.
(K)	[EH] ... Holland.
(K)	[XA].... Asia, Latin America, Middle East, Africa and Oceania.
(K)	[XL].... Australia.
(K)	[XB].... Saudi Arabia.

\* HX Pro headroom extension originated by Bang Olufsen and manufactured under license from Dolby Laboratories Licensing Corporation.

"DOLBY", the double-D symbol, and "HX PRO" are trademarks of Dolby Laboratories Licensing Corporation.

\*\* The term dbx is a registered trademark of dbx Inc.

Please file and use this supplement manual together with the service manual for model No. RS-B905, Order No. HAD8705124C0 and HAD8707218S0.

**Notes:**

- This supplement has been issued to inform you that the Erase Head has been changed in units having serial number suffixes "B" or later. (Refer to "How to read the serial number" on page 2.)
- The head was changed to improve the High-Pass Demagnetization.

### CHANGES

### REPLACEMENT PARTS LIST

Note: Part numbers are indicated on most mechanical parts. Please use this part number for parts order.

Ref. No.	Change of Parts No.		Description	Schematic Diagram Zone
	OLD	NEW		
<b>RESISTOR</b>				
R308	ERD25FJ561	.....	Deletion, Carbon, 560Ω, 1/4W [M, MC]	E-3
	ERG1SJ561	.....	Deletion, Metal Oxide, 560Ω, 1W [E, EK, EG, EH, XA, XL, XB]	

# Technics

Matsushita Services Company  
50 Meadowland Parkway,  
Secaucus, New Jersey 07094

Panasonic Sales Company,  
Division of Matsushita Electric  
of Puerto Rico, Inc.  
Ave. 65 De Infanteria, Km. 9.7  
Victoria Industrial Park  
Carolina, Puerto Rico 00630

Panasonic Hawaii, Inc.  
91-238, Kauh St. Ewa Beach  
P.O. Box 774  
Honolulu, Hawaii 96808-0774

Matsushita Electric  
of Canada Limited  
5770 Ambler Drive, Mississauga,  
Ontario, L4W 2T3

Matsushita Electric Trading Co., Ltd.  
P.O. Box 288, Central Osaka Japan

Ref. No.	Change of Parts No.		Description	Remarks
	OLD	NEW		
<b>MECHANISM PART</b>				
105	SMQA1192	SMQA1192-1	Erase Head	change

### ■ SCHEMATIC DIAGRAM

Note: R308 has deleted to improve the efficiency of the High-pass Demagnetization.

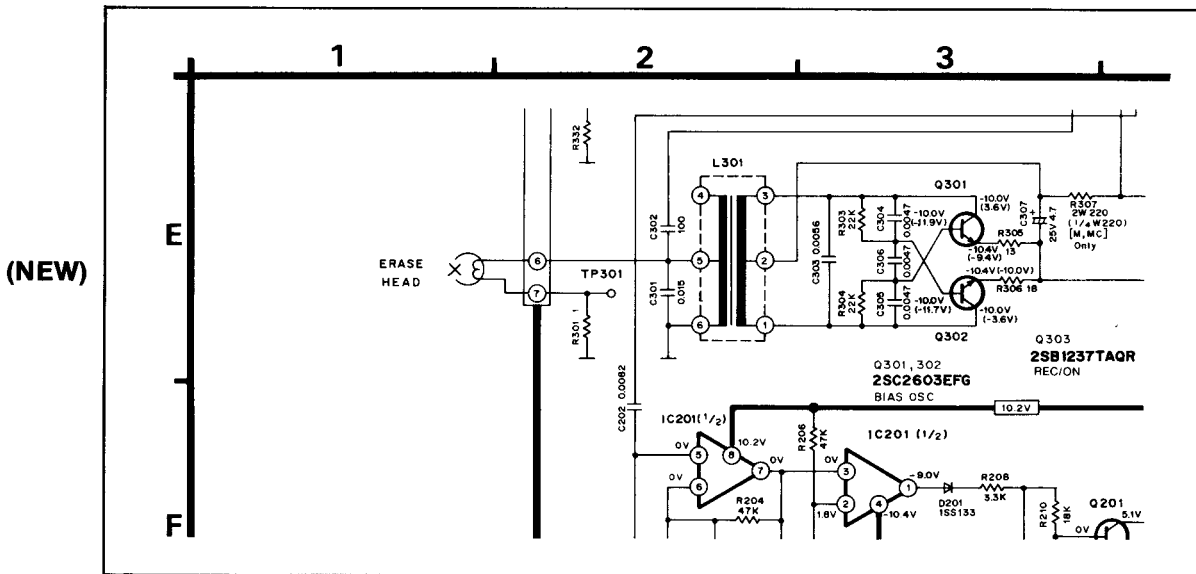
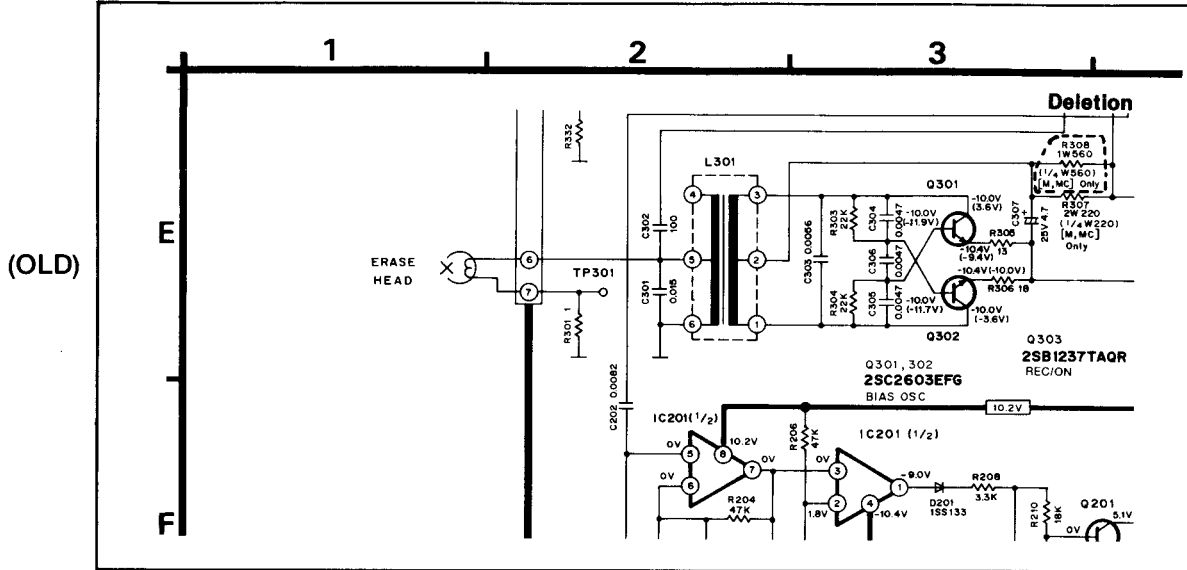

• How to read the serial number

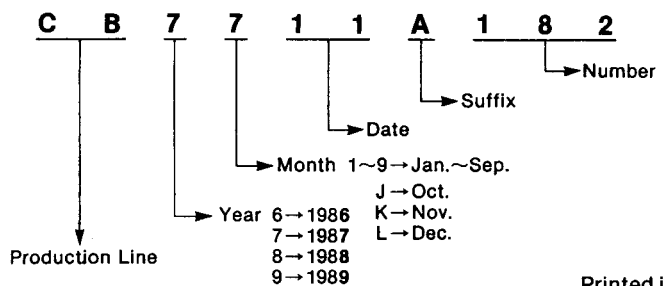

# Service Manual

Cassette Deck

## RS-B905

Color

(K)... Black Type

**Supplement**

\*\* dbx/Closed Loop Dual Capstan  
DOUBLE DOLBY SYSTEM

\*  DOLBY B-C NR HX PRO

Color	Areas
(K)	[M] ..... U.S.A.
(K)	[MC]... Canada.
(K)	[E] ..... All European areas except United Kingdom.
(K)	[EK]... United Kingdom.
(K)	[EG] ... F.R. Germany.
(K)	[EH] ... Holland.
(K)	[XA]... Asia, Latin America, Middle Near East, Africa and Oceania.
(K)	[XL].... Australia.
(K)	[XB].... Saudi Arabia.

\* HX Pro headroom extension originated by Bang Olufsen and manufactured under license from Dolby Laboratories Licensing Corporation.

"DOLBY", the double-D symbol, and "HX PRO" are trademarks of Dolby Laboratories Licensing Corporation.

\*\* The term dbx is a registered trademark of dbx Inc.

Please file and use this supplement manual together with the service manual for model No. RS-B905, Order No. HAD8705124C0.

**Notes:**

- The circuit of RS-B905 has been changed for the improvement of performance.

### CHANGES

### REPLACEMENT PARTS LIST

**Notes:** • Part numbers are indicated on most electrical parts. Please use this part number for parts order.

• Important safety notice:

Components identified by the  $\Delta$  mark have special characteristics important for safety.

When replacing any of these components, use only manufacturer's specified parts.

Ref. No.	Change of Parts No.		Part Name & Description	Per Set (Pcs.)	Remarks
	OLD	NEW			
<b>RESISTORS</b>					
R5, 6	ERDS2TJ684	<b>ERDS2TJ474</b>	Carbon, 1/4W, 470k $\Omega$ , $\pm 5\%$	2	
R7, 8	ERDS2TJ183	<b>ERDS2TJ113</b>	Carbon, 1/4W, 11k $\Omega$ , $\pm 5\%$	2	
R9, 10	ERDS2TJ103	<b>ERDS2TJ752</b>	Carbon, 1/4W, 7.5k $\Omega$ , $\pm 5\%$	2	
R163, 164	ERDS2TJ121	<b>ERDS2TJ181</b>	Carbon, 1/4W, 180 $\Omega$ , $\pm 5\%$	2	
R165, 166	ERDS2TJ331	<b>ERDS2TJ181</b>	Carbon, 1/4W, 180 $\Omega$ , $\pm 5\%$	2	
R171, 172	ERDS2TJ471	<b>ERDS2TJ102</b>	Carbon, 1/4W, 1k $\Omega$ , $\pm 5\%$	2	
R175, 176	ERDS2TJ102	<b>ERDS2TJ561</b>	Carbon, 1/4W, 560 $\Omega$ , $\pm 5\%$	2	
R185, 186	ERDS2TJ682	<b>ERDS2TJ103</b>	Carbon, 1/4W, 10k $\Omega$ , $\pm 5\%$	2	
R457, 458	ERDS2TJ123	<b>ERDS2TJ682</b>	Carbon, 1/4W, 6.8k $\Omega$ , $\pm 5\%$	2	
R503, 504	ERDS2TJ274	<b>ERDS2TJ472</b>	Carbon, 1/4W, 4.7k $\Omega$ , $\pm 5\%$	2	

Matsushita Services Company  
50 Meadowland Parkway,  
Secaucus, New Jersey 07094

Panasonic Hawaii, Inc.  
91-238, Kauh St. Ewa Beach  
P.O. Box 774  
Honolulu, Hawaii 96808-0774

Matsushita Electric Trading Co., Ltd.  
P.O. Box 288, Central Osaka Japan

Panasonic Sales Company,  
Division of Matsushita Electric  
of Puerto Rico, Inc.  
Ave. 65 De Infanteria, KM 9.7  
Victoria Industrial Park  
Carolina, Puerto Rico 00630

Matsushita Electric  
of Canada Limited  
5770 Ambler Drive, Mississauga,  
Ontario, L4W 2T3

# Technics

Ref. No.	Change of Parts No.		Part Name & Description	Per Set (Pcs.)	Remarks
	OLD	NEW			
<b>CAPACITORS</b>					
C9, 10	ECQM1H472JZ	<b>ECQM1H682JZ</b>	Polyester, 50V, 0.0068 $\mu$ F, $\pm$ 5%	2	
C165, 166	ECQM1H183JV	<b>ECQM1H223JZ</b>	Polyester, 50V, 0.022 $\mu$ F, $\pm$ 5%	2	
C505, 506	ECQM1H183JZ	<b>ECQM1H472JZ</b>	Polyester, 50V, 0.0047 $\mu$ F, $\pm$ 5%	2	
C610	ECKD1H223PF	_____	_____ [EK] only	1	<b>Deletion</b>
C610	_____	<b>ECKD1H223PF</b>	Ceramic, 50V, 0.022 $\mu$ F, $\pm$ 100% [EG, XL] only	1	<b>Addition, <math>\Delta</math></b>
<b>TRANSISTORS</b>					
Q901	2SD1225RM	<b>2SD1858TAQR</b>	Transistor	1	
Q914	2SD1225RM	<b>2SD1858TAQR</b>	Transistor [M, MC] only	1	
Q916	2SD1225RM	<b>2SD1858TAQR</b>	Transistor [M, MC] only	1	