

Service Manual

Cassette Deck

RS-CH510

*1  DOLBY B NR

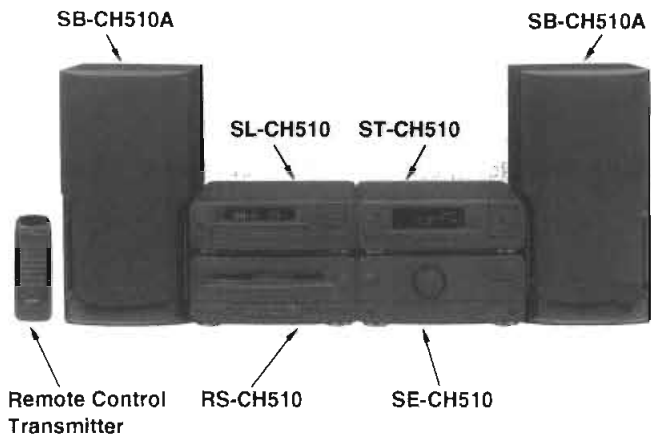

Colour

(K) Black Type

Area

Suffix for Model No.	Area	Colour
(E)	Europe, Asia, Latin America, Middle Near East and Africa and Oceania	(K)

Because of unique interconnecting cables, when a component requires service, send or bring in the entire system.

System: SC-CH510

* 1 : Dolby noise reduction manufactured under license from Dolby Laboratories Licensing Corporation.
 "Dolby" and the double-D symbol are trade marks of Dolby Laboratories Licensing Corporation.

AR-1 MECHANISM SERIES

Specifications

Deck system	Stereo cassette deck
Track system	4 track, 2 channel
Recording system	AC bias
Bias frequency	80 kHz
Erasing system	AC erase
Heads	
Deck 1 (Playback head)	Permalloy head
Deck 2 (Recording/Playback head)	Permalloy head
(Erasing head)	Double gap ferrite head
Motors	
Deck 1, 2	
Capstan drive	DC servo motor
Reel table drive	DC motor
Tape speed	4.8 cm/sec
Wow and flutter	0.1% (WRMS)
Fast forward and rewind times	Approx. 50 seconds with C-60 cassette tape

Frequency response (Dolby NR off, CCRT on)

NORMAL	20 Hz – 17 kHz
	30 Hz – 15 kHz (DIN)
CrO₂	20 Hz – 18 kHz
	30 Hz – 17 kHz (DIN)
METAL	20 Hz – 20 kHz
	30 Hz – 19 kHz (DIN)

S/N (Signal level = max recording level, CrO₂)

NR off	56 dB (A weighted)
Dolby NR on	66 dB (CCIR)

Input sensitivity and impedance

LINE IN	126 mV/17.6 kΩ
----------------	----------------

Output voltage and impedance

LINE OUT	400 mV/220 Ω
-----------------	--------------

General

Dimensions (W × H × D)	270 × 118.5 × 263 mm
Weight	2.85 kg

Notes:

Specifications are subject to change without notice.
 Weight and dimensions are approximate.

System	Tuner/sound processor	Compact disc player	Amplifier	Cassette Deck	Speakers
SC-CH510	ST-CH510	SL-CH510	SE-CH510	RS-CH510	*2 SB-CH510A

Technics®

* 2: For Europe Made in PAES
 For other areas Made in NABEL

■ Contents

	Page		Page
● Location of Controls	2	● Block Diagram	26, 27
● Operation Check and Main Component Replacement Procedures	3~8	● Self-Check Function	28~30
● Measurements and Adjustments	9~13	● Function of IC Terminals	30, 31
● Schematic Diagram	14~20	● Replacement Parts List	32~37
● Printed Circuit Board Diagram	21~24	● Cabinet Parts Location	38
● Wiring Connection Diagram	25	● Mechanism Parts Location	39~42

NOTE:

Refer to the service manual for Model No. SE-CH510 (ORDER No. AD9407197C8) for information on "Accessories", "Stacking the Components", "Connections" and "Packaging".

■ Location of Controls

- ① Deck 1 holder open button
- ② Deck 1 cassette holder
- ③ Deck 1 holder close button
- ④ Stop button
- ⑤ Deck 2 holder close button
- ⑥ Deck 2 cassette holder
- ⑦ Deck 2 holder open button
- ⑧ Dolby noise reduction button and indicators
- ⑨ Reverse mode button and indicators
- ⑩ Deck 1/deck 2 select button and indicators
- ⑪ Playback buttons and indicators
- ⑫ Fast forward/rewind/tape program sensor buttons
- ⑬ One-touch tape edit buttons
- ⑭ Record pause button and indicator
- ⑮ CCRT button and indicator

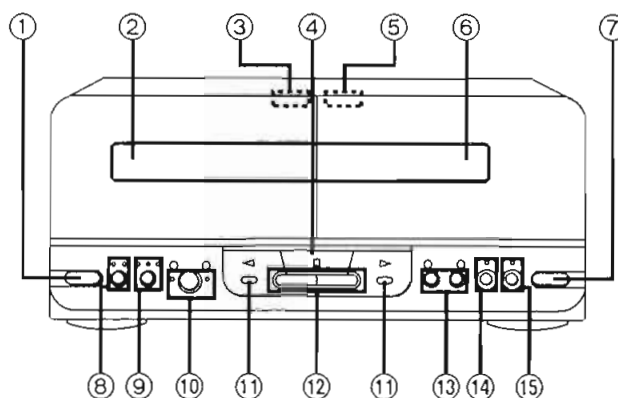

■ Operation Check and Main Component Replacement Procedures

NOTE

1. This section describes procedures for checking the operation of the major printed circuit boards and replacing the main components.
2. For reassembly after operation checks or replacement, reverse the respective procedures. Special reassembly procedures are described only when required.
3. Select items from the following index when checks or replacement are required.
4. Illustrated screws are equivalent to actual size.
5. Refer the parts No. on the page of "Main Component Replacement Procedures", if necessary.

● Contents

Page

● Checking Procedure for each P.C.B.

1. Checking for the motor P.C.B. 3.
2. Checking for the main P.C.B. 4.
3. Checking for the operation P.C.B. 4, 5.

● Main Component Replacement Procedures

1. Replacement for the head block and pinch roller unit 5, 6.
2. Replacement for the belt, reel motor unit and capstan motor unit 7.
3. Replacement for the parts mounted on mechanism P.C.B. and solenoid unit 8.

■ Checking Procedure for each P.C.B.

1. Checking for the motor P.C.B.

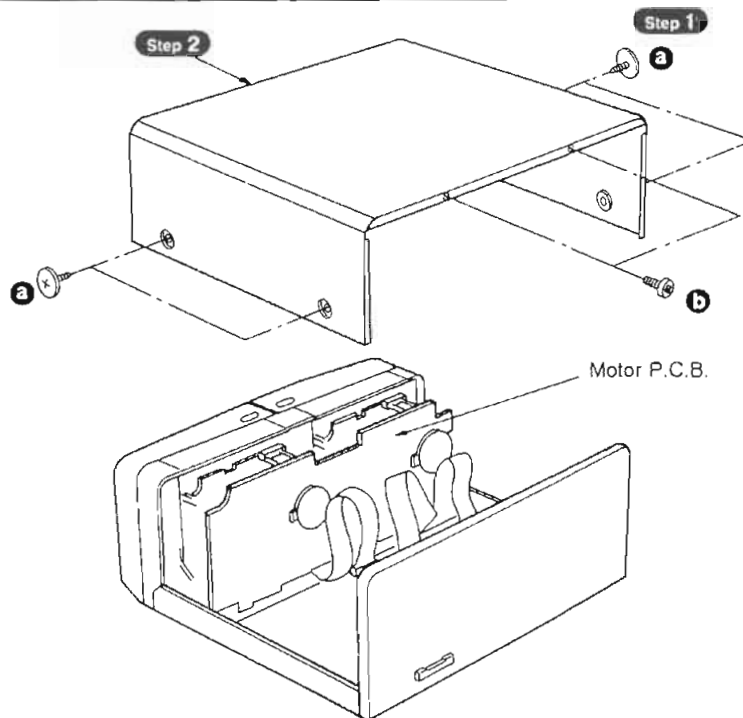

[RHD30007] (Black)



[XTBS3+8JFZ1] (Black)

2. Checking for the main P.C.B.

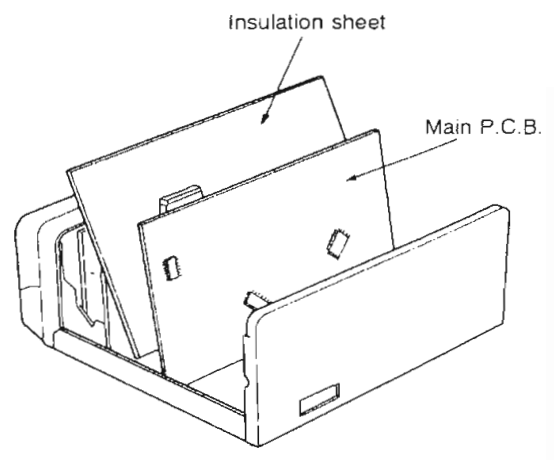
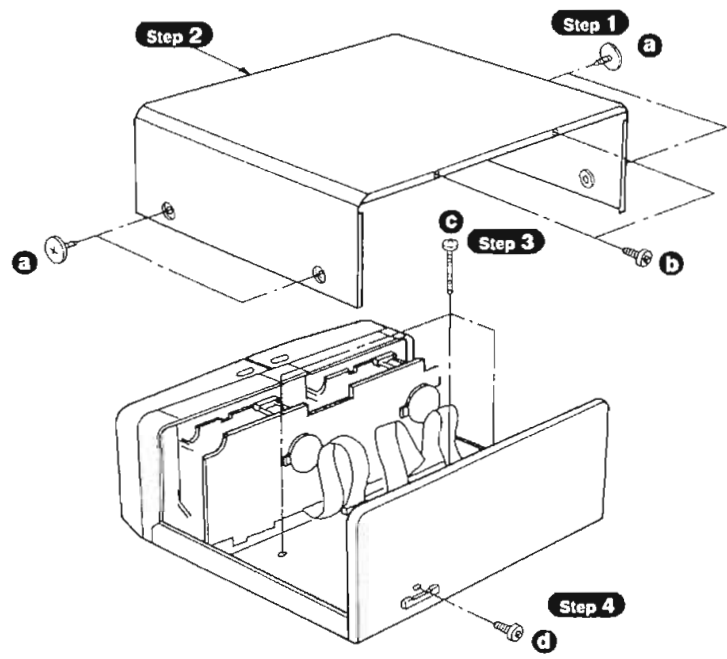

- a** [RHD30007] (Black)
- c** [XTB3+16JFZ] (Black)
- b, d** [XTBS3+8JFZ1] (Black)

3. Checking for the operation P.C.B.

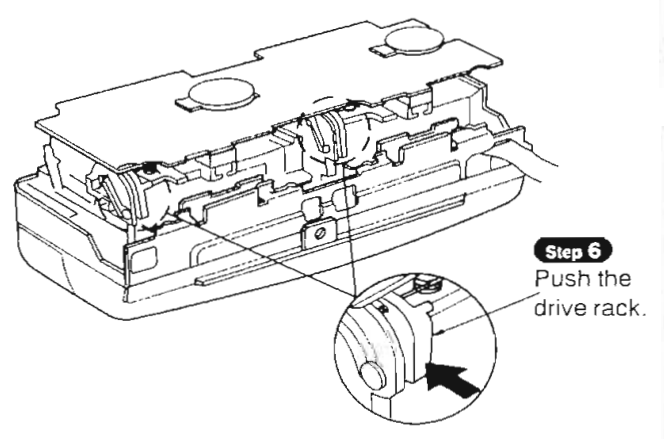
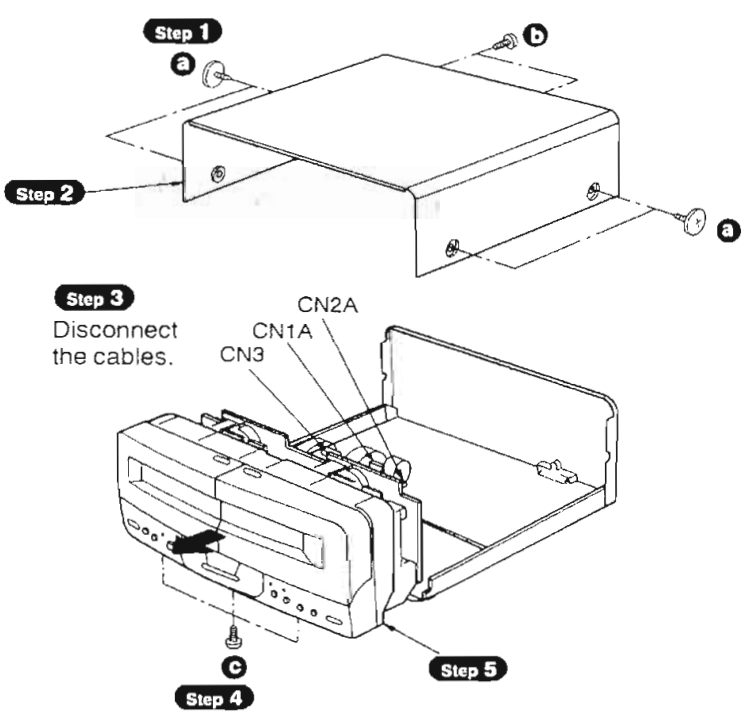

- a** [RHD30007] (Black)
- b, c** [XTBS3+8JFZ1] (Black)

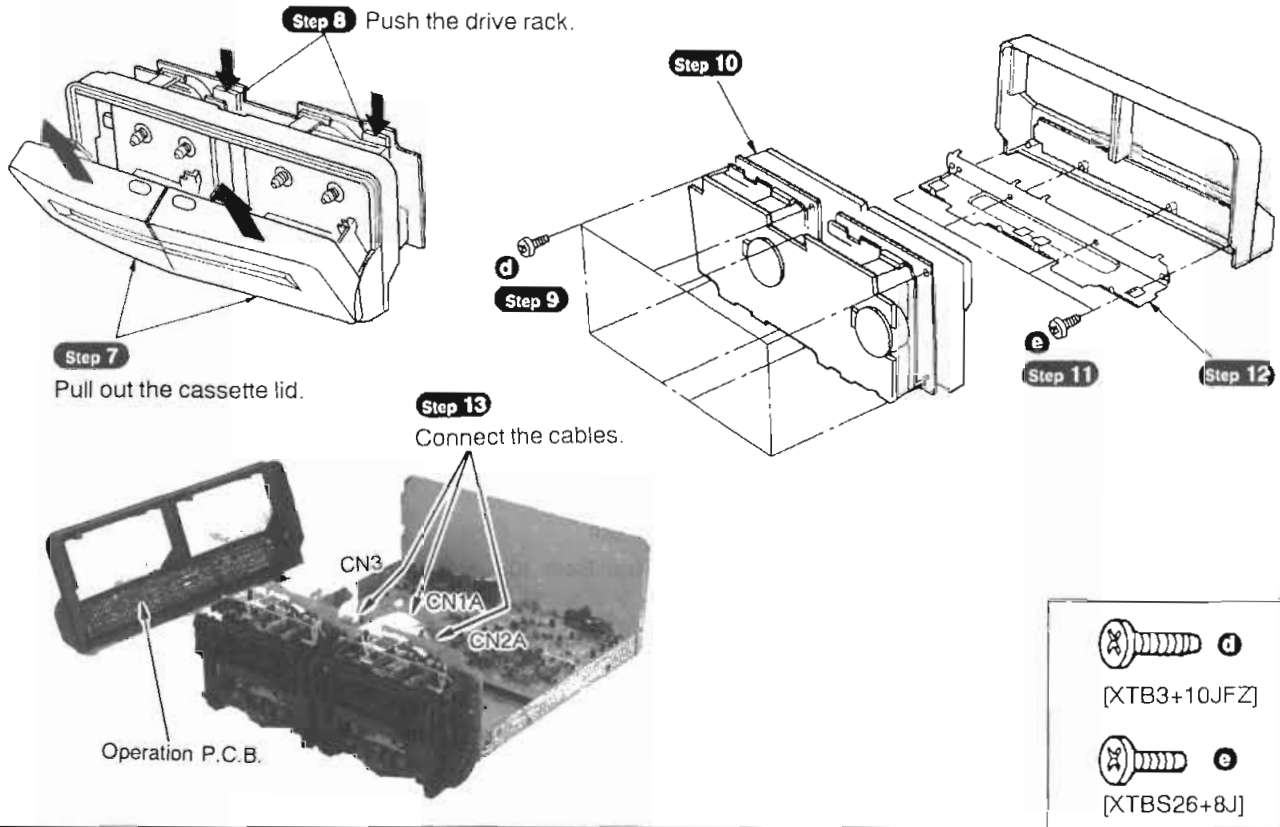

■ Main Component Replacement Procedures

1. Replacement for the head block and pinch roller unit

- Follow the **Step 1** ~ **Step 10** of the item 3 in checking procedure for each P.C.B. on page 4, 5.

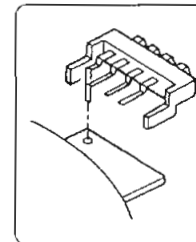
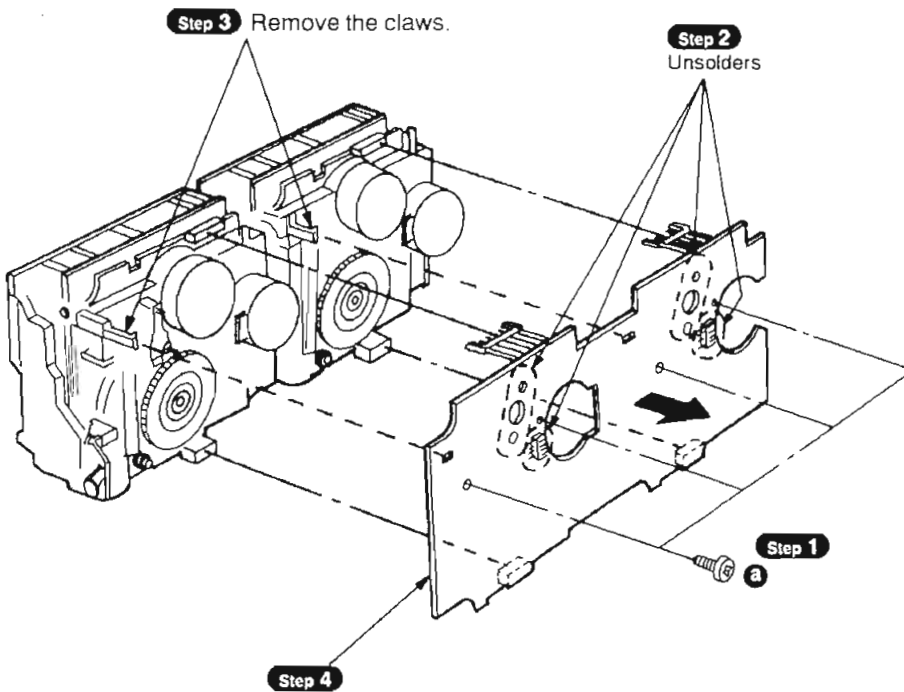
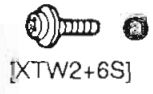

NOTE

Handle the connector with care so that the shape of terminal is different from others.

Step 8

Remove the cassette holder ass'y from the boss of drive rack.

Boss of drive rack

Step 6

Pull out the pin.

Step 7

Push the drive rack.

Step 5

Head Connector

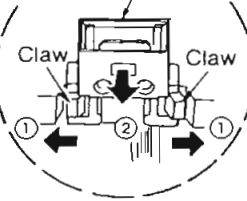

b

[XTW2+5L]

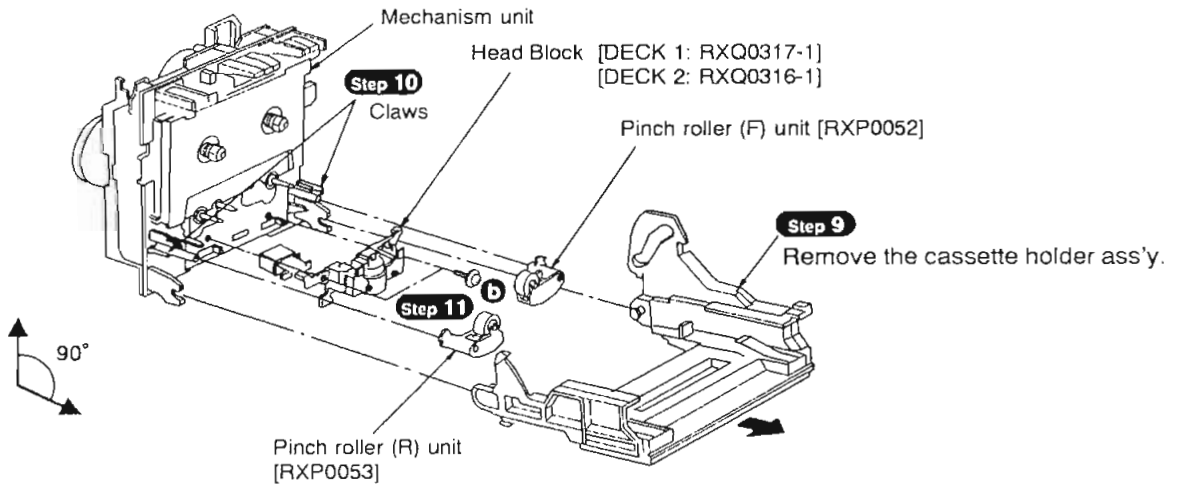

Installation of the cassette holder ass'y after replacement

Step 1 Locate the cassette holder ass'y and mechanism unit at a 90 degree angle, and then install the cassette holder ass'y.

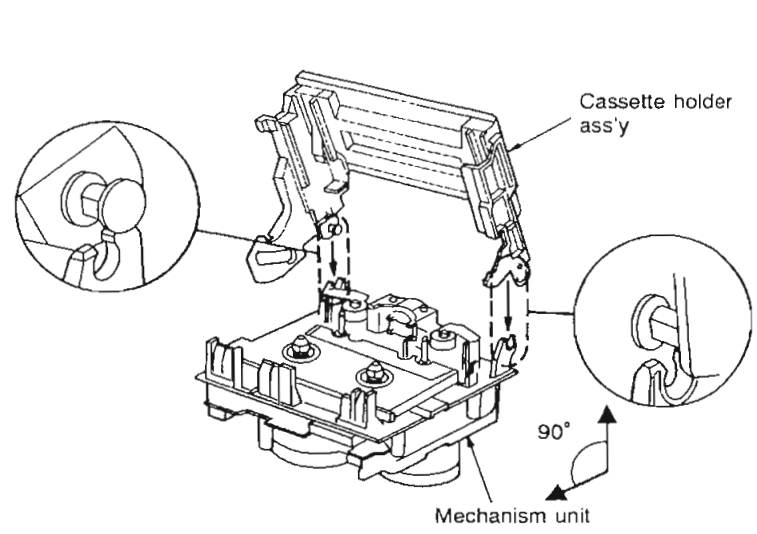

Step 3 Close the cassette holder ass'y.

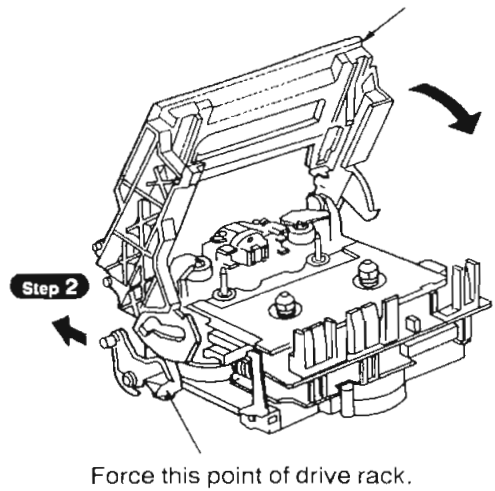

2. Replacement for the belt, reel motor unit and capstan motor unit

- Follow the **Step 1** ~ **Step 8** of item 1 in main component replacement procedures on page 5, 6.

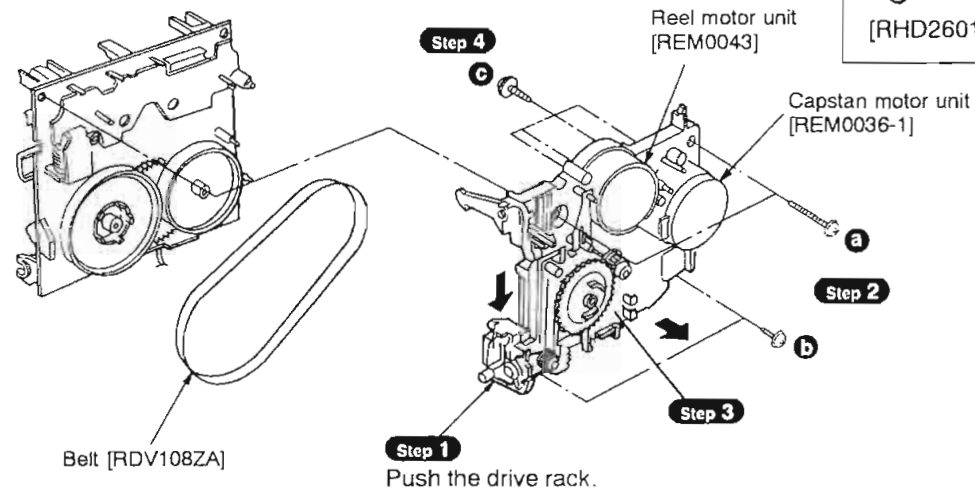
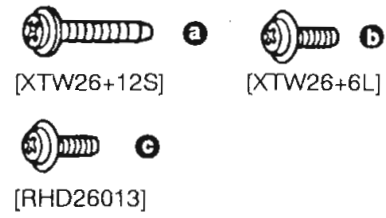

Installation of the sub chassis ass'y after replacement

- Step 1** Place the idle gear in the center.

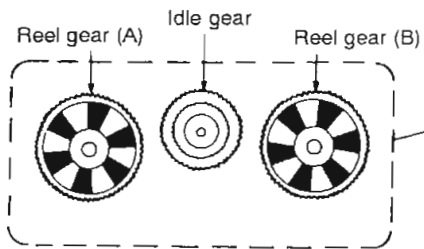

- Step 2** Temporarily secure the belt.

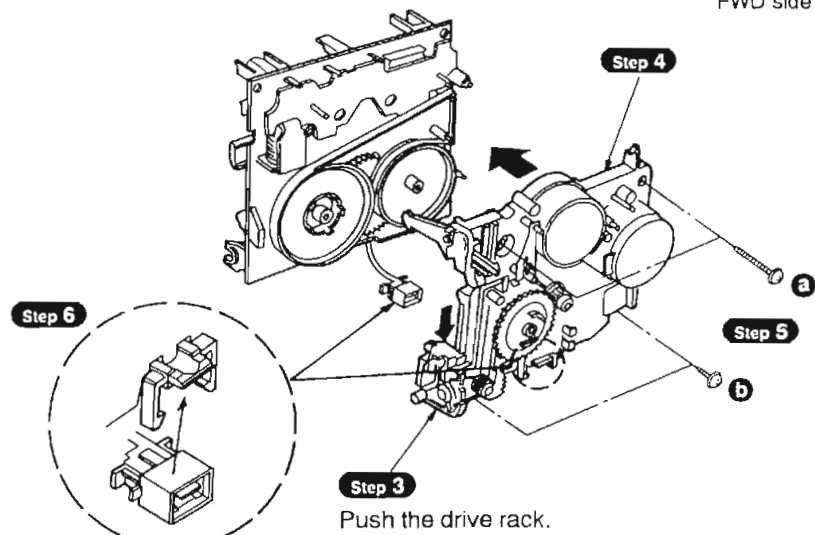
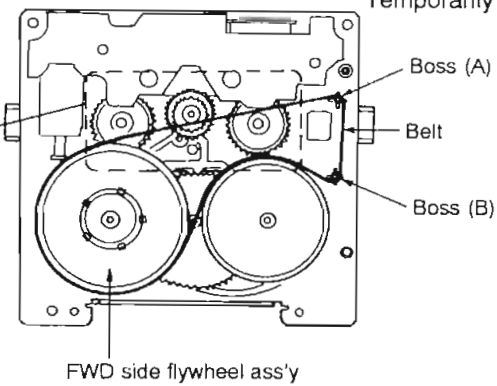

- Step 7** Secure the belt with the capstan motor pulley.

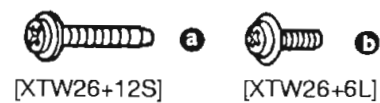
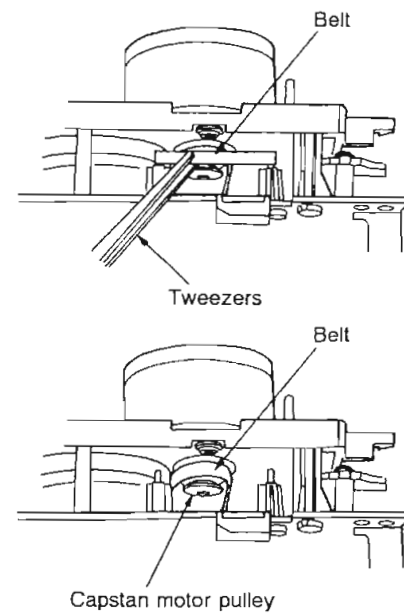

3. Replacement of the parts mounted on mechanism P.C.B. and solenoid unit

- Follow the **Step 1** ~ **Step 3** of item 2 in main component replacement procedures on page 7.

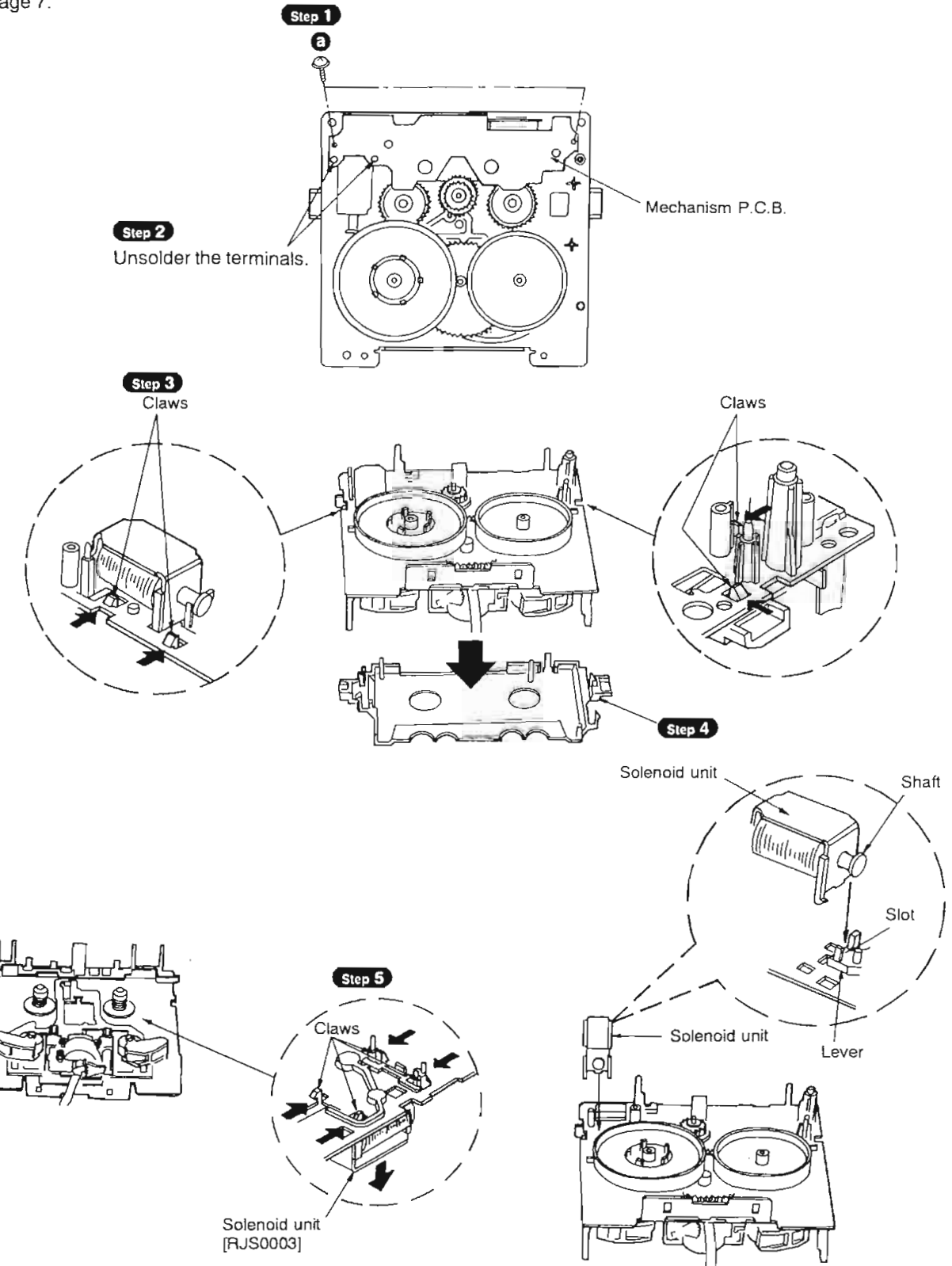

- NOTE**
 Notice for installing the solenoid unit
 • The shaft of solenoid unit should be aligned with the slot of lever.

■ Measurements and Adjustments

This unit RS-CH510 is designed to operate on power supplied from the Amplifier (SE-CH510) through Tuner/Sound Processor (ST-CH510).

When connecting the unit to other system components, do not connect to the Amplifier (SE-CH510) directly. Be sure to connect this unit through the Tuner/Sound Processor (ST-CH510).

When operating the unit RS-CH510 alone for testing and servicing, without having power supplied from the Amplifier (SE-CH510) and the Tuner/Sound Processor (ST-CH510), use the following method.

● To Supply Power Source

- Short test points between **TP604** and **TP605**, and **TP606** and **TP607** at the resistor **R609** as shown in Fig. 1.
- Apply 11 V AC power to test points between **TP601** and **TP602** (GND), and **TP603** and **TP602** (GND). (10 V AC power can be also applied when using adjustment tool for power supply.)

● To Check Signals

Connect an oscilloscope or a built-in amplifier speaker between line output for L-ch (**TP3**) and jumper (**TP5**), and line out for R-ch (**TP4**) and jumper (**TP5**) and check if the signals are outputting from this unit.

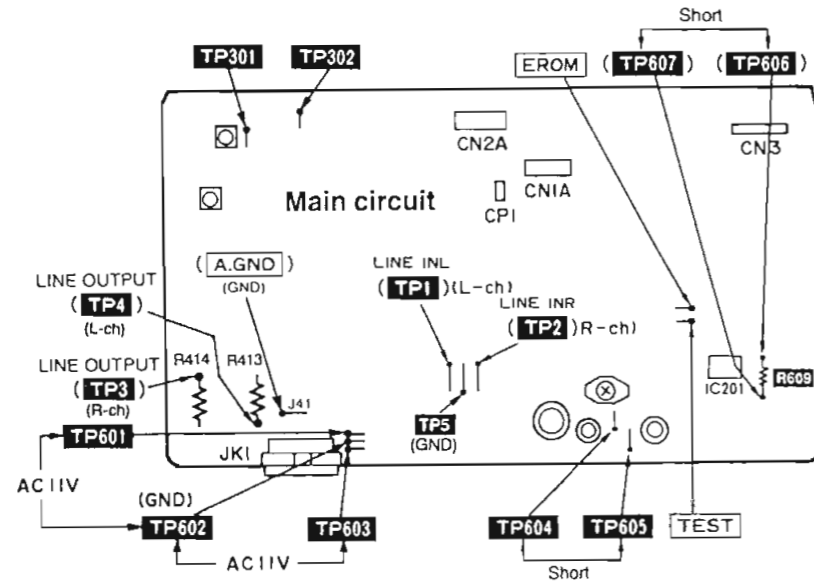

Fig. 1

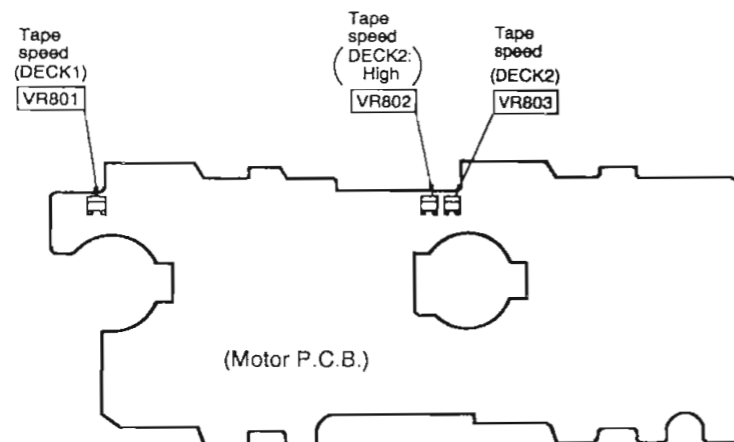

Fig. 2

Measurement Condition

- Reverse-more selector switch; \rightleftarrows
- Dolby NR switch; OFF
- Make sure heads are clean.
- Make sure capstan and pressure roller are clean.
- Judgeable room temperature $20 \pm 5^\circ\text{C}$ ($68 \pm 9^\circ\text{F}$)

Measuring instrument

- EVM (Electronic Voltmeter)
- AF oscillator
- Digital frequency counter

Test tape

- Head azimuth adjustment (8 kHz, -20 dB); QZZCFM
- Tape speed adjustment (3 kHz, -10 dB); QZZCWAT
- Playback gain adjustment (315 Hz, 0 dB); QZZCFM
- Recording frequency response adjustment; QZZCRA (Normal blank Tape)

HEAD AZIMUTH ADJUSTMENT (DECK 1/2)

- Connect the measuring instrument as shown in Fig. 3.
- Replace azimuth screws for both forward and reverse direction after removing the screw-locking bond left on the head base. Fine adjustment of azimuth can not be performed with remaining the bond on the head base. (Supply part No. of azimuth adjusting screw: RHD17015)
- Playback the azimuth adjustment portion (8 kHz, -20 dB) of test tape (QZZCFM). Adjust the azimuth adjusting screw until the outputs of the L/R-ch are maximized. (Refer to Fig. 4.)
- Perform the same adjustment in reverse playback mode.

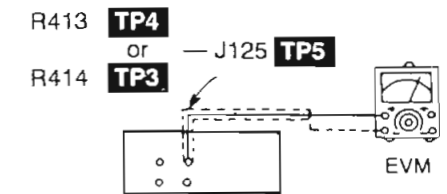

Fig. 3

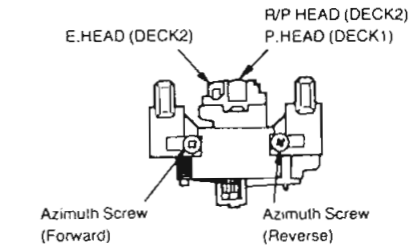

Fig. 4

Check of the level difference forward and reverse directions

- Playback the playback gain adjustment portion (315 Hz, 0 dB) of test tape (QZZCFM). Check if level difference between forward and reverse direction is within 1 dB.
- After the adjustment, apply screwlock to the azimuth adjusting screw.

TAPE SPEED ADJUSTMENT (DECK 1/2)

Normal speed (Standard value: 3000 ± 45 Hz)

- Playback the middle portion of the test tape (QZZCWAT).
- Adjust Deck 1 = **VR801** and Deck 2 = **VR803** for the output value shown below. (Refer to Fig. 2.)

Adjustment target: 3000 ± 15 Hz (NORMAL speed)
Standard value: 3000 ± 45 Hz (NORMAL speed)

High speed [Set the unit to forward (FWD) mode.]

- Short-circuit the TEST jumper ("DECK 1" or "DECK 2" indicator blinks).
- Playback the middle portion on the test tape (QZZCWAT).
- Press the one touch tape edit (High) button. This will set the high speed mode.
- At that time, check if the output from DECK 1 is within the standard value.

Standard value: 6000 ± 600 Hz (HIGH speed)

- Adjust **VR802** so that the output frequency of DECK 2 is within ± 30 Hz for the value of the output frequency of DECK 1. (Refer to Fig. 2.)

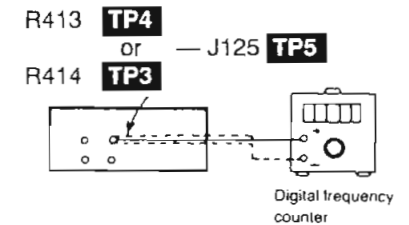

Fig. 5

ERASE CURRENT CONFIRMATION (DECK2)

- Short-circuit the TEST jumper.
- Press the REC PAUSE button.
- Check if the output at this time between the erase current confirmation point **TP301** and **TP302** (chassis) (the output on both edged of R301) is within the standard value. (Refer to Fig. 6.)

Standard value: 160 ± 25 mA

- Disconnect the TEST jumper from the frame ground.

NOTE:

The test tape is not required when confirming the erase current.

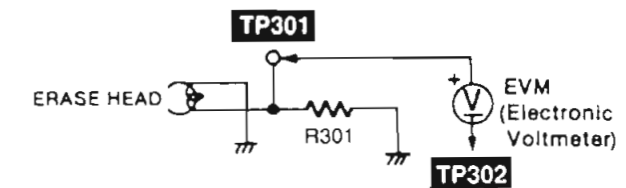

Fig. 6

The RS-CH510 can automatically adjust playback gain and rec./play frequency response & gain.

Automatic adjustment of playback gain and rec./play frequency response & gain

A microprocessor (IC701) used within the RS-CH510 automatically adjusts its playback gain and rec./play frequency response & gain (factory adjustment) and stores adjustment data to an EEPROM chip (IC702). (potentiometers have conventionally been used for these adjustments.)



If the EEPROM chip (IC702) or any of the head AF signal line components is replaced for servicing, the unit requires readjustment. (Refer to page 11, 12.)

●Preparation for making automatic adjustments

- Find the beginning of the 315 Hz, 0 dB test signal recorded on the test tape (QZZCFM).
- Switch off the power to the unit and then make the following connections.
 - Connect an AF oscillator between **TP1** (LINE IN, left channel) and **TP5**, and between **TP2** (LINE IN, right channel) and **TP5**. (Refer to Fig. 1 and Fig. 7.)
 - Connect an EVM (AC range) between **TP3** (LINE OUT, left channel) and **TP5**, and between **TP4** (LINE OUT, right channel) and **TP5**. (Refer to Fig. 1 and Fig. 7.)
 - Connect **EROM** and **TEST** to the **A. GND**. (Refer to Fig. 1 and Fig. 8.)
 - When **EROM** is connected to the **A. GND** and the power is switched on, the memory of the EEPROM (IC702) will be erased.
 - When **TEST** is connected to the **A. GND** and the power is switched on, the unit will be in the adjustment mode.
- Switch on the power to the unit. (Refer to page 9 for information on how to connect the power supply.)
 - The Deck 1/2 indicators and the CCRT indicator will begin flashing. (Refer to Fig. 9.)
- Use the AF oscillator to apply a 315 Hz, -20 dB (100 mV) signal to the unit.
- Without a tape inserted in either Deck 1 or Deck 2, hold the REC PAUSE button down and confirm that the signal is being output from **TP3** and **TP4**.
 - The signal is output from **TP3** and **TP4** only while the REC PAUSE button is held down. When the button is released, the output will stop.
- Adjust the output of the AF oscillator so that the output from **TP3** and **TP4** becomes 400 mV, and then hold the REC PAUSE button down again for at least 5 seconds.
 - The reference signal will be stored in the memory of the EEPROM (IC702).
- Release the REC PAUSE button.
- Disconnect **EROM** from the **A. GND**.
 - Leave **TEST** connected to the **A. GND**. (The Deck 1/2 indicators are flashing at this time.)

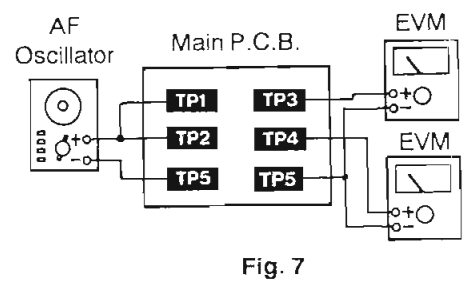

Fig. 7

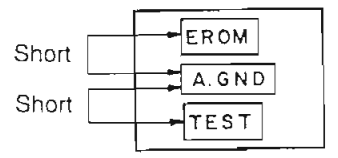

Fig. 8

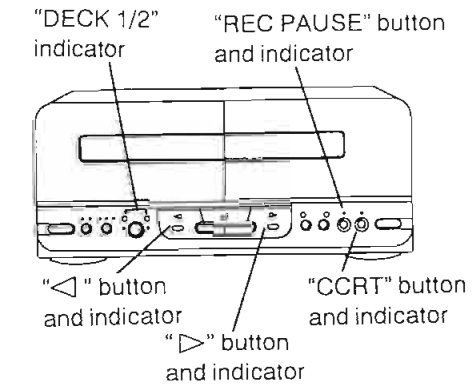
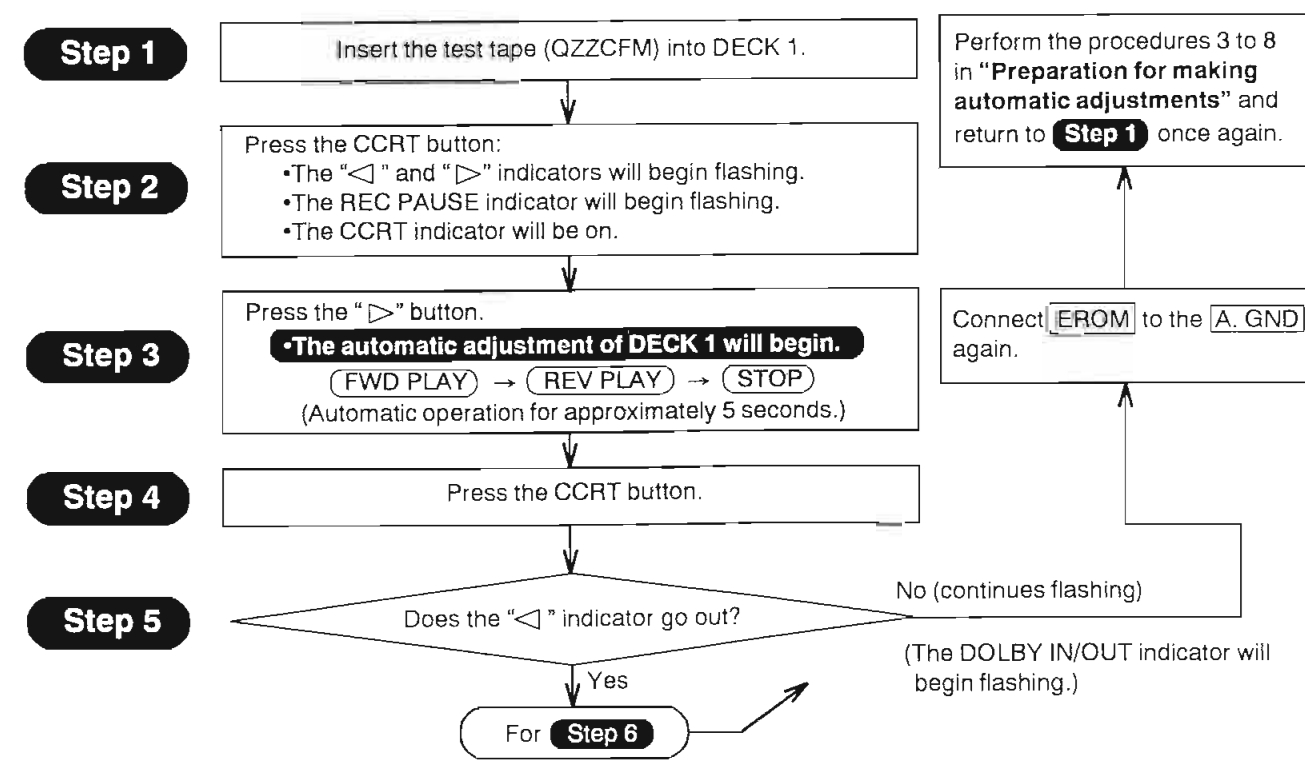
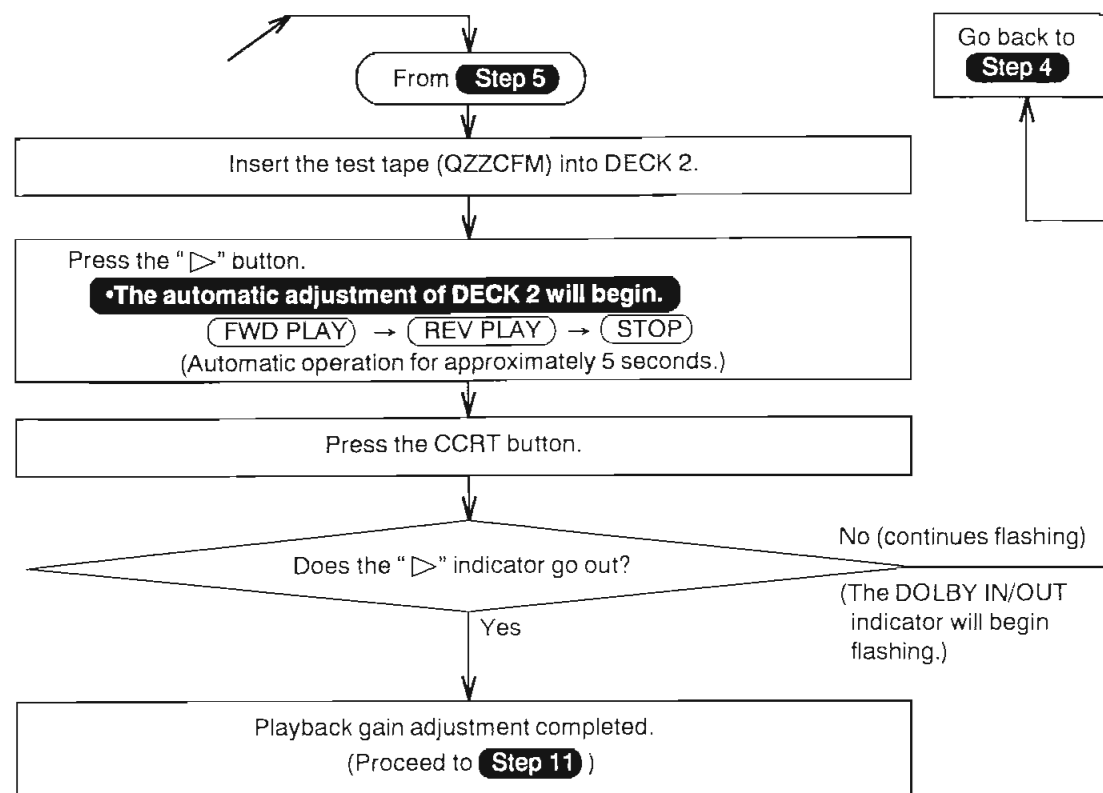
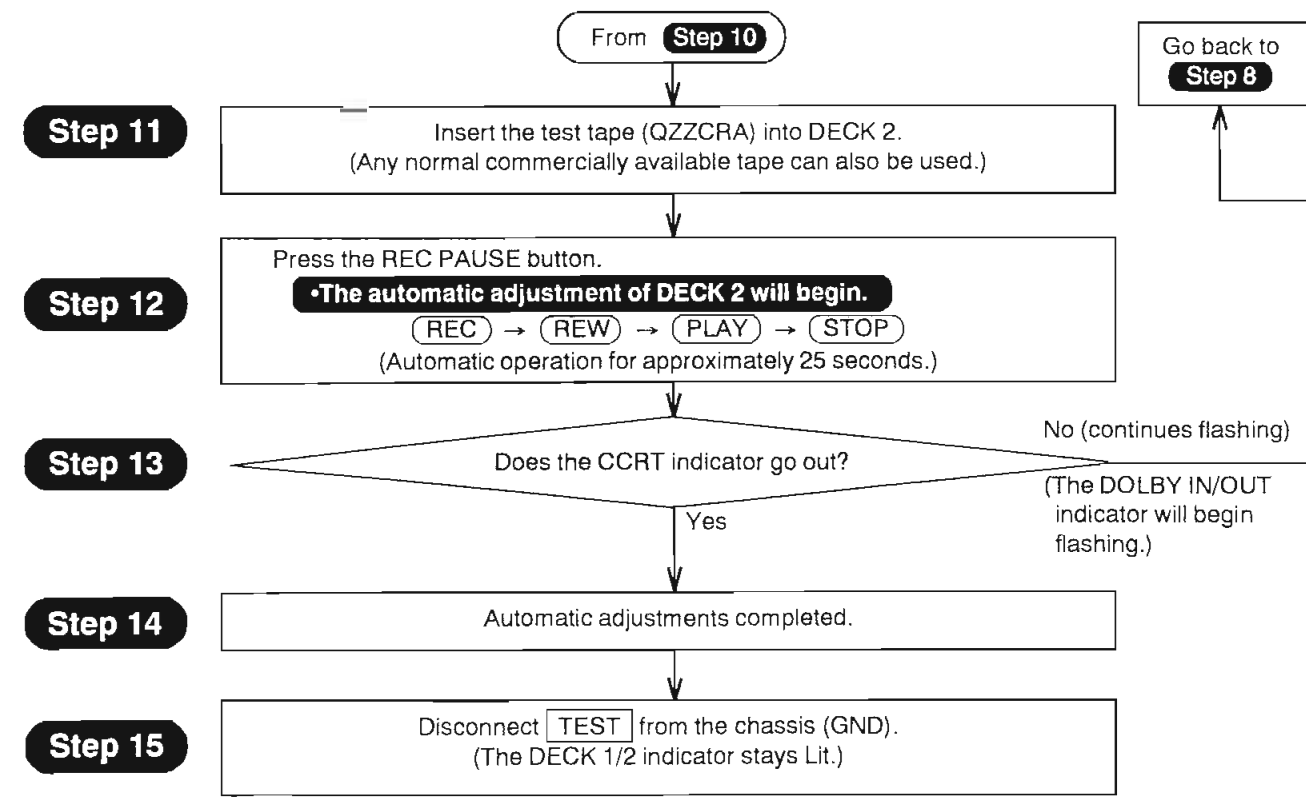

Fig. 9

●PLAYBACK GAIN ADJUSTMENT



●OVERALL GAIN ADJUSTMENT AND OVERALL FREQUENCY ADJUSTMENT



●Perform the following recording/playback frequency response and gain adjustment checks

- Playback gain check**
 - Find the start of the 315 Hz/0 dB section of the test tape (QZZCFM), insert the tape into Deck1 and 2, and play it back (FWD).
 - Confirm that the output between **TP3 / TP4** and **TP5** agrees with the following rated value:
400 mV ± 0.5 dB
- Playback frequency response check (Decks 1 and 2)**

Playback the 315 Hz/-20 dB and 12.5 kHz to 63 Hz/-20 dB sections of the test tape (QZZCFM) and then, using the 315 Hz/-20 dB playback output as a reference (0 dB), confirm that the playback frequency response is within the range shown in Fig. 10.

Output points: between **TP3 / TP4** and **TP5**.

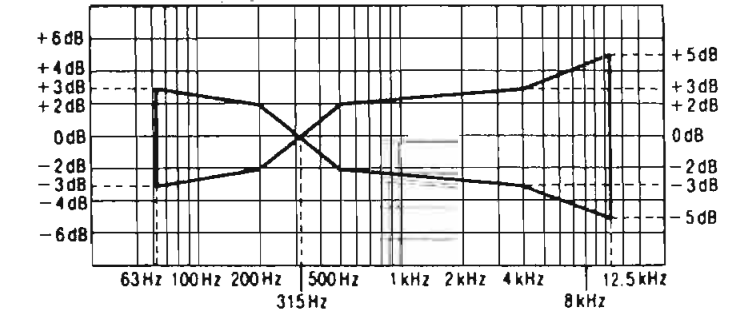

Fig. 10

3. Recording/playback frequency response and gain check

- Insert a Normal-type blank tape (QZZCRA) into Deck 2.
- Input a 1 kHz signal between **TP1 / TP2** and **TP5**, and use the attenuator to set the output between **TP3 / TP4** and **TP5** to 400 mV.
- Record the 1 kHz signal.
- Playback the recorded signal and confirm that the output between **TP3 / TP4** and **TP5** agrees with the following rated value:
400 mV ± 1 dB
- Without adjusting the output setting from step 3-2, use the attenuator to further attenuate the input signal by 20 dB and record signals of 50 Hz, 100 Hz, 300 Hz, 500 Hz, 3 kHz, 10 kHz and 12.5 kHz.
- Playback the recorded signals and, using the 1kHz playback output as a reference (0 dB), confirm that the output between **TP3 / TP4** and **TP5** confirms to the overall frequency response shown in Fig. 11.
- Insert first a blank Chrome-type tape (QZZCRX) and then a blank Metal-type tape (QZZCRZ) into Deck 2.
- Repeat steps 3-5 and 3-6 for each tape and confirm that the output for each conforms to the overall frequency response shown in Fig. 12.

Normal Overall frequency response chart (NR OUT)

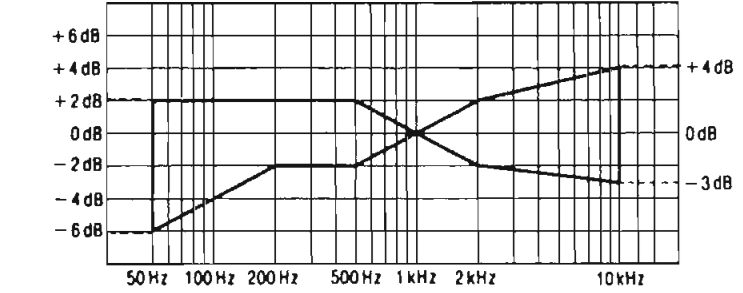

Fig. 11

CrO2 Metal Overall frequency response chart (NR OUT)

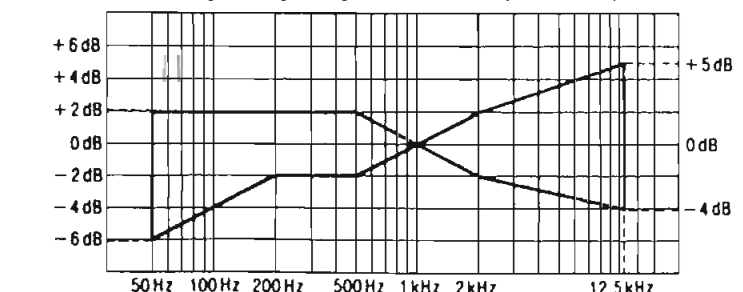
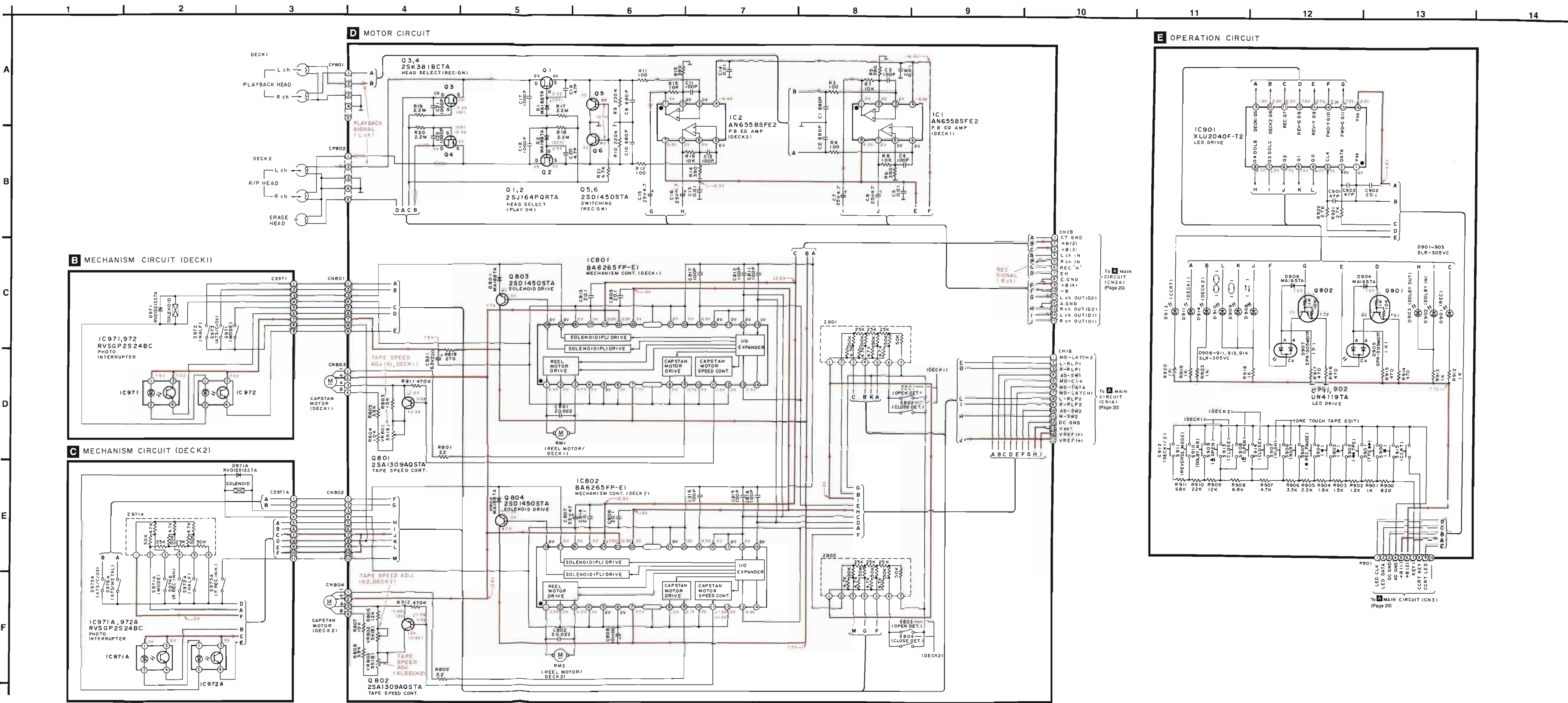
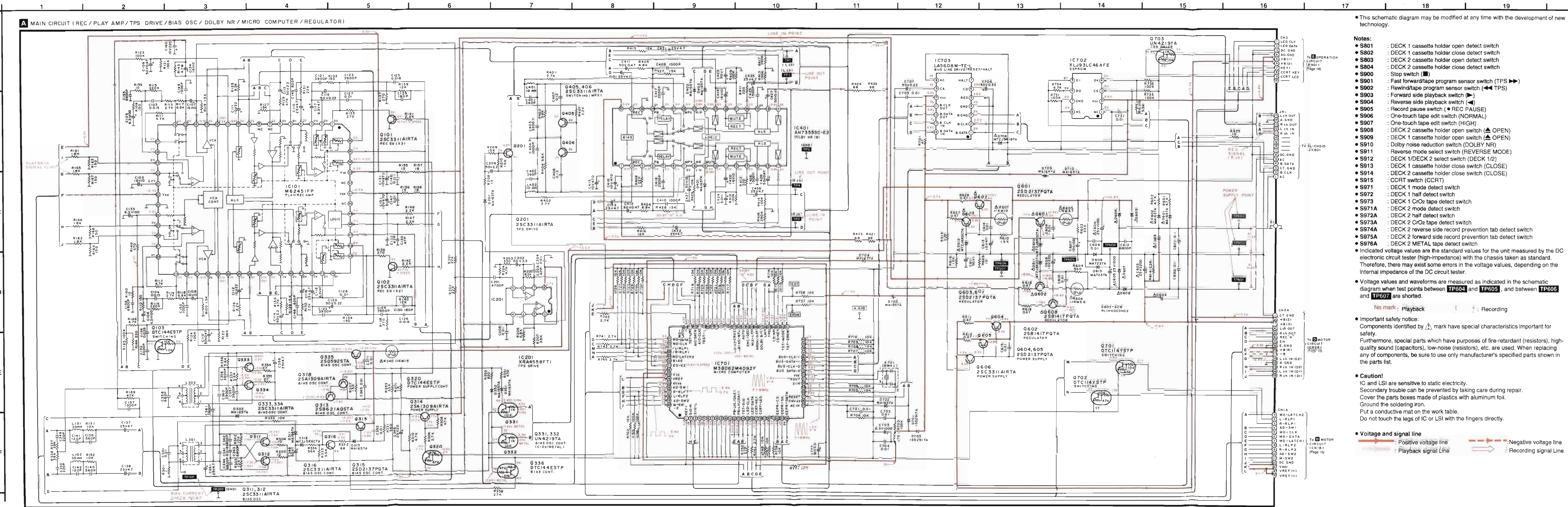

Fig. 12

Schematic Diagram Mechanism (DECK 1), (DECK 2)/Mortor Control/Operation circuit (Parts list on Page 33~36)





● This schematic diagram may be modified at any time with the development of new technology.

- Notes:**
- S801 : DECK 1 cassette holder open detect switch
 - S802 : DECK 1 cassette holder close detect switch
 - S803 : DECK 2 cassette holder open detect switch
 - S804 : DECK 2 cassette holder close detect switch
 - S900 : Stop switch (■)
 - S901 : Fast forward/tape program sensor switch (TPS ▶)
 - S902 : Rewind/tape program sensor switch (◀ TPS)
 - S903 : Forward side playback switch (▶)
 - S904 : Reverse side playback switch (◀)
 - S905 : Record pause switch (● REC PAUSE)
 - S906 : One-touch tape edit switch (NORMAL)
 - S907 : One-touch tape edit switch (HIGH)
 - S908 : DECK 2 cassette holder open switch (▲ OPEN)
 - S909 : DECK 1 cassette holder open switch (▲ OPEN)
 - S910 : Dolby noise reduction switch (DOLBY NR)
 - S911 : Reverse mode select switch (REVERSE MODE)
 - S912 : DECK 1/DECK 2 select switch (DECK 1/2)
 - S913 : DECK 1 cassette holder close switch (CLOSE)
 - S914 : DECK 2 cassette holder close switch (CLOSE)
 - S915 : CCRT switch (CCRT)
 - S917 : DECK 1 mode detect switch
 - S918 : DECK 1 half detect switch
 - S919 : DECK 1 CrO2 tape detect switch
 - S919A : DECK 2 mode detect switch
 - S919B : DECK 2 half detect switch
 - S919C : DECK 2 CrO2 tape detect switch
 - S919D : DECK 2 reverse side record prevention tab detect switch
 - S919E : DECK 2 forward side record prevention tab detect switch
 - S919F : DECK 2 METAL tape detect switch

● Indicated voltage values are the standard values for the unit measured by the DC electronic circuit tester (high-impedance) with the chassis taken as standard. Therefore, there may exist some errors in the voltage values, depending on the internal impedance of the DC circuit tester.

● Voltage values and waveforms are measured as indicated in the schematic diagram when test points between TP604 and TP605, and between TP606 and TP607 are shorted.

No mark : Playback () : Recording

● Important safety notice: Components identified by ▲ mark have special characteristics important for safety. Furthermore, special parts which have purposes of fire-retardant (resistors), high-quality sound (capacitors), low-noise (resistors), etc. are used. When replacing any of components, be sure to use only manufacturer's specified parts shown in the parts list.

● Caution! IC and LSI are sensitive to static electricity. Secondary trouble can be prevented by taking care during repair. Cover the parts boxes made of plastics with aluminum foil. Ground the soldering iron. Put a conductive mat on the work table. Do not touch the legs of IC or LSI with the fingers directly.

● Voltage and signal line

Printed Circuit Board Diagram

• This circuit board diagram may be modified at any time with the development of new technology.

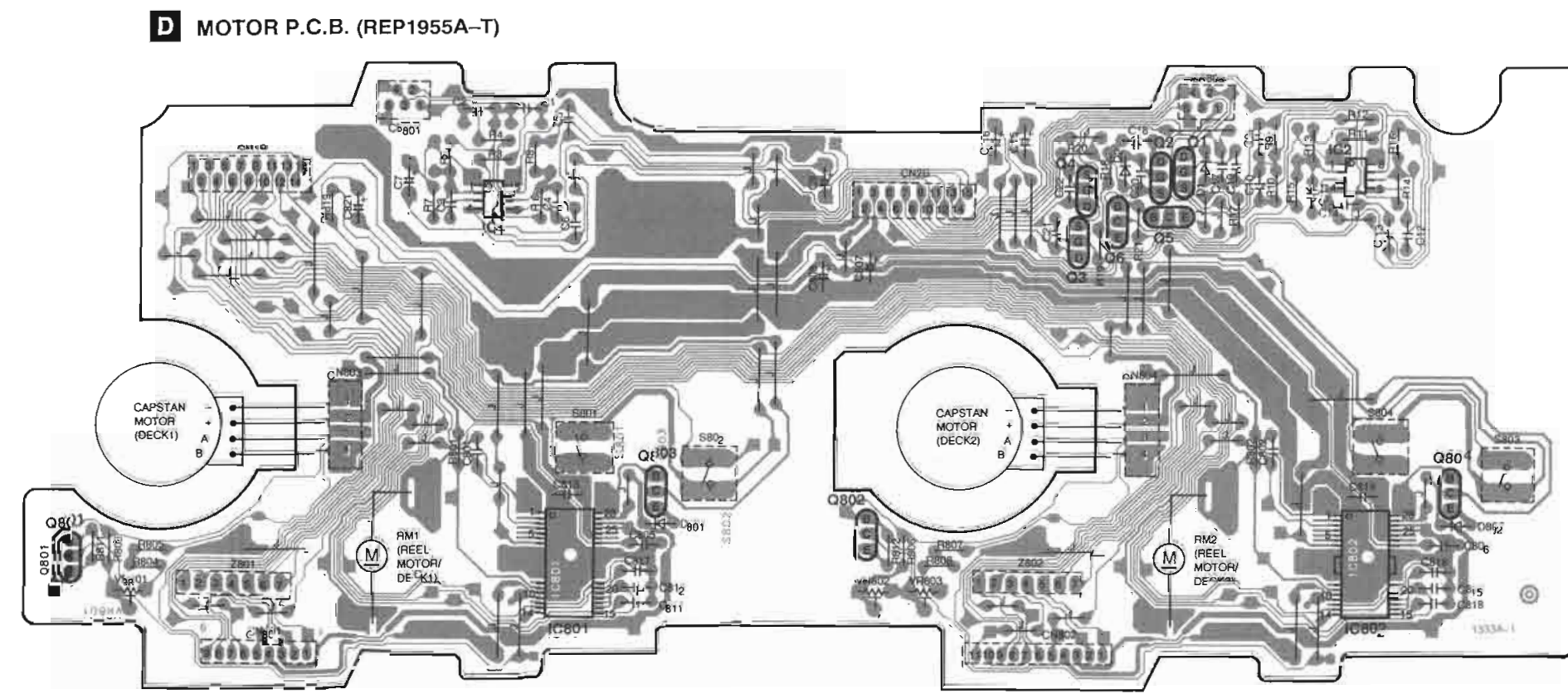
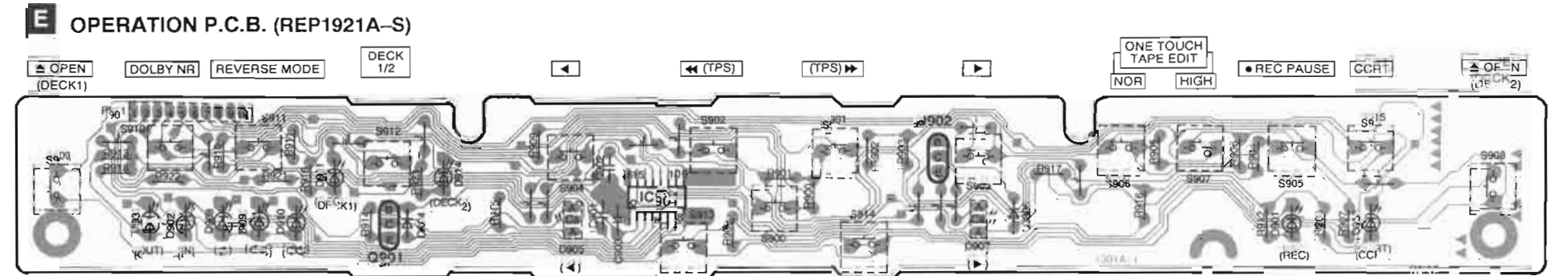
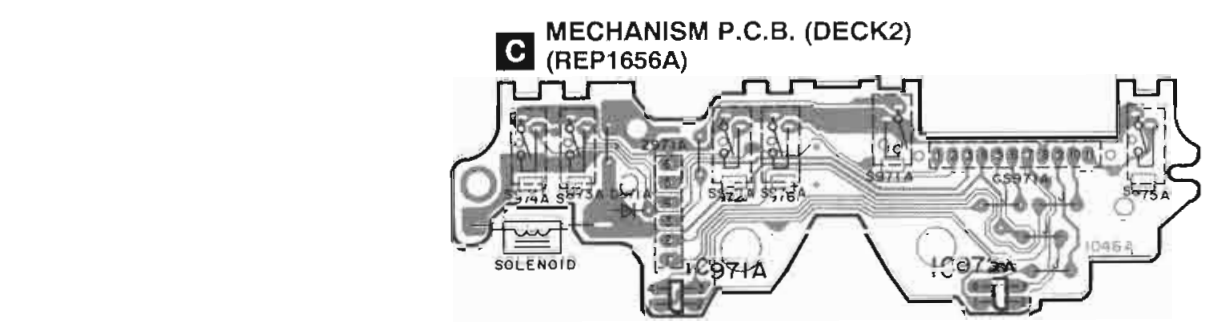
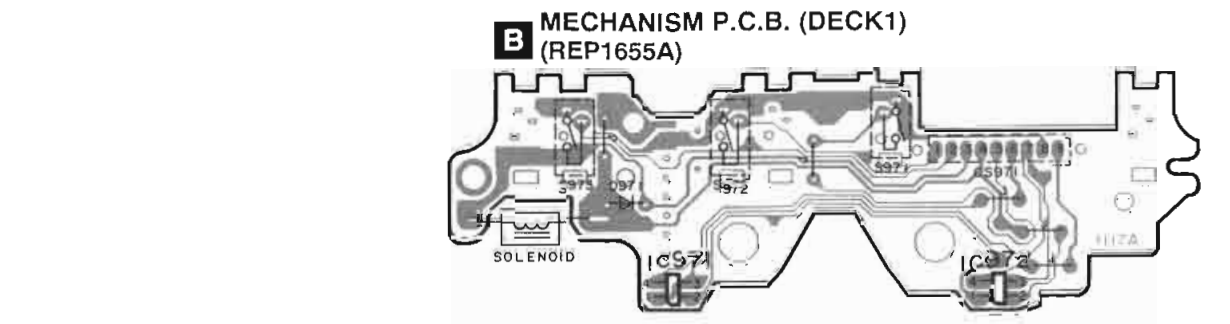
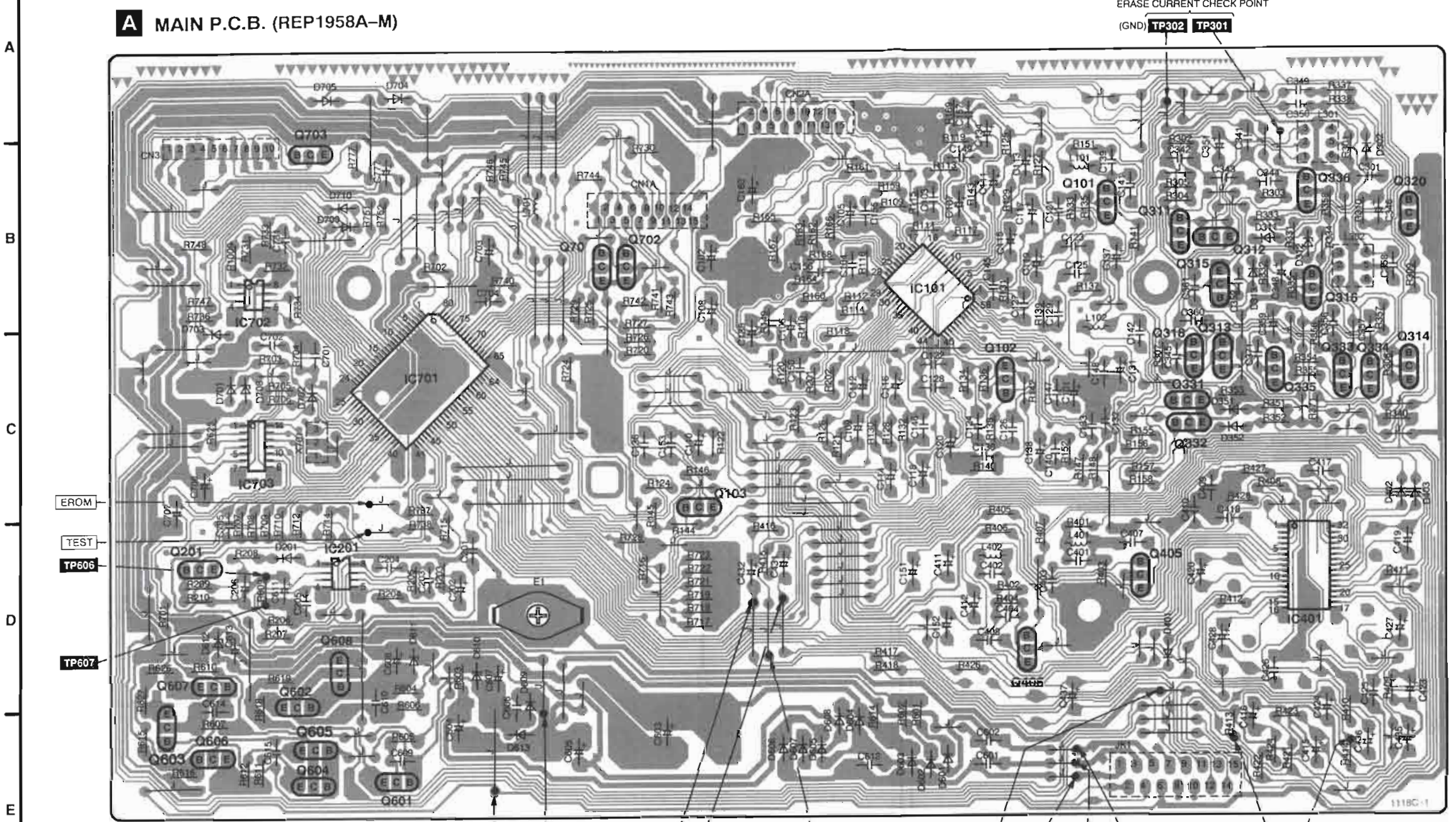

Terminal Guide of IC's, Transistors and Diodes

XRA4558FT1 XLJ93LC46AFE	LA5608M-TE-L 14Pin XLU2040F-T1 16Pin AN7355SC-E2 32Pin AN6558SFE2 8Pin	M62451FP 56Pin M38062M4092F 80Pin	BA6265FP-E1
RVSGP2S24BC	DTC114YSTP DTC144ESTP	UN4219TA 2SA1309AIRTA 2SA1309A-R 2SC3311AIRTA 2SD1450RTA UN4119	2SB621AQSTA 2SD592NCR 2SD2137PQTA
2SB1417PQTA	2SJ164PORTA	2SK381BCDTA	1SS291TA
MA185 MA188TA MA723TA FVD1SS133TA	MTZJ5R1BTA MTZJ5R6CTA MTZJ6R2CTA MTZJ8R2CTA	RL1N4003N02	SPR-305MDTF SLR-305VC

Wiring Connection Diagram

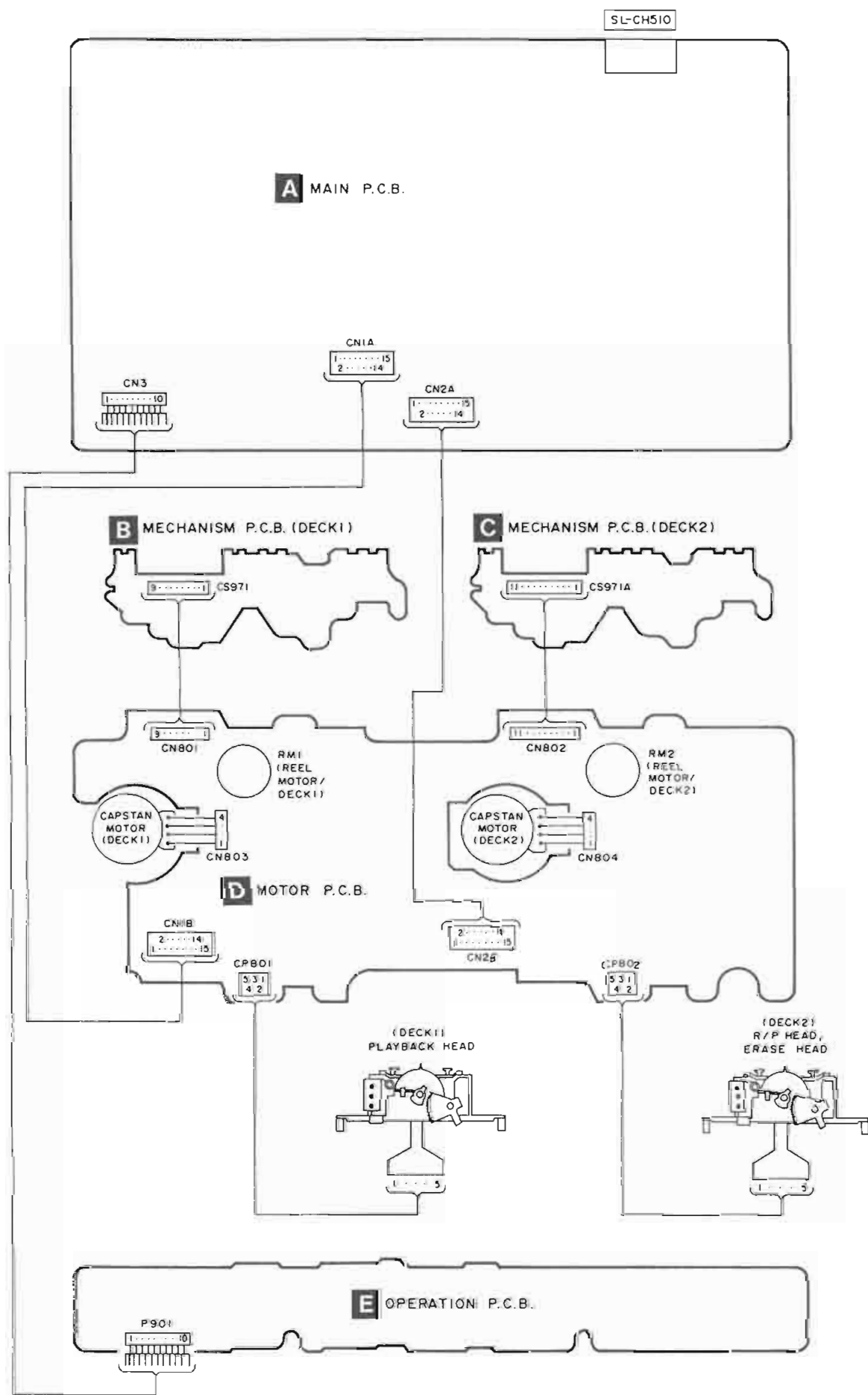

Block Diagram

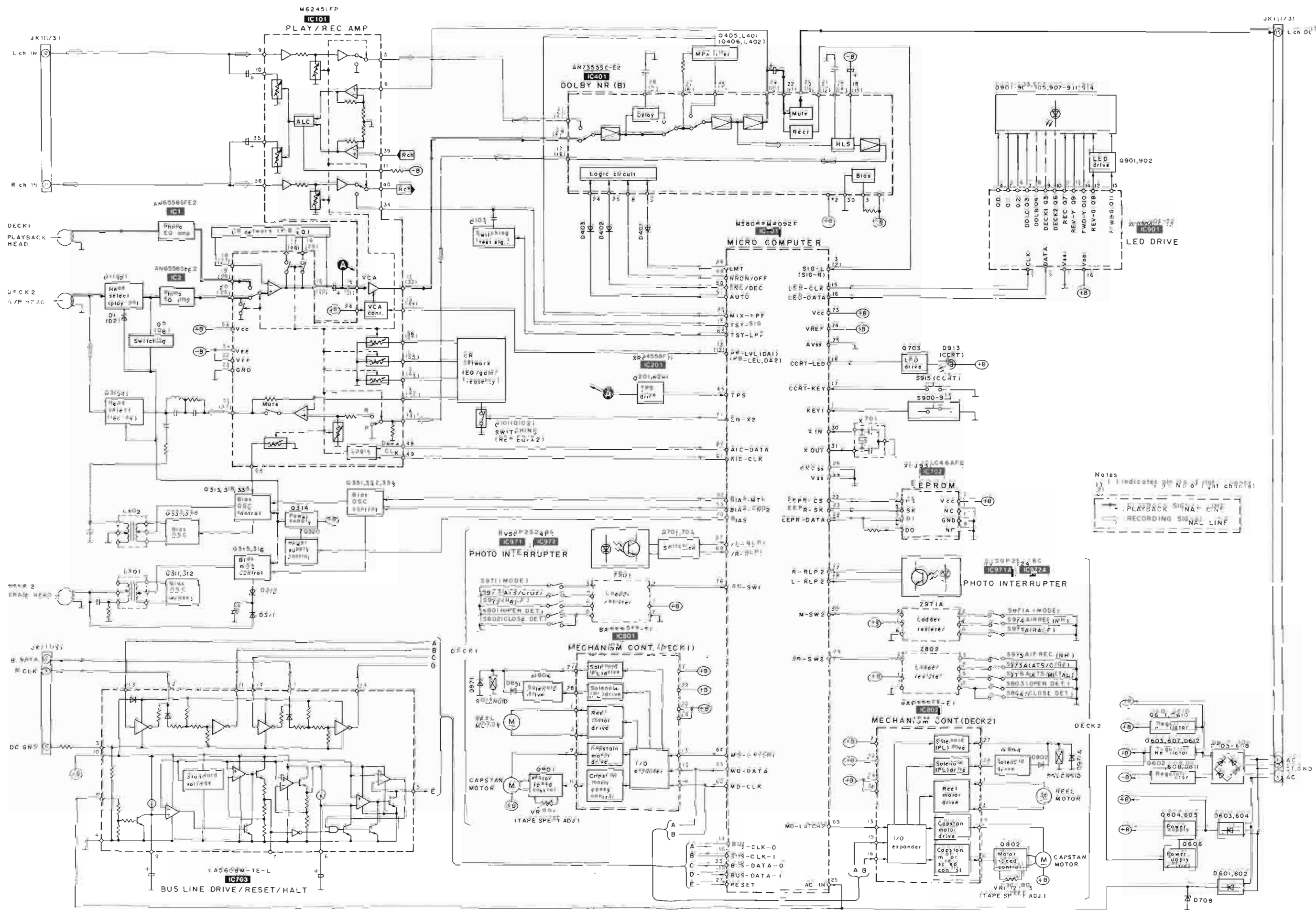

Self-Check Function

This unit incorporates a cassette mechanism self-check function using the DOLBY NR/REVERSE MODE LED indicators. Use this function during maintenance to check for faults in the items below.

● Cassette tapes to be prepared

Metal tape: Recorded music tape with erase-prevention tab intact on one side removed from the other side (use middle portion of tape).

Normal tape: } Recorded music tape with both erase-prevention tabs intact (use middle portion of tape).
CrO₂ tape: }

● Selecting Self-Check Mode

- Turn on the power to the unit. (If RS-CH510 unit is removed from system, turn on power according to procedure on page 9.)
- Check that no tape is inserted in the cassette deck.
Press and hold the DOLBY NR button for about 2 seconds, then press the STOP button for about 2 seconds. (Self-Check mode cannot be selected with a tape loaded in the cassette deck.)

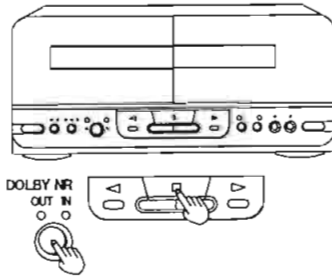

- DOLBY NR and REVERSE MODE LED indicators turn off, and the LED indicator for either Deck 1 or Deck 2 flashes, indicating the self-check mode has been activated.

● Deck 1 Mechanism Check

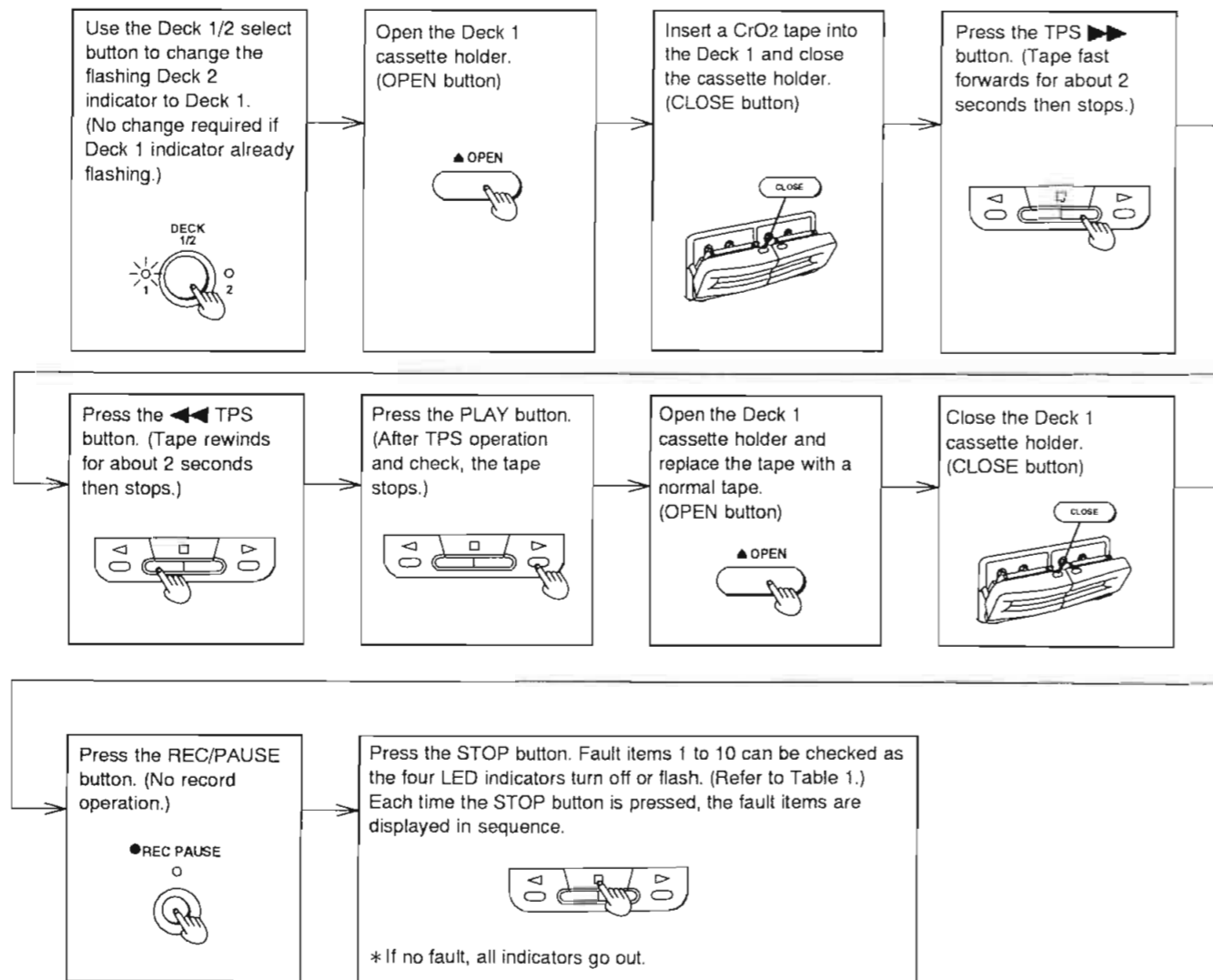

No.	LED indicator status (off/flashing)				Fault location
	DOLBY NR	REVERSE MODE			
	IN	←→	↺	↻	
1.	—	—	—	●	MODE detect switch
2.	—	—	●	—	REC prevention switch
3.	—	—	●	●	Half detect switch
4.	—	●	—	—	Deck OPEN switch
5.	—	●	—	●	Deck CLOSE switch
6.	—	●	●	—	CrO ₂ tape detect switch
7.	—	●	●	●	Metal tape detect switch
8.	●	—	—	—	Reel pulse detect system (Hall IC, etc.)
9.	●	—	—	●	TPS operation
10.	●	—	●	—	Reel motor

Table 1: Self-Check Mode Diagnostic Items

Notes:
 "●": Flashing
 "—": off
 * If no fault, all indicators go out.

● Deck 2 Mechanism Check

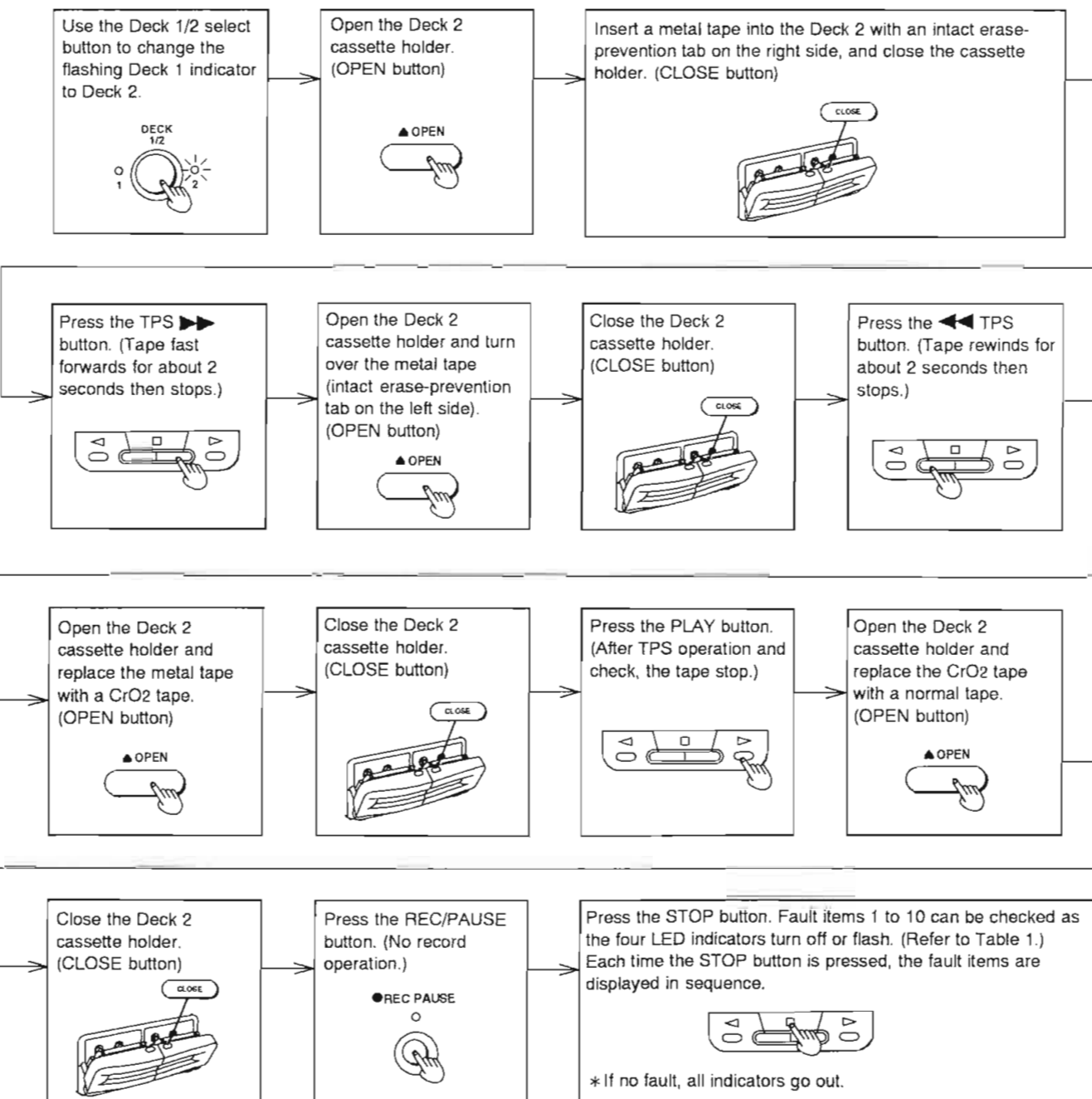

● Exiting Self-Check Mode

- Press the STOP button for more than 5 seconds. (Diagnostic contents stored in memory for both Deck 1 and 2 are erased.)

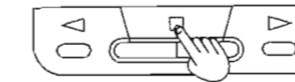

- Remove the cassette tape from the cassette holder.
- Turn off the unit.

Function of IC Terminals

● IC702 (XLJ93LC46AFE)

Pin No.	Terminal Name	I/O	Function
1	NC	—	Connected to GND
2	V _{cc}	I	Power input
3	CS	I	Chip select signal input
4	SK	I	Serial clock input
5	DI	I	Serial data input
6	DO	O	Serial data output
7	GND	—	GND
8	NC	—	Connected to GND

● IC801 and IC802 (BA6265FP-E1)

Pin No.	Terminal Name	I/O	Function
1	RM-	O	Reel motor control (-)
2	GND	—	Reel motor GND
3	RM+	O	Reel motor control (+)
4	NC	—	Connected to GND
6	NC	—	Connected to GND
7	7.5 V	I	Power input (7.5 V)
8	GND	—	Capstan motor GND
9	CPM	O	Capstan motor control
10	NC	—	Connected to GND
11	CPM-SW	O	Capstan motor speed control
12	NC	—	Connected to GND
13	LACH	I	I/O expander lach signal output
14	S.O.	O	I/O expander serial output
15	DATA	I	I/O expander data input
16	CLK	I	I/O expander clock input
17, 18	NC	—	Connected to CLK
19	NC	—	Connected to LACH
20, 21	GND	—	GND
22	5 V	I	Power input (5 V)
23, 24	15 V	I	Power input (15 V)
25	NC	—	Connected to GND
26	GND	—	GND
27	PL15 V	O	Plunger drive signal output (15 V)
28	PL7.5 V	O	Plunger drive signal output (7.5 V)

● IC701 (M38062M4092F)

Pin No.	Terminal Name	I/O	Function
1	KEY1	I	Operation key input
2	SIG-R	I	Level detection input for audio signal (R-ch)
3	SIG-L	I	Level detection input for audio signal (L-ch)
4 11	—	—	Unused, connected to GND
12	PB-LVL (DA2)	O	Control signal output for playback level (R-ch)
13	PB-LVL (DA1)	O	Control signal output for playback level (L-ch)
14	TST-SIG	O	Audio test signal output (400 Hz/10 kHz)
15	LED-CLK	O	Serial clock signal output for LED drive control to IC901
16	LED-DATA	O	Serial data signal output for LED drive control to IC901
17	CCRT-KEY	I	Key input for CCRT
18	CCRT-LED	O	ON/OFF control signal output for CCRT display to LED
19 21	—	—	Unused, connected to GND
22	EEPR-CS	O	Chip select signal output for EEPROM
23	EEPR-SK	O	Serial clock signal output for EEPROM
24	EEPR-DATA	I/O	Serial data signal input/output for EEPROM
25	ACIN	I	Signal input for power OFF mode detection
26	CNVSS	—	Connected to Vss
27	/RESET	I	Reset signal input from IC703
28 29	—	—	Unused, connected to GND
30	XIN	I	Connected to a oscillator X701 (8 MHz)
31	XOUT	O	
32	VSS	—	Connected to GND
33	BUS DATA-0	O	Bus data signal output
34	BUS CLK-0	O	Bus clock signal output
35	BUS DATA-1	I	Bus data signal input
36	BUS CLK-1	I	Bus clock signal input
37 40	—	—	Unused, connected to GND
41	TST-EPROM	I	Signal input for EEPROM initialization
42	TST-MODE	I	Switching signal input for Test ON/OFF mode
43	CS-KEY	I	Connected to GND
44	CS-NR	I	Model selection input (This unit ; "L")
45	TPS	I	Detection signal input for tape music search presence signal in TPS operation

Pin No.	Terminal Name	I/O	Function
46	LMT	O	Muting signal output for line out
47	DOLBY B/C	O	Dolby B/C switching signal output
48	NR ON/OFF	O	Dolby ON/OFF switching signal output
49	MIX-LPF	O	Filter ON/OFF switching signal output in audio signal level detection
50	ENC/DEC	O	Encoder/decoder switching signal
51	AUTO	O	Gain control signal output for audio signal level detection circuit
52	BIAS-MTL	O	Control signal output for recording bias in use of a metal tape
53	BIAS-CRO2	O	Control signal output for recording bias in use of a Chrome tape
54 59	—	—	Unused, connected to GND
60	TEST "L"	O	Connected to GND
61	AIC-CLK	O	Clock control signal output to IC for audio recording/playback
62	AIC-DATA	O	Data control signal output to IC for audio recording/playback
63	TST-LPF	O	Filter ON/OFF switching signal output for CCRT recording test signal (400 Hz: "H")
64	MD LATCH1	O	Latch signal output to IC801 for mechanism drive on deck 1
65	MD-DATA	O	Serial data signal output to mechanism drive ICs (IC801, IC802)
66	MD-CLK	O	Serial clock signal output to mechanism ICs (IC801, 802)
67	/L-RLP1	I	Pulse signal input for rotation detection to left side reel of deck 1
68	/R-RLP1	I	Pulse signal input for rotation detection to right side reel of deck 1
69	MD-LATCH2	O	Latch signal output to IC802 for mechanism drive on deck 2
70	BIAS	O	ON/OFF switching signal output for recording bias
71	EQ-X2	O	Switching signal output for recording equalizer
72	—	—	Unused, connected to GND
73	Vcc	—	Connected to power source (+5V)
74	VREF	—	Connected to reference voltage for A/D input
75	AVSS	—	Connected to GND
76	VREF	—	Standard voltage for A/D convertor (Connected to VCC)
77	R-RLP2	I	Pulse signal input for rotation detection to right side reel of deck 2
78	L-RLP2	I	Pulse signal input for rotation detection to left side reel of deck 2
79	AD-SW2	I	Signal input for mechanism switches for deck 2
80	M-SW2	I	Signal input for mechanism switches for deck 2

Replacement Parts List

Notes: *Important safety notice:

Components identified by Δ mark have special characteristics important for safety.

Furthermore, special parts which have purposes of fire-retardant (resistors), high-quality sound (capacitors), low-noise (resistors), etc. are used.

When replacing any of components, be sure to use only manufacturer's specified parts shown in the parts list.

*The parenthesized indications in the Remarks columns specify the areas. (Refer to the cover page for area.)

Parts without these indications can be used for all areas.

*The "(SF)" mark denotes the standard part.

Ref. No.	Part No.	Part Name & Description	Remarks	Ref. No.	Part No.	Part Name & Description	Remarks
		INTEGRATED CIRCUIT(S)		Q801, 802	2SA1309A-R	TRANSISTOR	
				Q803, 804	2SD1450RTA	TRANSISTOR	
				Q901, 902	UN4119	TRANSISTOR	
						DIODE(S)	
IC1, 2	AN6558SFE2	IC, P. B EQ AMP.		D1, 2	MA188TA	DIODE	
IC101	M62451FP	IC, REC./PLAYBACK AMP.		D201	MA165	DIODE	
IC201	XRA4558FT1	IC, TPS DRIVE		D302	MA165	DIODE	
IC401	AN7355SC-E2	IC, DOLBY NR		D311	MA188TA	DIODE	
IC701	M38062M4092F	IC, MICRO COMPUTER		D312	MTZJ5R6CTA	DIODE	
IC702	XLJ93LC46AFE	IC, EEPROM		D313	MA165	DIODE	
IC703	LA5608M-TE-L	IC, BUS LINE/HALT/RESET		D351, 352	MA165	DIODE	
IC801, 802	BA6265FP-E1	IC, MECHANISM CONTROL		D401-403	MA165	DIODE	
IC901	XLU2040F-T1	IC, LED DRIVE		D601, 602	MA165	DIODE	Δ
IC971	RVSGP2S24BC	PHOTO INTERRUPTER(DECK1)		D603-608	RL1N4003N02	DIODE	Δ
IC971A	RVSGP2S24BC	PHOTO INTERRUPTER(DECK2)		D609	MA723TA	DIODE	
IC972	RVSGP2S24BC	PHOTO INTERRUPTER(DECK1)		D610, 611	MTZJ8R2CTA	DIODE	Δ
IC972A	RVSGP2S24BC	PHOTO INTERRUPTER(DECK2)		D612	MTZJ6R2CTA	DIODE	Δ
		TRANSISTOR(S)		D613	MA723TA	DIODE	
Q1, 2	2SJ164PQRTA	TRANSISTOR		D701	1SS291TA	DIODE	
Q3, 4	2SK381BCDTA	TRANSISTOR		D702	MA165	DIODE	
Q5, 6	2SD1450RTA	TRANSISTOR		D703	1SS291TA	DIODE	
Q101, 102	2SC3311A1RTA	TRANSISTOR		D704, 705	MA165	DIODE	
Q103	DTC144ESTP	TRANSISTOR		D708	MTZJ5R1BTA	DIODE	Δ
Q201	2SC3311A1RTA	TRANSISTOR		D709, 710	MA165	DIODE	
Q311, 312	2SC3311A1RTA	TRANSISTOR		D801, 802	MA188TA	DIODE	
Q313	2SB621AQSTA	TRANSISTOR		D901-903	SLR-305VC	LED	
Q314	2SA1309A1RTA	TRANSISTOR		D904	MA165	DIODE	
Q315	2SD2137PQTA	TRANSISTOR		D905	SPR-305MDTF	LED	
Q316	2SC3311A1RTA	TRANSISTOR		D906	MA165	DIODE	
Q318	2SA1309A1RTA	TRANSISTOR		D907	SPR-305MDTF	LED	
Q320	DTC144ESTP	TRANSISTOR		D908-911	SLR-305VC	LED	
Q331, 332	UN4219TA	TRANSISTOR		D913, 914	SLR-305VC	LED	
Q333, 334	2SC3311A1RTA	TRANSISTOR		D971	RVD1SS133TA	DIODE (DECK1)	
Q335	2SD592NCR	TRANSISTOR		D971A	RVD1SS133TA	DIODE (DECK2)	
Q336	DTC144ESTP	TRANSISTOR				VARIABLE RESISTOR(S)	
Q405, 406	2SC3311A1RTA	TRANSISTOR		VR801	EVNDCAA03B53	TAPE SPEED ADJ (DECK1) NORMAL	
Q601	2SD2137PQTA	TRANSISTOR	Δ	VR802	EVNDCAA03B53	TAPE SPEED ADJ (DECK2) HIGH	
Q602	2SB1417PQTA	TRANSISTOR	Δ	VR803	EVNDCAA03B53	TAPE SPEED ADJ (DECK2) NORMAL	
Q603	2SD2137PQTA	TRANSISTOR	Δ			COMPONENT COMBINATION(S)	
Q604, 605	2SD2137PQTA	TRANSISTOR		Z801, 802	EXBF7L355SYV	COMPONENT COMBINATION	
Q606	2SC3311A1RTA	TRANSISTOR					
Q607	2SD2137PQTA	TRANSISTOR	Δ				
Q608	2SB1417PQTA	TRANSISTOR	Δ				
Q701, 702	DTC114YSTP	TRANSISTOR					
Q703	UN4219TA	TRANSISTOR					

Ref. No.	Part No.	Part Name & Description	Remarks	Ref. No.	Part No.	Part Name & Description	Remarks
Z971A	EXBF6L306SYV	COMPONENT COMBINATION		CN801	RJT071H09A	CONNECTOR(9P)	
		COIL(S)		CN802	RJT071H11A	CONNECTOR(11P)	
				CN803, 804	RJR0113	CONNECTOR(MOTOR)	
				CS971	RJU071H09M	SOCKET(9P)	
L101, 102	SLQX303-1KT	COIL		CS971A	RJU071H11M	SOCKET(11P)	
L301, 302	SL09B4-K	COIL		CP801, 802	RJS2A0205-2S	SOCKET(5P)	
L401, 402	RLQB103JT-Y	COIL				GND PLATE	
L701	RLQA100JT-Y	COIL					
		OSCILLATOR(S)		E1	SNE1004-2	GND PLATE	
						JACK	
X701	EFOEC8004T4	OSCILLATOR(8MHz)					
		SWITCH(ES)		JK1	RJT065K15	SYSTEM CONNECTOR	
S801	RSH1A024-U	SW, HOLDER OPEN DET. (DECK1)					
S802	RSH1A024-U	SW, HOLDER CLOSE DET. (DECK1)					
S803	RSH1A024-U	SW, HOLDER OPEN DET. (DECK2)					
S804	RSH1A024-U	SW, HOLDER CLOSE DET. (DECK2)					
S900	EVQ21405R	SW, STOP					
S901	EVQ21405R	SW, FF (TPS)					
S902	EVQ21405R	SW, REW (TPS)					
S903	EVQ21405R	SW, FWD PLAY					
S904	EVQ21405R	SW, REV PLAY					
S905	EVQ21405R	SW, REC PAUSE					
S906	EVQ21405R	SW, TAPE EDIT (NORMAL)					
S907	EVQ21405R	SW, TAPE EDIT (HIGH)					
S908	EVQ21405R	SW, HOLDER OPEN (DECK2)					
S909	EVQ21405R	SW, HOLDER OPEN (DECK1)					
S910	EVQ21405R	SW, DOLBY NR					
S911	EVQ21405R	SW, REVERSE MODE					
S912	EVQ21405R	SW, DECK1/2 SELECT					
S913	EVQ21405R	SW, HOLDER CLOSE (DECK1)					
S914	EVQ21405R	SW, HOLDER CLOSE (DECK2)					
S915	EVQ21405R	SW, CCKT					
S971	RSH1A018-U	SW, MODE (DECK1)					
S971A	RSH1A018-U	SW, MODE (DECK2)					
S972	RSH1A019-U	SW, HALF (DECK1)					
S972A	RSH1A019-U	SW, HALF (DECK2)					
S973	RSH1A019-U	SW, ATS/CrO2 (DECK1)					
S973A	RSH1A019-U	SW, ATS/CrO2 (DECK2)					
S974A	RSH1A019-U	SW, R. REC. 1NH (DECK2)					
S975A	RSH1A019-U	SW, F. REC. 1NH (DECK2)					
S976A	RSH1A019-U	SW, ATS/METAL (DECK2)					
		CONNECTOR(S)					
CN1A	RJS1A6815	SOCKET (15P)					
CN2A	RJS1A6815	SOCKET (15P)					
CN1B	RJS1A6715-Q	SOCKET (15P)					
CN2B	RJS1A6715-Q	SOCKET (15P)					
CN3	RJS10T4ZA	SOCKET (10P)					

Notes : * Capacity values are in microfarads (uF) unless specified otherwise, P=Pico-farads (pF) F=Farads (F)
 * Resistance values are in ohms, unless specified otherwise, 1K=1,000(OHM) , 1M=1,000k(OHM)

Ref. No.	Part No.	Values & Remarks	Ref. No.	Part No.	Values & Remarks	Ref. No.	Part No.	Values & Remarks
		RESISTORS	R208	ERDS2TJ102	1/4W 1K	R625	ERDS2TJ100	1/4W 10
			R209, 210	ERDS2TJ153	1/4W 15K	R626, 627	ERDS2TJR47T	1/4W 0.47
			R301	ERDS2TJ1R0	1/4W 1.0	R701	ERDS2TJ470	1/4W 47
R3, 4	ERDS2TJ101	1/4W 100	R302, 303	ERDS2TJ103	1/4W 10K	R702	ERDS2TJ103	1/4W 10K
R5, 6	ERDS2TJ391	1/4W 390	R304, 305	ERDS2TJ100	1/4W 10	R703	ERDS2TJ104	1/4W 100K
R7, 8	ERDS2TJ103	1/4W 10K	R307	ERDS2TJ153	1/4W 15K	R704-710	ERDS2TJ103	1/4W 10K
R9	ERDS2TJ224T	1/4W 220K	R308	ERDS2TJ473	1/4W 47K	R712	ERDS2TJ103	1/4W 10K
R10	ERDS2TJ224T	1/4W 220K	R309	ERDS2TJ272T	1/4W 2.7K	R714-730	ERDS2TJ103	1/4W 10K
R11, 12	ERDS2TJ101	1/4W 100	R310	ERDS2TJ472	1/4W 4.7K	R731-733	ERDS2TJ104	1/4W 100K
R13, 14	ERDS2TJ391	1/4W 390	R331	ERDS2TJ561	1/4W 560	R734	ERDS2TJ472	1/4W 4.7K
R15, 16	ERDS2TJ103	1/4W 10K	R332	ERDS2TJ680T	1/4W 68	R736-738	ERDS2TJ103	1/4W 10K
R17-20	ERDS2TJ225	1/4W 2.2M	R333	ERDS2TJ103	1/4W 10K	R740	ERDS2TJ103	1/4W 10K
R21	ERDS2TJ472	1/4W 4.7K	R334	ERDS2TJ563	1/4W 56K	R741-744	ERDS2TJ272T	1/4W 2.7K
R109, 110	ERDS2TJ151	1/4W 150	R335	ERDS2TJ562	1/4W 5.6K	R745, 746	ERDS2TJ104	1/4W 100K
R111, 112	ERDS2TJ472	1/4W 4.7K	R337, 338	ERDS2TJ393	1/4W 39K	R747, 748	ERDS2TJ103	1/4W 10K
R113, 114	ERDS2TJ272T	1/4W 2.7K	R340	ERD2FCVJ150T	1/4W 15 Δ	R751, 752	ERDS2TJ272T	1/4W 2.7K
R115, 116	ERDS2TJ224T	1/4W 220K	R351	ERDS2TJ471	1/4W 470	R777	ERDS2TJ103	1/4W 10K
R117, 118	ERDS2TJ682T	1/4W 6.8K	R352	ERDS2TJ821	1/4W 820	R801, 802	ERDS2TJ2R2T	1/4W 2.2
R119, 120	ERDS2TJ152	1/4W 1.5K	R353	ERDS2TJ333	1/4W 33K	R803	ERDS2TJ153	1/4W 15K
R121-124	ERDS2TJ104	1/4W 100K	R354, 355	ERDS2TJ270T	1/4W 27	R804	ERDS2TJ103	1/4W 10K
R125, 126	ERDS2TJ622	1/4W 8.2K	R356, 357	ERDS2TJ562	1/4W 5.6K	R805	ERDS2TJ392T	1/4W 3.9K
R127, 128	ERDS2TJ153	1/4W 15K	R358	ERDS2TJ272T	1/4W 2.7K	R806	ERDS2TJ123	1/4W 12K
R129, 130	ERDS2TJ473	1/4W 47K	R371	ERDS2TJ102	1/4W 1K	R807	ERDS2TJ103	1/4W 10K
R131, 132	ERDS2TJ223	1/4W 22K	R401, 402	ERDS2TJ272T	1/4W 2.7K	R808	ERDS2TJ392T	1/4W 3.9K
R133, 134	ERDS2TJ151	1/4W 150	R403, 404	ERDS2TJ562	1/4W 5.6K	R811, 812	ERDS2TJ474	1/4W 470K
R135-138	ERDS2TJ271	1/4W 270	R405, 406	ERDS2TJ682T	1/4W 6.8K	R819	ERDS2TJ271	1/4W 270
R139, 140	ERDS2TJ123	1/4W 12K	R407	ERDS2TJ222	1/4W 2.2K	R900	ERDS2TJ821	1/4W 820
R141, 142	ERDS2TJ222	1/4W 2.2K	R408	ERDS2TJ223	1/4W 22K	R901	ERDS2TJ102	1/4W 1K
R143	ERDS2TJ475T	1/4W 4.7M	R409, 410	ERDS2TJ104	1/4W 100K	R902	ERDS2TJ122	1/4W 1.2K
R144	ERDS2TJ331	1/4W 330	R411, 412	ERDS2TJ221	1/4W 220	R903	ERDS2TJ152	1/4W 1.5K
R145	ERDS2TJ104	1/4W 100K	R413, 414	ERDS2TJ104	1/4W 100K	R904	ERDS2TJ182	1/4W 1.8K
R146	ERDS2TJ472	1/4W 4.7K	R415, 416	ERDS2TJ123	1/4W 12K	R905	ERDS2TJ222	1/4W 2.2K
R147, 148	ERDS2TJ222	1/4W 2.2K	R417, 418	ERDS2TJ394	1/4W 390K	R906	ERDS2TJ332	1/4W 3.3K
R149	ERDS2TJ471	1/4W 470	R421-424	ERDS2TJ680T	1/4W 68	R907	ERDS2TJ472	1/4W 4.7K
R151, 152	ERDS2TJ103	1/4W 10K	R426	ERDS2TJ103	1/4W 10K	R908	ERDS2TJ682T	1/4W 6.8K
R155, 156	ERDS2TJ150T	1/4W 15	R427, 428	ERDS2TJ153	1/4W 15K	R909	ERDS2TJ123	1/4W 12K
R157, 158	ERDS2TJ180T	1/4W 18	R601, 602	ERDS2TJ472	1/4W 4.7K	R910	ERDS2TJ223	1/4W 22K
R159, 160	ERDS2TJ100	1/4W 10	R603	ERDS2TJ331	1/4W 330	R911	ERDS2TJ683	1/4W 68K
R161, 162	ERDS2TJ182	1/4W 1.8K	R604	ERDS2TJ561	1/4W 560	R912, 913	ERDS2TJ102	1/4W 1K
R163, 164	ERDS2TJ151	1/4W 150	R605	ERD2FCVJ4R7T	1/4W 4.7 Δ	R914-917	ERDS2TJ471	1/4W 470
R165, 166	ERDS2TJ182	1/4W 1.8K	R606	ERD2FCVJ5R6T	1/4W 5.6 Δ	R918-920	ERDS2TJ102	1/4W 1K
R167, 168	ERDS2TJ151	1/4W 150	R607	ERD2FCVJ100T	1/4W 10 Δ	R921, 922	ERDS2TJ272T	1/4W 2.7K
R169	ERDS2TJ473	1/4W 47K	R609	ERDS2TJ100	1/4W 10	R923	ERDS2TJ102	1/4W 1K
R201, 202	ERDS2TJ223	1/4W 22K	R610	ERDS2TJ152	1/4W 1.5K	R1009	ERDS2TJ332	1/4W 3.3K
R203	ERDS2TJ331	1/4W 330	R611, 612	ERDS2TJR47T	1/4W 0.47			
R204	ERDS2TJ472	1/4W 4.7K	R614	ERDS2TJ222	1/4W 2.2K			CAPACITORS
R205	ERDS2TJ823T	1/4W 82K	R615	ERDS2TJ332	1/4W 3.3K			
R206	ERDS2TJ682T	1/4W 6.8K	R616	ERDS2TJ103	1/4W 10K	C1, 2	ECBA1H681K85	50V 680P
R207	ERDS2TJ393	1/4W 39K	R618, 619	ERDS2TJR47T	1/4W 0.47	C3, 4	ECBT1H101K85	50V 100P

Ref. No.	Part No.	Values & Remarks	Ref. No.	Part No.	Values & Remarks
C5, 6	ECBT1E103ZF	25V 0.01U	C349, 350	ECBT1H221KB5	50V 220P
C7, 8	ECEA1EKA4R7B	25V 4.7U	C351	ECEA1EKA4R7B	25V 4.7U
C9	ECBA1H681KB5	50V 680P	C352	ECBT1E103ZF	25V 0.01U
C10	ECBA1H681KB5	50V 680P	C356, 357	ECKR1H392KB5	50V 3900P
C11, 12	ECBT1H101KB5	50V 100P	C358	ECQP1681JZ3	16V 680P
C13, 14	ECBT1E103ZF	25V 0.01U	C359	ECEA1EKA4R7B	25V 4.7U
C15, 16	ECEA1EKA4R7B	25V 4.7U	C360, 361	ECKR1H392KB5	50V 3900P
C17, 18	ECBT1H102KB5	50V 1000P	C371	ECBT1E103ZF	25V 0.01U
C19, 20	ECBT1H47KC5	50V 4.7P	C401, 402	ECBT1H391KB5	50V 390P
C21, 22	ECBT1H102KB5	50V 1000P	C403, 404	ECBT1C332KR5	16V 3300P
C101	RCE1AM471BV	10V 470U	C407, 408	ECQV1H124JM3	50V 0.12U
C102	ECEA1CKA100B	16V 10U	C409, 410	ECBT1H102KB5	50V 1000P
C103, 104	ECQB1H153JF3	50V 0.015U	C411, 412	ECEA1HKA47B	50V 0.47U
C105, 106	ECEA0JKA101B	6.3V 100U	C415, 416	RCE1AM471BV	10V 470U
C107, 108	ECEA1CKA100B	16V 10U	C417, 418	ECQB1H222JF3	50V 2200P
C109, 110	ECEA1HKA47B	50V 0.47U	C419, 420	ECEA1CKA100B	16V 10U
C111, 112	ECEA1AKA220B	10V 22U	C423, 424	ECEA1HKA010B	50V 1U
C113, 114	ECEA1HKA2R2B	50V 2.2U	C425, 426	ECQB1H152JF3	50V 1500P
C115, 116	ECEA1EKA4R7B	25V 4.7U	C427, 428	ECEA1HKA47B	50V 0.47U
C117, 118	ECEA0JKA470B	6.3V 47U	C431, 432	ECEA1EKA4R7B	25V 4.7U
C119, 120	ECEA1HKA22B	50V 0.22U	C435, 436	ECEA1EKA4R7B	25V 4.7U
C121-124	ECQB1H392JF3	50V 3900P	C437	ECEA1HKA100B	50V 10U
C125, 126	ECQB1H183JF3	50V 0.018U	C601, 602	ECFR1H1042F	50V 0.1U
C127, 128	ECQB1H103JF3	50V 0.01U	C603	ECEA1EJ222B	25V 2200U Δ
C129, 130	ECBT1H181KB5	50V 180P	C604, 605	ECA1EM102B	25V 1000U Δ
C131	RCE1AM471BV	10V 470U	C606	ECBT1E103ZF	25V 0.01U
C132, 133	ECBT1H470J5	50V 47P	C607	ECEA1AKA101B	10V 100U
C134	ECEA1CKA100B	16V 10U	C608	ECEA1AKA221B	10V 220U
C135	ECEA0JKA101B	6.3V 100U	C609, 610	ECBT1E103ZF	25V 0.01U
C136	ECQB1H393JF3	50V 0.039U	C611	ECEA1HKA010B	50V 1U
C137, 138	ECEA1EKA4R7B	25V 4.7U	C612	ECKR2H682PE	500V 6800P
C139, 140	ECBT1H561KB5	50V 560P	C613	ECEA1AU470	10V 47U
C141, 142	ECKR2H121KB5	500V 120P	C614, 615	ECBT1E103ZF	25V 0.01U
C145, 146	ECQB1H821JF3	50V 820P	C701, 702	ECBT1E103ZF	25V 0.01U
C147, 148	ECBT1E103ZF	25V 0.01U	C703	ECEA0JU102	6.3V 1000U
C149, 150	ECBT1H102KB5	50V 1000P	C704, 705	ECBT1E103ZF	25V 0.01U
C151, 152	ECEA1EKA4R7B	25V 4.7U	C706	ECEA1HKA33B	50V 0.33U
C153	ECQB1H332JF3	50V 3300P	C707	ECEA1HKA22B	50V 0.22U
C155, 156	ECBT1C682KR5	16V 6800P	C731	ECBT1E103ZF	25V 0.01U
C157	ECBT1H102KB5	50V 1000P	C777	ECEA1HKA3R3B	50V 3.3U
C160	ECEA1AKA221B	10V 220U	C801, 802	ECBT1E223ZF	25V 0.022U
C201	ECQB1H472JF3	50V 4700P	C805, 806	ECBT1H1042F5	50V 0.1U
C202	ECEA1HKA3R3B	50V 3.3U	C807	ECEA1VKA470B	35V 47U
C203	ECBT1H470J5	50V 47P	C808	ECEA1AKA101B	10V 100U
C204, 205	ECBT1E103ZF	25V 0.01U	C811, 812	ECBT1H101KB5	50V 100P
C206	ECEA1HKA2R2B	50V 2.2U	C813, 814	ECBT1H1042F5	50V 0.1U
C301	ECQP1103JZ3	100V 0.01U	C815-818	ECBT1H101KB5	50V 100P
C341	ECFR1E183KR	25V 0.018U	C821	ECEA0JKA221B	6.3V 220U
C342-344	ECKD1H682KB	50V 6800P	C901	ECBT1H470J5	50V 47P
C345	ECBT1E103ZF	25V 0.01U	C902	ECBT1H1042F5	50V 0.1U
C346	ECEA1EKA220B	25V 22U	C903	ECBT1H470J5	50V 47P
C348	ECEA1HKA010B	50V 1U			

Ref. No.	Part No.	Part Name & Description	Remarks	Ref. No.	Part No.	Part Name & Description	Remarks
				112	RMB0264	SPRING	
				113	RJW147ZA	SPRING	
		CABINET PARTS		114	RML0267A	LEVER	
				115	RML0268A	LEVER	
1	RKMD265-K	CABINET		116	RMM0091A	BRAKE ROD	
2	RGP0409-K	FRONT PANEL		117	RMS0398-1	PLUNGER	
3	RFKJSCH404EK	BOTTOM BOARD ASS'Y		118	RSJ0003	SOLENOID	
3-1	AKA0011-3	FOOT		119	RJS6092C	SPRING	
4	RGR0198A-A	REAR PANEL		120	RXG0036	REEL TABLE GEAR	
5	RYF0287A-K	CASSETTE LID ASS'Y (DECK1)		121	RXJ0106	IDLER LEVER	
5-1	RGU0958B-K	BUTTON (CLOSE)		122	RXP0052	PINCH ROLLER (F) ASS'Y	
5-2	RMM0122	LOD		122-1	RMB0259	SPRING	
6	RYF0288-K	CASSETTE LID ASS'Y (DECK2)		123	RXP0053	PINCH ROLLER (R) ASS'Y	
6-1	RGU0958B-K	BUTTON (CLOSE)		123-1	RMB0260	SPRING	
6-2	RMM0122	LOD		124	RDG0206A-1	GEAR	
7	REZ0702	FPC (15P)		125	RDG0209A	GEAR	
8	HEZ0723	CABLE ASS'Y (10P)		126	REM0036-1	CAPSTAN MOTOR	
9	RGL0243-Q	LEADING LIGHT PANEL (R. PLAY)		127	REM0043	REEL MOTOR	
10	RGL0244-Q	LEADING LIGHT PANEL (F. PLAY)		128	RHD26013	SCREW	
11	RGL0245-Q	LEADING LIGHT PANEL (A)		129	RMC0169	SPRING	
12	RGL0246-Q	LEADING LIGHT PANEL (B)		130	RMQ0314A	SPACER	
13	RGU1094-K	MAIN BUTTON		131	RXG0037	GEAR ASS'Y	
14	RGU1095-K	TPS BUTTON		134	RMB0269	SPRING	
15	RMA0792	ANGLE		135	RML0270A-1	LEVER	
16	SHE185-2	P. C. B. SPACER		136	RMQ0312A	DRIVE GEAR	
20	RHD30007	SCREW		137	RMB0268	SPRING	
21	XTBS3+8JFZ1	SCREW		138	RML0271A	LEVER	
22	XTBS26+8J	SCREW		139	XTW2+6S	SCREW	
23	XTB3+10JFZ	SCREW		140	RXRD018	REEL TABLE	
24	XTW2+6S	SCREW		141	XTW2+5L	SCREW	
25	XTB3+16JFZ	SCREW		142	XTW26+12S	SCREW	
		MECHANISM PARTS		143	XTW26+6L	SCREW	
		DECK1 (PLAYBACK)		145	RFKJSCH404AK	SUB CHASSIS ASS'Y	
				146	RFKJSCH404BK	CHASSIS ASS'Y	
101	RXF0045	FLY WHEEL (F) ASS'Y		149	RYF0263-KJ	CASSETTE HOLDER ASS'Y	
101-1	RMQ0420	WASHER		149-1	RJS757ZA	SPRING	
102	RXF0046	FLY WHEEL (R) ASS'Y		150	RMQ0430	NYLON RIVET	
102-1	RMQ0421	WASHER		151	RSC0395	PLATE	
103	RML0272	SWITCH LEVER		152	XTV26+4FFZ	SCREW	
104	RXQ0265	HEAD BASE ASS'Y		153	RMB0388	SPRING	
104-1	RMB0266	SPRING		154	XWG2	WASHER	
104-2	RXM0036	ROD		155	XTN2+6J	SCREW	
105	RK0582-K	ORNAMENT PLATE					
106	RXQ0317-1	HEAD ASS'Y (P. B)					
106-1	RHD17015	AZimuth ADJUSTMENT SCREW					
106-2	RMB0352	SPRING					
106-3	RMQ0360A	CONNECTOR HOLDER					
107	RDV108ZA	BELT					
108	RDK0019A	MAIN GEAR					
109	RMB0261	SPRING					
110	RMB0262	SPRING					
111	RMB0263	SPRING					

Mechanism Parts Location • DECK 1 (PLAYBACK)

Note:
When changing mechanism parts, apply the specified grease to areas marked "XX" as shown in the drawing.

Ref. No.	Part Name	Part No.
A	FLOIL AK-152	SZZ0L 18
B	FLOIL 947P	RZZ0L 02

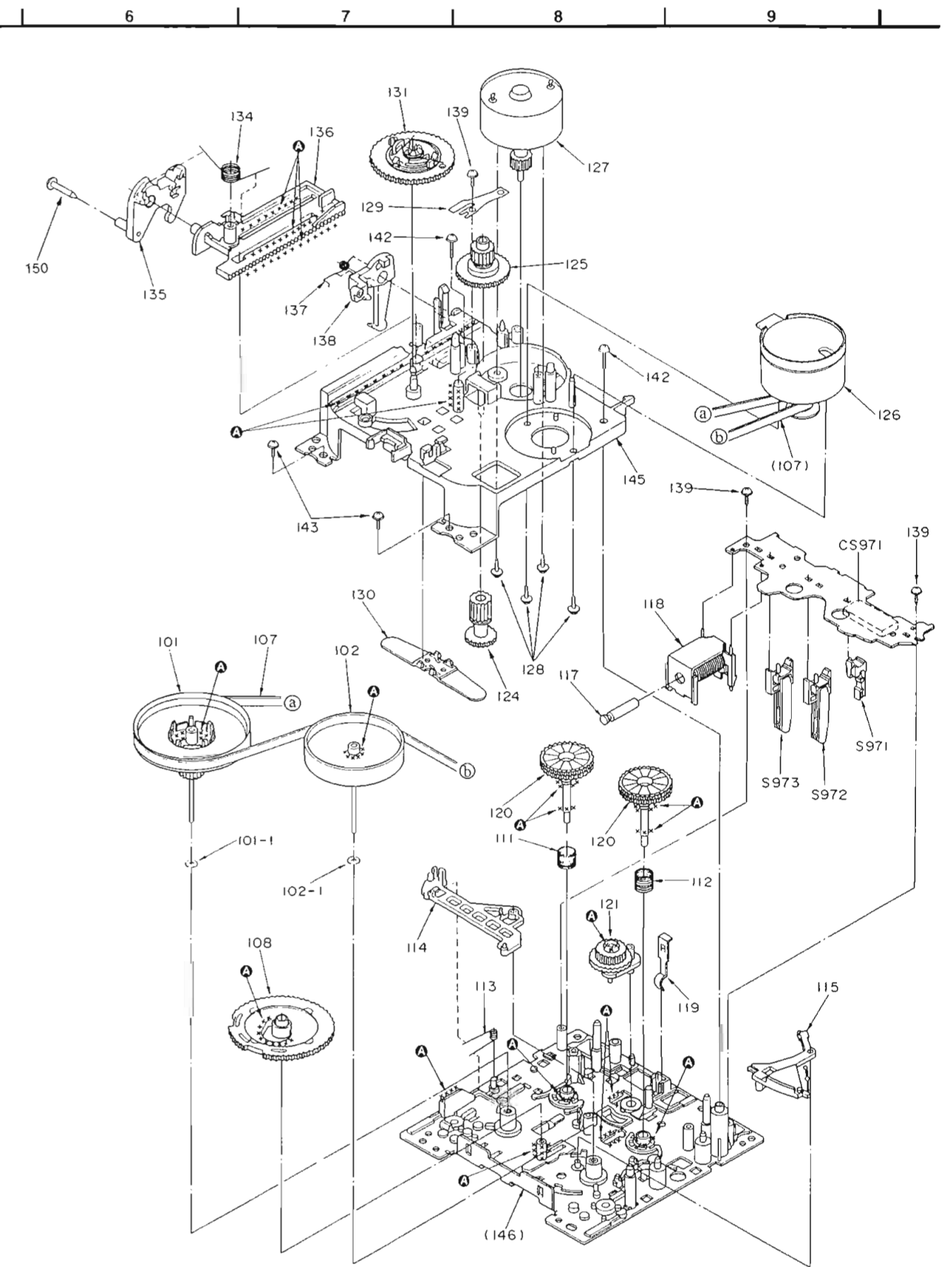
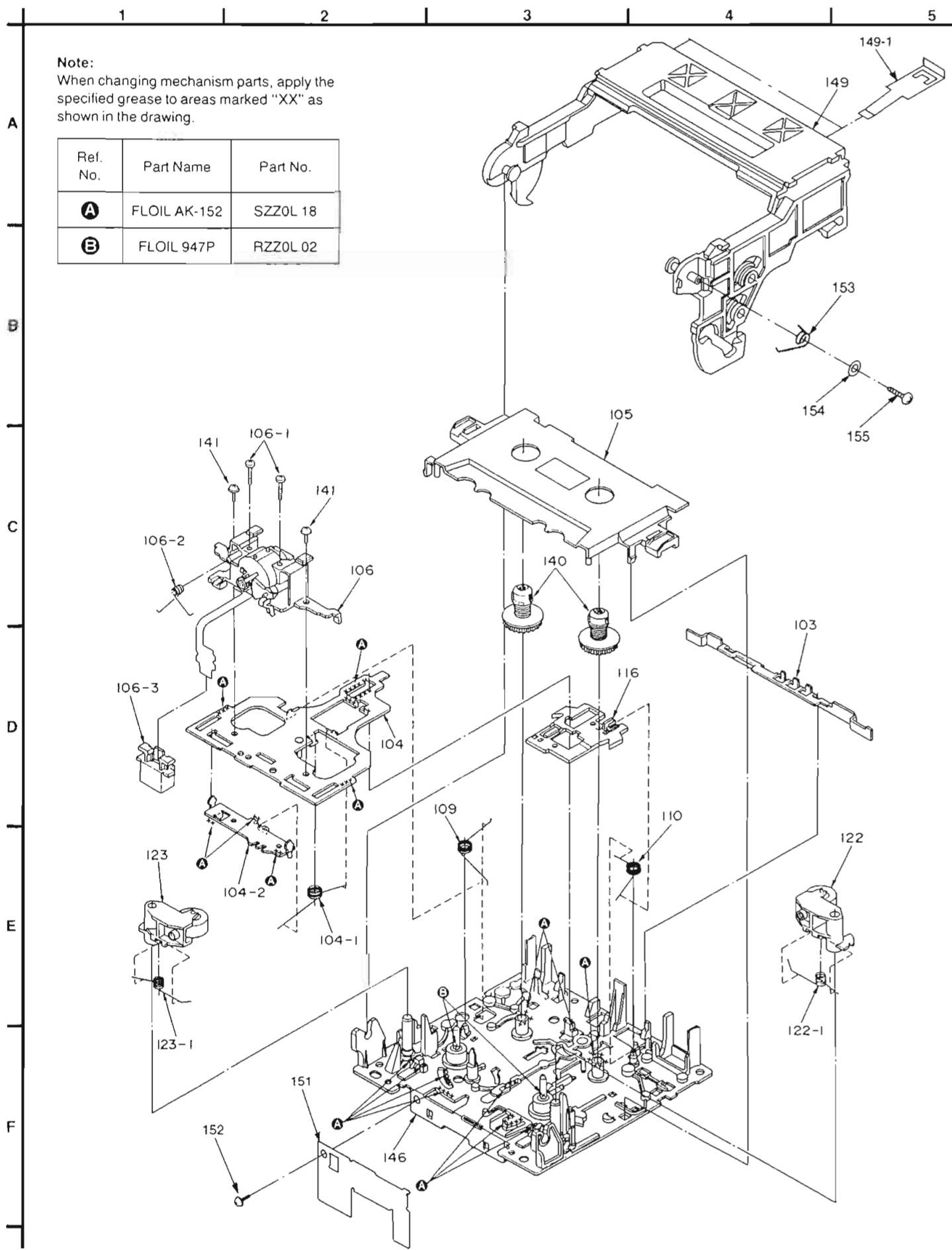

■ Mechanism Parts Location • DECK 2 (RECORD/PLAYBACK)

Note:
When changing mechanism parts, apply the specified grease to areas marked "XX" as shown in the drawing.

Ref. No.	Part Name	Part No.
A	FLOIL AK-152	SZZ0L 18
B	FLOIL 947P	RZZ0L 02

