

# Schematic Diagram

## A MAIN CIRCUIT (Printed Circuit Board: on page 15)

<b>A</b> MAIN CIRCUIT .....	19~23
<b>B</b> MECHANISM CIRCUIT (DECK 1) .....	24
<b>C</b> MECHANISM CIRCUIT (DECK 2) .....	24
<b>D</b> MOTOR CIRCUIT .....	24~26
<b>E</b> OPERATION CIRCUIT .....	26

• This schematic diagram may be modified at any time with the development of new technology.

### Notes:

- **S801** : DECK 1 cassette holder open detect switch
- **S802** : DECK 1 cassette holder close detect switch
- **S803** : DECK 2 cassette holder open detect switch
- **S804** : DECK 2 cassette holder close detect switch
- **S900** : Stop switch (■)
- **S901** : Fast forward/tape program sensor switch (TPS ▶▶▶)
- **S902** : Rewind/tape program sensor switch (◀◀◀ TPS)
- **S903** : Forward side playback switch (▶)
- **S904** : Reverse side playback switch (◀)
- **S905** : Record pause switch (● REC PAUSE)
- **S906** : One-touch tape edit switch (NORMAL)
- **S907** : One-touch tape edit switch (HIGH)
- **S908** : DECK 2 cassette holder open switch (▲ OPEN)
- **S909** : DECK 1 cassette holder open switch (▲ OPEN)
- **S910** : Dolby noise reduction switch (DOLBY B/C NR)
- **S911** : Reverse mode select switch (REVERSE MODE)
- **S912** : DECK 1/DECK 2 select switch (DECK 1/2)
- **S913** : DECK 1 cassette holder close switch (CLOSE)
- **S914** : DECK 2 cassette holder close switch (CLOSE)
- **S915** : CCRT switch (CCRT)
- **S971** : DECK 1 mode detect switch
- **S972** : DECK 1 half detect switch
- **S973** : DECK 1 CrO<sub>2</sub> tape detect switch
- **S971A** : DECK 2 mode detect switch
- **S972A** : DECK 2 half detect switch
- **S973A** : DECK 2 CrO<sub>2</sub> tape detect switch
- **S974A** : DECK 2 reverse side record prevention tab detect switch
- **S975A** : DECK 2 forward side record prevention tab detect switch
- **S976A** : DECK 2 METAL tape detect switch

• Indicated voltage values are the standard values for the unit measured by the DC electronic circuit tester (high-impedance) with the chassis taken as standard. Therefore, there may exist some errors in the voltage values, depending on the internal impedance of the DC circuit tester.

• Voltage values and waveforms are measured as indicated in the schematic diagram when test points between **TP604** and **TP605**, and between **TP606** and **TP607** are shorted.

No mark : Playback ( ) : Recording

### Important safety notice:

Components identified by ⚠ mark have special characteristics important for safety. Furthermore, special parts which have purposes of fire-retardant (resistors), high-quality sound (capacitors), low-noise (resistors), etc. are used. When replacing any of components, be sure to use only manufacturer's specified parts shown in the parts list.

### Caution!

IC and LSI are sensitive to static electricity. Secondary trouble can be prevented by taking care during repair. Cover the parts boxes made of plastics with aluminum foil. Ground the soldering iron. Put a conductive mat on the work table. Do not touch the legs of IC or LSI with the fingers directly.

### Voltage and signal line

- ▶— : Positive voltage line
- ▶--- : Negative voltage line
- ⋯▶⋯ : Playback signal Line
- ▭▶▭ : Recording signal Line

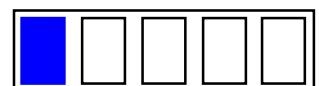
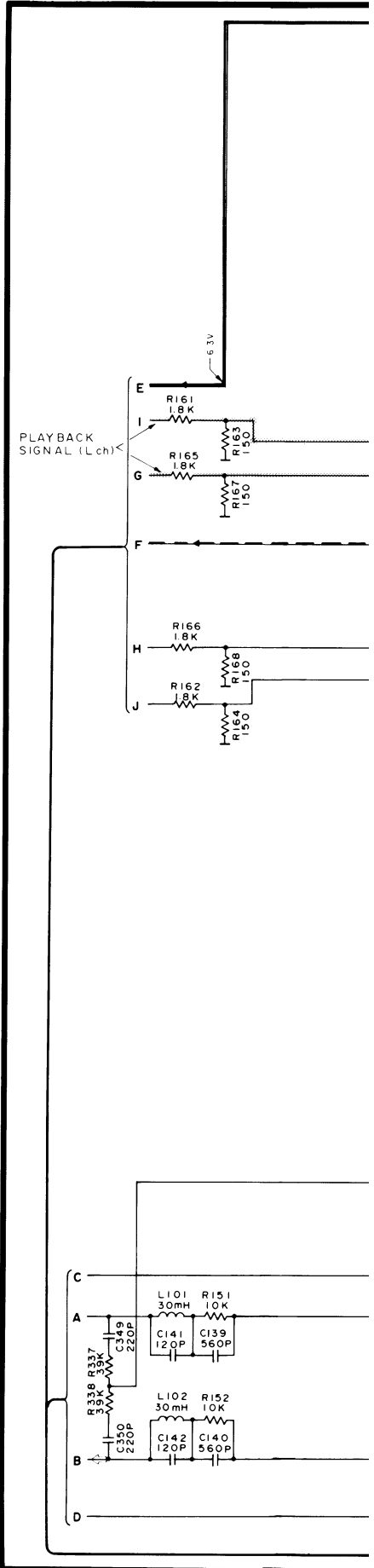

**A** MAIN CIRCUIT (REC/PLAY AMP/BIAS OSC)

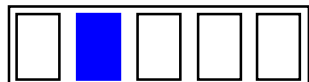
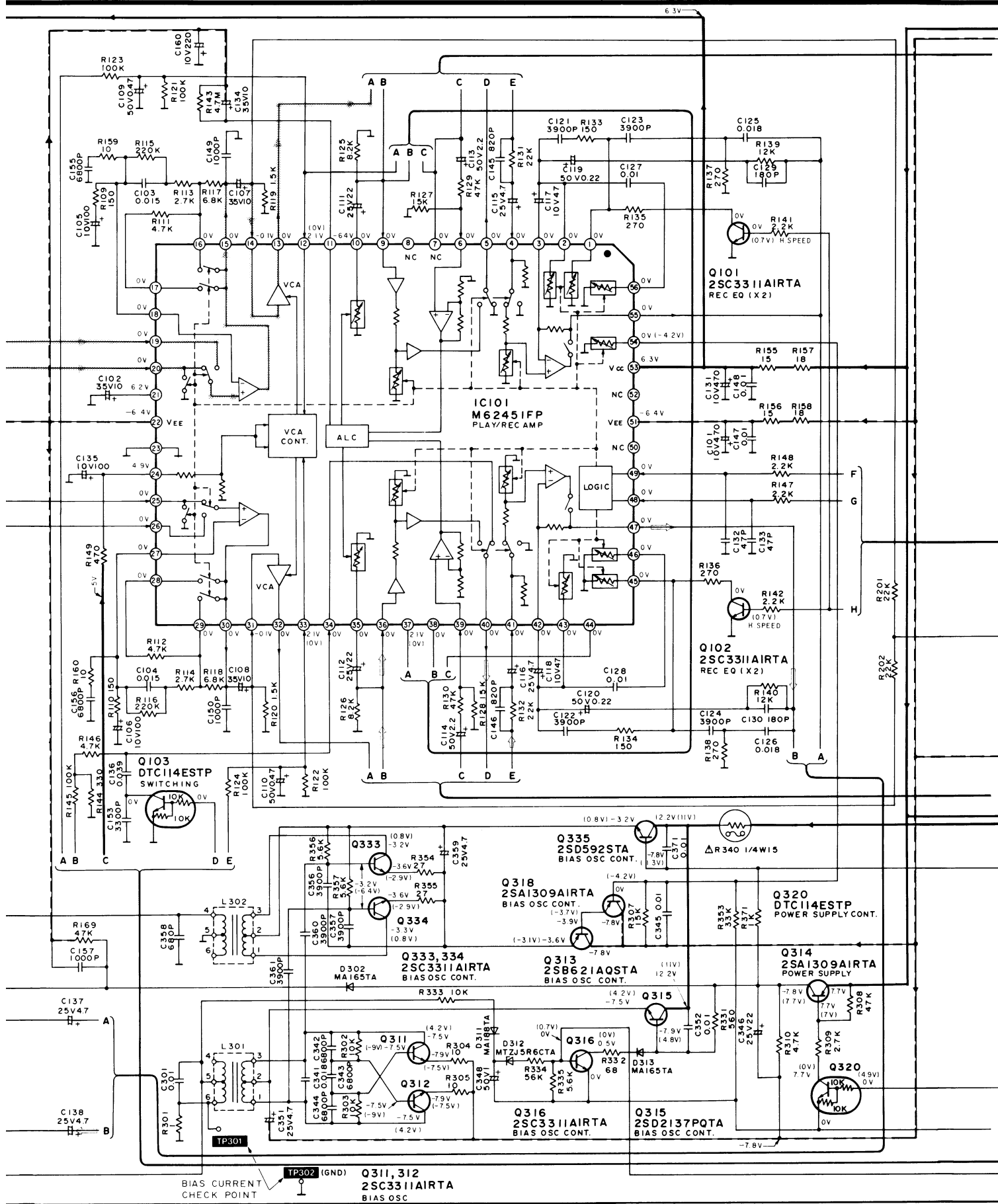

**A** MAIN CIRCUIT (DOLBY NR/MICRO COMPUTER/BUSLINE DRIVE/EEPROM/REGULATOR)

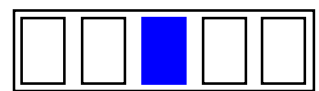
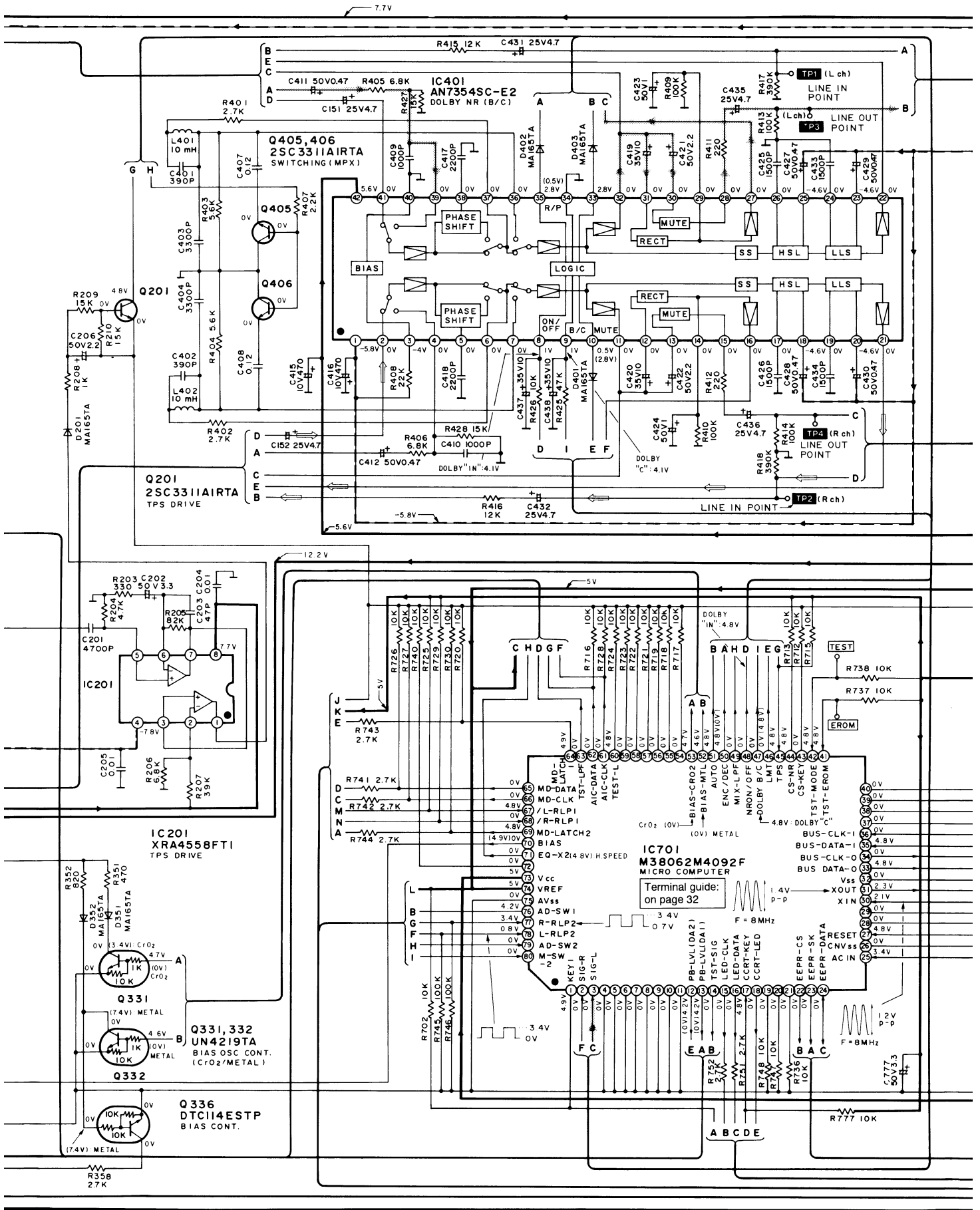

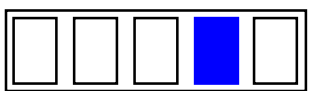
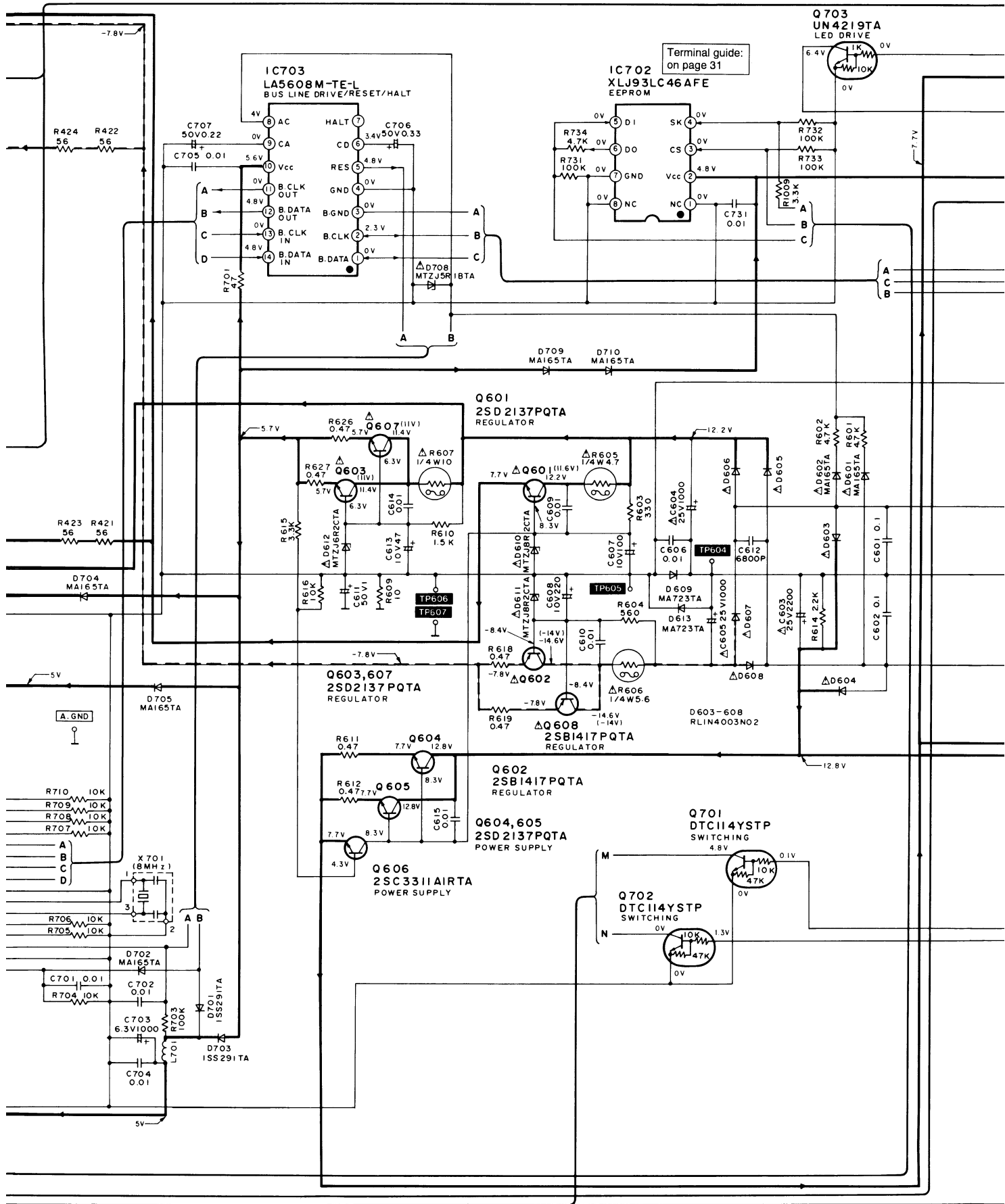

**A MAIN CIRCUIT**

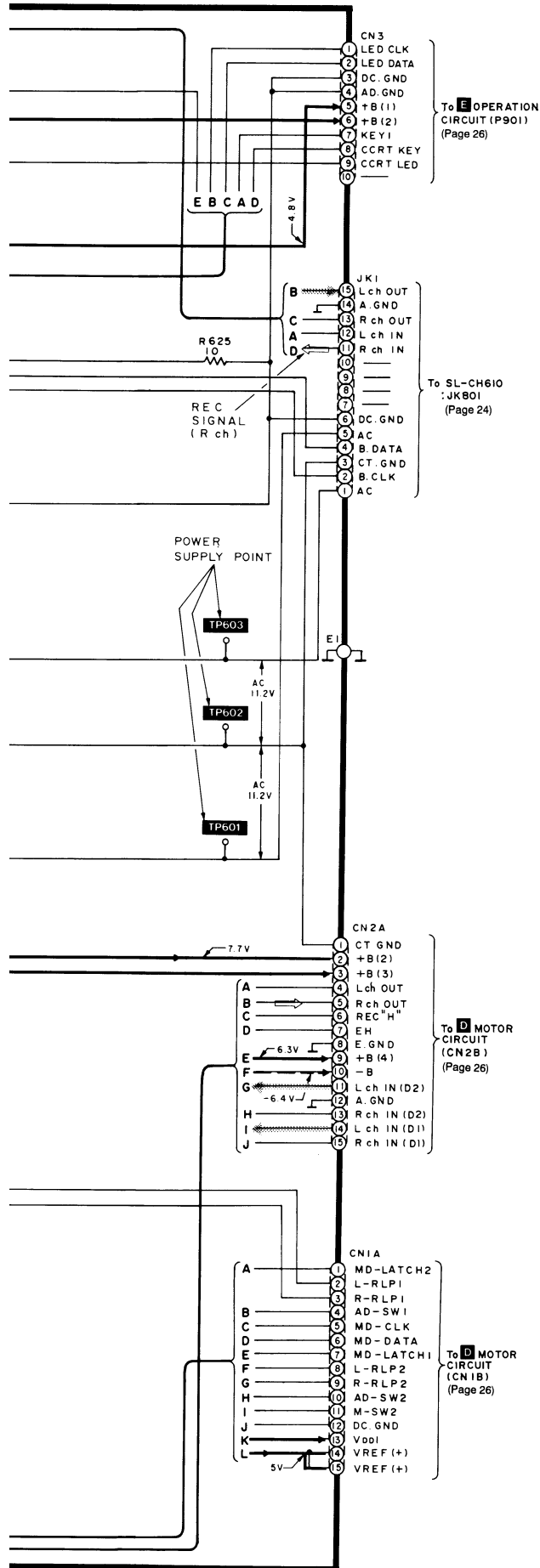

**D MOTOR CIRCUIT**  
(Printed Circuit Board: on page 17)

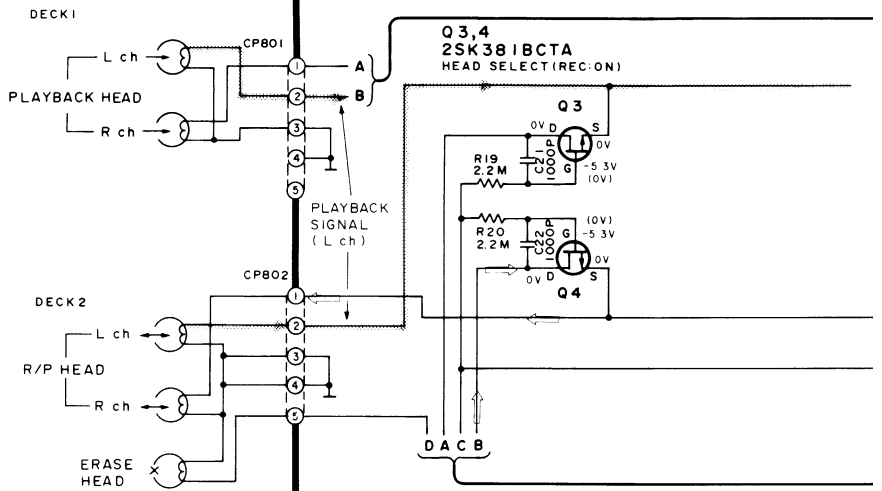

**B MECHANISM CIRCUIT (DECK 1)**  
(Printed Circuit Board: on page 18)

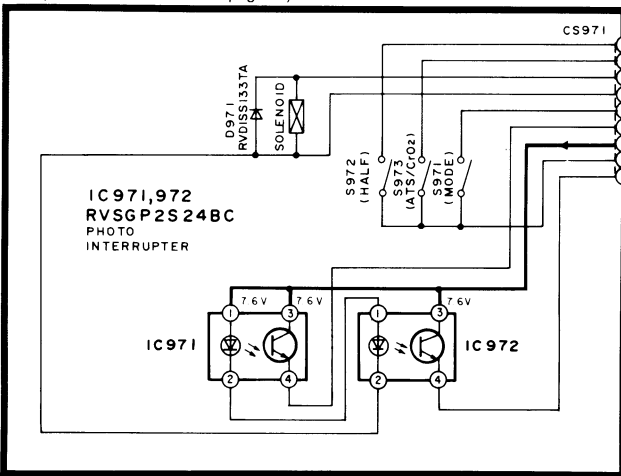

**C MECHANISM CIRCUIT (DECK 2)**  
(Printed Circuit Board: on page 18)

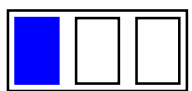
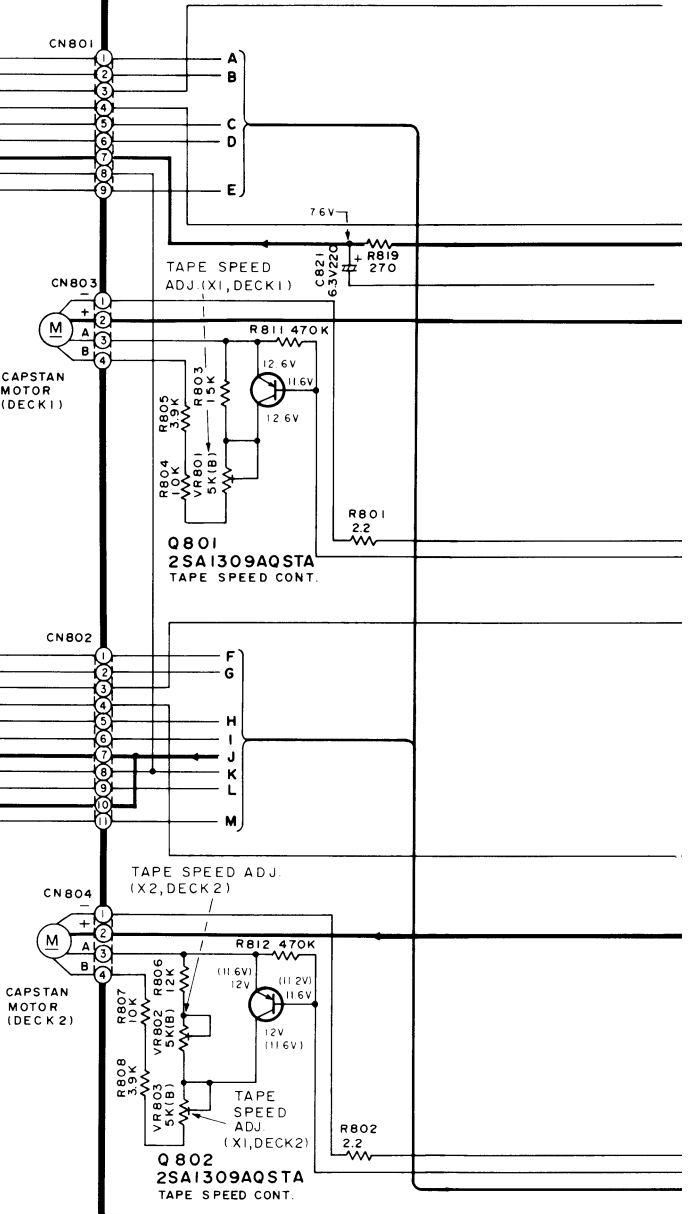
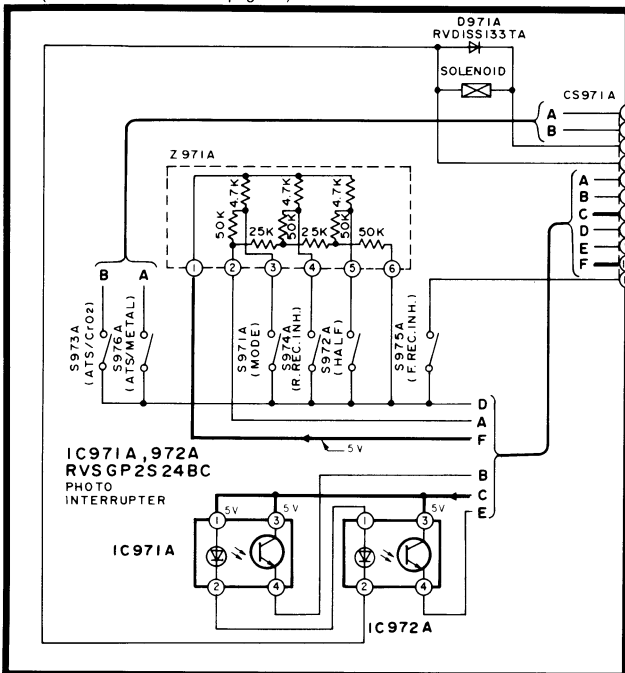

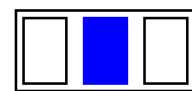
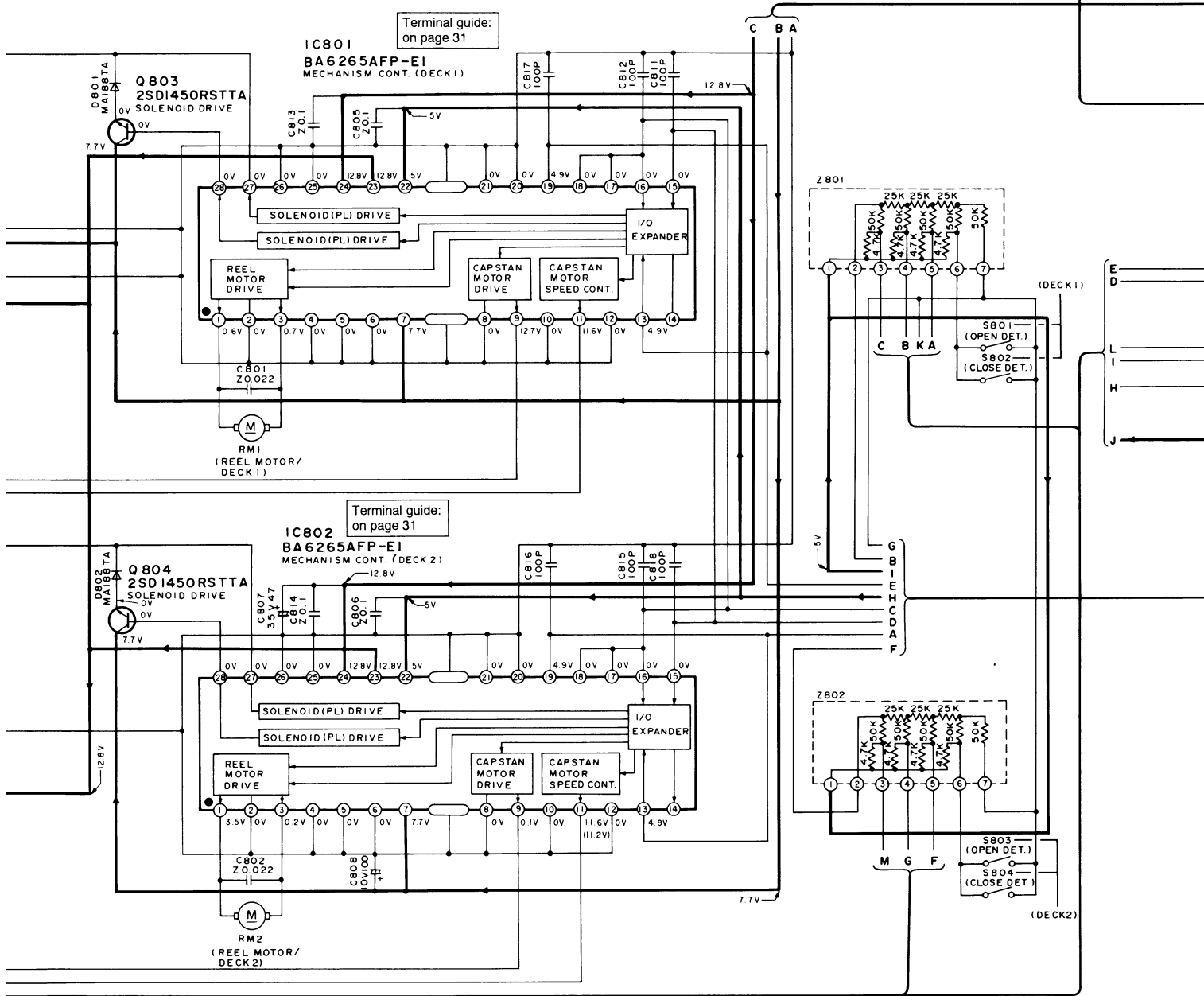
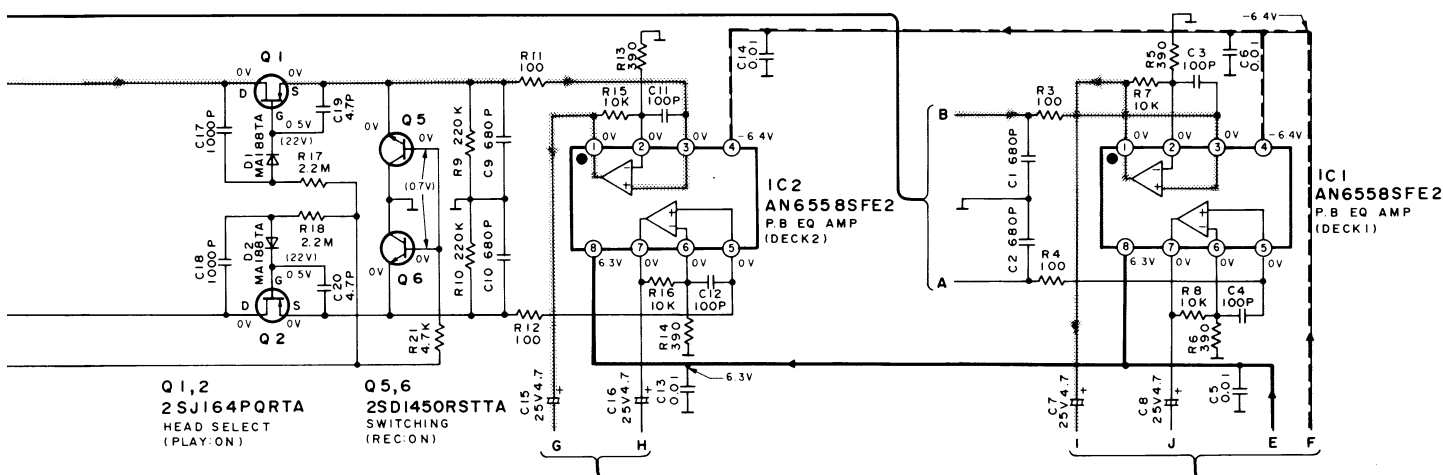



### D MOTOR CIRCUIT

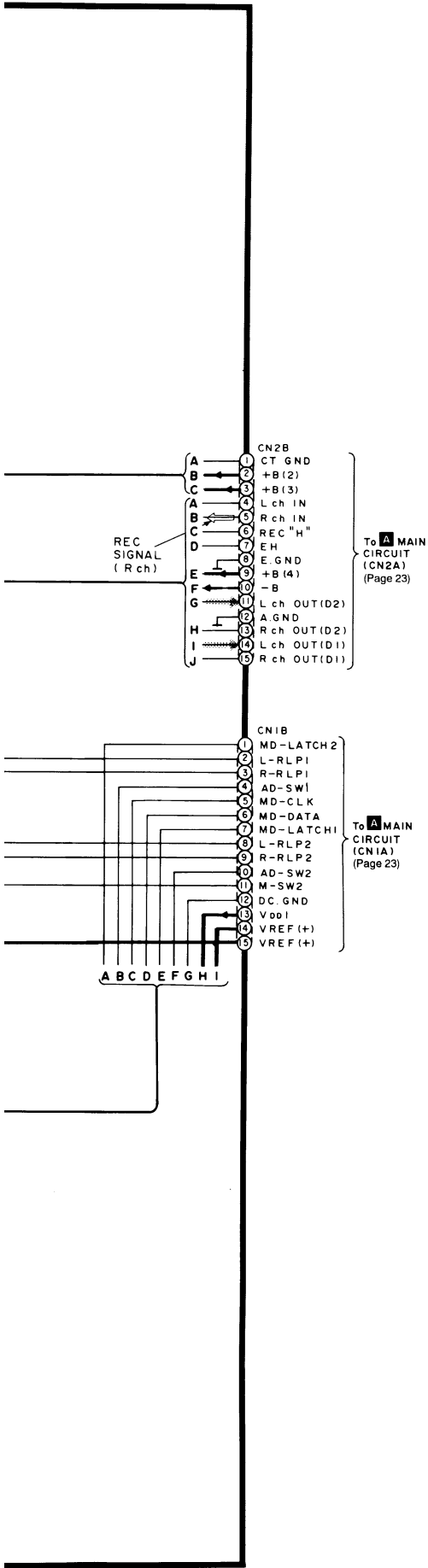

### E OPERATION CIRCUIT

(Printed Circuit Board: on page 15)

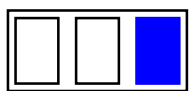
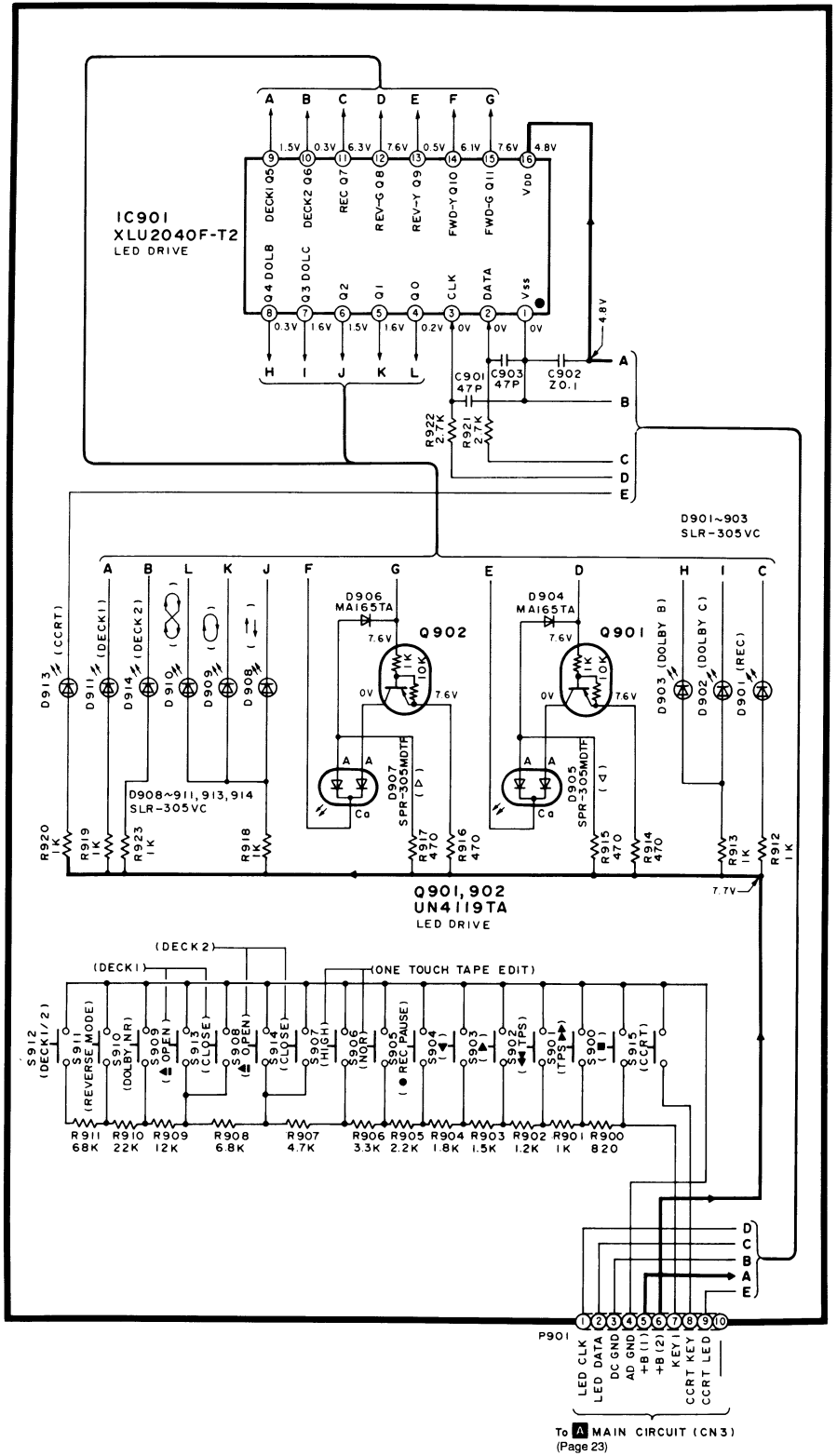



# Block Diagram

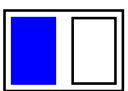
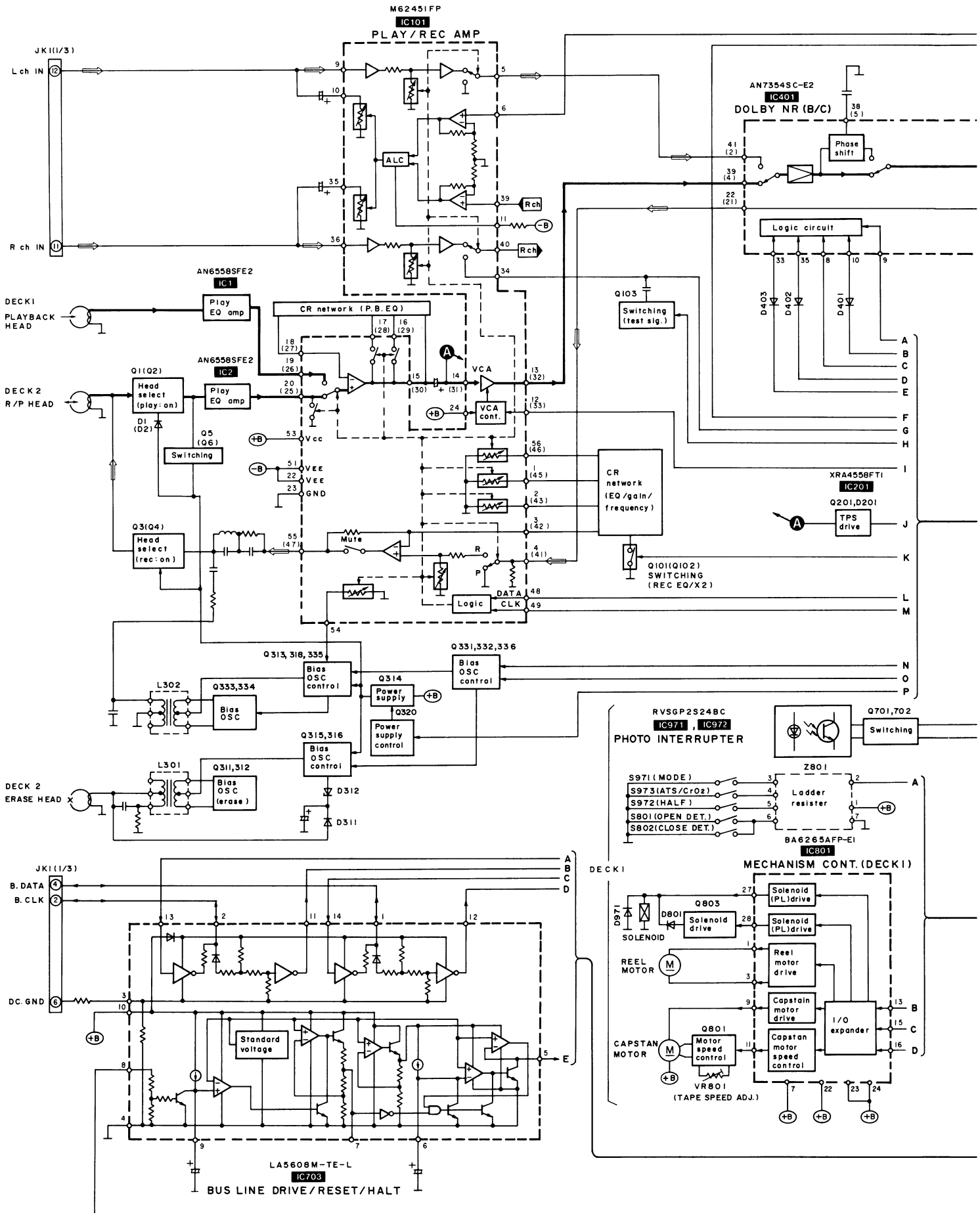

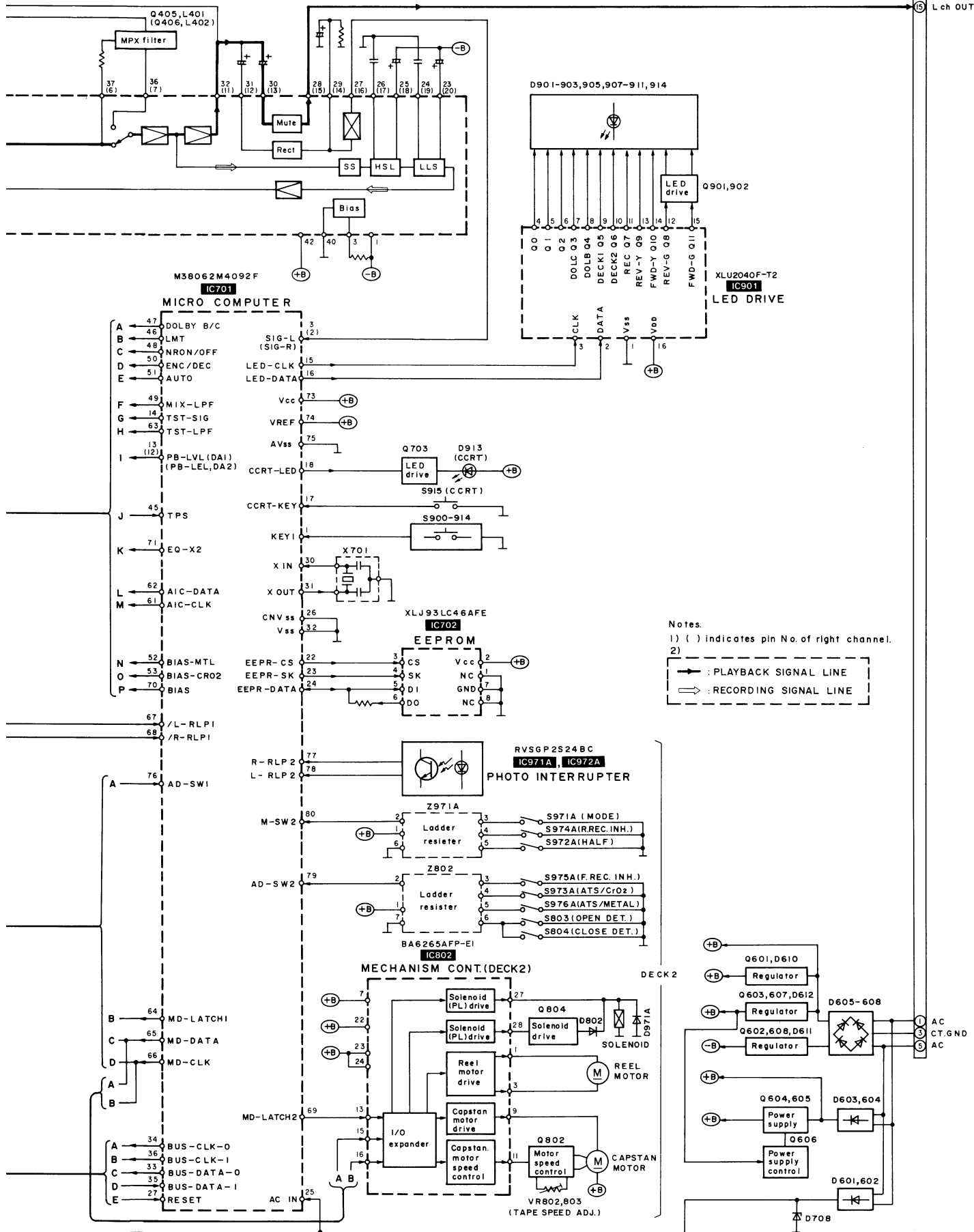

Notes.  
 1) ( ) indicates pin No. of right channel.  
 2)   
 → : PLAYBACK SIGNAL LINE  
 ⇨ : RECORDING SIGNAL LINE

