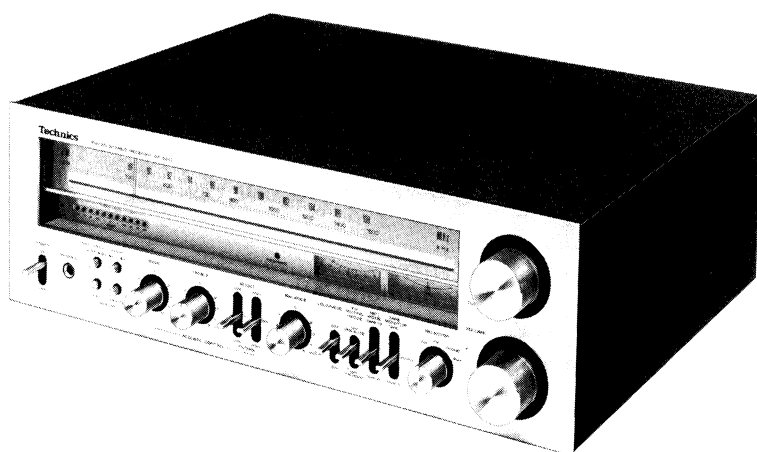

Service Manual

SA-500

FM/AM STEREO RECEIVER

SA-500

(D), (DG), (XGH), (XGF), (XE),
(XSW), (XAL), (XA), (X)

* Cabinet colour differs according to destination.

- The models SA-500 (D) and SA-500 (DG) are available in Scandinavia and European only.
- The model SA-500 (XGH) is available in Holland only.
- The model SA-500 (XGF) is available in France only.
- The model SA-500 (XSW) is available in Switzerland only.
- The model SA-500 (XE) is available in United Kingdom only.
- The model SA-500 (XAL) is available in Australia only.
- The models SA-500 (XA) and SA-500 (X) are available in Asia, Latin America, Middle East and Africa only.

TECHNICAL SPECIFICATIONS

Specifications are subject to change without notice for further improvement.

[DIN 45 500]

AMPLIFIER SECTION

1 kHz continuous power output both channels driven	2 x 70 W (4Ω), 2 x 58 W (8Ω)
40 Hz ~ 16 kHz continuous power output both channels driven	2 x 60W (4Ω), 2 x 55 W (8Ω)
20 Hz ~ 20 kHz continuous power output both channels driven	2 x 60 W (4Ω), 2 x 55 W (8Ω)
Power bandwidth both channels driven at 4Ω	10 Hz ~ 35 kHz (−3 dB)
Total harmonic distortion rated power at 1 kHz	0.04% (4Ω, 8Ω)
rated power at 40 Hz ~ 16 kHz	0.04% (4Ω, 8Ω)
rated power at 20 Hz ~ 20 kHz	0.04% (4Ω, 8Ω)
half power at 20 Hz ~ 20 kHz	0.025% (8Ω)
half power at 1 kHz	0.008% (8Ω)
−26 dB power at 1 kHz	0.04% (4Ω)
50 mW power at 1 kHz	0.2% (4Ω)
Intermodulation distortion rated power at 250 Hz: 8 kHz = 4:1, 4Ω	0.04%
rated power at 60 Hz: 7 kHz = 4:1, SMPTE, 8Ω	0.04%
Damping factor	16 (4Ω), 32 (8Ω)
Input sensitivity and impedance	
PHONO	2.5 mV/47 kΩ
AUX	150 mV/33 kΩ
PLAYBACK (TAPE 1), REC/PLAY input	180 mV/39 kΩ
PLAYBACK (TAPE 2)	150 mV/33 kΩ
PHONO maximum input voltage (1 kHz, RMS)	150 mV
S/N	
rated power at 4Ω	PHONO 70 dB (IHF, A: 78 dB) AUX 88 dB (IHF, A: 95 dB)
−26 dB power at 4Ω	PHONO 65 dB, AUX 75 dB
50 mW power at 4Ω	PHONO 60 dB, AUX 62 dB
Frequency response	PHONO RIAA standard curve 30 Hz ~ 15 kHz, ±0.2 dB AUX 20 Hz ~ 20 kHz, ±0.5 dB 10 Hz ~ 40 kHz, −1 dB
Tone controls	BASS 50 Hz, +10 dB ~ −10 dB TREBLE 10 kHz, +10 dB ~ −10 dB
Low boost at tone controls "0" position	100 Hz, +6 dB
High boost at tone controls "0" position	10 kHz, +6 dB
Low filter	100 Hz, −6 dB/oct.
High filter	7 kHz, −6 dB/oct.
Loudness control (volume at −30 dB)	50 Hz, +9 dB
Output voltage and impedance	
REC OUT (TAPE 1,2)	150 mV
REC/PLAY output	30 mV/80 kΩ

Channel balance (250 Hz ~ 6300 Hz), AUX	±1.0 dB
Channel separation at 1 kHz, AUX	55 dB
Headphones output level and impedance	500 mV/330Ω
Load impedance	MAIN or REMOTE 4 ~ 16Ω MAIN + REMOTE 8 ~ 16Ω

FM TUNER SECTION

Frequency range	88 ~ 108 MHz
Antenna terminals	300Ω (balanced), 75Ω (unbalanced)
Sensitivity (±40 kHz deviation)	
S/N 30 dB	1.9μV (300Ω), 1.3μV (75Ω)
S/N 26 dB	1.7μV (300Ω), 1.2μV (75Ω)
S/N 20 dB	1.5μV (300Ω), 0.9μV (75Ω)
IHF usable sensitivity	1.9μV (IHF '58)
IHF S/N 46 dB stereo quieting sensitivity	22μV (75Ω)
Total harmonic distortion	MONO 0.15% STEREO 0.3%
S/N (±40 kHz deviation)	MONO 60 dB (IHF: 75 dB) STEREO 56 dB (IHF: 70 dB)
Frequency response	20 Hz ~ 15 kHz, +1 dB, −2 dB 20 Hz ~ 14 kHz, ±1.5 dB
Alternate channel selectivity	70 dB
Capture ratio	1.2 dB
Image rejection at 98 MHz	70 dB
IF rejection at 98 MHz	90 dB
Spurious response rejection at 98 MHz	80 dB
AM suppression	55 dB
Stereo separation	1 kHz 45 dB, 10 kHz 35 dB
Leak carrier	19 kHz −33 dB (−40 dB, IHF) 38 kHz −48 dB (−50 dB, IHF)
Limiting point	1.2μV
Bandwidth	IF amplifier 180 kHz FM demodulator 1000 kHz
Channel balance (250 Hz ~ 6300 Hz)	±1.5 dB

AM TUNER SECTION

Frequency range	525 ~ 1605 kHz
Sensitivity (S/N 20 dB)	30μV, 300μV/m
Selectivity	30 dB
Image rejection at 1000 kHz	45 dB
IF rejection at 1000 kHz	40 dB

GENERAL

Power consumption	550 W
Power supply (50 Hz/60 Hz)	110V/120V/220V/240V
Dimensions (W x H x D)	450 x 149 x 329 mm (17 ³ / ₃₂ " x 5 ⁷ / ₁₆ " x 12 ¹⁵ / ₁₆ ")
Weight	11.4 kg (25.1 lb.)

Technics

Matsushita Electric Trading Co., Ltd.
P.O. Box 288, Central Osaka Japan

LOCATION OF CONTROLS (Front panel view)

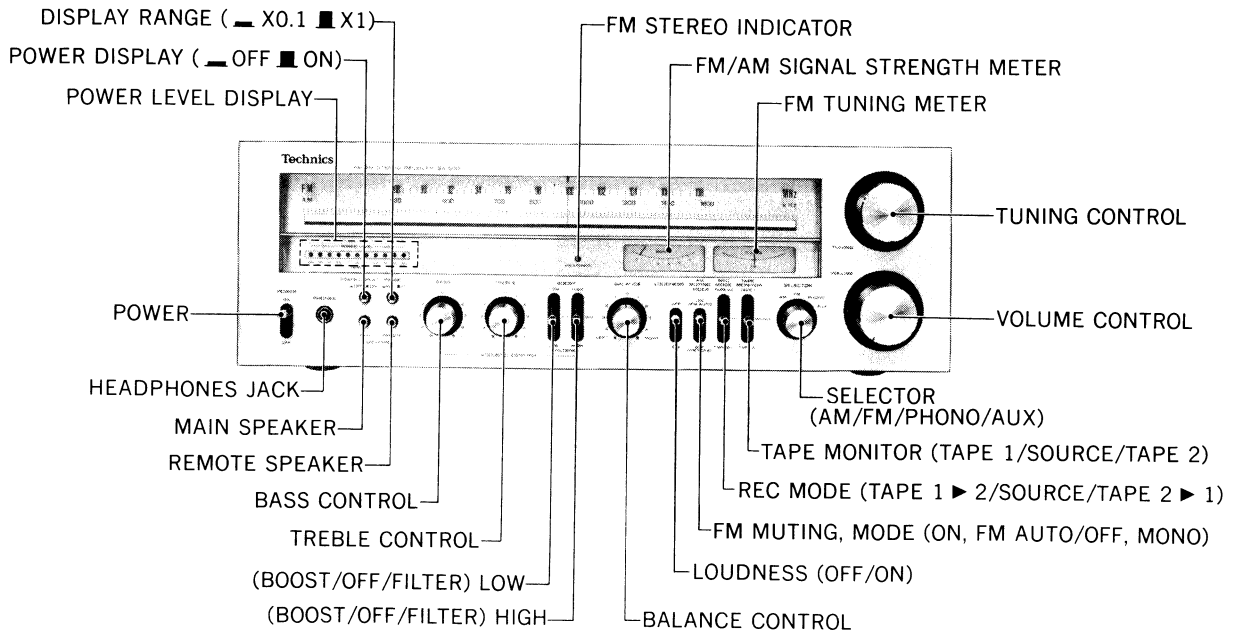

TECHNISCHE DATEN

Spezifikationen können infolge von Verbesserungen ohne Ankündigung geändert werden.

[DIN 45 500]

VERSTÄRKERTEIL

Dauertonleistung bei 1 kHz
beide Kanäle angesteuert 2 x 70 W (4Ω), 2 x 58 W (8Ω)

Dauertonleistung bei 40 Hz ~ 16 kHz
beide Kanäle angesteuert 2 x 60 W (4Ω), 2 x 55 W (8Ω)

Dauertonleistung bei 20 Hz ~ 20 kHz
beide Kanäle angesteuert 2 x 60 W (4Ω), 2 x 55 W (8Ω)

Leistungsbandbreite
beide Kanäle angesteuert bei 4Ω 10 Hz ~ 35 kHz (-3 dB)

Klirrfaktor
Nennausgangsleistung bei 1 kHz 0,04% (4Ω, 8Ω)
Nennausgangsleistung bei 40 Hz ~ 16 kHz 0,04% (4Ω, 8Ω)
Nennausgangsleistung bei 20 Hz ~ 20 kHz 0,04% (4Ω, 8Ω)
Halber Ausgangsleistung bei 20 Hz ~ 20 kHz 0,025% (8Ω)
Halber Ausgangsleistung bei 1 kHz 0,008% (8Ω)
-26 dB Ausgangsleistung bei 1 kHz 0,04% (4Ω)
50 mW Ausgangsleistung bei 1 kHz 0,2% (4Ω)

Intermodulationsverzerrung
Nennausgangsleistung bei 250 Hz: 8 kHz = 4:1, 4Ω 0,04%
Nennausgangsleistung bei 60 Hz: 7 kHz = 4:1, 8Ω 0,04%

Dämpfungsfaktor 16 (4Ω), 32 (8Ω)

Eingangsempfindlichkeit und Impedanz
PHONO 2,5 mV/47 kΩ
AUX 150 mV/33 kΩ
PLAYBACK (TAPE 1), REC/PLAY Eingang 180 mV/39 kΩ
PLAYBACK (TAPE 2) 150 mV/33 kΩ

PHONO Maximale Eingangsspannungen (1 kHz RMS) 150 mV

Rauschabstand
Nennausgangsleistung bei 4Ω PHONO 70 dB (IHF, A: 78 dB)
AUX 88 dB (IHF, A: 95 dB)

-26 dB Ausgangsleistung bei 4Ω PHONO 65 dB
AUX 75 dB

50 mW Ausgangsleistung bei 4Ω PHONO 60 dB, AUX 62 dB

Frequenzgang PHONO nach RIAA 30 Hz ~ 15 kHz, ±0,2 dB
AUX 20 Hz ~ 20 kHz, ±0,5 dB
10 Hz ~ 40 kHz, -1 dB

Klangregler BÄSSE 50 Hz, +10 dB ~ -10 dB
HÖHEN 10 kHz, +10 dB ~ -10 dB

Akustikregler (Tonregler in "0"-Position)
LOW BOOST 100 Hz, +6 dB, HIGH BOOST 10 kHz, +6 dB

Tiefenfilter 100 Hz, -6 dB/oct.
Höhenfilter 7 kHz, -6 dB/oct.

Gehörchtige Lautstärke (Lautstärke bei -30 dB) 50 Hz, +9 dB

Ausgangsspannungen und Impedanz
REC OUT (TAPE 1, 2) 150 mV
REC/PLAY Aufnahme 30 mV/80 kΩ

Kanalabweichung (250 Hz ~ 6300 Hz), AUX ±1,0 dB
Kanalrennung bei 1 kHz, AUX 55 dB
Kopfhörerpegel und Ausgangsimpedanz 500 mV/330Ω
Ausgangsimpedanz MAIN oder REMOTE 4 ~ 16Ω
MAIN und REMOTE 8 ~ 16Ω

UKW-TUNERTEIL

Frequenzgang 88 ~ 108 MHz
Antennenanschluss 300Ω (symmetrisch), 75Ω (unsymmetrisch)
Empfindlichkeit (±40 kHz Hub)
30 dB Rauschabstand 1,9μV (300Ω), 1,3μV (75Ω)
26 dB Rauschabstand 1,7μV (300Ω), 1,2μV (75Ω)
20 dB Rauschabstand 1,5μV (300Ω), 0,9μV (75Ω)
Empfindlichkeit nach IHF 1,9μV (IHF '58)
46 dB Rauschabstand utilisable Empfindlichkeit nach IHF 22μV (75Ω), STEREO
Klirrfaktor MONO 0,15%, STEREO 0,3%

Rauschabstand (±40 kHz Hub)
MONO 60 dB (IHF: 75 dB), STEREO 56 dB (IHF: 70 dB)
Frequenzgang 20 Hz ~ 15 kHz, +1 dB, -2 dB
20 Hz ~ 14 kHz, ±1,5 dB

Selektivität 70 dB
Gleichwellen-Selektion 1,2 dB
Spiegelfrequenzunterdrückung bei 98 MHz 70 dB
ZF-Festigkeit bei 98 MHz 90 dB
Unselektivität-Dämpfung bei 98 MHz 80 dB
AM-Unterdrückung 55 dB
Kanalrennung 1 kHz 45 dB, 10 kHz 35 dB
Hilfsträgerdämpfung (Pilotton) 19 kHz -33 dB (-40 dB, IHF)
38 kHz -48 dB (-50 dB, IHF)
Begrenzungseinsatz ZF-Verstärker 1,2μV
Bandbreite Ratiodetektor 180 kHz
1000 kHz
Kanalabweichung (250 Hz ~ 6300 Hz) ±1,5 dB

AM-TUNERTEIL

Frequenzgang 525 ~ 1605 kHz
Empfindlichkeit (20 dB Rauschabstand) 30μV, 300μV/m
Selektivität 30 dB
Spiegelfrequenz-Selektion bei 1000 kHz 45 dB
ZF-Festigkeit bei 1000 kHz 40 dB

ALLGEMEINE DATEN

Leistungsaufnahme 550 W
Netzspannung (50 Hz/60 Hz) 110V/120V/220V/240V
Abmessungen (B x H x T) 450 x 149 x 329 mm
Gewicht 11,4 kg

■ LOCATION OF CONTROLS (Rear panel view)

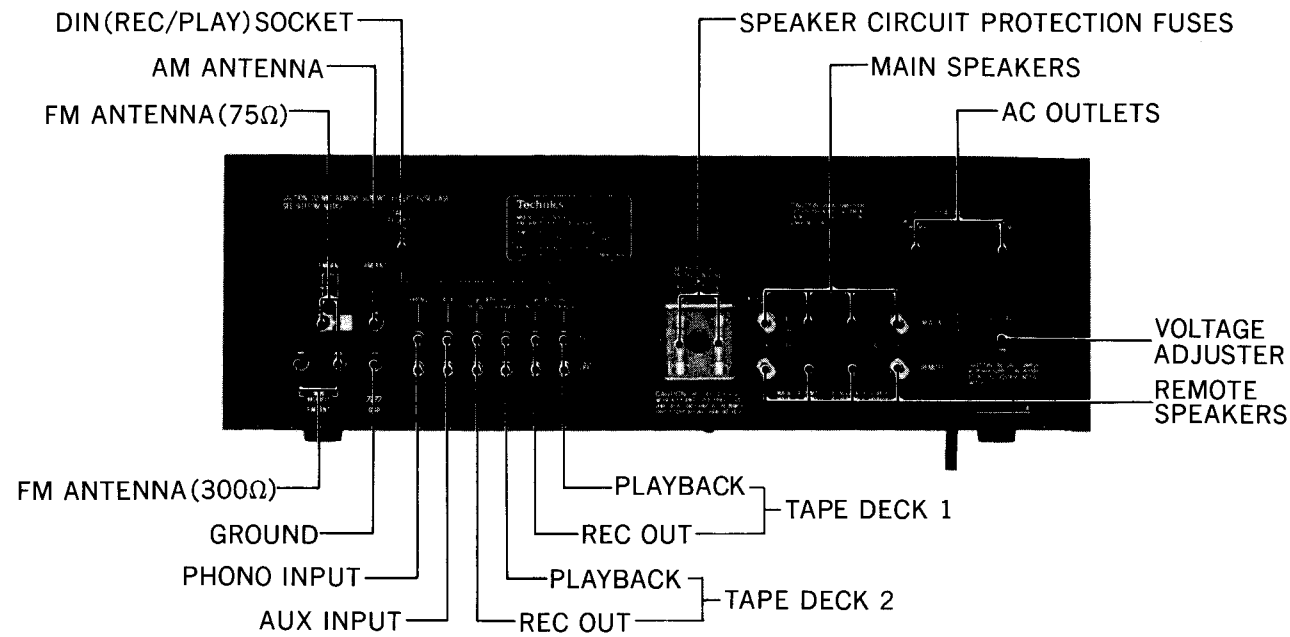

* The products for other destinations except (XA) and (X) are not equipped with AC outlets.

CARACTERISTIQUES TECHIQUES Sujet à changement sans préavis.

[DIN 45 500]

PARTIE AMPLIFICATEUR

1 kHz, puissance continue les 2 canaux modulés 2 x 70 W (4Ω), 2 x 58W (8Ω)

40 Hz ~ 16 kHz, puissance continue les 2 canaux modulés 2 x 60 W (4Ω), 2 x 55W (8Ω)

20 Hz ~ 20 kHz, puissance continue les 2 canaux modulés 2 x 60 W (4Ω) 2 x 55 W (8Ω)

Largeur de bande de puissance les 2 canaux modulés à 4 Ω 10 Hz ~ 35 kHz (-3dB)

Distorsion harmonique totale pour la puissance nominale, 1 kHz 0,04% (4Ω, 8Ω)

pour la puissance nominale, 40 Hz ~ 16 kHz 0,04% (4Ω, 8Ω)

pour la puissance nominale, 20 Hz ~ 20 kHz 0,04% (4Ω, 8Ω)

pour la demi-puissance nominale, 20 Hz ~ 20 kHz 0,025% (8Ω)

pour la demi-puissance nominale, 1 kHz 0,008% (8Ω)

pour une puissance mesurée de -26 dB, 1 kHz 0,04% (4Ω)

pour une puissance mesurée de 50 mW, 1 kHz 0,2% (4Ω)

Distorsion d'intermodulation pour la puissance nominale, 250 Hz: 8 kHz = 4:1, 4Ω 0,04%

pour la puissance nominale, 60 Hz: 7 kHz = 4:1, 8Ω 0,04%

Facteur d'amortissement 16 (4Ω), 32 (8Ω)

Sensibilité et impédance d'entrée PHONO 2,5 mV/47 kΩ

AUX 150 mV/33 kΩ

PLAYBACK (TAPE 1), REC/PLAY entrée 180 mV/39 kΩ

PLAYBACK (TAPE 2) 150 mV/33 kΩ

Tension maximum d'entrée PHONO (1 kHz, eff.) 150 mV

Rapport signal/bruit pour la puissance nominale, 4Ω PHONO 70 dB (IHF, A: 78 dB)

AUX 88 dB (IHF, A: 95 dB)

pour une puissance mesurée de -26 dB, 4Ω PHONO 65 dB AUX 75 dB

pour une puissance mesurée de 50mW, 4Ω PHONO 60 dB AUX 62 dB

Réponse de fréquence PHONO Courbe standard RIAA 30 Hz ~ 15 kHz, ±0,2 dB

AUX 20 Hz ~ 20 kHz, ±0,5 dB

Réglage de la tonalité BASS (graves) 10 Hz ~ 40 kHz, -1 dB

TREBLE (aigus) 50 Hz, +10dB ~ -10 dB

10kHz, +10dB ~ -10 dB

Commandes acoustiques (commandes de tonalité sur "0") LOW BOOST 100 Hz, +6 dB, HIGH BOOST 10 kHz, +6 dB

Filtre de grave 100 Hz, -6 dB/oct.

Filtre d'aigu 7 kHz, -6 dB/oct.

Correction physiologique (volume à -30 dB) 50 Hz, +9 dB

Tension de sortie REC OUT (TAPE 1, 2) 150 mV

REC/PLAY (sortie) 30 mV/80 kΩ

Equilibrage de canaux (250 Hz ~ 6300 Hz), AUX ±1,0 dB

Ecart canaux à 1 kHz, AUX 55 dB

Niveau des écouteurs et impédance de sortie 500 mV/330Ω

Impédance de charge PRINCIPALE ou ELOIGNEE 4 ~ 16Ω

PRINCIPALE + ELOIGNEE 8 ~ 16Ω

PARTIE TUNER FM

Gamme reçue 88 ~ 108 MHz

Impédance d'antenne 300Ω (symétrique) 75Ω (asymétrique)

Sensibilité (±40 kHz déviation) Signal/bruit 30 dB 1,9μV (300Ω), 1,3μV (75Ω)

Signal/bruit 26 dB 1,7μV (300Ω), 1,2μV (75Ω)

Signal/bruit 20 dB 1,5μV (300Ω), 0,9μV (75Ω)

IHF Sensibilité 1,9μV (IHF '58)

IHF Sensibilité pour S/B 46 dB 22μV (75Ω), STÉRÉO

Distorsion harmonique totale MONO 0,15% STEREO 0,3%

Signal/bruit (±40 kHz déviation) MONO 60 dB (IHF: 75 dB)

STEREO 56 dB (IHF: 70 dB)

Réponse de fréquence 20 Hz ~ 15 kHz, +1 dB, -2 dB

20 Hz ~ 14 kHz, ±1,5 dB

Sélectivité en canaux alternés Taux de capture 70 dB

Réjection de fréquence image à 98 MHz 1,2 dB

Réjection FI à 98 MHz 70 dB

Réjection de réception non sélective à 98 MHz 90 dB

Suppression AM 80 dB

Séparation stéréophonique 1 kHz 45 dB, 10 kHz 35 dB

Courant porteur de dispersion 19 kHz -33 dB (-40 dB, IHF)

38 kHz -48 dB (-50 dB, IHF)

Point limite 1,2μV

Largeur de bande Amplificateur FI 180 kHz

Démodulateur FM 1000 kHz

Equilibrage de canaux (250 Hz ~ 6300 Hz) ±1,5 dB

PARTIE TUNER AM

Gamme reçue 525 ~ 1605 kHz

Sensibilité (Rapport S/B 20 dB) 30μV, 300μV/m

Sélectivité 30 dB

Réjection de fréquence image à 1000 kHz 45 dB

Réjection FI à 1000 kHz 40 dB

GENERALITES

Consommation 550 W

Alimentation (50 Hz/60 Hz) 110V/120V/220V/240V

Dimensions (L x H x P) 450 x 149 x 329 mm

Poids 11,4 kg

■ CHASSIS VIEW

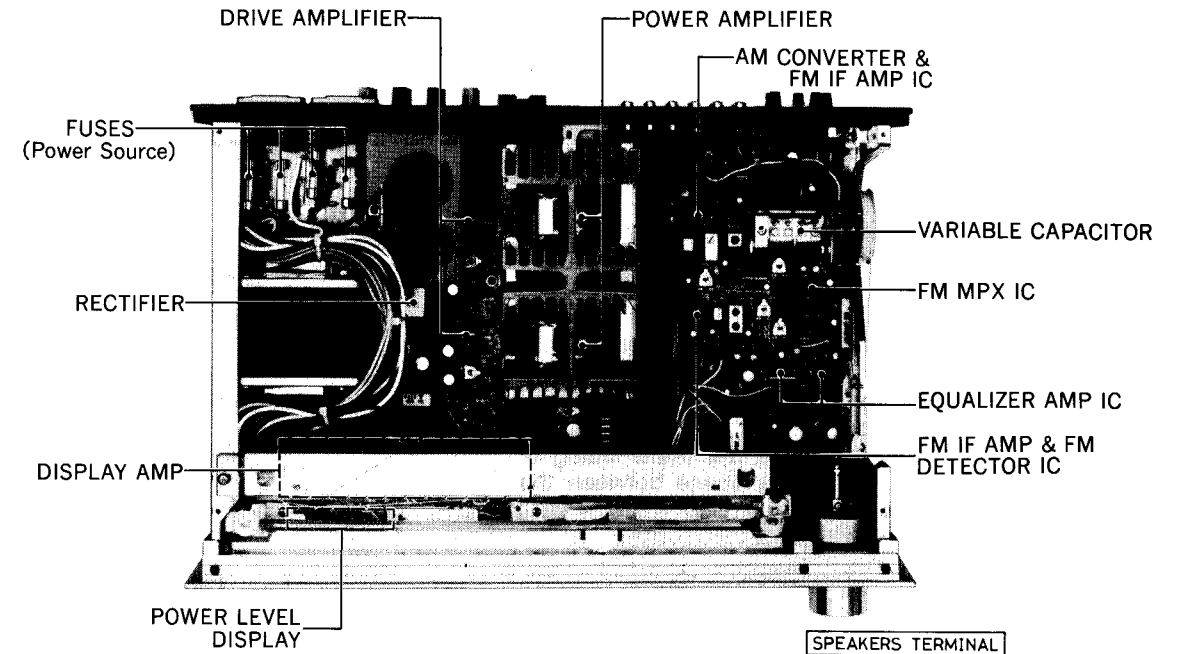

■ ALIGNMENT INSTRUCTIONS

• Main amplifier (ICQ) alignment.

- The "ICQ" adjustment should be started about 5 minutes. After setting the power switch to the ON position.
- Left channel
 - * Connect DC voltmeter between TP601 and TP602.
 - * Adjust VR601 to 8 mV on DC voltmeter indication.
- Right channel
 - * Connect DC voltmeter between TP601 and TP602.
 - * Adjust VR602 to 8 mV on DC voltmeter indication.

■ ANWEISUNGEN FÜR ABGLEICHUNG

• Abgleichung des Hauptverstärkers (ICQ)

- Die "ICQ" Regulierung soll in ca. 5 Minuten begonnen werden, nachdem der Hauptschalter auf ON eingestellt worden ist.
- DC-Voltmeter zwischen TP601 und TP602 des linken Kanals (LEFT) anschließen.
- VR601 auf 8 mV der DC-Voltmeteranzeige regulieren.
- DC-Voltmeter zwischen TP601 und TP602 des rechten Kanals (RIGHT) anschließen.
- VR602 auf 8 mV der DC-Voltmeteranzeige regulieren.

■ INSTRUCTIONS D'ALIGNMENT

• Alignement de l'amplificateur principal (ICQ)

- L'alignement "ICQ" doit être commencé environ 5 mn après avoir placé le commutateur d'alimentation sur la position ON.
- Brancher le volt-mètre de courant continu entre TP601 et la TP602 du canal gauche (LEFT).
- Ajuster VR601 à 8 mV sur l'indication du volt-mètre de courant continu.
- Brancher le volt-mètre de courant continu entre TP601 et la TPP602 du canal droit (RIGHT).
- Ajuster VR602 à 8 mV sur l'indication du volt-mètre de courant continu.

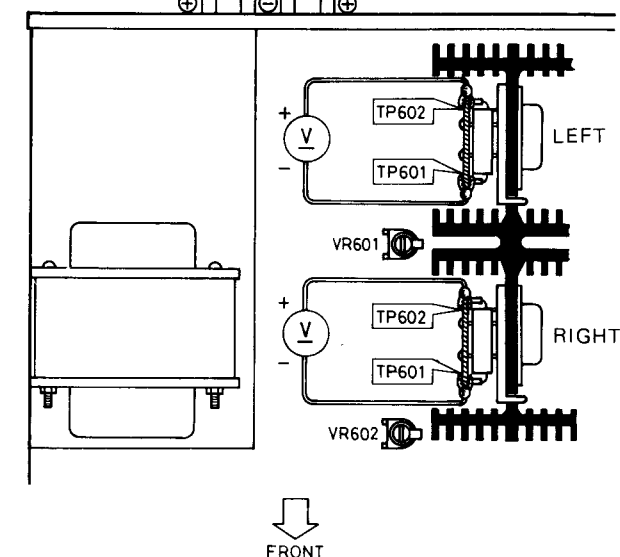

NOTE The unit is provided with the speaker circuit protection fuses at the right and left channels respectively. The fuse is to prevent the power transistor from destruction, should the speaker terminals be short-circuited. Accordingly, if the unit fails to function upon completion of the speaker connections, check the speaker circuit protection fuses first of all for possible blowing.

TO REMOVE CABINET

- Remove the two cabinet mounting screws (nos ①, ② screws in fig. 1).
- Remove the four cabinet mounting screws (nos ①~④ screws in fig. 2).
- Sliding it toward (A) direction and lifting it upward (B) direction as shown in fig. 2.
- When the cabinet is installed, insert the metal fitting of cabinet (as shown in fig. 3) into the space between the front panel and light reflector.

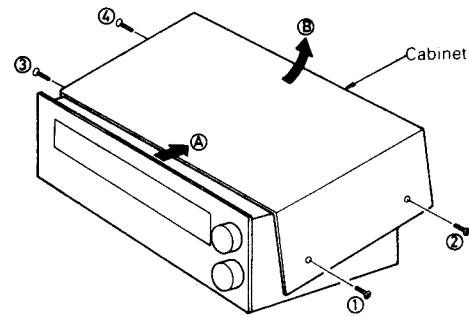

Fig. 2

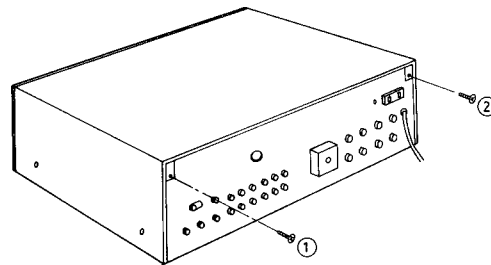

Fig. 1

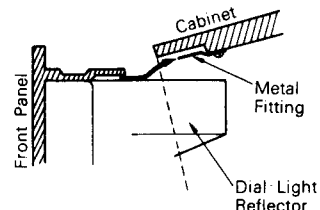

Fig. 3

ALIGNMENT POINTS

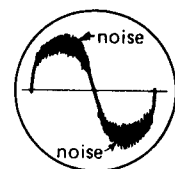
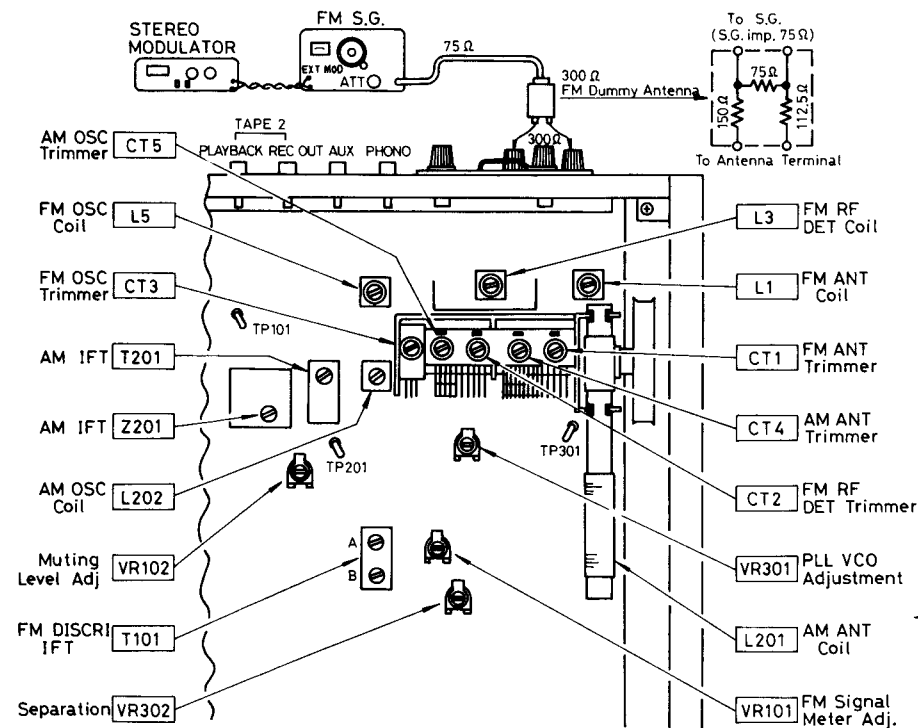
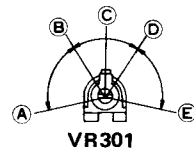

Fig. 4 (Abb. 4)



A - B, D - E: Stereo OFF Position.
B - D: Stereo ON Position (indicator lighting).
C: Adjust Point of Pilot Circuit.

Fig. 5 (Abb. 5)

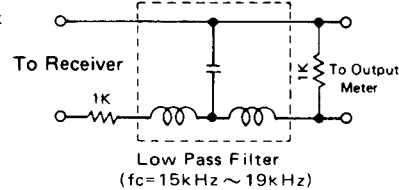

Fig. 6 (Abb. 6)

ALIGNMENT INSTRUCTIONS (FM/AM tuner circuitry) ENGLISH

SIGNAL GENERATOR		DIAL SETTING	INDICATOR (AC VTVM or SCOPE) (DISTORTION METER)	ADJUSTMENT POINTS	REMARKS
CONNECTION	FREQUENCY				
AM ALIGNMENT					
1	High side through 0.001 μF to AM antenna trimmer terminal. Common to chassis.	455kHz (30% Mod. with 400Hz) (For United Kingdom to 470kHz)	Point of non-interference	Connect VTVM or scope to TP201. through 0.1 μF	T201 (1st IFT) Z201 (2nd IFT) ●Adjust for maximum output.
2	Fashion loop of several turns of wire and radiate signal into loop of receiver	600kHz (30% Mod. with 400Hz)	600kHz	Connect VTVM or scope to speaker terminals of receiver.	L202 (OSC Coil) L201 (ANT Coil) ●Adjust for maximum output. Adjust L201 by moving coil bobbin along ferrite core.
3	Fashion loop of several turns of wire and radiate signal into loop of receiver	1500kHz (30% Mod. with 400Hz)	1500kHz	Connect VTVM or scope to speaker terminals of receiver.	CT5 (OSC Trimmer) CT4 (ANT Trimmer) ●Adjust for maximum output. ●Repeat steps (2) and (3)
FM-IF ALIGNMENT					
4	No Signal	Point of non-interference.	Tuning meter of set.	T101 (DISCRI IFT) (A) Orange Core	●FM muting/mode switch to ON/FM AUTO ●Adjust for center position of tuning meter.
FM-RF ALIGNMENT					
5	Connect to FM 300 Ω antenna terminal through FM dummy antenna.	90MHz (100% Mod. with 400Hz)	90MHz	Connect scope to speaker terminals of receiver.	L5 (OSC Coil) L3 (RF-DET Coil) L1 (ANT Coil) ●FM muting/mode switch to OFF/FM MONO. ●Adjust for maximum amplitude and symmetrical curve. (Refer to fig. 4).
6	Connect to FM 300 Ω antenna terminal through FM dummy antenna.	106MHz (100% Mod. with 400Hz)	106MHz	Connect scope to speaker terminals of receiver.	CT3 (OSC Trimmer) CT2 (RF DET Trimmer) CT1 (ANT Trimmer) ●Adjust for maximum amplitude and symmetrical curve. ●Repeat steps (5) and (6).
FM MONO DISTORTION ALIGNMENT					
7	Connect to FM 300 Ω antenna terminal through FM dummy antenna. Apply 60 dB to set.	100MHz (100% Mod. with 400Hz)	100MHz	Connect distortion meter to speaker terminals of receiver.	T101 (DISCRI IFT) (B) Green Core ●Adjust for minimum distortion of left output. ●Repeat steps (4) and (7).
FM MUTING LEVEL ALIGNMENT					
8	Connect to FM 300 Ω antenna terminal through FM dummy antenna. Apply 16dB(6.3 μV) to set.	100MHz (100% Mod. with 400Hz)	100MHz	Connect VTVM or scope to speaker terminals.	VR102 ●FM muting/mode switch to "ON/FM AUTO" ●Adjust so that output can be obtained.
FM SIGNAL METER ALIGNMENT					
1 Apply 100MHz FM signal of 100dB (400Hz 30% modulation) to FM 300 Ω antenna terminal through FM dummy antenna.			3 Adjust VR101 for about 4.7 point of signal meter indication.		
2 Tuning at 100MHz.					
FM MPX PILOT ALIGNMENT					
Using a frequency counter			Using alternate system		
1 100MHz Non-modulated mono signal applied to set. (Apply 60dB)			1 Apply stereo signal from generator or stereo station to receiver.		
2 FM muting/mode switch to "ON/FM AUTO"			2 Adjust VR301 until stereo indicator lights up. Cement arm of VR301 as shown in fig. 4.		
3 Connect frequency counter to TP301 through resistor (100k Ω)					
4 Adjust VR301 to 19kHz. ±30Hz.					
Notes:					
1. Stereo modulator		● Connect stereo modulator output to EXT MOD terminal of signal generator.			
2. FM signal generator		● Pilot signal modulation to "10%" ● Frequency approximately 100MHz/Output level to "72dB (IHF)" ● Modulation mode to "FM"			
3. Selector switch to "FM"		● Connect stereo modulator output to EXT MOD terminal of signal generator.			
		● Modulation mode to "FM"			
		● Frequency approximately 100MHz/Output level to "72dB (IHF)"			
		● Modulation mode to "FM"			
		● Connect stereo modulator output to EXT MOD terminal of signal generator.			
		● Pilot signal modulation to "10%"			
		● Frequency approximately 100MHz/Output level to "72dB (IHF)"			
		● Modulation mode to "FM"			
		● Connect stereo modulator output to EXT MOD terminal of signal generator.			
		● Pilot signal modulation to "10%"			
		● Frequency approximately 100MHz/Output level to "72dB (IHF)"			
		● Modulation mode to "FM"			
FM SIGNAL GENERATOR CONNECTION					
FM SIGNAL GENERATOR CONNECTION	STEREO MODULATOR MODE & MOD RATE	INDICATOR (AC VTVM)	ADJUSTMENT POINT	REMARKS	
FM STEREO SEPARATION ALIGNMENT					
11	FM 300 Ω antenna terminals through FM dummy antenna.	(1kHz 30% Modulation) MODE L (and R) Pilot signal to "ON"	Connect VTVM to speaker terminals through low pass filter. (Refer to fig. 5)	VR302	●Tuning at 100MHz. ●Make adjustment so that, when the antenna input is subjected to L modulation (or R modulation), R channel output (or L channel output) becomes minimum.

ANWEISUNGEN FÜR ABGLEICHUNG (UKW/AM-Tunerkreis) — DEUTSCH

INSTRUCTIONS D'ALIGNEMENT (Circuit de Tuner FM/AM) — FRANÇAIS

(Für Deutschland)

AM/UKW MESSENDER		SKALENZEIGEREIN-STELLUNG DES TUNER	ANZEIGE (Wechselstrom Röhrevoltmeter oder Oszillograph bzw. Klirrfaktor-Meßgerät)	ABGLEICHSPUNKTE	BEMERKUNGEN
Anmerkungen: 1. Loudness-Schalter OFF 2. Bereichsschalter AM (AM Abgleich), FM (FM Abgleich) 3. FM Muting/mode-Schalter OFF/FM MONO 4. Lautsprecher-Schalter ON 5. Tape/Monitor-Umschalter SOURCE 6. Filter-Schalter OFF 7. Die Netzspannung auf ihren Sollwert einstellen. 8. Der Ausgang des Meßsenders darf nicht höher sein als unbedingt notwendig für eine gute Ablesung.					
AM-ABGLEICH					
1	Heißes Ende des Meßsenders über einen 0.001µF Kondensator an den AM Antenneneingang schließen. Kaltes Ende an Masse.	455kHz (400Hz Modul., 30%)	Kein Empfang	T201 (1. IFT) Z201 (2. IFT)	• Auf max. Ausgang abgleichen.
2	Das Meßsendersignal induktiv in den Tuner speisen. Hierzu behelfsmäßig eine Rahmenantenne fertigen und an den Eingang schließen.	600kHz (400Hz Modul., 30%)	600kHz	L202 (Osc. Spule) L201 (Ant. Spule)	• Auf max. Ausgang abgleichen. • L201 wird abgeglichen, indem die Spule am Ferritstab. entlanggeschoben wird.
3	Das Meßsendersignal induktiv in den Tuner speisen. Hierzu behelfsmäßig eine Rahmenantenne fertigen und an den Eingang schließen.	1500kHz (400Hz Modul., 30%)	1500kHz	CT5 (Osc. Trimmer) CT4 (Ant. Trimmer)	• Auf max. Ausgang abgleichen. • Schritt (2) und (3) sind zu wiederholen.
UKW ZF-ABGLEICH					
4		Kein Signal	Kein Empfang	T101 (Diskriminator IFT) [A]	• FM Muting-Schalter auf ON stellen. • Den Abstimmungsanzeiger auf den zentrum Wert einstellen.
UKW HF-ABGLEICH					
5	Meßsender über eine Kunstantenne an den UKW-Antenneneingang schließen.	87.5MHz (400Hz Modul., 100%)	87.5MHz (Frequenz Min.)	L5 (Osc. Spule)	• FM Muting-Schalter auf OFF stellen. • Auf max. Ausgang abgleichen.
6	Meßsender über eine Kunstantenne an den UKW-Antenneneingang schließen.	90MHz (400Hz Modul., 100%)	90MHz	L3 (Det. Spule) L1 (Ant. Spule)	• Auf max. Amplitude bei entsprechender Linearität abgleichen. (Vgl. Abb. 4)
7	Meßsender über eine Kunstantenne an den UKW-Antenneneingang schließen.	106MHz (400Hz Modul., 100%)	106MHz	CT3 (Osc. Trimmer) CT2 (Det. Trimmer) CT1 (Ant. Trimmer)	• Auf max. Amplitude bei entsprechender Linearität abgleichen. (Vgl. Abb. 4) • Schritt (5), (6) und (7) sind zu wiederholen.
ABGLEICH AUF MIN. VERZERRUNG IN STELLUNG UKW-MONO					
8	Meßsender über eine Kunstantenne an den UKW-Antenneneingang schließen.	100MHz (400Hz Modul., 100%)	100MHz	T101 (Diskriminator IFT) [B]	• Auf min. Verzerrung auf der Klirrfaktor-Meßbrücke über den Lautsprecher schließen. • Schritt (4) und (8) sind zu wiederholen.
UKW-MUTING-ABGLEICH					
9	Meßsender über eine Kunstantenne an den UKW-Antenneneingang schließen. Meßsender auf 16 dB (6.3µV) einstellen.	100MHz (400Hz Modul., 100%)	100MHz	VR102	• Muting Schalter auf "ON" stellen. • So einstellen, daß ein Ausgang zu vernehmen ist.
UKW-FELDSTÄRKEANZEIGE-ABGLEICH					
10	Meßsender über eine Kunstantenne an den UKW-Antenneneingang schließen. Meßsender für 100 dB (1HF) (ca. 100mV) einstellen.	100MHz (400Hz Modul., 30%)	100MHz	VR101	• VR101 auf ca. "4.7" der Feldstärkeanzeige einstellen.
UKW-STEREO-DEKODER-ABGLEICH					
Unter Verwendung eines Zählers			Alternativ-Meßmethode		
1. Unmoduliertes Mono-Signal 100 MHz in das Gerät speisen. 2. FM Muting-Schalter auf "ON /FM AUTO" stellen. 3. Zähler über einen Widerstand 100K ohm an TP301 schließen. 4. VR301 auf 19kHz ±30Hz einstellen.			1. Stereosignal entweder von einem Stereogenerator oder einem Sender einspeisen. 2. VR301 so einstellen, bis die Stereolampe auf leuchtet. Schleifer von VR301 sichern, wie in Abb. 5 gezeigt.		
KANALTRENNUNG-ABGLEICH					
Anmerkungen: 1. Stereo-Modulator Ausgang des Stereo-Modulators an den Eingang EXT MOD des Meßsenders schließen. Eingebauter Oszillator 1kHz/Pilotton-Modulation 10% 2. UKW Meßsender Auf etwa 100MHz einstellen. Ausgangspegel 72dB (1HF). Modulation FM 3. Bereichsschalter FM 4. Muting/Mode-Schalter ON/FM AUTO					
12	ANSCHLUSS DES UKW MESSENDERS	STEREO MODULATOR MODE oder MOD. RATE	ANZEIGE (Röhrevoltmeter oder Oszillograph)	ABGLEICHSPUNKTE	ANMERKUNGEN
	Meßsender über eine Kunstantenne an den UKW-Antenneneingang schließen.	L (und R) Modulation 30%	Röhrevoltmeter oder Oszillograph über Tiefpassfilter an den Tuner-Ausgang schließen. Vgl. Abb. 6.	VR302	• Auf min. Ausgang rechter (und linker) abgleichen.

BRANCHMENT	FREQUENCE	AIGUILLE SUR LE CADRAN	INDICATEUR ELECTRONIQUE COPE OU DISTORSIONMETRE)	POINTS DE REGLAGE	OBSERVATIONS	
ALIGNEMENT AM						
1	Côté chaud, à travers 0.001µF sur le trimmer de l'antenne AM, commum an shassis	455kHz (modulé à 30% par 400Hz)	Point sans signal	T201 (1 transfo FI) Z201 (2 transfo FI)	• Réglez au maximum de signal de sortie.	
2	Faire une boucle de quelques tours et rayonner le signal dans le cadre de l'ampli-tuner	600kHz (modulé à 30% par 400Hz)	600kHz	L202 (bobine OSC) L201 (bobine ANT)	• Réglez au maximum de signal de sortie. Réglez L201 en déplaçant la bobine le long du noyau de ferrite.	
3	Faire une boucle de quelques tours et rayonner le signal dans le cadre de l'ampli-tuner.	1500kHz (modulé à 30% par 400Hz)	1500kHz	CT5 (trimmer OSC) CT4 (trimmer ANT)	• Réglez au maximum de signal de sortie. • Recommencez les étapes (2) et (3).	
ALIGNEMENT FI-FM						
4		Sans signal	point sans signal	T101 (Transfo FI discr.) [A]	• Commutateur de silencieux sur ON. • Réglez pour atteindre position médiane sur l'indicateur d'accord.	
ALIGNEMENT RF-FM						
5	Branchez sur la prise d'antenne FM à travers une antenne fictive FM.	90MHz (modulé à 100% par 400Hz)	90MHz	L5 (bobine OSC) L3 (bobine DET) L1 (bobine ANT)	• Commutateur de silencieux sur OFF. • Réglez au maximum d'amplitude et de symétrie. (Voir fig. 7)	
6	Branchez sur la prise d'antenne FM à travers une antenne fictive FM.	106MHz (modulé à 100% par 400Hz)	106MHz	CT3 (trimmer OSC) CT2 (trimmer DET) CT1 (trimmer ANT)	• Réglez au maximum d'amplitude et de symétrie. (Voir fig. 7) • Recommencez les étapes (5) et (6)	
REGLAGE DE LA DISTORSION FM EN MONO						
7	Branchez sur la prise d'antenne FM à travers une antenne fictive FM.	100MHz (modulé à 100% par 400Hz)	100MHz	T101 (Transfo FI discr.) [B]	• Réglez au minimum d'indication du distorsio-mètre. Recommencez les étapes (4) et (7).	
REGLAGE DU SEUIL DU SILENCIEUX D'ACCORD						
8	Branchez sur la prise d'antenne FM à travers une antenne fictive FM. Niveau de sortie du générateur 16 dB (6.3µV).	100MHz (modulé à 100% par 400Hz)	100MHz	VR102	• Commutateur de silencieux sur "ON" • Réglez pour obtenir une lecture en sortie.	
REGLAGE DE L'INDICATEUR D'ACCORD FM						
9	Branchez sur la prise d'antenne FM à travers une antenne fictive FM. Niveau de sortie du générateur 100 dB (100mV).	100MHz (modulé à 100% par 400Hz)	100MHz	Indicateur d'intensité	VR101	• Réglez VR101 pour obtenir env. "4.7" points sur l'échelle d'intensité.
ALIGNEMENT DU PILOTE MULTIPLEX FM						
Avec un fréquencesmètre			Par un autre système			
1. Signal mono 100 MHz non modulé appliqué à l'appareil. 2. Commutateur de silencieux sur "ON/FM AUTO" 3. Branchez le fréquencesmètre sur TP301 à travers une résistance de 100kΩ. 4. Réglez VR301 sur 19kHz ±30Hz.			1. Appliquez à l'appareil un signal stéréo provenant d'un générateur ou de la réception d'un émetteur. 2. Réglez VR301 jusqu'à ce que l'indicateur de stéréophonie s'allume. Collez le curseur de VR301 comme indiqué sur la fig. 8.			
REGLAGE DE LA SEPARATION DES CANAUX						
Notes: 1. Modulateur stéréo Branchez sa sortie sur la prise EXT. MOD. du générateur. OSC interne 1kHz Modulation du signal pilote 10% 2. Générateur de signal Fréquence env. 100MHz, niveau de sortie 72dB (1HF), genre de modulation sur FM. 3. Commutateur de gamme FM 4. Commutateur de silencieux ON/FM AUTO						
BRANCHEMENT DU GENERATEUR DE SIGNAL	MODE DU MODULATEUR STEREO ET TAUX DE MODULATION	INDICATEUR (VOLTMETRE ELECTRONIQUE OU OSCILLOSCOPE)	POINTS DE REGLAGE	OBSERVATIONS		
11	Borne d'antenne FM à travers antenne fictive.	Gauche (et droite) à 30% de modulation.	VR302	• Réglez au minimum de sortie droite (et gauche) fig. 9.		

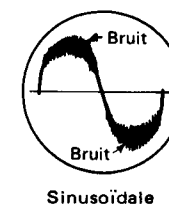

Fig. 7

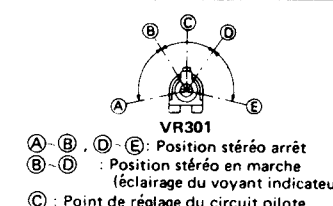

Fig. 8

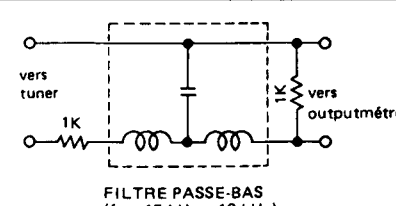
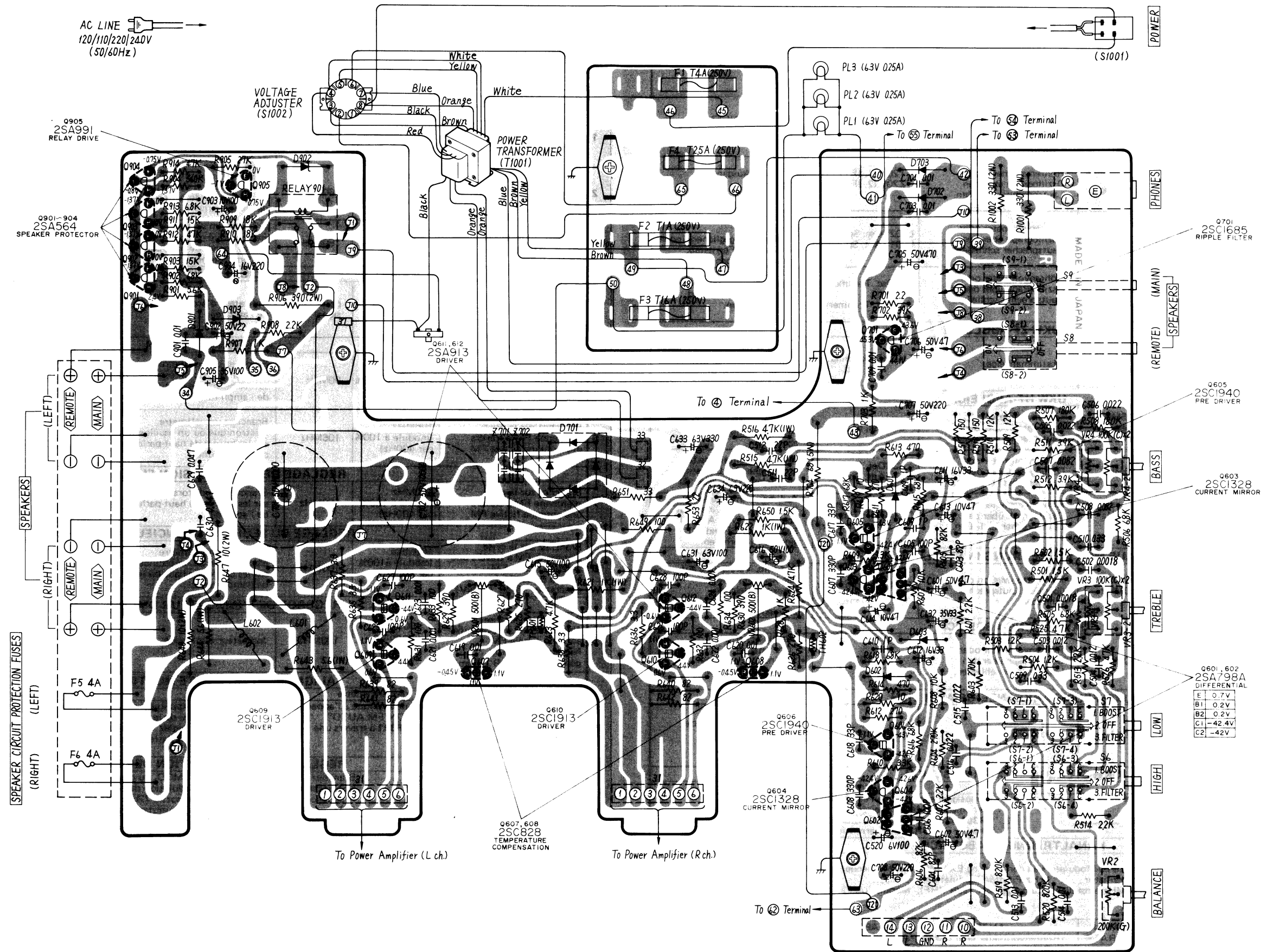

Fig. 9

MAIN AMPLIFIER & POWER SUPPLY CIRCUIT BOARD

Earth (Ground) Lines



FM/AM TUNER AND EQUALIZER CIRCUIT BOARD

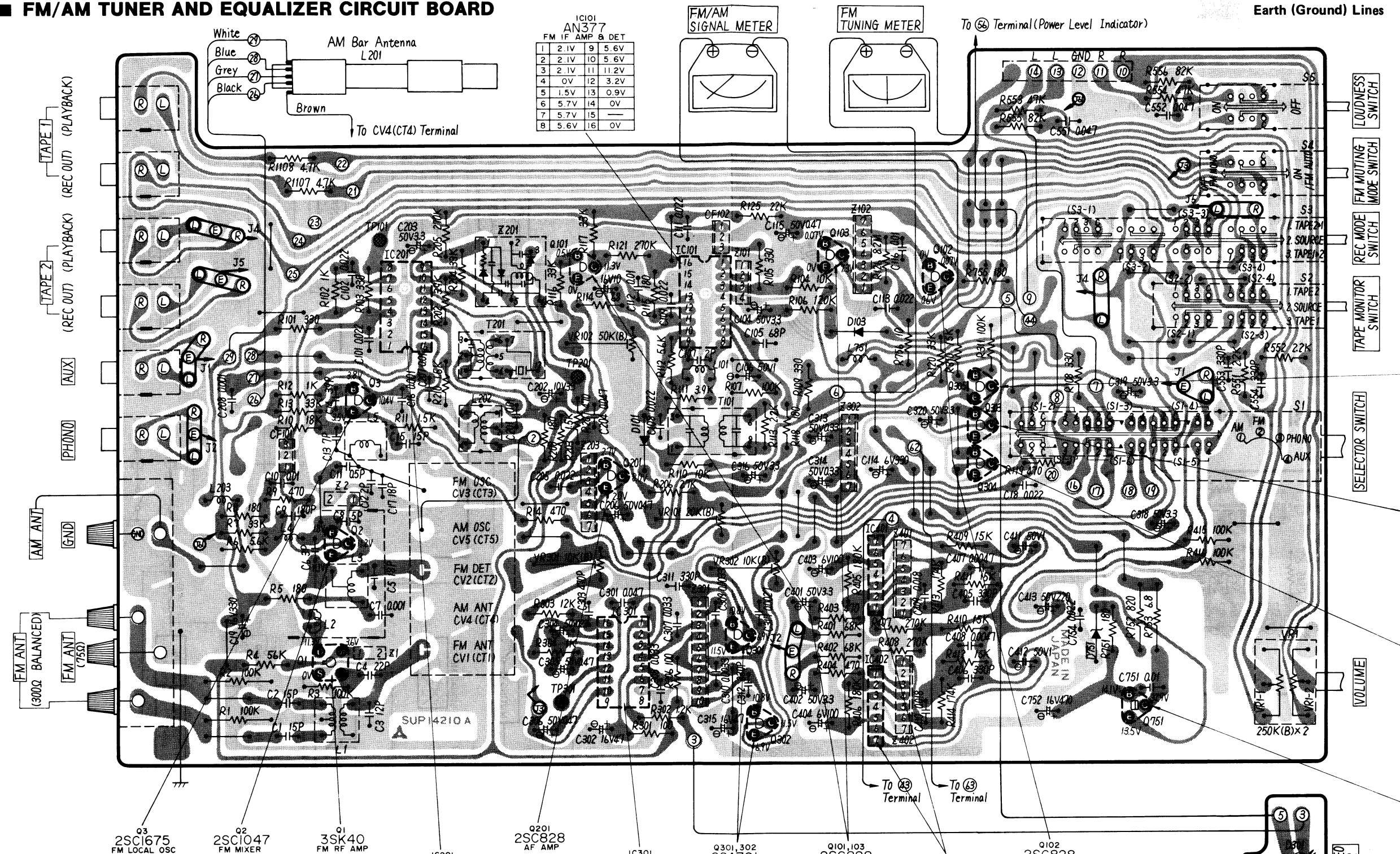

IC101
AN377
FM IF AMP & DET

1	2.1V	9	5.6V
2	2.1V	10	5.6V
3	2.1V	11	11.2V
4	0V	12	3.2V
5	1.5V	13	0.9V
6	5.7V	14	0V
7	5.7V	15	—
8	5.6V	16	0V

IC201
AN217
AM & FM 1st, 2nd IF AMP

1	FM	AM	FM	AM
2	0V	—	9	0.8V 7.7V
3	0V	—	10	1.1V 1.5V
4	5.8V	—	11	0.8V 1.3V
5	1.1V	—	12	0.8V 7.8V
6	0V	—	13	0.5V 0.7V
7	1.1V	—	14	0.8V 1.6V
8	5.5V	—	15	0.8V 7.8V
			16	0.5V 0.7V

IC301
AN363
FM MPX

1	11.2V	9	—
2	3.04V	10	1.9V
3	5.0V	11	1.9V
4	10.6V	12	1.5V
5	10.6V	13	1.9V
6	11.6V	14	1.9V
7	0V	15	1.9V
8	—	16	3.4V

IC401, 402
SV1A7129P
EQUALIZER AMP

1	2.0V	5	0.68V
2	0.64V	6	16.6V
3	0.07V	7	35.3V
4	0V		

POWER AMPLIFIER CIRCUIT BOARD
• Using same printed wiring boards for both channel
(Left and Right channel)

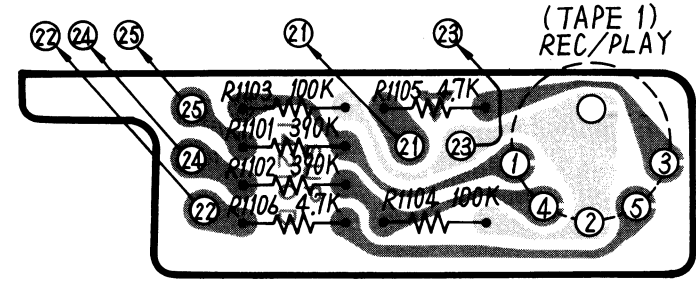
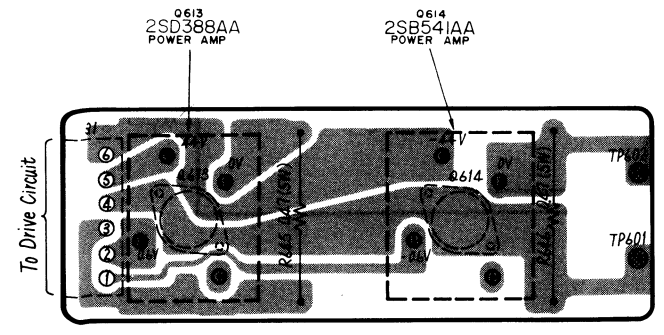

Q305
2SA564
SWITCHING

MUTING	MUTING
ON	OFF
E	0V 0.8V
C	0V 0.6V
B	0V 0.2V

Q303
2SC829A
SWITCHING

MUTING	MUTING
ON	OFF
E	0V 0V
C	0V 0.01V
B	0V 0.6V

Q304
2SC829A
SWITCHING

MUTING	MUTING
ON	OFF
E	0V 0V
C	0V 0.01V
B	0V 0.6V

Q751
1SC1398
REGULATOR

DIAL CORD INSTALLATION GUIDE

- For threading a fresh cord, proceed as follows.
 - Prepare a fresh cord more than 200cm(78-3/4") in length.
 - Bring the variable capacitor into a state where the drum is completely turned to the right (maximum capacity and lowest frequency for the variable capacitor).
 - Direct the cord in the order from 1 to 8.
 - Stretch the cord in such a tension as the spring length is elongated by 1.5 times that of the original state.
 - Fix the knot of the cord with the bond.

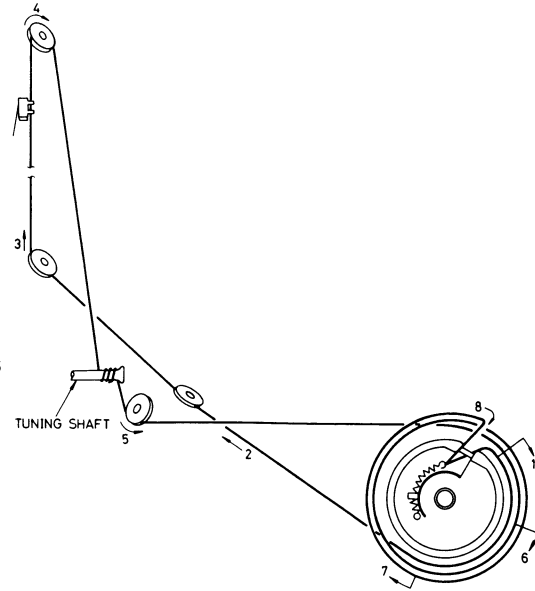

POWER LEVEL DISPLAY CIRCUIT BOARD

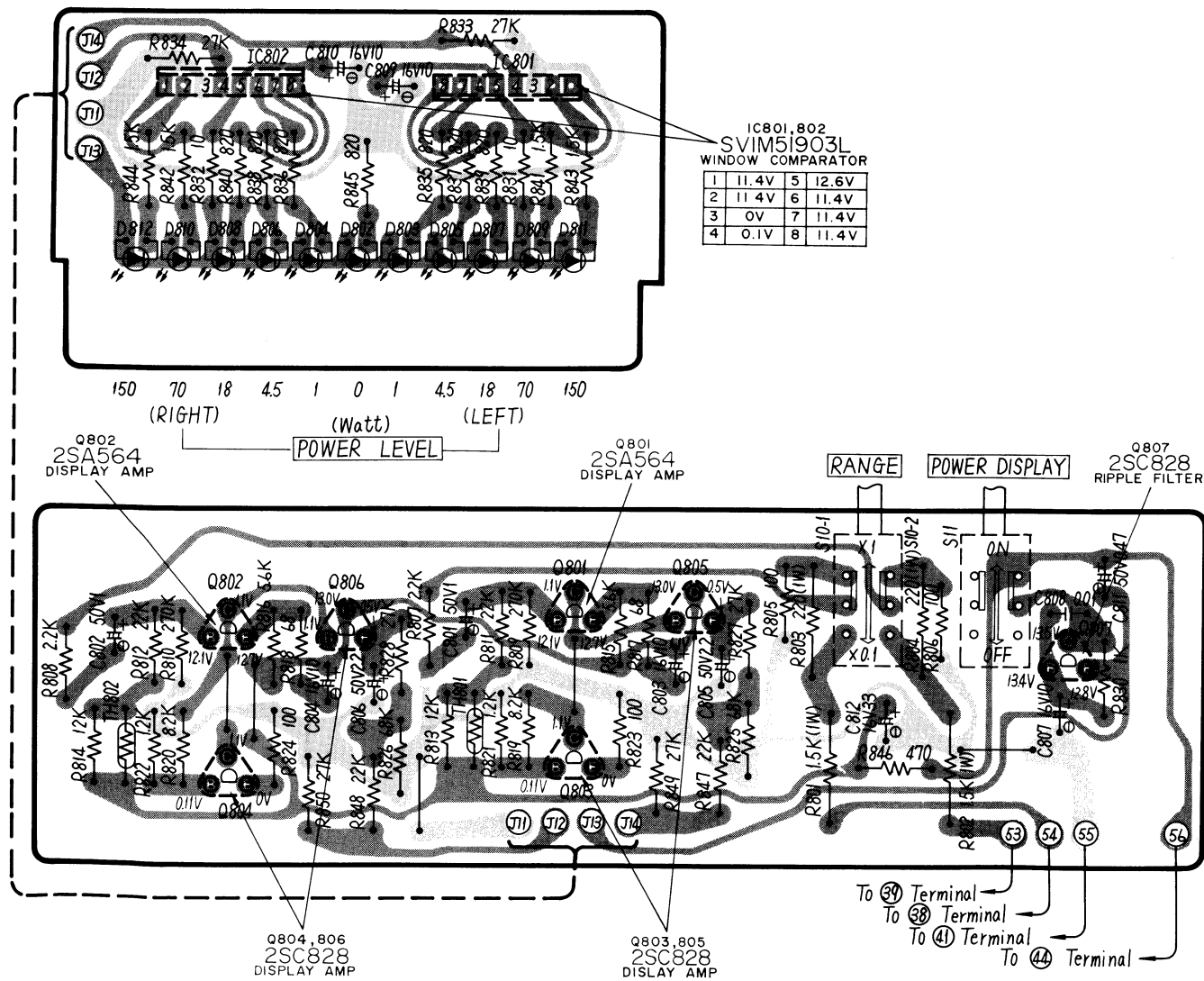

BLOCK DIAGRAM

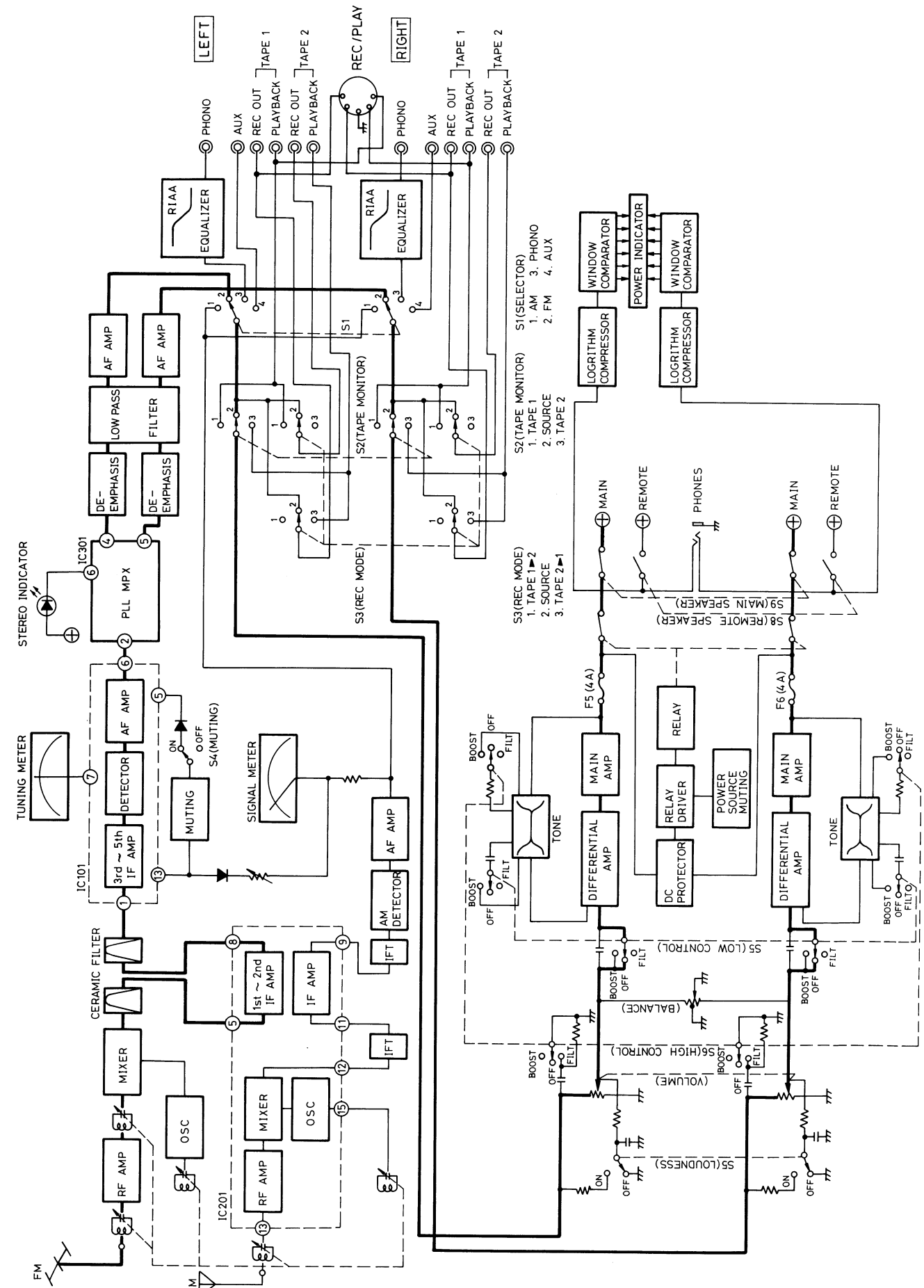

REPLACEMENT PARTS LIST

- NOTES 1:** 1. Part numbers are indicated on most mechanical parts.
Please use this part number for parts orders.
2. **S** indicates that only parts specified by the manufacturer be used for safety.

Ref. No.	Part No.	Part Name & Description	Per Set	Remarks
INTEGRATED CIRCUITS				
IC101	AN377	IC, FM IF Amplifier & FM Detector	1	
IC201	AN217P-BB	IC, FM IF Amplifier & AM Converter	1	
IC301	AN363	IC, FM Multiplex	2	
IC401, 402	SVITAT7129P	IC, Equalizer Amplifier	2	
IC801, 802	SVIM51903L	IC, Power Display Window Comparator	2	
TRANSISTORS				
Q1	3SK40-M	Transistor, FM RF Amplifier [FET]	1	
Q2	25C1047-C	Transistor, FM Mixer (Use in ranks C or D)	1	
Q3	25C1675-L1	Transistor, FM Local Oscillator	1	
Q101, 102, 103, 201	25C1328-T	Transistor, Muting Switch & AF Amplifier (Use in ranks S, T or U)	4	
Q301, 302	25A902S-F	Transistor, AF Amplifier (Use in ranks F or G)	2	
Q303, 304	25C829-C	Transistor, Muting Switching (Use in ranks A, B or C)	2	
Q305	25A666A1-R	Transistor, Muting Switching (Use in ranks P, Q or R)	1	
Q601, 602	25A798A-G2	Transistor, Differential Amplifier (Use in ranks F2 or G2)	2	
Q603, 604	25C1328-T	Transistor, Current Mirror (Use in ranks S, T or U)	2	
Q605, 606	25C1940-L	Transistor, Pre-Drive Amplifier (Use in ranks K or L)	2	
Q607, 608	25C828A-R	Transistor, Temperature Compensation (Use in ranks P, Q or R)	2	
Q609, 610	25C1913-R	Transistor, Driver Amp. (Use in ranks P, Q or R)	2	
Q611, 612	25A913-R	Transistor, Driver Amp. (Use in ranks P, Q or R)	2	
Q613 (X2)	25D388AA-R	Transistor, Power Amp. (Use in ranks Q, R or S)	2	
Q614 (X2)	25B541AA-R	Transistor, Power Amp. (Use in ranks Q, R or S)	2	
Q701	25C1685-T	Transistor, Ripple Filter (Use in ranks S or T)	1	
Q751	25C1398-Q	Transistor, Regulator (Use in ranks P, Q or R)	1	
Q801, 802	25A666A1-R	Transistor, Display Amplifier (Use in ranks P, Q or R)	2	
Q803, 804, 805, 806, 807	25C1328-T	Transistor, Display Amplifier & Ripple Filter (Use in ranks S, T or U)	5	
Q901, 902, 903, 904	25A666A1-R	Transistor, Speaker Protection (Use in ranks P, Q or R)	4	
Q905	25A991-F	Transistor, Relay Driver (Use in ranks E or F)	1	

Ref. No.	Part No.	Part Name & Description	Per Set	Remarks
DIODES				
D101	SVDKB262E	Diode, Meter Detector	1	
D103	MA150	Diode, Switching	1	
D301	LN25RP	Light Emitting Diode, Stereo Indicator	1	
D601, 602	MA27B	Diode, Current Mirror	2	
D603	SVDMZ324B	Diode, 24V Zener	1	
D701	SVDS10VB20	Diode, 24V Zener	1	
D702, 703	SM112	Rectifier	2	
D751	SVDMZ414	Diode, 14V Zener	1	
D802	LN36BP	Light Emitting Diode, Green	1	
D803 ~ D808	LN46YP	Light Emitting Diode, Orange	6	
D809 ~ D812	LN26RP	Light Emitting Diode, Red	4	
D901	SM112	Diode, Relay Pulse Killer	1	
D902	SVDMZ324B	Diode, 24V Zener	1	
D903	SVDMZ330B	Diode, 30V Zener	1	
COILS and TRANSFORMERS				
L1	SLA4P25	Coil, FM Antenna	1	
L2	RLQY25S2	Coil, Choke	1	
L3	SLD4P13	Coil, FM RF Detector	1	
L4	RLQY15G5	Coil, Choke	1	
L5	SLQ4P31	Coil, FM Local Oscillator	1	
L101	SLQX180-2	Coil, Choke	1	
L201	SLF2C11	Coil, AM Bar Antenna	1	
L202	SLO2C3-P	Coil, AM Local Oscillator	1	
L203	SLQX101-2D	Coil, Choke	1	
L601, 602	SLQY15G-3U	Coil, Power Amplifier Output	2	
L751	SLQX101-2D	Coil, Choke	1	
T101	SLI4D513-3	Transformer, FM IF Detector	1	
T201	SLI7D1013-M	Transformer, AM IF (455kHz)	1	
T201 (XE) only	SLI7D1013-M	Transformer, AM IF (470kHz)	1	
T1001	SLT5Q77	Transformer, Power Source	1	
T1001(XE) only	SLT5Q77-1	Transformer, Power Source	1	
COMPONENT COMBINATIONS				
Z1	EXRP102Z223C	Component Combination, 22kΩ & 0.001μF	1	
Z2	EXRP103P102C	Component Combination, 1kΩ & 0.01μF	1	
Z101	EXF3SL04C	Component Combination, 0.01μF (X3)	1	
Z102	EXBH85006K	Component Combination, 10kΩ, 22kΩ, 33kΩ, 56kΩ, 220kΩ	1	
Z201	SLI9F101-Z	Component Combination, AM Detector	1	
Z203	EXBH85005K	Component Combination, 1.5kΩ, 3.3kΩ, 47kΩ, 56kΩ, 180kΩ	1	
Z301	EXBH88007K	Component Combination, 390Ω (X2), 10kΩ (X4), 1.5kΩ (X2)	1	
Z302	EXA6YD04CL	Component Combination, 3.9kΩ (X2), 100kΩ (X2), 820pF (X2)	1	
Z401, 402	EXA6SD01C	Component Combination, 100Ω, 330Ω, 68pF, 150pF, 680pF (X2)	2	
Z701, 702	EXRFS203ZS	Component Combination, 0.01μF, (X2)	2	
CERAMIC FILTERS				
CF101, 102	SVFE107MS8-A	Ceramic Filter, Red, 10.7MHz	each 2	
	SVFE107MS8-B	Ceramic Filter, Blue, 10.67MHz		
	SVFE107MS8-C	Ceramic Filter, Orange, 10.73MHz		
	SVFE107MS8-D	Ceramic Filter, Black, 10.64MHz		
	SVFE107MS8-E	Ceramic Filter, White, 10.76MHz		
(Use pair ranks as same as CF101 and CF102.)				

NOTES 2:

Guide letters of Resistor and Capacitor indicate;

RESISTORS

ERD..... Carbon
 ERO..... Metal film
 ERF..... Non-flammable
 ERG..... Metal oxide
 ERX..... Metal film
 ERC..... Solid

CAPACITORS

ECC..... Ceramic
 ECQM..... Polyester
 ECE..... Electrolytic
 ECE.....N..... Non-Polar Electrolytic

Ref. No.	Part No.	Part Name & Description	Per Set	Remarks
THERMISTORS				
TH601, 602	RRT251	Thermistor, Main Amplifier	2	
TH801, 802	ERTD2FHL103S	Thermistor, Display Amplifier	2	
VARIABLE RESISTORS				
VR1	EWZF25BF5S	Volume Control, 250kΩ (B)	1	
VR2	EVH63F25G25S	Balance Control, 200kΩ (G)	1	
VR3, 4	EWK32F25C15S	Bass & Treble Control, 100kΩ (C)	2	
VR101	EVL3AA00B24	Meter Adjustment, 20kΩ (B)	1	
VR102	EVL3AA00B54	Muting Level Adjustment, 50kΩ (B)	1	
VR301	EVT33WA00B14	PLL VCO Adjustment, 10kΩ (B)	1	
VR302	EVL3AA00B14	Separation Adjustment, 10kΩ (B)	1	
VR601, 602	EVL3AA00B52	Power Amp ICQ Adjustment, 500Ω (B)	2	
VARIABLE CAPACITOR				
CV1 ~ CV5 (CT1 ~ CT5)	ECVC751K144A	Variable Capacitor, with Trimmer	1	
LAMPS				
PL1, 2, 3	XAMR62S	Lamp, Dial (6.3V 0.25A)	3	
FUSES				
F1	XBA2C40TR0	Fuse, T4A (250V), Primary	1	
F2	XBA2C10TR0	Fuse, T1A (250V), Secondary	1	
F3	XBA2C16TR0	Fuse, T1.6A (250V), Secondary	1	
F4	XBA2C20TR0	Fuse, T2A (250V), Primary	1	
F5, 6	XBA2C40S0	Fuse, 4A (250V), Speaker Circuit	2	
RELAY				
RLY901	SSY19-1	Relay, Speaker Protection	1	
SWITCHES				
S1	ESRM164F25E	Switch, Program Selector	1	
S2	SSL117	Switch, Tape Monitor	1	
S3	SSL115	Switch, Recording Mode	1	
S4, 5	SSL123	Switch, FM Muting/Mode & Loudness	2	
S6, 7	SSL119	Switch, High & Low Boost/Filter	2	
S8, 9	SSH223S	Switch, Main & Remote Speakers	1	
S10, 11	SSH219S	Switch, Power Display Range	1	
S1001	ESL21191	Switch, Power Source	1	
S1002	ESE37200	Switch, Voltage Adjustment	1	

Ref. No.	Part No.	Ref. No.	Part No.
RESISTORS			
R1, 2 (The products for (XAL) are not provided.)	ERD50TJ104	R303	ERD25TJ123
R3	ERD25TJ104	R304	ERD25TJ102
R4	ERD25TJ563	R306	ERD25TJ101
R5	ERD25TJ181	R310	ERD25TJ153
R6	ERD25TJ562	R401, 402	ERD25TJ104
R7	ERD25TJ333	R403, 404	ERO25CKG6802
R8	ERD25TJ181	R405, 406	ERD25TJ471
R9	ERD25TJ471	R407, 408	ERO25CKG1803
R10	ERD25TJ183	R409, 410	ERO25CKG2703
R11	ERD25TJ152	R411, 412	ERD25TJ153
R12	ERD25TJ102	R413, 414	ERO25CKF1502
R13	ERD25TJ333	R415, 416	ERO25CKF1743
R14	ERD25TJ471	R501, 502	ERD25TJ104
R101	ERD25TJ331	R503, 504	ERD25TJ152
R102	ERD25TJ102	R505, 506	ERD25TJ122
R103	ERD25TJ331	R507, 508	ERD25TJ682
R104	ERD25TJ103	R509, 510	ERD25TJ184
R105	ERD25TJ331	R511, 512	ERD25TJ123
R106	ERD25TJ124	R513, 514	ERD25TJ392
R107	ERD25TJ104	R515, 516	ERD25TJ222
R108, 109	ERD25TJ331	R517, 518	ERD25TJ392
R110	ERD25TJ103	R519, 520	ERD25TJ332
R111	ERD25TJ392	R525, 526	ERD25TJ824
R112	ERD25TJ562	R551, 552	ERD25TJ473
R113	ERD25TJ222	R553, 554	ERD25TJ222
R114	ERD25TJ680	R555, 556	ERD25TJ473
R115	ERD25TJ181	R601, 602	ERD25TJ823
R116, 117	ERD25TJ333	R603, 604	ERD25TJ222
R118	ERD25TJ181	R605, 606	ERD25TJ274
R119	ERD25TJ471	R607, 608	ERD25TJ823
R120	ERD25TJ333	R609, 610	ERD25TJ103
R121	ERD25TJ274	R611, 612	ERD25TJ332
R125	ERD25TJ223	R613, 614	ERD25TJ271
R126	ERC14GK825	R615, 616	ERD25TJ471
R202	ERD25TJ392	R617, 618	ERD25TJ683
R203	ERD25TJ152	R619, 620	ERD14FJ100
R204	ERD25TJ333	R621, 622	ERD14FJ102
R205	ERD25TJ274	R623, 624	ERD12FJ472
R206	ERD25TJ272	R625, 626	ERD25TJ331
R207	ERD25TJ471	R627, 628	ERD25TJ122
R208	ERD25TJ181	R629, 630	ERD25TJ471
R210	ERD25TJ152	R631, 632	ERD14FJ101
R301	ERD25TJ101	R633, 634	ERD14FJ101
R302	ERD25TJ122	R635, 636	ERD14FJ3R3
		R637, 638	ERD14FJ3R3
		R639, 640	ERD14FJ820

Ref. No.	Part No.
R641, 642	ERD14FJ820
R643, 644	ERX1ANJ5R6
R645, 646	ERF5AKR47
R647, 648	ERX2ANJ100
R649	ERD14FJ101
R650	ERD14FJ152
R651	ERD14FJ330
R653	ERD14FJ220
R701	ERD18FJ2R2
R702	ERD25TJ393
R703	ERD14FJ102
R704	ERF5SJ680
R751	ERD25TJ181
R752	ERG1ANJ821
R753	ERD12FJ6R8
R754	ERD25TJ152
R755	ERD25TJ181
R756	ERD25TJ100
R801, 802	ERG1ANJ152
R803, 804	ERG1ANJ221
R805, 806	ERD25TJ101
R807, 808	ERD25TJ222
R809, 810	ERD25TJ274
R811, 812	ERD25TJ223
R813, 814	ERD25TJ123
R815, 816	ERD25TJ562
R817, 818	ERD25TJ680
R819, 820	ERD25TJ822
R821, 822	ERD25TJ122
R823, 824	ERD25TJ101
R825, 826	ERD25TJ683
R827, 828	ERD25TJ273
R830	ERD25TJ102
R831, 832	ERD25TJ100
R833, 834	ERD25TJ273
R835, 836	ERD25TJ821
R837, 838	ERD25TJ821
R839, 840	ERD25TJ821
R841, 842	ERD25TJ152
R843, 844	ERD25TJ821
R845	ERD25TJ471
R846	ERD25TJ471
R847, 848	ERD25TJ223
R849, 850	ERD25TJ273
R901	ERD25TJ562
R902	ERD25TJ683
R903	ERD25TJ153
R904	ERD25TJ564
R905	ERD25TJ273
R906	ERG2ANJ391
R907	ERD12FJ102
R909, 910	ERD25TJ183
R911	ERD25TJ153
R912	ERD25TJ473
R913	ERD25TJ682
R914	ERD25TJ473
R1001, 1002	ERG2ANJ331
R1101, 1102	ERD25TJ894
R1103, 1104	ERD25TJ104
R1105 ~ 1108	ERD25TJ472

Ref. No.	Part No.
CAPACITORS	
C1, 2	ECCD1H150KC
C3	ECCD1H120KC
C4	ECCD1H220KC
C5	ECCD1H180KR
C6	ECCD1H300CC
C7	ECKD1H102MDA
C8	ECCD1H050CC
C9	ECCD1H181K
C10	ECKD1H103ZF
C11	ECCD1H055CC
C12	ECCD1H020CC
C13	ECCD1H070DC
C14	ECCD1H390KC
C15	ECCD1H150KC
C16	ECKD1H102ZF
C17	ECCD1H180KR
C18	ECKD1H223ZF
C19	ECEA1CS331
C51, 52 (XAL) only	ECKDHS101MB
C101, 102	ECEA2AS3R3
C104	ECCD1H223ZF
C105	ECCD1H680K
C106	ECEA2AS010
C107	ECCD1H020CC
C108, 109	ECCD1H223ZF
C110	ECEA1HS100
C111	ECKD1H223ZF
C112	ECKD1H103ZF
C113	ECCD1H223ZF
C114	ECEA1AS331
C115	ECEA2ASR47
C116	ECKD1H103ZF
C201	ECKD1H103MD
C202	ECEA1CS330
C203	ECEA2AS3R3
C204	ECCD1H473KZ
C205	ECCD1H223KZ
C206	ECEA2ASR47
C207	ECKD1H103ZF
C208	ECKD1H102ZF
C251 (XAL) only	ECKDHS102MD
C301	ECCD1H473KZ
C302	ECEA1ES470
C303	ECQ505471JZ
C304	ECEA50R22
C305	ECEA50ZR47
C306	ECEA50MR47R
C307, 308	ECQMIH333JZ
C309, 310	ECQMIH332KZ
C311, 312	ECQMIH331KB
C313, 314	ECEA50ZR33
C315	ECEA1ES470
C316	ECEA2AS3R3
C317	ECQMIH272KZ
C318, 319	ECEA50Z3R3
C320	ECEA2AS3R3
C401, 402	ECEA50M3R3R
C403, 404	ECEA1AS101

Ref. No.	Part No.
C405, 406	ECKD1H331KB
C407, 408	ECQP1472GZ
C409, 410	ECQP1183GZ
C411, 412	ECEA50M1TR
C413	ECEA1HS221
C501, 502	ECQM1H182KZ
C503, 504	ECQM1H123KZ
C505, 506	ECQM1H223KZ
C507, 508	ECQM1H823KZ
C509, 510	ECQM1H334KZ
C511, 512	ECCD1H220K
C513, 514	ECQM1H103KZ
C515, 516	ECQM1H223KZ
C520	ECEA1AS101
C551, 552	ECQM1H473KZ
C553, 554	ECKD1H331KB
C601, 602	ECEA50M4R7R
C603, 604	ECCD1H820K
C605, 606	ECCD1H101K
C607, 608	ECCD1H331K
C609, 610	ECCD1H010C
C611, 612	ECEA1CS330
C613, 614	ECEA1AS470
C615, 616	ECEA1HS101
C617, 618	ECCD1H330K
C619, 620	ECKD1H103ZF
C621, 622	ECKD1H102ZF
C623, 624	ECKD1H102KKB
C625, 626	ECCD2H101K
C627, 628	ECCD2H101K
C629, 630	ECQM1H473KZ
C631	ECEA1JS101
C632	ECEA1VS330
C633	ECEA1JS331
C634	ECEA1JS221
C701, 702	ECE150R103Z
C703, 704	ECKD1H103ZF
C705	ECEA1JS471
C706	ECEA1HS470
C707, 708	ECEA1HS221
C709	ECKD1H103ZF
C751	ECKD1H103ZF
C752	ECEA1CS471
C754	ECKD1H333ZF
C801, 802	ECEA2AS010
C803, 804	ECEA1HS100
C805, 806	ECEA2AS2R2
C807	ECEA1HS100
C808	ECKD1H103ZF
C809, 810	ECEA1HS100
C811	ECEA2ASR47
C812	ECEA1CS330
C901	ECKD1H103ZF
C902	ECEA50Z2R2
C903	ECEA1AS101
C904	ECEA16N220V
C905	ECEA1VS101

■ BLOCK DIAGRAM OF INTEGRATED CIRCUITS

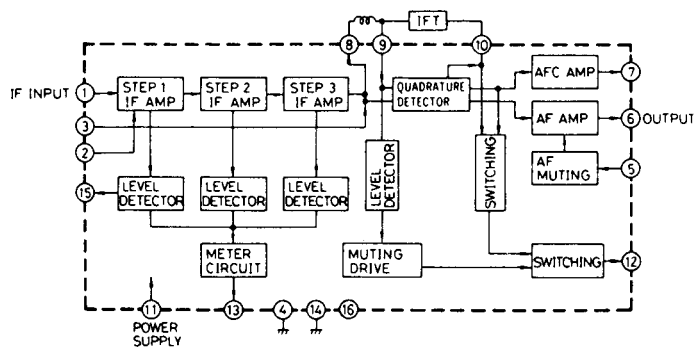

IC101 (AN377)
FM IF Amplifier & Detector

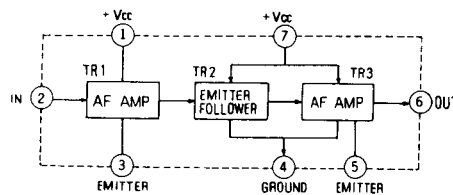

IC401, 402 (SVITA7129P)
Equalizer Amplifier

IC201 (AN217)
FM 2 Steps IF Amplifier
& AM Converter

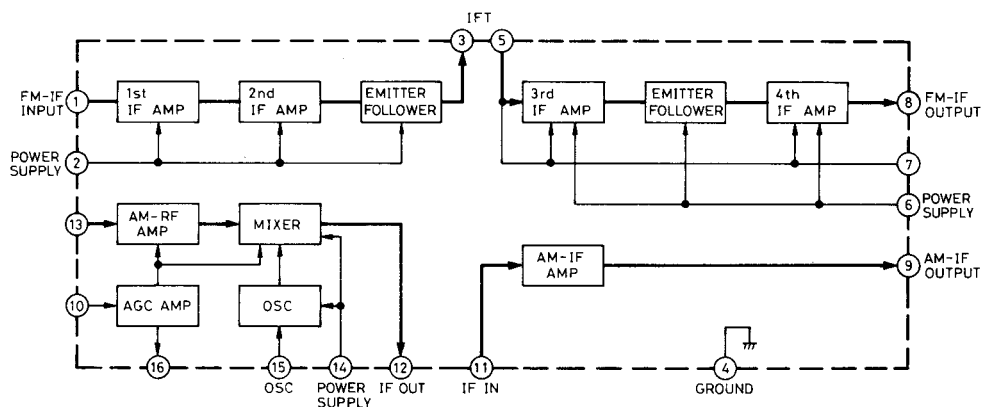

IC301 (AN363)
FM MPX

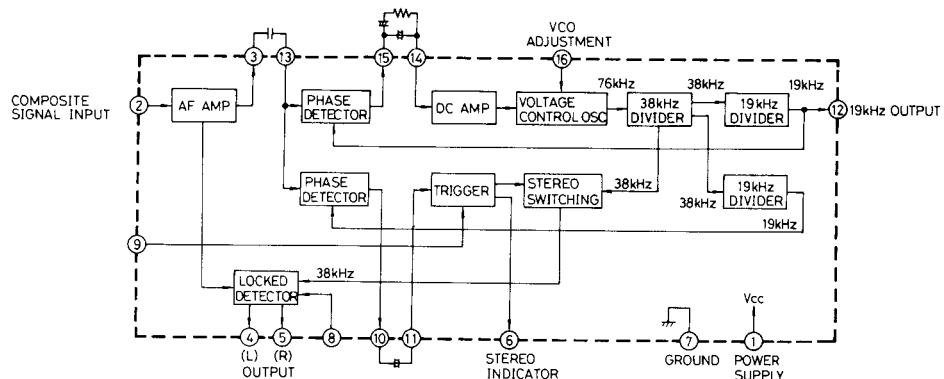

IC801, 802 (SVM51903L)
Window Comparator

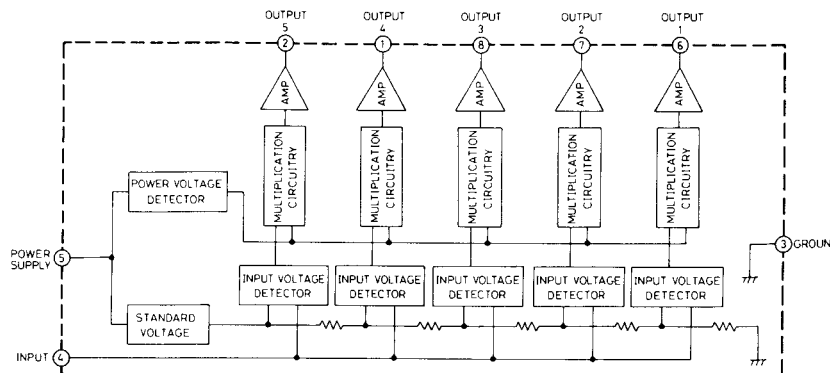

ANTENNA CAPACITORS

Product for XAL [Australia] only

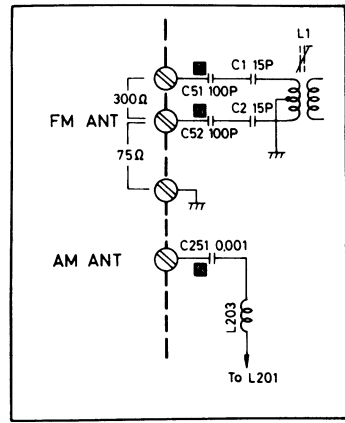

- Notes:**
- S1-1 ~ S1-6 : Selector switch in "AM" position.
 ① AM ↔ ② FM ↔ ③ PHONO ↔ ④ AUX
 - S2 : Tape Monitor switch in "SOURCE" position.
 ① TAPE 2 ↔ ② SOURCE ↔ ③ TAPE 1
 - S3 : Recording mode switch in "SOURCE" position.
 ① TAPE 2 ▶ 1 ↔ ② SOURCE ↔ ③ TAPE 1 ▶ 2
 - S4 : FM muting/Mode switch in "ON/FM AUTO" position.
 - S5 : Loudness switch in "OFF" position.
 - S6-1 ~ S6-4 : Acoustic high switch in "OFF" position.
 ① BOOST ↔ ② OFF ↔ ③ FILTER
 - S7-1 ~ S7-4 : Acoustic low switch in "OFF" position.
 ① BOOST ↔ ② OFF ↔ ③ FILTER
 - S8-1, S8-2 : Remote speakers switch in "OFF" position.
 - S9-1, S9-2 : Main speakers switch in "ON" position.
 - S10-1, S10-2 : Power display range switch in "X1" position.
 - S11 : Power display switch in "ON" position.
 - S1001 : Power source switch in "ON" position.
 - S1002 : Voltage adjustment switch in "240V" position.
 240V ↔ 220V ↔ 110V ↔ 120V
14. Indicated voltage values are the standard values for the unit measured by the DC electronic circuit tester (high impedance) with the chassis taken as standard. Therefore, there may exist some errors in the voltage values, depending on the internal impedance of the DC circuit tester.
- Not apply signal to set and muting switch to OFF condition
 - () AM signal reception.
 - └ FM muting switch is turned on under no-signal condition.
15. → AF Signal lines, ⇨ FM Signal lines → AM Signal lines.
16. This schematic diagram may be modified at any time with the development of new technology.
17. [S] indicates that only parts specified by the manufacturer be used for safety.

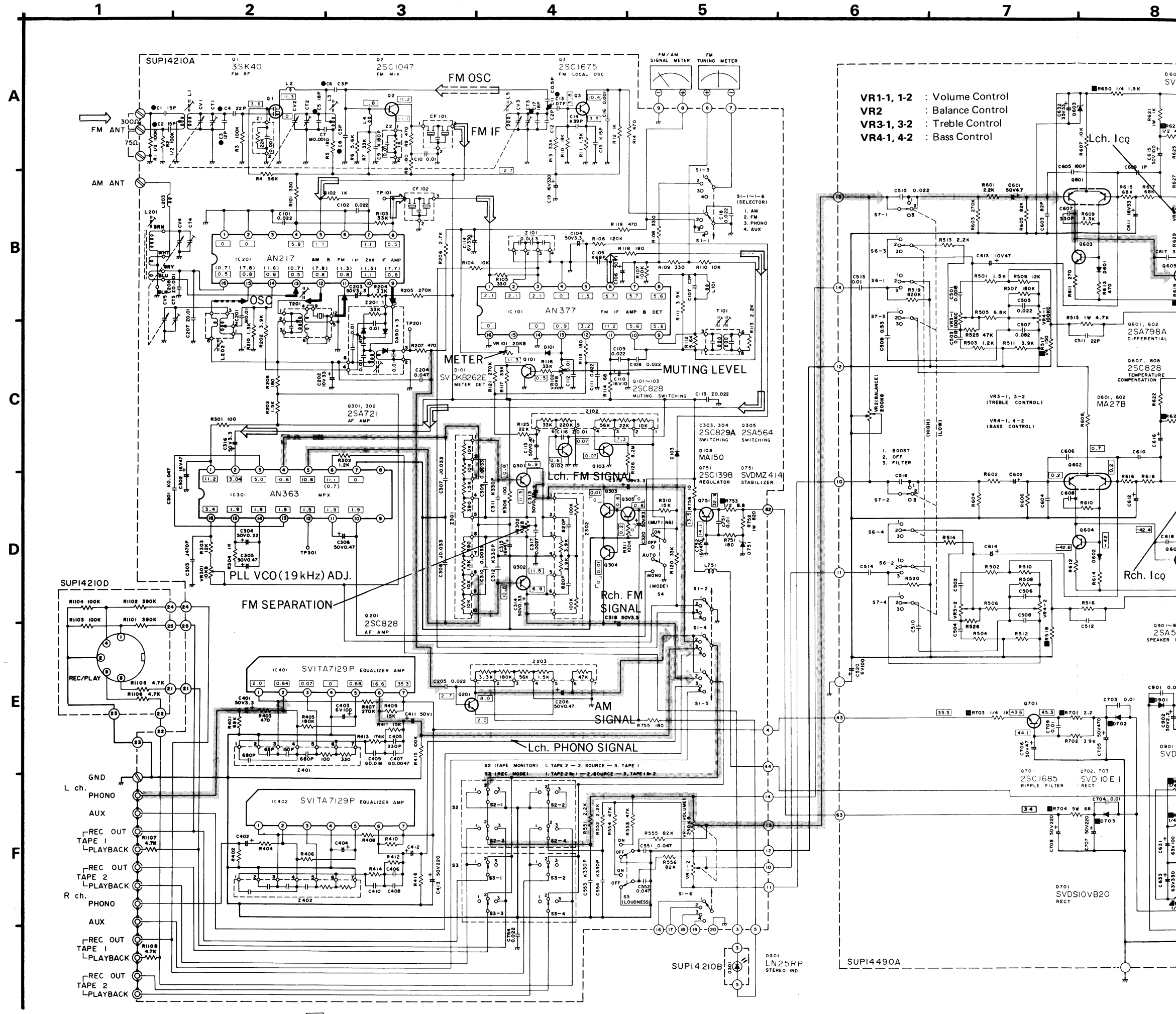

REPLACEMENT PARTS LIST Cabinet and chassis Parts

NOTES 1: 1. Part numbers are indicated on most mechanical parts.
Please use this part number for parts orders.
2. **S** indicates that only parts specified by the manufacturer be used for safety.

Ref. No.	Part No.	Part Name & Description	Per Set	Remarks
CABINET and CHASSIS PARTS				
1	SBN753	Knob, Volume	1	
2	SBN757	Knob, Tuning	1	
3	SHR9383	Spacer, Tuning Knob	1	
4	SBN755	Knob, Bass, Trable, Balance & Selector	4	
5	SBD7-2	Knob, Lever Switches	6	
5-1	SBD7-2A	Knob, Power Switch	1	
6	SGWA500D	Panel, Front Ass'y	1	○
7	XTB3+8BFZ	Screw, Front Panel M'tg	2	
8	XTS3+8CFZ	Screw, Front Panel M'tg	3	
9	SUS123-1	Spring, Push Switches	4	
10	SBC193	Button, Push Switches	4	
11	SSM133N	Meter, Signal & Tuning	1	
12	XNS8	Nut, Volumes & Selector	5	
13	XWV8	Washer, Volumes & Selector	5	
14	XNSS12	Nut, Headphones Jack M'tg	1	
16	XCJ6P21B-A	Headphones Jack	1	
17	SHS187	Shading Cloth, Lever Switches	7	
18	SDT8043-2	Shaft, Tuning	1	*
19	SKD3530	Scale, Dial	1	*
20	SDH471A	Plate, Dial	1	* ○
21	SGX6587	Bracket, Dial Scale Right Side	1	
22	SGX6589	Bracket, Dial Scale Left Side	1	
23	XTN3+10B	Screw, Dial Scale Bracket M'tg	2	
23-1	XWG3	Washer	4	
23-2	XTN3+10B	Screw, Dial Scale Bracket M'tg	1	
24	XTN3+12B	Screw, Dial Scale Bracket M'tg	1	
25	SDP1129	Pointer, Dial	1	*
26	SHP33	Sheet, Pointer Slider	1	
27	SDL19	Reflector Plate	1	
28	SDH473	Reflector Plate	1	*
29	XTB3+8B	Screw, Reflector Plate M'tg	2	
30	SHR9339	Spacer, Reflector Plate Screw	1	
30-1	SNW329	Washer	1	
31	SJS2101	Socket, Pilot Lamp	3	
31-1	RJR4B	Terminal Strip 2 Pin	1	
31-2	XTB3+8BFZ	Screw, Capacitor Bracket M'tg	1	
32	SHD3X1F	Screw, Pulley M'tg	4	*
33	SDR1	Pulley, Dial Cord	4	
34	SJS5611	Connector, 6 pin	1	
35	XSN4+12FZS	Screw, Power Transformer & Cabinet M'tg	8	
35-1	XWA4BFZ	Washer, Spring	8	
35-2	XWG4BFZ	Washer	8	
36	SMM31-1	Bracket, Meter	1	
37	RHG109	Rubber Cushion, AM Bar Antenna	2	
38	SDZ051-2	Cord, Dial 200cm (78-3/4")	1roll	
39	SDSA4121	Spring, Dial Cord	1	
40	SDD47-1	Drum, Variable Capacitor	1	
41	SJF8003	Terminal, Input & Antenna	1	
42	SJF8013-1	Terminal, Speakers	1	
43 (XE, DG) only	SGPA500E	Rear Panel, SGP1410B with Name plate (SGT16910)	1	○
43 (XA, X) only	SGP1410-1B	Rear Panel	1	○
43 (XAL) only	SGP1410-2B	Rear Panel	1	○
43	SGP1410B	Rear Panel	1	○
44	SJS6501	Socket, DIN (Tape Deck REC/PLAY)	1	
45	XTB3+8BFZ	Screw, Rear Panel M'tg	6	
46	SHR401-1	Latch, Speakers & Input Terminal M'tg	6	
47	SUV337	Cover, Speaker Fuses	1	*
48	XTB3+10BFZ	Screw, Speaker Fuse Cover M'tg	1	
49 (XA, X) only	SJS9205-1	Socket, AC Outlet	2	
50 (XA, X) only	XTN3+8BFZ	Screw, AC Outlet Socket M'tg	4	
51 (XE) only	SHR129	Bushing, AC Cord	1	
51 (XAL) only	SHR131	Bushing, AC Cord	1	
51	SHR127	Bushing, AC Cord	1	
52 (XE) only	RJA45ZC	AC Cord, Power Source	1	
52 (XAL) only	QFC1207M	AC Cord, Power Source (with Plug)	1	
52 (XSW) only	SJA111	AC Cord, Power Source (with Plug)	1	
52	SJA97	AC Cord, Power Source (with Plug)	1	
53 (XE) only	SKA10271W	Cabinet, Brown Colour	1	
53	SKA10270W	Cabinet, Black Colour	1	
55	XSN3+6FZS	Screw, Voltage Adjuster M'tg	2	
56	XWA3BFZ	Washer, Spring	2	
58	SYU157	Bottom Board	1	*
59	SKP61	Ventilation Plate, Bottom Board	1	
60	XTN3+10B	Screw, Ventilation Plate M'tg	2	
61	XTN3+12B	Screw, Ventilation Plate M'tg	2	
62	XTN3+10B	Screw, Set Foot M'tg	4	
62-1	XWG3	Washer	15	
63	SKX245-1	Foot, Set	4	
64	XTN3+10B	Screw, Bottom Board M'tg	7	
65	XSB3+16BNS	Screw, Power Transistors M'tg	8	
66	XWE3FN	Washer, Power Transistors Screw	8	
67	XWA3BFN	Washer (Spring), Power Transistors Screw	8	
68	SMX137	Mica Plate	4	
69	SJV1401-1	Socket, Power Transistors	4	

Ref. No.	Part No.	Part Name & Description	Per Set	Remarks
ACCESSORIES				
A1	SSA251	Cord, FM Indoor Antenna	1	
A2	XBA2C40SSO	Fuse, 4A (250V) Speaker Circuit	2	
A3 (XA, X) only	SJP5213-1	Plug Adapter, AC Power	1	
A4 (XA, X) only	SJP5215	Plug Adapter, AC Power	1	
PACKING PARTS				
P1	SPP567	Polyethylene Bage	1	
P2	SPS1733	Pad, Right & Left Side	2	
P2 (XE, XSW)only	SPS1735	Pad, Right & Left Side	2	
P3	SPS1639	Pad, Left Side	1	
P3 (XE, XSW)only	SPS1639-1	Pad, Left Side	1	
P4	SPS1641	Pad, Right Side	1	
P4 (XE, XSW)only	SPS1641-1	Pad, Right Side	1	
P5	SPG1563	Carton Box	1	○
P5 (XGF) only	SPG1565	Carton Box	1	○
P5 (XE, XSW)only	SPG1567	Carton Box	1	○
P6	SQF1941	Instructions Book, Printed Matter	1	○
P6 (XE, XAL, XA, X) only	SQF1943	Instructions Book, Printed Matter	1	○

NOTES 2: * (D) and (DG) are available in Scandinavia and European only. * (XE) is available in United Kingdom only.
* (XGH) is available in Holland only. * (XAL) is available in Australia only.
* (XGF) is available in France only. * (XA) and (X) are available in Asia, Latin America, Middle East and Africa only.
* (XSW) is available in Switzerland only.

ACCESSORIES

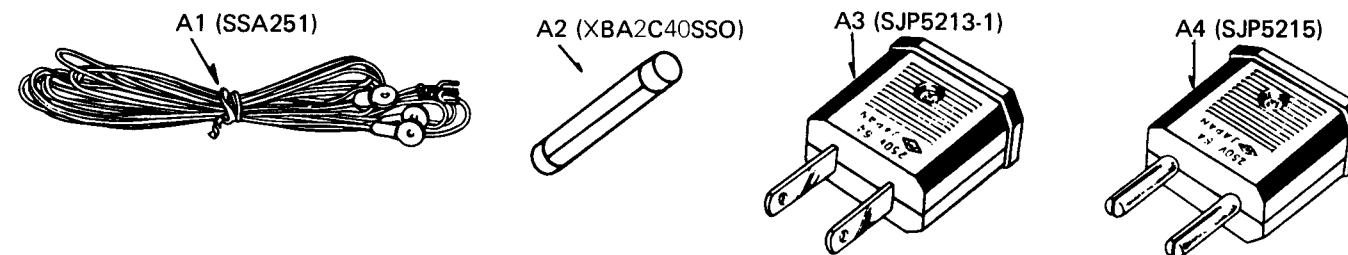

PACKINGS

