

# Service Manual

FM/AM Stereo Receiver

## SA-515

 (E), (EG), (XAL),  
(XA), (XGH), (EB)

## SA-515(K)

(E), (EG), (XGH)

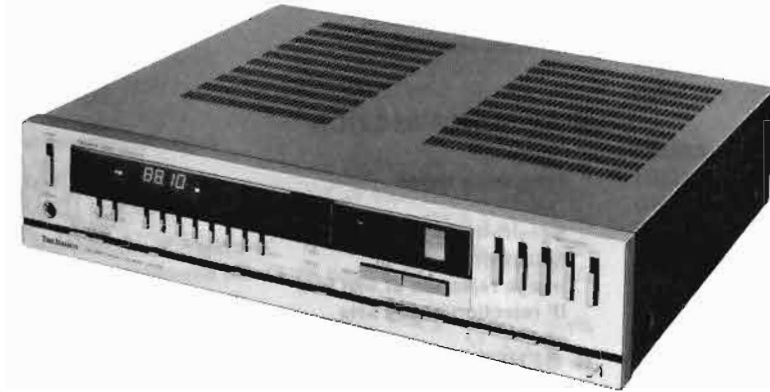

### Areas

- \* The cabinet, front panel and Knob are available in black color and silver types.
- \* The black type model is provided with (K) in the Service Manual.

- \* [E] and [EG] are available in Scandinavia and European except Belgium and Holland.
- \* [XAL] is available in Australia.
- \* [XA] is available in Asia, Latin America, Middle East and Africa.
- \* [XGH] is available in Holland.
- \* [EB] is available in Belgium.

### TECHNICAL SPECIFICATIONS (DIN 45 500)

(Specifications are subject to change without notice for further improvement.)

#### ■ AMPLIFIER SECTION

20 Hz~20 kHz continuous power output both channels driven	2 × 55W (4Ω) 2 × 50W (8Ω)
40 Hz~16 kHz continuous power output both channels driven	2 × 55W (4Ω) 2 × 50W (8Ω)
1 kHz continuous power output both channels driven	2 × 65W (4Ω) 2 × 55W (8Ω)
Total harmonic distortion	
rated power at 20 Hz~20 kHz	0.04% (4Ω) 0.02% (8Ω)
rated power at 40 Hz~16 kHz	0.04% (4Ω) 0.02% (8Ω)
rated power at 1 kHz	0.02% (4Ω) 0.02% (8Ω)
half power at 20 Hz~20 kHz	0.015% (8Ω)
half power at 1 kHz	0.005% (8Ω)
-26 dB power at 1 kHz	0.1% (4Ω)
50 mW power at 1 kHz	0.12% (4Ω)
Intermodulation distortion	
rated power at 250 Hz: 8 kHz=4:1, 4Ω	0.04%
rated power at 60 Hz: 7 kHz=4:1, SMPTE, 8Ω	0.02%
Power bandwidth	
both channels driven, -3 dB	5 Hz~35 kHz (4Ω) 5 Hz~40 kHz (8Ω)
Residual hum and noise	0.5 mV

Damping factor	15 (4Ω), 30 (8Ω)
Input sensitivity and Impedance	
PHONO	2.5 mV/47kΩ
AUX	150 mV/27kΩ
TAPE 2	150 mV/27kΩ
TAPE 1 REC/PLAY	180 mV/33kΩ
PHONO maximum input voltage (1 kHz, RMS)	150 mV
S/N	
rated power (4Ω)	
PHONO	73 dB (80 dB, IHF '66, 8Ω)
AUX, TAPE	88 dB (98 dB, IHF '66, 8Ω)
-26 dB power (4Ω)	
PHONO	64 dB
AUX, TAPE	66 dB
50 mW power (4Ω)	
PHONO	60 dB
AUX, TAPE	60 dB
Frequency response	
PHONO	RIAA standard curve ±0.3 dB (30 Hz~15 kHz)
AUX, TAPE	5 Hz~70 kHz (-3 dB) ±0.5 dB (20 Hz~20 kHz)
Tone controls	
BASS	50 Hz, +10 dB~ -10 dB
TREBLE	10 kHz, +10 dB~ -10 dB
Subsonic filter	30 Hz, -6 dB/oct.
High-cut filter	7 kHz, -6 dB/oct.
Loudness control (volume at -30 dB)	50 Hz, +9 dB
Muting	-20 dB

Output voltage	
TAPE 1, 2 REC OUT	150 mV
TAPE 1 REC/PLAY	30 mV/82k $\Omega$
Channel balance, AUX 250 Hz~6,300 Hz	$\pm 1.0$ dB
Channel separation, AUX 1 kHz	55 dB
Headphones output level and impedance	470 mV/330 $\Omega$
Load impedance	
MAIN or REMOTE	4 $\Omega$ ~16 $\Omega$
MAIN and REMOTE	8 $\Omega$ ~16 $\Omega$

## FM TUNER SECTION

Frequency range	87.50~108.00 MHz (50 kHz step) 87.9~107.9 MHz (200 kHz step)
Sensitivity	
S/N 30 dB	1.9 $\mu$ V (300 $\Omega$ ), 1.3 $\mu$ V (75 $\Omega$ )
S/N 26 dB	1.7 $\mu$ V (300 $\Omega$ ), 1.2 $\mu$ V (75 $\Omega$ )
S/N 20 dB	1.5 $\mu$ V (300 $\Omega$ ), 0.9 $\mu$ V (75 $\Omega$ )
IHF usable sensitivity	1.9 $\mu$ V (IHF '58)
IHF 46 dB stereo quieting sensitivity	22 $\mu$ V/75 $\Omega$
Total harmonic distortion (normal)	
MONO	0.1%
STEREO	0.3%
S/N	
MONO	68 dB (74 dB, IHF)
STEREO	64 dB (68 dB, IHF)
Frequency response	20 Hz~15 kHz, +1 dB~-2 dB
Alternate channel selectivity	
normal, $\pm 400$ kHz	75 dB
narrow, $\pm 300$ kHz	75 dB
Capture ratio (normal)	1.2 dB
Image rejection at 98 MHz	75 dB
IF rejection at 98 MHz	90 dB
Spurious response rejection at 98 MHz	100 dB
AM suppression	55 dB

Stereo separation (normal)	
1 kHz	45 dB
10 kHz	35 dB
Carrier leak	
19 kHz	-30 dB (-38 dB, IHF)
38 kHz	-50 dB (-50 dB, IHF)
Channel balance (250 Hz~6,300 Hz)	$\pm 1.5$ dB
Limiting point	1.2 $\mu$ V
Bandwidth (normal)	
IF amplifier	180 kHz
FM demodulator	1000 kHz
Antenna terminals	300 $\Omega$ (balanced) 75 $\Omega$ (unbalanced)

## AM TUNER SECTION

Frequency range	522~1611 kHz (9 kHz step) 530~1620 kHz (10 kHz step)
Sensitivity (S/N 20 dB)	30 $\mu$ V, 250 $\mu$ V/m
Selectivity	55 dB
Image rejection at 999 kHz	50 dB
IF rejection at 999 kHz	40 dB

## GENERAL

Power consumption	530W
Power supply	AC 50 Hz/60 Hz, 110V/120V/220V/240V
Dimensions (W·H·D)	430 x 97 x 382 mm (16-15/16" x 3-13/16" x 15-1/32")
Weight	10.1 kg (22.27 lb)

### Note:

Total harmonic distortion is measured by the digital spectrum analyzer (H.P. 3045 system).

## TECHNISCHE DATEN (DIN 45 500) (Spezifikationen Können infolge von Verbesserungen ohne Ankündigung geändert werden.)

### VERSTÄRKERTEIL

Dauerton-Ausgangsleistung bei 20 Hz ~ 20 kHz	
beide Kanäle ausgesteuert	2 x 55W (4 $\Omega$ ) 2 x 50W (8 $\Omega$ )
Dauerton-Ausgangsleistung bei 40 Hz ~ 16 kHz	
beide Kanäle ausgesteuert	2 x 55W (4 $\Omega$ ) 2 x 50W (8 $\Omega$ )
Dauerton-Ausgangsleistung bei 1 kHz	
beide Kanäle ausgesteuert	2 x 65W (4 $\Omega$ ) 2 x 55W (8 $\Omega$ )
Gesamtklirrfaktor	
Nennleistung bei 20 Hz ~ 20 kHz	0,04% (4 $\Omega$ ) 0,02% (8 $\Omega$ )
Nennleistung bei 40 Hz ~ 16 kHz	0,04% (4 $\Omega$ ) 0,02% (8 $\Omega$ )
Nennleistung bei 1 kHz	0,02% (4 $\Omega$ ) 0,02% (8 $\Omega$ )
halbe Nennleistung bei 20 Hz ~ 20 kHz	0,015% (8 $\Omega$ )
halbe Nennleistung bei 1 kHz	0,005% (8 $\Omega$ )
-26 dB Leistung bei 1 kHz	0,1% (4 $\Omega$ )
50 mW Leistung bei 1 kHz	0,12% (4 $\Omega$ )
Intermodulationsfaktor	
Nennleistung bei 250 Hz: 8 kHz = 4:1, 4 $\Omega$	0,04%
Nennleistung bei 60 Hz: 7 kHz = 4:1, nach SMPTE, 8 $\Omega$	0,02%
Leistungsbandbreite	
beide Kanäle ausgesteuert bei -3 dB	5 Hz ~ 35 kHz (4 $\Omega$ ) 5 Hz ~ 40 kHz (8 $\Omega$ )
Restbrumm und Geräusch	0.5 mV

Dämpfungsfaktor	15 (4 $\Omega$ ), 30 (8 $\Omega$ )
Eingangsempfindlichkeit und -impedanz	
Phono	2.5 mV/47 k $\Omega$
Aux	150 mV/27 k $\Omega$
Tape 2	150 mV/27 k $\Omega$
Tape 1 Aufnahme/Wiedergabe (TAPE 1 REC/PLAY)	180 mV/33 k $\Omega$
Maximale TA-Eingangsspannung (1 kHz, eff.)	150 mV
Geräuschabstand	
Nennleistung (4 $\Omega$ )	
Phono	73 dB (80 dB, nach IHF '66, 8 $\Omega$ )
Aux, Tape	88 dB (98 dB, nach IHF '66, 8 $\Omega$ )
-26 dB Leistung (4 $\Omega$ )	
Phono	64 dB
Aux, Tape	66 dB
50 mW Leistung (4 $\Omega$ )	
Phono	60 dB
Aux, Tape	60 dB
Frequenzgang	
Phono	RIAA-Standardkurve $\pm 0.3$ dB (30 Hz ~ 15 kHz)
Aux, Tape	5 Hz ~ 70 kHz (-3 dB) $\pm 0.5$ dB (20 Hz ~ 20 kHz)
Klangregler	
Baßregler (BASS)	50 Hz, +10 dB ~ -10 dB
Höhenregler (TREBLE)	10 kHz, +10 dB ~ -10 dB
Tiefenfilter	30 Hz, -6 dB/Okt.
Rauschfilter	7 kHz, -6 dB/Okt.
Gehörrechtliche Lautstärkekorrektur (Loudness)	
(bei -30 dB Ausgangsleistung)	50 Hz, +9 dB
Tondämpfung	-20 dB

<b>Ausgangsspannung</b>	
Tape 1/2 Aufnahme (Tape 1, 2 REC OUT)	150 mV
Tape 1 Aufnahme/Wiedergabe (TAPE 1 REC/PLAY)	30 mV/82 k $\Omega$
Kanalabweichung (Aux, 250 Hz ~ 6300 Hz)	$\pm 1,0$ dB
Übersprechdämpfung (Aux, 1 kHz)	55 dB
Kopfhörerpegel und -Impedanz	470 mV/330 $\Omega$
Lautsprecherimpedanz	
MAIN oder REMOTE	4 $\Omega$ ~ 16 $\Omega$
MAIN und REMOTE	8 $\Omega$ ~ 16 $\Omega$

### ■ UKW-TUNERTEIL

<b>Wellenbereich</b>	87,50 ~ 108,00 MHz (50 kHz step)
	87,9 ~ 107,9 MHz (200 kHz step)
<b>Eingangsempfindlichkeit</b>	
S/R 30 dB	1,9 $\mu$ V (300 $\Omega$ ), 1,3 $\mu$ V (75 $\Omega$ )
S/R 26 dB	1,7 $\mu$ V (300 $\Omega$ ), 1,2 $\mu$ V (75 $\Omega$ )
S/R 20 dB	1,5 $\mu$ V (300 $\Omega$ ), 0,9 $\mu$ V (75 $\Omega$ )
<b>Nutzempfindlichkeit nach IHF</b>	1,9 $\mu$ V (nach IHF '58)
<b>Stereoschalterschwelle bei 46 dB nach IHF</b>	22 $\mu$ V/75 $\Omega$
<b>Gesamtklirrfaktor (normal)</b>	
Mono	0,1%
Stereo	0,3%
<b>Geräuschabstand</b>	
Mono	68 dB (74 dB nach IHF)
Stereo	64 dB (68 dB nach IHF)
<b>Frequenzgang</b>	20 Hz ~ 15 kHz (+1 dB ~ -2 dB)
<b>Trennschärfe bei Störsender</b>	
normal, $\pm 400$ kHz	75 dB
schmal, $\pm 300$ kHz	75 dB
<b>Einfangverhältnis (normal)</b>	1,2 dB
<b>Spiegelfrequenz-Dämpfung bei 98 MHz</b>	75 dB
<b>ZF-Dämpfung bei 98 MHz</b>	90 dB
<b>Ansprechdämpfung auf Nebenfrequenzen bei 98 MHz</b>	100 dB

<b>AM-Unterdrückung</b>	55 dB
<b>Übersprechdämpfung (normal)</b>	
1 kHz	45 dB
10 kHz	35 dB
<b>Trägerrest</b>	
19 kHz	-30 dB (-38 dB nach IHF)
38 kHz	-50 dB (-50 dB nach IHF)
<b>Kanalabweichung (250 Hz ~ 6300 Hz)</b>	$\pm 1,5$ dB
<b>Begrenzerersatz</b>	1,2 $\mu$ V
<b>Bandbreite (normal)</b>	
ZF-Verstärker	180 kHz
UKW-Demodulator	1000 kHz
<b>Antennenanschluß</b>	300 $\Omega$ (symmetrisch)
	75 $\Omega$ (unsymmetrisch)

### ■ AM-TUNERTEIL

<b>Wellenbereiche</b>	522 ~ 1611 kHz (9 kHz step)
	530 ~ 1620 kHz (10 kHz step)
<b>Eingangsempfindlichkeit (S/R 20 dB)</b>	30 $\mu$ V, 250 $\mu$ V/m
<b>Trennschärfe</b>	55 dB
<b>Spiegelfrequenz-Dämpfung bei 999 kHz</b>	50 dB
<b>ZF-Dämpfung bei 999 kHz</b>	40 dB

### ■ ALLGEMEINE DATEN

<b>Leistungsaufnahme</b>	530 W
<b>Netzspannung</b>	Wechselstrom 50 Hz/60 Hz, 110V/120V/220V/240V
<b>Abmessungen (BxHxT)</b>	430 x 97 x 382 mm
<b>Gewicht</b>	10,1 kg

#### Bemerkung:

Der Gesamtklirrfaktor wurde mit einem digitalen Rauschspektrometer (Anlage H.P. 3045) gemessen.

## ■ CARACTERISTIQUES TECHNIQUES (DIN 45 500) (Sujet à changement sans préavis.)

### ■ SECTION AMPLIFICATEUR

<b>Puissance de sortie continue de 20 Hz~20 kHz, les deux canaux en circuit</b>	2 x 55W (4 $\Omega$ )
	2 x 50W (8 $\Omega$ )
<b>Puissance de sortie continue de 40 Hz~16 kHz, les deux canaux en circuit</b>	2 x 55W (4 $\Omega$ )
	2 x 50W (8 $\Omega$ )
<b>Puissance de sortie continue à 1 kHz les deux canaux en circuit</b>	2 x 65W (4 $\Omega$ )
	2 x 55W (8 $\Omega$ )
<b>Distorsion harmonique totale</b>	
à puissance nominale (20 Hz~20 kHz)	0,04% (4 $\Omega$ )
	0,02% (8 $\Omega$ )
à puissance nominale (40 Hz~16 kHz)	0,04% (4 $\Omega$ )
	0,02% (8 $\Omega$ )
à puissance nominale (1 kHz)	0,02% (4 $\Omega$ )
	0,02% (8 $\Omega$ )
à demi-puissance (20 Hz~20 kHz)	0,015% (8 $\Omega$ )
à demi-puissance (1 kHz)	0,005% (8 $\Omega$ )
puissance de -26 dB à 1 kHz	0,1% (4 $\Omega$ )
puissance de 50 mW à 1 kHz	0,12% (4 $\Omega$ )
<b>Distorsion d'intermodulation</b>	
à puissance nominale à 250 Hz: 8 kHz=4:1, 4 $\Omega$	0,04%
à puissance nominale à 60 Hz: 7 kHz=4:1, SMPTE, 8 $\Omega$	0,02%
<b>Réponse de fréquences</b>	
les deux canaux en circuit, -3 dB	5 Hz~35 kHz (4 $\Omega$ )
	5 Hz~40 kHz (8 $\Omega$ )
<b>Bruit et ronflement résiduels</b>	0,5 mV
<b>Coefficient d'amortissement</b>	15 (4 $\Omega$ ), 30 (8 $\Omega$ )

#### Sensibilité et impédance d'entrée

<b>PHONO</b>	2,5 mV/47k $\Omega$
<b>AUX (AUX)</b>	150 mV/27k $\Omega$
<b>BANDE 2 (TAPE 2)</b>	150 mV/27k $\Omega$
<b>BANDE 1, ENREGISTREMENT/LECTURE (TAPE 1 REC/PLAY)</b>	180 mV/33k $\Omega$
<b>PHONO (tension d'entrée maximum, 1 kHz RMS) Signal/Bruit</b>	150 mV
à puissance nominale (4 $\Omega$ )	
<b>PHONO</b>	73 dB (80 dB, IHF '66, 8 $\Omega$ )
<b>AUX, BANDE (AUX, TAPE)</b>	88 dB (98 dB, IHF '66, 8 $\Omega$ )
puissance de -26 dB (4 $\Omega$ )	
<b>PHONO</b>	64 dB
<b>AUX, BANDE (AUX, TAPE)</b>	66 dB
puissance de 50 mW (4 $\Omega$ )	
<b>PHONO</b>	60 dB
<b>AUX, BANDE (AUX, TAPE)</b>	60 dB
<b>Réponse de fréquence</b>	
<b>PHONO</b>	Courbe nominale RIAA
	$\pm 0,3$ dB (30 Hz~15 kHz)
<b>AUX, BANDE (AUX, TAPE)</b>	5 Hz~70 kHz (-3 dB)
	$\pm 0,5$ dB (20 Hz~20 kHz)
<b>Réglage de la tonalité</b>	
<b>BASSES (BASS)</b>	50 Hz, +10 dB ~ -10 dB
<b>AIGUS (TREBLE)</b>	10 kHz, +10 dB ~ -10 dB
<b>Filtre subsonique</b>	30 Hz, -6 dB/oct
<b>Filtre coupe-hauts</b>	7 kHz, -6 dB/oct
<b>Compensateur physiologique (volume à -30 dB)</b>	50 Hz, +9 dB
<b>Réglage silencieux</b>	-20 dB

Tension de sortie		
<b>SORTIE ENREGISTREMENT BANDE 1, 2</b>		
(TAPE 1, 2 REC OUT)	150 mV	
<b>ENREGISTREMENT/LECTURE BANDE 1</b>		
(TAPE 1 REC/PLAY)	30 mV/82k $\Omega$	
Equilibrage des canaux, AUX 250 Hz~6 300 Hz	$\pm 1,0$ dB	
Séparation des canaux, AUX 1 kHz	55 dB	
Niveau de sortie des casques et impédance	470 mV/330 $\Omega$	
Impédance de charge		
<b>PRINCIPALE ou AUXILIAIRE (MAIN or REMOTE)</b>	4 $\Omega$ ~16 $\Omega$	
<b>PRINCIPALE et AUXILIAIRE (MAIN and REMOTE)</b>	8 $\Omega$ ~16 $\Omega$	

## ■ SECTION SYNTONISATEUR FM

<b>Gamme de fréquence</b>	87,50~108,00 MHz (50 kHz step)
	87,9~107,9 MHz (200 kHz step)
<b>Sensibilité</b>	
S/B 30 dB	1,9 $\mu$ V (300 $\Omega$ ), 1,3 $\mu$ V (75 $\Omega$ )
S/B 26 dB	1,7 $\mu$ V (300 $\Omega$ ), 1,2 $\mu$ V (75 $\Omega$ )
S/B 20 dB	1,5 $\mu$ V (300 $\Omega$ ), 0,9 $\mu$ V (75 $\Omega$ )
Sensibilité utilisable IHF	1,9 $\mu$ V (IHF '58)
Sensibilité stéréo au seuil de 46 dB, IHF	22 $\mu$ V/75 $\Omega$
<b>Distorsion harmonique totale (normal)</b>	
MONO	0,1%
STEREO	0,3%
<b>Signal/Bruit</b>	
MONO	68 dB (74 dB, IHF)
STEREO	64 dB (68 dB, IHF)
<b>Réponse de fréquence</b>	20 Hz~15 kHz, +1 dB~-2 dB
<b>Sélectivité alternée par canal</b>	
Normal, $\pm 400$ kHz	75 dB
Étroite, $\pm 300$ kHz	75 dB
<b>Taux de capture (normal)</b>	1,2 dB
<b>Rejection d'image à 98 MHz</b>	75 dB

<b>Rejection FI à 98 MHz</b>	90 dB
<b>Rejection de réponse parasite à 98 MHz</b>	100 dB
<b>Suppression AM</b>	55 dB
<b>Séparation stéréophonique (normal)</b>	
1 kHz	45 dB
10 kHz	35 dB
<b>Fuite de porteuse</b>	
19 kHz	-30 dB (-38 dB, IHF)
38 kHz	-50 dB (-50 dB, IHF)
<b>Equilibrage de canaux (250 Hz~6,300 Hz)</b>	$\pm 1,5$ dB
<b>Point de limite</b>	1,2 $\mu$ V
<b>Largeur de bande (normal)</b>	
Amplificateur FI	180 kHz
Démodulateur FM	1000 kHz
<b>Bornes d'antenne</b>	300 $\Omega$ (symétrique)
	75 $\Omega$ (asymétrique)

## ■ SECTION SYNTONISATEUR AM

<b>Gamme de fréquence</b>	522~1611 kHz (9 kHz step)
	530~1620 kHz (10 kHz step)
<b>Sensibilité (S/B 20 dB)</b>	30 $\mu$ V, 250 $\mu$ V/m
<b>Sélectivité</b>	55 dB
<b>Rejection d'image à 999 kHz</b>	50 dB
<b>Rejection FI à 999 kHz</b>	40 dB

## ■ DIVERS

<b>Consommation</b>	530W
<b>Alimentation</b>	CA 50 Hz/60 Hz, 110V/120V/220V/240V
<b>Dimensions (L x H x Pr)</b>	430 x 97 x 382 mm
<b>Poids</b>	10,1 kg

### Remarque:

On mesure la distorsion harmonique totale au moyen d'un analyseur de spectre digital (Système H.P. 3045).

## ■ CONTENTS

	Page
LOCATION OF CONTROLS . . . . .	5
BEFORE STARTING THE REPAIRING . . . . .	6
DISASSEMBLY INSTRUCTIONS . . . . .	6 ~ 8
ADJUSTMENT POINTS . . . . .	9
ADJUSTING INSTRUCTIONS (English) . . . . .	10 ~ 12
EINSTELLUNGSANWEISUNGEN (Deutsch) . . . . .	12 ~ 14
INSTRUCTIONS DE REGLAGE (Français) . . . . .	14 ~ 17
HOW TO REPLACE CHIPS . . . . .	17
BLOCK DIAGRAM . . . . .	18 ~ 20
BLOCK DIAGRAM OF IC'S . . . . .	21
VOLUME SWITCH (S17 and S18) . . . . .	22

	Page
VARIABLE RESISTORS . . . . .	22
REPLACEMENT PARTS LIST (Electrical Parts) . . . . .	23 ~ 26
EXPLODED VIEWS . . . . .	27, 28
REPLACEMENT PARTS LIST (Cabinet and Chassis Parts) . . . . .	29
ACCESSORIES . . . . .	29
SCHEMATIC DIAGRAM . . . . .	30 ~ 36
PRINTED CIRCUIT BOARDS . . . . .	37 ~ 40
SCHEMATIC DIAGRAM . . . . .	41 ~ 44
PRINTED CIRCUIT BOARDS . . . . .	45, 46
LOCATION OF P.C.B. . . . .	47
TERMINAL GUIDE OF TRANSISTORS AND IC'S . . . . .	46

LOCATION OF CONTROLS

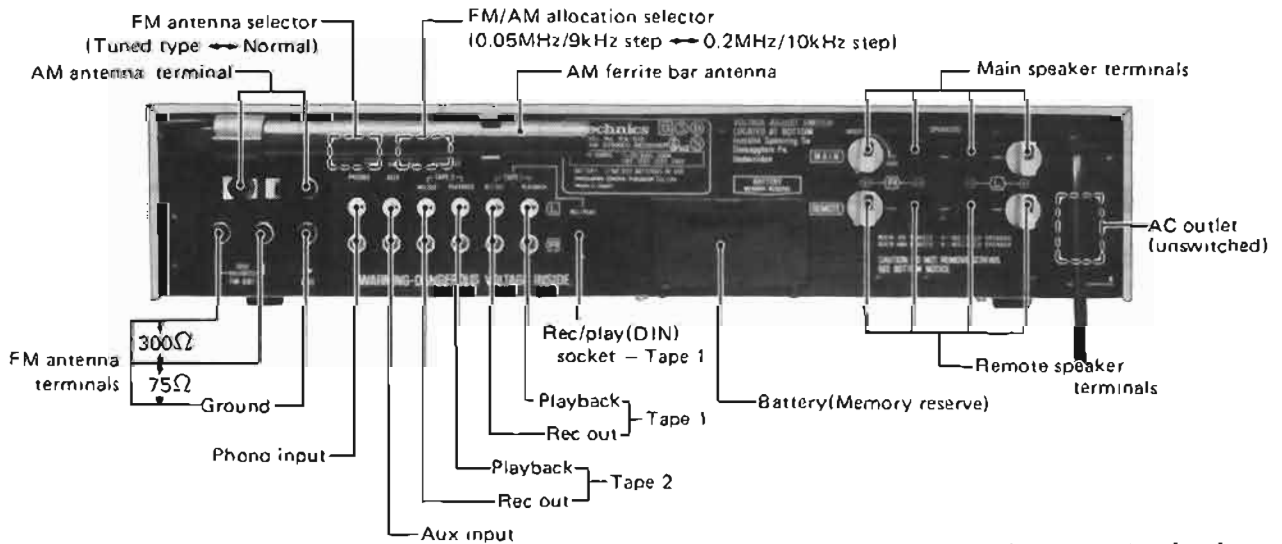
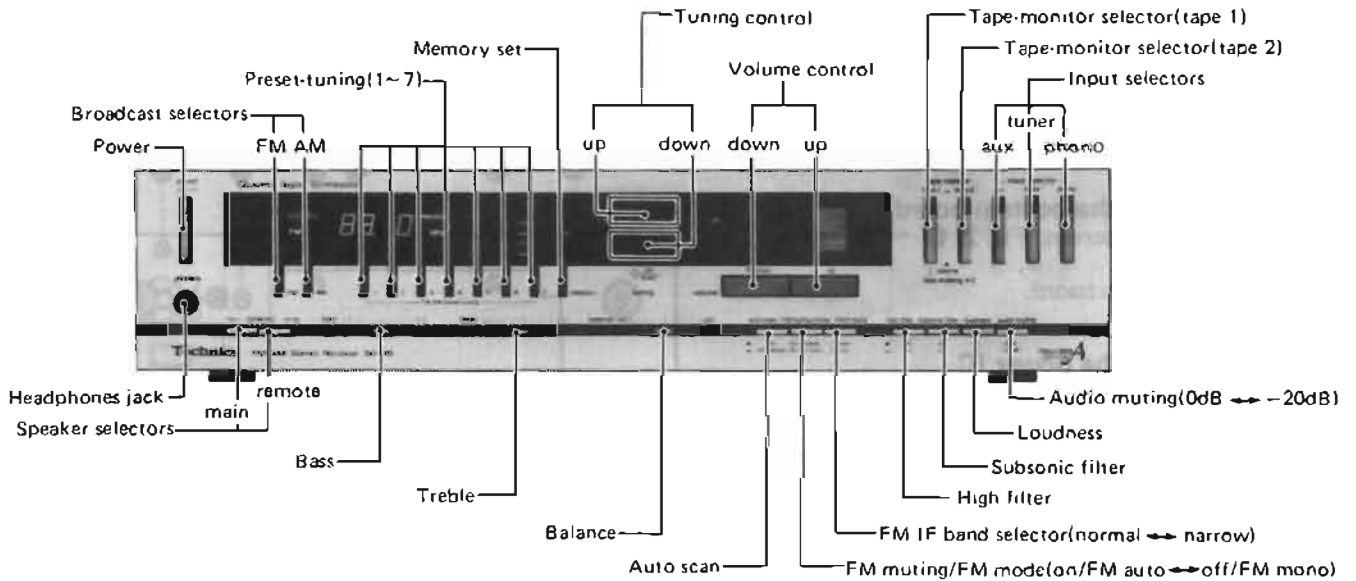
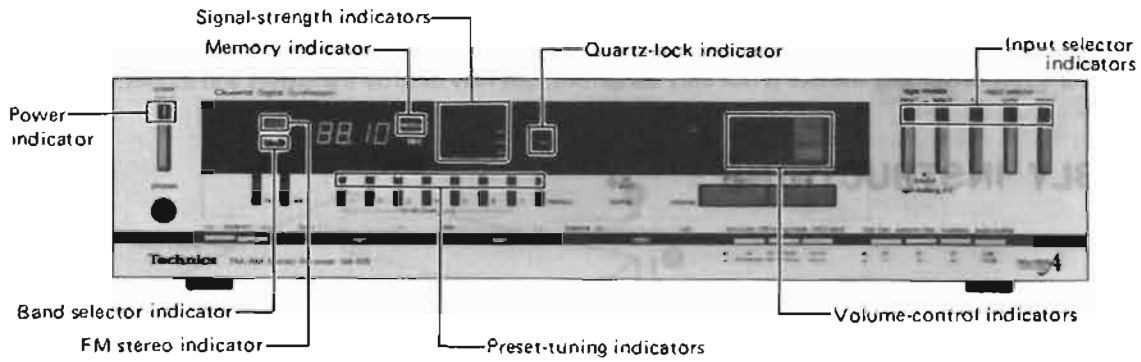

● The products for destination [XA] is equipped with AC outlet.

## BEFORE STARTING THE REPAIRING

Before adjusting or repairing, be sure to short-circuit opposite poles of the  $8200\mu\text{F}$  capacitors (C703 and C704) with a resistor approximately of " $50\Omega, 5\text{W}$ " for discharging the charged voltage. Short-circuiting with a screw driver and the like is not only dangerous, but may destroy transistors and diodes, and should therefore be avoided.

## DISASSEMBLY INSTRUCTIONS

### How to remove the cabinet

1. Remove the 4 setscrews (Fig. 1: ① ~ ④) of the cabinet.
2. Remove the cabinet.

### How to remove the front panel

1. Remove the 6 setscrews (Fig. 1: ⑤ ~ ⑩) of the front panel.
2. Slide the front panel in the direction of the arrow in Fig. 1 to detach the panel from the chassis.
3. As shown in Fig. 1, remove the 3 lugs to detach the LED indicator printed circuit boards from the back of the front panel.

### How to remove the bottom board

1. Remove the 14 setscrews (Fig. 2: ⑪ ~ ⑳) of the bottom board.
2. Remove the bottom board.

### How to remove the power IC

1. Remove the cabinet and bottom board. (Refer to the sections "How to remove the cabinet" and "How to remove the bottom board").
2. Unsolder of power IC for left channel or right channel. (Fig. 3)
3. Remove the 2 setscrews (Fig. 3: ⑳ ~ ㉑) (left) or ㉒ and ㉓ (right)) of the chassis.
4. Remove the heat-sink.
5. Remove the 2 setscrews (Fig. 4: ㉔) of the heat-sink.

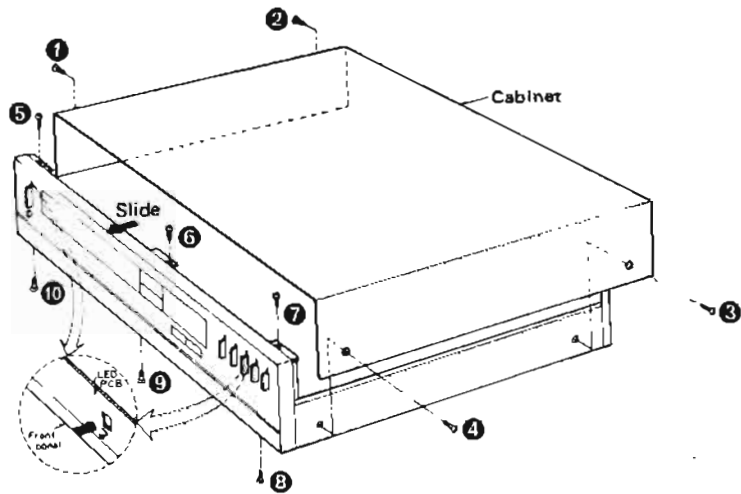

Fig. 1

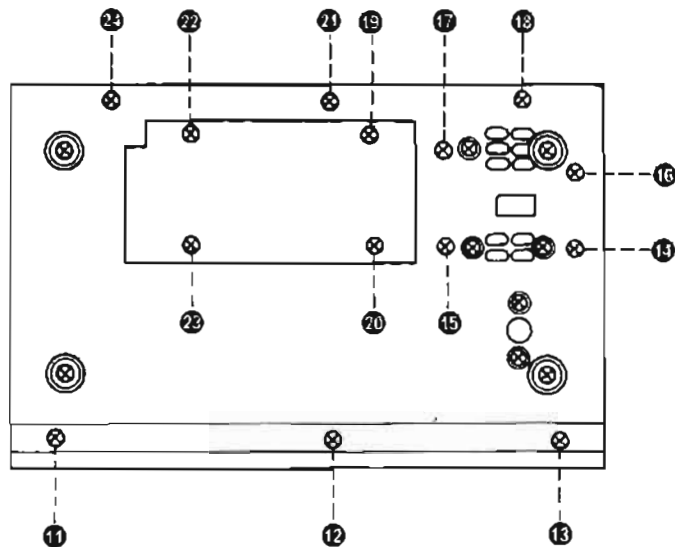

Fig. 2

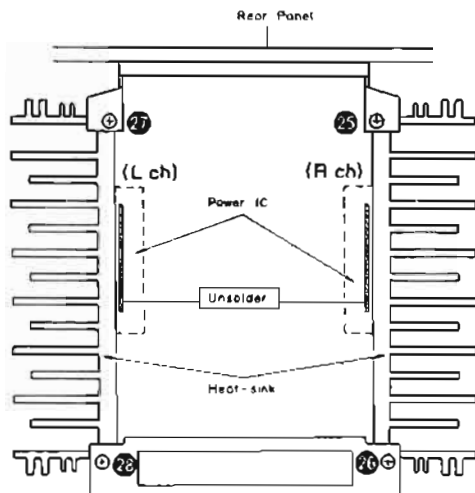

Fig. 3

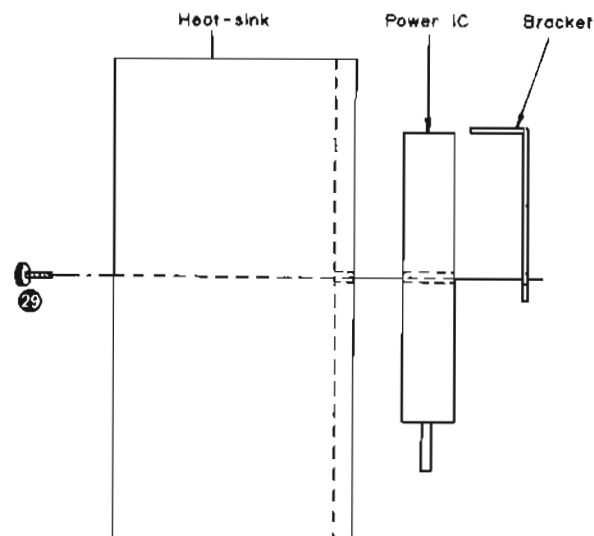

Fig. 4

● **How to remove the motor (volume level control)**

1. Remove the cabinet. (Refer to the section "How to remove the cabinet").
2. Remove the 2 setscrews (Photo 1: ④⑩ ~ ④⑪) and 6 connectors (Photo 1: ④⑫ ~ ④⑰) of the equalizer printed circuit board.
3. Remove the 2 setscrews (Photo 1: ④⑱ and ④⑲) of the chassis.
4. Remove the equalizer printed circuit board in the direction of the arrow in Photo 1.
5. Remove the 2 setscrews (Fig. 5: ④⑩ and ④⑪) of the film bracket.
6. Slide the film bracket in the direction of the arrow in Fig. 5.

**Note**

How to remove the volume indicator lamp  
 This lamp can be removed by pressing and turning counterclockwise.

7. Slide the volume gear in the direction of the arrow in Fig. 6 to detach the volume gear from the motor assy.
8. Remove the 1 nut (Fig. 6: ④⑫) of the volume control.
9. Unsolder of volume motor (Fig. 7: ④A ~ ④D).
10. Remove the volume motor in the direction of the arrow in Fig. 7.

**Notes**

How to install the volume film  
 1. Fully turn the volume gear clockwise, which is attached to the volume.  
 2. Wind the volume film around the volume gear and pulley (see Fig. 5 and Fig. 6), then secure it with the film fixing plate.  
 In this case, the volume film should be positioned so that the initial hole of the film is engaged with the gear. (Refer to Fig. 5)

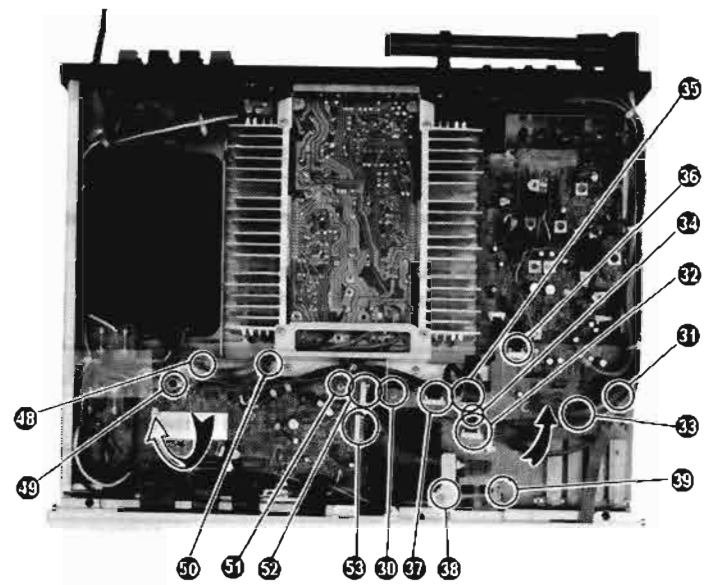

Photo 1

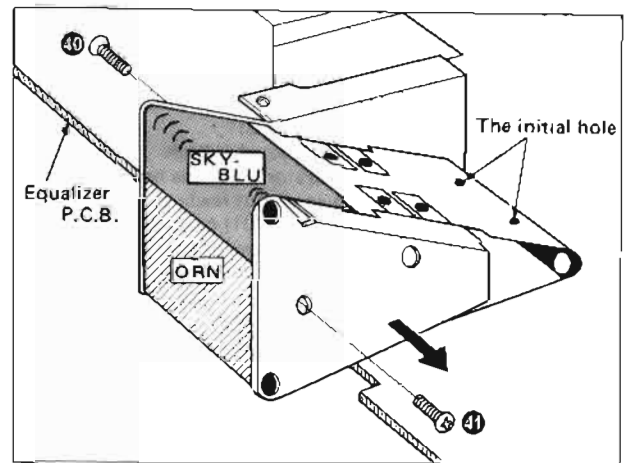

Fig. 5

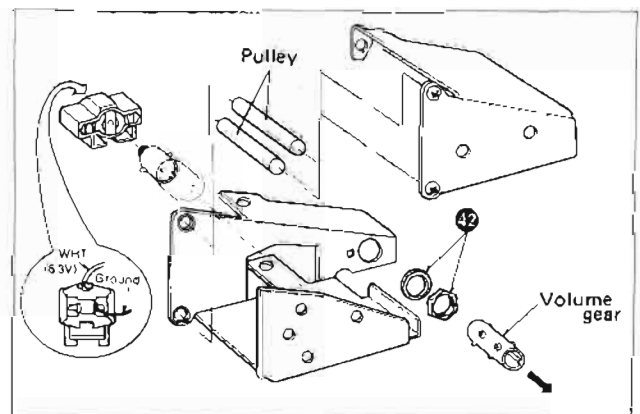

Fig. 6

● **How to check the tone control printed circuit board**

1. Remove the cabinet, bottom board and front panel. (Refer to the section "How to remove the cabinet", "How to remove the bottom board" and "How to remove the front panel").
2. Remove the 2 screws (Photo 1: ④⑩ and ④⑪) and 6 connectors (Photo 1: ④⑫ ~ ④⑰) of the equalizer printed circuit board.
3. Remove the 2 screws (Photo 1: ④⑱ and ④⑲) of the chassis.
4. Remove the equalizer printed circuit board in the direction of the arrow in Photo 1.
5. Remove the 2 screws (Photo 2: ④⑳ and ④㉑) of the fluorescent display tube ornament.
6. Remove the 3 screws (Photo 3: ④㉒ ~ ④㉔) and 4 screws (Photo 1: ④㉕ and ④㉖) of the logic printed circuit board.
7. Remove the 2 connectors (Photo 1: ④㉗ and ④㉘) of the logic printed circuit board, and then lift the circuit board in the direction of the arrow in Photo 1.
8. Remove the 4 screws (Photo 4: ④㉙ ~ ④㉚) of the shield plate.
9. Remove the shield plate.

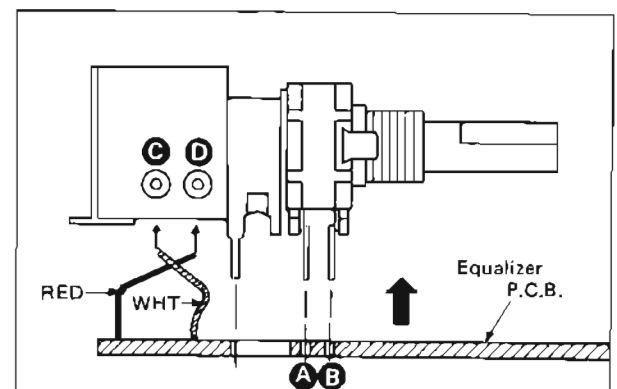

Fig. 7



Photo 2

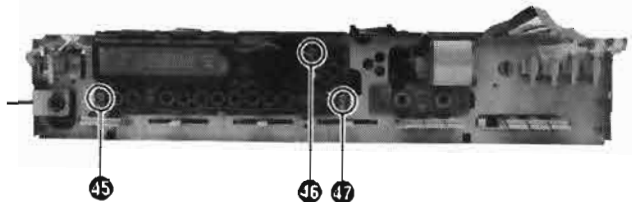

Photo 3

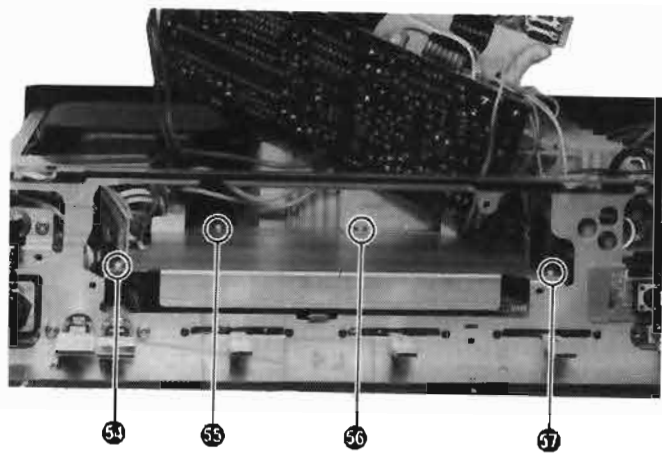

Photo 4

#### • Lead connector

1. To disconnect the lead wires from the lead connector, open the "lead holder" of the connector as shown in Fig. 8, and pull out the lead wires.
2. The lead wires are provided with identification colors or patterns as in Fig. 8. So, insert them into the connector in correct positions.
3. It is advisable to put pencil marks on both the leads and the connector beforehand for the convenience of insertion.

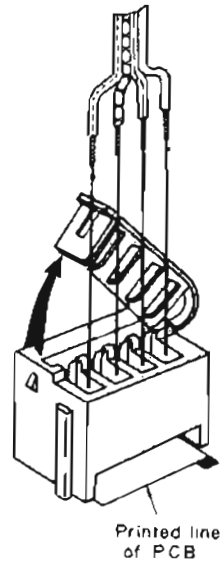
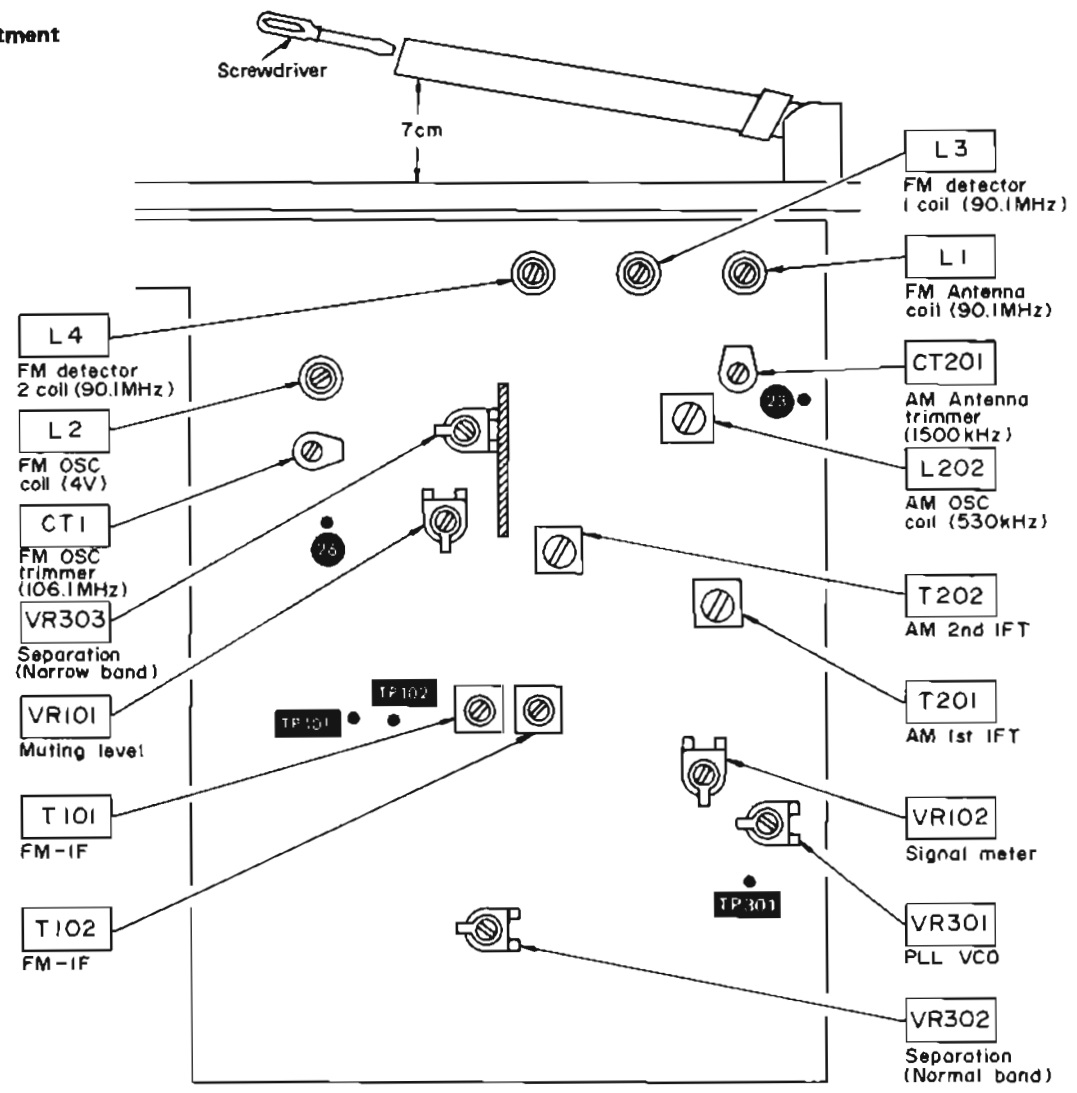

Fig. 8



# ADJUSTMENT POINTS

## • Tuner adjustment



## • Amplifier adjustment

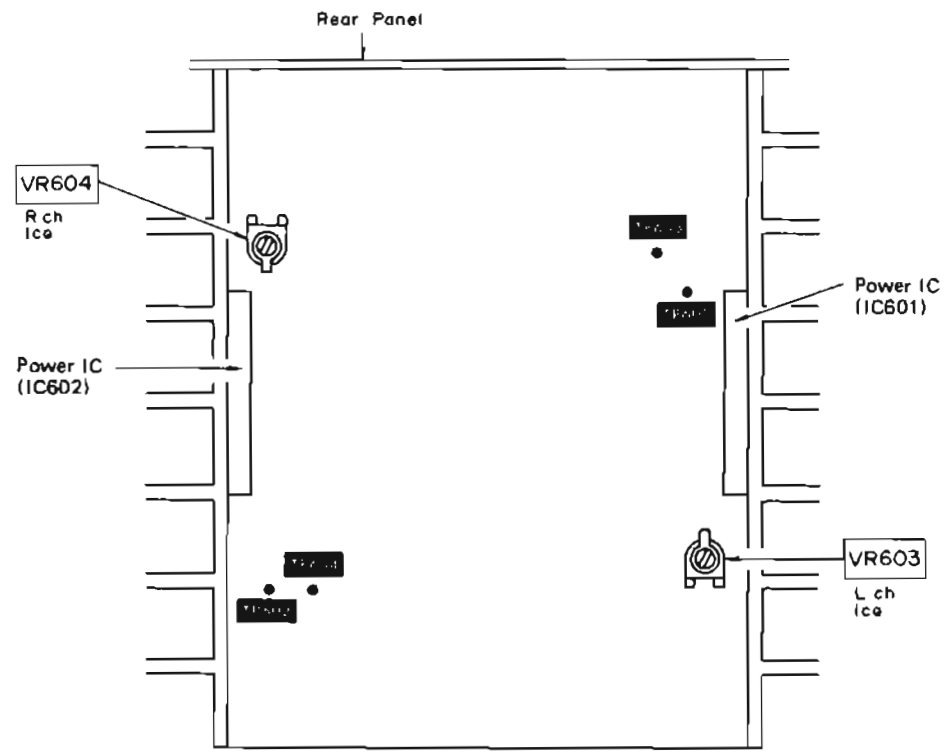

ADJUSTING INSTRUCTIONS

ENGLISH

AMPLIFIER ADJUSTMENT

● Setting of controls and instruments to be used

1. Speaker switch . . . . . Main
2. Sound volume . . . . . 0 (minimum)
3. DC voltmeter (capable to measure 5mV)

\* Before the adjustment, VR603 and VR604 should be turned to counter-clockwise direction.

No.	ADJUSTMENTS	DC VOLTMETER CONNECTION	PARTS ADJUSTED	ADJUSTING PROCEDURE
1	Ica	(L channel) Between TP601 and TP603 (minus probe) (R channel) Between TP602 and TP604 (minus probe)	VR603 (L channel) VR604 (R channel)	* Adjust VR603 (L ch) and VR604 (R ch) to approx. 6mV after ten minutes warm-up time.

- \* Set FM/AM allocation selector to "FM 0.2MHz/AM 10kHz" position.
- \* Set antenna selector to "normal" position.

AM TUNER ADJUSTMENT

● Setting and Equipment used

1. AC and DC electronic voltmeters (VTVM)
2. AM signal generator (AM-SG)
3. Maintain line voltage at rated voltage.
4. Output of signal generator should be no higher than necessary to obtain an output reading.
5. Adjust the antenna coil (L201) position by using a screwdriver so that it is at approximately 7cm degrees to the rear panel.
6. Set input selector to "tuner" position.
7. Use a non-metal screwdriver for the adjustment.
8. Set FM muting/mode switch to "off/FM mono" position.
9. Set broadcast selector to "AM" position.
10. Set speaker selector to "main" position.

Step No.	AM SIGNAL GENERATOR		DISPLAY FREQUENCY	PREPARATIONS	PARTS ADJUSTED	ADJUSTING PROCEDURE
	CONNECTION	FREQUENCY				
<b>AM-IF ADJUSTMENT</b>						
1	Connect AM-SG to AM antenna terminal through 200pF capacitor. Common to chassis. (Powerful input)	450kHz (30% Mod with 400Hz)	Frequency of non-interference	Connect AC VTVM or scope to "Speaker" terminals of the set.	T201 (1st IFT) T202 (2nd IFT)	* Adjust the input frequency and adjustment points so that the output becomes maximum.
<b>AM-RF ADJUSTMENT</b>						
2	Connect AM-SG to AM antenna terminal through 200pF capacitor. Common to chassis. (Weak input)	530kHz (30% Mod. with 400Hz)	530kHz	Connect DC VTVM to  terminal.	L202 (OSC Coil)	Adjust L202 to 1.1V ± 0.05V.
3		610kHz (30% Mod with 400Hz)	610kHz	Connect AC VTVM to scope to "Speaker" terminals of the set.	L201 (ANT Coil)	1. Adjust for maximum output. 2. Adjust ferrite core of L201 by screwdriver.
4		1500kHz (30% Mod. with 400Hz)	1500kHz	Connect AC VTVM to scope to "Speaker" terminals of the set.	CT201 (ANT Trimmer)	1. Adjust for maximum output. 2. Repeat steps (3) and (4) until the frequency correctly matches the dial display.

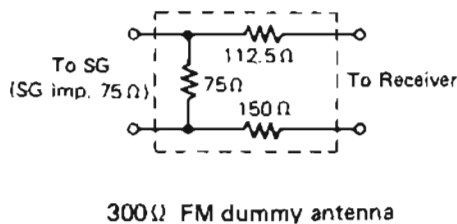

Fig. 9 (Abb. 9)

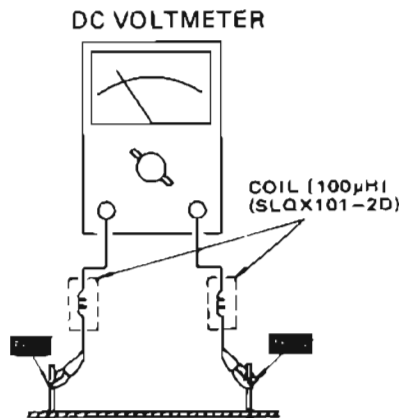

Fig. 10 (Abb. 10)

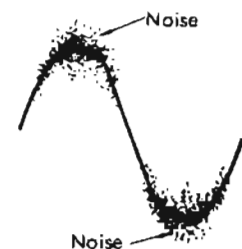

Fig. 11 (Abb. 11)

## FM TUNER ADJUSTMENT

## • Equipment used

1. FM signal generator (FM-SG)
2. Stereo modulator
3. Distortion analyser
4. Oscilloscope
5. AC and DC electronic voltmeters (VTVM).
6. Frequency counter (19kHz and 108MHz measurable).
7. FM 300Ω dummy antenna (Fig. 9).

## • Preparation of FM signal generator (FM-SG)

1. Connect stereo modulator to FM-SG.
2. Apply SG output to antenna terminal of the set through 300Ω FM dummy antenna.
3. The standard input of the set is 60dB (1mV), 400Hz 100% modulation (Because of using dummy antenna, SG output must be 12dB plus (IHF). That is, when input is 60dB, SG output is to be 72dB).

## • Setting

1. Set IF band selector to "normal" position.
2. Set broadcast selector to "FM" position.
3. Other setting are the same as in AM adjustment.

Step No.	FM SIGNAL GENERATOR		DISPLAY FREQUENCY	INDICATOR	ADJUSTMENT POINTS	REMARKS
	CONNECTION	FREQUENCY				
<b>FM-IF ADJUSTMENT</b>						
5	—	No-Signal	Frequency of non-interference	Connect DC VTVM between <b>TP101</b> and <b>TP102</b> through choke coil. (Refer to Fig. 10)	T101 (Discr. IFT)	Adjust T101 core so that voltage measured in signal mode is 0V in 300mV range.
<b>FM RF ADJUSTMENT</b>						
6	—	No-Signal	87.9MHz	Connect DC VTVM to <b>②6</b> terminal.	L2 (OSC Coil)	Adjust L2 (OSC Coil) to 4.0V.
7	Connect FM-SG to FM antenna terminal through 300Ω FM dummy antenna.	90.1MHz (100% Mod. with 400Hz) weak input	90.1MHz	Connect scope to "Speaker" terminals of the set.	L3 (RF DET Coil 1st) L4 (RF DET Coil, 2nd) L1 (ANT Coil) T1 (FM IFT)	<ol style="list-style-type: none"> <li>1. Add weak input so that noise is included in the output wave form.</li> <li>2. Make the adjustment so that the output wave form is vertically symmetrical. (Refer to Fig. 11.)</li> <li>3. Repeat the steps (7) and (8) until the frequency correctly matches the broadcasts frequency display.</li> </ol>
8		106.1MHz (100% Mod. with 400Hz)	106.1MHz	Connect scope to "Speaker" terminals of the set.	CT1 (OSC Trimmer)	
<b>FM MONO DISTORTION ADJUSTMENT</b>						
9	Connect FM-SG to FM antenna terminal through 300Ω FM dummy antenna. (Apply 60dB to antenna terminal)	100.1MHz (100% Mod. with 400Hz)	100.1MHz	Connect distortion analyser to "Speaker" terminals of the set.	T101, T102 (Discr. IFT)	<ol style="list-style-type: none"> <li>1. Set the FM muting/FM mode switch to "on/auto" and then check step (5) in no signal mode.</li> <li>2. If it is deflected, readjust of T101.</li> <li>3. Adjust T102 core so that distortion of right and left channels are minimized.</li> </ol>
<b>FM MUTING LEVEL ADJUSTMENT</b>						
10	Connect FM-SG to FM antenna terminal through 300Ω FM dummy antenna. (Apply 12dB [product for (XA) only 10dB] to antenna terminal)	100.1MHz (100% Mod. with 400Hz)	100.1MHz	Connect AC VTVM or scope to "Speaker" terminals of the set.	VR101 (Muting level)	<ol style="list-style-type: none"> <li>1. Set the FM muting/FM mode switch to "off/mono".</li> <li>2. With the FM muting/FM mode switch set to "on/auto", adjust VR101 so that the output is given with muting condition released.</li> </ol>
<b>SIGNAL METER LED (Light Emitting diode) INDICATOR ADJUSTMENT</b>						
11	Connect FM-SG to FM antenna terminal through 300Ω FM dummy antenna. (Apply 45dB to antenna terminal)	100.1MHz (100% Mod. with 400Hz)	100.1MHz	Signal meter LED	VR102 (Meter level)	Adjust VR102 while observing the signal meter LED so that the indicator at 5th is about to turn on.
<b>FM MPX PILOT (VCO) ADJUSTMENT</b>						
12	Connect FM-SG to FM antenna terminal through 300Ω FM dummy antenna. (Monaural signal)	100.1MHz (Non-modulated)	100.1MHz	Connect frequency counter to <b>TP301</b> terminal.	VR301 (VCO)	<ol style="list-style-type: none"> <li>1. Set the FM muting/FM mode switch to "on/auto".</li> <li>2. Adjust VR301 to 19kHz ± 30Hz.</li> </ol>

Step No.	FM SIGNAL GENERATOR		DISPLAY FREQUENCY	INDICATOR	ADJUSTMENT POINTS	REMARKS
	CONNECTION	FREQUENCY				
<b>SEPARATION ADJUSTMENT (Normal IF band)</b>						
13	Connect FM-SG to FM antenna terminal through 300Ω FM dummy antenna. (Pilot 10% Mod. stereo signal)	100.1MHz (100% Mod. with 1kHz) (L or R mode)	100.1MHz	Connect AC VTVM to "Speaker" terminals of the set.	VR302 (Normal IF separation)	<ol style="list-style-type: none"> <li>1. Set the IF band selector to "normal".</li> <li>2. Set the FM muting/FM mode switch to "on/auto".</li> <li>3. Adjust VR301 so that R output is minimized when stereo modulator is in L (L ch. modulation) mode and that L output is minimized in R mode.</li> </ol>
<b>SEPARATION ADJUSTMENT (Narrow IF band)</b>						
14	Connect FM-SG to FM antenna terminal through 300Ω FM dummy antenna. (Pilot 10% Mod. stereo signal)	100.1MHz (100% Mod. with 1kHz) (L or R mode)	100.1MHz	Connect AC VTVM to "Speaker" terminals of the set.	VR303 (Narrow IF separation)	<ol style="list-style-type: none"> <li>1. Set the IF band selector to "narrow".</li> <li>2. Set the FM muting/FM mode switch to "on/auto".</li> <li>3. Adjust VR303 so that R output is minimized when stereo modulator is in L (L ch. modulation) mode and that L output is minimized in R mode.</li> </ol>

## EINSTELLUNGSANWEISUNGEN ————— DEUTSCH

### ICQ-EINSTELLUNG

- Vor der Abstimmung VR603 und VR604 bis zum Anschlag entgegen dem Uhrzeigersinn drehen.
- Einstellung der zu benutzenden Regler und Instrumente
  1. Lautsprecherschalter ..... Hauptlautsprecher (main).
  2. Lautstärke ..... "0" (Minimalstellung).
  3. Gleichstromvoltmeter ..... 5mV Meßbereich erforderlich.

Nr.	Einstellungen	Gleichstromvoltmeter-verbindungen	Einstellungspunkte	Einstellungsvorgang
1	ICQ	L-Kanal. Zwischen TP601 und TP603 (Minustest) R-Kanal. Zwischen TP602 und TP604 (Minustest)	VR603 (L-Kanal) VR604 (R-Kanal)	*VR603 (L-Kanal) und VR604 (R-Kanal) auf ungefähr 6mV, nach 10 Minuten Anwärmezeit, einstellen.

- FM/AM Wellenverteilungs-Wahlschalter auf Position "FM 0.2MHz/AM 10kHz" stellen.

### AM (MW)-EINSTELLUNG

- **Stellungen und zu benutzende Geräte**
  1. Elektronische Voltmeter für Wechsel- und Gleichstrom (VTVM) Winkel von ca. 7cm macht.
  2. AM (MW)-Meßsender (AM-SG)
  3. Netzspannung auf ihren Sollwert halten.
  4. Der Ausgang des Meßsenders darf nicht höher sein als unbedingt notwendig für eine gute Ablesung.
  5. Mittels eines Schraubenziehers die Stellung der Antennenspule (L201) so einstellen, daß, sie gegen die Rückenplatte einen
  6. Den Eingangswähler auf die "tuner"-Position stellen.
  7. Einen nichtmetallischen Schraubenzieher für die Einstellungen verwenden.
  8. FM Muting/Mode Schalter ... off/mono
  9. Bereichsschalter ... AM
  10. Lautsprecherschalter ... main

Nr.	AM (MW)-MESSENDER		ANZEIGE-FREQUENZ DURCH VOR-EINSTELLUNG	VORBEREITUNG	ABGLEICHSPUNKTE	ABGLEICHsverfahren
	ANSCHLUSS	FREQUENZ				
<b>AM(MW)-ZF-ABGLEICH</b>						
1	Einen MW-Signal-generator über einen 200pF Kondensator mit dem MW-Antenneneingang verbinden. Die gemeinsame Leitung mit dem Chassis verbinden. (Starker Eingang)	450kHz (400Hz Modul., 30%)	Kein Empfang	Oszilloskop oder Wechselstrom-Voltmeter über den Lautsprecher schließen.	T201 (1. IFT) T202 (2. IFT)	Die Eingangsfrequenz und die Einstellungspunkte so adjustieren, daß der Ausgang den maximalen Wert erreicht.

AM (MW)-MESSENDER		ANZEIGE FREQUENZ DURCH VOR-EINSTELLUNG	VORBEREITUNG	ABGLEICHSPUNKTE	ABGLEICHsverFAHREN	
ANSCHLUSS	FREQUENZ					
<b>AM(MW)-HF-ABGLEICH</b>						
2	Einen MW-Signal-generator über einen 200pF Kondensator mit dem MW-Antenneneingang verbinden. Die gemeinsame Leitung mit dem Chassis verbinden. (Schwacher Eingang)	530kHz (400Hz Modulat., 30%)	530kHz	Zwischen  und Erdung Gleichstrom-Voltmeter schließen.	L 202 (Osc. Spule)	L 202 so justieren, daß die vom Gleichstrom-Voltmeter gemessene. (1.1V±0.05V)
3		610kHz (400Hz Modulat., 30%)	610kHz	Oszilloskop oder Wechselstrom-Voltmeter über den Lautsprecher schließen.	L 201 (Ant. Spule)	1. Auf max. Ausgang abgleichen. 2. Den Ferritkern von L 201 mit einem Schraubendreher justieren.
4		1500kHz (400Hz Modulat., 30%)	1500kHz	Oszilloskop oder Wechselstrom-Voltmeter über den Lautsprecher schließen.	CT 201 (Ant. Trimmer)	1. Auf max. Ausgang abgleichen. 2. Die Schritte (3) und (4) wiederholen, bis die Frequenz genau mit der Skalanzeige übereinstimmt.

**FM (UKW)-EINSTELLUNG**

- **Verwendete Einrichtungen**
  1. UKW-Meßsender (FM-SG)
  2. Stereo-Modulator (oder Trennmesser)
  3. Verzerrungsmesser
  4. Oszilloskop
  5. Elektronische Voltmeter für Wechsel- und Gleichstrom (VTVM)
  6. Signalfrequenzmesser (meßbar für 19kHz und 108MHz)
  7. UKW 300-Ohm Kunstantenne (Abb. 9)
- **Zustand des Gerätes**
  1. Den UKW-Antennenwahlschalter auf die "normal"-Stellung bringen.
- **Vorbereitung AM UKW-Messender (FM-SG)**
  1. Stereo-Modulator an FM-SG anschließen.
  2. SG-Ausgang über 300-Ohm UKW Kunstantenne an den Antenneneingang des Gerätes schließen.
  3. Der normale Eingang des Gerätes beträgt 60dB (1mV), 400Hz 100% Modulation. (Wegen Verwendung der Kunstantenne muß der Signalausgang 12dB plus (IHF) sein. d.h. beim Eingang von 60dB soll der Signalausgang 72dB sein.)
- 2. Den Eingangswähler auf die "FM"-Position stellen.
  3. Die anderen Einstellungen entsprechen den AM (MW)-Einstellungen.

FM (UKW) MESSENDER		ANZEIGE-FREQUENZ DURCH VOR-EINSTELLUNG	VORBEREITUNG	ABGLEICHSPUNKTE	ABGLEICHsverFAHREN	
ANSCHLUSS	FREQUENZ					
<b>UKW-ZF-ABGLEICH</b>						
5	-	Kein Signal	Kein Empfang	Ein Gleichstromröhren-voltmeter zwischen TP101 und TP102 über eine Drosselspule verbinden. (Siehe Abb. 10)	T 101 (Diskriminator FT)	Den Kern von T101 so justieren, daß die gemessene Spannung im signallosen Modus 0V im 300mV Bereich beträgt.
<b>UKW-HF-ABGLEICH</b>						
6	-	Kein Signal	87,9MHz	Zwischen  und Erdung Gleichstrom-Voltmeter schließen.	L 2 (Osc. Spule)	L 2 so justieren, daß die vom Gleichstrom-Voltmeter gemessene Spannung 4.0V beträgt.
7	Meßsender über eine Kunstantenne an den UKW-Antenneneingang schließen.	90.1MHz (400Hz Modulat., 100%)	90.1MHz	Oszilloskop über den Lautsprecher schließen.	L 3 (HF Det. Spule 1) L 4 (HF Det. Spule 2) L 1 (Ant. Spule)	1. Einen schwachen Eingang geben, bei dem Geräusch in der Ausgangswellenform enthalten wird. 2. So einstellen, daß die Ausgangswellenform vertikal symmetrisch wird. (Abb. 11) 3. Die Einstellung von (7) und (8) wiederholen, bis die Frequenz mit der Skala übereinstimmt.
8		106.1MHz (400Hz Modulat., 100%)	106.1MHz	Oszilloskop über den Lautsprecher schließen.	CT 1 (Osc. Trimmer)	
<b>ABGLEICH AUF MIN. VERZERRUNG IN STELLUNG UKW-MONO</b>						
9	Meßsender über eine Kunstantenne an den UKW-Antenneneingang schließen	100.1MHz (400Hz Modulat., 100%)	100.1MHz	Klirrfaktor-Meßbrücke über den Lautsprecher schließen.	T 101, T 102 (Diskriminator FT)	1. Den UKW Muting/UKW-Betriebsartschalter auf "on/ auto" einstellen und dann Schritt (5) im signallosen Zustand prüfen. 2. Wenn Abweichung vorliegt (primäre Seite) von T 101 wieder einstellen. 3. T 102 Kern für minimale Verzerrung der rechten und linken Kanäle justieren.

FM (UKW) MESSENDER		ANZEIGE FREQUENZ DURCH VOR-EINSTELLUNG	VORBEREITUNG	ABGLEICHSPUNKTE	ABGLEICHsverFAHREN	
ANSCHLUSS	FREQUENZ					
<b>UKW-STUMMABSTIMMUNGS PEGELANZEIGER</b>						
10	Meßsender über eine Kunstantenne an den UKW-Antenneneingang schließen. (12dB in den Antenneneingang leiten.)	100.1MHz (400Hz Modulat., 100%)	100.1MHz	Oszilloskop oder Wechselstrom-Voltmeter über den Lautsprecher schließen.	VR101 (UKW-Muting)	1. Den UKW Muting/UKW-Betriebsartschalter auf "off/mono" einstellen. 2. "Muting" Schalter auf "on" stellen. VR101 so einstellen, daß der Ausgang unter Bewirken der Dämpfung gegeben wird.
<b>ABGLEICHEN DES SIGNALMETER-LED (LICHTERZEUGENDE DIODE) – ANZEIGERS</b>						
11	Meßsender über eine Kunstantenne an den UKW-Antenneneingang schließen. Meßsender auf 45dB einstellen.	100.1MHz (400Hz Modulat., 100%)	100.1MHz	Signalmeter-LED	VR102 (Metervolumen)	Unter Beobachtung der Signalmeter-LED VR201 so justieren, daß der Anzeiger am 5. fast aufzuleuchten beginnt.
<b>UKW-MPX-PILOTABGLEICH (VCO)</b>						
12	Meßsender über eine Kunstantenne an den UKW-Antenneneingang schließen. (Mono-Signal)	100.1MHz (Unmodulierte Welle)	100.1MHz	Signal frequenzmesser an <b>TP301</b> schließen.	VR301 (VCO)	1. Den UKW Muting/UKW-Betriebsartschalter auf "on/auto" einstellen. 2. VR301 so abgleichen, daß Ausgangsfrequenz von <b>TP301</b> 19kHz ± 30Hz
<b>TRENNUNG-ABGLEICH (Normal IF band)</b>						
13	Meßsender über eine Kunstantenne an den UKW-Antenneneingang schließen. (Stereo-Pilotsignal 10% moduliert.)	100.1MHz (400Hz Modulat., 100%) L- oder R-Betriebsart)	100.1MHz	Wechselstrom-Voltmeter über den Lautsprecher schließen.	VR302 (Normal IF Separation)	1. FM-ZF-Bandbreitenschalter ... normal 2. Den UKW Muting/UKW-Betriebsartschalter auf "on/auto" einstellen. 3. VR302 auf minimale Anzeige des R-Ausgangs bei Stereomodulator in L-(L-Kanalmodulation) Modus, und auf minimale Anzeige des L-Ausgangs in R-Modus abgleichen.
<b>TRENNUNG-ABGLEICH (Narrow IF band)</b>						
14	Meßsender über eine Kunstantenne an den UKW-Antenneneingang schließen. (Stereo-Pilotsignal 10% moduliert.)	100.1MHz (400Hz Modulat., 100%) L- oder R-Betriebsart)	100.1MHz	Wechselstrom-Voltmeter über den Lautsprecher schließen.	VR303 (Narrow IF Separation)	1. FM-ZF-Bandbreitenschalter ... narrow 2. Den UKW Muting/UKW-Betriebsartschalter auf "on/auto" einstellen. 3. VR302 auf minimale Anzeige des R-Ausgangs bei Stereomodulator in L-(L-Kanalmodulation) Modus, und auf minimale Anzeige des L-Ausgangs in R-Modus abgleichen.

**INSTRUCTIONS DE REGLAGE — FRANÇAIS**

**REGLAGE DE ICQ**

- Avant la mise au point, VR603 et VR604 devront être tournés dans la direction ou inverse des aiguilles d'une montre.
- Réglage des commandes et instruments à utiliser
  1. Commutateur du haut-parleur ..... Principal
  2. Volume du son ..... 0 (minimum)
  3. Voltmètre CC (pouvant mesurer 5mV)

No.	Reglages	Connexions du voltmètre CC	Point de réglage	Procédé de réglage
1	ICQ	Canal G. Entre <b>TP601</b> et <b>TP603</b> (sonde au moins) Canal D. Entre <b>TP602</b> et <b>TP604</b> (sonde au moins)	VR603 (Canal G) VR604 (canal D)	Régle les VR603 (canal gauche) et VR604 (canal droit) sur env. 6mV après 10mn de préchauffage.

- Régler le sélecteur d'attribution FM/AM sur la position "FM 0,2MHz/AM 10kHz".

## REGLAGE DE AM

● **Réglage et équipement utilisé**

- |   |   |
|---|---|
| <ol style="list-style-type: none"> <li>1. Voltmètres électronique de courant alternatif et de courant continu (VTVM)</li> <li>2. Générateur du signal AM (AM-SG)</li> <li>3. Conserver la tension du secteur à la tension nominale.</li> <li>4. Le signal du générateur ne doit pas être plus élevé qu'il n'est nécessaire à obtenir une lecture en sortie.</li> <li>5. Régler la position de la bobine (L201) de l'antenne en utilisant</li> </ol> | <ol style="list-style-type: none"> <li>6. un tournevis de telle sorte qu'elle soit environ à 7cm de la plaque arrière.</li> <li>7. Sélecteur d'entrée sur la position "tuner"</li> <li>8. Utiliser un tournevis non-métallique pour le réglage.</li> <li>9. Commutateur de silencieux/mode ... off/mono</li> <li>10. Sélecteur de gamme ... AM</li> <li>11. Commutateur du haut-parleur ... principal.</li> </ol> |
|---|---|

AM GENERATEUR		FREQUENCE D'AFFICHAGE PAR PREREGLAGE	PREPARATIONS	ELEMENTS REGLES	PROCEDURE DE REGLAGE
BRANCHEMENT	FREQUENCE				

## REGLAGE DE FI-AM

No.	BRANCHEMENT	FREQUENCE	PREPARATIONS	ELEMENTS REGLES	PROCEDURE DE REGLAGE	
1	Brancher le AM-SG à la borne de l'antenne AM par un condensateur de 200pF. Commun au châssis. (Entrée sous puissante)	450kHz (modulé à 30% par 400Hz)	Point sans signal	Brancher un c.a. voltmètre électronique ou un oscilloscope sur les bornes de haut-parleur de l'ampli-tuner.	T201 (1 transfo F1) T202 (2 transfo F1)	Régler la fréquence d'entrée et les points de réglage de telle sorte que la sortie devienne maximale.

## REGLAGE DE RF-AM

No.	BRANCHEMENT	FREQUENCE	PREPARATIONS	ELEMENTS REGLES	PROCEDURE DE REGLAGE	
2		530kHz (modulé à 30% par 400Hz)	530kHz	Brancher le voltmètre à courant continu entre 23 et la prise de terre.	L202 (Bobine OSC)	Régler L202 de telle sorte que le voltage mesuré par le voltmètre à courant continu, soit de 1.1V ± 0.05V.
3	Brancher le AM-SG à la borne de l'antenne AM par un condensateur de 200pF. Commun au châssis. (Entrée faible)	610kHz (modulé à 30% par 400Hz)	610kHz	Brancher un c.a. voltmètre électronique ou un oscilloscope sur les bornes de haut-parleur de l'ampli-tuner.	L201 (Bobine Ant.)	1. Régler au maximum de signal de sortie. 2. Régler le noyau ferrite de L201 à l'aide d'un tournevis.
4		1500kHz (modulé à 30% par 400Hz)	1500kHz	Brancher un c.a. voltmètre électronique ou un oscilloscope sur les bornes de haut-parleur de l'ampli-tuner.	CT201 (Trimmer Ant.)	1. Régler au maximum de signal de sortie. 2. Refaire les étapes (3) et (4) jusqu'à ce que la fréquence s'aligne correctement avec l'affichage du cadran.

## REGLAGE DE FM

● **Équipement utilisé**

1. Générateur du signal FM (FM-SG)
2. Commande de réglage stéréophonique (ou vu-mètre de séparation).
3. Jauge de distorsion.
4. Oscilloscope.
5. Voltmètres électronique de courant alternatif et de courant continu (VTVM).
6. Compteur de fréquence (19kHz et 108MHz mesurable).
7. Antenne fictive FM, 300 ohms (Fig. 9)

● **Conditions de l'appareil**

1. Placer le sélecteur de l'antenne FM sur la position "normal".
2. Sélecteur d'entrée sur la position "FM".

● **Préparation du générateur de signal FM (FM-SG)**

1. Brancher la commande de réglage stéréophonique à FM-SG.
2. Alimenter la sortie SG à la borne de l'antenne de l'appareil, par l'antenne fictive FM, 300 ohms.
3. L'entrée standard de l'appareil est de 60dB (1mV), 400Hz, 100% de modulation (à cause de l'utilisation de l'antenne fictive, la sortie SG doit être de plus 12dB (IHF). Ce qui signifie que quand l'entrée est de 60dB, la sortie SG doit être de 72dB.)

3. Les autres réglages sont les mêmes que les réglages de AM.

FM GENERATEUR		FREQUENCE D'AFFICHAGE PAR PREREGLAGE	PREPARATIONS	ELEMENTS REGLES	PROCEDURE DE REGLAGE
BRANCHEMENT	FREQUENCE				

## REGLAGE DE FI-FM

No.	BRANCHEMENT	FREQUENCE	PREPARATIONS	ELEMENTS REGLES	PROCEDURE DE REGLAGE	
5	—	Sans Signal	Point sans signal	Brancher le voltmètre électronique a.c.c. aux bornes TP101 et TP102 (Voir la Fig. 10)	T101 (Transfo FI discri.)	Régler le noyau T101 de telle sorte que le voltage mesuré dans le mode sans signal, soit de 0V dans la gamme des 300mV.

## REGLAGE DE RF-FM

No.	BRANCHEMENT	FREQUENCE	PREPARATIONS	ELEMENTS REGLES	PROCEDURE DE REGLAGE	
6	—	Sans Signal	87.9MHz	Brancher le voltmètre à courant continu entre 20 et la prise de terre.	L2 (Bobin Osc.)	Régler L2 de telle sorte que le voltage mesuré par le voltmètre à courant continu soit de 4.0V.

FM GENERATEUR		FREQUENCE D'AFFICHAGE PAR PREREGLAGE	PREPARATIONS	ELEMENTS REGLES	PROCEDURE DE REGLAGE	
BRANCHEMENT	FREQUENCE					
7	Branchez sur la prise d'antenne FM à travers une antenne fictive FM	90.1MHz (modulé à 100% par 400Hz)	90.1MHz	Branchez un oscilloscope sur les bornes de haut-parleur de l'amplificateur.	L3 (1er détecteur) L4 (2e détecteur) L1 (Bobin Ant.)	<ol style="list-style-type: none"> <li>1. Appliquer une entrée faible de telle sorte que le parasite soit compris dans la forme de l'onde de sortie.</li> <li>2. Faire le réglage de telle sorte que la forme de l'onde de sortie soit verticalement symétrique. (Voir Fig. 11)</li> <li>3. Refaire les réglages (7) et (8) jusqu'à ce que la fréquence corresponde correctement avec l'échelle du cadran.</li> </ol>
		106.1MHz (modulé à 100% par 400Hz)	106.1MHz	Branchez un oscilloscope sur les bornes de haut-parleur de l'amplificateur.	CT1 (Trimmer Osc.)	
<b>REGLAGE DE LA DISTORSION FM EN MONO</b>						
9	Branchez sur la prise d'antenne FM à travers une antenne fictive FM.	100.1MHz (modulé à 100% par 400Hz)	100.1MHz	Branchez un distorsionmètre sur les bornes de haut-parleur de l'appareil.	T101, T102 (Transfo FI discri.)	<ol style="list-style-type: none"> <li>1. Placer le commutateur de réglage silencieux de FM/ mode de FM sur la position "on/auto" et vérifier l'étape (5) dans le mode sans signal.</li> <li>2. S'il est déplacé, re-régler (côté primaire) de T101.</li> <li>3. Régler le noyau T102 de telle sorte que la distorsion des canaux droit et gauche soit la plus faible.</li> </ol>
<b>REGLAGE DU SEUIL DU SILENCIEUX D'ACCORD</b>						
10	Branchez sur la prise d'antenne FM à travers une antenne fictive FM. (Appliquer 12dB à la borne de l'antenne.)	100.1MHz (modulé à 100% par 400Hz)	100.1MHz	Branchez un c.a. voltmètre électronique ou un oscilloscope sur les bornes de haut-parleur de l'amplificateur.	VR101	<ol style="list-style-type: none"> <li>1. Placer le commutateur de réglage silencieux de FM/ mode FM sur "off/mono".</li> <li>2. Avec le commutateur de mode/régulation silencieux "on/auto", régler le VR101 de telle sorte que la sortie fournie avec le réglage silencieux en position déclenchée.</li> </ol>
<b>ALIGNEMENT DE L'INDICATEUR DE SIGNAL DE LA DIODE A EMISSION DE LUMIERE (DEL)</b>						
11	Branchez sur la prise d'antenne FM à travers une antenne fictive FM. Niveau de sortie du générateur 45dB	100.1MHz (modulé à 100% par 400Hz)	100.1MHz	DEL du compteur à signal de l'aiguille du cadran.	VR102 (Registor variable du compteur)	Régler VR102 en observant la DEL du compteur à signal afin que l'indicateur au 5ème est à presque tourner.
<b>REGLAGE (VCO) PILOTE MULTIPLEX FM</b>						
12	Branchez sur la prise d'antenne FM à travers une antenne fictive FM. (Signal monostéré)	100.1MHz Non modulé	100.1MHz	Branchez le compteur de fréquence à TP301	VR301	<ol style="list-style-type: none"> <li>1. Placer le commutateur de réglage silencieux de FM/ mode FM sur "on/auto".</li> <li>2. Régler VR301 de telle sorte que la fréquence de sortie de TP301 soit de 19kHz ±30Hz.</li> </ol>
<b>REGLAGE DE LA SEPARATION DES CANAUX (Normal IF band)</b>						
13	Branchez sur la prise d'antenne FM à travers une antenne fictive FM. (Signal stéréo pilote à 10% de modulation)	100.1MHz (modulé à 100% par 400Hz) (Mode G ou D.)	100.1MHz	Branchez un oscilloscope sur les bornes de haut-parleur de l'amplificateur.	VR302 (Normal IF Separation)	<ol style="list-style-type: none"> <li>1. Interrupteur de gamme FM-IF ... normal.</li> <li>2. Placer le commutateur de réglage silencieux de FM/ mode FM sur "on/auto".</li> <li>3. Régler VR302 de telle sorte que la sortie droite soit minimale quand la commande d'accord stéréophonique est dans le mode gauche (modulation du canal gauche) et que la sortie gauche soit minimale dans le mode droit.</li> </ol>



FM GENERATEUR		FREQUENCE D'AFFICHAGE PAR PREREGLAGE	PREPARATIONS	ELEMENTS REGLES	PROCEDURE DE REGLAGE
BRANCHEMENT	FREQUENCE				
<b>REGLAGE DE LA SEPARATION DES CANAUX (Narrow IF band)</b>					
14 Branchez sur la prise d'antenne FM à travers une antenne fictive FM. (Signal stéréo pilote à 10% de modulation)	100.1MHz (modulé à 100% par 400Hz) (Mode G ou D.)	100.1MHz	Branchez un oscilloscope sur les bornes de haut-parleur de l'amplificateur.	VR303 (Narrow IF Separation)	<ol style="list-style-type: none"> <li>1. Interrupteur de gamme FM-IF ... narrow.</li> <li>2. Placer le commutateur de réglage silencieux de FM/ mode FM sur "on/auto".</li> <li>3. Régler VR303 de telle sorte que la sortie droite soit minimale quand la commande d'accord stéréophonique est dans le mode gauche (modulation du canal gauche) et que la sortie gauche soit minimale dans mode droit.</li> </ol>

## HOW TO REPLACE CHIPS

### (RESISTOR, CAPACITOR AND JUMPER)

1. Remove solder from chip by using solder sucker.
2. Remove chip with tweezers by rotating it while removing solder as shown in fig. 12.
3. Solder circuit board first and then solder chip in the direction of the arrow as shown in fig. 13.

**Notes:**

1. Do not use chip again which is removed from printed circuit board.
2. Use lead wire with insulator for replacement instead of chip jumper.

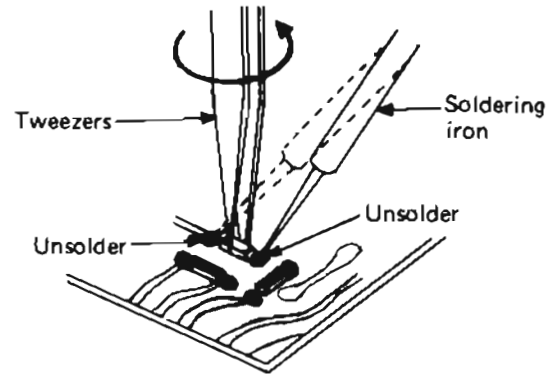

Fig. 12

Color	Original Parts Name
Black	Chip Resistor and Jumper
Brown, White or Green	Chip Capacitor

● **Note for replacing chips**

1. Do not heat chips more than three (3) seconds.
2. Be careful not to damage the electrode of chips.
3. Use soldering iron (less than 60W) and tweezers for replacing chips.

● **Precautions for repair**

When frequency is not indicated, FL (display tube), FL driver, digit circuit, and micro-computer must be checked by oscilloscope.  
In this case, take care not to allow shortcircuit between IC terminals or application of voltage from measuring instrument to IC terminals.

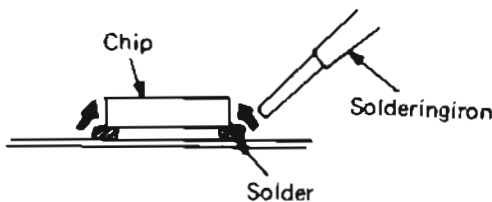
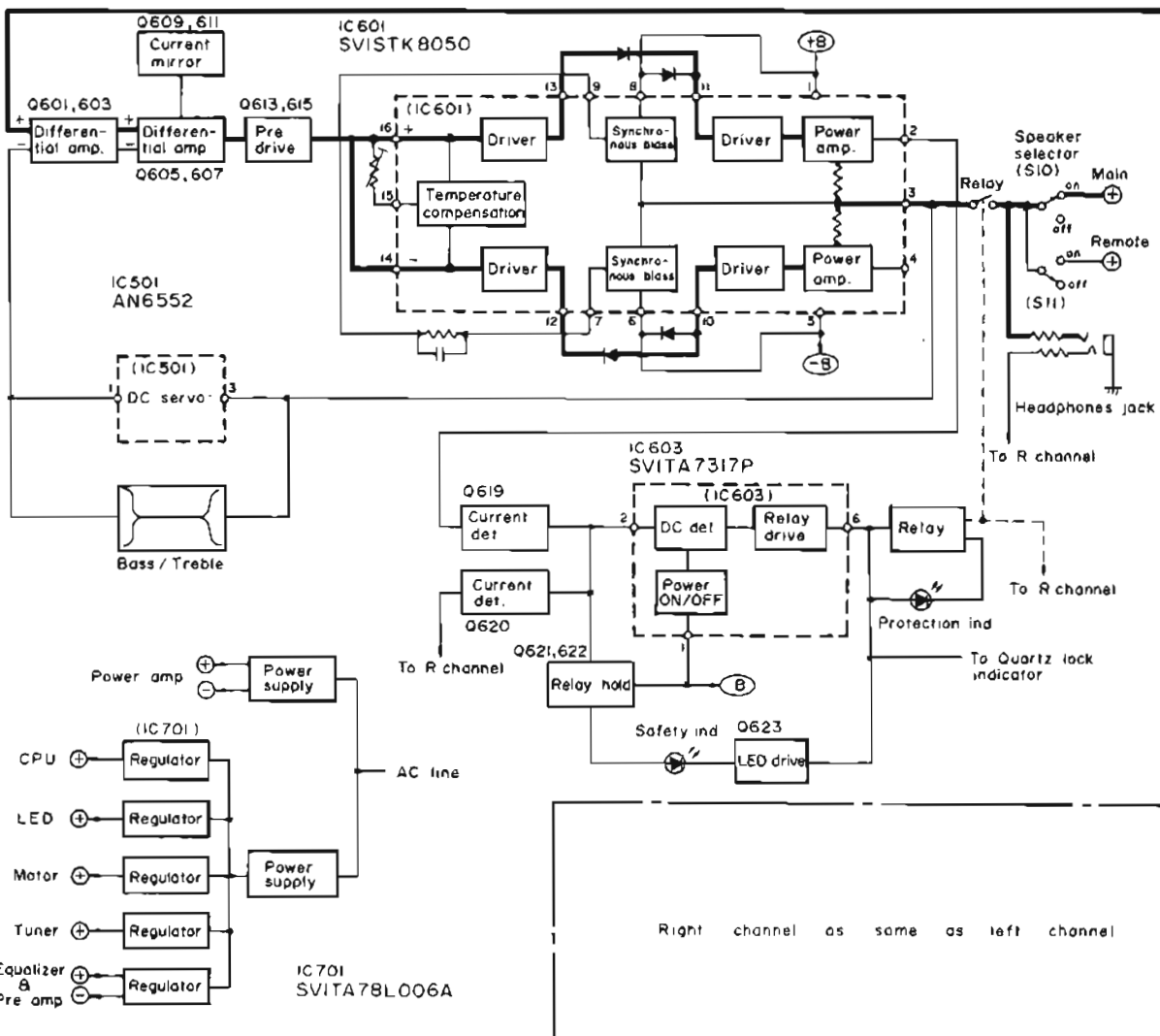
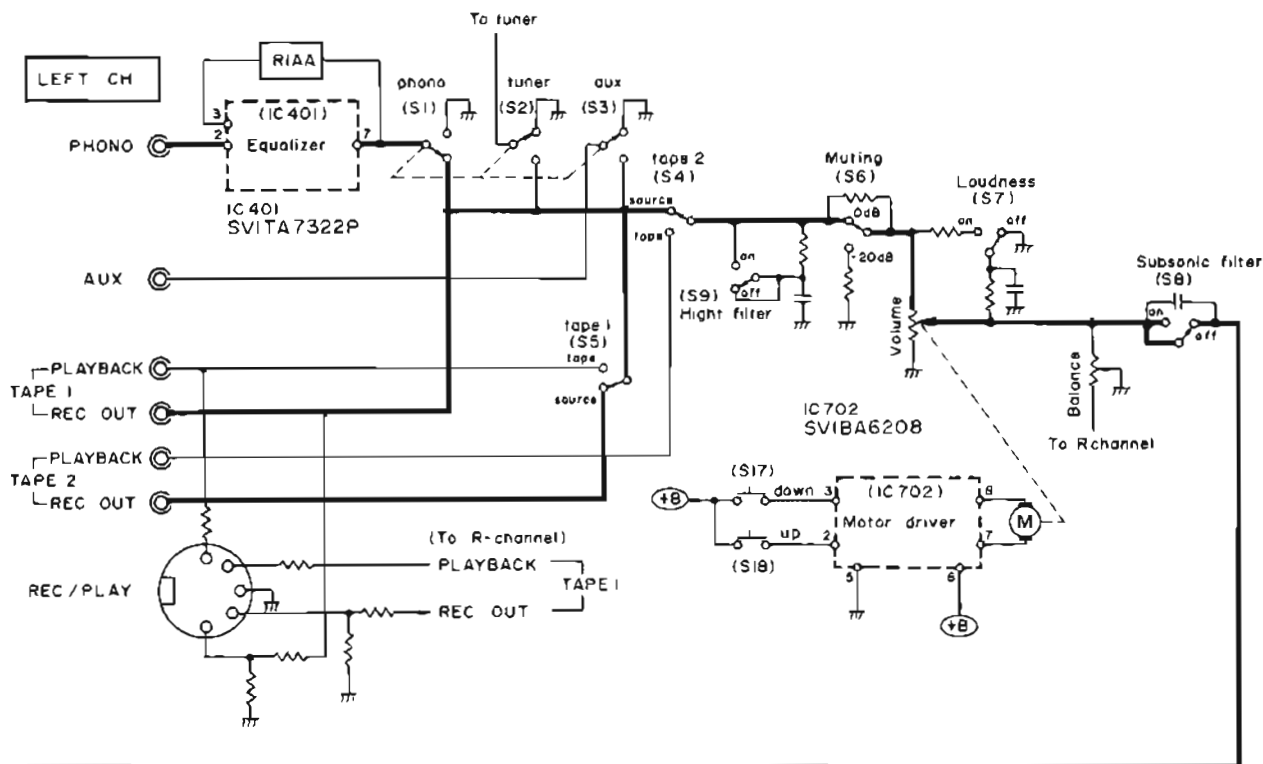
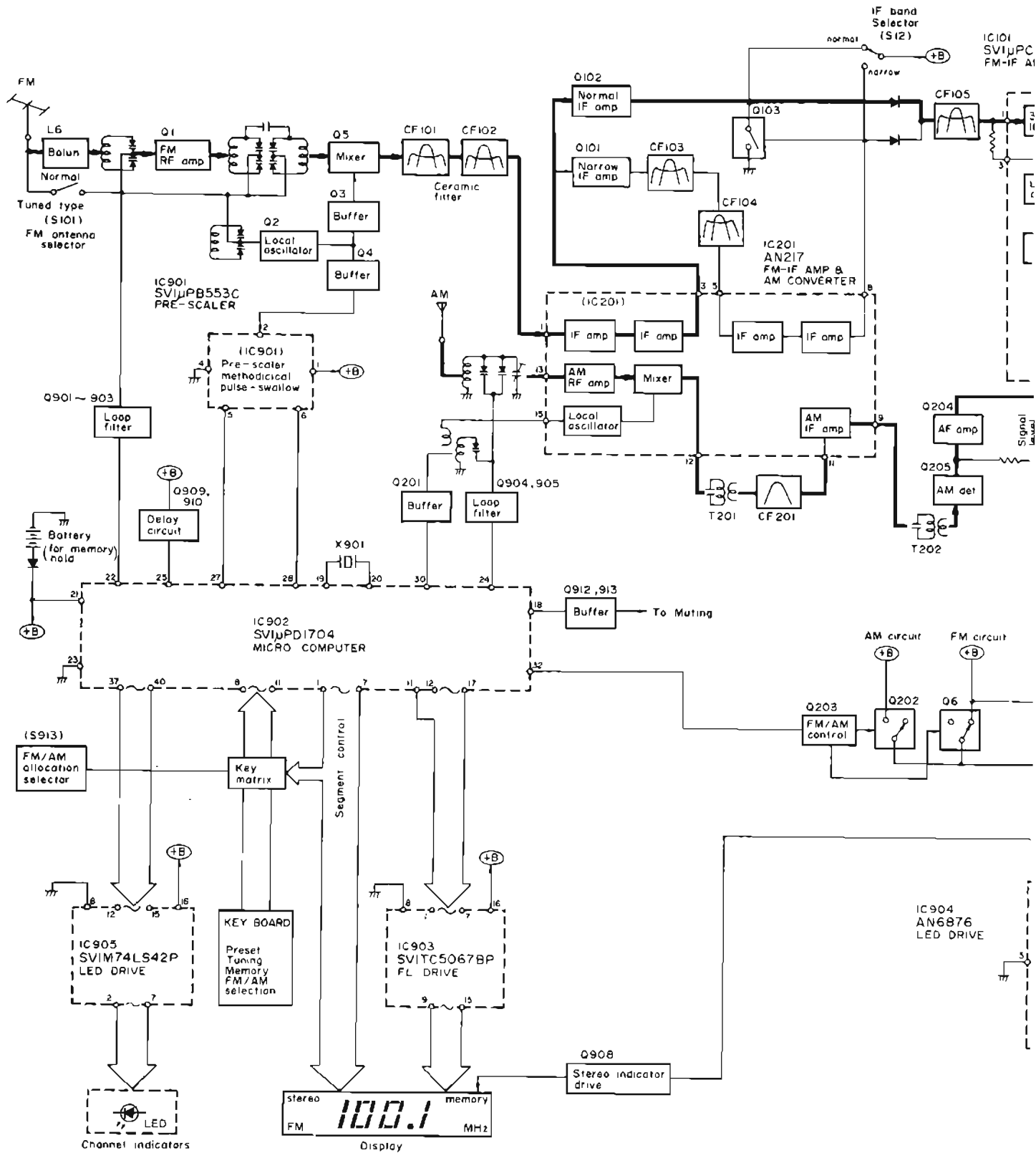

Fig. 13

■ BLOCK DIAGRAM (Amplifier and Tone control)



**BLOCK DIAGRAM (Tuner and Display)**





## ■ BLOCK DIAGRAM OF IC'S

This is the basic block diagram of the inside circuit of IC. In an actual circuit, there may be sometimes idle terminals or some different functions other than the basic circuit.

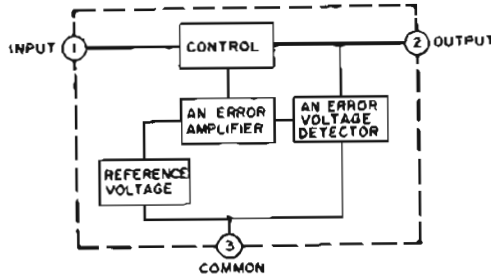

**IC701 (SVITA78L006A)**  
Voltage regulator

**IC401, 402 (SVITA7322P)**  
Equalizer amp.

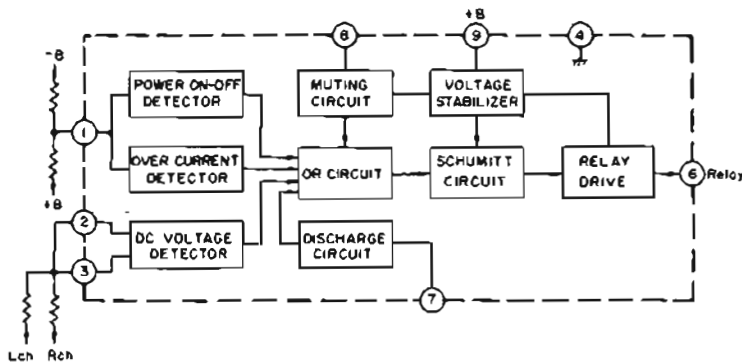
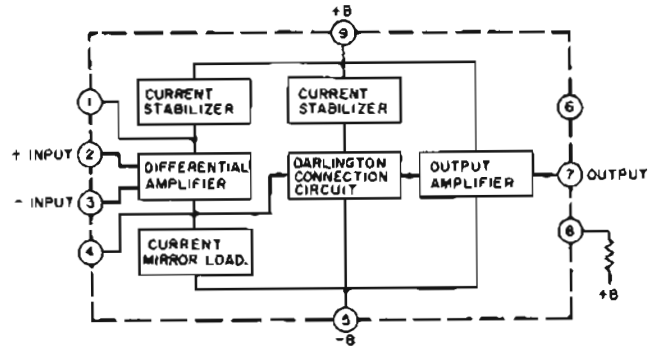

**IC603 (SVITA7317P)**  
Speakers protection

**IC301 (AN363N)**  
FM Multiplex

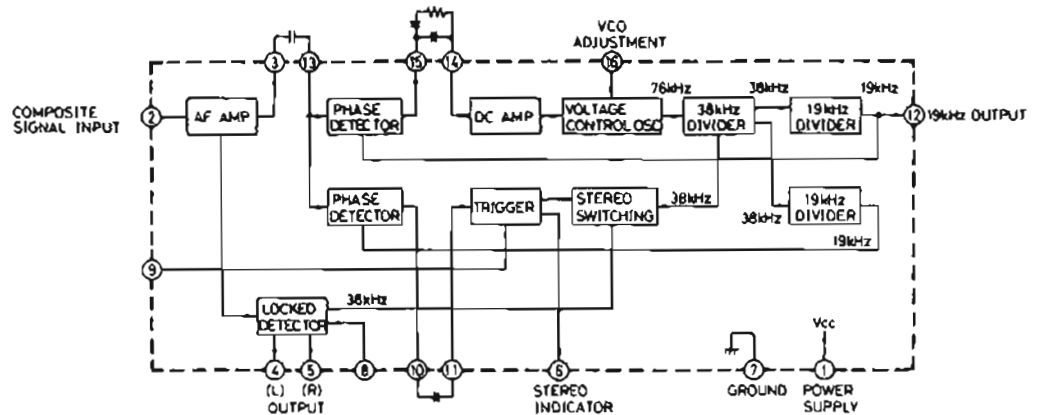

## VOLUME SWITCH (S17 and S18)

### ● 2-step tact switch

The switch (volume up/down switch) used in the motor volume circuit of this unit is a 2-step tact switch.

This switch has a common terminals and terminals 1, 2, 3 as shown in Fig. 14.

When the switch is lightly pressed, the common terminal is connected to terminals 1 and 3 (Fig. 15).

When the switch is strongly pressed, the common terminal is connected to terminals 1, 2 and 3 (Fig. 16).

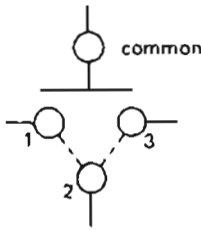

Fig. 14

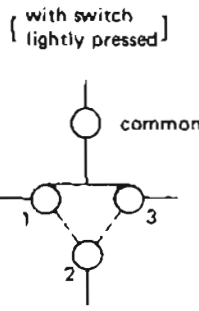

Fig. 15

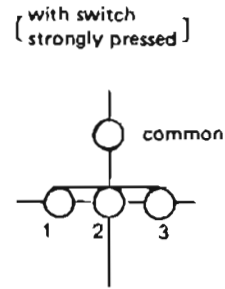

Fig. 16

## VARIABLE RESISTORS

### ● Alteration of resistance values according to the rotational angles of variable resistors

Alteration characteristics as shown below are often used for sets. All are intended to keep the frequency response of the set at optimum levels, and are used according to the types of circuits. For example, characteristic (B) is used for sound volume adjustment; (A) and (C) are for bass and treble sound quality adjustment; (G) is for medium sound quality adjustment; and (BH) is for the adjustment of sound balance between the right and left.

In the case of this unit, variable resistor with characteristic (C) which is short-circuited between its ends at rotational angle of  $150^\circ$  (center) is used for bass adjustment. Also, variable resistor with characteristic (C) whose resistance is zero at rotational angle of  $150^\circ$  (center) is used for treble adjustment. And characteristic (BH) in which two variable resistors are interlocked with characteristics (C) and (A) combined is used for the adjustment of sound level balance.

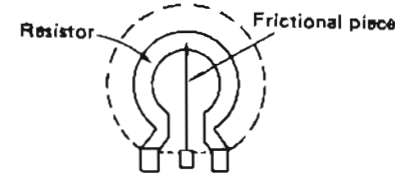
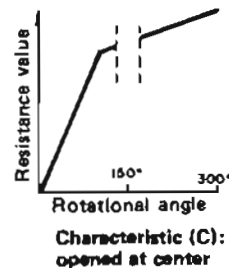
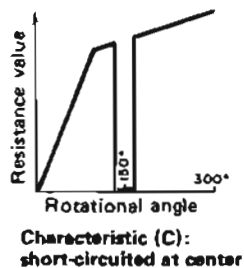
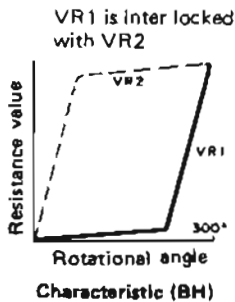
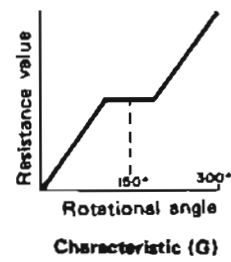
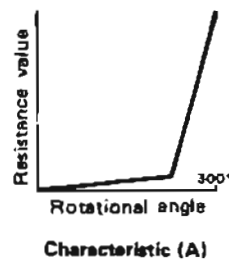
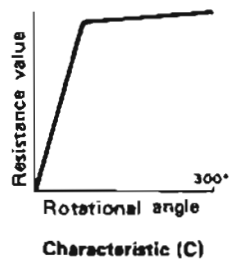
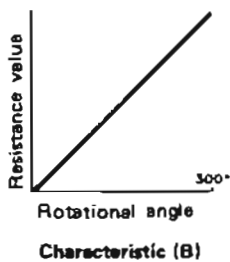

REPLACEMENT PARTS LIST ..... Electrical Parts

- Notes:** 1. Part numbers are indicated on most mechanical parts. Please use this part number of parts orders.  
 2. **▲** indicates that only parts specified by the manufacturer be used for safety.  
 3. Bracket indications in Ref. No. columns specify the area. Parts without these indications can be used for all areas.

- Areas**  
 • [E] and [EG] are available in Scandinavia and European.  
 • [XAL] is available in Australia.  
 • [XA] is available in Asia, Latin America, Middle East and Africa.  
 • [XGH] is available in Holland.  
 • [EB] is available in Belgium.

Ref. No.	Part No.	Part Name & Description
<b>INTEGRATED CIRCUIT</b>		
IC101 IC102 IC201 IC301 IC401, 402 IC501 IC601, 602  IC603 IC701 IC702 IC901 IC902 IC903 IC904 IC905	SVIUPC1167C2 AN6552F AN217P-BB AN363N SVITA7322P AN6552F SVI\$TK8050  SVITA7317P SVITA78L006A SVIBA6208 SVIUPB553C-E SVIUPD1704CL SVITC50678P AN6876 SVIM74LS42P	IC, FM IF Amp & EM Detector IC, Muting & Meter Amplifier IC, AM & FM IF Amplifier IC, FM Multiplex IC, Equalizer Amplifier IC, Tone Amplifier IC, Synchronous Bias Circuit and Power Amplifier IC, Speakers Protection IC, Regulator IC, Motor Driver IC, Pre-Scaler IC, Micro-Computer IC, FL Driver IC, LED Driver IC, Decoder
<b>TRANSISTORS</b>		
Q1 Q2~4 Q5 Q6, 202, 301, 302, 305, 910, 912, 914, 915 916 Q7, 103, 104, 105, 203, 204 906, 907, 909, 913 Q101, 102, 201 Q205, 918 Q303, 304 Q601~604  Q605~608  Q609~612  Q613, 614 Q615, 616, 711 Q617, 618  Q619, 620, 622, 623 Q621 Q701, 712  Q702 Q703 Q705, 708  Q706, 710 Q707 Q709 Q901~905 Q908	3SK74-L1 2SC2295 2SC2404 2SB709  2SD601  2SC2778 2SC1684-R 2SD601 2SC2320L-F  2SC2631-R  2SA666A1-R  2SA921-T 2SA1124-R 2SC2632-R  2SC1845  2SA992 2SA1015-Y  2SD880-Y 2SK34-D1 2SC1815-Y  2SC2632-R 2SD762-O 2SC1509-R 2SD601A 2SB709A	Transistor, FM RF Amplifier [FET] Transistor, FM Oscillator & Buffer (Chip) Transistor, FM Mixer (Chip) Transistor, Switching, AF Amplifier, Buffer & Driver (Chip)  Transistor, Switching & Driver (Chip)  Transistor, FM IF Amplifier & Buffer (Chip) Transistor, Switching (Use in ranks R or S) Transistor, Mute Switching (Chip) Transistor, Differential Amplifier (Use in ranks F or G) Transistor, Differential (Use in ranks R, S or T) Transistor, Current Mirror (Product Part No. 2SA964-Q or R) Transistor, Pre-Driver (Use in ranks Q, R or S) Transistor, Pre-Driver (Use in ranks R, S or T) Transistor, Constant Current (Use in ranks R, S or T) Transistor, Current Detector & LED Driver  Transistor, Relay Hold Transistor, Regulator (Use in ranks Y or O)  Transistor, Regulator Transistor, Current Stabilizer [FET] Transistor, Regulator & Switching (Use in ranks Y or O) Transistor, Regulator Transistor, Regulator (Use in ranks O or P) Transistor, Switching (Use in ranks Q, R or S) Transistor, Loop Filter (Chip) Transistor, Buffer (Chip)
<b>DIODES</b>		
D1~4 D101~105, 202~204, 206, 301, 603, 604, 616 D201 D205 D401~403 D404, 405 D601, 602 D605~612 D613, 614, 617 D615 D618 D619 D701~704 D705, 706, 709, 710, 713, 716, 718, 915 D707, 708	SVDBB204 MA162A  SVDBB113 2-0A90 LN224RP LN424YP MA162A 2-0A90 MA162A SVDSR1K2 LN417YP LN217RP SVDS3V40 SVDSR1K2  SVDMZ318B	Diode, Variable Capacitor (for FM) Diode, Switching, AGC & Detector (Product Part No. MA150)  Diode, Variable Capacitor (for AM) Diode, AM Detector Light Emitting Diode, Green Light Emitting Diode, Yellow Diode Diode, Synchronous Bias Diode, Detector & Relay Pulse Killer Rectifier Light Emitting Diode, Yellow Light Emitting Diode, Red Rectifier Rectifier  Diode, 18V Zener

Ref. No.	Part No.	Part Name & Description
D712, 715, 719, 720 D714  D717 D721 D901, 904~914, 916, 918~926, 940, 943, 945~947 D902 D903 D917  D927~933, 939 D934~938 D942 D944	SVDMZ316A  <b>SVDEQA0113RA</b>  SVDMZ307C1 SVDMZ304A <b>MA162A</b>  SVDMZ303A <b>2-0A90</b> <b>RVDRD6R2EB</b>  LN217RP LN417YP LN224RP SVDMZ327B	Diode, 16V Zener  Diode, 13V Zener (Product Part No. MA1130A) Diode, 8V Zener Diode, 4V Zener Diode (Product Part No. MA150)  Diode, 3V Zener Diode Diode, 6.2V Zener (Product Part No. MA1062A) Light Emitting Diode, Red Light Emitting Diode, Yellow Light Emitting Diode, Red Diode, 27V Zener
<b>COILS and TRANSFORMERS</b>		
L1 L2 L3, 4 L5 L6 L101 L102 L201 L202 L601, 602  L701, 702 L901 T101 T102 T201 T202 T701	SLA4P43 SLO4P67-P SLD4P35-P ELQ5A77 SLAA4W1-3 SLQW270-1K SLM1C61-P SLF2D69-1 SLO2C25-P SLQY15G-30  SLQX391 P RLQY2555-0 SLI4C511-K SLI4C513-K SLI2C127 SLI2C413R SLT5P201	Coil, FM Antenna Coil, FM Local Oscillator Coil, FM RF Detector Coil, Choke Coil, FM Antenna Balun Coil, Choke Coil, Choke Coil, AM Ferrite Bar Antenna Coil, AM Local Oscillator Coil, Choke  Coil, Choke Coil, Choke Transformer, FM IF Discriminator Transformer, FM IF Discriminator Transformer, AM IF Transformer, AM IF Transformer, Power Source
<b>CERAMIC FILTERS</b>		
CF101, 102, 103, 105  CF104  CF201	SVFE107MM-A SVFE107MM-B SVFE107MM-C SVFE107M22-A SVFE107M22-B SVFE107M22-C  SVFSFP450HT	Ceramic Filter, 10.7MHz (Red) Ceramic Filter, 10.68MHz (Blue) Ceramic Filter, 10.72MHz (Orange) Ceramic Filter, 10.7MHz (Red) Ceramic Filter, 10.675MHz (Blue) Ceramic Filter, 10.725MHz (Orange) (Use pair ranks as same as CF101~104 and 105)  Ceramic Filter, AM 450kHz
<b>CRYSTAL</b>		
X901	SVQ43U452	Crystal, Counter Oscillator (4.5MHz)
<b>VARIABLE RESISTORS</b>		
VR1-1, 1-2 VR2 VR3 VR4 VR101 VR102 VR301 VR302 VR303 VR603, 604	EUWMCB063BF5 EVBV35C20C15 EVBV37C20C15 EVAV32C20G25 <b>EVTS3MA00B34</b> <b>EVTS3MA00B24</b> <b>EVTS3MA00B53</b> <b>EVTS3MA00B14</b> <b>EVT80AA00B14</b> <b>EVNM4AA00B53</b>	Volume Control (with motor) Bass Control, 100kΩ(C) Treble Control, 100kΩ(C) Balance Control, 250kΩ(G) Muting Level Adjustment, 30kΩ(B) Signal LED Meter Adjustment, 20kΩ(B) PLL MPX Adjustment, 5kΩ(B) Normal Separation Adjustment, 10kΩ(B) Narrow Separation Adjustment, 10kΩ(B) ICQ Adjustment, 5kΩ(B)
<b>VARIABLE CAPACITORS</b>		
CT1 CT201	ECV1ZW06X32E ECV1ZW10X32	Trimmer, FM Local Oscillator Trimmer, AM Antenna
<b>THERMISTERS</b>		
TH101, 102 TH601, 602	ERTD2FHL103S ERTD2FHL103S	Thermister, Thermal Compensation, 10kΩ Thermister, Thermal Compensation, 10kΩ
<b>FUSES</b>		
F1 F2 F3, 4	XBA2C40TR0 XBA2C20TR0 XBA2C10TR0	Fuse, Power Source (T4.0A, 250V) Fuse, Power Source (T2.0A, 250V) Fuse, Power Source (T1.0A, 250V)

Ref. No.	Part No.	Part Name & Description
<b>LAMP</b>		
PL1	XAMR53S	Lamp, 6.3V 250mA
<b>COMPONENT COMBINATIONS</b>		
Z601, 602 Z701~705 Z901, 902 Z903, 904	ECQJ0517 EXRF5203ZS EXBP87104K EXFP7331M	Component Combination, 10Ω & 0.047μF Component Combination, 0.01μF (x2) Component Combination, 100kΩ (x7) Component Combination, 330pF (x7)
<b>FLUORESCENT DISPLAY TUBE</b>		
FL	SAD7MT09ZA	Fluorescent Display Tube
<b>RELAY</b>		
RLY1	SSY69	Relay, Speaker Protection
<b>SWITCHES</b>		
S1~5 S6~9, 12~14	SSH527 SSH707	Switch, Input Selector & Tape Monitor Switch, Audio Muting/Loudness/Subsonic Filter/High Filter/FM IF Band/FM Muting/ Auto Scan
S10, 11 S15 S16 S17, 18 S101, 913	SSH289 SSH119 ESE37200 SSG5 ESD14116	Switch, Speaker Selector Switch, Power Source Switch, Voltage Adjustment Switch, Volume "up" and "down" Switch, FM Antenna & FM/AM Allocation Selector
SS01~912	SSG1	Switch, Memory/Presel/FM-AM/Manual
<b>RESISTOR</b>		
R1	ERD25TJ104	Carbon, 100kΩ, 1/4W, ±5%
R2, 3	RRD18XK104	Chip, 100kΩ, 1/8W, ±10%
R4	RRD18XK223	Chip, 22kΩ, 1/8W, ±10%
R5	RRD18XK563	Chip, 56kΩ, 1/8W, ±10%
R6	ERD25FJ100	Carbon, 10Ω, 1/4W, ±5%
R7	RRD18XK223	Chip, 22kΩ, 1/8W, ±10%
R8	ERD10TJ470	Carbon, 47Ω, 1/8W, ±5%
R9	RRD18XK333	Chip, 33kΩ, 1/8W, ±10%
R10	RRD18XK103	Chip, 10kΩ, 1/8W, ±10%
R11	RRD18XK122	Chip, 1.2kΩ, 1/8W, ±10%
R12	RRD18XK102	Chip, 1kΩ, 1/8W, ±10%
R13	RRD18XK473	Chip, 47kΩ, 1/8W, ±10%
R14, 15	RRD18XK104	Chip, 100kΩ, 1/8W, ±10%
R16	RRD18XK221	Chip, 220Ω, 1/8W, ±10%
R17	RRD18XK472	Chip, 4.7kΩ, 1/8W, ±10%
R18	RRD18XK333	Chip, 33kΩ, 1/8W, ±10%
R19	RRD18XK822	Chip, 8.2kΩ, 1/8W, ±10%
R20	RRD18XK221	Chip, 220Ω, 1/8W, ±10%
R21	RRD18XK332	Chip, 3.3kΩ, 1/8W, ±10%
R22	RRD18XK333	Chip, 33kΩ, 1/8W, ±10%
R23	RRD18XK821	Chip, 820Ω, 1/8W, ±10%
R24	RRD18XK102	Chip, 1kΩ, 1/8W, ±10%
R25	RRD18XK821	Chip, 820Ω, 1/8W, ±10%
R27	RRD18XK222	Chip, 2.2kΩ, 1/8W, ±10%
R28	RRD18XK103	Chip, 10kΩ, 1/8W, ±10%
R29	RRD18XK104	Chip, 100kΩ, 1/8W, ±10%
R31	ERD25TJ563	Carbon, 56kΩ, 1/4W, ±5%
R32	ERD25TJ184	Carbon, 180kΩ, 1/4W, ±5%
R33	ERD25TJ104	Carbon, 100kΩ, 1/4W, ±5%
R101	RRD18XK681	Chip, 680Ω, 1/8W, ±10%
R102	RRD18XK222	Chip, 2.2kΩ, 1/8W, ±10%
R103, 104	RRD18XK331	Chip, 330Ω, 1/8W, ±10%
R105	RRD18XK152	Chip, 1.5kΩ, 1/8W, ±10%
R106	RRD18XK391	Chip, 390Ω, 1/8W, ±10%
R107	RRD18XK152	Chip, 1.5kΩ, 1/8W, ±10%
R108	RRD18XK331	Chip, 330Ω, 1/8W, ±10%
R109	RRD18XK221	Chip, 220Ω, 1/8W, ±10%
R110	RRD18XK562	Chip, 5.6kΩ, 1/8W, ±10%
R111	RRD18XK223	Chip, 22kΩ, 1/8W, ±10%
R112	RRD18XK562	Chip, 5.6kΩ, 1/8W, ±10%
R113	RRD18XK222	Chip, 2.2kΩ, 1/8W, ±10%
R114	RRD18XK104	Chip, 100kΩ, 1/8W, ±10%
R115	RRD18XK331	Chip, 330Ω, 1/8W, ±10%
R116	RRD18XK824	Chip, 820kΩ, 1/8W, ±10%
R117	RRD18XK153	Chip, 15kΩ, 1/8W, ±10%
R118	RRD18XK103	Chip, 10kΩ, 1/8W, ±10%
R119	ERD10TJ472	Carbon, 4.7kΩ, 1/8W, ±5%
R120	RRD18XK104	Chip, 100kΩ, 1/8W, ±10%
R121	RRD18XK103	Chip, 10kΩ, 1/8W, ±10%
R122	ERD10TJ470	Carbon, 47Ω, 1/8W, ±5%
R123	ERD25FJ472	Carbon, 4.7kΩ, 1/4W, ±5%
R124	ERD25CKF5801	Metal Film, 5.6kΩ, 1/4W, ±1%
R125	RRD18XK102	Chip, 1kΩ, 1/8W, ±10%
R127	RRD18XK223	Chip, 22kΩ, 1/8W, ±10%
R128	RRD18XK222	Chip, 2.2kΩ, 1/8W, ±10%

Ref. No.	Part No.	Part Name & Description
R129	RRD18XK473	Chip, 47kΩ, 1/8W, ±10%
R130	RRD18XK332	Chip, 3.3kΩ, 1/8W, ±10%
R131	RRD18XK333	Chip, 33kΩ, 1/8W, ±10%
R132	RRD18XK824	Chip, 820kΩ, 1/8W, ±10%
R133	RRD18XK103	Chip, 10kΩ, 1/8W, ±10%
R134	RRD18XK153	Chip, 15kΩ, 1/8W, ±10%
R135	RRD18XK102	Chip, 1kΩ, 1/8W, ±10%
R136	RRD18XK334	Chip, 330kΩ, 1/8W, ±10%
R137	RRD18XK473	Chip, 47kΩ, 1/8W, ±10%
R138	ERD25TJ104	Carbon, 100kΩ, 1/4W, ±5%
R139	RRD18XK183	Chip, 18kΩ, 1/8W, ±10%
R140	ERD25TJ823	Carbon, 82kΩ, 1/4W, ±5%
R141	RRD18XK103	Chip, 10kΩ, 1/8W, ±10%
R143	RRD18XK473	Chip, 47kΩ, 1/8W, ±10%
R144, 145	RRD18XK100	Chip, 10Ω, 1/8W, ±10%
R202	RRD18XK102	Chip, 1kΩ, 1/8W, ±10%
R203	RRD18XK104	Chip, 100kΩ, 1/8W, ±10%
R205	ERD10TJ562	Carbon, 5.6kΩ, 1/8W, ±5%
R206	RRD18XK333	Chip, 33kΩ, 1/8W, ±10%
R207	RRD18XK822	Chip, 8.2kΩ, 1/8W, ±10%
R208	RRD18XK222	Chip, 2.2kΩ, 1/8W, ±10%
R209	RRD18XK561	Chip, 560Ω, 1/8W, ±10%
R210	RRD18XK151	Chip, 150Ω, 1/8W, ±10%
R211	RRD18XK332	Chip, 3.3kΩ, 1/8W, ±10%
R212	RRD18XK102	Chip, 1kΩ, 1/8W, ±10%
R213	RRD18XK222	Chip, 2.2kΩ, 1/8W, ±10%
R214	RRD18XK103	Chip, 10kΩ, 1/8W, ±10%
R215	RRD18XK473	Chip, 47kΩ, 1/8W, ±10%
R216, 217	RRD18XK333	Chip, 33kΩ, 1/8W, ±10%
R218	RRD18XK394	Chip, 390kΩ, 1/8W, ±10%
R219	RRD18XK392	Chip, 3.9kΩ, 1/8W, ±10%
R220	RRD18XK222	Chip, 2.2kΩ, 1/8W, ±10%
R221	RRD18XK471	Chip, 470Ω, 1/8W, ±10%
R222	RRD18XK562	Chip, 5.6kΩ, 1/8W, ±10%
R223	RRD18XK103	Chip, 10kΩ, 1/8W, ±10%
R224	RRD18XK154	Chip, 150kΩ, 1/8W, ±10%
R225	RRD18XK273	Chip, 27kΩ, 1/8W, ±10%
R226	RRD18XK472	Chip, 4.7kΩ, 1/8W, ±10%
R227	RRD18XK102	Chip, 1kΩ, 1/8W, ±10%
R228	ERD10TJ473	Carbon, 47kΩ, 1/8W, ±5%
R230	ERD10TJ332	Carbon, 3.3kΩ, 1/8W, ±5%
R231	RRD18XK104	Chip, 100kΩ, 1/8W, ±10%
R232	ERD10TJ472	Carbon, 4.7kΩ, 1/8W, ±5%
R233	ERD10TJ473	Carbon, 47kΩ, 1/8W, ±5%
R301	RRD18XK103	Chip, 10kΩ, 1/8W, ±10%
R302	RRD18XK153	Chip, 15kΩ, 1/8W, ±10%
R303	RRD18XK101	Chip, 100Ω, 1/8W, ±10%
R304	RRD18XK102	Chip, 1kΩ, 1/8W, ±10%
R306	RRD18XK101	Chip, 100Ω, 1/8W, ±10%
R307	RRD18XK102	Chip, 1kΩ, 1/8W, ±10%
R308	RRD18XK103	Chip, 10kΩ, 1/8W, ±10%
R309, 310	RRD18XK392	Chip, 3.9kΩ, 1/8W, ±10%
R311, 312	RRD18XK103	Chip, 10kΩ, 1/8W, ±10%
R313, 314	RRD18XK103	Chip, 10kΩ, 1/8W, ±10%
R315, 316	RRD18XK474	Chip, 470kΩ, 1/8W, ±10%
R317, 318	RRD18XK471	Chip, 470Ω, 1/8W, ±10%
R319, 320	RRD18XK392	Chip, 3.9kΩ, 1/8W, ±10%
R321, 322	RRD18XK224	Chip, 220kΩ, 1/8W, ±10%
R323	RRD18XK104	Chip, 100kΩ, 1/8W, ±10%
R324	RRD18XK222	Chip, 2.2kΩ, 1/8W, ±10%
R401, 402	ERD25TJ104	Carbon, 100kΩ, 1/4W, ±5%
R403, 404	ERD10TJ221	Carbon, 220Ω, 1/8W, ±5%
R405, 406	ERD25TJ823	Carbon, 82kΩ, 1/4W, ±5%
R407, 408	ERD10TJ151	Carbon, 150Ω, 1/8W, ±5%
R409, 410	ERD10TJ332	Carbon, 3.3kΩ, 1/8W, ±5%
R411, 412	ERD25CKF5801	Metal Film, 6.8kΩ, 1/4W, ±1%
R413, 414	ERD25CKF1003	Metal Film, 100kΩ, 1/4W, ±1%
R415, 416	ERD10TJ471	Carbon, 470Ω, 1/8W, ±5%
R417, 418	ERD25TJ563	Carbon, 56kΩ, 1/4W, ±5%
R419, 420	ERD25TJ563	Carbon, 56kΩ, 1/4W, ±5%
R421, 422	ERD10TJ221	Carbon, 220Ω, 1/8W, ±5%
R423, 424	RRD18XK824	Chip, 820kΩ, 1/8W, ±10%
R425, 426	RRD18XK824	Chip, 820kΩ, 1/8W, ±10%
R427, 428	ERD10TJ472	Carbon, 4.7kΩ, 1/8W, ±5%
R429, 430	ERD10TJ472	Carbon, 4.7kΩ, 1/8W, ±5%
R431, 432	ERD25TJ394	Carbon, 390kΩ, 1/4W, ±5%
R433, 434	RRD18XK124	Chip, 120kΩ, 1/8W, ±10%
R435, 436	ERD25TJ184	Carbon, 180kΩ, 1/4W, ±5%
R437, 438	ERD10TJ472	Carbon, 4.7kΩ, 1/8W, ±5%
R439, 440	ERD25TJ824	Carbon, 820kΩ, 1/4W, ±5%
R441, 442	ERD25TJ104	Carbon, 100kΩ, 1/4W, ±5%
R443, 444	ERD10TJ103	Carbon, 10kΩ, 1/8W, ±5%
R445, 446	ERD10TJ393	Carbon, 39kΩ, 1/8W, ±5%



Ref. No.	Part No.	Part Name & Description
R447, 448	ERD25TJ104	Carbon, 100kΩ, 1/4W, ±5%
R449, 450	ERD25TJ824	Carbon, 820kΩ, 1/4W, ±5%
R451, 452	ERD10TJ122	Carbon, 1.2kΩ, 1/8W, ±5%
R453	ERD10TJ102	Carbon, 1kΩ, 1/8W, ±5%
R501, 502	ERD10TJ822	Carbon, 8.2kΩ, 1/8W, ±5%
R503, 504	ERD10TJ102	Carbon, 1kΩ, 1/8W, ±5%
R505, 506	ERD25TJ682	Carbon, 6.8kΩ, 1/4W, ±5%
R507, 508	ERD25TJ223	Carbon, 22kΩ, 1/4W, ±5%
R509, 510	ERD25TJ334	Carbon, 330kΩ, 1/4W, ±5%
R511, 512	ERD10TJ153	Carbon, 15kΩ, 1/8W, ±5%
R513, 514	ERD10TJ223	Carbon, 22kΩ, 1/8W, ±5%
R515, 516	ERD10TJ272	Carbon, 2.7kΩ, 1/8W, ±5%
R517, 518	ERD10TJ182	Carbon, 1.8kΩ, 1/8W, ±5%
R519, 520	ERD10TJ100	Carbon, 10Ω, 1/8W, ±5%
R521, 522	ERD10TJ223	Carbon, 22kΩ, 1/8W, ±5%
R523, 524	ERD25TJ564	Carbon, 560kΩ, 1/4W, ±5%
R525, 526	ERD10TJ223	Carbon, 22kΩ, 1/8W, ±5%
R527, 528	ERD10TJ223	Carbon, 22kΩ, 1/8W, ±5%
R601, 602	ERD10TJ152	Carbon, 15kΩ, 1/8W, ±5%
R603, 604	ERD25TJ104	Carbon, 100kΩ, 1/4W, ±5%
R605, 606	ERD10TJ222	Carbon, 2.2kΩ, 1/8W, ±5%
R607, 608	ERD25TJ184	Carbon, 180kΩ, 1/4W, ±5%
R609, 610	ERD10TJ183	Carbon, 18kΩ, 1/8W, ±5%
R611, 612	ERD10TJ183	Carbon, 18kΩ, 1/8W, ±5%
R613, 614	ERD10TJ682	Carbon, 6.8kΩ, 1/8W, ±5%
R615, 616	ERD10TJ221	Carbon, 220Ω, 1/8W, ±5%
R617, 618	ERD25FJ101	Carbon, 100Ω, 1/4W, ±5%
R619, 620	ERD25FJ101	Carbon, 100Ω, 1/4W, ±5%
R621, 622	ERD10TJ272	Carbon, 2.7kΩ, 1/8W, ±5%
R623, 624	ERD10TJ272	Carbon, 2.7kΩ, 1/8W, ±5%
R625, 626	ERD25FJ330	Carbon, 33Ω, 1/4W, ±5%
R627, 628	ERD25TJ683	Carbon, 68kΩ, 1/4W, ±5%
R629, 630	ERD10TJ473	Carbon, 47kΩ, 1/8W, ±5%
R631, 632	ERD25FJ271	Carbon, 270Ω, 1/4W, ±5%
R633, 634	ERD25FJ330	Carbon, 33Ω, 1/4W, ±5%
R635, 636	ERD25FJ472	Carbon, 4.7kΩ, 1/4W, ±5%
R637, 638	ERD10TJ332	Carbon, 3.3kΩ, 1/8W, ±5%
R639, 640	ERD25FJ222	Carbon, 2.2kΩ, 1/4W, ±5%
R641, 642	ERD10TJ333	Carbon, 33kΩ, 1/8W, ±5%
R643, 644	ERD10TJ222	Carbon, 2.2kΩ, 1/8W, ±5%
R645, 646	ERD50FJ562	Carbon, 5.6kΩ, 1/2W, ±5%
R647, 648	ERD50FJ562	Carbon, 5.6kΩ, 1/2W, ±5%
R649, 650	ERD50FJ100	Carbon, 10Ω, 1/2W, ±5%
R651, 652	ERD25FJ100	Carbon, 10Ω, 1/4W, ±5%
R653	ERD25FJ100	Carbon, 10Ω, 1/4W, ±5%
R655, 656	ERD25FJ391	Carbon, 390Ω, 1/4W, ±5%
R657, 658	ERD25TJ104	Carbon, 100kΩ, 1/4W, ±5%
R659, 660	ERD10TJ272	Carbon, 2.7kΩ, 1/8W, ±5%
R661, 662	ERD25TJ104	Carbon, 100kΩ, 1/4W, ±5%
R663	ERD10TJ333	Carbon, 33kΩ, 1/8W, ±5%
R664	ERD25FJ100	Carbon, 10Ω, 1/4W, ±5%
R665	ERD10TJ223	Carbon, 22kΩ, 1/8W, ±5%
R666	ERD10TJ153	Carbon, 15kΩ, 1/8W, ±5%
R667	ERD10TJ103	Carbon, 10kΩ, 1/8W, ±5%
R668	ERD10TJ822	Carbon, 8.2kΩ, 1/8W, ±5%
R669	ERD10TJ473	Carbon, 47kΩ, 1/8W, ±5%
R670	ERG1ANJ122	Metal Oxide, 1.2kΩ, 1W, ±5%
R671	ERD25TJ224	Carbon, 220kΩ, 1/4W, ±5%
R672	ERD25FJ100	Carbon, 10Ω, 1/4W, ±5%
R673	ERD10TJ102	Carbon, 1kΩ, 1/8W, ±5%
R674, 675	ERD10TJ103	Carbon, 10kΩ, 1/8W, ±5%
R676	ERD25TJ124	Carbon, 120kΩ, 1/4W, ±5%
R677	ERD25TJ153	Carbon, 15kΩ, 1/4W, ±5%
R678	ERG2ANJ331	Metal Oxide, 330Ω, 2W, ±5%
R679	ERD50FJ182	Carbon, 1.8kΩ, 1/2W, ±5%
R681, 682	ERG2ANJ331	Metal Oxide, 330Ω, 2W, ±5%
R690	ERD25TJ123	Carbon, 12kΩ, 1/4W, ±5%
R695	ERD25TJ473	Carbon, 47kΩ, 1/2W, ±5%
R701	ERD25FJ331	Carbon, 330Ω, 1/4W, ±5%
R702, 703	ERD50FJ222	Carbon, 2.2kΩ, 1/2W, ±5%
R704	ERG1ANJ681	Metal Oxide, 680Ω, 1W, ±5%
R705	ERD10TJ103	Carbon, 10kΩ, 1/8W, ±5%
R706	ERD50FJ220	Carbon, 22Ω, 1/2W, ±5%
R707	ERD10TJ151	Carbon, 150Ω, 1/8W, ±5%
R708	ERD10TJ122	Carbon, 1.2kΩ, 1/8W, ±5%
R709	ERD10TJ332	Carbon, 3.3kΩ, 1/8W, ±5%
R710	ERD10TJ471	Carbon, 470Ω, 1/8W, ±5%
R711	ERG1ANJ150	Metal Oxide, 15Ω, 1W, ±5%
R714	ERD10TJ100	Carbon, 10Ω, 1/8W, ±5%
R715	ERD10TJ680	Carbon, 68Ω, 1/8W, ±5%
R716	ERD10TJ390	Carbon, 39Ω, 1/8W, ±5%
R717	ERD10TJ100	Carbon, 10Ω, 1/8W, ±5%
R718	ERD10TJ472	Carbon, 4.7kΩ, 1/8W, ±5%

Ref. No.	Part No.	Part Name & Description
R719	ERD10TJ151	Carbon, 150Ω, 1/8W, ±5%
R720	ERD10TJ151	Carbon, 150Ω, 1/8W, ±5%
R721, 722	ERD10TJ151	Carbon, 150Ω, 1/8W, ±5%
R723	ERD10TJ682	Carbon, 6.8kΩ, 1/8W, ±5%
R724	ERD10TJ822	Carbon, 8.2kΩ, 1/8W, ±5%
R725	ERD25FJ100	Carbon, 10Ω, 1/4W, ±5%
R901, 902	RRD18XK102	Chip, 1kΩ, 1/8W, ±10%
R903	RRD18XK103	Chip, 10kΩ, 1/8W, ±10%
R904	RRD18XK223	Chip, 22kΩ, 1/8W, ±10%
R905	RRD18XK682	Chip, 6.8kΩ, 1/8W, ±10%
R906	RRD18XK822	Chip, 8.2kΩ, 1/8W, ±10%
R907	RRD18XK393	Chip, 39kΩ, 1/8W, ±10%
R908	RRD18XK104	Chip, 100kΩ, 1/8W, ±10%
R909	RRD18XK563	Chip, 56kΩ, 1/8W, ±10%
R910	RRD18XK104	Chip, 100kΩ, 1/8W, ±10%
R912	RRD18XK332	Chip, 3.3kΩ, 1/8W, ±10%
R913	RRD18XK152	Chip, 1.5kΩ, 1/8W, ±10%
R914	RRD18XK682	Chip, 6.8kΩ, 1/8W, ±10%
R915	RRD18XK153	Chip, 15kΩ, 1/8W, ±10%
R916	RRD18XK333	Chip, 33kΩ, 1/8W, ±10%
R917	RRD18XK100	Chip, 10Ω, 1/8W, ±10%
R918	RRD18XK102	Chip, 1kΩ, 1/8W, ±10%
R919	RRD18XK824	Chip, 820kΩ, 1/8W, ±10%
R920	RRD18XK104	Chip, 100kΩ, 1/8W, ±10%
R921	RRD18XK101	Chip, 100Ω, 1/8W, ±10%
R924	RRD18XK103	Chip, 10kΩ, 1/8W, ±10%
R925	ERD25CK F3302	Metal Film, 33kΩ, 1/4W, ±1%
R926	RRD18XK333	Chip, 33kΩ, 1/8W, ±10%
R927	RRD18XK152	Chip, 1.5kΩ, 1/8W, ±10%
R928	RRD18XK223	Chip, 22kΩ, 1/8W, ±10%
R929	RRD18XK333	Chip, 33kΩ, 1/8W, ±10%
R930	RRD18XK104	Chip, 100kΩ, 1/8W, ±10%
R931	ERD25TJ104	Carbon, 100kΩ, 1/4W, ±5%
R932	RRD18XK331	Chip, 330Ω, 1/8W, ±10%
R934	RRD18XK333	Chip, 33kΩ, 1/8W, ±10%
R935	RRD18XK223	Chip, 22kΩ, 1/8W, ±10%
R936	RRD18XK333	Chip, 33kΩ, 1/8W, ±10%
R937	RRD18XK473	Chip, 47kΩ, 1/8W, ±10%
R938	ERD10TJ473	Carbon, 47kΩ, 1/8W, ±5%
R939	ERD10TJ333	Carbon, 33kΩ, 1/8W, ±5%
R940	ERD10TJ182	Carbon, 1.8kΩ, 1/8W, ±5%
R941	ERD10TJ332	Carbon, 3.3kΩ, 1/8W, ±5%
R942	RRD18XK184	Chip, 180kΩ, 1/8W, ±10%
R943	ERD10TJ102	Carbon, 1kΩ, 1/8W, ±5%
R944	ERD25FJ152	Carbon, 1.5kΩ, 1/4W, ±5%
R945	RRD18XK102	Chip, 1kΩ, 1/8W, ±10%
R946, 947	RRD18XK100	Chip, 10Ω, 1/8W, ±10%
R948	RRD18XK100	Chip, 10Ω, 1/8W, ±10%
R949	RRD18XK102	Chip, 1kΩ, 1/8W, ±10%
R950, 951	RRD18XK100	Chip, 10Ω, 1/8W, ±10%
R955	RRD18XK101	Chip, 100Ω, 1/8W, ±10%
R958, 959	RRD18XK100	Chip, 10Ω, 1/8W, ±10%
<b>CAPACITOR</b>		
C1	ECUX1H103MD	Chip, 0.01μF, 50V, ±20%
C2, 3	ECKD1H102MD	Ceramic, 0.001μF, 50V, ±20%
[XAL] only		
C3	ECUX1H102ZF	Chip, 0.001μF, 50V, ±10%
[Except XAL]		
C4	ECUX1H010CC	Chip, 1pF, 50V, ±0.25pF
C6	ECUX1H040CC	Chip, 4pF, 50V, ±0.25pF
C7	ECUX1H102ZF	Chip, 0.001μF, 50V, ±10%
C8	ECUX1H103ZF	Chip, 0.01μF, 50V, ±10%
C10	ECUX1H050DC	Chip, 5pF, 50V, ±0.25pF
C11, 12	ECKD1H102MDA	Ceramic, 0.001μF, 50V, ±20%
C13	ECUX1H030DC	Chip, 3pF, 50V, ±0.25pF
C14	ECGN5R22K	Ceramic, 0.22pF, 500V, ±10%
C15	ECUX1H390KC	Chip, 39pF, 50V, ±10%
C16	ECUX1H102ZF	Chip, 0.001μF, 50V, ±10%
C17, 18	ECUX1H070DC	Chip, 7pF, 50V, ±0.5pF
C20	ECUX1H030DC	Chip, 3pF, 50V, ±0.25pF
C21	ECUX1H102ZF	Chip, 0.001μF, 50V, ±10%
C22	ECUX1H020CC	Chip, 2pF, 50V, ±0.25pF
C23, 24	ECUX1H050DC	Chip, 5pF, 50V, ±0.25pF
C25	ECUX1H020CC	Chip, 2pF, 50V, ±0.25pF
C26	ECUX1H102ZF	Chip, 0.001μF, 50V, ±10%
C27	ECUX1H050DC	Chip, 5pF, 50V, ±0.25pF
C28	ECUX1H181K	Chip, 180pF, 50V, ±10%
C29, 30	ECUX1H103ZF	Chip, 0.01μF, 50V, ±10%
C31	ECKD1H102MD	Ceramic, 0.001μF, 50V, ±20%
[XAL] only		
C40	ECCD1H220KC	Ceramic, 22pF, 50V, ±10%
C101, 102	ECUX1H223ZF	Chip, 0.022μF, 50V, ±10%
C103	ECUX1H103ZF	Chip, 0.01μF, 50V, ±10%

Ref. No.	Part No.	Part Name & Description
C104	ECUX1H560KC	Chip, 56pF, 50V, ±10%
C105, 106	ECUX1H1032F	Chip, 0.01μF, 50V, ±38%
C107, 108	ECUX1H223ZF	Chip, 0.022μF, 50V, ±38%
C109, 110	ECUX1H223ZF	Chip, 0.022μF, 50V, ±38%
C111	ECUX1H223ZF	Chip, 0.022μF, 50V, ±38%
C112	ECEA5021	Electrolytic, 1μF, 50V
C113, 114	ECUX1H223ZF	Chip, 0.022μF, 50V, ±38%
C115	ECUX1H223ZF	Chip, 0.022μF, 50V, ±38%
C116	ECUX1H1031K	Chip, 100pF, 50V, ±10%
C117	ECEA5021	Electrolytic, 1μF, 50V
C118	ECEA502R22	Electrolytic, 0.22μF, 50V
C119	ECEA1HS100	Electrolytic, 10μF, 50V
C120	ECEA502R47	Electrolytic, 0.47μF, 50V
C121, 122	ECKD1H223ZF	Ceramic, 0.022μF, 50V, ±38%
C123	ECUX1H470K	Chip, 47pF, 50V, ±10%
C124, 125	ECUX1H1032F	Chip, 0.01μF, 50V, ±38%
C126	ECUX1H1032F	Chip, 0.01μF, 50V, ±38%
C127	ECEA502R22	Electrolytic, 2.2μF, 50V
C128	ECUX1H1032F	Chip, 0.01μF, 50V, ±38%
C130	ECEA5023R3	Electrolytic, 3.3μF, 50V
C135	ECKD1H223ZF	Ceramic, 0.022μF, 50V, ±20%
C201	ECUX1H223ZF	Chip, 0.022μF, 50V, ±38%
C202	ECQM1H473KZ	Polyester, 0.047μF, 50V, ±10%
C203	ECUX1H100KC	Chip, 100pF, 50V, ±10%
C204	ECQP1241JZ	Polypropylene, 240pF, 100V, ±5%
C205	ECUX1H223ZF	Chip, 0.022μF, 50V, ±38%
C206	ECUX1H590KC	Chip, 39pF, 50V, ±10%
C207	ECUX1H223ZF	Chip, 0.022μF, 50V, ±38%
C208	ECUX1H1032F	Chip, 0.01μF, 50V, ±38%
C209	ECUX1H103MD	Chip, 0.01μF, 50V, ±20%
C210, 211	ECUX1H223ZF	Chip, 0.022μF, 50V, ±38%
C212	ECEA1JS4R7	Electrolytic, 4.7μF, 63V
C213	ECUX1H470KC	Chip, 47pF, 50V, ±10%
C214	ECUX1H1032F	Chip, 0.01μF, 50V, ±38%
C215	ECUX1H223ZF	Chip, 0.022μF, 50V, ±38%
C216, 217	ECUX1H1032F	Chip, 0.01μF, 50V, ±38%
C218	ECUX1H1032F	Chip, 0.01μF, 50V, ±38%
C219	ECQM1H473KZ	Polyester, 0.047μF, 50V, ±10%
C220	ECEA5021	Electrolytic, 1μF, 50V
C231	ECKD1H102MD	Ceramic, 0.001μF, 50V, ±20%
[XAL] only		
C301	ECQP1471JZ	Polypropylene, 470pF, 100V, ±5%
C302	ECEA1CS221	Electrolytic, 220μF, 16V
C303	ECEA50M4R7R	Electrolytic, 4.7μF, 50V
C304	ECEA502R22	Electrolytic, 0.22μF, 50V
C305	ECEA502R47	Electrolytic, 0.47μF, 50V
C306	ECEA1CS471	Electrolytic, 470μF, 16V
C307	ECEA502R47	Electrolytic, 0.47μF, 50V
C308	ECQM1H473KZ	Polyester, 0.047μF, 50V, ±10%
C309, 310	ECQM1H123JZ	Polyester, 0.012μF, 50V, ±5%
C311, 312	ECEA5021	Electrolytic, 1μF, 50V
C313, 314	ECQM1H272JZ	Polyester, 0.0027μF, 50V, ±5%
C315, 316	ECUX1H471MD	Chip, 470pF, 50V, ±20%
C317, 318	ECQM1H222KZ	Polyester, 0.0022μF, 50V, ±10%
C319, 320	ECEA5021	Electrolytic, 1μF, 50V
C321	ECEA502R47	Electrolytic, 0.47μF, 50V
C401, 402	ECEA50M3R3R	Electrolytic, 3.3μF, 50V
C403, 404	FCCD1H101K	Ceramic, 100pF, 50V, ±10%
C405, 406	ECKD1H331KB	Ceramic, 330pF, 50V, ±10%
C407, 408	ECEA1AS101	Electrolytic, 100μF, 10V
C409, 410	ECKD1H222MD	Ceramic, 0.0022μF, 50V, ±20%
C411, 412	ECQP1103GZ	Polypropylene, 0.01μF, 100V, ±2%
C413, 414	ECQM1H102JZ	Polyester, 0.001μF, 50V, ±5%
C415, 416	ECQP1393GZ	Polypropylene, 0.039μF, 100V, ±2%
C417, 418	ECEA1HN47S	Non-polar Electrolytic, 0.47μF, 50V
C419, 420	ECQM1H222KZ	Polyester, 0.0022μF, 50V, ±10%
C421, 422	ECEA5021	Electrolytic, 1μF, 50V
C423	ECKD1H333MD	Ceramic, 0.033μF, 50V, ±20%
C425, 426	ECCD1H820K	Ceramic, 82pF, 50V, ±10%
C427, 428	ECQM1H472KZ	Polyester, 0.0047μF, 50V, ±10%
C429, 430	ECQM1H473KZ	Polyester, 0.047μF, 50V, ±10%
C431, 432	ECQM1H473KZ	Polyester, 0.047μF, 50V, ±10%
C501, 502	ECQM1H152KZ	Polyester, 0.0015μF, 50V, ±10%

Ref. No.	Part No.	Part Name & Description
C503, 504	ECQM1H223KZ	Polyester, 0.022μF, 50V, ±10%
C505, 506	ECQM1H123JZ	Polyester, 0.012μF, 50V, ±5%
C507, 508	ECQM1H104KZ	Polyester, 0.1μF, 50V, ±10%
C509, 510	ECEA1CS330	Electrolytic, 33μF, 16V
C511, 512	ECEA2524R7	Electrolytic, 4.7μF, 25V
C513, 514	ECCD1H020C	Ceramic, 20pF, 50V, ±0.25pF
C515, 516	ECEA1AS221	Electrolytic, 220μF, 10V
C517, 518	ECEA5023R3	Electrolytic, 3.3μF, 50V
C519, 520	ECQS1271JZ	Polypropylene, 270pF, 125V, ±5%
C521, 522	ECQM1H332KZ	Polyester, 0.0033μF, 50V, ±10%
C601, 602	ECEA50M3R3R	Electrolytic, 3.3μF, 50V
C603, 604	ECCD1H101K	Ceramic, 100pF, 50V, ±10%
C605, 606	ECCD1H680K	Ceramic, 68pF, 50V, ±10%
C607, 608	ECKD1H621KB	Ceramic, 820pF, 50V, ±10%
C609, 610	ECCD2H180K	Ceramic, 180pF, 500V, ±10%
C611, 612	ECEA2AS3R3	Electrolytic, 3.3μF, 100V
C613, 614	ECCD1H270K	Ceramic, 27pF, 50V, ±10%
C615, 616	ECCD1H220K	Ceramic, 22pF, 50V, ±10%
C621, 622	ECEA1HN3R3S	Non-polar Electrolytic, 3.3μF, 50V
C623	ECEA1CN101S	Non polar Electrolytic, 100μF, 16V
C624	ECEA502R22	Electrolytic, 2.2μF, 50V
C625	ECEA5021	Electrolytic, 1μF, 50V
C626	ECEA2AS100	Electrolytic, 10μF, 100V
C627	ECEA1CS330	Electrolytic, 33μF, 16V
C628	ECEA502R47	Electrolytic, 0.47μF, 50V
C701, 702	ECKDKC103PF	Ceramic, 0.01μF, 400V AC, ±10%
C703, 704	ECETS1HV822U	Electrolytic, 8200pF, 50V
C705	ECEA1VS221	Electrolytic, 220μF, 35V
C706	ECEA1JS221	Electrolytic, 220μF, 63V
C707	ECEA1VS101	Electrolytic, 100μF, 35V
C708	ECEA1JS101	Electrolytic, 100μF, 63V
C710	ECKD1H1032F	Ceramic, 0.01μF, 50V, ±38%
C711	ECEA1ES101	Electrolytic, 100μF, 25V
C712	ECEA1VS331	Electrolytic, 330μF, 35V
C713	ECEA1ES101	Electrolytic, 100μF, 25V
C714, 715	ECKD1H1032F	Ceramic, 0.01μF, 50V, ±38%
C716	ECEA1ES101	Electrolytic, 100μF, 25V
C717	ECEA1VS471	Electrolytic, 470μF, 35V
C718	ECEA1VS221	Electrolytic, 220μF, 35V
C719	ECEA1AS221	Electrolytic, 220μF, 10V
C720	ECEA1CS471	Electrolytic, 470μF, 16V
C721	ECEA1ES101	Electrolytic, 100μF, 25V
C722, 723	ECEA1ES101	Electrolytic, 100μF, 25V
C724, 725	ECKD1H1032F	Ceramic, 0.01μF, 50V, ±38%
C726	ECKD1H1032F	Ceramic, 0.01μF, 50V, ±38%
C727	ECEA1CN100S	Non-polar Electrolytic, 10μF, 16V
C728, 729	ECKY2H102WES	Ceramic, 0.001μF, 100V, ±20%
C901	ECEA1HS101	Electrolytic, 100μF, 50V
C902	ECUX1H1032F	Chip, 0.01μF, 50V, ±38%
C903	ECEA50M2R2R	Electrolytic, 2.2μF, 50V
C904, 905	ECUX1H1032F	Chip, 0.01μF, 50V, ±38%
C906	ECEA50M3R3R	Electrolytic, 0.33μF, 50V
C907	ECEA1AS221	Electrolytic, 220μF, 10V
C908	ECUX1H1032F	Chip, 0.01μF, 50V, ±38%
C909	ECEA1AS101	Electrolytic, 100μF, 10V
C910	ECEA1HS100	Electrolytic, 10μF, 50V
C911	ECUX1H223ZF	Chip, 0.022μF, 50V, ±38%
C912	ECUX1H1032F	Chip, 0.01μF, 50V, ±38%
C913	ECQM1H333KZ	Polyester, 0.033μF, 50V, ±10%
C914	ECEA1CS330	Electrolytic, 33μF, 16V
C915	ECUX1H220KC	Chip, 22pF, 50V, ±10%
C916	ECUX1H180KC	Chip, 18pF, 50V, ±10%
C917	ECUX1H080DC	Chip, 8pF, 50V, ±0.5pF
C918	ECUX1H223ZF	Chip, 0.022μF, 50V, ±38%
C919	ECEA04S102	Electrolytic, 1000μF, 6.3V
C920	ECEA1HS470	Electrolytic, 47μF, 50V
C921	ECEA1AS102	Electrolytic, 1000μF, 10V
C922	ECUX1H223ZF	Chip, 0.022μF, 50V, ±38%
C923	ECKD1H223ZF	Ceramic, 0.022μF, 50V, ±38%
C925, 926	ECEA1HS100	Electrolytic, 10μF, 50V
C927	ECEA5023R3	Electrolytic, 3.3μF, 50V
C928	ECUX1H1032F	Chip, 0.01μF, 50V, ±38%
C936	ECKD1H223ZF	Ceramic, 0.022μF, 50V, ±38%

# EXPLODED VIEWS

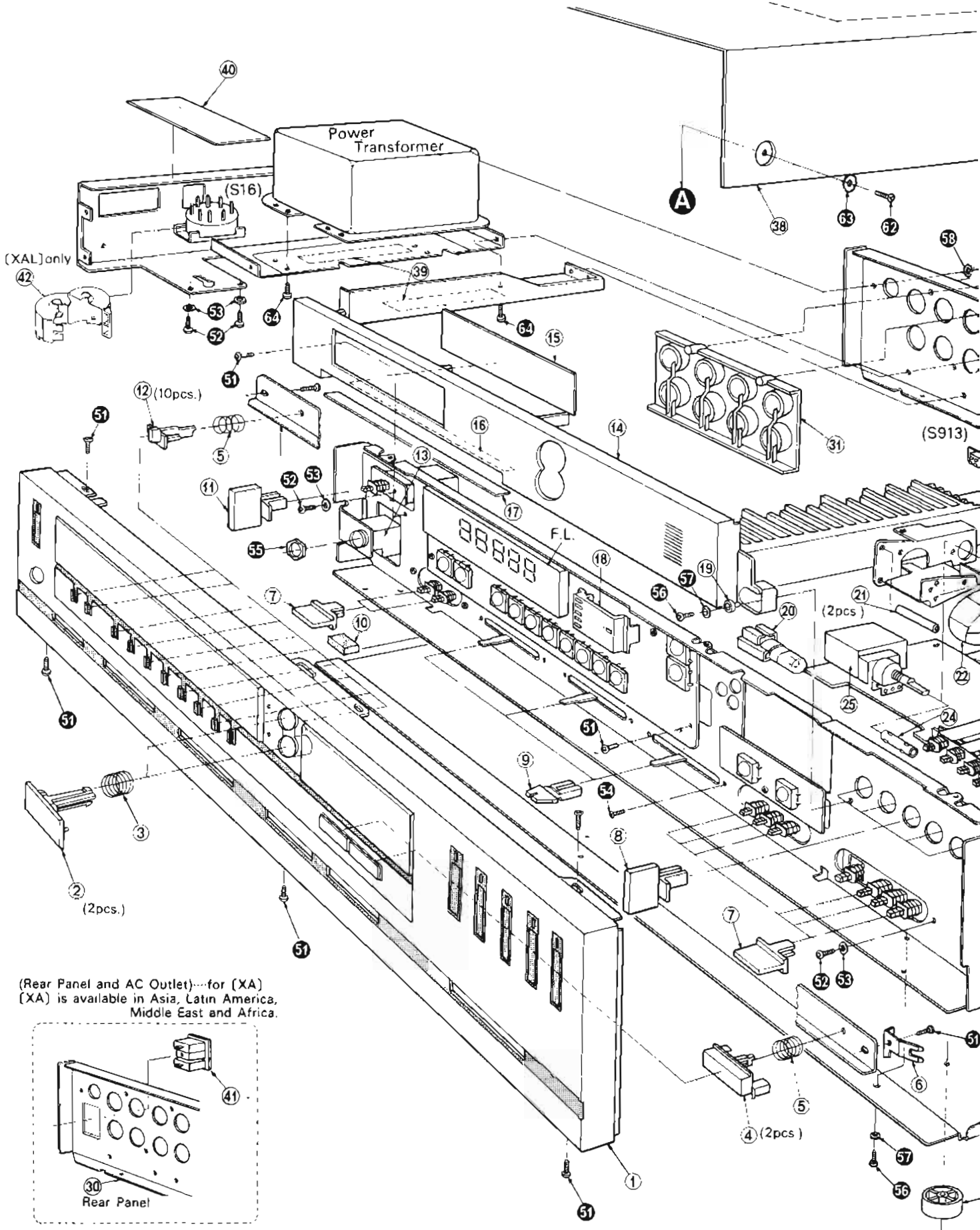

(Rear Panel and AC Outlet)---for (XA)  
 (XA) is available in Asia, Latin America,  
 Middle East and Africa.

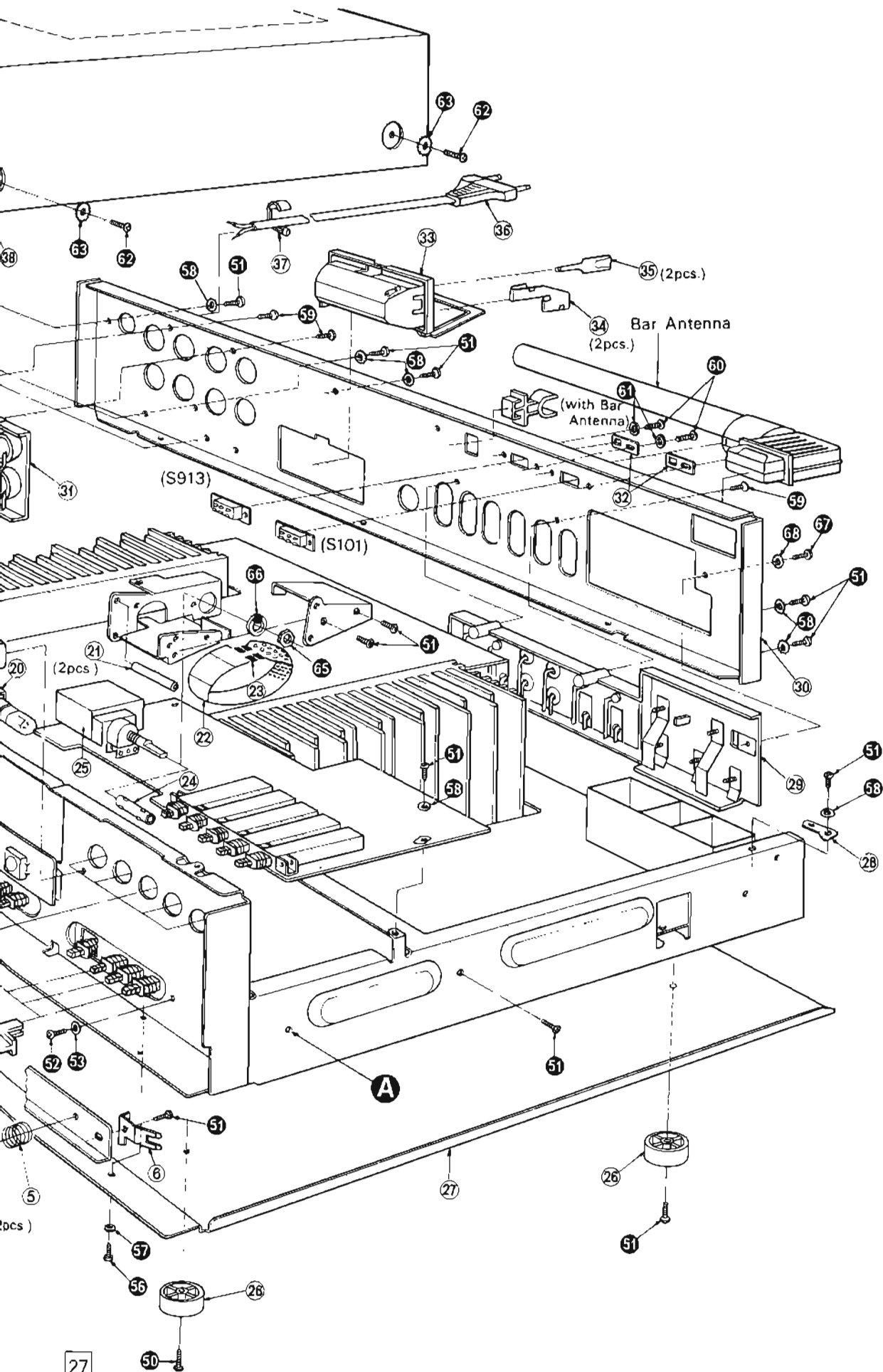

Lead wire connector (an example)

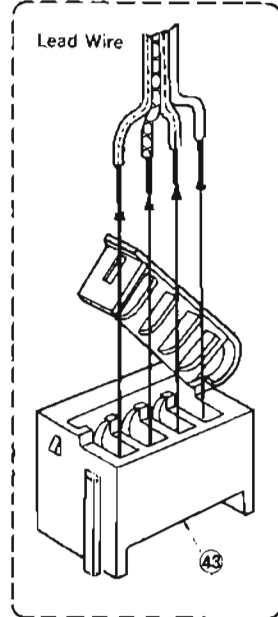

## REPLACEMENT PARTS LIST ..... Cabinet and Chassis Parts

- Notes:** 1. Parts numbers are indicated on most mechanical parts. Please use this part number for parts orders.  
 2.  $\Delta$  indicates that only parts specified by the manufacturer be used for safety.  
 3. **KB** -marked parts are used for black type only, while **O** -marked parts are for silver type only.

4. Parts other than **KB** and **O** -marked are used for both black and silver types.  
 5. Bracketed indications in Ref. No. columns specify the area. Parts without these indications can be used for all areas.

Black type model No. SA-515 (K)

Ref. No.	Part No.	Part Name & Description
<b>CABINET and CHASSIS PARTS</b>		
1	$\Delta$ SGWA515E	Panel, Front Assy
1	$\Delta$ SGWA515KE	Panel, Front Assy (Black)
2	SBC296	Button, Tuning Up/Down Switch
3	SUS271	Spring, Tuning Up/Down Switch
4	SBC297	Button, Volume Up/Down Switch
5	SUS163	Spring, Push Switches
6	SUS186-1	Spring, Ear
7	SBC303	Button, Push Switches
7	SBC303-1	Button, Push Switches (Black)
8	SBC301-2	Button, Selector and Tape Switches
8	SBC301-3	Button, Selector and Tape Switches (Black)
8	SBC305	Button, Balance, Treble and Bass
8	SBC305-1	Button, Balance, Treble and Bass (Black)
10	SHG1537	Rubber Cushion, Front Panel
11	SBC301	Button, Power Switch
11	SBC301-1	Button, Power Switch (Black)
17	SBC295	Button, FM, AM, Preset tuning and Memory Switches
13	KCJ6P216-A1	Jack, Headphones
14	SGK6647	Ornament, Fluorescent Display Tube
14	$\Delta$ SGK6647-1	Ornament, Fluorescent Display Tube (Black)
15	SDU291	Filter, Display Window
16	SHR9333	Paper, Ornament Indicator Window
17	SHR9331	Paper, Ornament Indicator Window
18	SHR9519	Cover, Signal Level Indicator
19	SHR9339	Sealer, F. L. Ornament Mtg
20	SZ2703	Socket, Pilot Lamp
21	SUJ849	Film, Volume Level Film
22	SDU45	Film, Volume Level
22	SHR9521	Hinge, Volume Level Film Lock
24	SDG9001	Gear, Volume
25	SPC236	Cover, Volume
26	SKL227	Foot, Set
27	SKU8830	Bottom Board
28	RJT2026	Terminal, Ground
29	SJF8029-2N	Terminal, Antenna and Input
30 [E]	SGP2410-3A	Rear Panel
30 [XA]	SGP2410-4N	Rear Panel
30 [XAL]	SGP2410-5N	Rear Panel
30 [G, E, XGH]	SGPA515E	Rear Panel, SGP2410-3A with Name Plate (SG12990)
31	SJF4813	Terminal, Speakers
32	SHR5073-1	Stopper, FM Antenna/Allocation Selector
33	SJB3005	Case, Battery
34	SJC9	Terminal, Battery Case
35	SAC7	Terminal, Battery Case
36	$\Delta$ SJAB8	AC Cord
36 [XAL] only	$\Delta$ QFC1207M	AC Cord

Ref. No.	Part No.	Part Name & Description
37	SHR127	Bushing, AC Cord
37 [XAL] only	SHR131	Bushing, AC Cord
38	SKC550H1	Cabinet
38	SKC550B1	Cabinet (Black)
39	SHS2457	Filter
40	SMA367	Cover, Fuse P.C.B
41 [XA] only	SUS466-2	Socket, AC Outlet
42 [XAL] only	SUV453	Cover, Voltage Adjuster
43	SUS527	Connector, Lead Wire, 4-pin
43	SUS9421	Connector, Lead Wire, 4-pin
43	SUS5627	Connector, Lead Wire, 6-pin
43	SUS9419	Connector, Lead Wire, 6-pin
<b>SCREWS, WASHERS and NUTS</b>		
①	XTB3-8BFZ	Screw, Tapping, $\phi$ 3x8
②	XSN3-6S	Screw, $\phi$ 3x6
③	XWA30	Washer, Spring, $\phi$ 3
④	XN2-4BV5	Screw, $\phi$ 2x4
⑤	XN2E12	Nut, M12 (Headphone Jack)
⑥	XTV3-8BFN	Screw, Tapping, $\phi$ 3x8
⑦	XWG3	Washer, Plain, $\phi$ 3
⑧	XWC36	Washer, External, Toothed Lock, $\phi$ 3
⑨	XTB3-10BFZ	Screw, Tapping, $\phi$ 3x10
⑩	XSN3-6BV5	Screw, $\phi$ 3x6
⑪	XWA3BFZ	Washer, Spring, $\phi$ 3
⑫	XTB4-8BFZ	Screw, Tapping, $\phi$ 4x8 (Cabinet)
⑬	XTB4-8BFN	Screw, Tapping, $\phi$ 4x8 (Cabinet)
⑭	XWC48	Washer, External, Toothed Lock, $\phi$ 4
⑮	XTB4-8BFN	Screw, Tapping, $\phi$ 4x8 (Transformer & Bottom Board)
⑯	XN58	Nut, M5
⑰	XWV8	Washer, Spring, $\phi$ 8
⑱	XTB3-8BFZ	Screw, Tapping, $\phi$ 3 x 8
⑳	XTS3-8Z	Screw, $\phi$ 3 x 8
㉑	XWC36	Washer, External, Toothed Lock, $\phi$ 3
<b>ACCESSORIES</b>		
A1	SSA267	Cord, FM Indoor Antenna
A2 [XA] only	SJP5213-1	Plug Adapter, AC Power
<b>PACKING PARTS</b>		
P1	SPR051	Polyethylene Bag
P2	SPS2839	Pad, Left Side
P2 [XAL] only	SPS2839-1	Pad, Left Side
P3	SPS2841	Pad, Right Side
P3 [XAL] only	SPS2841-1	Pad, Right Side
P4	SPG2723	Carton Box
P4 [XAL] only	SPG2725	Carton Box
P5	SQI10601	Instructions Book, Printed Master
P5 [XA] only	SQI10605	Instructions Book, Printed Master

### Areas

- \* [E] and [EG] are available in Scandinavia and European.
- \* [XAL] is available in Australia.
- \* [XA] is available in Asia, Latin America, Middle East and Africa.
- \* [XGH] is available in Holland.
- \* [EB] is available in Belgium.

### ● Accessories

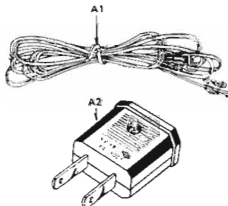

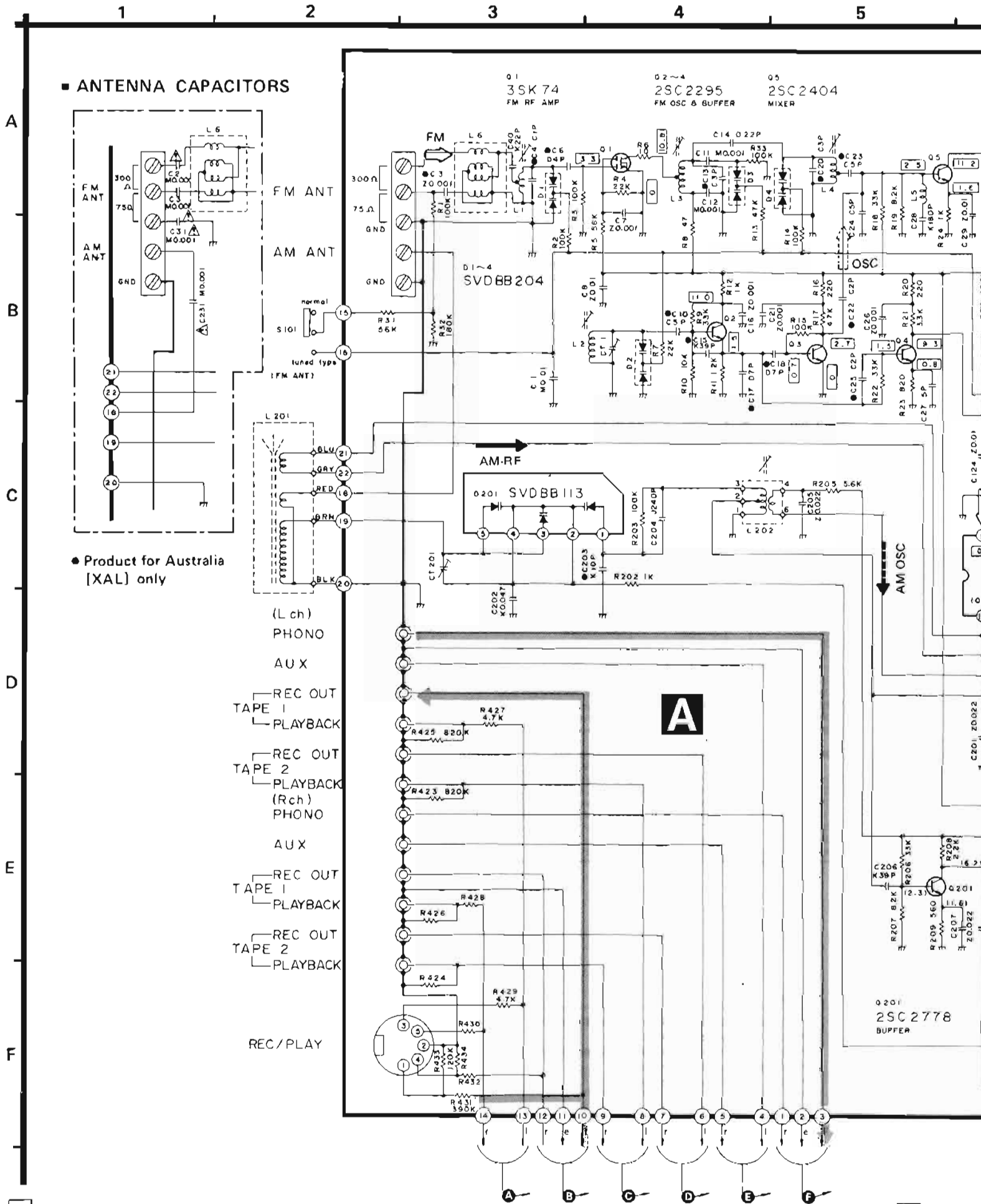

( This schematic diagram may be modified at any time with the development of new technology.)

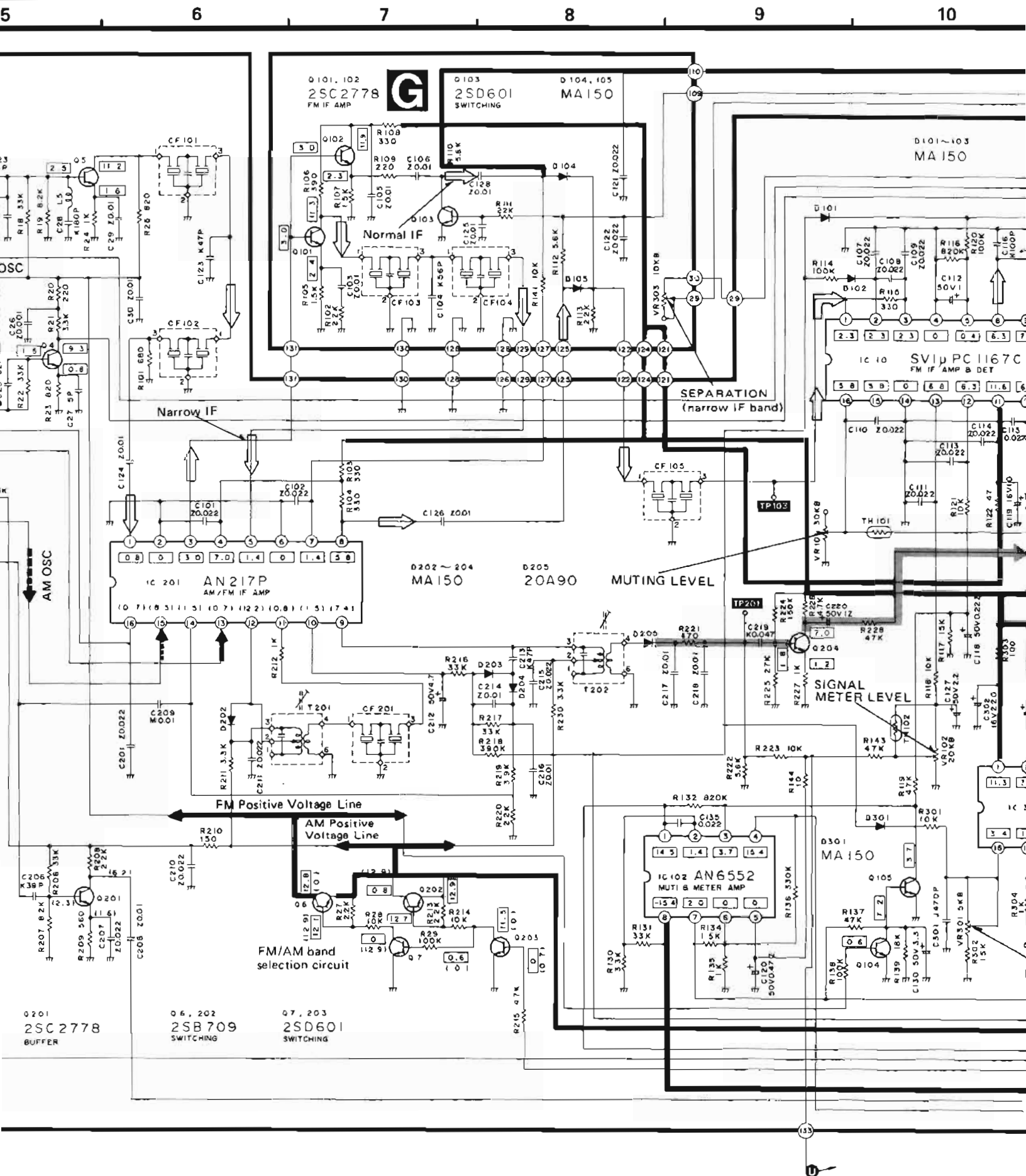

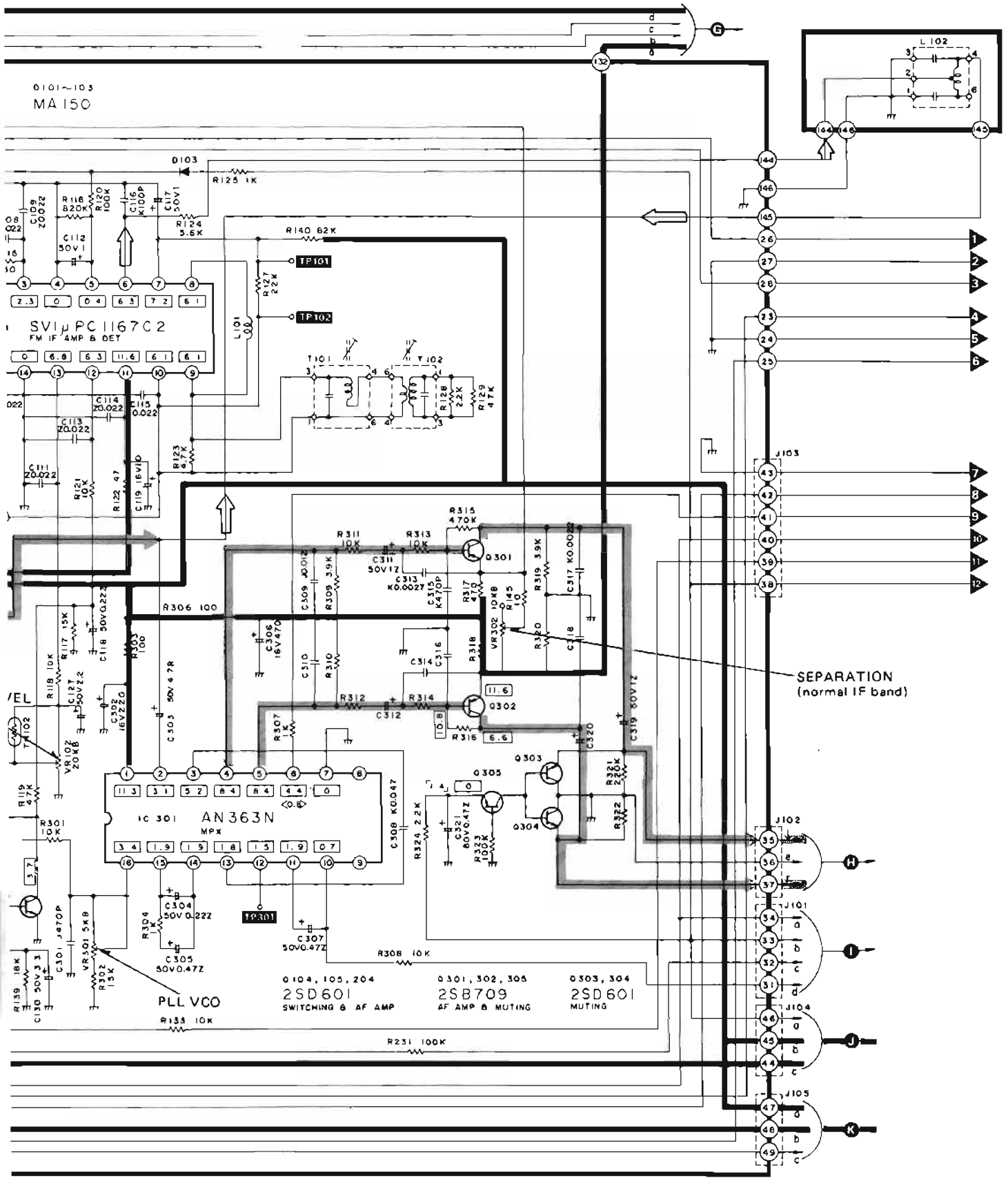







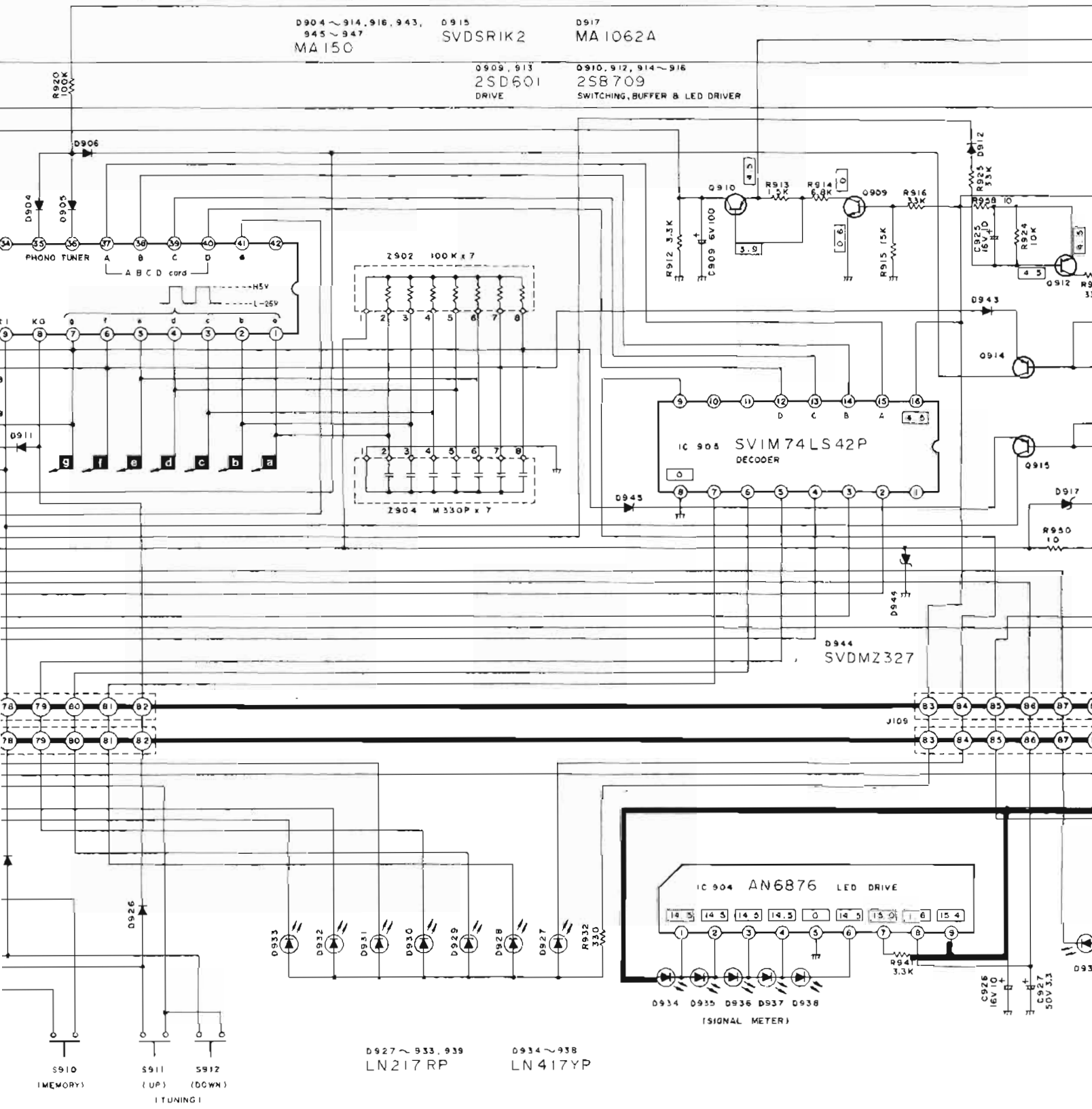

D904 ~ 914, 916, 943, 945 ~ 947  
MA150

D915  
SVDSRIK2

D917  
MA1062A

0909, 913  
2SD601  
DRIVE

0910, 917, 914 ~ 916  
2SB709  
SWITCHING, BUFFER & LED DRIVER

Z902 100K x 7

Z904 M 330P x 7

IC 905 SVIM74LS42P  
DECODER

D944  
SVDMZ327

IC 904 AN6876 LED DRIVE

(SIGNAL METER)

D927 ~ 933, 939  
LN217RP

D934 ~ 938  
LN417YP

S910 (MEMORY)

S911 (UP)

S912 (DOWN)

TUNING I

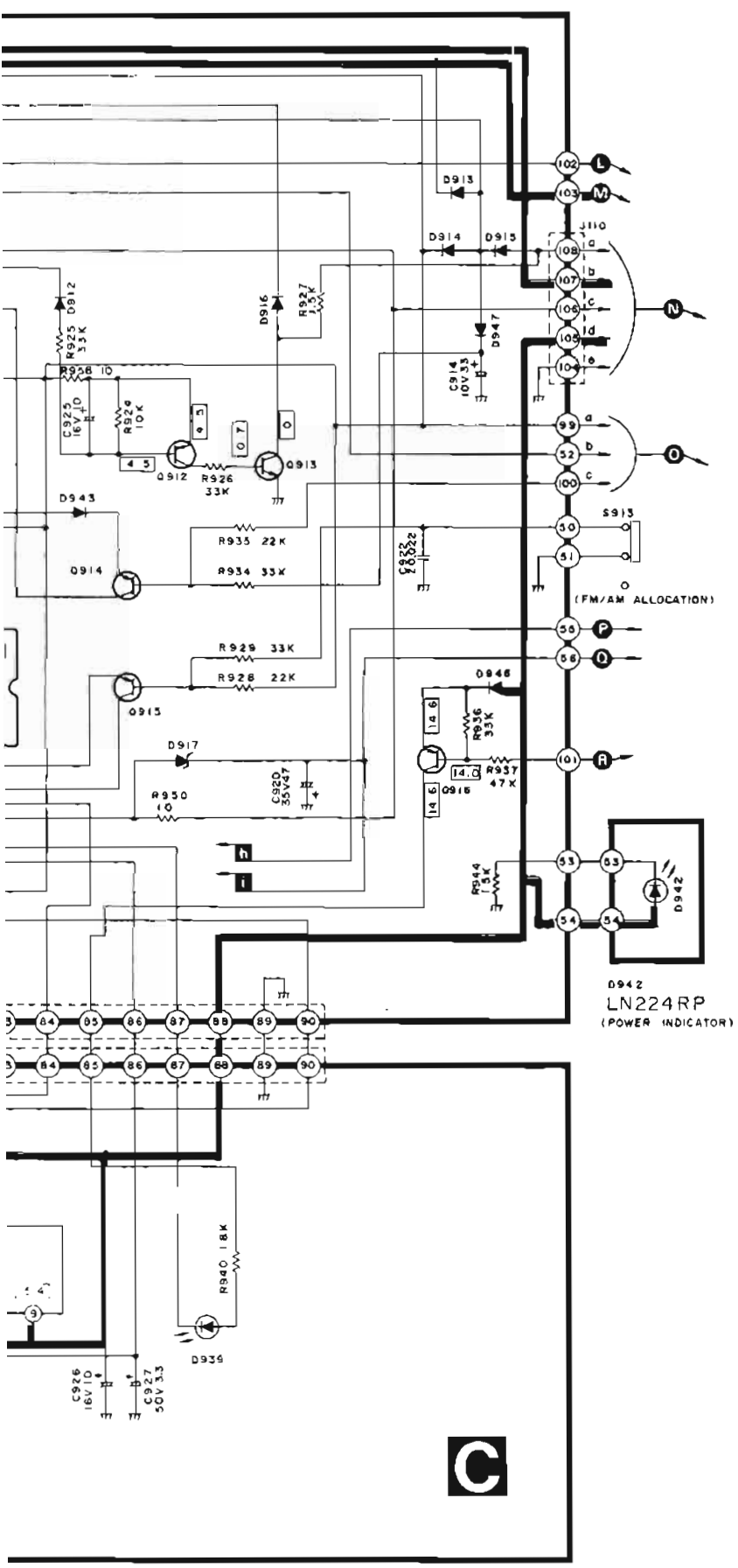

- Notes:
- S1~S3:** Input selector switch in "tuner" position. (S1: phono, S2: tuner, S3: AUX.)
  - S4, S5:** Tape monitor switch in "Source" position. (S4: Tape 2, S5: Tape 1)
  - S6:** Audio muting switch in "0dB" position. 0dB ↔ -20dB
  - S7:** Loudness switch in "off" position.
  - S8:** Subsonic filter switch in "off" position.
  - S9:** High filter switch in "off" position.
  - S10, S11:** Speaker selector, switch in "main" position. (S10: main, S11 remote)
  - S12:** FM IF band selector switch in "normal" position. normal ↔ narrow
  - S13:** FM muting/FM mode selector switch in "on/FM auto" position. on/FM auto ↔ off/FM mono
  - S14:** Automatic - scan switch in "on" position.
  - S15:** Power source switch in "on" position.
  - S16:** Voltage adjustment switch in "240V" position.
  - S17:** Volume "down" switch.
  - S18:** Volume "up" switch.
  - S101:** FM antenna selector switch in "normal" position. normal ↔ tuned type
  - S901:** FM tuner selector switch.
  - S902:** AM tuner selector switch.
  - S903~S909:** Preset tuning switch. S903 - 1ch, S904 - 2ch, S905 - 3ch, S906 - 4ch, S907 - 5ch, S908 - 6ch, S909 - 7ch
  - S910:** Memory set switch.
  - S911:** Manual tuning "up" switch
  - S912:** Manual tuning "down" switch.
  - S913:** FM/AM allocation selector switch in "FM 0.05MHz/AM 9KHz" step position. FM 0.2MHz/AM 10KHz ↔ FM 0.05MHz/AM 9KHz
23. Indicated voltage values are the standard values for the unit measured by the DC electronic circuit tester (high-impedance) with the chassis taken as standard. Therefore, there may exist some errors in the voltage values, depending on the internal impedance of the DC circuit tester.
- \* Figures in  $\square$  stand for DC voltage in FM/AM signal reception mode.
  - \* Figures in  $\langle \rangle$  stand for DC voltage in FM stereo signal reception mode.
  - \* Figures in  $\sim$  stand for DC voltage in FM (no signal) muting to on mode.
  - \* Figures in  $\{ \}$  stand for DC voltage with the FM/AM selector circuit set at AM.
  - \*  $\square$  marked terminal: 5V or 0V output.
  - \*  $\blacksquare$  marked terminal: 5V or -26V output.
24. Transistor and IC terminals which carry no voltage indication emit 5V pulse waveforms or are subject to change according to the frequency or input signal levels.
25. Signal lines
- $\Rightarrow$  FM/AM composite signal
  - $\Rightarrow$  Audio frequency signal
  - $\Rightarrow$  Positive voltage lines
  - $\Rightarrow$  AM signal
26.  $\triangle$  indicates that only parts specified by the manufacturer be used for safety.



PRINTED CIRCUIT BOARD

Ground (Earth) lines

A

A

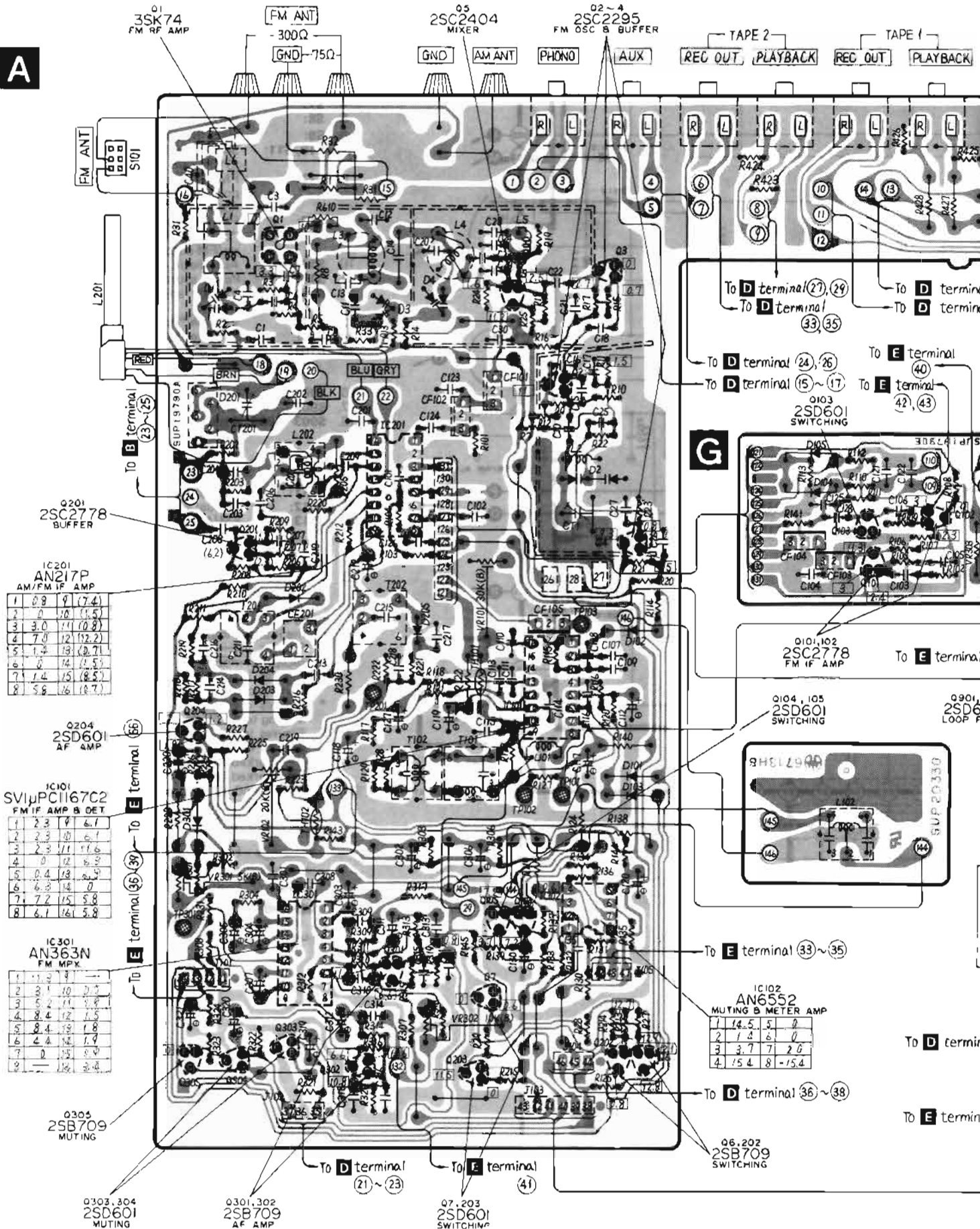

G

## A Tuner circuit

## B Logic control circuit

## G FM IF amp. circuit

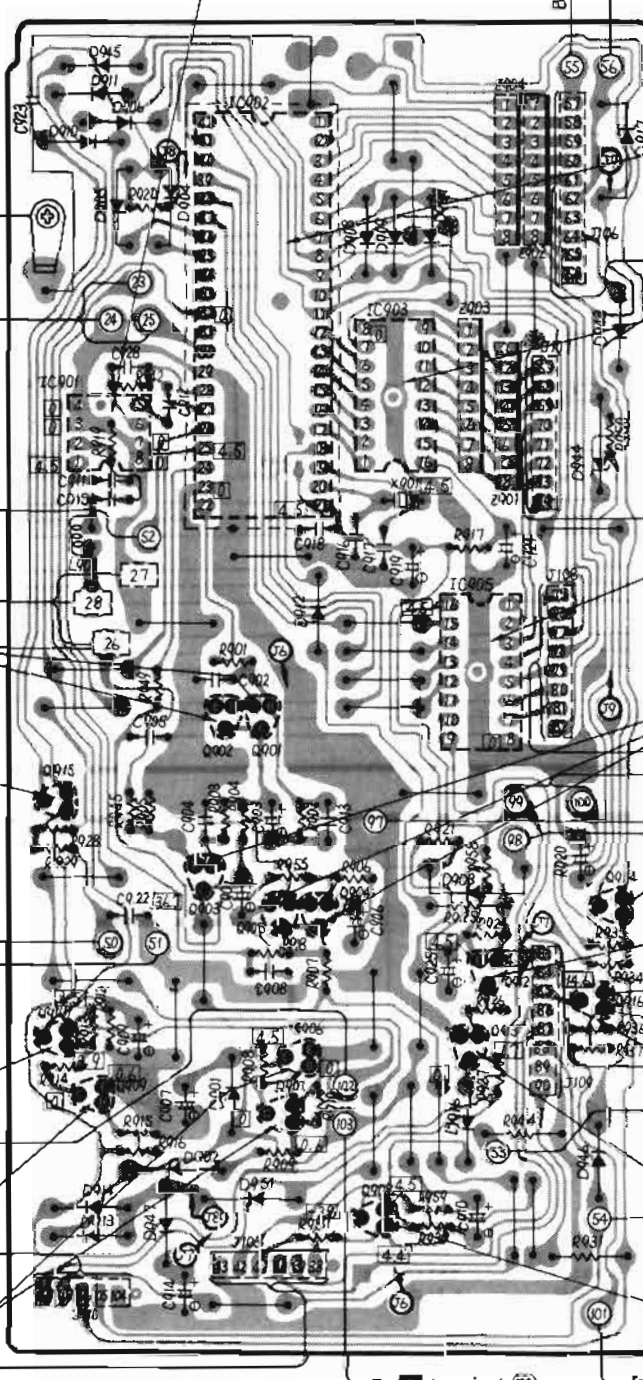
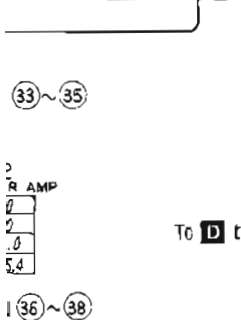
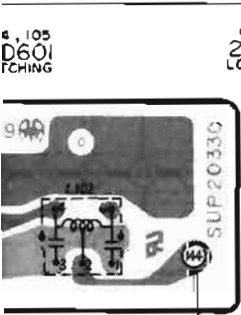
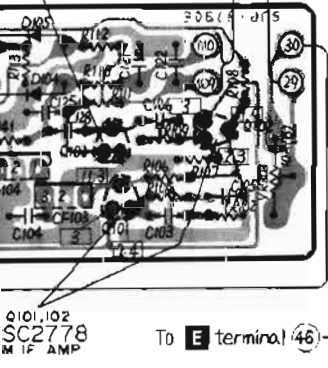
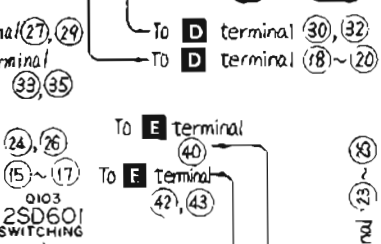
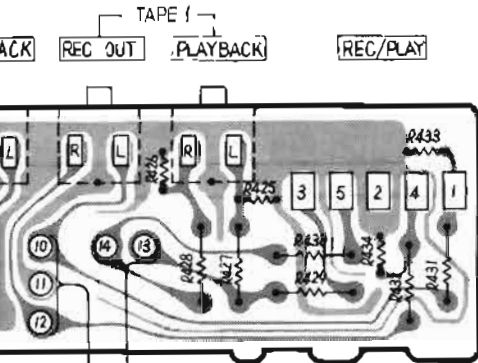





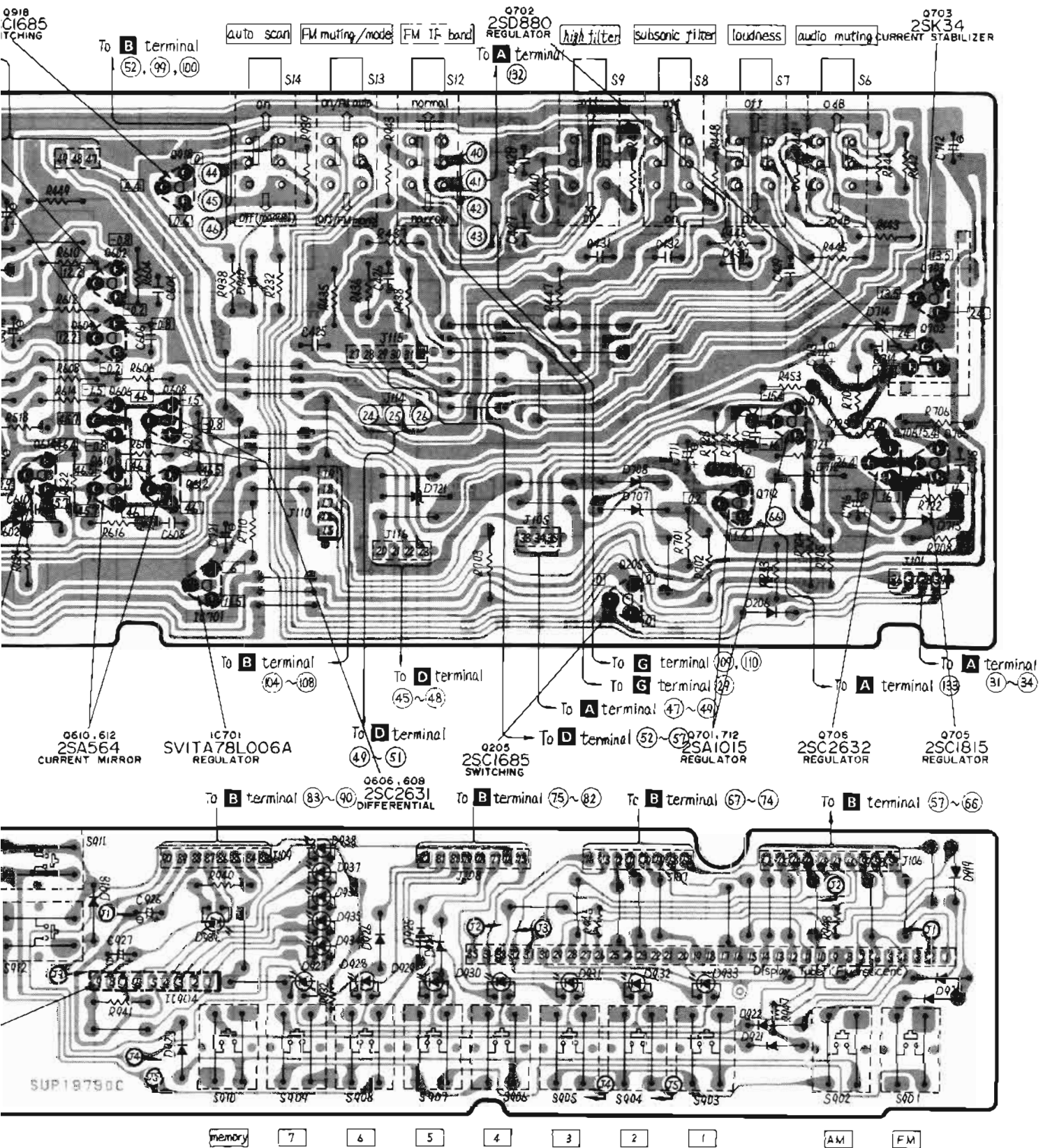

**C** LED display circuit



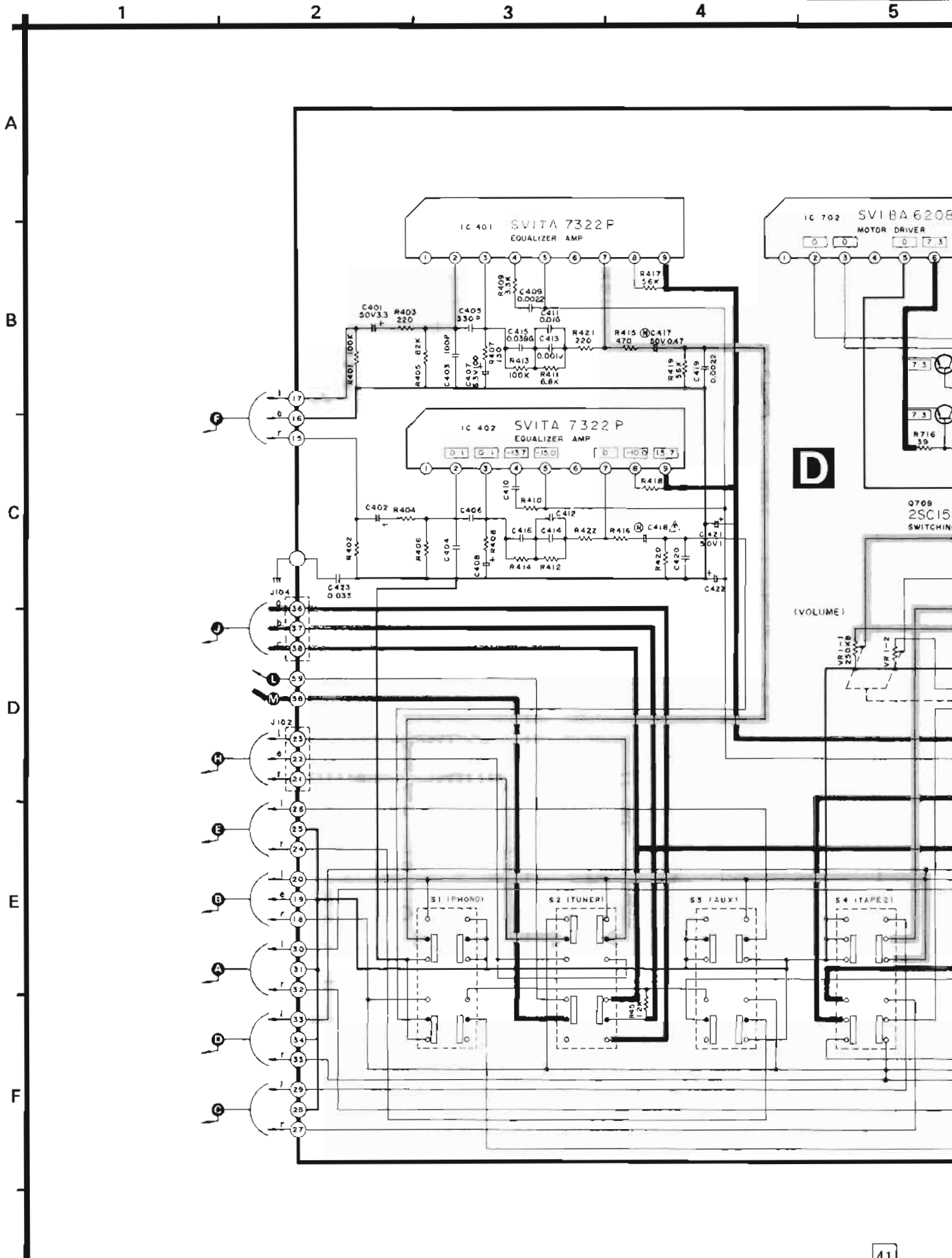

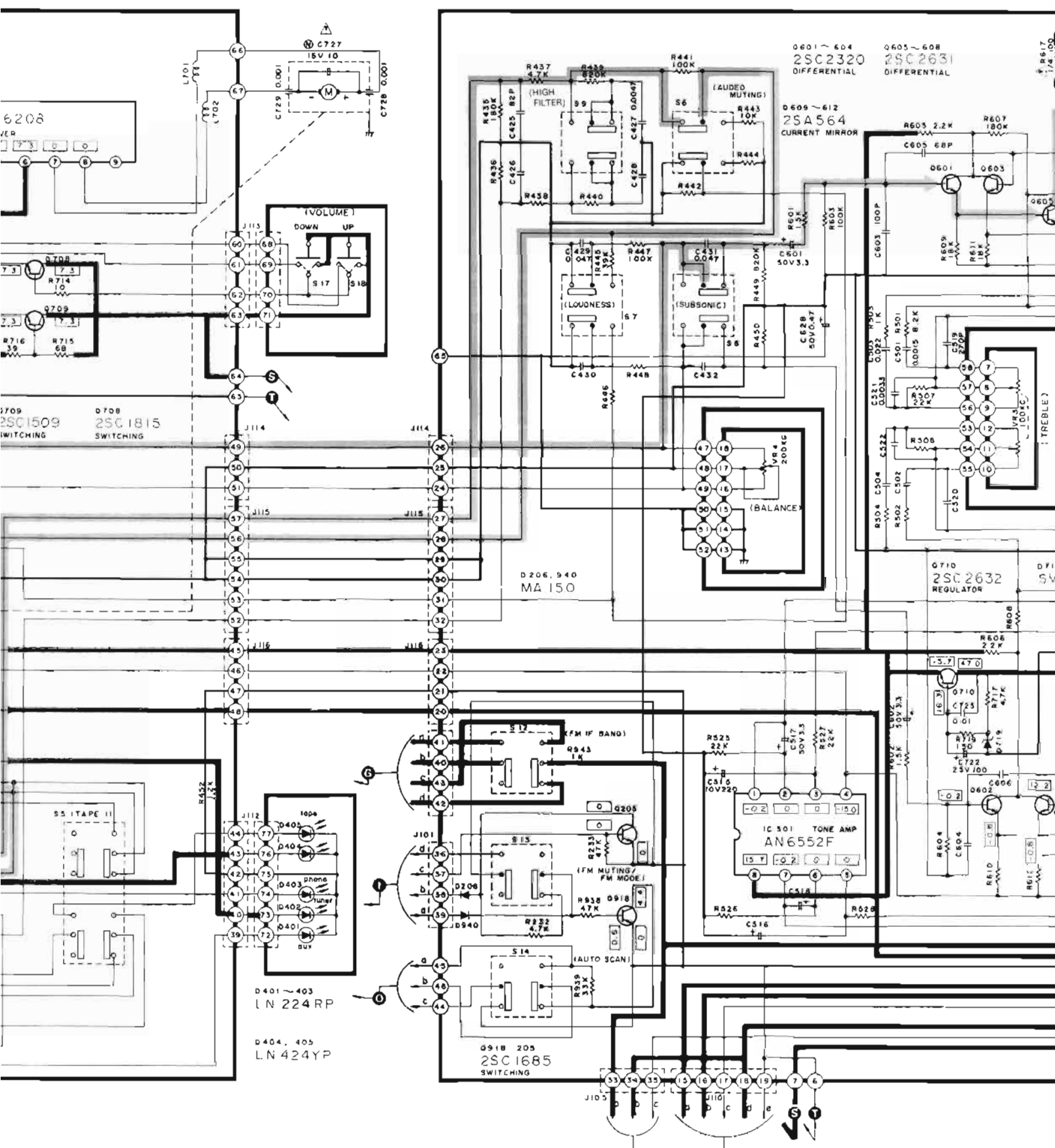

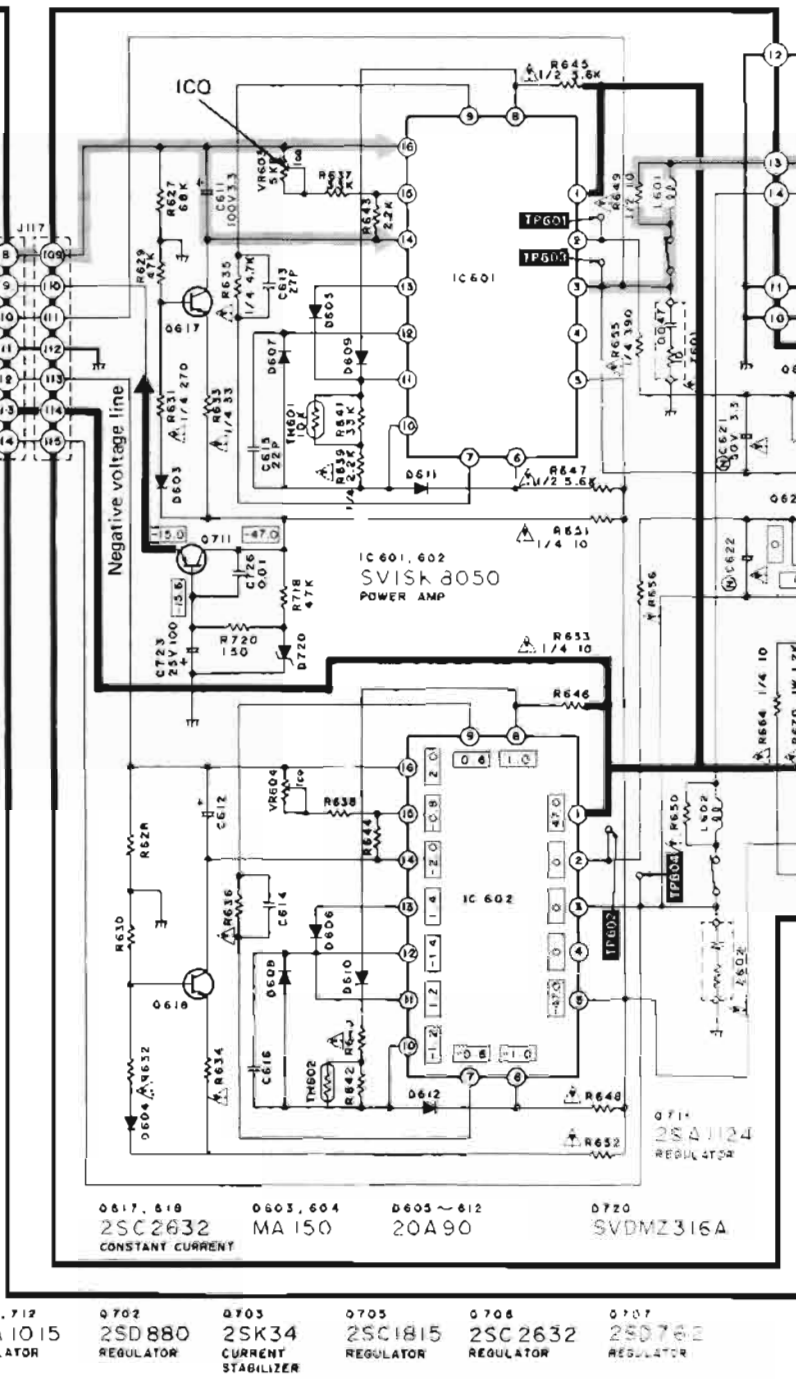
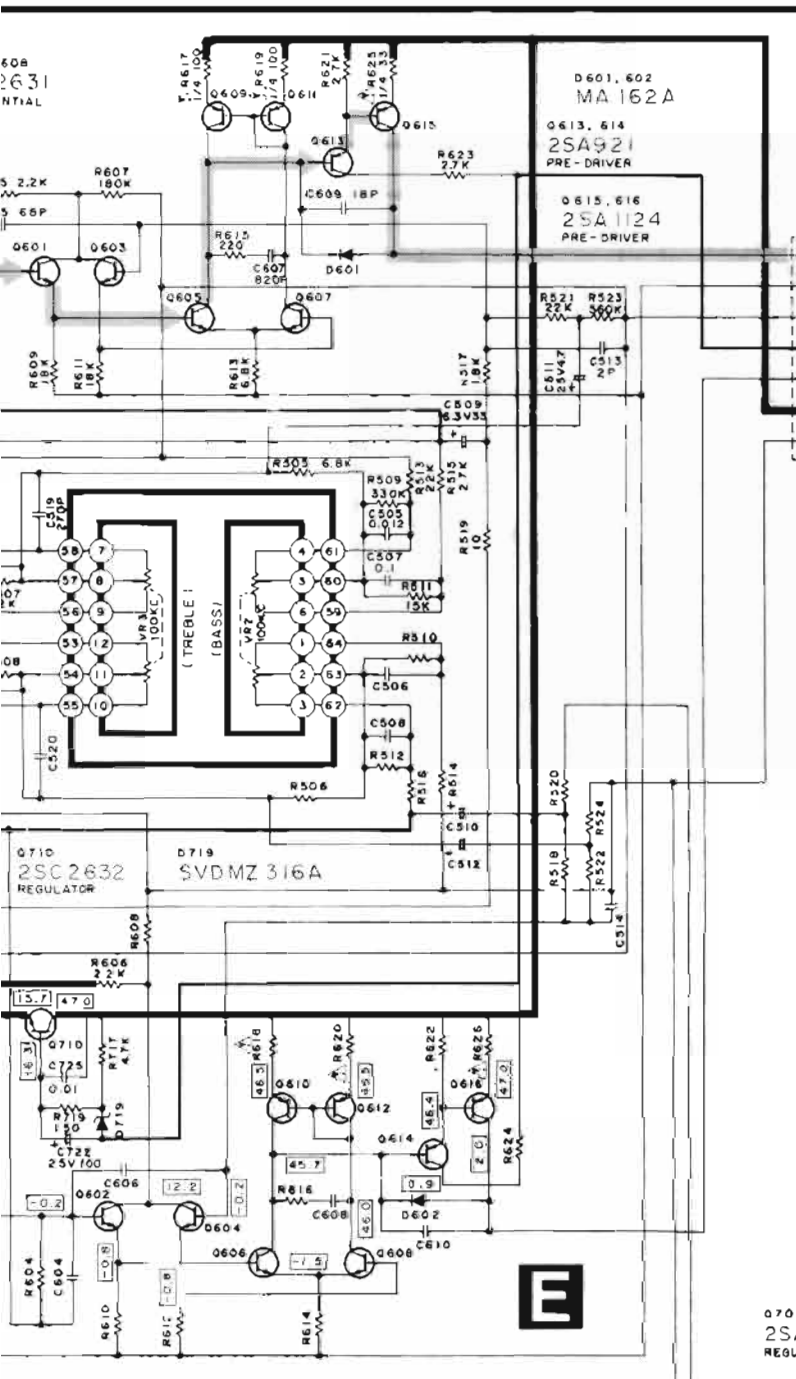

- |                                    |           |                    |           |           |           |
|------------------------------------|-----------|--------------------|-----------|-----------|-----------|
| Q701, 712                          | Q702      | Q703               | Q705      | Q706      | Q707      |
| 2SA1015                            | 2SD880    | 2SK34              | 2SC1815   | 2SC2632   | 2SD762    |
| REGULATOR                          | REGULATOR | CURRENT STABILIZER | REGULATOR | REGULATOR | REGULATOR |
| D705, 706, 709, 710, 713, 716, 718 | D707, 708 | D712, 715          | D717      |           |           |
| SVDSR1K2                           | SVDMZ318B | SVDMZ316A          | SVDMZ307  |           |           |

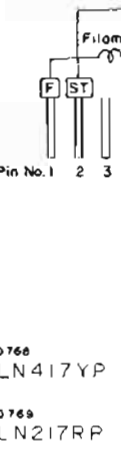
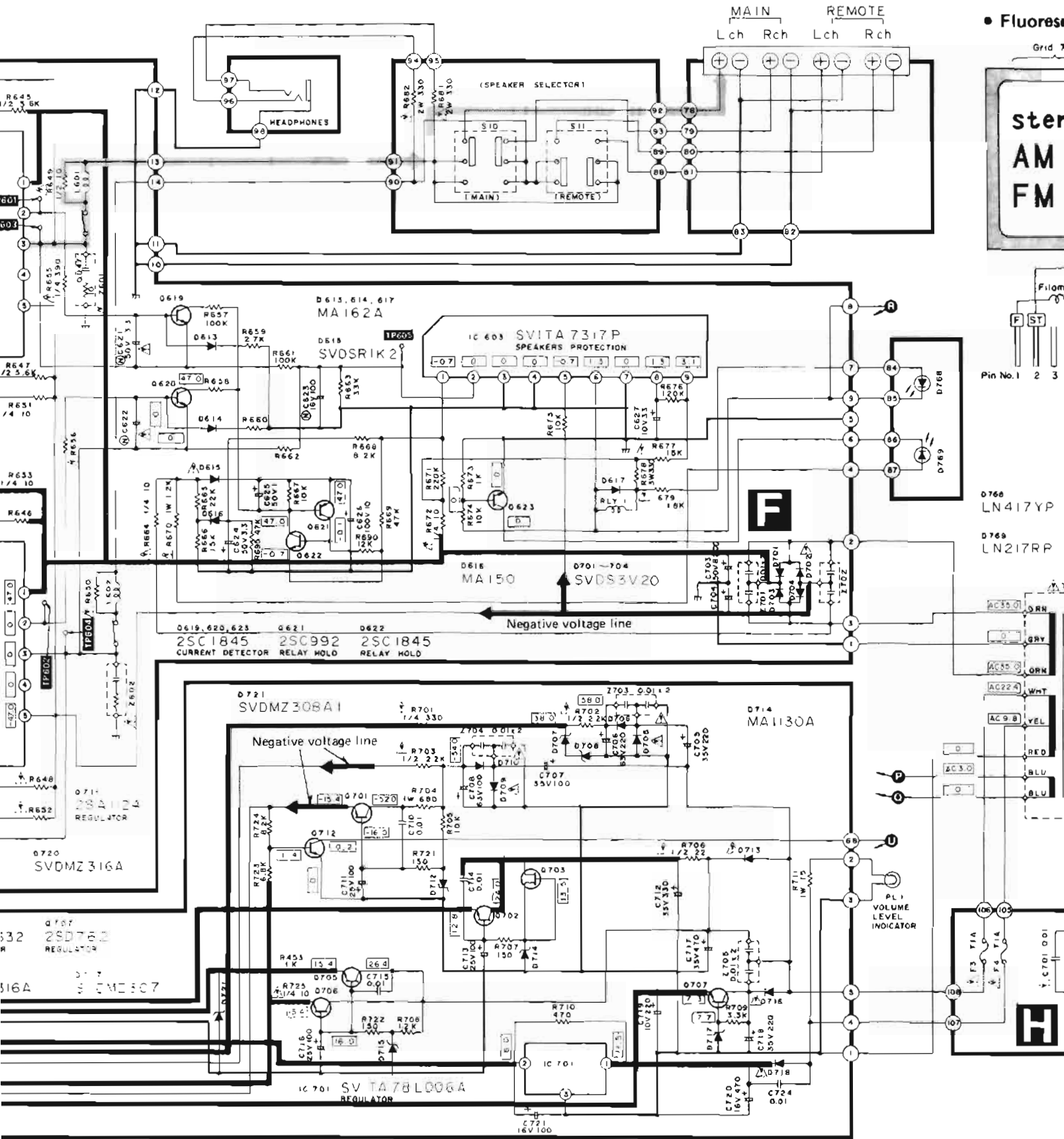

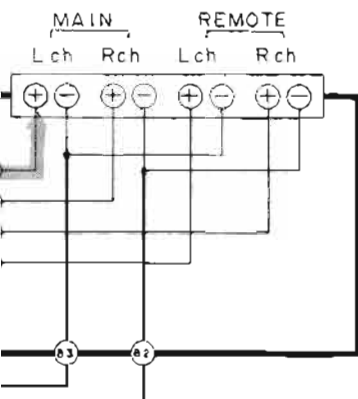

• Fluorescent Display Tube (FL)

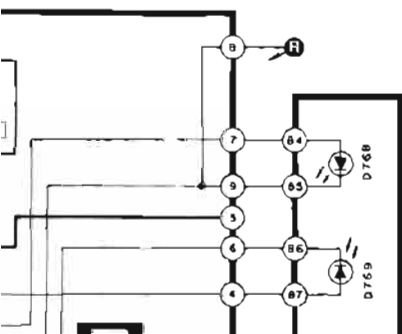
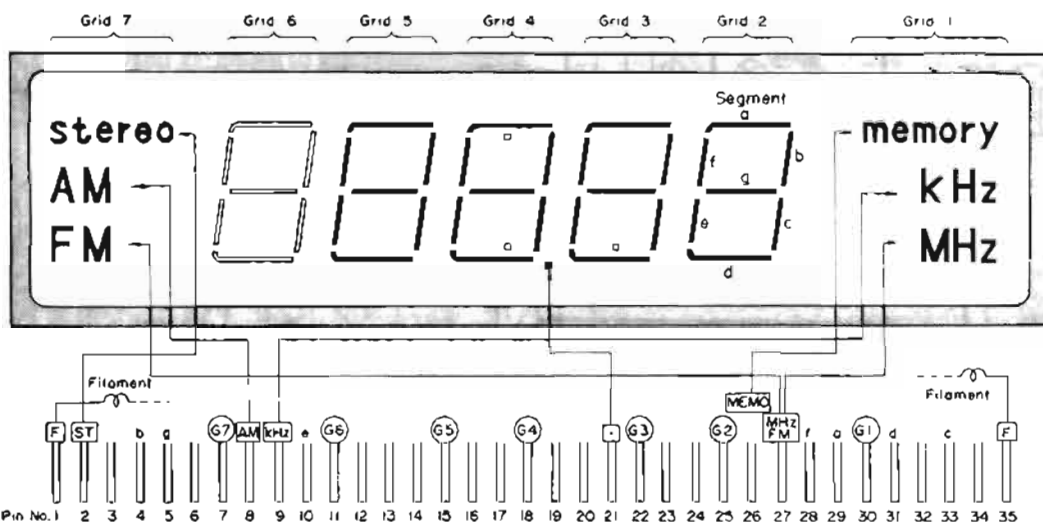

D768  
LN417YP

D769  
LN217RP

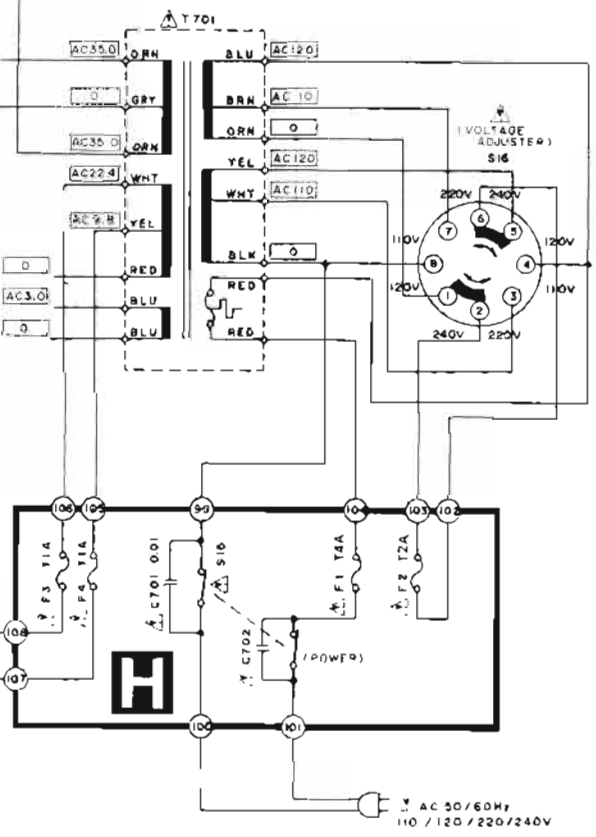
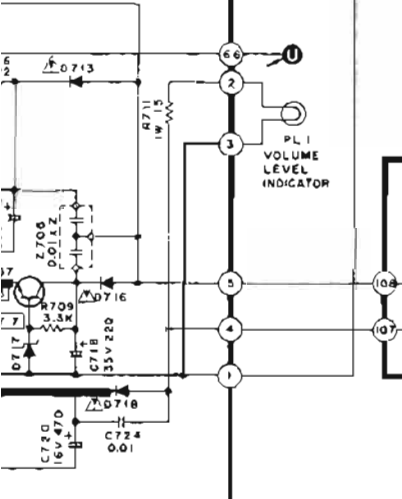
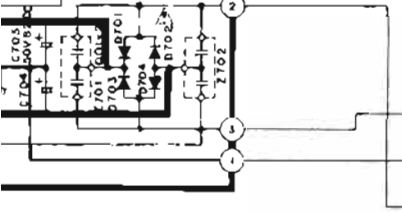

■ POWER SOURCE CIRCUIT OF OTHER PRODUCTS

● Product for Australia [XAL] only

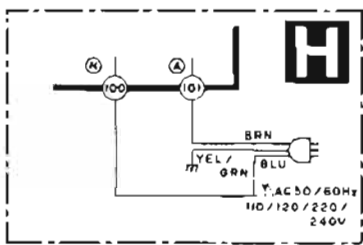

● Product for Asia, Latin America, Middle East and Africa [XA]

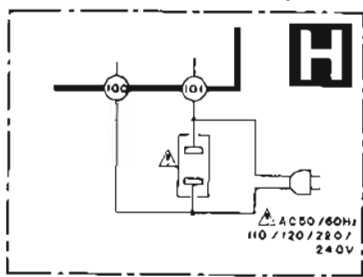

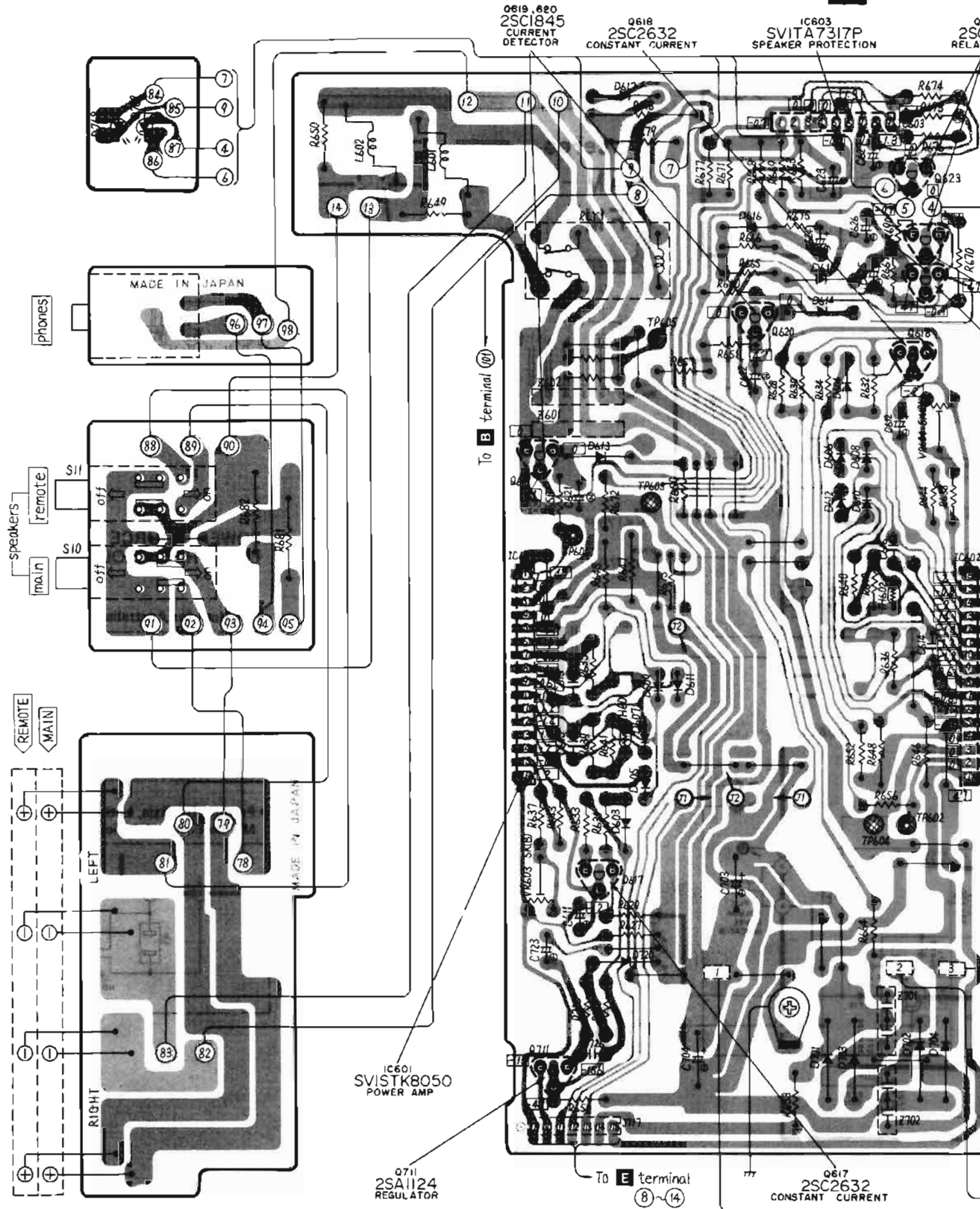



(Earth) lines

**F** Main amp & power source circuit

**H** Power source circuit

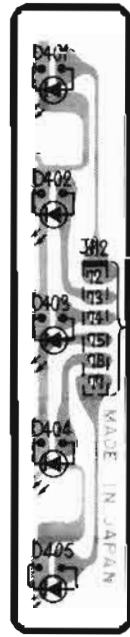
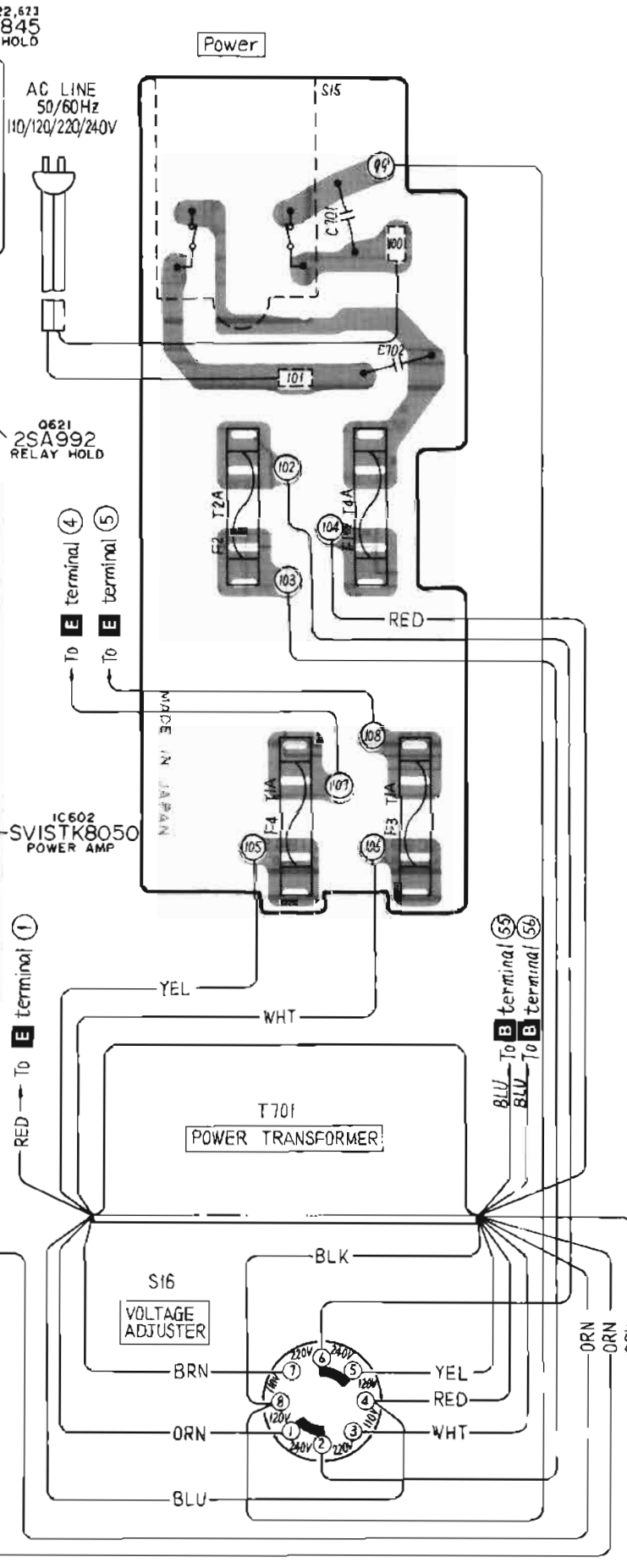
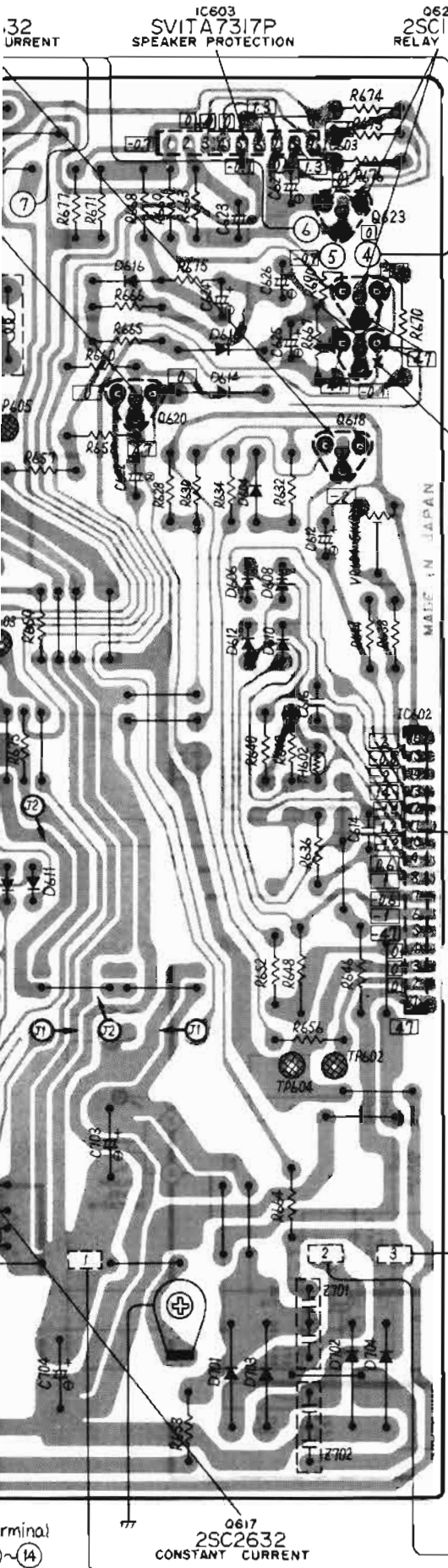

- To A terminal ⑥, ⑦
- To A terminal ⑬, ⑭
- To A terminal ⑧, ⑨
- To A terminal ④④~④⑤

- To A terminal ①~③
- | IC401,402 SVITA7322P EQUALIZER AMP |       |  |
|------------------------------------|-------|--|
| 1                                  | —     |  |
| 2                                  | 0.1   |  |
| 3                                  | 0.1   |  |
| 4                                  | -13.7 |  |
| 5                                  | 15    |  |
| 6                                  | —     |  |
| 7                                  | 0     |  |
| 8                                  | -10   |  |
| 9                                  | 15.7  |  |

**D** Equalizer & volume control circuit.

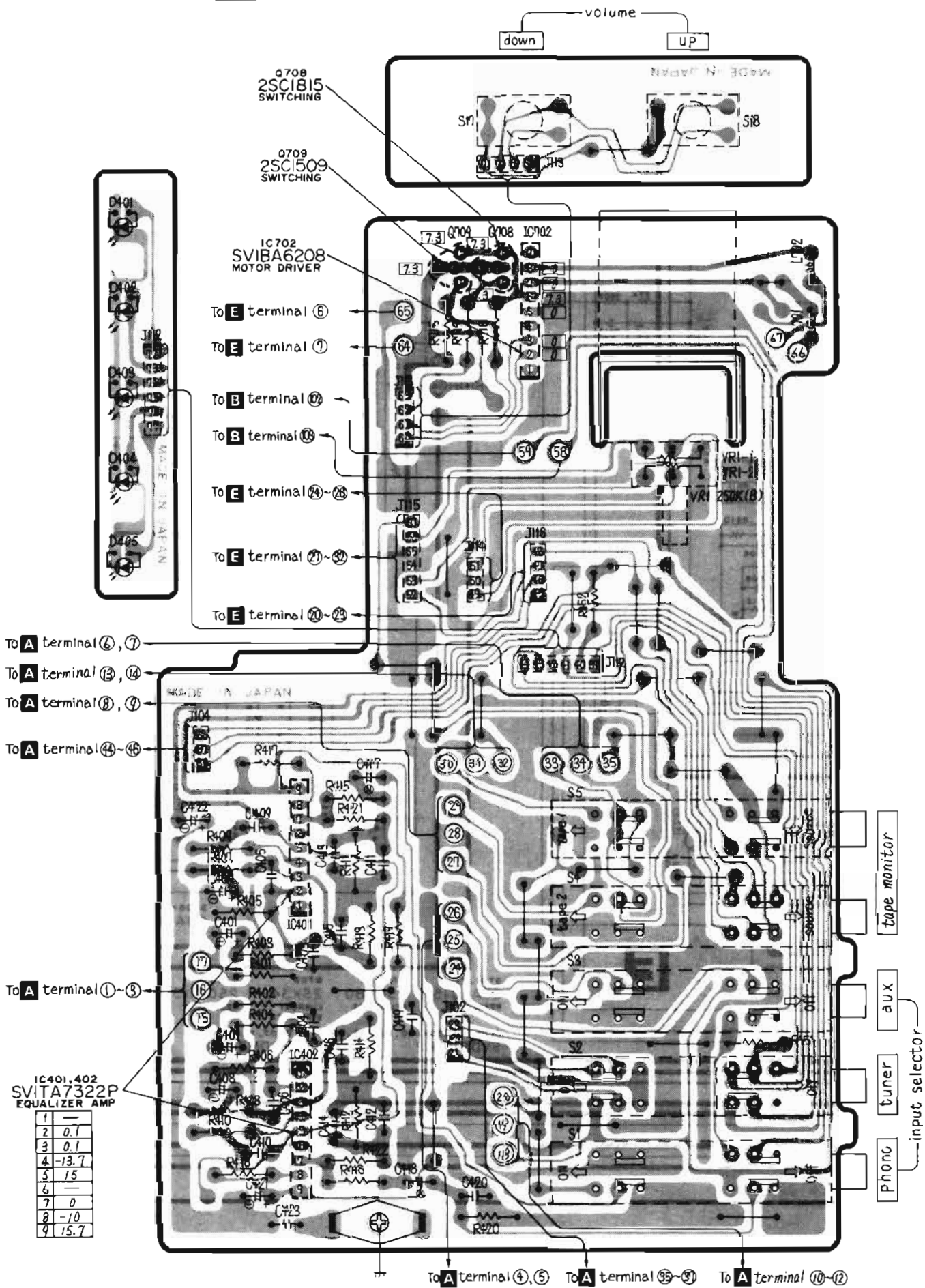



■ LOCATION OF P.C.B.

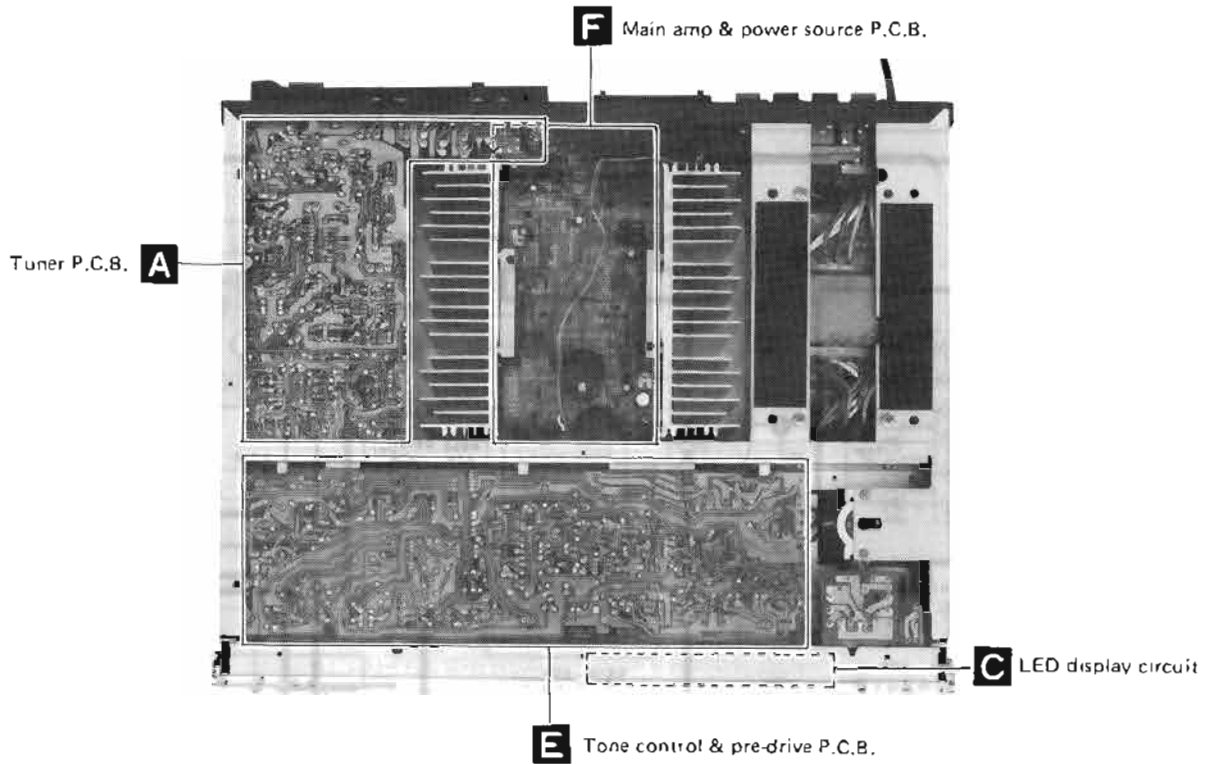
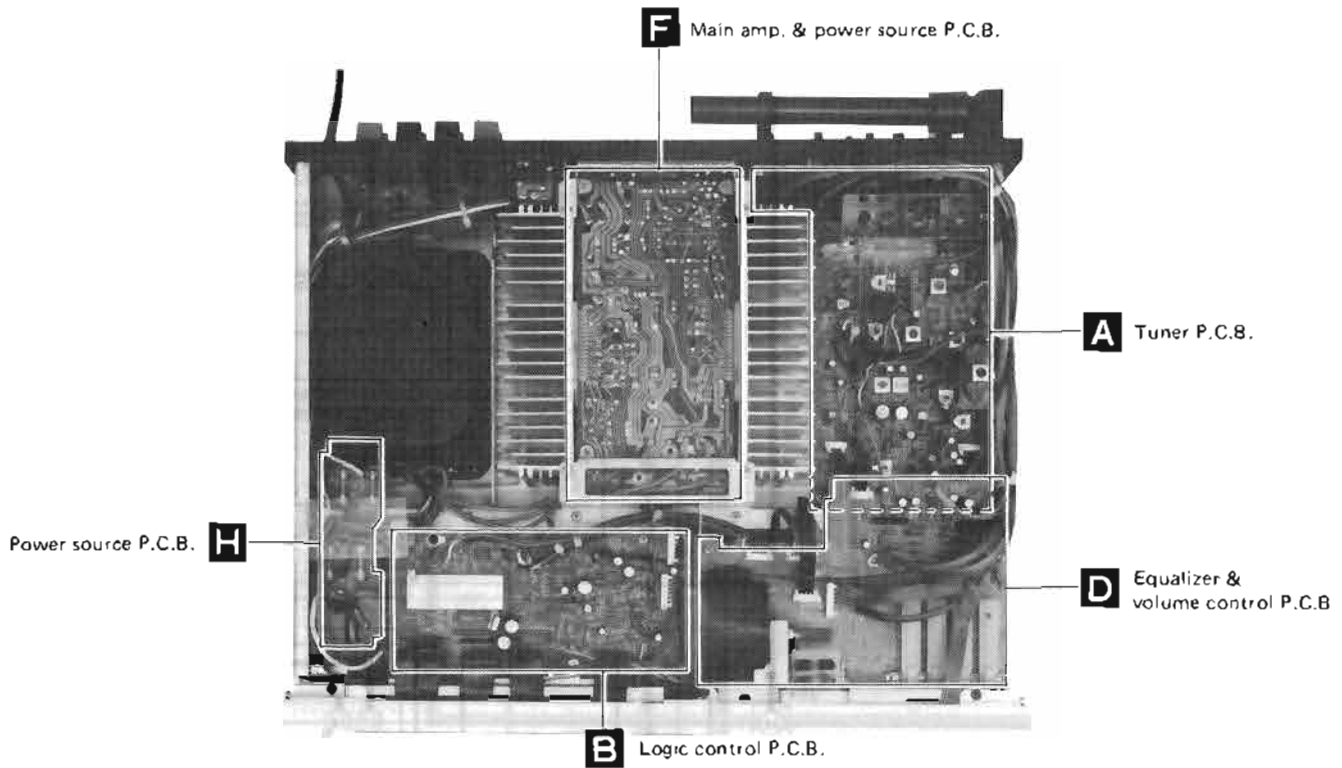

Bottom view

**TERMINAL GUIDE OF TRANSISTORS & IC'S**

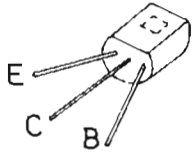
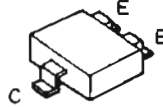
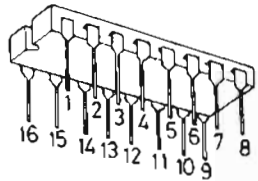
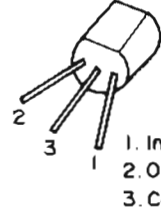
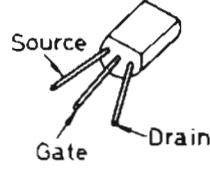
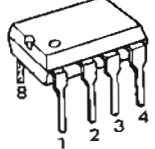
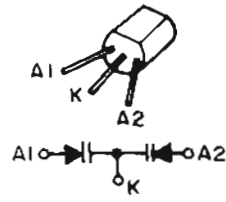
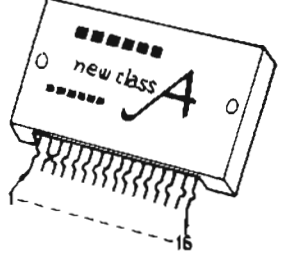
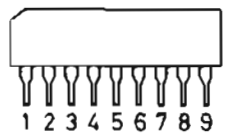
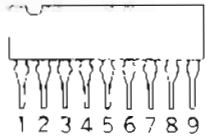
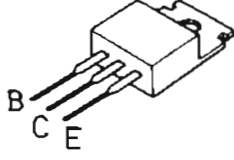
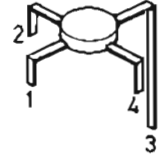
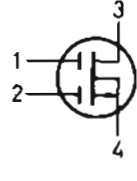
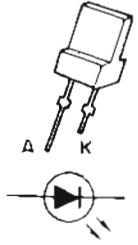
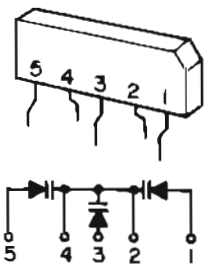
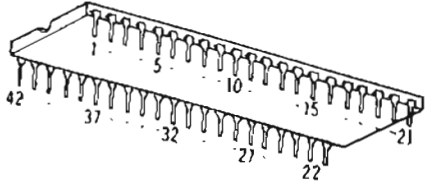
2SC2320L, 2SC1815, 2SA666A1, 2SA1015, 2SA1124, 2SC1684, 2SA1123, 2SC2631, 2SC1845, 2SC2632, 2SC1509	2SC2295, 2SC2404, 2SB709, 2SD601, 2SC2778, 2SD601, 2SD601A, 2SB709A	SV $\mu$ PC1167C2, AN217PBB, AN363N, SVITC50678P, SVIM74LS42P	SVITA78L006A
			
2SK34-D1	AN6552, AN6552F, SV $\mu$ PB553C-E	SVDBB204	SVISTK8050
			
SVITA7322P, SVITA7317P	SVIBA6208	2SD880, 2SD762	3SK74-L1
			
LN417YP, LN217RP	SVDBB113	SV $\mu$ PD1704CL	
			
LN417YP, LN217RP	SVDBB113	SV $\mu$ PD1704CL	SVDMZ□□□□

**Shorting Switch**

This unit uses a shorting switch. As illustrated below, the circuit is shorted to the next circuit without being opened. In the circuit diagram, the shaded area represents the common terminal.

