

Service Manual

AV Control Stereo Receiver



Receiver

SA-AX6

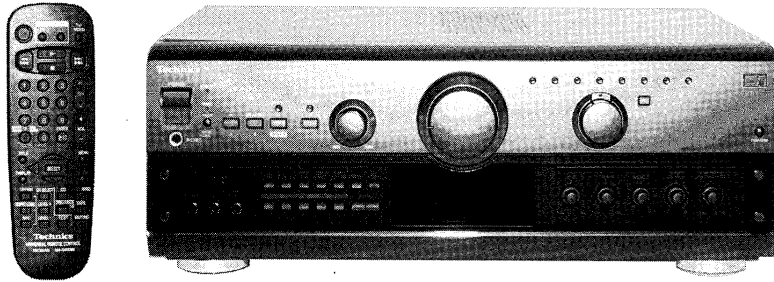

Colour

(K) Black Type

Area

| Suffix for Model No. | Area | Colour |
|----------------------|-----------------|--------|
| (PP) | U.S.A. & Canada | (K) |

Manufactured under license from Dolby Laboratories Licensing Corporation. DOLBY, the double-D symbol and "PRO LOGIC" are trademarks of Dolby Laboratories Licensing Corporation.

Specifications

Amplifier Section

Rated minimum sine wave RMS power output
 20 Hz-20 kHz both channels driven
 0.05% total harmonic distortion 100 W per channel (6Ω)
1 kHz continuous power output both channels driven
 0.05% total harmonic distortion 105 W per channel (6Ω)
Total harmonic distortion
 Rated power at 20 Hz – 20 kHz 0.05 % (6Ω)
 Half power at 1 kHz 0.03 % (6Ω)
Power output at the DVD 6CH operation
 20 Hz-20 kHz (each channels driven)
 0.09% total harmonic distortion
 Front 2 X 100 W (6Ω)
 Center 100 W (6Ω)
 Surround 2 X 100 W (6Ω)
 Subwoofer 100 W (6Ω)
Low frequency damping factor 30 (6Ω)
Load impedance
 Front A or B 4 - 8 Ω
 A and B 8 Ω
 BI-WIRE 6 - 8 Ω
 Center 6 - 8 Ω
 Surround 6 - 8 Ω
 Subwoofer 6 - 8 Ω
Dynamic headroom 2 dB (8 Ω)
Frequency response
 PHONO RIAA standard curve (30 Hz-15 kHz) ± 0.8 dB
 CD, TAPE, DVD, VCR 1, TV/DSS/VCR 2, VCR 3 10 Hz – 70 kHz, ± 3 dB
Input sensitivity
 PHONO 0.4 mV (3 mV, IHF ' 66)
 CD, TAPE, DVD, VCR 1, TV/DSS/VCR 2, VCR 3 27 mV (200 mV, IHF ' 66)
S/N (IHF A)
 PHONO 70 dB (80 dB, IHF ' 66)

CD, TAPE, DVD, VCR 1, TV/DSS/VCR 2, VCR 3

75 dB (85 dB, IHF ' 66)

Input impedance

PHONO 47 kΩ

CD, TAPE, DVD, VCR 1, TV/DSS/VCR 2, VCR 3 22 kΩ

Tone controls

BASS 50 Hz, +10 to -10 dB

TREBLE 20 kHz, +10 to -10 dB

Adaptive control (volume at -30 dB) 50 Hz, +9 dB

Subwoofer cut off frequency control 50 – 200 Hz

FM Tuner Section

Frequency range 87.9 — 107.9 MHz

Sensitivity 11.2 dBf (2 μV, IHF '58)

50 dB quieting sensitivity

MONO 18.3 dBf (4.5 μV, IHF '58)

STEREO 38.3 dBf (45 μV, IHF '58)

Total harmonic distortion

MONO 0.2 %

STEREO 0.3 %

S/N

MONO 73 dB

STEREO 67 dB

Frequency response 20 Hz — 15 kHz (+1 dB, -2 dB)

Alternate channel selectivity 65 dB

Capture ratio 1.5 dB

Image rejection at 98 MHz 40 dB

Spurious response rejection at 98 MHz 75 dB

AM suppression 50 dB

Stereo separation

1 kHz 40 dB

10 kHz 30 dB

Antenna terminal 75 Ω (unbalanced)

WARNING

This service information is designed for experienced repair technicians only and is not designed for use by the general public. It does not contain warnings or cautions to advise non-technical individuals of potential dangers in attempting to service a product. Products powered by electricity should be serviced or repaired only by experienced professional technicians. Any attempt to service or repair the product or products dealt with in this service information by anyone else could result in serious injury or death.

Technics®

© 1998 Matsushita Electronics (S) Pte. Ltd.
 All rights reserved. Unauthorized copying and distribution is a violation of law.

Connections

Make sure that the power supply for all components has been turned off before making any connections.

Refer to the operating instructions of the equipment to be connected.

Note

Do not place books, etc., on the top of this unit or block the heat radiation vents in any way.

Connecting audio equipment

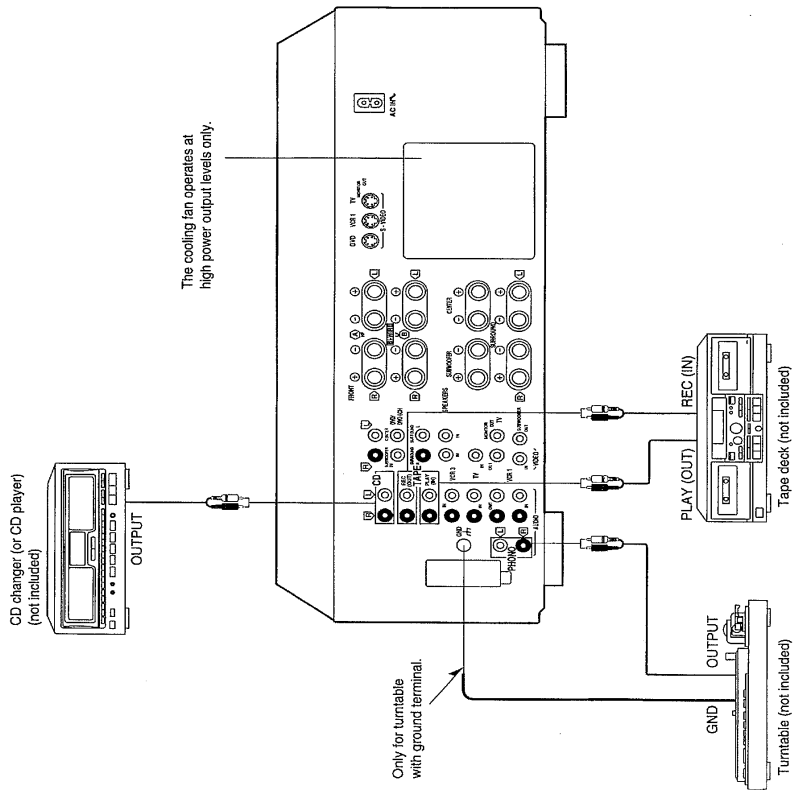
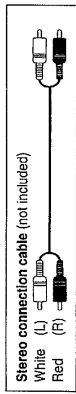

Connecting video equipment

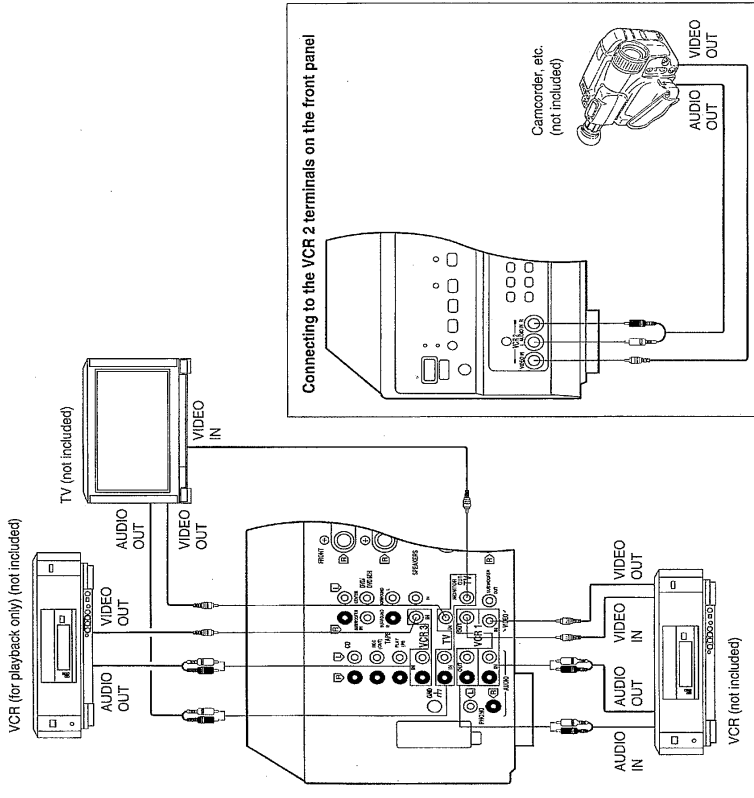
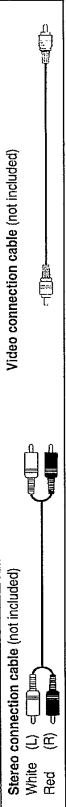

To connect video equipment with a 21 pin terminal

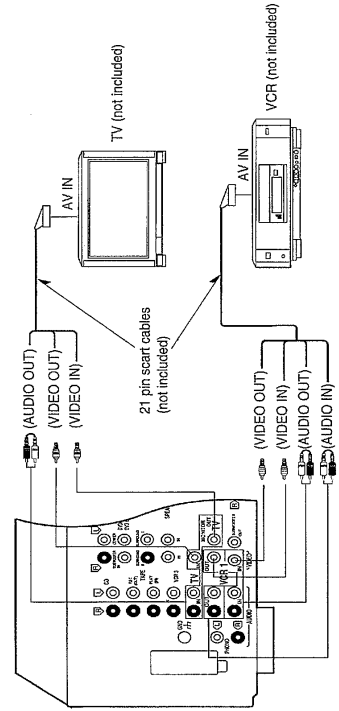

Connecting a DVD player

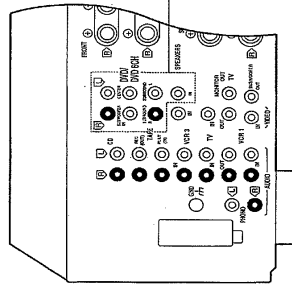
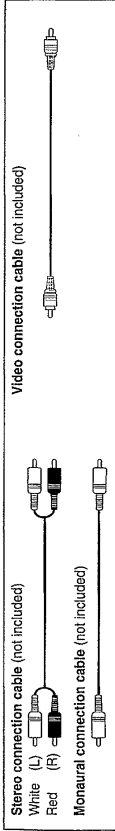

Connecting a DVD player with 6 channel discrete output

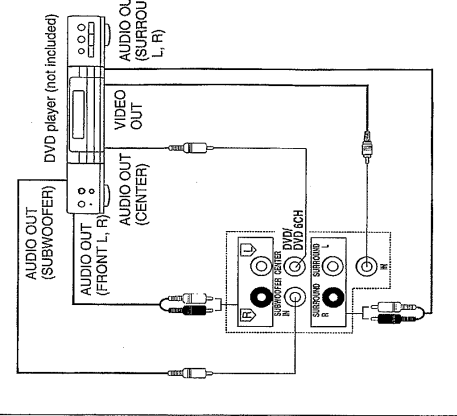

Note
If you want to connect a DVD player with DISCRETE 6CH output using only 2 channels, make the connection through the DVD player's MIXED AUDIO OUT terminals and this unit's DVD/DVD 6CH L and R terminals.
Do not connect any cables to this unit's DVD/DVD 6CH CENTER, SUBWOOFER IN, or SURROUND L and R terminals.

Connecting a DVD player with 2 channel output

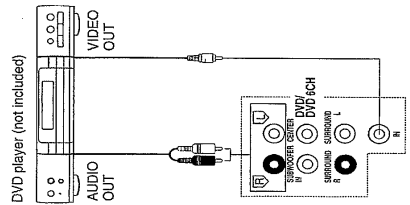

You can enjoy 6 channel discrete sound by making the below connections.

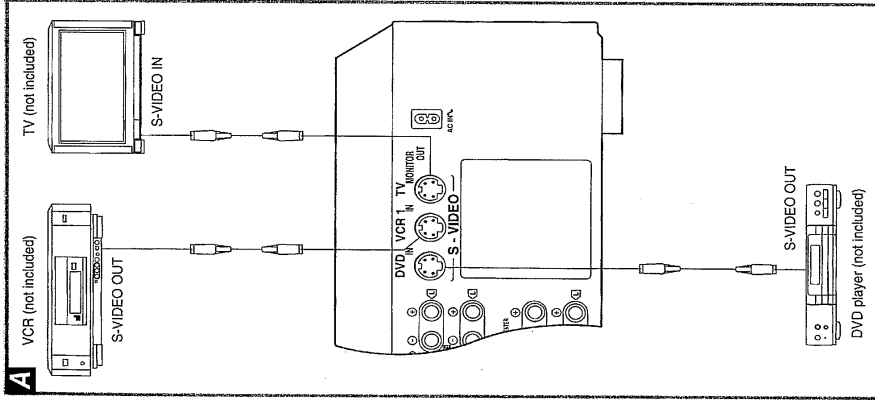
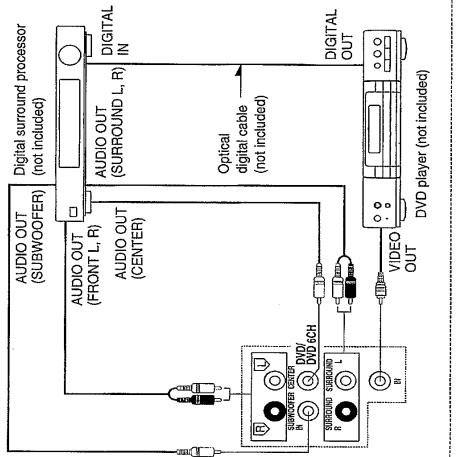

Connections to/from S-VIDEO terminals

S-VIDEO cable (not included)
This receiver has an S-VIDEO terminal for a DVD player, VCR (VCR 1 only) and TV.

Caution when using a TV with an S-VIDEO terminal

On some television models, the video signal from components which do not use S-VIDEO input and are connected only to the VIDEO terminals will not be shown on the television screen. If this occurs, use one of the following methods to view the video signal.

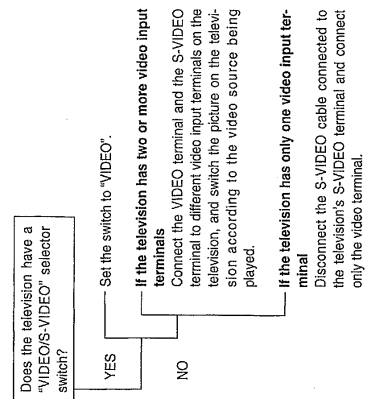

Note
When using S-VIDEO terminals be aware of the following. Video signals input into the VIDEO terminals cannot be output from S-VIDEO terminals or vice versa.

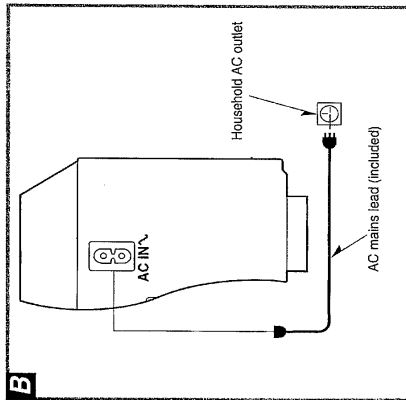

AC mains lead

Connect this mains lead after all other cables and cords are connected.

BE SURE TO READ THE CAUTION FOR THE AC MAINS LEAD ON PAGE 3 BEFORE THE FOLLOWING CONNECTION.

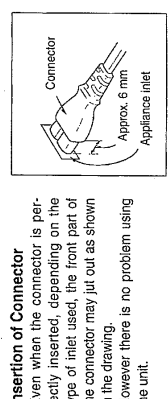

Insertion of Connector
Even when the connector is perfectly inserted, depending on the type of inlet used, the front part of the connector may jut out as shown in the drawing.
However, there is no problem using the unit.

Center speaker

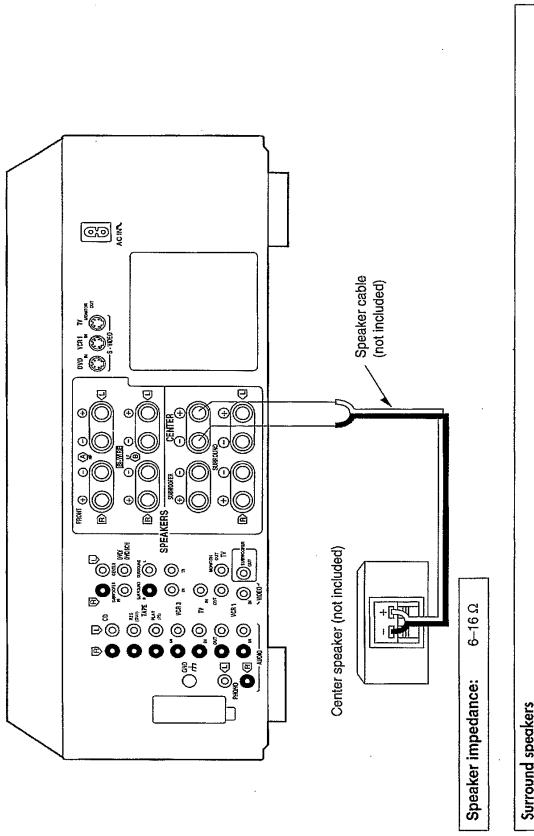

Note

1. Both surround speakers must be connected before sound can be heard from them.
2. Do not connect the surround speakers to the front speaker terminals, as they may be damaged.

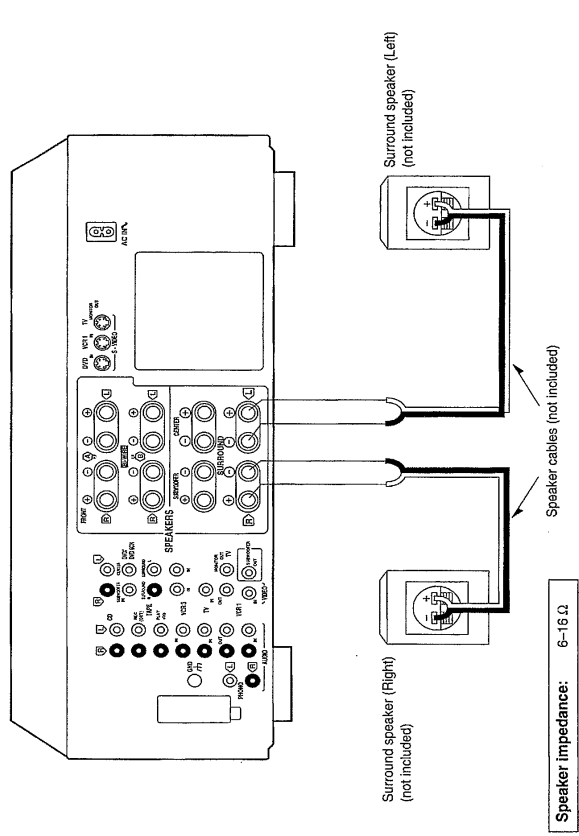

Speaker connections

To connect to the "A" terminals

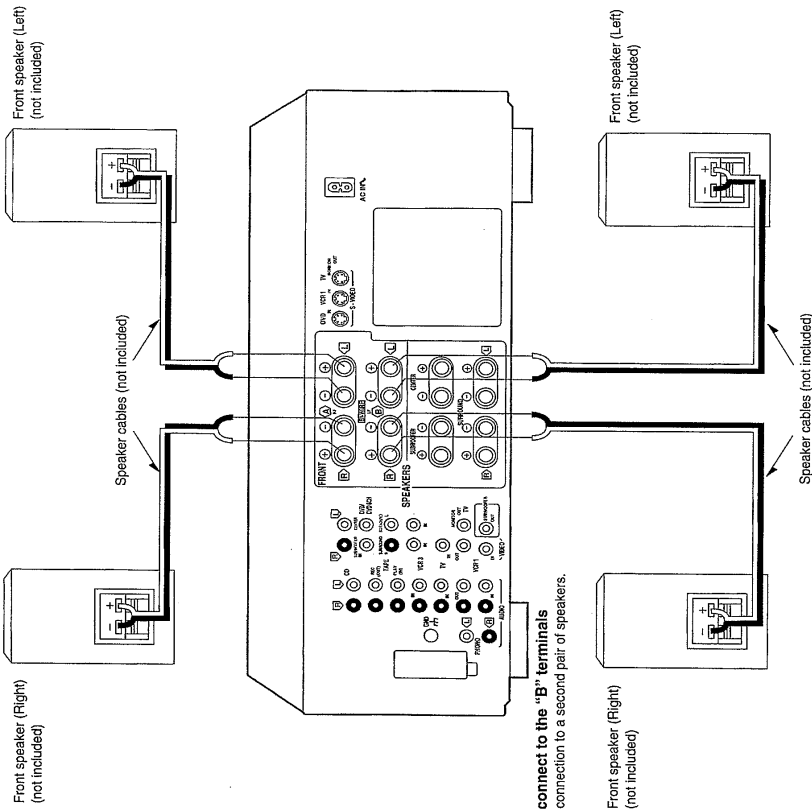

Speaker impedance: A or B: 4-16 Ω
A and B: 8-16 Ω
BI-WIRE: 6-16 Ω

Connecting the speaker cable



Note

To prevent damage to circuitry, never short-circuit positive (+) and negative (-) speaker wires.

Basic Operations

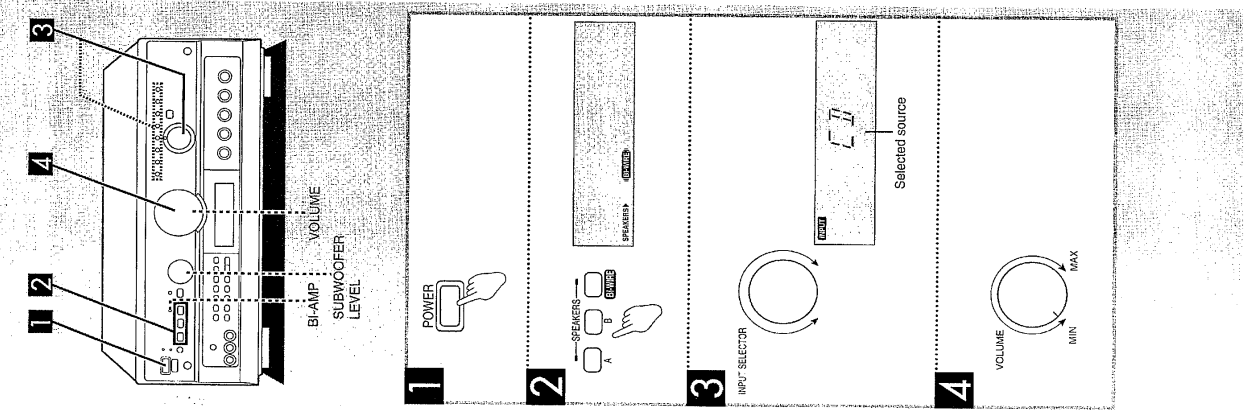

Before operation, set **VOLUME** to the "MIN" position.

A, B and **BAWIRE** refer to the speaker terminals at the rear of the unit. When **BAWIRE** is selected, the **BI-AMP** indicator will illuminate. If the button is pressed once more, the indicator will switch off and no sound will be heard from the speakers.

Note **BAWIRE** and **A**, or **BAWIRE** and **B** cannot both be used at the same time. The **BI-AMP** indicator goes out if a **Dolby Pro Logic** mode is turned on or if the **DVD 6CH INPUT** mode is selected.

Note The indicator which corresponds to the selected input source will illuminate. The selected source and "INPUT" will be shown on the display.

VCR 1: To watch video tapes (VCR 1)
VCR 2: To watch TV or video tapes (VCR 2)
VCR 3: To watch video tapes (VCR 3)
DVD: To watch DVD
TAPE: To listen to cassette tapes
CD: To listen to compact discs
TUNER: To listen to radio broadcasts
PHONO: To listen to phono discs

If a Dolby Pro Logic mode has been selected
 After displaying the selected source, the display will then change to show the **Dolby Pro Logic** mode and "INPUT" will go out. If the source chosen was **TUNER** then the display will change again to show the frequency.

Note To watch a video (or DVD) or the TV, set the TV to either the TV mode or VIDEO mode.

For your reference
 If you are using **VCR** and you select **TAPE**, **CD**, **TUNER**, or **PHONO**, the picture will remain on the screen.

If using a subwoofer, adjust its volume with **SUBWOOFER LEVEL**. If the subwoofer isn't being used, be sure to set **SUBWOOFER LEVEL** to **MIN**.

After listening is finished
 Be sure to reduce the volume level, and switch the power to the standby condition by pressing **POWER**.

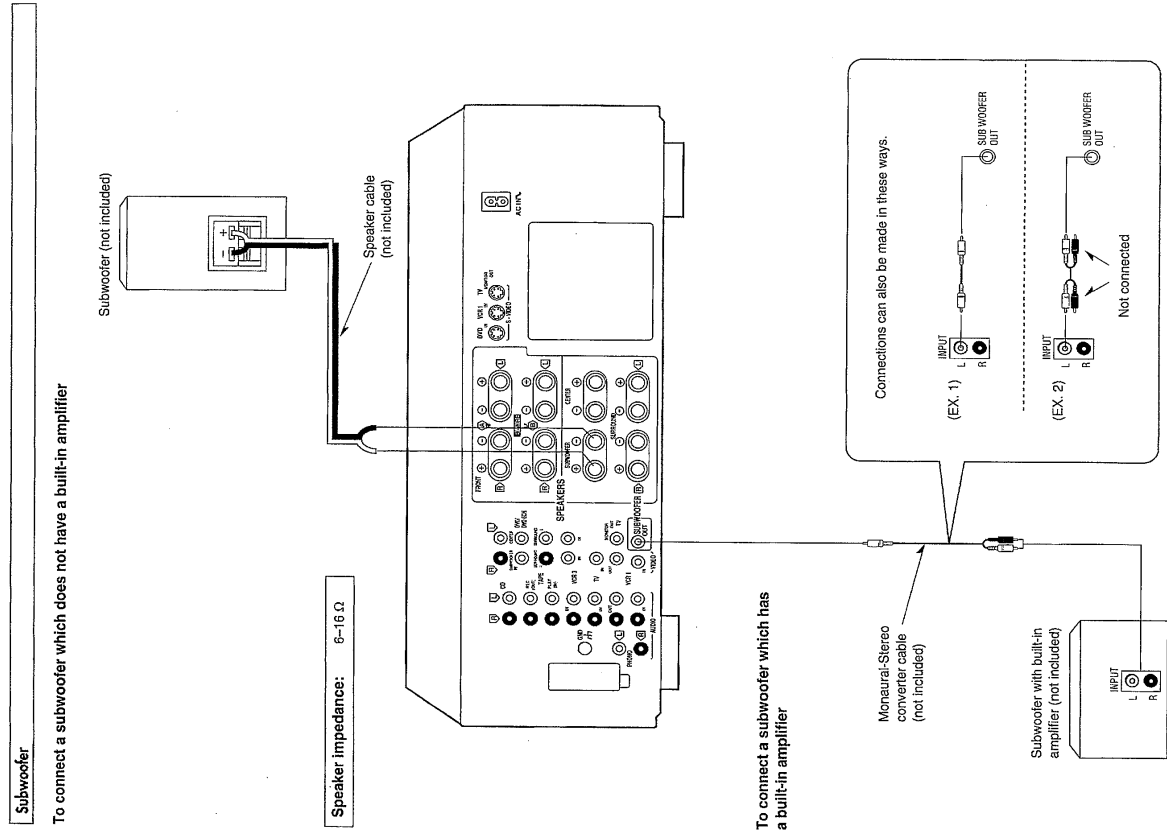

Terminal Guide of ICs, Transistors and Diodes

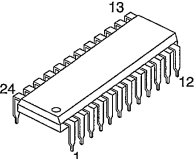
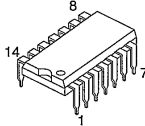
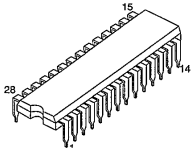
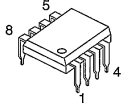
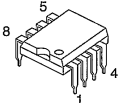
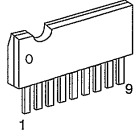
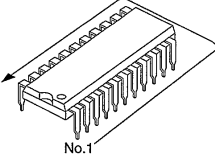
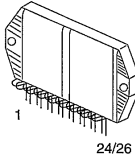
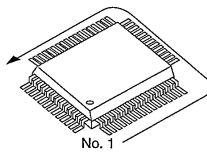
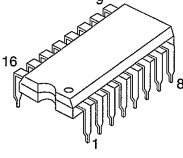
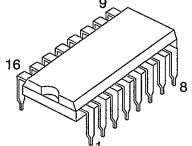
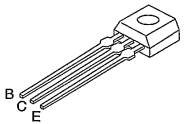
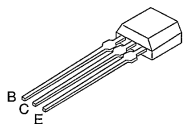
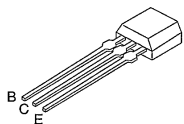
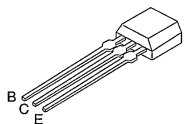
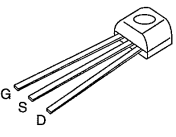
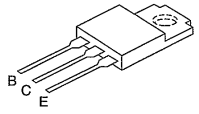
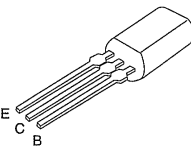
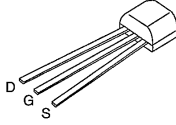
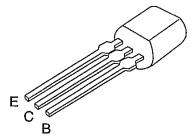
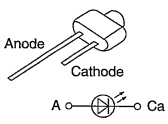
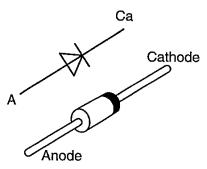
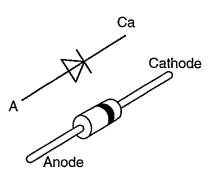
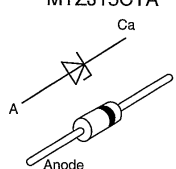
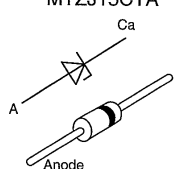
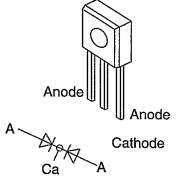
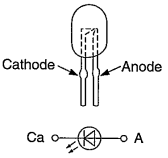
| | | | | |
|---|---|--|--|---|
| <p>LA1832A LC7218 LV1016L</p>  | <p>NJM2279D NJM2060D NJM2296D</p>  | <p>TC9163AN TC9162AN</p>  | <p>NJM4580DD</p>  | <p>AN6558F UPC4570C</p>  |
| <p>BA6218</p>  | <p>LA2786L (42Pin)</p>  | <p>RSN310R36-P</p>  | <p>M38B57M6101F (80 Pin)</p>  | <p>TC9214P</p>  |
| <p>BU2090</p>  | <p>2SC2785FETA 2SC2786MTA</p>  | <p>2SC2787FL1TA 2SC2787LTA 2SD1915FTA 2SC3311ARTA</p>  | <p>2SS933SSTA 2SA933SQRSTA</p>  | <p>2SC1740SQSTA RVTDTA114EST RVTDTA113ZST RVTDTA143XST RVTDTA114YST RVTDTA143XST</p>  |
| <p>2SK544F-AC</p>  | <p>2SB1548PQAU 2SD2374PQAU</p>  | <p>2SC3940AQSTA 2SA1534AQRTA</p>  | <p>2SK381CTA 2SJ40CTA</p>  | <p>2SB621AQSTA</p>  |
| <p>SLR325MCT31 SLR325VCT31</p>  | <p>1N5402BM21 RK306LFU1</p>  | <p>RVD1SS133TA 1SR35200TB MA700ATA 1SS291TA MA167ATA</p>  | <p>MTZJ10CTA MTZJ11CTA MTZJ15CTA</p>  | <p>MTZJ30DTA MTZJ3R0BTA MTZJ3R9ATA MTZJ4R7BTA MTZJ5R1BTA MTZJ5R6BTA MTZJ6R2BTA MTZJ6R8BTA MTZJ7R5CTA MTZJ8R2CTA</p>  |
| <p>SVC211SPA-AL</p>  | <p>LNG995PFBOA1</p>  | | | |

A MAIN CIRCUIT
(P.C.Board on page 32)

— : +B Line ⇒ : Main Signal Line
 - - : -B Line ⇒ : FM/AM Signal Line

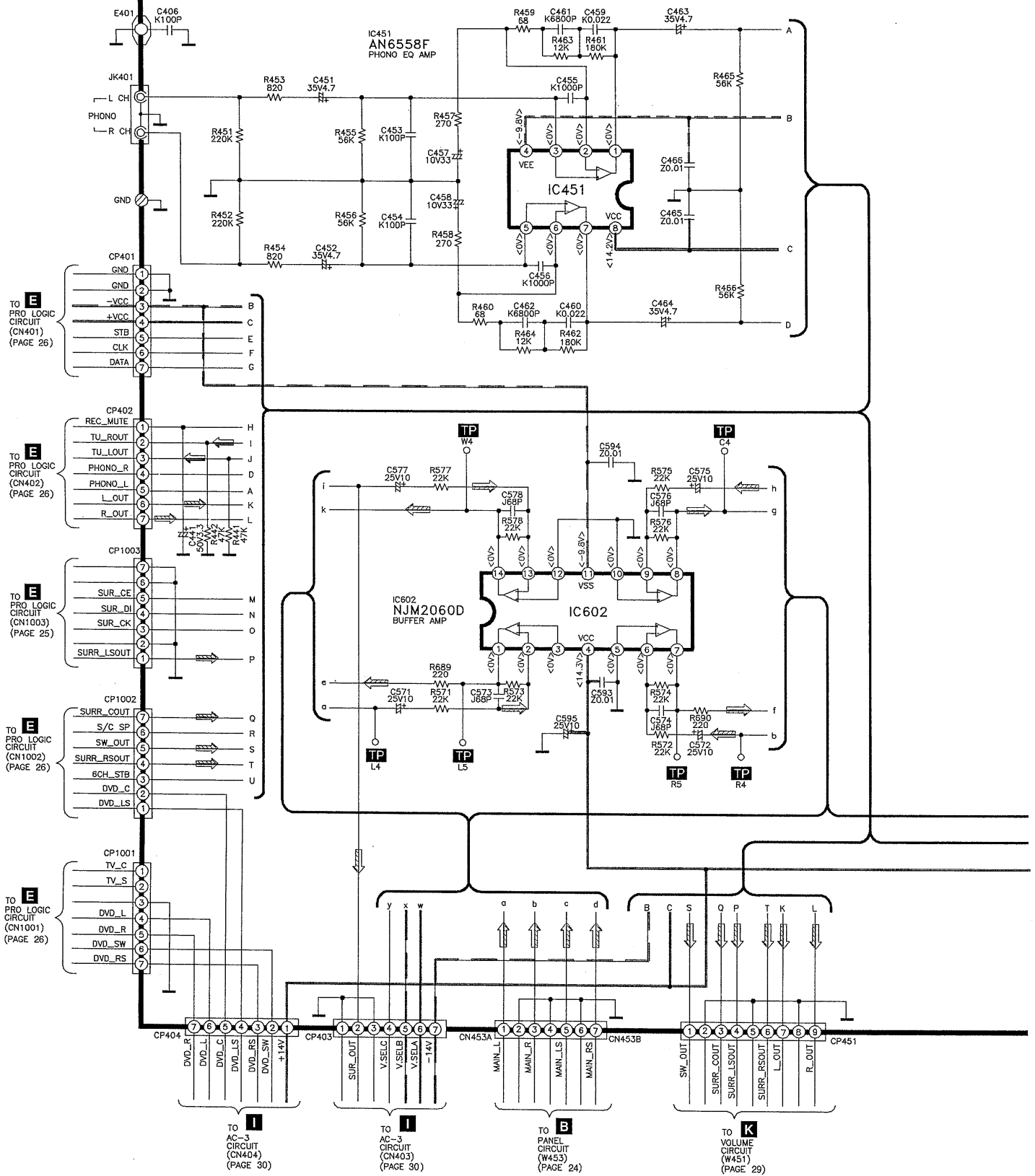

: +B Line
 : -B Line
 : Main Signal Line
 : FM/AM Signal Line

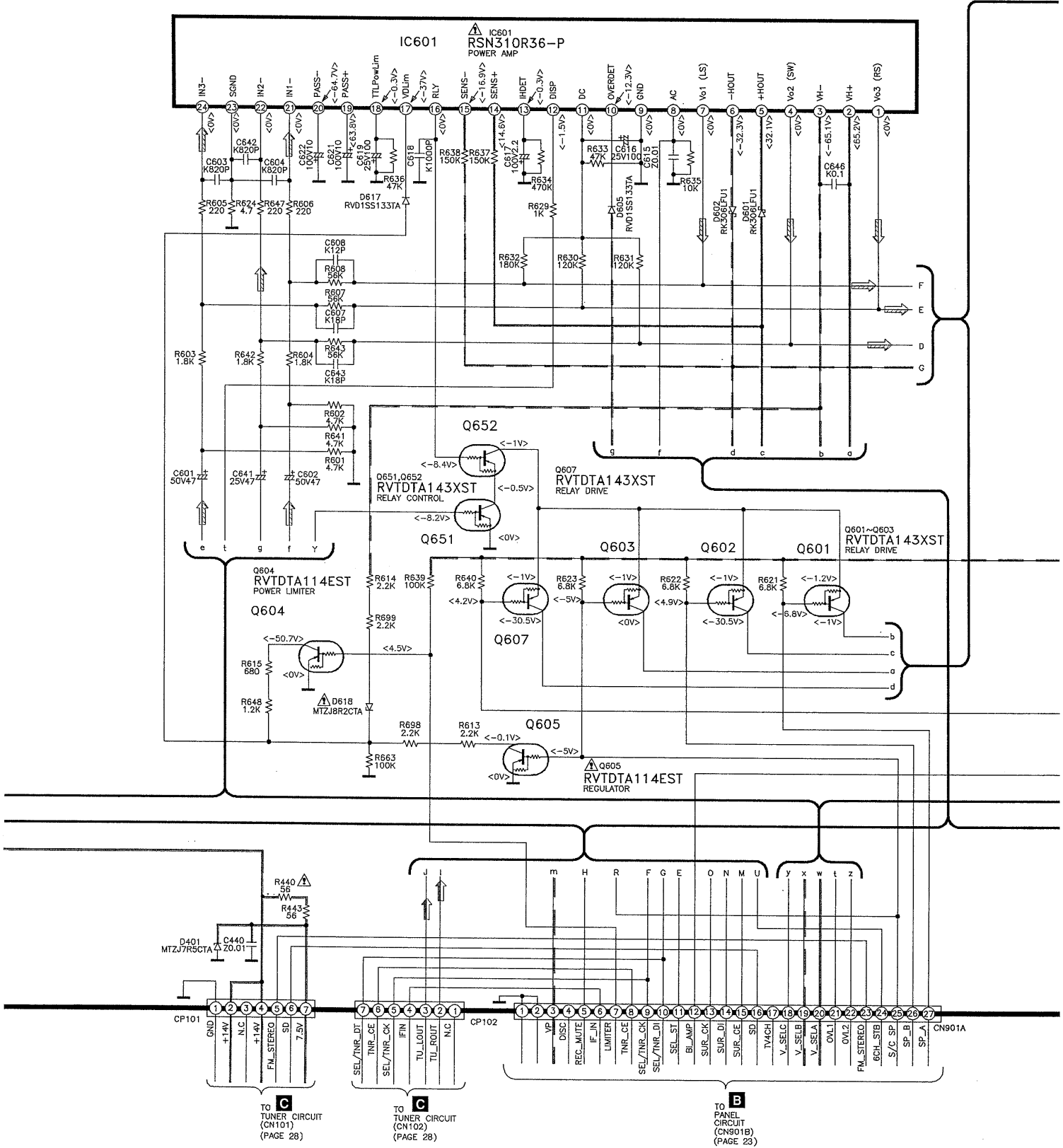

— : +B Line - - - : -B Line ⇨ : Main Signal Line

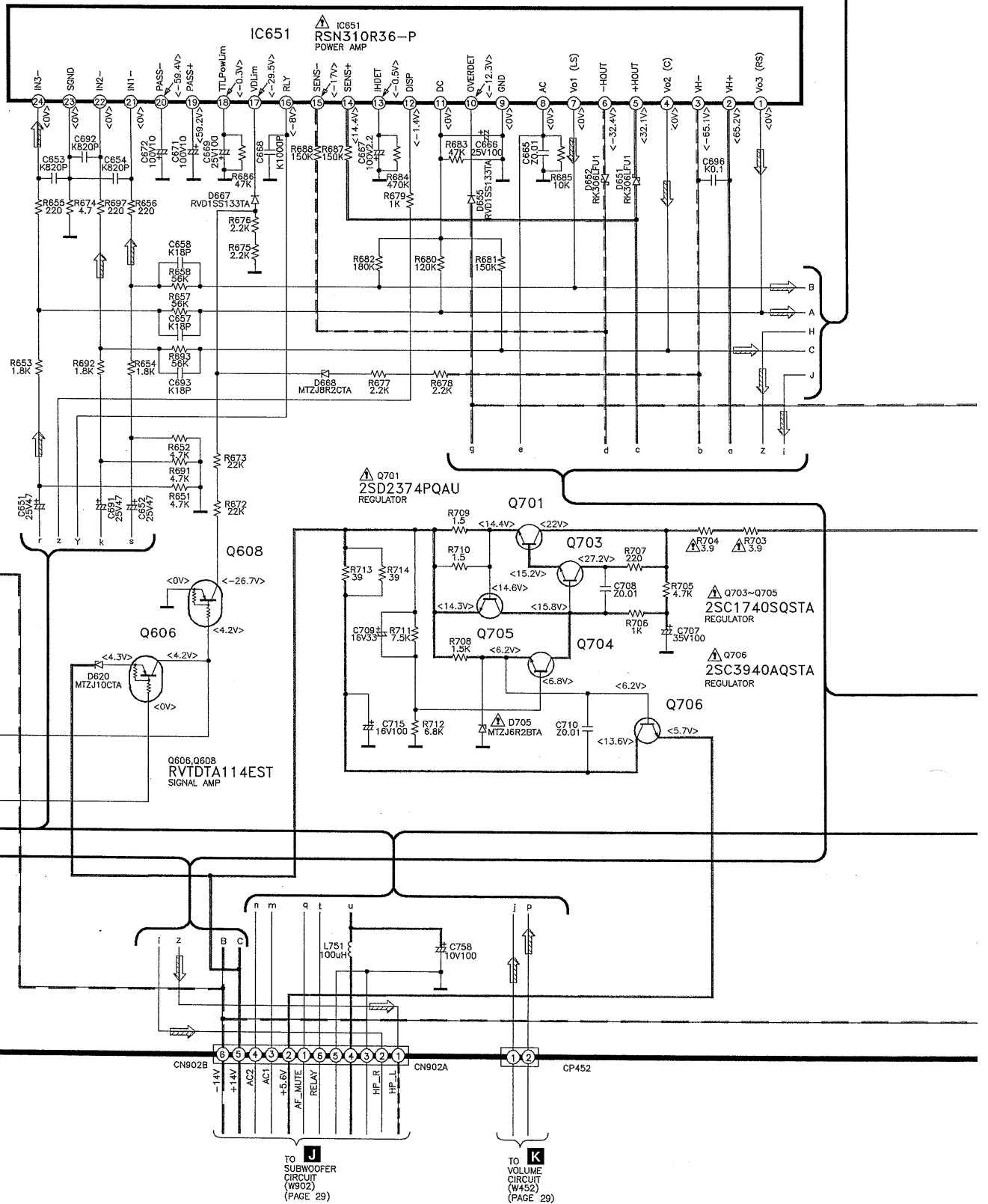

— : +B Line - - - : -B Line ⇨ : Main Signal Line

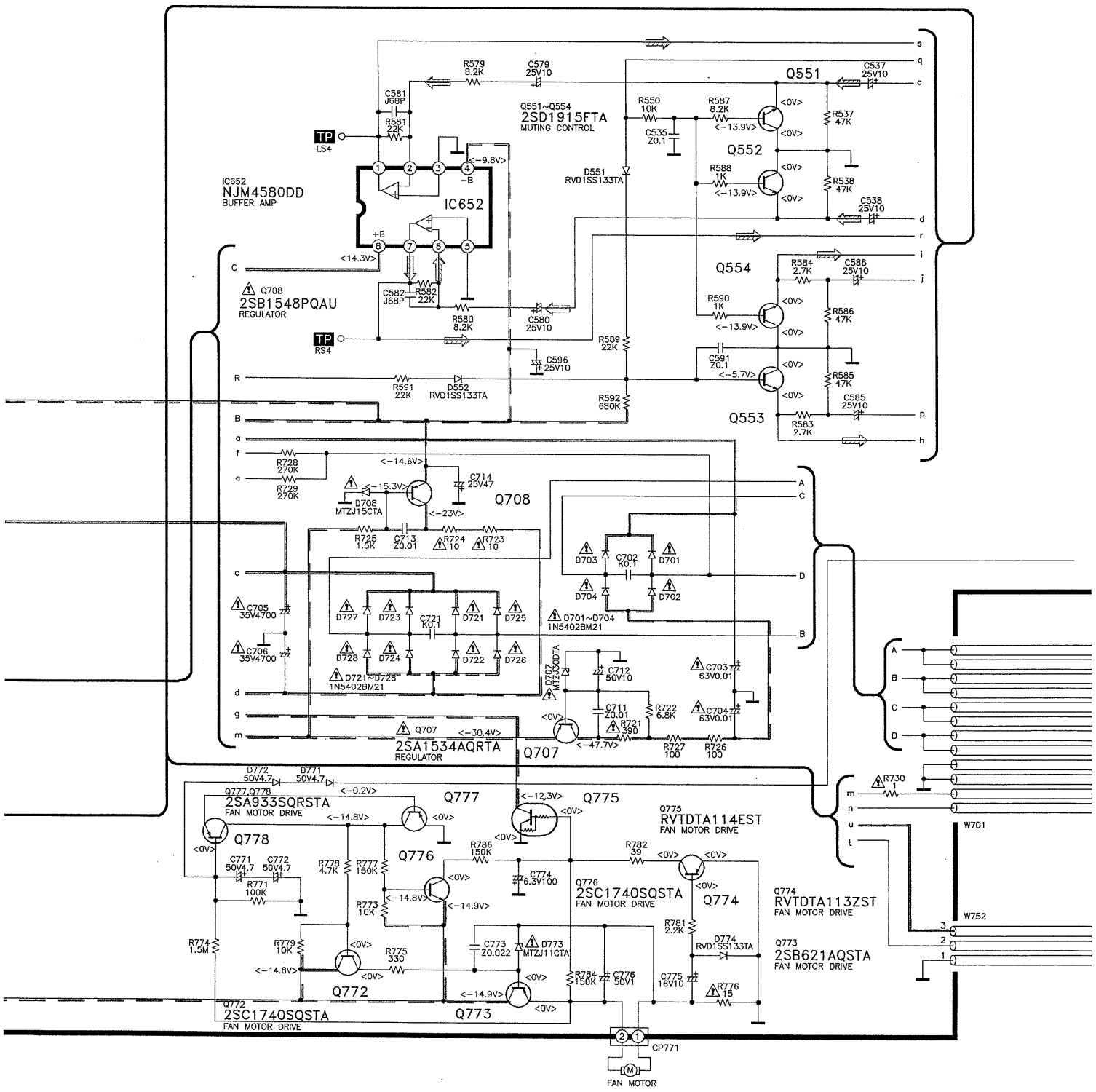

— : +B Line - - - : -B Line ⇨ : Main Signal Line

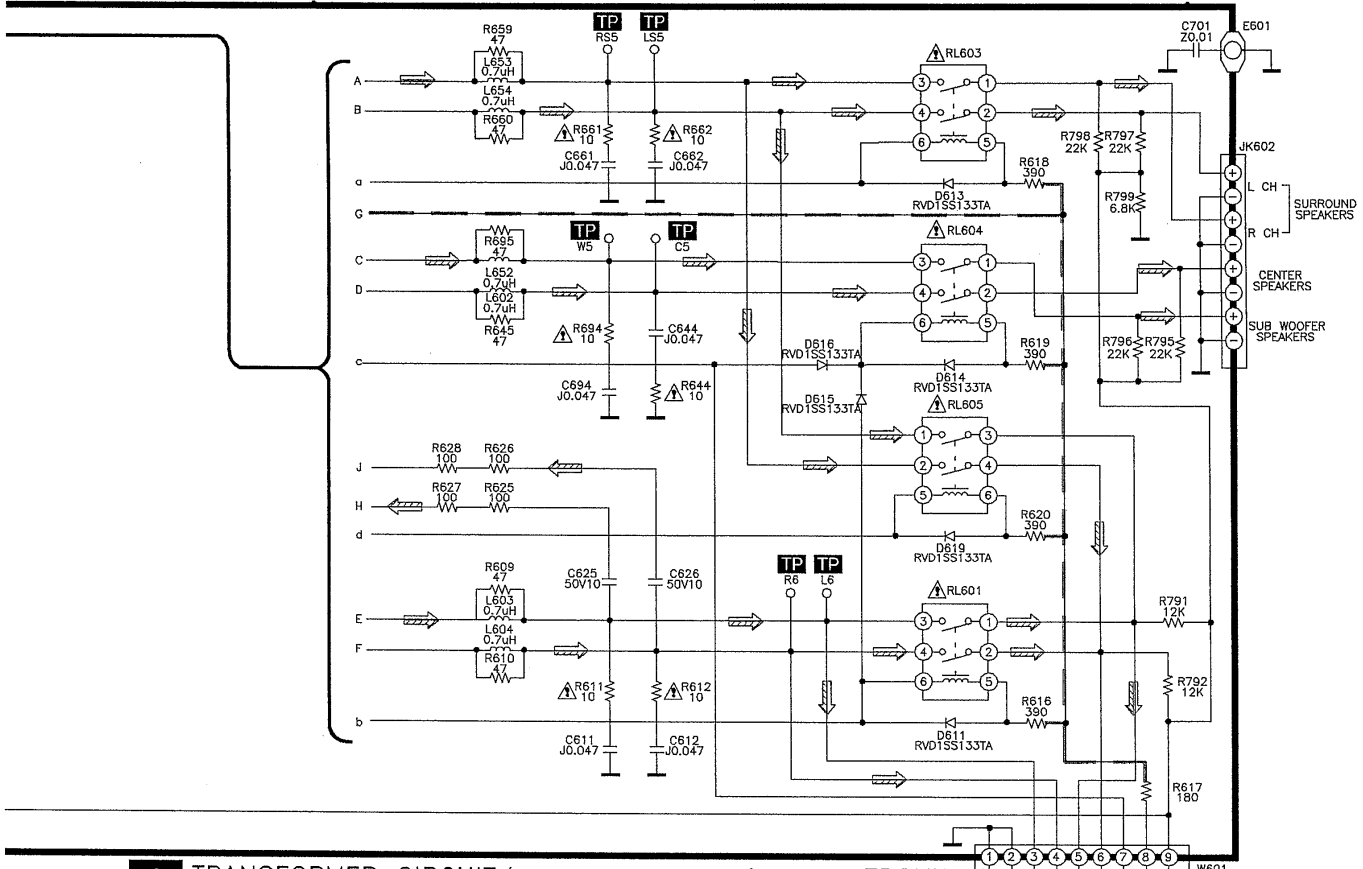

G TRANSFORMER CIRCUIT (P.C.Board on page 36)

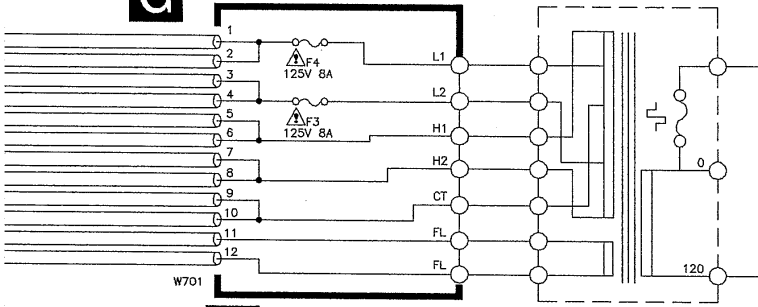

N FRONT SPEAKER CIRCUIT (P.C.Board on page 38)

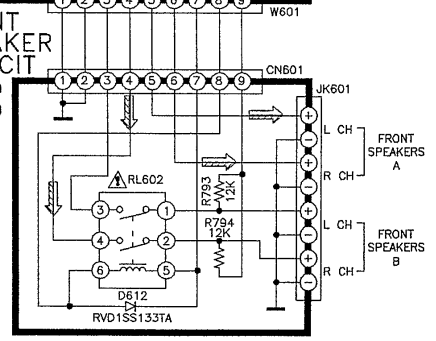

F POWER CIRCUIT (P.C.Board on page 36)

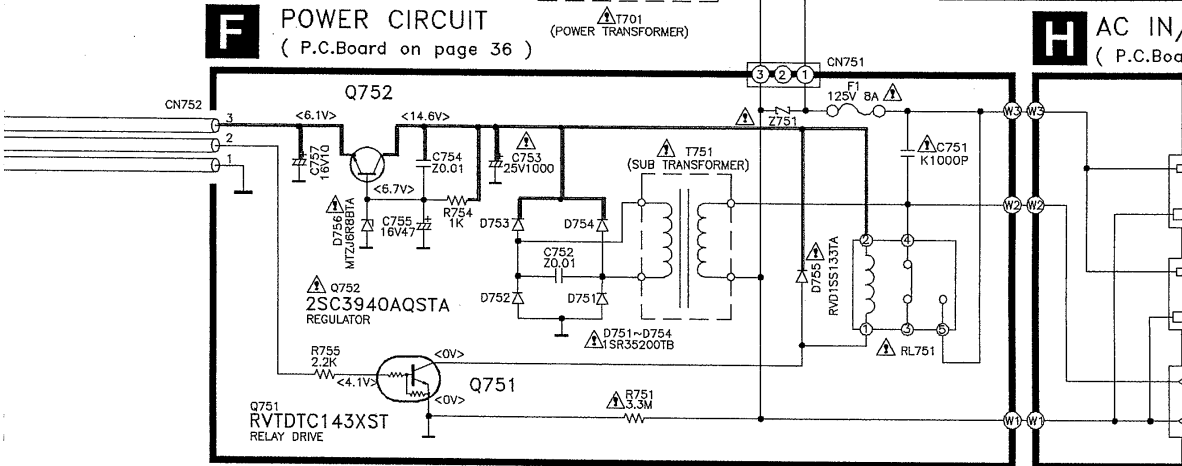

H AC IN/OUT CIRCUIT (P.C.Board on page 39)

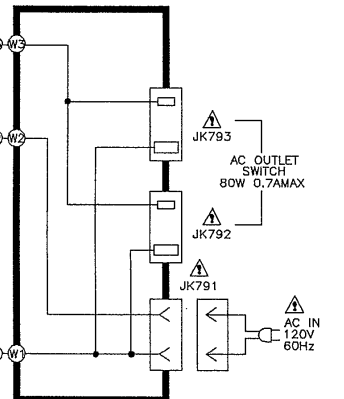

B PANEL CIRCUIT (P.C.BOARD ON PAGE 34)

— : +B Line - - - - : -B Line

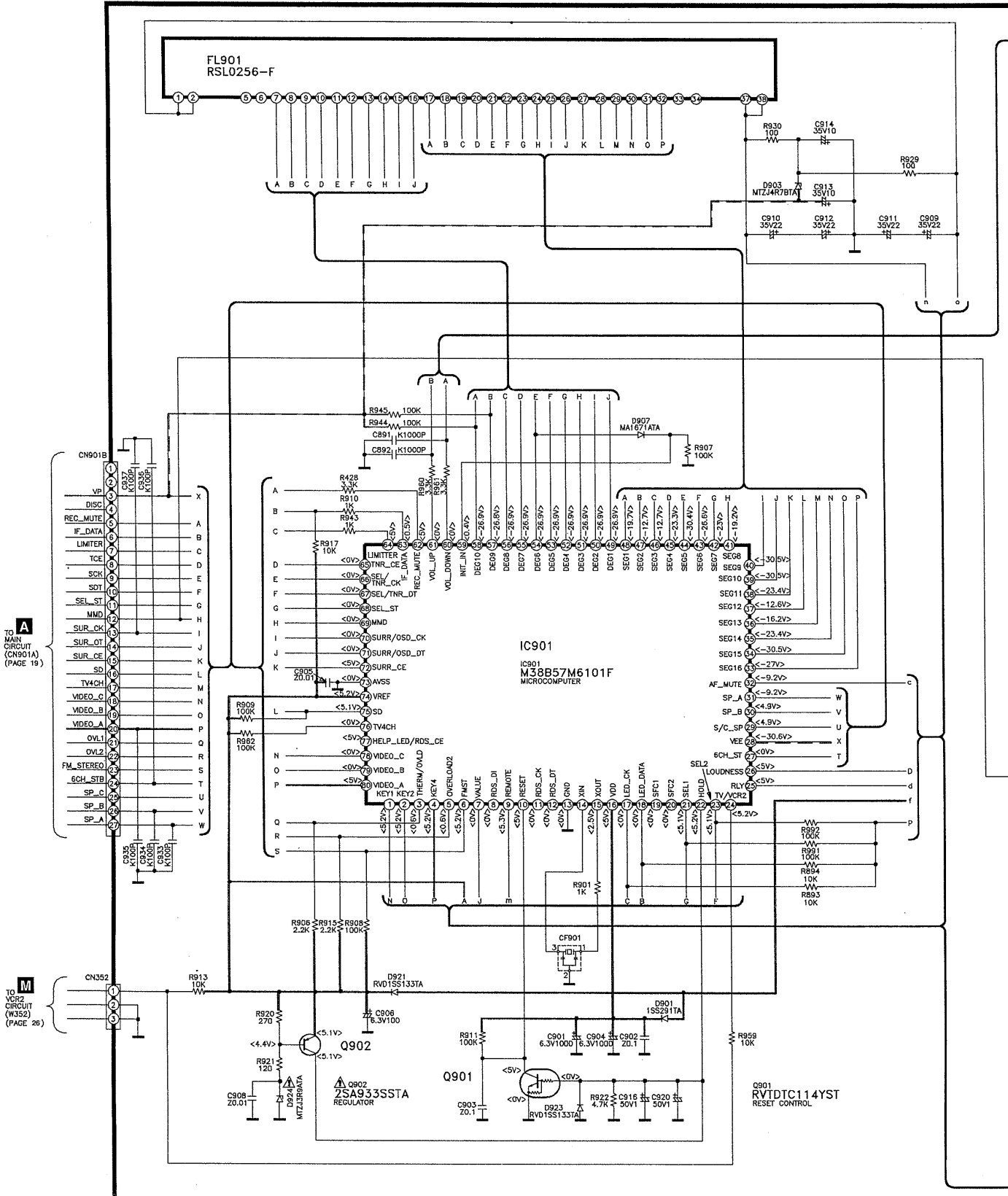

— : +B Line - - - : -B Line ⇨ : Main Signal Line

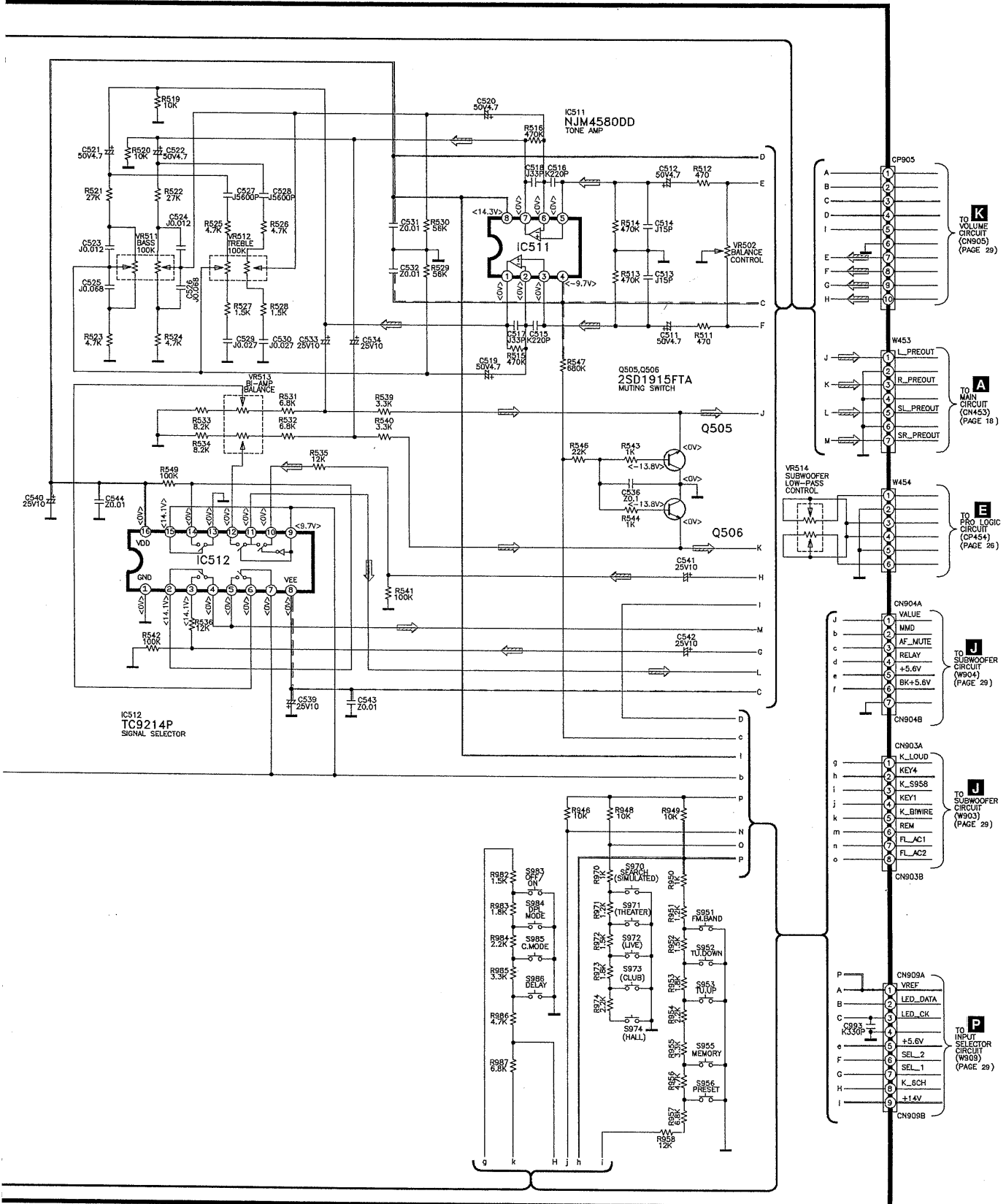

E PRO-LOGIC CIRCUIT (P.C.Board on page 31)

— : +B Line
- - - : -B Line
⇒ : Main Signal Line

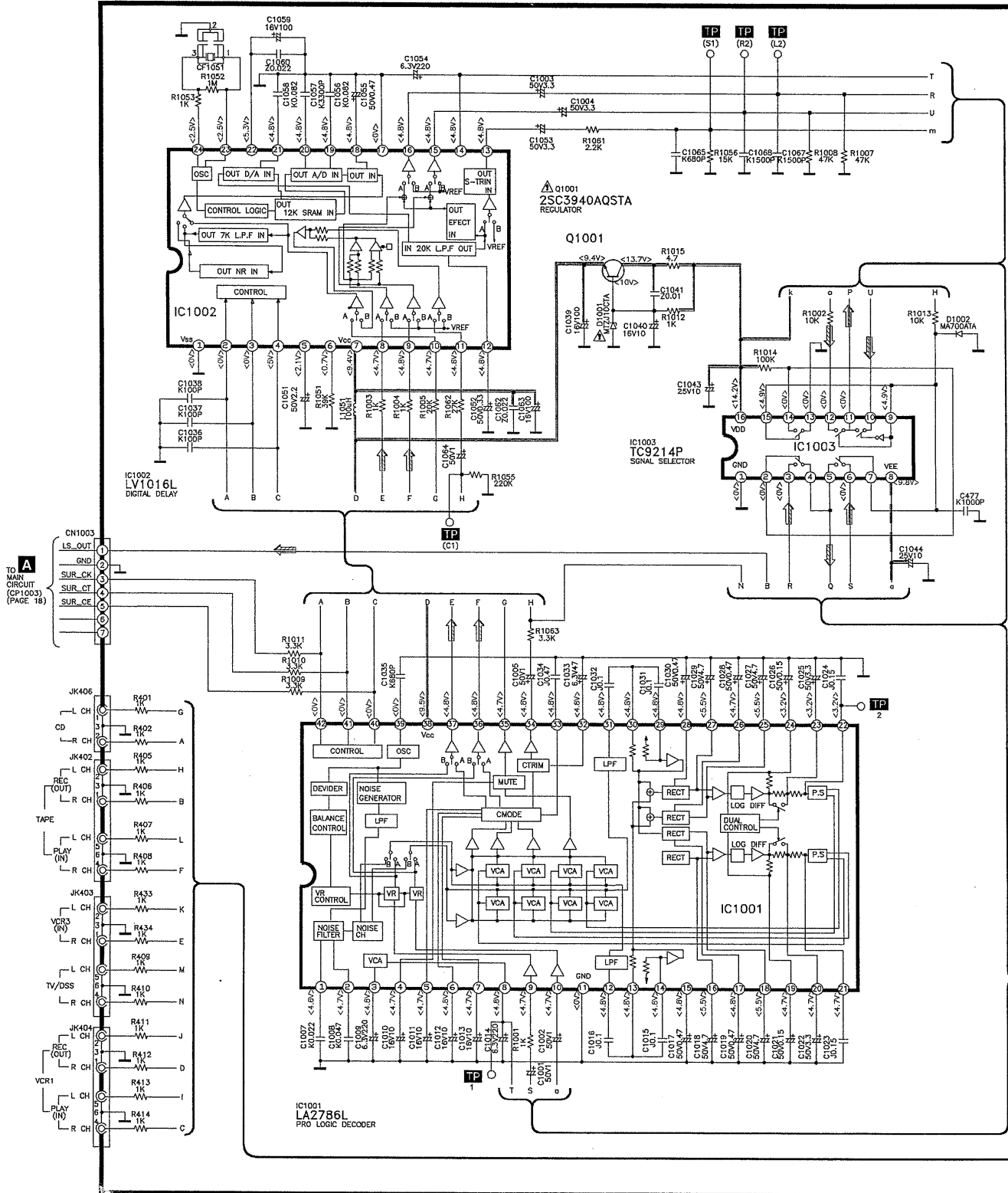

— : +B Line ⇨ : Main Signal Line
 - - - : -B Line ⊞ : Rec Signal Line

M VCR2 CIRCUIT
 (P.C.Board on page 37)

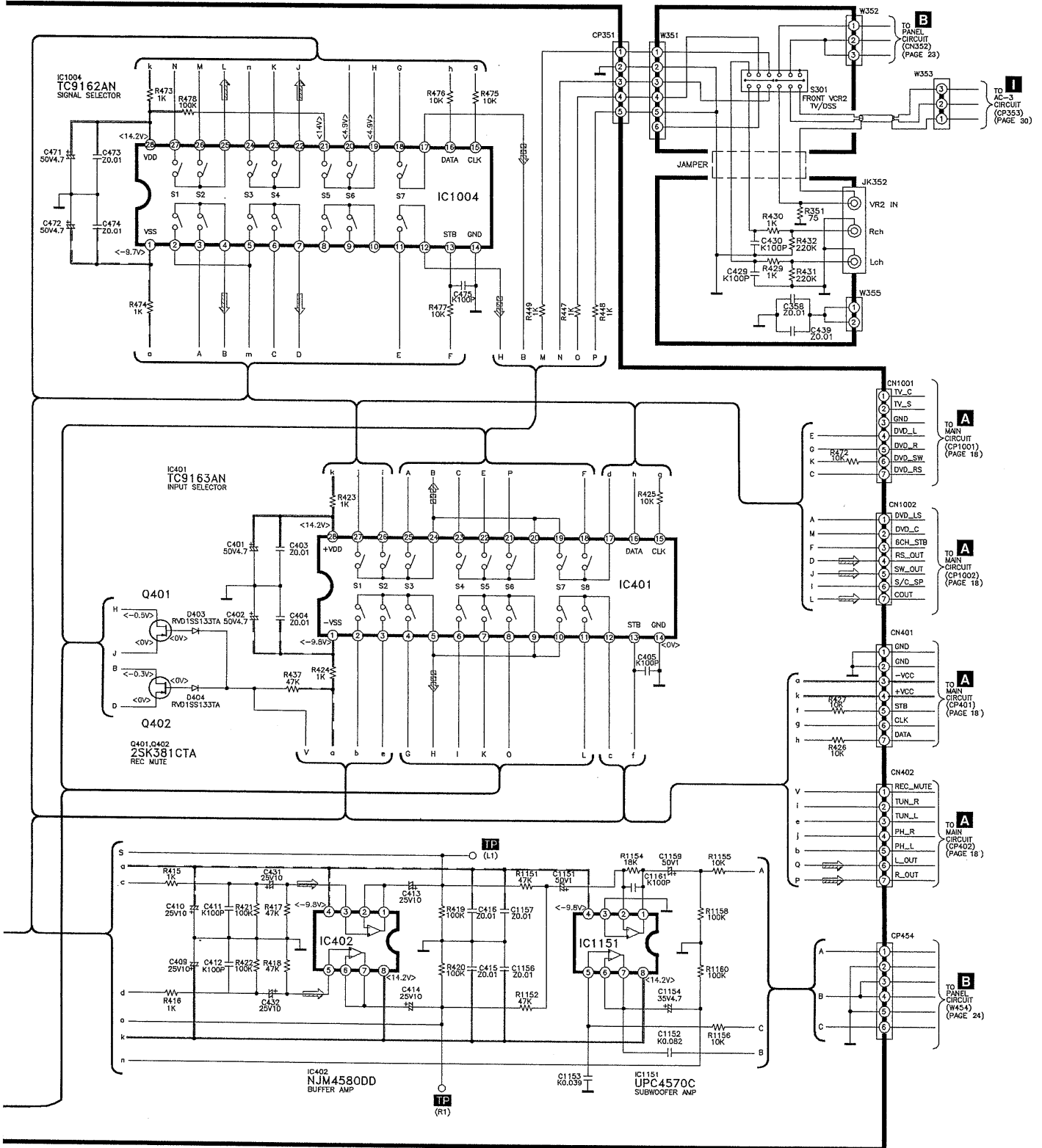

D TUNER PACK CIRCUIT
(P.C.Board on page 40)

— : +B Line **➔** : AM Signal Line **⇨** : FM Signal Line
 - - : -B Line **⬛➔** : AM OSC Signal Line **□⇨** : FM OSC Signal Line

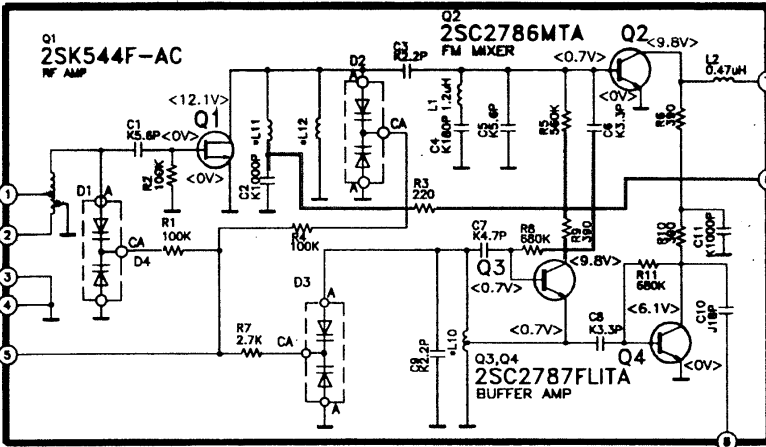

C TUNER CIRCUIT (P.C.Board on page 40)

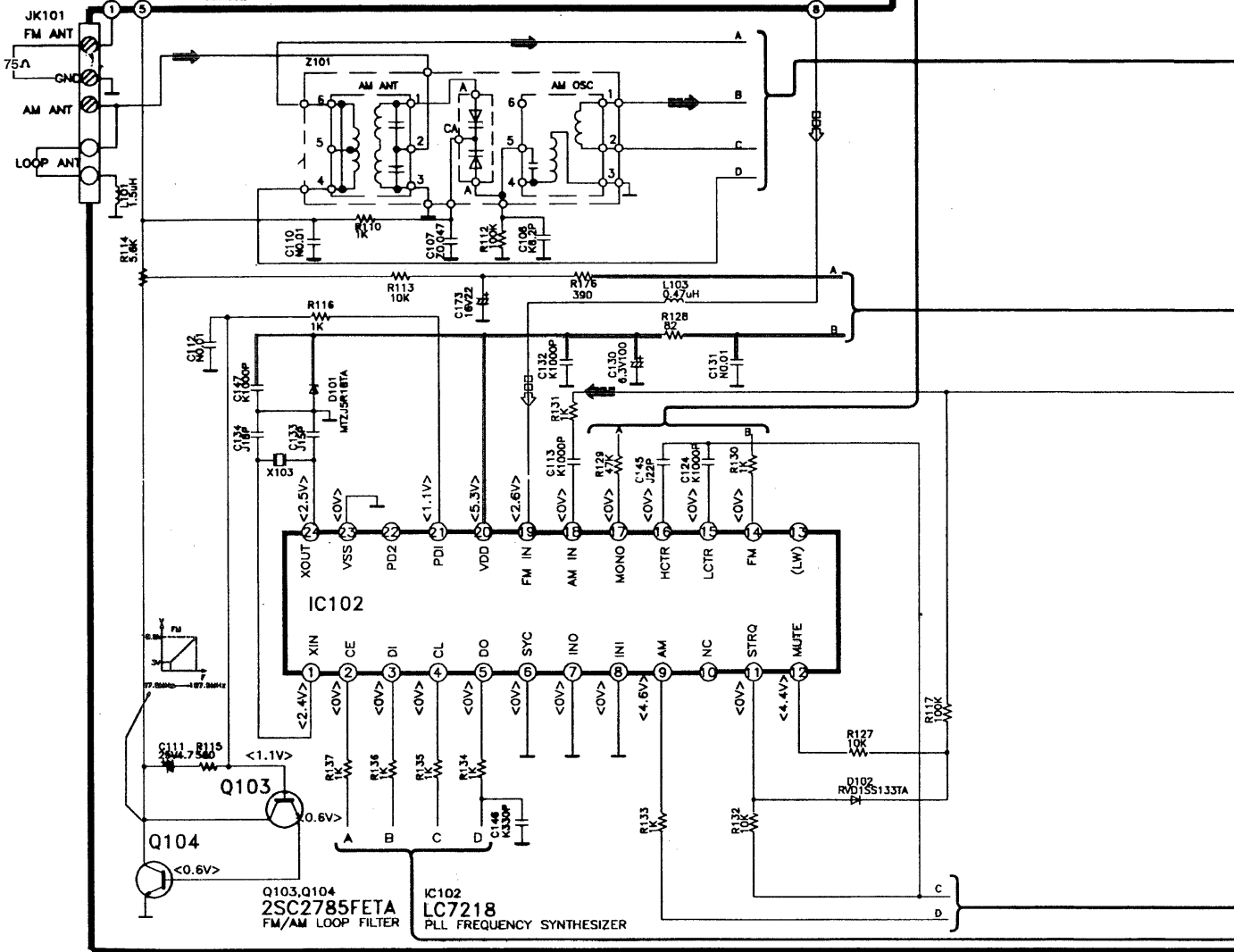

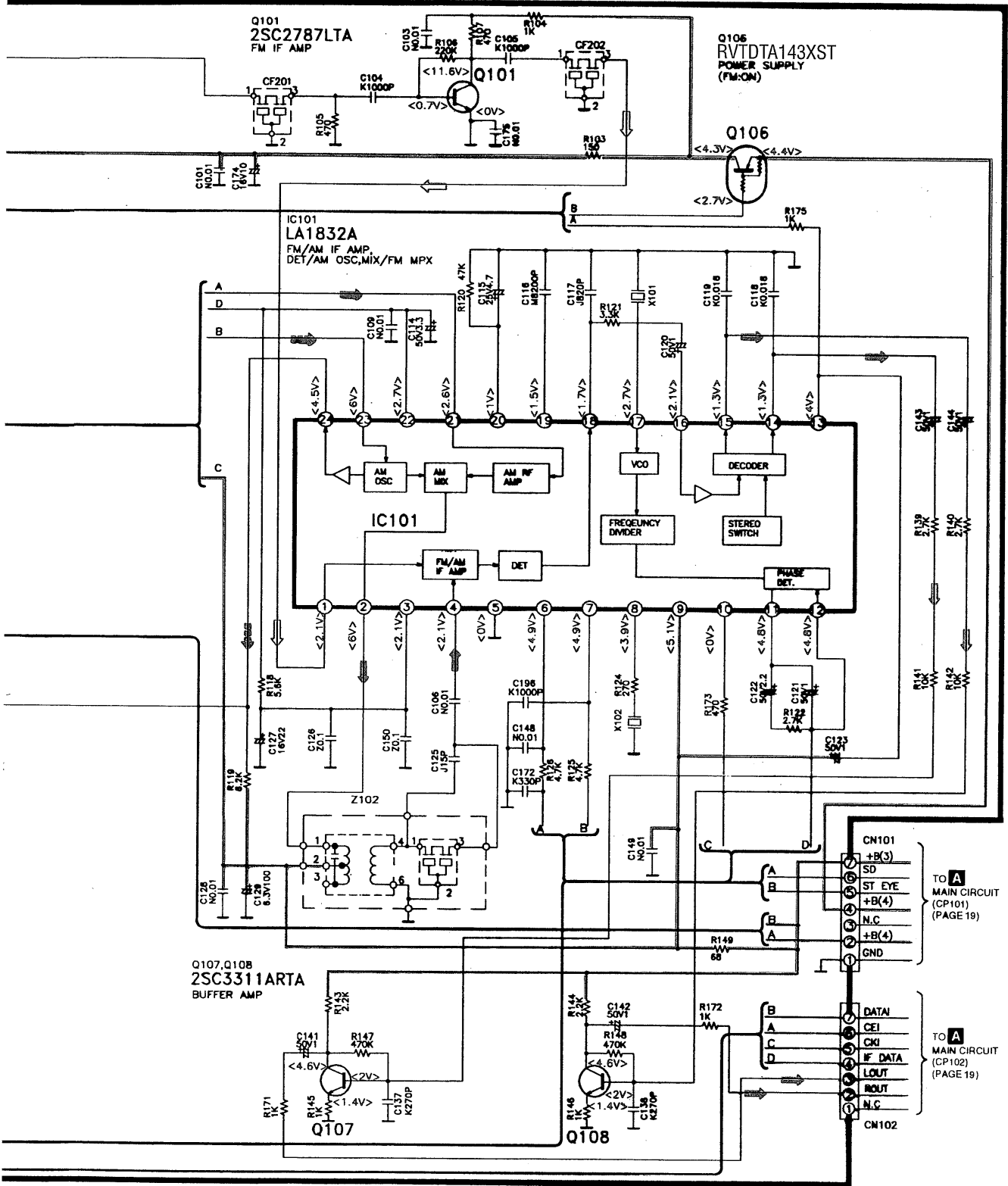
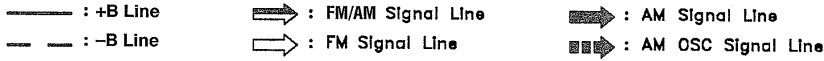

K VOLUME CIRCUIT (P.C.BOARD ON PAGE 35)

— : +B Line - - - : -B Line ⇨ : Main Signal Line

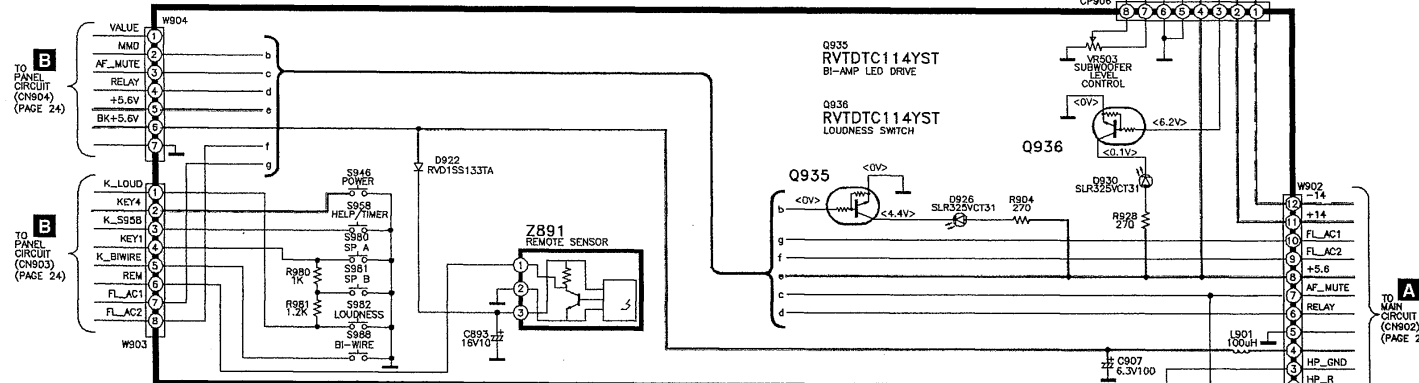
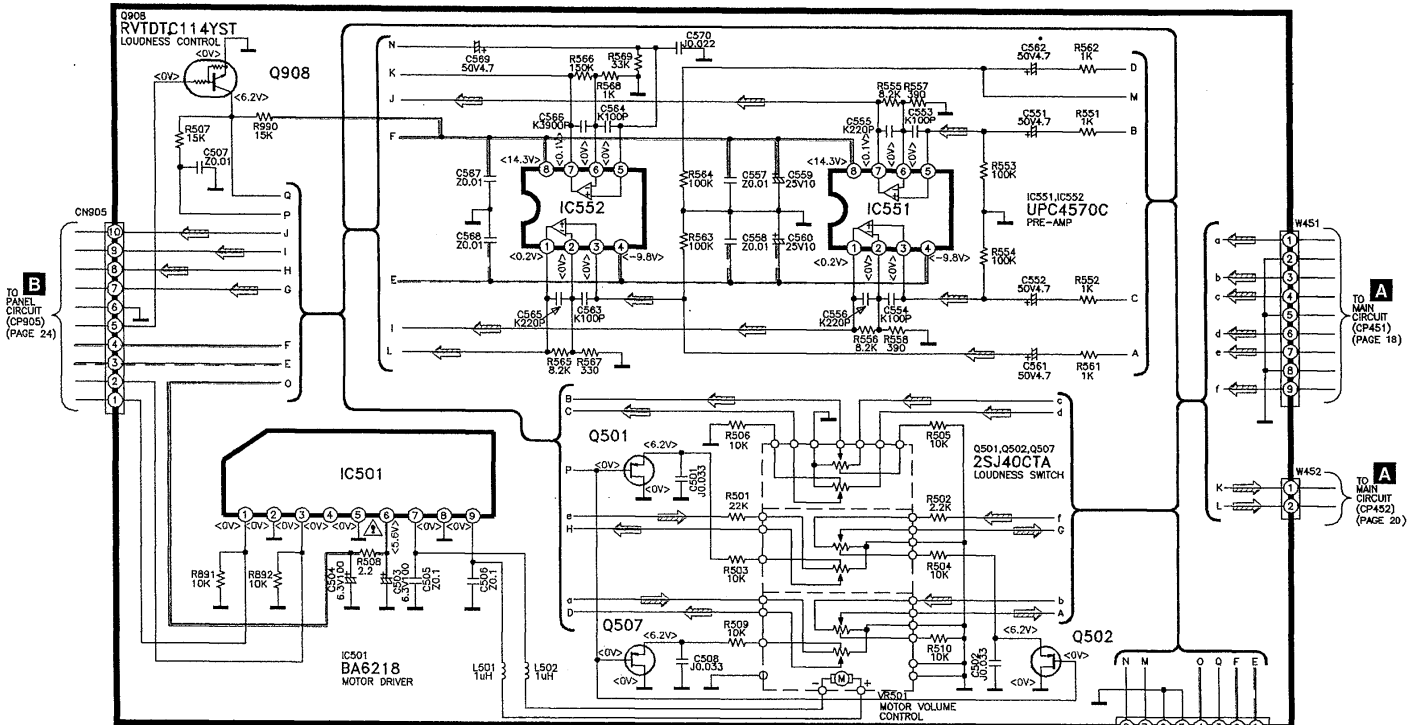

J SUBWOOFER CIRCUIT (P.C.BOARD ON PAGE 34)

Q BLUE LED CIRCUIT (LEFT) (P.C.Board on page 39)

Q BLUE LED CIRCUIT (RIGHT) (P.C.Board on page 39)

P INPUT SELECTOR CIRCUIT (P.C.BOARD ON PAGE 39)

O HEADPHONE JACK CIRCUIT (P.C.Board on page 39)

AC-3 CIRCUIT (P.C.Board on page 38)

— : +B Line - - - : -B Line

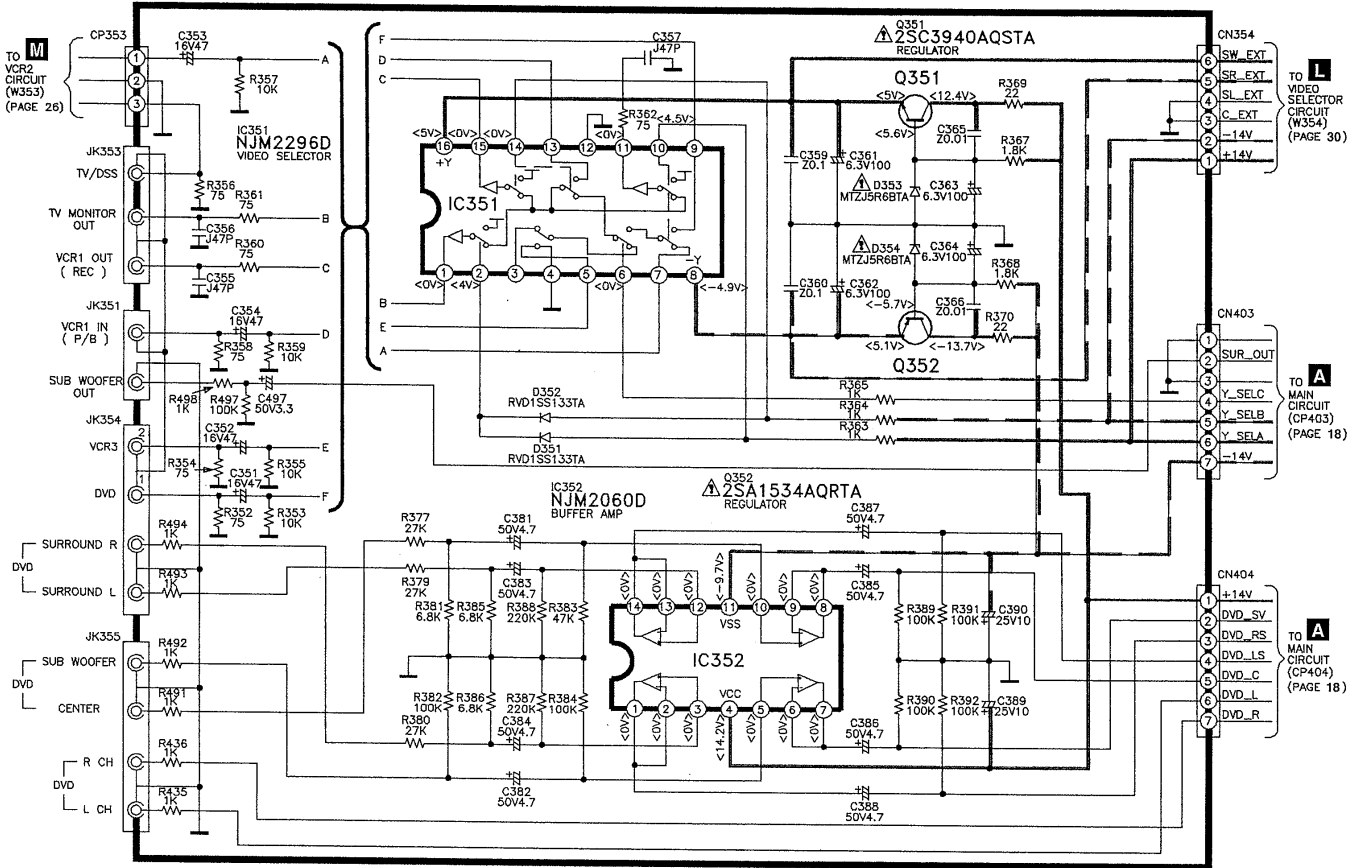

VIDEO SELECTOR CIRCUIT (P.C.Board on page 37)

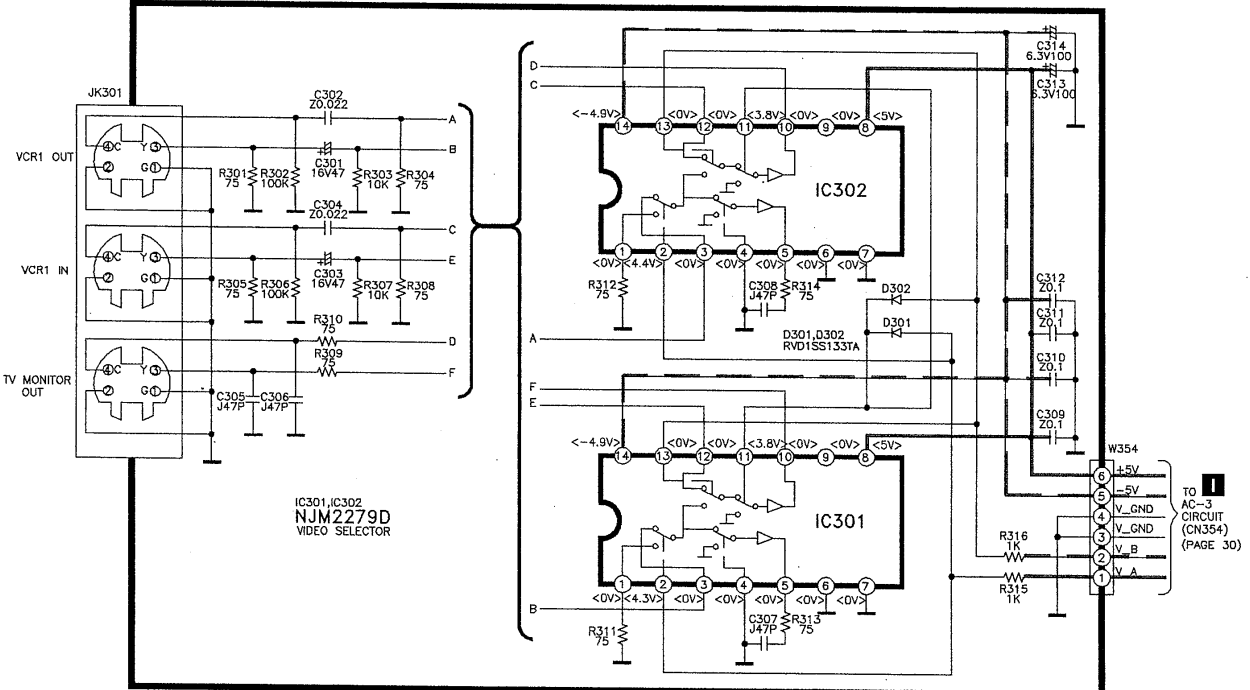

G TRANSFORMER P.C.B. (REP2676A-M)

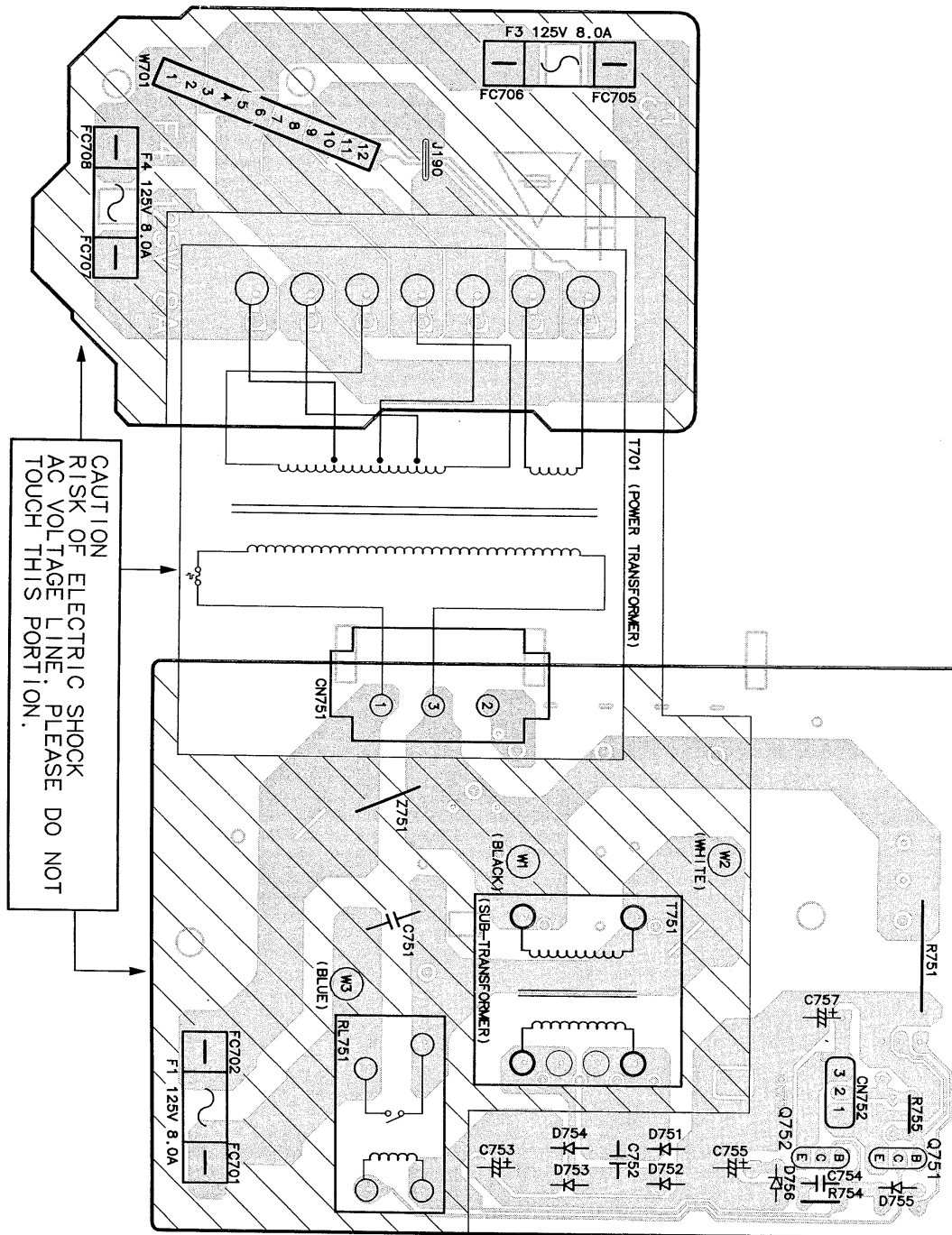

F POWER P.C.B. (REP2678A-P)

Wiring Connection Diagram

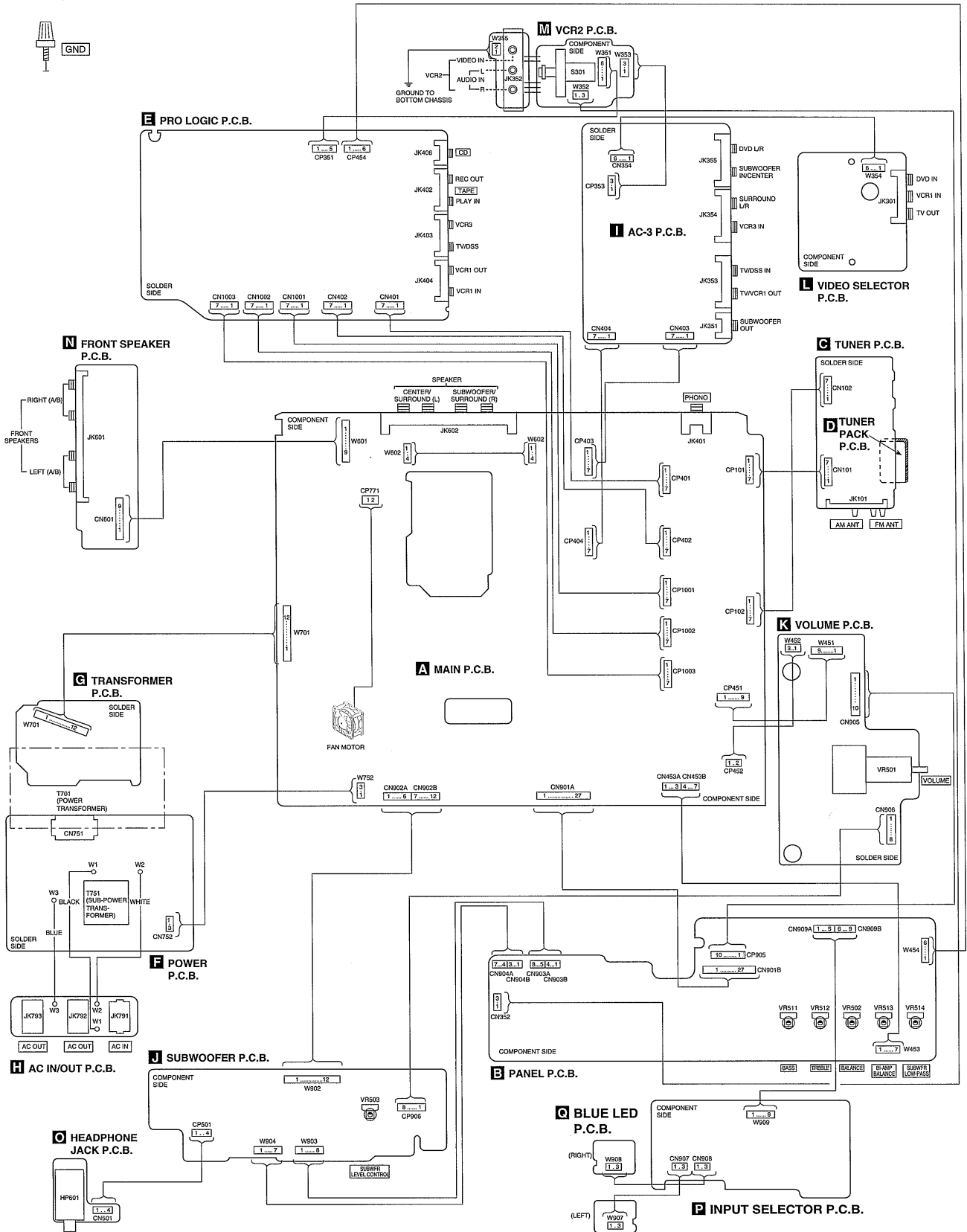

■ Block Diagram

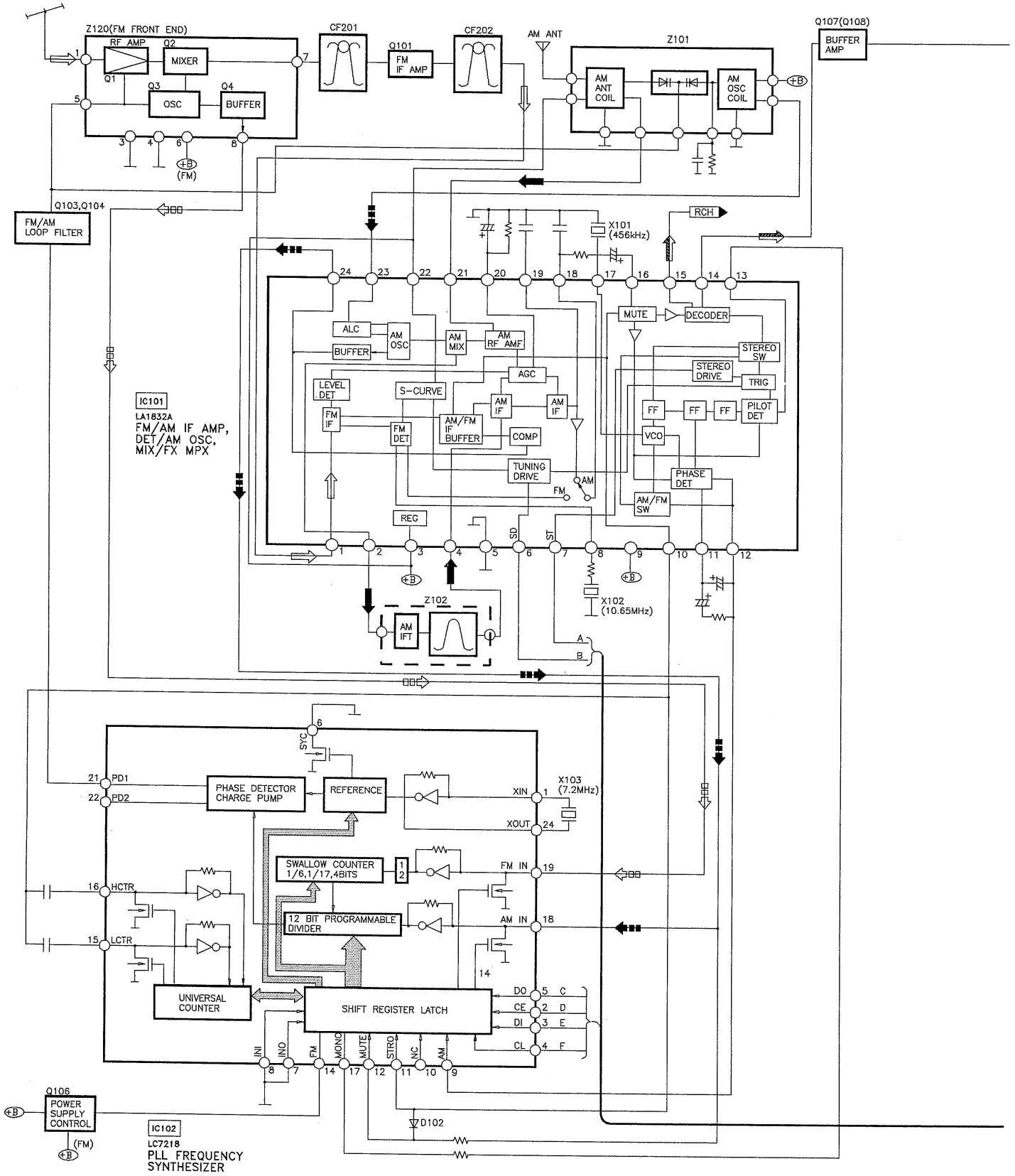

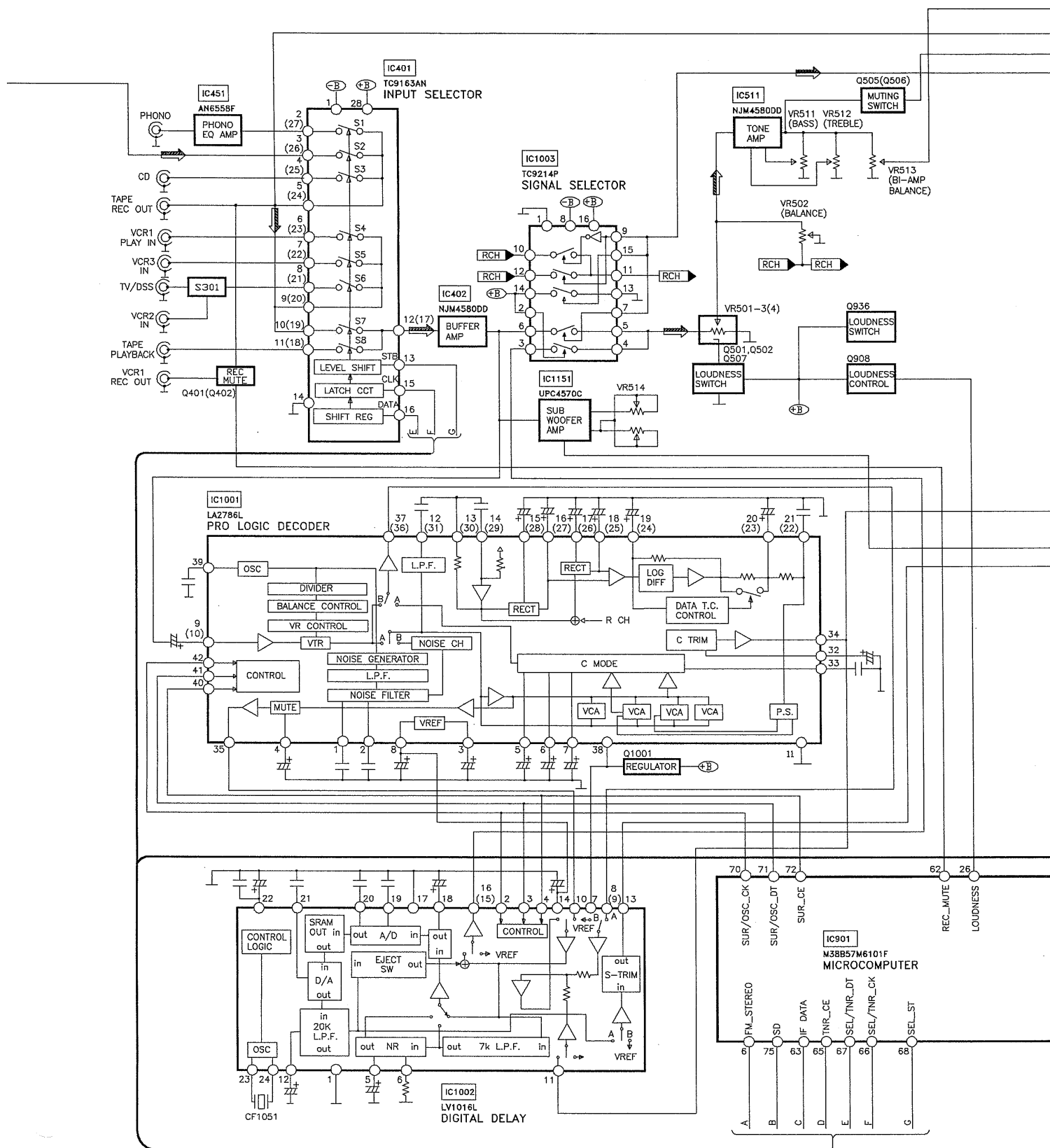

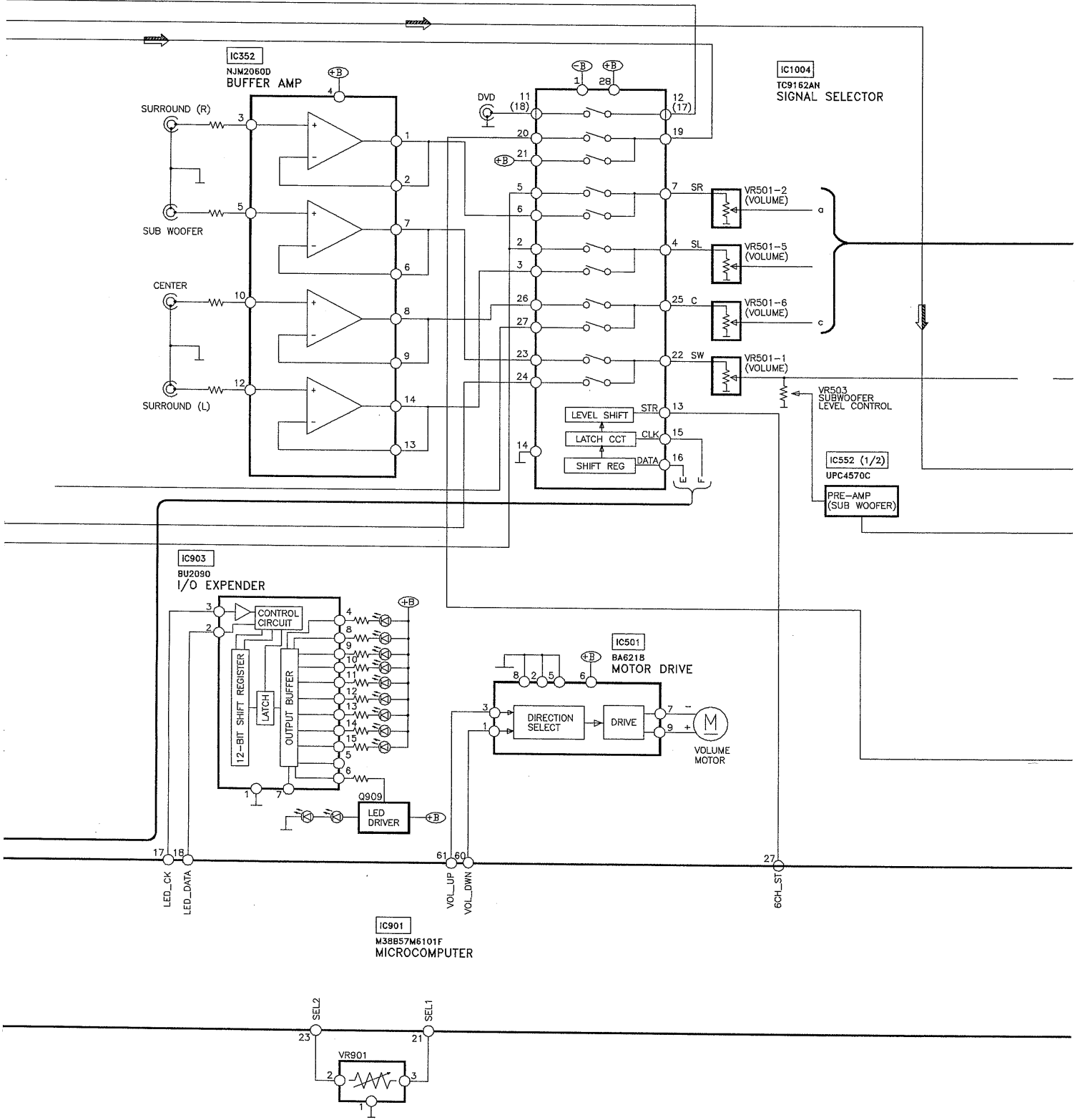

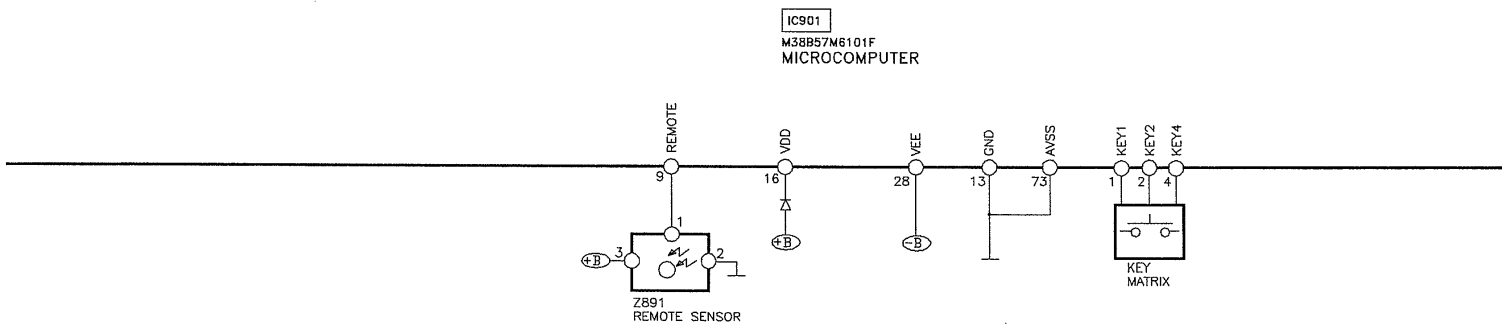
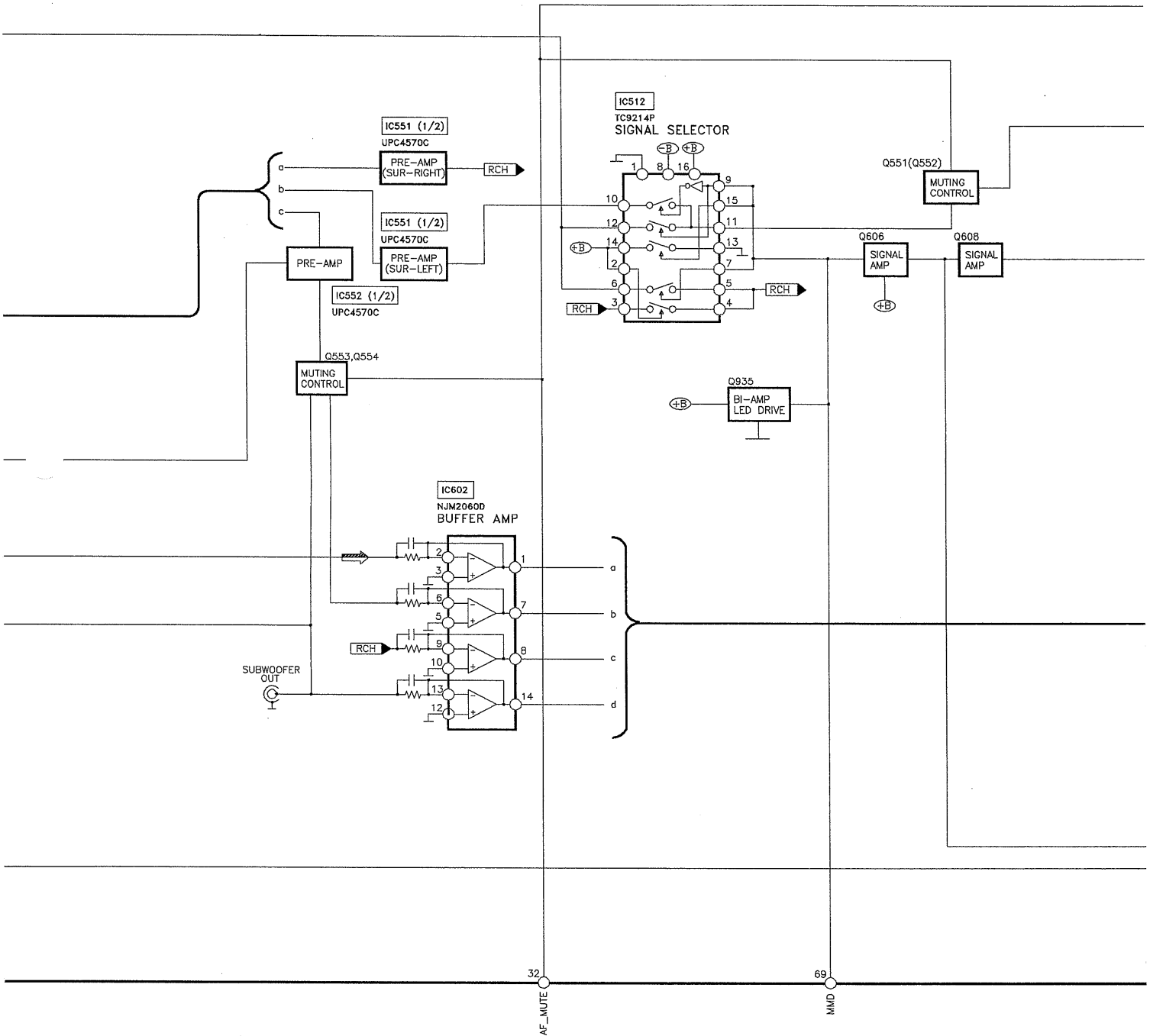

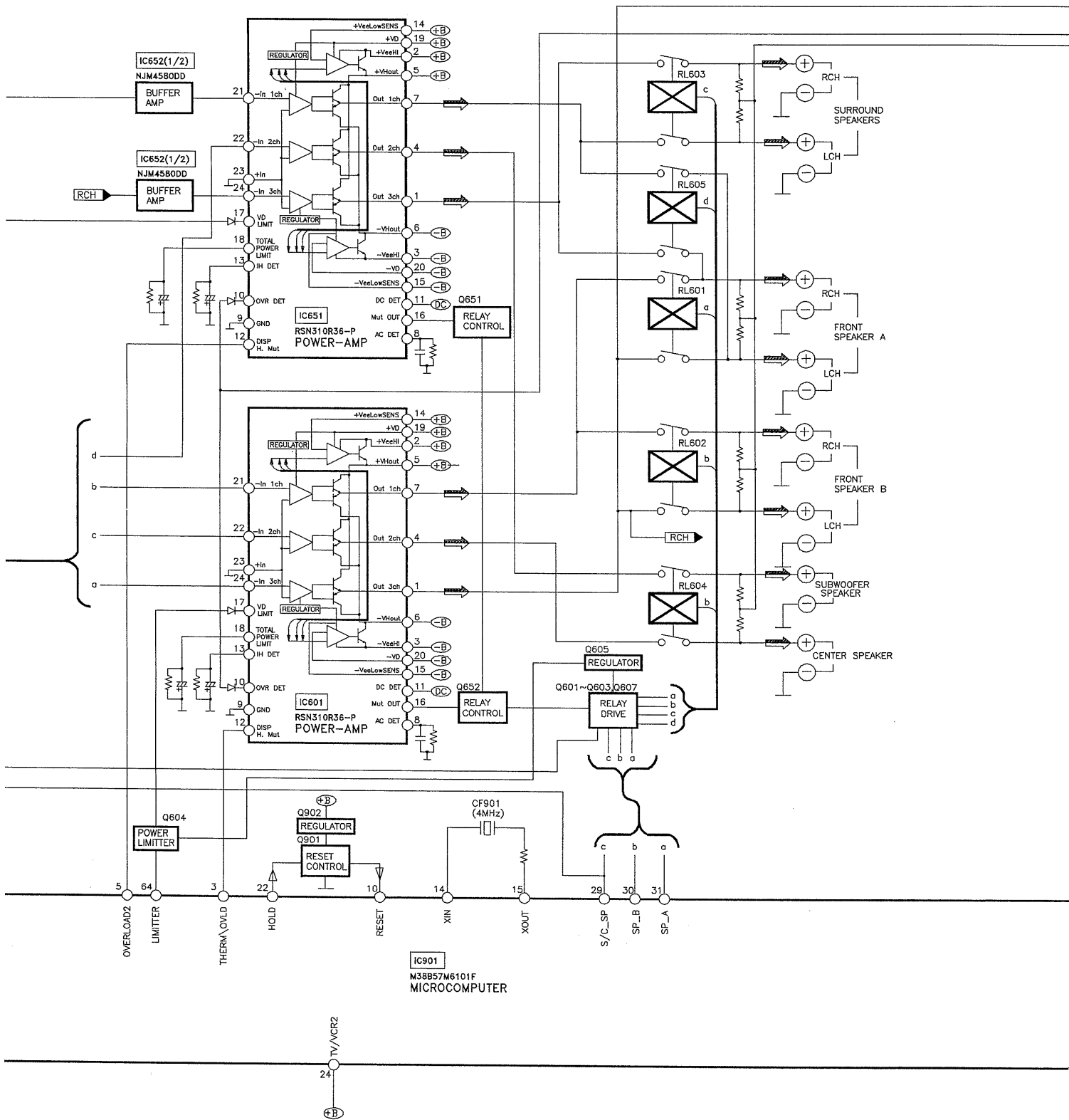

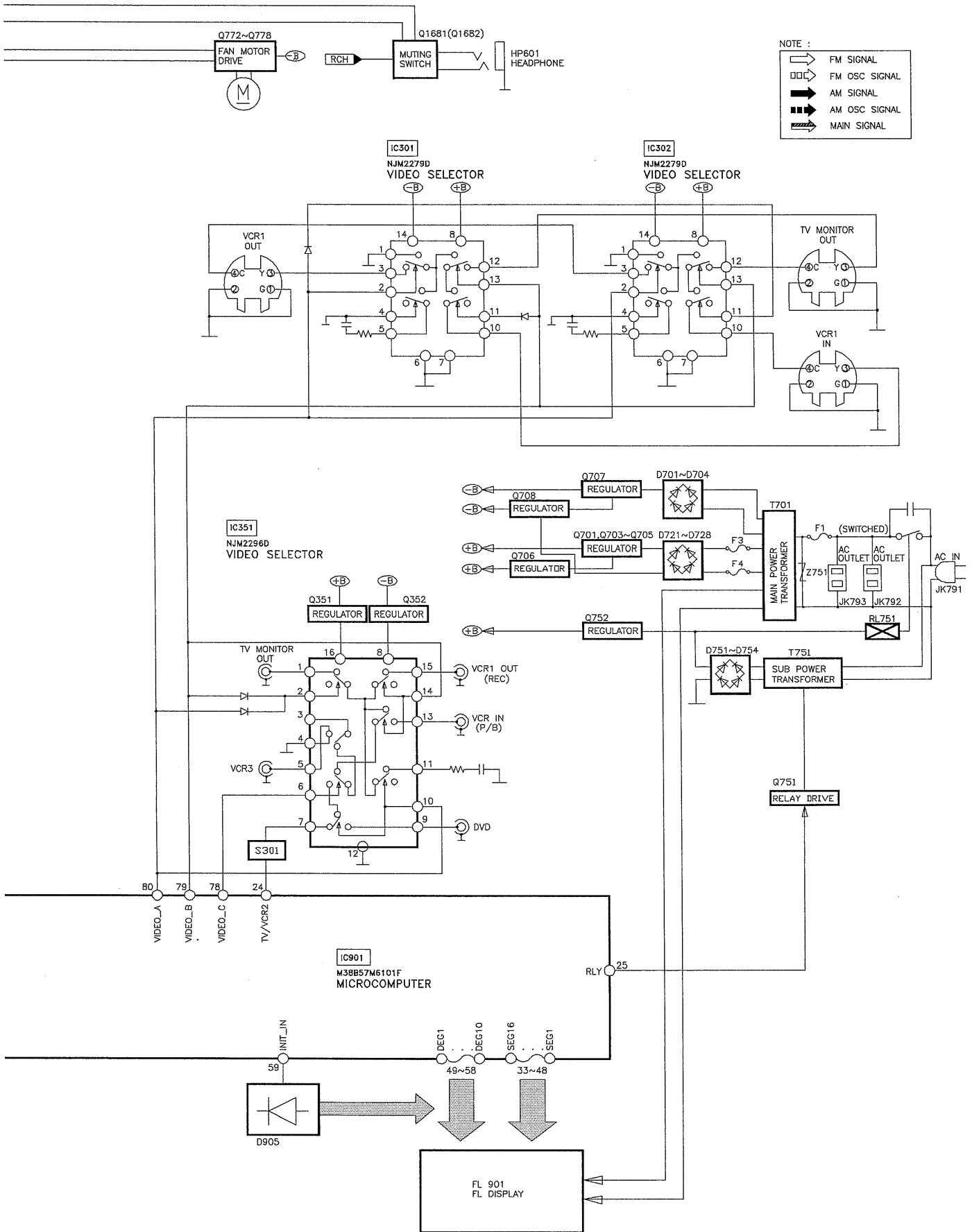

Cabinet Parts Location

