

Service Manual

AV Control Stereo Receiver

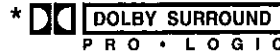

Receiver

SA-AX730

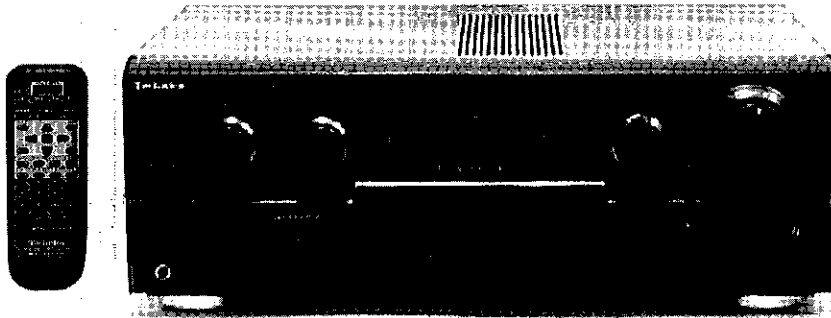

Colour

(K) ... Black Type

Area

Suffix for Model No.	Area	Colour
(E)	Europe	(K)
(EB)	Great Britain	
(EG)	Germany and Italy	

* Manufactured under license from Dolby Laboratories Licensing Corporation. "Dolby", the double-D symbol and "PRO LOGIC" are trade marks of Dolby Laboratories Licensing Corporation.

■ Specifications

■ AMPLIFIER SECTION

Power output		Frequency response	
DIN 1 kHz (T. H. D. 1%)	2 X 100 W (6Ω)	PHONO	RIAA standard curve(30Hz-15kHz) ± 0.8 dB
20 Hz-20 kHz continuous power output		CD, TAPE, DVD, VCR, TV	10 Hz - 40 kHz, ± 3 dB
both channels driven	2 X 80 W (6Ω)	Input sensitivity and impedance	
Total harmonic distortion		PHONO	3 mV / 47 kΩ
rated power at 20 Hz - 20 kHz	0.05% (6Ω)	CD, TAPE, DVD, VCR, TV	200 mV / 22 kΩ
half power at 1 kHz	0.03% (6Ω)	S/N at rated power (6Ω)	
Power output at the Dolby Pro Logic operation		PHONO	70 dB (IHF, A : 80dB)
DIN 1 kHz (T. H. D. 1%)		CD, TAPE, DVD, VCR, TV	75 dB (IHF, A : 85dB)
Front	2 X 100 W (6Ω)	Tone controls	
Center	100 W (6Ω)	BASS	50 Hz, +10 to -10 dB
Surround	2 X 100 W (6Ω)	TREBLE	20 kHz, +10 to -10 dB
Power bandwidth both channels driven,-3dB	10Hz - 40kHz (6Ω)	Output voltage TAPE REC (OUT), VCR OUT	200 mV
Damping factor	30 (6Ω)	Channel balance (250 Hz - 6.3 kHz)	±1 dB
Load impedance		Channel separation	55 dB
Front		Headphones output level and impedance	430 mV / 330Ω
A or B	4-16 Ω	Sub-Woofer frequency response	7 -100 Hz, ±3 dB
A and B	8-16 Ω		
Center	6-16 Ω		
Surround	6-16 Ω		

⚠ WARNING

This service information is designed for experienced repair technicians only and is not designed for use by the general public. It does not contain warnings or cautions to advise non-technical individuals of potential dangers in attempting to service a product. Products powered by electricity should be serviced or repaired only by experienced professional technicians. Any attempt to service or repair the product or products dealt with in this service information by anyone else could result in serious injury or death.

Technics®

© 1999 Matsushita Electronics (S) Pte. Ltd.
All rights reserved. Unauthorized copying
and distribution is a violation of law.

FM TUNER SECTION

Frequency range	87.5 — 108.0 MHz
Sensitivity	
S/N 30 dB	1.5 μ V / 75 Ω
S/N 26 dB	1.3 μ V / 75 Ω
S/N 20 dB	1.2 μ V / 75 Ω
IHF usable sensitivity (IHF' 58)	1.5 μ V / 75 Ω
IHF 46 dB stereo quieting sensitivity	22 μ V / 75 Ω
Total harmonic distortion	
MONO	0.2%
STEREO	0.3%
S/N	
MONO	60 dB (73 dB, IHF)
STEREO	58 dB (67 dB, IHF)
Frequency response 20Hz - 15 kHz	+1 dB, -2 dB
Alternate channel selectivity \pm 400 kHz	65 dB
Capture ratio	1.5 dB
Image rejection at 98MHz	40 dB
IF rejection at 98 MHz	70 dB
Spurious response rejection at 98MHz	70 dB
AM suppression	50 dB
Stereo separation	
1 kHz	40 dB
Carrier leak	
19 kHz	-30 dB (-35 dB, IHF)
38 kHz	-50 dB (-55 dB, IHF)
Channel balance (250 Hz - 6.3 kHz)	\pm 1.5 dB
Limiting point	1.2 μ V

Bandwidth	
IF amplifier	180 kHz
FM demodulator	1000 kHz
Antenna terminal(s)	75 Ω (unbalanced)

AM TUNER SECTION

Frequency range	522 - 1611 kHz (9 kHz steps) 530 - 1620 kHz (10 kHz steps)
Sensitivity	20 μ V, 330 μ V/m
Selectivity (at 999 kHz)	55 dB
IF rejection (at 999 kHz)	50 dB

VIDEO SECTION

Output voltage at 1V Input (unbalanced)	1 \pm 0.1 Vp-p
Maximum input voltage	1.5 Vp-p
Input/output Impedance	75 Ω

GENERAL

Power consumption	240 W (In standby mode : 3 W)
Power supply	AC 230 - 240V, 50 Hz
Dimensions (W x H x D)	430 x 158 x 324.5 mm
Weight	9.7 kg

Notes :

- Specifications are subject to change without notice. Weight and dimensions are approximate.
- Total harmonic distortion is measured by the digital spectrum analyzer.

Contents

	PAGE	PAGE
• Accessories	2	
• Before Repair & Adjustment / Protection Circuitry	2	
• Caution for AC Mains Lead	3	
• Front Panel Controls	4	
• Basic Operations	5	
• Dolby Pro Logic	6 ~ 9	
• Making A Recording	10	
• Using the Remote Control	11	
• Operations Checks	12 ~ 15	
• Terminal Functions of IC's	16	
• Type Illustration of IC's Transistors and Diodes		17
• Wiring Connection Diagram		18
• Block Diagram		19 ~23
• Schematic Diagram		24 ~ 40
• Printed Circuit Board		41 ~ 48
• Cabinet Parts Locations		49
• Replacement Parts List		50 ~ 52
• Resistors & Capacitors		53 ~ 57
• Packing Materials & Accessories		58
• Packaging		58

Accessories

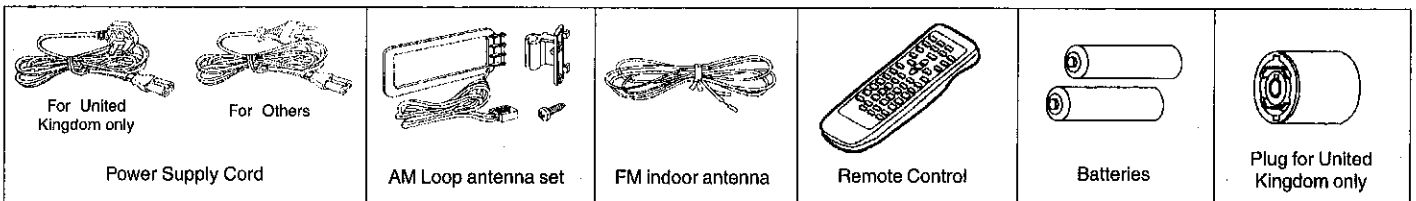

Before Repair and Adjustment

Disconnect AC power, discharge Power Supply Capacitors C703, C704, C705 and C706 through a 10 Ω , 5W resistor to ground. DO NOT SHORT-CIRCUIT DIRECTLY (with a screwdriver blade, for instance), as this may destroy solid state devices. After repairs are completed, restore power gradually using a variac, to avoid overcurrent. Current consumption at AC 230~240 V, 50Hz in NO SIGNAL mode should be 240 ~ 330 mA.

Protection Circuitry

The protection circuitry may have operated if either of the following conditions are noticed :

- No sound is heard when the power is turned on.
- Sound stops during a performance.

The function of this circuitry is to prevent circuitry damage if, for example, the positive and negative speaker connection wires are "shorted", or if speaker systems with an impedance less than the indicated rated impedance of the amplifier are used.

If this occurs, follow the procedure outlines below:

1. Turn off the power.
2. Determine the cause of the problem and correct it.
3. Turn on the power once again after one minute.

Note:

When the protection circuitry functions, the unit will not operate unless the power is first turned off and then on again.

■ Caution for AC Mains Lead



(For "EB" area code model only.)

For your safety, please read the following text carefully.

This appliance is supplied with a moulded three pin mains plug for your safety and convenience.

A 5-ampere fuse is fitted in this plug.

Should the fuse need to be replaced please ensure that the replacement fuse has a rating of 5-ampere and that it is approved by ASTA or BSI to BS1362.

Check for the ASTA mark  or the BSI mark  on the body of the fuse.

If the plug contains a removable fuse cover you must ensure that it is refitted when the fuse is replaced.

If you lose the fuse cover, the plug must not be used until a replacement cover is obtained.

A replacement fuse cover can be purchased from your local dealer.

CAUTION !

IF THE FITTED MOULDED PLUG IS UNSUITABLE FOR THE SOCKET OUTLET IN YOUR HOME THEN THE FUSE SHOULD BE REMOVED AND THE PLUG CUT OFF AND DISPOSED OFF SAFELY.

THERE IS A DANGER OF SEVERE ELECTRICAL SHOCK IF THE CUT OFF PLUG IS INSERTED INTO ANY 13-AMPERE SOCKET.

If a new plug is to be fitted, please observe the wiring code as shown below.

If in any doubt please consult a qualified electrician.

IMPORTANT

The wires in this mains lead are coloured in accordance with the following code:

Blue: Neutral
Brown: Live

As these colours may not correspond with the coloured markings identifying the terminals in your plug, proceed as follows:

The wire which is coloured Blue must be connected to the terminal which is marked with the letter N or coloured Black or Blue.

The wire which is coloured Brown must be connected to the terminal which is marked with the letter L or coloured Brown or Red.

WARNING: DO NOT CONNECT EITHER WIRE TO THE EARTH TERMINAL WHICH IS MARKED WITH THE LETTER E, BY THE EARTH SYMBOL \perp OR COLOURED GREEN OR GREEN/YELLOW.

THIS PLUG IS NOT WATERPROOF—KEEP DRY.

Before use

Remove the connector cover.

How to replace the fuse

The location of the fuse differ according to the type of AC mains plug (figures A and B). Confirm the AC mains plug fitted and follow the instructions below.

Illustrations may differ from actual AC mains plug.

1. Open the fuse cover with a screwdriver.

Figure A

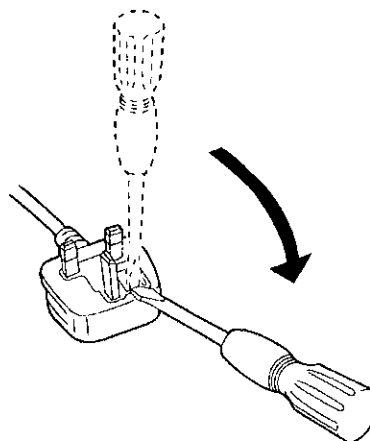
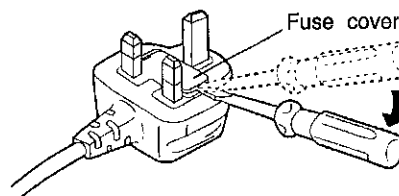

Figure B



2. Replace the fuse and close or attach the fuse cover.

Figure A

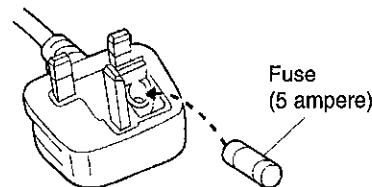
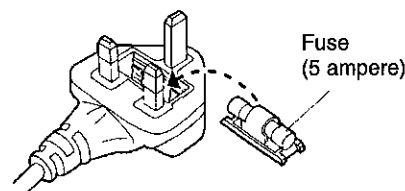
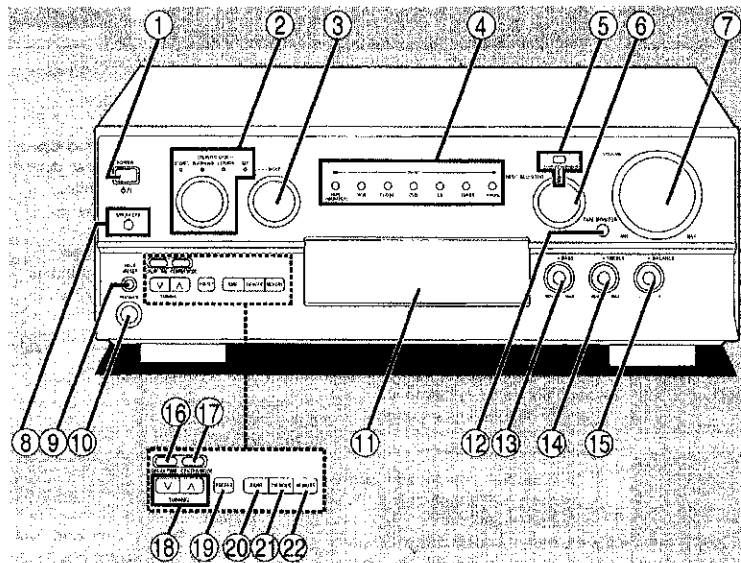

Figure B



Front Panel Controls



No.	Name
-----	------

- ① Power "⏻/⏻" switch (POWER, ⏻/⏻)
Press to switch the unit from on to standby mode or vice versa. In standby mode, the unit is still consuming a small amount of power.
- ② Sound mode selector/indicators
- ③ SFC mode selector (MODE)
- ④ Input indicators
- ⑤ DVD 6ch input select button/indicator (DVD 6CH INPUT)
- ⑥ Input selector (INPUT SELECTOR)
- ⑦ Volume control (VOLUME)
- ⑧ Speaker button (SPEAKERS A, B)
- ⑨ Help/reset button (-HELP -RESET)
- ⑩ Headphones jack (PHONES)
- ⑪ Display
- ⑫ Tape monitor button (TAPE MONITOR)
- ⑬ Bass control (BASS)
- ⑭ Treble control (TREBLE)
- ⑮ Balance control (BALANCE)
- ⑯ Delay time adjust button (DELAY TIME)
- ⑰ Center mode select button (CENTER MODE)
- ⑱ Tuning buttons (TUNING ∇, ∆)
- ⑲ Radio station presetting button (PRESET)
- ⑳ Band select button (BAND)
- ㉑ FM mode select button (FM MODE)
- ㉒ Memory button (MEMORY)

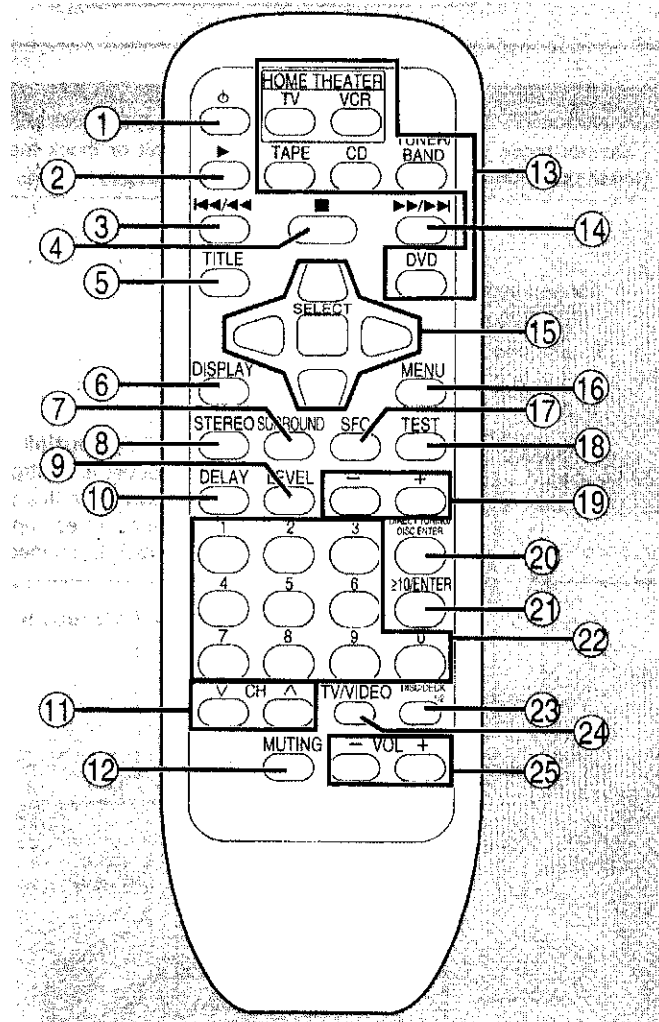

Remote control

- ① Power button (⏻)
- ② ▶ button (▶)
- ③ ◀◀/▶▶ button (◀◀/▶▶)
- ④ ■ button (■)
- ⑤ Title button (TITLE)
- ⑥ Display button (DISPLAY)
- ⑦ Dolby Pro Logic surround select button (SURROUND)
- ⑧ Dolby Pro Logic/SFC off button (STEREO)
- ⑨ Speaker channel select button (LEVEL)
- ⑩ Delay time button (DELAY)
- ⑪ Channel up/down buttons (∇CH∆)
- ⑫ Muting button (MUTING)
- ⑬ Input select buttons (TV, VCR, TAPE, CD, TUNER/BAND, DVD)
- ⑭ ▶▶/▶▶▶▶ button (▶▶/▶▶▶▶)
- ⑮ Cursor/select buttons
- ⑯ Menu button (MENU)
- ⑰ SFC mode select button (SFC)
- ⑱ Test button (TEST)
- ⑲ Delay time/level adjust buttons (-, +)
- ⑳ Direct tuning/disc enter button (DIRECT TUNING/DISC ENTER)
- ㉑ ≥10/enter button (≥10/ENTER)
- ㉒ Numeric buttons
- ㉓ Disc/deck 1/2 select button (DISC/DECK 1/2)
- ㉔ TV/video select button (TV/VIDEO)
- ㉕ Volume buttons (-VOL+)

Basic Operations

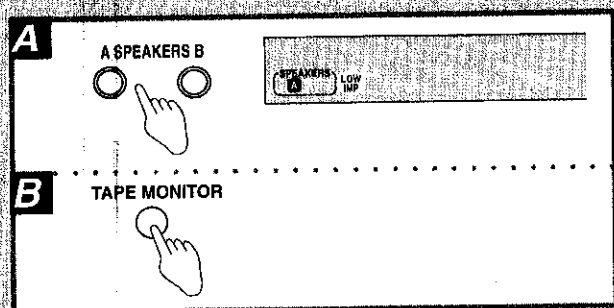
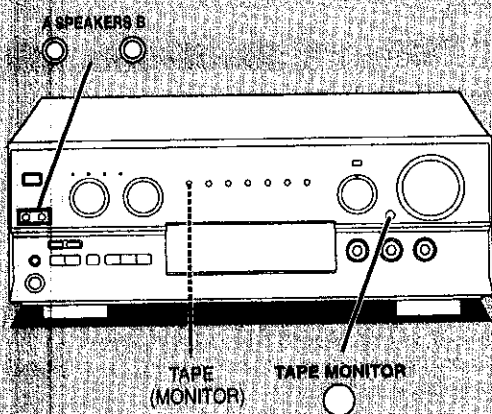
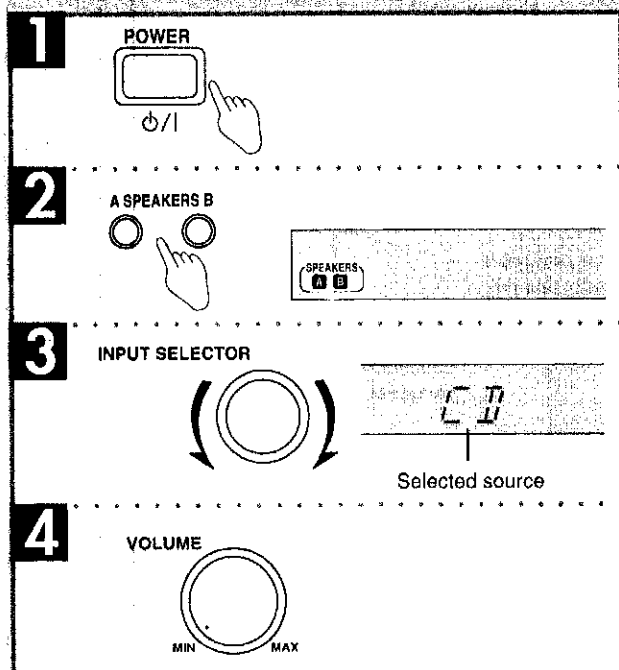
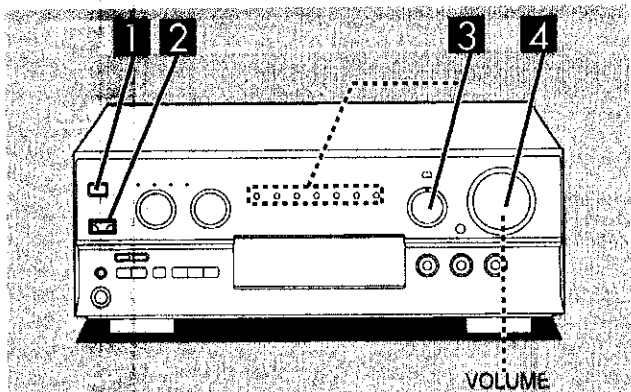

Before operation, set VOLUME to the "MIN" position.

- 1** Press [POWER].
- 2** Press [A] and/or [B] to select the speaker system(s) to be used.
A and B refer to the speaker terminals at the rear of the unit.
- 3** Turn [INPUT SELECTOR] to select and start the desired source.
(Refer to the appropriate operating instructions for details.)

The indicator which corresponds to the selected input source will illuminate.

The selected source will be shown on the display.

TAPE (MONITOR): To listen to cassette tapes

VCR: To watch video tapes

TV/DSS: To watch TV or DSS

DVD: To watch DVD

CD: To listen to compact discs

TUNER: To listen to radio broadcasts

PHONO: To listen to phono discs

If a Dolby Pro Logic or SFC mode has been selected

After displaying the selected source, the display will then change to show the Dolby Pro Logic or SFC mode.

If the source chosen was TUNER then the display will change again to show the frequency.

Note

To watch a video (or DVD) or the TV, set the TV to either the TV mode or VIDEO mode.

For your reference

If you are using a VCR and you select TAPE, CD, TUNER, or PHONO, the picture will remain on the screen.

- 4** Adjust the volume.

When you finish listening

Be sure to reduce the volume level, and switch the power to the standby condition by pressing [POWER].

When using speakers under 8 Ω **A**

Press and hold [A] or [B] until "LOW IMP" lights up on the display.

If even one of the speakers being used has an impedance under 8 Ω , press and hold down either button A or button B for 4 seconds or more to set the impedance to LOW.

(Press and hold down once again for 4 seconds or more to turn it off.)

Note that when "LOW IMP" is illuminated, speakers **A** and **B** cannot both be used at the same time.

To change a speaker:

e.g. To use speaker **B**, press [A] (**A** goes out), and then press [B] to activate speaker **B**.

Tape monitor **B**

If [TAPE MONITOR] is pressed while a source other than "TAPE (MONITOR)" is selected, the "TAPE (MONITOR)" indicator lights and the tape monitor comes on.

Sources other than tape can still be selected with [INPUT SELECTOR] while the "TAPE (MONITOR)" indicator is on.

Press [TAPE MONITOR] again to turn the tape monitor off.

(➔ See "Making a recording" for details on how to use the tape monitor during recording.)

Dolby Pro Logic

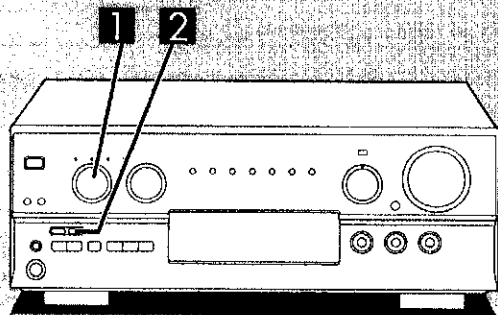

1 Turn the sound mode selector to select "SURROUND".

2 Press [CENTER MODE] to select the correct center mode.

3 Press [TEST] to output a test signal.

4 Press [VOL (-) or (+)] to set the volume level normally used for enjoying the source.

5 Press [LEVEL] to select the center or surround speakers.

6 Press [-] or [+] to adjust the output level.

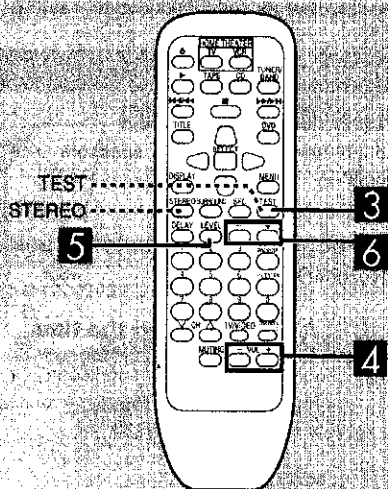

Setting the center mode and adjusting speaker output level

- When ready to adjust speaker output level, situate yourself where you would normally be listening.
- First turn ON the speakers with SPEAKER A on the receiver.
- If front speaker volume is unbalanced, adjust the balance with [BALANCE].

Note

Ensure the front speakers are connected to the A terminals when you use Dolby Pro Logic. The Dolby Pro Logic modes cannot be turned on if "SPEAKERS B" is selected.

The following steps are for setting the output level of the front speakers and the center/surround speakers to the same listening level.

1 Turn the sound mode selector to select "SURROUND".

Note

1. Select "3 STEREO" if surround speakers have not been connected.
2. Remember you cannot adjust the output level of the surround speakers if you selected "3 STEREO" mode.

2 Press [CENTER MODE] to select the correct center mode.

When the button is pressed, the current center mode is displayed. Pressing it again changes the center mode.

NORMAL

When the center speaker is smaller than the front speakers.

WIDEBAND

When the center speaker is the same size as or larger than the front speakers.

PHANTOM SURROUND mode only

When no center speaker is connected.

Note

In the PHANTOM mode, the sound which would have been sent to the center speaker will be divided equally between both the left and right front speakers.

by remote control only

3 Press [TEST] to output a test signal.

The speaker outputting the test signal is displayed while the test is running.

L : Front speaker (Left) R : Front speaker (Right)
C : Center speaker S : Surround speakers

The subwoofer is muted while testing.

In the PHANTOM mode, the center speaker is OFF, so there is no center test signal and "C" is not displayed.

4 Press [VOL (-) or (+)] to set the volume level normally used for enjoying the source.

5 Press [LEVEL] to select the center or surround speakers.

6 Press [-] or [+] to adjust the output level.

Adjust the output level of each speaker from the listening position until they are all identical.

- : Decrease the output level.

+ : Increase the output level.

Output level can be varied within a range of -12 dB to +12 dB with front speaker output level serving as the zero point.

Note

During steps 5 and 6 above the test signal sequence is interrupted and the signal will only come from the selected speaker. The sequence will resume when adjustments are stopped.

To stop the test signal

Press [TEST].

To turn off the Dolby Pro Logic systems

Press [STEREO].

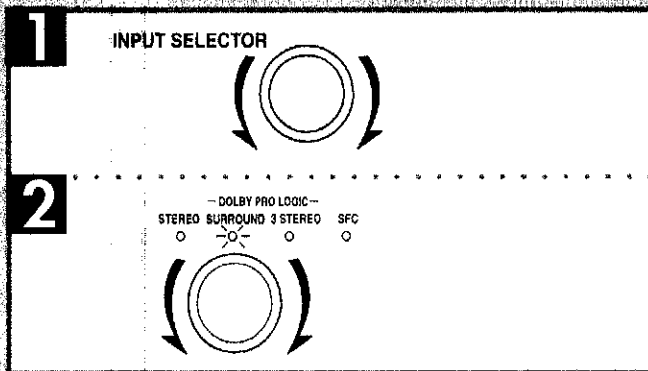
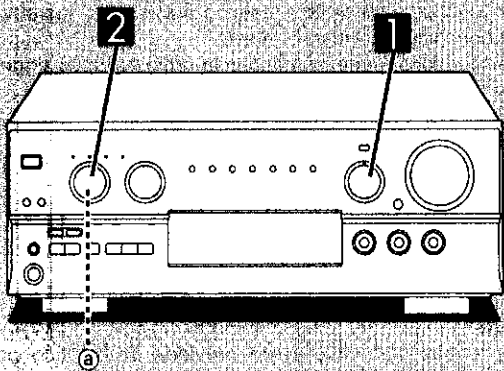
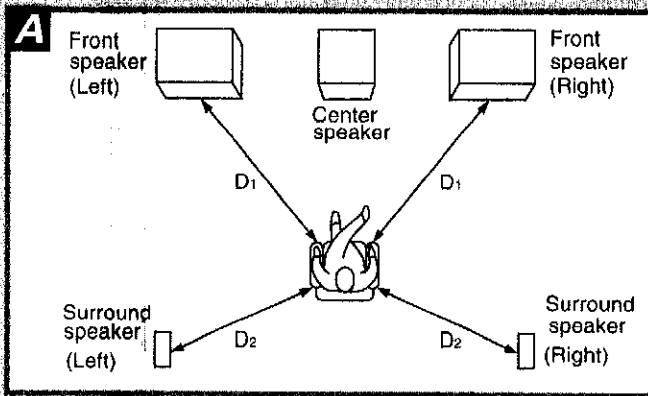
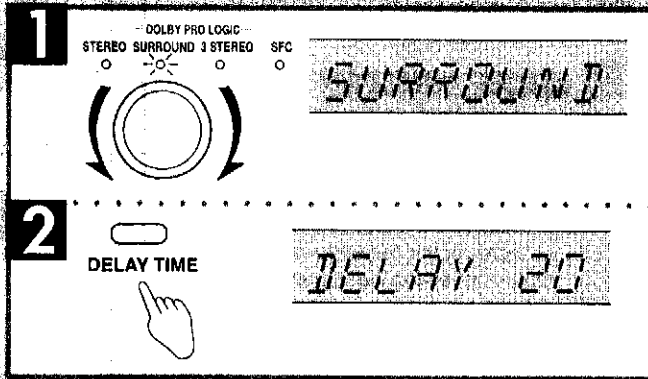
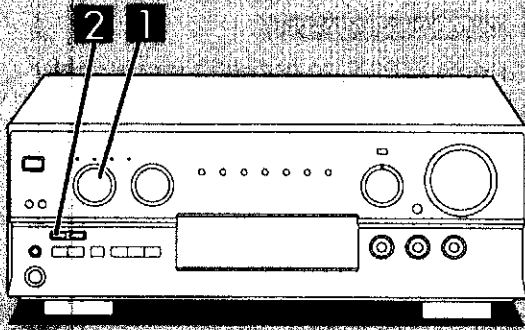

Adjusting the delay time

When enjoying with SURROUND only

Adjust the sound from the surround speakers until the proper effect is produced.

1 Turn the sound mode selector to select "SURROUND".

2 Press [DELAY TIME] to set the time.

When the button is pressed, the current delay time is displayed.

Each time the button is pressed, the delay time will increase by 5 ms within a range of 15 ms to 30 ms.

The standard setting is 20 ms.

To calculate the delay time A

D₁: Distance from front speakers

D₂: Distance from surround speakers

• If D₁ is equal to or less than D₂

Set to 15 ms.

• If D₂ is less than D₁

Start at 15 ms and increase by 5 ms for every 1.5 m of difference between D₁ and D₂.

Enjoying SURROUND or 3 STEREO

1 Turn [INPUT SELECTOR] to select and start the desired source.

2 Turn the sound mode selector to select "SURROUND" or "3 STEREO".

Note

When employing SURROUND, use software recorded in Dolby Surround.

For your reference

You can set the Dolby Pro Logic mode for each source. Each source will retain the selected mode.

To turn off the Dolby Pro Logic systems

Turn the sound mode selector (2) to select "STEREO".

Sound Field control (SFC)

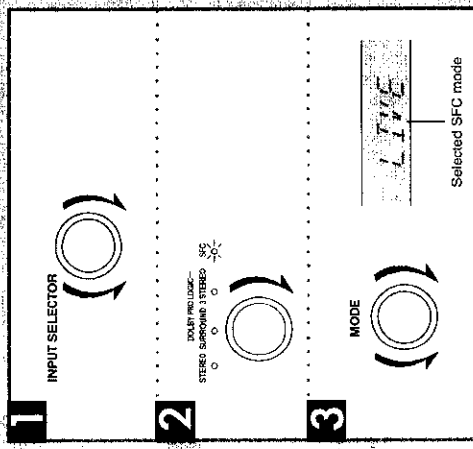
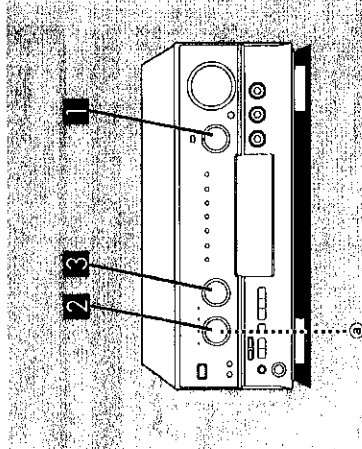

The SFC function gives presence and spread thereby enhancing and enriching the music or movie. Read the following explanations in order to better understand how to make your selection.

Note: The center speaker is not used in the hall, and simulated modes.

HALL
This mode imparts a reflection and spread which will make you feel as if you are in a large concert hall.

CLUB
Like a jazz club, this mode provides an exciting and intimate atmosphere. It simulates the sound field of a relatively small room having a low ceiling and hard reflective surfaces, for a "live" sound with enhanced presence to bring the performers up close.

LIVE
Primarily for vocal pieces, this mode adds gloss to the vocals and you'll feel as though you were hearing a live stage performance.

THEATER
You can clearly perceive the directions and source of the movie. Real ambience of sound can also be recreated naturally using this mode. **THEATER** mode can be used with stereo sources not encoded with Dolby Surround.

Note: When using Dolby Surround encoded materials, select "SURROUND".

SIMULATED (SIM SURR)
Choose this mode if little or no sound will be heard from the surround speakers. You can feel as if you were in a more expanded space adding to the actual sound from the source. This mode also adds effect to monaural sources by outputting sound from surround speakers.

1 Turn [INPUT SELECTOR] to select and start the desired source.

2 Turn the sound mode selector to select "SFC".

3 Turn [MODE] to select the desired SFC mode.

Note: The SFC mode can also be selected by directly turning [MODE] in step 2 instead of selecting "SFC".

For your reference
You can set the SFC mode for each source. Each source will retain the selected mode.

To turn off the SFC function
Turn the sound mode selector (3) to select "STEREO".

Note: Ensure the front speakers are connected to the A terminals when you use SFC. The SFC modes cannot be turned off if "SPEAKERS B" is selected.

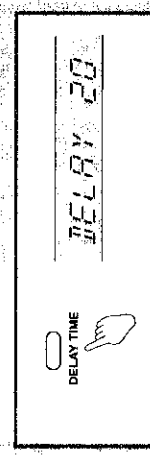
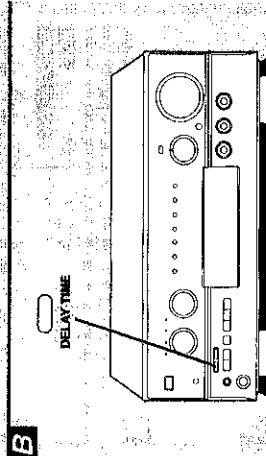
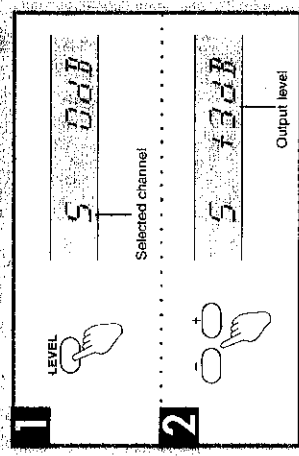
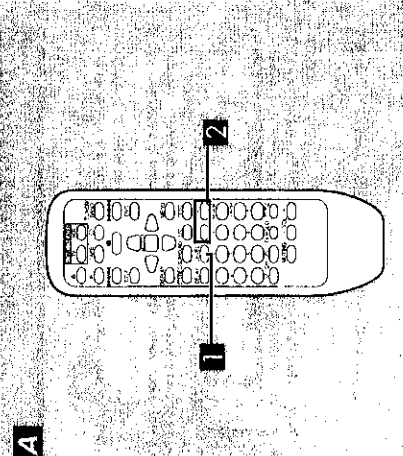

Adjusting field of sound

With this unit, you can adjust speaker volume. Adjust the field of sound while listening to a source.

To adjust the volume of the center and surround speakers A by remote control only

1 Press [LEVEL] to select the center or surround speakers.

Note: You can adjust the center speaker volume only in the theater mode.

2 Press [+] or [-] to adjust the output level.

To adjust the delay time B

Press [DELAY TIME] to set the time.

When the button is pressed, the current delay time is displayed. Each time the button is pressed, the delay time will change.

The delay time increments are different depending on the SFC mode. Select a delay time setting to accommodate to your individual needs.

SFC modes	Available delay time setting (ms)
HALL	20, 25, 30, 40, 50
CLUB	0, 15, 20, 25, 30
LIVE	15, 20, 30, 40, 50
THEATER	15, 20, 25, 30, 40
SIMULATED	75, 20, 25, 30, 40

The figures in bold italics are the factory settings.

DVD 6CH INPUT Mode

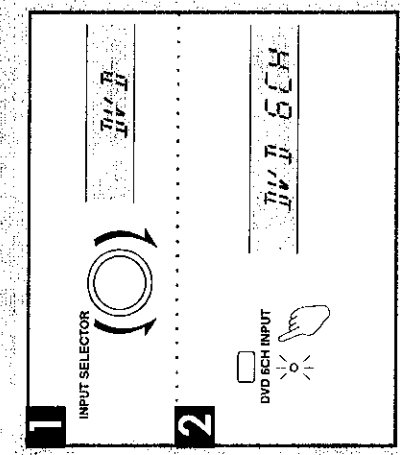
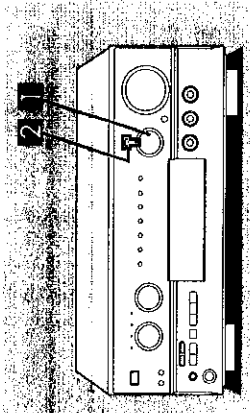

This receiver can playback 6 channel discrete sound. It has terminals for connecting to a component with 6 channel discrete output, such as a DVD player.

6 channel discrete output makes playback sound more real by adding depth, movement, position and other characteristics to the field of sound. It will make you feel as if you were at the movie theater when in your own home.

To enjoy 6 channel discrete output sound
 You have to connect a DVD player, Digital Surround Processor or other component that has 6 channel discrete output capabilities.

- 1 Turn [INPUT SELECTOR] to select "DVD".**
 - 2 Press [DVD 6CH INPUT] to select "DVD 6CH".**
 Changes as follows, each time the button is pressed.
 DVD 6CH ⇌ DVD (2CH)
- The "DVD 6CH INPUT" indicator lights when "DVD 6CH" is selected.
- If you press this button while another source (CD, PHONO, etc.) is selected, the receiver switches the source to DVD and engages the DVD 6CH INPUT mode.
- 3 Start the desired source.**
 Follow your equipment's operating instructions.

NOTE
 You cannot select Dolby Pro Logic or any of the SFC modes while in the DVD 6CH INPUT mode.

NOTE
 Ensure the front speakers are connected to the A terminals when you use DVD 6CH INPUT mode. The DVD 6CH INPUT mode cannot be turned on if "SPEAKERS B" is selected.

About the HELP function

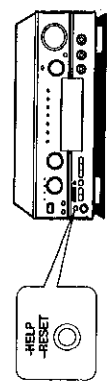

If you make a mistake in operation or if sound output stops due to some operation which was performed, the HELP function displays information which can be useful for indicating the method by which this condition can be remedied.

If "ERROR" or scrolling characters (for instance, "SPEAKER OFF NOW") appear on the display during operation, carry out the following operation.

Press [HELP/-RESET].
 The method for remedying this situation will be displayed.

For your reference
 If the above button is pressed for 2 seconds or more until "RESET" appears on the display, the operation settings for the unit will be initialized to the settings made at the time of shipment. However, any broadcasting stations which have been preset into memory will not be erased at this time.

Other Functions

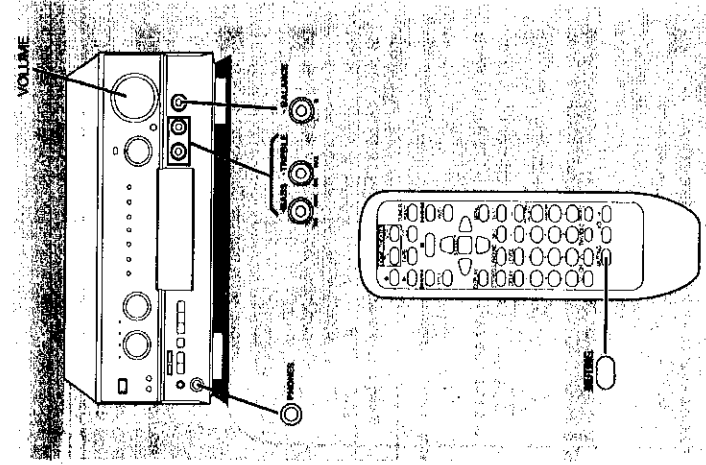

- A To adjust the tone quality**
 Turn [BASS] to adjust the low frequency sound.
 Turn [TREBLE] to adjust the high frequency sound.
- B To adjust the sound balance**
 Turn [BALANCE] to adjust the left/right sound balance.
- C To mute the sound level**
 By remote control only

Press [MUTING]
 The message "MUTING ON NOW" runs repeatedly from right to left across the display as long as the muting function is on.

Press once again to return to the previous volume level.

NOTE
 When the receiver is turned off, the muting operation will be automatically cancelled.

- D To listen through headphones**
 - 1 Reduce the volume level.**
 - 2 Connect the headphones.**
 Plug type: 6.3 mm (1/4 in.) stereo
 - 3 Adjust the volume level.**

If you do not want sound from the speakers, press [SPEAKERS] button(s) and check the speaker indicator(s) goes out.

If a subwoofer is connected to your system, turn off the power to it (or the subwoofer amp you are using) or lower the volume to the minimum level.

NOTE
 Avoid listening for prolonged periods of time to prevent hearing damage.

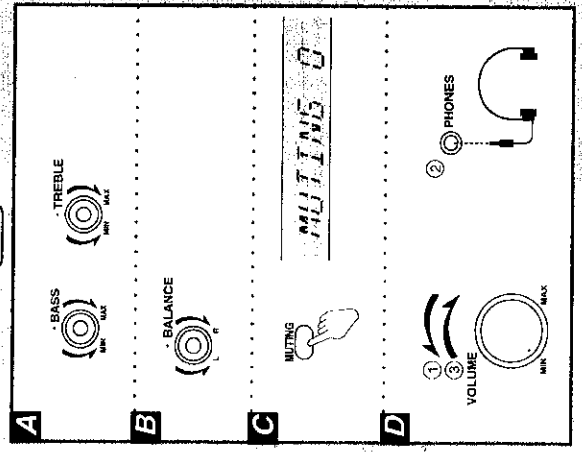

Making A Recording

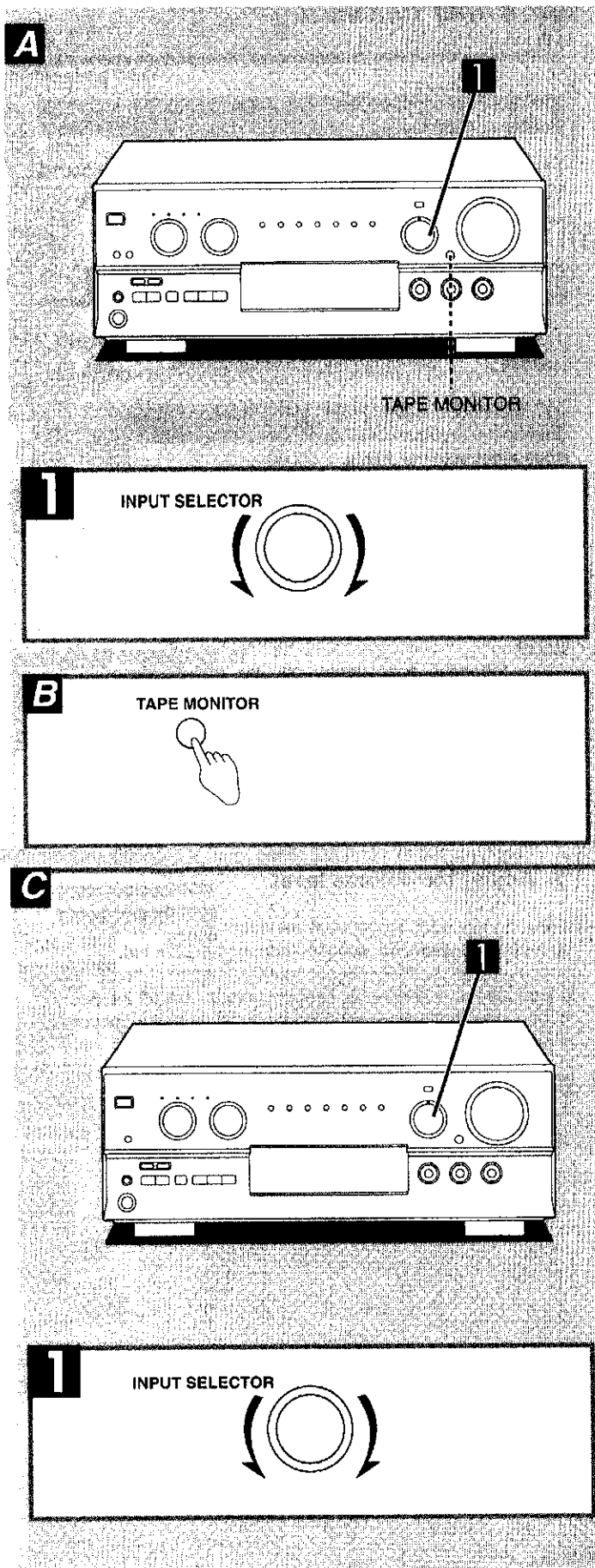

Recording on a tape deck A

Before recording, prepare the tape deck for recording. See the tape deck's operating instructions for details.

- 1 Turn [INPUT SELECTOR] to select the source to be recorded.**
Any source can be selected except TAPE.
- 2 Begin recording on the tape deck.**
Follow your tape deck's operating instructions.
- 3 Begin the source to be recorded.**
Follow your equipment's operating instructions.

To check the sound recorded while a recording is being made B

It is possible to check the sound being recorded if your tape deck is a 3 head system.

Press [TAPE MONITOR] on this unit and set the monitor button on the tape deck to "TAPE".

Press [TAPE MONITOR] once again to turn it off.

Recording on a VCR C

Before recording, prepare VCR for recording. See the VCR's operating instructions for details.

- 1 Turn [INPUT SELECTOR] to select the source to be recorded.**
Any source can be selected except VCR and TAPE.
- Note**
Recording from the tape deck is not possible.
- 2 Begin recording on the VCR.**
Follow your VCR's operating instructions.
 - 3 Begin the source to be recorded.**
Follow your equipment's operating instructions.

.....

Note

When you select DVD 6CH INPUT mode, only sound from the front left and right speakers is recorded.

To record all 6 channels
Set the playback mode on your DVD player or decoder to 2 channel (stereo) mode.

For details, see the instruction manual that came with the connected equipment.

Using the Remote Control

Point the remote control toward the receiver

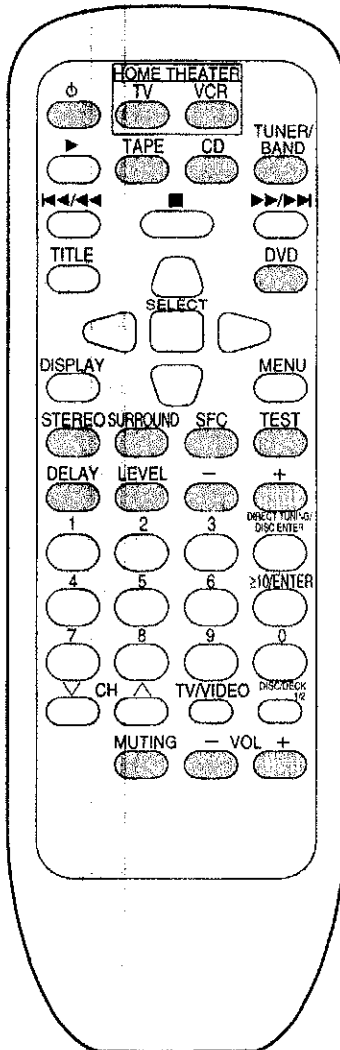

Basic operations

To turn the unit ON/OFF



Once the unit has been set to ON, it can be turned ON and OFF simply by pressing [⏻].

Note

After turning the TV, VCR or DVD player ON or OFF, always press TUNER/BAND before pressing [⏻] when turning the receiver ON and OFF.

To select an input source and switch the remote control transmitter to each operation mode

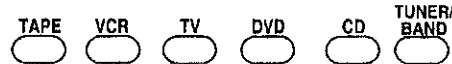

Note

PHONO can not be selected with this remote control.

To turn off the Dolby Pro Logic and SFC mode



To turn on the Dolby Pro Logic and select the SURROUND mode



Note

3 STEREO can not be selected with this remote control.

To turn on the SFC function and select the desired mode



Changes as follows each time the button is pressed.

HALL → CLUB → LIVE → THEATER
└─ SIM SURR (SIMULATED) ─┘

To output a test signal



When the SURROUND or 3 STEREO mode is ON

Press once more to stop the signal.

To adjust the output level of the center speaker and/or surround speakers



- ① Select center (C) or surround (S).
- ② Adjust output level.

When the SURROUND, 3 STEREO or SFC mode is ON

- When the SURROUND mode is ON and the center mode is on PHANTOM, you cannot select the center channel.
- When SFC is used, the center mode can be changed only if THEATER is on.
- When the 3 STEREO mode is ON, you cannot select the surround channel.

To adjust the delay time



When the SURROUND or SFC mode is ON

To mute the sound level



The message "MUTING ON NOW" runs repeatedly from right to left across the display as long as the muting function is on. Press once more to return to the original volume.

To adjust the volume level



■ Operation Checks

"ATTENTION SERVICER" Some chassis components may have sharp edges. Be careful when disassembling and servicing.

1. This section describes procedures for checking the operation of the major printed circuit boards and replacing the main components.
2. For reassembly after operation checks or replacement, reverse the respective procedures.
Special reassembly procedures are described only when required.
3. Select items from the following index when checks or replacement are required.

• Contents

	page
• Checking Procedure For Each Major P.C.B.	12 ~ 14
• Main Component Replacement Procedures	14 ~ 15

■ Checking Procedure For Each Major P.C.B.

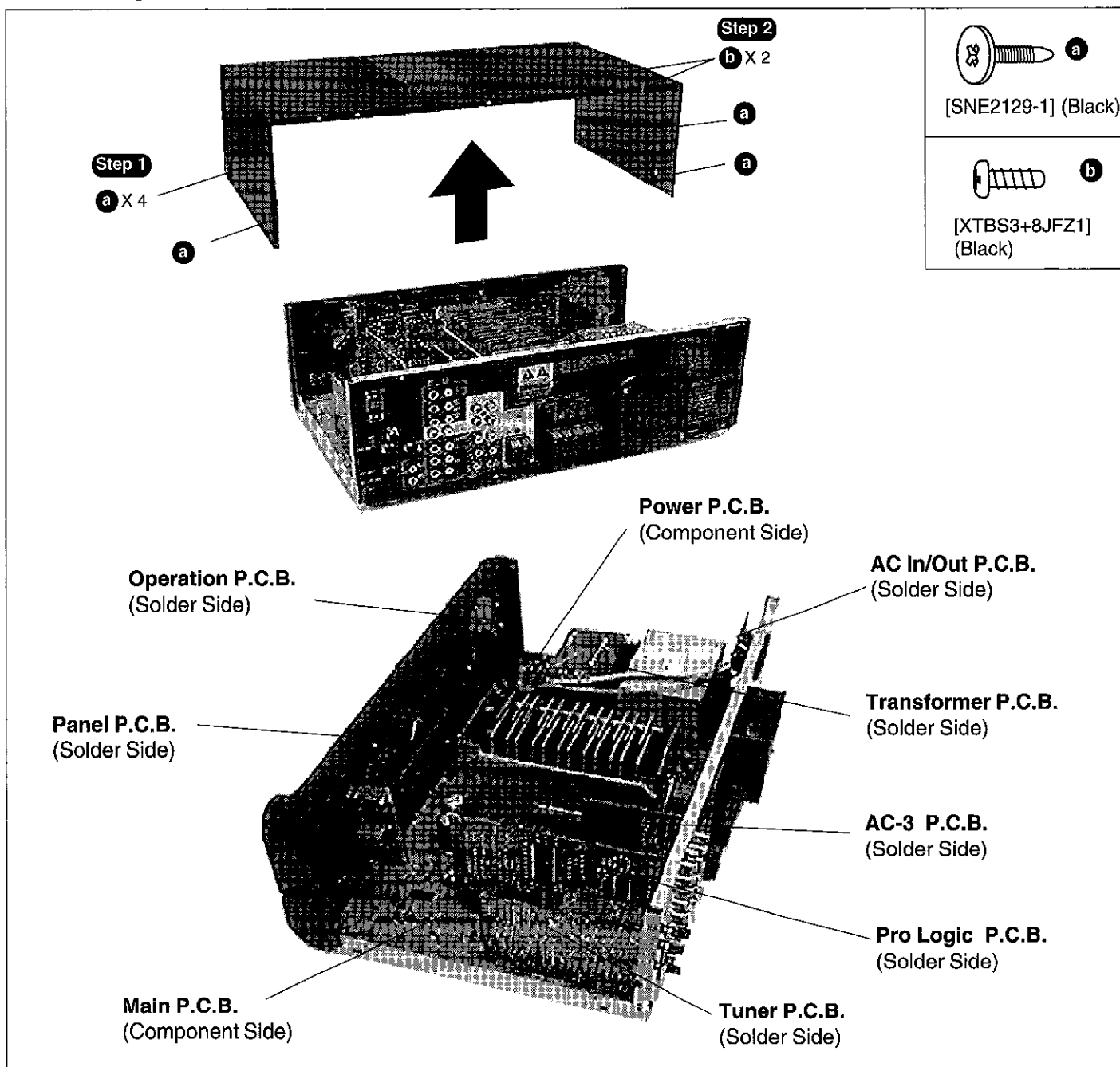

To remove Front Panel and check Panel P.C.B. , Operation P.C.B. and Headphone Jack P.C.B.

Step 1

Remove the top cabinet.

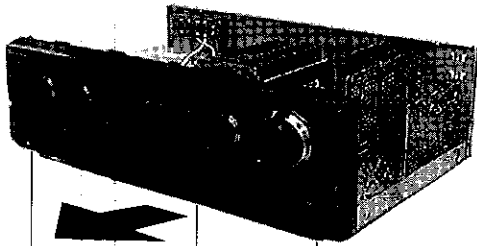

Step 2

b X 3

b

Step 3

Remove the Front Panel in the direction of arrow.

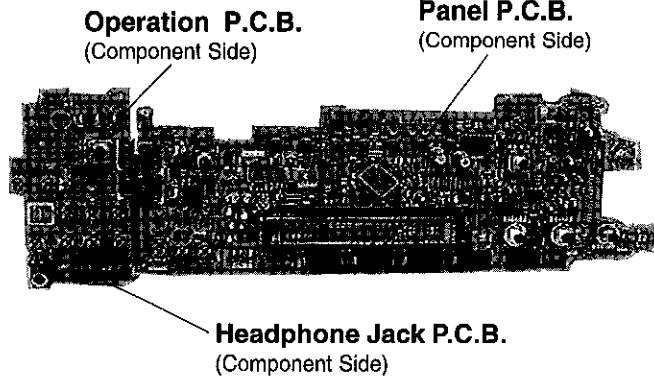

Step 4

Remove all Knobs and Nuts from Front Panel.

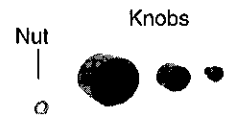

c X 13

Step 5

Step 6

d X 1

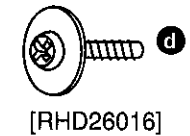
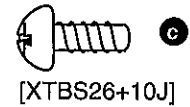

Step 7

Pull out the Headphone Jack P.C.B.

To remove Rear Panel and check Main P.C.B. and Power P.C.B.

Step 4

Release the AC In/Out P.C.B. catches and the fan motor connector, then pull out the rear panel in the direction of arrow.

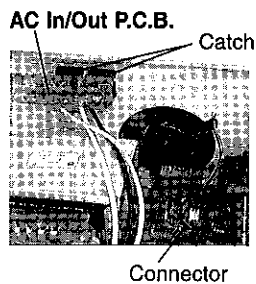

Step 1

Remove the top cabinet.

Step 2

Remove the front panel.

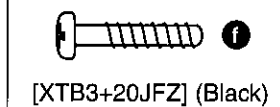
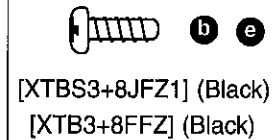

Step 5

f X 12

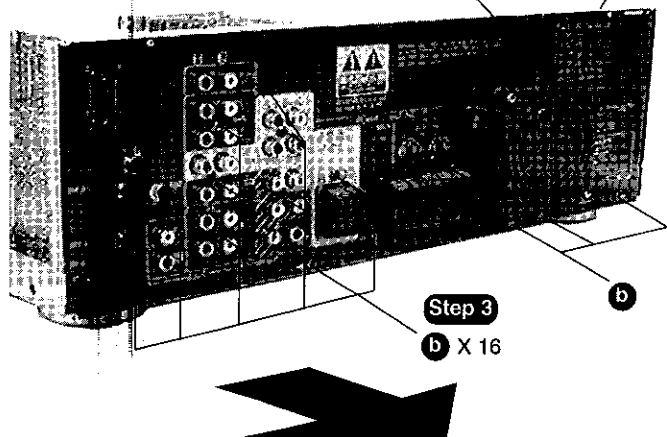

Step 3

b X 16

Step 6

e X 2

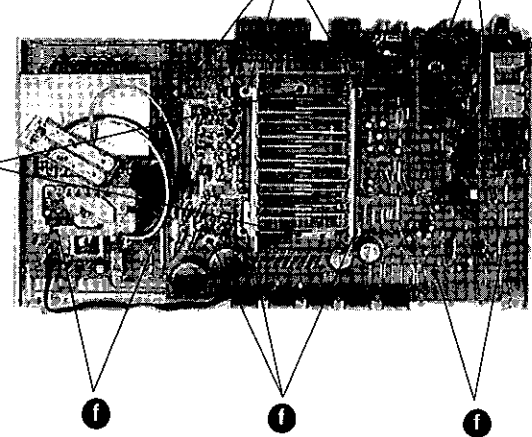

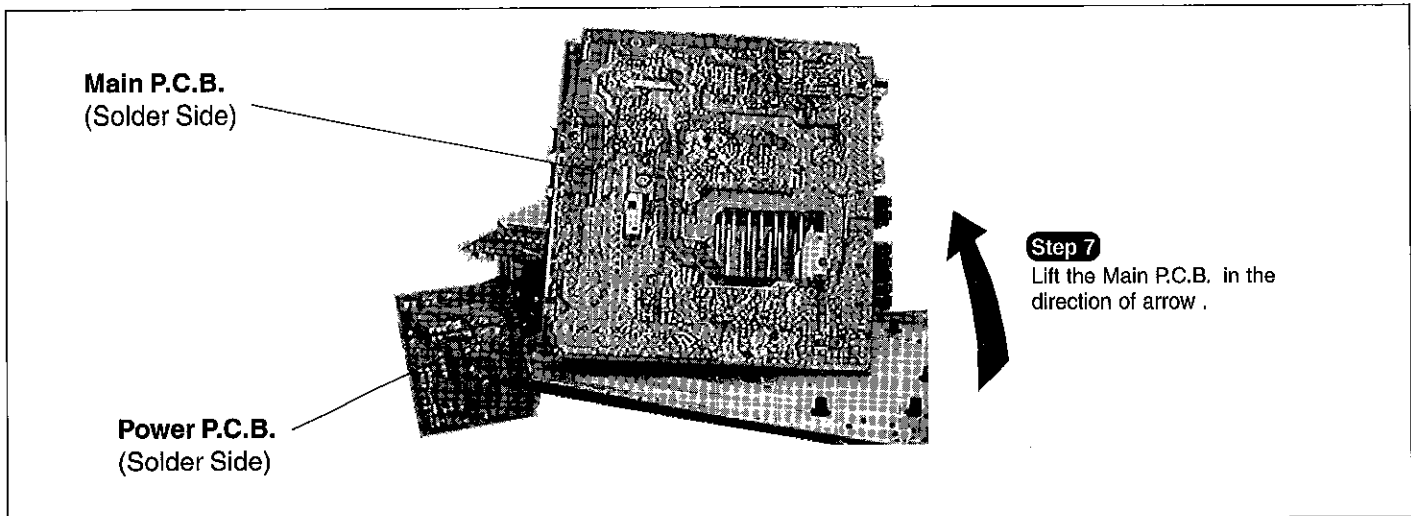

■ Main Component Replacement Procedures

1. Replacement of the Power IC and Regulator Transistor

Step 1

Remove the top cabinet.

Step 2

Cut the joints as shown below. (8 joints)

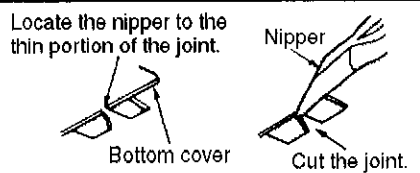

Step 3

Fold the joints. (8 joints)

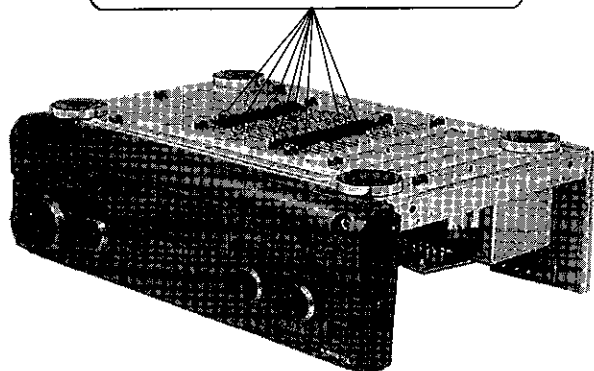
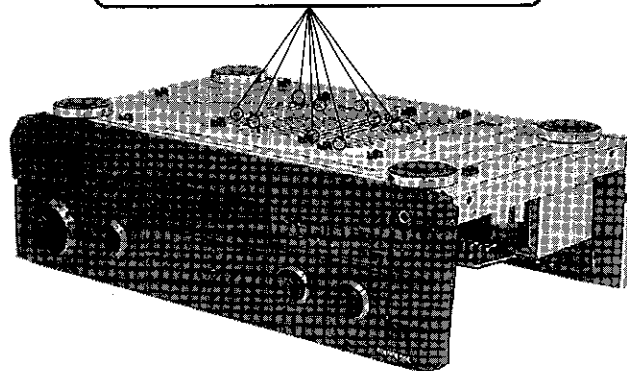
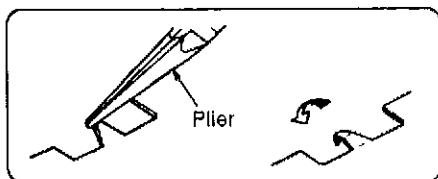

Step 4

Desolder the terminals of Power IC and Regulator Transistor.

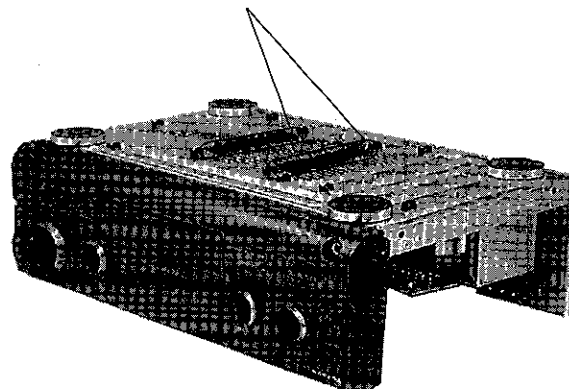

Step 5

Remove all screws (b) for the Tuner, AC-3 and Pro Logic P.C.B.'s at the Rear Panel and pull out these P.C.B.'s from the Main P.C.B.

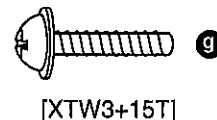
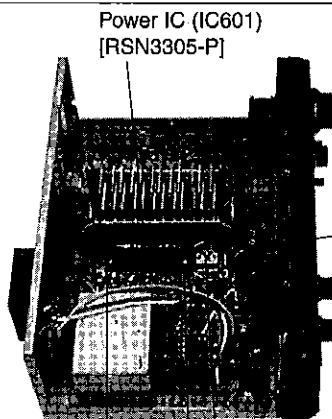
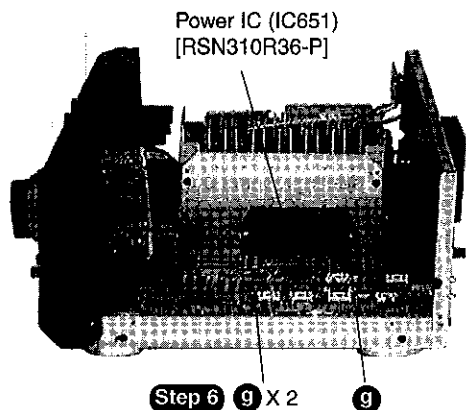

Regulator transistor (Q701, Q708) [2SD2374PQAU, 2SB1548PQAU]

Step 7

(g) X 3



•The PROTO Offset Screwdriver No. 34-1/4 is recommended for use in the application above.

Installation of the bottom cover after replacement

Step 1

Flip over the bottom cover

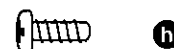

[XTB3+8J] (Black)

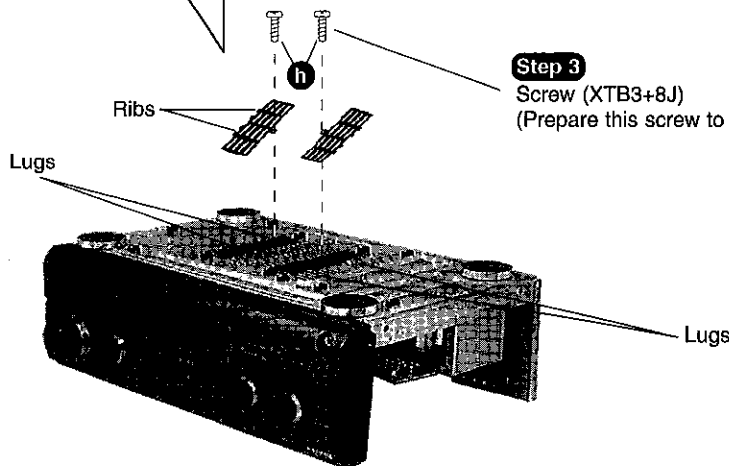

Step 2

Align the ribs of bottom cover into the lugs.

Step 3

Screw (XTB3+8J) (Prepare this screw to fix the bottom cover.)

CAUTION

1. After replacing the power IC or regulator transistor, apply a sufficient quantity of compound grease (RFKX0002/SZZ0L15) between the heat sink and the power IC or regulator transistor (Radiation of power IC).
2. Tighten enough the screws (g) after replacing the power IC and regulator transistor. Otherwise, the heat radiation works little.
3. When installing or removing the power IC or transistor holder, be sure to use an offset screwdriver.

- A long straight screwdriver cannot be used for removing or mounting the screws since its long grip interferes with the neighbouring P.C.B. (See Fig.1)
- A short straight screwdriver may be used for removal, but cannot be used for mounting because the limited space in the unit will not allow sufficient tightening torque.(See Fig.2)

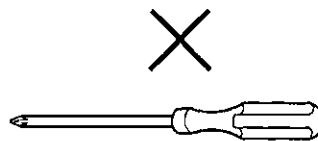

A long straight screwdriver

Fig.1

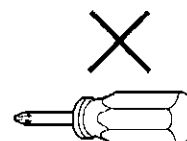

A short straight screwdriver

Fig.2

- Insufficient tightening will cause poor heat dissipation from the power IC and regulator transistor and, in the worst case, may lead to their thermal breakdown.

■ Terminal Functions Of ICs

• IC901 (M38B57M6120F) System Microprocessor

Pin No.	Mark	I/O	Function	Pin No.	Mark	I/O	Function
1~2	KEY2~KEY1	I	Key Input 1 ~ 2	30	SP_B	O	Speaker B control output
3	THERM/OVLD	I	Thermal/Over load input	31	SP_A	O	Speaker A control output
4	KEY4	I	Key Input 4	32	AF_MUTE	O	Muting control output
5	OVERLOAD2	I	Over load input 2	33~48	SEG16~SEG1	O	FL segment signal output
6	FMST	I	Stereo signal detect terminal	49~58	DEG1~DEG10	O	FL digit signal output
7	WAKE	-	Wake up timer LED	59	INIT_IN	I	Diode input initial settings
8	RDS_DI	-	Control of RDS IC (Not used,open)	60	VOL_DOWN	O	Volume control output (Down)
9	REMOTE	I	Remote control terminal	61	VOL_UP	O	Volume control output (Up)
10	RESET	I	Reset detect terminal	62	REC_MUTE	O	REC Mute control
11	RDS_CK	-	Control of RDS IC (CK) clock signal	63	IF_DATA	I	Serial data signal
12	RDS_DT	-	Control of RDS IC (DT) data signal	64	LIMITTER	O	Power limiter control output
13	GND	-	GND terminal	65	TNR_CE	O	Tuner control (CE) chip enable signal
14	XIN	I	Crystal oscillator terminal (4 MHz)	66	SEL/TNR_CK	O	Selector/Tuner (CK) clock signal
15	XOUT	O	Crystal oscillator terminal (4 MHz)	67	SEL/TNR_DT	O	Selector/Tuner (DT) data signal
16	VDD (+5V)	-	Power supply terminal +5V	68	SEL_ST	O	Selector control terminal
17	LED_CK	O	LED driver IC (CK) clock signal	69	MMD	O	MMD control terminal
18	LED_DATA	O	LED driver IC (DT) data signal	70	SURR/OSD_CK	O	Surround control (CK) clock signal
19	SFC1	I	SFC mode encoder input 1	71	SURR/OSD_DT	O	Surround control (DT) data signal
20	SFC2	I	SFC mode encoder input 2	72	SURR_CE	O	Surround control (CE) chip enable signal
21	SEL1	I	Selector encoder for input 1	73	AVSS	-	GND for A-D converter
22	HOLD	I	Blackout detection terminal	74	VREF	-	Reference voltage for A-D converter
23	SEL2	I	Selector encoder for input 2	75	SD	I	SD signal detect input
24	TV_VCR2	I	TV-VCR2 control input	76	SUR1	I	Encoder of surround mode selector input1
25	RLY	-	Relay control output	77	HELP_LED/RDS_CE	O	Help LED control output
26	LOUDNESS	O	Loudness control output	78	SUR2	I	Encoder of surround mode selector input2
27	6CH_ST	O	6 ch sw control output (ST)	79	VIDEO_B	O	Video selector control output B
28	VEE	-	Power supply for FL driver	80	VIDEO_A	O	Video selector control output A
29	S/C_SP	O	Surround/Center speaker control output				

■ Type Illustration of ICs, Transistors and Diodes

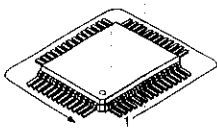
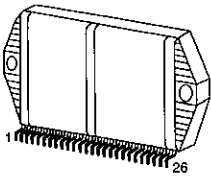
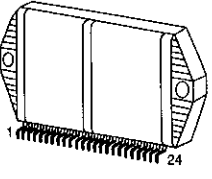
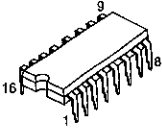
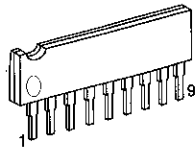
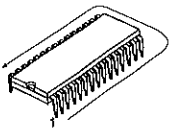
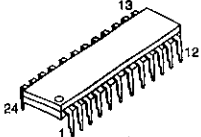
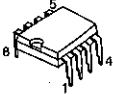
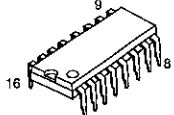
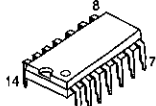
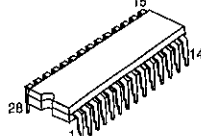
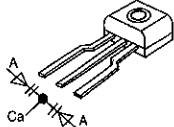
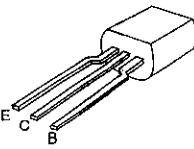
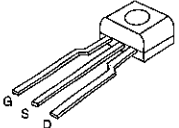
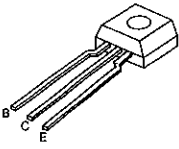
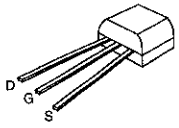
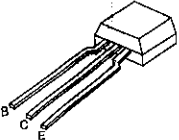
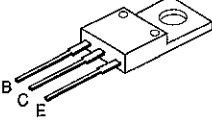
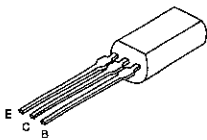
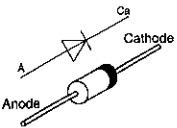
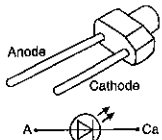
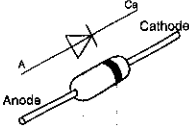
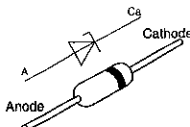
<p>M38B57M120F (80p)</p> 	<p>RSN3305-P</p> 	<p>RSN310R36-P</p> 	<p>TC9214AP</p> 	<p>BA6218</p> 	<p>LA2786L</p> 
<p>LA1832A LC7218 LV1016L</p> 	<p>AN6558F UPC4570C</p> 	<p>BU2090A</p> 	<p>NJM2060D NJM2279D</p> 	<p>TC9162AN TC9163AN</p> 	<p>SVC211SPA-AL</p> 
<p>2SB621AQSTA 2SD592AQSTA</p> 	<p>2SK544F-AC</p> 		<p>2SC2787LTA 2SC2786MTA 2SC2787FL1TA 2SC2785FETA 2SC3311ARTA 2SD1915FTA</p>	<p>2SK2880CTA</p> 	
<p>2SA933SSTA 2SC1740SSTA</p> 	<p>RVTDTA113ZST RVTDTA114EST RVTDTA143XST RVTDTC114EST RVTDTC114TST RVTDTC114YST RVTDTC143XST</p>	<p>2SB1548PQAU 2SD2374PQAU</p> 	<p>2SA1534AQRTA 2SC3940AQSTA</p> 	<p>1N5402BM21 RK306LFU1</p> 	<p>SLR325MCT31 SLR325VCT31</p> 
 <p>1SS291TA RVD1SS133TA MA700ATA MA167TA 1SR35200TB</p>	 <p>MTZJ10CTA MTZJ11CTA MTZJ15CTA MTZJ18CTA MTZJ27DTA MTZJ3R9ATA MTZJ4R3BTA</p>	<p>MTZJ4R7BTA MTZJ5R1BTA MTZJ5R6BTA MTZJ6R2BTA MTZJ6R8BTA MTZJ7R5CTA</p>			

Wiring Connection Diagram

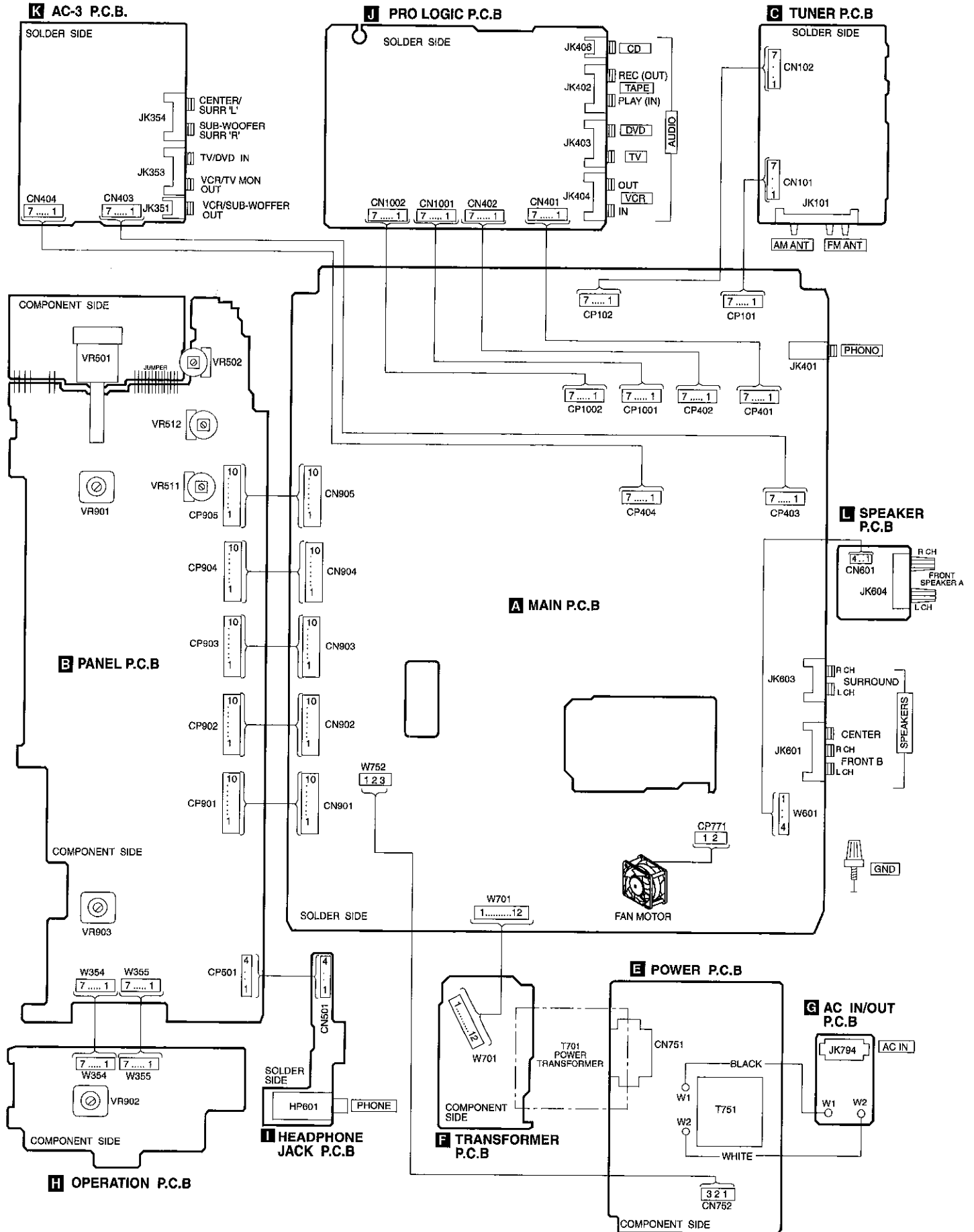

Block Diagram

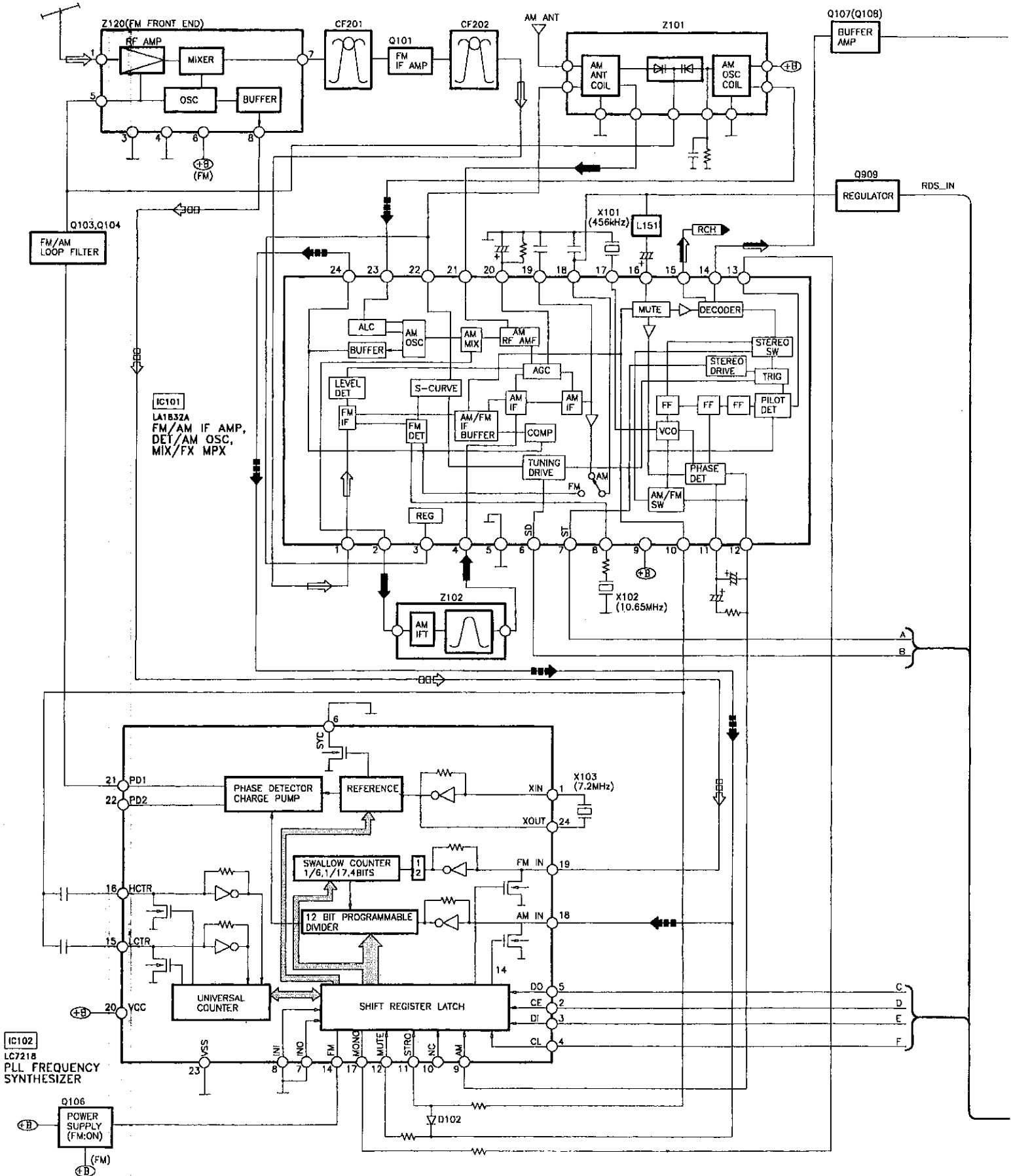

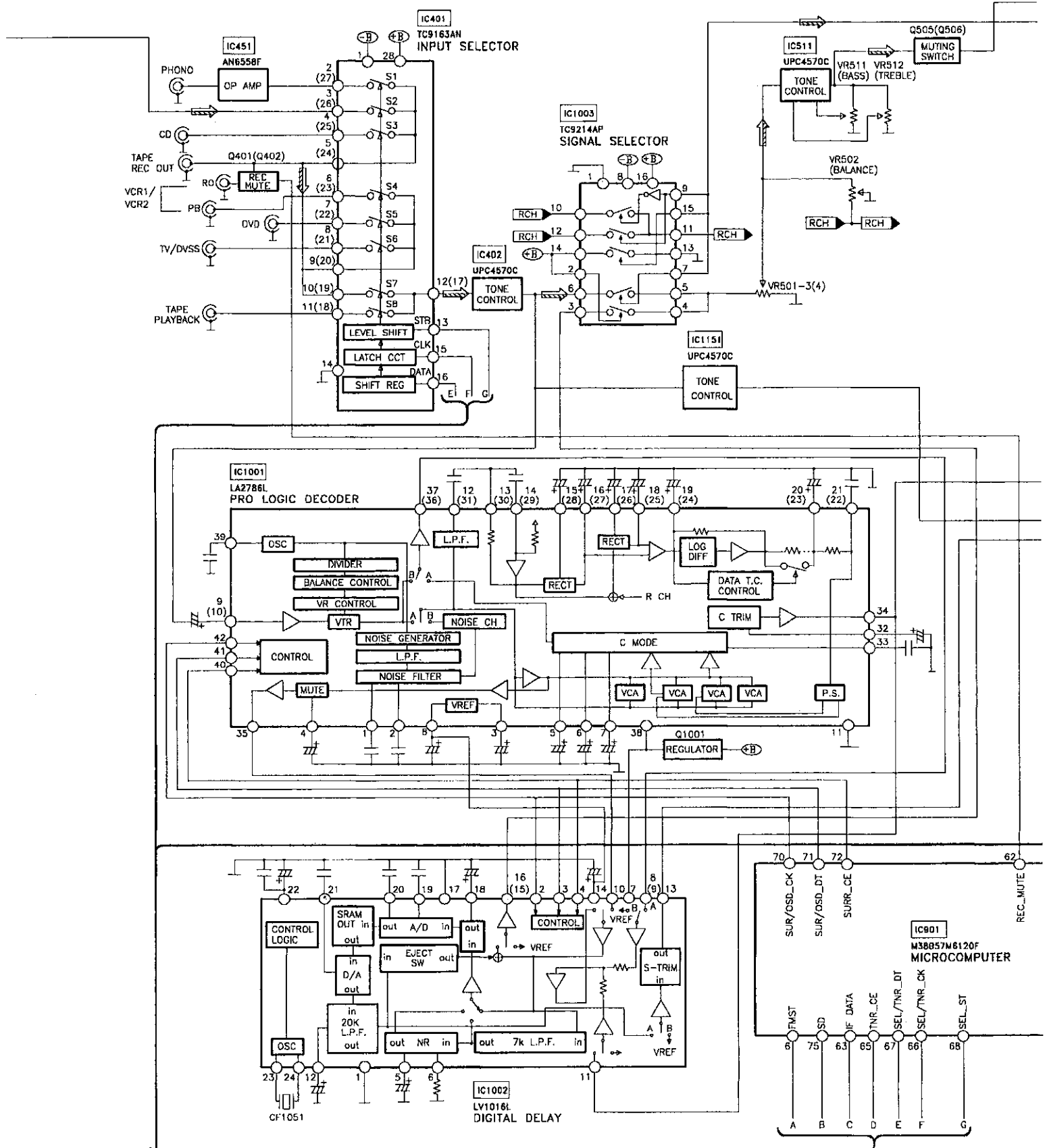

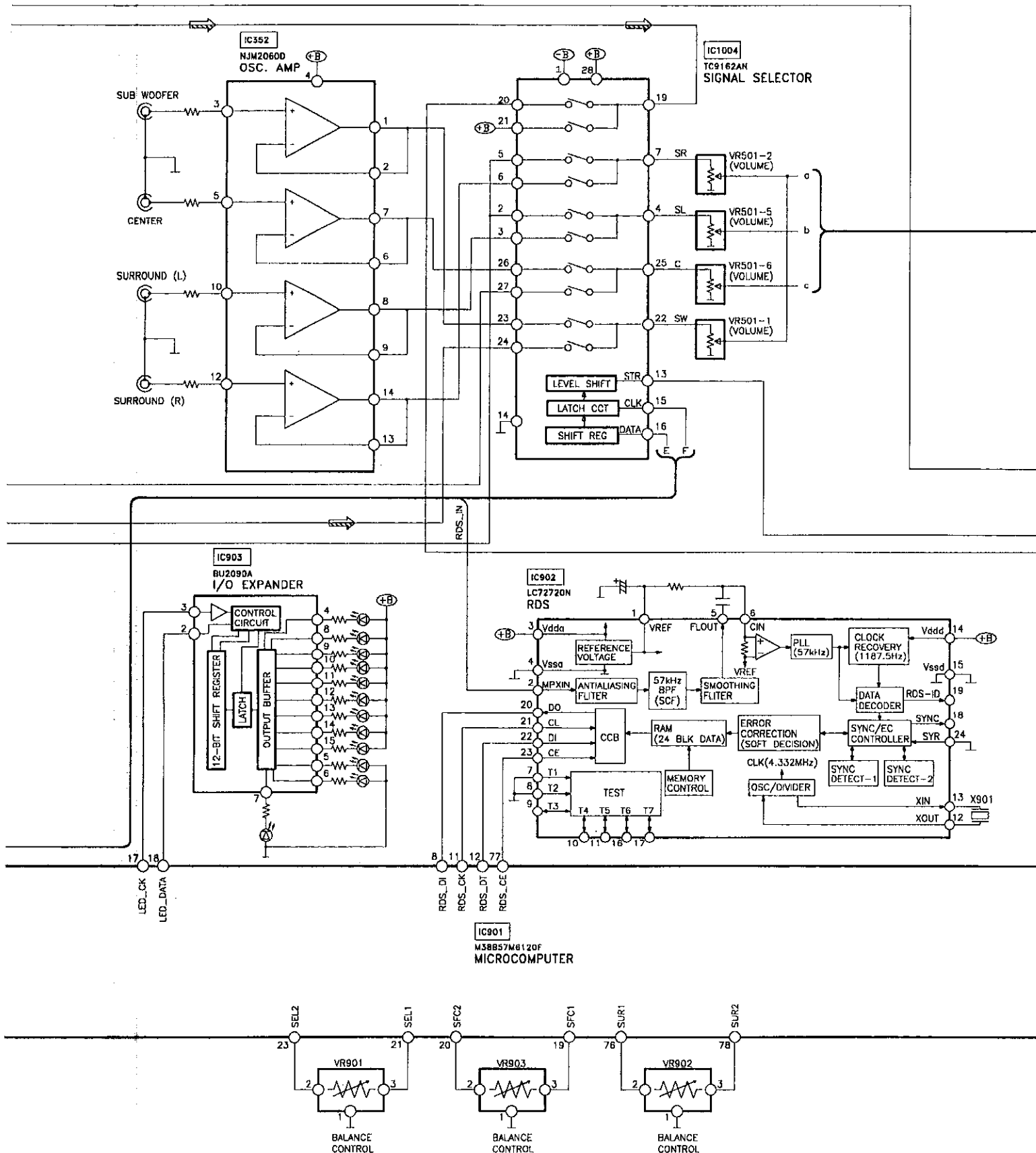

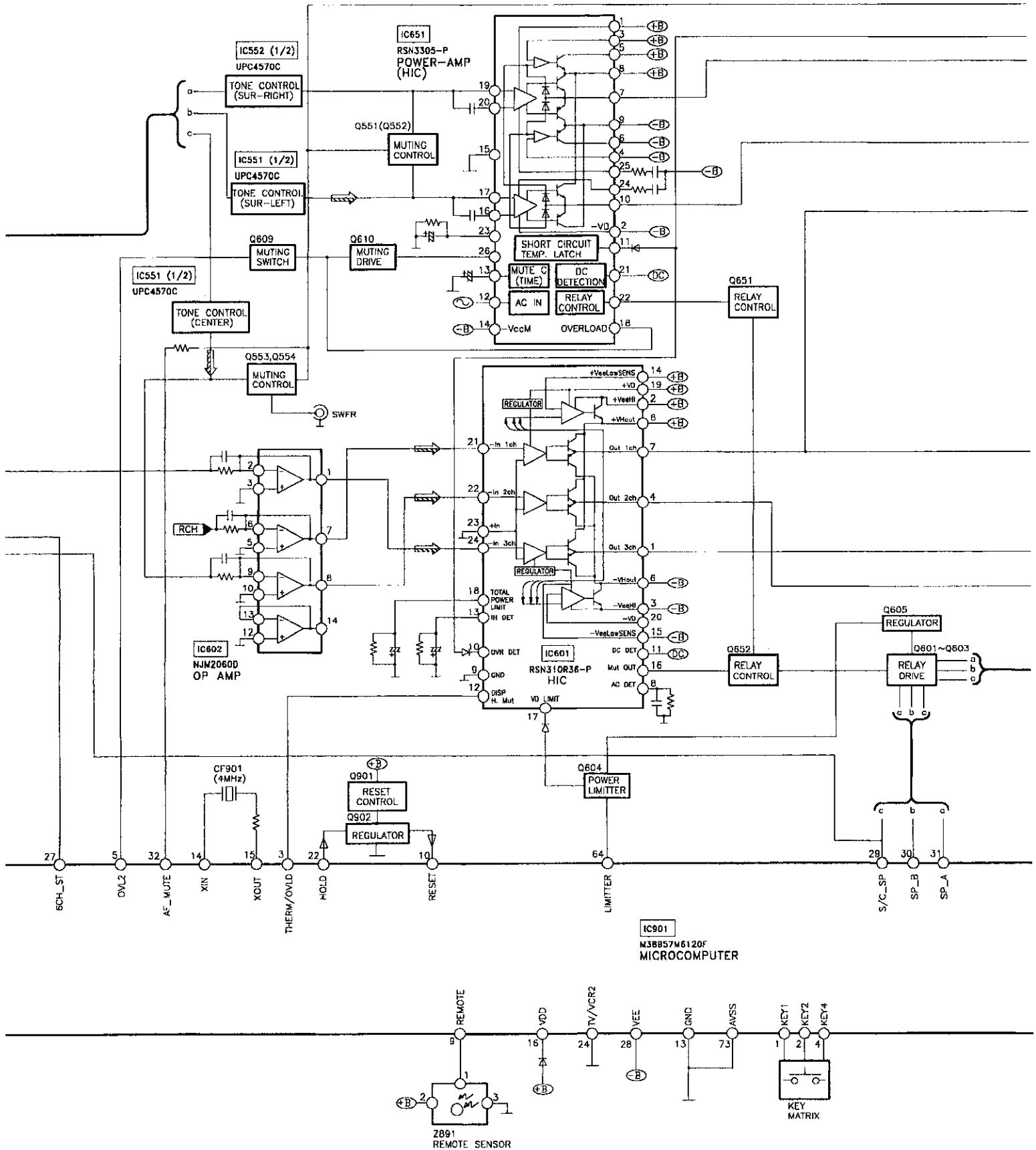

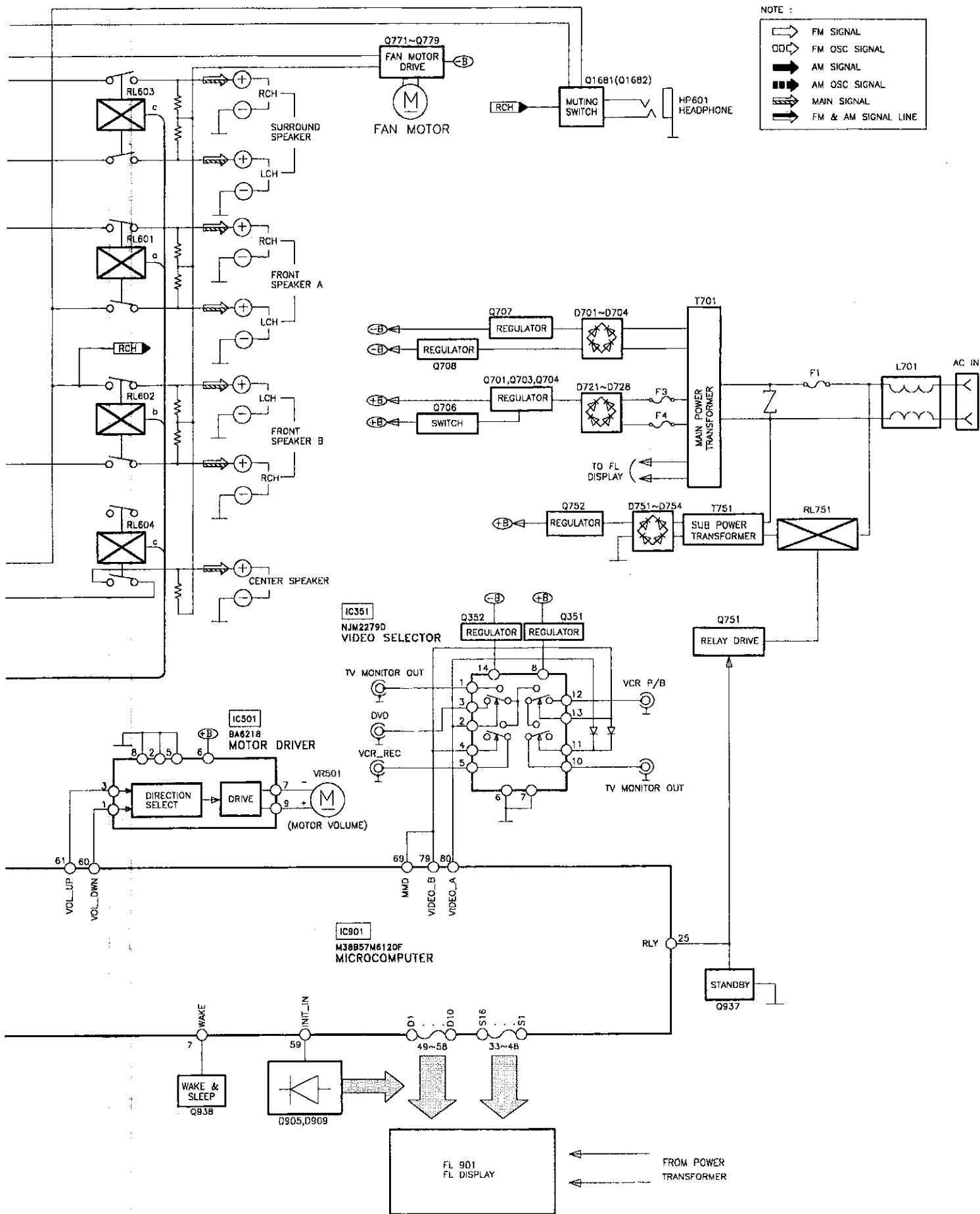

Schematic Diagram

	Page		Page
A MAIN CIRCUIT	25 ~ 29	H OPERATION CIRCUIT	40
B PANEL CIRCUIT	30 ~ 33	I HEADPHONE JACK CIRCUIT	40
C TUNER CIRCUIT	38 ~ 39	J PRO LOGIC CIRCUIT	34 ~ 36
E POWER CIRCUIT	40	K AC-3 CIRCUIT	37
F TRANSFORMER CIRCUIT	40	L SPEAKER CIRCUIT	37
G AC IN/OUT CIRCUIT	40		

(All schematic diagrams may be modified at any time with the development of new technology)

Note :

- | | |
|------------------------------------|---------------------------------------|
| • S946 : Power switch | • S976 : DVD 6Ch switch |
| • S948 : Muting switch | • S980 : Speaker A select switch |
| • S950 : FM mode switch | • S981 : Speaker B select switch |
| • S951 : Band select switch | • S985 : Center mode select switch |
| • S952 : Tuning decrease switch | • S986 : Delay time switch |
| • S953 : Tuning increase switch | |
| • S954 : Timer switch | • VR501 : Volume control |
| • S955 : Memory switch | • VR502 : Balance control |
| • S956 : Tuning mode preset switch | • VR511 : Bass control |
| • S958 : Help / Reset switch | • VR512 : Treble control |
| • S970 : Search switch | • VR901 : Input selector knob |
| • S971 : Eon switch | • VR902 : Dolby Pro-logic select knob |
| • S974 : Display switch | • VR903 : Mode SFC on/off knob |

• Signal line

	: +B Line		: Main Signal Line
	: -B Line		: FM Signal Line
	: FM/AM Signal Line		: FM OSC Signal Line
	: AM Signal Line		
	: AM OSC Signal Line		

- The voltage value and waveforms are the reference voltage of this unit measured by DC electronic voltmeter (high impedance) and oscilloscope on the basis of chassis. Accordingly, there may arise some error in voltage values and waveforms depending upon the internal impedance of the tester or the measuring unit.

< > : FM

• Importance safety notice:

Components identified by  mark have special characteristics important for safety. Furthermore, special parts which have purposes of fire-retardant (resistors), high-quality sound (capacitors), low-noise (resistors), etc. are used. When replacing any of components, be sure to use only manufacturer's specified parts shown in the parts list.

Caution !

IC, LSI and VLSI are sensitive to static electricity.

Secondary trouble can be prevented by taking care during repair.

- Cover the parts boxes made of plastics with aluminium foil.
- Ground the soldering iron.
- Do not touch the pins of IC, LSI or VLSI with fingers directly.
- Put a conductive mat on the work table.

HEMATIC DIAGRAM - 1

A MAIN CIRCUIT
(P.C.BOARD ON PAGE 42)

— : +B line \Rightarrow : FM/AM signal line \Rightarrow : Main signal line

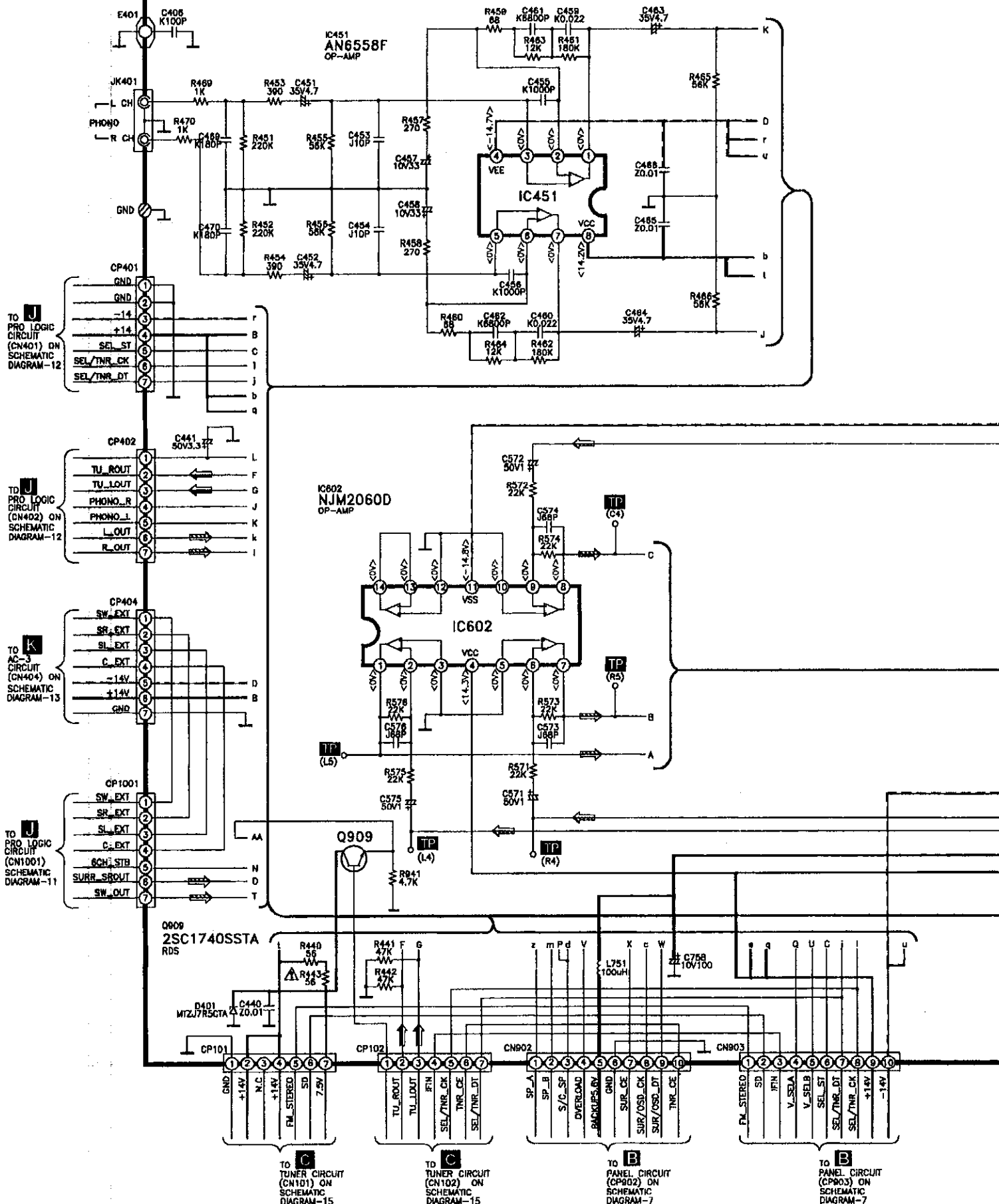

— : +B line - - - : -B line \Rightarrow : Main signal line

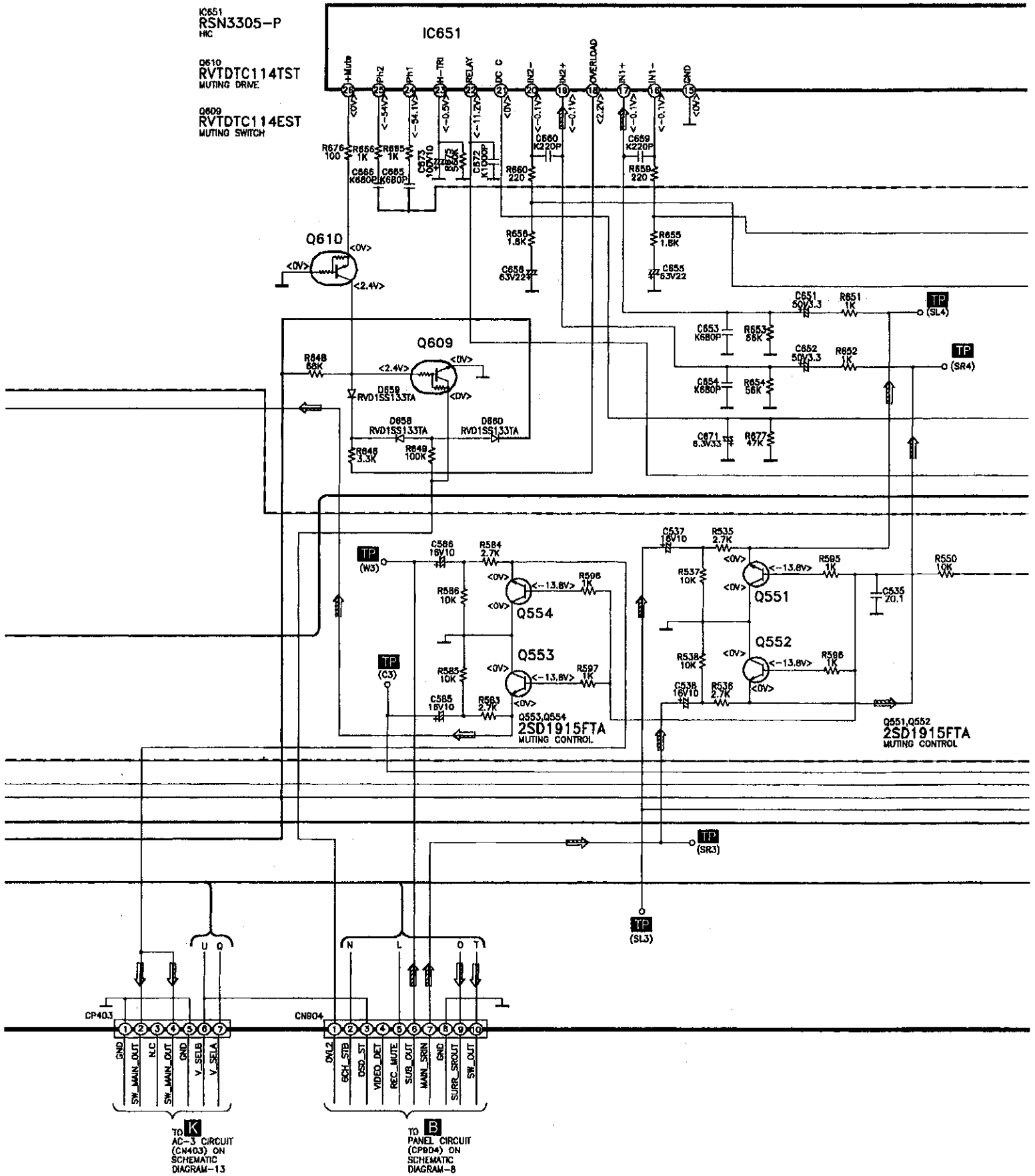

SCHEMATIC DIAGRAM - 3

— : +B line - - - : -B line \Rightarrow : Main signal line

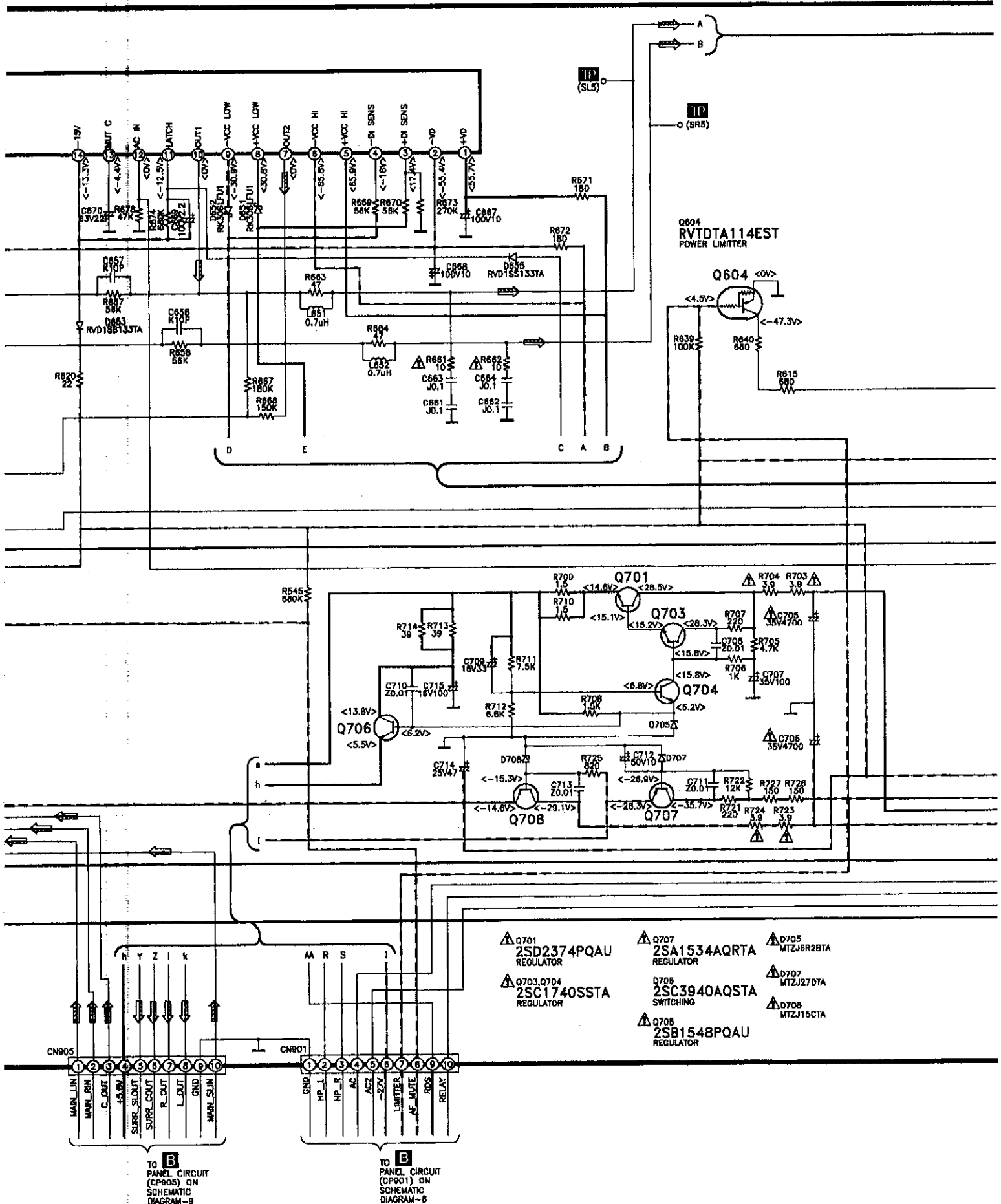

— : +B line - - - : -B line ⇨ : Main signal line

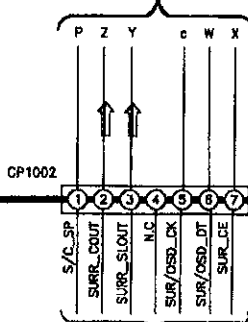
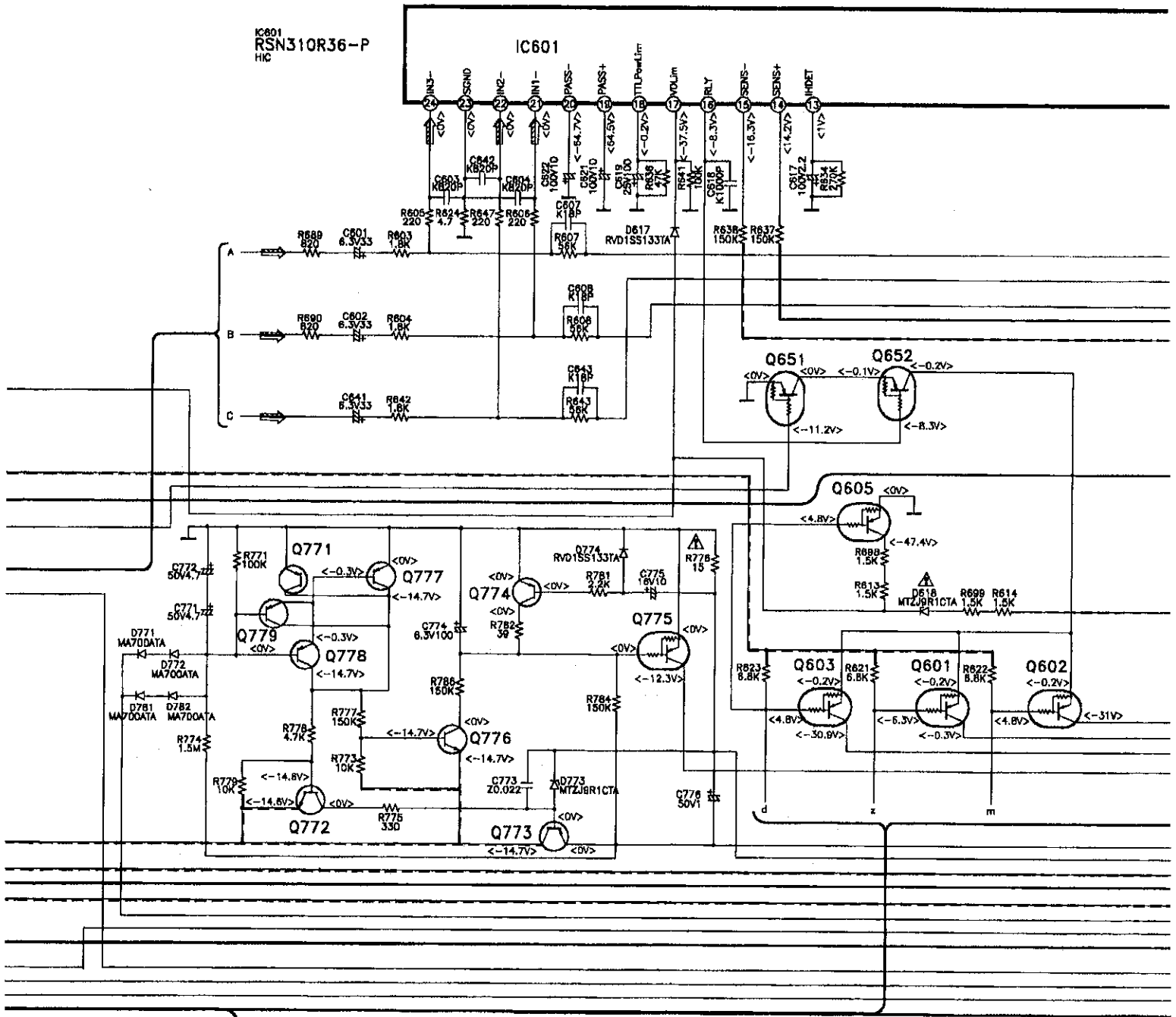

- | | | |
|---|---|--|
| Q603
RVTDTA143XST
RELAY DRIVE | Q651, Q652
RVTDTA143XST
RELAY CONTROL | Q774
RVTDTA113ZST
FAN MOTOR DRIVE |
| Q609
RVTDTA114EST
REGULATOR | Q772
2SC1740SSTA
FAN MOTOR DRIVE | Q771, 777
2SA933SSTA
FAN MOTOR DRIVE |
| Q601, Q602
RVTDTA143XST
RELAY DRIVE | Q773
2SB621AQSTA
FAN MOTOR DRIVE | Q775
RVTDTA114EST
FAN MOTOR DRIVE |
| | Q778
2SC1740SSTA
FAN MOTOR DRIVE | Q778, 779
2SA933SSTA
FAN MOTOR DRIVE |

TO
PRO LOGIC CIRCUIT
(CN1002) ON
SCHEMATIC
DIAGRAM-11

HEMATIC DIAGRAM - 5

— : +B line - - - : -B line \Rightarrow : Main signal line

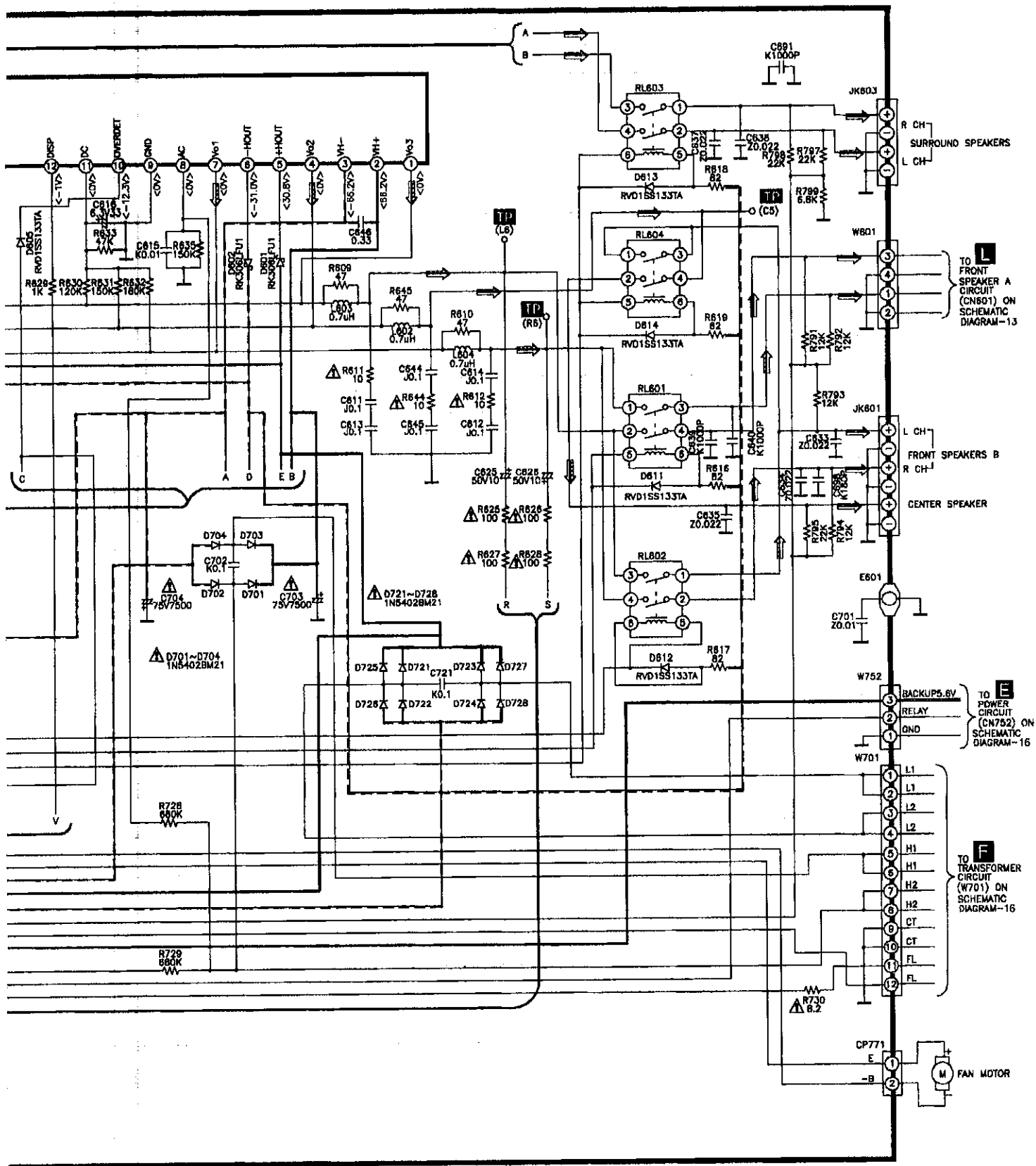

SCHEMATIC DIAGRAM - 6

B PANEL CIRCUIT (P.C.BOARD ON PAGE 44)

— : +B line - - - : -B line

A
TO MAIN
CIRCUIT
(CN001) ON
SCHEMATIC
DIAGRAM-3

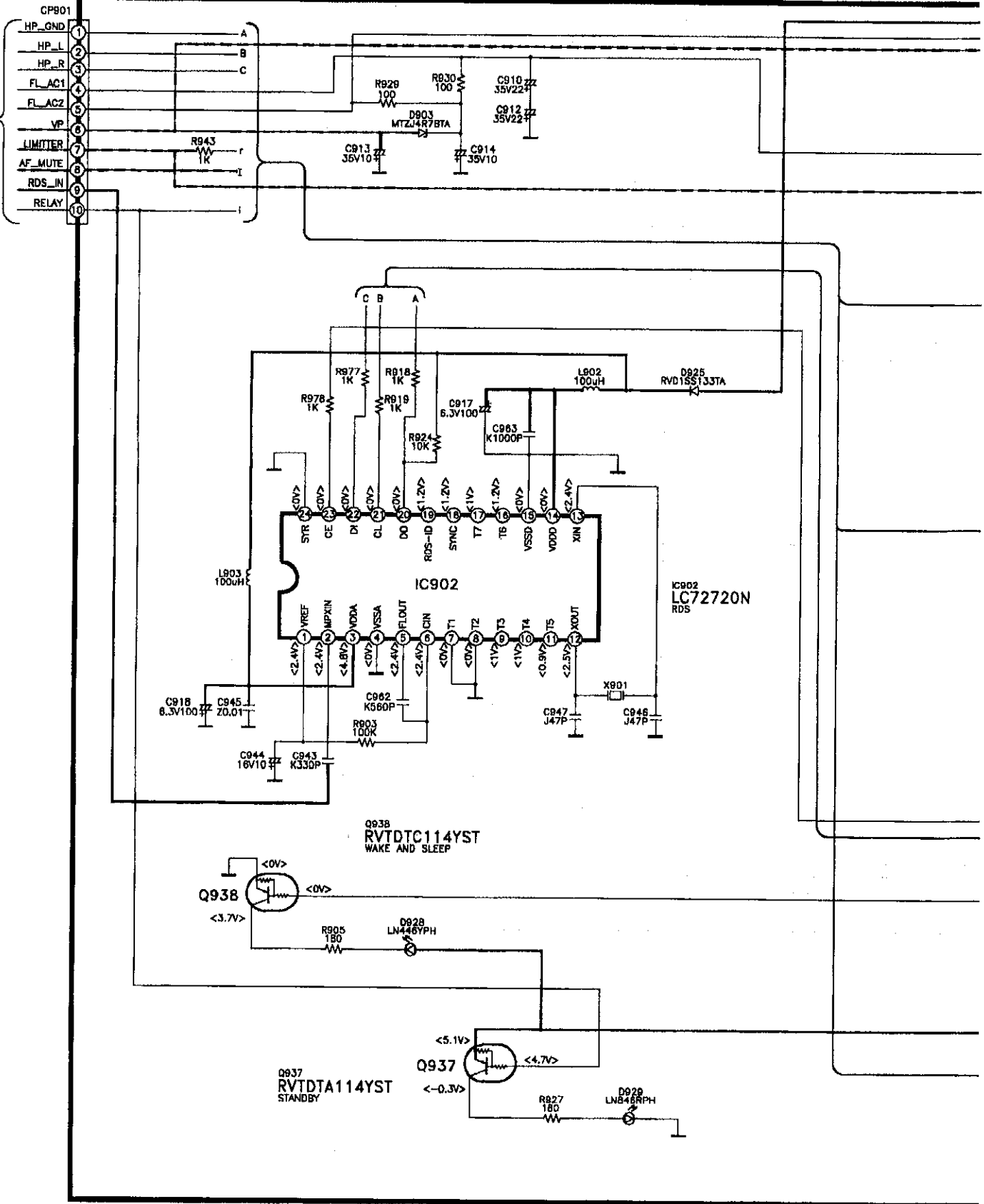

HEMATIC DIAGRAM - 7

— : +B line - - - : -B line

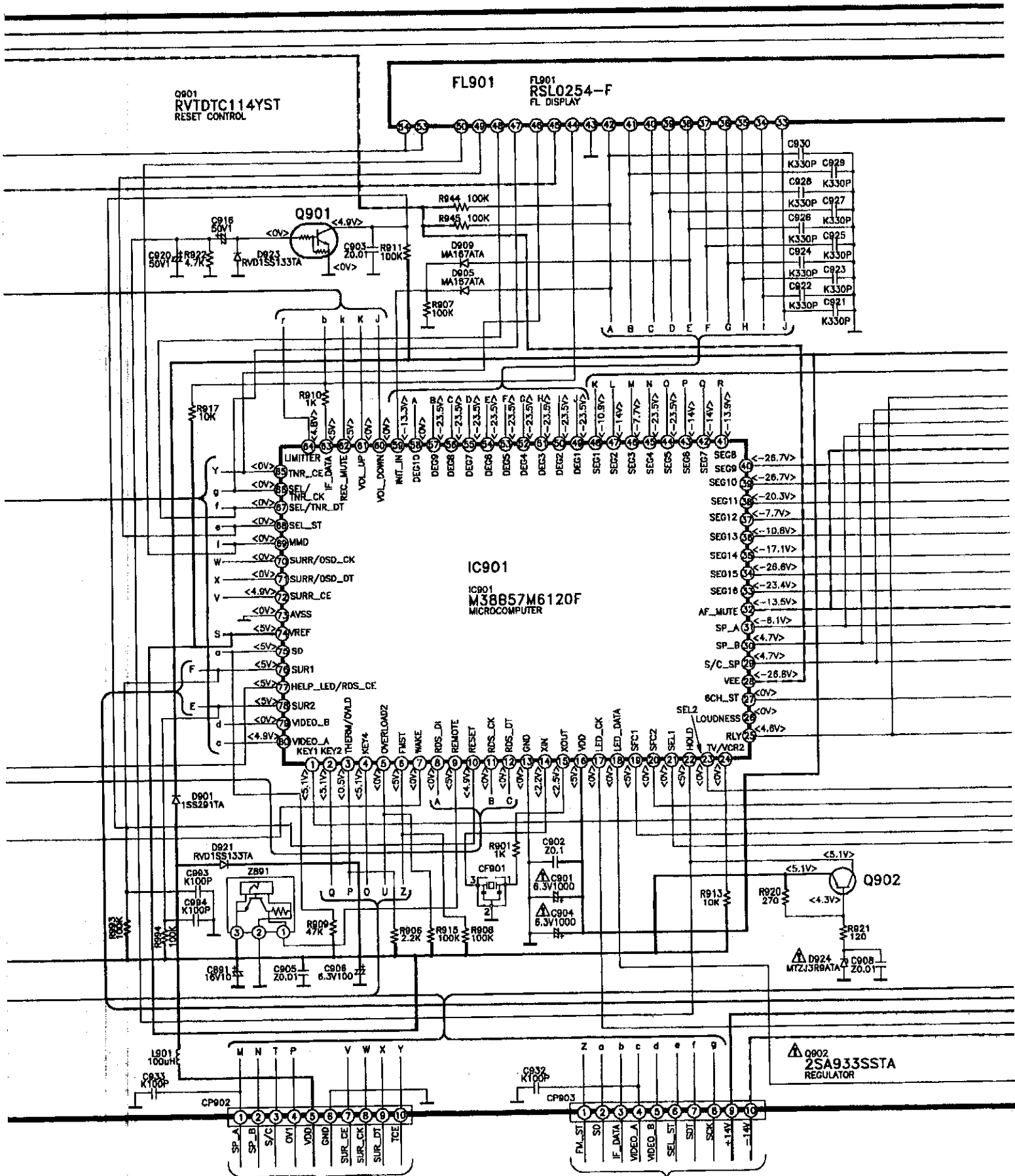

SCHEMATIC DIAGRAM - 8

— : +B line - - - : -B line ⇨ : Main signal line

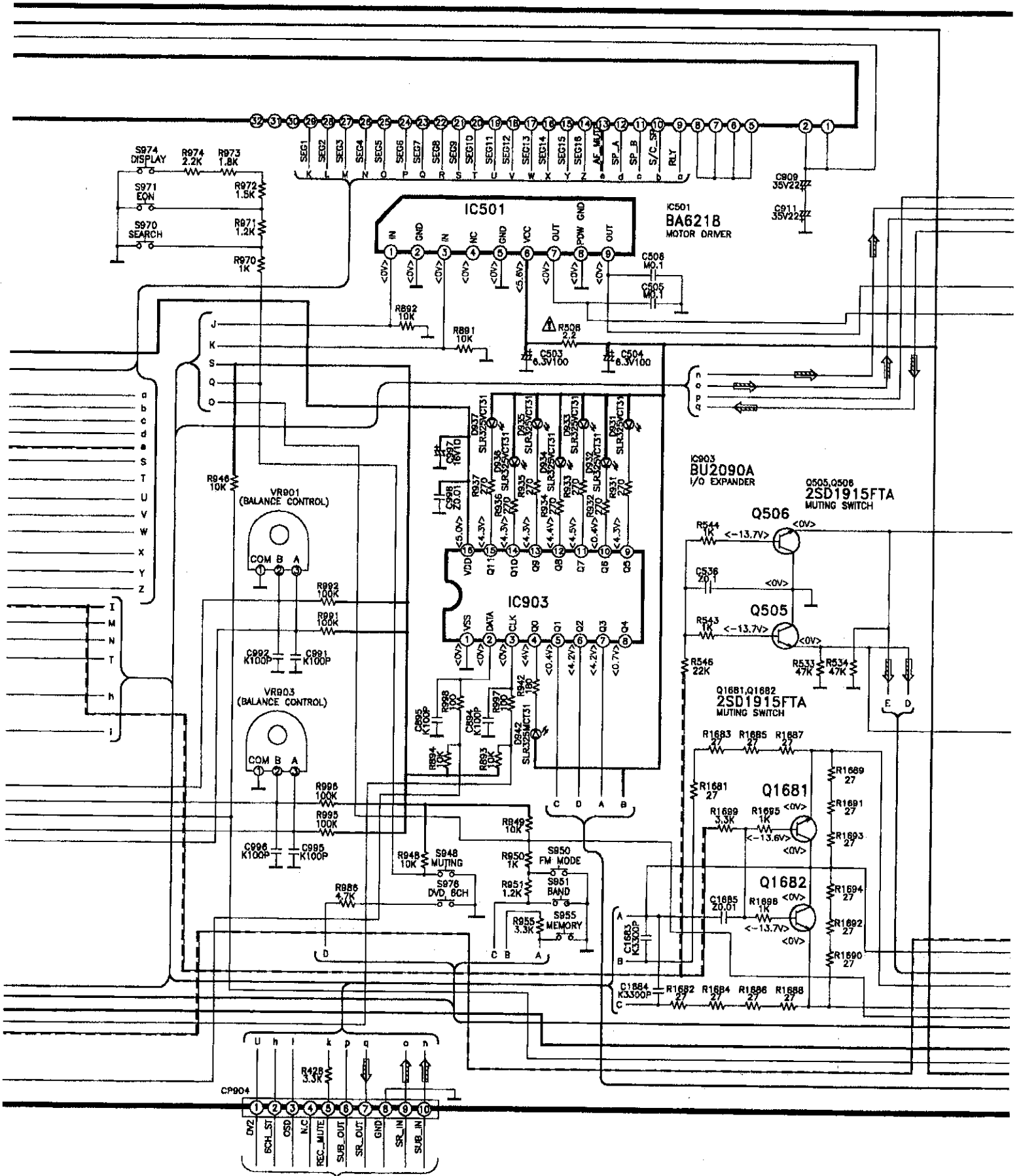

TO MAIN CIRCUIT (CN904) ON SCHEMATIC DIAGRAM-2

EMATIC DIAGRAM-9

— : +B line - - - : -B line ⇨ : Main signal line

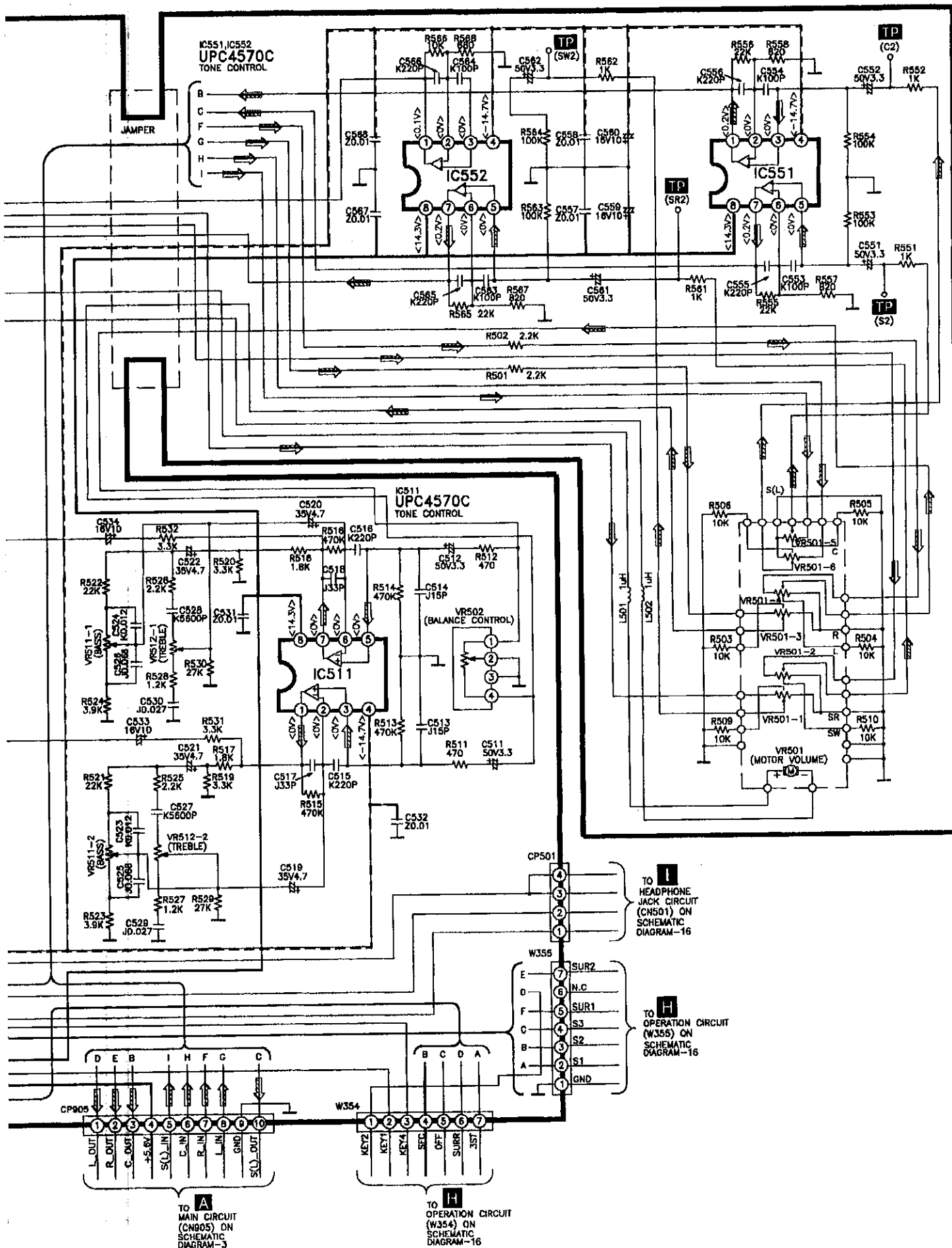

J PRO LOGIC CIRCUIT
(P.C.BOARD ON PAGE 41)

— : +B line

⇨ : Main signal line

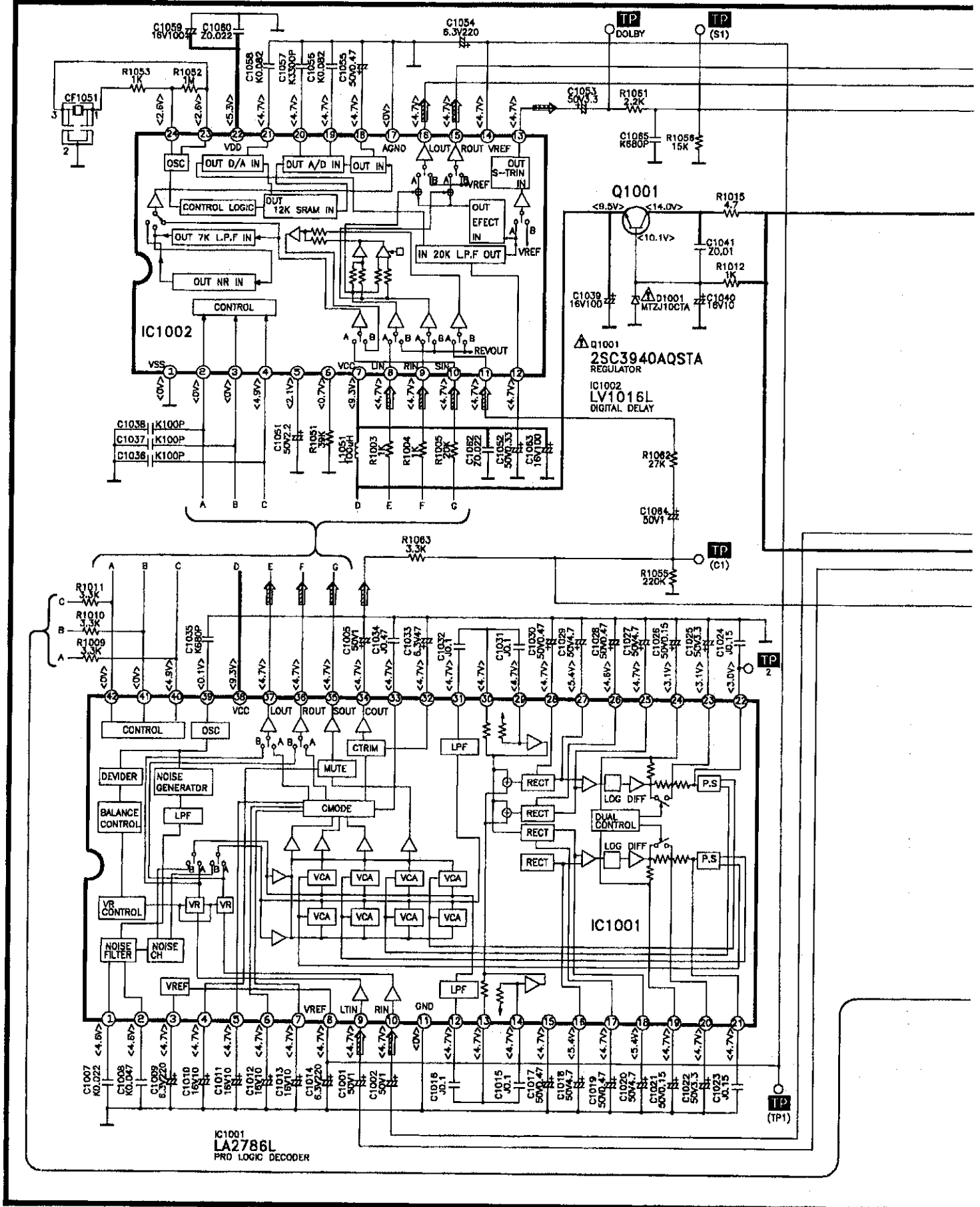

SCHEMATIC DIAGRAM - 11

— : +B line - - - : -B line \Rightarrow : Main signal line

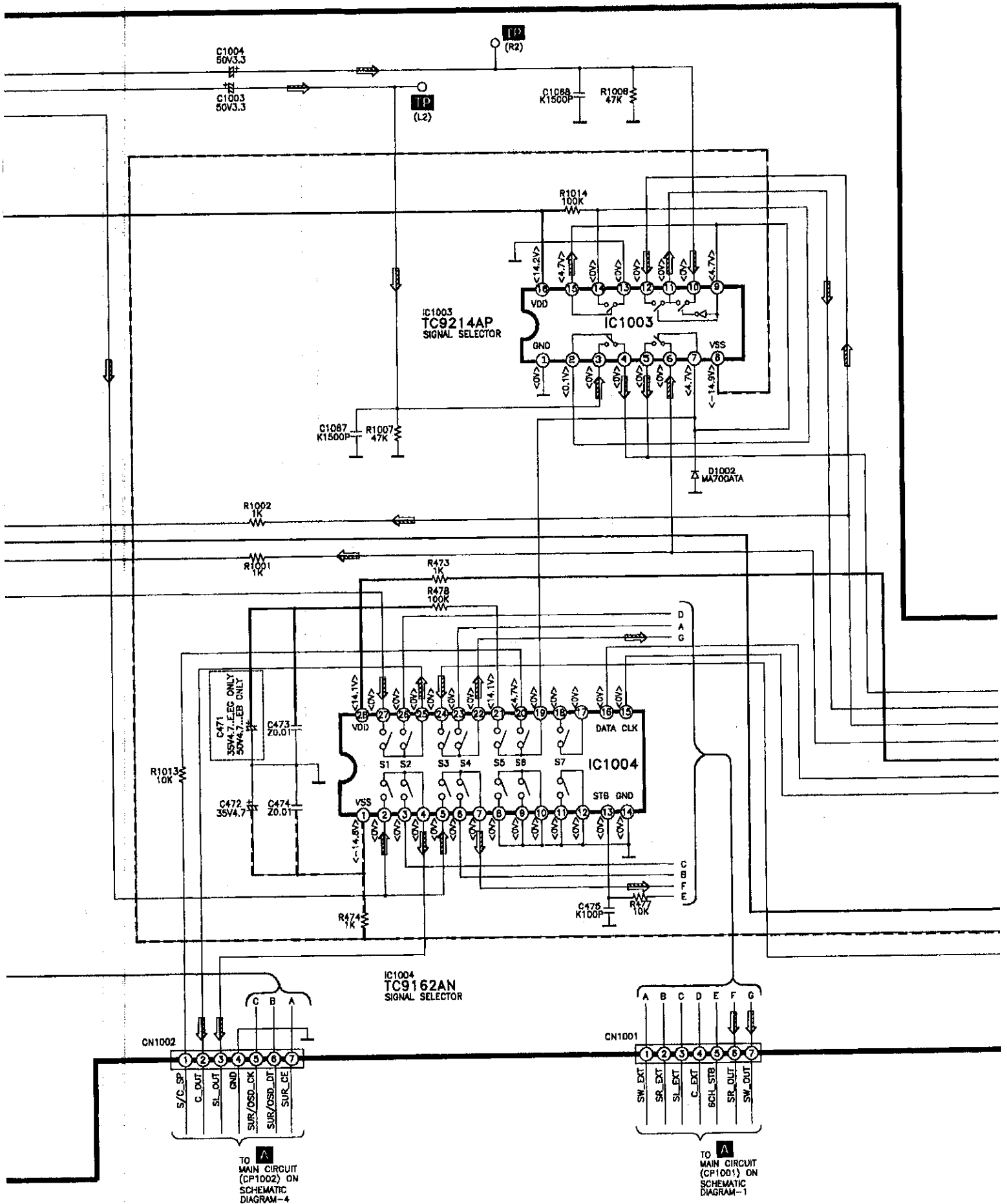

SCHEMATIC DIAGRAM - 12

— : +B line - - - : -B line \Rightarrow : Main signal line \Rightarrow : FM/AM signal line

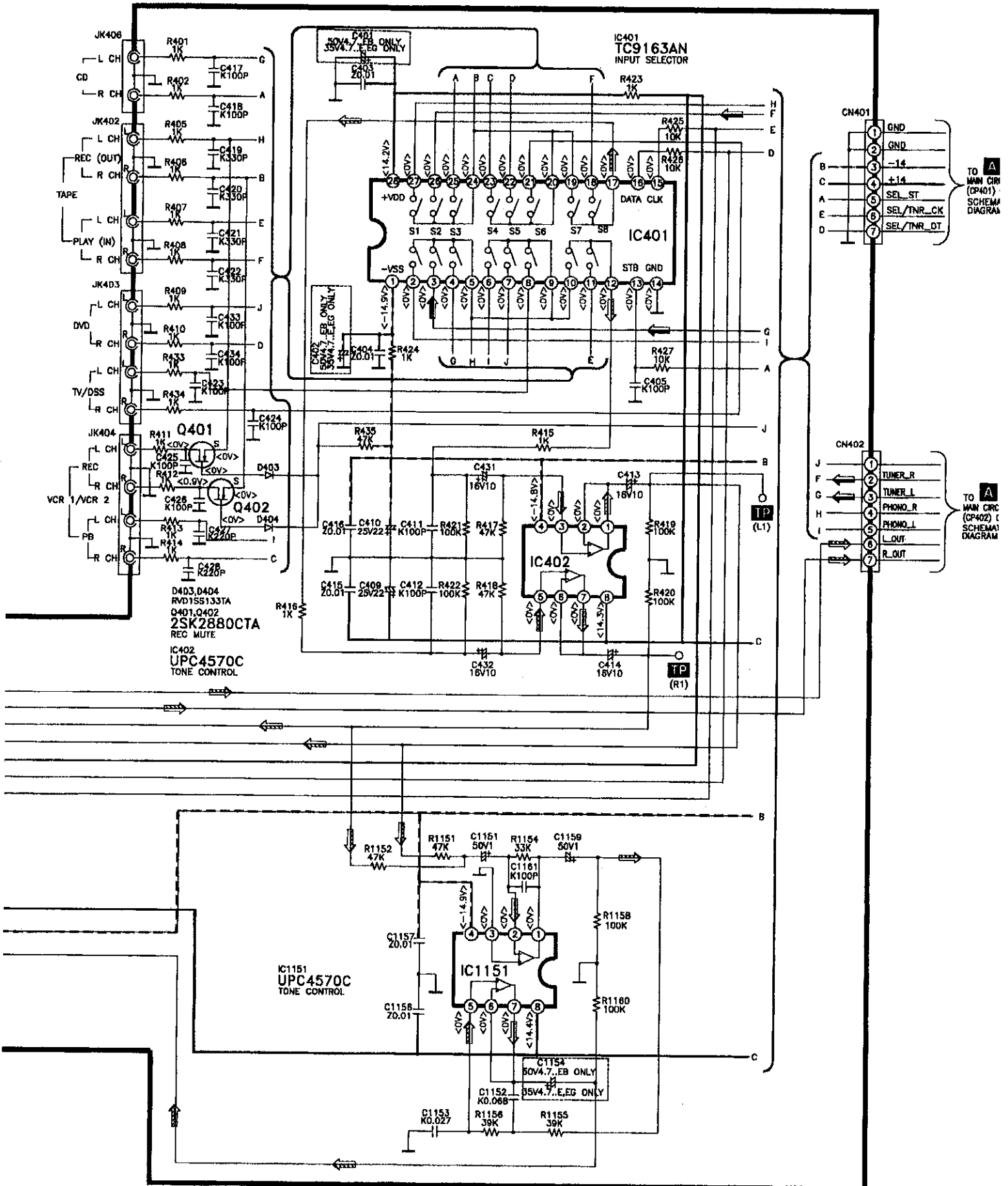

K AC-3 CIRCUIT
(P.C.BOARD ON PAGE 46)

— : +B line - - - : -B line \Rightarrow : Main signal line

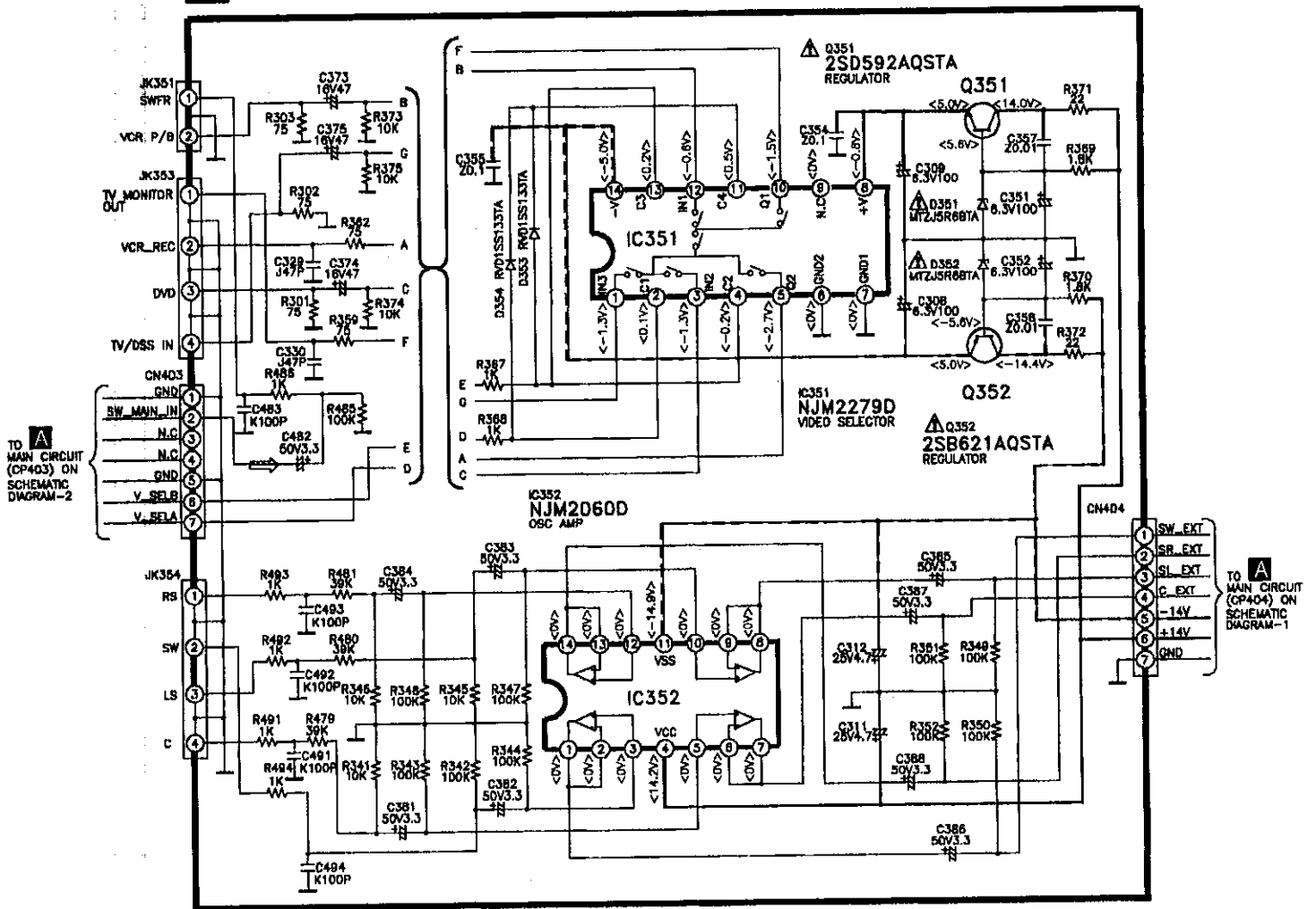

L FRONT SPEAKERS A
(P.C.BOARD ON PAGE 47)

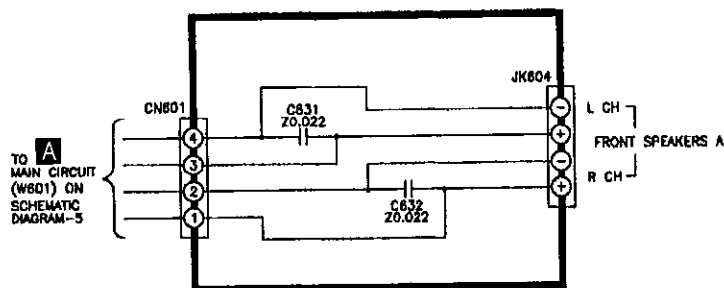

C TUNER CIRCUIT

(P.C.Board on page 47)

- ⇨ : FM Signal Line ⇨⇨ : FM OSC Signal Line
- ⇨ : AM Signal Line ⇨⇨ : AM OSC Signal Line
- : +B Line — : -B Line ⇨ : FM/AM Signal Line

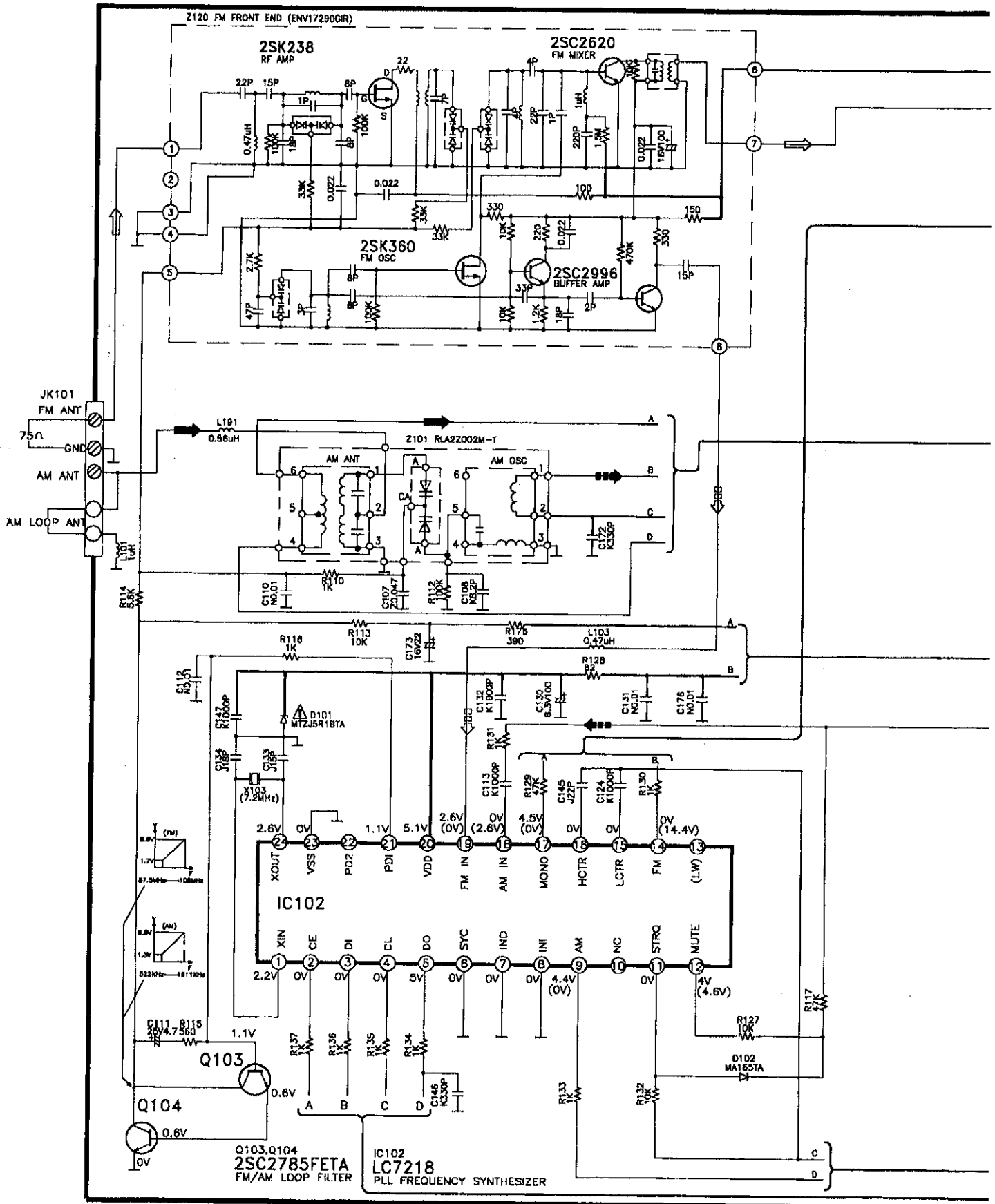

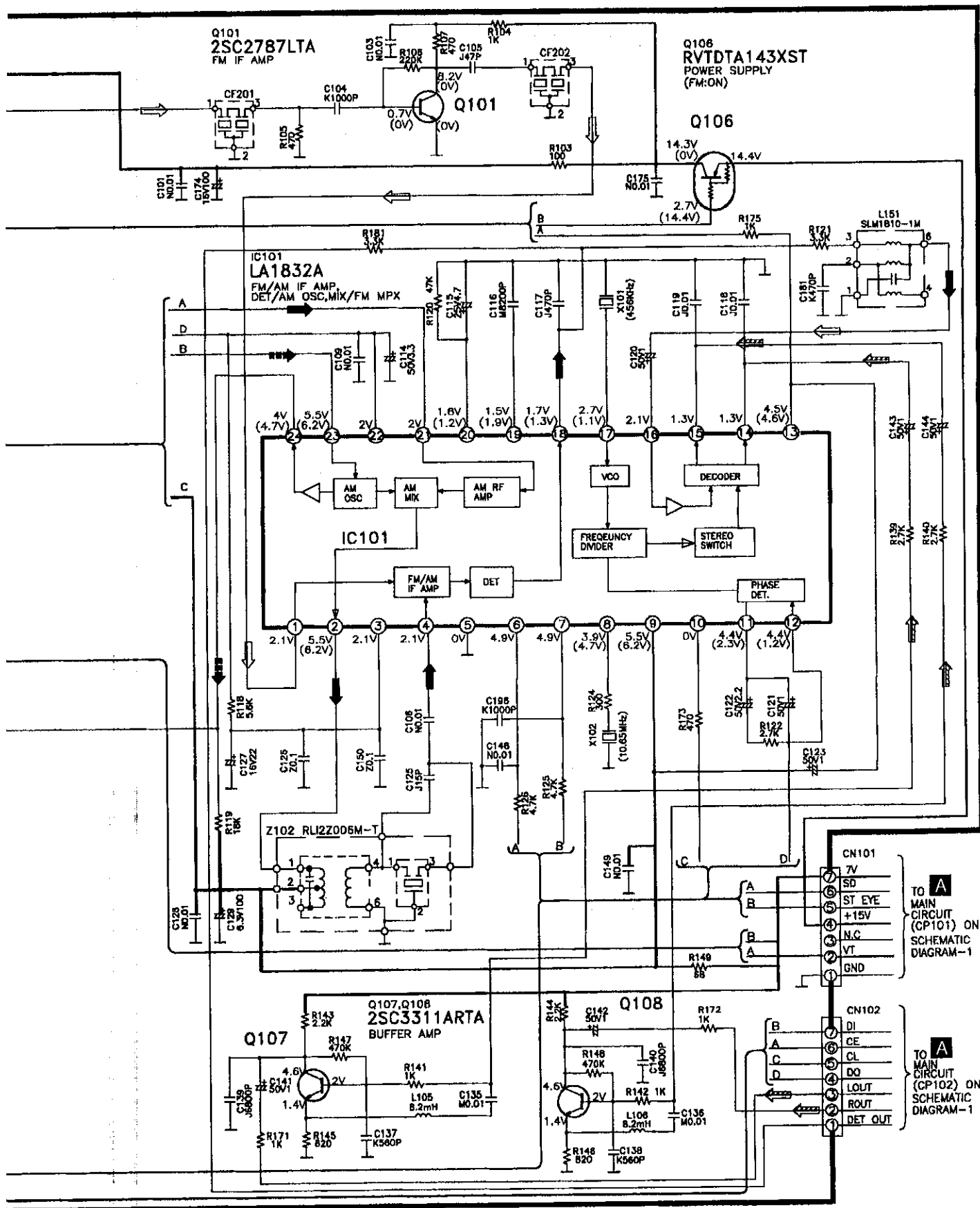
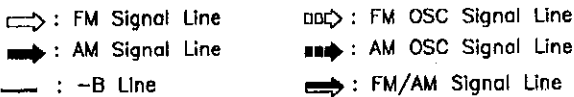

— : +B line

E POWER CIRCUIT
(P.C.BOARD ON PAGE 48)

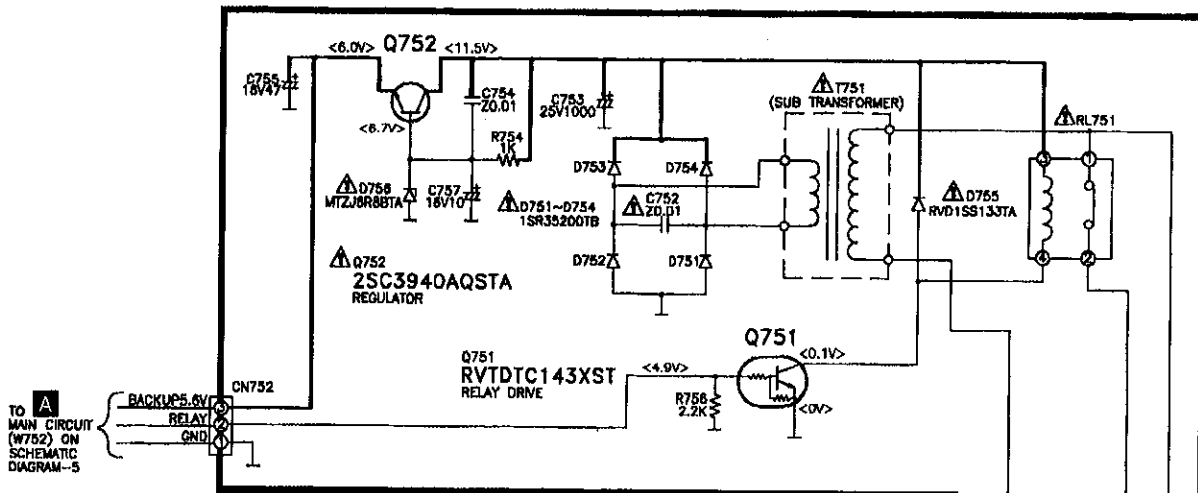

F TRANSFORMER CIRCUIT
(P.C.BOARD ON PAGE 48)

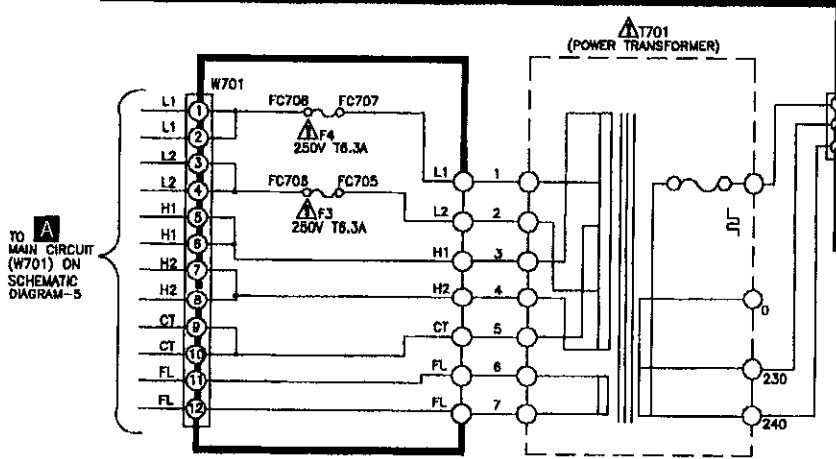

G AC IN/OUT CIRCUIT
(P.C.BOARD ON PAGE 45)

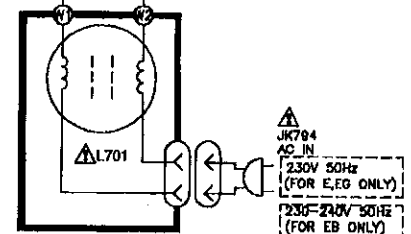

H OPERATION CIRCUIT
(P.C.BOARD ON PAGE 46)

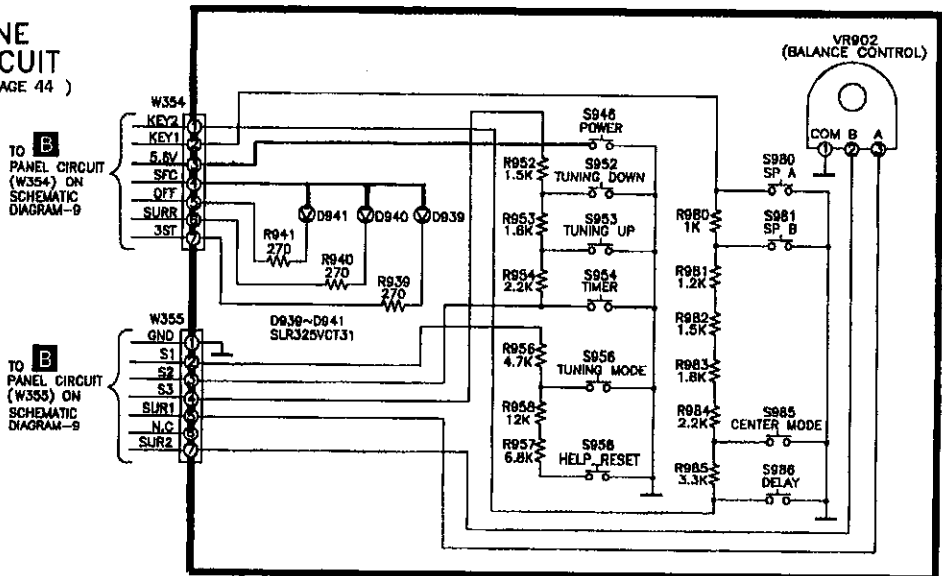

I HEADPHONE JACK CIRCUIT
(P.C.BOARD ON PAGE 44)

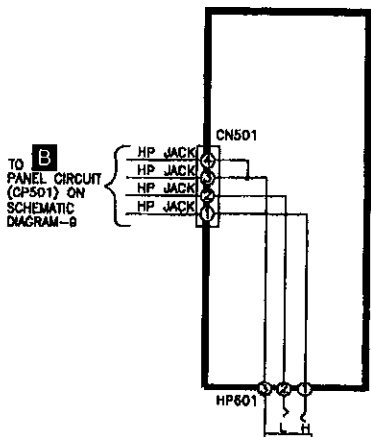

Printed Circuit Board (This printed circuit board diagram may be modified at any time with the development of new technology.)

A B C D E F G H

J PRO LOGIC P.C.B. (REP2629E-P) ... E/EG (REP2629F-P) ... EB

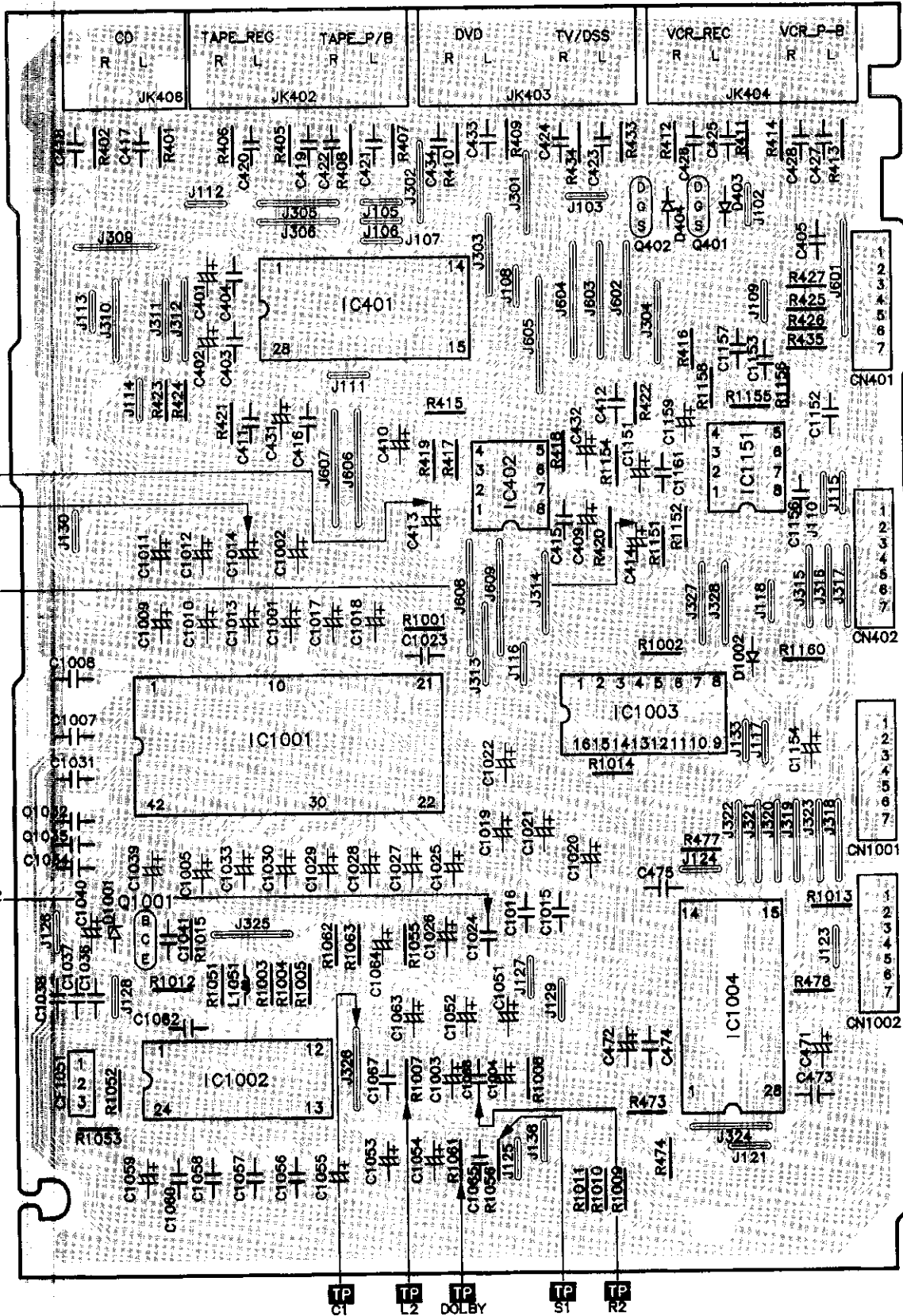

Semiconductors Locations Table

Ref. No	Loc. No
CF1051	A8
CN1001	G7
CN1002	G8
CN1003	E8
CN401	G3
CN402	G5
D1001	B7
D1002	F5
D403	F3
D404	E3
IC1001	C6
IC1002	C8
IC1003	E6
IC1004	F8
IC1151	F4
IC401	C3
IC402	D4
JK402	C2
JK403	D2
JK404	F2
JK406	B2
L1051	C8
Q1001	B7
Q401	F3
Q402	E3

10

A B C D E F G I

A MAIN P.C.B. (REP2627B-M)

1
2
3
4
5
6
7
8
9
10

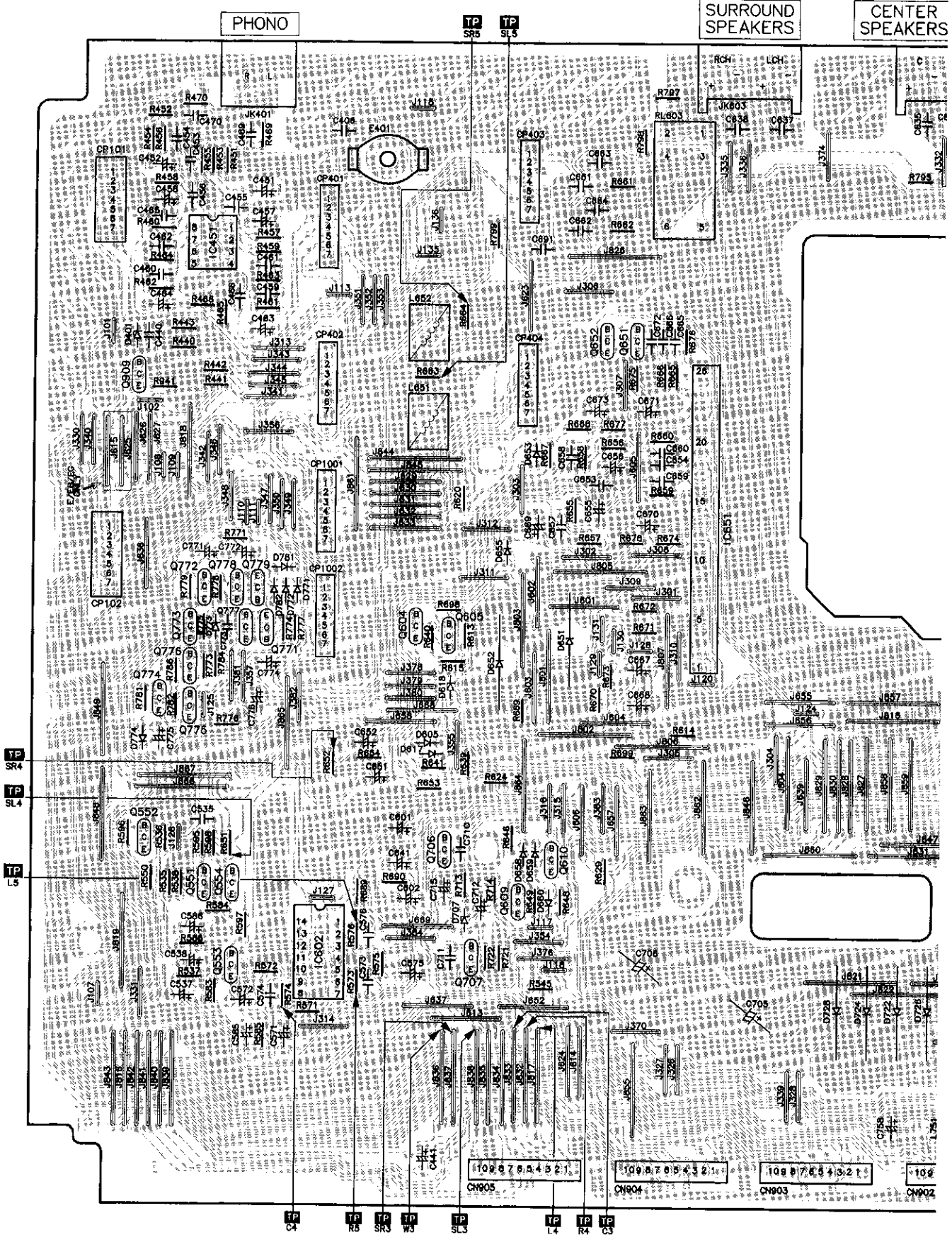

G H I J K L M

UNDERS CENTER SPEAKERS FRONT SPEAKERS B

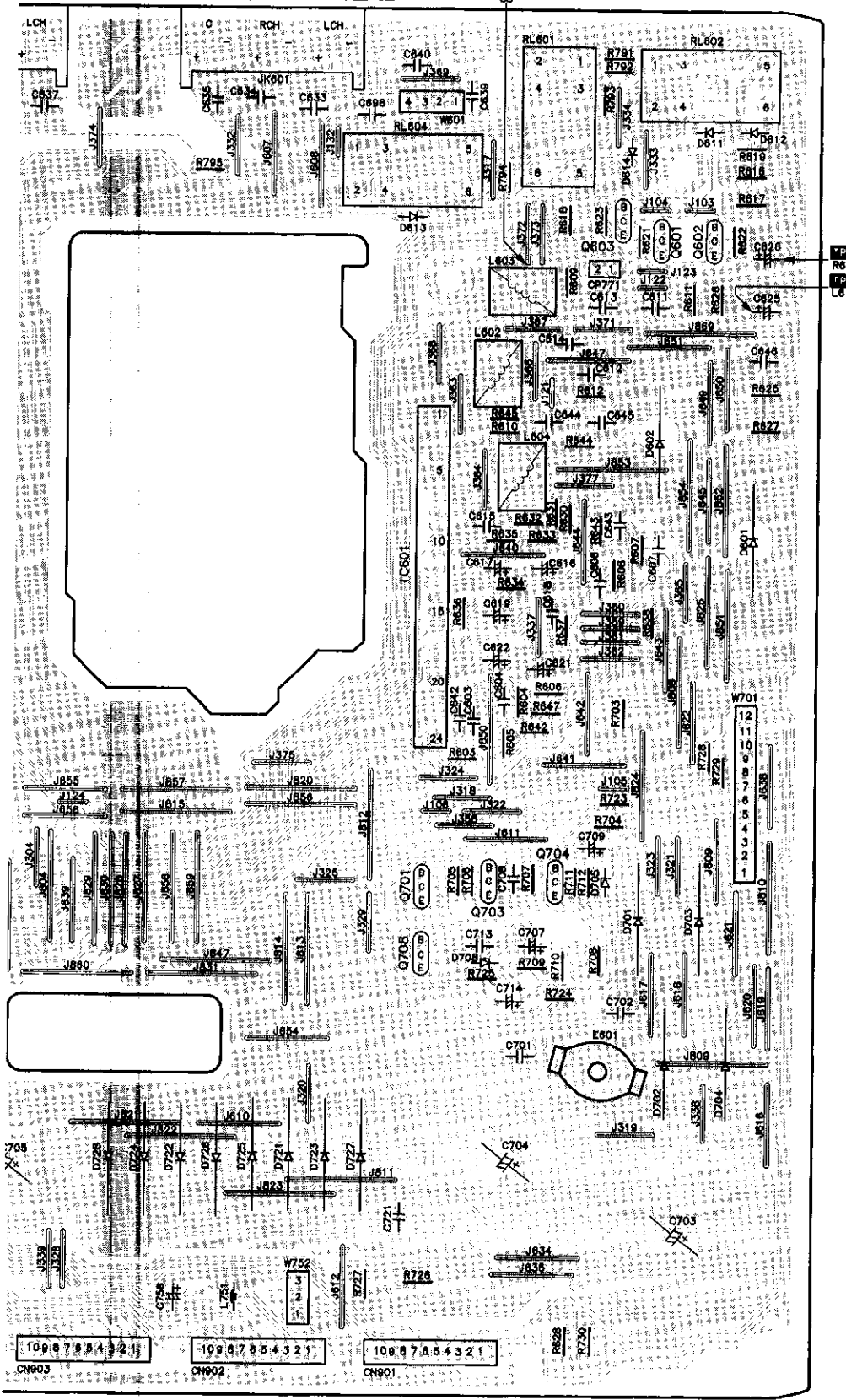

Semiconductors Locations Table

Ref. No	Loc. No	Ref. No	Loc. No
CN901	I10	E601	J8
CN902	G10	IC451	B3
CN903	G10	IC601	I5
CN904	F10	IC651	F5
CN905	E10	JK401	C2
CP1001	C4	JK601	H2
CP1002	C5	JK603	F2
CP101	A2	L602	I3
CP102	A5	L603	I3
CP401	C2	L604	J4
CP402	C3	L651	D4
CP403	E2	L652	D3
CP404	E3	L751	H9
D401	B3	Q551	B7
D601	K4	Q552	B7
D602	J4	Q553	B8
D605	D6	Q554	B7
D611	K2	Q601	J3
D612	K2	Q602	K3
D613	I3	Q603	J3
D614	J2	Q604	D6
D617	D6	Q605	D8
D618	D6	Q609	E8
D651	E6	Q610	E7
D652	D6	Q651	E3
D658	E7	Q652	E3
D659	E7	Q653	E4
D680	E8	Q701	I7
D701	J7	Q703	I7
D702	J8	Q704	I7
D703	K7	Q705	I7
D704	K8	Q706	D7
D705	J7	Q707	D8
D706	I7	Q708	I7
D707	D8	Q771	C6
D721	H8	Q772	B5
D722	G8	Q773	B6
D723	H8	Q774	B6
D724	G8	Q775	B6
D725	H8	Q776	B6
D726	G8	Q777	B6
D727	H8	Q778	B5
D728	G8	Q779	C5
D771	C5	Q909	B4
D772	C5	RL601	J2
D773	B6	RL602	K2
D774	B6	RL603	F2
D781	C5	RL604	I2
D782	C5	W701	K6
E401	D2	W752	H9

A B C D E F G H

B PANEL P.C.B. (REP2628H-S)

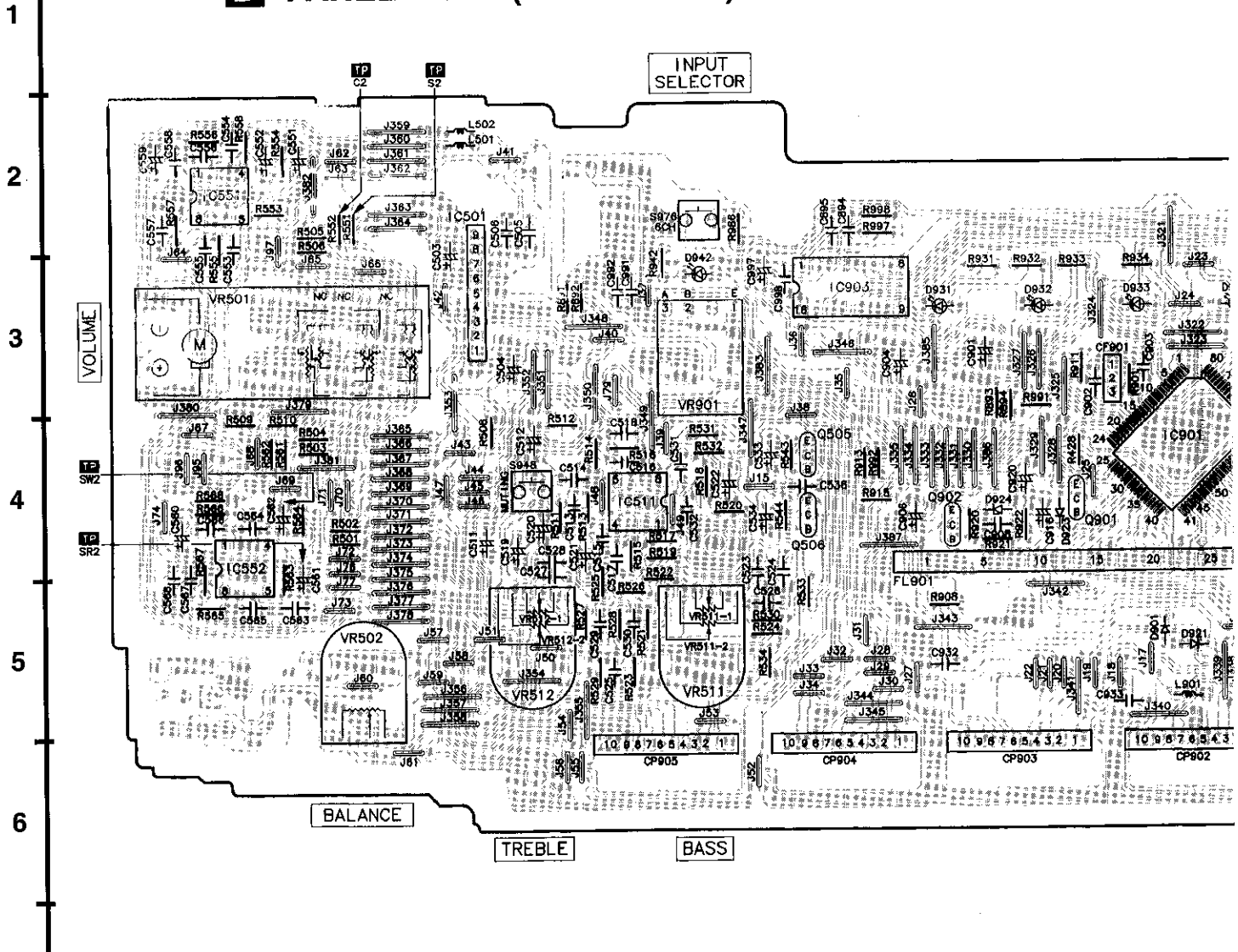

I HEADPHONE JACK P.C.B. (REP2628H-S)

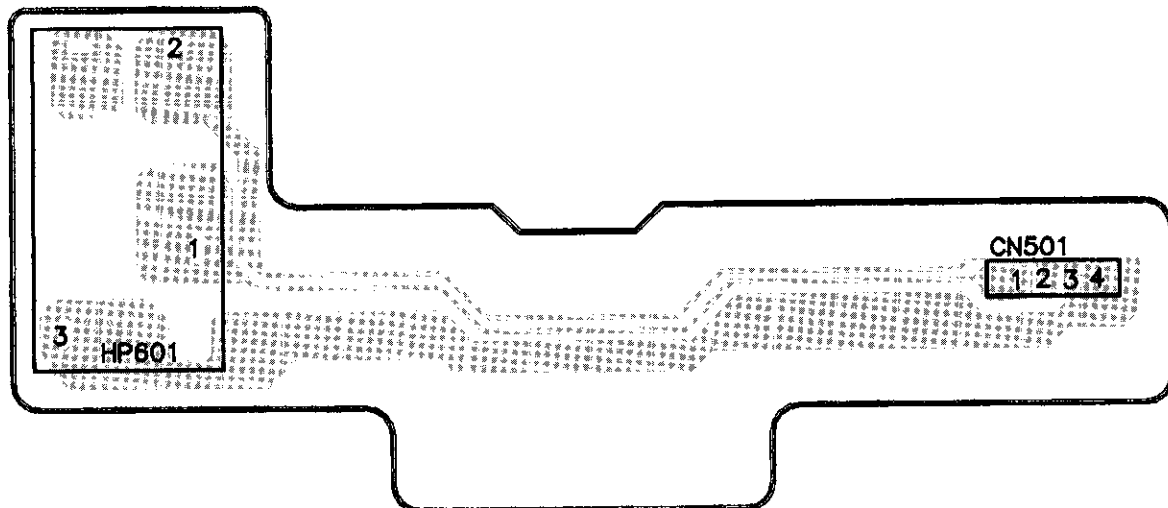

G H I J K L M

Semiconductors Locations Table

Ref. No	Loc. No
CF901	G3
CP501	L6
CP901	I6
CP902	H6
CP904	E8
CP905	D6
D901	G5
D903	K5
D905	H4
D909	I4
D921	H5
D923	G4
D924	F4
D925	K4
D928	J5
D929	J5
D931	F3
D932	G3
D933	G3
D934	H3
D935	I3
D936	I3
D937	J3
D942	E3
IC501	C2
IC511	D4
IC522	B4
IC901	H4
IC902	J4
IC903	F3
L501	C2
L502	C2
L901	H5
L902	K4
L903	K4
Q1681	K5
Q1682	J5
Q505	E4
Q506	E4
Q901	G4
Q902	F4
Q937	K5
Q938	I4
S948	D4
S950	L5
S951	L5
S955	K5
S970	K5
S971	L5
S974	L5
S976	E2
VR501	B3
VR502	B5
VR511	E5
VR511-2	E5
VR512	D5
VR901	E3
VR903	K3
W354	L3
W355	L4

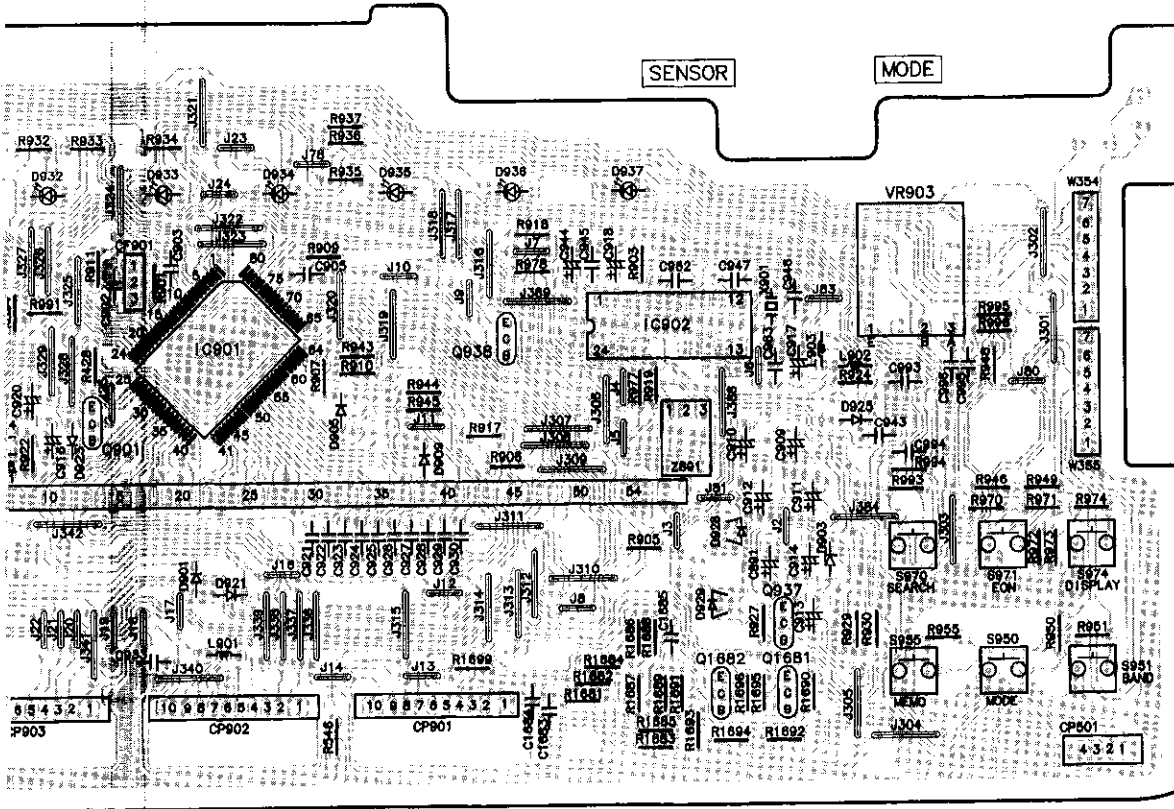

G AC IN/OUT P.C.B. (REP2629E-P) ... E/EG (REP2629F-P) ... EB

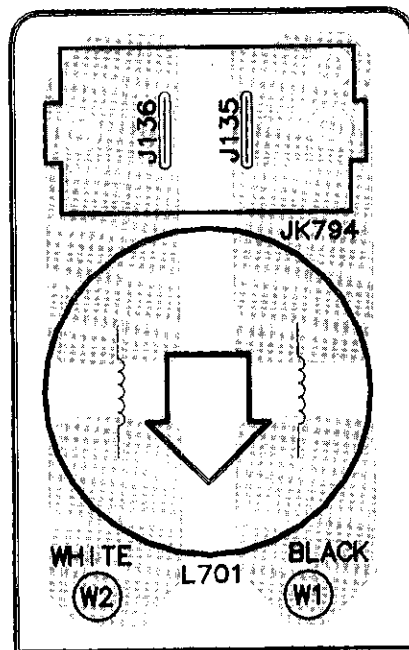

AC IN ~
 230-240V
 50HZ...EB
 230V 50HZ
E/EG

K AC-3 P.C.B. (REP2629E-P) ... E/EG (REP2629F-P) ... EB

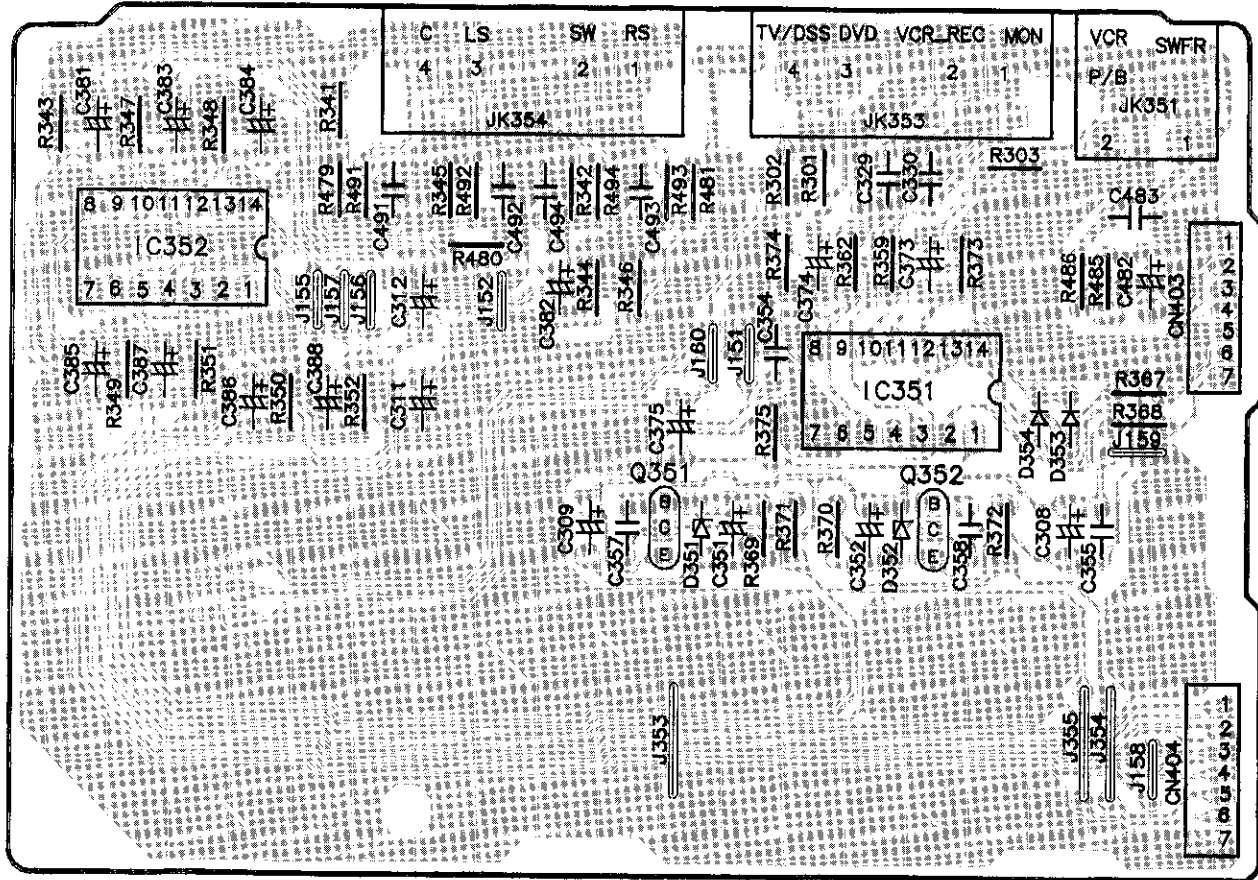

H OPERATION P.C.B. (REP2628H-S)

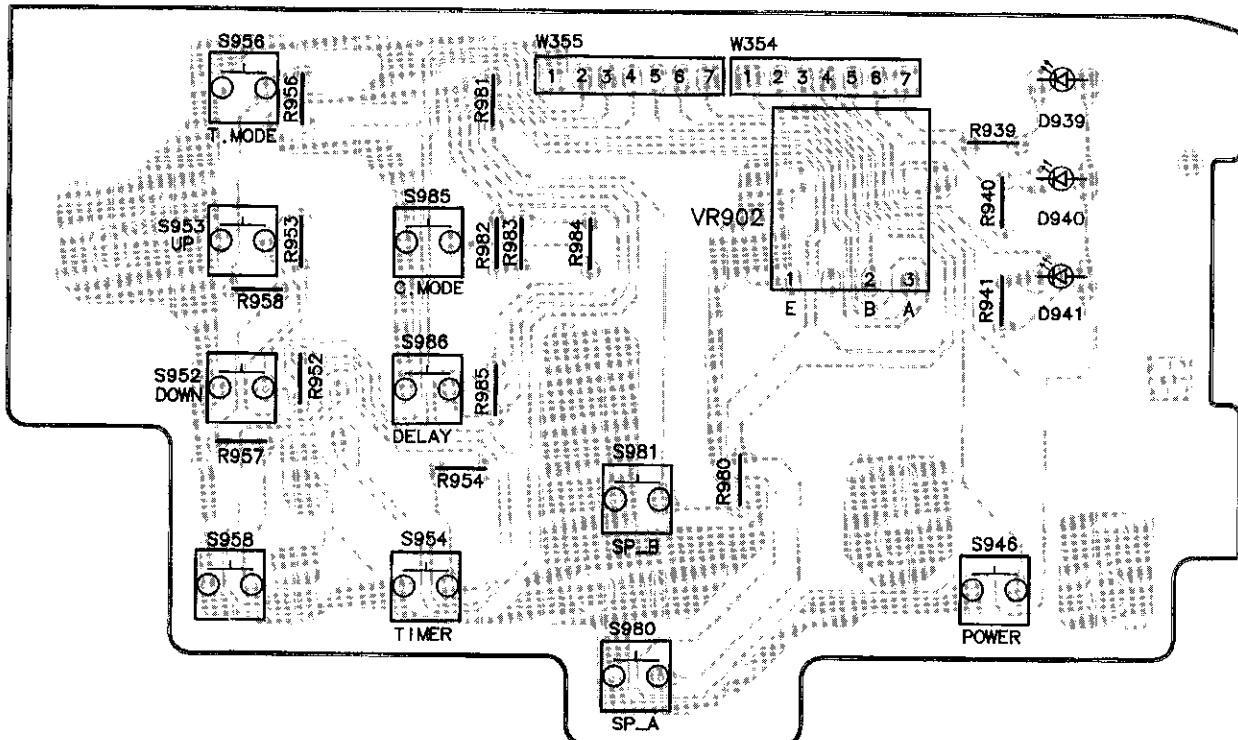

C TUNER P.C.B. (REP2254C-T)

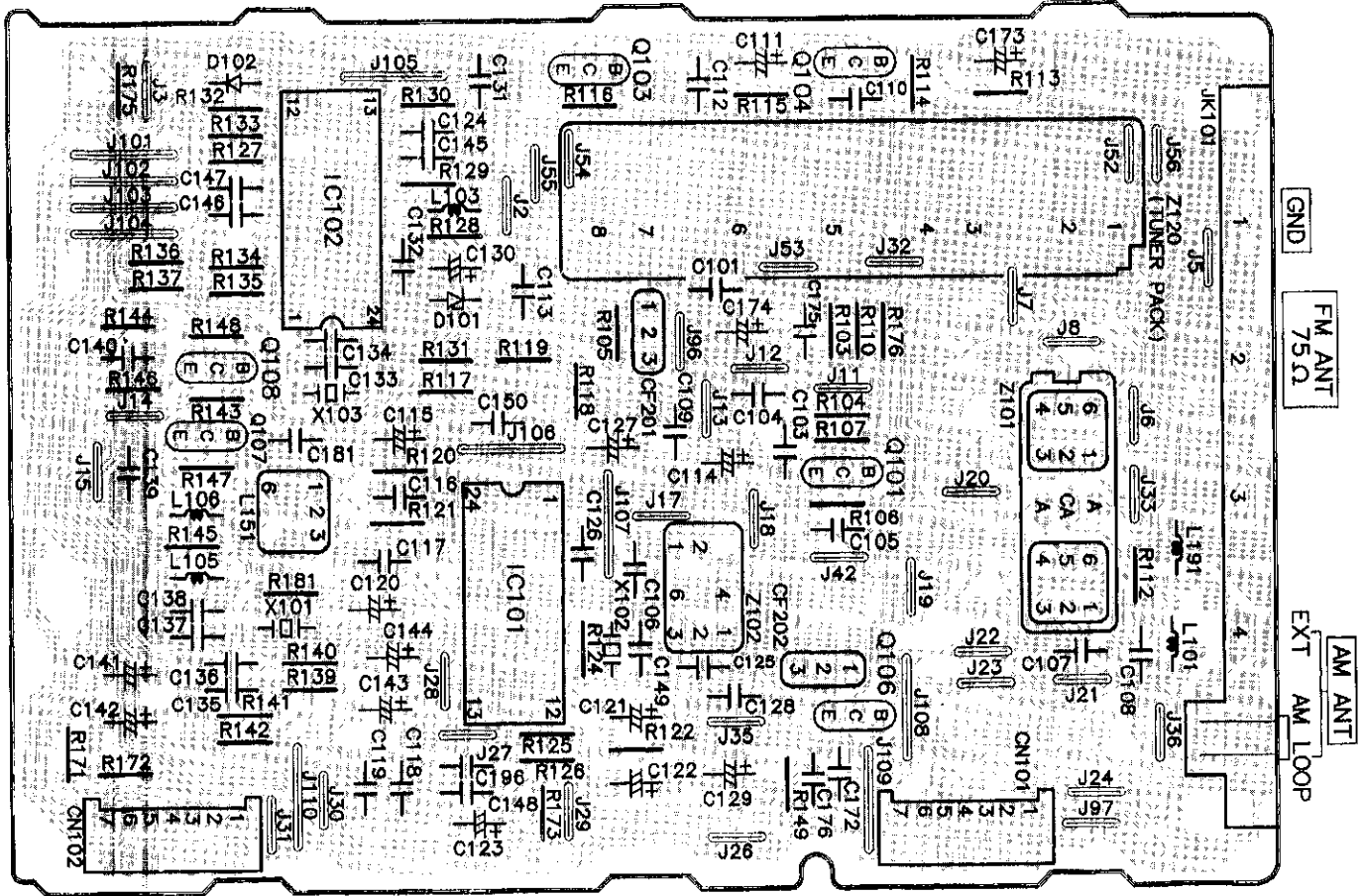

L SPEAKER P.C.B. (REP2629E-P) ... E/EG (REP2629F-P) ... EB

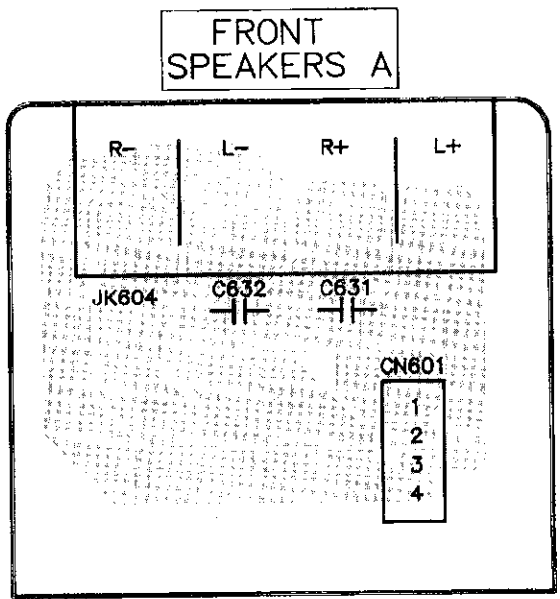

F TRANSFORMER P.C.B. (REP2627B-M)

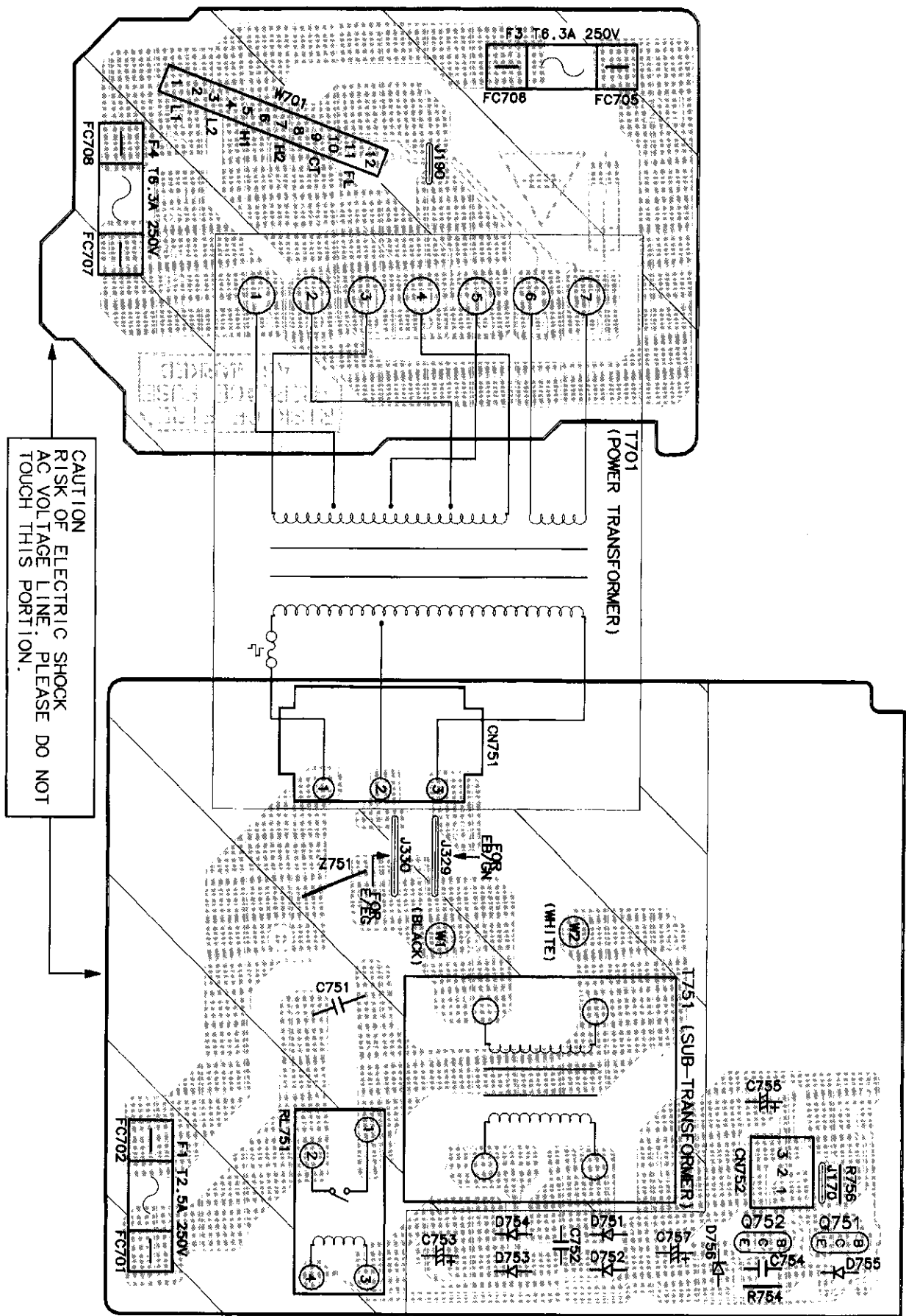

E POWER P.C.B. (REP2629E-P) ... E/EG (REP2629F-P) ... EB

Cabinet Parts Location

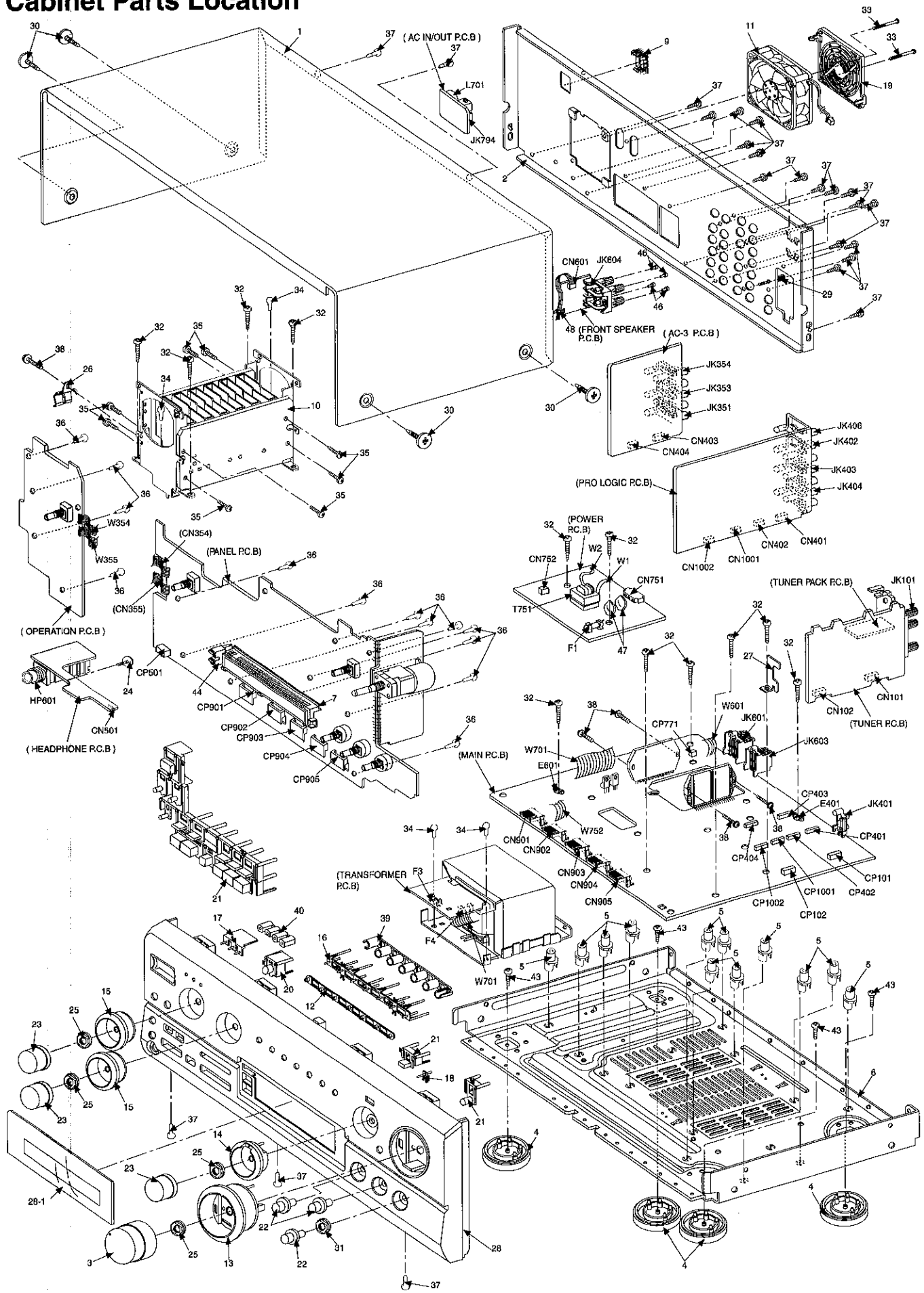

■ Replacement Parts List

Notes: * Important safety notice :

 Components identified by \triangle mark have special characteristics important for safety.

Furthermore, special parts which have purposes of fire-retardant (resistors), high-quality sound (capacitors), low-noise (resistors), etc. are used. When replacing any of components, be sure to use only manufacturer's specified parts shown in the parts list.

* The parenthesized in the Remarks columns specify the areas. (Refer to the cover page for area.)

Parts without these indication can be used for all areas.

* [M] in Remarks column indicates parts that are supplied by MESA.

Ref No.	Part No.	Part Name & Description	Remarks	Ref No.	Part No.	Part Name & Description	Remarks	Ref No.	Part No.	Part Name & Description	Remarks
		CABINET AND CHASSIS		37	XTBS3+8JFZ1	SCREW	[M]	Q104	2SC2785FETA	TRANSISTOR	[M]
				38	XTW3+15T	SCREW	[M]	Q106	RVTDTA143XST	TRANSISTOR	[M]
1	RKM0375-K	TOP CABINET	[M]	39	RMV0158	SEL LED COVER	[M]	Q107	2SC3311ARTA	TRANSISTOR	[M]
2	RGR0285F-D	REAR PANEL	[M]EG E	40	RMV0159	P-L LED COVER	[M]	Q108	2SC3311ARTA	TRANSISTOR	[M]
2	RGR0285F-E	REAR PANEL	[M]EB	43	XTB3+6G	SCREW (FOOT)	[M]	Q351	2SD592AQSTA	TRANSISTOR	[M] \triangle
3	RGW0278-K	VOLUME KNOB	[M]	44	RMN0502	LED HOLDER	[M]	Q352	2SB621AQSTA	TRANSISTOR	[M] \triangle
4	RKA0079-A	LEG UNIT	[M]	46	RMR1185-K	SPEAKER COVER	[M]	Q401	2SK2880CTA	TRANSISTOR	[M]
5	RKQ0089-J	PCB HOLDER	[M]	47	RMZ0339	ZNR COVER	[M]	Q402	2SK2880CTA	TRANSISTOR	[M]
6	RMK0350-3	BOTTOM CHASSIS	[M]	48	SHR301	WIRE CRAMPER	[M]	Q505	2SD1915FTA	TRANSISTOR	[M]
7	RMN0372A	FL HOLDER	[M]			INTEGRATED CIRCUITS		Q506	2SD1915FTA	TRANSISTOR	[M]
9	SJS9231A	A/C INLET COVER	[M]					Q551	2SD1915FTA	TRANSISTOR	[M]
10	RXX0194	HEAT SINK UNIT	[M]					Q552	2SD1915FTA	TRANSISTOR	[M]
11	REM0080	FAN UNIT	[M]	IC101	LA1832A	IC, IF/MPX	[M]	Q553	2SD1915FTA	TRANSISTOR	[M]
12	RGK0992-N	LIGHT GUIDE RING	[M]	IC102	LC7218	IC, PLL	[M]	Q554	2SD1915FTA	TRANSISTOR	[M]
13	RGK0993-N	VOLUME RING	[M]	IC351	NJM2279D	IC, VIDEO SELECTOR	[M]	Q801	RVTDTA143XST	TRANSISTOR	[M]
14	RGK0994-N	SELECTOR RING	[M]	IC352	NJM2080D	IC, OP AMP	[M]	Q602	RVTDTA143XST	TRANSISTOR	[M]
15	RGK0995-N	PRO LOGIC RING	[M]	IC401	TC9163AN	IC, SELECTOR	[M]	Q603	RVTDTA143XST	TRANSISTOR	[M]
16	RGL0401-Q	LIGHT GUIDE	[M]	IC402	UPC4570C	IC, TONE CONTROL	[M]	Q604	RVTDTA114EST	TRANSISTOR	[M]
17	RGL0402-Q	P/L LIGHT GUIDE	[M]	IC451	AN6558F	IC, OP AMP	[M]	Q605	RVTDTA114EST	TRANSISTOR	[M] \triangle
18	RGL0403-Q	8CH LIGHT GUIDE	[M]	IC501	BA6218	IC, MOTOR DRIVER	[M]	Q609	RVTDTA114EST	TRANSISTOR	[M]
19	RGQ0231-K	FAN COVER	[M]	IC511	UPC4570C	IC, TONE CONTROL	[M]	Q610	RVTDTA114TST	TRANSISTOR	[M]
20	RGU1616-K	HELP BUTTON	[M]	IC551	UPC4570C	IC, TONE CONTROL	[M]	Q651	RVTDTA143XST	TRANSISTOR	[M]
21	RGU1617B-K	MODE BUTTON	[M]	IC552	UPC4570C	IC, TONE CONTROL	[M]	Q652	RVTDTA143XST	TRANSISTOR	[M]
22	RGW0279-K	TONE KNOB	[M]	IC601	RSN310R36-P	IC, HIC	[M]	Q701	2SD2374PQAU	TRANSISTOR	[M] \triangle
23	RGW0280-K	SELECTOR KNOB	[M]	IC602	NJM2060D	IC, OP AMP	[M]	Q703	2SC1740SSTA	TRANSISTOR	[M] \triangle
24	RHD26016	SCREW	[M]	IC651	RSN3305-P	IC, HIC	[M]	Q704	2SC1740SSTA	TRANSISTOR	[M] \triangle
25	RHN90001	M9 NUT	[M]	IC901	M36B57M6120F	IC, MICRO COMPUTER	[M]	Q706	2SC3940AQSTA	TRANSISTOR	[M]
26	RMC0158-S	TRANSISTOR HOLDER	[M]	IC902	LC72720N	IC, RDS	[M]	Q707	2SA1534AQRTA	TRANSISTOR	[M] \triangle
27	RMQ0709	TUNER PCB BRACKET	[M]	IC903	BU2090A	IC, EXPENDER	[M]	Q708	2SB1548PQAU	TRANSISTOR	[M] \triangle
28	RFKGAAX730EK	FRONT PANEL ASS'Y	[M]	IC1001	LA2786L	IC, DPL	[M]	Q751	RVTDTA143XST	TRANSISTOR	[M]
28-1	RKW0533F-Q	F/L WINDOW	[M]	IC1002	LV1016L	IC, SURR DECODER	[M]	Q752	2SC3940AQSTA	TRANSISTOR	[M]
29	SNE2123	EARTH TERMINAL	[M]	IC1003	TC9214AP	IC, SELECTOR	[M]	Q771	2SA933SSTA	TRANSISTOR	[M]
30	SNE2129-1	SCREW (CABINET)	[M]	IC1004	TC9162AN	IC, SELECTOR	[M]	Q772	2SC1740SSTA	TRANSISTOR	[M]
31	SNE4021-1	M8 NUT	[M]	IC1151	UPC4570C	IC, TONE CONTROL	[M]	Q773	2SB621AQSTA	TRANSISTOR	[M]
32	XTB3+20JFZ	SCREW	[M]			TRANSISTORS		Q774	RVTDTA113ZST	TRANSISTOR	[M]
33	XTB3+35JFZ	SCREW (FAN)	[M]					Q775	RVTDTA114EST	TRANSISTOR	[M]
34	XTB3+8FFZ	SCREW	[M]					Q776	2SC1740SSTA	TRANSISTOR	[M]
35	XTB3+8JFZ	SCREW	[M]	Q101	2SC2787LTA	TRANSISTOR	[M]	Q777	2SA933SSTA	TRANSISTOR	[M]
36	XTBS26+10J	SCREW	[M]	Q103	2SC2785FETA	TRANSISTOR	[M]	Q778	2SA933SSTA	TRANSISTOR	[M]

Ref No.	Part No.	Part Name & Description	Remarks	Ref No.	Part No.	Part Name & Description	Remarks	Ref No.	Part No.	Part Name & Description	Remarks
Q779	2SA933SSTA	TRANSISTOR	[M]	D725	1N5402BM21	DIODE	[M] △	VR903	EVQVBHFK112B	VR, BALANCE CONTROL	[M]
Q901	RVTDTTC114YST	TRANSISTOR	[M]	D726	1N5402BM21	DIODE	[M] △				
Q902	2SA933SSTA	TRANSISTOR	[M] △	D727	1N5402BM21	DIODE	[M] △			SWITCHES	
Q909	2SC1740SSTA	TRANSISTOR	[M]	D728	1N5402BM21	DIODE	[M] △				
Q937	RVTDTA114YST	TRANSISTOR	[M]	D751	1SR35200TB	DIODE	[M] △	S946	EVQ21405R	SW, POWER	[M]
Q938	RVTDTTC114YST	TRANSISTOR	[M]	D752	1SR35200TB	DIODE	[M] △	S948	EVQ21405R	SW, MUTING	[M]
Q1001	2SC3940AQSTA	TRANSISTOR	[M] △	D753	1SR35200TB	DIODE	[M] △	S950	EVQ21405R	SW, FM MODE	[M]
Q1681	2SD1915FTA	TRANSISTOR	[M]	D754	1SR35200TB	DIODE	[M] △	S951	EVQ21405R	SW, BAND	[M]
Q1682	2SD1915FTA	TRANSISTOR	[M]	D755	RVD1SS133TA	DIODE	[M] △	S952	EVQ21405R	SW, TUNING DOWN	[M]
		DIODES		D756	MTZJ6R8BTA	DIODE	[M] △	S953	EVQ21405R	SW, TUNING UP	[M]
				D771	MA700ATA	DIODE	[M]	S954	EVQ21405R	SW, TIMER	[M]
				D772	MA700ATA	DIODE	[M]	S955	EVQ21405R	SW, MEMORY	[M]
D101	MTZJ6R1BTA	DIODE	[M] △	D773	MTZJ9R1CTA	DIODE	[M]	S956	EVQ21405R	SW, TUNING MODE	[M]
D102	MA165TA	DIODE	[M]	D774	RVD1SS133TA	DIODE	[M]	S958	EVQ21405R	SW, HELP	[M]
D351	MTZJ5R6BTA	DIODE	[M] △	D781	MA700ATA	DIODE	[M]	S970	EVQ21405R	SW, SEARCH	[M]
D352	MTZJ5R6BTA	DIODE	[M] △	D782	MA700ATA	DIODE	[M]	S971	EVQ21405R	SW, EON	[M]
D353	RVD1SS133TA	DIODE	[M]	D901	1SS2917A	DIODE	[M]	S974	EVQ21405R	SW, DISPLAY MODE	[M]
D354	RVD1SS133TA	DIODE	[M]	D903	MTZJ4R7BTA	DIODE	[M]	S976	EVQ21405R	SW, DVD-6CH	[M]
D401	MTZJ7R5CTA	DIODE	[M]	D905	MA167ATA	DIODE	[M]	S980	EVQ21405R	SW, SPEAKER A	[M]
D403	RVD1SS133TA	DIODE	[M]	D909	MA167ATA	DIODE	[M]	S981	EVQ21405R	SW, SPEAKER B	[M]
D404	RVD1SS133TA	DIODE	[M]	D921	RVD1SS133TA	DIODE	[M]	S985	EVQ21405R	SW, CENTER A	[M]
D601	RK306LFU1	DIODE	[M]	D923	RVD1SS133TA	DIODE	[M]	S986	EVQ21405R	SW, DELAY	[M]
D602	RK306LFU1	DIODE	[M]	D924	MTZJ3R9ATA	DIODE	[M] △			CONNECTORS	
D605	RVD1SS133TA	DIODE	[M]	D925	RVD1SS133TA	DIODE	[M]				
D611	RVD1SS133TA	DIODE	[M]	D928	LN446YPH	DIODE	[M]	CN101	RJU057W007	7P CONNECTOR	[M]
D612	RVD1SS133TA	DIODE	[M]	D929	LN846RPH	DIODE	[M]	CN102	RJU057W007	7P CONNECTOR	[M]
D613	RVD1SS133TA	DIODE	[M]	D931	SLR325VCT31	DIODE	[M]	CN401	RJU100W07	7P CONNECTOR	[M]
D614	RVD1SS133TA	DIODE	[M]	D932	SLR325VCT31	DIODE	[M]	CN402	RJU100W07	7P CONNECTOR	[M]
D617	RVD1SS133TA	DIODE	[M]	D933	SLR325VCT31	DIODE	[M]	CN403	RJU100W07	7P CONNECTOR	[M]
D618	MTZJ9R1CTA	DIODE	[M] △	D934	SLR325VCT31	DIODE	[M]	CN404	RJU100W07	7P CONNECTOR	[M]
D651	RK306LFU1	DIODE	[M]	D935	SLR325VCT31	DIODE	[M]	CN501	RJU100W04	4P CONNECTOR	[M]
D652	RK306LFU1	DIODE	[M]	D936	SLR325VCT31	DIODE	[M]	CN601	RJS4T6ZA	4P CONNECTOR	[M]
D653	RVD1SS133TA	DIODE	[M]	D937	SLR325VCT31	DIODE	[M]	CN751	SJS305-1	3P CONNECTOR	[M]
D655	RVD1SS133TA	DIODE	[M]	D939	SLR325VCT31	DIODE	[M]	CN752	RJS1A6603T1	3P TAPING CONNECTOR	[M]
D658	RVD1SS133TA	DIODE	[M]	D940	SLR325VCT31	DIODE	[M]	CN901	RJU003K010M1	10P B/B CONNECTOR	[M]
D659	RVD1SS133TA	DIODE	[M]	D941	SLR325VCT31	DIODE	[M]	CN902	RJU003K010M1	10P B/B CONNECTOR	[M]
D660	RVD1SS133TA	DIODE	[M]	D942	SLR325MCT31	DIODE	[M]	CN903	RJU003K010M1	10P B/B CONNECTOR	[M]
D701	1N5402BM21	DIODE	[M] △	D1001	MTZJ10CTA	DIODE	[M] △	CN904	RJU003K010M1	10P B/B CONNECTOR	[M]
D702	1N5402BM21	DIODE	[M] △	D1002	MA700ATA	DIODE	[M]	CN905	RJU003K010M1	10P B/B CONNECTOR	[M]
D703	1N5402BM21	DIODE	[M] △			VARIABLE RESISTORS		CN1001	RJU100W07	7P CONNECTOR	[M]
D704	1N5402BM21	DIODE	[M] △					CN1002	RJU100W07	7P CONNECTOR	[M]
D705	MTZJ6R2BTA	DIODE	[M] △	VR501	EUWM6A026B15	VR, MOTOR VOLUME	[M]	CP101	RJT057W007-1	7P CONNECTOR	[M]
D707	MTZJ27DTA	DIODE	[M] △	VR502	EWCOYAF20G15	VR, BALANCE CONTROL	[M]	CP102	RJT057W007-1	7P CONNECTOR	[M]
D708	MTZJ15CTA	DIODE	[M] △	VR511	EWCI1XA020C15	VR, TONE CONTROL	[M]	CP401	RJT100W07	7P CONNECTOR	[M]
D721	1N5402BM21	DIODE	[M] △	VR512	EWCI1XA020C15	VR, TONE CONTROL	[M]	CP402	RJT100W07	7P CONNECTOR	[M]
D722	1N5402BM21	DIODE	[M] △	VR901	EVQVBHFK112B	VR, BALANCE CONTROL	[M]	CP403	RJT100W07	7P CONNECTOR	[M]
D723	1N5402BM21	DIODE	[M] △	VR902	EVQVBHFK112B	VR, BALANCE CONTROL	[M]	CP404	RJT100W07	7P CONNECTOR	[M]
D724	1N5402BM21	DIODE	[M] △								

Ref No.	Part No.	Part Name & Description	Remarks	Ref No.	Part No.	Part Name & Description	Remarks	Ref No.	Part No.	Part Name & Description	Remarks
CP501	RJT100W04	4P CONNECTOR	[M]			RELAY		JK604	RJH4410	JK, SPEAKER	[M]
CP771	SJT3213	CONNECTOR (FAN)	[M]					JK794	SJS9231-1B	JK, SOCKET	[M] △
CP901	RJT003K010M1	10P CONNECTOR	[M]	RL601	RSY0013M-0	RELAY	[M]				
CP902	RJT003K010M1	10P CONNECTOR	[M]	RL602	RSY0013M-0	RELAY	[M]			EARTH TERMINAL	
CP903	RJT003K010M1	10P CONNECTOR	[M]	RL603	RSY0013M-0	RELAY	[M]				
CP904	RJT003K010M1	10P CONNECTOR	[M]	RL604	RSY0013M-0	RELAY	[M]	E401	SNE1004-2	EARTH TERMINAL	[M]
CP905	RJT003K010M1	10P CONNECTOR	[M]	RL751	RSY0019M-0	12V TV-5 RELAY	[M] △	E601	SNE1004-2	EARTH TERMINAL	[M]
CP1001	RJT100W07	7P CONNECTOR	[M]								
CP1002	RJT100W07	7P CONNECTOR	[M]			OSCILLATORS				WIRES	
		COILS & TRANSFORMERS		X101	RSXZ456KM07M	CERAMIC OSCILLATOR	[M]	W1	REE0889	WIRE	[M]
				X102	RLFDGTD01I	FM REZONATOR	[M]	W2	REE0890	WIRE	[M]
L101	ELESN1R0MA	CHOKE COIL	[M]	X103	RSXD7M20C01	CRYSTAL 7.2 MHZ	[M]	W354	RWJ1807200KK	7P WIRE	[M]
L103	ELEXR47MA9	CHOKE COIL	[M]	X901	RSXC4M33S02T	CRYSTAL 4.33 MHZ	[M]	W355	RWJ1807200KK	7P WIRE	[M]
L105	RLQZB822KT-D	TAPING COIL	[M]					W601	RWJ1804180KQ	SPK TERMINAL WIRE	[M]
L106	RLQZB822KT-D	TAPING COIL	[M]			DISPLAY TUBE		W701	RWJ1812220KK	WIRE UNIT	[M]
L151	SLM1B10-1M	A.B. FILTER	[M]					W752	RWJ1803290CQ	WIRE	[M]
L191	ELESNR56MA	CHOKE COIL	[M]	FL901	RSL0254-F	FL	[M]				
L501	RLQZP1R0KT-Y	AXIAL COIL	[M]								
L502	RLQZP1R0KT-Y	AXIAL COIL	[M]			FUSES					
L602	RLQYR73MW-E	CHOKE COIL	[M]	F1	XBA2C25TB0	FUSE	[M] △				
L603	RLQYR73MW-E	CHOKE COIL	[M]	F3	XBA2C63TB0	FUSE	[M] △				
L604	RLQYR73MW-E	CHOKE COIL	[M]	F4	XBA2C63TB0	FUSE	[M] △				
L651	RLQYR73MW-E	CHOKE COIL	[M]								
L652	RLQYR73MW-E	CHOKE COIL	[M]			FUSE HOLDERS					
L701	SLQZ650MH49	AC LINE COIL	[M]								
L751	RLQB101KTA-Y	CHOKE COIL	[M]	FC701	RJR0169T	FUSE HOLDER	[M]				
L901	RLQB101KTA-Y	CHOKE COIL	[M]	FC702	RJR0169T	FUSE HOLDER	[M]				
L902	RLQZP101KT-Y	AXIAL COIL	[M]	FC705	RJR0169T	FUSE HOLDER	[M]				
L903	RLQZP101KT-Y	AXIAL COIL	[M]	FC706	RJR0169T	FUSE HOLDER	[M]				
L1051	RLQB101KTA-Y	CHOKE COIL	[M]	FC707	RJR0169T	FUSE HOLDER	[M]				
T701	RTP1Q5B005-V	POWER TRANSFORMER	[M] △	FC708	RJR0169T	FUSE HOLDER	[M]				
T751	RTP115E006	POWER TRANSFORMER	[M] △								
		COMPONENT COMBINATION				JACKS					
Z101	RLA2Z002M-T	AM ANT. COIL	[M]	HP601	RJH3TA01	HP JACK	[M]				
Z102	RLI2Z006M-T	AM IFT	[M]	JK101	RJH4202-1	JK, ANT TERMINAL	[M]				
Z120	ENV17290G1Y	FM TUNER PACK	[M]	JK351	RJH3210N	JK, 2P RCA PIN	[M]				
Z751	ERZV10V511CS	ZNR	[M] △	JK353	SJF3069-3N	JK, RCA PIN	[M]				
Z891	RCD12042TE	REMOTE SENSOR	[M]	JK354	SJF3069-16N	JK, RCA TERMINAL	[M]				
				JK401	SJF3068-7N	JK, RCA TERMINAL	[M]				
				JK402	SJF3069N	JK, LINE IN	[M]				
		CERAMIC FILTERS		JK403	SJF3069N	JK, LINE IN	[M]				
				JK404	SJF3069N	JK, LINE IN	[M]				
CF201	RLFFETNGD01L	CERAMIC CAPACITOR	[M]	JK406	SJF3068-7N	JK, RCA TERMINAL	[M]				
CF202	RLFFETMGD01L	CERAMIC FILTER	[M]	JK601	RJH5601	JK, SPK TERMINAL	[M]				
CF901	RVCBST4R00MT	CERAMIC OSCILLATOR	[M]	JK603	RJR0054	JK, SPK TERMINAL	[M]				
CF1051	RSXY8M00D01T	CERAMIC OSILLATOR	[M]								

Resistors & Capacitors

- Notes :
- Important safety notice:
Components identified by \triangle mark have special characteristics important for safety. Furthermore, special parts which have purposes of fire-retardant (resistors), high-quality sound (capacitors), low-noise (resistors), etc. are used. When replacing any of components, be sure to use only manufacturer's specified parts shown in the parts list.
 - The parenthesized in the Remarks columns specify the areas. (Refer to the cover page for area.) Parts without these indication can be used for all areas.
 - [M] in Remarks column indicates parts that are supplied by MESA.
 - Capacitor values are in microfarad (μ F) unless specified otherwise, P=Pico-farads (pF) F=Farads (F)
 - Resistors values are in ohms, unless specified otherwise, 1k=1,000(OHM), 1M=1,000k(OHM)

Ref No.	Part No.	Values & Remarks	Ref No.	Part No.	Values & Remarks	Ref No.	Part No.	Values & Remarks	Ref No.	Part No.	Values & Remarks
RESISTORS			R146	ERDS2TJ821T	820 1/4W [M]	R407	ERDS2TJ102T	1K 1/4W [M]	R462	ERDS2TJ184T	180K 1/4W [M]
			R147	ERDS2TJ474T	470K 1/4W [M]	R408	ERDS2TJ102T	1K 1/4W [M]	R463	ERDS2TJ123T	12K 1/4W [M]
R103	ERDS2TJ101T	100 1/4W [M]	R148	ERDS2TJ474T	470K 1/4W [M]	R409	ERDS2TJ102T	1K 1/4W [M]	R464	ERDS2TJ123T	12K 1/4W [M]
R104	ERDS2TJ102T	1K 1/4W [M]	R149	ERDS2TJ680T	68 1/4W [M]	R410	ERDS2TJ102T	1K 1/4W [M]	R465	ERDS2TJ583T	56K 1/4W [M]
R105	ERDS2TJ471T	470 1/4W [M]	R171	ERDS2TJ102T	1K 1/4W [M]	R411	ERDS2TJ102T	1K 1/4W [M]	R466	ERDS2TJ583T	56K 1/4W [M]
R106	ERDS2TJ224T	220K 1/4W [M]	R172	ERDS2TJ102T	1K 1/4W [M]	R412	ERDS2TJ102T	1K 1/4W [M]	R469	ERDS2TJ102T	1K 1/4W [M]
R107	ERDS2TJ471T	470 1/4W [M]	R173	ERDS2TJ471T	470 1/4W [M]	R413	ERDS2TJ102T	1K 1/4W [M]	R470	ERDS2TJ102T	1K 1/4W [M]
R110	ERDS2TJ102T	1K 1/4W [M]	R175	ERDS2TJ102T	1K 1/4W [M]	R414	ERDS2TJ102T	1K 1/4W [M]	R473	ERDS2TJ102T	1K 1/4W [M]
R112	ERDS2TJ104T	100K 1/4W [M]	R176	ERDS2TJ391T	390 1/4W [M]	R415	ERDS2TJ102T	1K 1/4W [M]	R474	ERDS2TJ102T	1K 1/4W [M]
R113	ERDS2TJ103T	10K 1/4W [M]	R181	ERDS2TJ332T	3.3K 1/4W [M]	R416	ERDS2TJ102T	1K 1/4W [M]	R477	ERDS2TJ103T	10K 1/4W [M]
R114	ERDS2TJ562T	5.6K 1/4W [M]	R301	ERDS2TJ750T	75 1/4W [M]	R417	ERDS2TJ473T	47K 1/4W [M]	R478	ERDS2TJ104T	100K 1/4W [M]
R115	ERDS2TJ561T	560 1/4W [M]	R302	ERDS2TJ750T	75 1/4W [M]	R418	ERDS2TJ473T	47K 1/4W [M]	R479	ERDS2TJ393T	39K 1/4W [M]
R116	ERDS2TJ102T	1K 1/4W [M]	R303	ERDS2TJ750T	75 1/4W [M]	R419	ERDS2TJ104T	100K 1/4W [M]	R480	ERDS2TJ393T	39K 1/4W [M]
R117	ERDS2TJ473T	47K 1/4W [M]	R341	ERDS2TJ103T	10K 1/4W [M]	R420	ERDS2TJ104T	100K 1/4W [M]	R481	ERDS2TJ393T	39K 1/4W [M]
R118	ERDS2TJ562T	5.6K 1/4W [M]	R342	ERDS2TJ104T	100K 1/4W [M]	R421	ERDS2TJ104T	100K 1/4W [M]	R485	ERDS2TJ104T	100K 1/4W [M]
R119	ERDS2TJ183T	18K 1/4W [M]	R343	ERDS2TJ104T	100K 1/4W [M]	R422	ERDS2TJ104T	100K 1/4W [M]	R486	ERDS2TJ102T	1K 1/4W [M]
R120	ERDS2TJ473T	47K 1/4W [M]	R344	ERDS2TJ104T	100K 1/4W [M]	R423	ERDS2TJ102T	1K 1/4W [M]	R491	ERDS2TJ102T	1K 1/4W [M]
R121	ERDS2TJ332T	3.3K 1/4W [M]	R345	ERDS2TJ103T	10K 1/4W [M]	R424	ERDS2TJ102T	1K 1/4W [M]	R492	ERDS2TJ102T	1K 1/4W [M]
R122	ERDS2TJ272T	2.7K 1/4W [M]	R346	ERDS2TJ103T	10K 1/4W [M]	R425	ERDS2TJ103T	10K 1/4W [M]	R493	ERDS2TJ102T	1K 1/4W [M]
R124	ERDS2TJ301T	300 1/4W [M]	R347	ERDS2TJ104T	100K 1/4W [M]	R426	ERDS2TJ103T	10K 1/4W [M]	R494	ERDS2TJ102T	1K 1/4W [M]
R125	ERDS2TJ472T	4.7K 1/4W [M]	R348	ERDS2TJ104T	100K 1/4W [M]	R427	ERDS2TJ103T	10K 1/4W [M]	R501	ERDS2TJ222T	2.2K 1/4W [M]
R126	ERDS2TJ472T	4.7K 1/4W [M]	R349	ERDS2TJ104T	100K 1/4W [M]	R428	ERDS2TJ332T	3.3K 1/4W [M]	R502	ERDS2TJ222T	2.2K 1/4W [M]
R127	ERDS2TJ103T	10K 1/4W [M]	R350	ERDS2TJ104T	100K 1/4W [M]	R433	ERDS2TJ102T	1K 1/4W [M]	R503	ERDS2TJ103T	10K 1/4W [M]
R128	ERDS2TJ820T	82 1/4W [M]	R351	ERDS2TJ104T	100K 1/4W [M]	R434	ERDS2TJ102T	1K 1/4W [M]	R504	ERDS2TJ103T	10K 1/4W [M]
R129	ERDS2TJ473T	47K 1/4W [M]	R352	ERDS2TJ104T	100K 1/4W [M]	R435	ERDS2TJ473T	47K 1/4W [M]	R505	ERDS2TJ103T	10K 1/4W [M]
R130	ERDS2TJ102T	1K 1/4W [M]	R359	ERDS2TJ750T	75 1/4W [M]	R440	ERDS1FVJ560T \triangle	56 1/2W [M]	R506	ERDS2TJ103T	10K 1/4W [M]
R131	ERDS2TJ102T	1K 1/4W [M]	R362	ERDS2TJ750T	75 1/4W [M]	R441	ERDS2TJ473T	47K 1/4W [M]	R508	ERDS1FVJ2R2T \triangle	2.2 1/2W [M]
R132	ERDS2TJ103T	10K 1/4W [M]	R367	ERDS2TJ102T	1K 1/4W [M]	R442	ERDS2TJ473T	47K 1/4W [M]	R509	ERDS2TJ103T	10K 1/4W [M]
R133	ERDS2TJ102T	1K 1/4W [M]	R368	ERDS2TJ102T	1K 1/4W [M]	R443	ERDS1FVJ560T \triangle	56 1/2W [M]	R510	ERDS2TJ103T	10K 1/4W [M]
R134	ERDS2TJ102T	1K 1/4W [M]	R369	ERDS2TJ182T	1.8K 1/4W [M]	R451	ERDS2TJ224T	220K 1/4W [M]	R511	ERDS2TJ471T	470 1/4W [M]
R135	ERDS2TJ102T	1K 1/4W [M]	R370	ERDS2TJ182T	1.8K 1/4W [M]	R452	ERDS2TJ224T	220K 1/4W [M]	R512	ERDS2TJ471T	470 1/4W [M]
R136	ERDS2TJ102T	1K 1/4W [M]	R371	ERD2FCVG220T	22 1/4W [M]	R453	ERDS2TJ391T	390 1/4W [M]	R513	ERDS2TJ474T	470K 1/4W [M]
R137	ERDS2TJ102T	1K 1/4W [M]	R372	ERD2FCVG220T	22 1/4W [M]	R454	ERDS2TJ391T	390 1/4W [M]	R514	ERDS2TJ474T	470K 1/4W [M]
R139	ERDS2TJ272T	2.7K 1/4W [M]	R373	ERDS2TJ103T	10K 1/4W [M]	R455	ERDS2TJ583T	56K 1/4W [M]	R515	ERDS2TJ474T	470K 1/4W [M]
R140	ERDS2TJ272T	2.7K 1/4W [M]	R374	ERDS2TJ103T	10K 1/4W [M]	R456	ERDS2TJ583T	56K 1/4W [M]	R516	ERDS2TJ474T	470K 1/4W [M]
R141	ERDS2TJ102T	1K 1/4W [M]	R375	ERDS2TJ103T	10K 1/4W [M]	R457	ERDS2TJ271T	270 1/4W [M]	R517	ERDS2TJ182T	1.8K 1/4W [M]
R142	ERDS2TJ102T	1K 1/4W [M]	R401	ERDS2TJ102T	1K 1/4W [M]	R458	ERDS2TJ271T	270 1/4W [M]	R518	ERDS2TJ182T	1.8K 1/4W [M]
R143	ERDS2TJ222T	2.2K 1/4W [M]	R402	ERDS2TJ102T	1K 1/4W [M]	R459	ERDS2TJ680T	68 1/4W [M]	R519	ERDS2TJ332T	3.3K 1/4W [M]
R144	ERDS2TJ222T	2.2K 1/4W [M]	R405	ERDS2TJ102T	1K 1/4W [M]	R460	ERDS2TJ680T	68 1/4W [M]	R520	ERDS2TJ332T	3.3K 1/4W [M]
R145	ERDS2TJ821T	820 1/4W [M]	R406	ERDS2TJ102T	1K 1/4W [M]	R461	ERDS2TJ184T	180K 1/4W [M]	R521	ERDS2TJ223T	22K 1/4W [M]

Ref No.	Part No.	Values & Remarks	Ref No.	Part No.	Values & Remarks	Ref No.	Part No.	Values & Remarks	Ref No.	Part No.	Values & Remarks
R522	ERDS2TJ223T	22K 1/4W [M]	R595	ERDS2TJ102T	1K 1/4W [M]	R647	ERDS2TJ221T	220 1/4W [M]	R722	ERDS2TJ123T	12K 1/4W [M]
R523	ERDS2TJ392T	3.9K 1/4W [M]	R596	ERDS2TJ102T	1K 1/4W [M]	R648	ERDS2TJ683T	68K 1/4W [M]	R723	ERDS1FVJ3R9T Δ	3.9 1/2W [M]
R524	ERDS2TJ392T	3.9K 1/4W [M]	R597	ERDS2TJ102T	1K 1/4W [M]	R649	ERDS2TJ104T	100K 1/4W [M]	R724	ERDS1FVJ3R9T Δ	3.9 1/2W [M]
R525	ERDS2TJ222T	2.2K 1/4W [M]	R598	ERDS2TJ102T	1K 1/4W [M]	R651	ERDS2TJ102T	1K 1/4W [M]	R725	ERDS2TJ821T	820 1/4W [M]
R526	ERDS2TJ222T	2.2K 1/4W [M]	R603	ERDS2TJ182T	1.8K 1/4W [M]	R652	ERDS2TJ102T	1K 1/4W [M]	R726	ERD25FVJ151T	150 1/4W [M]
R527	ERDS2TJ122T	1.2K 1/4W [M]	R604	ERDS2TJ182T	1.8K 1/4W [M]	R653	ERDS2TJ563T	56K 1/4W [M]	R727	ERD25FVJ151T	150 1/4W [M]
R528	ERDS2TJ122T	1.2K 1/4W [M]	R605	ERDS2TJ221T	220 1/4W [M]	R654	ERDS2TJ563T	56K 1/4W [M]	R728	ERDS2TJ684T	680K 1/4W [M]
R529	ERDS2TJ273T	27K 1/4W [M]	R606	ERDS2TJ221T	220 1/4W [M]	R655	ERDS2TJ182T	1.8K 1/4W [M]	R729	ERDS2TJ684T	680K 1/4W [M]
R530	ERDS2TJ273T	27K 1/4W [M]	R607	ERDS2TJ563T	56K 1/4W [M]	R656	ERDS2TJ182T	1.8K 1/4W [M]	R730	ERDS1FVJ8R2T Δ	8.2 1/2W [M]
R531	ERDS2TJ332T	3.3K 1/4W [M]	R608	ERDS2TJ563T	56K 1/4W [M]	R657	ERDS2TJ563T	56K 1/4W [M]	R754	ERDS2TJ102T	1K 1/4W [M]
R532	ERDS2TJ332T	3.3K 1/4W [M]	R609	ERDS2TJ470T	47 1/4W [M]	R658	ERDS2TJ563T	56K 1/4W [M]	R756	ERDS2TJ222T	2.2K 1/4W [M]
R533	ERDS2TJ473T	47K 1/4W [M]	R610	ERDS2TJ470T	47 1/4W [M]	R659	ERDS2TJ221T	220 1/4W [M]	R771	ERDS2TJ104T	100K 1/4W [M]
R534	ERDS2TJ473T	47K 1/4W [M]	R611	ERDS1FVJ100T Δ	10 1/2W [M]	R660	ERDS2TJ221T	220 1/4W [M]	R773	ERDS2TJ103T	10K 1/4W [M]
R535	ERDS2TJ272T	2.7K 1/4W [M]	R612	ERDS1FVJ100T Δ	10 1/2W [M]	R661	ERDS1FVJ100T Δ	10 1/2W [M]	R774	ERDS2TJ155T	1.5M 1/4W [M]
R536	ERDS2TJ272T	2.7K 1/4W [M]	R613	ERDS2TJ152T	1.5K 1/4W [M]	R662	ERDS1FVJ100T Δ	10 1/2W [M]	R775	ERDS2TJ331T	330 1/4W [M]
R537	ERDS2TJ103T	10K 1/4W [M]	R614	ERDS2TJ152T	1.5K 1/4W [M]	R663	ERDS2TJ470T	47 1/4W [M]	R776	ERDS1FVJ150T Δ	15 1/2W [M]
R538	ERDS2TJ103T	10K 1/4W [M]	R615	ERDS2TJ681T	680 1/4W [M]	R664	ERDS2TJ470T	47 1/4W [M]	R777	ERDS2TJ154T	150K 1/4W [M]
R543	ERDS2TJ102T	1K 1/4W [M]	R616	ERD25FVJ820T	82 1/4W [M]	R665	ERDS2TJ102T	1K 1/4W [M]	R778	ERDS2TJ472T	4.7K 1/4W [M]
R544	ERDS2TJ102T	1K 1/4W [M]	R617	ERD25FVJ820T	82 1/4W [M]	R666	ERDS2TJ102T	1K 1/4W [M]	R779	ERDS2TJ103T	10K 1/4W [M]
R545	ERDS2TJ684T	680K 1/4W [M]	R618	ERD25FVJ820T	82 1/4W [M]	R667	ERDS2TJ184T	180K 1/4W [M]	R781	ERDS2TJ222T	2.2K 1/4W [M]
R546	ERDS2TJ223T	22K 1/4W [M]	R619	ERD25FVJ820T	82 1/4W [M]	R668	ERDS2TJ154T	150K 1/4W [M]	R782	ERDS2TJ390T	39 1/4W [M]
R550	ERDS2TJ103T	10K 1/4W [M]	R620	ERD25FVJ220T	22 1/4W [M]	R669	ERDS2TJ563T	56K 1/4W [M]	R784	ERDS2TJ154T	150K 1/4W [M]
R551	ERDS2TJ102T	1K 1/4W [M]	R621	ERDS2TJ682T	6.8K 1/4W [M]	R670	ERDS2TJ563T	56K 1/4W [M]	R786	ERDS2TJ154T	150K 1/4W [M]
R552	ERDS2TJ102T	1K 1/4W [M]	R622	ERDS2TJ682T	6.8K 1/4W [M]	R671	ERD25FVJ181T	180 1/4W [M]	R791	ERDS2TJ123T	12K 1/4W [M]
R553	ERDS2TJ104T	100K 1/4W [M]	R623	ERDS2TJ682T	6.8K 1/4W [M]	R672	ERD25FVJ181T	180 1/4W [M]	R792	ERDS2TJ123T	12K 1/4W [M]
R554	ERDS2TJ104T	100K 1/4W [M]	R624	ERD25FVJ4R7T	4.7 1/4W [M]	R673	ERDS2TJ274T	270K 1/4W [M]	R793	ERDS2TJ123T	12K 1/4W [M]
R555	ERDS2TJ223T	22K 1/4W [M]	R625	ERG1SJ101E Δ	100 1W [M]	R674	ERDS2TJ684T	680K 1/4W [M]	R794	ERDS2TJ123T	12K 1/4W [M]
R556	ERDS2TJ223T	22K 1/4W [M]	R626	ERG1SJ101E Δ	100 1W [M]	R675	ERDS2TJ564T	560K 1/4W [M]	R795	ERDS2TJ223T	22K 1/4W [M]
R557	ERDS2TJ821T	820 1/4W [M]	R627	ERG1SJ101E Δ	100 1W [M]	R676	ERDS2TJ101T	100 1/4W [M]	R797	ERDS2TJ223T	22K 1/4W [M]
R558	ERDS2TJ821T	820 1/4W [M]	R628	ERG1SJ101E Δ	100 1W [M]	R677	ERDS2TJ473T	47K 1/4W [M]	R798	ERDS2TJ223T	22K 1/4W [M]
R561	ERDS2TJ102T	1K 1/4W [M]	R629	ERDS2TJ102T	1K 1/4W [M]	R678	ERDS2TJ473T	47K 1/4W [M]	R799	ERDS2TJ682T	6.8K 1/4W [M]
R562	ERDS2TJ102T	1K 1/4W [M]	R630	ERDS2TJ124T	120K 1/4W [M]	R689	ERDS2TJ821T	820 1/4W [M]	R891	ERDS2TJ103T	10K 1/4W [M]
R563	ERDS2TJ104T	100K 1/4W [M]	R631	ERDS2TJ154T	150K 1/4W [M]	R690	ERDS2TJ821T	820 1/4W [M]	R892	ERDS2TJ103T	10K 1/4W [M]
R564	ERDS2TJ104T	100K 1/4W [M]	R632	ERDS2TJ184T	180K 1/4W [M]	R698	ERDS2TJ152T	1.5K 1/4W [M]	R893	ERDS2TJ103T	10K 1/4W [M]
R565	ERDS2TJ223T	22K 1/4W [M]	R633	ERDS2TJ473T	47K 1/4W [M]	R699	ERDS2TJ152T	1.5K 1/4W [M]	R894	ERDS2TJ103T	10K 1/4W [M]
R566	ERDS2TJ103T	10K 1/4W [M]	R634	ERDS2TJ274T	270K 1/4W [M]	R703	ERDS1FVJ3R9T Δ	3.9 1/2W [M]	R901	ERDS2TJ102T	1K 1/4W [M]
R567	ERDS2TJ821T	820 1/4W [M]	R635	ERDS2TJ154T	150K 1/4W [M]	R704	ERDS1FVJ3R9T Δ	3.9 1/2W [M]	R903	ERDS2TJ104T	100K 1/4W [M]
R568	ERDS2TJ681T	680 1/4W [M]	R636	ERDS2TJ473T	47K 1/4W [M]	R705	ERDS2TJ472T	4.7K 1/4W [M]	R905	ERDS2TJ181T	180 1/4W [M]
R571	ERDS2TJ223T	22K 1/4W [M]	R637	ERDS2TJ154T	150K 1/4W [M]	R706	ERDS2TJ102T	1K 1/4W [M]	R906	ERDS2TJ222T	2.2K 1/4W [M]
R572	ERDS2TJ223T	22K 1/4W [M]	R638	ERDS2TJ154T	150K 1/4W [M]	R707	ERD25FVJ221T	220 1/4W [M]	R907	ERDS2TJ104T	100K 1/4W [M]
R573	ERDS2TJ223T	22K 1/4W [M]	R639	ERDS2TJ104T	100K 1/4W [M]	R708	ERDS2TJ152T	1.5K 1/4W [M]	R908	ERDS2TJ104T	100K 1/4W [M]
R574	ERDS2TJ223T	22K 1/4W [M]	R640	ERDS2TJ681T	680 1/4W [M]	R709	ERDS2TJ1R5T	1.5 1/4W [M]	R909	ERDS2TJ473T	47K 1/4W [M]
R575	ERDS2TJ223T	22K 1/4W [M]	R641	ERDS2TJ104T	100K 1/4W [M]	R710	ERDS2TJ1R5T	1.5 1/4W [M]	R910	ERDS2TJ102T	1K 1/4W [M]
R576	ERDS2TJ223T	22K 1/4W [M]	R642	ERDS2TJ182T	1.8K 1/4W [M]	R711	ERDS2TJ752T	7.5K 1/4W [M]	R911	ERDS2TJ104T	100K 1/4W [M]
R583	ERDS2TJ272T	2.7K 1/4W [M]	R643	ERDS2TJ563T	56K 1/4W [M]	R712	ERDS2TJ682T	6.8K 1/4W [M]	R913	ERDS2TJ103T	10K 1/4W [M]
R584	ERDS2TJ272T	2.7K 1/4W [M]	R644	ERDS1FVJ100T Δ	10 1/2W [M]	R713	ERDS2TJ390T	39 1/4W [M]	R915	ERDS2TJ104T	100K 1/4W [M]
R585	ERDS2TJ103T	10K 1/4W [M]	R645	ERDS2TJ470T	47 1/4W [M]	R714	ERDS2TJ390T	39 1/4W [M]	R917	ERDS2TJ103T	10K 1/4W [M]
R586	ERDS2TJ103T	10K 1/4W [M]	R646	ERDS2TJ332T	3.3K 1/4W [M]	R721	ERD25FVJ221T	220 1/4W [M]	R918	ERDS2TJ102T	1K 1/4W [M]

Ref No.	Part No.	Values & Remarks	Ref No.	Part No.	Values & Remarks	Ref No.	Part No.	Values & Remarks	Ref No.	Part No.	Values & Remarks
R919	ERDS2TJ102T	1K 1/4W [M]	R986	ERDS2TJ472T	4.7K 1/4W [M]	R1691	ERDS2TJ270T	27 1/4W [M]	C140	ECQB1H682JM3	6800P 50V [M]
R920	ERDS2TJ271T	270 1/4W [M]	R991	ERDS2TJ104T	100K 1/4W [M]	R1692	ERDS2TJ270T	27 1/4W [M]	C141	ECEA1HKA010B	1 50V [M]
R921	ERDS2TJ21T	120 1/4W [M]	R992	ERDS2TJ104T	100K 1/4W [M]	R1693	ERDS2TJ270T	27 1/4W [M]	C142	ECEA1HKA010B	1 50V [M]
R922	ERDS2TJ472T	4.7K 1/4W [M]	R993	ERDS2TJ104T	100K 1/4W [M]	R1694	ERDS2TJ270T	27 1/4W [M]	C143	ECEA1HKA010B	1 50V [M]
R924	ERDS2TJ103T	10K 1/4W [M]	R994	ERDS2TJ104T	100K 1/4W [M]	R1695	ERDS2TJ102T	1K 1/4W [M]	C144	ECEA1HKA010B	1 50V [M]
R927	ERDS2TJ181T	180 1/4W [M]	R995	ERDS2TJ104T	100K 1/4W [M]	R1696	ERDS2TJ102T	1K 1/4W [M]	C145	ECBT1H220JC5	22P 50V [M]
R929	ERDS2TJ101T	100 1/4W [M]	R996	ERDS2TJ104T	100K 1/4W [M]	R1699	ERDS2TJ332T	3.3K 1/4W [M]	C146	ECBT1H331KB5	330P 50V [M]
R930	ERDS2TJ101T	100 1/4W [M]	R997	ERDS2TJ101T	100 1/4W [M]				C147	ECBT1H102KB5	1000P 50V [M]
R931	ERDS2TJ271T	270 1/4W [M]	R998	ERDS2TJ101T	100 1/4W [M]				C148	ECBT1C103NS5	0.01 16V [M]
R932	ERDS2TJ271T	270 1/4W [M]	R1001	ERDS2TJ102T	1K 1/4W [M]				C149	ECBT1C103NS5	0.01 16V [M]
R933	ERDS2TJ271T	270 1/4W [M]	R1002	ERDS2TJ102T	1K 1/4W [M]	C101	ECBT1C103NS5	0.01 16V [M]	C150	ECBT1H104ZF5	0.1 50V [M]
R934	ERDS2TJ271T	270 1/4W [M]	R1003	ERDS2TJ102T	1K 1/4W [M]	C103	ECBT1C103NS5	0.01 16V [M]	C172	ECBT1H331KB5	330P 50V [M]
R935	ERDS2TJ271T	270 1/4W [M]	R1004	ERDS2TJ102T	1K 1/4W [M]	C104	ECBT1H102KB5	1000P 50V [M]	C173	ECEA1CKA220B	22 16V [M]
R936	ERDS2TJ271T	270 1/4W [M]	R1005	ERDS2TJ203T	20K 1/4W [M]	C105	ECBT1H470J5	47P 50V [M]	C174	ECEA1CKA101B	100 16V [M]
R937	ERDS2TJ271T	270 1/4W [M]	R1007	ERDS2TJ473T	47K 1/4W [M]	C106	ECBT1C103NS5	0.01 16V [M]	C175	ECBT1C103NS5	0.01 16V [M]
R939	ERDS2TJ271T	270 1/4W [M]	R1008	ERDS2TJ473T	47K 1/4W [M]	C107	ECBT1H473ZF5	0.047 50V [M]	C176	ECBT1C103NS5	0.01 16V [M]
R940	ERDS2TJ271T	270 1/4W [M]	R1009	ERDS2TJ332T	3.3K 1/4W [M]	C108	ECBT1H6R2KC5	8.2P 50V [M]	C181	ECBT1H471KB5	470P 50V [M]
R941	ERDS2TJ271T (Opr)	270 1/4W [M]	R1010	ERDS2TJ332T	3.3K 1/4W [M]	C109	ECBT1C103NS5	0.01 16V [M]	C196	ECBT1H102KB5	1000P 50V [M]
R941	ERDS2TJ472T(Main)	4.7K 1/4W [M]	R1011	ERDS2TJ332T	3.3K 1/4W [M]	C110	ECBT1C103NS5	0.01 16V [M]	C308	ECA0JM101B	100 6.3V [M]
R942	ERDS2TJ181T	180 1/4W [M]	R1012	ERDS2TJ102T	1K 1/4W [M]	C111	ECEA1EKA4R7B	4.7 25V [M]	C309	ECA0JM101B	100 6.3V [M]
R943	ERDS2TJ102T	1K 1/4W [M]	R1013	ERDS2TJ103T	10K 1/4W [M]	C112	ECBT1C103NS5	0.01 16V [M]	C311	ECEA1EU4R7B	4.7 25V [M]
R944	ERDS2TJ104T	100K 1/4W [M]	R1014	ERDS2TJ104T	100K 1/4W [M]	C113	ECBT1H102KB5	1000P 50V [M]	C312	ECEA1EU4R7B	4.7 25V [M]
R945	ERDS2TJ104T	100K 1/4W [M]	R1015	ERD2FCVJ4R7T	4.7 1/4W [M]	C114	ECEA1HKA3R3B	3.3 50V [M]	C329	ECBT1H470J5	47P 50V [M]
R946	ERDS2TJ103T	10K 1/4W [M]	R1051	ERDS2TJ393T	39K 1/4W [M]	C115	ECEA1EKA4R7B	4.7 25V [M]	C330	ECBT1H470J5	47P 50V [M]
R948	ERDS2TJ103T	10K 1/4W [M]	R1052	ERDS2TJ105T	1M 1/4W [M]	C116	ECBT1C822MS5	8200P 16V [M]	C351	ECEA0JKA101B	100 6.3V [M]
R949	ERDS2TJ103T	10K 1/4W [M]	R1053	ERDS2TJ102T	1K 1/4W [M]	C117	ECQB1H471JM3	470P 50V [M]	C352	ECEA0JKA101B	100 6.3V [M]
R950	ERDS2TJ102T	1K 1/4W [M]	R1055	ERDS2TJ224T	220K 1/4W [M]	C118	ECQB1H103JM3	0.01 50V [M]	C354	ECBT1H104ZF5	0.1 50V [M]
R951	ERDS2TJ122T	1.2K 1/4W [M]	R1056	ERDS2TJ153T	15K 1/4W [M]	C119	ECQB1H103JM3	0.01 50V [M]	C355	ECBT1H104ZF5	0.1 50V [M]
R952	ERDS2TJ152T	1.5K 1/4W [M]	R1061	ERDS2TJ222T	2.2K 1/4W [M]	C120	ECEA1HKA010B	1 50V [M]	C357	ECBT1E103ZF5	0.01 25V [M]
R953	ERDS2TJ182T	1.8K 1/4W [M]	R1062	ERDS2TJ273T	27K 1/4W [M]	C121	ECEA1HKA010B	1 50V [M]	C358	ECBT1E103ZF5	0.01 25V [M]
R954	ERDS2TJ222T	2.2K 1/4W [M]	R1063	ERDS2TJ332T	3.3K 1/4W [M]	C122	ECEA1HKA2R2B	2.2 50V [M]	C373	ECEA1CKA470B	47 16V [M]
R955	ERDS2TJ332T	3.3K 1/4W [M]	R1151	ERDS2TJ473T	47K 1/4W [M]	C123	ECEA1HKA010B	1 50V [M]	C374	ECEA1CKA470B	47 16V [M]
R956	ERDS2TJ472T	4.7K 1/4W [M]	R1152	ERDS2TJ473T	47K 1/4W [M]	C124	ECBT1H102KB5	1000P 50V [M]	C375	ECEA1CKA470B	47 16V [M]
R957	ERDS2TJ682T	6.8K 1/4W [M]	R1154	ERDS2TJ333T	33K 1/4W [M]	C125	ECBT1H150JC5	15P 50V [M]	C381	ECEA1HKA3R3B	3.3 50V [M]
R958	ERDS2TJ123T	12K 1/4W [M]	R1155	ERDS2TJ393T	39K 1/4W [M]	C126	ECBT1H104ZF5	0.1 50V [M]	C382	ECEA1HKA3R3B	3.3 50V [M]
R970	ERDS2TJ102T	1K 1/4W [M]	R1156	ERDS2TJ393T	39K 1/4W [M]	C127	ECEA1CKA220B	22 16V [M]	C383	ECEA1HKA3R3B	3.3 50V [M]
R971	ERDS2TJ122T	1.2K 1/4W [M]	R1158	ERDS2TJ104T	100K 1/4W [M]	C128	ECBT1C103NS5	0.01 16V [M]	C384	ECEA1HKA3R3B	3.3 50V [M]
R972	ERDS2TJ152T	1.5K 1/4W [M]	R1160	ERDS2TJ104T	100K 1/4W [M]	C129	ECEA0JKA101B	100 6.3V [M]	C385	ECEA1HKA3R3B	3.3 50V [M]
R973	ERDS2TJ182T	1.8K 1/4W [M]	R1681	ERDS2TJ270T	27 1/4W [M]	C130	ECEA0JKA101B	100 6.3V [M]	C386	ECEA1HKA3R3B	3.3 50V [M]
R974	ERDS2TJ222T	2.2K 1/4W [M]	R1682	ERDS2TJ270T	27 1/4W [M]	C131	ECBT1C103NS5	0.01 16V [M]	C387	ECEA1HKA3R3B	3.3 50V [M]
R977	ERDS2TJ102T	1K 1/4W [M]	R1683	ERDS2TJ270T	27 1/4W [M]	C132	ECBT1H102KB5	1000P 50V [M]	C388	ECEA1HKA3R3B	3.3 50V [M]
R978	ERDS2TJ102T	1K 1/4W [M]	R1684	ERDS2TJ270T	27 1/4W [M]	C133	ECBT1H150JC5	15P 50V [M]	C401	ECEA1HKA4R7B	4.7 50V [M]EB
R980	ERDS2TJ102T	1K 1/4W [M]	R1685	ERDS2TJ270T	27 1/4W [M]	C134	ECBT1H180JC5	18P 50V [M]	C401	ECEA1VKA4R7B	4.7 35V [M]EG E
R981	ERDS2TJ122T	1.2K 1/4W [M]	R1686	ERDS2TJ270T	27 1/4W [M]	C135	ECBT1C103MS5	0.01 16V [M]	C402	ECEA1HKA4R7B	4.7 50V [M]EB
R982	ERDS2TJ152T	1.5K 1/4W [M]	R1687	ERDS2TJ270T	27 1/4W [M]	C136	ECBT1C103MS5	0.01 16V [M]	C402	ECEA1VKA4R7B	4.7 35V [M]EG E
R983	ERDS2TJ182T	1.8K 1/4W [M]	R1688	ERDS2TJ270T	27 1/4W [M]	C137	ECBT1H561KB5	560P 50V [M]	C403	ECBT1E103ZF5	0.01 25V [M]
R984	ERDS2TJ222T	2.2K 1/4W [M]	R1689	ERDS2TJ270T	27 1/4W [M]	C138	ECBT1H561KB5	560P 50V [M]	C404	ECBT1E103ZF5	0.01 25V [M]
R985	ERDS2TJ332T	3.3K 1/4W [M]	R1690	ERDS2TJ270T	27 1/4W [M]	C139	ECQB1H682JM3	6800P 50V [M]	C405	ECBT1H101KB5	100P 50V [M]

Ref No.	Part No.	Values & Remarks	Ref No.	Part No.	Values & Remarks	Ref No.	Part No.	Values & Remarks	Ref No.	Part No.	Values & Remarks
C406	ECBT1H101KB5	100P 50V [M]	C473	ECBT1E103ZF5	0.01 25V [M]	C558	ECBT1E103ZF5	0.01 25V [M]	C642	ECBT1H821KB5	820P 50V [M]
C409	ECA1EM220B	22 25V [M]	C474	ECBT1E103ZF5	0.01 25V [M]	C559	ECEA1CKA100B	10 16V [M]	C643	ECCR1H180KC5	18P 50V [M]
C410	ECA1EM220B	22 25V [M]	C475	ECBT1H101KB5	100P 50V [M]	C560	ECEA1CKA100B	10 16V [M]	C644	ECQV1H104JZ3	0.1 50V [M]
C411	ECBT1H101KB5	100P 50V [M]	C482	ECEA1HKA3R3B	3.3 50V [M]	C561	ECEA1HKA3R3B	3.3 50V [M]	C645	ECQV1H104JZ3	0.1 50V [M]
C412	ECBT1H101KB5	100P 50V [M]	C483	ECBT1H101KB5	100P 50V [M]	C562	ECEA1HKA3R3B	3.3 50V [M]	C646	ECQE2334B117	0.33 250V [M]
C413	ECA1CM100B	10 16V [M]	C491	ECBT1H101KB5	100P 50V [M]	C563	ECBT1H101KB5	100P 50V [M]	C651	ECEA1HN3R3SB	3.3 50V [M]
C414	ECA1CM100B	10 16V [M]	C492	ECBT1H101KB5	100P 50V [M]	C564	ECBT1H101KB5	100P 50V [M]	C652	ECEA1HN3R3SB	3.3 50V [M]
C415	ECBT1E103ZF5	0.01 25V [M]	C493	ECBT1H101KB5	100P 50V [M]	C565	ECBT1H221KB5	220P 50V [M]	C653	ECBT1H681KB5	680P 50V [M]
C416	ECBT1E103ZF5	0.01 25V [M]	C494	ECBT1H101KB5	100P 50V [M]	C566	ECBT1H221KB5	220P 50V [M]	C654	ECBT1H681KB5	680P 50V [M]
C417	ECBT1H101KB5	100P 50V [M]	C503	ECEA0JKA101B	100 6.3V [M]	C567	ECBT1E103ZF5	0.01 25V [M]	C655	ECEA1JU220B	22 63V [M]
C418	ECBT1H101KB5	100P 50V [M]	C504	ECEA0JKA101B	100 6.3V [M]	C568	ECBT1E103ZF5	0.01 25V [M]	C656	ECEA1JU220B	22 63V [M]
C419	ECBT1H331KB5	330P 50V [M]	C505	ECFR1C104MR	0.1 16V [M]	C571	ECEA1HKA010B	1 50V [M]	C657	ECCR1H100K5	10P 50V [M]
C420	ECBT1H331KB5	330P 50V [M]	C506	ECFR1C104MR	0.1 16V [M]	C572	ECEA1HKA010B	1 50V [M]	C658	ECCR1H100K5	10P 50V [M]
C421	ECBT1H331KB5	330P 50V [M]	C511	ECEA1HKA3R3B	3.3 50V [M]	C573	ECBT1H680J5	68P 50V [M]	C659	ECBT1H221KB5	220P 50V [M]
C422	ECBT1H331KB5	330P 50V [M]	C512	ECEA1HKA3R3B	3.3 50V [M]	C574	ECBT1H680J5	68P 50V [M]	C660	ECBT1H221KB5	220P 50V [M]
C423	ECBT1H101KB5	100P 50V [M]	C513	ECBT1H150J5	15P 50V [M]	C575	ECEA1HKA010B	1 50V [M]	C661	ECQV1H104JZ3	0.1 50V [M]
C424	ECBT1H101KB5	100P 50V [M]	C514	ECBT1H150J5	15P 50V [M]	C576	ECBT1H680J5	68P 50V [M]	C662	ECQV1H104JZ3	0.1 50V [M]
C425	ECBT1H101KB5	100P 50V [M]	C515	ECBT1H221KB5	220P 50V [M]	C585	ECEA1CKA100B	10 16V [M]	C663	ECQV1H104JZ3	0.1 50V [M]
C426	ECBT1H101KB5	100P 50V [M]	C516	ECBT1H221KB5	220P 50V [M]	C586	ECEA1CKA100B	10 16V [M]	C664	ECQV1H104JZ3	0.1 50V [M]
C427	ECBT1H221KB5	220P 50V [M]	C517	ECBT1H330J5	33P 50V [M]	C601	ECA1JM330B	33 6.3V [M]	C665	ECBT1H681KB5	680P 50V [M]
C428	ECBT1H221KB5	220P 50V [M]	C518	ECBT1H330J5	33P 50V [M]	C602	ECA1JM330B	33 6.3V [M]	C666	ECBT1H681KB5	680P 50V [M]
C431	ECA1CM100B	10 16V [M]	C519	ECEA1VKA4R7B	4.7 35V [M]	C603	ECBT1H821KB5	820P 50V [M]	C667	ECEA2AU100B	10 100V [M]
C432	ECA1CM100B	10 16V [M]	C520	ECEA1VKA4R7B	4.7 35V [M]	C604	ECBT1H821KB5	820P 50V [M]	C668	ECEA2AU100B	10 100V [M]
C433	ECBT1H101KB5	100P 50V [M]	C521	ECEA1VKA4R7B	4.7 35V [M]	C607	ECCR1H180KC5	18P 50V [M]	C669	ECEA2AN2R2SB	2.2 100V [M]
C434	ECBT1H101KB5	100P 50V [M]	C522	ECEA1VKA4R7B	4.7 35V [M]	C608	ECCR1H180KC5	18P 50V [M]	C670	ECEA1JU220B	22 63V [M]
C440	ECBT1E103ZF5	0.01 25V [M]	C523	ECFR1E123KR	0.012 25V [M]	C611	ECQV1H104JZ3	0.1 50V [M]	C671	ECA1JM330B	33 6.3V [M]
C441	ECEA1HKN3R3B	3.3 50V [M]	C524	ECFR1E123KR	0.012 25V [M]	C612	ECQV1H104JZ3	0.1 50V [M]	C672	ECBT1H102KB5	1000P 50V [M]
C451	ECEA1VKA4R7B	4.7 35V [M]	C525	ECQV1H683JM3	0.068 50V [M]	C613	ECQV1H104JZ3	0.1 50V [M]	C673	ECEA2AU100B	10 100V [M]
C452	ECEA1VKA4R7B	4.7 35V [M]	C526	ECQV1H683JM3	0.068 50V [M]	C614	ECQV1H104JZ3	0.1 50V [M]	C691	ECBT1H102KB5	1000P 50V [M]
C453	ECBT1H100J5	10P 50V [M]	C527	ECBT1C562KR5	5600P 16V [M]	C615	ECBT1H103KB5	0.01 50V [M]	C698	ECKR1H181KB5	180P 50V [M]
C454	ECBT1H100J5	10P 50V [M]	C528	ECBT1C562KR5	5600P 16V [M]	C616	ECA1JM330B	33 6.3V [M]	C701	ECBT1E103ZF5	0.01 25V [M]
C455	ECBT1H102KB5	1000P 50V [M]	C529	ECQB1H273JM3	0.027 50V [M]	C617	ECEA2AN2R2SB	2.2 100V [M]	C702	ECQE2104KF3	0.1 250V [M]
C456	ECBT1H102KB5	1000P 50V [M]	C530	ECQB1H273JM3	0.027 50V [M]	C618	ECBT1H102KB5	1000P 50V [M]	C703	ECES75V752UM Δ	7500 75V [M]
C457	ECEA1AKA330B	33 10V [M]	C531	ECBT1E103ZF5	0.01 25V [M]	C619	ECA1EM101B	100 25V [M]	C704	ECES75V752UM Δ	7500 75V [M]
C458	ECEA1AKA330B	33 10V [M]	C532	ECBT1E103ZF5	0.01 25V [M]	C621	ECEA2AU100B	10 100V [M]	C705	ECES1VV472N Δ	4700 35V [M]
C459	ECFR1E223KR	0.022 25V [M]	C533	ECEA1CKA100B	10 16V [M]	C622	ECEA2AU100B	10 100V [M]	C706	ECES1VV472N Δ	4700 35V [M]
C460	ECFR1E223KR	0.022 25V [M]	C534	ECEA1CKA100B	10 16V [M]	C625	ECEA1HN100SB	10 50V [M]	C707	ECA1VM101B	100 35V [M]
C461	ECFR1E682KR	6800P 25V [M]	C535	ECBT1H104ZF5	0.1 50V [M]	C626	ECEA1HN100SB	10 50V [M]	C708	ECKR1H103ZF5	0.01 50V [M]
C462	ECFR1E682KR	6800P 25V [M]	C536	ECBT1H104ZF5	0.1 50V [M]	C631	ECKR1H223ZF5	0.022 50V [M]	C709	ECEA1CKA330B	33 16V [M]
C463	ECEA1VKA4R7B	4.7 35V [M]	C537	ECEA1CKA100B	10 16V [M]	C632	ECKR1H223ZF5	0.022 50V [M]	C710	ECBT1E103ZF5	0.01 25V [M]
C464	ECEA1VKA4R7B	4.7 35V [M]	C538	ECEA1CKA100B	10 16V [M]	C633	ECKR1H223ZF5	0.022 50V [M]	C711	ECKR1H103ZF5	0.01 50V [M]
C465	ECBT1E103ZF5	0.01 25V [M]	C551	ECEA1HKA3R3B	3.3 50V [M]	C634	ECKR1H223ZF5	0.022 50V [M]	C712	ECEA1HKA100B	10 50V [M]
C466	ECBT1E103ZF5	0.01 25V [M]	C552	ECEA1HKA3R3B	3.3 50V [M]	C635	ECKR1H223ZF5	0.022 50V [M]	C713	ECKR1H103ZF5	0.01 50V [M]
C469	ECBT1H181KB5	180P 50V [M]	C553	ECBT1H101KB5	100P 50V [M]	C637	ECKR1H223ZF5	0.022 50V [M]	C714	ECEA1EKA470B	47 25V [M]
C470	ECBT1H181KB5	180P 50V [M]	C554	ECBT1H101KB5	100P 50V [M]	C638	ECKR1H223ZF5	0.022 50V [M]	C715	ECEA1CKA101B	100 16V [M]
C471	ECEA1HKA4R7B	4.7 50V [M]EB	C555	ECBT1H221KB5	220P 50V [M]	C639	ECKR1H102KB5	1000P 50V [M]	C721	ECQE2104KF3	0.1 250V [M]
C471	ECEA1VKA4R7B	4.7 35V [M]EB	C556	ECBT1H221KB5	220P 50V [M]	C640	ECKR1H102KB5	1000P 50V [M]	C751	ECKWRS102MBC	1000P 400V [M]
C472	ECEA1VKA4R7B	4.7 35V [M]	C557	ECBT1E103ZF5	0.01 25V [M]	C641	ECA1JM330B	33 6.3V [M]	C752	ECKR1H103ZF5 Δ	0.01 50V [M]

Ref No.	Part No.	Values & Remarks	Ref No.	Part No.	Values & Remarks	Ref No.	Part No.	Values & Remarks	Ref No.	Part No.	Values & Remarks
C753	ECA1EM102E Δ	1000 25V [M]	C962	ECBT1H561KB5	560P 50V [M]	C1040	ECEA1CKA100B	10 16V [M]			
C754	ECBT1E103ZF5	0.01 25V [M]	C963	ECBT1H102KB5	1000P 50V [M]	C1041	ECBT1E103ZF5	0.01 25V [M]			
C755	ECA1CM470B	47 16V [M]	C991	ECBT1H101KB5	100P 50V [M]	C1051	ECEA1HKA2R2B	2.2 50V [M]			
C757	ECA1CM100B	10 16V [M]	C992	ECBT1H101KB5	100P 50V [M]	C1052	ECEA1HKAR33B	0.33 50V [M]			
C756	ECEA1AKA101B	100 10V [M]	C993	ECBT1H101KB5	100P 50V [M]	C1053	ECEA1HKA3R3B	3.3 50V [M]			
C771	ECEA1HKA4R7B	4.7 50V [M]	C994	ECBT1H101KB5	100P 50V [M]	C1054	ECEA0JU221B	220 6.3V [M]			
C772	ECEA1HKA4R7B	4.7 50V [M]	C995	ECBT1H101KB5	100P 50V [M]	C1055	ECEA1HKAR47B	0.47 50V [M]			
C773	ECBT1E223ZF5	0.022 25V [M]	C996	ECBT1H101KB5	100P 50V [M]	C1056	ECFR1E823KR	0.082 25V [M]			
C774	ECEA0JKA101B	100 6.3V [M]	C997	ECEA1CKA100B	10 16V [M]	C1057	ECFR1E332KR	3300P 25V [M]			
C775	ECEA1CKA100B	10 16V [M]	C998	ECBT1E103ZF5	0.01 25V [M]	C1058	ECFR1E823KR	0.082 25V [M]			
C776	ECEA1HKA010B	1 50V [M]	C1001	ECEA1HKA010B	1 50V [M]	C1059	ECEA1CKA101B	100 16V [M]			
C891	ECEA1CKA100B	10 16V [M]	C1002	ECEA1HKA010B	1 50V [M]	C1060	ECBT1E223ZF5	0.022 25V [M]			
C894	ECBT1H101KB5	100P 50V [M]	C1003	ECEA1HKA3R3B	3.3 50V [M]	C1062	ECBT1E223ZF5	0.022 25V [M]			
C895	ECBT1H101KB5	100P 50V [M]	C1004	ECEA1HKA3R3B	3.3 50V [M]	C1063	ECEA1CKA101B	100 16V [M]			
C901	ECEA0JU102B Δ	1000 6.3V [M]	C1005	ECEA1HKA010B	1 50V [M]	C1064	ECEA1HKA010B	1 50V [M]			
C902	ECBT1H104ZF5	0.1 50V [M]	C1007	ECFR1E223KR	0.022 25V [M]	C1065	ECBT1H681KB5	680P 50V [M]			
C903	ECBT1E103ZF5	0.01 25V [M]	C1008	ECFR1E473KR	0.047 25V [M]	C1067	ECBT1C152KR5	1500P 16V [M]			
C904	ECEA0JU102B Δ	1000 6.3V [M]	C1009	ECEA0JU221B	220 6.3V [M]	C1068	ECBT1C152KR5	1500P 16V [M]			
C905	ECBT1E103ZF5	0.01 25V [M]	C1010	ECEA1CKA100B	10 16V [M]	C1151	ECEA1HKA010B	1 50V [M]			
C906	ECEA0JKA101B	100 6.3V [M]	C1011	ECEA1CKA100B	10 16V [M]	C1152	ECFR1C683KR	0.068 16V [M]			
C908	ECBT1E103ZF5	0.01 25V [M]	C1012	ECEA1CKA100B	10 16V [M]	C1153	ECFR1C273KR	0.027 16V [M]			
C909	ECEA1VKA220B	22 35V [M]	C1013	ECEA1CKA100B	10 16V [M]	C1154	ECEA1HKA4R7B	4.7 50V [M]EB			
C910	ECEA1VKA220B	22 35V [M]	C1014	ECEA0JU221B	220 6.3V [M]	C1154	ECEA1VKA4R7B	4.7 35V [M]EE			
C911	ECEA1VKA220B	22 35V [M]	C1015	ECQV1H104JM3	0.1 50V [M]	C1156	ECBT1E103ZF5	0.01 25V [M]			
C912	ECEA1VKA220B	22 35V [M]	C1016	ECQV1H104JM3	0.1 50V [M]	C1157	ECBT1E103ZF5	0.01 25V [M]			
C913	ECEA1VKA100B	10 35V [M]	C1017	ECEA1HKAR47B	0.47 50V [M]	C1159	ECEA1HKA010B	1 50V [M]			
C914	ECEA1VKA100B	10 35V [M]	C1018	ECEA1HKA4R7B	4.7 50V [M]	C1161	ECBT1H101KB5	100P 50V [M]			
C916	ECEA1HKA010B	1 50V [M]	C1019	ECEA1HKAR47B	0.47 50V [M]	C1683	ECBT1C332KR5	3300P 16V [M]			
C917	ECEA0JKA101B	100 6.3V [M]	C1020	ECEA1HKA4R7B	4.7 50V [M]	C1684	ECBT1C332KR5	3300P 16V [M]			
C918	ECEA0JKA101B	100 6.3V [M]	C1021	ECEA1HKAR15B	0.15 50V [M]	C1685	ECBT1E103ZF5	0.01 25V [M]			
C920	ECEA1HKA010B	1 50V [M]	C1022	ECEA1HKA3R3B	3.3 50V [M]						
C921	ECBT1H331KB5	330P 50V [M]	C1023	ECQV1H154JM3	0.15 50V [M]						
C922	ECBT1H331KB5	330P 50V [M]	C1024	ECQV1H154JM3	0.15 50V [M]						
C923	ECBT1H331KB5	330P 50V [M]	C1025	ECEA1HKA3R3B	3.3 50V [M]						
C924	ECBT1H331KB5	330P 50V [M]	C1026	ECEA1HKAR15B	0.15 50V [M]						
C925	ECBT1H331KB5	330P 50V [M]	C1027	ECEA1HKA4R7B	4.7 50V [M]						
C926	ECBT1H331KB5	330P 50V [M]	C1028	ECEA1HKAR47B	0.47 50V [M]						
C927	ECBT1H331KB5	330P 50V [M]	C1029	ECEA1HKA4R7B	4.7 50V [M]						
C928	ECBT1H331KB5	330P 50V [M]	C1030	ECEA1HKAR47B	0.47 50V [M]						
C929	ECBT1H331KB5	330P 50V [M]	C1031	ECQV1H104JM3	0.1 50V [M]						
C930	ECBT1H331KB5	330P 50V [M]	C1032	ECQV1H104JM3	0.1 50V [M]						
C932	ECBT1H101KB5	100P 50V [M]	C1033	ECEA0JKA470B	47 6.3V [M]						
C933	ECBT1H101KB5	100P 50V [M]	C1034	ECQV1H474JM3	0.47 50V [M]						
C943	ECBT1H331KB5	330P 50V [M]	C1035	ECBT1H681KB5	680P 50V [M]						
C944	ECEA1CKA100B	10 16V [M]	C1036	ECBT1H101KB5	100P 50V [M]						
C945	ECBT1E103ZF5	0.01 25V [M]	C1037	ECBT1H101KB5	100P 50V [M]						
C946	ECBT1H470J5	47P 50V [M]	C1038	ECBT1H101KB5	100P 50V [M]						
C947	ECBT1H470J5	47P 50V [M]	C1039	ECEA1CU101B	100 16V [M]						

■ Packing Materials & Accessories

Notes :

- * Important safety notice : Components identified by \triangle mark have special characteristics important for safety. Furthermore, special parts which have purposes of fire-retardant (resistors), high-quality sound (capacitors), low-noise (resistors), etc. are used. When replacing any of components, be sure to use only manufacturer's specified parts shown in the parts list.
- * The parenthesized in the Remarks columns specify the areas. (Refer to the cover page for area.)
- * Parts without these indication can be used for all areas.
- * The mark "(SF)" denotes standard part.
- * [M] in Remarks column indicates parts supplied by MESA.
- * Remote Control Unit : Supply period for three years from termination of production.
- * Reference for O/I book languages are as follows :

Ar : Arabic	Cf : Canadian French	CO : Chinese (old)	Cn : Chinese (new)	Cz : Czech	Da : Danish
Du : Dutch	En : English	Fr : French	Ge : German	It : Italian	Ko : Korean
Po : Polish	Ru : Russian	Sp : Spanish	Sw : Swedish		

Ref No.	Part No.	Part Name & Description	Remarks	Ref No.	Part No.	Part Name & Description	Remarks	Ref No.	Part No.	Part Name & Description	Remarks
		PACKING MATERIALS		A1-1	UR64EC1987B	R/C BATTERY COVER	[M]	A3	RQT4906-D	O/I BOOK RC (Ge/It/Fr)	[M]EG
				A2	RJA0019-2K	AC CORD (SF) \triangle	[M]EG E	A3	RQT4907-H	O/I BOOK RC (Du/Da)	[M]EG
P1	RPN0966-2	POLYFOAM	[M]	A2	VJA0733	AC CORD (SF) \triangle	[M]EB	A3	RQT4908-B	O/I BOOK RC (En)	[M]EB
P2	RPFX0005	MIRAMAT BAG	[M]	A3	RQT4769-E	O/I BOOK (En/Sp/Sw)	[M]E	A4	RSA0007	FM ANTENNA	[M]
P3	RPG4342	PACKING CASE	[M]E	A3	RQT4770-R	O/I BOOK (Ru/Cz/Po)	[M]E	A5	RSA0010	LOOP ANT UNIT	[M]
P3	RPG4343	PACKING CASE	[M]EB EG	A3	RQT4771-D	O/I BOOK (Ge/It/Fr)	[M]EG	A6	SJP9009	ANT ADAPTER	[M]EB
		ACCESSORIES		A3	RQT4772-H	O/I BOOK (Du/Da)	[M]EG				
				A3	RQT4773-B	O/I BOOK (En)	[M]EB				
				A3	RQT4904-E	O/I BOOK RC (En/Sp/Sw)	[M]E				
A1	EUR646497	REMOTE CONTROL	[M]	A3	RQT4905-R	O/I BOOK RC (Ru/Cz/Po)	[M]E				

■ Packaging

