

Service Manual

AV Control Stereo Receiver

Receiver

SA-AX920

Simplified



Colour
(K) Black Type

Suffix for Model No.	Area	Colour
(P)	U.S.A.	(K)
(PC)	Canada	

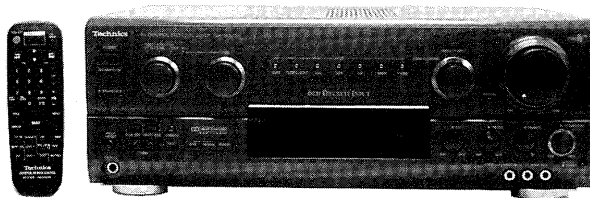

* Manufactured under license from Dolby Laboratories Licensing Corporation. Additionally licensed under one or more of the following patents: U.S. numbers 3,632,886, 3,746,792 and 3,959,590; Canadian numbers 1,004,603 and 1,037,877. "Dolby" and the double-D symbol are trade marks of Dolby Laboratories Licensing Corporation.

Please file and use this Service Manual together with the Service Manual for Model No. SA-AX720 (P,PC) Order No. MD9712150C1.

Note : This Simplified Service Manual is provided to indicate the main difference between the original Model No. SA-AX720 (P) and the subsequent Model No. SA-AX920 (P,PC).

Specifications

Amplifier Section

Rated minimum sine wave RMS power output
20 Hz–20 kHz both channels driven
0.05% total harmonic distortion 100 W per channel (8Ω)

1 kHz continuous power output
both channels driven 0.05% total harmonic distortion 105 W per channel (8Ω)

Total harmonic distortion
Rated power at 20 Hz – 20 kHz 0.05% (8Ω)
Half power at 1 kHz 0.03% (8Ω)

Power output at the Dolby Pro Logic operation
0.9% at 1 kHz,
Front 2 X 100 W (8Ω)
Center 100 W (8Ω)
Surround 2 X 100 W (8Ω)
Subwoofer 100 W (8Ω)

Low frequency damping factor 30 (8Ω)

Load impedance
Front
A or B 4 - 8 Ω
A and B 8 Ω
Center 8 Ω
Surround 8 Ω
Subwoofer 8 Ω

Dynamic headroom 2 dB (8Ω)

Frequency response
PHONO RIAA standard curve ± 0.8 dB
CD,TAPE,DVD,VCR1,TV/DSS/VCR2 10 Hz – 70 kHz, ± 3 dB

Input sensitivity
PHONO 0.4 mV (3mV, IHF '66)
CD,TAPE,DVD,VCR1,TV/DSS/VCR2 27 mV (200mV, IHF '66)

S/N (IHF A)
PHONO 70 dB (80dB, IHF '66)
CD,TAPE,DVD,VCR1,TV/DSS/VCR2 75 dB (85dB, IHF '66)

Input impedance
PHONO 47 kΩ
CD,TAPE,DVD,VCR1,TV/DSS/VCR2 22 kΩ

Tone controls
BASS 50 Hz, +10 to -10 dB
TREBLE 20 kHz, +10 to -10 dB

Loudness control (volume at -30 dB) 50 Hz, +9 dB

Subwoofer frequency response 7 - 100 Hz, ±3 dB

FM Tuner Section

Frequency range 87.9 — 107.9 MHz

Sensitivity 11.2 dBf (2μV, IHF '58)

50 dB quieting Sensitivity
MONO 18.3 dBf (4.5μV, IHF '58)
STEREO 38.3 dBf (45μV, IHF '58)

Total harmonic distortion
MONO 0.2%
STEREO 0.3%

S/N
MONO 73 dB
STEREO 67 dB

Frequency response 20 Hz — 15 kHz (+1dB, -2dB)

Alternate channel selectivity 65 dB

Capture ratio 1.5 dB

Image rejection at 98MHz 40 dB

Spurious response rejection at 98MHz 75 dB

AM suppression 50 dB

Stereo separation
1 kHz 40 dB
10kHz 30 dB

Antenna terminal(s) 75Ω (unbalanced)

Technics®

© 1998 Matsushita Electronics (S) Pte. Ltd.
All rights reserved. Unauthorized copying and distribution is a violation of law.

⚠ WARNING

This service information is designed for experienced repair technicians only and is not designed for use by the general public. It does not contain warnings or cautions to advise non-technical individuals of potential dangers in attempting to service a product. Products powered by electricity should be serviced or repaired only by experienced professional technicians. Any attempt to service or repair the product or products dealt with in this service information by anyone else could result in serious injury or death.

■ AM Tuner Section

Frequency range	530 — 1710 kHz
Sensitivity	20 μ V, 330 μ V/m
Selectivity	55 dB
IF rejection at 1000kHz	50 dB

■ Video Section

Output voltage at 1 V input (unbalanced)	1 \pm 0.1 Vp-p
Maximum input voltage	1.5 Vp-p
Input/output impedance	75 Ω

■ General

Power consumption	350 W (In standby condition : 2W)
Power supply	AC 120V, 60 Hz
Dimensions (W x H x D)	430 x 158 x 312 mm (16 ¹⁵ / ₁₆ " x 6 ⁷ / ₃₂ " x 12 ⁹ / ₃₂ ")
Weight	9.8 kg (21.8 lb.)

Notes :

- Specifications are subject to change without notice.
Weight and dimensions are approximate.
- Total harmonic distortion is measured by the digital spectrum analyzer.

■ Contents

	PAGE
• BLOCK DIAGRAM	3 ~ 7
• SCHEMATIC DIAGRAM	8 ~ 23
• PRINTED CIRCUIT BOARD	24 ~ 30
• WIRING DIAGRAM	31
• CABINET PARTS LOCATION	32
• REPLACEMENT PARTS LIST	33 ~ 35
• RESISTORS & CAPACITORS	36 ~ 40
• PACKAGING	40

Block Diagram

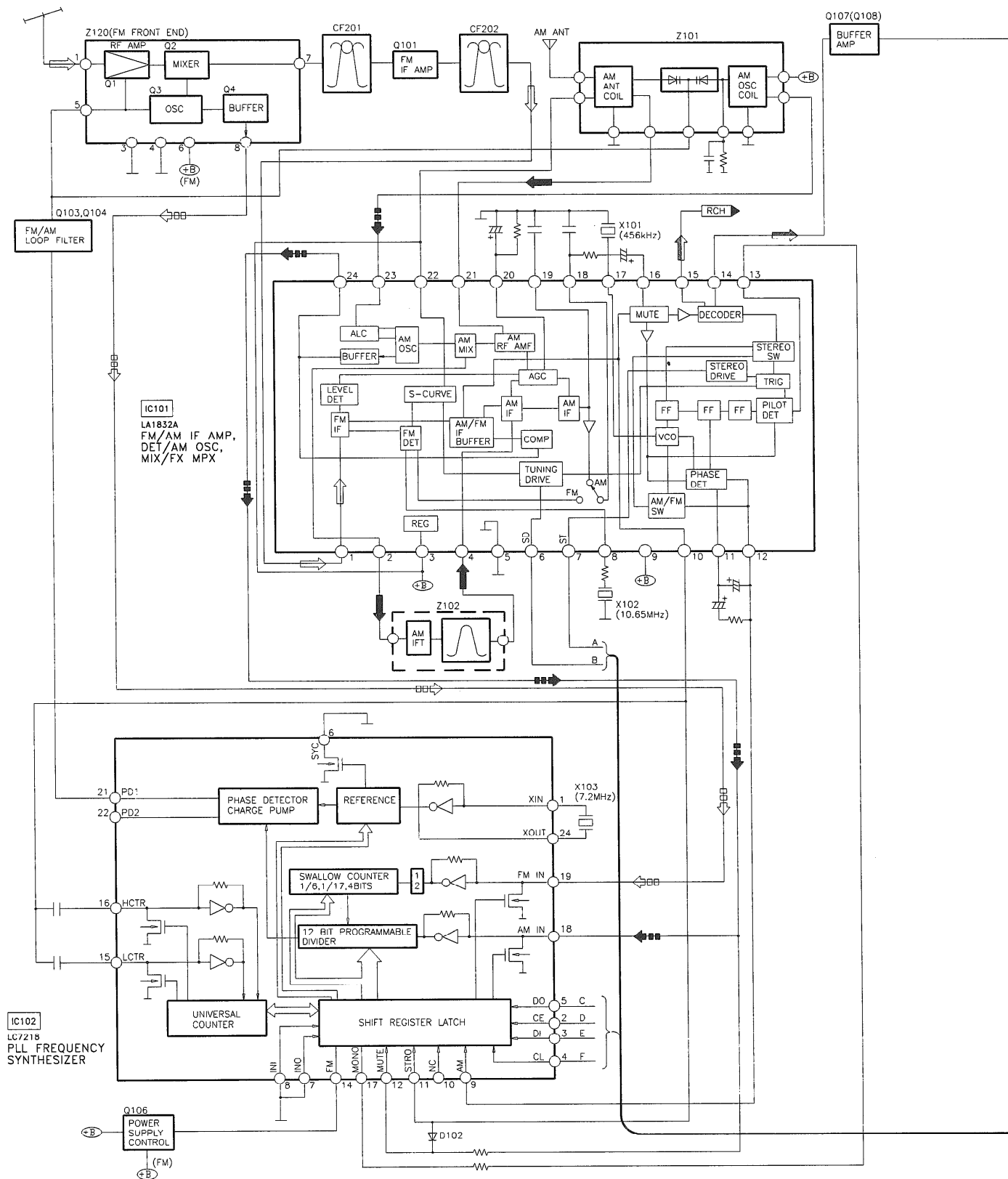

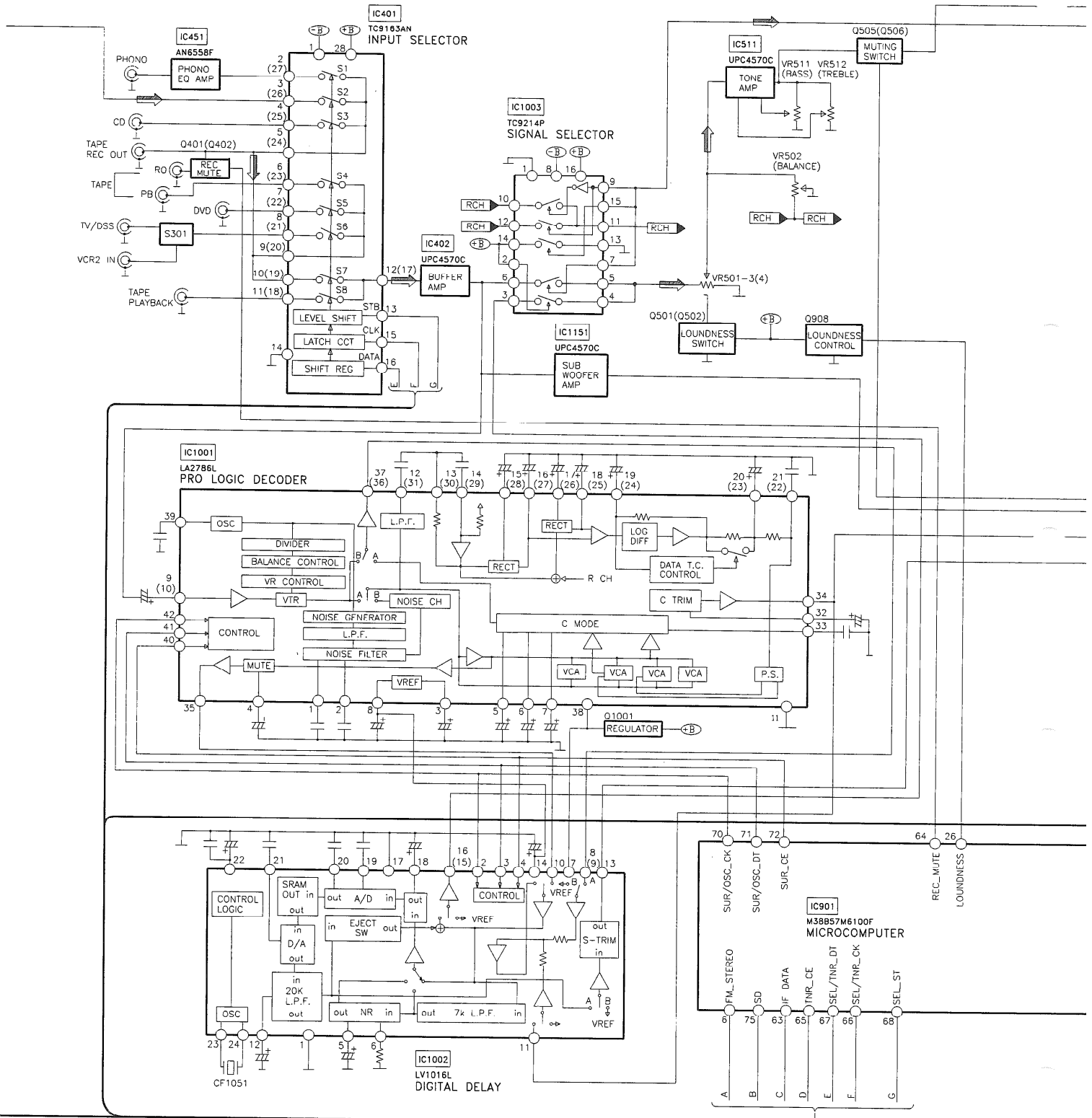

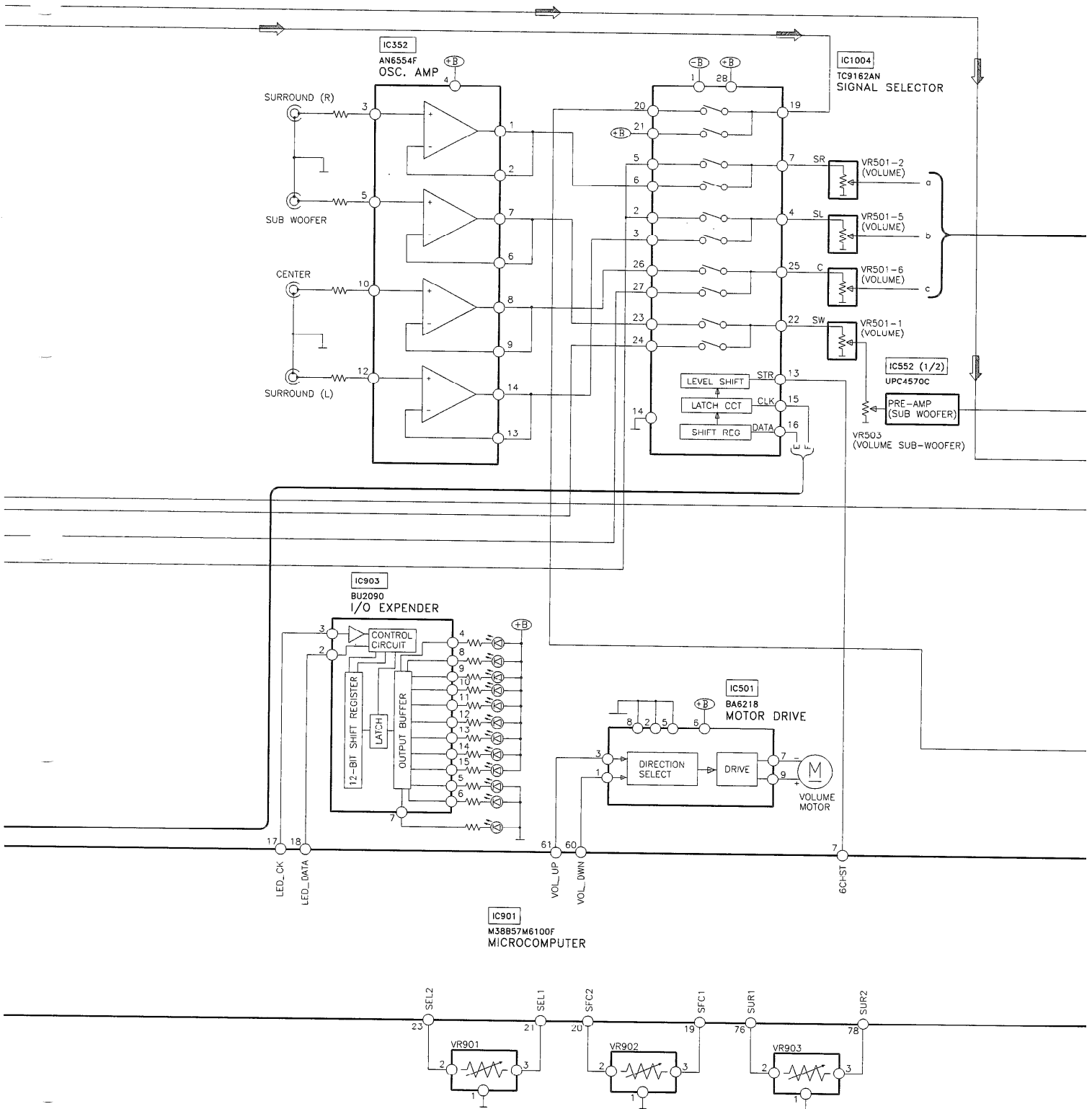

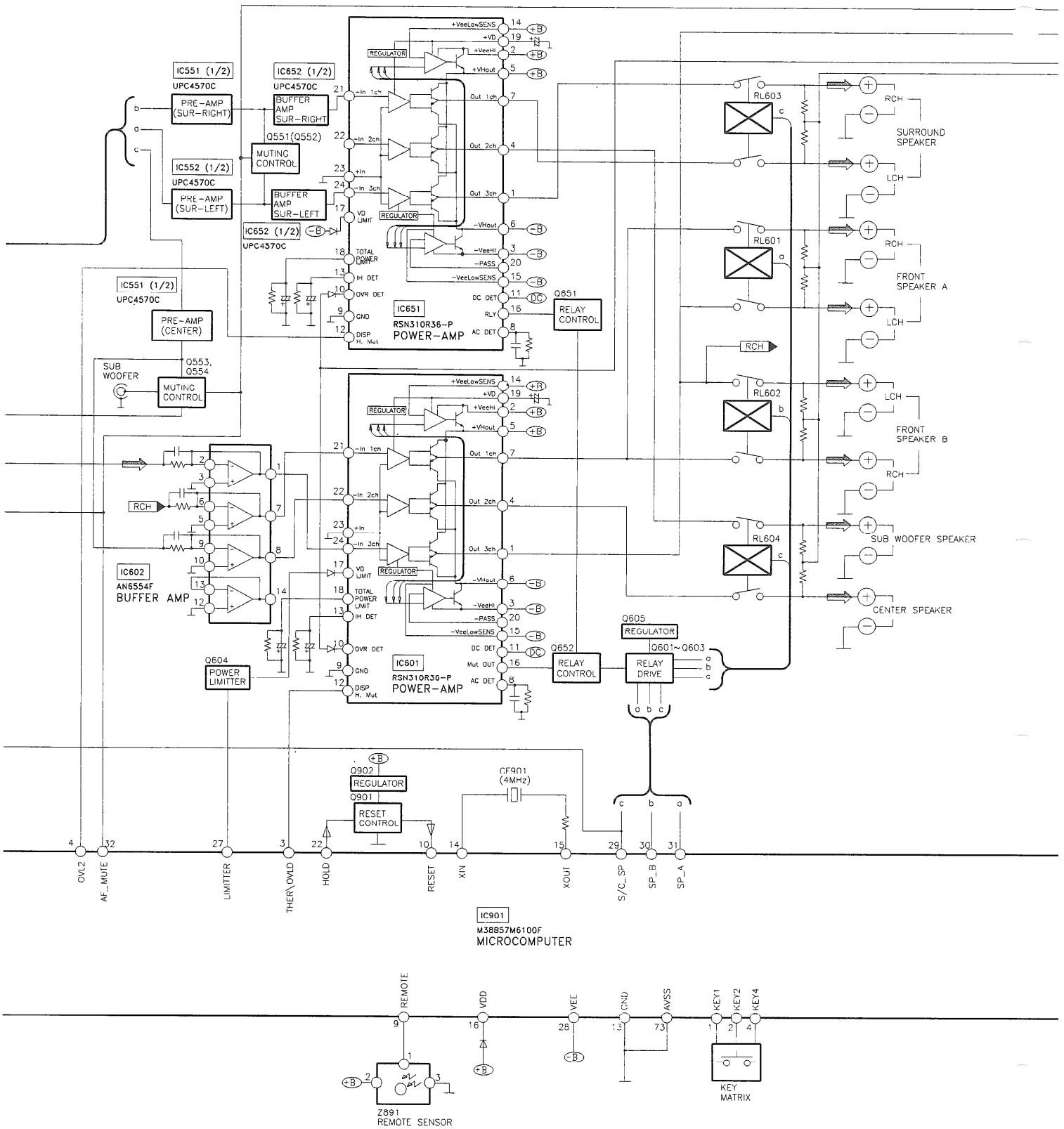

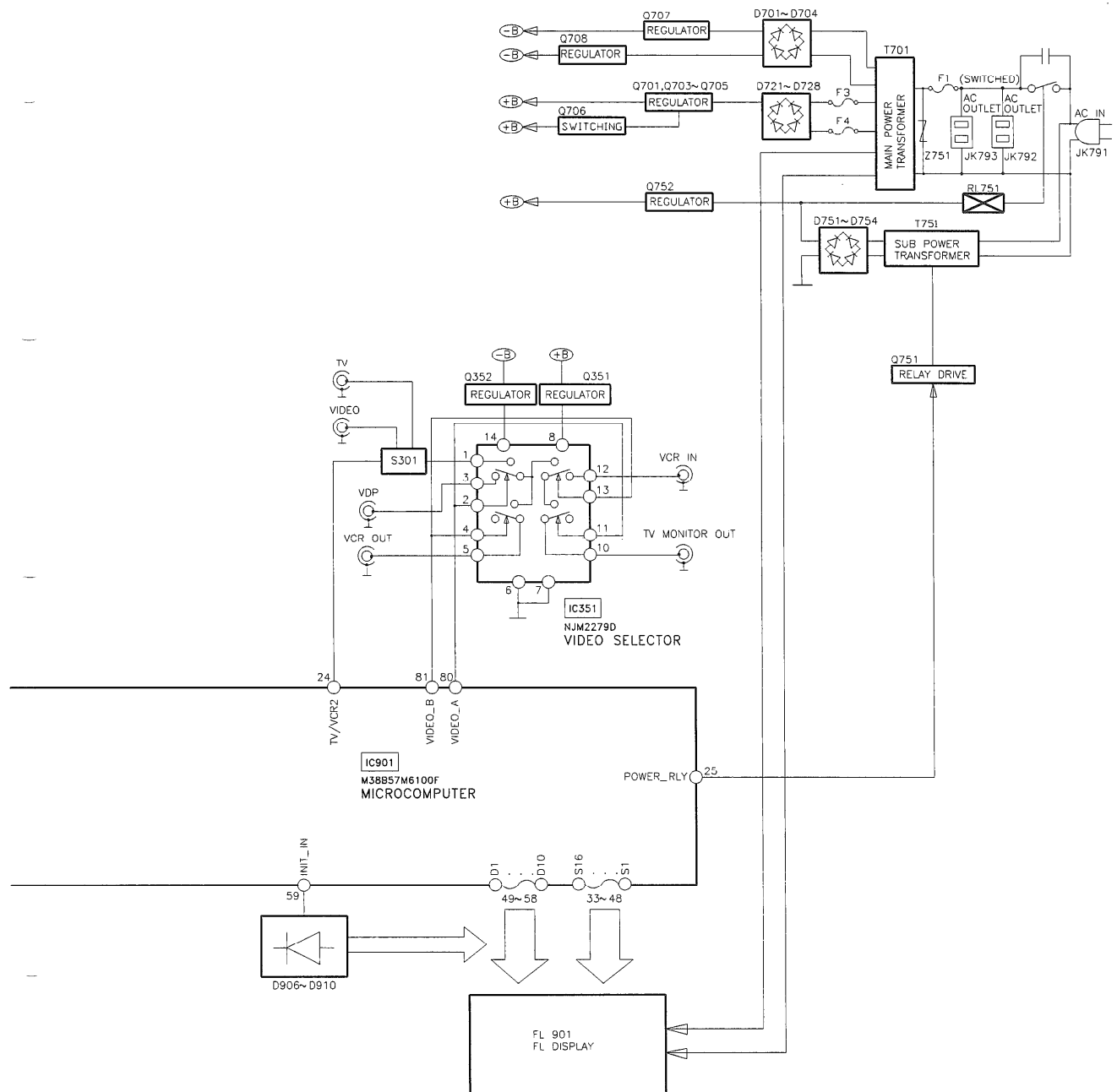
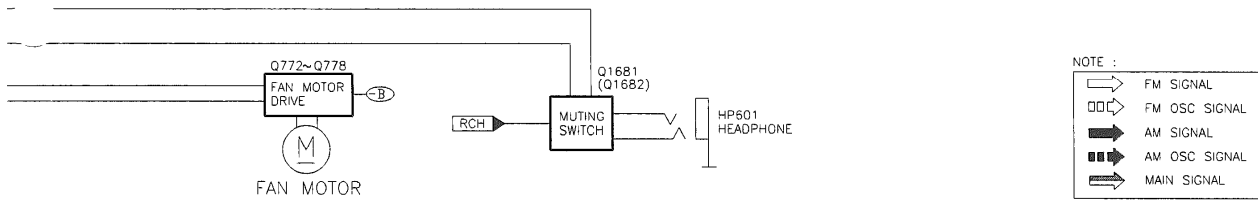

■ Schematic Diagram

Note : (All schematic diagrams may be modified at any time with the development of new technology)

- | | | | | | |
|--------|---|---------------------------|---------|---|-----------------------------|
| • S301 | : | VCR2/TV/DSS select | • VR501 | : | Volume control |
| • S946 | : | Power switch | • VR502 | : | Balance control |
| • S948 | : | Muting switch | • VR503 | : | Subwoofer level control |
| • S950 | : | FM Mode switch | • VR511 | : | Bass control |
| • S951 | : | Band select switch | • VR512 | : | Treble control |
| • S952 | : | Tuning decrease switch | • VR901 | : | Input Selector knob |
| • S953 | : | Tuning increase switch | • VR902 | : | Dolby Pro-Logic select knob |
| • S955 | : | Memory switch | • VR903 | : | Mode /SFC on off knob |
| • S956 | : | T. Mode switch | | | |
| • S958 | : | Help-Reset switch | | | |
| • S976 | : | DVD 6CH switch | | | |
| • S980 | : | Speakers A switch | | | |
| • S981 | : | Speakers B switch | | | |
| • S982 | : | Loudness select switch | | | |
| • S985 | : | Center mode select switch | | | |
| • S986 | : | Delay switch | | | |

• Signal line

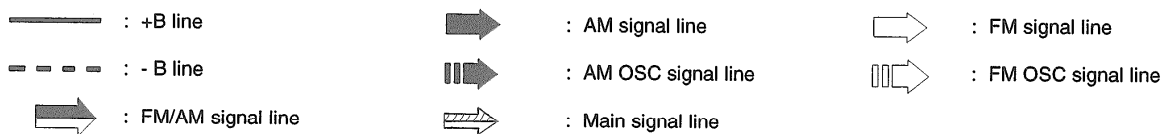

- The voltage value and waveforms are the reference voltage of this unit measured by DC electronic voltmeter (high impedance) and oscilloscope on the basis of chassis. Accordingly, there may arise some error in voltage values and waveforms depending upon the internal impedance of the tester or the measuring unit.

< > FM

• Importance safety notice:

Components identified by  mark have special characteristics important for safety. Furthermore, special parts which have purposes of fire-retardant (resistors), high-quality sound (capacitors), low-noise (resistors), etc. are used. When replacing any of components, be sure to use only manufacturer's specified parts shown in the parts list.

Caution !

IC, LSI and VLSI are sensitive to static electricity.

Secondary trouble can be prevented by taking care during repair.

- Cover the parts boxes made of plastics with aluminium-foil.
- Ground the soldering iron.
- Do not touch the pins of IC, LSI or VLSI with fingers directly.
- Put a conductive mat on the work table.

CAUTION : FOR CONTINUED PROTECTION AGAINST FIRE HAZARD, REPLACE ONLY WITH SAME TYPE F1, F3 & F4 - 8A 125V FUSE.



RISK OF FIRE-REPLACE FUSE AS MARKED.

FUSE CAUTION



These symbols located near the fuse indicates that the fuse used is a fast operating type. For continued protection against fire hazard, replace with the same type fuse. For fuse rating, refer to the marking adjacent to the symbol.



Ce symbole indique que le fusible utilisé est à rapide. Pour une protection permanente, n' utiliser que des fusibles de même type. Ce dernier est indiqué là où le présent symbole est apposé.

A MAIN CIRCUIT

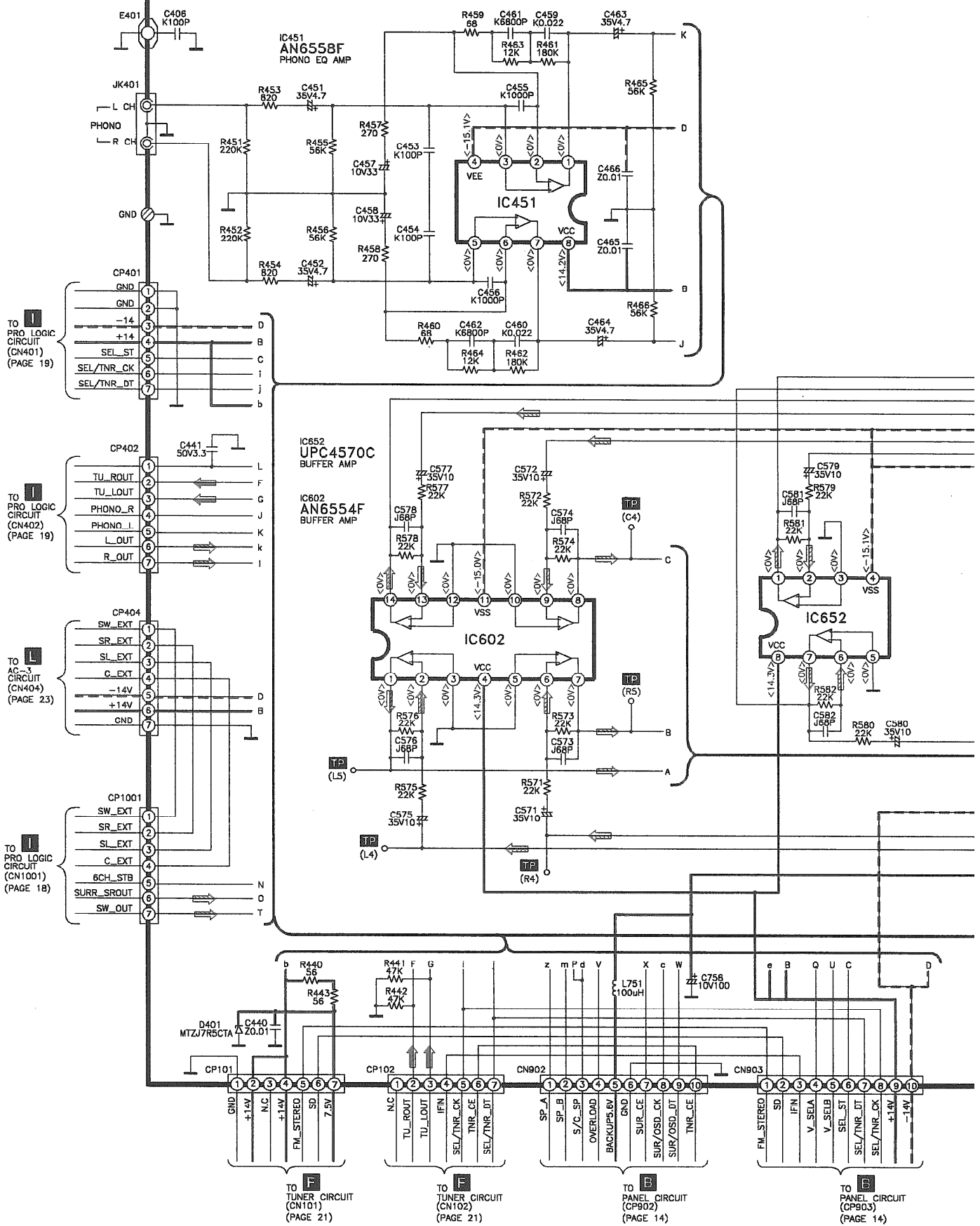

TO **F** TUNER CIRCUIT (CN101) (PAGE 21)

TO **F** TUNER CIRCUIT (CN102) (PAGE 21)

TO **B** PANEL CIRCUIT (CP902) (PAGE 14)

TO **B** PANEL CIRCUIT (CP903) (PAGE 14)

IC651
RSN310R36-P
POWER-AMP

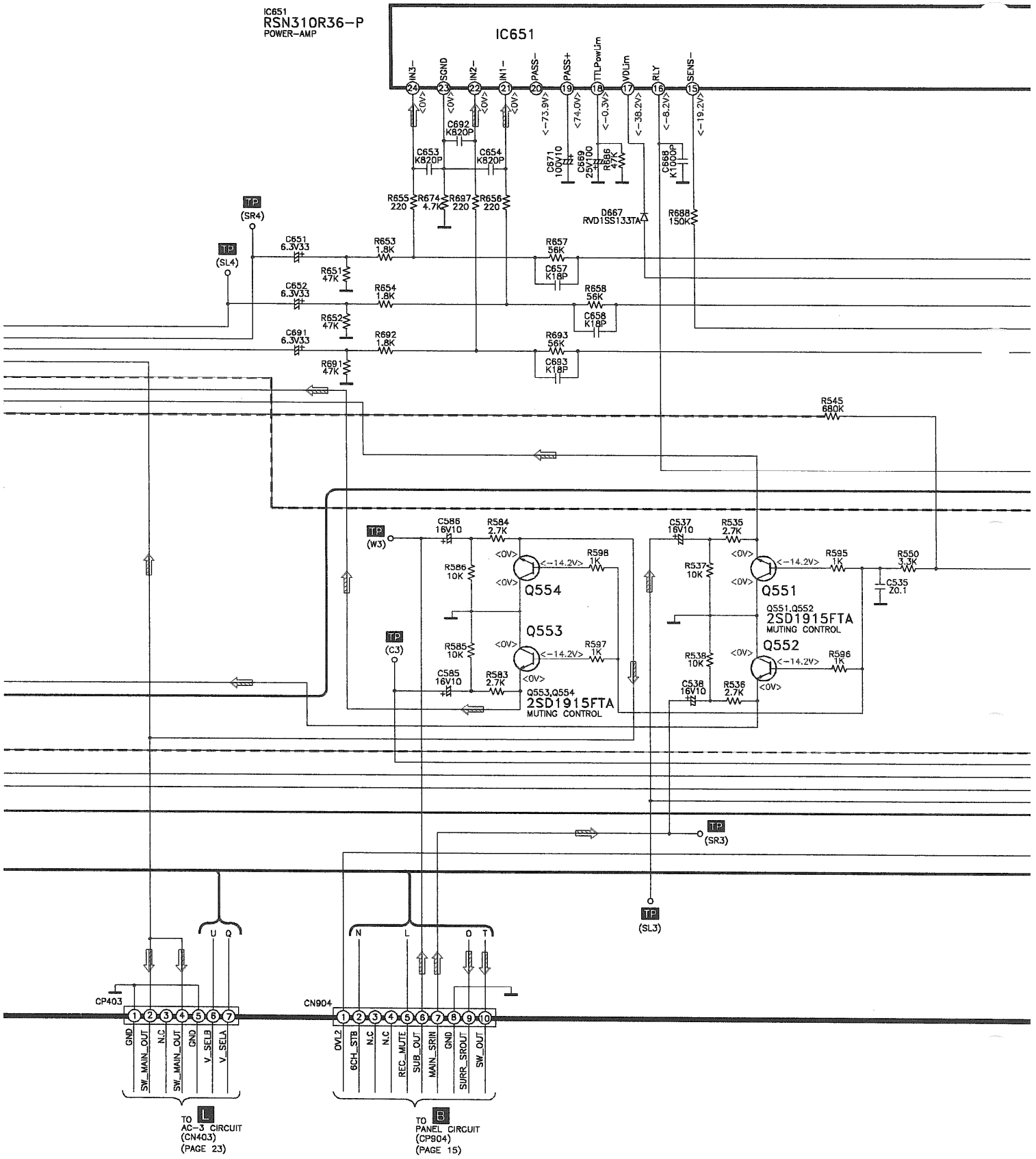

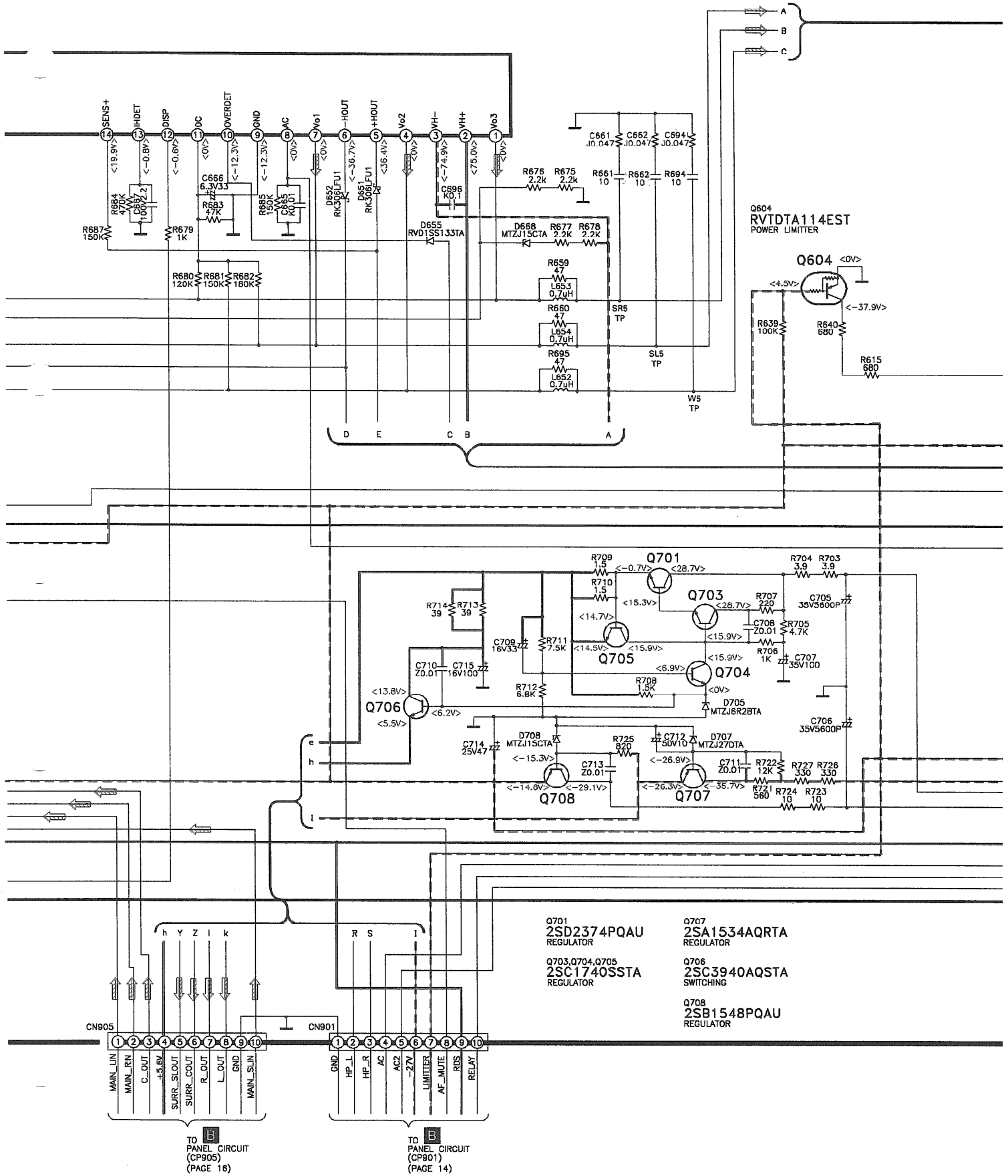

IC601
RSN310R36-P
POWER-AMP

IC601

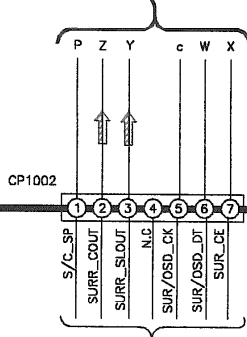
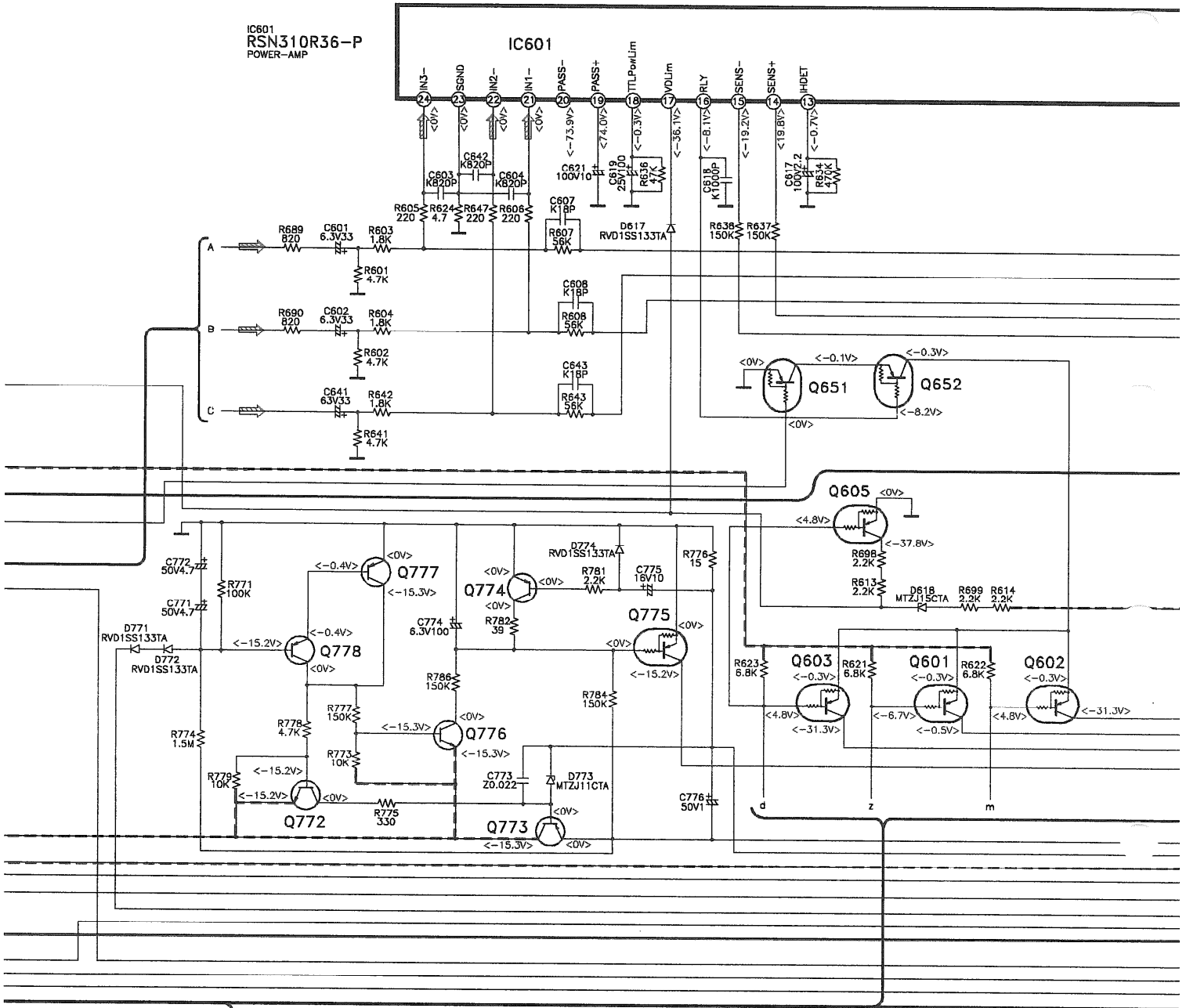

- Q601, Q602, Q603 RVTDTA143XST RELAY DRIVE
- Q651, Q652 RVTDTA143XST RELAY CONTROL
- Q774, Q777, Q778 2SA933SSTA FAN MOTOR DRIVE
- Q772, Q776 2SC174QSSTA FAN MOTOR DRIVE
- Q775 RVTDTA114EST FAN MOTOR DRIVE
- Q773 2SB621AQSTA FAN MOTOR DRIVE
- Q605 RVTDTA114EST REGULATOR

TO PRO LOGIC CIRCUIT (CN1002) (PAGE 18)

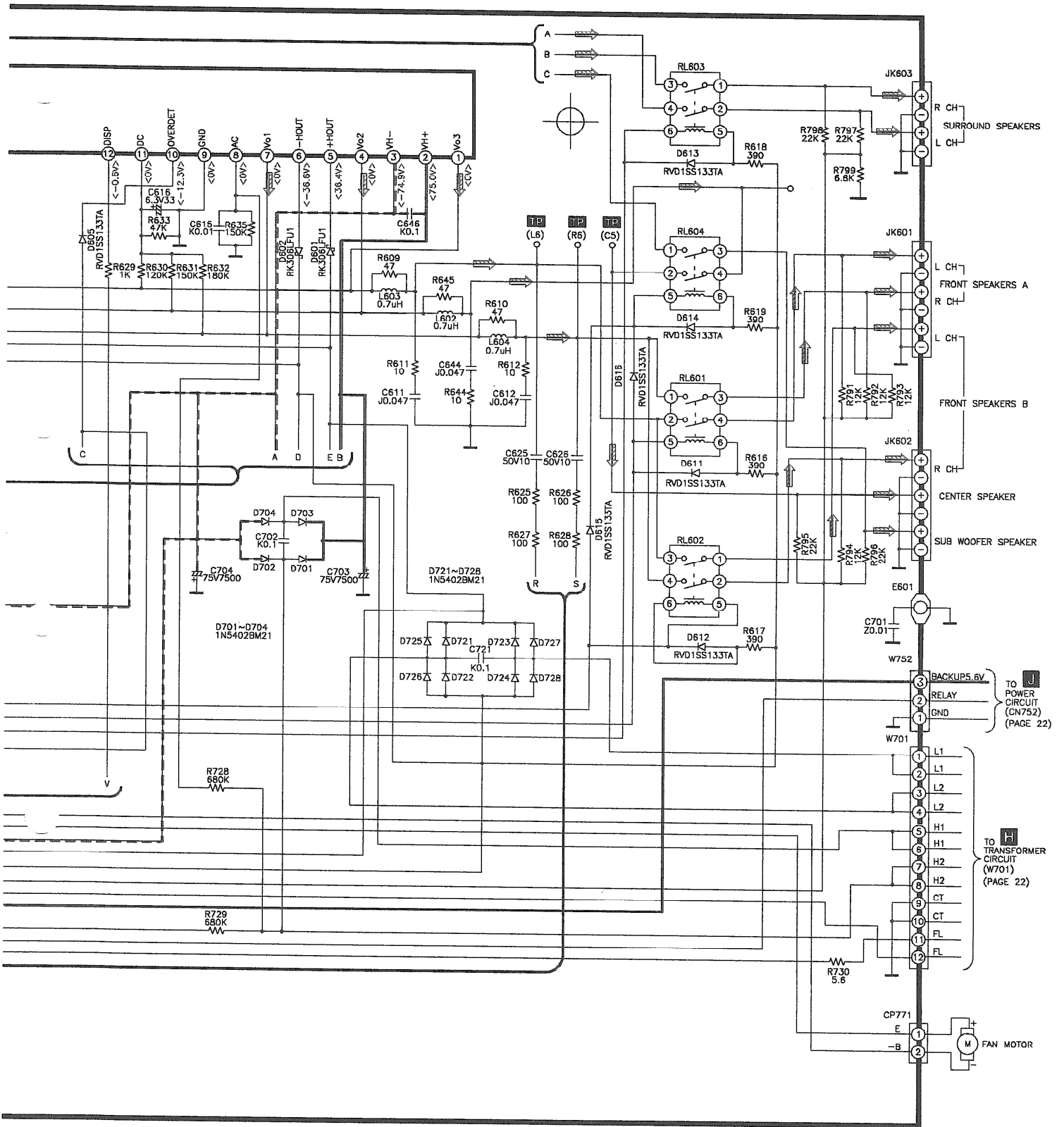

B PANEL CIRCUIT

TO MAIN CIRCUIT (CN901) (PAGE 11)

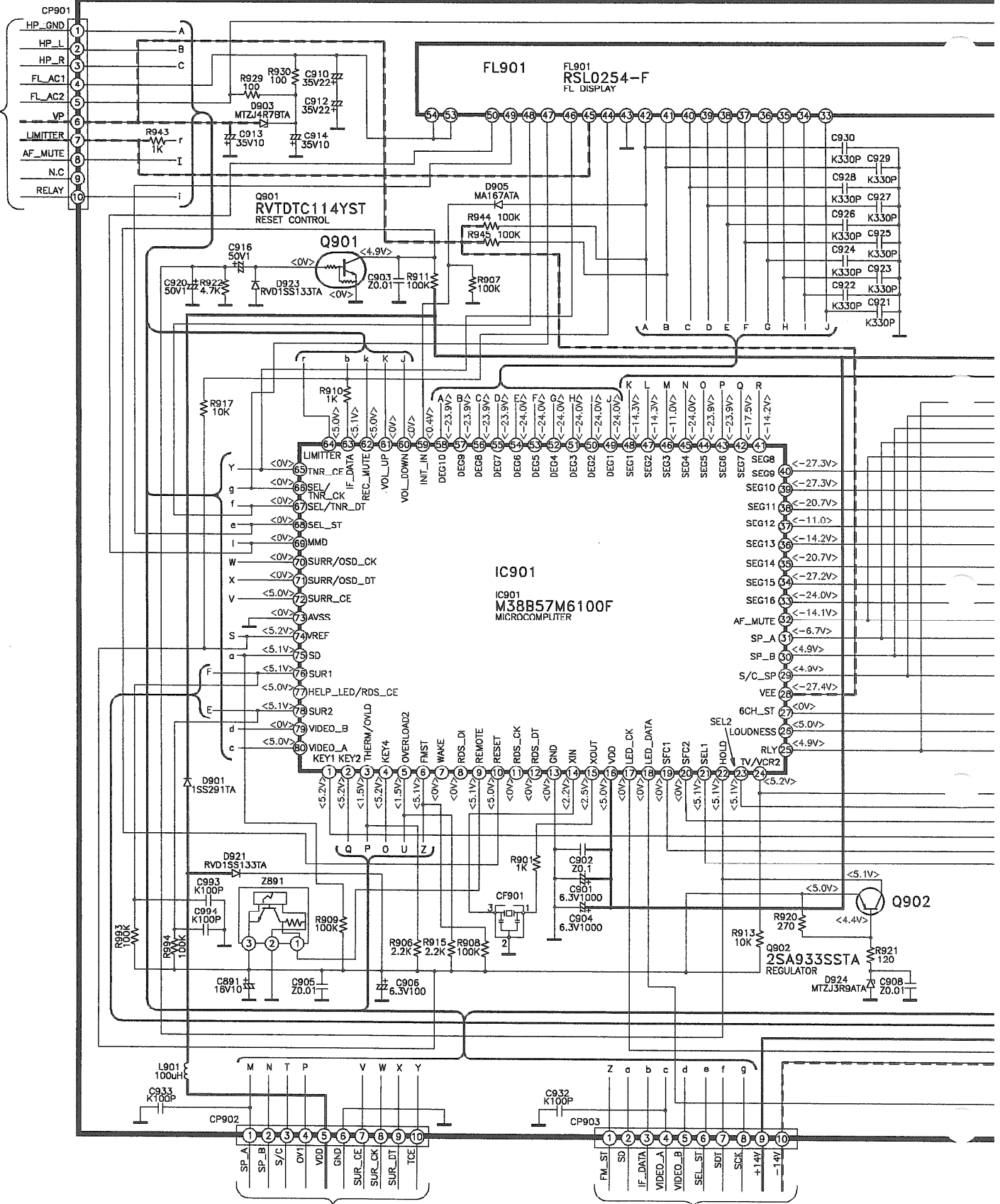

TO MAIN CIRCUIT (CN902) (PAGE 9)

TO MAIN CIRCUIT (CN903) (PAGE 9)

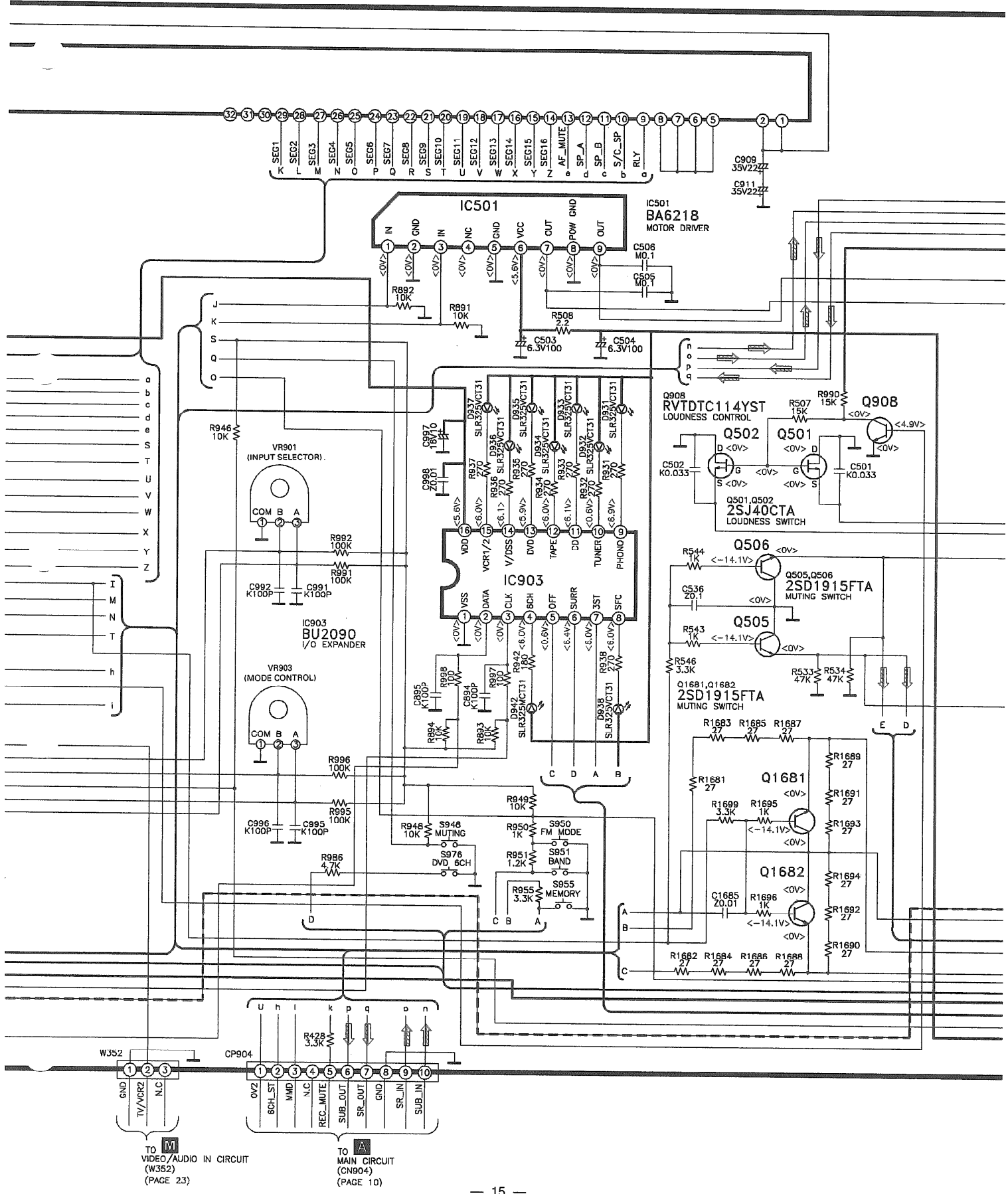

TO VIDEO/AUDIO IN CIRCUIT (W352) (PAGE 23)

TO MAIN CIRCUIT (CP904) (PAGE 10)

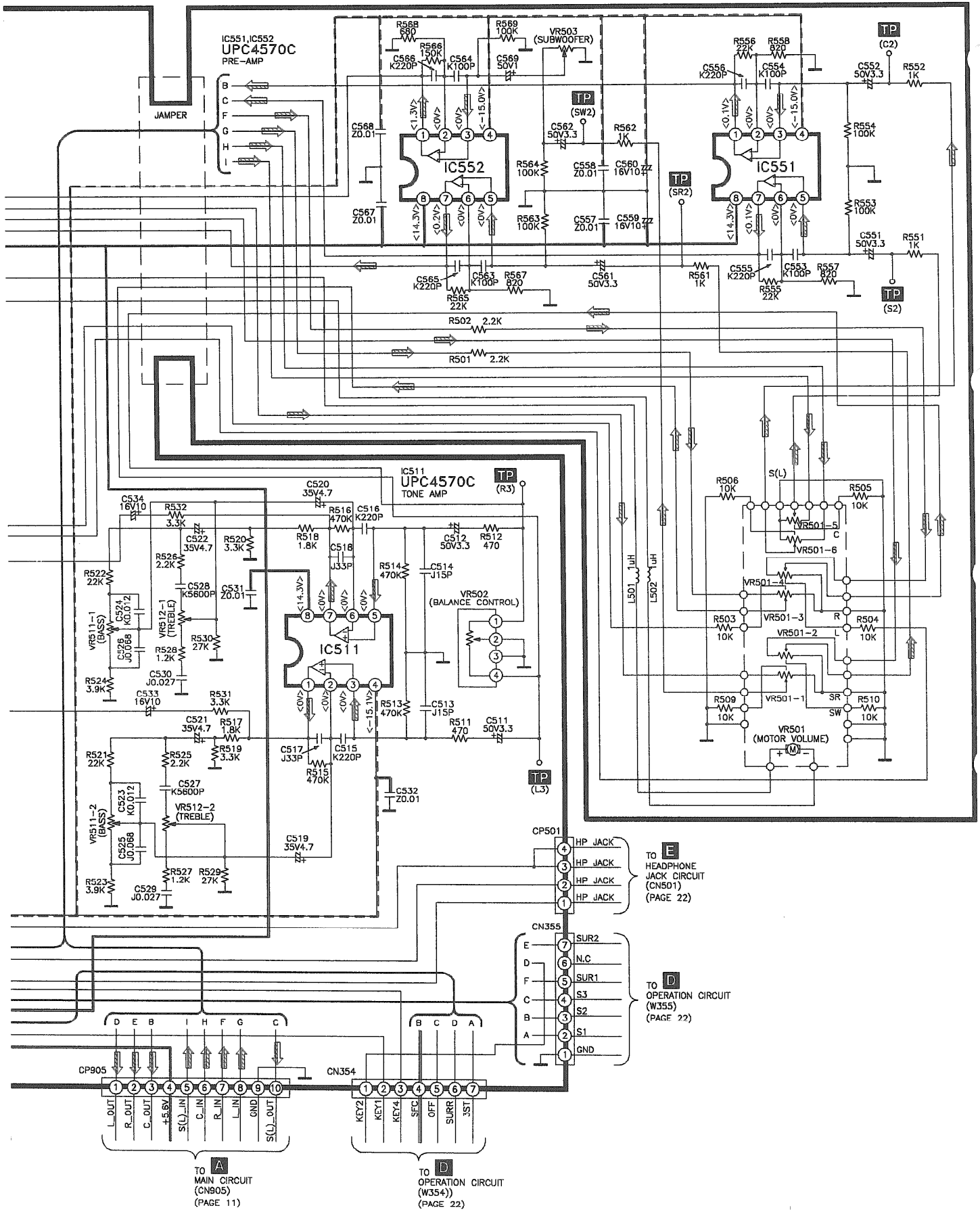

PRO LOGIC CIRCUIT

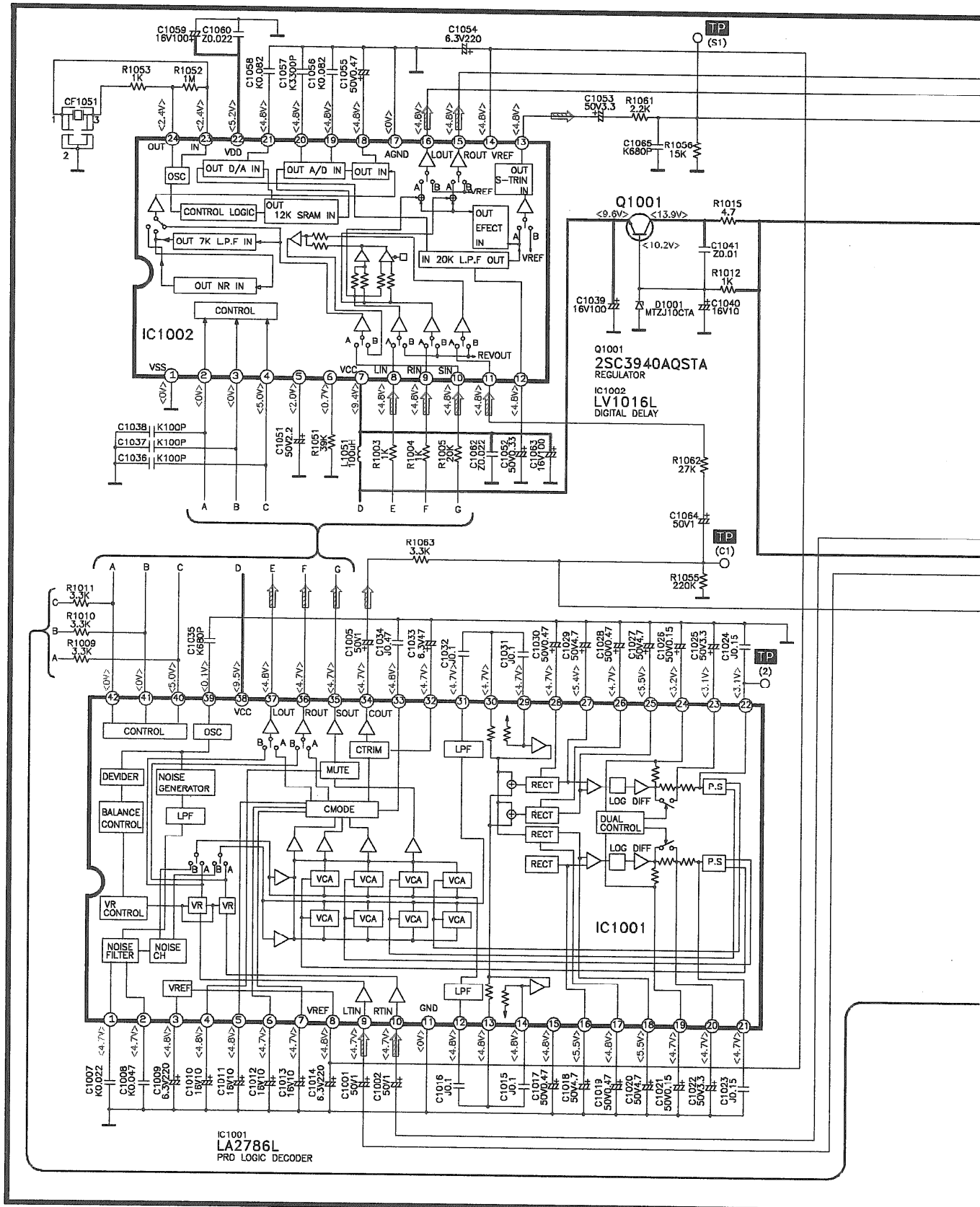

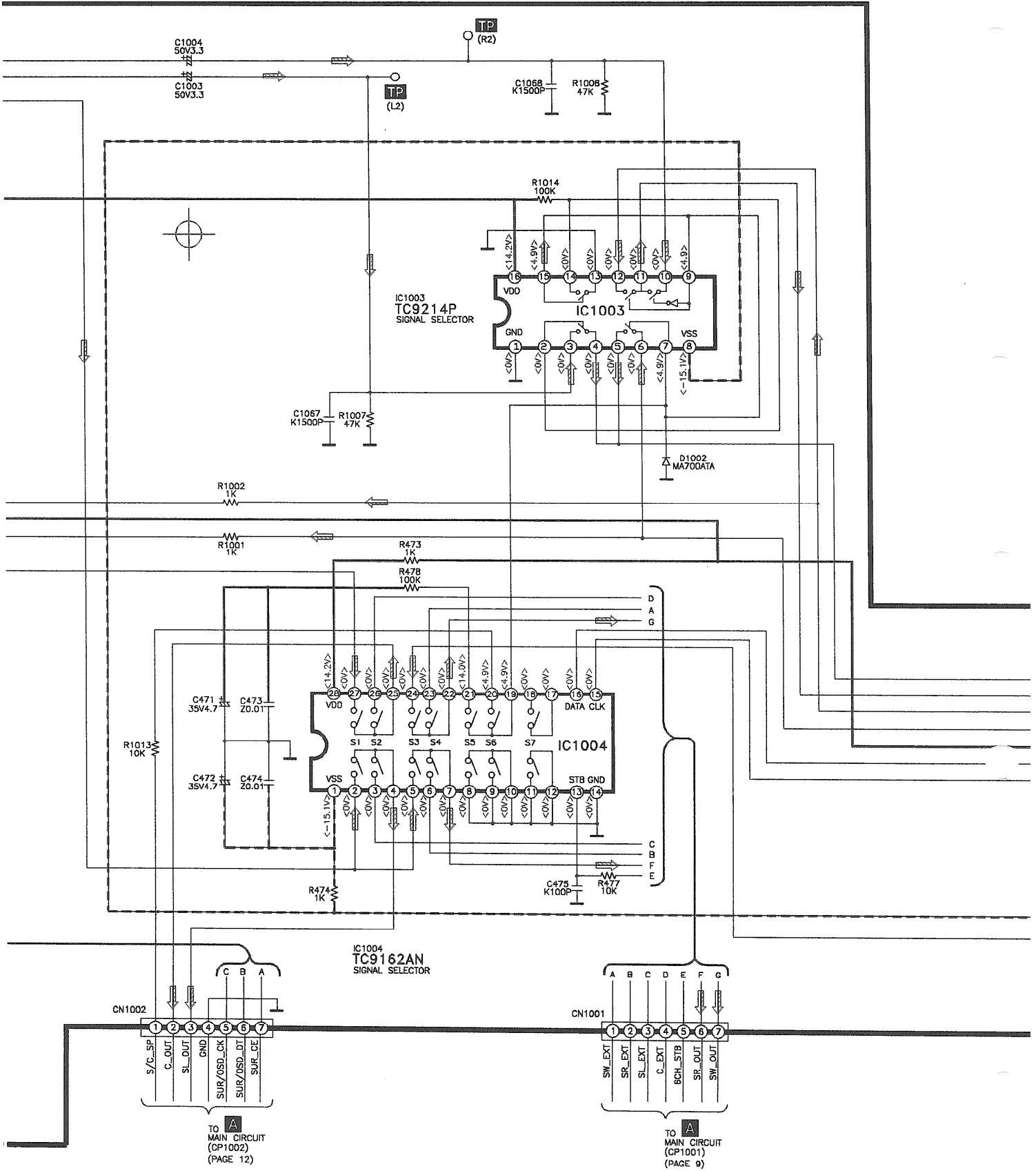

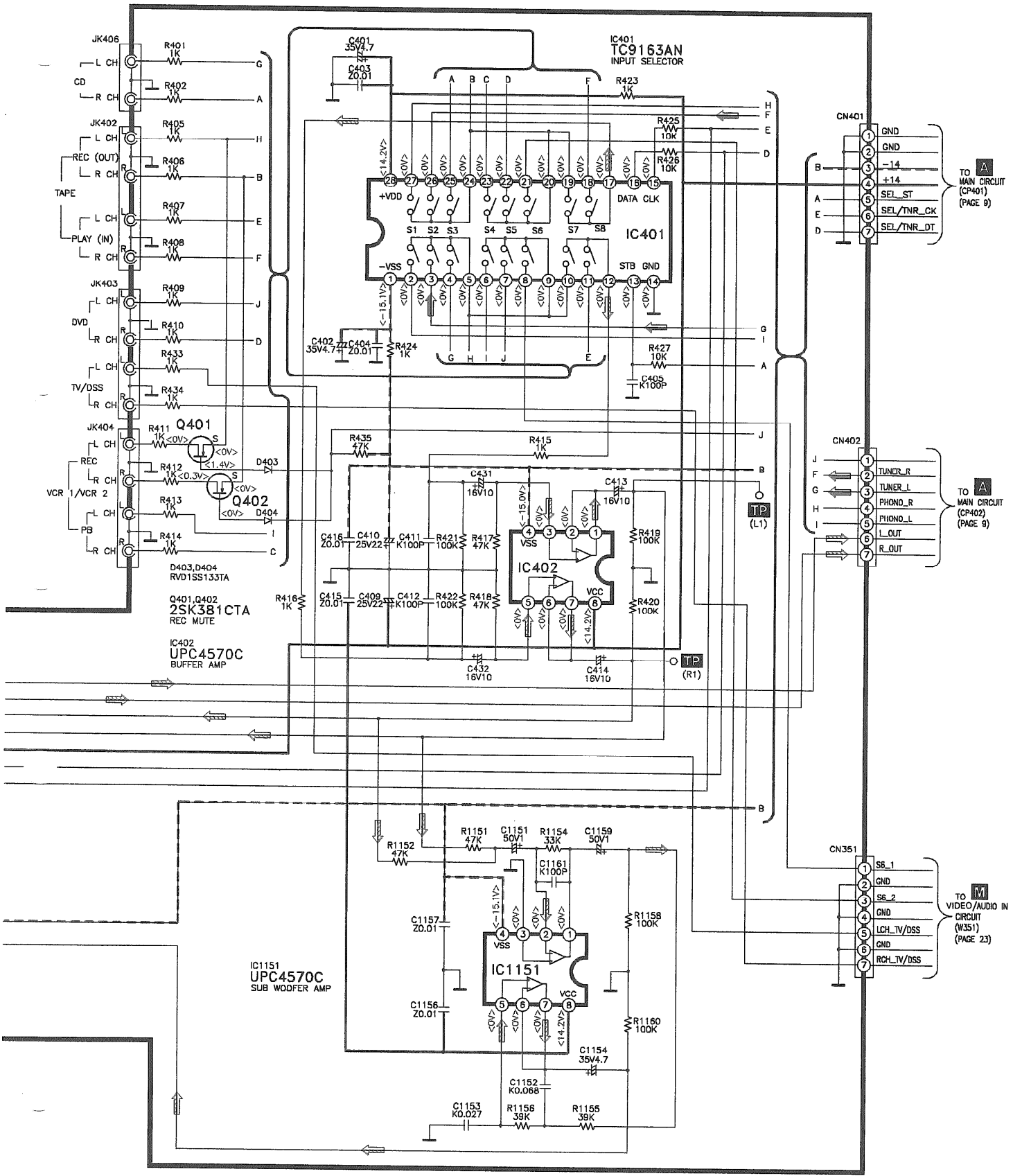

G TUNER PACK CIRCUIT

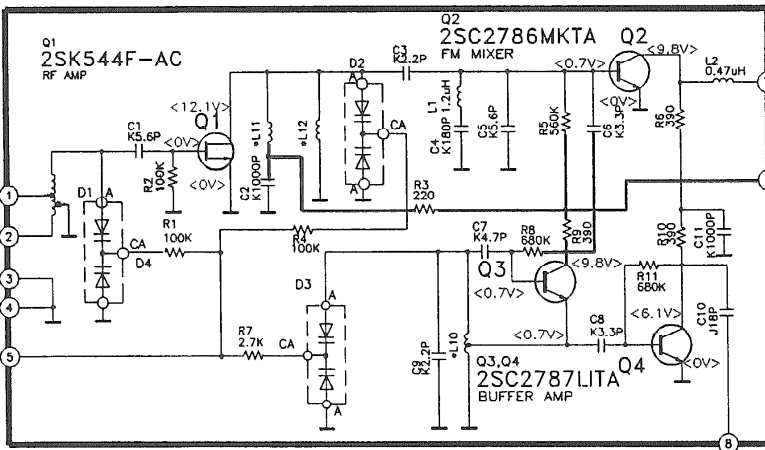

F TUNER CIRCUIT

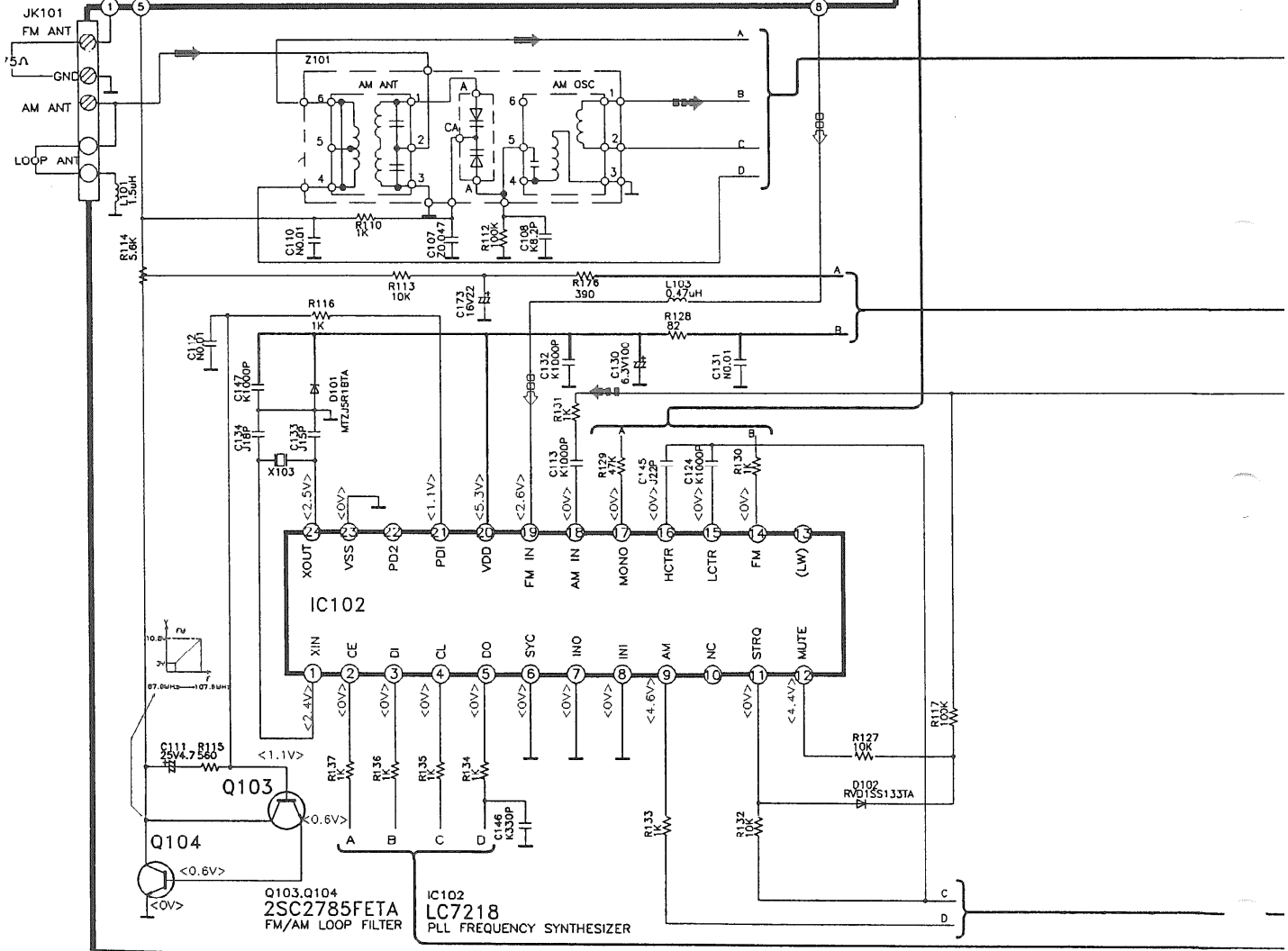

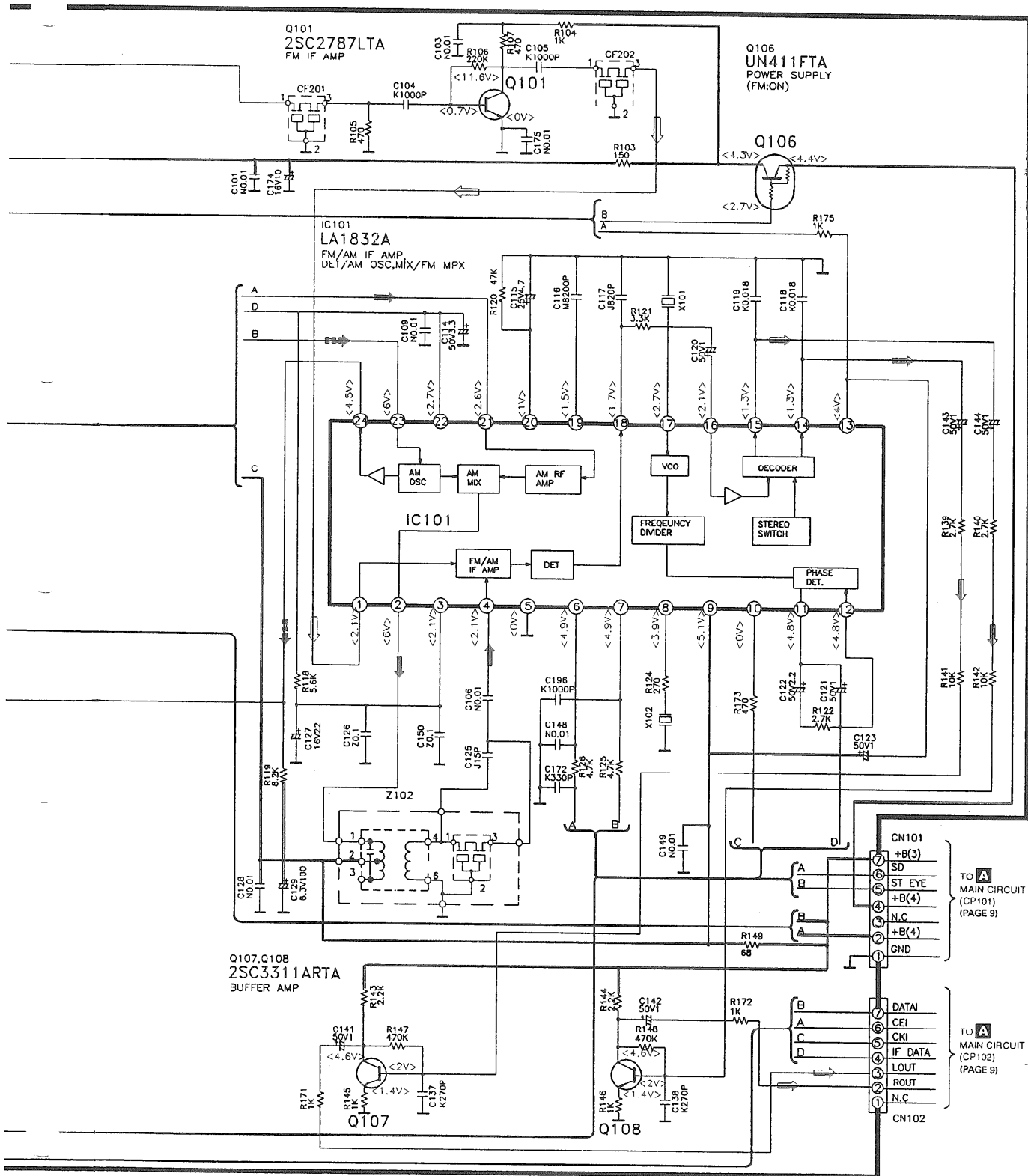

J POWER CIRCUIT

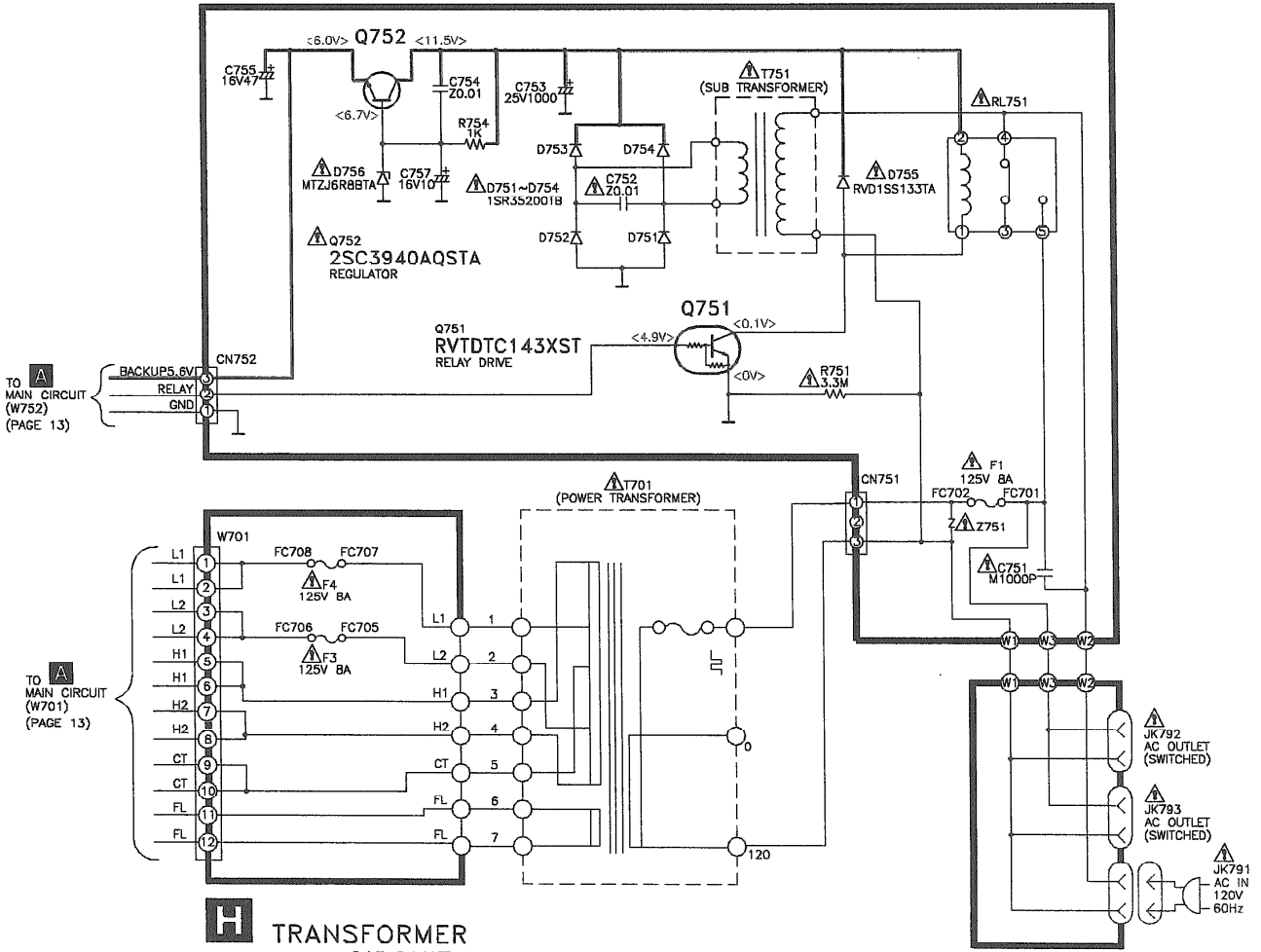

H TRANSFORMER CIRCUIT

D OPERATION CIRCUIT

C AC IN/OUT CIRCUIT

E HEADPHONE JACK CIRCUIT

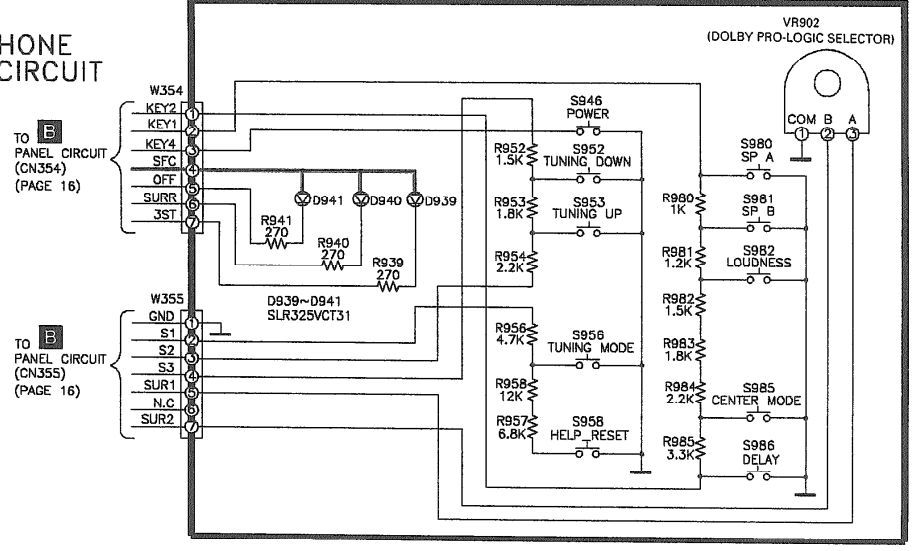
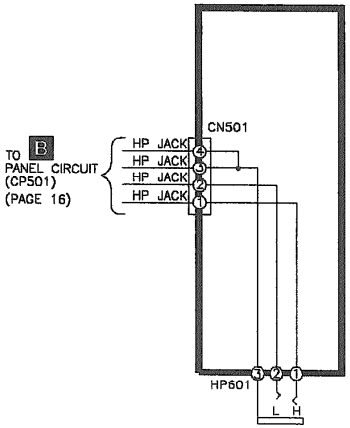

L AC-3 CIRCUIT

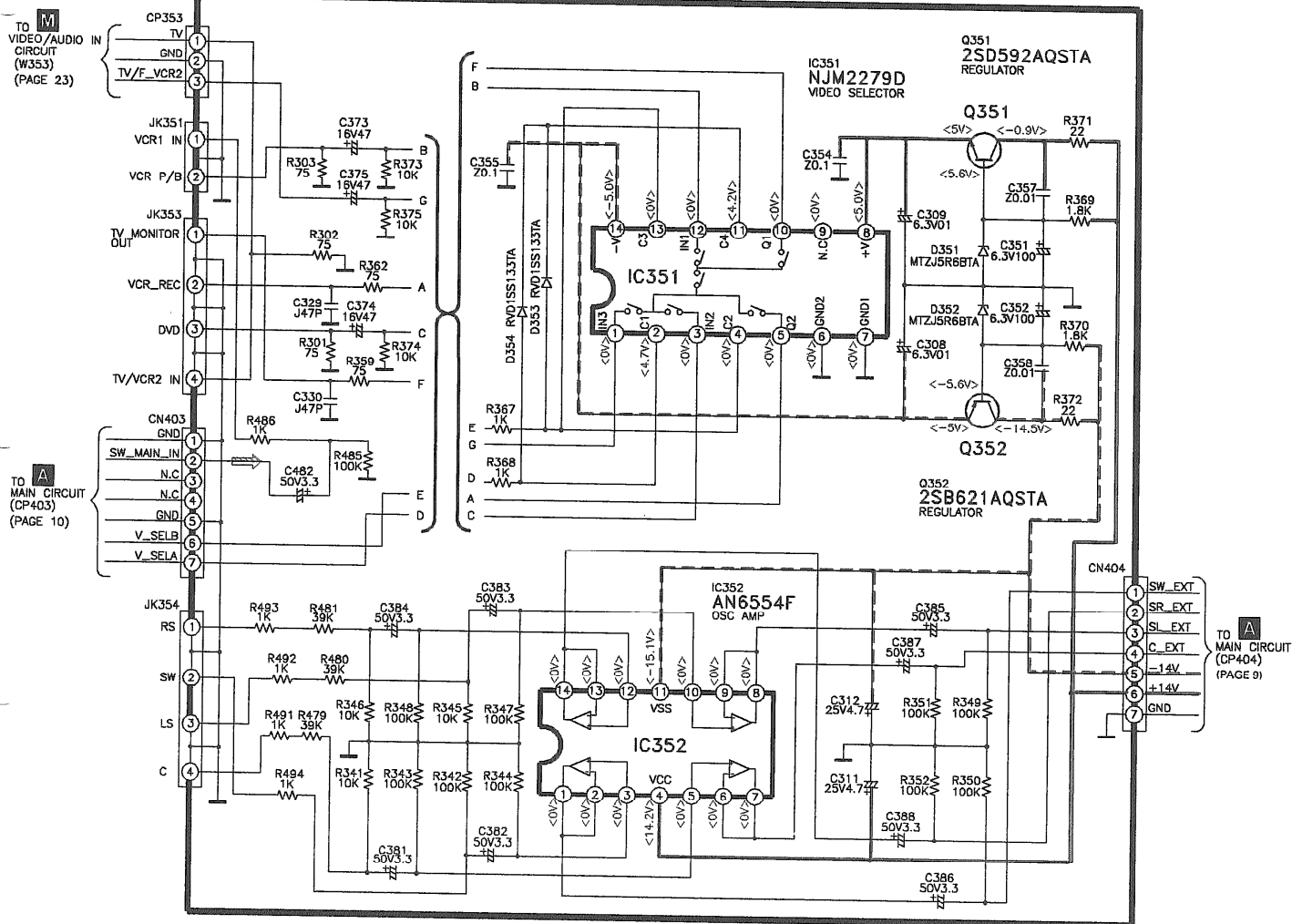

M VIDEO/AUDIO IN CIRCUIT

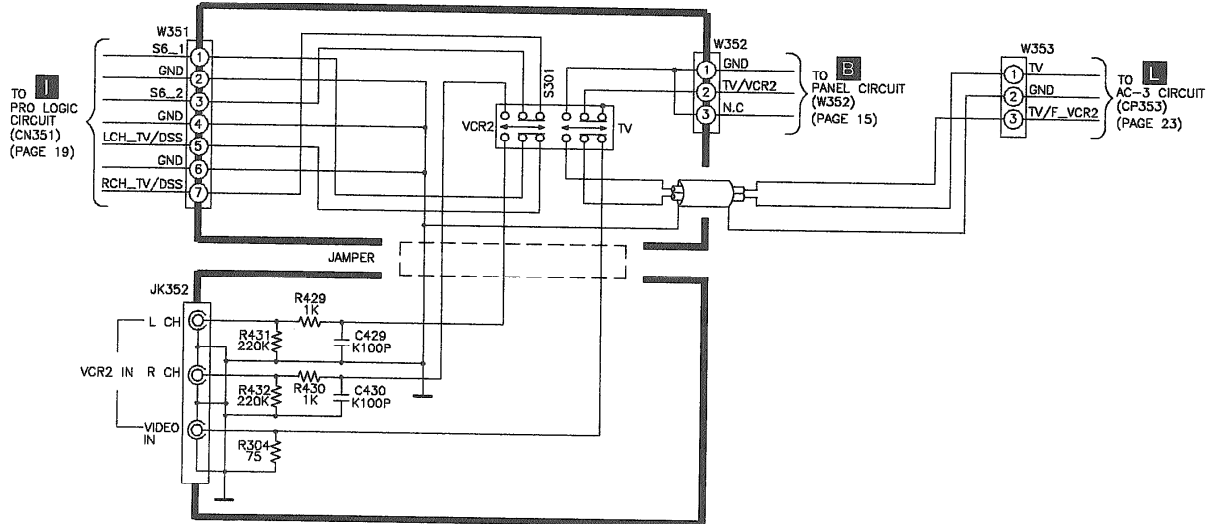

Printed Circuit Board

B PANEL P.C.B. (REP2628B-S)

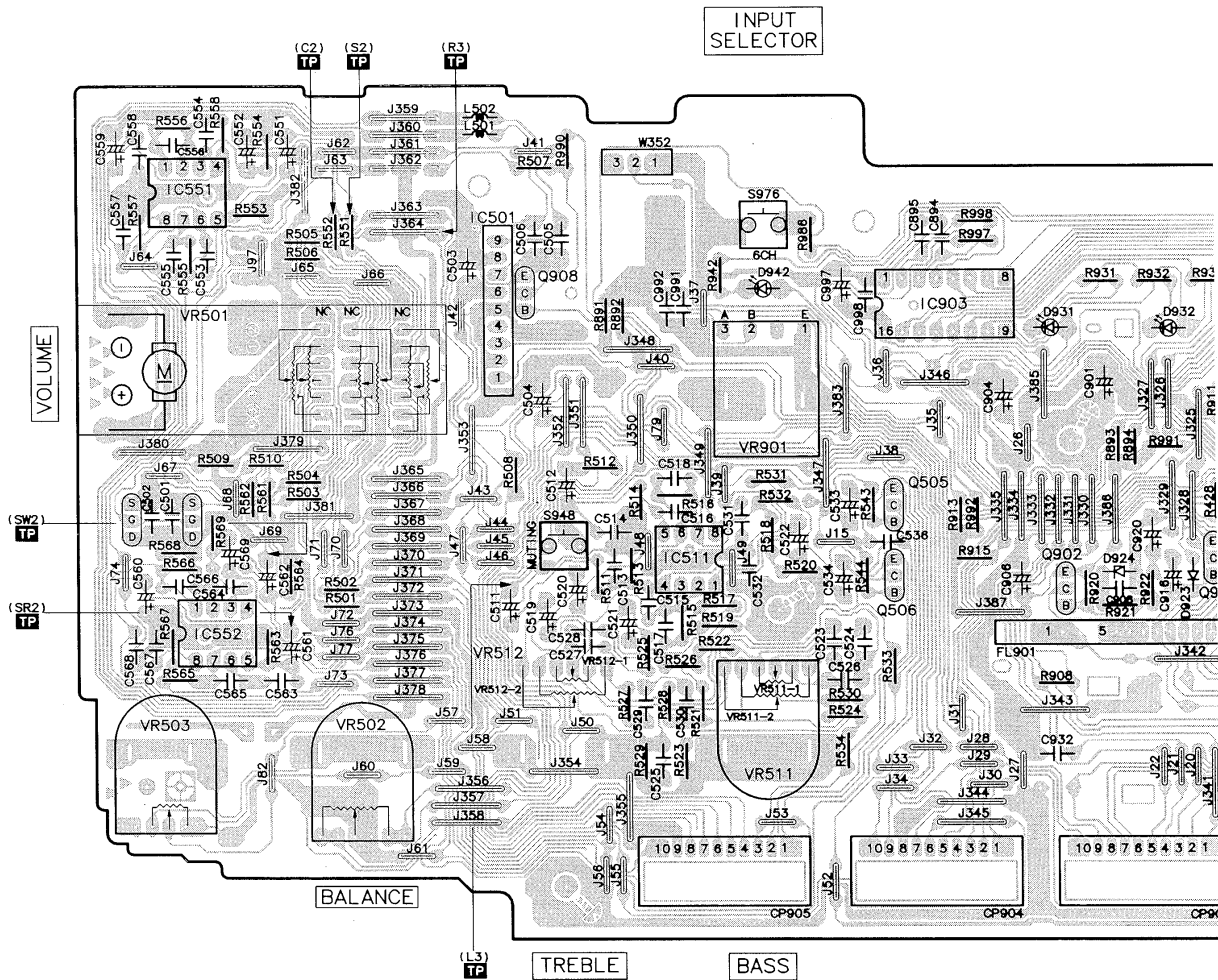

E HEADPHONE JACK P.C.B. (REP2628B-S)

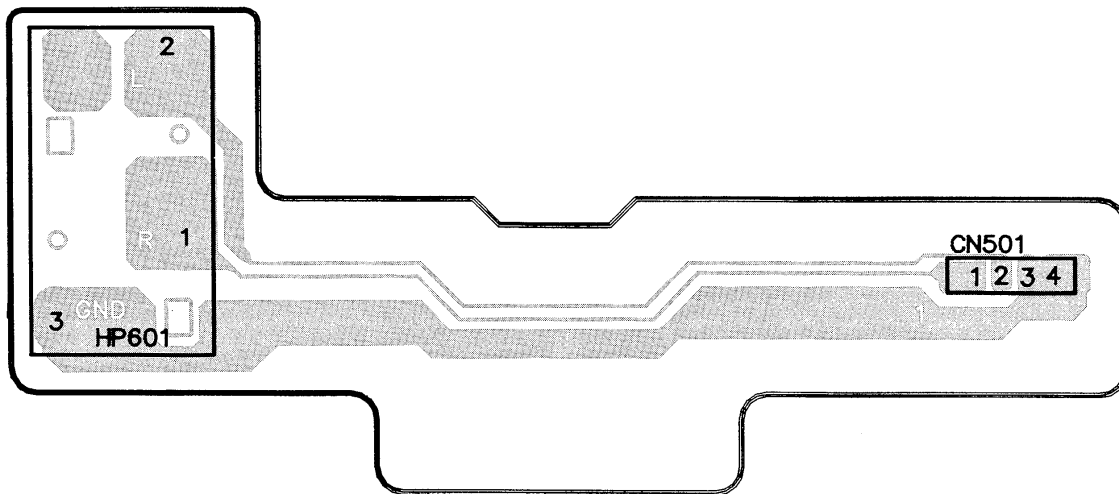

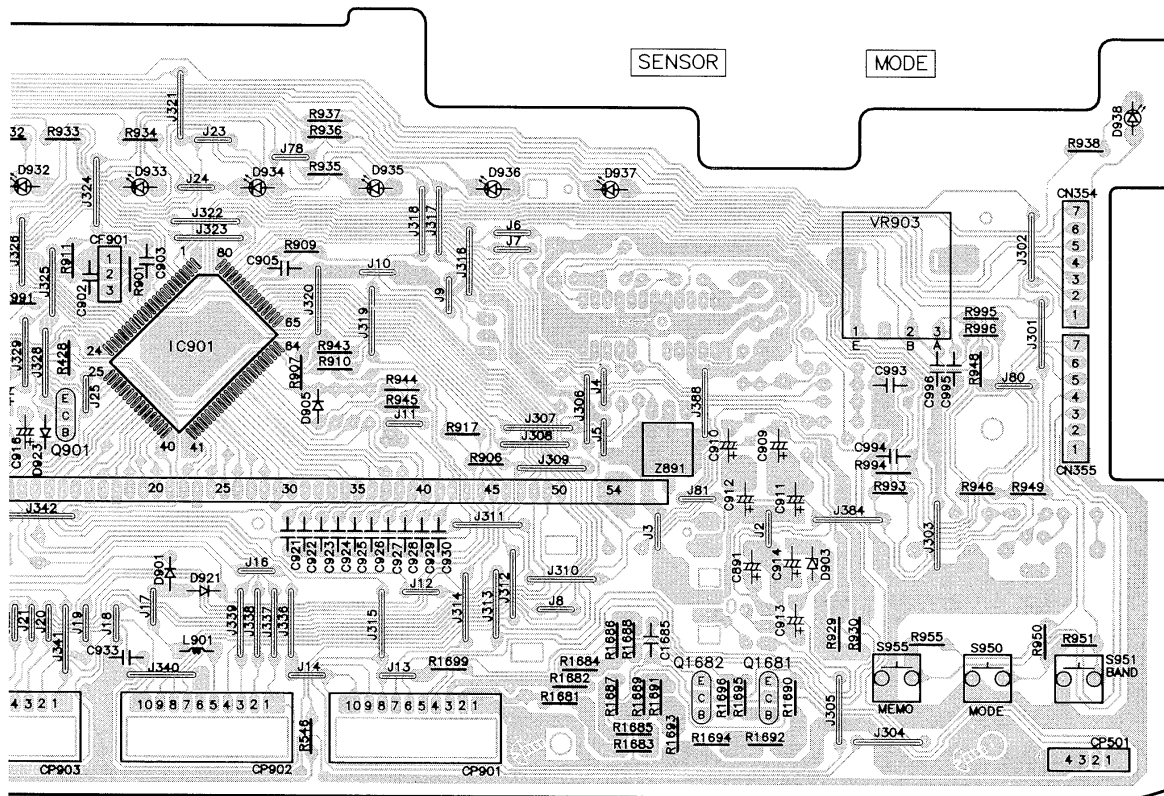

D OPERATION P.C.B. (REP2628B-S)

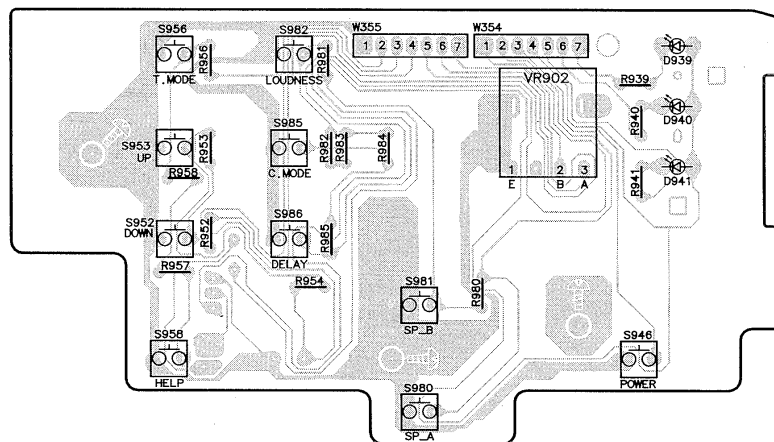

I PRO LOGIC P.C.B. (REP2629C-P)... P (REP2629D-P)... PC

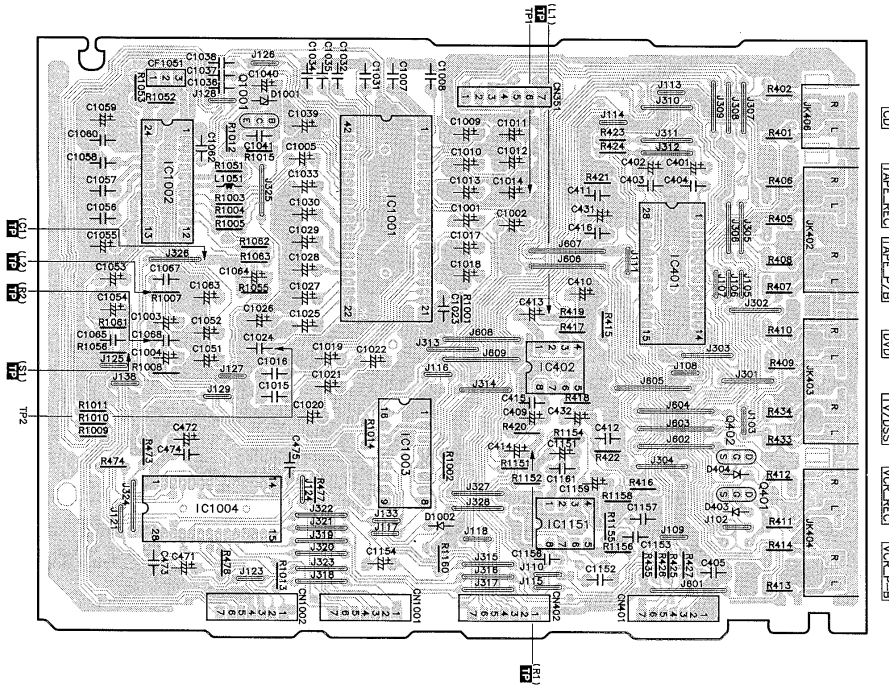

L AC-3 P.C.B. (REP2629C-P)... P (REP2629D-P)... PC

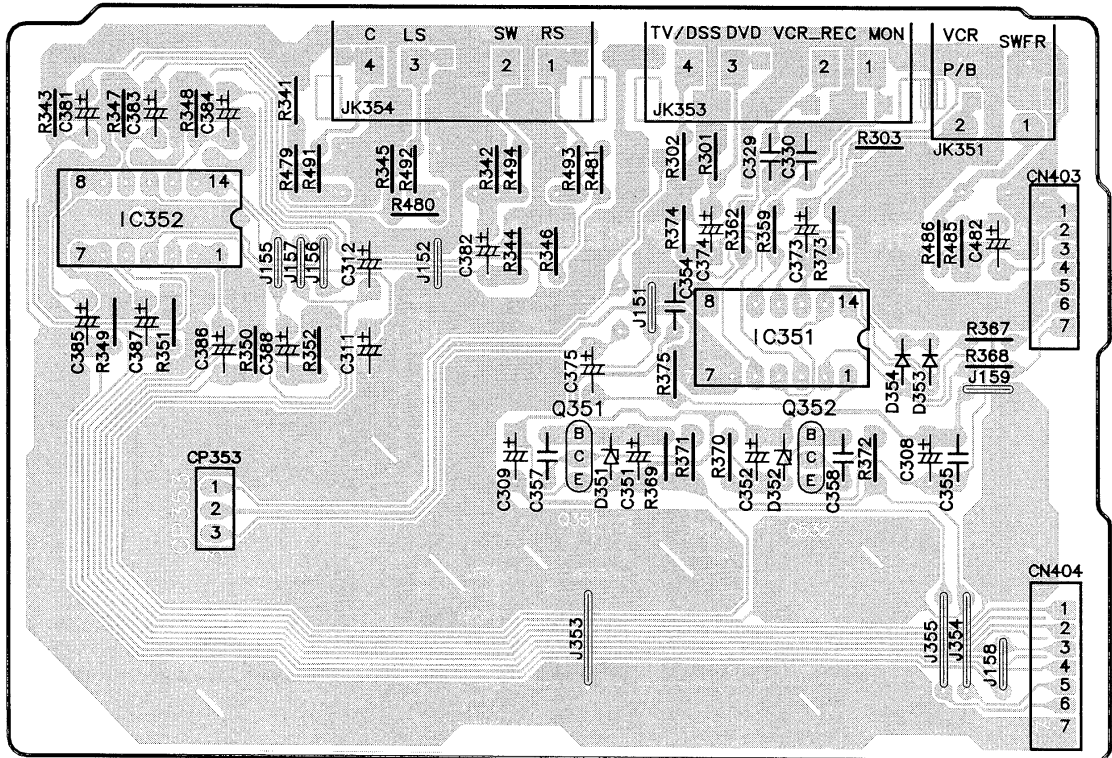

F TUNER P.C.B. (REP2254A-T)

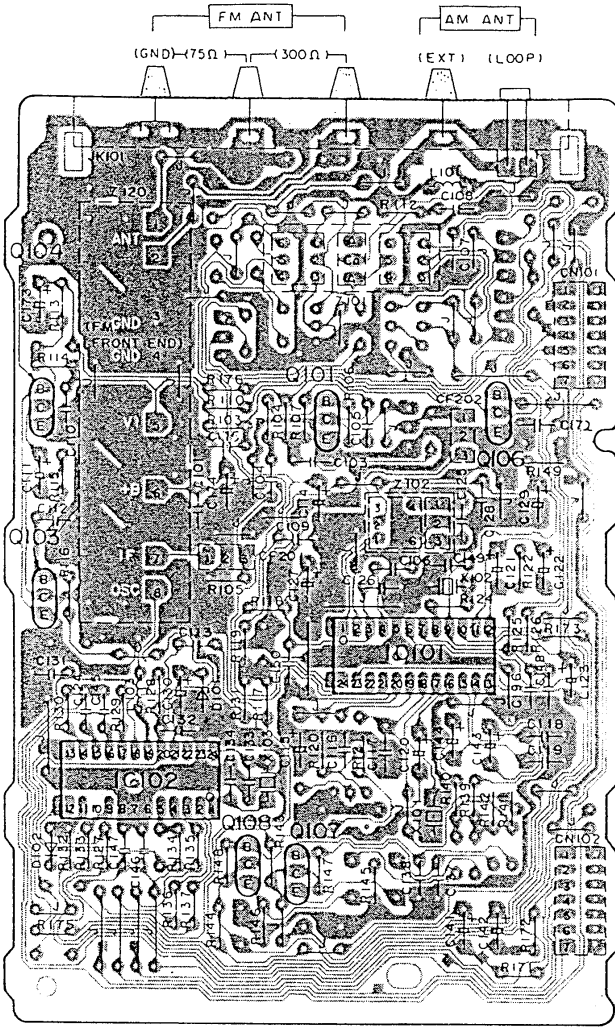

G TUNER PACK P.C.B. (REP1999B)

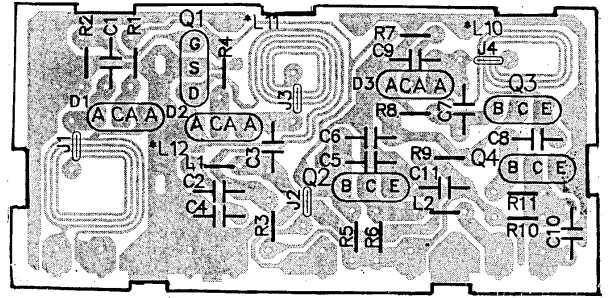

M AUDIO/VIDEO IN P.C.B. (REP2628B-S)

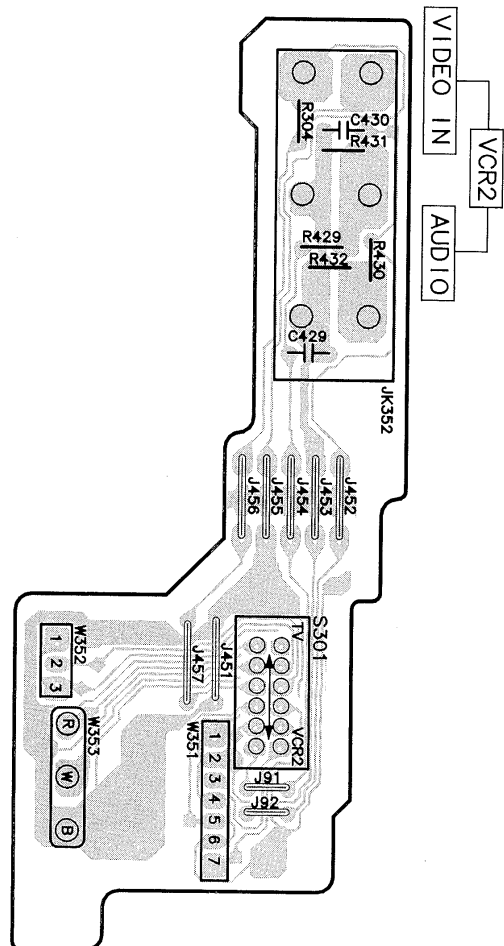

C AC IN/OUT P.C.B. (REP2629C-P)... P (REP2629D-P)... PC

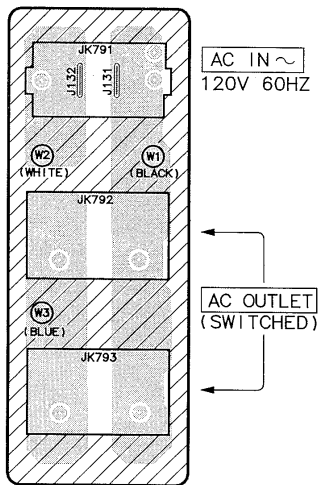

A MAIN P.C.B. (REP2630A-M)

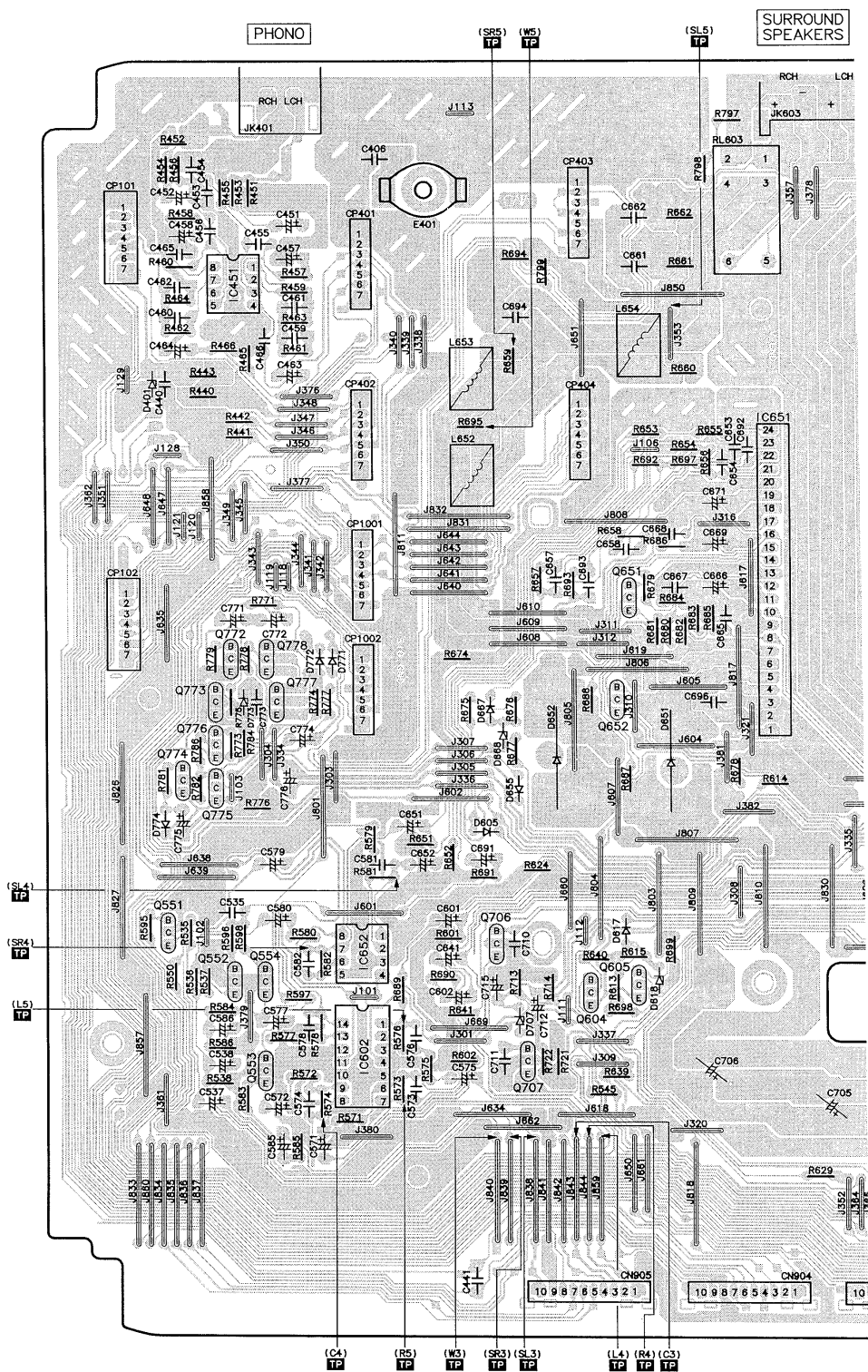

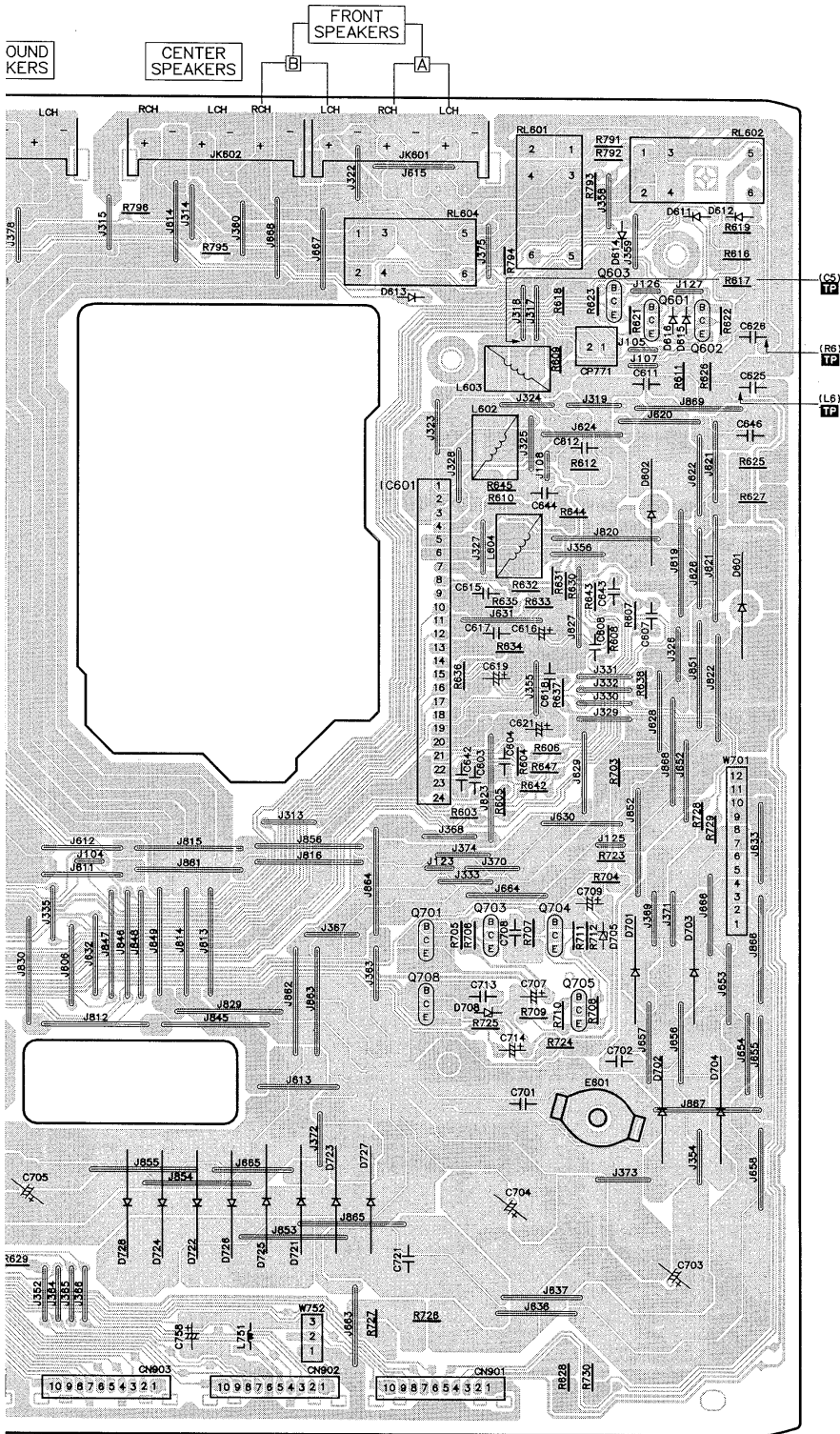

J POWER P.C.B. (REP2629C-P)... P
(REP2629D-P)... PC

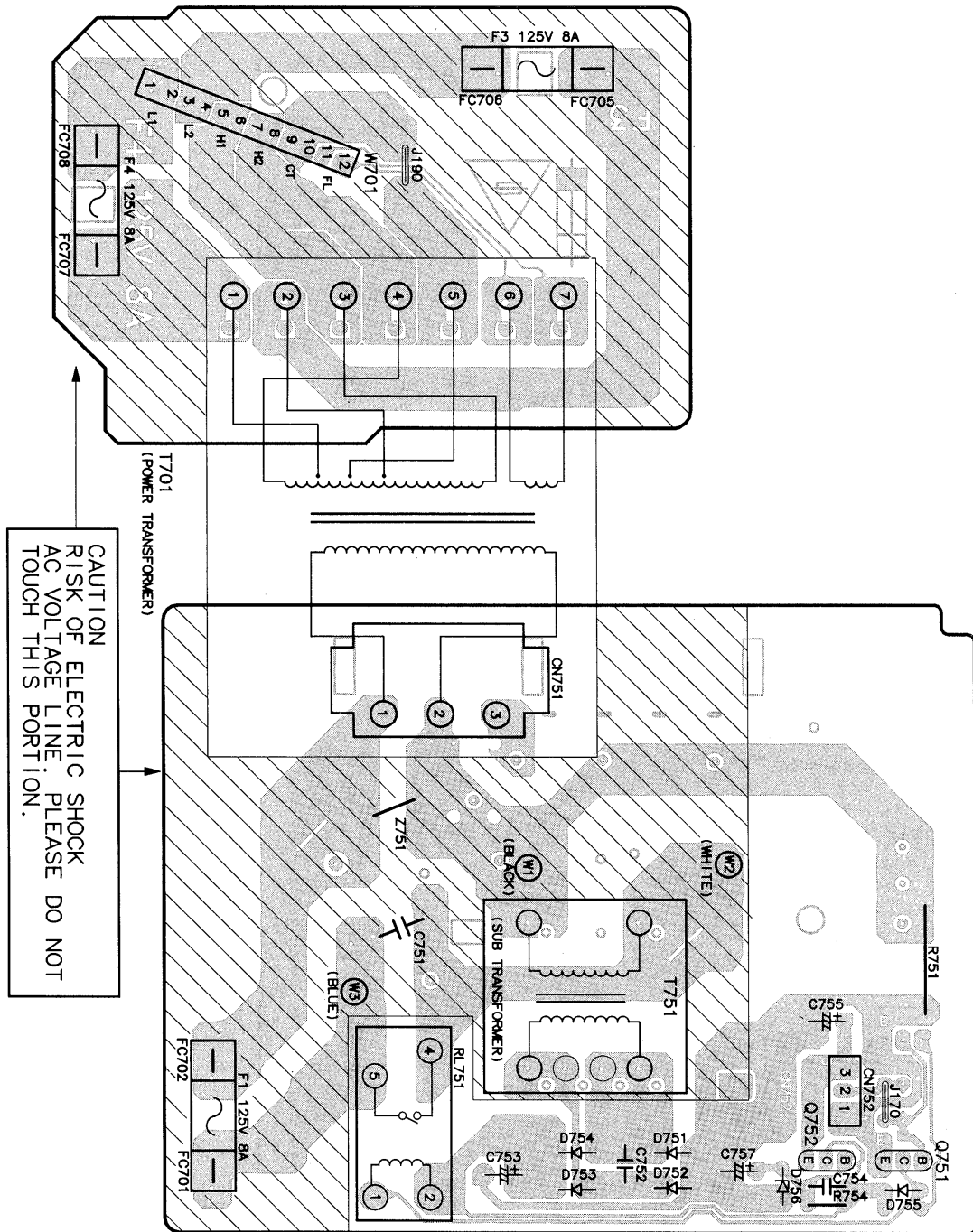

H TRANSFORMER P.C.B. (REP2630A-M)

Wiring Connection Diagram

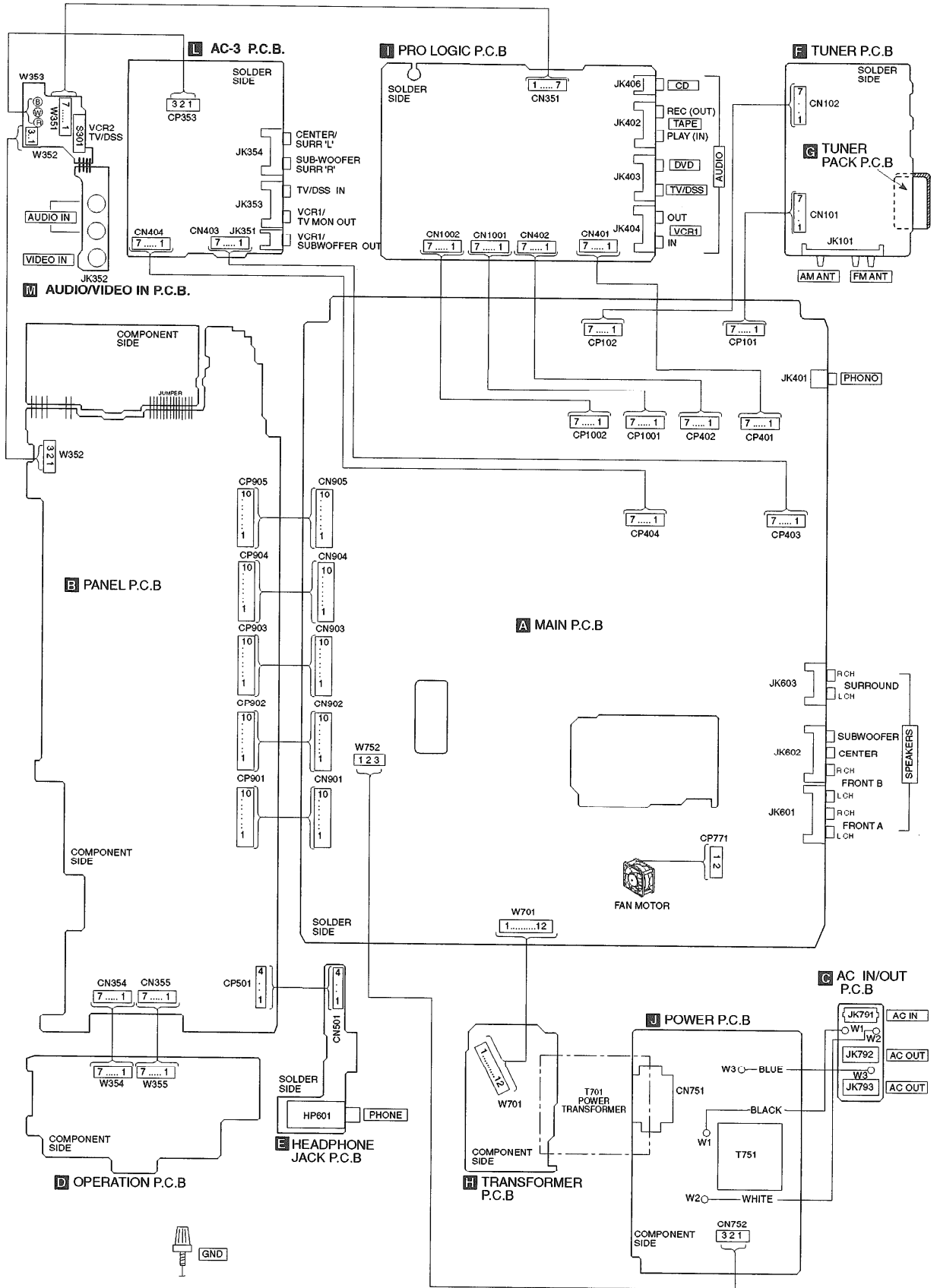

Cabinet Parts Location

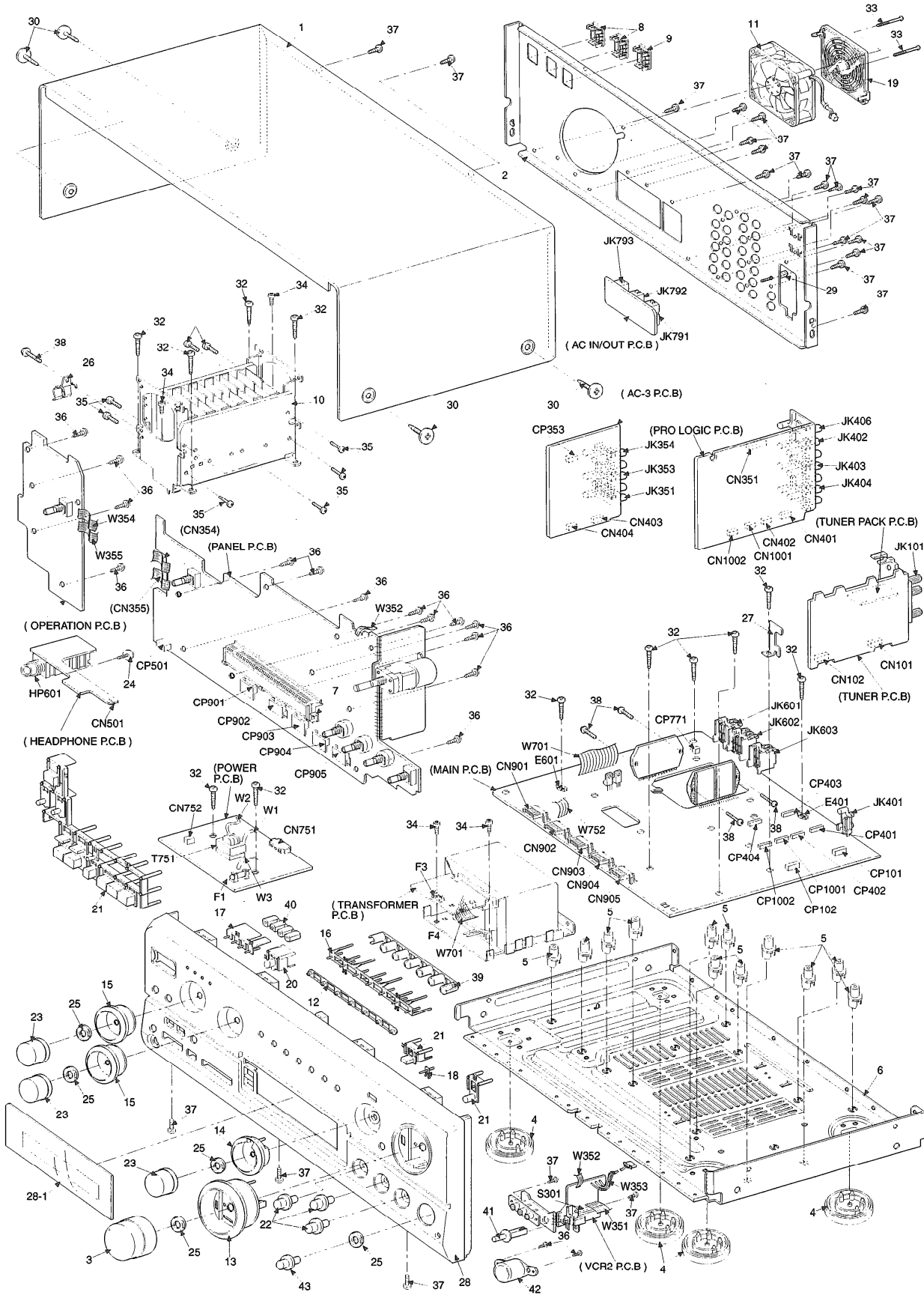

■ Replacement Parts List

Notes: * Important safety notice :

 Components identified by \triangle mark have special characteristics important for safety.

Furthermore, special parts which have purposes of fire-retardant (resistors), high-quality sound (capacitors), low-noise (resistors), etc. are used. When replacing any of components, be sure to use only manufacturer's specified parts shown in the parts list.

 * The parenthesized in the Remarks columns specify the areas. (Refer to the cover page for area.)
 Parts without these indication can be used for all areas.

* [M] in Remarks column indicates parts that are supplied by MESA.

* Remote Control Unit : Supply period for three years from terminal of production.

* The "(SF)" mark denotes the standard part.

Ref No.	Part No.	Part Name & Description	Remarks	Ref No.	Part No.	Part Name & Description	Remarks	Ref No.	Part No.	Part Name & Description	Remarks
		CABINET AND CHASSIS									
				37	XTBS3+8JFZ1	SCREW	[M]	Q101	2SC2787LTA	TRANSISTOR	[M]
				38	XTW3+15T	SCREW	[M]	Q103	2SC2785FETA	TRANSISTOR	[M]
1	RKM0375-K	TOP CABINET	[M]	39	RMV0158	SEL LED COVER	[M]	Q104	2SC2785FETA	TRANSISTOR	[M]
2	RGR0265B-A	REAR PANEL	[M](P)	40	RMV0159	P-L LED COVER	[M]	Q106	RVTDTA143XST	TRANSISTOR	[M]
2	RGR0265B-B	REAR PANEL	[M](PC)	41	RGU1618-K	SELECTOR BUTTON	[M]	Q107	2SC3311ARTA	TRANSISTOR	[M]
3	RGW0278-K	VOLUME KNOB	[M]	42	RGK0996-N	SUBWOOFER VOL.RING	[M]	Q108	2SC3311ARTA	TRANSISTOR	[M]
4	RKA0079-A	FOOT	[M]	43	RGW0281-K	SUBWOOFER KNOB	[M]	Q351	2SD592AQSTA	TRANSISTOR	[M]
5	RKQ0089-J	PCB HOLDER	[M]					Q352	2SB621AQSTA	TRANSISTOR	[M]
6	RMK0350	BOTTOM CHASSIS	[M]			INTEGRATED CIRCUITS		Q401	2SK381CTA	TRANSISTOR	[M]
7	RMN0372A	FL HOLDER	[M]					Q402	2SK381CTA	TRANSISTOR	[M]
8	SJS9233A	AC OUTLET COVER	[M]	IC101	LA1832A	IC, IF/MPX	[M]	Q501	2SJ40CTA	TRANSISTOR	[M]
9	SJS9234A	AC INLET COVER	[M]	IC102	LC7218	IC, PLL	[M]	Q502	2SJ40CTA	TRANSISTOR	[M]
10	RXX0194	HEAT SINK UNIT	[M]	IC351	NJM2279D	IC, VIDEO SELECTOR SW	[M]	Q505	2SD1915FTA	TRANSISTOR	[M]
11	REM0080	FAN UNIT	[M]	IC352	AN6554F	IC, OSD AMP	[M]	Q506	2SD1915FTA	TRANSISTOR	[M]
12	RGK0992-N	LIGHT GUIDE RING	[M]	IC401	TC9163AN	IC, SELECTOR	[M]	Q551	2SD1915FTA	TRANSISTOR	[M]
13	RGK0993-N	VOLUME RING	[M]	IC402	UPC4570C	IC, TONE CONTROL	[M]	Q552	2SD1915FTA	TRANSISTOR	[M]
14	RGK0994-N	SELECTOR RING	[M]	IC451	AN6558F	IC, OP AMP	[M]	Q553	2SD1915FTA	TRANSISTOR	[M]
15	RGK0995-N	PRO LOGIC RING	[M]	IC501	BA6218	IC, MOTOR DRIVER	[M]	Q554	2SD1915FTA	TRANSISTOR	[M]
16	RGL0401-Q	LIGHT GUIDE	[M]	IC511	UPC4570C	IC, TONE CONTROL	[M]	Q601	RVTDTA143XST	TRANSISTOR	[M]
17	RGL0402-Q	P/L LIGHT GUIDE	[M]	IC551	UPC4570C	IC, TONE CONTROL	[M]	Q602	RVTDTA143XST	TRANSISTOR	[M]
18	RGL0403-Q	6CH LIGHT GUIDE	[M]	IC552	UPC4570C	IC, TONE CONTROL	[M]	Q603	RVTDTA143XST	TRANSISTOR	[M]
19	RGQ0231-K	FAN COVER	[M]	IC601	RSN310R36-P	IC, HIC	[M]	Q604	RVTDTA114EST	TRANSISTOR	[M]
20	RGU1616-K	HELP BUTTON	[M]	IC602	AN6554F	IC, OSD AMP	[M]	Q605	RVTDTA114EST	TRANSISTOR	[M]
21	RGU1617A-K	MODE BUTTON	[M]	IC651	RSN310R36-P	IC, HIC	[M]	Q651	RVTDTA143XST	TRANSISTOR	[M]
22	RGW0279-K	TONE KNOB	[M]	IC652	UPC4570C	IC, TONE CONTROL	[M]	Q652	RVTDTA143XST	TRANSISTOR	[M]
23	RGW0280-K	SELECTOR KNOB	[M]	IC901	M38B57M6100F	IC, MICOM	[M]	Q701	2SD2374PQAU	TRANSISTOR	[M]
24	RHD26016	SCREW	[M]	IC903	BU2090	IC, EXPANDER	[M]	Q703	2SC1740SSTA	TRANSISTOR	[M]
25	RHN90001	M9 NUT	[M]	IC1001	LA2786L	IC, DPL	[M]	Q704	2SC1740SSTA	TRANSISTOR	[M]
26	RMC0158-S	TRANSISTOR HOLDER	[M]	IC1002	LV1016L	IC, SURR DECODER	[M]	Q705	2SC1740SSTA	TRANSISTOR	[M]
27	RMQ0709	TUNER PCB BRACKET	[M]	IC1003	TC9214P	IC, SELECTOR	[M]	Q706	2SC3940AQSTA	TRANSISTOR	[M]
28	RFKGAAX920PK	FRONT PANEL ASS'Y	[M]	IC1004	TC9162AN	IC, SELECTOR	[M]	Q707	2SA1534AQRTA	TRANSISTOR	[M]
28-1	RKW0533A-Q	FL WINDOW	[M]	IC1151	UPC4570C	IC, TONE CONTROL	[M]	Q708	2SB1548PQAU	TRANSISTOR	[M]
29	SNE2123	EARTH TERMINAL	[M]					Q751	RVTDTA143XST	TRANSISTOR	[M]
30	SNE2129-1	SCREW (CABINET)	[M]			TRANSISTORS		Q752	2SC3940AQSTA	TRANSISTOR	[M]
32	XTB3+20JFZ	SCREW	[M]					Q772	2SC1740SSTA	TRANSISTOR	[M]
33	XTB3+35JFZ	SCREW (FAN)	[M]	Q1	2SK544F-AC	TRANSISTOR	[M]	Q773	2SB621AQSTA	TRANSISTOR	[M]
34	XTB3+8FFZ	SCREW	[M]	Q2	2SC2786MTA	TRANSISTOR	[M]	Q774	2SA933SSTA	TRANSISTOR	[M]
35	XTB3+8JFZ	SCREW	[M]	Q3	2SC2787FL1TA	TRANSISTOR	[M]	Q775	RVTDTA114EST	TRANSISTOR	[M]
36	XTBS26+10J	SCREW	[M]	Q4	2SC2787FL1TA	TRANSISTOR	[M]	Q776	2SC1740SSTA	TRANSISTOR	[M]

Ref No.	Part No.	Part Name & Description	Remarks	Ref No.	Part No.	Part Name & Description	Remarks	Ref No.	Part No.	Part Name & Description	Remarks
Q777	2SA933SSTA	TRANSISTOR	[M]	D723	1N5402BM21	DIODE	[M]			SWITCHES	
Q778	2SA933SSTA	TRANSISTOR	[M]	D724	1N5402BM21	DIODE	[M]				
Q901	RVTDC114YST	TRANSISTOR	[M]	D725	1N5402BM21	DIODE	[M]	S301	RSP2D009-J	SWITCH	[M]
Q902	2SA933SSTA	TRANSISTOR	[M]	D726	1N5402BM21	DIODE	[M]	S946	EVQ21405R	SW, POWER	[M]
Q908	RVTDC114YST	TRANSISTOR	[M]	D727	1N5402BM21	DIODE	[M]	S948	EVQ21405R	SW, MUTING	[M]
Q1001	2SC3940AQSTA	TRANSISTOR	[M]	D728	1N5402BM21	DIODE	[M]	S950	EVQ21405R	SW, FM MODE	[M]
Q1681	2SD1915FTA	TRANSISTOR	[M]	D751	1SR35200TB	DIODE	[M]	S951	EVQ21405R	SW, BAND	[M]
Q1682	2SD1915FTA	TRANSISTOR	[M]	D752	1SR35200TB	DIODE	[M]	S952	EVQ21405R	SW, DOWN	[M]
				D753	1SR35200TB	DIODE	[M]	S953	EVQ21405R	SW, UP	[M]
		DIODES		D754	1SR35200TB	DIODE	[M]	S955	EVQ21405R	SW, MEMO	[M]
				D755	RVD1SS133TA	DIODE	[M]▲	S956	EVQ21405R	SW, T.MODE	[M]
D1	SVC211SPA-AL	DIODE	[M]	D756	MTZJ6R8BTA	DIODE	[M]▲	S958	EVQ21405R	SW, HELP-RESET	[M]
D2	SVC211SPA-AL	DIODE	[M]	D771	RVD1SS133TA	DIODE	[M]▲	S976	EVQ21405R	SW, 6CH	[M]
D3	SVC211SPA-AL	DIODE	[M]	D772	RVD1SS133TA	DIODE	[M]▲	S980	EVQ21405R	SW, SP_A	[M]
D101	MTZJ5R1BTA	DIODE	[M]	D773	MTZJ11CTA	DIODE	[M]▲	S981	EVQ21405R	SW, SP_B	[M]
D102	RVD1SS133TA	DIODE	[M]	D774	RVD1SS133TA	DIODE	[M]▲	S982	EVQ21405R	SW, LOUDNESS	[M]
D351	MTZJ5R6BTA	DIODE	[M]	D901	1SS291TA	DIODE	[M]	S985	EVQ21405R	SW, CENTER MODE	[M]
D352	MTZJ5R6BTA	DIODE	[M]	D903	MTZJ4R7BTA	DIODE	[M]	S986	EVQ21405R	SW, DELAY	[M]
D353	RVD1SS133TA	DIODE	[M]	D906	MA167ATA	DIODE	[M]				
D354	RVD1SS133TA	DIODE	[M]	D921	RVD1SS133TA	DIODE	[M]			CONNECTORS	
D401	MTZJ7R5CTA	DIODE	[M]	D923	RVD1SS133TA	DIODE	[M]	CN101	RJU057W007	7P CONNECTOR	[M]
D403	RVD1SS133TA	DIODE	[M]	D924	MTZJ3R9ATA	DIODE	[M]	CN102	RJU057W007	7P CONNECTOR	[M]
D404	RVD1SS133TA	DIODE	[M]	D931	SLR325VCT31	DIODE	[M]	CN351	RJS7T6ZA	7PIN CONNECTOR	[M]
D601	RK306LFU1	DIODE	[M]	D932	SLR325VCT31	DIODE	[M]	CN401	RJU100W07	7P CONNECTOR	[M]
D602	RK306LFU1	DIODE	[M]	D933	SLR325VCT31	DIODE	[M]	CN402	RJU100W07	7P CONNECTOR	[M]
D605	RVD1SS133TA	DIODE	[M]	D934	SLR325VCT31	DIODE	[M]	CN403	RJU100W07	7P CONNECTOR	[M]
D611	RVD1SS133TA	DIODE	[M]	D935	SLR325VCT31	DIODE	[M]	CN404	RJU100W07	7P CONNECTOR	[M]
D612	RVD1SS133TA	DIODE	[M]	D936	SLR325VCT31	DIODE	[M]	CN404	RJU100W07	7P CONNECTOR	[M]
D613	RVD1SS133TA	DIODE	[M]	D937	SLR325VCT31	DIODE	[M]	CN501	RJU100W04	4P CONNECTOR	[M]
D614	RVD1SS133TA	DIODE	[M]	D938	SLR325VCT31	DIODE	[M]	CN751	SJS305-1	3P CONNECTOR	[M]
D615	RVD1SS133TA	DIODE	[M]	D939	SLR325VCT31	DIODE	[M]	CN752	RJS1A6603T1	3 PIN TAPING CONNECT	[M]
D616	RVD1SS133TA	DIODE	[M]	D940	SLR325VCT31	DIODE	[M]	CN901	RJU003K010M1	10P B/B CONNECTOR	[M]
D617	RVD1SS133TA	DIODE	[M]	D941	SLR325VCT31	DIODE	[M]	CN902	RJU003K010M1	10P B/B CONNECTOR	[M]
D618	MTZJ15CTA	DIODE	[M]	D942	SLR325MCT31	DIODE	[M]	CN903	RJU003K010M1	10P B/B CONNECTOR	[M]
D651	RK306LFU1	DIODE	[M]	D1001	MTZJ10CTA	DIODE	[M]	CN904	RJU003K010M1	10P B/B CONNECTOR	[M]
D652	RK306LFU1	DIODE	[M]	D1002	MA700ATA	DIODE	[M]	CN905	RJU003K010M1	10P B/B CONNECTOR	[M]
D655	RVD1SS133TA	DIODE	[M]					CN1001	RJU100W07	7P CONNECTOR	[M]
D667	RVD1SS133TA	DIODE	[M]			VARIABLE RESISTORS		CN1002	RJU100W07	7P CONNECTOR	[M]
D668	MTZJ15CTA	DIODE	[M]					CP101	RJT057W007-1	7P CONNECTOR	[M]
D701	1N5402BM21	DIODE	[M]	VR501	EUWM6A026B15	VR, MOTOR VOLUME	[M]	CP102	RJT057W007-1	7P CONNECTOR	[M]
D702	1N5402BM21	DIODE	[M]	VR502	EW00YAF20G15	VR, BALANCE CONTROL	[M]	CP353	RJP3G4YA	CONNECTOR	[M]
D703	1N5402BM21	DIODE	[M]	VR503	EVJ06LF04A15	VR, SUBWOOFER	[M]	CP401	RJT100W07	7P CONNECTOR	[M]
D704	1N5402BM21	DIODE	[M]	VR511	EW01XA020C15	VR, TONE CONTROL	[M]	CP402	RJT100W07	7P CONNECTOR	[M]
D705	MTZJ6R2BTA	DIODE	[M]	VR512	EW01XA020C15	VR, TONE CONTROL	[M]	CP403	RJT100W07	7P CONNECTOR	[M]
D707	MTZJ27DTA	DIODE	[M]	VR901	EVQVBHFK112B	VR, BALANCE CONTROL	[M]	CP404	RJT100W07	7P CONNECTOR	[M]
D708	MTZJ15CTA	DIODE	[M]	VR902	EVQVBHFK112B	VR, BALANCE CONTROL	[M]	CP501	RJT100W04	4P CONNECTOR	[M]
D721	1N5402BM21	DIODE	[M]	VR903	EVQVBHFK112B	VR, BALANCE CONTROL	[M]	CP771	SJT3213	CONNECTOR (FAN)	[M]
D722	1N5402BM21	DIODE	[M]					CP901	RJT003K010M1	10P CONNECTOR	[M]

Ref No.	Part No.	Part Name & Description	Remarks	Ref No.	Part No.	Part Name & Description	Remarks	Ref No.	Part No.	Part Name & Description	Remarks
CP902	RJT003K010M1	10P CONNECTOR	[M]	RL751	RSY0021-0	12 TV-8 RELAY	[M](PC)			EARTH TERMINALS	
CP903	RJT003K010M1	10P CONNECTOR	[M]								
CP904	RJT003K010M1	10P CONNECTOR	[M]			OSCILLATORS		E401	SNE1004-2	EARTH TERMINAL	[M]
CP905	RJT003K010M1	10P CONNECTOR	[M]					E601	SNE1004-2	EARTH TERMINAL	[M]
CP1001	RJT100W07	7P CONNECTOR	[M]	X101	RSXZ456KM07M	CERAMIC OSCILLATOR	[M]				
CP1002	RJT100W07	7P CONNECTOR	[M]	X102	RLFDGTD011	FM REZONATOR	[M]			WIRES	
				X103	SVQ49U722T-S	CRYSTAL 7.2MHZ	[M]				
		COILS & TRANSFORMERS									
						DISPLAY TUBE					
L1	RLQZP1R2JT-Y	RF CHOKE COIL	[M]	FL901	RSL0254-F	FL	[M]	W1	REE0857	WIRE UNIT	[M]
L2	RLQZPR47KT-Y	RF CHOKE COIL	[M]					W2	REE0858	WIRE UNIT	[M]
L101	ELESN1R5MA	CHOKE COIL	[M]					W3	REE0859	WIRE UNIT	[M]
L103	ELEXT47MA9	CHOKE COIL	[M]			FUSES		W351	RWJ1807260CQ	WIRE	[M]
L501	RLQZP1R0KT-Y	AXIAL COIL	[M]					W352	RWJ1803200CC	WIRE	[M]
L502	RLQZP1R0KT-Y	AXIAL COIL	[M]	F1	XBA1C80NBAL	FUSE	[M]▲	W353	REX0800	SHIELD WIRE	[M]
L602	RLQYR73MW-E	CHOKE COIL	[M]	F3	XBA1C80NBAL	FUSE	[M]▲	W354	RWJ1807200CC	7P FLAT CABLE	[M]
L603	RLQYR73MW-E	CHOKE COIL	[M]	F4	XBA1C80NBAL	FUSE	[M]▲	W355	RWJ1807200CC	7P FLAT CABLE	[M]
L604	RLQYR73MW-E	CHOKE COIL	[M]					W701	RWJ1812220CC	WIRE UNIT	[M]
L652	RLQYR73MW-E	CHOKE COIL	[M]			FUSE HOLDERS		W752	RWJ1803290CQ	WIRE	[M]
L653	RLQYR73MW-E	CHOKE COIL	[M]							PACKING MATERIALS	
L654	RLQYR73MW-E	CHOKE COIL	[M]	FC701	RJR0169T	FUSE HOLDER	[M]	P1	RPN0966	POLYFOAM	[M]
L751	RLQB101KTA-Y	CHOKE COIL	[M]	FC702	RJR0169T	FUSE HOLDER	[M]	P2	RPF00005	MIRAMAT BAG	[M]
L901	RLQB101KTA-Y	CHOKE COIL	[M]	FC705	RJR0169T	FUSE HOLDER	[M]	P3	RPG3680	PACKING CASE	[M]
L1051	RLQB101KTA-Y	CHOKE COIL	[M]	FC706	RJR0169T	FUSE HOLDER	[M]	P4	SPB1061	BAG	[M]
T701	RTP1Q5C012-V	POWER TRANSFORMER	[M]▲	FC707	RJR0169T	FUSE HOLDER	[M]	P5	SPSD152	ACCESSORY BOX	[M]
T751	RTP1H5C003-V	SUB TRANSFORMER	[M]▲	FC708	RJR0169T	FUSE HOLDER	[M]			ACCESSORIES	
		COMPONENT COMBINATION				JACKS					
								A1	RAK-SA937MK	REMOTE CONTROL	[M]
Z101	RLA2Z002M-T	AM ANT. COIL	[M]	JK101	RJH4405	JK, ANT TERMINAL	[M]	A1-1	BEV11M202A	R/C BATTERY COVER	[M]
Z102	RLI2Z006M-T	AM IFT	[M]	JK351	RJH3210N	JK, 2P RCA PIN	[M]	A2	RSA0010	LOOP ANT UNIT	[M]
Z751	ERZV10V511CS	ZNR	[M]▲	JK352	SJFK5-2A	JK, VCR IN	[M]	A3	SJA172	AC CORD	[M](SF)▲
Z891	RCD12042TE	REMOTE SENSOR	[M]	JK353	SJF3069-3N	JK, RCA PIN	[M]	A4	RSA0006	FM ANTENNA WIRE	[M]
				JK354	SJF3069-16N	JK, RCA TERMINAL	[M]	A5	RQT4167-P	O/I BOOK FOR REMOTE	[M]
		CERAMIC FILTERS		JK401	SJF3068-7N	JK, RCA TERMINAL	[M]	A5	RQT4169-C	O/I BOOK FOR REMOTE	[M](PC)
				JK402	SJF3069N	JK, LINE IN	[M]	A5	RQT4208-P	O/I BOOK	[M]
CF201	RLFFETMGD01L	CERAMIC FILTER	[M]	JK403	SJF3069N	JK, LINE IN	[M]	A5	RQT4210-C	O/I BOOK	[M](PC)
CF202	RLFFETMGD01L	CERAMIC FILTER	[M]	JK404	SJF3069N	JK, LINE IN	[M]				
CF901	RVCBST4R00MT	CERAMIC OSCILLATOR	[M]	JK406	SJF3068-7N	JK, RCA TERMINAL	[M]				
CF1051	EF0EC8004T4	CERAMIC OSCILLATOR	[M]	JK601	RJH5601	JK, SP TERMINAL	[M]				
				JK602	RJH5601	JK, SP TERMINAL	[M]				
		RELAYS		JK603	RJR0054	JK, SP TERMINAL	[M]				
				JK791	SJS9234B	JK, AC INLET	[M]▲				
RL601	RSY0013M-0	RELAY	[M]	JK792	SJS9233B	JK, AC OUTLET	[M]▲				
RL602	RSY0013M-0	RELAY	[M]	JK793	SJS9233B	JK, AC OUTLET	[M]▲				
RL603	RSY0013M-0	RELAY	[M]	HP601	RJH63TA01	JK, HEADPHONE	[M]				
RL604	RSY0013M-0	RELAY	[M]								
RL751	RSY0019M-0	12V TV-5 RELAY	[M](P)▲								

Resistors & Capacitors

Notes : * Important safety notice:

Components identified by \triangle mark have special characteristics important for safety.

Furthermore, special parts which have purposes of fire-retardant (resistors), high-quality sound (capacitors), low-noise (resistors), etc. are used. When replacing any of components, be sure to use only manufacturer's specified parts shown in the parts list.

* Capacitor values are in microfarad (μ F) unless specified otherwise, P=Pico-farads (pF) F=Farads (F)

* Resistors values are in ohms, unless specified otherwise, 1k=1,000(OHM), 1M=1,000k(OHM)

Ref No.	Part No.	Values & Remarks	Ref No.	Part No.	Values & Remarks	Ref No.	Part No.	Values & Remarks	Ref No.	Part No.	Values & Remarks
		RESISTORS									
R1	ERDS2TJ104T	100K 1/4W [M]	R136	ERDS2TJ102T	1K 1/4W [M]	R373	ERDS2TJ103T	10K 1/4W [M]	R453	ERDS2TJ821T	820 1/4W [M]
R2	ERDS2TJ104T	100K 1/4W [M]	R137	ERDS2TJ102T	1K 1/4W [M]	R374	ERDS2TJ103T	10K 1/4W [M]	R454	ERDS2TJ821T	820 1/4W [M]
R3	ERDS2TJ221T	220 1/4W [M]	R139	ERDS2TJ272T	2.7K 1/4W [M]	R375	ERDS2TJ103T	10K 1/4W [M]	R455	ERDS2TJ563T	56K 1/4W [M]
R4	ERDS2TJ104T	100K 1/4W [M]	R140	ERDS2TJ272T	2.7K 1/4W [M]	R401	ERDS2TJ102T	1K 1/4W [M]	R456	ERDS2TJ563T	56K 1/4W [M]
R5	ERDS2TJ564T	560K 1/4W [M]	R141	ERDS2TJ103T	10K 1/4W [M]	R402	ERDS2TJ102T	1K 1/4W [M]	R457	ERDS2TJ271T	270 1/4W [M]
R6	ERDS2TJ391T	390 1/4W [M]	R142	ERDS2TJ103T	10K 1/4W [M]	R405	ERDS2TJ102T	1K 1/4W [M]	R458	ERDS2TJ271T	270 1/4W [M]
R7	ERDS2TJ272T	2.7K 1/4W [M]	R143	ERDS2TJ222T	2.2K 1/4W [M]	R406	ERDS2TJ102T	1K 1/4W [M]	R459	ERDS2TJ680T	68 1/4W [M]
R8	ERDS2TJ684T	680K 1/4W [M]	R144	ERDS2TJ222T	2.2K 1/4W [M]	R407	ERDS2TJ102T	1K 1/4W [M]	R460	ERDS2TJ680T	68 1/4W [M]
R9	ERDS2TJ391T	390 1/4W [M]	R145	ERDS2TJ102T	1K 1/4W [M]	R408	ERDS2TJ102T	1K 1/4W [M]	R461	ERDS2TJ184T	180K 1/4W [M]
R10	ERDS2TJ391T	390 1/4W [M]	R146	ERDS2TJ102T	1K 1/4W [M]	R409	ERDS2TJ102T	1K 1/4W [M]	R462	ERDS2TJ184T	180K 1/4W [M]
R11	ERDS2TJ684T	680K 1/4W [M]	R147	ERDS2TJ474T	470K 1/4W [M]	R410	ERDS2TJ102T	1K 1/4W [M]	R463	ERDS2TJ123T	12K 1/4W [M]
R103	ERDS2TJ151T	150 1/4W [M]	R148	ERDS2TJ474T	470K 1/4W [M]	R411	ERDS2TJ102T	1K 1/4W [M]	R464	ERDS2TJ123T	12K 1/4W [M]
R104	ERDS2TJ102T	1K 1/4W [M]	R149	ERDS2TJ680T	68 1/4W [M]	R412	ERDS2TJ102T	1K 1/4W [M]	R465	ERDS2TJ563T	56K 1/4W [M]
R105	ERDS2TJ471T	470 1/4W [M]	R171	ERDS2TJ102T	1K 1/4W [M]	R413	ERDS2TJ102T	1K 1/4W [M]	R466	ERDS2TJ563T	56K 1/4W [M]
R106	ERDS2TJ224T	220K 1/4W [M]	R172	ERDS2TJ102T	1K 1/4W [M]	R414	ERDS2TJ102T	1K 1/4W [M]	R473	ERDS2TJ102T	1K 1/4W [M]
R107	ERDS2TJ471T	470 1/4W [M]	R173	ERDS2TJ471T	470 1/4W [M]	R415	ERDS2TJ102T	1K 1/4W [M]	R474	ERDS2TJ102T	1K 1/4W [M]
R110	ERDS2TJ102T	1K 1/4W [M]	R175	ERDS2TJ102T	1K 1/4W [M]	R416	ERDS2TJ102T	1K 1/4W [M]	R477	ERDS2TJ103T	10K 1/4W [M]
R112	ERDS2TJ104T	100K 1/4W [M]	R176	ERDS2TJ391T	390 1/4W [M]	R417	ERDS2TJ473T	47K 1/4W [M]	R478	ERDS2TJ104T	100K 1/4W [M]
R113	ERDS2TJ103T	10K 1/4W [M]	R301	ERDS2TJ750T	75 1/4W [M]	R418	ERDS2TJ473T	47K 1/4W [M]	R479	ERDS2TJ393T	39K 1/4W [M]
R114	ERDS2TJ562T	5.6K 1/4W [M]	R302	ERDS2TJ750T	75 1/4W [M]	R419	ERDS2TJ104T	100K 1/4W [M]	R480	ERDS2TJ393T	39K 1/4W [M]
R115	ERDS2TJ561T	560 1/4W [M]	R303	ERDS2TJ750T	75 1/4W [M]	R420	ERDS2TJ104T	100K 1/4W [M]	R481	ERDS2TJ393T	39K 1/4W [M]
R116	ERDS2TJ102T	1K 1/4W [M]	R304	ERDS2TJ750T	75 1/4W [M]	R421	ERDS2TJ104T	100K 1/4W [M]	R485	ERDS2TJ104T	100K 1/4W [M]
R117	ERDS2TJ104T	100K 1/4W [M]	R341	ERDS2TJ103T	10K 1/4W [M]	R422	ERDS2TJ104T	100K 1/4W [M]	R486	ERDS2TJ102T	1K 1/4W [M]
R118	ERDS2TJ562T	5.6K 1/4W [M]	R342	ERDS2TJ104T	100K 1/4W [M]	R423	ERDS2TJ102T	1K 1/4W [M]	R491	ERDS2TJ102T	1K 1/4W [M]
R119	ERDS2TJ822T	8.2K 1/4W [M]	R343	ERDS2TJ104T	100K 1/4W [M]	R424	ERDS2TJ102T	1K 1/4W [M]	R492	ERDS2TJ102T	1K 1/4W [M]
R120	ERDS2TJ473T	47K 1/4W [M]	R344	ERDS2TJ104T	100K 1/4W [M]	R425	ERDS2TJ103T	10K 1/4W [M]	R493	ERDS2TJ102T	1K 1/4W [M]
R121	ERDS2TJ332T	3.3K 1/4W [M]	R345	ERDS2TJ103T	10K 1/4W [M]	R426	ERDS2TJ103T	10K 1/4W [M]	R494	ERDS2TJ102T	1K 1/4W [M]
R122	ERDS2TJ272T	2.7K 1/4W [M]	R346	ERDS2TJ103T	10K 1/4W [M]	R427	ERDS2TJ103T	10K 1/4W [M]	R501	ERDS2TJ222T	2.2K 1/4W [M]
R124	ERDS2TJ271T	270 1/4W [M]	R347	ERDS2TJ104T	100K 1/4W [M]	R428	ERDS2TJ332T	3.3K 1/4W [M]	R502	ERDS2TJ222T	2.2K 1/4W [M]
R125	ERDS2TJ472T	4.7K 1/4W [M]	R348	ERDS2TJ104T	100K 1/4W [M]	R429	ERDS2TJ102T	1K 1/4W [M]	R503	ERDS2TJ103T	10K 1/4W [M]
R126	ERDS2TJ472T	4.7K 1/4W [M]	R349	ERDS2TJ104T	100K 1/4W [M]	R430	ERDS2TJ102T	1K 1/4W [M]	R504	ERDS2TJ103T	10K 1/4W [M]
R127	ERDS2TJ103T	10K 1/4W [M]	R350	ERDS2TJ104T	100K 1/4W [M]	R431	ERDS2TJ224T	220K 1/4W [M]	R505	ERDS2TJ103T	10K 1/4W [M]
R128	ERDS2TJ820T	82 1/4W [M]	R351	ERDS2TJ104T	100K 1/4W [M]	R432	ERDS2TJ224T	220K 1/4W [M]	R506	ERDS2TJ103T	10K 1/4W [M]
R129	ERDS2TJ473T	47K 1/4W [M]	R352	ERDS2TJ104T	100K 1/4W [M]	R433	ERDS2TJ102T	1K 1/4W [M]	R507	ERDS2TJ153T	15K 1/4W [M]
R130	ERDS2TJ102T	1K 1/4W [M]	R359	ERDS2TJ750T	75 1/4W [M]	R434	ERDS2TJ102T	1K 1/4W [M]	R508	ERDS1FVJ2R2T	2.2 1/2W [M]
R131	ERDS2TJ102T	1K 1/4W [M]	R362	ERDS2TJ750T	75 1/4W [M]	R435	ERDS2TJ473T	47K 1/4W [M]	R509	ERDS2TJ103T	10K 1/4W [M]
R132	ERDS2TJ103T	10K 1/4W [M]	R367	ERDS2TJ102T	1K 1/4W [M]	R440	ERDS1FVJ560T	56 1/2W [M]	R510	ERDS2TJ103T	10K 1/4W [M]
R133	ERDS2TJ102T	1K 1/4W [M]	R368	ERDS2TJ102T	1K 1/4W [M]	R441	ERDS2TJ473T	47K 1/4W [M]	R511	ERDS2TJ471T	470 1/4W [M]
R134	ERDS2TJ102T	1K 1/4W [M]	R369	ERDS2TJ182T	1.8K 1/4W [M]	R442	ERDS2TJ473T	47K 1/4W [M]	R512	ERDS2TJ471T	470 1/4W [M]
R135	ERDS2TJ102T	1K 1/4W [M]	R370	ERDS2TJ182T	1.8K 1/4W [M]	R443	ERDS1FVJ560T	56 1/2W [M]	R513	ERDS2TJ474T	470K 1/4W [M]
			R371	ERD2FCVG220T	22 1/4W [M]	R451	ERDS2TJ224T	220K 1/4W [M]	R514	ERDS2TJ474T	470K 1/4W [M]
			R372	ERD2FCVG220T	22 1/4W [M]	R452	ERDS2TJ224T	220K 1/4W [M]	R515	ERDS2TJ474T	470K 1/4W [M]

Ref No.	Part No.	Values & Remarks	Ref No.	Part No.	Values & Remarks	Ref No.	Part No.	Values & Remarks	Ref No.	Part No.	Values & Remarks
R516	ERDS2TJ474T	470K 1/4W [M]	R574	ERDS2TJ223T	22K 1/4W [M]	R633	ERDS2TJ473T	47K 1/4W [M]	R697	ERDS2TJ221T	220 1/4W [M]
R517	ERDS2TJ182T	1.8K 1/4W [M]	R575	ERDS2TJ223T	22K 1/4W [M]	R634	ERDS2TJ474T	470K 1/4W [M]	R698	ERDS2TJ222T	2.2K 1/4W [M]
R518	ERDS2TJ182T	1.8K 1/4W [M]	R576	ERDS2TJ223T	22K 1/4W [M]	R635	ERDS2TJ154T	150K 1/4W [M]	R699	ERDS2TJ222T	2.2K 1/4W [M]
R519	ERDS2TJ332T	3.3K 1/4W [M]	R577	ERDS2TJ223T	22K 1/4W [M]	R636	ERDS2TJ473T	47K 1/4W [M]	R703	ERDS1FVJ3R9T	3.9 1/2W [M]
R520	ERDS2TJ332T	3.3K 1/4W [M]	R578	ERDS2TJ223T	22K 1/4W [M]	R637	ERDS2TJ154T	150K 1/4W [M]	R704	ERDS1FVJ3R9T	3.9 1/2W [M]
R521	ERDS2TJ223T	22K 1/4W [M]	R579	ERDS2TJ223T	22K 1/4W [M]	R638	ERDS2TJ154T	150K 1/4W [M]	R705	ERDS2TJ472T	4.7K 1/4W [M]
R522	ERDS2TJ223T	22K 1/4W [M]	R580	ERDS2TJ223T	22K 1/4W [M]	R639	ERDS2TJ104T	100K 1/4W [M]	R706	ERDS2TJ102T	1K 1/4W [M]
R523	ERDS2TJ392T	3.9K 1/4W [M]	R581	ERDS2TJ223T	22K 1/4W [M]	R640	ERDS2TJ681T	680 1/4W [M]	R707	ERD25FVJ221T	220 1/4W [M]
R524	ERDS2TJ392T	3.9K 1/4W [M]	R582	ERDS2TJ223T	22K 1/4W [M]	R641	ERDS2TJ472T	4.7K 1/4W [M]	R708	ERDS2TJ152T	1.5K 1/4W [M]
R525	ERDS2TJ222T	2.2K 1/4W [M]	R583	ERDS2TJ272T	2.7K 1/4W [M]	R642	ERDS2TJ182T	1.8K 1/4W [M]	R709	ERDS2TJ1R5T	1.5 1/4W [M]
R526	ERDS2TJ222T	2.2K 1/4W [M]	R584	ERDS2TJ272T	2.7K 1/4W [M]	R643	ERDS2TJ563T	56K 1/4W [M]	R710	ERDS2TJ1R5T	1.5 1/4W [M]
R527	ERDS2TJ122T	1.2K 1/4W [M]	R585	ERDS2TJ103T	10K 1/4W [M]	R644	ERDS1FVJ100T	10 1/2W [M]	R711	ERDS2TJ752T	7.5K 1/4W [M]
R528	ERDS2TJ122T	1.2K 1/4W [M]	R586	ERDS2TJ103T	10K 1/4W [M]	R645	ERDS2TJ470T	47 1/4W [M]	R712	ERDS2TJ682T	6.8K 1/4W [M]
R529	ERDS2TJ273T	27K 1/4W [M]	R595	ERDS2TJ102T	1K 1/4W [M]	R647	ERDS2TJ221T	220 1/4W [M]	R713	ERDS2TJ390T	39 1/4W [M]
R530	ERDS2TJ273T	27K 1/4W [M]	R596	ERDS2TJ102T	1K 1/4W [M]	R651	ERDS2TJ472T	4.7K 1/4W [M]	R714	ERDS2TJ390T	39 1/4W [M]
R531	ERDS2TJ332T	3.3K 1/4W [M]	R597	ERDS2TJ102T	1K 1/4W [M]	R652	ERDS2TJ472T	4.7K 1/4W [M]	R721	ERDS1FVJ561T	560 1/2W [M]
R532	ERDS2TJ332T	3.3K 1/4W [M]	R598	ERDS2TJ102T	1K 1/4W [M]	R653	ERDS2TJ182T	1.8K 1/4W [M]	R722	ERDS2TJ123T	12K 1/4W [M]
R533	ERDS2TJ473T	47K 1/4W [M]	R601	ERDS2TJ472T	4.7K 1/4W [M]	R654	ERDS2TJ182T	1.8K 1/4W [M]	R723	ERDS1FVJ100T	10 1/2W [M]
R534	ERDS2TJ473T	47K 1/4W [M]	R602	ERDS2TJ472T	4.7K 1/4W [M]	R655	ERDS2TJ221T	220 1/4W [M]	R724	ERDS1FVJ100T	10 1/2W [M]
R535	ERDS2TJ272T	2.7K 1/4W [M]	R603	ERDS2TJ182T	1.8K 1/4W [M]	R656	ERDS2TJ221T	220 1/4W [M]	R725	ERDS2TJ821T	820 1/4W [M]
R536	ERDS2TJ272T	2.7K 1/4W [M]	R604	ERDS2TJ182T	1.8K 1/4W [M]	R657	ERDS2TJ563T	56K 1/4W [M]	R726	ERD25FVJ331T	330 1/4W [M]
R537	ERDS2TJ103T	10K 1/4W [M]	R605	ERDS2TJ221T	220 1/4W [M]	R658	ERDS2TJ563T	56K 1/4W [M]	R727	ERD25FVJ331T	330 1/4W [M]
R538	ERDS2TJ103T	10K 1/4W [M]	R606	ERDS2TJ221T	220 1/4W [M]	R659	ERDS2TJ470T	47 1/4W [M]	R728	ERDS2TJ684T	680K 1/4W [M]
R543	ERDS2TJ102T	1K 1/4W [M]	R607	ERDS2TJ563T	56K 1/4W [M]	R660	ERDS2TJ470T	47 1/4W [M]	R729	ERDS2TJ684T	680K 1/4W [M]
R544	ERDS2TJ102T	1K 1/4W [M]	R608	ERDS2TJ563T	56K 1/4W [M]	R661	ERDS1FVJ100T	10 1/2W [M]	R730	ERDS1FVJ5R6T	5.6 1/2W [M]
R545	ERDS2TJ684T	680K 1/4W [M]	R609	ERDS2TJ470T	47 1/4W [M]	R662	ERDS1FVJ100T	10 1/2W [M]	R751	ERC12UGK335D	3.3M 1/2W[M](PC)
R546	ERDS2TJ332T	3.3K 1/4W [M]	R610	ERDS2TJ470T	47 1/4W [M]	R674	ERD25FVJ4R7T	4.7 1/4W [M]	R751	ERC12ZGK335D	3.3M 1/2W[M](P)
R550	ERDS2TJ332T	3.3K 1/4W [M]	R611	ERDS1FVJ100T	10 1/2W [M]	R675	ERDS2TJ222T	2.2K 1/4W [M]	R754	ERDS2TJ102T	1K 1/4W [M]
R551	ERDS2TJ102T	1K 1/4W [M]	R612	ERDS1FVJ100T	10 1/2W [M]	R676	ERDS2TJ222T	2.2K 1/4W [M]	R771	ERDS2TJ104T	100K 1/4W [M]
R552	ERDS2TJ102T	1K 1/4W [M]	R613	ERDS2TJ222T	2.2K 1/4W [M]	R677	ERDS2TJ222T	2.2K 1/4W [M]	R773	ERDS2TJ103T	10K 1/4W [M]
R553	ERDS2TJ104T	100K 1/4W [M]	R614	ERDS2TJ222T	2.2K 1/4W [M]	R678	ERDS2TJ222T	2.2K 1/4W [M]	R774	ERDS2TJ155T	1.5M 1/4W [M]
R554	ERDS2TJ104T	100K 1/4W [M]	R615	ERDS2TJ681T	680 1/4W [M]	R679	ERDS2TJ102T	1K 1/4W [M]	R775	ERDS2TJ331T	330 1/4W [M]
R555	ERDS2TJ223T	22K 1/4W [M]	R616	ERD25FVJ391T	390 1/4W [M]	R680	ERDS2TJ124T	120K 1/4W [M]	R776	ERDS1FVJ150T	15 1/2W [M]
R556	ERDS2TJ223T	22K 1/4W [M]	R617	ERD25FVJ391T	390 1/4W [M]	R681	ERDS2TJ154T	150K 1/4W [M]	R777	ERDS2TJ154T	150K 1/4W [M]
R557	ERDS2TJ821T	820 1/4W [M]	R618	ERD25FVJ391T	390 1/4W [M]	R682	ERDS2TJ184T	180K 1/4W [M]	R778	ERDS2TJ472T	4.7K 1/4W [M]
R558	ERDS2TJ821T	820 1/4W [M]	R619	ERD25FVJ391T	390 1/4W [M]	R683	ERDS2TJ473T	47K 1/4W [M]	R779	ERDS2TJ103T	10K 1/4W [M]
R561	ERDS2TJ102T	1K 1/4W [M]	R621	ERDS2TJ682T	6.8K 1/4W [M]	R684	ERDS2TJ474T	470K 1/4W [M]	R781	ERDS2TJ222T	2.2K 1/4W [M]
R562	ERDS2TJ102T	1K 1/4W [M]	R622	ERDS2TJ682T	6.8K 1/4W [M]	R685	ERDS2TJ154T	150K 1/4W [M]	R782	ERDS2TJ390T	39 1/4W [M]
R563	ERDS2TJ104T	100K 1/4W [M]	R623	ERDS2TJ682T	6.8K 1/4W [M]	R686	ERDS2TJ473T	47K 1/4W [M]	R784	ERDS2TJ154T	150K 1/4W [M]
R564	ERDS2TJ104T	100K 1/4W [M]	R624	ERD25FVJ4R7T	4.7 1/4W [M]	R687	ERDS2TJ154T	150K 1/4W [M]	R786	ERDS2TJ154T	150K 1/4W [M]
R565	ERDS2TJ223T	22K 1/4W [M]	R625	ERG1SJ101E	100 1W [M]	R688	ERDS2TJ154T	150K 1/4W [M]	R791	ERDS2TJ123T	12K 1/4W [M]
R566	ERDS2TJ154T	150K 1/4W [M]	R626	ERG1SJ101E	100 1W [M]	R689	ERDS2TJ821T	820 1/4W [M]	R792	ERDS2TJ123T	12K 1/4W [M]
R567	ERDS2TJ821T	820 1/4W [M]	R627	ERG1SJ101E	100 1W [M]	R690	ERDS2TJ821T	820 1/4W [M]	R793	ERDS2TJ123T	12K 1/4W [M]
R568	ERDS2TJ681T	680 1/4W [M]	R628	ERG1SJ101E	100 1W [M]	R691	ERDS2TJ472T	4.7K 1/4W [M]	R794	ERDS2TJ123T	12K 1/4W [M]
R569	ERDS2TJ104T	100K 1/4W [M]	R629	ERDS2TJ102T	1K 1/4W [M]	R692	ERDS2TJ182T	1.8K 1/4W [M]	R795	ERDS2TJ223T	22K 1/4W [M]
R571	ERDS2TJ223T	22K 1/4W [M]	R630	ERDS2TJ124T	120K 1/4W [M]	R693	ERDS2TJ563T	56K 1/4W [M]	R796	ERDS2TJ223T	22K 1/4W [M]
R572	ERDS2TJ223T	22K 1/4W [M]	R631	ERDS2TJ154T	150K 1/4W [M]	R694	ERDS1FVJ100T	10 1/2W [M]	R797	ERDS2TJ223T	22K 1/4W [M]
R573	ERDS2TJ223T	22K 1/4W [M]	R632	ERDS2TJ184T	180K 1/4W [M]	R695	ERDS2TJ470T	47 1/4W [M]	R798	ERDS2TJ223T	22K 1/4W [M]

Ref No.	Part No.	Values & Remarks	Ref No.	Part No.	Values & Remarks	Ref No.	Part No.	Values & Remarks	Ref No.	Part No.	Values & Remarks
R799	ERDS2TJ682T	6.8K 1/4W [M]	R981	ERDS2TJ122T	1.2K 1/4W [M]	R1685	ERDS2TJ270T	27 1/4W [M]	C123	ECEA1HKA010B	1 50V [M]
R891	ERDS2TJ103T	10K 1/4W [M]	R982	ERDS2TJ152T	1.5K 1/4W [M]	R1686	ERDS2TJ270T	27 1/4W [M]	C124	ECBT1H102KB5	1000P 50V [M]
R892	ERDS2TJ103T	10K 1/4W [M]	R983	ERDS2TJ182T	1.8K 1/4W [M]	R1687	ERDS2TJ270T	27 1/4W [M]	C125	ECBT1H150JC5	15P 50V [M]
R893	ERDS2TJ103T	10K 1/4W [M]	R984	ERDS2TJ222T	2.2K 1/4W [M]	R1688	ERDS2TJ270T	27 1/4W [M]	C126	ECBT1H104ZF5	0.1 50V [M]
R894	ERDS2TJ103T	10K 1/4W [M]	R985	ERDS2TJ332T	3.3K 1/4W [M]	R1689	ERDS2TJ270T	27 1/4W [M]	C127	ECEA1CKA220B	22 16V [M]
R901	ERDS2TJ102T	1K 1/4W [M]	R986	ERDS2TJ472T	4.7K 1/4W [M]	R1690	ERDS2TJ270T	27 1/4W [M]	C128	ECBT1C103NS5	0.01 16V [M]
R906	ERDS2TJ222T	2.2K 1/4W [M]	R990	ERDS2TJ153T	15K 1/4W [M]	R1691	ERDS2TJ270T	27 1/4W [M]	C129	ECEA0JKA101B	100 6.3V [M]
R907	ERDS2TJ104T	100K 1/4W [M]	R991	ERDS2TJ104T	100K 1/4W [M]	R1692	ERDS2TJ270T	27 1/4W [M]	C130	ECEA0JKA101B	100 6.3V [M]
R908	ERDS2TJ104T	100K 1/4W [M]	R992	ERDS2TJ104T	100K 1/4W [M]	R1693	ERDS2TJ270T	27 1/4W [M]	C131	ECBT1C103NS5	0.01 16V [M]
R909	ERDS2TJ104T	100K 1/4W [M]	R993	ERDS2TJ104T	100K 1/4W [M]	R1694	ERDS2TJ270T	27 1/4W [M]	C132	ECBT1H102KB5	1000P 50V [M]
R910	ERDS2TJ102T	1K 1/4W [M]	R994	ERDS2TJ104T	100K 1/4W [M]	R1695	ERDS2TJ102T	1K 1/4W [M]	C133	ECBT1H150JC5	15P 50V [M]
R911	ERDS2TJ104T	100K 1/4W [M]	R995	ERDS2TJ104T	100K 1/4W [M]	R1696	ERDS2TJ102T	1K 1/4W [M]	C134	ECBT1H180JC5	18P 50V [M]
R913	ERDS2TJ103T	10K 1/4W [M]	R996	ERDS2TJ104T	100K 1/4W [M]	R1699	ERDS2TJ332T	3.3K 1/4W [M]	C137	ECBT1H271KB5	270P 50V [M]
R915	ERDS2TJ222T	2.2K 1/4W [M]	R997	ERDS2TJ101T	100 1/4W [M]				C138	ECBT1H271KB5	270P 50V [M]
R917	ERDS2TJ103T	10K 1/4W [M]	R998	ERDS2TJ101T	100 1/4W [M]			CAPACITORS	C141	ECEA1HKA010B	1 50V [M]
R920	ERDS2TJ271T	270 1/4W [M]	R1001	ERDS2TJ102T	1K 1/4W [M]				C142	ECEA1HKA010B	1 50V [M]
R921	ERDS2TJ121T	120 1/4W [M]	R1002	ERDS2TJ102T	1K 1/4W [M]	C1	ECBT1H5R6KC5	5.6P 50V [M]	C143	ECEA1HKA010B	1 50V [M]
R922	ERDS2TJ472T	4.7K 1/4W [M]	R1003	ERDS2TJ102T	1K 1/4W [M]	C2	RCBS1H102KBY	1000P 50V [M]	C144	ECEA1HKA010B	1 50V [M]
R929	ERDS2TJ101T	100 1/4W [M]	R1004	ERDS2TJ102T	1K 1/4W [M]	C3	ECBT1H2R2KC5	2.2P 50V [M]	C145	ECBT1H220JC5	22P 50V [M]
R930	ERDS2TJ101T	100 1/4W [M]	R1005	ERDS2TJ203T	20K 1/4W [M]	C4	ECBT1H181KB5	180P 50V [M]	C146	ECBT1H331KB5	330P 50V [M]
R931	ERDS2TJ271T	270 1/4W [M]	R1007	ERDS2TJ473T	47K 1/4W [M]	C5	ECBT1H5R6KC5	5.6P 50V [M]	C147	ECBT1H102KB5	1000P 50V [M]
R932	ERDS2TJ271T	270 1/4W [M]	R1008	ERDS2TJ473T	47K 1/4W [M]	C6	ECBT1H3R3KC5	3.3P 50V [M]	C148	ECBT1C103NS5	0.01 16V [M]
R933	ERDS2TJ271T	270 1/4W [M]	R1009	ERDS2TJ332T	3.3K 1/4W [M]	C7	ECBT1H4R7KC5	4.7P 50V [M]	C149	ECBT1C103NS5	0.01 16V [M]
R934	ERDS2TJ271T	270 1/4W [M]	R1010	ERDS2TJ332T	3.3K 1/4W [M]	C8	ECBT1H3R3KC5	3.3P 50V [M]	C150	ECBT1H104ZF5	0.1 50V [M]
R935	ERDS2TJ271T	270 1/4W [M]	R1011	ERDS2TJ332T	3.3K 1/4W [M]	C9	ECBT1H2R2KC5	2.2P 50V [M]	C172	ECBT1H331KB5	330P 50V [M]
R936	ERDS2TJ271T	270 1/4W [M]	R1012	ERDS2TJ102T	1K 1/4W [M]	C10	ECBT1H180JC5	18P 50V [M]	C173	ECEA1CKA220B	22 16V [M]
R937	ERDS2TJ271T	270 1/4W [M]	R1013	ERDS2TJ103T	10K 1/4W [M]	C11	RCBS1H102KBY	1000P 50V [M]	C174	ECEA1CKA100B	10 16V [M]
R938	ERDS2TJ271T	270 1/4W [M]	R1014	ERDS2TJ104T	100K 1/4W [M]	C101	ECBT1C103NS5	0.01 16V [M]	C175	ECBT1C103NS5	0.01 16V [M]
R939	ERDS2TJ271T	270 1/4W [M]	R1015	ERD2FCVJ4R7T	4.7 1/4W [M]	C103	ECBT1C103NS5	0.01 16V [M]	C196	ECBT1H102KB5	1000P 50V [M]
R940	ERDS2TJ271T	270 1/4W [M]	R1051	ERDS2TJ393T	39K 1/4W [M]	C104	ECBT1H102KB5	1000P 50V [M]	C308	ECA0JM101B	01 6.3V [M]
R941	ERDS2TJ271T	270 1/4W [M]	R1052	ERDS2TJ105T	1M 1/4W [M]	C105	ECBT1H102KB5	1000P 50V [M]	C309	ECA0JM101B	01 6.3V [M]
R942	ERDS2TJ181T	180 1/4W [M]	R1053	ERDS2TJ102T	1K 1/4W [M]	C106	ECBT1C103NS5	0.01 16V [M]	C311	ECEA1EU4R7B	4.7 25V [M]
R943	ERDS2TJ102T	1K 1/4W [M]	R1055	ERDS2TJ224T	220K 1/4W [M]	C107	ECBT1H473ZF5	0.047 50V [M]	C312	ECEA1EU4R7B	4.7 25V [M]
R944	ERDS2TJ104T	100K 1/4W [M]	R1056	ERDS2TJ153T	15K 1/4W [M]	C108	ECBT1H8R2KC5	8.2P 50V [M]	C329	ECBT1H470J5	47P 50V [M]
R945	ERDS2TJ104T	100K 1/4W [M]	R1061	ERDS2TJ222T	2.2K 1/4W [M]	C109	ECBT1C103NS5	0.01 16V [M]	C330	ECBT1H470J5	47P 50V [M]
R946	ERDS2TJ103T	10K 1/4W [M]	R1062	ERDS2TJ273T	27K 1/4W [M]	C110	ECBT1C103NS5	0.01 16V [M]	C351	ECEA0JKA101B	100 6.3V [M]
R948	ERDS2TJ103T	10K 1/4W [M]	R1063	ERDS2TJ332T	3.3K 1/4W [M]	C111	ECEA1EKA4R7B	4.7 25V [M]	C352	ECEA0JKA101B	100 6.3V [M]
R949	ERDS2TJ103T	10K 1/4W [M]	R1151	ERDS2TJ473T	47K 1/4W [M]	C112	ECBT1C103NS5	0.01 16V [M]	C354	ECBT1H104ZF5	0.1 50V [M]
R950	ERDS2TJ102T	1K 1/4W [M]	R1152	ERDS2TJ473T	47K 1/4W [M]	C113	ECBT1H102KB5	1000P 50V [M]	C355	ECBT1H104ZF5	0.1 50V [M]
R951	ERDS2TJ122T	1.2K 1/4W [M]	R1154	ERDS2TJ333T	33K 1/4W [M]	C114	ECEA1HKA3R3B	3.3 50V [M]	C357	ECBT1E103ZF5	0.01 25V [M]
R952	ERDS2TJ152T	1.5K 1/4W [M]	R1155	ERDS2TJ393T	39K 1/4W [M]	C115	ECEA1EKA4R7B	4.7 25V [M]	C358	ECBT1E103ZF5	0.01 25V [M]
R953	ERDS2TJ182T	1.8K 1/4W [M]	R1156	ERDS2TJ393T	39K 1/4W [M]	C116	ECBT1C822MS5	8200P 16V [M]	C373	ECEA1CKA470B	47 16V [M]
R954	ERDS2TJ222T	2.2K 1/4W [M]	R1158	ERDS2TJ104T	100K 1/4W [M]	C117	ECQB1H821JM3	820P 50V [M]	C374	ECEA1CKA470B	47 16V [M]
R955	ERDS2TJ332T	3.3K 1/4W [M]	R1160	ERDS2TJ104T	100K 1/4W [M]	C118	ECFR1E183KR	0.018 25V [M]	C375	ECEA1CKA470B	47 16V [M]
R956	ERDS2TJ472T	4.7K 1/4W [M]	R1681	ERDS2TJ270T	27 1/4W [M]	C119	ECFR1E183KR	0.018 25V [M]	C381	ECEA1HKA3R3B	3.3 50V [M]
R957	ERDS2TJ682T	6.8K 1/4W [M]	R1682	ERDS2TJ270T	27 1/4W [M]	C120	ECEA1HKA010B	1 50V [M]	C382	ECEA1HKA3R3B	3.3 50V [M]
R958	ERDS2TJ123T	12K 1/4W [M]	R1683	ERDS2TJ270T	27 1/4W [M]	C121	ECEA1HKA010B	1 50V [M]	C383	ECEA1HKA3R3B	3.3 50V [M]
R980	ERDS2TJ102T	1K 1/4W [M]	R1684	ERDS2TJ270T	27 1/4W [M]	C122	ECEA1HKA2R2B	2.2 50V [M]	C384	ECEA1HKA3R3B	3.3 50V [M]

Ref No.	Part No.	Values & Remarks	Ref No.	Part No.	Values & Remarks	Ref No.	Part No.	Values & Remarks	Ref No.	Part No.	Values & Remarks
C385	ECEA1HKA3R3B	3.3 50V [M]	C503	ECEA0JKA101B	100 6.3V [M]	C567	ECBT1E103ZF5	0.01 25V [M]	C667	ECEA2AN2R2SB	2.2 100V [M]
C386	ECEA1HKA3R3B	3.3 50V [M]	C504	ECEA0JKA101B	100 6.3V [M]	C568	ECBT1E103ZF5	0.01 25V [M]	C668	ECBT1H102KB5	1000P 50V [M]
C387	ECEA1HKA3R3B	3.3 50V [M]	C505	ECFR1C104MR	0.1 16V [M]	C569	ECEA1HKA010B	1 50V [M]	C669	ECA1EM101B	100 25V [M]
C388	ECEA1HKA3R3B	3.3 50V [M]	C506	ECFR1C104MR	0.1 16V [M]	C571	ECEA1VKA100B	10 35V [M]	C671	ECEA2AU100B	10 100V [M]
C401	ECEA1VKA4R7B	4.7 35V [M]	C511	ECEA1HKA3R3B	3.3 50V [M]	C572	ECEA1VKA100B	10 35V [M]	C691	ECA1JM330B	33 6.3V [M]
C402	ECEA1VKA4R7B	4.7 35V [M]	C512	ECEA1HKA3R3B	3.3 50V [M]	C573	ECBT1H680J5	68P 50V [M]	C692	ECBT1H821KB5	820P 50V [M]
C403	ECBT1E103ZF5	0.01 25V [M]	C513	ECBT1H150J5	15P 50V [M]	C574	ECBT1H680J5	68P 50V [M]	C693	ECCR1H180KC5	18P 50V [M]
C404	ECBT1E103ZF5	0.01 25V [M]	C514	ECBT1H150J5	15P 50V [M]	C575	ECEA1VKA100B	10 35V [M]	C694	ECQV1H473JZ3	0.047 50V [M]
C405	ECBT1H101KB5	100P 50V [M]	C515	ECBT1H221KB5	220P 50V [M]	C576	ECBT1H680J5	68P 50V [M]	C696	ECQE2104KF3	0.1 250V [M]
C406	ECBT1H101KB5	100P 50V [M]	C516	ECBT1H221KB5	220P 50V [M]	C577	ECEA1VKA100B	10 35V [M]	C701	ECBT1E103ZF5	0.01 25V [M]
C409	ECA1EM220B	22 25V [M]	C517	ECBT1H330J5	33P 50V [M]	C578	ECBT1H680J5	68P 50V [M]	C702	ECQE2104KF3	0.1 250V [M]
C410	ECA1EM220B	22 25V [M]	C518	ECBT1H330J5	33P 50V [M]	C579	ECEA1VKA100B	10 35V [M]	C703	ECE575V752UM	7500 75V [M]
C411	ECBT1H101KB5	100P 50V [M]	C519	ECEA1VKA4R7B	4.7 35V [M]	C580	ECEA1VKA100B	10 35V [M]	C704	ECE575V752UM	7500 75V [M]
C412	ECBT1H101KB5	100P 50V [M]	C520	ECEA1VKA4R7B	4.7 35V [M]	C581	ECBT1H680J5	68P 50V [M]	C705	EC0S1VP562BB	5600P 35V [M]
C413	ECA1CM100B	10 16V [M]	C521	ECEA1VKA4R7B	4.7 35V [M]	C582	ECBT1H680J5	68P 50V [M]	C706	EC0S1VP562BB	5600P 35V [M]
C414	ECA1CM100B	10 16V [M]	C522	ECEA1VKA4R7B	4.7 35V [M]	C585	ECEA1CKA100B	10 16V [M]	C707	ECA1VM101B	100 35V [M]
C415	ECBT1E103ZF5	0.01 25V [M]	C523	ECFR1E123KR	0.012 25V [M]	C586	ECEA1CKA100B	10 16V [M]	C708	ECKR1H103ZF5	0.01 50V [M]
C416	ECBT1E103ZF5	0.01 25V [M]	C524	ECFR1E123KR	0.012 25V [M]	C601	ECA1JM330B	33 6.3V [M]	C709	ECEA1CKA330B	33 16V [M]
C429	ECBT1H101KB5	100P 50V [M]	C525	ECQV1H683JM3	0.068 50V [M]	C602	ECA1JM330B	33 6.3V [M]	C710	ECBT1E103ZF5	0.01 25V [M]
C430	ECBT1H101KB5	100P 50V [M]	C526	ECQV1H683JM3	0.068 50V [M]	C603	ECBT1H821KB5	820P 50V [M]	C711	ECKR1H103ZF5	0.01 50V [M]
C431	ECA1CM100B	10 16V [M]	C527	ECBT1C562KR5	5600P 16V [M]	C604	ECBT1H821KB5	820P 50V [M]	C712	ECEA1HKA100B	10 50V [M]
C432	ECA1CM100B	10 16V [M]	C528	ECBT1C562KR5	5600P 16V [M]	C607	ECCR1H180KC5	18P 50V [M]	C713	ECKR1H103ZF5	0.01 50V [M]
C440	ECBT1E103ZF5	0.01 25V [M]	C529	ECQB1H273JM3	0.027 50V [M]	C608	ECCR1H180KC5	18P 50V [M]	C714	ECEA1EKA470B	47 25V [M]
C441	ECEA1HKN3R3B	3.3 50V [M]	C530	ECQB1H273JM3	0.027 50V [M]	C611	ECQV1H473JZ3	0.047 50V [M]	C715	ECEA1CKA101B	100 16V [M]
C451	ECEA1VKA4R7B	4.7 35V [M]	C531	ECBT1E103ZF5	0.01 25V [M]	C612	ECQV1H473JZ3	0.047 50V [M]	C721	ECQE2104KF3	0.1 250V [M]
C452	ECEA1VKA4R7B	4.7 35V [M]	C532	ECBT1E103ZF5	0.01 25V [M]	C615	ECBT1H103KB5	0.01 50V [M]	C751	ECKWRS102MBC	1000P 400V [M]▲
C453	ECBT1H101KB5	100P 50V [M]	C533	ECEA1CKA100B	10 16V [M]	C616	ECA1JM330B	33 6.3V [M]	C752	ECKR1H103ZF5	0.01 50V [M]▲
C454	ECBT1H101KB5	100P 50V [M]	C534	ECEA1CKA100B	10 16V [M]	C617	ECEA2AN2R2SB	2.2 100V [M]	C753	ECA1EM102EV	1000 25V [M]
C455	ECBT1H102KB5	1000P 50V [M]	C535	ECBT1H104ZF5	0.1 50V [M]	C618	ECBT1H102KB5	1000P 50V [M]	C754	ECBT1E103ZF5	0.01 25V [M]
C456	ECBT1H102KB5	1000P 50V [M]	C536	ECBT1H104ZF5	0.1 50V [M]	C619	ECA1EM101B	100 25V [M]	C755	ECA1CM470B	47 16V [M]
C457	ECEA1AKA330B	33 10V [M]	C537	ECEA1CKA100B	10 16V [M]	C621	ECEA2AU100B	10 100V [M]	C757	ECA1CM100B	10 16V [M]
C458	ECEA1AKA330B	33 10V [M]	C538	ECEA1CKA100B	10 16V [M]	C625	ECEA1HN100SB	10 50V [M]	C758	ECEA1AKA101B	100 10V [M]
C459	ECFR1E223KR	0.022 25V [M]	C551	ECEA1HKA3R3B	3.3 50V [M]	C626	ECEA1HN100SB	10 50V [M]	C771	ECEA1HKA4R7B	4.7 50V [M]
C460	ECFR1E223KR	0.022 25V [M]	C552	ECEA1HKA3R3B	3.3 50V [M]	C641	ECA1JM330B	33 6.3V [M]	C772	ECEA1HKA4R7B	4.7 50V [M]
C461	ECFR1E682KR	6800P 25V [M]	C553	ECBT1H101KB5	100P 50V [M]	C642	ECBT1H821KB5	820P 50V [M]	C773	ECBT1E223ZF5	0.022 25V [M]
C462	ECFR1E682KR	6800P 25V [M]	C554	ECBT1H101KB5	100P 50V [M]	C643	ECCR1H180KC5	18P 50V [M]	C774	ECEA0JKA101B	100 6.3V [M]
C463	ECEA1VKA4R7B	4.7 35V [M]	C555	ECBT1H221KB5	220P 50V [M]	C644	ECQV1H473JZ3	0.047 50V [M]	C775	ECEA1CKA100B	10 16V [M]
C464	ECEA1VKA4R7B	4.7 35V [M]	C556	ECBT1H221KB5	220P 50V [M]	C646	ECQE2104KF3	0.1 250V [M]	C776	ECEA1HKA010B	1 50V [M]
C465	ECBT1E103ZF5	0.01 25V [M]	C557	ECBT1E103ZF5	0.01 25V [M]	C651	ECA1JM330B	33 6.3V [M]	C891	ECEA1CKA100B	10 16V [M]
C466	ECBT1E103ZF5	0.01 25V [M]	C558	ECBT1E103ZF5	0.01 25V [M]	C652	ECA1JM330B	33 6.3V [M]	C894	ECBT1H101KB5	100P 50V [M]
C471	ECEA1VKA4R7B	4.7 35V [M]	C559	ECEA1CKA100B	10 16V [M]	C653	ECBT1H821KB5	820P 50V [M]	C895	ECBT1H101KB5	100P 50V [M]
C472	ECEA1VKA4R7B	4.7 35V [M]	C560	ECEA1CKA100B	10 16V [M]	C654	ECBT1H821KB5	820P 50V [M]	C901	ECEA0JU102B	1000 6.3V [M]
C473	ECBT1E103ZF5	0.01 25V [M]	C561	ECEA1HKA3R3B	3.3 50V [M]	C657	ECCR1H180KC5	18P 50V [M]	C902	ECBT1H104ZF5	0.1 50V [M]
C474	ECBT1E103ZF5	0.01 25V [M]	C562	ECEA1HKA3R3B	3.3 50V [M]	C658	ECCR1H180KC5	18P 50V [M]	C903	ECBT1E103ZF5	0.01 25V [M]
C475	ECBT1H101KB5	100P 50V [M]	C563	ECBT1H101KB5	100P 50V [M]	C661	ECQV1H473JZ3	0.047 50V [M]	C904	ECEA0JU102B	1000 6.3V [M]
C482	ECEA1HKA3R3B	3.3 50V [M]	C564	ECBT1H101KB5	100P 50V [M]	C662	ECQV1H473JZ3	0.047 50V [M]	C905	ECBT1E103ZF5	0.01 25V [M]
C501	ECFR1E333KR	0.033 25V [M]	C565	ECBT1H221KB5	220P 50V [M]	C665	ECBT1H103KB5	0.01 50V [M]	C906	ECEA0JKA101B	100 6.3V [M]
C502	ECFR1E333KR	0.033 25V [M]	C566	ECBT1H221KB5	220P 50V [M]	C666	ECA1JM330B	33 6.3V [M]	C908	ECBT1E103ZF5	0.01 25V [M]

Ref No.	Part No.	Values & Remarks	Ref No.	Part No.	Values & Remarks	Ref No.	Part No.	Values & Remarks	Ref No.	Part No.	Values & Remarks
C909	ECEA1VKA220B	22 35V [M]	C995	ECBT1H101KB5	100P 50V [M]	C1022	ECEA1HKA3R3B	3.3 50V [M]	C1055	ECEA1HKAR47B	0.47 50V [M]
C910	ECEA1VKA220B	22 35V [M]	C996	ECBT1H101KB5	100P 50V [M]	C1023	ECQV1H154JM3	0.15 50V [M]	C1056	ECFR1E823KR	0.082 25V [M]
C911	ECEA1VKA220B	22 35V [M]	C997	ECEA1CKA100B	10 16V [M]	C1024	ECQV1H154JM3	0.15 50V [M]	C1057	ECFR1E332KR	3300P 25V [M]
C912	ECEA1VKA220B	22 35V [M]	C998	ECBT1E103ZF5	0.01 25V [M]	C1025	ECEA1HKA3R3B	3.3 50V [M]	C1058	ECFR1E823KR	0.082 25V [M]
C913	ECEA1VKA100B	10 35V [M]	C1001	ECEA1HKA010B	1 50V [M]	C1026	ECEA1HKAR15B	0.15 50V [M]	C1059	ECEA1CKA101B	100 16V [M]
C914	ECEA1VKA100B	10 35V [M]	C1002	ECEA1HKA010B	1 50V [M]	C1027	ECEA1HKA4R7B	4.7 50V [M]	C1060	ECBT1E223ZF5	0.022 25V [M]
C916	ECEA1HKA010B	1 50V [M]	C1003	ECEA1HKA3R3B	3.3 50V [M]	C1028	ECEA1HKAR47B	0.47 50V [M]	C1062	ECBT1E223ZF5	0.022 25V [M]
C920	ECEA1HKA010B	1 50V [M]	C1004	ECEA1HKA3R3B	3.3 50V [M]	C1029	ECEA1HKA4R7B	4.7 50V [M]	C1063	ECEA1CKA101B	100 16V [M]
C921	ECBT1H331KB5	330P 50V [M]	C1005	ECEA1HKA010B	1 50V [M]	C1030	ECEA1HKAR47B	0.47 50V [M]	C1064	ECEA1HKA010B	1 50V [M]
C922	ECBT1H331KB5	330P 50V [M]	C1007	ECFR1E223KR	0.022 25V [M]	C1031	ECQV1H104JM3	0.1 50V [M]	C1065	ECBT1H681KB5	680P 50V [M]
C923	ECBT1H331KB5	330P 50V [M]	C1008	ECFR1E473KR	0.047 25V [M]	C1032	ECQV1H104JM3	0.1 50V [M]	C1067	ECBT1C152KR5	1500P 16V [M]
C924	ECBT1H331KB5	330P 50V [M]	C1009	ECEA0JU221B	220 6.3V [M]	C1033	ECEA0JKA470B	47 6.3V [M]	C1068	ECBT1C152KR5	1500P 16V [M]
C925	ECBT1H331KB5	330P 50V [M]	C1010	ECEA1CKA100B	10 16V [M]	C1034	ECQV1H474JM3	0.47 50V [M]	C1151	ECEA1HKA010B	1 50V [M]
C926	ECBT1H331KB5	330P 50V [M]	C1011	ECEA1CKA100B	10 16V [M]	C1035	ECBT1H681KB5	680P 50V [M]	C1152	ECFR1C683KR	0.068 16V [M]
C927	ECBT1H331KB5	330P 50V [M]	C1012	ECEA1CKA100B	10 16V [M]	C1036	ECBT1H101KB5	100P 50V [M]	C1153	ECFR1C273KR	0.027 16V [M]
C928	ECBT1H331KB5	330P 50V [M]	C1013	ECEA1CKA100B	10 16V [M]	C1037	ECBT1H101KB5	100P 50V [M]	C1154	ECEA1VKA4R7B	4.7 35V [M]
C929	ECBT1H331KB5	330P 50V [M]	C1014	ECEA0JU221B	220 6.3V [M]	C1038	ECBT1H101KB5	100P 50V [M]	C1156	ECBT1E103ZF5	0.01 25V [M]
C930	ECBT1H331KB5	330P 50V [M]	C1015	ECQV1H104JM3	0.1 50V [M]	C1039	ECEA1CU101B	100 16V [M]	C1157	ECBT1E103ZF5	0.01 25V [M]
C932	ECBT1H101KB5	100P 50V [M]	C1016	ECQV1H104JM3	0.1 50V [M]	C1040	ECEA1CKA100B	10 16V [M]	C1159	ECEA1HKA010B	1 50V [M]
C933	ECBT1H101KB5	100P 50V [M]	C1017	ECEA1HKAR47B	0.47 50V [M]	C1041	ECBT1E103ZF5	0.01 25V [M]	C1161	ECBT1H101KB5	100P 50V [M]
C991	ECBT1H101KB5	100P 50V [M]	C1018	ECEA1HKA4R7B	4.7 50V [M]	C1051	ECEA1HKA2R2B	2.2 50V [M]	C1685	ECBT1E103ZF5	0.01 25V [M]
C992	ECBT1H101KB5	100P 50V [M]	C1019	ECEA1HKAR47B	0.47 50V [M]	C1052	ECEA1HKAR33B	0.33 50V [M]			
C993	ECBT1H101KB5	100P 50V [M]	C1020	ECEA1HKA4R7B	4.7 50V [M]	C1053	ECEA1HKA3R3B	3.3 50V [M]			
C994	ECBT1H101KB5	100P 50V [M]	C1021	ECEA1HKAR15B	0.15 50V [M]	C1054	ECEA0JU221B	220 6.3V [M]			

ACCESSORY BOX

A1 (RAK-SA937MK)	: REMOTE CONTROL
A2 (RSA0010)	: AM LOOP ANT UNIT
A3 (SJA172)	: AC CORD
A4 (RSA0006)	: FM ANTENNA
A5 (RQT4208-P)	: O/I BOOK
A5 (RQT4167-P)	: O/I BOOK FOR REMOTE
A5 (RQT4210-C...PC)	: O/I BOOK
A5 (RQT4169-C...PC)	: O/I BOOK FOR REMOTE

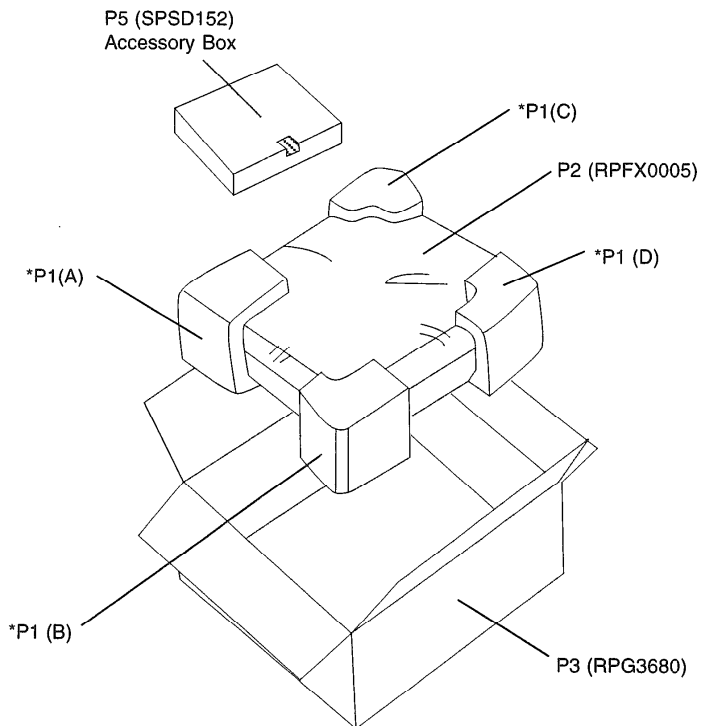
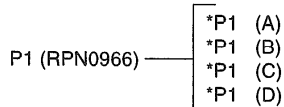

MESA Printed in Singapore
G980101900 S/N/J/L