

Service Manual

Tuner Amplifier

Tuner Amplifier

SA-CH750

• For (E), (EB), (EG) areas

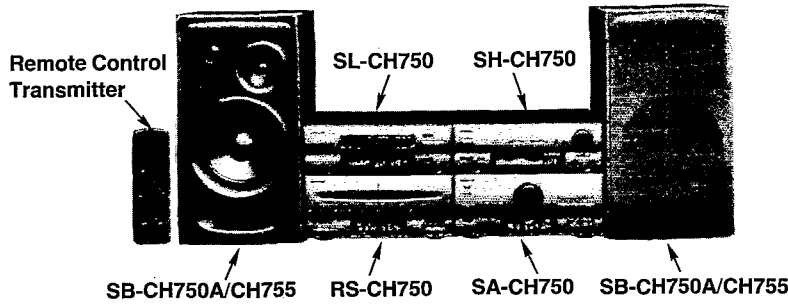

Colour

(K) Black Type

Areas

Suffix for Model No.	Area	Colour
(E)	Europe	(K)
(EB)	Great Britain	
(EG)	Germany and Italy	
(GC)	Asia, Latin America, Middle Near East and Africa	
(GN)	Oceania	

System: SC-CH750

Because of unique interconnecting cables, when a component requires service, send or bring in the entire system.

• For (GC), (GN) areas

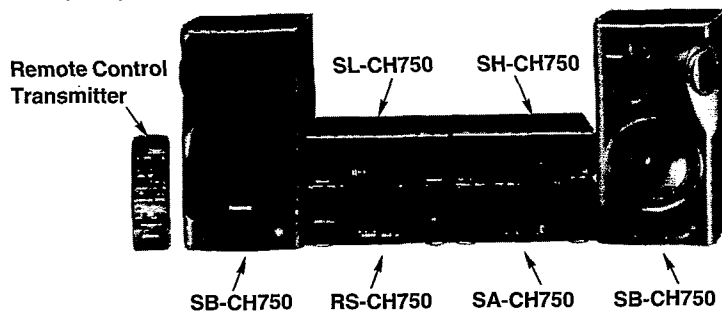

SPECIFICATIONS

(DIN 45 500)

■ Main Amp. Section

Power output	
DIN 1 kHz THD 1%	
both channel driven	2×50 W (6Ω)
For (GC), (GN) areas	
SFP, mode 1 kHz THD 1%	
MAIN	2×45 W (6Ω)
SURROUND	2×5 W (8Ω)
Total harmonic distortion	
Rated power at 1 kHz	1% (6Ω)
Half power at 1 kHz	0.09% (6Ω)
Load impedance	
MAIN	6–8Ω
SURROUND	8Ω
S/N (rated power)	84 dB
Frequency response	40 Hz–30 kHz (–3 dB)

■ FM Tuner Section

Frequency range	87.50 MHz–108.00 MHz (0.05 MHz steps)
Sensitivity	1.8 μV (IHF, usable)
S/N 26 dB	1.5 μV (75Ω)
S/N	
MONO	70 dB (75 dB, IHF)
Stereo separation at 1 kHz	35 dB
Antenna terminal(s)	75Ω (unbalanced)

■ AM TUNER SECTION

Frequency range	
MW	
For (E), (EB), (EG), (GN) areas	522–1611 kHz (9 kHz steps)
	530–1620 kHz (10 kHz steps)
For (GC) area	531–1602 kHz (9 kHz steps)
	530–1600 kHz (10 kHz steps)
LW	
For (E), (EB), (EG), (GN), areas	144–288 kHz (9 kHz steps)
For (GC) area	153–279 kHz (9 kHz steps)
Sensitivity (S/N 20 dB)	
MW	500 μV/m
LW	50 μV

■ Timer Section

Clock	Quartz-lock type
Function	24-hour programmable; Play timer (1 time)
	Rec timer (1 time)
	Sleep (120 min. 1 min. intervals)
Setting	1 minute–23 hours 59 minutes (1 min. intervals)

System	Sound processor	Tuner amplifier	Compact disc player	Cassette deck	Speakers
SC-CH750	SH-CH750	SA-CH750	SL-CH750	RS-CH750	*SB-CH750A (E), (EB), (EG) areas *SB-CH755 Switzerland only SB-CH750 (GC), (GN) areas

*Made in PAES

■ GENERAL

Power consumption	175 W
Power supply	
For (E), (EG) areas	AC 50/60 Hz, 230 V
For (EB), (GN) areas	AC 50/60 Hz, 230 V~240 V
For (GC) area	AC 50/60 Hz, 110/127/220/240 V

Dimension (W×H×D)
Weight

270×119×334 mm
5.5 kg

Notes:

1. Specifications are subject to change without notice.
2. Weight and dimensions are approximate.
3. Total harmonic distortion is measured by the digital spectrum analyzer.

■ CONTENTS

	Page
●BEFORE REPAIR	2
●PROTECTION CIRCUITRY	2
●ACCESSORIES	2, 3
●LOCATION OF CONTROLS	3, 4
●STACKING THE COMPONENTS	5
●CONNECTIONS	6~9
●SETTING THE TIME OF DAY	9
●DISASSEMBLY INSTRUCTIONS	10~13

	Page
●SCHEMATIC DIAGRAM	14~22
●PRINTED CIRCUIT BOARD DIAGRAM	23~27
●WIRING CONNECTION DIAGRAM	28
●BLOCK DIAGRAM	29~31
●FUNCTION OF IC TERMINALS	32
●REPLACEMENT PARTS LIST	33~38
●CABINET PARTS LOCATION	39
●PACKAGING	40

■ BEFORE REPAIR

- (1) Turn off the power supply. Using a 10Ω, 10 W resistor, connect both ends of power supply capacitors (C701, C702) in order to discharge the voltage.
- (2) Before turning the power supply on, after completion of repair, slowly apply the primary voltage by using a power supply voltage controller to make sure that the consumed current at 50/60 Hz in NO SIGNAL mode is mode should be shown below with respect to supply voltage 230 V/240 V.

Power supply voltage	AC 230 V	AC 240 V
Consumed current 50 Hz	130~230 mA	110~210 mA

■ PROTECTION CIRCUITRY

The protection circuitry may have operated if either of the following conditions is noticed:

- *No sound is heard when the power is switched ON.
- *Sound stops during a performance.

The functions of this circuitry is to prevent circuitry damage if, for example, the positive and negative speaker connection wires are "shorted", or if speaker systems with an impedance less than the indicated rated impedance of this unit are used.

If this occurs, follow the procedure outlined below:

1. Switch OFF the power.
2. Determine the cause of the problem and correct it.
3. Switch ON the power once again.

Note:

When the protection circuitry functions, the unit will not operate unless the power is first switched OFF and then ON again.

■ ACCESSORIES

Check the packing carton for these accessories.

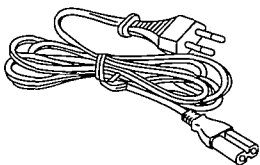

(RJA0019-2K) for (E), (EG), (GC) areas
(VJA0733) for (EB) area
(SJA173) for (GN) area

- AC power supply cord 1 pc.

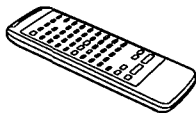

(RAK-SC709WH)

- Remote control transmitter 1 pc.

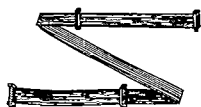

(REX0462)

- Flat cable 1 pc.

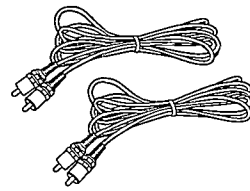

- Surround speaker cords 2 pcs.
(RJL1P001B25) for (GC), (GN) areas

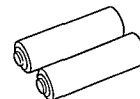

Note: These are available on sale route.

- Remote control batteries
UM-4, AAA, R03 2 pcs.



(SMA233-1M)

- Antenna holder 1 pc.

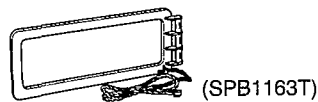

- LW/MW loop antenna 1 pc.

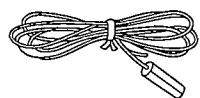

- FM indoor antenna 1 pc.

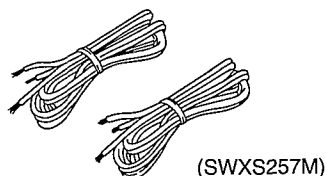

- Speaker cords 2 pcs.

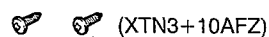

- Mounting screws 2 pcs.



- Attachment plug 1 pc.
(SJP9009) for (EB) area



- Power plug adaptor 1 pc.
(SJP5213-2) for (GC) area

Note:

The configurations of AC power supply cord and FM indoor antenna differ according to area.

LOCATION OF CONTROLS

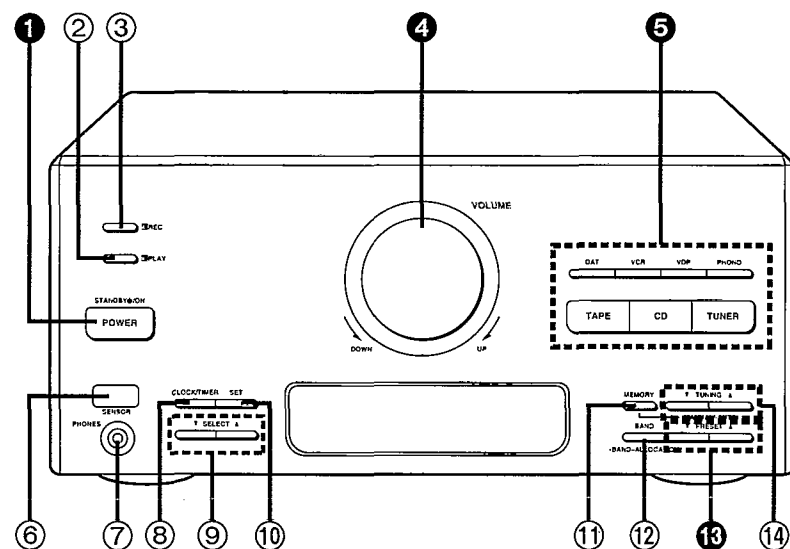

1 Power "STANDBY O /ON" switch (POWER, STANDBY O /ON)

This switch switches ON and OFF the secondary circuit power only. The unit is in the "standby" condition when this switch is set to the STANDBY O position. Regardless of the switch setting, the primary circuit is always "live" as long as the power cord is connected to an electrical outlet.

2 Timer play button (O PLAY)

Press to confirm, exit or reset the play timer.

3 Timer recording button (O REC)

Press to confirm, exit or reset the record timer.

4 Volume level control (VOLUME)

Turn to adjust the volume level.

Note that --- dB is the lowest volume setting and 0 dB is the highest.

5 Input select buttons (TAPE, CD, TUNER, DAT, VCR, VDP, PHONO)

Press to select the sound source.

6 Remote control signal sensor (SENSOR)

Receives the signals from the remote control.

7 Headphones jack (PHONES) (O 3.5, 32 Ω)

Plug headphones cord into this jack.

8 Clock/timer button (CLOCK/TIMER)

Press to select the clock set mode or desired timer mode.

9 Timer select buttons (\blacktriangledown SELECT \blacktriangle)

Use when setting the current time and timer.

10 Setting button (SET)

Press to set the present time in the clock mode, or set the various selection in the timer mode.

11 Preset memory button (MEMORY, -MANUAL, -AUTO)

Press to put a broadcast station into the memory.

12 Band select/allocation change button (BAND, -BAND -ALLOCATION)

Press to select the MW, LW or FM radio band. Press and hold to change the MW frequency step.

13 Preset tuning buttons (\blacktriangledown PRESET \blacktriangle)

Use to select channel number for a broadcast station which has been stored in the tuner's memory.

14 Tuning buttons (\blacktriangledown TUNING \blacktriangle)

Use to tune in a desired broadcast station.

The functions indicated by the numbers with black background (for example 1) can also be activated from the remote control.

Display section

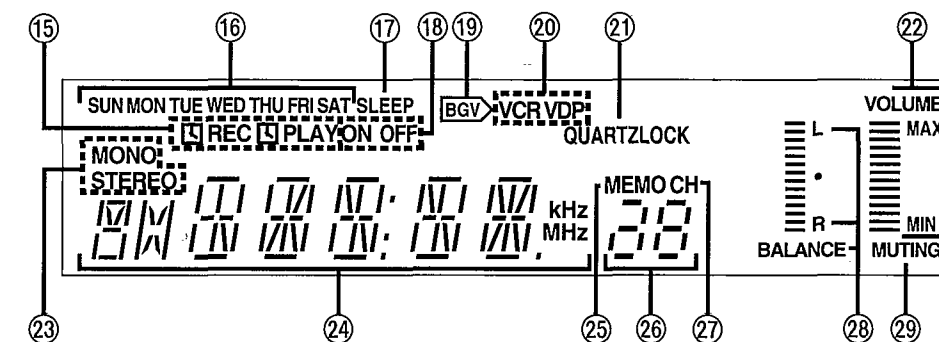

15 Timer mode indicators (O REC, O PLAY)

O REC: Lights when you have set the record timer mode.
 O PLAY: Lights when you have set the play timer mode.

16 Day indicators (SUN-SAT)

Shows the day of the week or the day the timer has been set for.

17 Sleep timer indicator (SLEEP)

Lights when you have set the sleep timer mode.

18 Timer on/off indicator (ON, OFF)

Lights together with the setting time to show the timer ON time and OFF time.

19 BGV (background visual) indicator (O BGV O)

Lights when listening to audio sound source.

20 Visual source indicators (VCR, VDP)

Lights to show it is possible to enjoy BGV (Back Ground Visual) if you connect video deck or video disc player to this system.

21 Quartz lock indicator (QUARTZLOCK)

Lights when you precisely tune in a broadcast station.

22 Volume level display (VOLUME, MAX, MIN)

Shows the volume level.

23 FM STEREO/MONO indicator (MONO, STEREO)

"STEREO" lights when an FM stereo broadcast is being received. If you press FM mode button on the remote control to select monaural mode, "MONO" lights.

24 Alpha-numeric display

Shows the selected source, present time, and the contents of the timer setting, received frequencies, volume level.

25 Memory indicator (MEMO)

Lights when the preset memory button is pressed.

26 Preset channel display

Shows the preset channel you select.

27 Channel indicator (CH)

Lights when the unit is in the preset tuning mode.

28 Balance display (L, R, BALANCE)

Shows the left-right volume balance.

29 Muting indicator (MUTING)

Lights when you activate the muting mode.

■ STACKING THE COMPONENTS

Install the various components as shown below.

■ Horizontal stacking

For (E), (EB), (EG) areas

Place both speakers so that the tweeter comes outward.

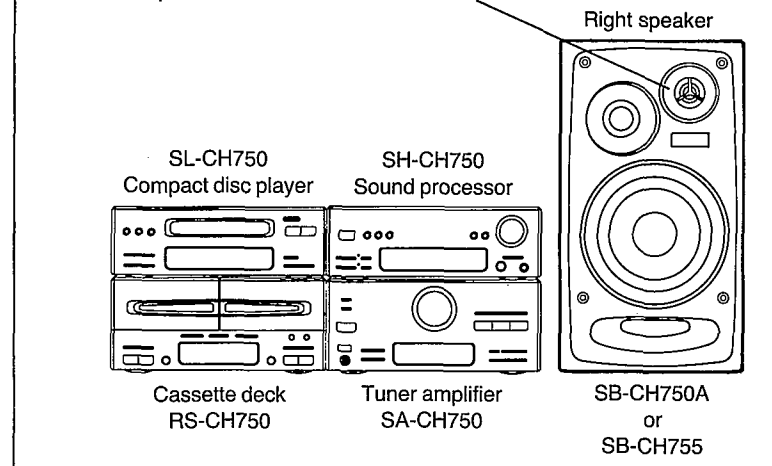

For (GC), (GN) areas

Place both speaker so that the surround speaker comes outward.

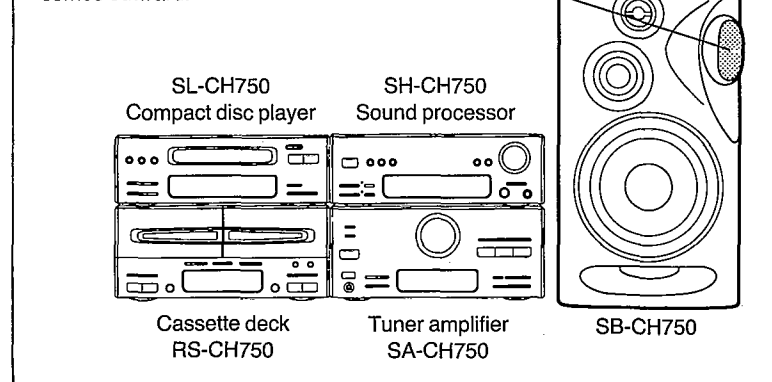

■ System layout

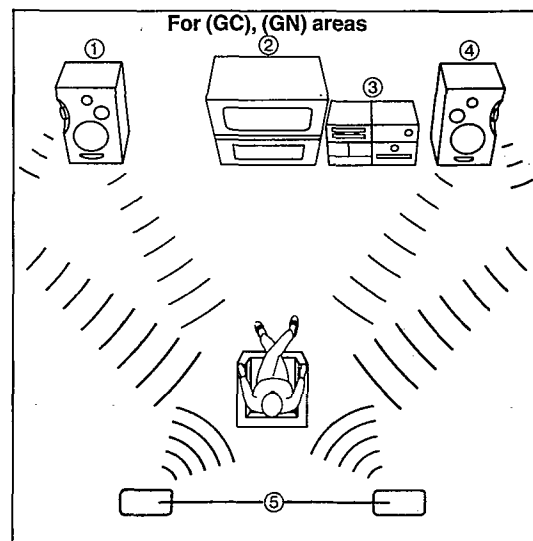

To produce a better stereo sound, install both speakers away from the system.

This speaker system has built-in surround speaker, so you can easily enjoy the surround sound.

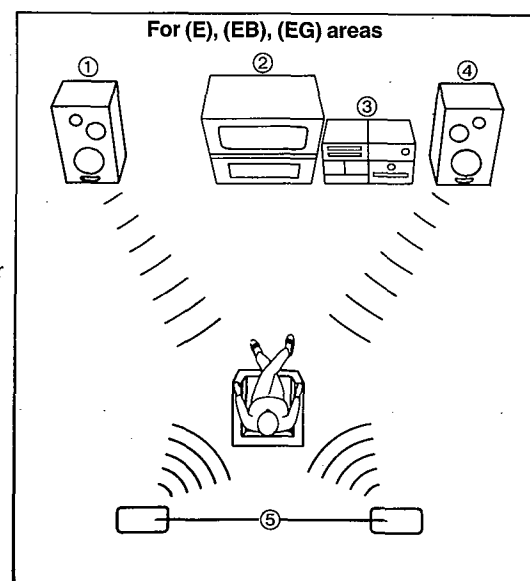

Surround sound effect differs according to where you install the surround speakers. Install them as you like.

■ CONNECTIONS

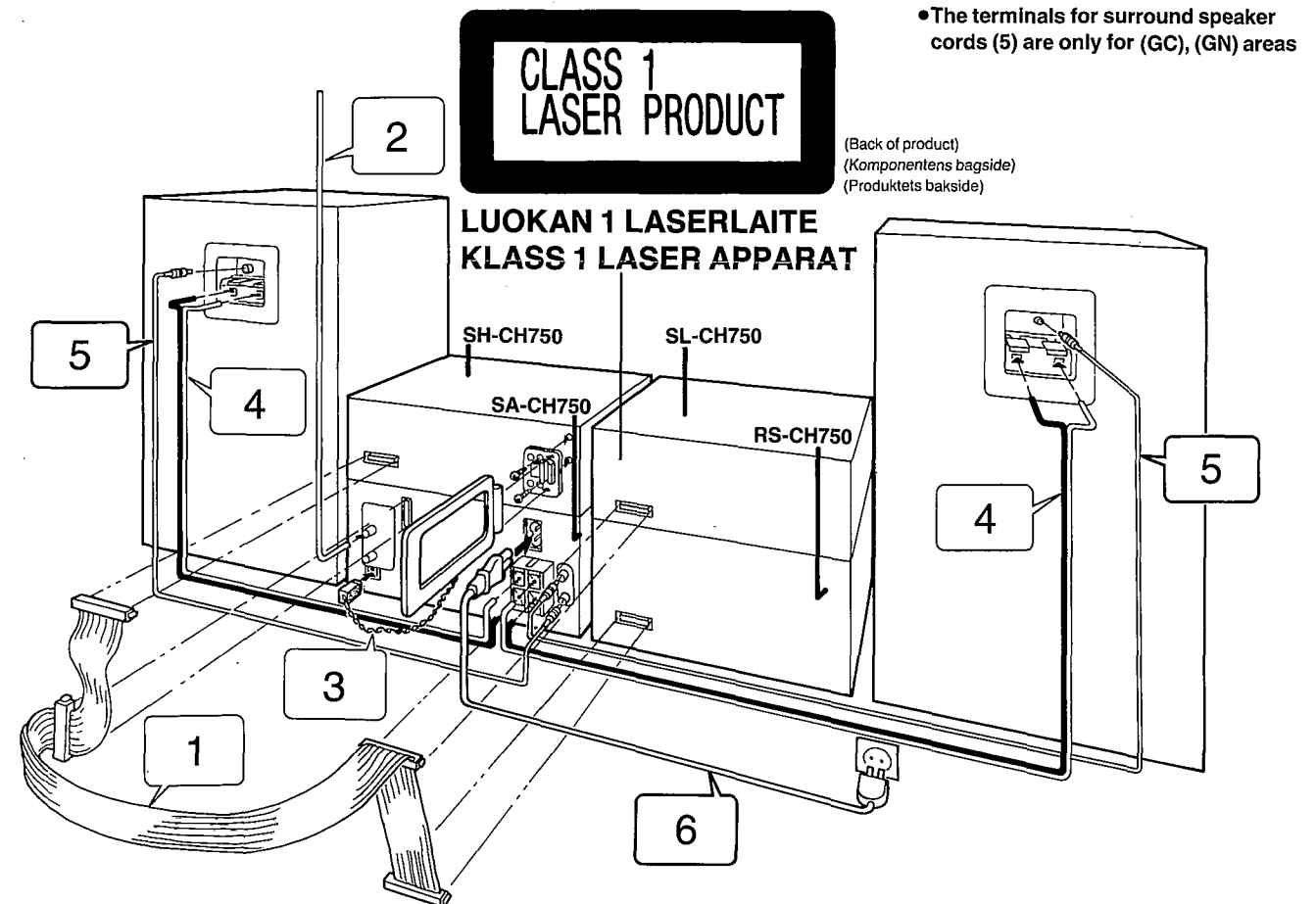

1 Connect the flat cable.

Connecting

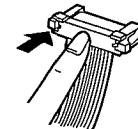

Disconnecting

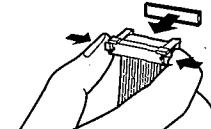

Hold the connector with the recessed part up and press in at the center until you hear a click.

First connect the blue-colored connector to the terminal of the sound processor (A), then connect the rest in the order B, C, D.

Route the cable horizontally (underneath the heat outlet grille) so that the side with the white-color lead is positioned at the front.

After connection, fold and press the cable as flat to the back of the unit as possible.

Heat outlet grille

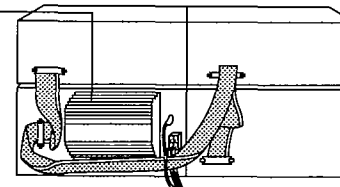

Do not try connecting or disconnecting the flat cable while the power is switched to ON.

2 Connect the FM indoor antenna.

Install the antenna on a wall at a height and in a direction which result in the best reception.

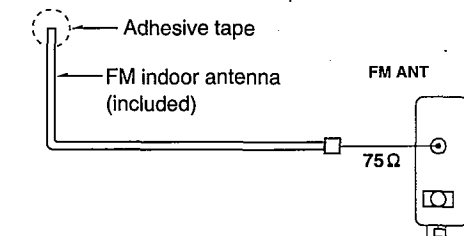

The tip of the internal antenna wire should not come into contact with any metal objects.

When you cannot get a good reception with this FM indoor antenna, we recommend you install an FM outdoor antenna (not included). Disconnect the FM indoor antenna if you install an FM outdoor antenna.

3 Connect the LW/MW loop antenna.

1. Attach the antenna holder with screws (included) to the rear panel of the sound processor.
2. Clamp the antenna to the antenna holder and connect the antenna terminal to the rear panel of the tuner amplifier.
3. Position the loop for the best reception.

You may attach the LW/MW antenna holder to a rack or other structure.

Notes:

- To minimize noise pickup, keep the LW/MW loop antenna away from the speaker cable, power cord, and metal surfaces.
- For better reception, keep the LW/MW loop antenna cord along the heat outlet grille, and away from the flat cable.

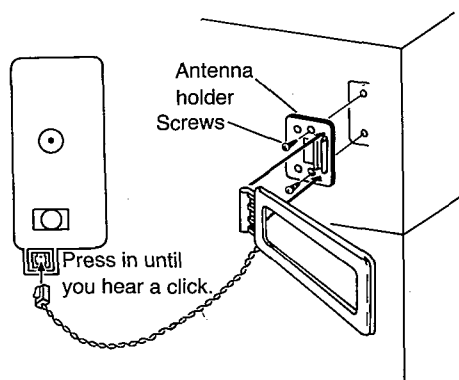

4 Connect the speaker cables.

Connection of speaker cables

1. Strip off the outer covering, and twist the center conductor.

Make sure the bare ends of the wires are not unraveled. (If they are, twist them tight again.)

2. Insert the wire to the rear panel of the speakers, and then pull down the lever.

3. Insert the wire to the rear panel of the tuner amplifier, and close the lever.

Notes:

- To prevent damage to circuitry, never short-circuit positive (+) and negative (-) speaker wires.
- Be sure to connect only positive (red) wires to positive (+) terminals and negative (black) wires to negative (-) terminals.

Note:

- Be sure to connect speaker cables before connecting the AC power supply cord.

5 Connect the surround speaker cord.

For (GC), (GN) areas

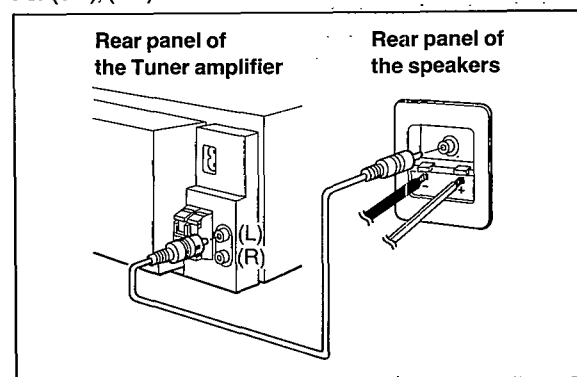

6 Connect the AC power supply cord after you have connected all other cables and cords.

Insertion of Connector

Even when the connector is perfectly inserted, depending on the type of inlet used, the front part of the connector may jut out as shown in the drawing. However there is no problem using the unit.

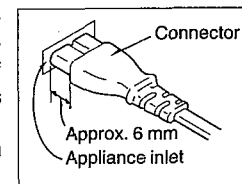

External unit connection

Surround speaker

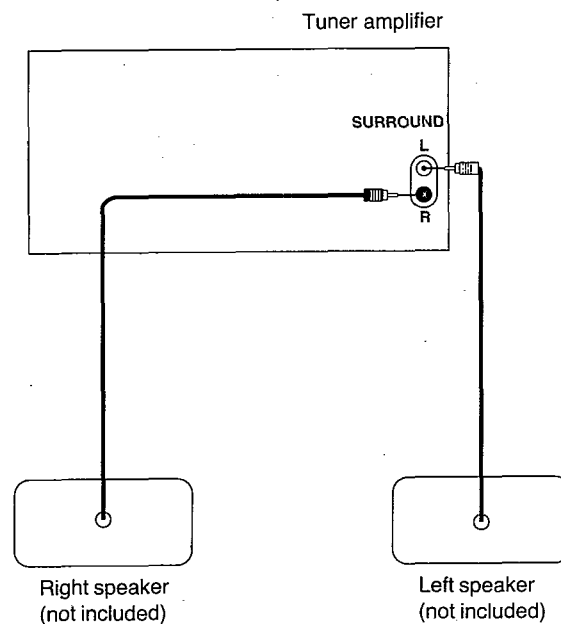

Notes:

Install each speaker left and right at the back of the listening space. Be sure to connect both speaker systems. If only one side is connected, no sound will be heard.

Television

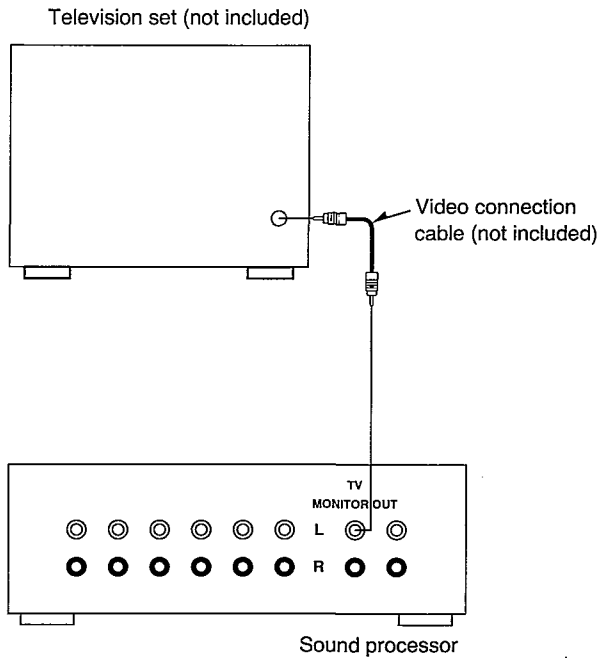

Video deck

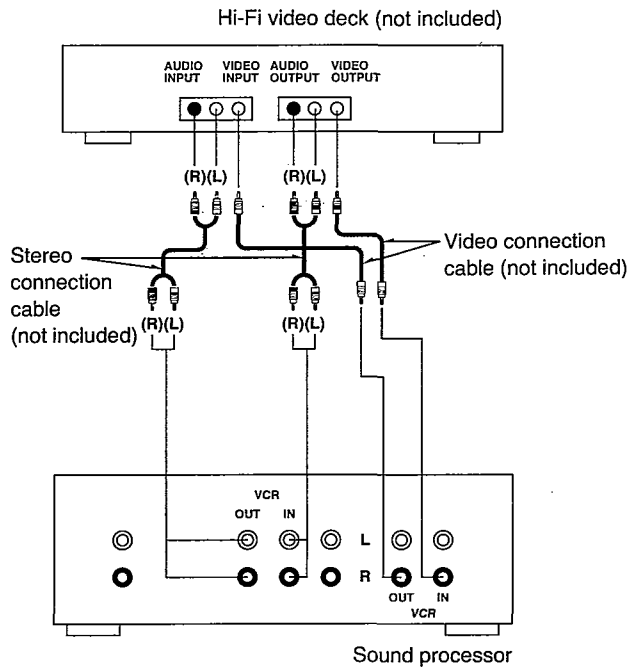

When you use a monaural video deck, connect it with monaural video connection cable.

Center speaker for (GC), (GN) areas

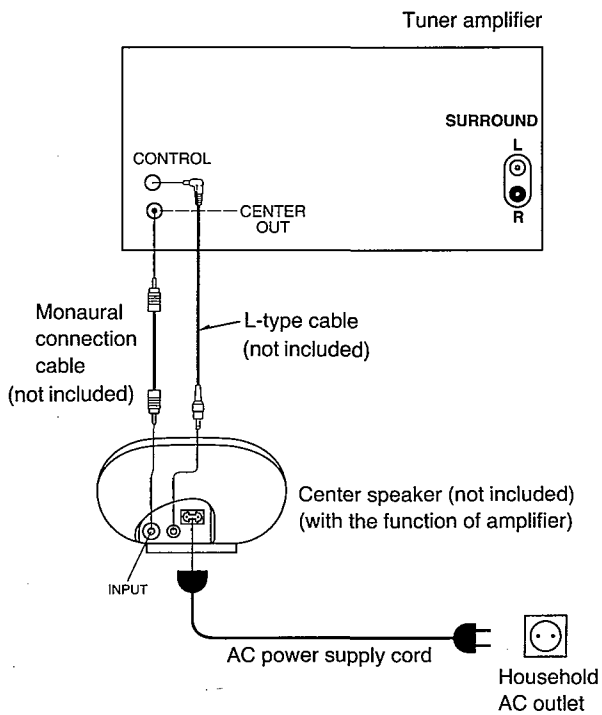

Note:
When you use a center speaker which has not a built-in amplifier, connect it to an another amplifier.

Analog player

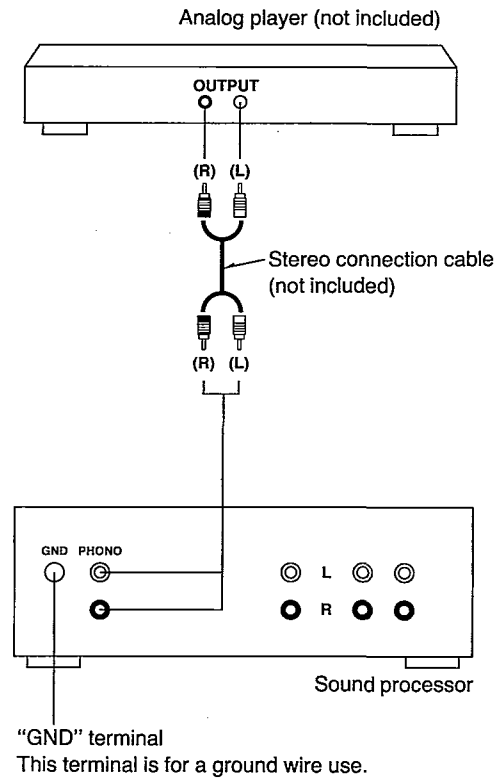

DAT (digital audio tape deck)

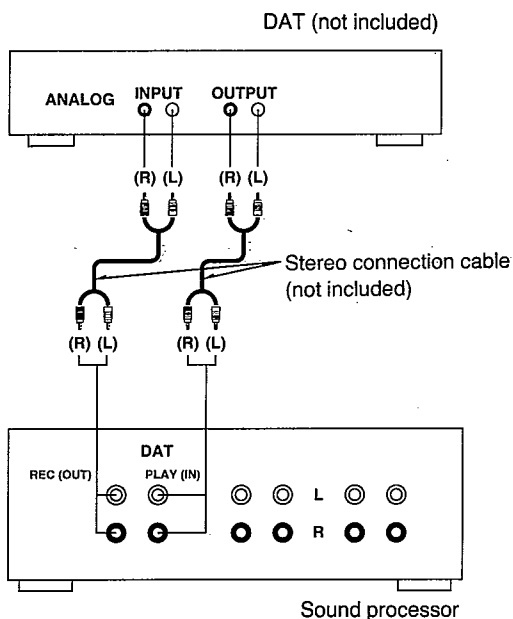

Video disc player

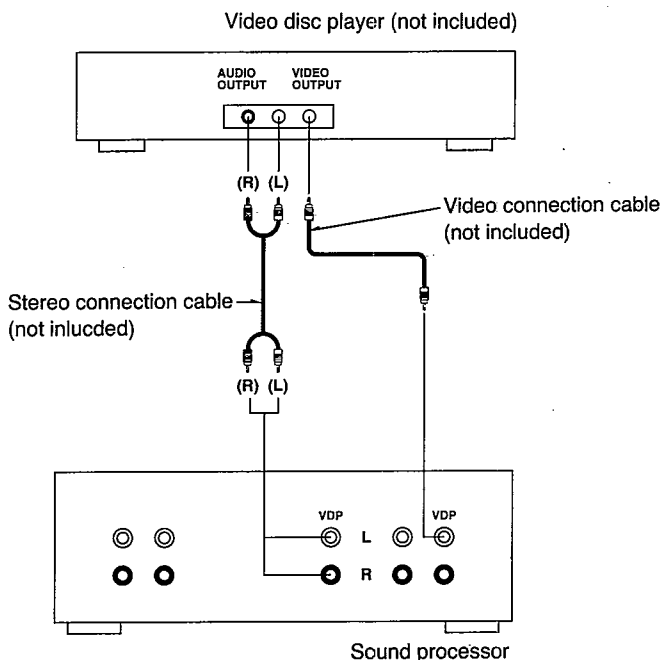

SETTING THE TIME OF DAY

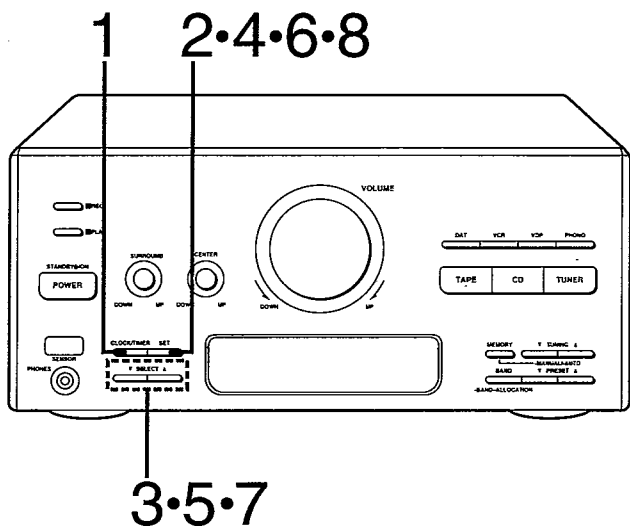

These instructions explain how to set the time for 16:25 (4:25 p.m.) on Wednesday.

Switch on the power.

- 1 Press CLOCK/TIMER to select "CLOCK".**
The display will show CLOCK.
The display will return to what was previously indicated if you allow 7 or more seconds to elapse before you accomplish the next operation.

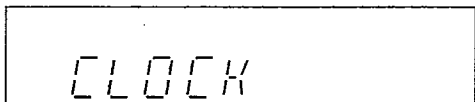

- 2 Press SET.**
The day indicator will start to flash.

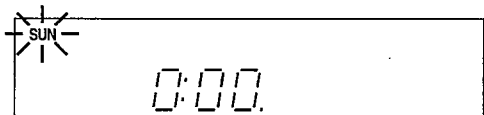

- 3 Press one of the SELECT buttons to select "WED".**

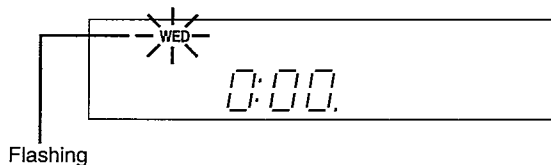

- 4 Press SET.**
- 5 Press one of the SELECT buttons to select "16".**
Going from 23:59 to 00:00 on the hour display will not change the day display.

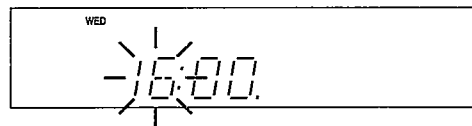

- 6 Press SET.**
- 7 Press one of the SELECT buttons to select "25".**
Going from 59 to 00 on the minute display will not change the hour display.

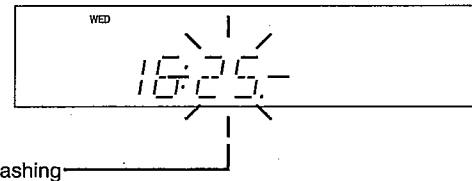

- 8 Press SET to finish setting the time.**
After about 2 seconds, the display will return to what it were before entering the clock setting mode.

To display the clock again, press CLOCK/TIMER. The display will show "CLOCK", and then clock will appear for 5 seconds. "E" appears on the display if the power cord has been once disconnected or there has been a power failure. If this happens, reset the time.

DISASSEMBLY INSTRUCTIONS

"ATTENTION SERVICER"

Some chassis components may have sharp edges. Be careful when disassembling and servicing.

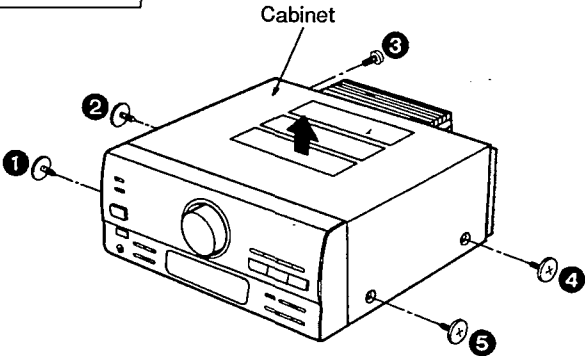
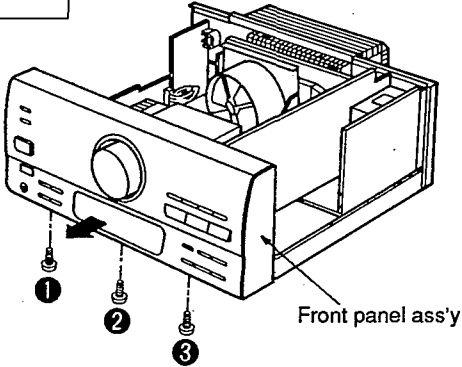
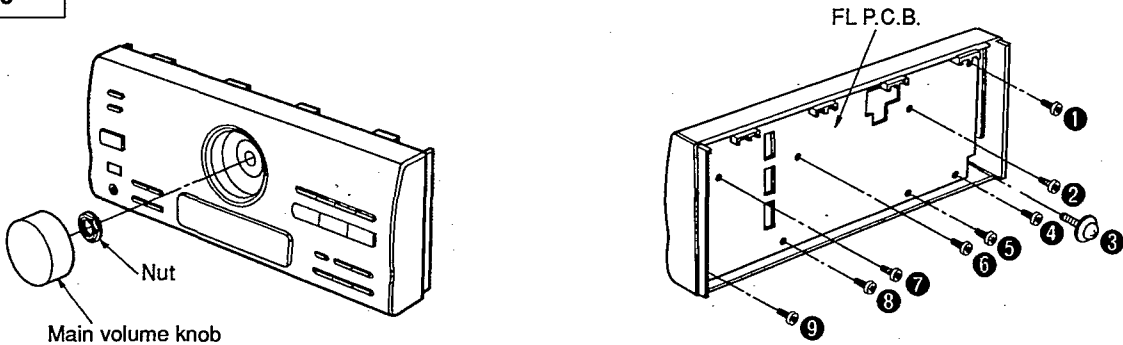
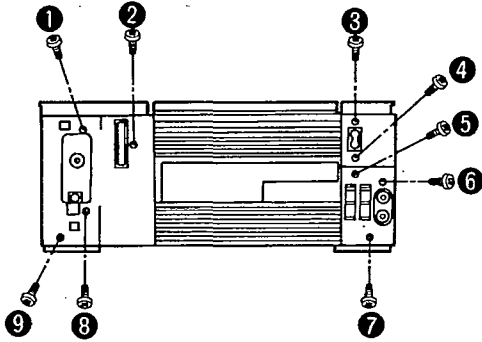
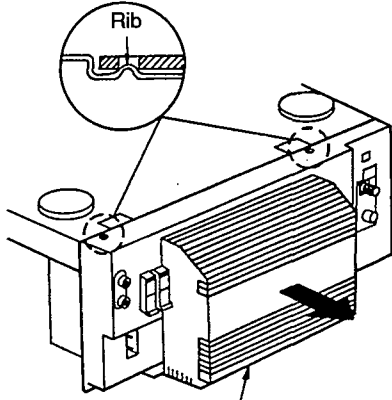
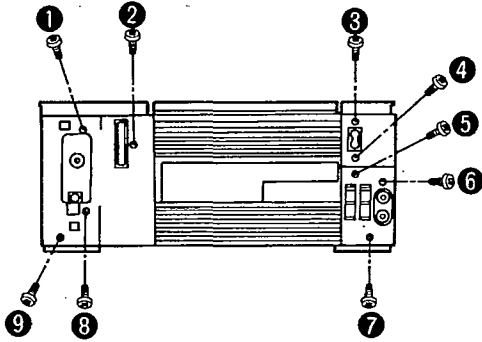
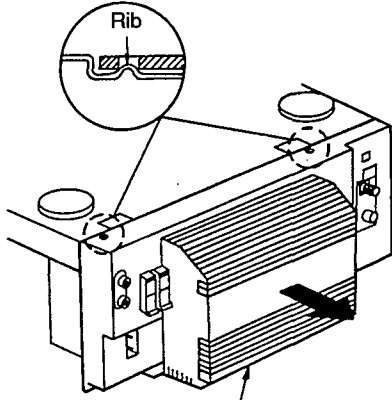
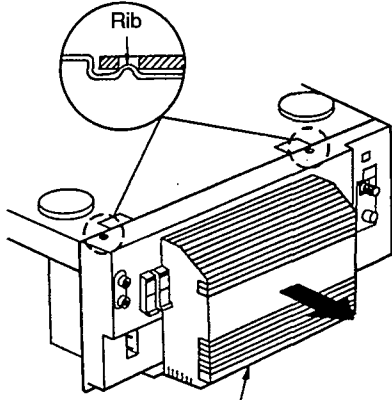
Ref. No. 1	Removal of the Cabinet	Ref. No. 2	Removal of the Front Panel Ass'y
Procedure 1	 <p>1. Remove the 5 screws (1~5). 2. Remove the cabinet in the direction of arrow.</p>	Procedure 1→2	 <p>1. Remove the 3 screws (1~3). 2. Remove the front panel ass'y in the direction of arrow.</p>
Ref. No. 3	Removal of the FL P.C.B.	 <p>1. Pull out the main volume knob. 2. Remove the nut.</p> <p>3. Remove the 9 screws (1~9).</p>	
Procedure 1→2→3	 <p>1. Remove the 9 screws (1~9).</p>	Ref. No. 4	Removal of the Rear Grill Ass'y
Ref. No. 4	Removal of the Rear Grill Ass'y	Procedure 1→4	 <p>2. Remove the 2 ribs. 3. Remove the rear grill ass'y in the direction of arrow.</p>
Procedure 1→4	 <p>1. Remove the 9 screws (1~9).</p>	 <p>2. Remove the 2 ribs. 3. Remove the rear grill ass'y in the direction of arrow.</p>	 <p>2. Remove the 2 ribs. 3. Remove the rear grill ass'y in the direction of arrow.</p>

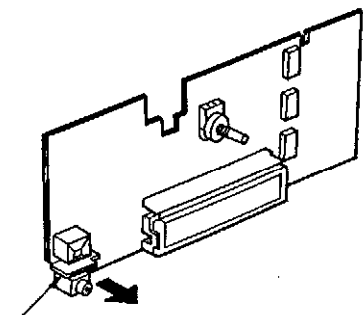
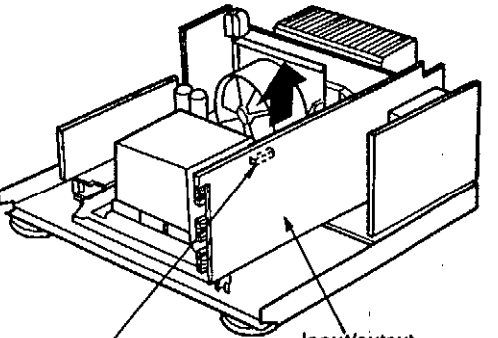
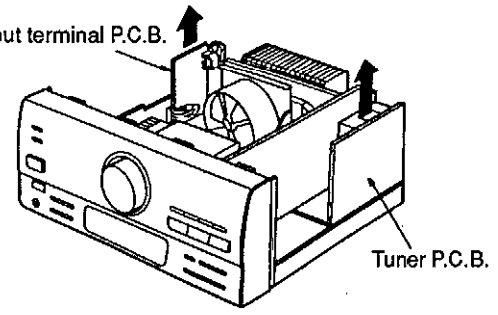
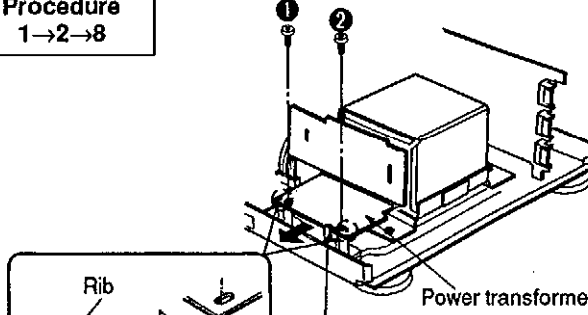
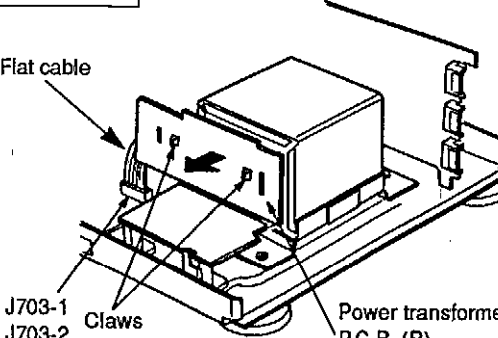
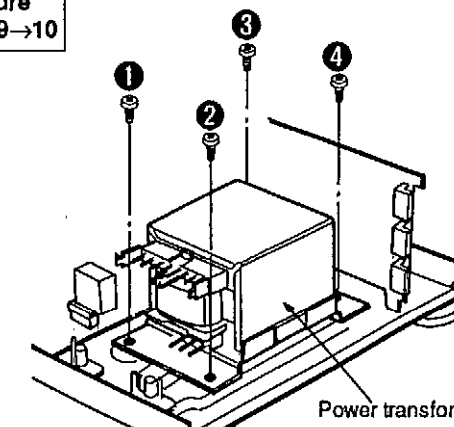
Ref. No. 5	Removal of the Headphones Jack P.C.B.	Procedure 1→2→3→5	Ref. No. 6	Removal of the Input/output Terminal P.C.B.	Procedure 1→2→4→6	
 <p>Headphones jack P.C.B.</p> <p>Remove the headphones jack P.C.B. in the direction of arrow.</p>		 <p>JK351 Input/output terminal P.C.B.</p> <ol style="list-style-type: none"> Remove the connector (JK351). Remove the input/output terminal P.C.B. in the direction of arrow. 		Ref. No. 7		Removal of the AC Input Terminal P.C.B. and Tuner P.C.B.
 <p>AC input terminal P.C.B. Tuner P.C.B.</p> <p>Removal of the AC Input Terminal P.C.B. Remove the AC input terminal P.C.B. in the direction of arrow.</p> <p>Removal of the tuner P.C.B. Remove the tuner P.C.B. in the direction of arrow.</p>		Ref. No. 8		Removal of the Power Transformer P.C.B. (A)	Procedure 1→2→8	
		 <p>Rib Claw Power transformer P.C.B. (A)</p> <ol style="list-style-type: none"> Remove the 2 screws (1, 2). Release the claw. Remove the 2 ribs. Remove the power transformer P.C.B. (A) in the direction of arrow. 		Ref. No. 9		Removal of the Power Transformer P.C.B. (B)
 <p>Flat cable J703-1 J703-2 Claws Power transformer P.C.B. (B)</p> <ol style="list-style-type: none"> Remove the flat cable (J703-1, J703-2). Release the 2 claws. Remove the power transformer P.C.B. (B) in the direction of arrow. 		Ref. No. 10		Removal of the Power Transformer	Procedure 1→2→8→9→10	
		 <p>Power transformer</p> <p>Remove the 4 screws (1-4).</p>		- 11 -		

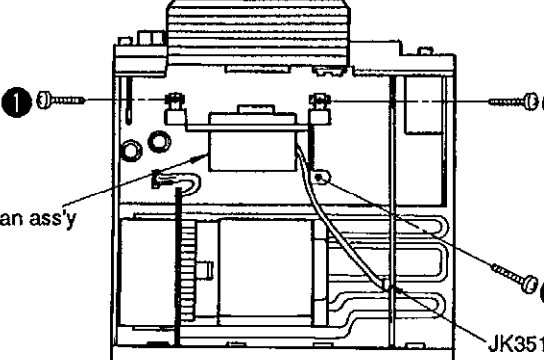
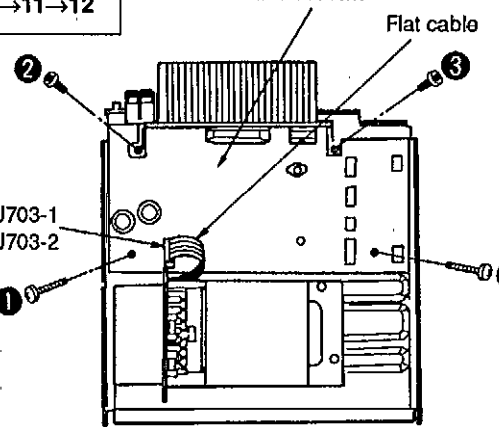
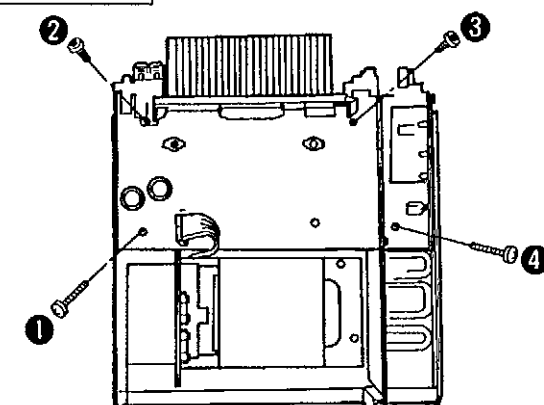
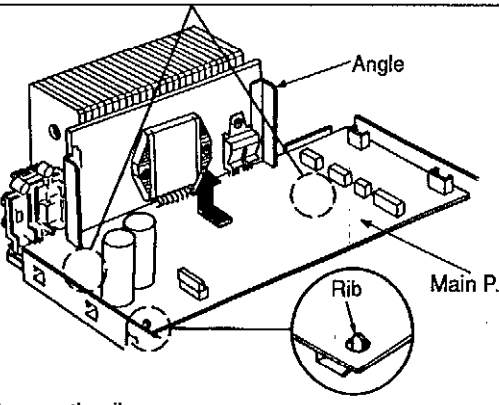
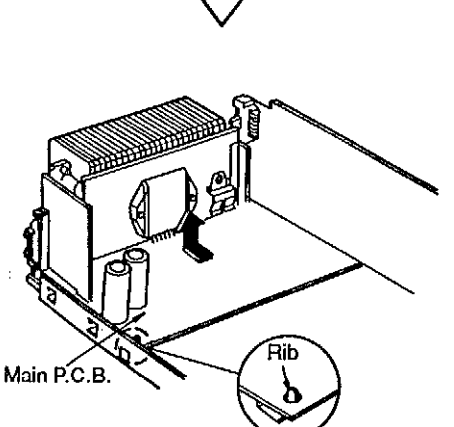
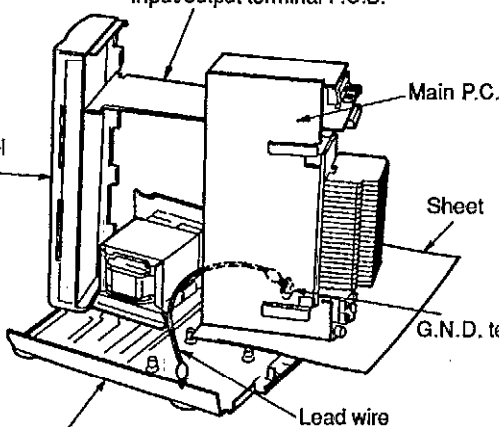
Ref. No. 11	Removal of the Fan Ass'y	Procedure 1→11	Ref. No. 12	Removal of the main P.C.B.	Procedure 1→2→4→6 →7→11→12				
 <p>Fan ass'y JK351</p> <ol style="list-style-type: none"> Remove the connector (JK351). Remove the 3 screws (1-3). 		 <p>Main P.C.B. Flat cable J703-1 J703-2 JK351</p> <ol style="list-style-type: none"> Remove the 4 screws (1-4). Remove the flat cable (J703-1, J703-2). 		Ref. No. 13		How to check the Main P.C.B.			
 <p>When checking the soldered surfaces of main P.C.B. and replacing the parts, do as shown below.</p> <ol style="list-style-type: none"> Remove the 4 screws (1-4). 		<p>NOTE Insert the projection on the angle into the hole of the bottom board ass'y and then install the Main P.C.B.</p> <p>[Bottom view] Projection</p>  <p>Angle Main P.C.B. Rib</p> <ol style="list-style-type: none"> Remove the rib. Remove the main P.C.B. in the direction of arrow. 		 <p>Input/output terminal P.C.B. Main P.C.B. Front panel ass'y Sheet G.N.D. terminal Bottom board ass'y Lead wire</p> <ol style="list-style-type: none"> Remove the rib. Remove the main P.C.B. in the direction of arrow. 		 <p>Input/output terminal P.C.B. Main P.C.B. Sheet G.N.D. terminal Bottom board ass'y Lead wire</p> <ol style="list-style-type: none"> Connect the G.N.D. terminal to the bottom board ass'y by the lead wire. Reinstall the front panel ass'y to the input/output terminal P.C.B. 		- 12 -	

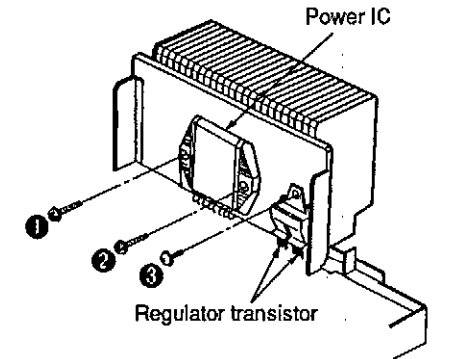
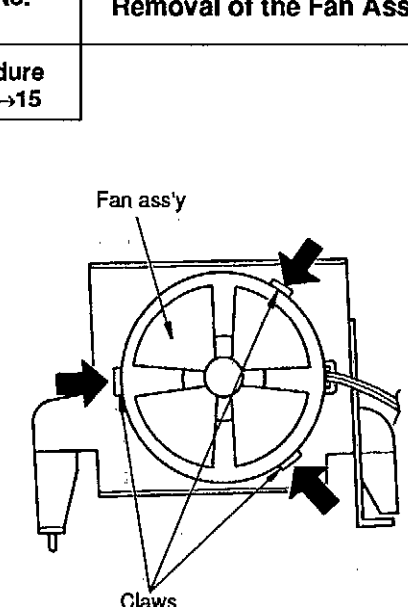
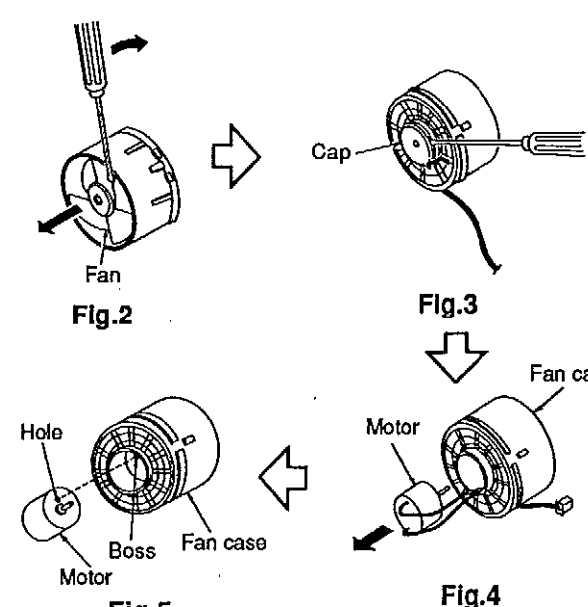
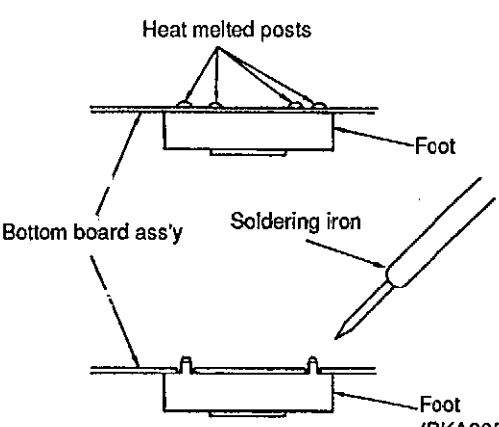
Ref. No. 14	Removal of the Power IC and Regulator Transistor	Procedure 1→2→4→6 →7→11→12→14	Ref. No. 15	Removal of the Fan Ass'y	Procedure 1→11→15		
 <p>Power IC Regulator transistor</p> <ol style="list-style-type: none"> Unsolder the power IC or regulator transistors. Remove the 3 screws (1-3). <p>When mounting the power IC or regulator transistor, apply silicone compound (RFKX0002) to the rear side of power IC or regulator transistors.</p>				 <p>Fan ass'y Claws</p> <p>1. Release the 3 claws (shown in Fig. 1).</p>			
		 <p>Cap Fan Fig.2</p> <p>Motor Fan case Fig.4</p> <p>Hole Boss Fan case Motor Fig.5</p> <ol style="list-style-type: none"> Insert a screwdriver at the root of the fan (shown in Fig. 2). Remove the cap (shown in Fig. 3). Remove the motor from the fan case (shown in Fig. 4). When mounting the motor, align the fan case projection with the hole of the motor (shown in Fig. 5). 		<p>Replacement of the Foot</p> <ol style="list-style-type: none"> Remove the 4 heat melted posts on the Bottom board ass'y with a pair of nippers or similar tool. To replace the foot (RKA0055-N) on the Bottom board ass'y, melt the 4 posts with a soldering iron.  <p>Heat melted posts Foot Bottom board ass'y Soldering iron Foot (RKA0055-N)</p>		- 13 -	

SCHEMATIC DIAGRAM • MAIN, POWER TRANSFORMER (A)/(B) AND AC IN TERMINAL CIRCUIT (Parts list on pages 33-37.)

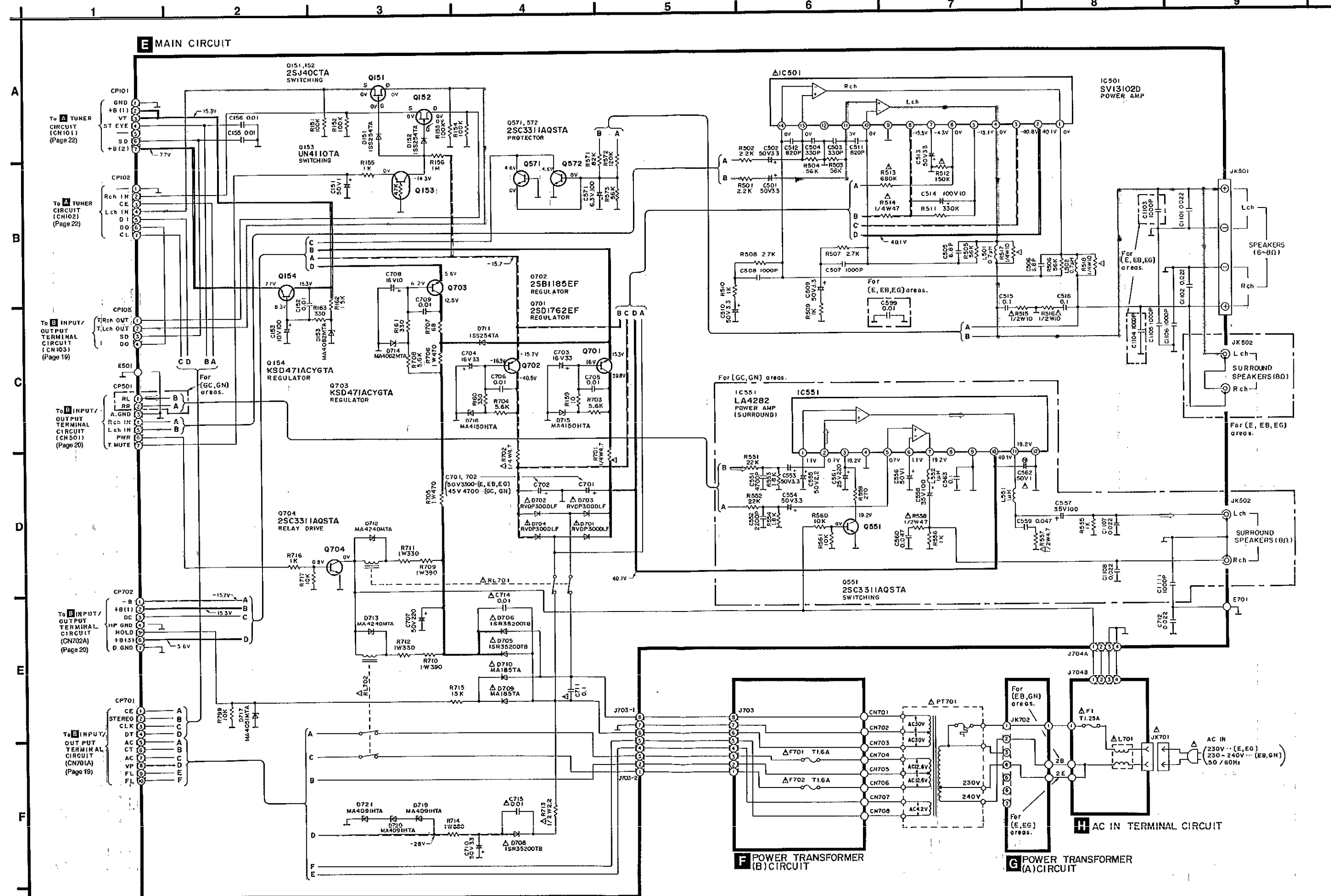

- Notes:**
- S601 : Power "STANDBY ϕ /ON" switch (POWER/STANDBY ϕ /ON)
 - S602 : Timer recording switch (REC TIMER)
 - S603 : Timer play switch (PLAY TIMER)
 - S604 : Clock/timer switch (CLOCK/TIMER)
 - S605 : Timer select switch (∇)
 - S606 : Timer select switch (\blacktriangle)
 - S607 : Setting switch (SET)
 - S608 : Preset memory switch (MEMORY, -MANUAL, -AUTO)
 - S609 : Preset tuning switch (∇)
 - S610 : Preset tuning switch (\blacktriangle)
 - S611 : Band select/allocation charge switch (-BAND -ALLOCATION)
 - S612 : Tuning switch (∇)
 - S613 : Tuning switch (\blacktriangle)
 - S614 : Input selector switch (TUNER)
 - S615 : Input selector switch (CD)
 - S616 : Input selector switch (TAPE)
 - S617 : Input selector switch (PHONO)
 - S618 : Input selector switch (DAT)
 - S619 : Input selector switch (VDP)
 - S620 : Input selector switch (VCR)
 - S701 : VOLTAGE SELECTOR switch in "220 V" position (110 V/127 V/220 V/240 V) for (GC) area only
- Indicated voltage values are the standard values for the unit measured by the DC electronic circuit tester (high-impedance) with the chassis taken as standard.
Therefore, there may exist some errors in the voltage values, depending on the internal impedance of the DC circuit tester.
No mark: FM mode () : MW mode < > : LW mode

Important safety notice:
Components identified by Δ mark have special characteristics important for safety. Furthermore, special parts which have purposes of fire-retardant (resistors), high-quality sound (capacitors), low-noise (resistors), etc. are used. When replacing any of components, be sure to use only manufacturer's specified parts shown in the parts list.

Caution!
IC and LSI are sensitive to static electricity. Secondary trouble can be prevented by taking care during repair. Cover the parts boxes made of plastics with aluminum foil. Ground the soldering iron. Put a conductive mat on the work table. Do not touch the legs of IC or LSI with the fingers directly.

The supply part number is described alone in the replacement parts list.

Ref. No.	Production Parts No.	Supply Parts No.
IC202	M5219FPTA	M5219FP
IC203	BA4558FT1	SVIBA4558F
IC301	M5218AL	M5218L
IC602	RCDHC-278-E	RCDHC-278

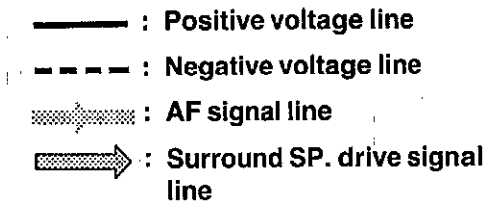

This schematic diagram may be modified at any time with the development of new technology.

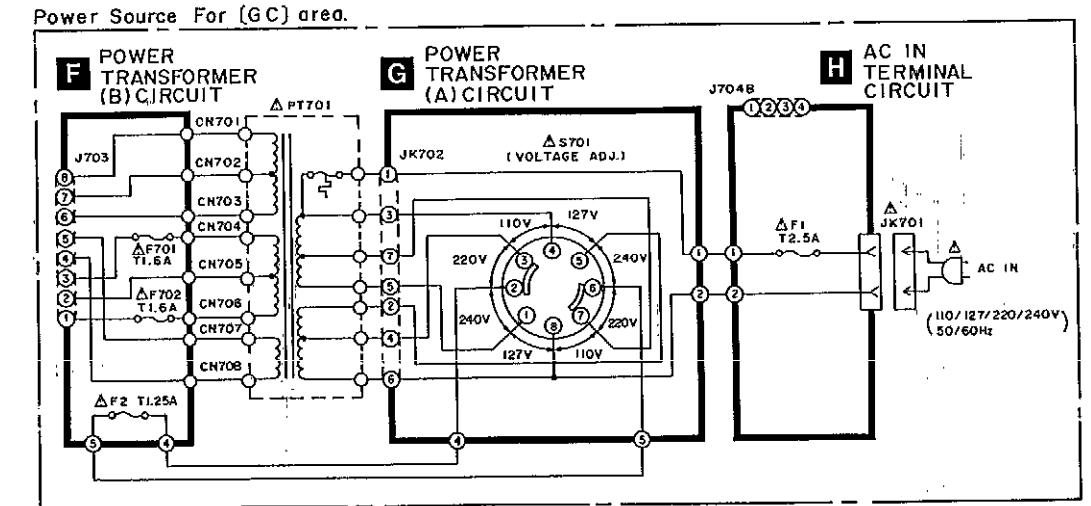

SCHEMATIC DIAGRAM • FL AND HEADPHONES CIRCUIT (Parts list on pages 33~37.)

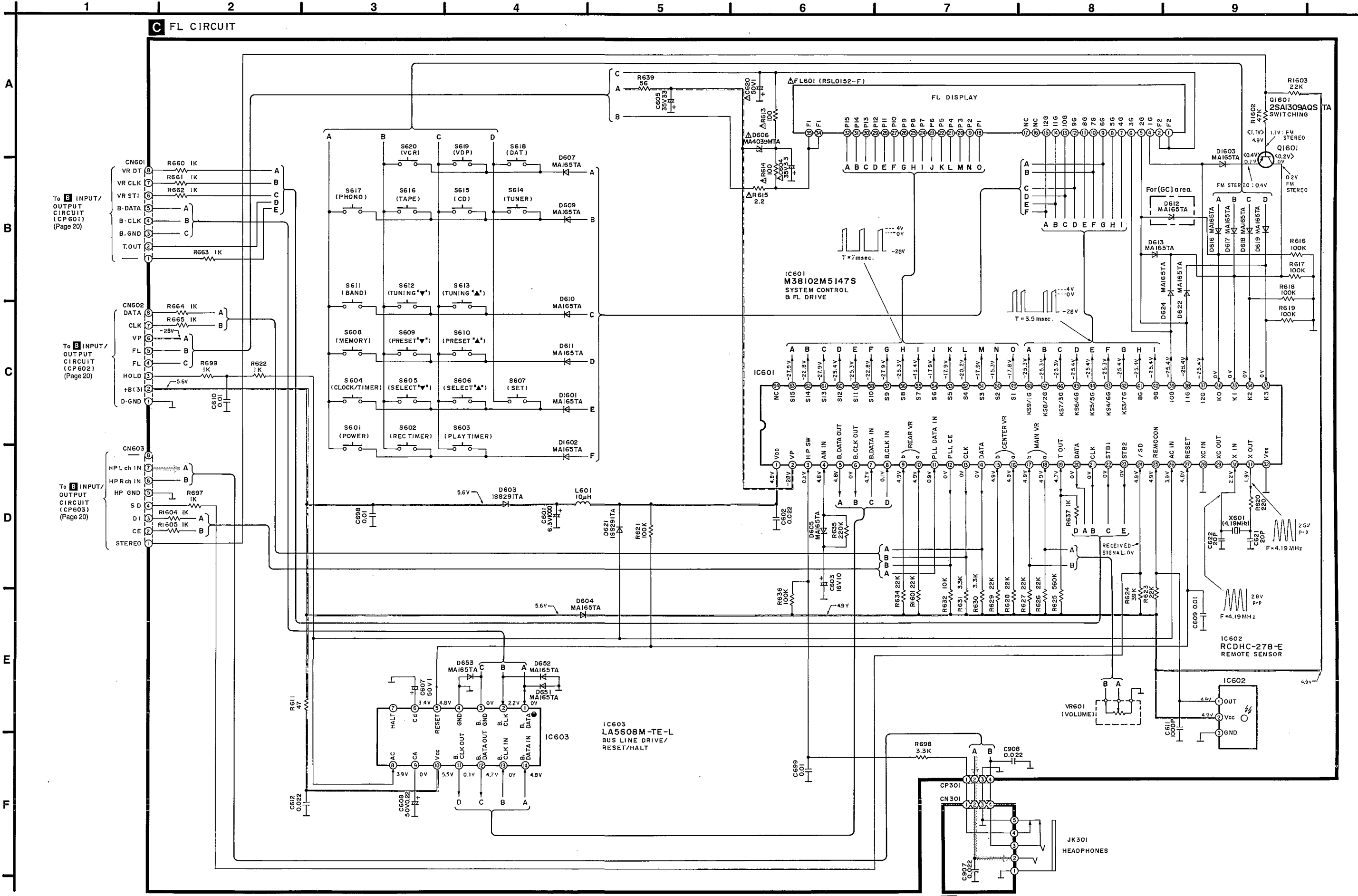

C FL CIRCUIT

D HEADPHONES JACK CIRCUIT

SCHEMATIC DIAGRAM • INPUT/OUTPUT TERMINAL CIRCUIT (Parts list on pages 33~37.)

Positive voltage line, Negative voltage line, AF signal line, Surround SP. drive signal line

B INPUT/OUTPUT TERMINAL CIRCUIT

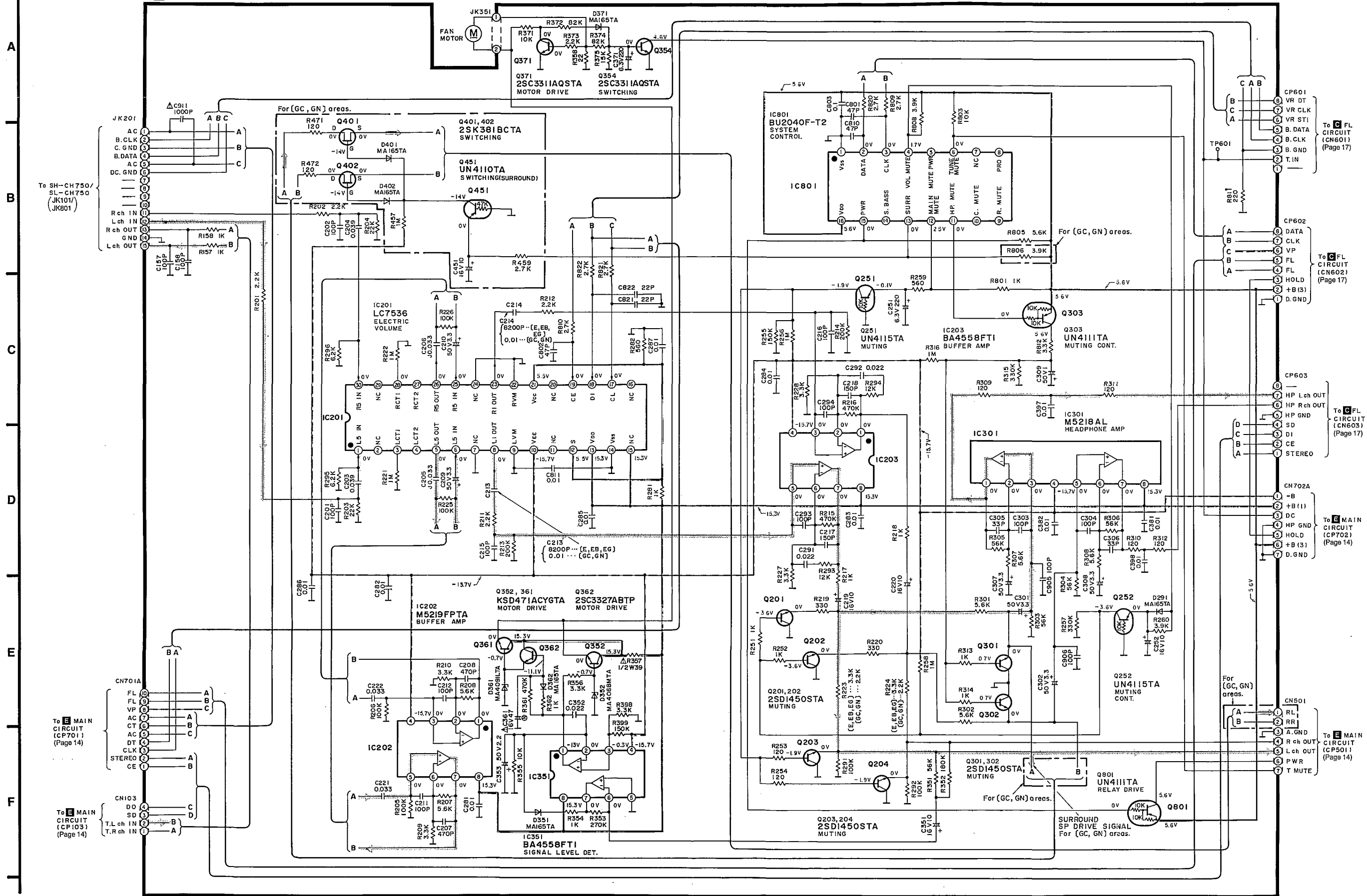

A

B

C

D

E

F

SCHEMATIC DIAGRAM • TUNER CIRCUIT (Parts list on pages 33~37.)

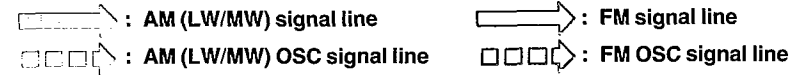

A TUNER CIRCUIT

Indicated voltage values are the standard values for the unit measured by the DC electronic circuit tester (high-impedance) with the chassis taken as standard. Therefore, there may exist some errors in the voltage values, depending on the internal impedance of the DC circuit tester. No mark: FM mode (): MW mode < >: LW mode

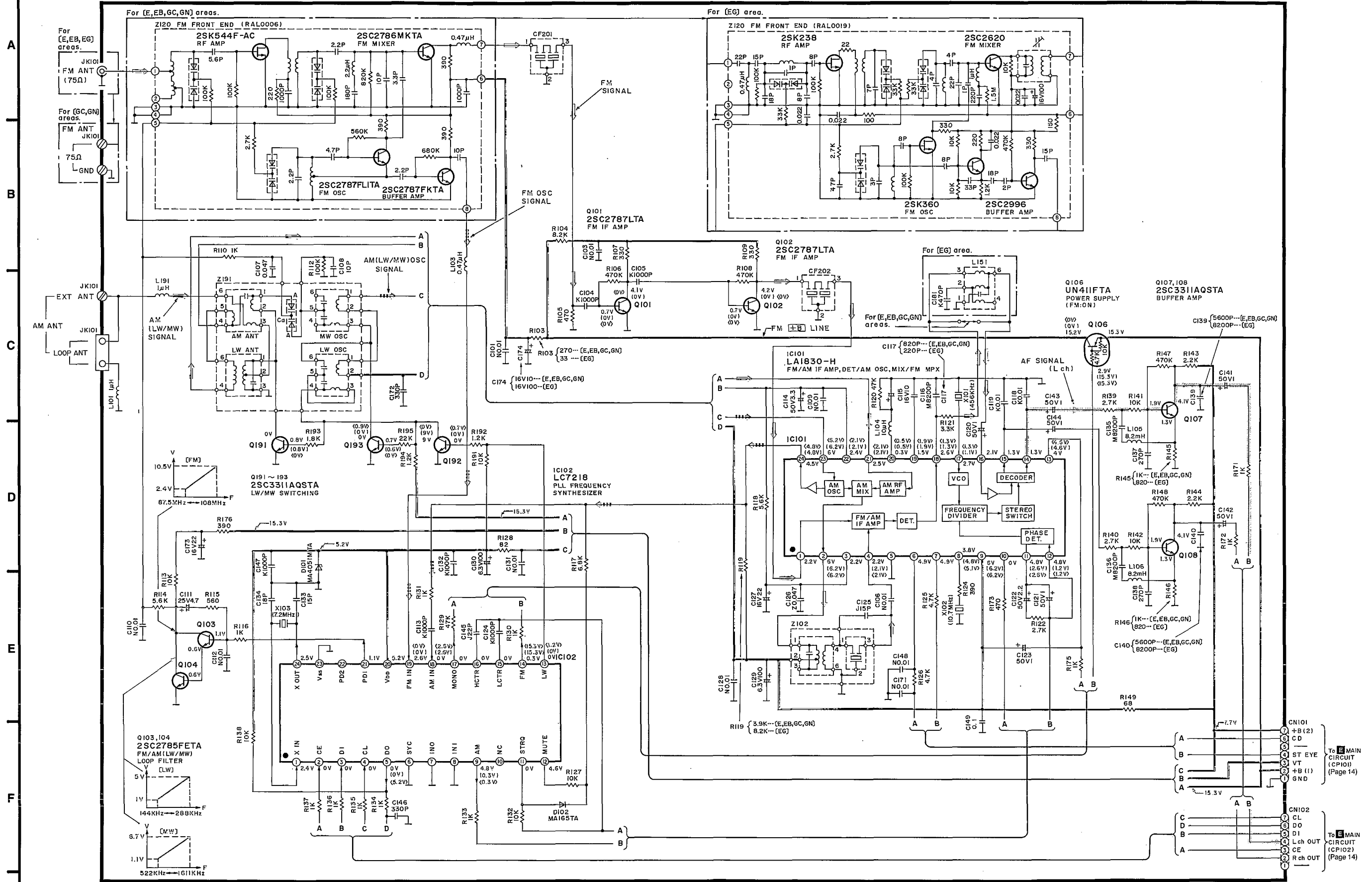

REPLACEMENT PARTS LIST

Notes: *Important safety notice:

 Components identified by Δ mark have special characteristics important for safety.

Furthermore, special parts which have purposes of fire-retardant (resistors), high-quality sound (capacitors), low-noise (resistors), etc. are used.

When replacing any of components, be sure to use only manufacturer's specified parts shown in the parts list.

*The parenthesized indications in the Remarks columns specify the areas. (Refer to the cover page for area.)

*Parts without these indications can be used for all areas.

*Remote Control Ass'y:

Supply period for three years from termination of production.

Ref. No.	Part No.	Part Name & Description	Remarks	Ref. No.	Part No.	Part Name & Description	Remarks
		INTEGRATED CIRCUIT(S)				DIODE(S)	
IC101	LA1830-H	I. C. FM/AM IF AMP. /AM OSC		D101	MA4051MTA	DIODE	
IC102	LC7218	I. C. PLL FREQ. SYNTHESIZER		D102	MA165	DIODE	
IC201	LC7536	I. C. ELECTRIC VOLUME		D151, 152	1SS254TA	DIODE	
IC202	M5219FP	I. C. BUFFER AMP.		D153	MA4082MTA	DIODE	
IC203	SVIBA4558F	I. C. BUFFER AMP.		D291	MA165	DIODE	
IC301	M5218L	I. C. HEADPHONE AMP.		D351	MA165	DIODE	
IC351	SVIBA4558F	I. C. SIGNAL DET.		D352	MA4068M	DIODE	
IC501	SVI3102D	I. C. POWER AMP.	Δ	D361	MA4091LTA	DIODE	
IC551	LA4282	I. C. POWER AMP. (SURROUND)	(GC, GN)	D362	MA165	DIODE	
IC601	M38102M5147S	I. C. FL DRIVE/SYSTEM CONT.		D371	MA165	DIODE	
IC602	RCDHC-278	I. C. REMOTE SENSOR		D401, 402	MA165	DIODE	(GC, GN)
IC603	LA5608M-TE-L	I. C. BUS LINE/HALT/RESET		D603	1SS291TA	DIODE	
IC801	BU2040F-T2	I. C. SYSTEM CONT.		D604, 605	MA165	DIODE	
		TRANSISTOR(S)		D606	MA4039MTA	DIODE	Δ
				D607	MA165	DIODE	
Q101, 102	2SC2787L	TRANSISTOR		D609-611	MA165	DIODE	
Q103, 104	2SC2785FE	TRANSISTOR		D612	MA165	DIODE	(GC)
Q106	UN411FTA	TRANSISTOR		D613	MA165	DIODE	
Q107, 108	2SC3311A-Q	TRANSISTOR		D616-619	MA165	DIODE	
Q151, 152	2SJ40CTA	TRANSISTOR		D621	1SS291TA	DIODE	
Q153	UN4110TA	TRANSISTOR		D622	MA165	DIODE	
Q154	KSD471ACYGTA	TRANSISTOR		D624	MA165	DIODE	
Q191-193	2SC3311A-Q	TRANSISTOR		D651-653	MA165	DIODE	
Q201-204	2SD1450RTA	TRANSISTOR		D701-704	RVDP300DLF	DIODE	Δ
Q251, 252	UN4115	TRANSISTOR		D705, 706	1SR35200TB	DIODE	Δ
Q301, 302	2SD1450RTA	TRANSISTOR		D708	1SR35200TB	DIODE	Δ
Q303	UN4111	TRANSISTOR		D709, 710	MA185TA	DIODE	Δ
Q352	KSD471ACYGTA	TRANSISTOR		D711	1SS254TA	DIODE	
Q354	2SC3311A-Q	TRANSISTOR		D712, 713	MA4240H	DIODE	
Q361	KSD471ACYGTA	TRANSISTOR		D714	MA4062MTA	DIODE	
Q362	2SC3327-A	TRANSISTOR		D715, 716	MA4150M	DIODE	
Q371	2SC3311A-Q	TRANSISTOR		D717	MA4051MTA	DIODE	
Q401, 402	2SK381BCDTA	TRANSISTOR	(GC, GN)	D719-721	MA4091HTA	DIODE	
Q451	UN4110TA	TRANSISTOR	(GC, GN)	D1601-1603	MA165	DIODE	
Q551	2SC3311A-Q	TRANSISTOR	(GC, GN)			VARIABLE RESISTOR(S)	
Q571, 572	2SC3311A-Q	TRANSISTOR					
Q701	2SD1762EF	TRANSISTOR		VR601	EVQWVF2024B	V. R. MAIN VOLUME CONTROL	
Q702	2SB1185EF	TRANSISTOR				COMPONENT COMBINATION(S)	
Q703	KSD471ACYGTA	TRANSISTOR					
Q704	2SC3311A-Q	TRANSISTOR					
Q801	UN4111	TRANSISTOR		Z102	RL12Z006M-T	COMPONENT COMBINATION	
Q1601	2SA1309A-R	TRANSISTOR		Z120	RAL0006	TUNER PACK(FM FRONT END)	(E, EB, GC, GN)

Ref. No.	Part No.	Part Name & Description	Remarks	Ref. No.	Part No.	Part Name & Description	Remarks
Z120	RAL0019	TUNER PACK(FM FRONT END)	(EG)	S610	EVQ21405R	SW, PRESET(UP)	
Z191	RLA6Z005M-T	COMPONENT COMBINATION		S611	EVQ21405R	SW, BAND	
		COIL(S)		S612	EVQ21405R	SW, TUNING(DOWN)	
				S613	EVQ21405R	SW, TUNING(UP)	
L101	ELESN1R0MA	COIL		S614	EVQ21405R	SW, TUNER	
L103	ELEXT100KA9	COIL		S615	EVQ21405R	SW, CD	
L104	ELEXT100KA9	COIL		S616	EVQ21405R	SW, TAPE	
L105, 106	RLQZB822KT-D	COIL		S617	EVQ21405R	SW, PHONO	
L151	SLM1B10M-1M	COIL	(EG)	S618	EVQ21405R	SW, DAT	
L191	ELESN1R0MA	COIL		S619	EVQ21405R	SW, VDP	
L501, 502	SLQY07G-40	COIL		S620	EVQ21405R	SW, VCR	
L551, 552	ELEV1ROKA	COIL	(GC, GN)	S701	ESE37263	SW, VOLTAGE SELECTOR	△(GC)
L601	ELEXT100KA9	COIL				JACK(S)	
L701	RLQZ271M	COIL	△(E, EB, EG, GN)				
		FILTER(S)		J703	RWJ1808110XX	FLAT CABLE(8P)	
				J703-1, 2	RJS1A6604	SOCKET(4P)	
CF201	RLFFETWND01M	FILTER	(E, EB, GC, GN)	J704A	RJT057W004-1	CONNECTOR(4P)	
CF201	RLFFETNGD01L	FILTER	(EG)	J704B	RJU057W004	SOCKET(4P)	
CF202	RLFFETWND01M	FILTER	(E, EB, GC, GN)	CN101, 102	RJU063W07T	SOCKET(7P)	
CF202	RLFFETNGD01L	FILTER	(EG)	CN103	RJU057W004	SOCKET(4P)	
		OSCILLATOR(S)		CN301	RJU057W004	SOCKET(4P)	
				CN501	RJU057W007	SOCKET(7P)	
X101	RSXZ456KM07M	OSCILLATOR(456KHz)		CN601-603	RJT003K008-1	CONNECTOR(8P)	
X102	RLFDFTD03M	OSCILLATOR(10.7MHz)		CN701	RJS1A1101T1	SOCKET(1P)	
X103	SVQ49U722-S	OSCILLATOR(7.2MHz)		CN701A	RJU057W010	SOCKET(10P)	
X601	RSXA4M19S03	OSCILLATOR(4.19MHz)		CN702	RJS1A1101T1	SOCKET(1P)	
		DISPLAY(S)		CN702A	RJU057W007	SOCKET(7P)	
				CN703-708	RJS1A1101T1	SOCKET(1P)	
FL601	RSL0152-F	FL DISPLAY	△	CP101, 102	RJT063W07T	CONNECTOR(7P)	
		FUSE(S)		CP103	RJT057W004-1	CONNECTOR(4P)	
				CP301	RJT057W004-1	CONNECTOR(4P)	
F1	XBA2C12TB0S	FUSE 250V T1. 25A	△(E, EB, EG, GN)	CP501	RJT057W007-1	CONNECTOR(7P)	
F1	XBA2C25TB0	FUSE 250V T2. 5A	△(GC)	CP601-603	RJU003K008M1	SOCKET(8P)	
F2	XBA2C12TB0	FUSE 250V T1. 25A	△(GC)	CP701	RJT057W010-1	CONNECTOR(10P)	
F701, 702	XBA2C16TB0	FUSE 250V T1. 6A	△	CP702	RJT057W007-1	CONNECTOR(7P)	
		SWITCH(ES)				EARTH TERMINAL(S)	
S601	EVQ21405R	SW, POWER		E501	SNE1004-1	GND PLATE	
S602	EVQ21405R	SW, TIMER REC		E701	SNE1004-1	GND PLATE	
S603	EVQ21405R	SW, TIMER PLAY				FUSE HOLDER(S)	
S604	EVQ21405R	SW, CLOCK/TIMER					
S605	EVQ21405R	SW, SELECT(DOWN)		FC1-6	EYF52BC	FUSE HOLDER	△
S606	EVQ21405R	SW, SELECT(UP)		FC7, 8	EYF52BC	FUSE HOLDER	△(GC)
S607	EVQ21405R	SW, SET				RELAY(S)	
S608	EVQ21405R	SW, MEMORY					
S609	EVQ21405R	SW, PRESET(DOWN)		RL701, 702	RSY0013M-0	RELAY	△
						HOLDER(S)	

Ref. No.	Part No.	Part Name & Description	Remarks	Ref. No.	Part No.	Part Name & Description	Remarks
SH601	FMN0194	FL HOLDER				JACK(S)	
		TRANSFORMER(S)					
PT701	RTP1N5B015	POWER TRANSFORMER	△ (E, EB, EG, GN)	JK101	RJH4202M	ANTENNA TERMINAL	(E, EB, EG)
PT701	RTP1N5G004	POWER TRANSFORMER	△ (GC)	JK101	RJH4405-1M	ANTENNA TERMINAL	(GC, GN)
				JK201	RJT065K15	CONNECTOR (15P)	
				JK301	RJD7S2XA-C	HEADPHONES JACK	
				JK351	SJT3213	CONNECTOR (2P)	
				JK501	RJR0054M	SPEAKER TERMINAL	
				JK502	SJF3068-6N	SURROUND SPEAKER TERMINAL	(E, EB, EG)
				JK502	SJF3068N	SURROUND SPEAKER TERMINAL	(GC, GN)
				JK701	SJS9236	AC INLET	△ (E, EB, EG, GC)
				JK701	SJSD16	AC INLET	△ (GN)
				JK702	SJS702-1	CONNECTOR (7P)	

Notes : * Capacity values are in microfarads (uF) unless specified otherwise, P=Pico-farads (pF) F=Farads (F)
* Resistance values are in ohms, unless specified otherwise, 1K=1,000 (OHM) , 1M=1,000k (OHM)

Ref. No.	Part No.	Values & Remarks	Ref. No.	Part No.	Values & Remarks	Ref. No.	Part No.	Values & Remarks
		RESISTORS	R129	ERDS2TJ473	1/4W 47K	R195	ERDS2TJ223	1/4W 22K
			R130, 131	ERDS2TJ102	1/4W 1K	R201, 202	ERDS2TJ222	1/4W 2.2K
			R132	ERDS2TJ103	1/4W 10K	R203, 204	ERDAS3G223T	1/4W 22K
R103	ERDS2TJ271	1/4W 270 E, EB, GC, GN	R133-137	ERDS2TJ102	1/4W 1K	R205, 206	ERDS2TJ104	1/4W 100K
R103	ERDS2TJ330	1/4W 33 EG	R138	ERDS2TJ103	1/4W 10K	R207, 208	ERDAS3G562T	1/4W 5.6K
R104	ERDS2TJ822	1/4W 8.2K	R139, 140	ERDS2TJ272T	1/4W 2.7K	R209, 210	ERDAS3G332T	1/4W 3.3K
R105	ERDS2TJ471	1/4W 470	R141, 142	ERDS2TJ103	1/4W 10K	R211, 212	ERDS2TJ222	1/4W 2.2K
R106	ERDS2TJ474	1/4W 470K	R143, 144	ERDS2TJ222	1/4W 2.2K	R213, 214	ERDS2TJ204	1/4W 200K
R107	ERDS2TJ331	1/4W 330	R145, 146	ERDS2TJ102	1/4W 1K E, EB, GC, GN	R215, 216	ERDS2TJ474	1/4W 470K
R108	ERDS2TJ474	1/4W 470K	R145, 146	ERDS2TJ821	1/4W 820 EG	R217, 218	ERDS2TJ102	1/4W 1K
R109	ERDS2TJ331	1/4W 330	R147, 148	ERDS2TJ474	1/4W 470K	R219, 220	ERDS2TJ331	1/4W 330
R110	ERDS2TJ102	1/4W 1K	R149	ERDS2TJ680T	1/4W 68	R221, 222	ERDS2TJ105T	1/4W 1M
R112	ERDS2TJ104	1/4W 100K	R151-154	ERDS2TJ104	1/4W 100K	R223, 224	ERDS2TJ332	1/4W 3.3K E, EB, EG
R113	ERDS2TJ103	1/4W 10K	R155	ERDS2TJ102	1/4W 1K	R223, 224	ERDS2TJ222	1/4W 2.2K GC, GN
R114	ERDS2TJ562	1/4W 5.6K	R156	ERDS2TJ105T	1/4W 1M	R225, 226	ERDS2TJ104	1/4W 100K
R115	ERDS2TJ561	1/4W 560	R157, 158	ERDS2TJ102	1/4W 1K	R227, 228	ERDS2TJ332	1/4W 3.3K
R116	ERDS2TJ102	1/4W 1K	R159	ERDS2TJ100	1/4W 10	R251, 252	ERDS2TJ102	1/4W 1K
R117	ERDS2TJ682T	1/4W 6.8K	R160, 161	ERDS2TJ331	1/4W 330	R253, 254	ERDS2EJ121	1/4W 120
R118	ERDS2TJ562	1/4W 5.6K	R162	ERDS2TJ152	1/4W 1.5K	R255	ERDS2TJ154	1/4W 150K
R119	ERDS2TJ392T	1/4W 3.9K E, EB, GC, GN	R163	ERDS2TJ331	1/4W 330	R256	ERDS2TJ105T	1/4W 1M
R119	ERDS2TJ822	1/4W 8.2K EG	R171, 172	ERDS2TJ102	1/4W 1K	R257	ERDS2TJ334	1/4W 330K
R120	ERDS2TJ473	1/4W 47K	R173	ERDS2TJ471	1/4W 470	R258	ERDS2TJ105T	1/4W 1M
R121	ERDS2TJ332	1/4W 3.3K	R175	ERDS2TJ102	1/4W 1K	R259	ERDS2TJ561	1/4W 560
R122	ERDS2TJ272T	1/4W 2.7K	R176	ERDS2TJ391	1/4W 390	R260	ERDS2TJ392T	1/4W 3.9K
R124	ERDS2TJ391	1/4W 390	R191	ERDS2TJ103	1/4W 10K	R281	ERDS2TJ102	1/4W 1K
R125, 126	ERDS2TJ472	1/4W 4.7K	R192	ERDS2TJ122	1/4W 1.2K	R282	ERDS2TJ561	1/4W 560
R127	ERDS2TJ103	1/4W 10K	R193	ERDS2TJ182	1/4W 1.8K	R291, 292	ERDS2TJ104	1/4W 100K
R128	ERDS2TJ820	1/4W 82	R194	ERDS2TJ122	1/4W 1.2K	R293, 294	ERDAS3G123T	1/4W 12K

Ref. No.	Part No.	Values & Remarks	Ref. No.	Part No.	Values & Remarks	Ref. No.	Part No.	Values & Remarks
R295, 296	ERDAS3G622T	1/4W 6.2K	R621	ERDS2TJ104	1/4W 100K	C109, 110	ECBT1C103NS5	16V 0.01U
R301, 302	ERDS2TJ562	1/4W 5.6K	R622	ERDS2TJ102	1/4W 1K	C111	ECEA1EKA4R7B	25V 4.7U
R303-306	ERDS2TJ563	1/4W 56K	R623	ERDS2TJ223	1/4W 22K	C112	ECBT1C103NS5	16V 0.01U
R307, 308	ERDS2TJ562	1/4W 5.6K	R624	ERDS2TJ393	1/4W 39K	C113	ECBT1H102KB5	50V 1000P
R309-312	ERDS2EJ121	1/4W 120	R625	ERDS2TJ564	1/4W 560K	C114	ECEA1HKA3R3B	50V 3.3U
R313, 314	ERDS2TJ102	1/4W 1K	R626-629	ERDS2TJ223	1/4W 22K	C115	ECEA1CKA100B	16V 10U
R315	ERDS2TJ334	1/4W 330K	R630, 631	ERDS2TJ332	1/4W 3.3K	C116	ECBT1C822MS5	16V 8200P
R316	ERDS2TJ105T	1/4W 1M	R632	ERDS2TJ103	1/4W 10K	C117	ECQB1H821JF3	50V 820P E, EB, GC, GN
R351	ERDS2TJ563	1/4W 56K	R634	ERDS2TJ223	1/4W 22K	C117	ECQP2A21JZT	100V 220P EG
R352	ERDS2TJ184T	1/4W 180K	R635	ERDS2TJ224T	1/4W 220K	C118, 119	ECFR1E103KR	25V 0.01U
R353	ERDS2TJ274	1/4W 270K	R636	ERDS2TJ104	1/4W 100K	C120, 121	ECEA1HKA010B	50V 1U
R354	ERDS2TJ102	1/4W 1K	R637	ERDS2TJ102	1/4W 1K	C122	ECEA1HKA2R2B	50V 2.2U
R355	ERDS2TJ103	1/4W 10K	R639	ERDS2TJ560T	1/4W 56	C123	ECEA1HKA010B	50V 1U
R356	ERDS2TJ332	1/4W 3.3K	R660-665	ERDS2TJ102	1/4W 1K	C124	ECBT1H102KB5	50V 1000P
R357	ERDS1FVJ390T	1/2W 39 △	R697	ERDS2TJ102	1/4W 1K	C125	ECBT1H150JC5	50V 15P
R358	ERDS2TJ220T	1/4W 22	R698	ERDS2TJ332	1/4W 3.3K	C126	ECBT1H473ZF5	50V 0.047U
R361	ERDS2TJ474	1/4W 470K	R699	ERDS2TJ102	1/4W 1K	C127	ECEA1CKA220B	16V 22U
R362	ERDS2TJ102	1/4W 1K	R701, 702	ERD2FCVJ4R7T	1/4W 4.7 △	C128	ECBT1C103NS5	16V 0.01U
R371	ERDS2TJ103	1/4W 10K	R703, 704	ERDS2TJ562	1/4W 5.6K	C129, 130	ECEA0JKA101B	6.3V 100U
R372	ERDS2TJ823T	1/4W 82K	R705, 706	ERGISJ471E	1W 470	C131	ECBT1C103NS5	16V 0.01U
R373	ERDS2TJ222	1/4W 2.2K	R707	ERDS2TJ680T	1/4W 68	C132	ECBT1H102KB5	50V 1000P
R374	ERDS2TJ823T	1/4W 82K	R708	ERDS2TJ562	1/4W 5.6K	C133	ECBT1H150JC5	50V 15P
R375	ERDS2TJ153	1/4W 15K	R709, 710	ERGISJ391E	1W 390	C134	ECBT1H180JC5	50V 18P
R398	ERDS2TJ332	1/4W 3.3K	R711, 712	ERGISJ331E	1W 330	C135, 136	ECBT1C822MS5	16V 8200P
R399	ERDS2TJ154	1/4W 150K	R713	ERDS1FVJ2R2T	1/2W 2.2 △	C137, 138	ECBT1H271KB5	50V 270P
R457	ERDS2TJ105T	1/4W 1M GC, GN	R714	ERGISJ681E	1W 680	C139, 140	ECFR1E562KR	25V 5600P E, EB, GC, GN
R459	ERDS2TJ272T	1/4W 2.7K GC, GN	R715	ERDS2TJ153	1/4W 15K	C139, 140	ECFR1E822KR	25V 8200P EG
R471, 472	ERDS2TJ121	1/4W 120 GC, GN	R716	ERDS2TJ102	1/4W 1K	C141-144	ECEA1HKA010B	50V 1U
R501, 502	ERDS2TJ222	1/4W 2.2K	R717	ERDS2TJ103	1/4W 10K	C145	ECBT1H220JC5	50V 22P
R503-506	ERDS2TJ563	1/4W 56K	R799	ERDS2TJ103	1/4W 10K	C146	ECBT1H331KB5	50V 330P
R507, 508	ERDS2TJ272T	1/4W 2.7K	R801	ERDS2TJ102	1/4W 1K	C147	ECBT1H102KB5	50V 1000P
R509, 510	ERDS2TJ102	1/4W 1K	R803	ERDS2TJ103	1/4W 10K	C148	ECBT1C103NS5	16V 0.01U
R511	ERDS2TJ334	1/4W 330K	R805	ERDS2TJ562	1/4W 5.6K	C149	ECBT1H104ZF5	50V 0.1U
R512	ERDS2TJ154	1/4W 150K △	R806	ERDS2TJ392T	1/4W 3.9K GC, GN	C151	ECEA1HKA010B	50V 1U
R513	ERDS2TJ684	1/4W 680K △	R808	ERDS2TJ392T	1/4W 3.9K	C152	ECR1H103ZF5	50V 0.01U
R514	ERD25FJ470	1/4W 47 △	R809, 810	ERDS2TJ272T	1/4W 2.7K	C153	ECEA1AKA101B	10V 100U
R515, 516	ERDS1FVJ100T	1/2W 10 △	R811	ERDS2TJ221	1/4W 220	C155, 156	ECBT1E103ZF	25V 0.01U
R517, 518	ERD25FVJ100T	1/4W 10 △	R812	ERDS2TJ332	1/4W 3.3K	C157, 158	ECBT1H101KB5	50V 100P
R551, 552	ERDS2TJ223	1/4W 22K GC, GN	R820-822	ERDS2TJ272T	1/4W 2.7K	C171	ECBT1C103NS5	16V 0.01U
R553, 554	ERDS2TJ182	1/4W 1.8K GC, GN	R1601	ERDS2TJ223	1/4W 22K	C172	ECBT1H331KB5	50V 330P
R555, 556	ERDS2TJ102	1/4W 1K GC, GN	R1602	ERDS2TJ473	1/4W 47K	C173	ECEA1CKA220B	16V 22U
R557, 558	ERDS1FVJ4R7T	1/2W 4.7 △GC, GN	R1603	ERDS2TJ223	1/4W 22K	C174	ECEA1CKA100B	16V 10U E, EB, GC, GN
R559	ERDS2TJ271	1/4W 270 GC, GN	R1604, 1605	ERDS2TJ102	1/4W 1K	C174	ECEA1CKA101B	16V 100U EG
R560, 561	ERDS2TJ103	1/4W 10K GC, GN				C181	ECBT1H471KB5	50V 470P EG
R571	ERDS2TJ823T	1/4W 82K				C201, 202	ECBT1H101KB5	50V 100P
R572	ERDS2TJ124T	1/4W 120K				C203, 204	ECQB1H393JF3	50V 0.039U
R573	ERDS2TJ563	1/4W 56K				C205, 206	ECQB1H333JF3	50V 0.033U
R611	ERDS2TJ470	1/4W 47				C207, 208	ECBT1H471KB5	50V 470P
R613, 614	ERDS2TJ101	1/4W 100 △				C209, 210	ECEA1HKA3R3B	50V 3.3U
R615	ERDS2TJ2R2T	1/4W 2.2 △				C211, 212	ECBT1H101KB5	50V 100P
R616-619	ERDS2TJ104	1/4W 100K				C213, 214	ECQB1H822JF3	50V 8200P E, EB, EG
R620	ERDS2TJ221	1/4W 220				C213, 214	ECQB1H103JF3	50V 0.01U GC, GN

Ref. No.	Part No.	Values & Remarks	Ref. No.	Part No.	Values & Remarks
C215, 216	ECBT1H101KB5	50V 100P	C612	ECBT1E223ZF	25V 0.022U
C217, 218	ECBT1H151KB5	50V 150P	C620	ECEA1HKS010	50V 1U Δ
C219, 220	ECEA1CKA100B	16V 10U	C621, 622	ECBT1H200JC5	50V 20P
C221, 222	ECQB1H333JF3	50V 0.033U	C698, 699	ECBT1E103ZF	25V 0.01U
C251	ECEA0JKA221B	6.3V 220U	C701, 702	ECA1HM332B	50V 3300U E, EB, EG
C252	ECEA1CKA100B	16V 10U	C701, 702	ECEA45V472YB	45V 4700U GC, GN
C281-287	ECBT1E103ZF	25V 0.01U	C703, 704	ECEA1CKA330B	16V 33U
C291, 292	ECQB1H223JF3	50V 0.022U	C705, 706	ECKR1H103ZF5	50V 0.01U
C293, 294	ECBT1H101KB5	50V 100P	C707	ECA1HM221B	50V 220U
C301, 302	ECEA1HKA3R3B	50V 3.3U	C708	ECEA1CKA100B	16V 10U
C303, 304	ECBT1H101KB5	50V 100P	C709	ECBT1E103ZF	25V 0.01U
C305, 306	ECBT1H330J5	50V 33P	C710	ECA1HAP330B	50V 33U
C307, 308	ECEA1HKA3R3B	50V 3.3U	C711	ECQE1104KF3	100V 0.1U Δ
C309	ECEA1HKA010B	50V 1U	C712	ECBT1E223ZF	25V 0.022U
C351	ECEA1CKA100B	16V 10U	C714, 715	ECKR1H103ZF5	50V 0.01U Δ
C352	ECBT1E223ZF	25V 0.022U	C801, 802	ECBT1H470J5	50V 47P
C353	ECEA1HKA2R2B	50V 2.2U	C803	ECBT1H104ZF5	50V 0.1U
C361	ECEA1CN470SB	16V 47U Δ	C810	ECBT1H470J5	50V 47P
C371	ECEA0JKA221B	6.3V 220U	C811	ECBT1E103ZF	25V 0.01U
C381, 382	ECBT1E103ZF	25V 0.01U	C821, 822	ECBT1H220J5	50V 22P
C397, 398	ECBT1E103ZF	25V 0.01U	C905, 906	ECBT1H101KB5	50V 100P
C451	ECEA1CKA100B	16V 10U GC, GN	C907, 908	ECBT1E223ZF	25V 0.022U
C501, 502	ECA1HAP3R3B	50V 3.3U	C911	ECKR1H102ZF5	50V 1000P Δ
C503, 504	ECBT1H331KB5	50V 330P	C1101, 1102	ECBT1E223ZF	25V 0.022U
C505, 506	ECBT1H6R8K5	50V 6.8P	C1103, 1104	ECBT1H102KB5	50V 1000P E, EB, EG
C507, 508	ECBT1H102KB5	50V 1000P	C1105, 1106	ECBT1H102KB5	50V 1000P
C509, 510	ECA1HAP3R3B	50V 3.3U	C1107, 1108	ECBT1E223ZF	25V 0.022U GC, GN
C511, 512	ECBT1H821KB5	50V 820P	C1111	ECBT1H102KB5	50V 1000P GC, GN
C513	ECA1HAP330B	50V 33U			
C514	ECA2AAP100B	100V 10U			
C515, 516	ECBT1H104ZF5	50V 0.1U			
C551	ECBT1C472KR5	16V 4700P GC, GN			
C552	ECBT1C222KR5	16V 2200P GC, GN			
C553, 554	ECEA1HKA3R3B	50V 3.3U GC, GN			
C555	ECEA1HKA2R2B	50V 2.2U GC, GN			
C556	ECEA1HKA010B	50V 1U GC, GN			
C557, 558	ECA1VM101B	35V 100U GC, GN			
C559, 560	ECQV1H473JM3	50V 0.047U GC, GN			
C561	ECA1EM221B	25V 220U GC, GN			
C562	ECEA1HRN010B	50V 1U ΔGC, GN			
C563	ECQV1H104JM3	50V 0.1U GC, GN			
C571	ECEA0JKA101B	6.3V 100U			
C599	ECBT1C103MS5	16V 0.01U E, EB, EG			
C601	ECEA0JU102	6.3V 1000U			
C602	ECBT1E223ZF	25V 0.022U			
C603	ECEA1CKS100L	16V 10U			
C604	ECEA1VKA330B	35V 33U Δ			
C605	ECEA1VKA330B	35V 33U			
C607	ECEA1HKS010	50V 1U			
C608	ECEA1HRAR22B	50V 0.22U			
C609, 610	ECBT1E103ZF	25V 0.01U			
C611	ECBT1H102KB5	50V 1000P			

Ref. No.	Part No.	Part Name & Description	Remarks	Ref. No.	Part No.	Part Name & Description	Remarks
		CABINET PARTS				PACKING MATERIALS	
1	RHD30007	SCREW		P1	RPG1410	PACKING CASE (SYSTEM)	(E, EG)
2	RKM0202A-1K	CABINET		P1	RPG1411	PACKING CASE (SYSTEM)	(EB)
3	XTBS3+8JFZ1	SCREW		P1	RPG1454	PACKING CASE (SYSTEM)	(GC)
4	RWJ1808110XX	FLAT CABLE (8P)		P1	RPG1412	PACKING CASE (SYSTEM)	(GN)
5	RGW0157-K	KNOB, MAIN VOLUME		P2	RPG1314	PACKING CASE (CD/PROCESSOR)	
7	RFKJACH550PK	BOTTOM BOARD ASS'Y	(E, EB, EG, GN)	P3	RPG1312	PACKING CASE (AMPLIFIER)	
7	RFKJACH550GC	BOTTOM BOARD ASS'Y	(GC)	P4	RPG1313	PACKING CASE (DECK)	
7-1	RKA0055-N	FOOT		P5	RPN0627	PAD (CD/PROCESSOR)	
8	RFKHACH750EK	REAR GRILL ASS'Y	(E)	P6	RPN0625	PAD (AMPLIFIER)	
8	RFKHACH750EB	REAR GRILL ASS'Y	(EB)	P7	RPN0626	PAD (DECK)	
8	RFKHACH750EG	REAR GRILL ASS'Y	(EG)	P8	RPQF0047	ACCESSORY BOX	
8	RFKHACH750GC	REAR GRILL ASS'Y	(GC)	P9	RPQ0244	SPACER	
8	RFKHACH750GN	REAR GRILL ASS'Y	(GN)	P10	XZB45X50A01Z	PROTECTION COVER	
9	RMCO158	TRANSISTOR HOLDER		P11	XZB22X20C03	PROTECTION COVER	
10	RMCO182	EARTH PLATE				ACCESSORIES	
11	RMNO190	HOLDER(A)		A1	RAK-SC709WH	REMOTE CONTROL TRANSMITTER	
12	RMNO191-1	HOLDER(B)		A1-1	RKK0020-K	BATTERY COVER	
13	RMNO194	FL HOLDER		A2	RFKSACH950EK	INSTRUCTIONS MANUAL	(E)
14	RFKGACH750EK	FRONT PANEL ASS'Y		A2	RFKSACH950EB	INSTRUCTIONS MANUAL	(EB)
15	RGU0796-K	BUTTON, INPUT SELECTOR etc.		A2	RFKSACH950EG	INSTRUCTIONS MANUAL	(EG)
16	RGU0797-K	BUTTON, POWER etc		A2	RFKSACH950GC	INSTRUCTIONS MANUAL	(GC)
17	XTBS26+8J	SCREW		A2	RFKSACH950GN	INSTRUCTIONS MANUAL	(GN)
18	XTWS3+10T	SCREW		A3	RQ0013	WARRANTY CARD	(E, EB, EG)
19	SHE187-2	P. C. B. SPACER		A3	RQX7433ZA	WARRANTY CARD	(GN)
20	SNE4021-1	NUT		A4	RQCBO169	SERVICE CENTER LIST	
21	XTBS3+8JFZ1	SCREW		A5	REX0462	FLAT CABLE (15P)	
22	XTB3+12JFZ	SCREW		A6	RJAD019-2K	AC POWER SUPPLY CORD	Δ (E, EG, GC)
23	XTB3+20JFZ	SCREW		A6	VJA0733	AC POWER SUPPLY CORD	Δ (EB)
24	XTB3+8JFZ	SCREW		A6	SJA173	AC POWER SUPPLY CORD	Δ (GN)
25	XTW3+15T	SCREW		A7	RSAD007	FM INDOOR ANTENNA	(E, EB, EG)
26	XTW3+8T	SCREW		A7	RSAD006	FM INDOOR ANTENNA	(GC, GN)
27	RMNO195	FL SPACER		A8	SPB1163T	LW/MW LOOP ANTENNA	
28	RMQ0260	HOLDER(L)		A8-1	SMA233-1M	ANTENNA HOLDER	
29	RMQ0261	HOLDER(R)		A8-2	XTN3+10AFZ	SCREW	
31	RMNO215	FAN ANGLE		A9	SWXS257M	SPEAKER CORD	
32	SYE1128-2	FAN ASS'Y		A10	RJL1P001B25	SURROUND SPEAKER CORD	(GC, GN)
32-1	SHE232	FAN		A11	SJP9009	ATTACHMENT PLUG	Δ (EB)
32-2	SUS271	SPRING		A12	SJP5213-2	POWER PLUG ADAPTOR	Δ (GC)
32-3	SHE233-1	FAN CASE					
32-4	MDN-4RB4MRC	MOTOR					
32-5	SHE234	CAP					
32-6	SJT783	TERMINAL					
32-7	SJSS215	CONNECTOR (2P)					
33	RMCO197	EARTH PLATE	(EG)				

PACKAGING

