

(For United Kingdom)

("EB" area code model only)

For your safety, please read the following text carefully.

This appliance is supplied with a moulded three pin mains plug for your safety and convenience.

A 5-ampere fuse is fitted in this plug.

Should the fuse need to be replaced please ensure that the replacement fuse has a rating of 5-ampere and that it is approved by ASTA or BSI to BS1362.

Check for the ASTA mark  or the BSI mark  on the body of the fuse.

If the plug contains a removable fuse cover you must ensure that it is refitted when the fuse is replaced.

If you lose the fuse cover the plug must not be used until a replacement cover is obtained.

A replacement fuse cover can be purchased from your local dealer.

CAUTION!

IF THE FITTED MOULDED PLUG IS UNSUITABLE FOR THE SOCKET OUTLET IN YOUR HOME THEN THE FUSE SHOULD BE REMOVED AND THE PLUG CUT OFF AND DISPOSED OF SAFELY.

THERE IS A DANGER OF SEVERE ELECTRICAL SHOCK IF THE CUT OFF PLUG IS INSERTED INTO ANY 13-AMPERE SOCKET.

If a new plug is to be fitted please observe the wiring code as shown below.

If in any doubt please consult a qualified electrician.

IMPORTANT

The wires in this mains lead are coloured in accordance with the following code:

Blue: Neutral, Brown: Live.

As these colours may not correspond with the coloured markings identifying the terminals in your plug, proceed as follows:

The wire which is coloured Blue must be connected to the terminal which is marked with the letter N or coloured Black or Blue.

The wire which is coloured Brown must be connected to the terminal which is marked with the letter L or coloured Brown or Red.

WARNING: DO NOT CONNECT EITHER WIRE TO THE EARTH TERMINAL WHICH IS MARKED WITH THE LETTER E, BY THE EARTH SYMBOL  OR COLOURED GREEN OR GREEN/YELLOW.

THIS PLUG IS NOT WATERPROOF - KEEP DRY.

Before use

Remove the connector cover.

How to replace the fuse

The location of the fuse differ according to the type of AC mains plug (figures A and B). Confirm the AC mains plug fitted and follow the instructions below. Illustrations may differ from actual AC mains plug.

1. Open the fuse cover with a screwdriver.

Figure A

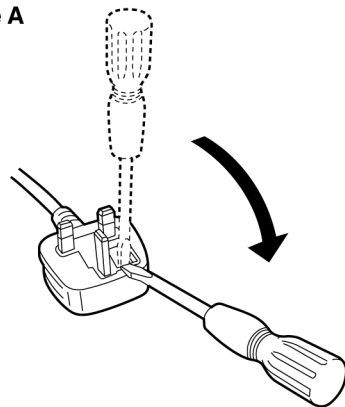
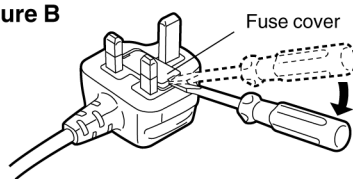

Figure B



2. Replace the fuse and close or attach the fuse cover.

Figure A

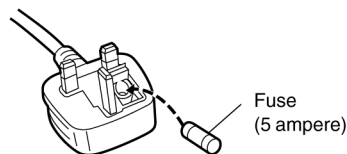
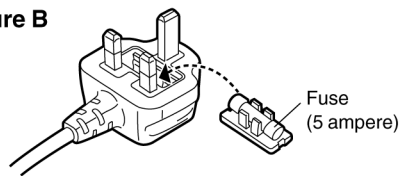
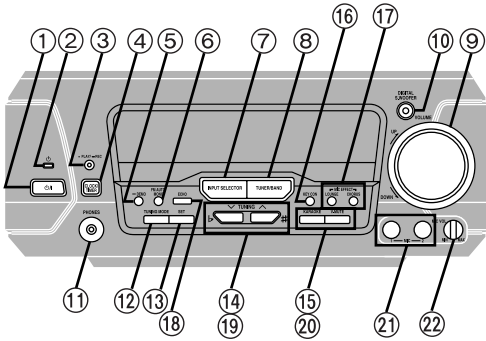

Figure B





- ① **Standby/on switch (⏻/⏻)**
Press to switch the unit from on to standby mode or vice versa. In standby mode, the unit is still consuming a small amount of power.
- ② **Standby indicator (⏻)**
When the unit is connected to the AC mains supply, this indicator lights up in standby mode and goes out when the unit is turned on.
- ③ **Play timer/record timer button and indicator (⏻/⏻)**
- ④ **Clock/timer button (CLOCK/TIMER)**
- ⑤ **Demo button (-DEMO)**
- ⑥ **FM mode button (FM AUTO/MONO)**
- ⑦ **Source input button (INPUT SELECTOR)**
- ⑧ **Tuner/band button (TUNER/BAND)**
- ⑨ **Digital super woofer button and indicator (DIGITAL S.WOOFER)**
- ⑩ **Volume control (VOLUME)**
- ⑪ **Headphone jack (PHONES)**
- ⑫ **Tuning mode button (TUNING MODE)**
- ⑬ **Set button (SET)**

For the United Kingdom, Continental Europe and Russia

- ⑭ **Tuning buttons (v, ^ TUNING)**
- ⑮ **RDS display mode button (RDS, PS-DISP MODE-PTY)**

For areas except the United Kingdom, Continental Europe and Russia

- ⑯ **Key control button (KEY CON)**
- ⑰ **MIC effect buttons (MIC EFFECT, LOUNGE, CHORUS)**
- ⑱ **Echo button (ECHO)**
- ⑲ **Tuning, Key up/down buttons (v, ^ TUNING, b, #)**
- ⑳ **KARAOKE, Voice mute buttons (KARAOKE, V.MUTE)**
- ㉑ **Microphone jacks (1-MIC-2)**
- ㉒ **Microphone volume control (MIC VOL)**

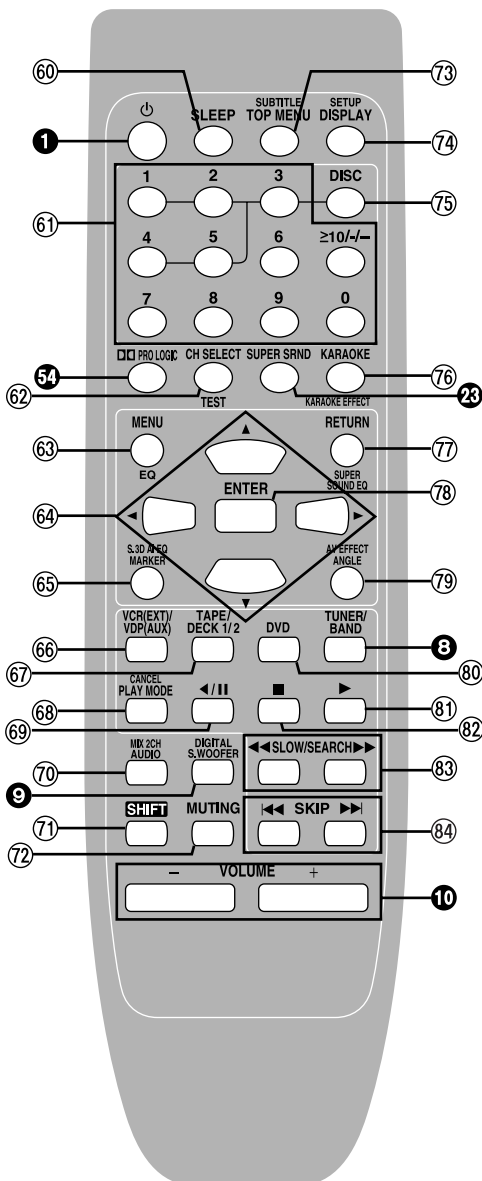

Buttons ①, ③, ⑨, ⑩, ⑮ and ⑳ function in the same way as the controls on the main unit.

- ⑥① **Sleep timer button (SLEEP)**
- ⑥② **Numbered buttons (1-9, 0, ≥10/--)**
- ⑥③ **Channel select, Test signal button (CH SELECT, TEST)**
- ⑥④ **Menu, EQ button (MENU, EQ)**
- ⑥⑤ **Cursor buttons (◀, ▶, ▲, ▼)**
- ⑥⑥ **Marker, Super 3D AI EQ button (MARKER, S.3D AI EQ)**
- ⑥⑦ **Input select button [VCR (EXT)/VDP (AUX)]**
- ⑥⑧ **Tape select, deck 1/deck 2 select button (TAPE/DECK 1/2)**
- ⑥⑨ **Play mode, Cancel button (PLAY MODE, CANCEL)**
- ⑦① **Disc pause, Tape reverse play button (◀/||)**
- ⑦② **Audio select, 2 channel down mixing button (AUDIO, MIX 2CH)**
- ⑦③ **Shift button (SHIFT)**
To operate functions labeled in orange, press [SHIFT] and then the corresponding button at the same time.
- ⑦④ **Muting button (MUTING)**
- ⑦⑤ **Top menu, Subtitle select button (TOP MENU, SUBTITLE)**
- ⑦⑥ **GUI display, Initial setting button (DISPLAY, SETUP)**
- ⑦⑦ **Disc button (DISC)**
- ⑦⑧ **Except for the United Kingdom, Continental Europe and Russia**
Karaoke, Karaoke effect button (KARAOKE, KARAOKE EFFECT)
- ⑦⑨ **Return, Super sound EQ button (RETURN, SUPER SOUND EQ)**
- ⑦⑩ **Enter button (ENTER)**
- ⑦⑪ **Angle select, AV effect button (ANGLE, AV EFFECT)**
- ⑦⑫ **DVD button (DVD)**
- ⑦⑬ **Disc play, Tape forward play button (▶)**
- ⑦⑭ **Disc stop, Tape stop button (■)**
- ⑦⑮ **Disc slow/search buttons (◀◀, ▶▶ SLOW/SEARCH)**
- ⑦⑯ **Disc skip buttons (|◀◀, ▶▶| SKIP)**

Z101 TUNER UNIT (RAN0005EM-2)

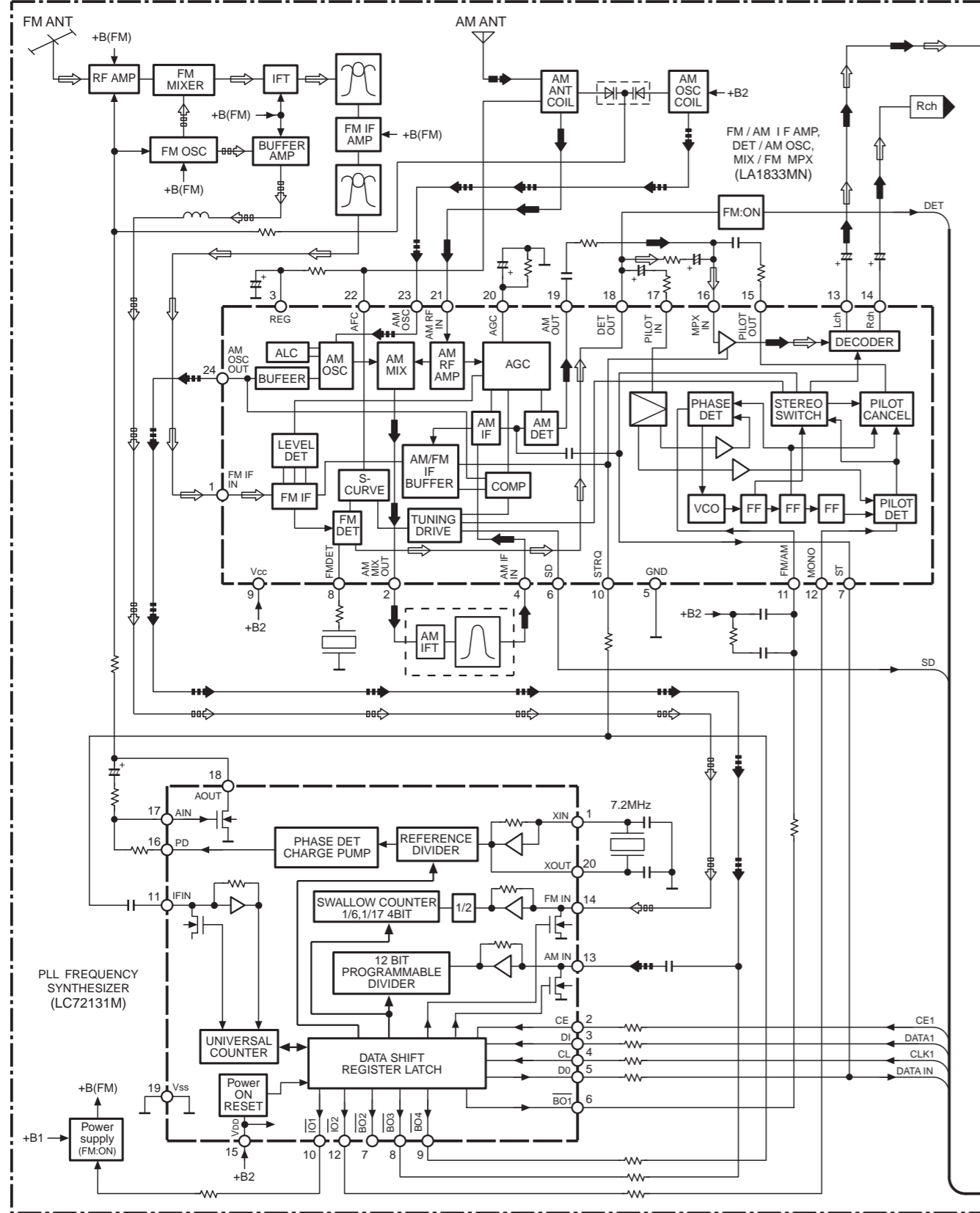

To SOUND PROCESSOR (SH-DV280) BLOCK DIAGRAM

- 1 TUNER L/C
- 2 TUNER Rch
- 3 A.GND
- 4 Lch IN
- 5 Rch IN
- 6 +B(10V)
- 7 SUR L
- 8 SUR R
- 9 S.W
- 10 MIC
- 11 -(10V)
- 12 V.GND
- 13 D.GND
- 14 CE/REQ
- 15 CLK
- 16 DATA
- 17 CT.GND
- 18 SH FL1
- 19 SH FL2
- 20 SYNC

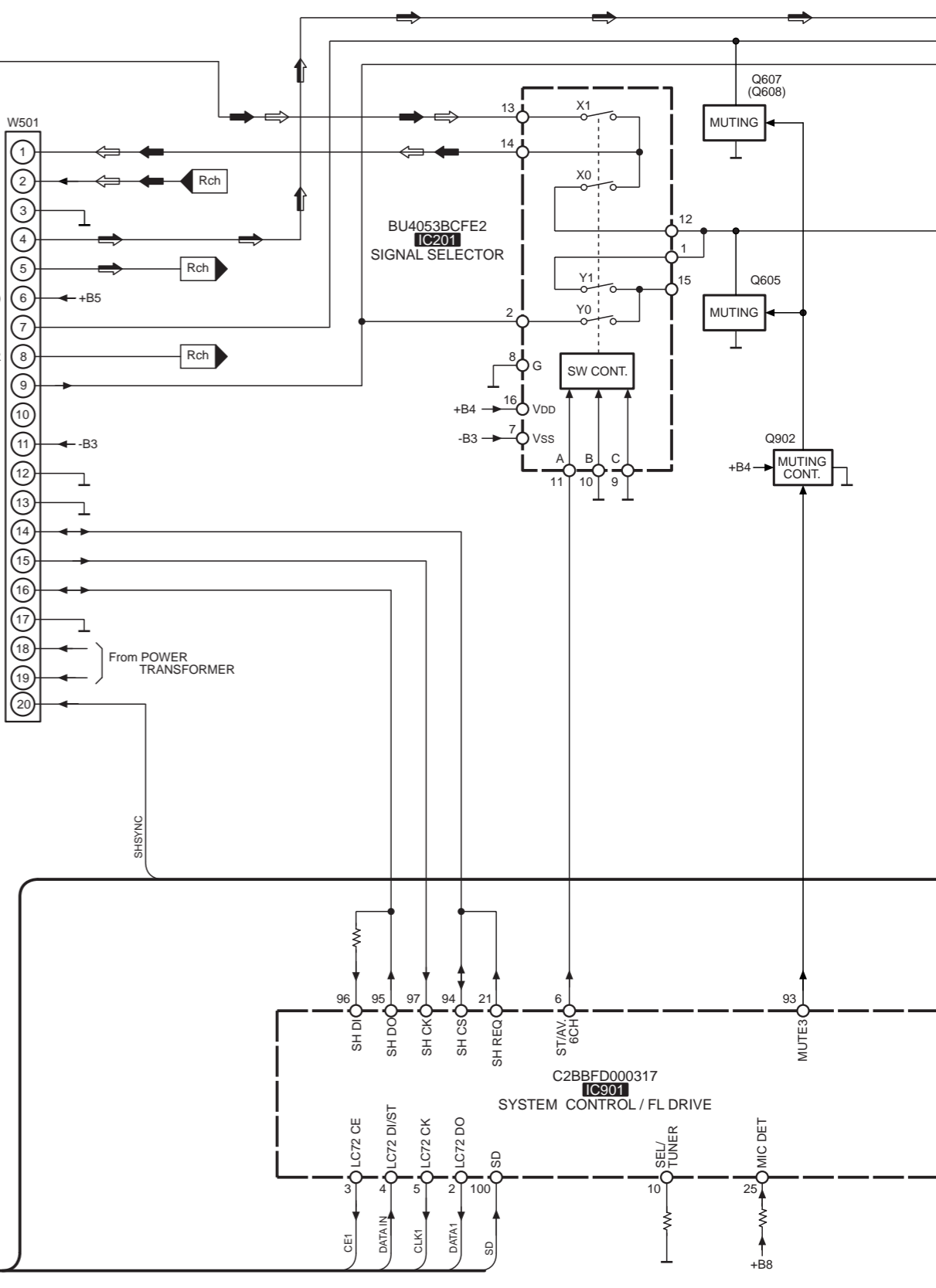

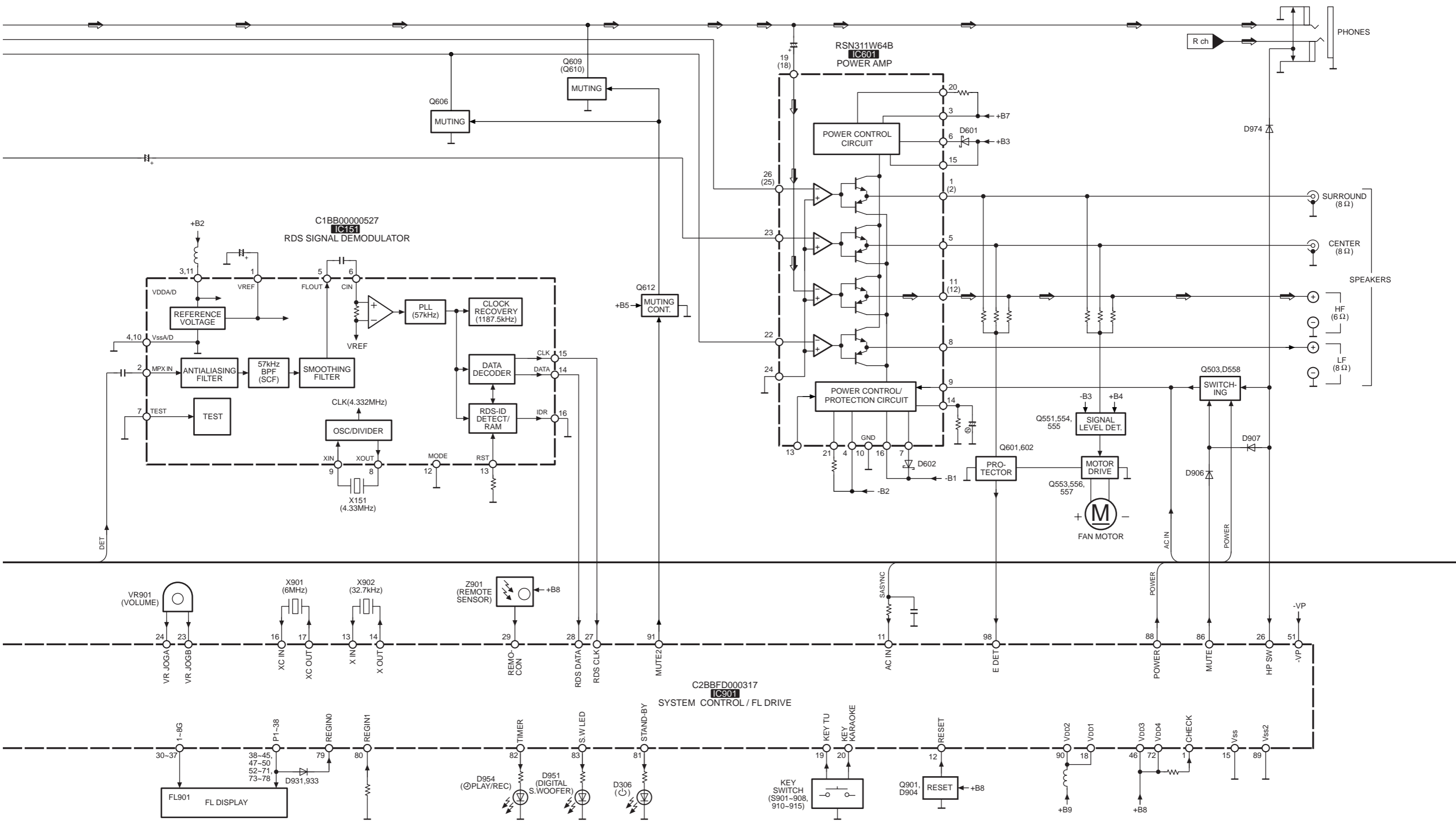

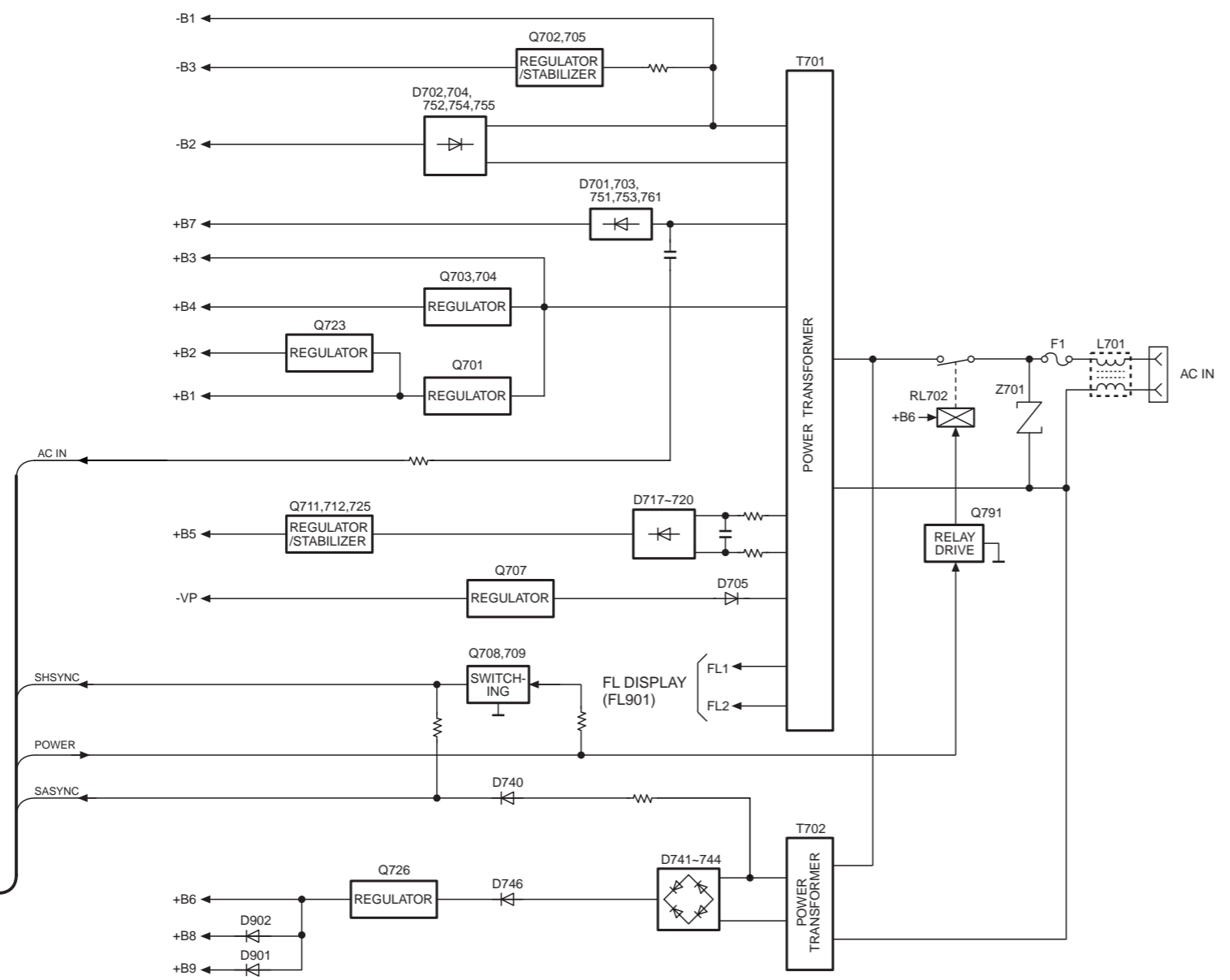

NOTES :

- SIGNAL LINE
- ◁ : FM SIGNAL
- ▶ : AM SIGNAL
- ◁▷ : FM OSC SIGNAL
- ▶▷ : AM OSC SIGNAL
- ◁▷▶ : AUDIO SIGNAL
- () indicates pin No. Right channel.

A OPERATION P.C.B.

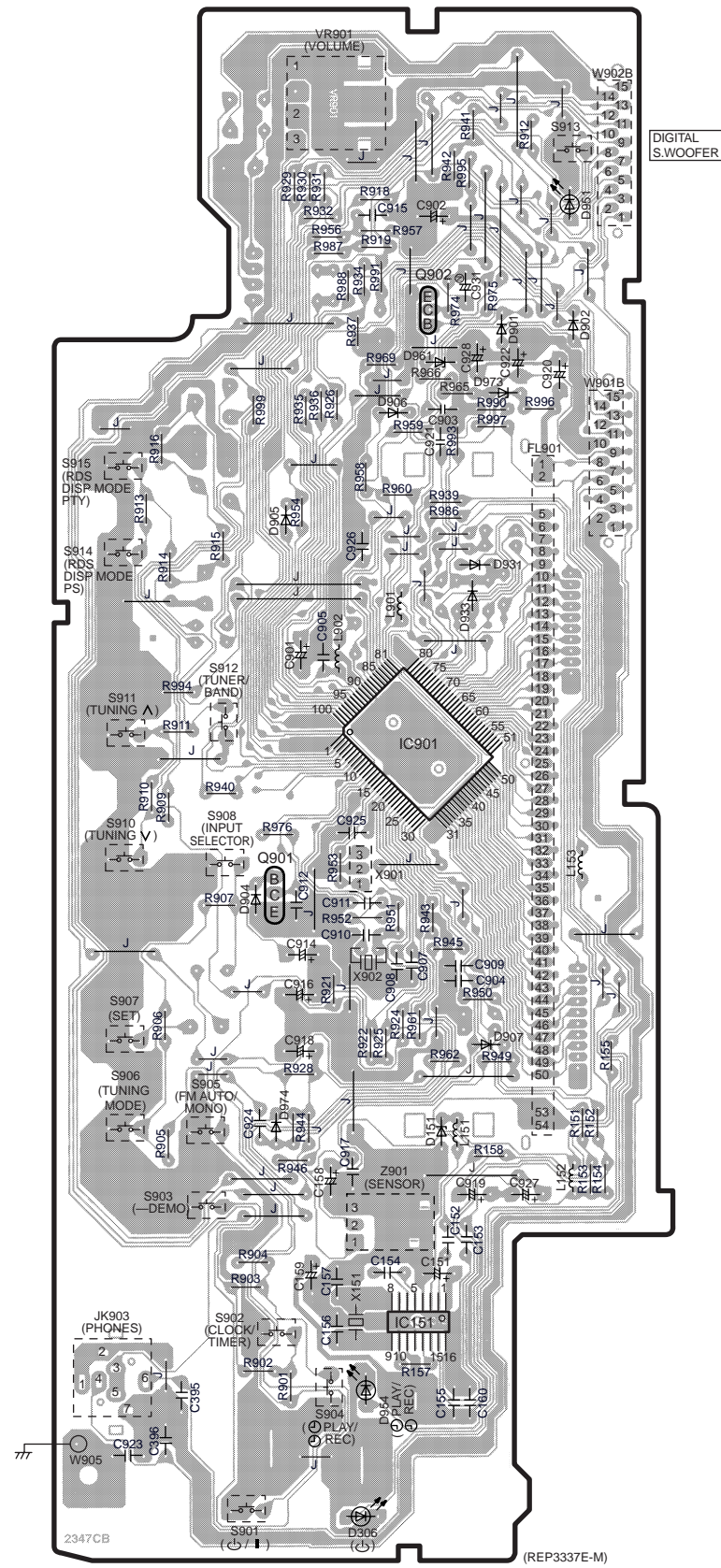

B MAIN P.C.B.

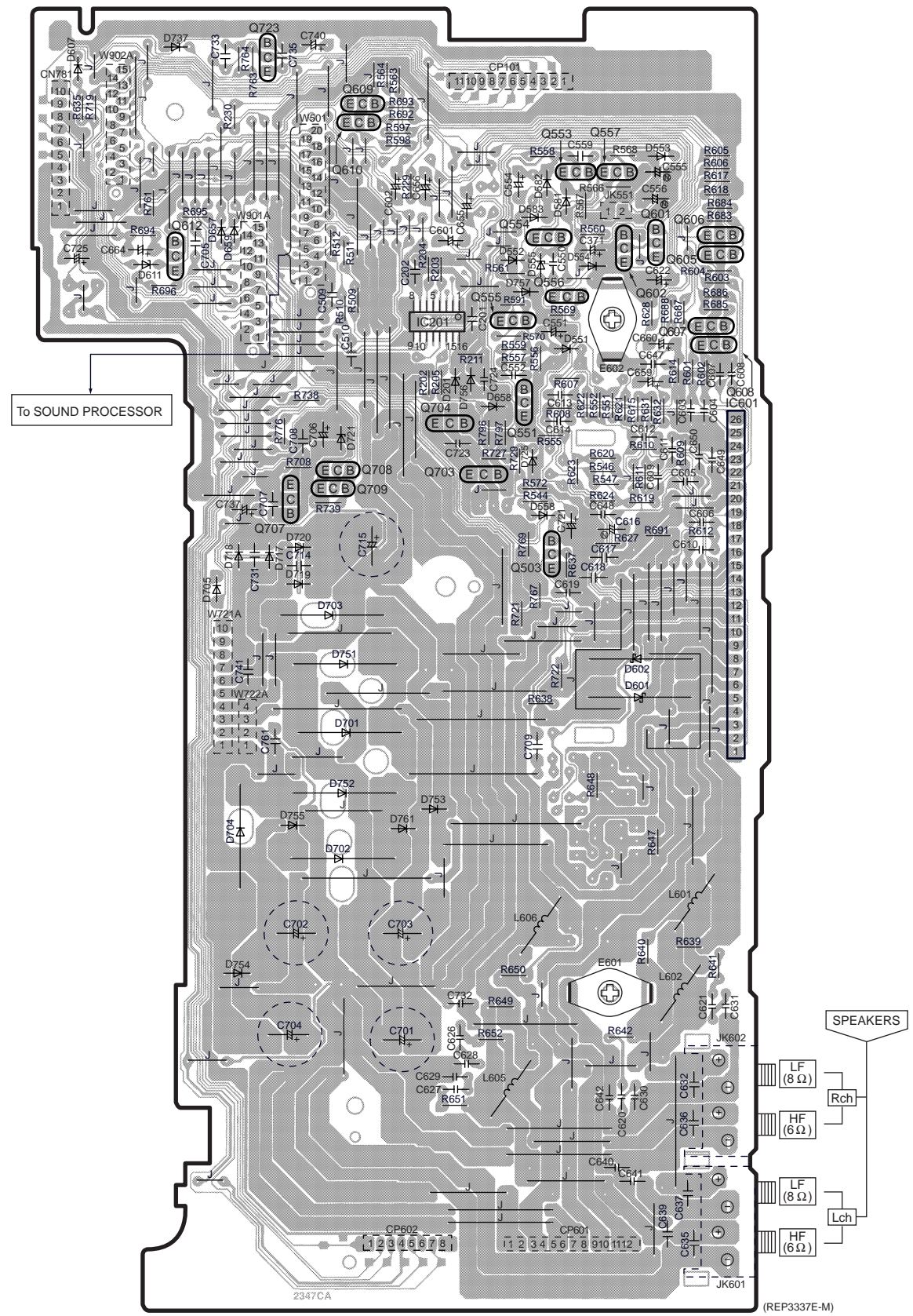

Note: This printed circuit board diagram may be modified at any time with the development of new technology.

D AC IN P.C.B.

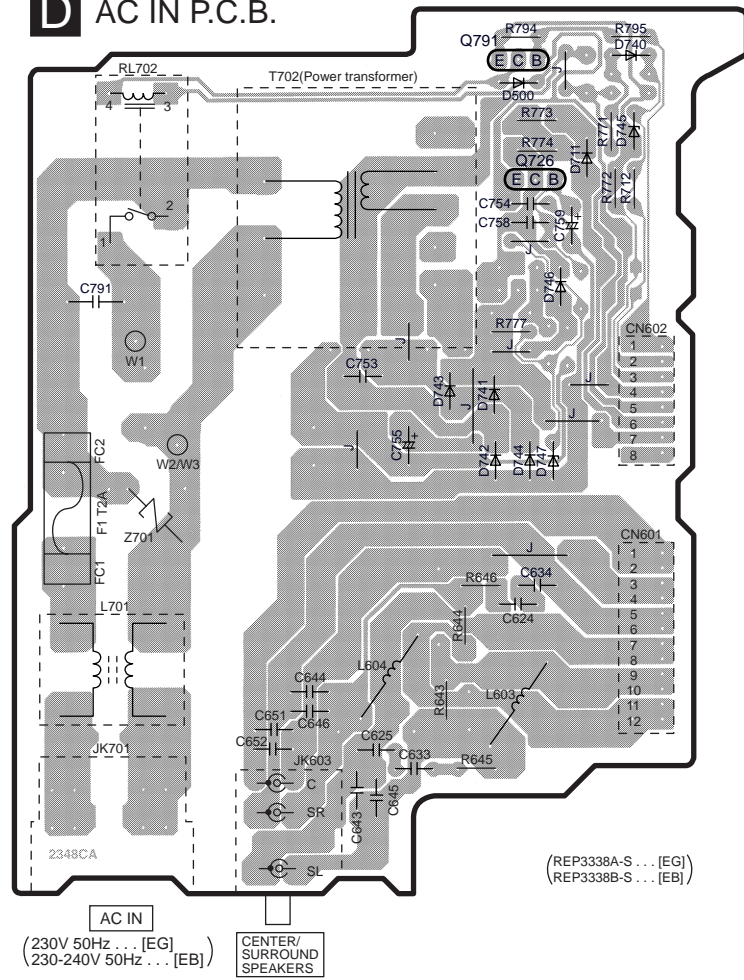

E POWER TRANSFORMER
(A) P.C.B.

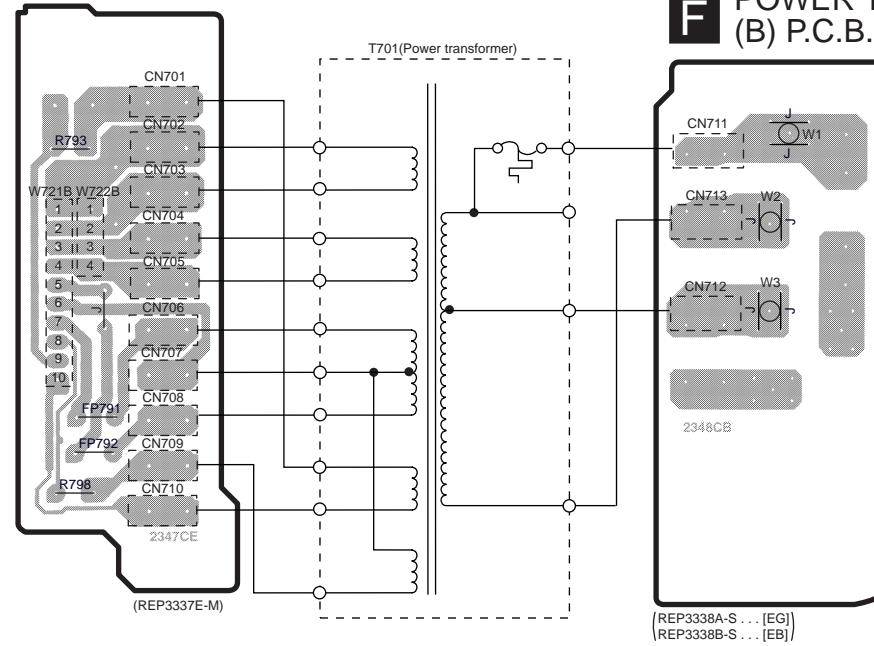

F POWER TRANSFORMER
(B) P.C.B.

C POWER SUPPLY P.C.B.

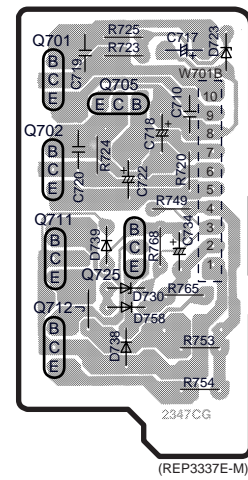

A OPERATION CIRCUIT

NOTE: The number which noted at the connectors on the schematic diagram as "SCHEMATIC DIAGRAM-1" or "SCHEMATIC DIAGRAM-2" indicates the schematic diagram serial number located on the left corner in the schematic diagram.

→ : POSITIVE VOLTAGE LINE - - - - - : NEGATIVE VOLTAGE LINE ⇨ : AUDIO SIGNAL LINE

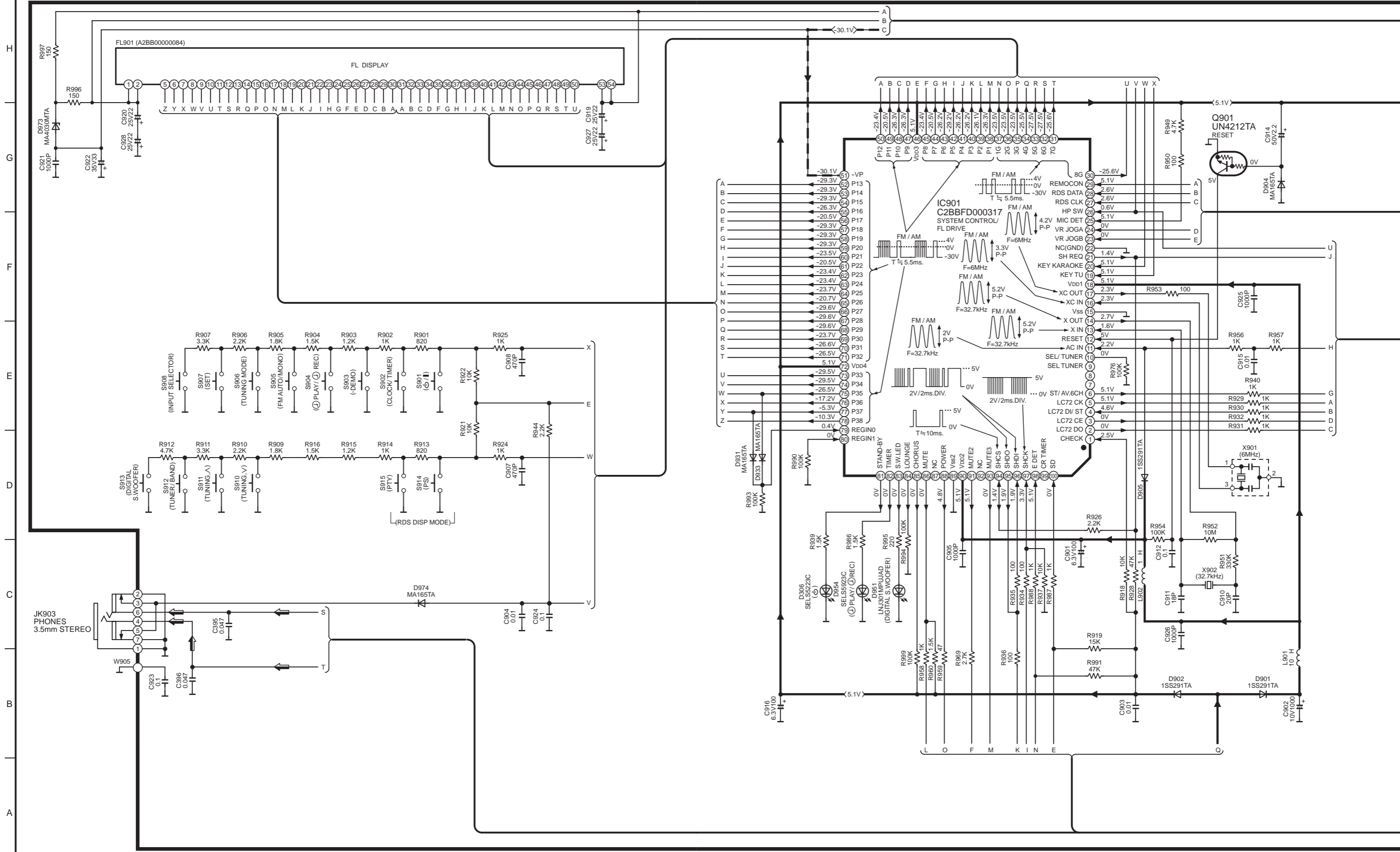

B MAIN CIRCUIT

— : POSITIVE VOLTAGE LINE
 - - - : NEGATIVE VOLTAGE LINE
 ⇨ : AUDIO SIGNAL LINE

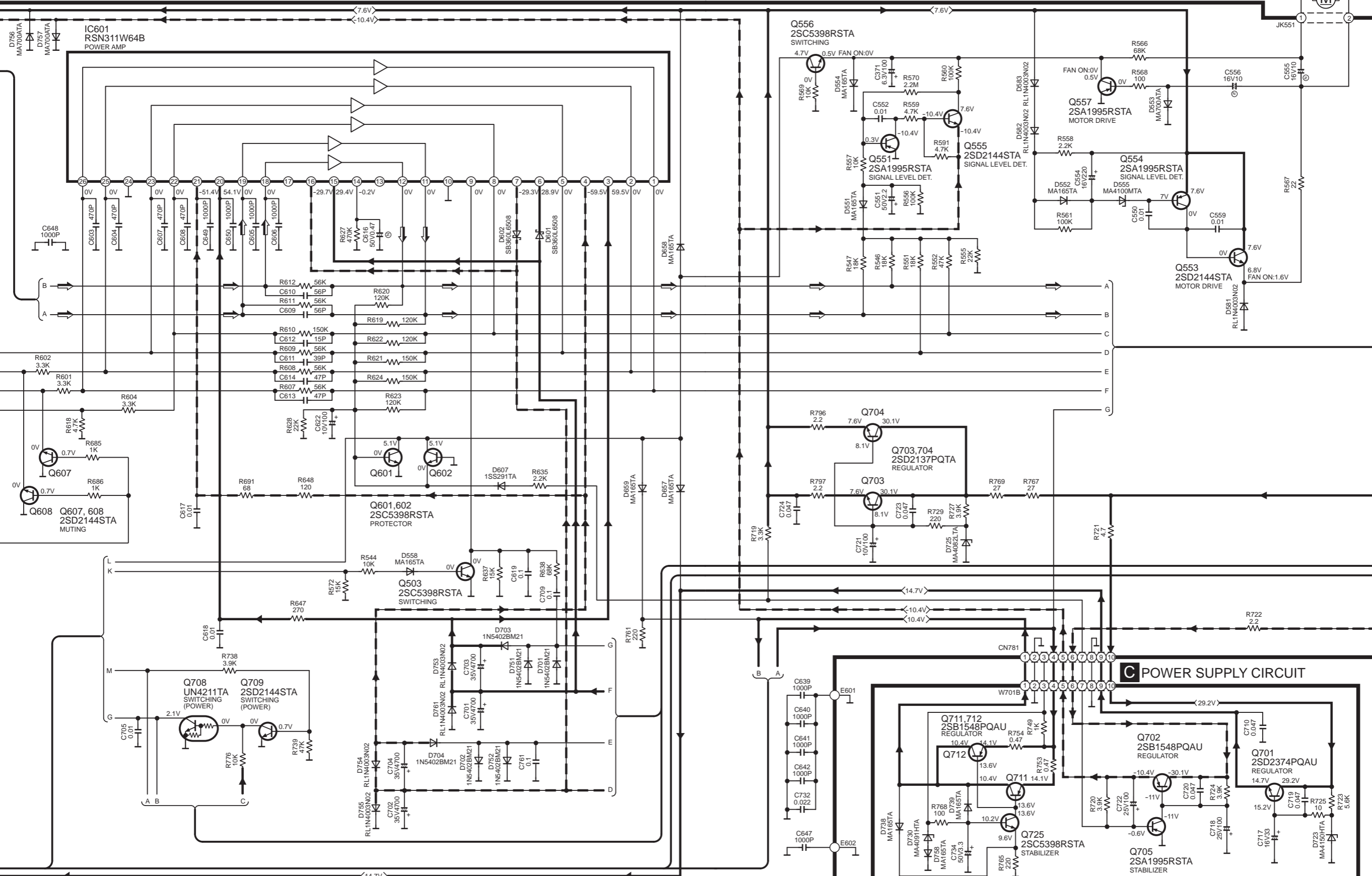

C POWER SUPPLY CIRCUIT

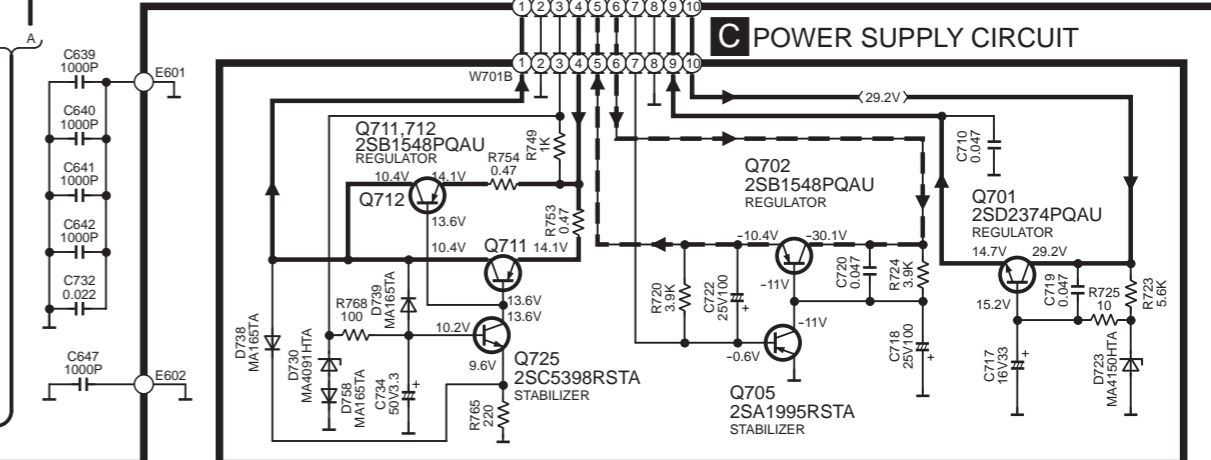

B MAIN CIRCUIT

→ : POSITIVE VOLTAGE LINE
 - - - - - : NEGATIVE VOLTAGE LINE
 ⇨ : AUDIO SIGNAL LINE

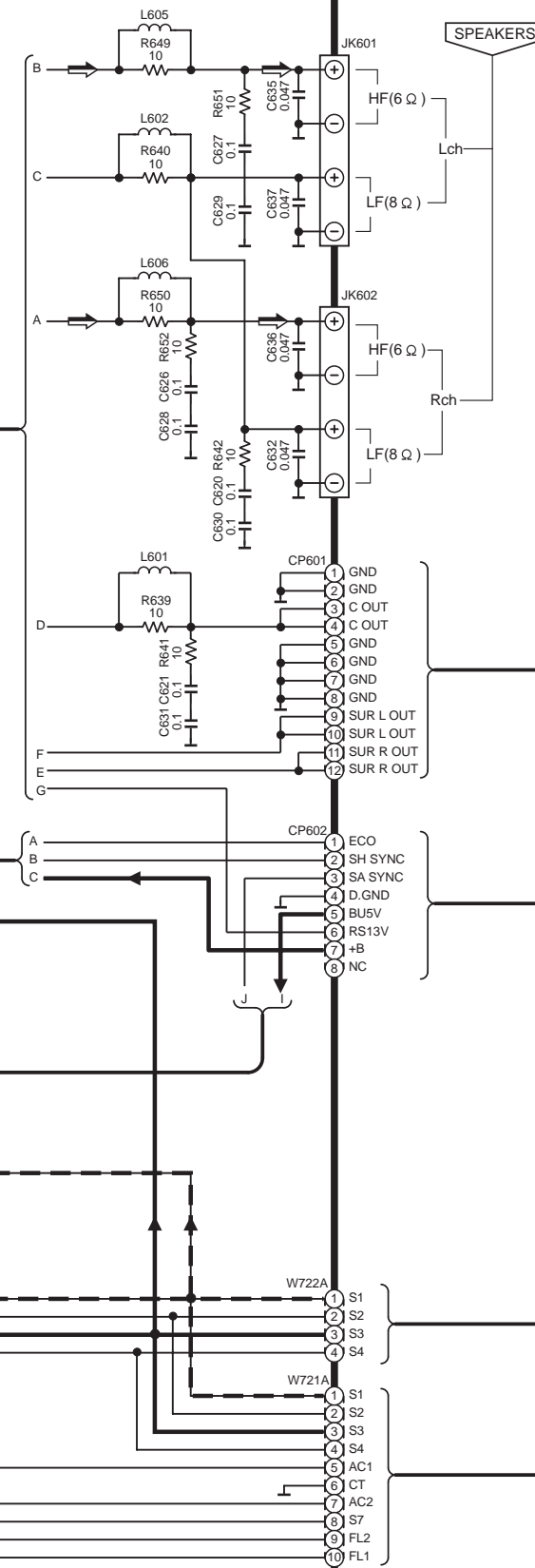

D AC IN CIRCUIT

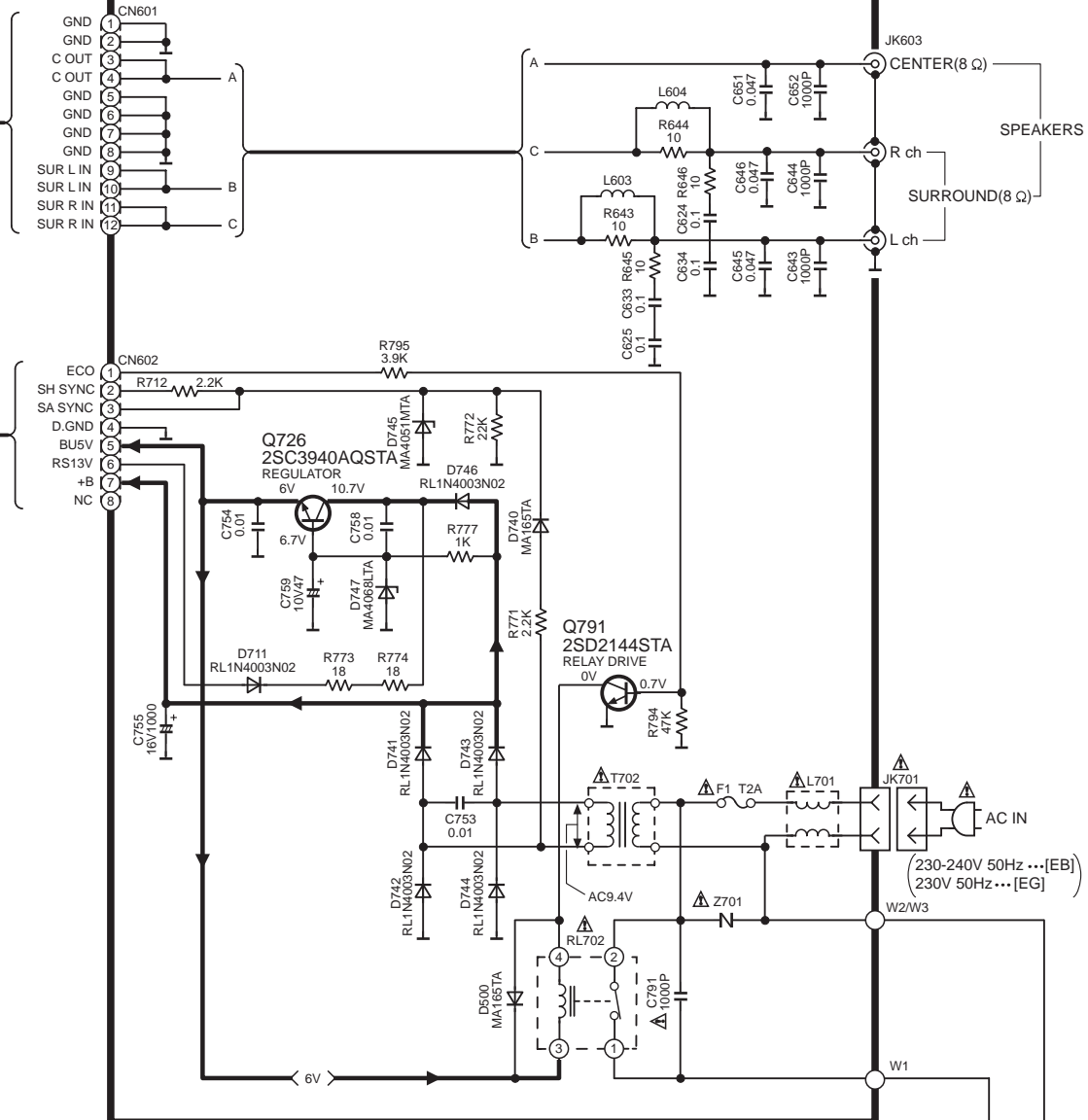

E POWER TRANSFORMER (A) CIRCUIT

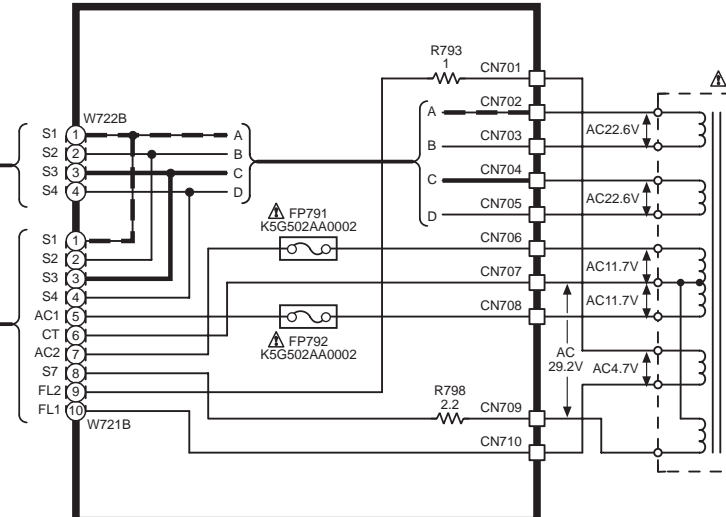

F POWER TRANSFORMER (B) CIRCUIT

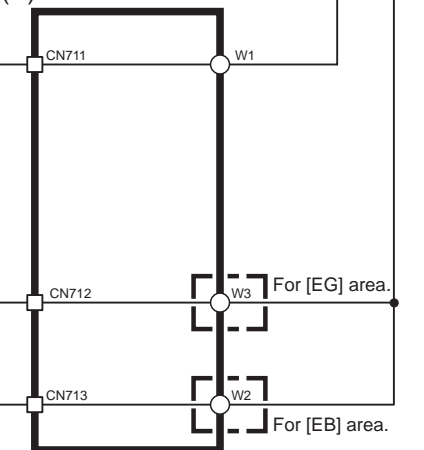

SCHEMATIC DIAGRAM-5

Z101 TUNER UNIT(RAN0005EM-2)

➔ : POSITIVE VOLTAGE LINE
⇨ : FM SIGNAL LINE
⇨ : AM SIGNAL LINE
⇨ : FM OSC SIGNAL LINE
⇨ : AM OSC SIGNAL LINE

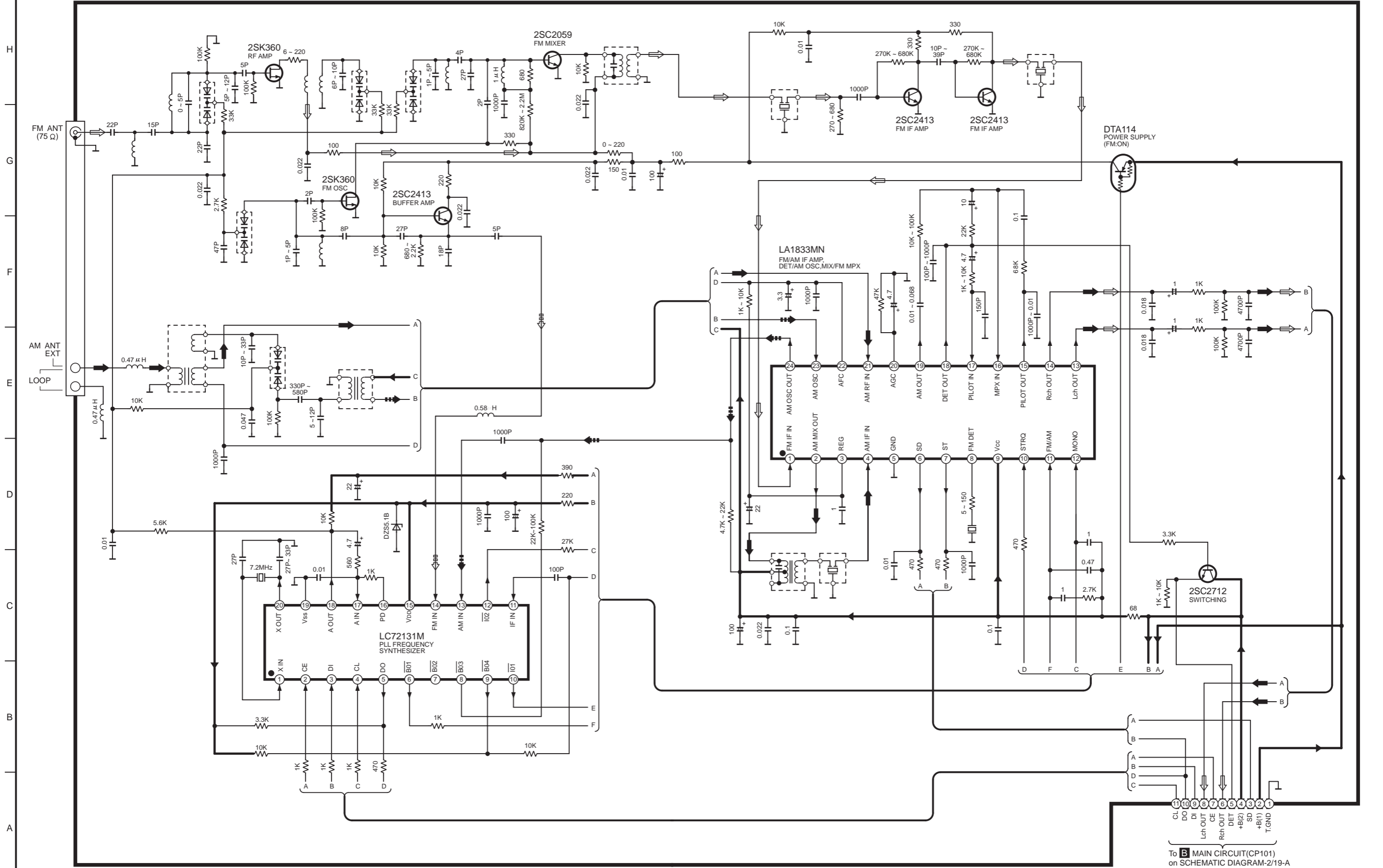

To **B** MAIN CIRCUIT(CP101)
on SCHEMATIC DIAGRAM-2/19-A

SCHEMATIC DIAGRAM-1

A OPERATION CIRCUIT

NOTE:

The number which noted at the connectors on the schematic diagram as "SCHEMATIC DIAGRAM-1" or "SCHEMATIC DIAGRAM-2" indicates the schematic diagram serial number located on the left corner in the schematic diagram.

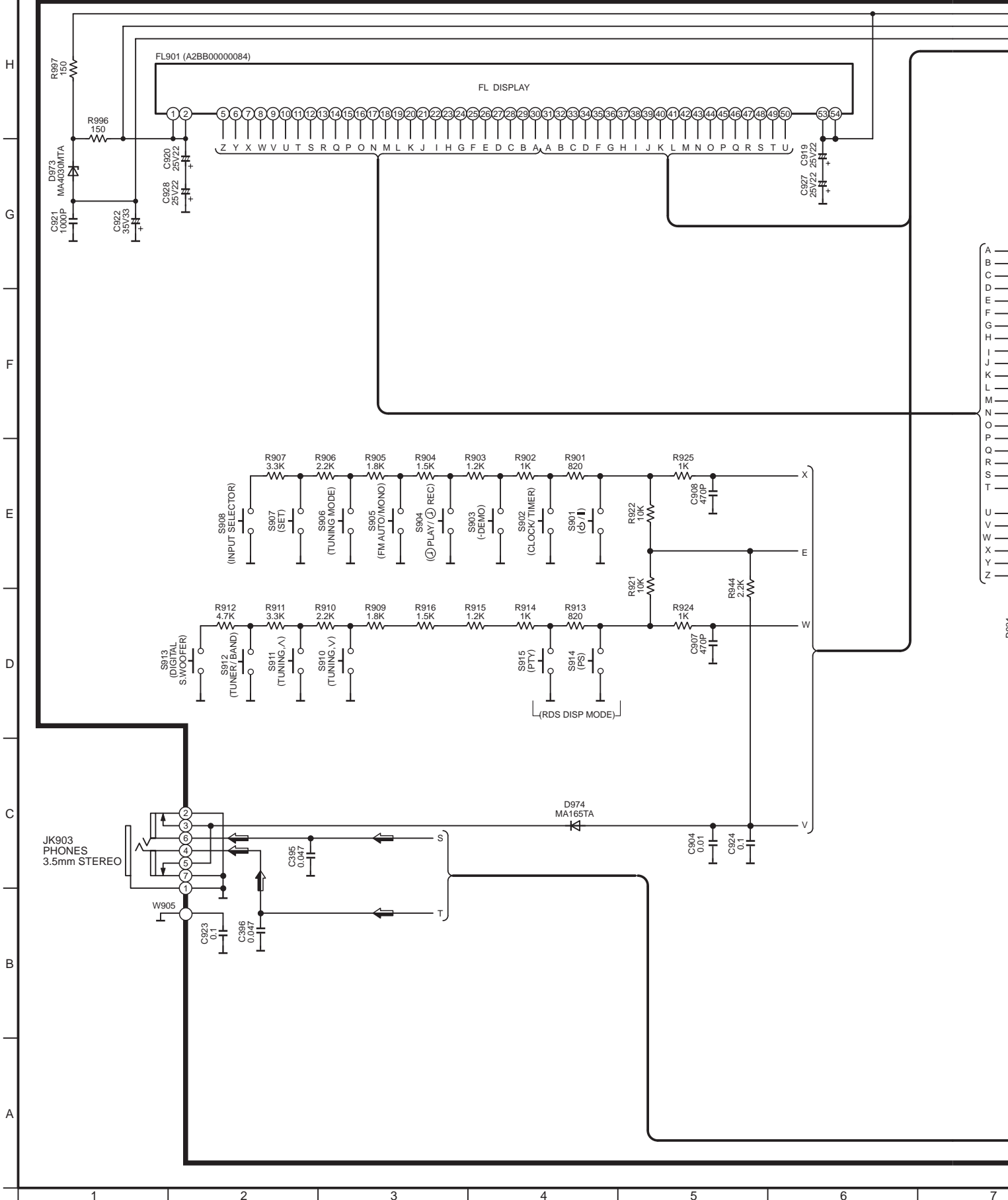

➔ : POSITIVE VOLTAGE LINE ➔- : NEGATIVE VOLTAGE LINE ➡ : AUDIO SIGNAL LINE

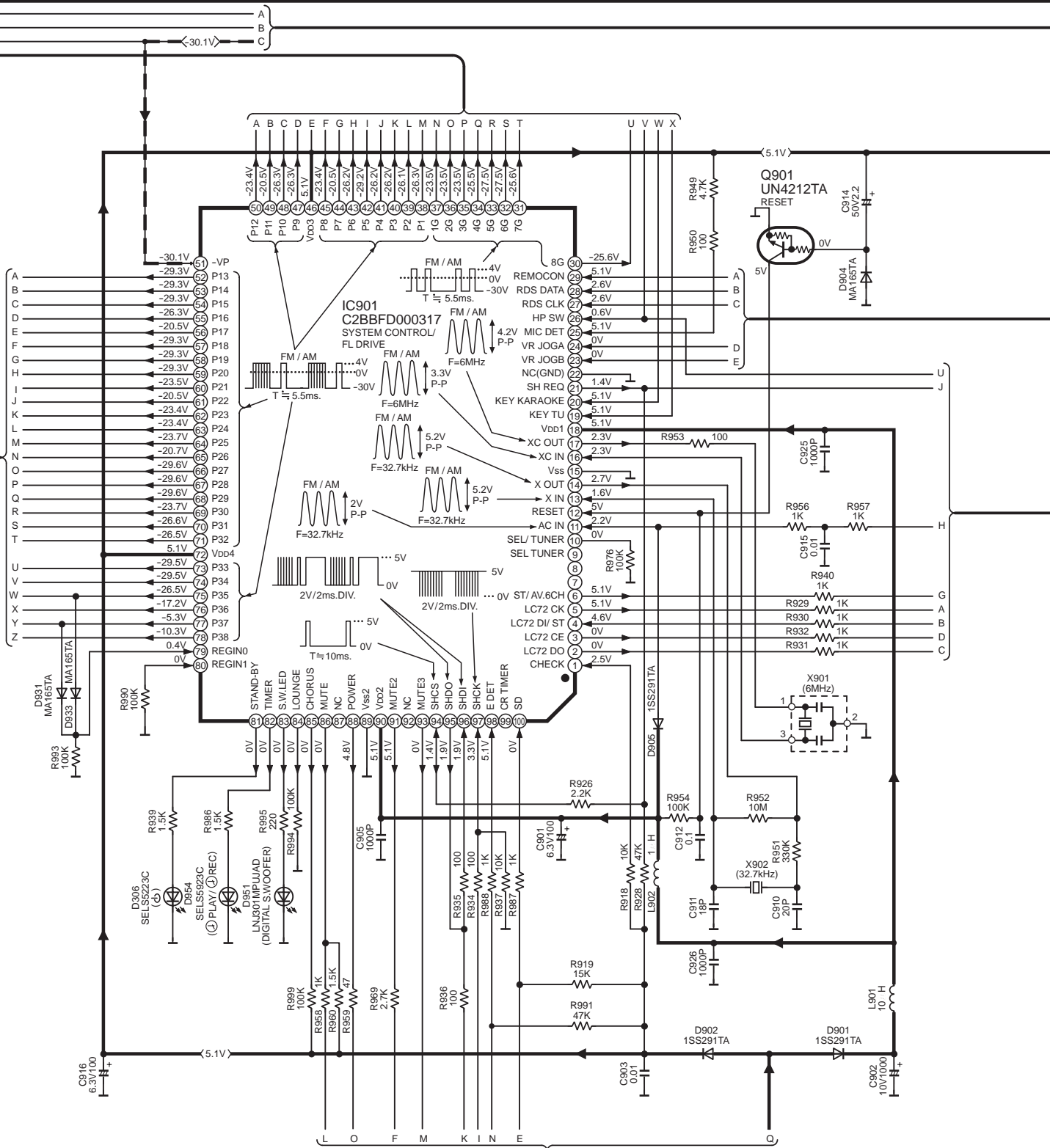

SCHEMATIC DIAGRAM-2
A OPERATION CIRCUIT

- - - : NEGATIVE VOLTAGE LINE - - - : FM SIGNAL LINE
 — — — : POSITIVE VOLTAGE LINE — — — : AM SIGNAL LINE — — — : AUDIO SIGNAL LINE

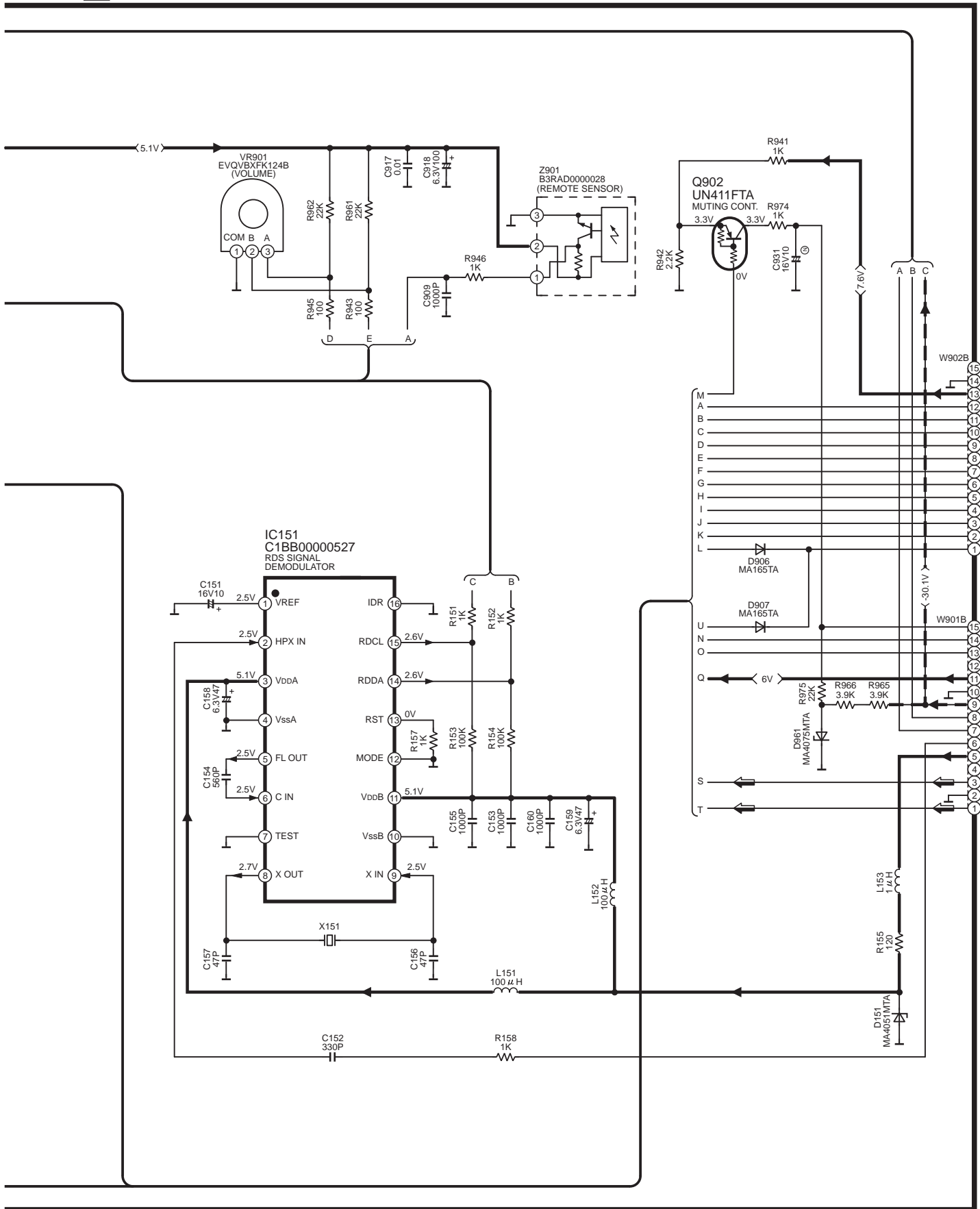

To SOUND PROCESSOR (SH-DV280)

TUNER Lch
 TUNER Rch
 A.GN
 Lch L
 Rch R
 +B(10)
 SUR
 SUR
 S.
 M
 -B(-10)
 V.GN
 D.GN
 CS/RE
 CI
 DA
 CT GN
 SH F
 SH F
 SYN

To TUNER UNIT on SCHEMATIC DIAGRAM-5/11,12-A

T.GN
 +B
 S
 +B
 DI
 Rch
 C
 Lch
 D
 C

B MAIN CIRCUIT

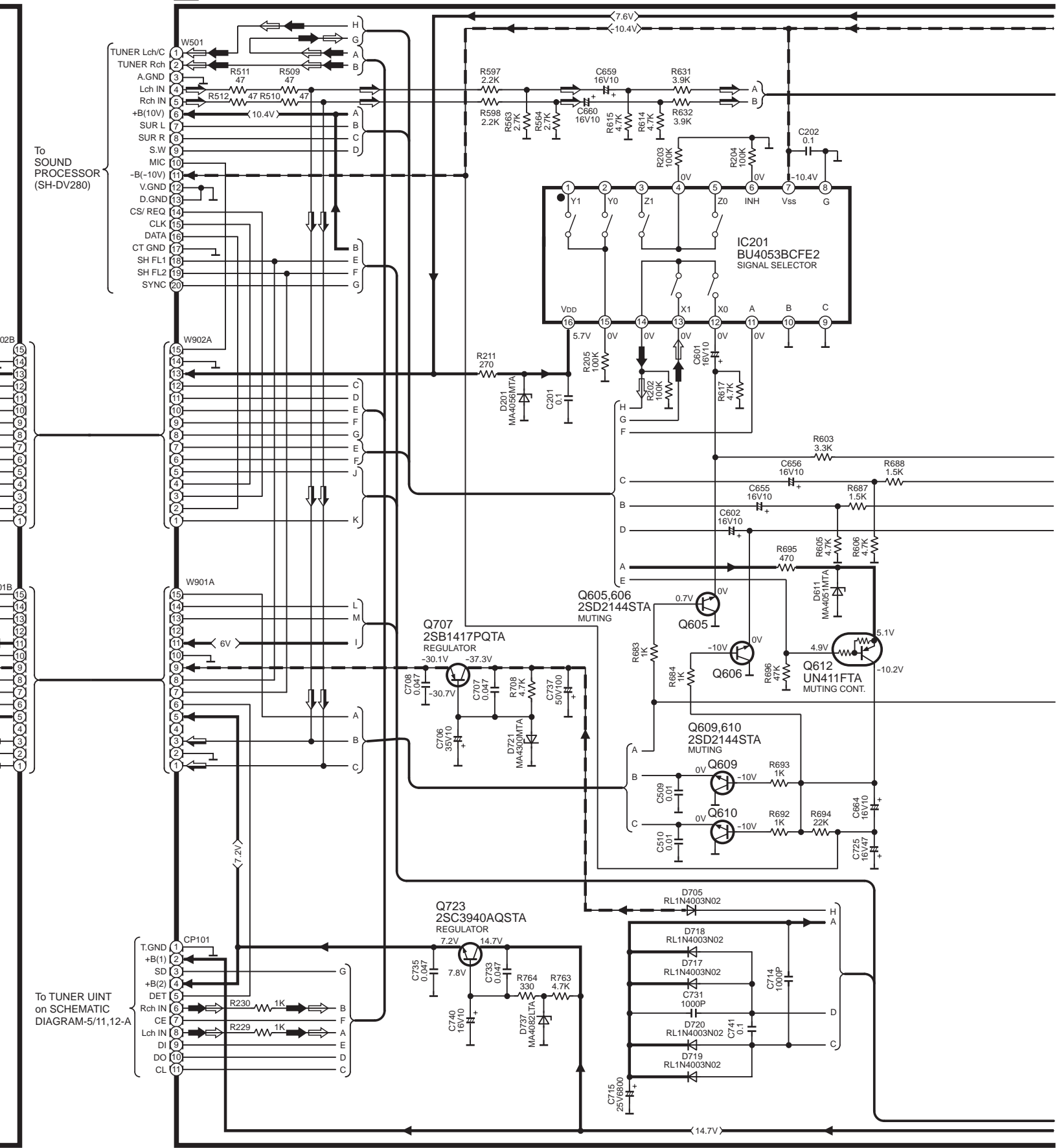

SCHEMATIC DIAGRAM-3

B MAIN CIRCUIT

— : POSITIVE VOLTAGE LINE
 - - : NEGATIVE VOLTAGE LINE ⇨ : AUDIO SIGNAL LINE

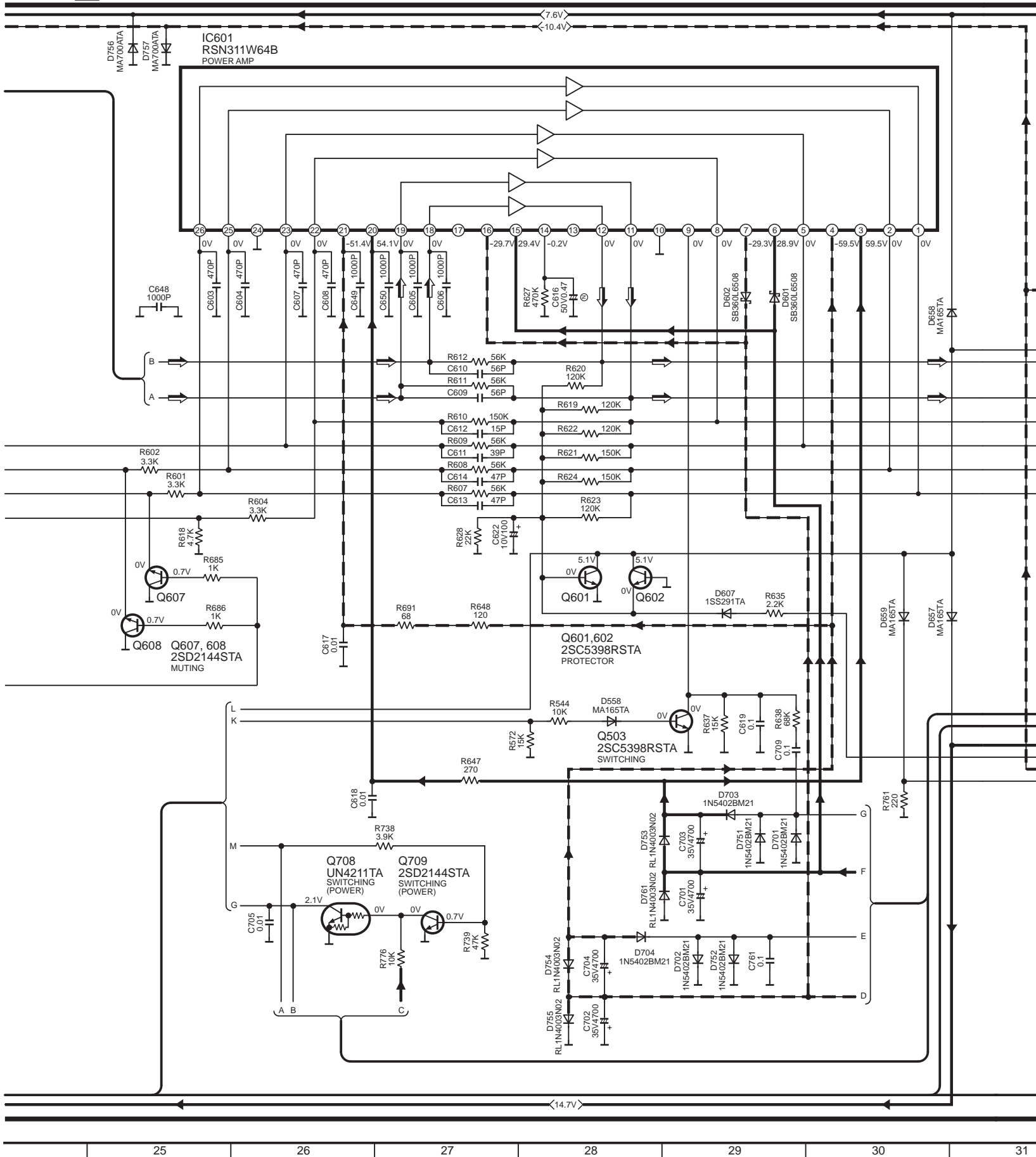

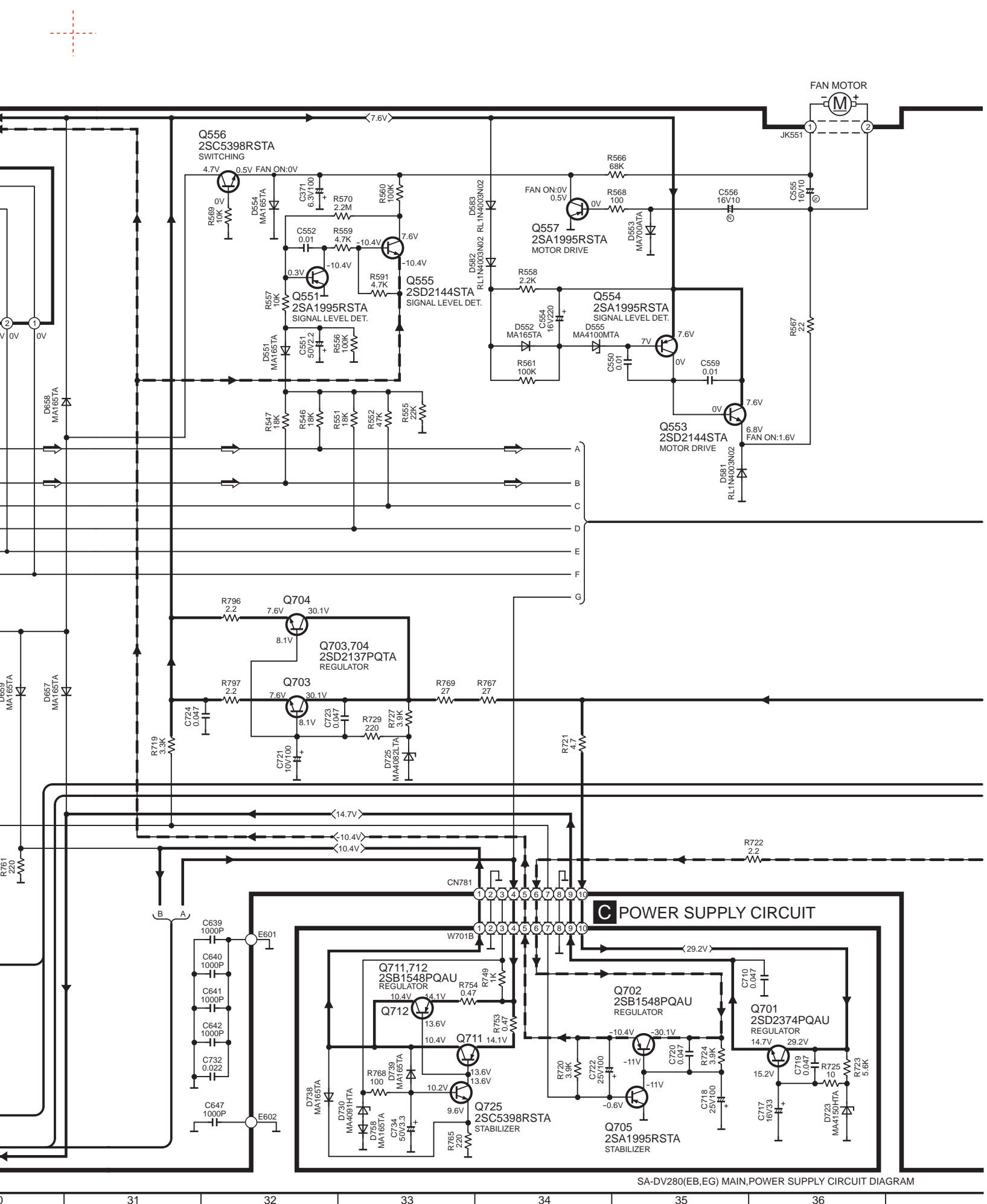

SA-DV280(EB,EG) MAIN, POWER SUPPLY CIRCUIT DIAGRAM

31

32

33

34

35

36

SCHEMATIC DIAGRAM-4

B MAIN CIRCUIT

: POSITIVE VOLTAGE LINE
 : NEGATIVE VOLTAGE LINE : AUDIO SIGNAL LINE

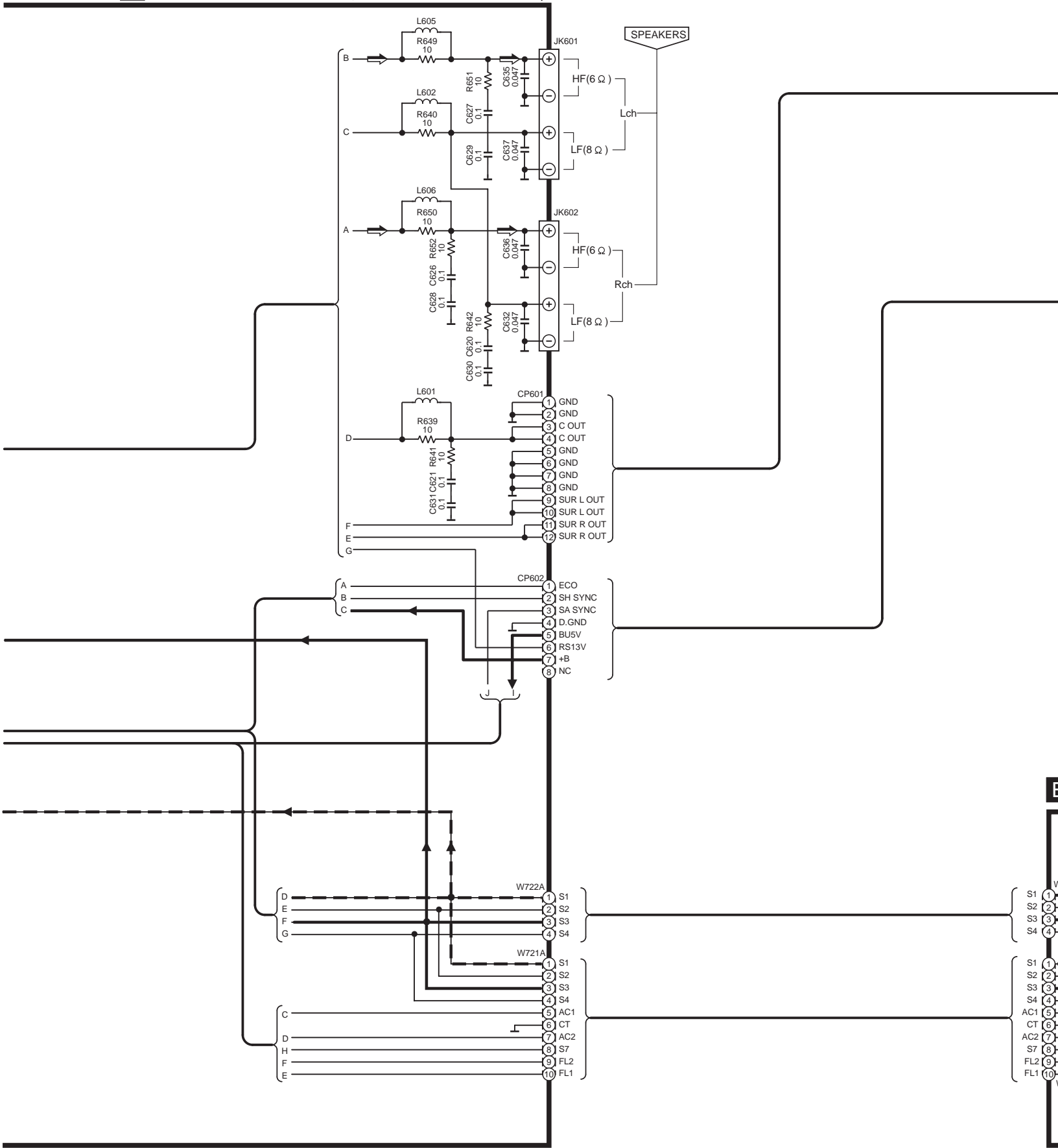

D AC IN CIRCUIT

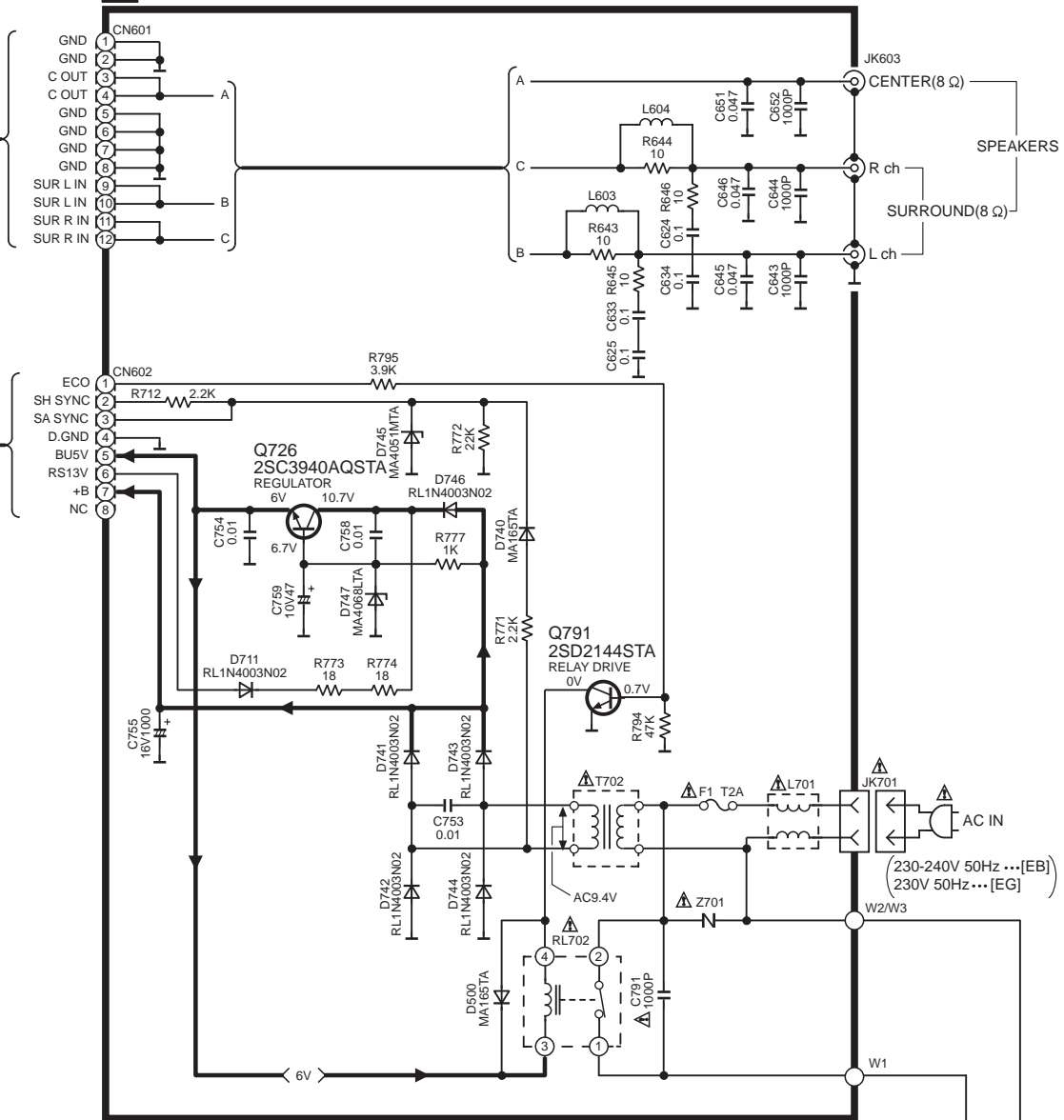

E POWER TRANSFORMER (A) CIRCUIT

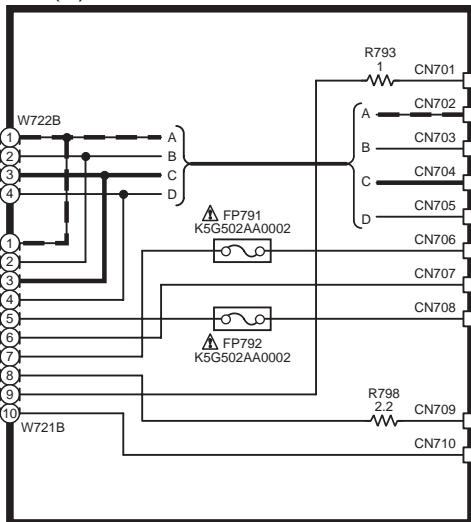

F POWER TRANSFORMER (B) CIRCUIT

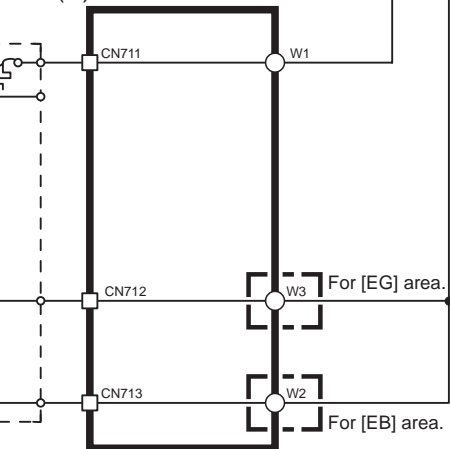

SA-DV280(EB,EG) MAIN, AC IN, POWER TRANSFORMER(A),(B) CIRCUIT DIAGRAM

H
G
F
E
D
C
B
A

SIGNAL LINE
C SIGNAL LINE

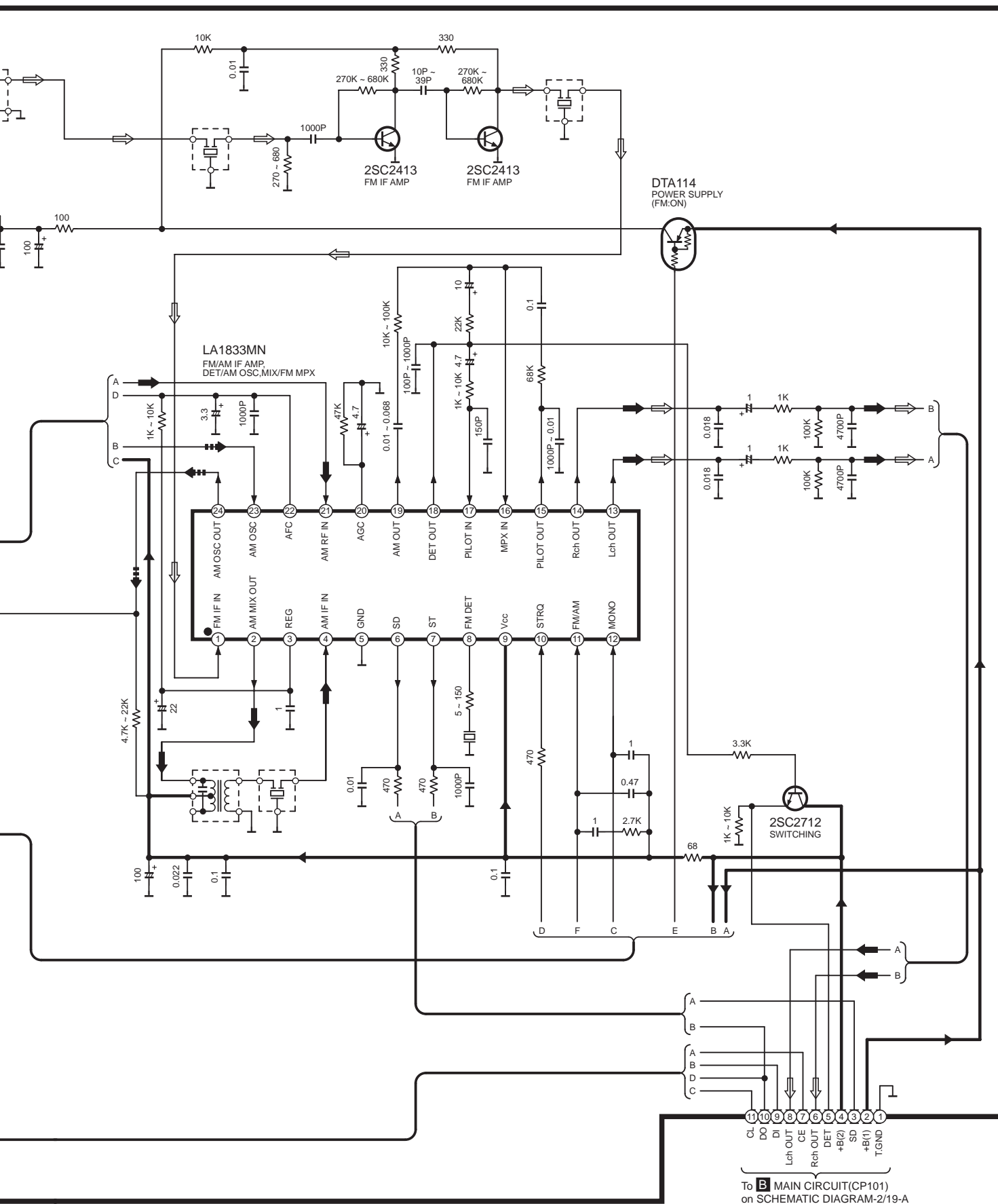

To **B** MAIN CIRCUIT(CP101)
on SCHEMATIC DIAGRAM-2/19-A

SA-DV280(EB,EG) TUNER UNIT CIRCUIT DIAGRAM

7 8 9 10 11 12

11 10 9 8 7 6 5 4 3 2 1
 CL DO DI CE DET +B(2) +B(1) TGND

BU4053BCFE2
C1BB00000527

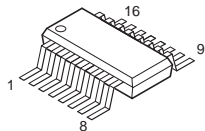

C2BBFD000317

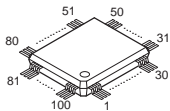

RSN311W64B

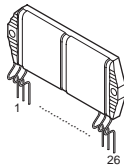

UN411FTA
UN4211TA
UN4212TA

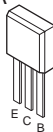

2SB1417PQTA
2SD2137PQTA

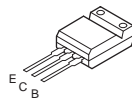

2SD2144STA

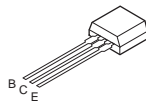

2SA1995RSTA
2SC5398RSTA

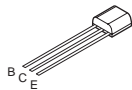

2SC3940AQSTA

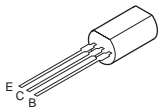

2SB1548PQAU
2SD2374PQAU

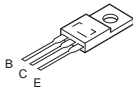

1SS291TA
MA700ATA

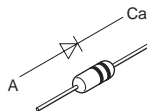

MA4100MTA
MA4150HTA
MA4300MTA

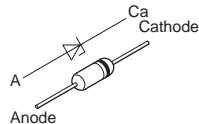

MA165TA

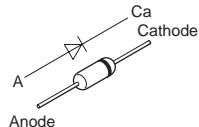

SB360L6508

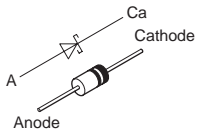

1N5402BM21
RL1N4003N02

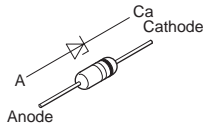
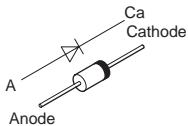

MA4030MTA
MA4051MTA
MA4056MTA
MA4068LTA
MA4075MTA
MA4082LTA
MA4091HTA

LNJ301MPUJAD

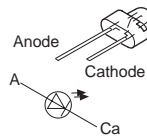

SELS5223C
SELS5923C

