

AD0303010C8

Service Manual

Cassette Deck



RS-DV290EG
Colour
(S).....Silver Type

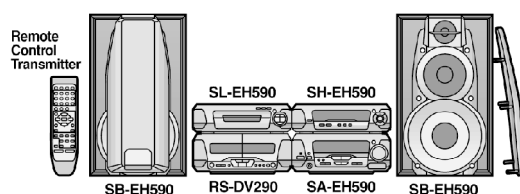

SPECIFICATIONS

Because of unique interconnecting cables, when a component requires service, send or bring in the entire system.

System	SC-EH590
Sound Processor	SH-EH590
Tuner/Amplifier	SA-EH590
CD Player	SL-EH590
Cassette Deck	RS-DV290
Front Speakers*	SB-EH590

* : Made in Singapore.

Specifications

Deck system:	Stereo cassette deck
Track system:	4 track, 2 channel
Recording system:	AC bias
Bias frequency:	100 kHz
Erasing system:	AC erase
Heads:	
Deck 1 (Playback head);	Permalloy head
Deck 2 (Recording/Playback head); (Erasing head);	Permalloy head Double gap ferrite head
Motors:	
Deck 1, 2 Capstan drive;	DC servo motor
Tape speed:	4.8 cm/s
Wow and flutter:	0.16 % (WRMS)
Fast forward and rewind times:	Approx. 110 seconds with C-60 cassette tape
Frequency response (Dolby NR off):	
TYPE I (NORMAL);	20 Hz – 16 kHz (DIN)
TYPE II (HIGH);	20 Hz – 16 kHz (DIN)
TYPE IV (METAL);	20 Hz – 16 kHz (DIN)

S/N (Signal level = max recording level, TYPE II type tape):
NR off; 56 dB (A weighted)
Dolby B NR on; 66 dB (A weighted)

Input sensitivity and impedance:
REC (IN); 150 mV/ 23 k Ω
Output voltage and impedance:
PLAY (OUT); 280 mV/ 360 Ω

General
Dimensions (W×H×D): 294×118.5×281 mm
Mass: 2.1 kg

Notes: Specifications are subject to change without notice.
 Mass and dimensions are approximate.

Manufactured under license from Dolby Laboratories.
 "Dolby" and the double-D symbol are trademarks of Dolby Laboratories.

⚠ WARNING

This service information is designed for experienced repair technicians only and is not designed for use by the general public. It does not contain warnings or cautions to advise non-technical individuals of potential dangers in attempting to service a product. Products powered by electricity should be serviced or repaired only by experienced professional technicians. Any attempt to service or repair the product or products dealt with in this service information by anyone else could result in serious injury or death.

Technics

1. Note

Refer to the service manual for Model No. SA-EH590EG, SA-EH590EP (Order No. AD0302008C8) for information on Accessories and Packaging.

2. Location of Controls

3. Operation Checks and Component Replacement / Procedures

- This section describes procedures for checking the operation of the major printed circuit boards and replacing the main components.
- For reassembly after operation checks or replacement, reverse the respective procedures. Special reassembly procedures are described only when required.

3.1. Checking for the main P.C.B.

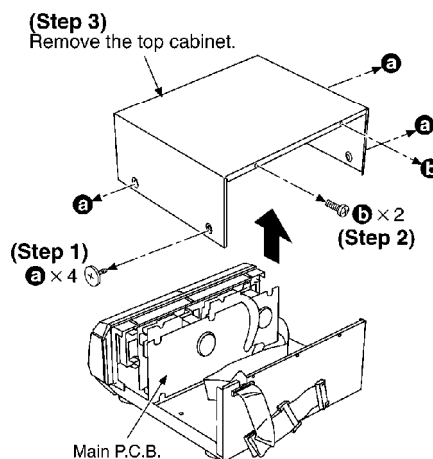

- Check the main P.C.B. as shown above.

3.2. Checking for the operation P.C.B.

- Follow the (Step 1) - (Step 3) of item 3.1.

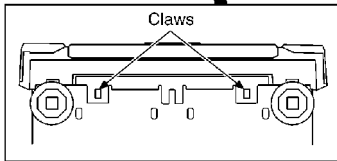
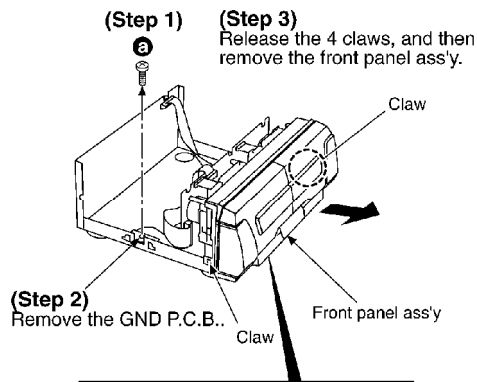

(Bottom side)

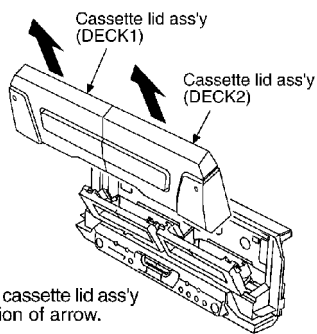
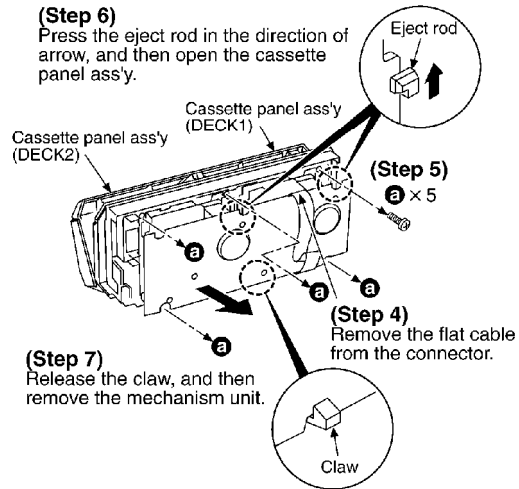

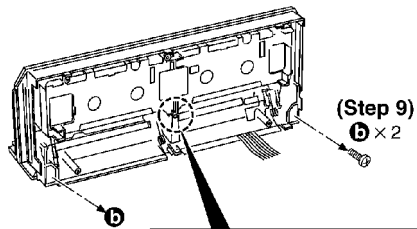

(Step 10)
Release the 2 claws,
and then remove the
deck mecha frame.

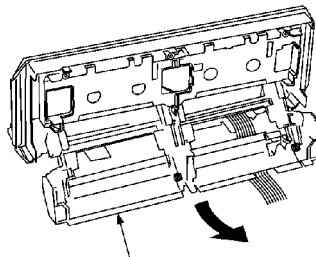
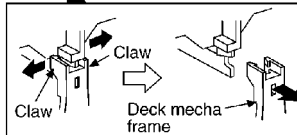

(Step 11)
Remove the deck mecha frame
in the direction of arrow.

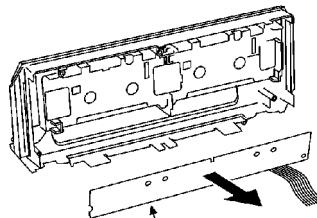

(Step 12)
Remove the operation P.C.B..

- Check the operation P.C.B. as shown below.

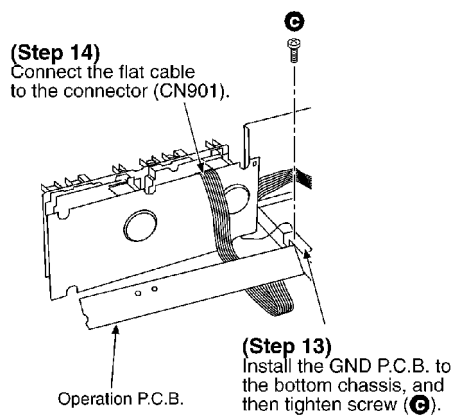

3.3. Replacement for the motor ass'y, capstan belt and winding belt

- Follow the (Step 1) - (Step 3) of item 3.1.

- Follow the (Step 1) - (Step 7) of item 3.2.

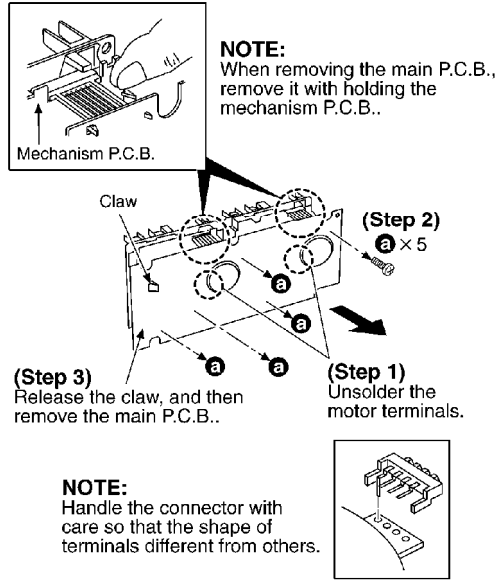

※ The illustration below shows DECK2 mechanism.
For DECK1 mechanism, perform the same procedure as DECK2.

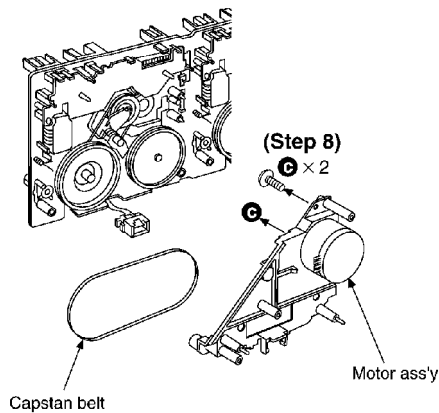
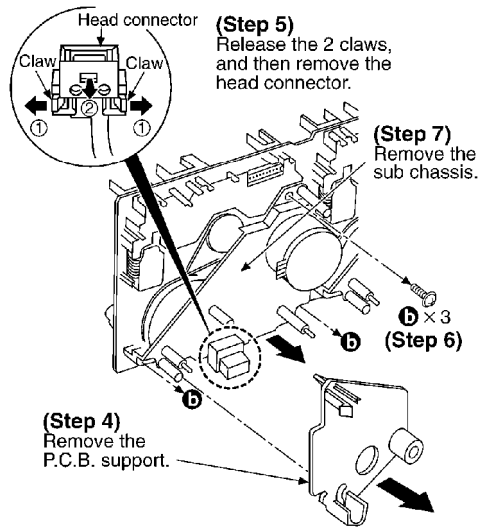

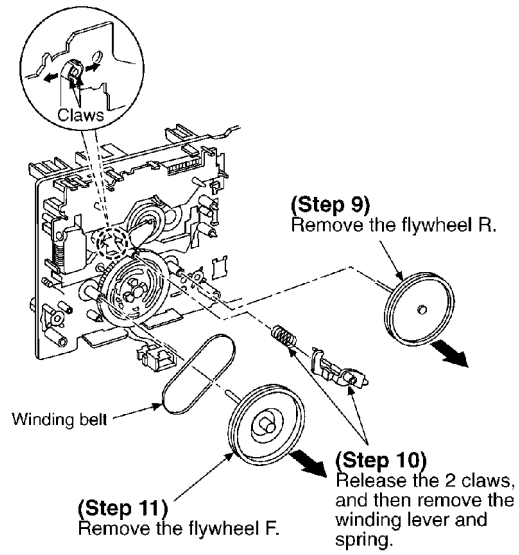

Installation of the belt

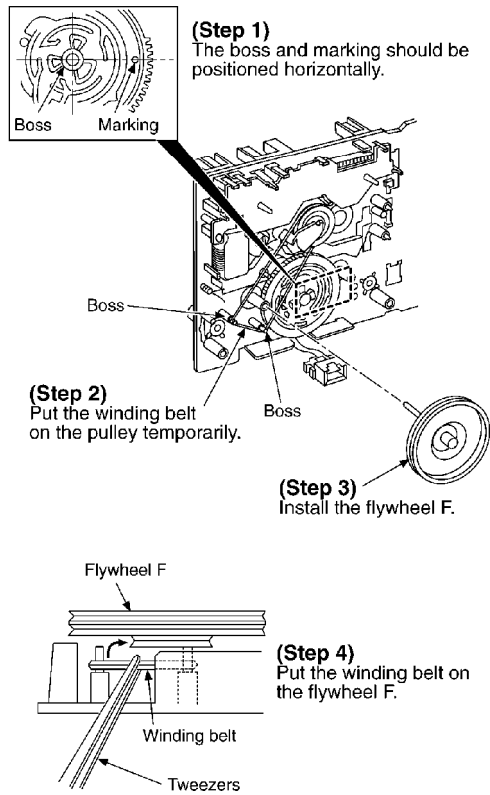

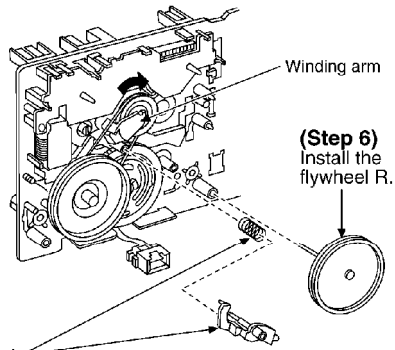

(Step 6)
Install the flywheel R.

(Step 5)
Install the winding lever and spring while pressing the winding arm in the direction of arrow.
(The winding lever must be inserted completely and latched with claws.)

NOTE:
The winding lever should be positioned as shown right.

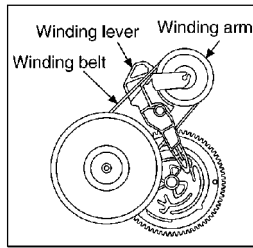

(Step 7)
Put the capstan belt temporarily as shown below.

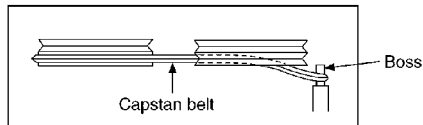
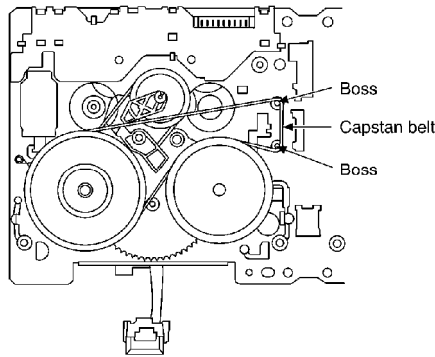

(Side view)

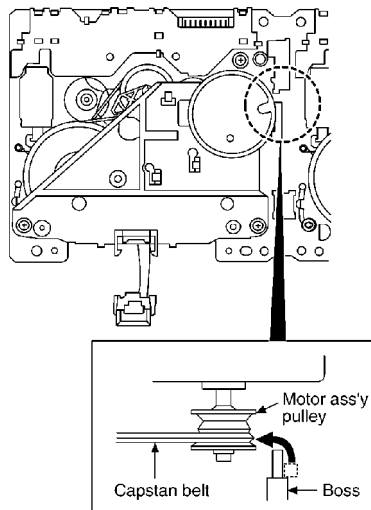
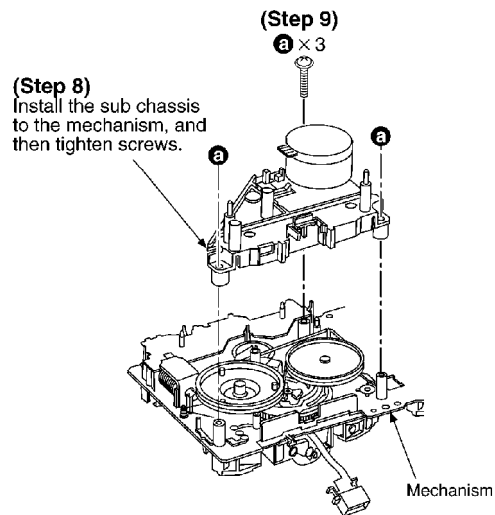

(Step 10)
Put the capstan belt on the motor ass'y pulley.

3.4. Replacement for the components parts on the mechanism P.C.B.

- Follow the (Step 1) - (Step 3) of item 3.1.
- Follow the (Step 1) - (Step 7) of item 3.2.
- Follow the (Step 1) - (Step 4) of item 3.3.

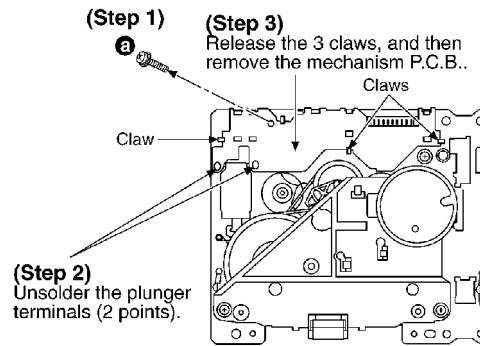

3.5. Replacement for the pinch roller ass'y and head block

- Follow the (Step 1) - (Step 3) of item 3.1.
- Follow the (Step 1) - (Step 7) of item 3.2.
- Follow the (Step 1) - (Step 5) of item 3.3.

※ The mechanism as shown below is for DECK2.
For the one of DECK1, perform the same procedures.

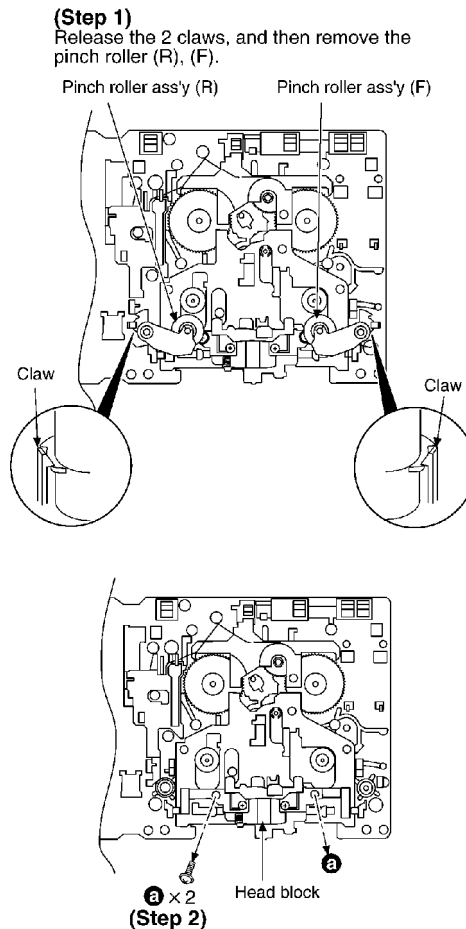

3.6. Replacement for the cassette lid ass'y

- Follow the (Step 1) - (Step 3) of item 3.1.

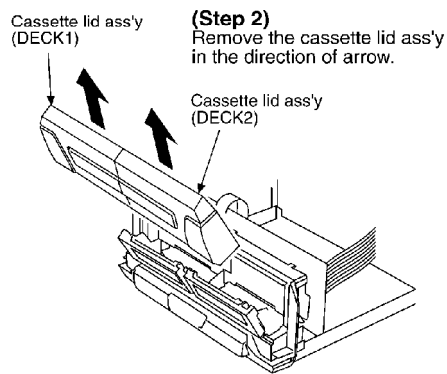
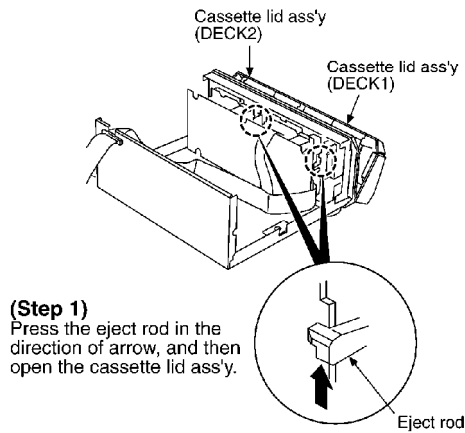

3.7. Replacement for the cassette holder

- Follow the (Step 1) - (Step 3) of item 3.1.
- Follow the (Step 1) - (Step 11) of item 3.2.

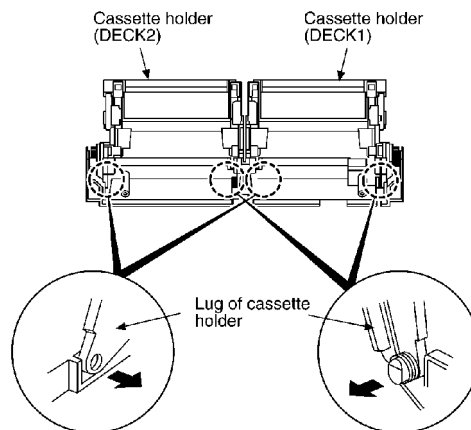

- Release the lug of cassette holder in the direction of arrow.

■ Open spring installation

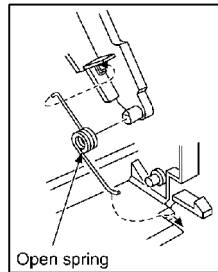

4. To Supply Power Source

This unit is designed to operate on power supplied from system connected. / When a component requires service, use the system connections to supply power source. / For system connections, refer to [Fig.4-1](#).

Fig. 4-1.

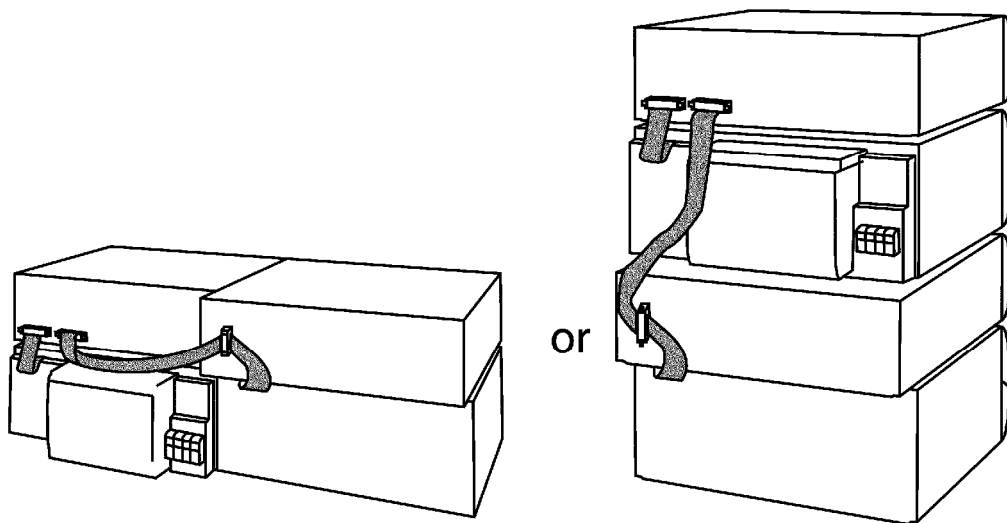

5. Service Mode Function of Cassette Mechanism

This unit is equipped with a service mode function of cassette mechanism, so that if the unit operates incorrectly, the fault displayed using an error code on the FL display of the Tuner/Amplifier (SA-EH590). The system control IC and FLdisplay are part of the Tuner/Amplifier so make sure the system has been connected properly before using this function. Use this function during maintenance to check faults of items below.

5.1. Cassette tape to be prepared

Metal tape:

Recorded music tape with only one erasure prevention tab intact. / (use middle portion of tape)

Normal tape: / CrO2 tape:

Recorded music tape with both erasure prevention tabs intact. / (use middle portion of tape)

5.2. Selecting service mode

1. Turn on the power to the unit.
2. Make sure that no tape is inserted in the cassette deck. (Service mode cannot be selected with a tape inserted in the cassette deck.)
3. Press the DOLBY NR button for about 2 seconds, and keep pressing it, also press the STOP button for about 2 seconds. Refer to [Fig. 5-1](#).

Fig. 5-1.

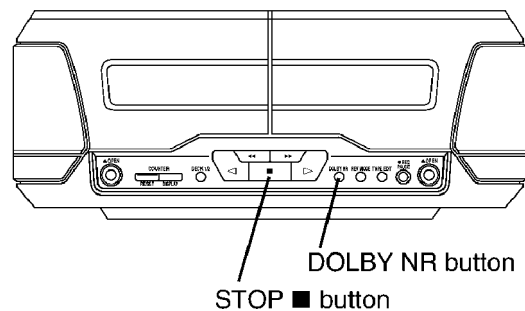

5.3. Deck 1 mechanism check

1. Press the Deck 1/deck 2 select button to change the flashing Deck 2 indicator to Deck 1. Refer to [Fig. 5-2](#). / (No change required if Deck 1 indicator already flashing.)
2. Press the Deck 1 cassette holder open button to open the Deck 1 cassette holder. Refer to [Fig. 5-2](#).
3. Insert a CrO₂ tape into the Deck 1 and close the cassette holder.
4. Press the Fast forward button. Refer to [Fig. 5-2](#). / (Tape fast forwards for about 2 seconds then stops.)
5. Press the PLAY button. Refer to [Fig. 5-2](#). / (After TPS operation and check, the tape stops.)
6. Open the Deck 1 cassette holder and replace the tape with a normal tape.
7. Close the Deck 1 cassette holder.
8. Press the Record pause button. Refer to [Fig. 5-2](#). / (No record operation.)
9. Press the STOP button. Refer to [Fig. 5-2](#). A mechanism error code is displayed. Refer to Table 5-1. Each time the STOP button is

pressed, the fault items are displayed in sequence.

Fig. 5-2.

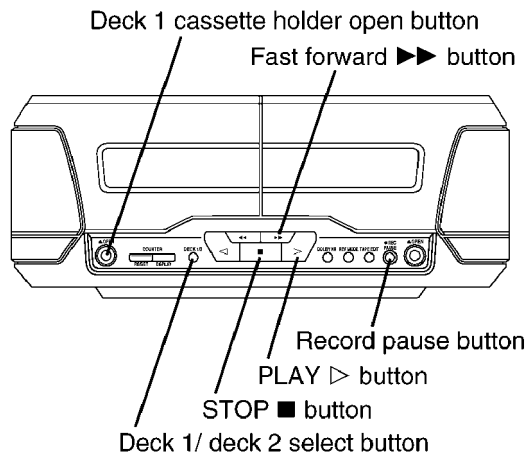

Table 5-1.

FL display	Symptom	Cause
H01	Cassette deck does not operate correctly.	Faulty cassette deck mechanism mode switch (Deck 1: S951, Deck 2: S971), pl and capstan motor. / (Check and repla
H02	Unit does not record or the unit goes into recording mode even when the erasure prevention tabs have been removed from the cassette.	Faulty erasure prevention tabs detect (S974, S975) or short-circuit. (Check and replace)
H03	Tape does not play even when the tape deck play button is pressed. The motor operates when the tape deck play button is pressed even if cassette is loaded in the deck.	Faulty tape detect switch (Deck 1: S95, S972) or short-circuit. (Check and repl
H06	Cassette deck does not detect CrO2 tape.	Faulty CrO2 tape detect switch (Deck 1 Deck 2: S973). / (Check and replace)
H07	Cassette deck does not detect Metal tape.	Faulty Metal tape detect switch (S976). and replace)
F01	When the tape play button is pressed, tape advances only slightly and then stops.	Reel pulse error (Faulty Hall IC). (Check replace)
F02	TPS (tape program search) does not work.	Faulty TPS signal detection or faulty pl control. / (Check and replace mechani control IC)

5.4. Deck 2 mechanism check

1. Press the Deck 1/deck 2 select button to change the flashing Deck 1 indicator to Deck 2. Refer to **Fig. 5-3**.
2. Press the Deck 2 cassette holder open button to open the Deck 2

- cassette holder. Refer to [Fig. 5-3](#).
3. Insert a metal tape into the Deck 2 with an intact erasure prevention tab on the right side.
 4. Close the Deck 2 cassette holder.
 5. Press the Fast forward button. Refer to [Fig. 5-3](#). / (Tape fast forwards for about 2 seconds then stops.)
 6. Open the Deck 2 cassette holder and turn over the metal tape. (intact erasure prevention tab on the left side.)
 7. Close the Deck 2 cassette holder.
 8. Press the Rewind button. Refer to [Fig. 5-3](#). / (Tape rewinds for about 2 seconds then stops.)
 9. Open the Deck 2 cassette holder and replace the metal tape with a CrO2 tape.
 10. Close the Deck 2 cassette holder.
 11. Press the PLAY button. Refer to [Fig. 5-3](#). / (After TPS operation and check, the tape stops.)
 12. Open the Deck 2 cassette holder and replace the CrO2 tape with a normal tape.
 13. Close the Deck 2 cassette holder.
 14. Press the Record pause button. Refer to [Fig. 5-3](#). / (No record operation.)
 15. Press the STOP button. Refer to [Fig. 5-3](#). A mechanism error code is displayed. Refer to Table 5-1. Each time the STOP button is pressed, the fault items are displayed in sequence.

Fig. 5-3.

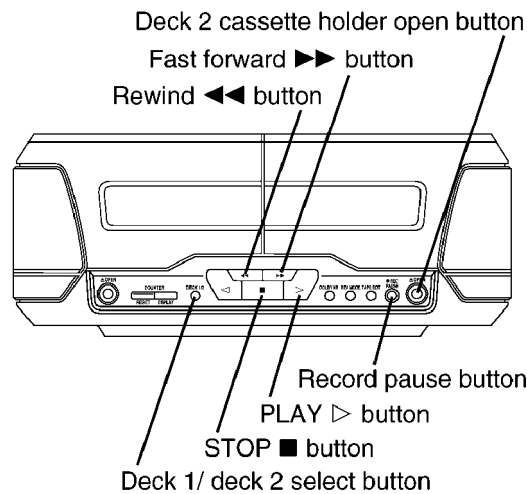

5.5. Exiting service mode

1. Press the **STOP** button for more than 5 seconds. (Diagnostic contents stored in memory for both Deck 1 and 2 are erased.)
2. Remove the cassette tape from the cassette holder.
3. Turn off the unit.

6. Schematic Diagram Notes

- This schematic diagram may be modified at any time with the development of new technology.

Notes:

S900:

Stop switch (■)

S901:

Deck 2 cassette holder open switch (▲ OPEN)

S903:

Tape edit switch (TAPE EDIT)





S904:

Record pause switch / (● REC PAUSE)

S905:

Dolby noise reduction switch / (DOLBY NR)

S906:

- Fast forward, TPS switch ()**
- S907:**
- Forward side playback switch ()**
- S909:**
- Reverse side playback switch ()**
- S910:**
- Rewind, TPS switch ()**
- S911:**
- Reverse mode switch / (REV MODE)**
- S912:**
- Deck 1/deck 2 select switch / (DECK 1/2)**
- S913:**
- Counter display switch / (COUNTER DISPLAY)**
- S914:**
- Counter reset switch / (COUNTER RESET)**
- S915:**
- Deck 1 cassette holder open switch ( OPEN)**
- S951:**
- Deck 1 mode detect switch**
- S952:**
- Deck 1 half detect switch**
- S953:**
- Deck 1 CrO2 tape detect switch**
- S971:**
- Deck 2 mode detect switch**
- S972:**
- Deck 2 half detect switch**
- S973:**
- Deck 2 CrO2 tape detect switch**

S974:

Deck 2 reverse side record prevention tab detect switch

S975:

Deck 2 forward side record prevention tab detect switch

S976:

Deck 2 METAL tape detect switch

VR101:

Deck 1 playback gain adjustment VR / (R ch)

VR102:

Deck 2 playback gain adjustment VR / (L ch)

VR103:

Deck 2 playback gain adjustment VR / (R ch)

VR104:

Deck 1 playback gain adjustment VR / (L ch)

VR801:

Deck 1 tape speed adjustment VR (normal)

VR803:

Deck 2 tape speed adjustment VR (normal)

- Indicated voltage values are the standard values for the unit measured by the DC electronic circuit tester (high-impedance) with the chassis taken as standard. Therefore, there may exist some errors in the voltage values, depending on the internal impedance of the DC circuit tester.

No mark

: Playback

()

: Recording

- Important safety notice:

Components identified by  mark have special characteristics important for safety.

Furthermore, special parts which have purposes of fire-retardant (resistors), high-quality sound (capacitors), low-noise (resistors), etc. are used.

When replacing any of components, be sure to use only manufacturer's specified parts shown in the parts list.

- The supply part number is described alone in the replacement parts list.

- Caution!

IC and LSI are sensitive to static electricity.

Secondary trouble can be prevented by taking care during repair.

Cover the parts boxes made of plastics with aluminum foil.

Ground the soldering iron.

Put a conductive mat on the work table.

Do not touch the legs of IC or LSI with the fingers directly.

- Voltage and signal line



: Positive voltage line



: Playback signal line



: Recording signal line

7. Schematic Diagram

8. Printed Circuit Board Diagram

9. Type Illustration of ICs, Transistors and Diodes

10. Wiring Connection Diagram

11. Block Diagram

12. Terminal Function of ICs

12.1. IC701 (M38503M2406F): / System Control

Pin No.	Terminal Name	I/O	Function
1	Vcc	I	Power supply terminal
2	VREF	I	Reference voltage input
3	AVss	-	GND terminal
4	LMT	O	Muting control signal output
5	PL1	O	Deck 1 solenoid control signal output
6	M1	O	Deck 1 motor drive control signal output
7	HALT	I	Power failure detect signal input
8	REQ	I	Serial communication request signal input
9	CS	I	Serial communication complete signal input
10	CLK	O	Serial communication clock signal output
11	DATA OUT	O	Serial communication data signal output
12	DATA IN	I	Serial communication data signal input
13	METAL 2	I	Deck 2 tape detect switch signal (METAL) input
14	CRO2 2	I	Deck 2 tape detect switch signal (CrO2) input
15	Vss	-	GND terminal
16	FWD LED	O	LED drive control signal (FWD) output
17	REV LED	O	LED drive control signal (REV) output
18	RESET	I	Reset signal input
19	XIN	I	Oscillator connected terminal (F=8 MHz)
20	XOUT	O	
21	Vss	-	GND terminal
22	CRO2 1	I	Deck 1 tape detect switch signal (CrO2) input
23	MODE	I	Deck 1 mechanism switch signal (MODE) input
24	HALF1	I	Deck 1 mechanism switch signal (Half) input
25	TPS	I	TPS signal input
26	A DATA	O	Serial data signal output for IC 101
27	A CLK	O	Serial clock signal output for IC 101
28	A LATCH	O	Serial latch signal output for IC 101

Pin No.	Terminal Name	I/O	Function
29	PL2	O	Deck 2 solenoid control signal output
30	M2	O	Deck 2 motor drive control signal output
31	ENC/DEC	O	Dolby NR record/playback mode select signal output
32	DOLBY ON/OFF	O	Dolby NR ON/OFF control signal output
33	E CS	-	EEPROM chip select signal output (Not used, open)
34 36	NC	-	Not used, open
37	LED CNT	O	LED color control signal output
38	PHOTO2T	I	Deck 2 reel pulse detect signal input
39	AD SW	I	Deck 2 mechanism switch signal input (Half, Mode, F REC INH., R REC INH.)
40	PHOTO1T	I	Deck 1 reel pulse detect signal input
41	KEY2	I	Operation key signal input
42	KEY1	I	Operation key signal input

13. Measurements and Adjustments

Note:

This unit RS-DV290 is designed to operate on power supplied from system connected.

13.1. Measurement condition

- Dolby NR switch is OFF
- Make sure heads are clean
- Make sure capstan and pressure roller are clean
- Temperature is 20 ± 5 °C

13.2. Measurement instrument and special tool

- Electronic Voltmeter
- Frequency Counter

- AF Oscillator
- Test tape
- Head azimuth adjustment (8 kHz, -20 dB): QZZCFM
- Tape speed adjustment (3 kHz, -10 dB): QZZCWAT
- Playback gain adjustment (315 Hz, 0 dB): QZZCFM
- Recording/playback frequency response check:
 - QZZCFM / (315 Hz, -20 dB, 12.5 kHz~63 Hz, -20 dB)
 - QZZCRA4 (Normal blank tape)
 - QZZCRX2 (CrO2 blank tape)
 - QZZCRZ6 (Metal blank tape)

13.3. Head azimuth adjustment (Deck 1/2)

1. Connect the measuring instrument as shown in **Fig. 13-1**.
2. Replace azimuth screws for both forward and reverse directions after removing the screw-locking bond left on the head base. (Supply part No. of azimuth screw: RHD17015)
3. Playback the azimuth adjustment portion (8 kHz, -20 dB) of test tape (QZZCFM). Adjust the azimuth screw until the outputs of the L/ R ch are maximized. Refer to **Fig. 13-2**. Make sure that the difference in the peak level between the left and right channels does not exceed 0.5 dB.
4. Perform the same adjustment in reverse playback mode. Check of the level difference forward and reverse directions.
5. Playback the playback gain adjustment portion (315 Hz, 0 dB) of test tape (QZZCFM). Check if level difference between forward and reverse direction is within 1.5 dB.
6. After the adjustment, apply screw lock to the azimuth screw.

Fig. 13-1.

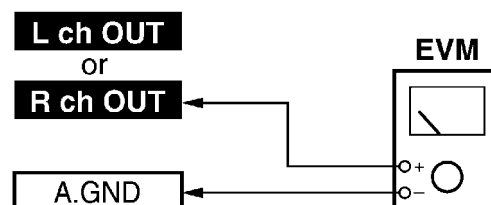
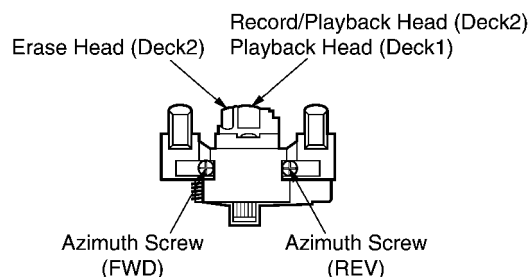

Fig. 13-2.



13.4. Tape speed adjustment / (Deck 1/2)

Note:

When connecting the unit to other system components for test, short the section between the test point TP604 and TP609 and turn on the entire system. (The unit is set to the TEST mode, and either Deck 1 or Deck 2 indicator will blink.)

Normal speed (Standard value: 3000 ± 45 Hz)

1. Connect the measuring instrument as shown in [Fig. 13-3](#).
2. Playback the middle portion of test tape. (QZZCWAT)
3. Adjust VR801 (Deck 1) and VR803 (Deck 2) for output value shown below. (For adjustment point, refer to [Fig. 13-11](#).)
 Adjustment target: 3000 ± 15 Hz (Normal speed)
 Standard value: 3000 ± 45 Hz (Normal speed)

Fig. 13-3.

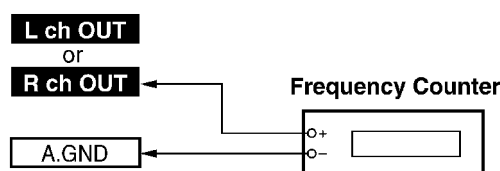

Note:

When the unit is finished for adjusting, disconnect the short section between TP604 and TP609 .

13.5. Playback gain adjustment (Deck 1/2)

1. Connect the measuring instrument as shown in [Fig. 13-4](#).
2. Find the start of the 315 Hz, 0 dB section of test tape (QZZCFM), insert the tape into Deck 1 and 2, and play it back (FWD).
3. Adjust Deck 2: VR102 (L ch) [VR103 (R ch)] and Deck 1: VR104 (L ch) [VR101 (R ch)] so that the output is within the standard value shown below. (For adjustment point, refer to [Fig. 13-11](#).)

[Standard value:265 mV ~ 300 mV]

Fig. 13-4.

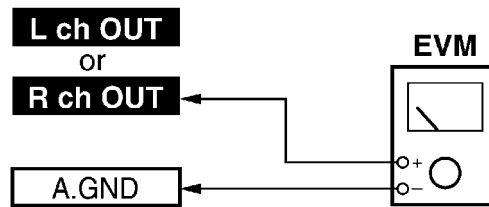

13.6. Erase current confirmation (Deck 2)

1. Connect the measuring instrument as shown in [Fig. 13-5](#).
2. Insert the blank tape into Deck 2, and press the Record pause button.
3. Check if the output at this time between the erase current confirmation point TP301 and TP302 (the output on both edged of R313) is within the standard value shown below. (For the erase current confirmation point, refer to [Fig. 13-11](#).)

	Standard Value	EVM reading
Normal tape :	85 ± 25 mA	(85 ± 25 mV)
CrO2 tape:	150 ± 25 mA	(150 ± 25 mV)
Metal tape:	185 ± 25 mA	(185 ± 25 mV)

Fig. 13-5.

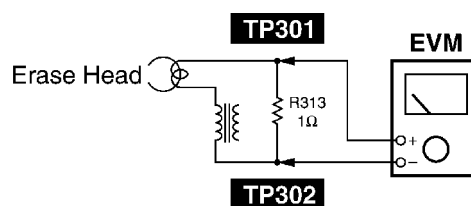

Note:

The test tape is not required when confirming the erase current.

13.7. Playback frequency response check (Deck 1/2)

1. Connect the measuring instrument as shown in [Fig. 13-6](#).
2. Playback the 315 Hz, -20 dB and 12.5 kHz to 63 Hz, -20 dB sections of test tape (QZZCFM) and then, using the 315 Hz, -20 dB playback

output as a reference (0 dB).

3. Confirm the playback frequency response is within the range shown in [Fig. 13-7](#).

Fig. 13-6.

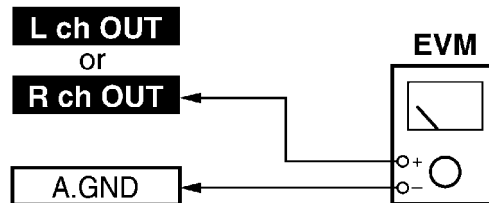
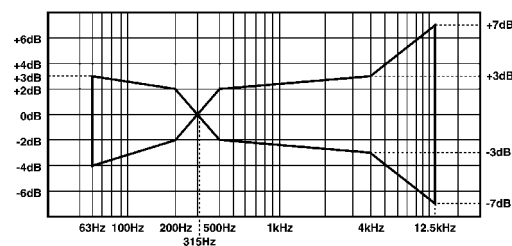

Fig. 13-7.



13.8. Recording/playback / frequency response and gain check (Deck 2)

13.8.1. Normal tape check

1. Connect the measuring instrument as shown in [Fig. 13-8](#).
2. Insert a Normal type blank tape (QZZCRA4) into Deck 2.
3. Record signals at 50 Hz, 100 Hz, 200 Hz, 500 Hz, 1 kHz, 2 kHz, 10 kHz and 12.5 kHz (28 mV).
4. Set the playback frequency of recorded signals at 1 kHz as a reference response (0 dB).
5. Playback the recorded signal to confirm that the output is within the range of the overall frequency response shown in [Fig. 13-9](#).

Fig. 13-8.

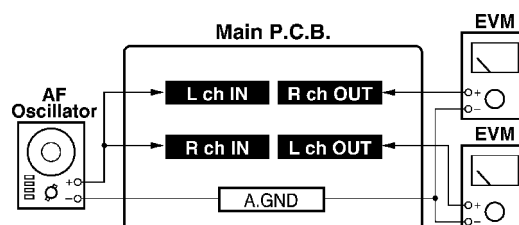
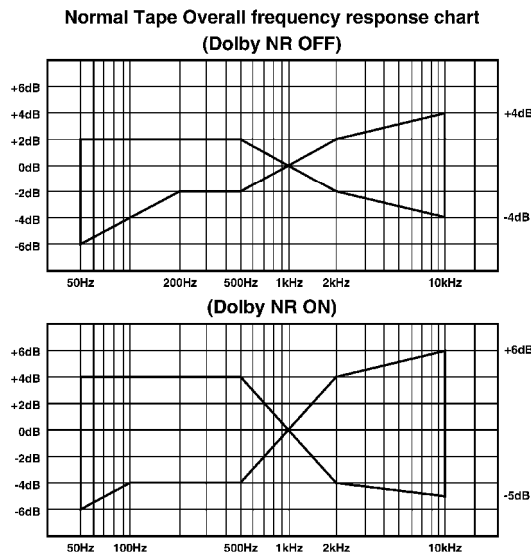

Fig. 13-9.



13.8.2. CrO₂/Metal tape check

1. Connect the measuring instrument as shown in [Fig. 13-8](#).
2. Insert a CrO₂/Metal tape into Deck 2.
3. Record signals at 50 Hz, 100 Hz, 200 Hz, 500 Hz, 1 kHz, 2 kHz, 10 kHz and 12.5 kHz (28 mV).
4. Set the playback frequency of recorded signals at 1 kHz as a reference response (0 dB).
5. Playback the recorded signal to confirm that the output is within the range of the overall frequency response shown in [Fig. 13-10](#).

Fig. 13-10.

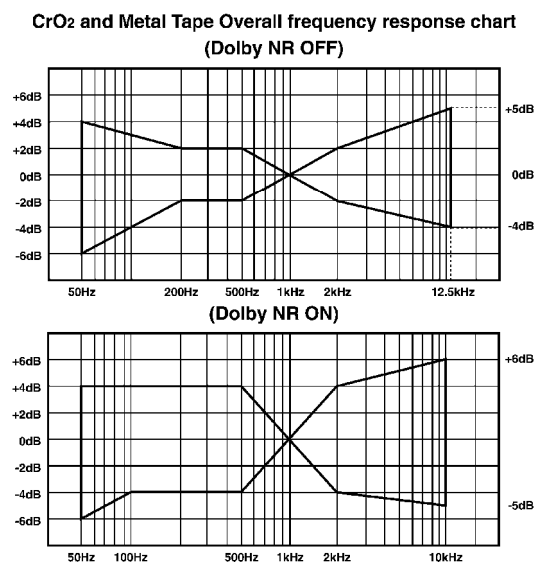

13.9. Adjustment point and test point

Fig. 13-11.

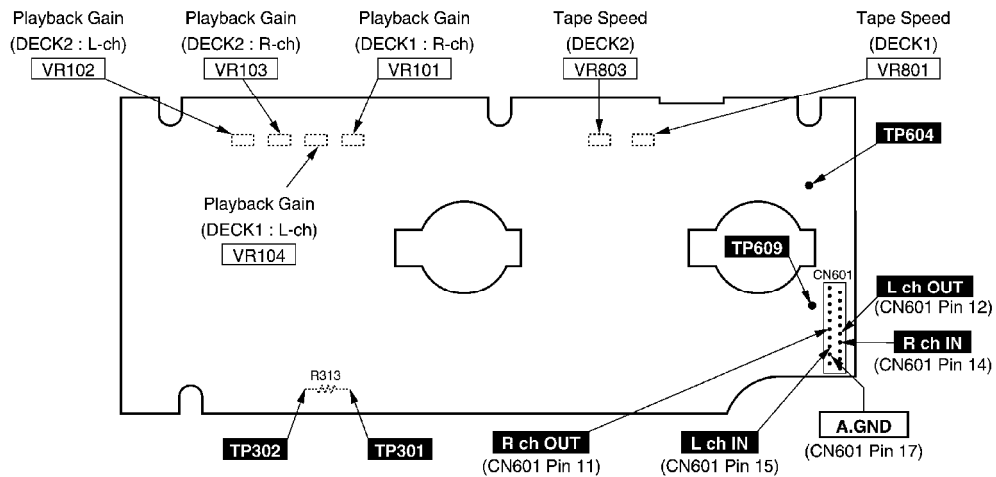

14. Checking Procedure for Self-operation of Cassette Mechanism Ass'y

- This procedure describes simple methods independent of mechanism controller or governor circuit.

14.1. Operation Check Providing with Cassette Tape

1. Push up the EJECT lever with rubber band. (Refer to [Fig. 14-2.](#))
2. Apply DC 5V to the MOTOR. (MOTOR will be rotated) (Refer to [Fig. 14-1.](#))
3. Provide the cassette tape with mechanism ass'y.
4. Apply DC 9V to the plunger, and then operate it by switching power ON/OFF. (Power: +PL, -PL) (Refer to [Fig. 14-1.](#))
 - A. FWD PLAY: Supply power to the plunger momentarily. (Duration: approx. 50msec.)
 - B. FWD FF: At FWD PLAY mode, supply power to the plunger momentarily. (Duration: approx. 50msec.)
 - C. STOP: At FWD FF mode, supply power to the plunger momentarily. (Duration: approx. 50msec.)
 - D. REV PLAY: At STOP mode, supply power to the plunger for ordinary duration. (Duration: approx. 200msec.)
 - E. REV REW: At REV PLAY mode, supply power to the plunger momentarily. (Duration: approx. 50msec.)
 - F. STOP: At REV REW mode, supply power to the plunger momentarily. (Duration: approx. 50msec.)

Repeat the above operation to FWD PLAY mode.

Note: Incorrect duration for power supply may be operated to other mode.

14.1.1. Connection Diagram Between the Mechanism Ass'y and Power Supply / (MOTOR and Plunger)

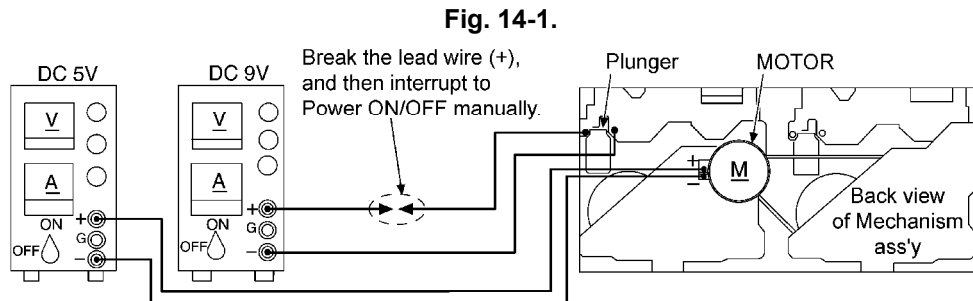

14.1.2. Detail View of EJECT Lever / (EJECT lever fixed by rubber band, Plunger rib operation)

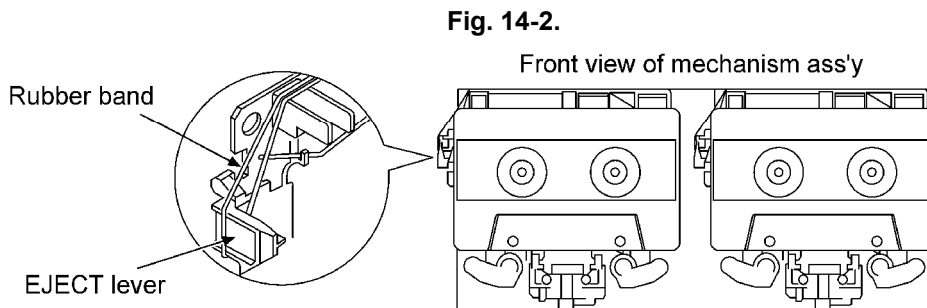

14.2. Operation Check Not Provided with Cassette Tape

1. Push up the EJECT lever with rubber band. (Refer to [Fig. 14-2.](#))
2. Apply DC 5V to the MOTOR. (MOTOR will be rotated)
3. Lift up the plunger rib of mechanism ass'y with the tip of minus screwdriver, and then operate it same as power supply duration. (Refer to [Fig. 14-3.](#))

Note: Operation order is same as the "Operation Check Providing with Cassette Tape" item 4. above.

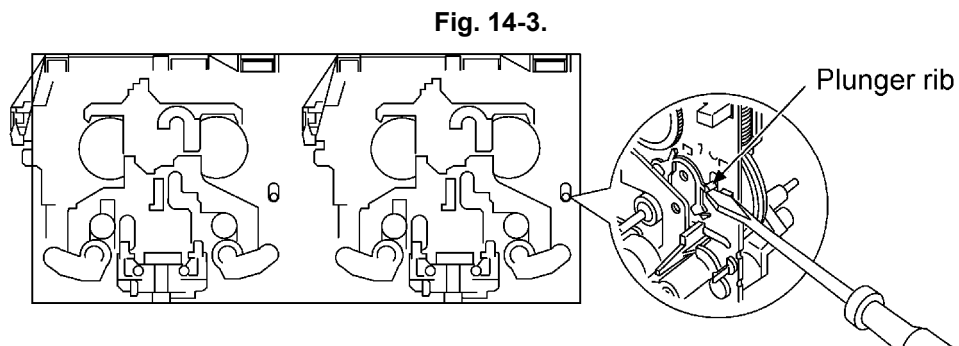

15. Replacement Parts List

Notes:

- Important safety notice:

Components identified by  mark have special characteristics important for safety.

Furthermore, special parts which have purposes of fire-retardant (resistors), high-quality sound (capacitors), low-noise (resistors), etc. are used.

When replacing any of components, be sure to use only manufacture's specified parts shown in the parts list.

- The marking [RTL] indicates the retention time is limited for this Item. After the discontinuation of this assembly in production, it will no longer available.

- All parts are supplied by SPC.

Ref. No.	Part No.	Part Name & Description	Pcs	Remarks
<u>1</u>	RKM0392-S1	CABINET	1	
<u>2</u>	RHD30007-1S	SCREW	4	
<u>3</u>	XTBS3+10JFZ1	SCREW	2	
<u>4</u>	RGR0287A-P	REAR PANEL	1	
<u>5</u>	RKA0105-K	RUBBER	4	
<u>6</u>	RKA0106-N	FOOT RING	4	
<u>7</u>	RMN0539	CABLE HOLDER	1	
<u>8</u>	RDG0129-1	DAMPER GEAR	2	
<u>9</u>	REX0966-1	WIRE ASS'Y	1	
<u>10</u>	RGB0025-A	TECHNICS BADGE	1	
<u>11</u>	RGK1131-2S	ORNAMENT(L)	1	
<u>12</u>	RGK1132-2S	ORNAMENT(R)	1	
<u>13</u>	RGL0441-Q	PANEL LIGHT	1	
<u>14</u>	REZ1194	WIRE ASS'Y	1	
<u>15</u>	RKF0462-K2	CASSETTE HOLDER(L)	1	
<u>16</u>	RKF0463-K2	CASSETTE HOLDER(R)	1	
<u>17</u>	RKF0587G-2S	CASSETTE LID(L)	1	
<u>18</u>	RKF0588-2S	CASSETTE LID(R)	1	
<u>19</u>	RKW0577-Q	CASSETTE WINDOW(L)	1	
<u>20</u>	RKW0578-Q	CASSETTE WINDOW(R)	1	
<u>21</u>	RMB0474	SPRING	2	
<u>22</u>	RMQ0577A-3	FRAME	1	
<u>23</u>	RUS757ZA	SPRING	4	
<u>24</u>	RYP1179-S	FRONT PANEL	1	
<u>25</u>	XTBS26+10J	SCREW	7	
<u>26</u>	XTB3+10JFZ	SCREW	5	
<u>27</u>	XTBS3+8JFZ1	SCREW	3	
<u>28</u>	RMG0161	RUBBER	1	

Ref. No.	Part No.	Part Name & Description	Pcs	Remarks
29	RMR0909-X	PCB HOLDER	1	
101	RED0037	HEAD BLOCK ASS'Y / (R/P)	1	L1AA00000008
101-1	RHD17015	SCREW	2	
102	RED0038	HEAD BLOCK ASS'Y / (P.B)	1	
102-1	RHD17015	SCREW	2	
103	RDG0300	REEL TABLE BASE	4	
104	RDG0301	GEAR	2	
105	RDK0026	GEAR	2	
107	RDV0033-4	BELT1	2	
108	RDV0034-1	BELT2	2	
110	RUW147ZA	SPRING	2	
111	RMB0400	SPRING	4	
112	RMB0403	SPRING	2	
113	RMB0404	SPRING	2	
114	RMB0406	SPRING	2	
115	RMB0408	SPRING	2	
116	RML0370-J	LEVER	2	
117	RML0371	LEVER	2	
118	RML0372	LEVER	2	
119	RML0374	LEVER	2	
120	RMM0131	ROD	2	
121	RMM0133-1	ROD	2	
122	RMQ0519	REEL CAP	4	
123	RMS0398-1	SHAFT	2	
124	RSJ0003	PLUNGER ASS'Y	2	
125	RUS609ZC	SPRING	2	
126	RXF0049	FLY WHEEL ASS'Y	2	
127	RXF0050	FLY WHEEL ASS'Y	2	
128	RXG0040	GEAR	4	
129	RMK0283A-J	SUB CHASSIS	2	
130	RXL0124	PINCH ROLLER ASS'Y	2	
130-1	RMB0401	SPRING	2	
131	RXL0125	PINCH ROLLER ASS'Y	2	
131-1	RMB0402	SPRING	2	
132	RXL0126	ARM GEAR	2	
133	RXQ0412	CHASSIS ASS'Y	2	
133-1	RMB0405	SPRING	2	
133-2	RMM0132-J	FR ROD	2	
134	REM0055-1	MOTOR ASS'Y	2	
135	RHD26022	SCREW	4	
136	XTW2+5L	SCREW	4	
137	XTW26+10S	SCREW	6	
138	XYC2+JF17	SCREW	2	
140	RFKJSCH770EK	MAIN CHASSIS ASS'Y	1	
C101-04	ECUV1H681KBN	50V 680P	4	F1J1H681A021
C109,10	ECQB1H183JF3	50V 0.018U	2	
C111,12	ECEA0JKS470	6.3V 47U	2	
C113,14	ECEA1HKS2R2	50V 2.2U	2	
C115,16	ECJ2VB1H471K	50V 470P	2	
C117,18	ECUX1H331KBX	50V 330P	2	
C119,20	ECA1HAK010XI	50V 1U	2	
C123,24	ECEA1EKS4R7	25V 4.7U	2	
C125,26	ECJ2VB1H332K	50V 3300P	2	

Ref. No.	Part No.	Part Name & Description	Pcs	Remarks
C129	ECEA1AKS220	10V 22U	1	
C130	F2A1C101A133	16V 100U	1	
C131-34	ECJ2VB1H471K	50V 470P	4	
C135,36	ECA1HAK010XI	50V 1U	2	
C137	ECEA1HKS0R1	50V 0.1U	1	
C138	F1J1E4730004	25V 0.047U	1	
C139	ECEA0JKS470	6.3V 47U	1	
C140	ECEA1CKS100	16V 10U	1	
C141	ECA1HAK010XI	50V 1U	1	
C142	ECUVNE104ZFN	25V 0.1U	1	F1J1E1040017
C143,44	ECJ2VB1H471K	50V 470P	2	
C150	RCE1AKA101BG	10V 100U	1	F2A1A1010020
C203,04	ECEA1EKS4R7	25V 4.7U	2	
C205,06	ECA1HAK010XI	50V 1U	2	
C207,08	ECUV1H271KBN	50V 270P	2	
C211,12	ECUV1H152KBN	50V 1500P	2	ECJ2VB1H152K
C213,14	ECEA1EKS4R7	25V 4.7U	2	
C215,16	ECEA1CKS100	16V 10U	2	
C217,18	ECEA1HKS0R1	50V 0.1U	2	
C219	F2A1C101A133	16V 100U	1	
C220	RCE1ARS471BJ	10V 470U	1	F2A1A471A111
C221,22	ECEA1HKAR68B	50V 0.68U	2	
C223	ECEA1EKS4R7	25V 4.7U	1	
C225,26	ECEA1EKS4R7	25V 4.7U	2	
C239,40	ECUV1H681KBN	50V 680P	2	F1J1H681A021
C241	ECJ2VB1H103K	50V 0.01U	1	
C301	ECA1CAM471XB	16V 470U	1	
C302	ECEA2AN2R2S	100V 2.2U	1	
C303	ECQP2E682JZT	250V 6800P	1	F0A2E682A002
C304	F2A1C101A133	16V 100U	1	
C305	ECEA1HKS0R1	50V 0.1U	1	
C306	ECQB1H393JF3	50V 0.039U	1	
C307	ECUV1H102KBN	50V 1000P	1	ECJ2VB1H102K
C308	ECJ2VB1H332K	50V 3300P	1	
C309	ECEA0JKS470	6.3V 47U	1	
C310,11	ECJ2VB1H103K	50V 0.01U	2	
C323	ECUV1H102KBN	50V 1000P	1	ECJ2VB1H102K
C602	ECA1CAM221XB	16V 220U	1	
C603	RCE1CKA470BG	16V 47U	1	F2A1C470A017
C604	ECUV1E103ZFN	25V 0.01U	1	F1J1E103A007
C605	ECA1CAM221XB	16V 220U	1	
C701	ECJ2VB1H103K	50V 0.01U	1	
C702	ECEA0JKS101	6.3V 100U	1	
C705	ECUV1E103ZFN	25V 0.01U	1	F1J1E103A007
C706	RCE1HKA3R3BG	50V 3.3U	1	F2A1H3R3A015
C707	ECUV1E103ZFN	25V 0.01U	1	F1J1E103A007
CN601	RJS2A5520-1	CONNECTOR(20P)	1	K1MP20A00005
CN901	RJS8T6ZA	CONNECTOR(8P)	1	K1MP08B00006
CP101,02	RJS1A6805	CONNECTOR(5P)	2	
CP901,02	RJT071K09A	CONNECTOR(9P)	2	K1KA09B00058
CS951	RJU071H09M	CONNECTOR(9P)	1	K1KB09C00001

Ref. No.	Part No.	Part Name & Description	Pcs	Remarks
CS971	RJU071H09M	CONNECTOR(9P)	1	K1KB09C00001
D101,02	MA2J11100L	DIODE	2	
D301	MA2J11100L	DIODE	1	
D606	MAZ40560MF	DIODE	1	
D651,52	MA165TA5	DIODE	2	MA2C16500E
D701	MA2J11100L	DIODE	1	
D705,06	MA2J11100L	DIODE	2	
D707	MA4051M	DIODE	1	MAZ40510M
D708-10	MA2J11100L	DIODE	3	
D904	MA2J11100L	DIODE	1	
D905	B3AHA0000012	LED	1	
D907	B3AHA0000012	LED	1	
D951	MA165TA5	DIODE	1	MA2C165
D971	MA165TA5	DIODE	1	MA2C165
IC101	CXA1998BQT6	IC	1	C1BB00000319
IC102	MC14066BFEL	IC	1	C0JBAR000248
IC103	BA7755AF	IC	1	C1AB00001381
IC201	CXA1552M-T4	IC	1	C1BB00000311
IC202	MC14066BFEL	IC	1	C0JBAR000248
IC701	M38503M2406F	IC	1	C2BBDD000003
IC951	0N2180RLC1	IC	1	
IC971	0N2180RLC1	IC	1	
L201,02	ELELN103KA	COIL	2	
L301	RL08B006-K	COIL	1	G2A142C00002
L302	RLQZB101KT-D	COIL	1	G0C101K00017
L701	G0C100JA0019	COIL	1	
L702	J0JBC0000041	COIL	1	
PCB1	REP2827E-M	MAIN P.C.B.	1	[RTL]
PCB2	REPX0108A	MECHA.SW.P.C.B. / (P.B.)	1	[RTL]
PCB3	REPX0108B	MECHA.SW.P.C.B. / (R/P)	1	[RTL]
Q101,02	2SJ164RTA	TRANSISTOR	2	2SJ01640RA
Q103,04	2SJ164QTA	TRANSISTOR	2	2SJ01640QA
Q105,06	2SD1819ARTX	TRANSISTOR	2	2SD1819ARL
Q107	DTA143EUT106	TRANSISTOR	1	B1GDCFGG0008
Q108	DTC143EUT106	TRANSISTOR	1	B1GBCFGG0006
Q201,02	DTA143EUT106	TRANSISTOR	2	B1GDCFGG0008
Q301	2SD1819ARTX	TRANSISTOR	1	2SD1819ARL
Q302	2SD1328STW	TRANSISTOR	1	2SD13280S2RA
Q303,04	2SD14500HA	TRANSISTOR	2	
Q305,06	DTC144EUT106	TRANSISTOR	2	B1GBCFNN0013
Q602	2SD2144S	TRANSISTOR	1	B1AAGC000006
Q604	2SC3940AQSTA	TRANSISTOR	1	2SC3940ARA
Q701-03	2SD1819ARTX	TRANSISTOR	3	2SD1819ARL
Q706	DTC114EUT106	TRANSISTOR	1	B1GBCFJJ0009
Q803,04	2SD592AR	TRANSISTOR	2	2SD0592AR
Q805,06	DTA143EUT106	TRANSISTOR	2	B1GDCFGG0008
Q807,08	2SB0621AHA	TRANSISTOR	2	
Q809,10	DTC143EUT106	TRANSISTOR	2	B1GBCFGG0006
Q901	DTA143EUT106	TRANSISTOR	1	B1GDCFGG0008

Ref. No.	Part No.	Part Name & Description	Pcs	Remarks
Q902-04	DTC143EUT106	TRANSISTOR	3	B1GBCFGG0006
R101,02	ERJ6GEYJ562V	1/10W 5.6K	2	
R103,04	ERJ6GEYJ104V	1/10W 100K	2	
R105,06	ERJ6GEYJ334V	1/10W 330K	2	
R107,08	ERJ6GEYJ103V	1/10W 10K	2	
R109,10	ERJ6GEYJ102V	1/10W 1K	2	
R111	ERJ6GEYJ820V	1/10W 82	1	D0GD820JA012
R112	ERJ8GEYJ820V	1/8W 82	1	
R113	ERJ6GEYJ123V	1/10W 12K	1	
R114	ERJ6GEYJ273V	1/10W 27K	1	
R117	ERJ6GEYJ102V	1/10W 1K	1	
R118,19	ERDS2FJ220	1/4W 22	2	
R120	ERJ6GEYJ104V	1/10W 100K	1	
R121,22	ERJ6GEYJ103V	1/10W 10K	2	
R125	ERJ6GEYJ104V	1/10W 100K	1	
R126	ERJ6GEYJ223V	1/10W 22K	1	
R127	ERJ6GEYJ472V	1/10W 4.7K	1	
R130	ERJ6GEYJ475V	1/10W 4.7M	1	
R131	ERJ6GEYJ334V	1/10W 330K	1	
R132	ERJ6GEYJ273V	1/10W 27K	1	
R133	ERJ6GEYJ333V	1/10W 33K	1	
R134	ERJ6GEYJ392V	1/10W 3.9K	1	
R135	ERJ6GEYJ682V	1/10W 6.8K	1	
R136,37	ERJ6GEYJ222V	1/10W 2.2K	2	
R138	ERJ6GEYJ472V	1/10W 4.7K	1	
R139,40	ERJ6GEYF473	1/10W 47K	2	
R141	ERJ8GEYJ101V	1/8W 100	1	
R142	ERJ6GEYJ101V	1/10W 100	1	
R143	ERDS2FJ101	1/4W 100	1	
R144	ERJ6GEYJ101V	1/10W 100	1	
R147-50	ERJ6GEYJ562V	1/10W 5.6K	4	
R151,52	ERJ6GEYJ104V	1/10W 100K	2	
R153,54	ERJ6GEYJ272V	1/10W 2.7K	2	
R157,58	ERJ6GEYJ223V	1/10W 22K	2	
R207,08	ERJ6GEYF473	1/10W 47K	2	
R209,10	ERJ6GEYJ102V	1/10W 1K	2	
R211,12	ERJ6GEYJ103V	1/10W 10K	2	
R213,14	ERJ6GEYJ302V	1/10W 3K	2	
R215,16	ERJ6GEYJ123V	1/10W 12K	2	
R217,18	ERJ6GEYJ222V	1/10W 2.2K	2	
R219	ERJ6GEYJ183V	1/10W 18K	1	
R220	ERDS2FJ220	1/4W 22	1	
R221,22	ERJ6GEYJ101V	1/10W 100	2	
R223,24	ERJ6GEYJ103V	1/10W 10K	2	
R225,26	ERJ6GEYF473	1/10W 47K	2	
R230,31	ERJ6GEYJ102V	1/10W 1K	2	
R232	ERJ6GEYJ103V	1/10W 10K	1	
R233,34	ERJ6GEYJ101V	1/10W 100	2	
R237	ERDS2FJ220	1/4W 22	1	
R301	ERJ6GEYJ103V	1/10W 10K	1	
R302	ERJ6GEYJ182V	1/10W 1.8K	1	
R303	ERJ6GEYJ222V	1/10W 2.2K	1	
R304	ERJ6GEYJ153V	1/10W 15K	1	

Ref. No.	Part No.	Part Name & Description	Pcs	Remarks
R305	ERJ6GEYJ183V	1/10W 18K	1	
R306	ERJ6GEYJ333V	1/10W 33K	1	
R307	ERDS1FJ2R2	1/2W 2.2	1	
R308	ERJ6GEYJ102V	1/10W 1K	1	
R309-11	ERJ6GEYJ472V	1/10W 4.7K	3	
R313	ERDS2TJ1R0	1/4W 1.0	1	
R602	ERQ16NKWR33E	1/6W 0.33	1	
R603	ERD2FCG100	1/4W 10	1	
R604	ERJ6GEYJ331V	1/10W 330	1	
R606	ERJ6GEYJ152V	1/10W 1.5K	1	
R609	ERDS2FJ101	1/4W 100	1	
R630	ERQ16NKWR33E	1/6W 0.33	1	
R632	ERDS2FJ473	1/4W 47K	1	
R701,02	ERJ6GEYJ103V	1/10W 10K	2	
R703	ERJ6GEYJ562V	1/10W 5.6K	1	
R704	ERJ6GEYJ472V	1/10W 4.7K	1	
R705	ERJ6GEYF473	1/10W 47K	1	
R708	ERJ6GEYJ472V	1/10W 4.7K	1	
R710	ERJ6GEYJ102V	1/10W 1K	1	
R711	ERJ6GEYJ104V	1/10W 100K	1	
R712	ERJ8GEYJ683V	1/8W 68K	1	
R718	ERJ8GEYJ683V	1/8W 68K	1	
R721	ERJ6GEYJ472V	1/10W 4.7K	1	
R722	ERJ6GEYJ101V	1/10W 100	1	
R723,24	ERJ6GEYJ102V	1/10W 1K	2	
R725,26	ERJ6GEYJ222V	1/10W 2.2K	2	
R727	ERJ6GEYJ472V	1/10W 4.7K	1	
R728	ERJ6GEYJ103V	1/10W 10K	1	
R729	ERJ6GEYJ472V	1/10W 4.7K	1	
R730	ERJ6GEYJ222V	1/10W 2.2K	1	
R732	ERJ6GEYJ104V	1/10W 100K	1	
R735	ERJ6GEYJ472V	1/10W 4.7K	1	
R736	ERJ6GEYJ103V	1/10W 10K	1	
R737	ERJ8GEYJ103V	1/8W 10K	1	
R738	ERJ6GEYJ102V	1/10W 1K	1	
R741	ERJ6GEYJ223V	1/10W 22K	1	
R743	ERJ6GEYF473	1/10W 47K	1	
R744	ERJ6GEYJ102V	1/10W 1K	1	
R745	ERJ6GEYJ101V	1/10W 100	1	
R747	ERJ8GEYJ102V	1/8W 1K	1	
R802	ERJ6GEYJ561V	1/10W 560	1	
R803	ERJ6GEYJ103V	1/10W 10K	1	
R805	ERJ6GEYJ392V	1/10W 3.9K	1	
R806	ERJ6GEYJ103V	1/10W 10K	1	
R808	ERJ6GEYJ392V	1/10W 3.9K	1	
R810,11	ERJ6GEYJ103V	1/10W 10K	2	
R812	ERJ6GEYJ561V	1/10W 560	1	
R813,14	ERJ6GEYJ471V	1/10W 470	2	
R818	ERDS2FJ2R2	1/4W 2.2	1	
R820	ERDS2FJ2R2	1/4W 2.2	1	
R823,24	ERJ6GEYJ561V	1/10W 560	2	
R900	ERJ6GEYJ821V	1/10W 820	1	
R901	ERJ6GEYJ102V	1/10W 1K	1	
R902	ERJ6GEYJ122V	1/10W 1.2K	1	D0GD122JA003

Ref. No.	Part No.	Part Name & Description	Pcs	Remarks
R903	ERJ6GEYJ152V	1/10W 1.5K	1	
R904	ERJ6GEYJ182V	1/10W 1.8K	1	
R905	ERJ6GEYJ222V	1/10W 2.2K	1	
R906	ERJ6GEYJ332V	1/10W 3.3K	1	D0GD332JA003
R908	ERJ6GEYJ122V	1/10W 1.2K	1	D0GD122JA003
R909	ERJ6GEYJ152V	1/10W 1.5K	1	
R910	ERJ6GEYJ182V	1/10W 1.8K	1	
R911	ERJ6GEYJ222V	1/10W 2.2K	1	
R914	ERJ6GEYJ331V	1/10W 330	1	
R915	ERJ6GEYJ681V	1/10W 680	1	
R916	ERJ6GEYJ331V	1/10W 330	1	
R917	ERJ6GEYJ681V	1/10W 680	1	
R924	ERJ6GEYJ821V	1/10W 820	1	
R925	ERJ6GEYJ102V	1/10W 1K	1	
R952	ERDS2FJ821	1/4W 820	1	
R953	ERDS2FJ393	1/4W 39K	1	
R972	ERDS2FJ821	1/4W 820	1	
R973	ERDS2FJ393	1/4W 39K	1	
RJ504	ERJ6GEY0R00V	CHIP JUMPER	1	
RJ507-09	ERJ8GEY0R00V	CHIP JUMPER	3	D0YFR0000002
S900,01	EVQ11G05R	SW,PUSH	2	
S903-07	EVQ11G05R	SW,PUSH	5	
S909-15	EVQ11G05R	SW,PUSH	7	
S951	RSH1A018-3U	SW,MECHA DET	1	
S952,53	RSH1A019-2U	SW,MECHA DET	2	
S971	RSH1A018-3U	SW,MECHA DET	1	
S972-76	RSH1A019-2U	SW,MECHA DET	5	
VR101-04	EVNDCAA03B24	V.R.,PLAYBACK GAIN / ADJ.	4	
VR801	EVNDCAA03B53	V.R.,TAPE SPEED / ADJ.	1	
VR803	EVNDCAA03B53	V.R.,TAPE SPEED / ADJ.	1	
X701	RSXY8M00D01T	OSCILLATOR	1	H2B800400005
Z971	EXBF7L355SYV	COMPONENT / COMBINATION	1	

16. Cabinet Parts Location

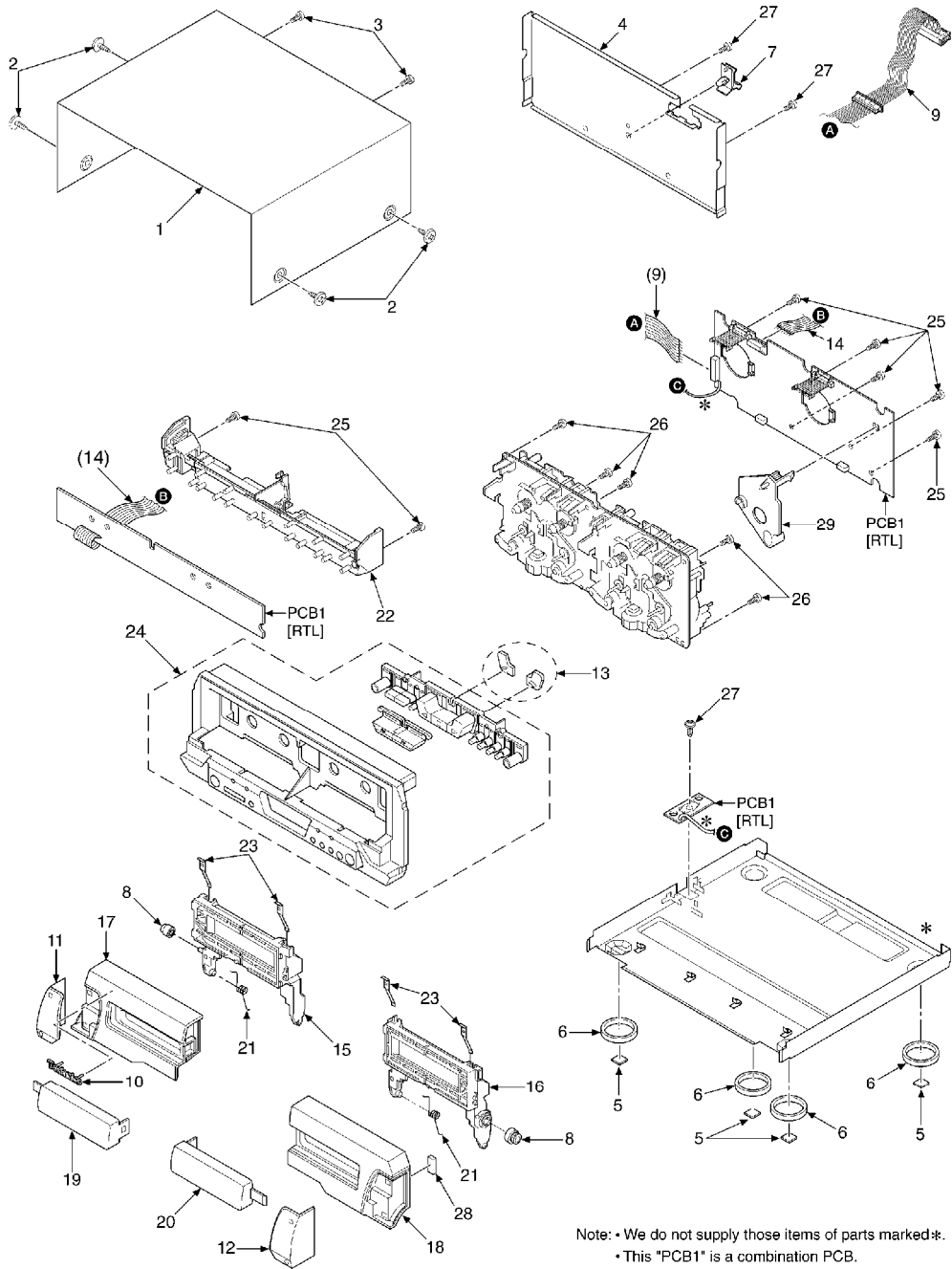

17. Mechanism Parts Location

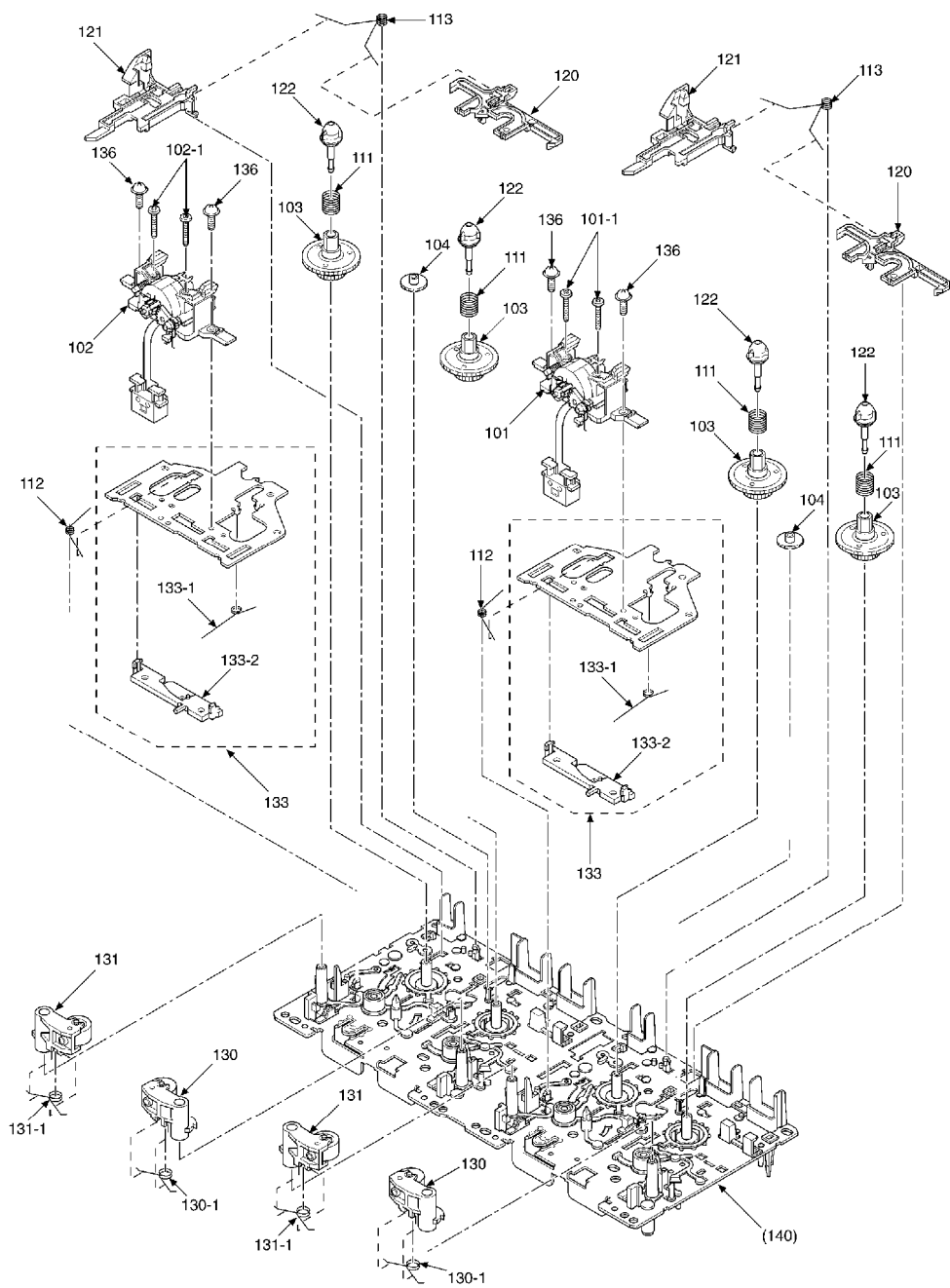

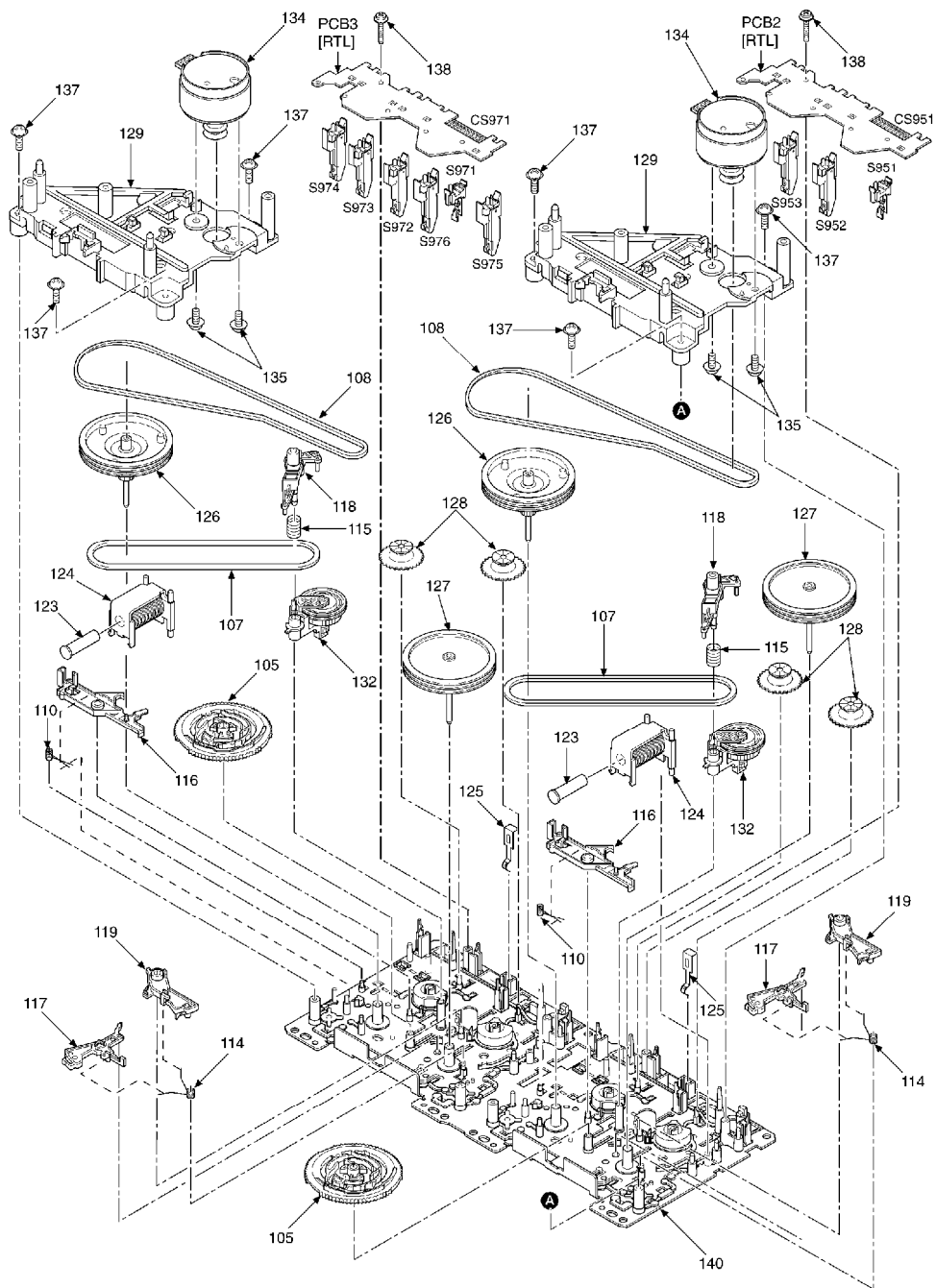

18. Schematic Diagram for printing with letter size F0302KH

E OPERATION CIRCUIT

→ : POSITIVE VOLTAGE LINE
 ⇨ : PLAYBACK SIGNAL LINE

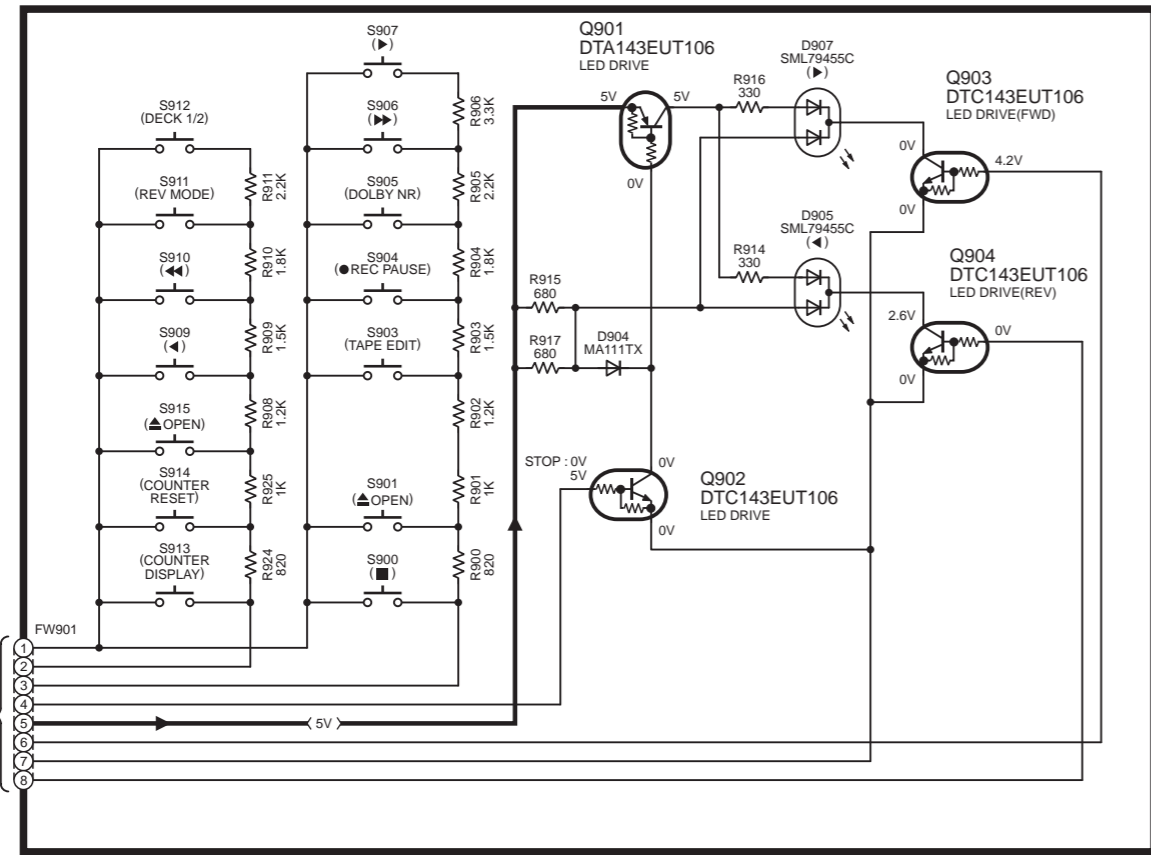

A MAIN CIRCUIT

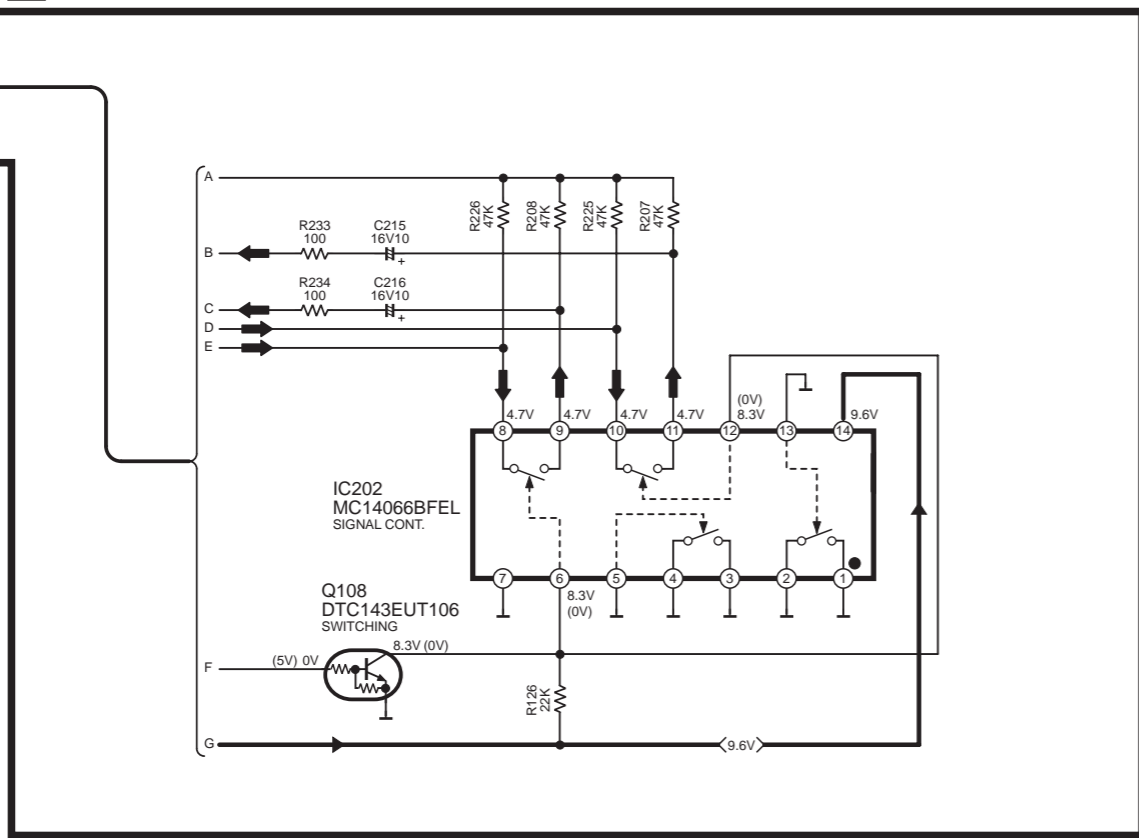

RS-DV290(EG) OPERATION, MAIN CIRCUIT DIAGRAM

A MAIN CIRCUIT

→ : POSITIVE VOLTAGE LINE ⇨ : RECORDING SIGNAL LINE ⇩ : PLAYBACK SIGNAL LINE

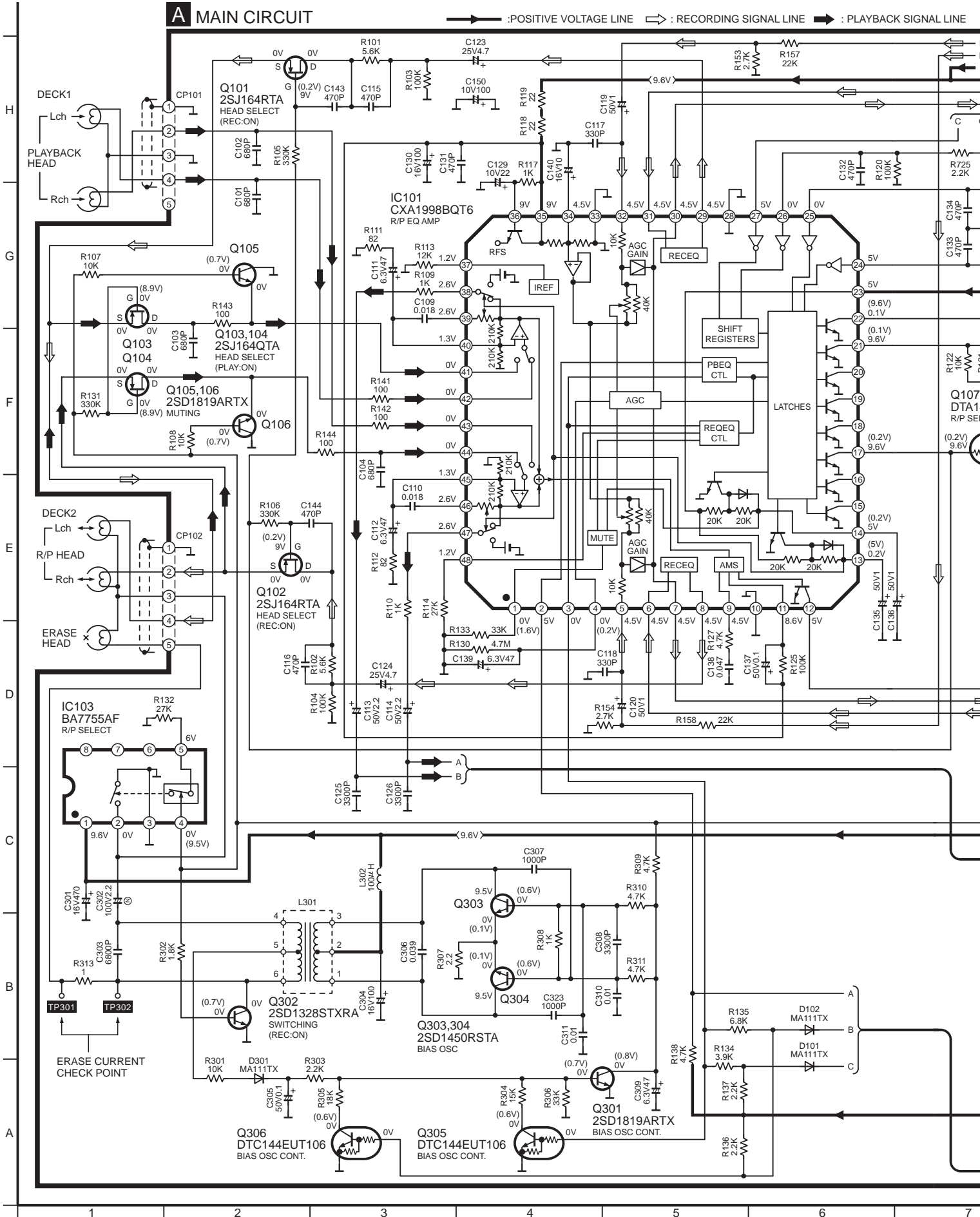

▶ : PLAYBACK SIGNAL LINE

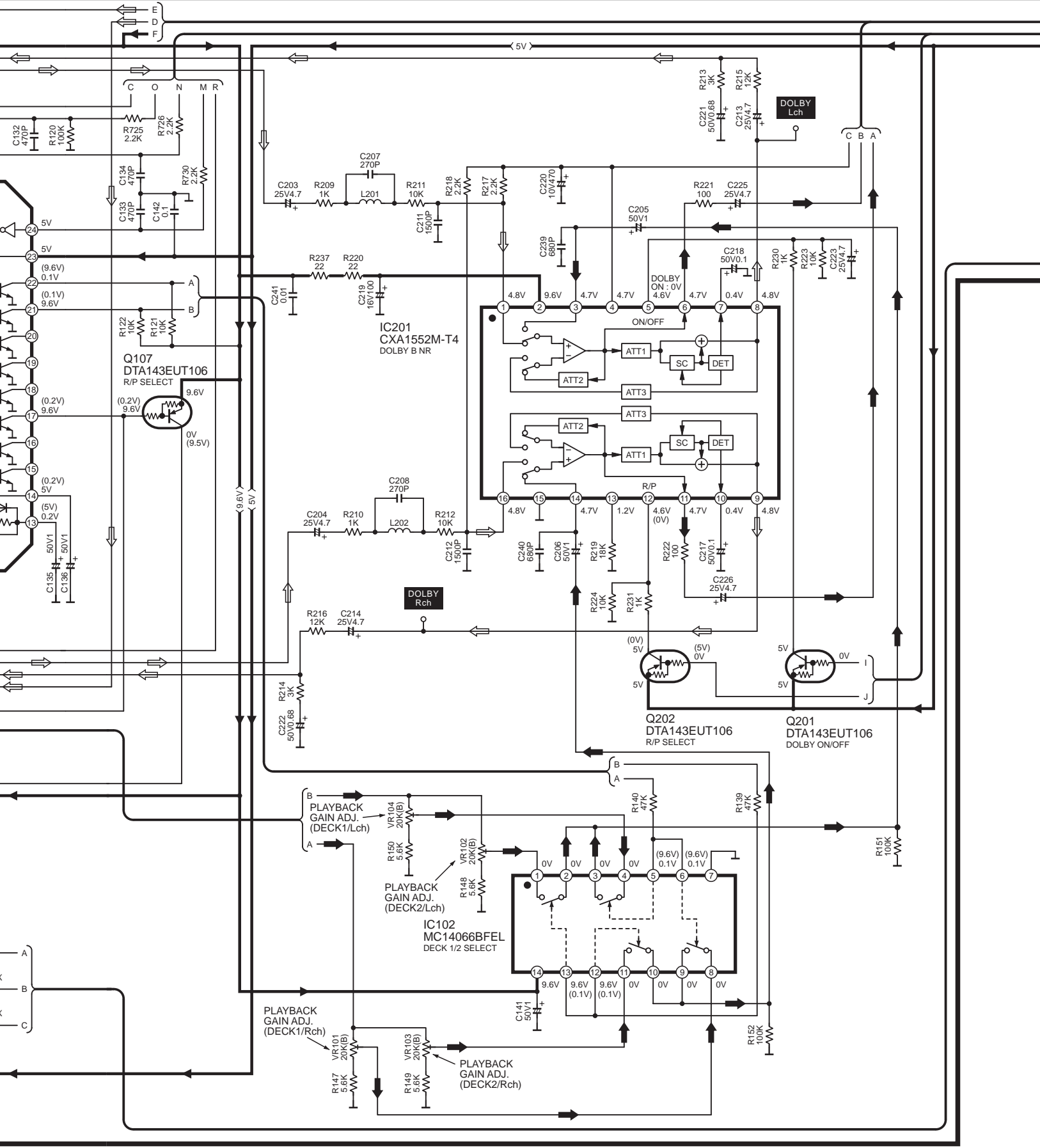

RS-DV290(EG) MAIN CIRCUIT DIAGRAM

A MAIN CIRCUIT

→ : POSITIVE VOLTAGE LINE ⇨ : RECORDING SIGNAL LINE ⇩ : PLAYBACK SIGNAL LINE

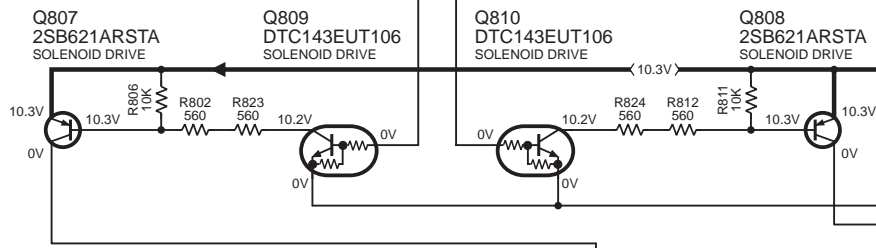

B MECHANISM CIRCUIT (DECK1)

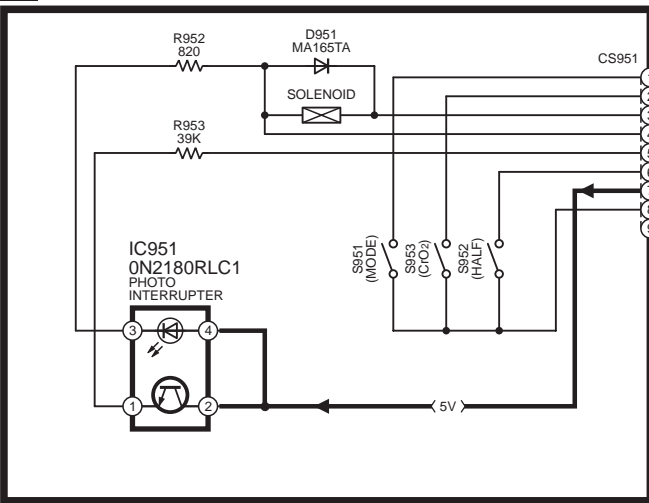

C MECHANISM CIRCUIT (DECK2)

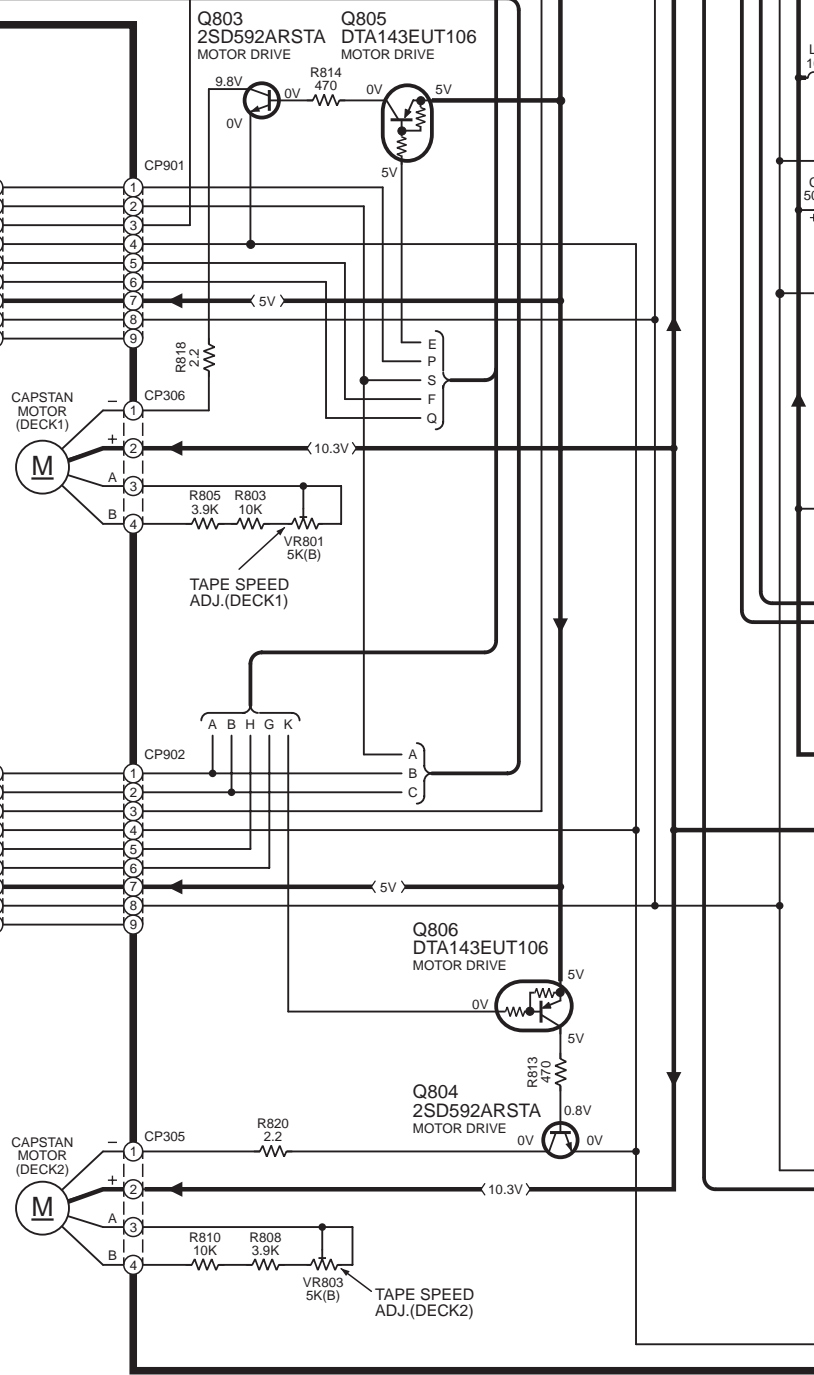
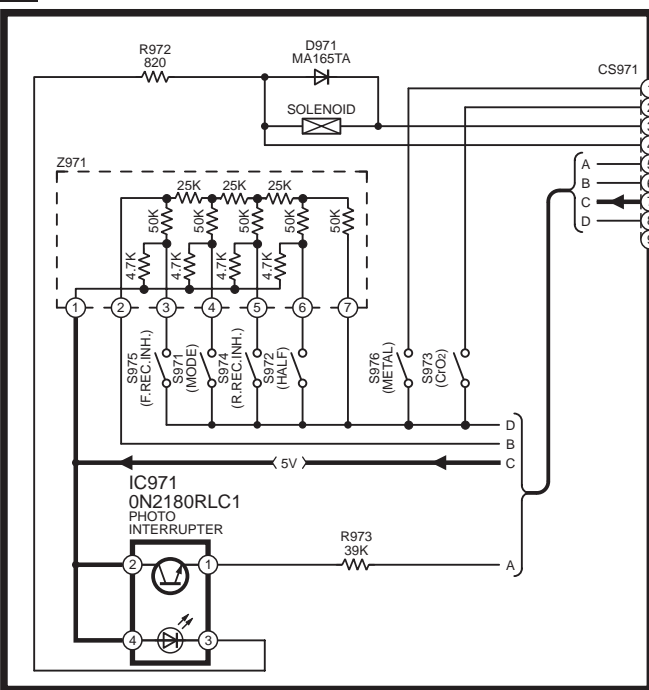

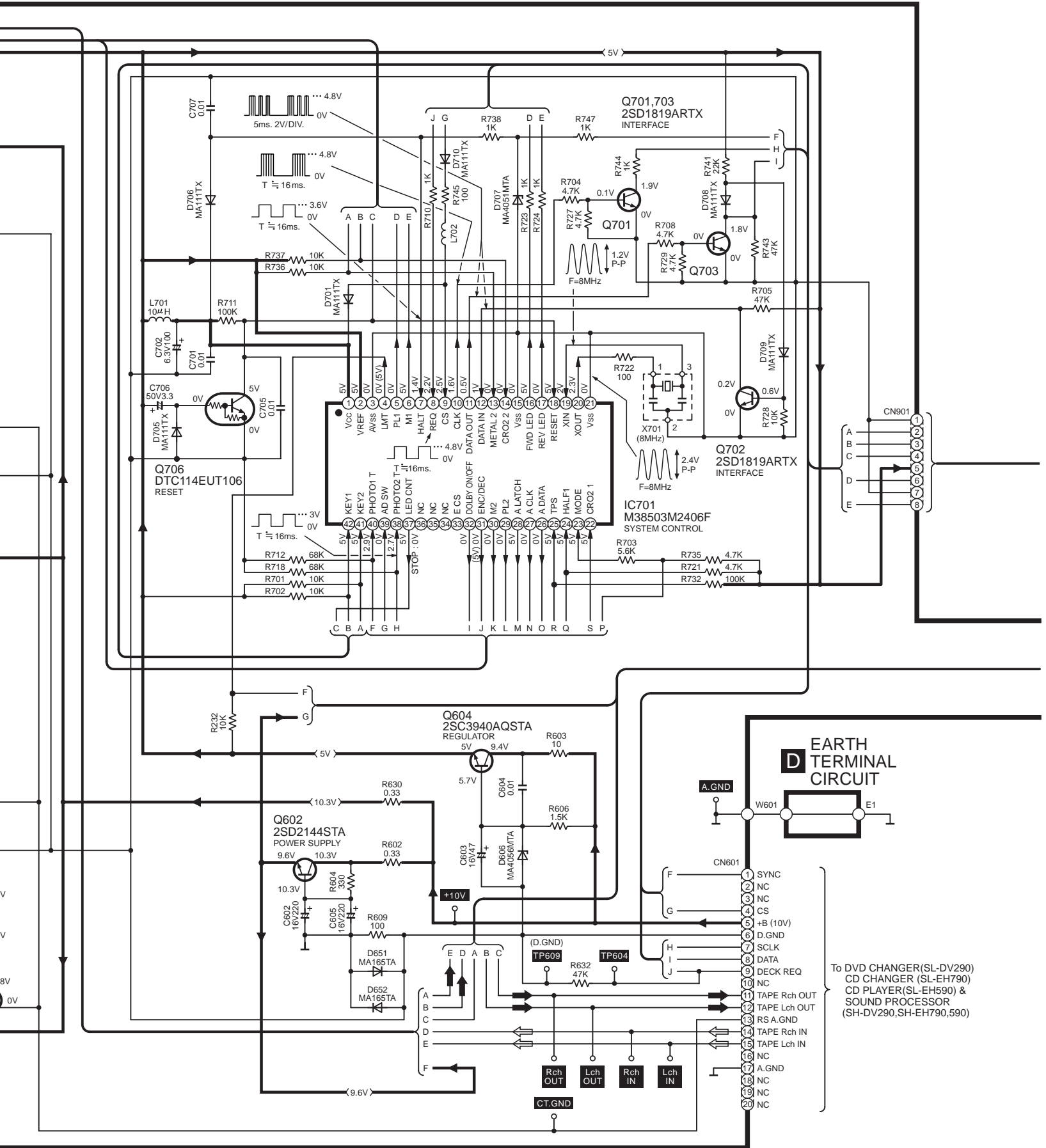

EARTH TERMINAL CIRCUIT

- CN601
- 1 SYNC
 - 2 NC
 - 3 NC
 - 4 CS
 - 5 +B (10V)
 - 6 D.GND
 - 7 SCLK
 - 8 DATA
 - 9 DECK REQ
 - 10 NC
 - 11 TAPE Rch OUT
 - 12 TAPE Lch OUT
 - 13 RS A.GND
 - 14 TAPE Rch IN
 - 15 TAPE Lch IN
 - 16 NC
 - 17 A.GND
 - 18 NC
 - 19 NC
 - 20 NC

To DVD CHANGER (SL-DV290)
 CD CHANGER (SL-EH790)
 CD PLAYER (SL-EH590) &
 SOUND PROCESSOR
 (SH-DV290, SH-EH790, 590)

RS-DV290(EG) MAIN, MECHANISM (DECK1, 2), EARTH TERMINAL CIRCUIT DIAGRAM

E OPERATION CIRCUIT

→ : POSITIVE VOLTAGE LINE → : PLAYBACK SIGNAL LINE

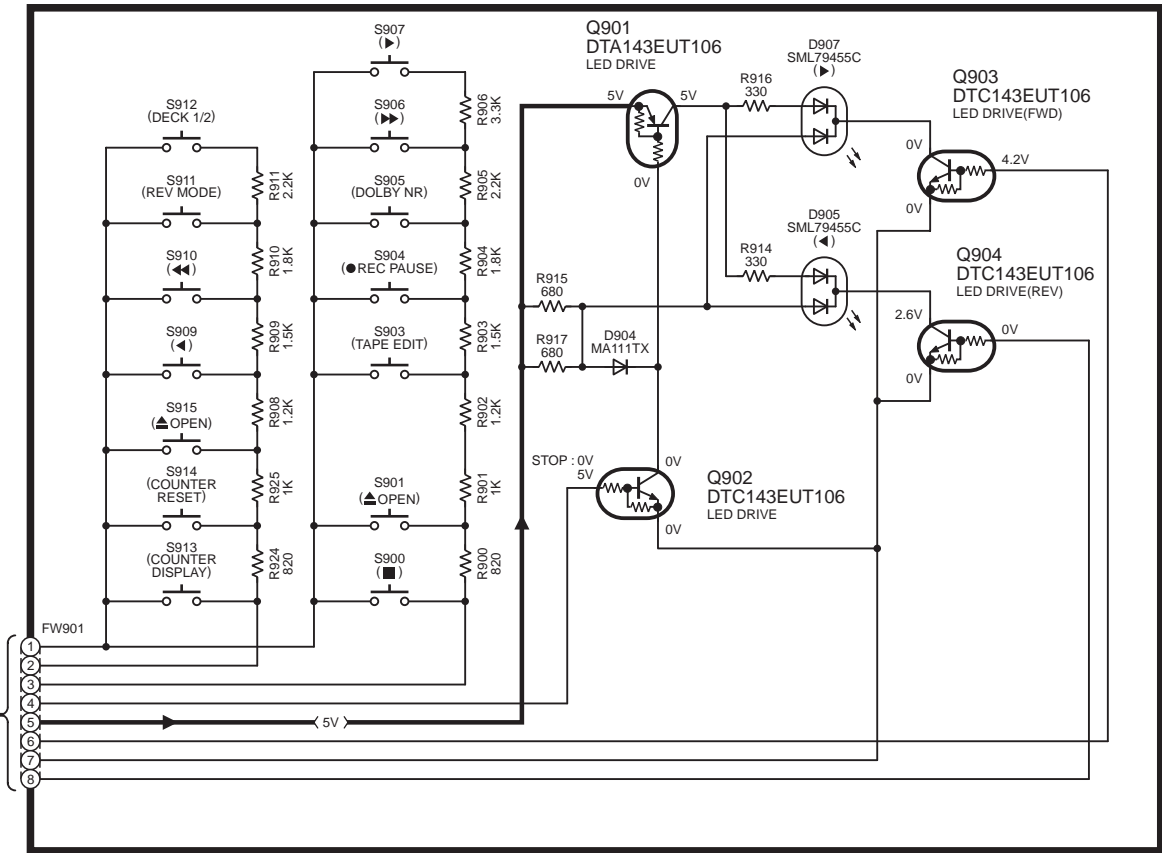

A MAIN CIRCUIT

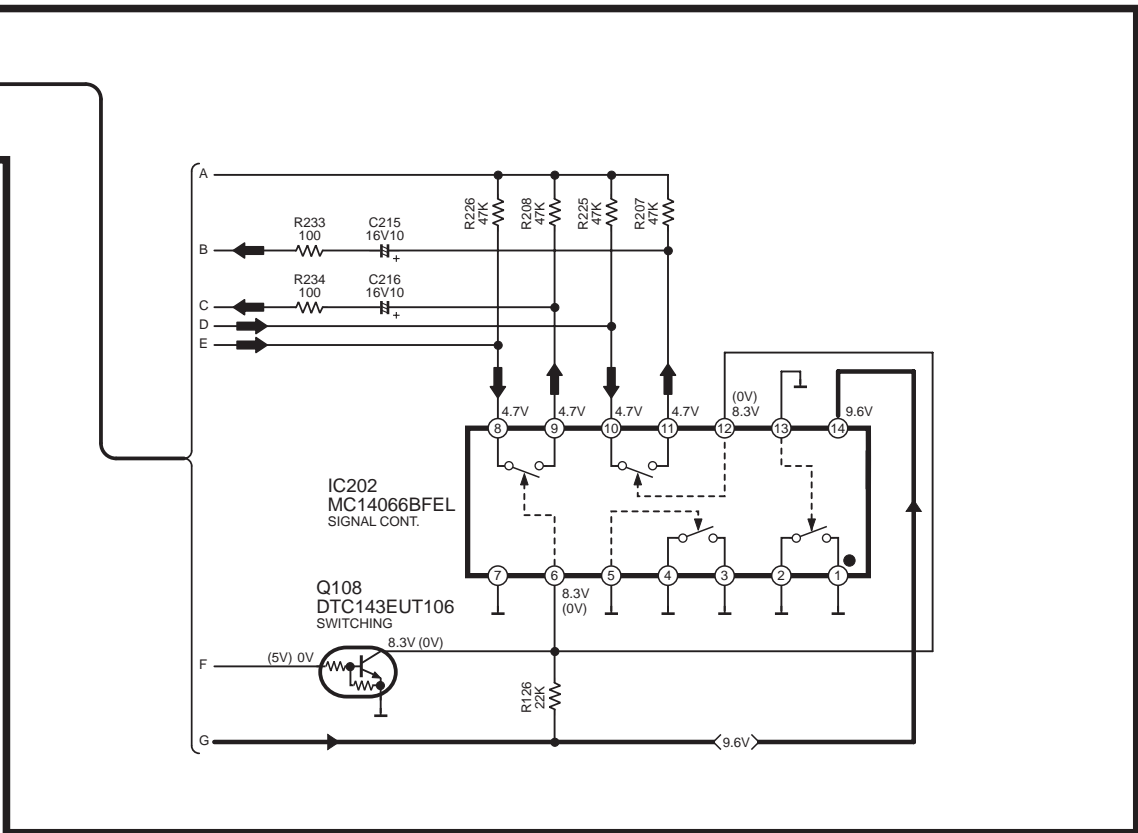

RS-DV290(EG) OPERATION, MAIN CIRCUIT DIAGRAM



H

G

F

E

D

C

B

A

30 | 31 | 32 | 33 | 34 | 35 | 36



CXA1552M-T4	16PIN
MC14066BFEL	14PIN
M38503M2406F	42PIN

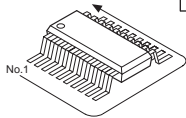

BA7755AF

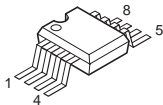

CXA1998BQT6

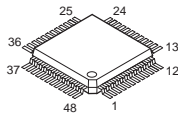

0N2180RLC1

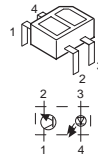

2SD1450RSTA



2SB621ARSTA
2SD592ARSTA

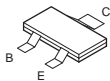
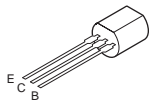

2SD1819ARTX
2SD1328STXRA
DTA143EUT106
DTC114EUT106
DTC143EUT106
DTC144EUT106

2SC3940AQSTA

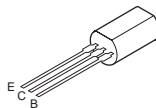

2SD2144STA

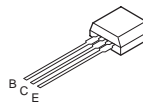

2SJ164QTA
2SJ164RTA

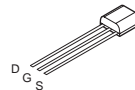

MA165TA

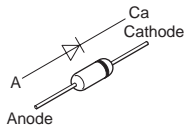

MA4051MTA
MA4056MTA

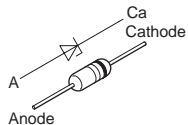

SML79455C

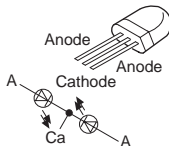

MA111TX

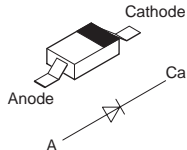

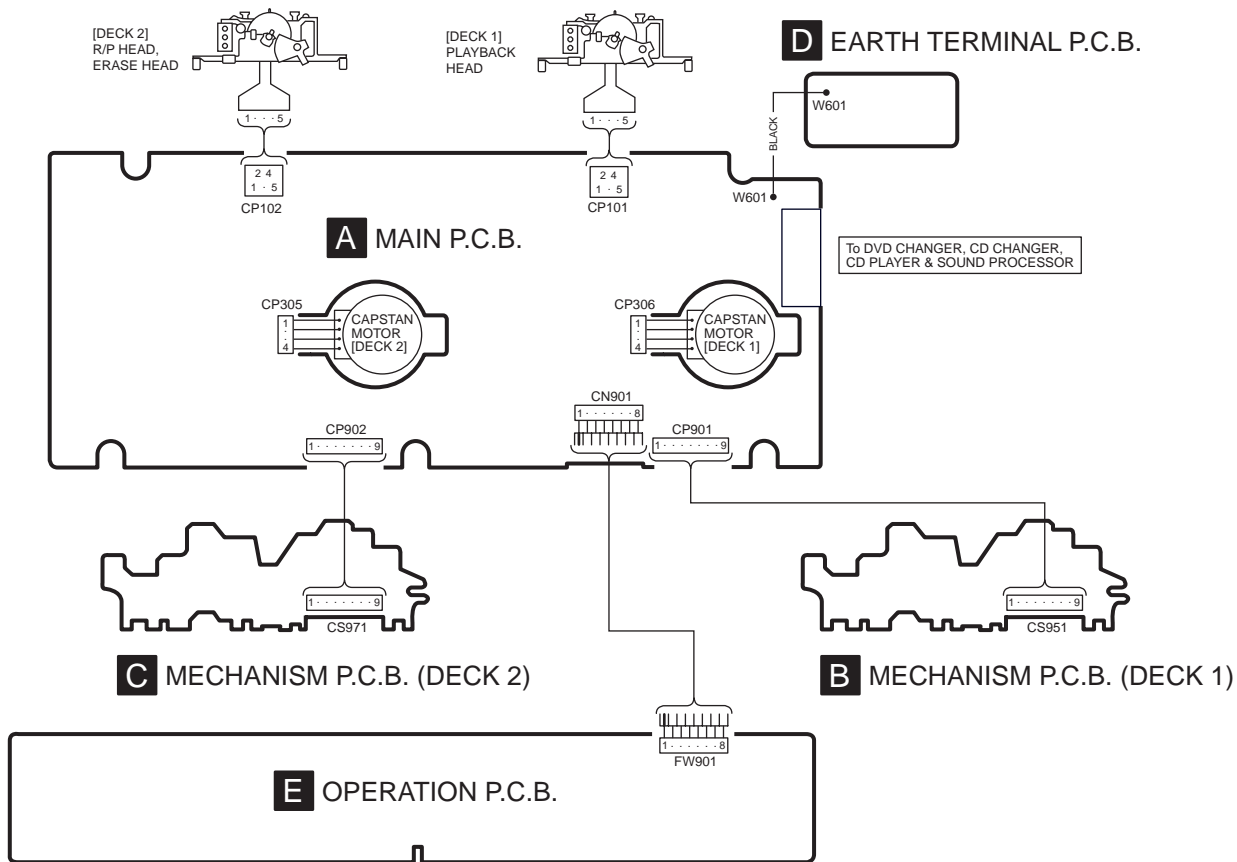

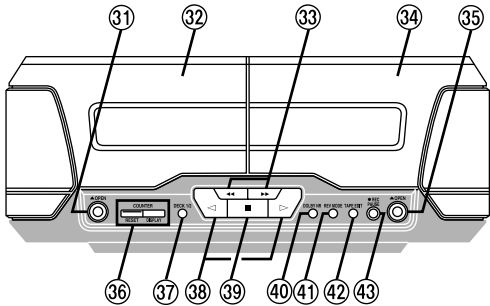

③① Deck 1 cassette holder open button (\blacktriangle OPEN)

③② Deck 1

③③ Fast forward/rewind, TPS buttons (\ll , \gg)

③④ Deck 2

③⑤ Deck 2 cassette holder open button (\blacktriangle OPEN)

③⑥ Counter reset, display buttons
(COUNTER, RESET, DISPLAY)

③⑦ Deck 1/deck 2 select button (DECK 1/2)

③⑧ Playback buttons and indicators (\triangleleft , \triangleright)

The colour of the indicators depends on the operation taking place.

If stopped, fast forwarding or rewinding: orange

If playing or recording: green

While carrying out TPS or recording is on standby: flashes

③⑨ Stop button (\blacksquare)

④① Dolby noise reduction button (DOLBY NR)

④② Reverse mode button (REV MODE)

④③ Tape edit button (TAPE EDIT)

④④ Record pause button (\bullet REC PAUSE)

NOTES

- → : PLAYBACK SIGNAL LINE
- ⇨ : RECORDING SIGNAL LINE
- () indicates pin No. Right channel.

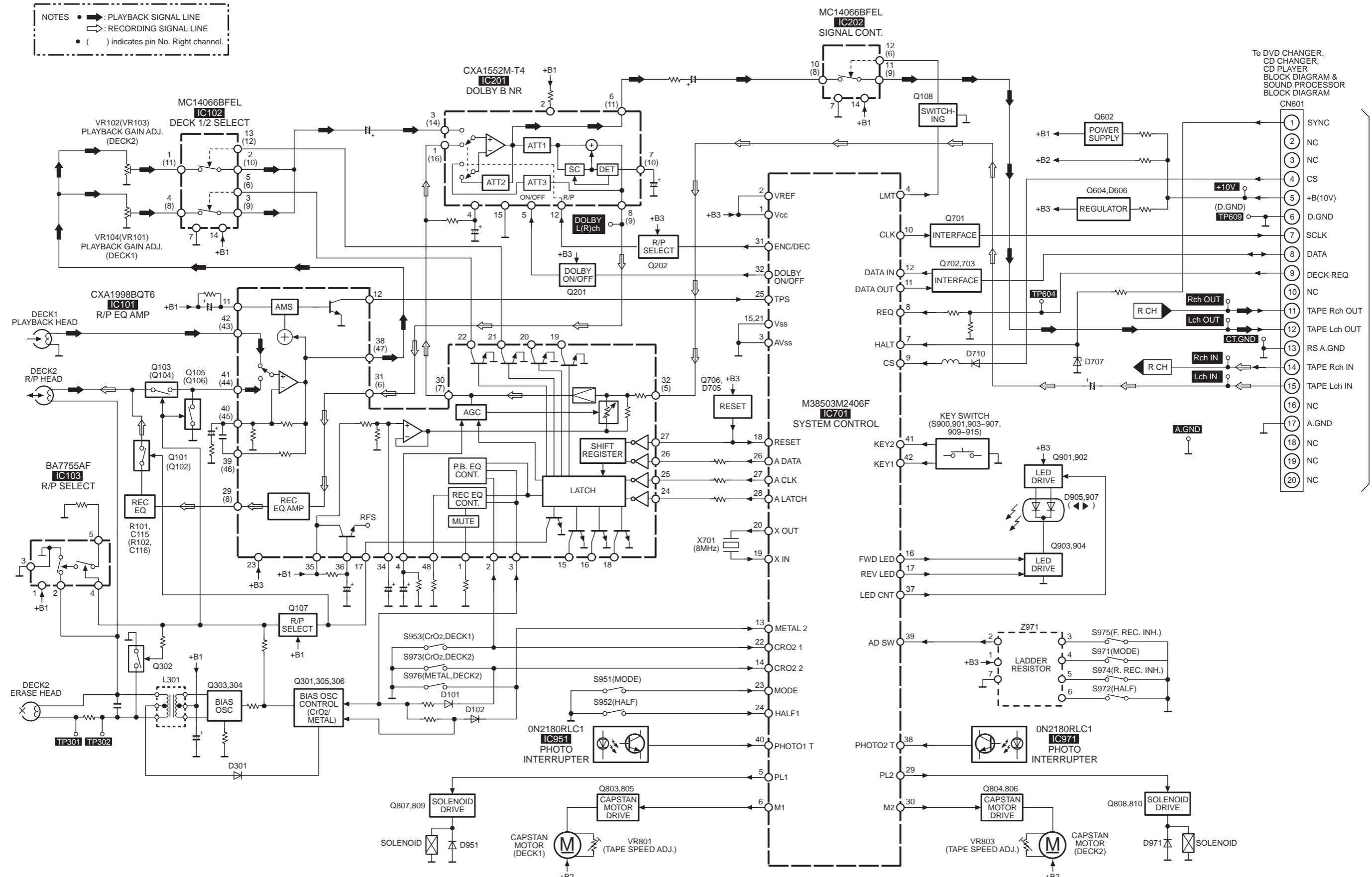

A MAIN CIRCUIT

→ : POSITIVE VOLTAGE LINE ⇨ : RECORDING SIGNAL LINE ⇩ : PLAYBACK SIGNAL LINE

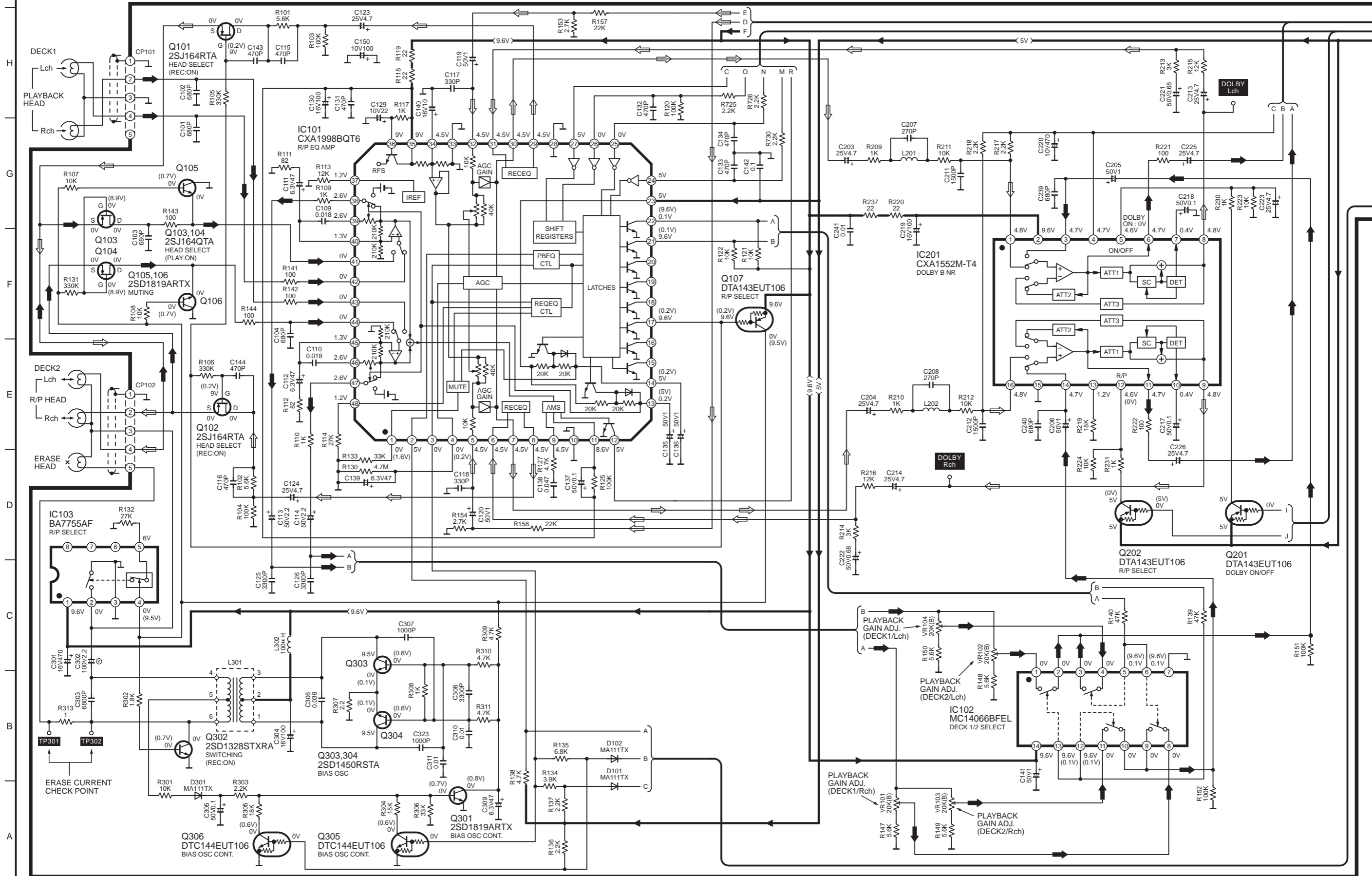

A MAIN CIRCUIT

→ : POSITIVE VOLTAGE LINE ⇨ : RECORDING SIGNAL LINE ⇩ : PLAYBACK SIGNAL LINE

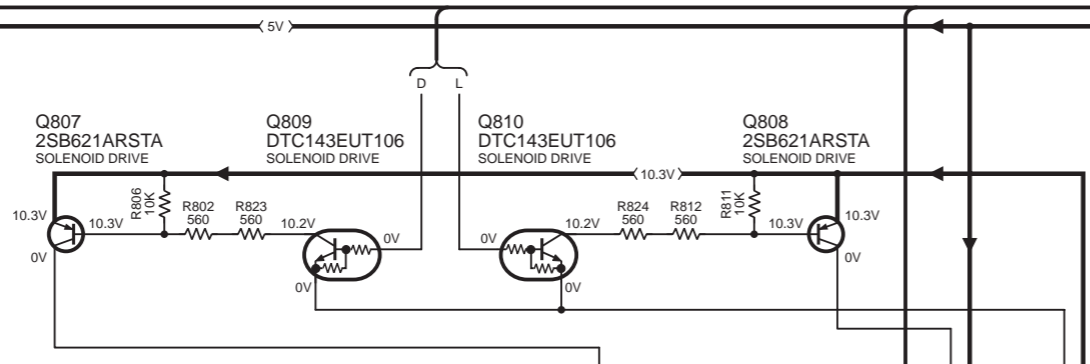

B MECHANISM CIRCUIT (DECK1)

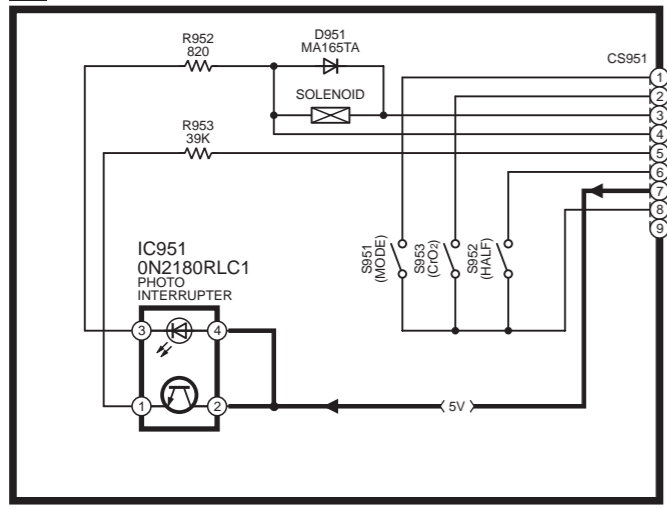

C MECHANISM CIRCUIT (DECK2)

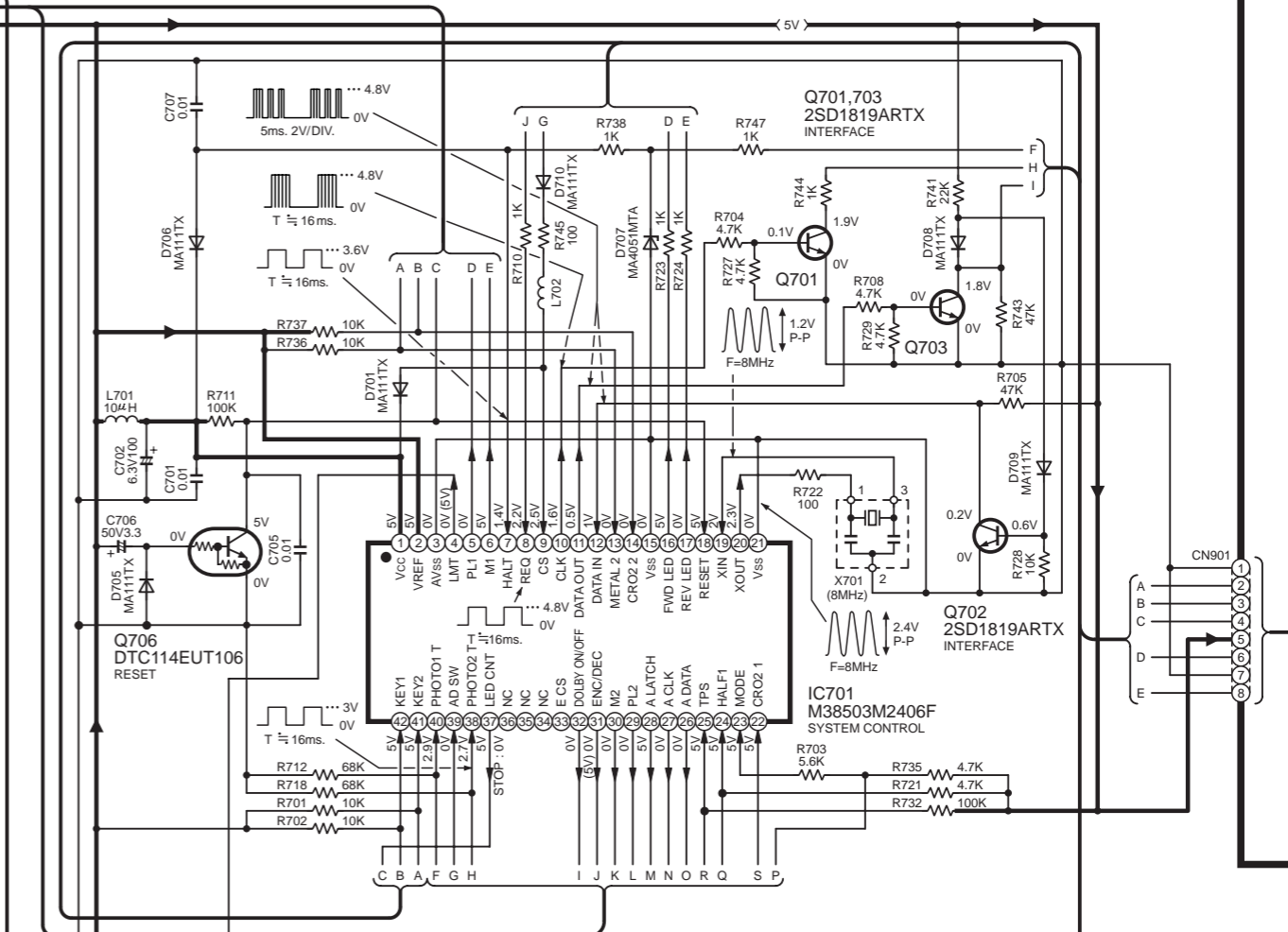
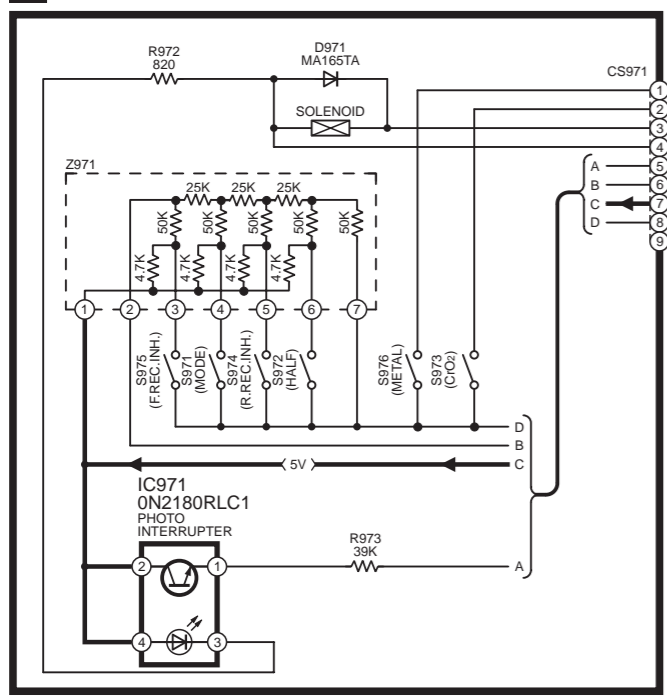

D EARTH TERMINAL CIRCUIT

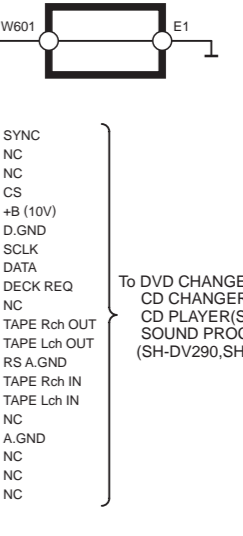

To DVD CHANGER (SL-DV290)
 CD CHANGER (SL-EH790)
 CD PLAYER (SL-EH590) &
 SOUND PROCESSOR (SH-DV290, SH-EH790, 590)

ORDER NO. AD0305100C8

Service Manual

Tuner/ Amplifier

SA-DV290EE / SA-DV290GN

Colour

(S).....Silver Type

System: SC-DV290

Because of unique interconnecting cables, when a compact requires service, send or bring in the entire system.

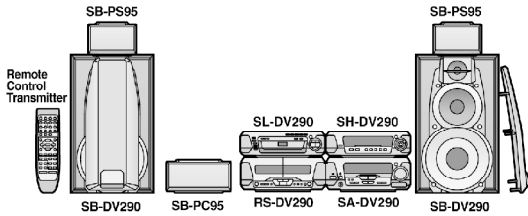

SPECIFICATIONS

Specification

■ **Amplifier section**

Power output (L/R both channel driven)

Stereo Mode

DIN	1 kHz THD 1%/6 Ω (High)	2×25 W
	100 Hz THD 1%/8 Ω (Low)	2×45 W
RMS	1 kHz THD 10%/6 Ω (High)	2×35 W
	100 Hz THD 10%/8 Ω (Low)	2×65 W

PRO LOGIC mode

DIN	FRONT	
	1 kHz THD 1%/6 Ω (High)	2×25 W
	100 Hz THD 1%/8 Ω (Low)	2×45 W
	SURROUND 1 kHz THD 1%/8 Ω	2×30 W
	CENTER 1 kHz THD 1%/8 Ω	60 W
RMS	FRONT	
	1 kHz THD 10%/6 Ω (High)	2×35 W
	100 Hz THD 10%/8 Ω (Low)	2×65 W
	SURROUND 1 kHz THD 10%/8 Ω	2×40 W
	CENTER 1 kHz THD 10%/8 Ω	80 W

PMPO	1 kHz/High 6 Ω , Low 8 Ω , CENT. 8 Ω , SURR. 8 Ω	3000 W
-------------	---	--------

Total harmonic distortion

Rated power at 1 kHz	1% (6 Ω)
Half power at 1 kHz	0.1% (6 Ω)

Load impedance

FRONT (High)	6 Ω
FRONT (Low)	8 Ω
SURROUND	8 Ω
CENTER	8 Ω

DIGITAL S. WOOFER

Center frequency	60 Hz
LEVEL (VOL -20 db)	MID +3 db MAX +6 db

■ **FM tuner section**

Frequency range	87.50—108.00 MHz (0.05 MHz steps)
Sensitivity	1.8 μ V (IHF usable)
S/N 26 db	1.5 μ V
S/N	
MONO	70 db (75 db, IHF)
Antenna terminal(s)	75 Ω (unbalanced)

■ **AM tuner section**

Frequency range	522—1629 kHz (9 kHz steps) 520—1630 (10 kHz steps)
Sensitivity (S/N 20 db)	500 μ V/m

■ **Timer section**

Clock	Quartz-lock type
Function	Play timer (1 time, daily),

Rec timer (1 time, daily)
 Sleep (120 min, 30 min intervals)
 Setting intervals (Play/Rec) 1 minute—23 hours 59 minutes
 (1 min intervals)

■ **General**

Power supply

(For (GN) area) AC 230—240V 50Hz

(For (EE) area) AC 230V 50Hz

Power consumption 230 W

Standby 0.5 W

Dimensions (W×H×D) 293×118.5×345 mm

Mass 5.3 kg

- Notes**
- 1.Design and specifications are subject to change without notice.
 - 2.Dimensions and weight are approximate.
 - 3.Total harmonic distortion is measured by the digital spectrum analyzer.

■ **System/SC-DV290**

Sound processor: SH-DV290, DVD/ Video CD/ CD
 changer: SL-DV290, Tuner/ Amplifier: SA-DV290 ,
 Cassette Deck: RS-DV290, Speakers: Front* (SB-
 DV290),Center* (SB-PC95),Surround* (SB-PS95)
 (*Madein MESA.)

⚠ WARNING

This service information is designed for experienced repair technicians only and is not designed for use by the general public. It does not contain warnings or cautions to advise non-technical individuals of potential dangers in attempting to service a product. Products powered by electricity should be serviced or repaired only by experienced professional technicians. Any attempt to service or repair the product or products dealt with in this service information by anyone else could result in serious injury or death.

Technics

1. Accessories

- AC mains lead for (EE) areas
 (RJA0019-2X).....1 pc.

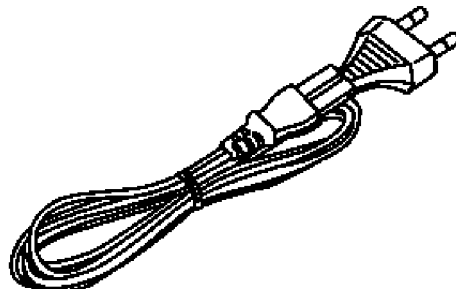

- AC mains lead for (GN) area

(RJA0035-2X).....1 pc.

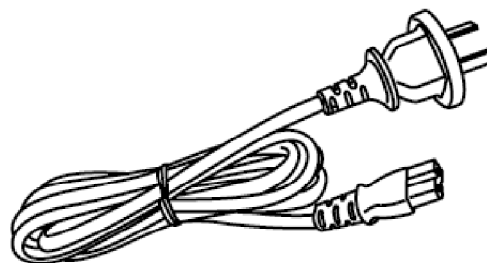

**- Remote control for (EE) area
(EUR7702290).....1 pc.**

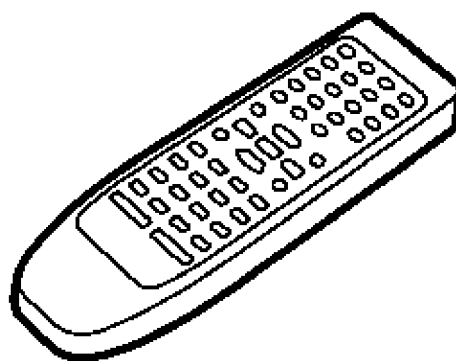

**- Remote control for (GN) area
(EUR7702300).....1 pc.**

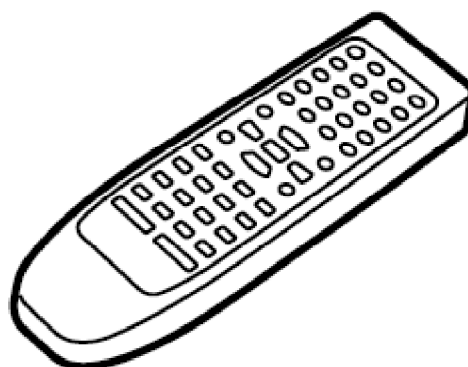

**- Remote control batteries
(R6/LR6,"AA",UM-3).....1 pc.**

Note: These are available on sales route.

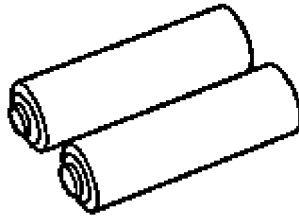

- FM indoor antenna for (EE) area
(N1EAYY000002).....1 pc.

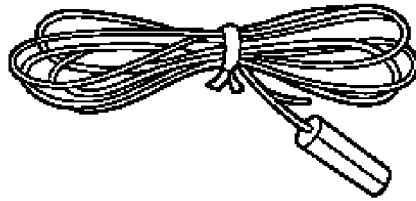

- FM indoor antenna for (GN) area
(N1EAYY000001).....1 pc.

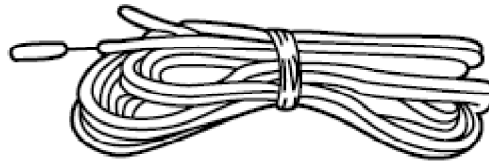

- AM loop antenna set
(N1DAEYA00008).....1 pc.

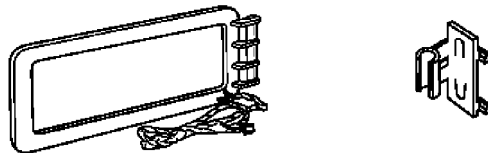

- Speaker leads
(REE1234-1).....2 pc.
(Red/Black)

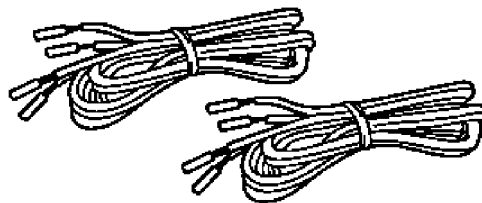

(REE1233-1).....2 pc.
(Gray/Blue)

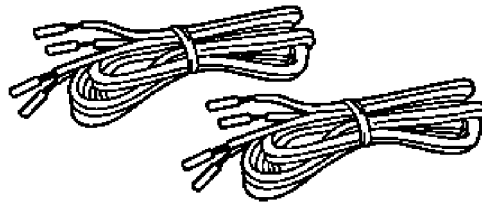

- Video cord
(K2JA2A000018).....1 pc.

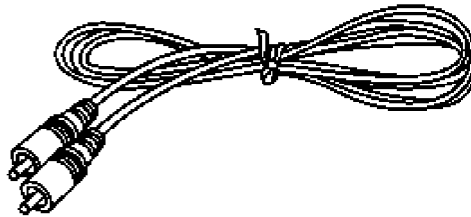

- RCAJ adaptor for (EE) area
(K1JZ24D00002).....1 pc.

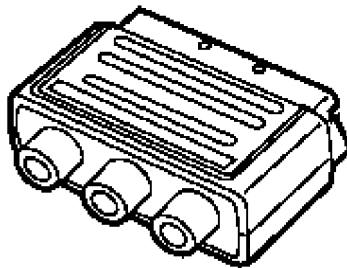

2. Before Repair and Adjustment

1. Turn off the power supply. Using a 10 Ω , 10W resistor, connect both ends of power supply capacitors (C701-704) in order to discharge the voltage.
2. Before turning the power supply on, after completion of repair, slowly apply the primary voltage by using a power supply voltage controller to make sure that the consumed current at 50 Hz in NO SIGNAL mode should be shown below with respect to supply voltage 230 V/240 V.

Areas	(EE)		(GN)	
Power supply voltage	AC 230V		AC 230-240V	
Consumed current	50 Hz	130-380 mA	50 Hz	130-380 mA

3. About the Protection Circuitry



The protection circuitry may have operated if either of the following conditions is noticed:

*No sound is heard when the power is supplied.

*Sound stops during a performance.

The functions of this circuitry is to prevent circuitry damage, for example, the positive and negative speaker connection wires are “shorted”, or if speaker systems with an impedance less than the indicated rated impedance of this unit are used.

If this occurs, follow the procedure outlined below:

1. Press the **STANDBY** /ON button, switch to **STANDBY** mode.
2. Determine the cause of the problem and correct it.
3. Press the **STANDBY** /ON button once again, supply the power.

Note:

When the protection circuitry functions, the unit will not operate unless the **STANDBY** /ON button is first switched **STANDBY** and then **ON** again.

4. Operating Instructions

5. Operation Checks and Component Replacement Procedures

- This section describes procedures for checking the operation of the major printed circuit boards and replacing the main components.
- For reassembly after operation checks or replacement, reverse the respective procedures. Special reassembly procedures are described only when required.

5.1. Checking for the AC IN P.C.B.

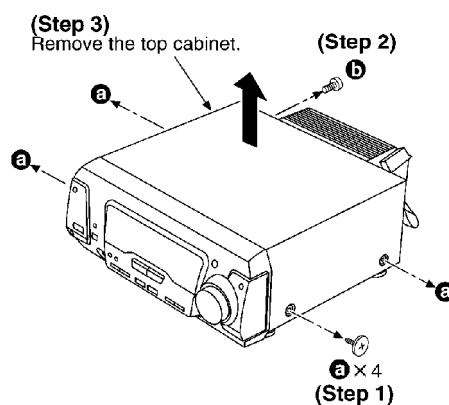

- Check the AC IN P.C.B. as shown below.

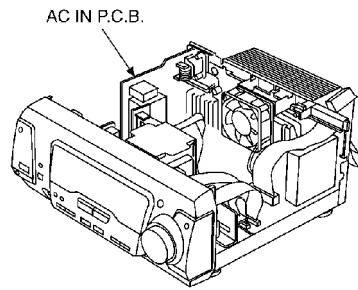

5.2. Checking for the operation P.C.B.

- Follow the (Step 1) - (Step 3) of item 5.1.

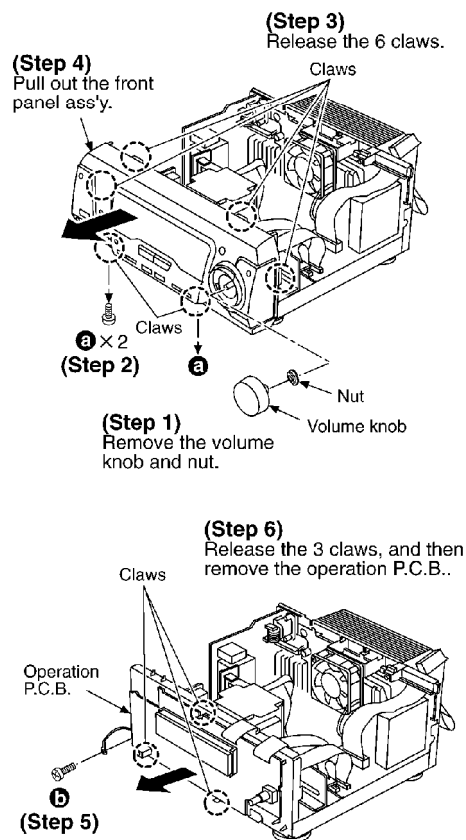

- Check the operation P.C.B. as shown below.

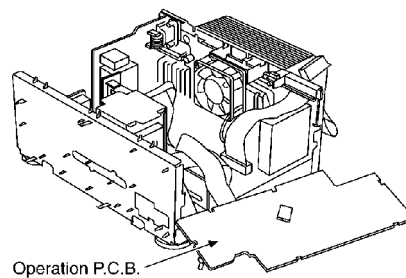

5.3. Checking for the main P.C.B.

- Follow the (Step 1) - (Step 3) of item 5.1.

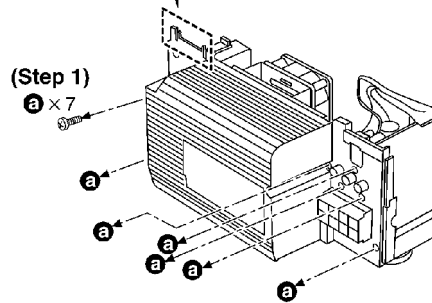
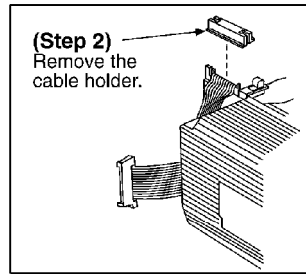

(Step 3)
Release the 2 claws, and then remove the back cover ass'y.

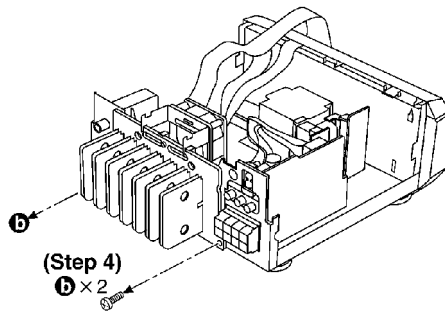
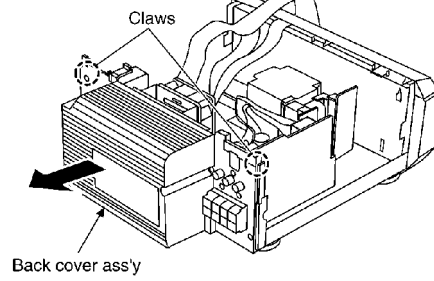

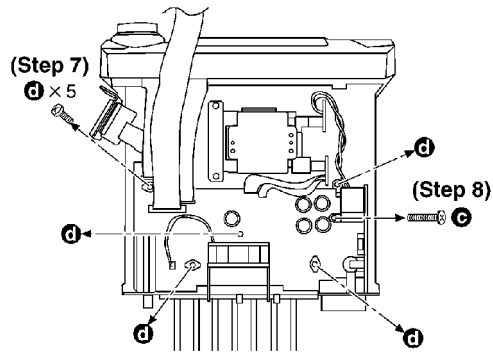
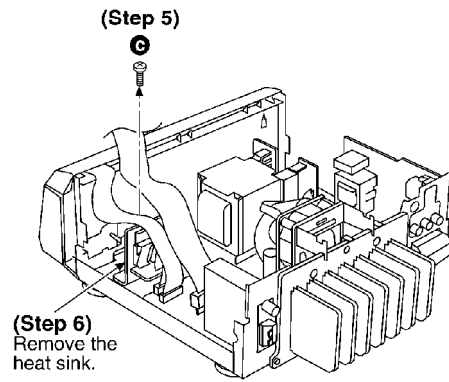

(Step 9)
Release the 2 claws, and then lift up the main P.C.B..

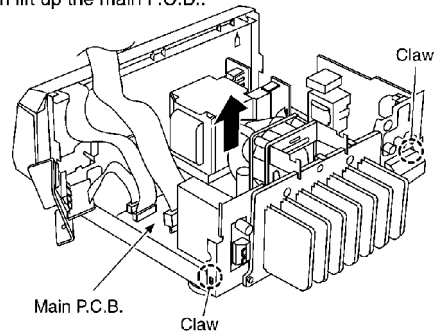

- Check the main P.C.B. as shown below.

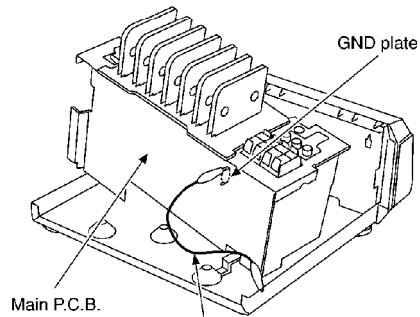

(Step 10)
Connect the lead wire.

5.4. Replacement for the regulator transistor

- Follow the (Step 1) - (Step 3) of item 5.1.

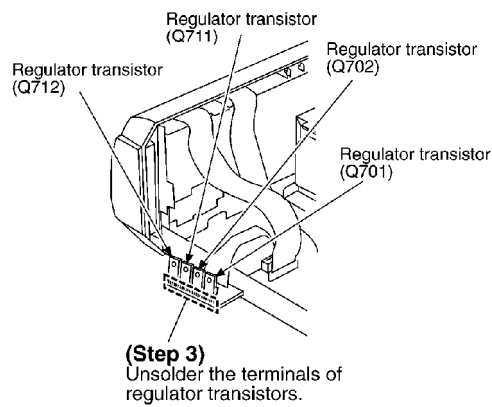
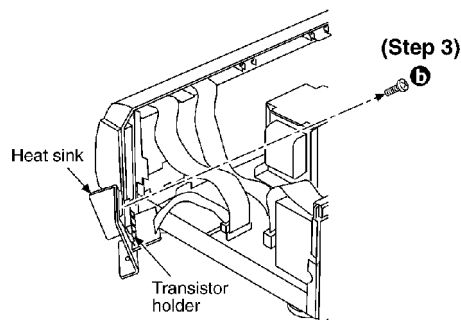
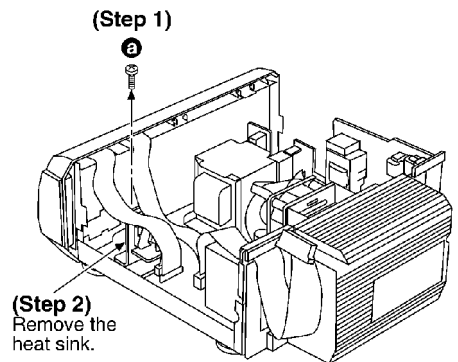

5.5. Replacement for the power IC

- Follow the (Step 1) - (Step 3) of item 5.1.

- Follow the (Step 1) - (Step 6) of item 5.2.

- Follow the (Step 1) - (Step 10) of item 5.3.

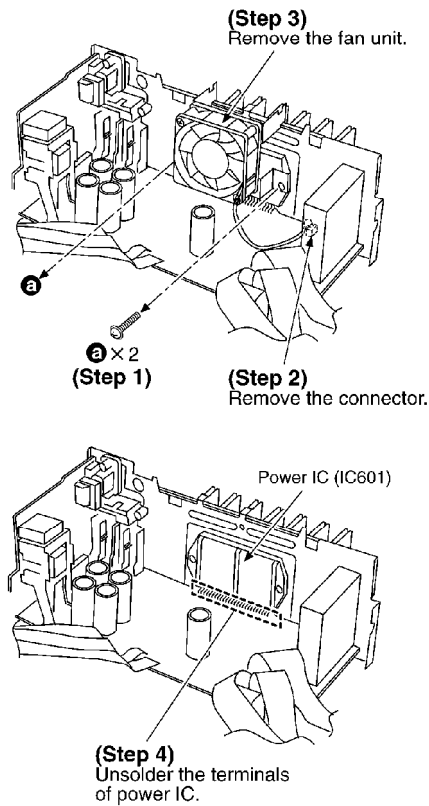

NOTE:
When mounting the power IC apply silicone compound (RFKX0002) to the rear side of power IC.

6. Self-Diagnostic Function

This unit equipped with a self-diagnostic function which, in the event of a malfunction, automatically displays a code indicating the nature of the malfunction.

Use this self-diagnostic function when servicing the unit.

6.1. To display the malfunction code

U70 DVD: Automatically displays on the

U70 DECK: tuner/amplifier when a malfunction occurs. Refer to Fig. 6-1.

F61: Automatically displays on the tuner/amplifier when a malfunction occurs. Refer to Fig. 6-1.

Fig. 6-1

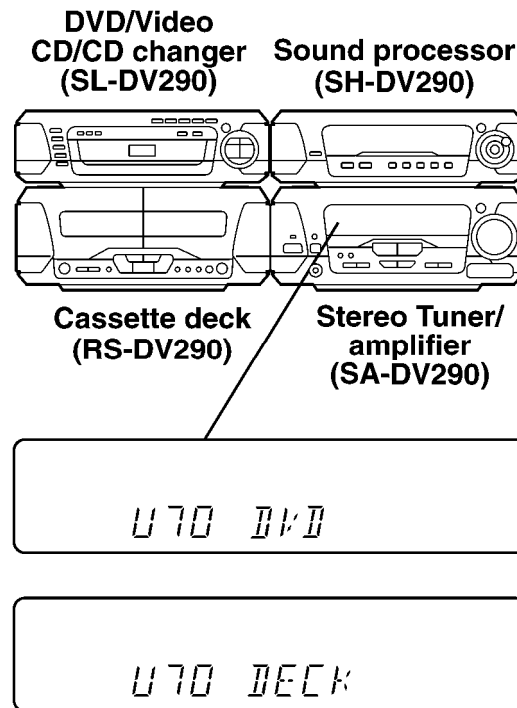

6.2. To return to the normal display

1. For U70 DVD/U70 DECK

- Press an any operation button on the tuner/amplifier.
- To re-display the code, switch the power off (POWER STANDBY button), and then switch power back on again.

2. For F61

- If F61 is displayed, the power will automatically be switched off and the standby indicator will light up.
- F61 will be displayed for 3 seconds, and then the clock will be displayed.
- To re-display the code, switch the power on. F61 will be re-displayed, and then after 3 seconds the clock will be displayed and the power will automatically switch off.

6.3. Display contents

6.3.1. U70 DVD, U70 DECK / (displayed automatically)

- Problem or condition

A bus-line communications error has occurred as a result of the flat cables being inserted incorrectly, thus preventing the system from operating.

- If U70 is displayed on the tuner/amplifier, the Cassette deck or DVD Changer cannot be operated by remote control.

- Correction Procedure

1. To check for correct insertion of the flat cables.

- Insert each connectors until you hear a click.

- Insert the flat cables at the back of the unit in the order indicated. Refer to Fig. 6-2.

Make sure the white side of the cables is on your right side. Refer to Fig. 6-3.

Fig. 6-2.

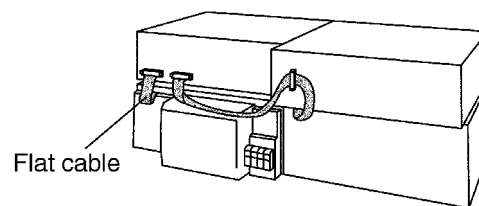
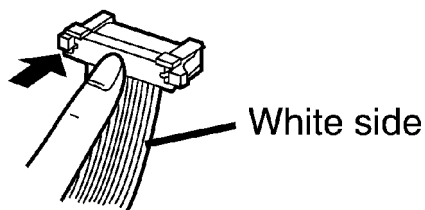

Fig. 6-3.



2. Breakage of the flat cables. (Check and replace.)

3. If the problem is not corrected by items 1 and 2 above, this indicates a faulty IC.

SA-DV290:

IC901 (C2BBFD000404)

SL-DV290:

IC401 (C2BBFD000402)

RS-DV290:

IC701 (M38503M2406F)

Check these ICs and replace.

6.3.2. F61

- Problem or condition

When the power switch is switched on, it automatically switches back off, making it impossible to switch power on.

- Correction procedure

Faulty Tuner/Amplifier (SA-DV290) output IC (IC601).

(When a DC voltage is applied to speaker terminals.)

7. To Supply Power Source

This unit SA-DV290 is designed to operate on power supplied from system connected.
For system connection, refer to Fig. 7-1.

Fig. 7-1.

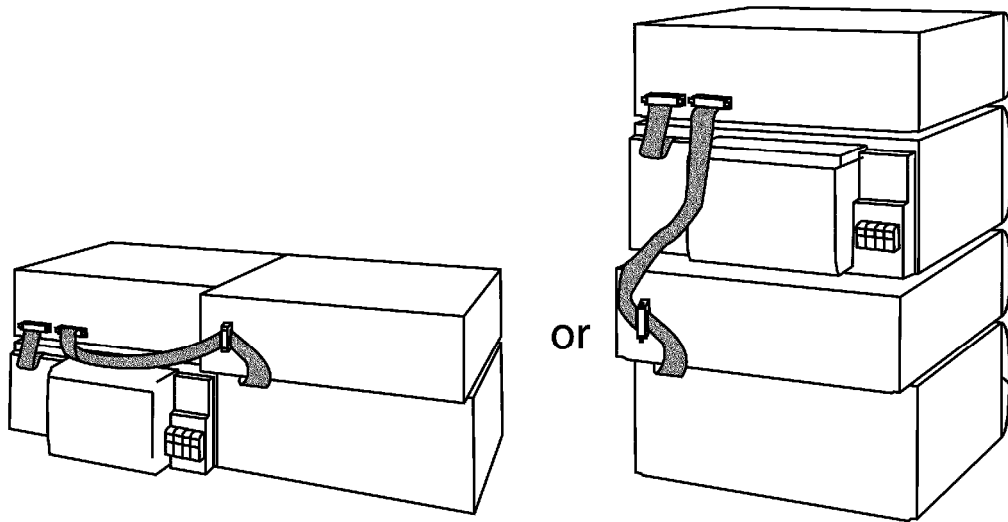

When the unit SA-DV290 has to test and service alone, use the following method to supply power source.

- 1. Short the section between W902A Pin 3 and C740 (-) (GND). (Refer to Fig. 7-2.)**
- 2. Connect this unit to an AC power supply cord. (This unit come to stand-by mode.)**
- 3. Turn the unit ON.**

Fig. 7-2.

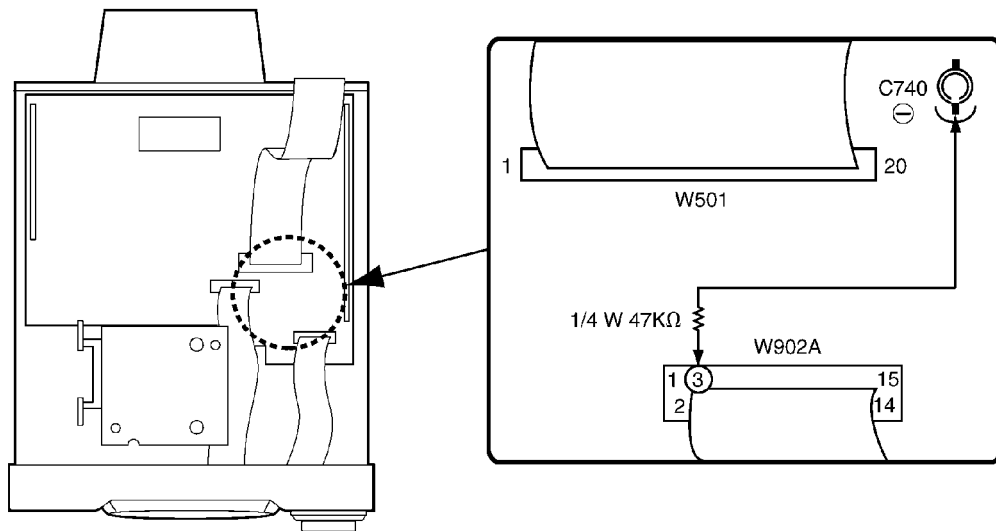

Notes:

Use only this method when checking the voltage etc..

In case of checking operations, use the system connections to supply power source.

8. Schematic Diagram Notes





8.1. Type Illustration of IC's, Transistors and Diodes

8.2. Schematic Diagram Notes

- This schematic diagram may be modified at any time with the development of new technology.

Notes:

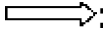
- S901: Power Standby/on (⏻/⏻) switch.
- S902: Clock/timer (CLOCK/TIMER) switch.
- S903: Demo (-DEMO) switch.
- S904: Play timer/record timer (⏪PLAY/⏪REC) switch.
- S905: FM mode (FM AUTO/MONO) switch.
- S906: Tuning mode (TUNING MODE) switch.
- S907: Set (SET) switch.
- S908: Source input (INPUT SELECTOR) switch.
- S909: Echo (ECHO) switch. For [GN] area.
- S910: Tuning (TUNING, √) switch. For [EE] area.
- S910: Tuning (TUNING, √, b) switch. For [GN] area.
- S911: Tuning (TUNING, ^) switch. For [EE] area.
- S911: Tuning (TUNING, ^, #) switch. For [GN] area.
- S912: Tuner/band (TUNER/BAND) switch.

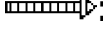
- S913: Digital super woofer (DIGITAL S. WOOFER) switch.
- S914, 915: RDS display mode (RDS, PS-DISP, MODE-PTY) switches.
For [EE] area.
S914, 915: KARAOKE, Voice mute (KARAOKE, V.MUTE) switch.
For [GN] area.
- S916: Key control (KEY CON) switch. For [GN] area.
- S917: MIC effect (MIC EFFECT, LOUNGE) switch. For [GN] area.
- S918: MIC effect (MIC EFFECT, CHORUS) switch. For [GN] area.
- VR901: Main volume V.R..
- Indicated voltage values are the standard values for the unit measured by the DC electronic circuit tester (high-impedance) with the chassis taken as standard. Therefore, there may exist some errors in the voltage values, depending on the internal impedance of the DC circuit tester.
No mark: Power ON
- Important safety notice:
Components identified by  mark have special characteristics important for safety.
Furthermore, special parts which have purposes of fire-retardant (resistors), high-quality sound (capacitors), low-noise (resistors), etc. are used.
When replacing any of components, be sure to use only manufacture's specified parts shown in the parts list.
- Caution!**
- Secondary trouble can be prevented by taking care during repair.
- IC and LSI are sensitive to static electricity.
- Cover the parts boxes made of plastics with aluminum foil.
- Ground the soldering iron.
- Put a conductive mat on the work table.
- Do not touch the legs of IC or LSI with the fingers directly.
- Voltage and signal lines
 - : Positive voltage line
 - : Negative voltage line
 - : Audio signal line
 - : Tuner signal line
 - : MIC signal line

9. Schematic Diagram

10. Printed Circuit Board Diagram

11. Block Diagram

12. Wiring Connection Diagram

13. Terminal Function of ICs

13.1. IC901 (C2BBFD000404): System Control/FL Drive

Pin No.	Terminal Name	I/O	Function
1	CHECK	I	Clock check signal input
2	LC72 DO	O	PLL data signal output for tuner unit (Z101)
3	LC72 CE	O	Chip enable signal output for tuner unit (Z101)
4	LC72 DI/ST	I	IF count data/stereo detect signal input from tuner unit (Z101)
5	LC72 CK	O	Clock signal output for tuner unit (Z101)
6	ST/AV.6CH	O	Signal select output
7	NC	—	Not used, open
8			
9	SEL TUNER	—	Not used, open
10	SEL/TUNER	—	Not used, connected to GND
11	AC IN	I	Power failure detect signal input
12	RESET	I	Reset signal input
13	X IN	I	Oscillator connected terminal (32.7kHz)
14	X OUT	O	
15	Vss	—	GND terminal
16	XC IN	I	Oscillator connected terminal (6 MHz)
17	XC OUT	O	
18	VDD 1	I	Power supply terminal
19	KEY TU	I	Operation key signal input
20	KEY KARAOKE	I	Operation key signal input

Pin No.	Terminal Name	I/O	Function
21	SH REQ	O	Request signal output to Sound Processor
22	NC(GND)	—	Not used, connected to GND
23	VR JOGB	I	Volume control signal input
24	VR JOGA		
25	MIC DET	I	Microphone connecting detect signal input (Not used, connected to V _{DD})
26	HP SW	I	Headphone connecting detect signal input
27	RDS CLK	I	RDS clock signal input
28	RDS DATA	I	RDS data signal input
29	REMOCON	I	Remote control signal input
30-37	8G-1G	O	Grid signal output
38-45	P1-P8	O	Segment signal output
46	V _{DD} 3	I	Power supply terminal
47-50	P9-P12	O	Segment signal output
51	-VP	I	Power supply terminal (Negative)
52-71	P13-P32	O	Segment signal output
72	V _{DD} 4	I	Power supply terminal
73-78	P33-P38	O	Segment signal output
79	REGIN0	—	Not used, connected to GND
80	REGIN1		
81	STANDBY	O	LED (STANDBY) drive signal output
82	TIMER	O	LED (TIMER) drive signal output
83	S.W.LED	O	LED (DIGITAL S.WOOFER) drive signal output
84	LOUNGE	—	LED (LOUNGE) drive signal output (Not used, connected to GND)

Pin No.	Terminal Name	I/O	Function
85	CHORUS	—	LED (CHORUS) drive signal output (Not used, connected to VDD)
86	MUTE	O	Muting signal output
87	NC	—	Not used, open
88	POWER	O	Power control signal output
89	Vss 2	—	GND terminal
90	VDD 2	I	Power supply terminal
91	MUTE2	O	Muting signal output
92	NC	—	Not used, open
93	MUTE3	O	Muting signal output
94	SH CS	I/O	Chip select signal for Sound Processor
95	SH DO	O	Serial communication signal to Sound Processor (Data signal output)
96	SH DI	I	Serial communication signal to Sound Processor (Data signal input)
97	SH CK	I	Serial communication signal to Sound Processor (Clock signal input)
98	E DET	I	Unusual condition detect signal input
99	CR TIMER	—	Not used, open
100	SD	I	Station detector signal input from tuner unit (Z101)

14. Replacement Parts List

Notes:

* Important safety notice:

Components identified by  mark have special characteristics important for safety. / Furthermore, special parts which have purposes of fire-retardant (resistors), high-quality sound (capacitors), low-noise (resistors), etc. are used. /

When replacing any of components, be sure to use only manufacture's specified parts shown in the parts list.

* The parenthesized indications in the Remarks columns specify the areas. / Parts without these indications can be used for all areas.

*** Remote Control Ass'y: Supply period for three years from terminal of production.**

*** Capacity values are in microfarads (uF) unless specified otherwise, P=Pico-farads(pF), F=Farads (F)**

*** Resistance values are in ohms, unless specified otherwise, 1K= 1,000 (OHM), 1M=1,000K (OHM)**

***The markings (RTL) indicate that the retention time is limited for these items. After the discontinuation of these assemblies in production, it will no longer be available.**

***All parts are supplied by SPC.**

Ref. No.	Part No.	Part Name & Description	Pcs	Remarks
1	RGN2398-K	NAME PLATE	1	(EE)
1	RGN2399-K	NAME PLATE	1	(GN)
2	RMQ1018	GASKET	1	
3	REM0115	FAN UNIT	1	
4	REX0967	SYSTEM CONNECT.ASS'Y(20P)	1	
5	J0KD00000028	FERRITE CORE	1	
6	RGW0386-S	KNOB,VOLUME	1	
7	RHN90001	NUT	1	
8	RKA0106-N	FOOT RING	4	
9	RKF0606AD-K1	BACK COVER	1	(EE)
9	RKF0606AE-K1	BACK COVER	1	(GN)
10	RKW0581-1V	FL WINDOW	1	
11	RMF0284	CUSHION	1	(GN)
12	RMN0427A	CABLE HOLDER	1	
13	RYP1168-S	FRONT PANEL ASS'Y	1	(EE)
13	RYP1168A-S	FRONT PANEL ASS'Y	1	(GN)
13-1	RGB0025-A	TECHNICS BADGE	1	
13-2	RGU1748-Q	BUTTON,MIC EFFECT	1	(GN)
14	SHG1654	RUBBER	4	
15	XTB3+10JFZ	SCREW	12	
16	XTB3+20JFZ	SCREW	1	
17	XTB3+8JFZ	SCREW	12	
18	XTW3+15T	SCREW	2	
19	XTB3+12FFZ	SCREW	1	
20	XTBS3+8JFZ1	SCREW	2	
21	RHD30007-1S	SCREW	4	
22	RKM0395G-2S	TOP CABINET	1	
23	XTBS3+10JFZ1	SCREW	1	
24	RAN0005EM-2	TUNER PACK(Z101)	1	(EE)
24	ENG06502Q	TUNER PACK(Z101)	1	(GN)
25	RMN0526	FL HOLDER	1	
26	RMN0744	FAN SUPPORTER	1	
27	RMN0745	FAN SUPPORTER	1	
28	REZ1300	WIRE ASS'Y	1	
29	REZ1205	WIRE ASS'Y	1	(GN)
30	RGW0178-1S	KNOB,MIC VOL	1	(GN)
31	XTB3+8JFZ	SCREW	1	(GN)

Ref. No.	Part No.	Part Name & Description	Pcs	Remarks
A1	EUR7702290	REMOTE CONTROL	1	(EE)
A1	EUR7702300	REMOTE CONTROL	1	(GN)
A1-1	UR64EC2337E	BATTERY COVER	1	
A2	K2JA2A000018	VIDEO CORD	1	
A3	REE1233-1	SPEAKER LEADS(GRAY/BLUE)	1	
A4	REE1234-1	SPEAKER LEADS(RED/BLACK)	1	
A5	RJA0019-2X	AC MAINS LEAD	1	(EE) ⚠
A5	RJA0035-2X	AC MAINS LEAD	1	(GN) ⚠
A7	RQCA0801	QUICK SET-UP GUIDE	1	
A8	RQT6895-R	O/I BOOK	1	(EE) Russian
A9	RQT6894-B	O/I BOOK	1	English
A10	N1EAYY000002	FM INDOOR ANTENNA	1	(EE)
A10	N1EAYY000001	FM INDOOR ANTENNA	1	(GN)
A11	N1DAEYA00008	AM LOOP ANTENNA	1	
A13	K1JZ24D00002	RCAJ ADAPTOR	1	(EE)
C151	ECA1CAK100XB	16V 10U	1	(EE)
C152	ECBT1H331KB3	50V 330P	1	(EE)
C153	ECBT1H102KB3	50V 1000P	1	(EE)
C154	ECBT1H561KB3	50V 560P	1	(EE)
C155	ECBT1H102KB3	50V 1000P	1	(EE)
C156,57	ECBT1H470J3	50V 47P	2	(EE)
C158,59	ECEA0JKS470	6.3V 47U	2	(EE)
C160	ECBT1H102KB3	50V 1000P	1	(EE)
C201,02	F1D1H1040002	50V 0.1U	2	
C371	ECA0JAK101XB	6.3V 100U	1	
C395,96	F1D1H473A012	50V 0.047U	2	
C401	ECBT1H223KB5	50V 0.022U	1	F1D1H223A012 (GN)
C403	ECBT1C472KR5	16V 4700P	1	F1D1C472A010 (GN)
C404	RCE1HKA3R3BG	50V 3.3U	1	F2A1H3R3A015 (GN)
C405	ECBT1H102KB3	50V 1000P	1	(GN)
C406	ECEA1EKS4R7	25V 4.7U	1	(GN)
C407	ECBT1H103KB5	50V 0.01U	1	F1E1H1030001 (GN)
C408	ECBT1H223KB5	50V 0.022U	1	F1D1H223A012 (GN)
C409	ECEA1HKS010	50V 1U	1	(GN)
C410	F2A1C100A034	16V 10U	1	(GN)
C411	ECBA1H101KB3	50V 100P	1	(GN)
C412	ECBT1H102KB3	50V 1000P	1	(GN)
C413	ECEA1HKS010	50V 1U	1	(GN)
C414	ECA1CAM471XB	16V 470U	1	(GN)
C415	ECEA1HKS010	50V 1U	1	(GN)
C416	ECA1CAK100XB	16V 10U	1	(GN)
C417	ECBT1H223KB5	50V 0.022U	1	F1D1H223A012 (GN)
C421	F1D1H1040002	50V 0.1U	1	(GN)
C509,10	ECBT1H103KB5	50V 0.01U	2	F1E1H1030001
C550	ECBT1H103KB5	50V 0.01U	1	F1E1H1030001
C551	ECA1HAK2R2XB	50V 2.2U	1	
C552	ECBT1H103KB5	50V 0.01U	1	F1E1H1030001
C554	ECA1CAM221XB	16V 220U	1	
C555	ECEA1HSN010	50V 1U	1	
C556	ECEA1CKN100	16V 10U	1	
C559	ECBT1H103KB5	50V 0.01U	1	F1E1H1030001

Ref. No.	Part No.	Part Name & Description	Pcs	Remarks
C601,02	ECA1CAK100XB	16V 10U	2	
C603,04	ECBT1H471KB3	50V 470P	2	
C605,06	ECBT1H102KB3	50V 1000P	2	
C607,08	ECBT1H471KB3	50V 470P	2	
C609,10	ECBT1H560J3	50V 56P	2	
C611	F1D1H390A006	50V 39P	1	
C612	ECBT1H150JC3	50V 15P	1	
C613,14	ECBT1H470J3	50V 47P	2	
C616	ECEA1HKNR47B	50V 0.47U	1	
C617,18	ECKR2H103ZU	500V 0.01U	2	
C619-21	F1D1H1040002	50V 0.1U	3	
C622	F2A1A1010020	10V 100U	1	
C624-31	F1D1H1040002	50V 0.1U	8	
C632	F1D1H473A012	50V 0.047U	1	
C633,34	F1D1H1040002	50V 0.1U	2	
C635-37	F1D1H473A012	50V 0.047U	3	
C639-44	ECBT1H102KB3	50V 1000P	6	
C645,46	F1D1H473A012	50V 0.047U	2	
C647-50	ECBT1H102KB3	50V 1000P	4	
C651	F1D1H473A012	50V 0.047U	1	
C652	ECBT1H102KB3	50V 1000P	1	
C655,56	ECA1CAK100XB	16V 10U	2	
C659,60	ECA1CAK100XB	16V 10U	2	
C664	ECA1CAK100XB	16V 10U	1	
C701-04	ECA1VM472E	35V 4700U	4	
C705	ECBT1H103KB5	50V 0.01U	1	F1E1H1030001
C706	RCE1VKA100BG	35V 10U	1	F2A1V1000011
C707,08	F1D1H473A012	50V 0.047U	2	
C709	ECQV1H104JM3	50V 0.1U	1	
C710	F1D1H473A012	50V 0.047U	1	
C714	ECBT1H102KB3	50V 1000P	1	
C715	ECA1EAM682XE	25V 6800U	1	
C717	ECA1CAK330XB	16V 33U	1	
C718	ECA1EAM101XB	25V 100U	1	
C719,20	F1D1H473A012	50V 0.047U	2	
C721	F2A1A1010020	10V 100U	1	
C722	ECA1EAM101XB	25V 100U	1	
C723,24	F1D1H473A012	50V 0.047U	2	
C725	ECA1CAK470XB	16V 47U	1	
C731	ECBT1H102KB3	50V 1000P	1	
C732	ECBT1H223KB5	50V 0.022U	1	F1D1H223A012
C733	F1D1H473A012	50V 0.047U	1	
C734	RCE1HKA3R3BG	50V 3.3U	1	F2A1H3R3A015
C735	F1D1H473A012	50V 0.047U	1	
C737	ECA1HAM101XB	50V 100U	1	
C740	ECA1CAK100XB	16V 10U	1	
C741	ECQE1104KF3	100V 0.1U	1	
C753	F1B1H1030001	50V 0.01U	1	
C754	ECBT1H103KB5	50V 0.01U	1	F1E1H1030001
C755	ECA1CAM102X	16V 1000U	1	
C758	ECBT1H103KB5	50V 0.01U	1	F1E1H1030001
C759	RCE1AKA470BG	10V 47U	1	F2A1A470A011
C761	ECQE1104KF3	100V 0.1U	1	
C791	ECKWRS102MBC	250V 1000P	1	



Ref. No.	Part No.	Part Name & Description	Pcs	Remarks
C901	EEAFC0J101B	6.3V 100U	1	
C902	F2A1A102A018	10V 1000U	1	
C903,04	ECBT1H103KB5	50V 0.01U	2	F1E1H1030001
C905	ECBT1H102KB3	50V 1000P	1	
C907,08	ECBT1H471KB3	50V 470P	2	
C909	ECBT1H102KB3	50V 1000P	1	
C910	ECBT1H200JC5	50V 20P	1	F1D1H200A015
C911	F1D1H180A006	50V 18P	1	
C912	F1D1H1040002	50V 0.1U	1	
C914	ECA1HAK2R2XB	50V 2.2U	1	
C915	ECBT1H103KB5	50V 0.01U	1	F1E1H1030001
C916	EEAFC0J101B	6.3V 100U	1	
C917	ECBT1H103KB5	50V 0.01U	1	F1E1H1030001
C918	ECA0JAK101XB	6.3V 100U	1	
C919,20	ECA1EAK220XB	25V 22U	2	
C921	ECBT1H102KB3	50V 1000P	1	
C922	ECA1VAK330XB	35V 33U	1	
C923,24	F1D1H1040002	50V 0.1U	2	
C925,26	ECBT1H102KB3	50V 1000P	2	
C927,28	ECA1EAK220XB	25V 22U	2	
C931	ECEA1CKN100	16V 10U	1	
CN601	RJU057W012	CONNECTOR(12P)	1	K1KB12B00033
CN602	RJU057W008	CONNECTOR(8P)	1	K1KB08B00034
CN701-13	RJS1A1101T1	CONNECTOR(1P)	13	
CN781	RJS10T5ZA	CONNECTOT(10P)	1	K1MP10A00007
CN904	RJS4T5ZA	CONNECTOR(4P)	1	K1MP04A00007 (GN)
CP101	K1KA11A00093	CONNECTOR(11P)	1	
CP601	RJT057W012-1	CONNECTOR(12P)	1	K1KA12A00160
CP602	RJT057W008-1	CONNECTOR(8P)	1	K1KA08A00187
D151	MA4051M	DIODE	1	MAZ40510M (EE)
D201	MAZ40560MF	DIODE	1	
D306	SELS5223C	LED	1	B3AAA0000486
D500	MA165TA5	DIODE	1	MA2C16500E
D551,52	MA165TA5	DIODE	2	MA2C16500E
D553	MA700	DIODE	1	MA2C700
D554	MA165TA5	DIODE	1	MA2C16500E
D555	MA4100M	DIODE	1	MAZ41000MF
D558	MA165TA5	DIODE	1	MA2C16500E
D581-83	B0AAMM000009	DIODE	3	
D601,02	SB360L6508	DIODE	2	B0JAPG000014
D607	1SS291TA	DIODE	1	
D611	MA4051M	DIODE	1	MAZ40510M
D657-59	MA165TA5	DIODE	3	MA2C16500E
D701-04	1N5402BF	DIODE	4	
D705	B0AAMM000009	DIODE	1	
D711	B0AAMM000009	DIODE	1	
D718	B0JANG000008	DIODE	1	
D720	B0JANG000008	DIODE	1	
D721	MA4300M	DIODE	1	MAZ43000M
D723	MA4150-M	DIODE	1	MAZ41500M
D725	MA4082LTA	DIODE	1	MAZ40820LF

Ref. No.	Part No.	Part Name & Description	Pcs	Remarks
D730	MA4091H	DIODE	1	MAZ40910H
D737	MA4082LTA	DIODE	1	MAZ40820LF
D738-40	MA165TA5	DIODE	3	MA2C16500E
D741-44	B0AAMM000009	DIODE	4	
D745	MA4051M	DIODE	1	MAZ40510M
D746	B0AAMM000009	DIODE	1	
D747	MA4068L	DIODE	1	MAZ40680L
D751,52	1N5402BF	DIODE	2	
D753-55	B0AAMM000009	DIODE	3	
D756,57	MA700	DIODE	2	MA2C700
D758	MA165TA5	DIODE	1	MA2C16500E
D761	B0AAMM000009	DIODE	1	
D901,02	1SS291TA	DIODE	2	
D904	MA165TA5	DIODE	1	MA2C16500E
D905	1SS291TA	DIODE	1	
D906,07	MA165TA5	DIODE	2	MA2C16500E
D931	MA165TA5	DIODE	1	MA2C16500E
D933	MA165TA5	DIODE	1	MA2C16500E (EE)
D935	MA165TA5	DIODE	1	MA2C16500E (GN)
D951	LNJ301MPUJAD	LED	1	
D952,53	LNJ301MPUJAD	LED	2	(GN)
D954	SELS5923C	LED	1	B3ADA0000083
D961	MA4075M	DIODE	1	MAZ40750M
D973	MA4030M	DIODE	1	MAZ40300M
D974	MA165TA5	DIODE	1	MA2C16500E
F1	K5D202BL0001	FUSE	1	
FL901	A2BB00000115	FL DISPLAY TUBE	1	
FP791,92	K5G502AA0002	FUSE PROTECTOR	2	
IC151	C1BB00000527	IC	1	(EE)
IC201	C0JBAR000292	IC	1	
IC401	C1BA00000152	IC	1	(GN)
IC601	RSN311W64B	IC	1	
IC901	C2BBFD000404	IC	1	
JK551	K1KA02A00008	CONNECTOR(2P)	1	
JK601,02	K4BC04B00028	JACK,SPEAKERS	2	
JK603	K2HA103B0015	JACK,SPEAKERS	1	
JK701	K2AA2B000002	JACK,AC INLET	1	
JK901,02	RJJ65MA01	JACK,MIC	2	K2HB102J0032 (GN)
JK903	RJJ37TN02-C	JACK,HEADPHONES	1	K2HC103A0009
L151,52	ELEXT101KA9	COIL	2	(EE)
L153	G0C1R0JA0019	COIL	1	(EE)
L401	RLQA3R3JT1-Y	COIL	1	G0C3R3JA0019 (GN)
L601-06	RLQYR73MW1-0	COIL	6	G0ZZ00001606
L701	ELF15N035AN	COIL	1	
L901	G0C100JA0019	COIL	1	
L902	G0C1R0JA0019	COIL	1	





Ref. No.	Part No.	Part Name & Description	Pcs	Remarks
P1	RPG4396	PACKING CASE(SA)	1	
P1	RPG4397	PACKING CASE(RS)	1	
P1	RPG4398	PACKING CASE(SH)	1	
P1	RPG4399	PACKING CASE(SL)	1	
P2	RPN1194	POLYFOAM(SA)	1	
P2	RPN1195-2	POLYFOAM(RS)	1	
P2	RPN1196	POLYFOAM(SH)	1	
P2	RPN1197	POLYFOAM(SL)	1	
P3	SPP740-1	PROTECTION COVER	4	
P4	RPF0139-1	PROTECTION BAG(ACCESS.)	1	
P5	RPG6349	PACKING CASE(SYSTEM)	1	(EE)
P5	RPG6350	PACKING CASE(SYSTEM)	1	(GN)
P6	RPQ0951	PAD	1	
PCB1	REP3337K-M	MAIN P.C.B. ASS'Y	1	[RTL](EE)
PCB1	REP3337L-M	MAIN P.C.B. ASS'Y	1	[RTL](GN)
PCB2	REP3338A-S	SUB P.C.B. ASS'Y	1	[RTL](EE)
PCB2	REP3338B-S	SUB P.C.B. ASS'Y	1	[RTL](GN)
Q401	2SC5398RSTA	TRANSISTOR	1	B1AACF000059 (GN)
Q503	2SC5398RSTA	TRANSISTOR	1	B1AACF000059
Q551	2SA1995RSTA	TRANSISTOR	1	B1ACDF000006
Q553	B1AAGC000006	TRANSISTOR	1	
Q554	2SA1995RSTA	TRANSISTOR	1	B1ACDF000006
Q555	B1AAGC000006	TRANSISTOR	1	
Q556	2SC5398RSTA	TRANSISTOR	1	B1AACF000059
Q557	2SA1995RSTA	TRANSISTOR	1	B1ACDF000006
Q601,02	2SC5398RSTA	TRANSISTOR	2	B1AACF000059
Q605-10	B1AAGC000006	TRANSISTOR	6	
Q612	UN411FTA	TRANSISTOR	1	UNR411F00A
Q701	2SD2374PQAU	TRANSISTOR	1	2SD23740J1AU
Q702	2SB1548PQAU	TRANSISTOR	1	2SB15480J1AU
Q703,04	2SD2137PQTA	TRANSISTOR	2	2SD21370PA
Q705	2SA1995RSTA	TRANSISTOR	1	B1ACDF000006
Q707	2SB14170JA	TRANSISTOR	1	
Q708	UN4211	TRANSISTOR	1	UNR4211
Q709	B1AAGC000006	TRANSISTOR	1	
Q711,12	2SB1548PQAU	TRANSISTOR	2	2SB15480J1AU
Q723	2SC3940AQSTA	TRANSISTOR	1	2SC3940ARA
Q725	2SC5398RSTA	TRANSISTOR	1	B1AACF000059
Q726	2SC3940AQSTA	TRANSISTOR	1	2SC3940ARA
Q791	B1AAGC000006	TRANSISTOR	1	
Q901	UN4212	TRANSISTOR	1	UNR4212
Q902	UN411FTA	TRANSISTOR	1	UNR411F00A
R151,52	ERDS2FJ102	1/4W 1K	2	(EE)
R153,54	ERDS2FJ104	1/4W 100K	2	(EE)
R155	ERDS2FJ121	1/4W 120	1	(EE)
R157,58	ERDS2FJ102	1/4W 1K	2	(EE)
R202-05	ERDS2FJ104	1/4W 100K	4	
R211	ERDS2FJ271	1/4W 270	1	
R229,30	ERDS2FJ102	1/4W 1K	2	
R401,02	ERDS2FJ681	1/4W 680	2	(GN)
R403	ERDS2FJ223	1/4W 22K	1	(GN)

Ref. No.	Part No.	Part Name & Description	Pcs	Remarks
R404	ERDS2FJ471	1/4W 470	1	(GN)
R405	ERDS2FJ472	1/4W 4.7K	1	(GN)
R406	ERDS2FJ474	1/4W 470K	1	(GN)
R407	ERDS2FJ472	1/4W 4.7K	1	(GN)
R409	ERDS2FJ472	1/4W 4.7K	1	(GN)
R410	ERDS2FJ222	1/4W 2.2K	1	(GN)
R411	ERDS2FJ331	1/4W 330	1	(GN)
R412	ERDS2TJ105	1/4W 1M	1	(GN)
R415	ERDS2FJ471	1/4W 470	1	(GN)
R416	ERDS2FJ331	1/4W 330	1	(GN)
R421	ERDS2FJ223	1/4W 22K	1	(GN)
R509-12	ERDS2FJ470	1/4W 47	4	
R544	ERDS2FJ103	1/4W 10K	1	
R546,47	ERDS2TJ183	1/4W 18K	2	
R551	ERDS2TJ183	1/4W 18K	1	
R552	ERDS2FJ473	1/4W 47K	1	
R555	ERDS2FJ223	1/4W 22K	1	
R556	ERDS2FJ104	1/4W 100K	1	
R557	ERDS2FJ103	1/4W 10K	1	
R558	ERDS2FJ222	1/4W 2.2K	1	
R559	ERDS2FJ472	1/4W 4.7K	1	
R560,61	ERDS2FJ104	1/4W 100K	2	
R563,64	ERDS2TJ272T	1/4W 2.7K	2	
R566	ERDS2FJ683	1/4W 68K	1	
R567	ERG1SJ220	1W 22	1	
R568	ERDS2FJ101	1/4W 100	1	
R569	ERDS2FJ103	1/4W 10K	1	
R570	ERDS2TJ225	1/4W 2.2M	1	
R572	ERDS2FJ153	1/4W 15K	1	
R591	ERDS2FJ472	1/4W 4.7K	1	
R597,98	ERDS2FJ222	1/4W 2.2K	2	
R601-04	ERDS2FJ332	1/4W 3.3K	4	
R605,06	ERDS2FJ472	1/4W 4.7K	2	
R607-09	ERDS2FJ563	1/4W 56K	3	
R610	ERDS2FJ154	1/4W 150K	1	
R611,12	ERDS2FJ563	1/4W 56K	2	
R614,15	ERDS2FJ472	1/4W 4.7K	2	
R617,18	ERDS2FJ472	1/4W 4.7K	2	
R619,20	ERDS2TJ124	1/4W 120K	2	
R621	ERDS2FJ154	1/4W 150K	1	
R622,23	ERDS2TJ124	1/4W 120K	2	
R624	ERDS2FJ154	1/4W 150K	1	
R627	ERDS2FJ474	1/4W 470K	1	
R628	ERDS2FJ223	1/4W 22K	1	
R631,32	ERDS2TJ392	1/4W 3.9K	2	
R635	ERDS2FJ222	1/4W 2.2K	1	
R637	ERDS2FJ153	1/4W 15K	1	
R638	ERDS2FJ683	1/4W 68K	1	
R639,40	ERDS1FJ100	1/2W 10	2	
R641,42	ERDS2FJ100	1/4W 10	2	
R643,44	ERDS1FJ100	1/2W 10	2	
R645,46	ERDS2FJ100	1/4W 10	2	
R647	ERDS2FJ271	1/4W 270	1	
R648	ERD2FCG121	1/4W 120	1	

Ref. No.	Part No.	Part Name & Description	Pcs	Remarks
R649-52	ERDS1FJ100	1/2W 10	4	
R683-86	ERDS2FJ102	1/4W 1K	4	
R687,88	ERDS2FJ152	1/4W 1.5K	2	
R691	ERDS1FJ680	1/2W 68	1	
R692,93	ERDS2FJ102	1/4W 1K	2	
R694	ERDS2FJ223	1/4W 22K	1	
R695	ERDS2FJ471	1/4W 470	1	
R696	ERDS2FJ473	1/4W 47K	1	
R708	ERDS2FJ472	1/4W 4.7K	1	
R712	ERDS2FJ222	1/4W 2.2K	1	
R719	ERDS2FJ332	1/4W 3.3K	1	
R720	ERDS2TJ392	1/4W 3.9K	1	
R721	ERD2FCJ4R7	1/4W 4.7	1	
R722	ERQ16NKW2R2E	1/6W 2.2	1	
R723	ERDS2FJ562	1/4W 5.6K	1	
R724	ERDS2TJ392	1/4W 3.9K	1	
R725	ERDS2FJ100	1/4W 10	1	
R727	ERDS2TJ392	1/4W 3.9K	1	
R729	ERDS2FJ221	1/4W 220	1	
R738	ERDS2TJ392	1/4W 3.9K	1	
R739	ERDS2FJ473	1/4W 47K	1	
R749	ERDS2FJ102	1/4W 1K	1	
R753,54	ERX1SJR47	1W 0.47	2	
R761	ERG1SJ221	1/2W 220	1	
R763	ERDS2FJ472	1/4W 4.7K	1	
R764	ERDS2FJ331	1/4W 330	1	
R765	ERDS1FJ471	1/2W 470	1	
R767	ERG1SJ270	1W 27	1	
R768	ERDS2FJ101	1/4W 100	1	
R769	ERG1SJ270	1W 27	1	
R771	ERDS2FJ222	1/4W 2.2K	1	
R772	ERDS2FJ223	1/4W 22K	1	
R773,74	ERDS1FJ180	1/2W 18	2	
R776	ERDS2FJ103	1/4W 10K	1	
R777	ERDS2FJ102	1/4W 1K	1	
R793	ERDS2TJ1R0	1/4W 1.0	1	(EE)
R794	ERDS2FJ473	1/4W 47K	1	
R794A	ERQ16NKW1R0E	1/6W 1	1	(GN)
R795	ERDS2TJ392	1/4W 3.9K	1	
R796,97	ERDS2FJ2R2	1/4W 2.2	2	
R798	ERQ16NKW2R2E	1/6W 2.2	1	
R901	ERDS2FJ821	1/4W 820	1	
R902	ERDS2FJ102	1/4W 1K	1	
R903	ERDS2FJ122	1/4W 1.2K	1	
R904	ERDS2FJ152	1/4W 1.5K	1	
R905	ERDS2FJ182	1/4W 1.8K	1	
R906	ERDS2FJ222	1/4W 2.2K	1	
R907	ERDS2FJ332	1/4W 3.3K	1	
R908	ERDS2FJ472	1/4W 4.7K	1	(GN)
R909	ERDS2FJ182	1/4W 1.8K	1	
R910	ERDS2FJ222	1/4W 2.2K	1	
R911	ERDS2FJ332	1/4W 3.3K	1	
R912	ERDS2FJ472	1/4W 4.7K	1	
R913	ERDS2FJ821	1/4W 820	1	

Ref. No.	Part No.	Part Name & Description	Pcs	Remarks
R914	ERDS2FJ102	1/4W 1K	1	
R915	ERDS2FJ122	1/4W 1.2K	1	
R916	ERDS2FJ152	1/4W 1.5K	1	
R918	ERDS2FJ103	1/4W 10K	1	
R919	ERDS2FJ153	1/4W 15K	1	
R921,22	ERDS2FJ103	1/4W 10K	2	
R924,25	ERDS2FJ102	1/4W 1K	2	
R926	ERDS2FJ222	1/4W 2.2K	1	
R928	ERDS2FJ473	1/4W 47K	1	
R929-32	ERDS2FJ102	1/4W 1K	4	
R934-36	ERDS2FJ101	1/4W 100	3	
R937	ERDS2FJ103	1/4W 10K	1	
R939	ERDS2FJ152	1/4W 1.5K	1	
R940,41	ERDS2FJ102	1/4W 1K	2	
R942	ERDS2FJ222	1/4W 2.2K	1	
R943	ERDS2FJ101	1/4W 100	1	
R944	ERDS2FJ222	1/4W 2.2K	1	
R945	ERDS2FJ101	1/4W 100	1	
R946	ERDS2FJ102	1/4W 1K	1	
R947,48	ERDS2FJ104	1/4W 100K	2	(GN)
R949	ERDS2FJ472	1/4W 4.7K	1	
R950	ERDS2FJ101	1/4W 100	1	
R951	ERDS2FJ334	1/4W 330K	1	
R952	ERDS2TJ106T	1/4W 10M	1	
R953	ERDS2FJ101	1/4W 100	1	
R954	ERDS2FJ104	1/4W 100K	1	
R956-58	ERDS2FJ102	1/4W 1K	3	
R959	ERDS2FJ470	1/4W 47	1	
R960	ERDS2FJ152	1/4W 1.5K	1	
R961,62	ERDS2FJ223	1/4W 22K	2	
R965,66	ERDS2TJ392	1/4W 3.9K	2	
R969	ERDS2TJ272T	1/4W 2.7K	1	
R974	ERDS2FJ102	1/4W 1K	1	
R975	ERDS2FJ223	1/4W 22K	1	
R976	ERDS2FJ104	1/4W 100K	1	
R986	ERDS2FJ152	1/4W 1.5K	1	
R987,88	ERDS2FJ102	1/4W 1K	2	
R990	ERDS2FJ104	1/4W 100K	1	
R991	ERDS2FJ473	1/4W 47K	1	
R992	ERDS2FJ221	1/4W 220	1	(GN)
R993,94	ERDS2FJ104	1/4W 100K	2	
R995	ERDS2FJ221	1/4W 220	1	
R996,97	ERDS2FJ151	1/4W 150	2	
R998	ERDS2FJ221	1/4W 220	1	(GN)
R999	ERDS2FJ104	1/4W 100K	1	
RL702	K6B1AEA00003	RELAY	1	
S901-08	EVQ11G05R	SW,OPERATION	8	
S909	EVQ11G05R	SW,OPERATION	1	(GN)
S910-15	EVQ11G05R	SW,OPERATION	6	
S916-18	EVQ11G05R	SW,OPERATION	3	(GN)

Ref. No.	Part No.	Part Name & Description	Pcs	Remarks
T701	ETP76VST617A	POWER TRANSFORMER	1	
T702	ETP28KBZ21BG	POWER TRANSFORMER	1	
VR401	EVUE27FK3B53	V.R.,MIC VOLUME	1	(GN)
VR901	EVQVBXFK124B	V.R.,VOLUME	1	
X151	H0H433400001	OSCILLATOR	1	(EE)
X901	EF0EC6004T4	OSCILLATOR	1	EFOEC6004T4
X902	H0A327200027	OSCILLATOR	1	
Z701	ENC471D5A	ZNR	1	J0LG00000008 
Z901	B3RAD0000028	REMOTE SENSOR	1	

15. Cabinet Parts Location

15.1. SA-DV290EE

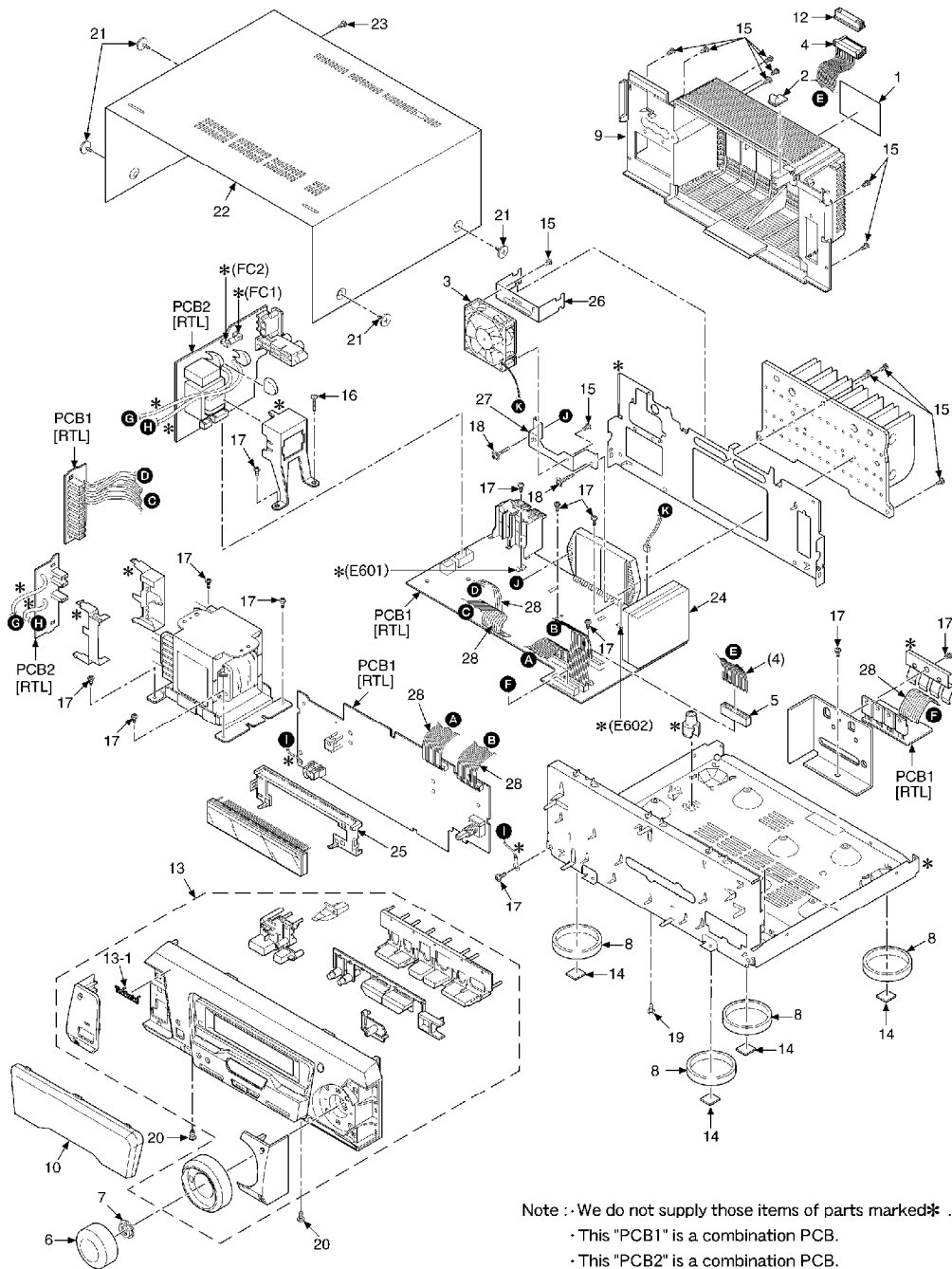

15.2. SA-DV290GN

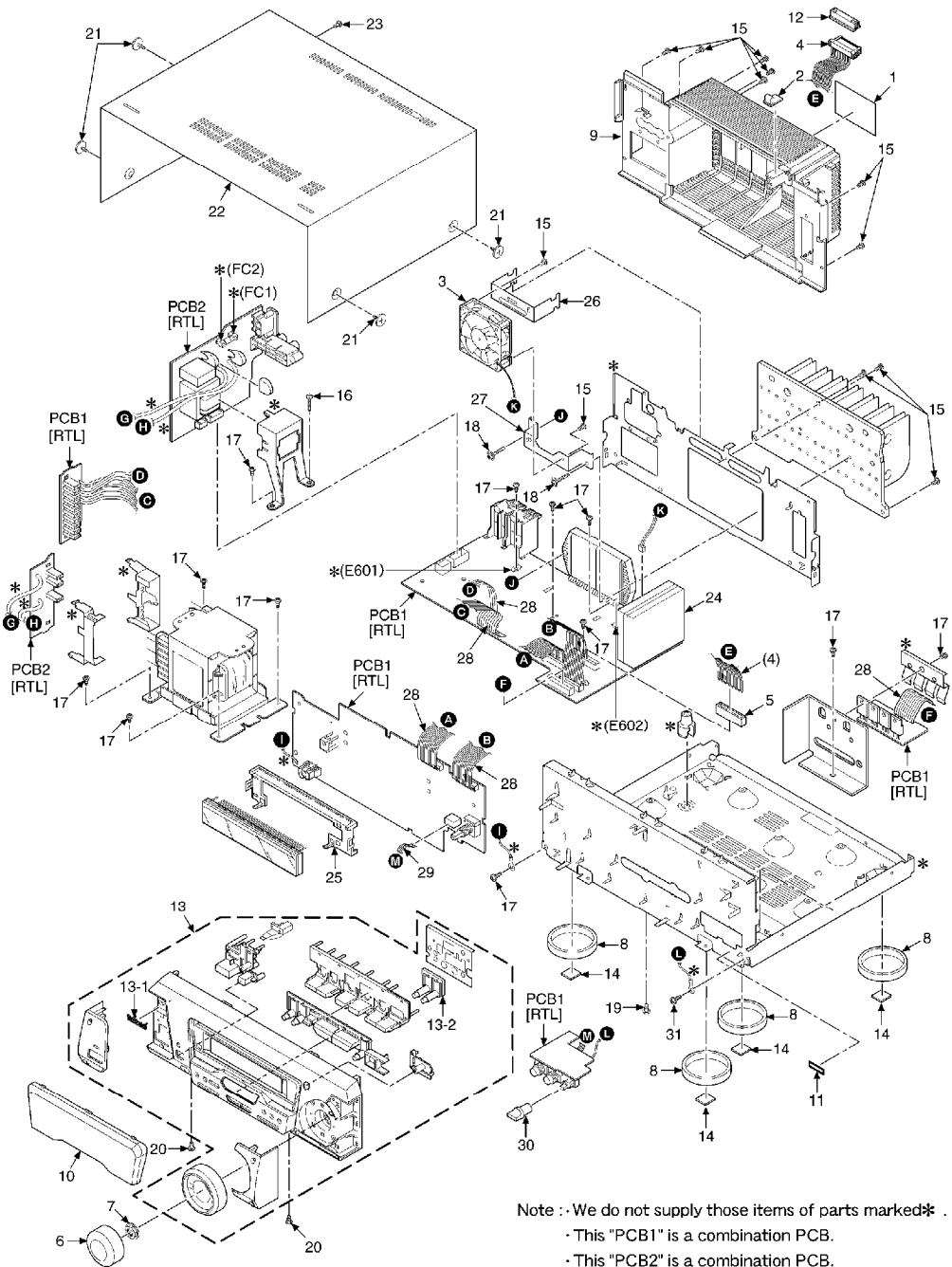

Note : - We do not supply those items of parts marked* .
 · This "PCB1" is a combination PCB.
 · This "PCB2" is a combination PCB.

16. Packaging

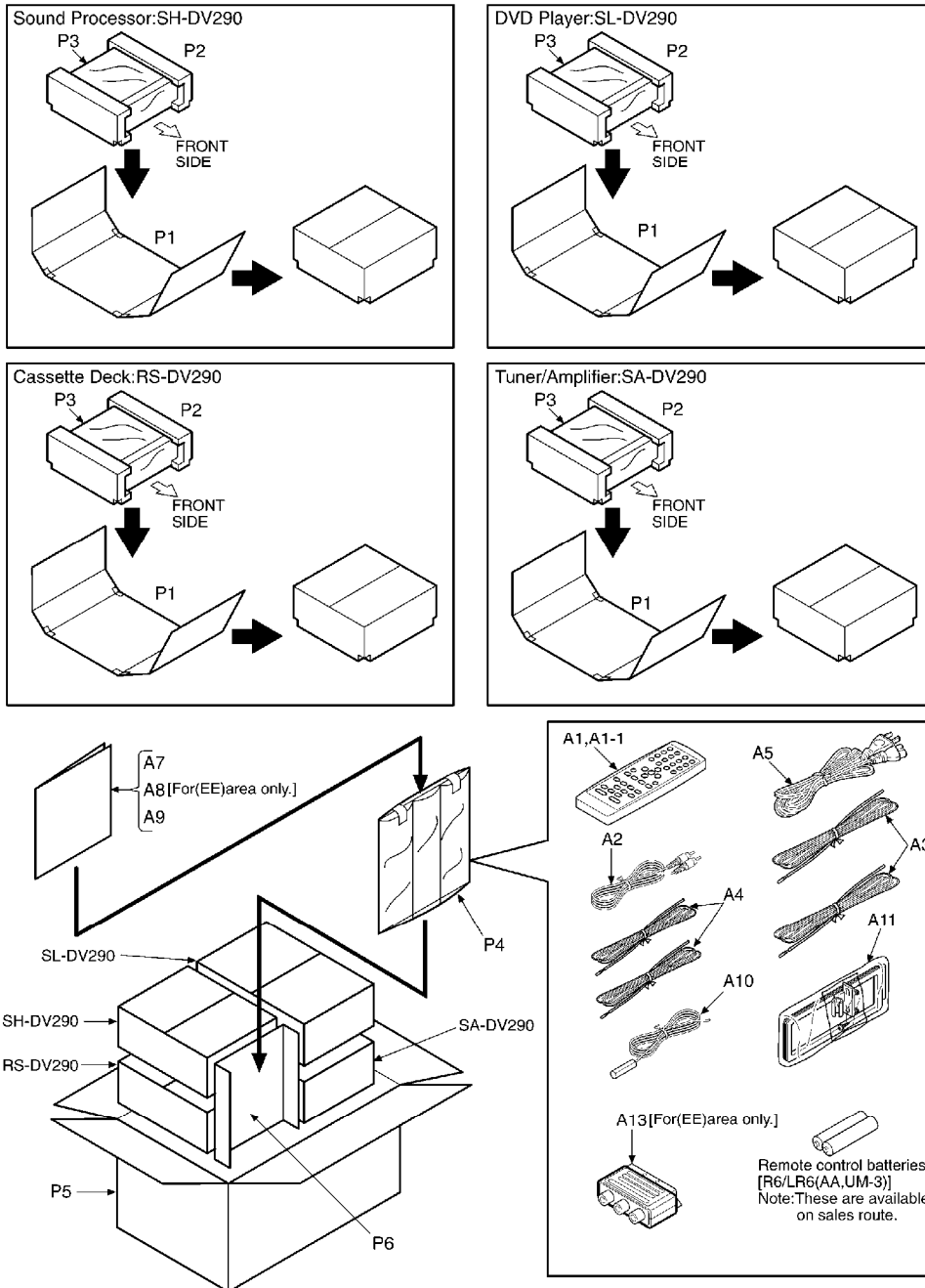

17. Schematic Diagram for printing with A4 size K0305 YH/HM

B MAIN CIRCUIT

→ : POSITIVE VOLTAGE LINE
- - - : NEGATIVE VOLTAGE LINE ⇨ : AUDIO SIGNAL LINE

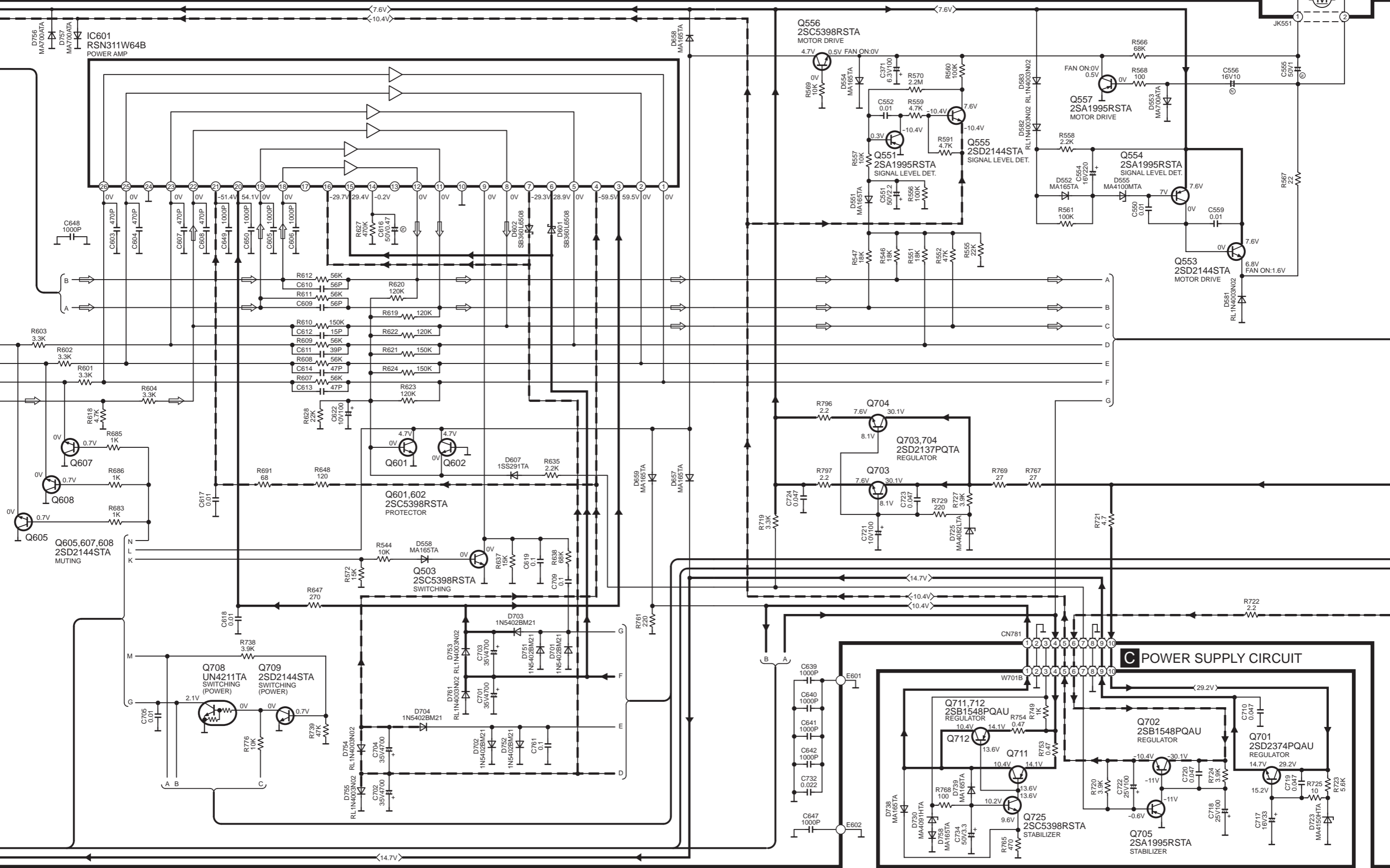

C POWER SUPPLY CIRCUIT

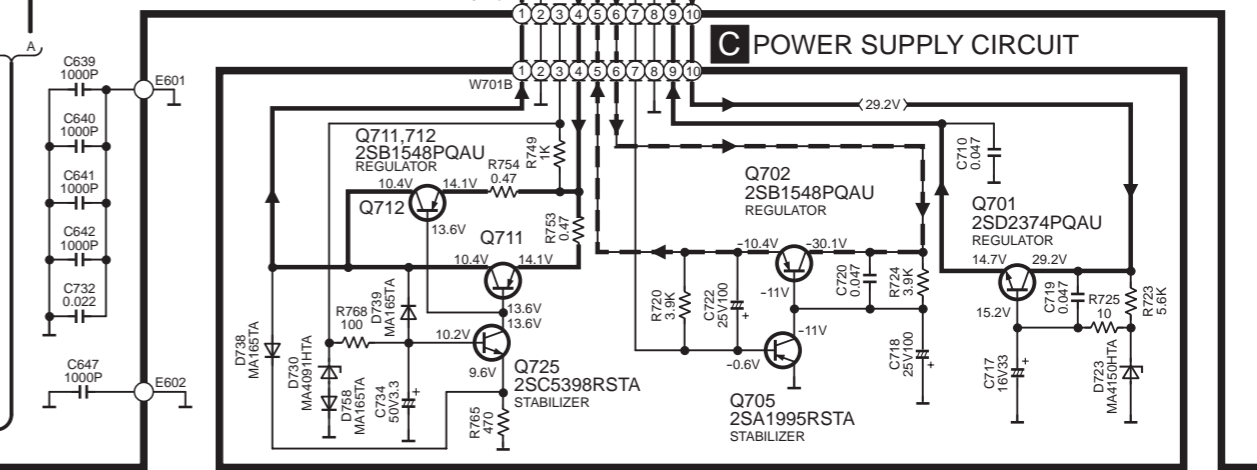

B MAIN CIRCUIT

— : POSITIVE VOLTAGE LINE
 - - - : NEGATIVE VOLTAGE LINE
 ⇨ : AUDIO SIGNAL LINE

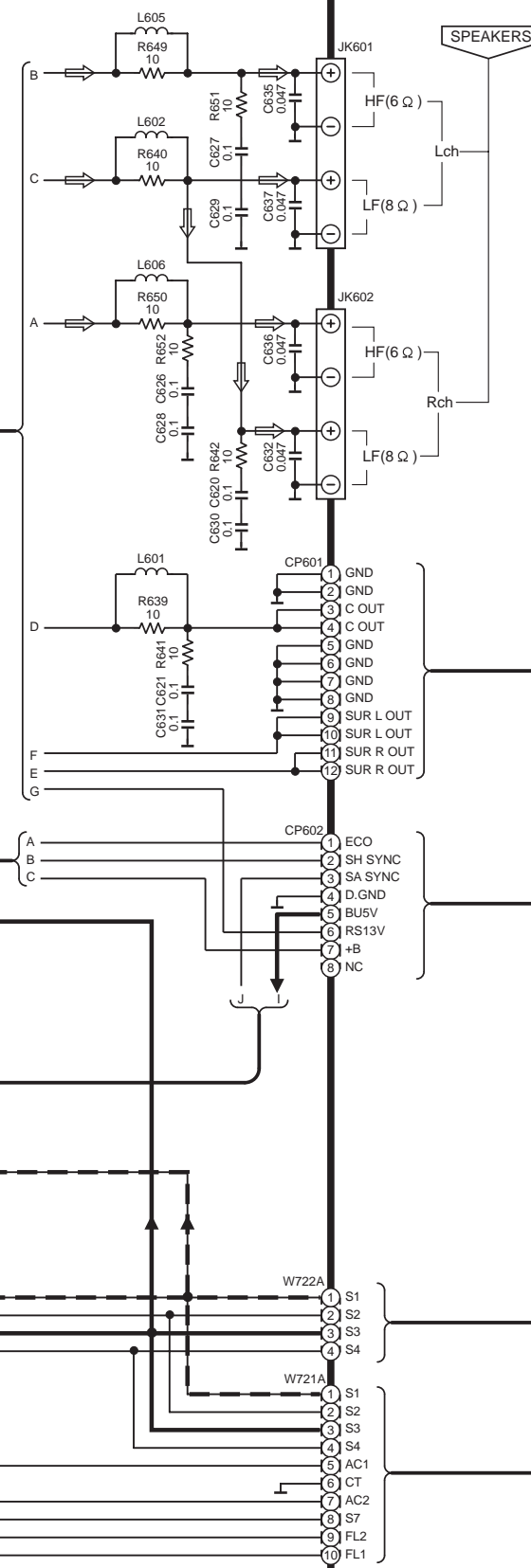

D AC IN CIRCUIT

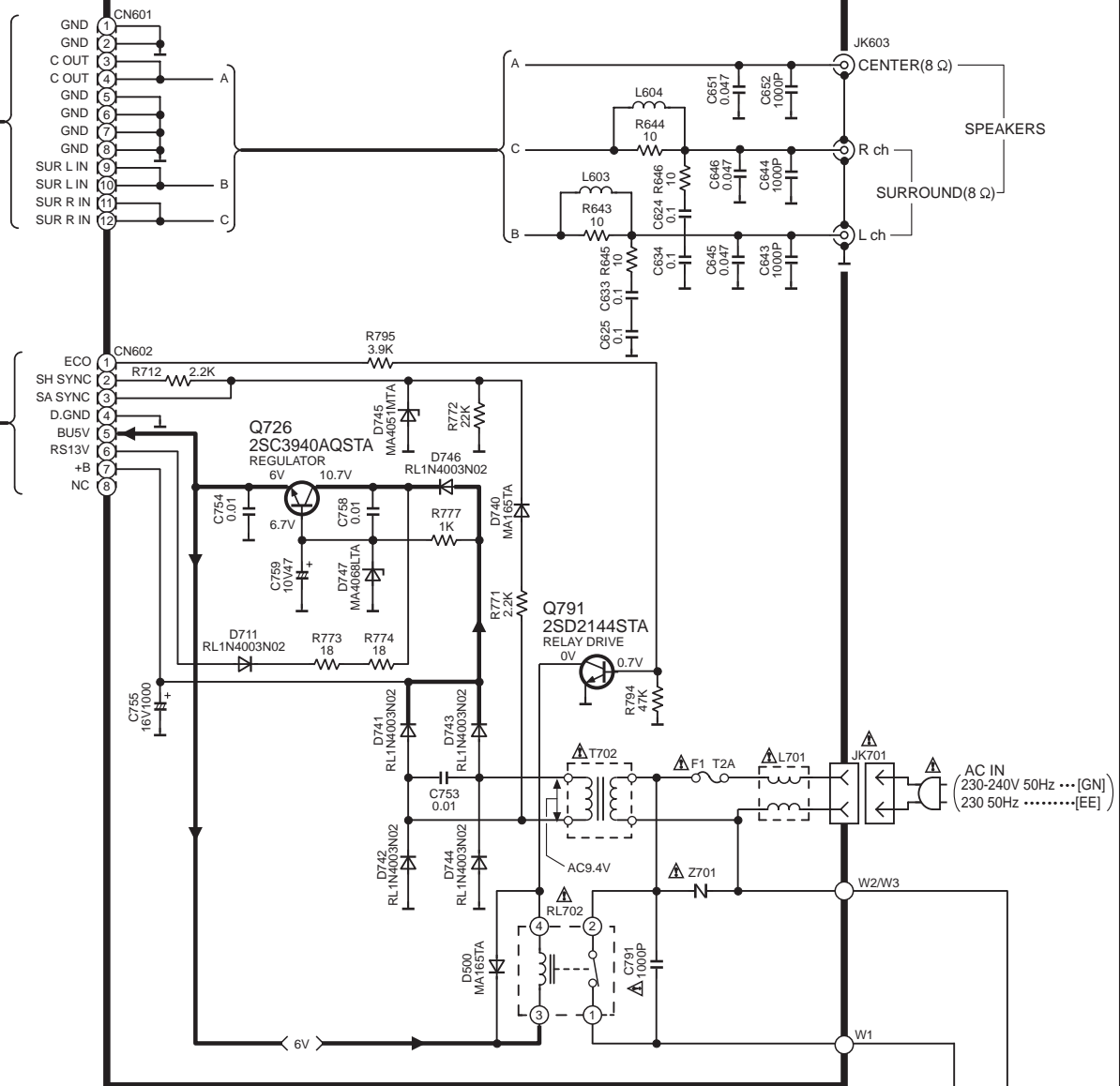

E POWER TRANSFORMER (A) CIRCUIT

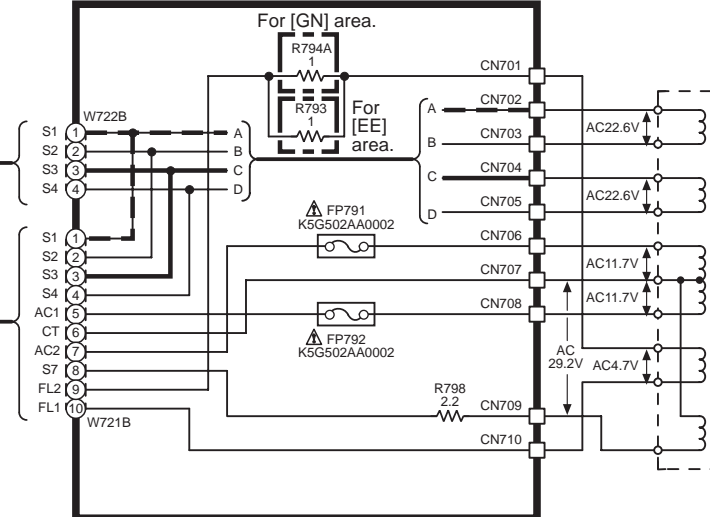

F POWER TRANSFORMER (B) CIRCUIT

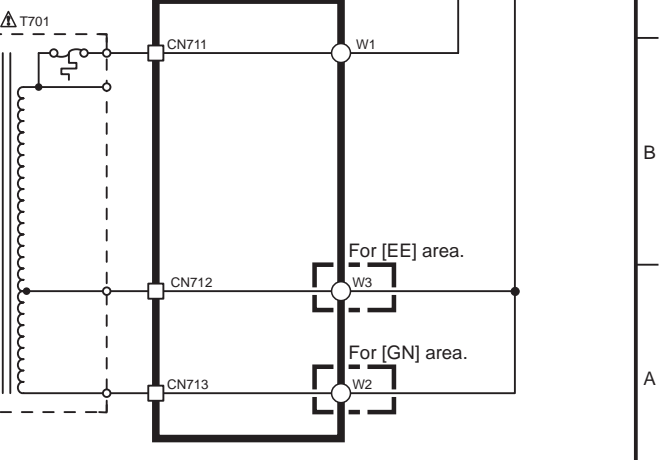

→ : POSITIVE VOLTAGE LINE -→ : NEGATIVE VOLTAGE LINE ⇨ : AUDIO SIGNAL LINE ⇨ : MIC SIGNAL LINE

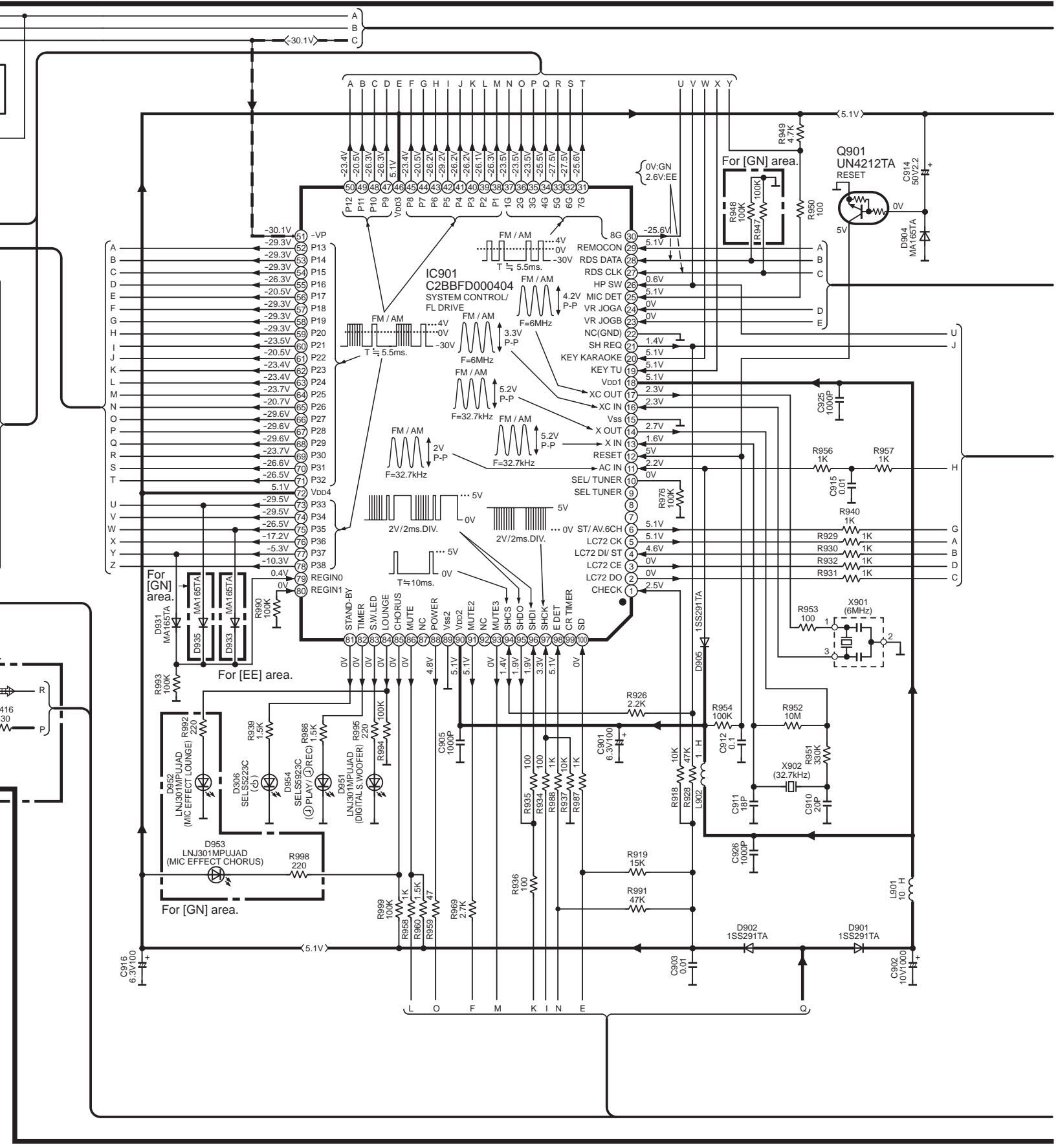

SA-DV290(E,E,GN) OPERATION, MIC JACK CIRCUIT DIAGRAM

A OPERATION CIRCUIT

: NEGATIVE VOLTAGE LINE : AUDIO SIGNAL LINE : MIC SIGNAL LINE
 : POSITIVE VOLTAGE LINE : TUNER SIGNAL LINE

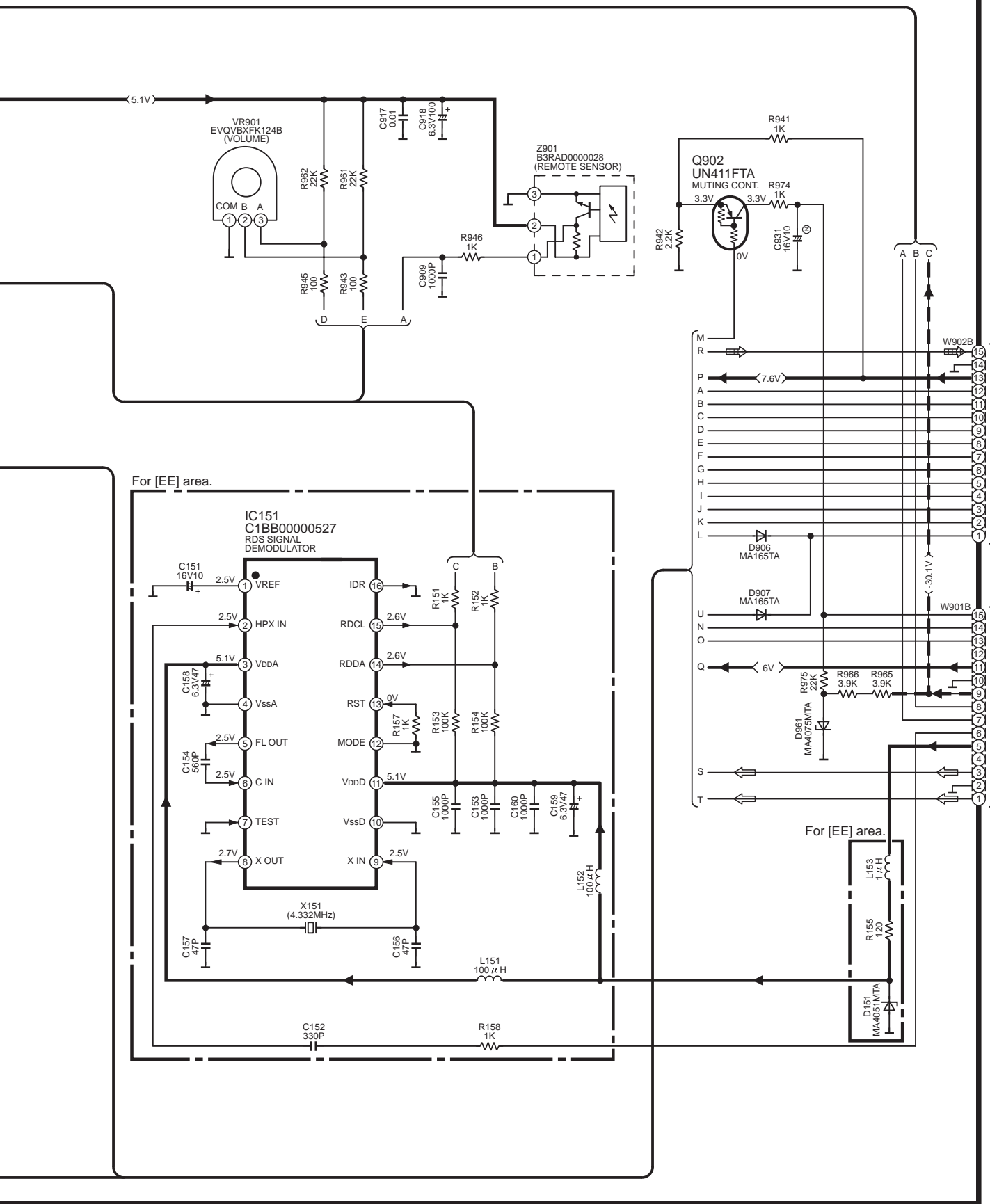

TUNER Lch
 TUNER Rch
 A.GN
 Lch
 Rch
 +B(10)
 SUR
 SUR
 S.
 M
 -B(-10)
 V.GN
 D.GN
 CS/RE
 CI
 DA
 CT GN
 SH F
 SH F
 SYN

To SOUND PROCESSOR (SH-DV290)

For [EE] area.

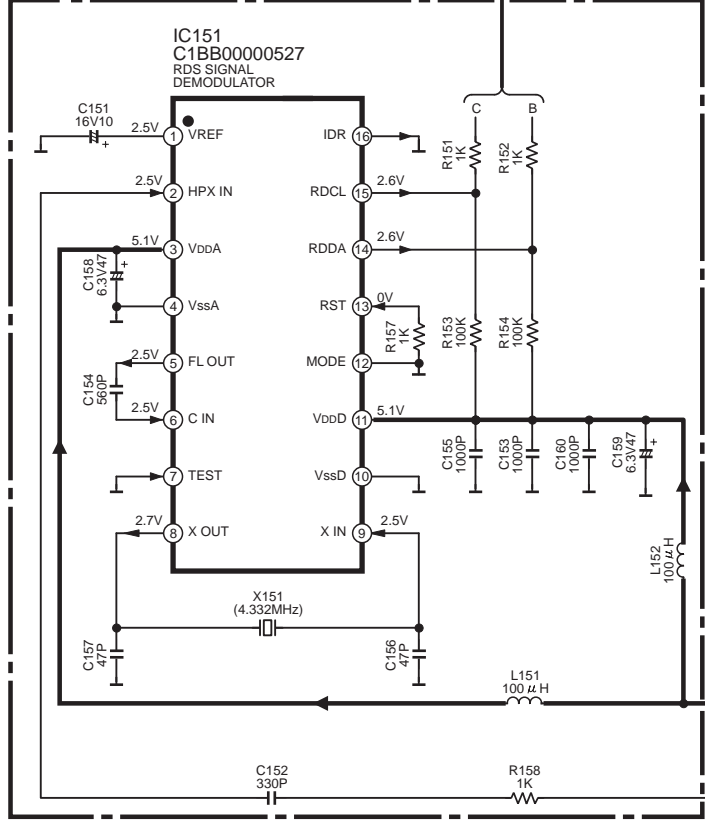

For [EE] area.

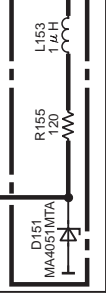

Z101
 RAN005EM-2 ...[EE]
 ENG0650Q ...[GN]
 (TUNER PACK)

- T.GND (1)
- +B(1) (2)
- SD (3)
- +B(2) (4)
- DET (5)
- Rch (6)
- CE (7)
- Lch (8)
- DI (9)
- DO (10)
- CL (11)

B MAIN CIRCUIT

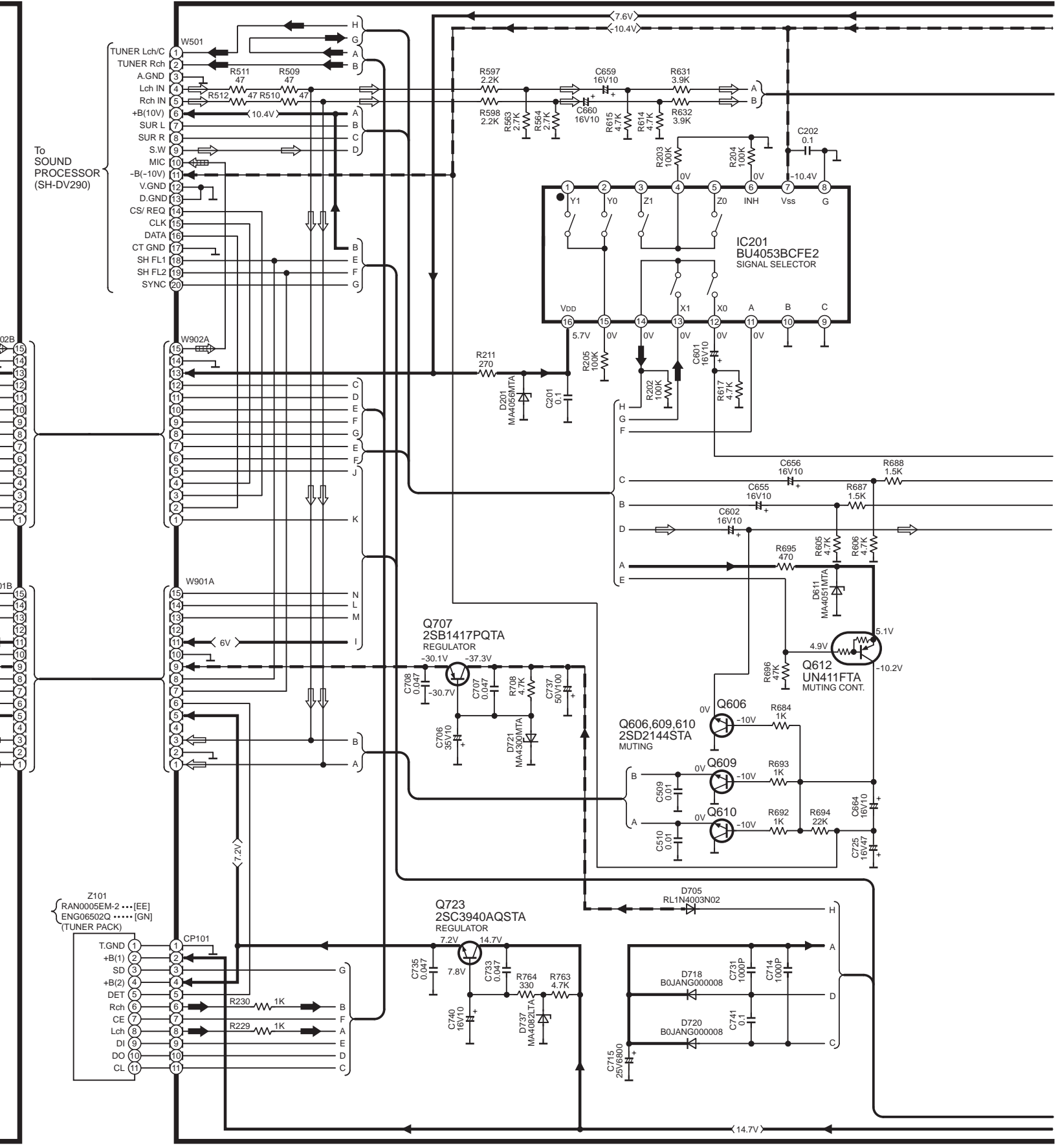

B MAIN CIRCUIT

→ : POSITIVE VOLTAGE LINE
- - - : NEGATIVE VOLTAGE LINE ⇨ : AUDIO SIGNAL LINE

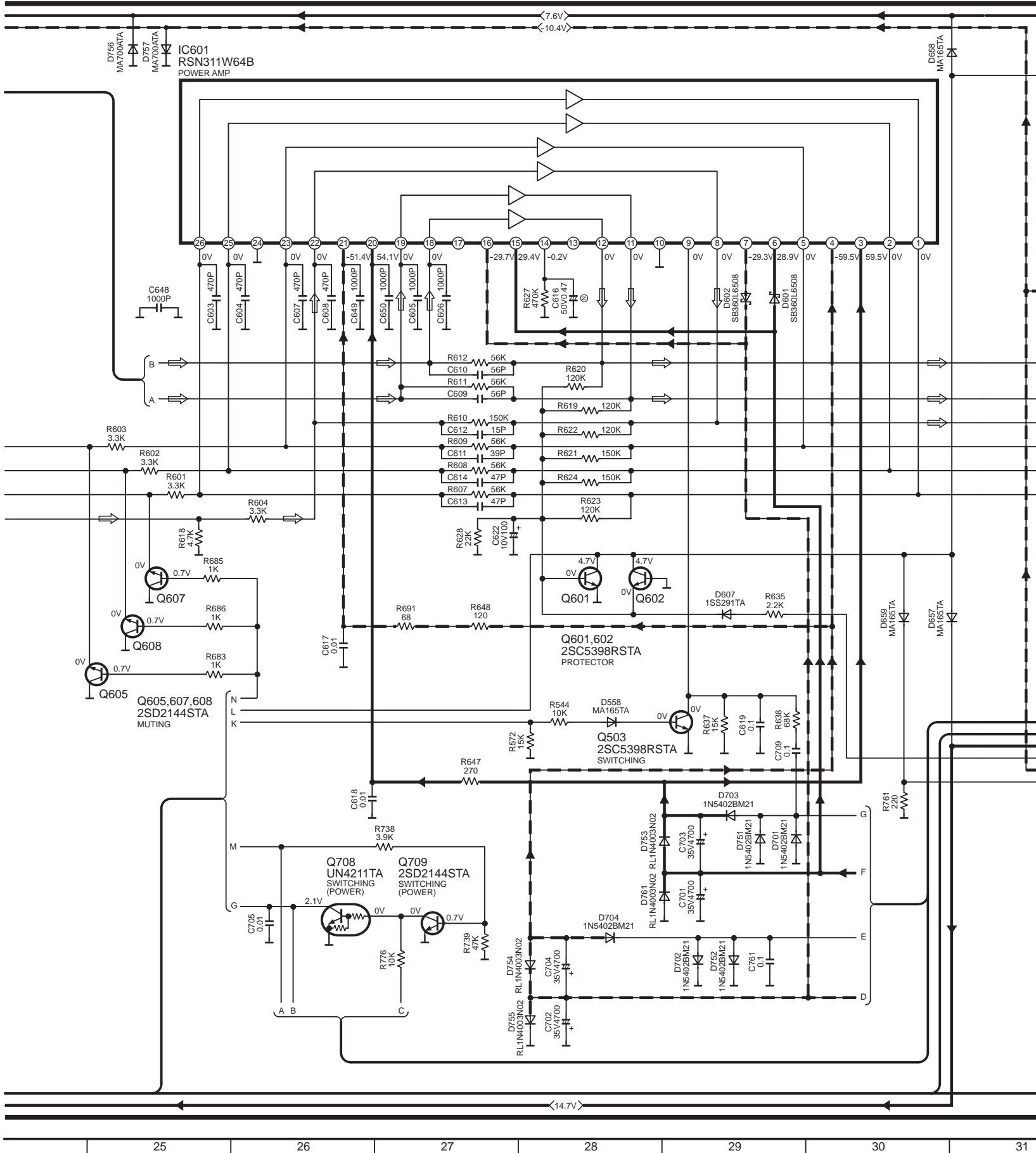

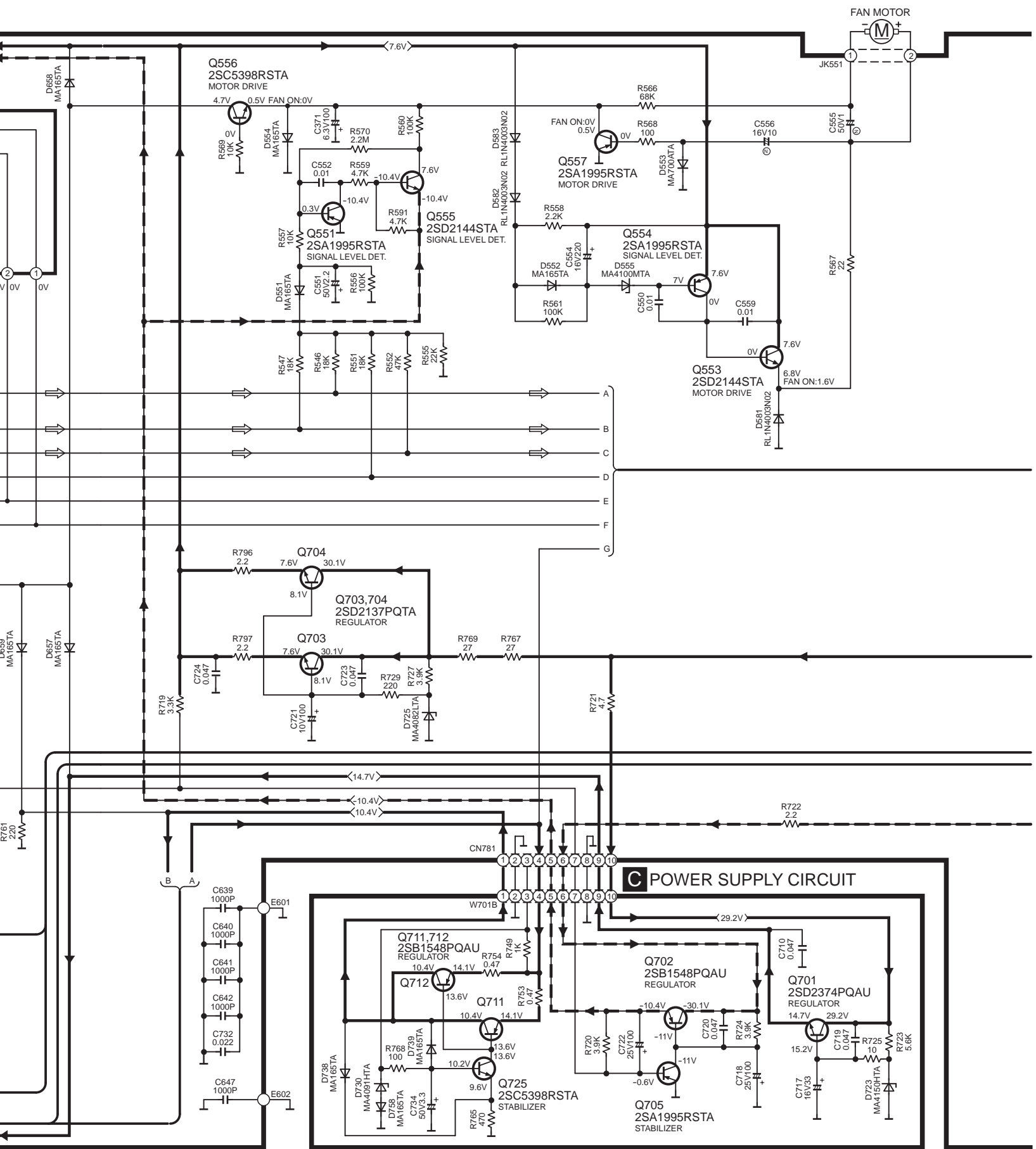

SA-DV290(EE,GN) MAIN POWER SUPPLY CIRCUIT DIAGRAM

B MAIN CIRCUIT

—▶ : POSITIVE VOLTAGE LINE
 -▶ : NEGATIVE VOLTAGE LINE
 ◻▶ : AUDIO SIGNAL LINE

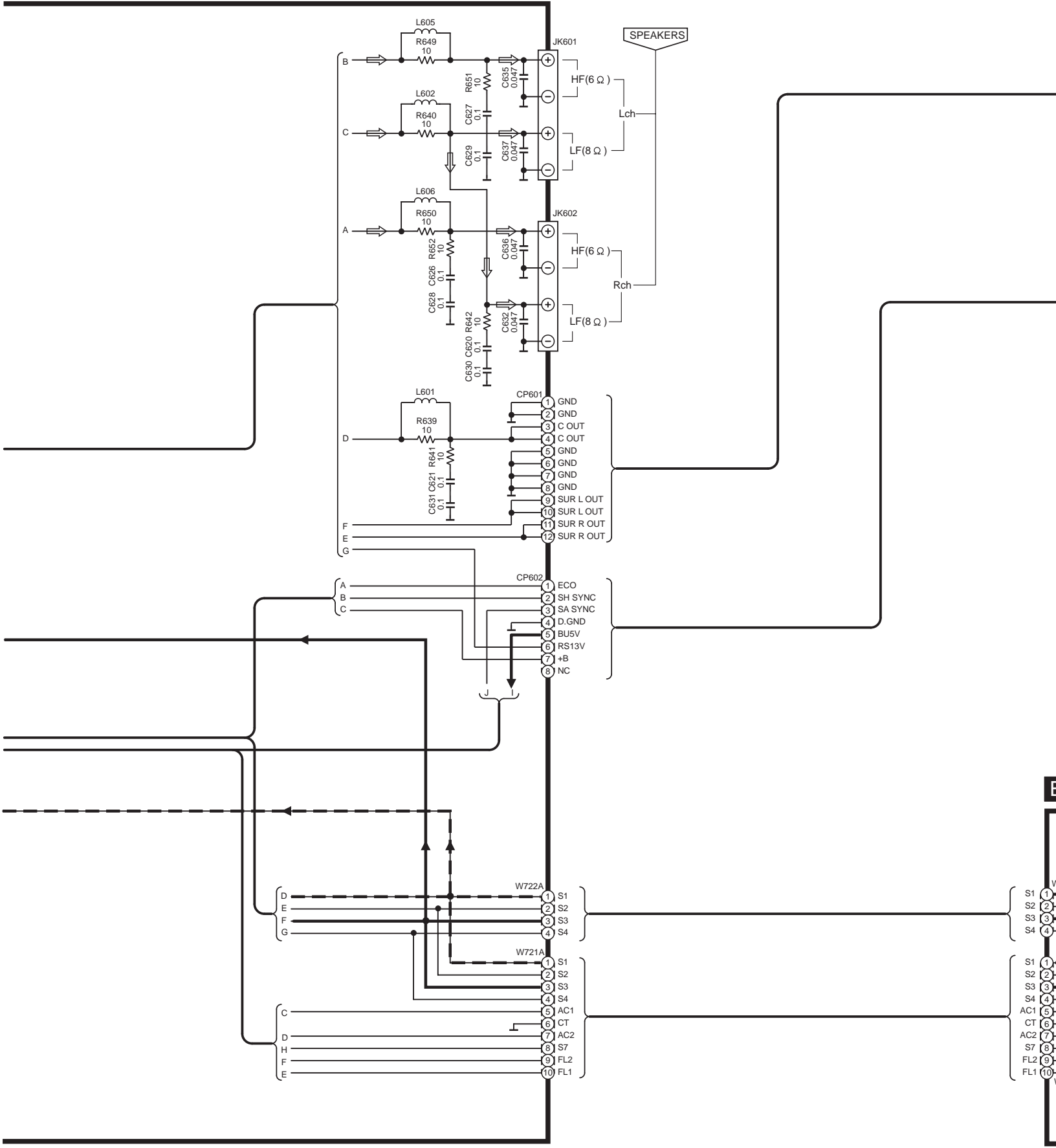

D AC IN CIRCUIT

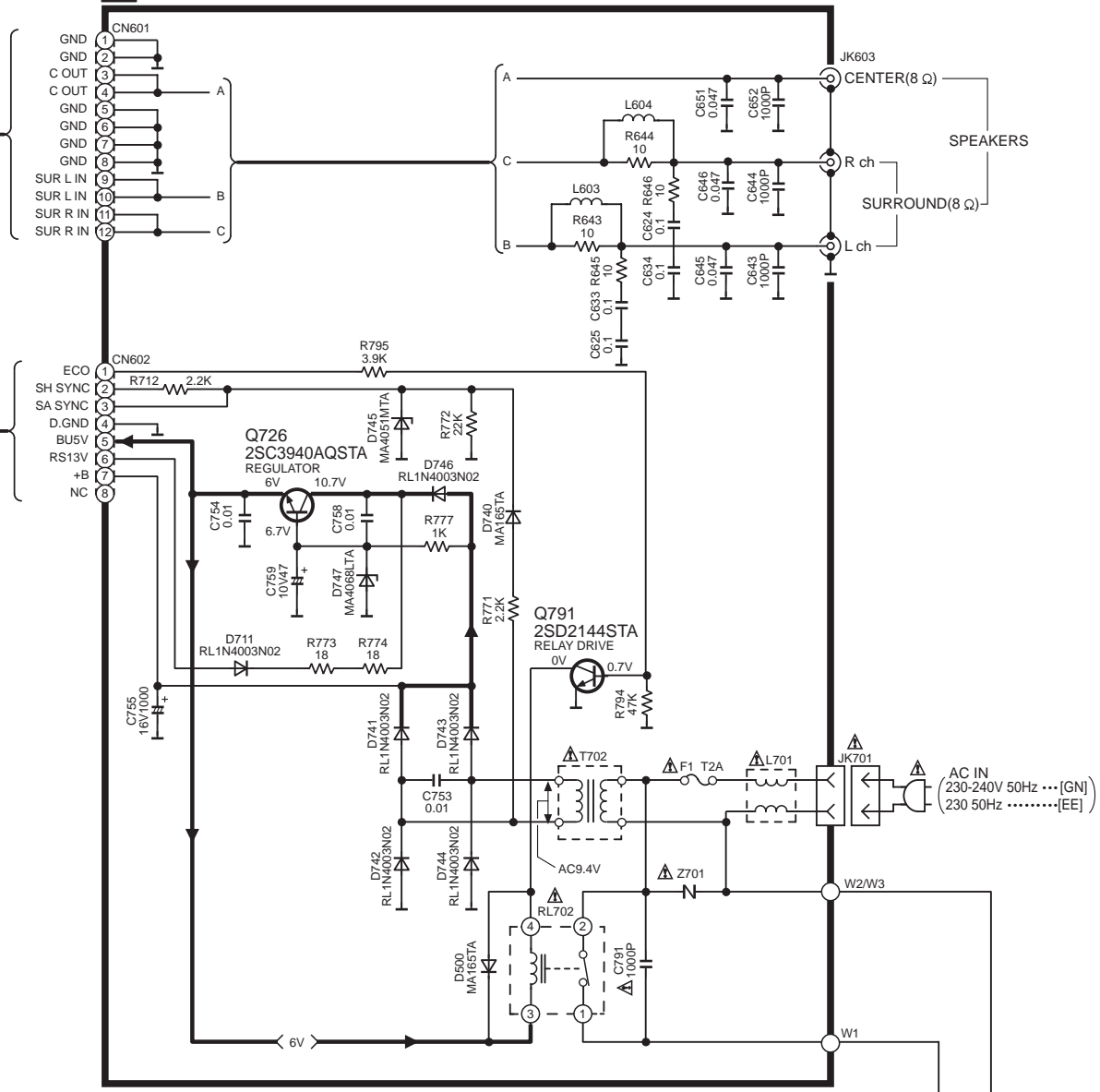

E POWER TRANSFORMER (A) CIRCUIT

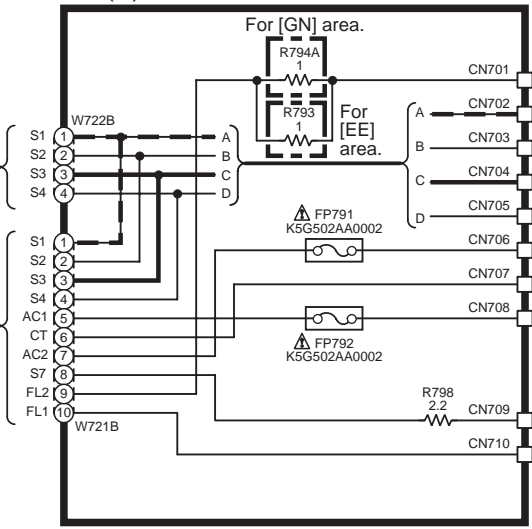

F POWER TRANSFORMER (B) CIRCUIT

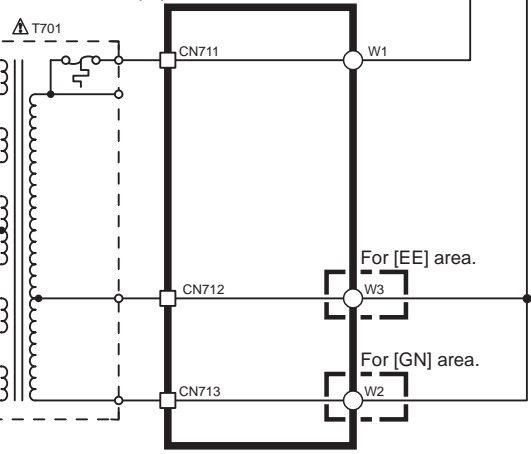

SA-DV290(EE,GN) MAIN, AC IN, POWER TRANSFORMER(A)&(B) CIRCUIT DIAGRAM

BU4053BCFE2
C1BB00000527

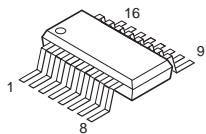

C2BBFD000404

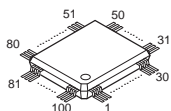

RSN311W64B

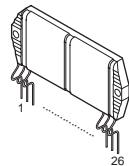

TA2011S

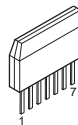

2SB1417PQTA
2SD2137PQTA

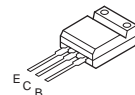

2SD2144STA

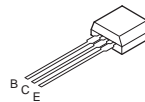

2SA1995RSTA
2SC5398RSTA

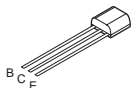

2SC3940AQSTA

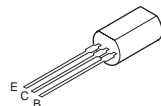

2SB1548PQAU
2SD2374PQAU

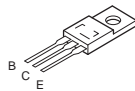

UN411FTA
UN4211TA
UN4212TA



1SS291TA
MA700ATA

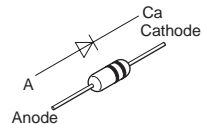

MA4100MTA
MA4150HTA
MA4300MTA

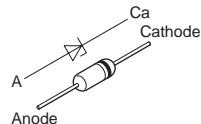

SB360L6508

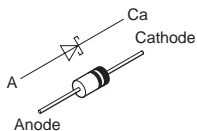

1N5402BM21
RL1N4003N02
B0JANG000008

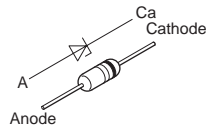
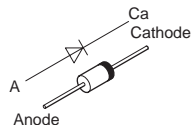

MA4030MTA
MA4051MTA
MA4056MTA
MA4068LTA
MA4075MTA
MA4082LTA
MA4091HTA

LNJ301MPUJAD

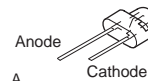

MA165TA

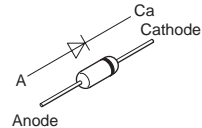

SELS5223C
SELS5923C

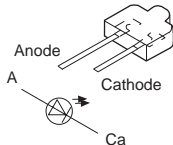

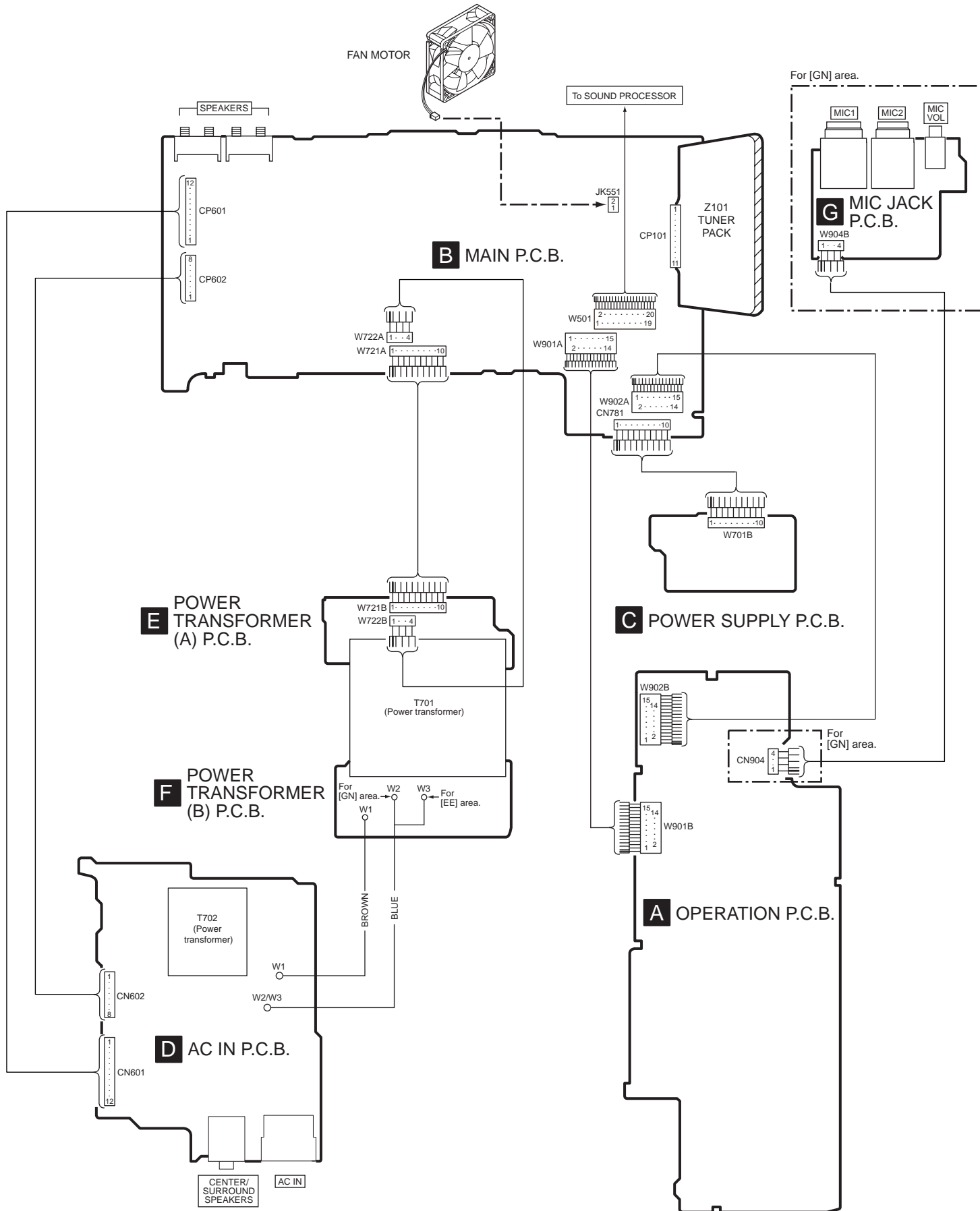

FAN MOTOR

To SOUND PROCESSOR

For [GN] area.

B MAIN P.C.B.

E POWER TRANSFORMER (A) P.C.B.

F POWER TRANSFORMER (B) P.C.B.

C POWER SUPPLY P.C.B.

A OPERATION P.C.B.

D AC IN P.C.B.

CENTER/SURROUND SPEAKERS

AC IN

A

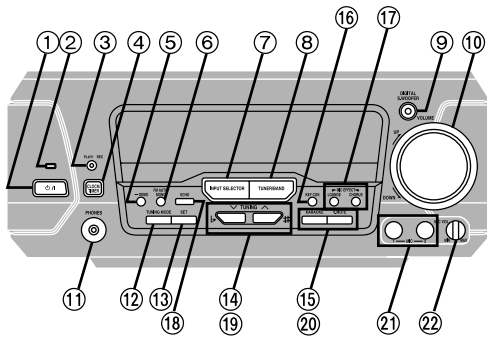

A Stereo tuner/amplifier

- ① **Standby/on switch (⏻/⏻)**
Press to switch the unit from on to standby mode or vice versa. In standby mode, the unit is still consuming a small amount of power.
 - ② **Standby indicator (⏻)**
When the unit is connected to the AC mains supply, this indicator lights up in standby mode and goes out when the unit is turned on.
 - ③ **Play timer/record timer button and indicator (⏻/⏻)**
 - ④ **Clock/timer button (CLOCK/TIMER)**
 - ⑤ **Demo button (-DEMO)**
 - ⑥ **FM mode button (FM AUTO/MONO)**
 - ⑦ **Source input button (INPUT SELECTOR)**
 - ⑧ **Tuner/band button (TUNER/BAND)**
 - ⑨ **Digital super woofer button and indicator (DIGITAL S.WOOFER)**
 - ⑩ **Volume control (VOLUME)**
 - ⑪ **Headphone jack (PHONES)**
 - ⑫ **Tuning mode button (TUNING MODE)**
 - ⑬ **Set button (SET)**
- [For (EE) area]**
- ⑭ **Tuning buttons (∇, ▲ TUNING)**
 - ⑮ **RDS display mode button (RDS, PS-DISP MODE-PTY)**
- [For (GN) area]**
- ⑯ **Key control button (KEY CON)**
 - ⑰ **MIC effect buttons (MIC EFFECT, LOUNGE, CHORUS)**
 - ⑱ **Echo button (ECHO)**
 - ⑲ **Tuning, Key up/down buttons (∇, ▲ TUNING, ♭, #)**
 - ⑳ **KARAOKE, Voice mute buttons (KARAOKE, V.MUTE)**
 - ㉑ **Microphone jacks (1-MIC-2)**
 - ㉒ **Microphone volume control (MIC VOL)**

B

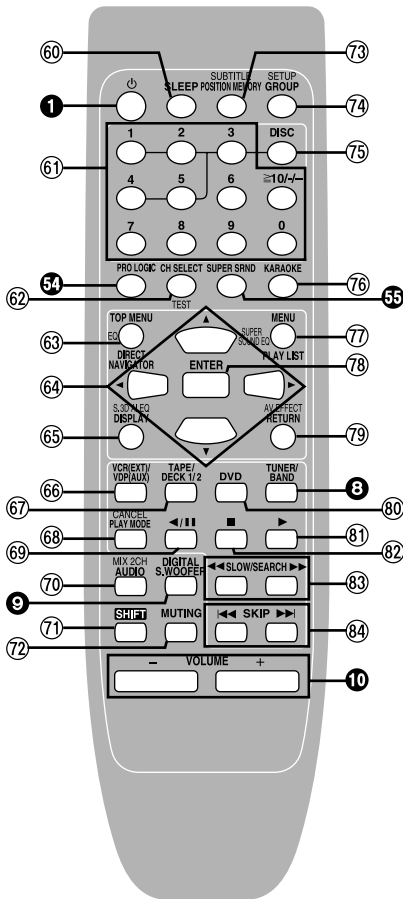

B Remote control

Buttons ①, ③, ⑨, ⑩, ⑤④ and ⑤⑤ function in the same way as the controls on the main unit.

- ⑥① **Sleep timer button (SLEEP)**
- ⑥② **Numbered buttons (1-9, 0, ≧10/-/-)**
- ⑥③ **Channel select, Test signal button (CH SELECT, TEST)**
- ⑥④ **Top menu, Direct navigator, EQ button (TOP MENU, DIRECT NAVIGATOR, EQ)**
- ⑥⑤ **Cursor buttons (◀, ▶, ▲, ▼)**
- ⑥⑥ **Display, Super 3D AI EQ button (DISPLAY, S.3D AI EQ)**
- ⑥⑦ **Input select button [VCR (EXT)/VDP (AUX)]**
- ⑥⑧ **Tape select, deck 1/deck 2 select button (TAPE/DECK 1/2)**
- ⑥⑨ **Play mode, Cancel button (PLAY MODE, CANCEL)**
- ⑦① **Disc pause, Tape reverse play button (◀/||)**
- ⑦② **Audio select, 2 channel down mixing button (AUDIO, MIX 2CH)**
- ⑦③ **Shift button (SHIFT)**
To operate functions labeled in orange, press [SHIFT] and then the corresponding button at the same time.
- ⑦④ **Muting button (MUTING)**
- ⑦⑤ **Position memory, Subtitle select button (POSITION MEMORY, SUBTITLE)**
- ⑦⑥ **Group, Initial setting button (GROUP, SETUP)**
- ⑦⑦ **Disc button (DISC)**
- ⑦⑧ **[For (GN) area]**
Karaoke, Karaoke effect button (KARAOKE, KARAOKE EFFECT)
- ⑦⑨ **Menu, Play list, Super sound EQ button (MENU, PLAY LIST, SUPER SOUND EQ)**
- ⑦⑩ **Enter button (ENTER)**
- ⑦⑪ **Return, AV effect button (RETURN, AV EFFECT)**
- ⑦⑫ **DVD button (DVD)**
- ⑦⑬ **Disc play, Tape forward play button (▶)**
- ⑦⑭ **Disc stop, Tape stop button (■)**
- ⑦⑮ **Disc slow/search buttons (◀◀, ▶▶ SLOW/SEARCH)**
- ⑦⑯ **Disc skip buttons (◀◀◀, ▶▶▶ SKIP)**

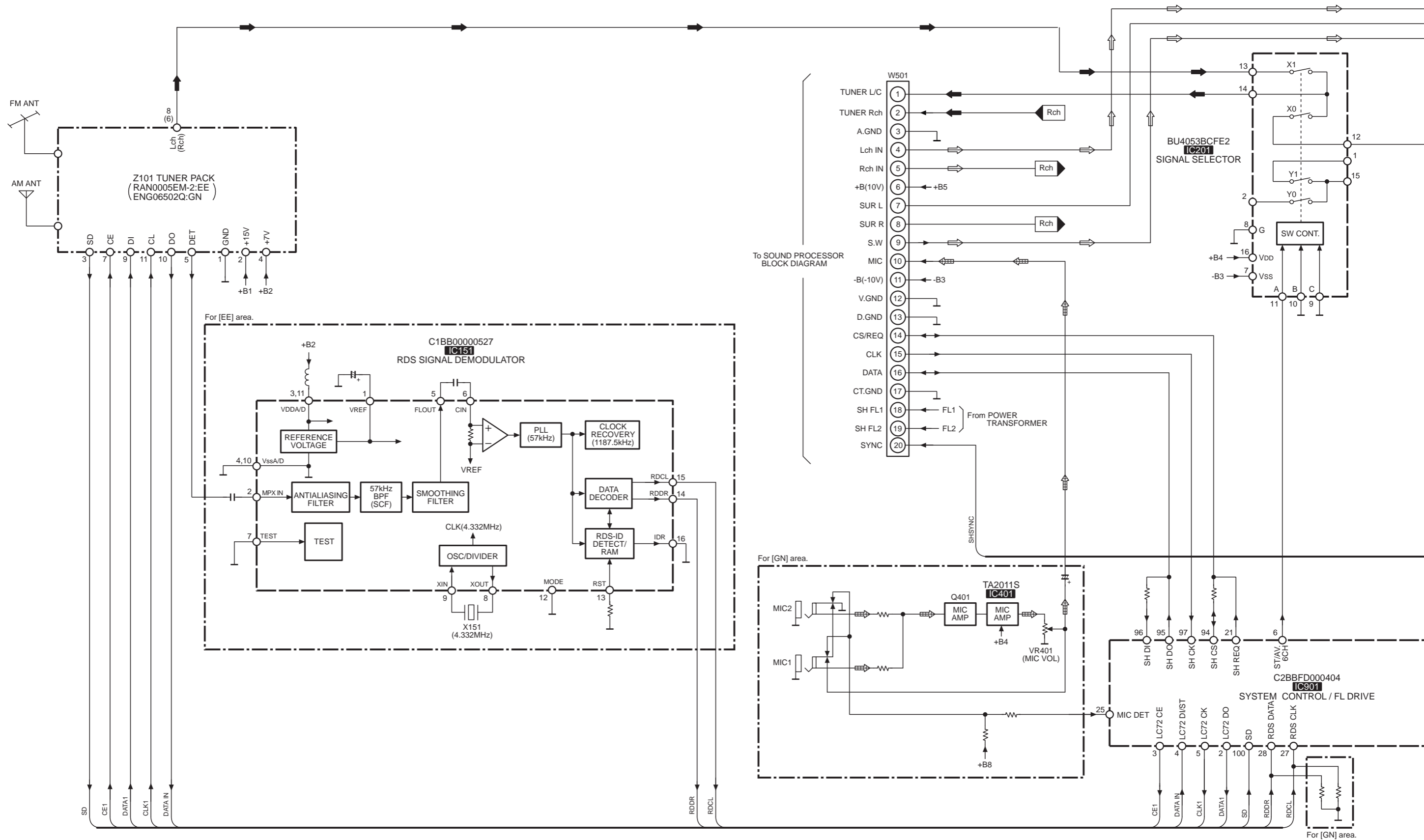

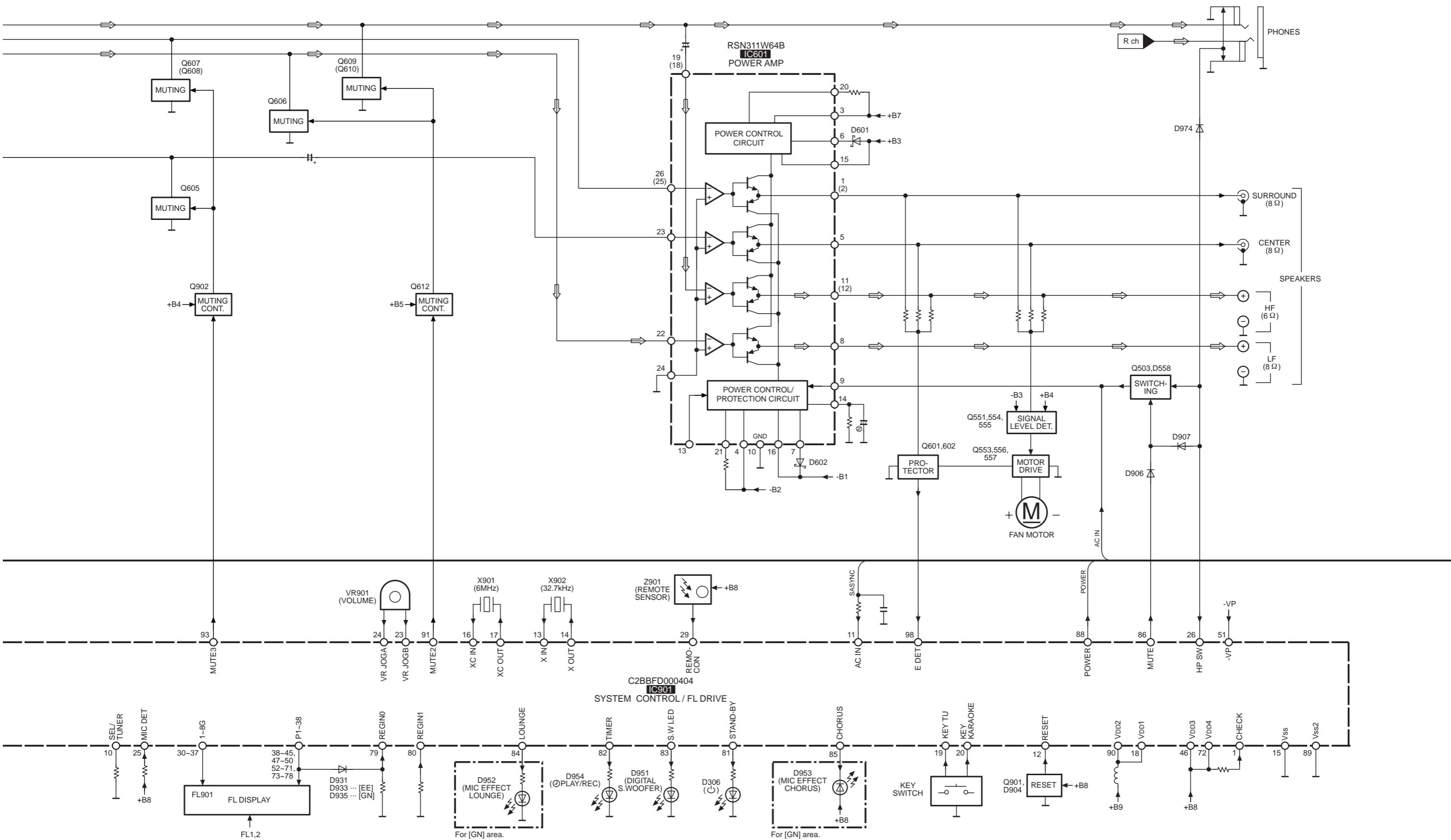

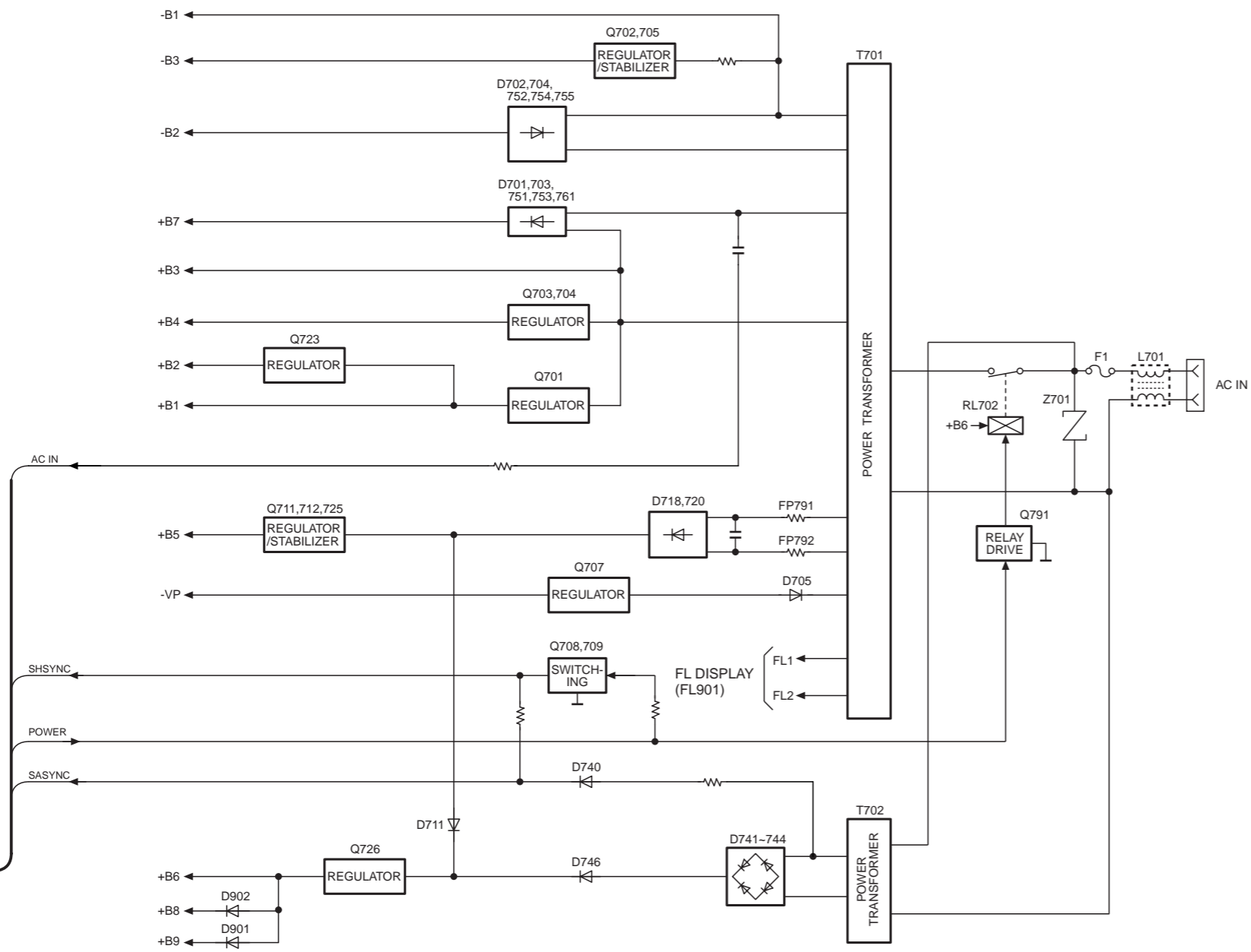

NOTES : ● SIGNAL LINE
 ⇨ : AUDIO SIGNAL
 ⇨ : TUNER SIGNAL
 ⇨ : MIC SIGNAL
 ● () indicates pin No. Right channel.

C POWER SUPPLY P.C.B.

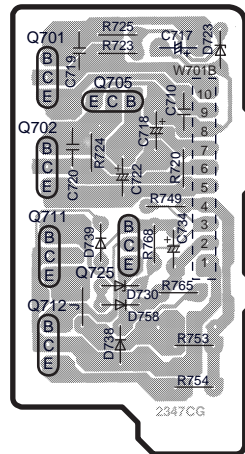

(REP3337K-M [EE])
(REP3337L-M [GN])

E POWER TRANSFORMER (A) P.C.B.

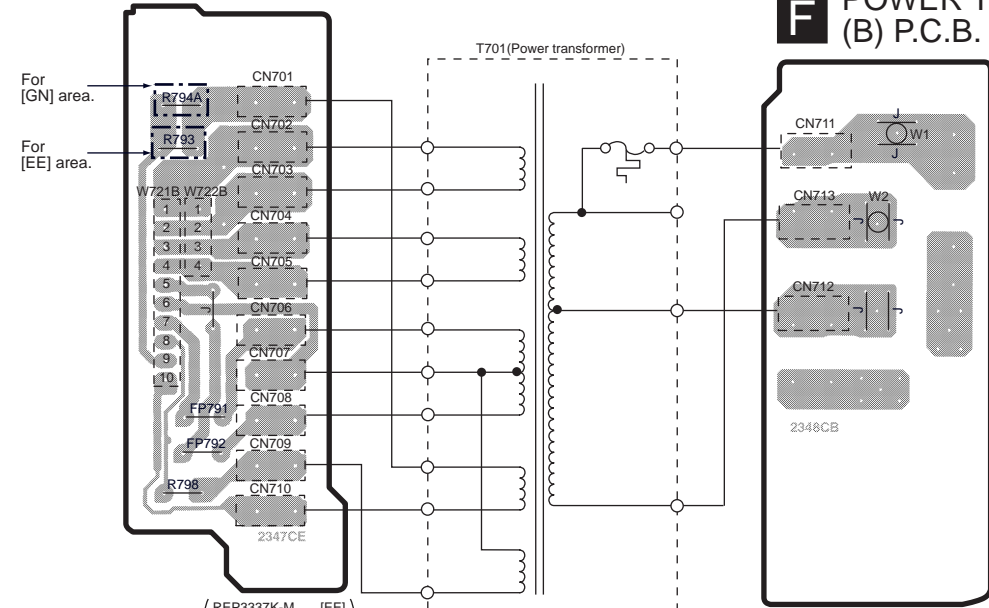

(REP3337K-M [EE])
(REP3337L-M [GN])

F POWER TRANSFORMER (B) P.C.B.

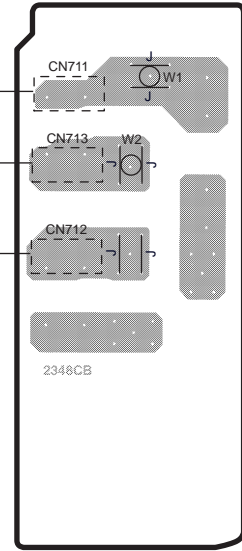

(REP3338A-S [EE])
(REP3338B-S [GN])

D AC IN P.C.B.

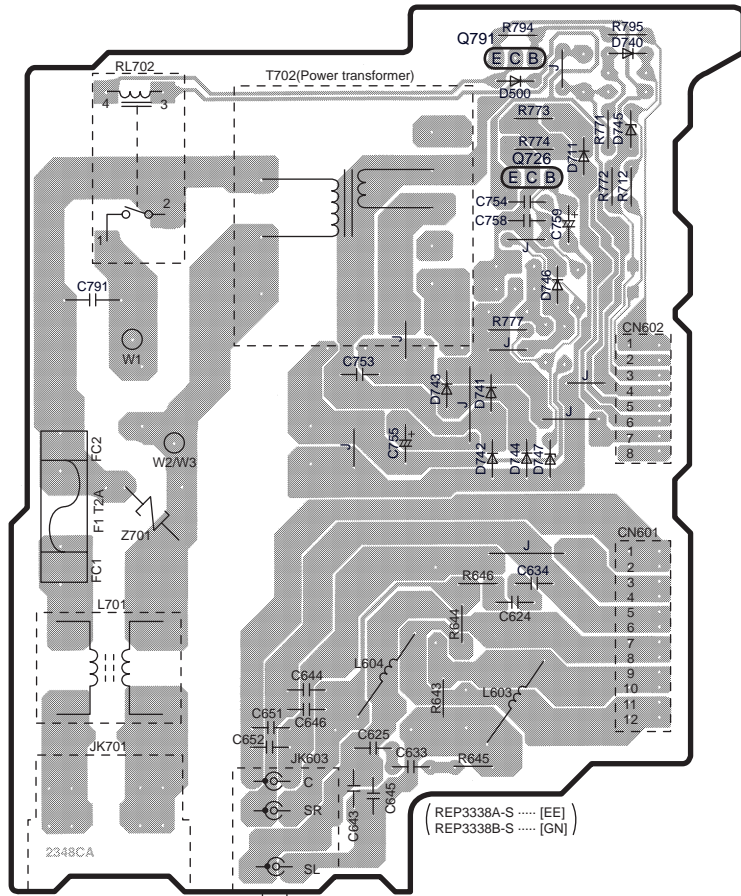

(REP3338A-S [EE])
(REP3338B-S [GN])

AC IN
(230V 50Hz [EE])
(230-240V 50Hz [GN])

CENTER/SURROUND SPEAKERS

G MIC JACK P.C.B.
For [GN] area.

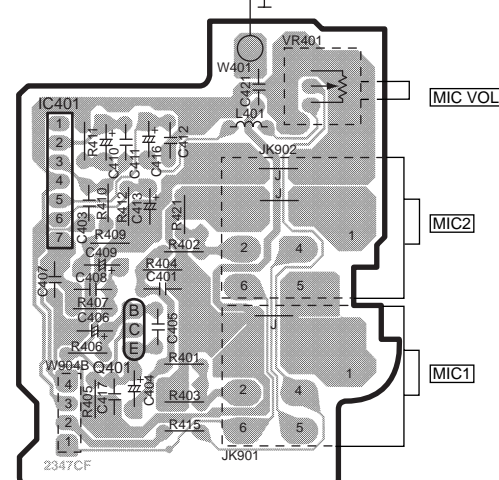

(REP3337L-M)

A OPERATION CIRCUIT

→ : POSITIVE VOLTAGE LINE -→ : NEGATIVE VOLTAGE LINE ⇨ : AUDIO SIGNAL LINE ⇨ : MIC SIGNAL LINE

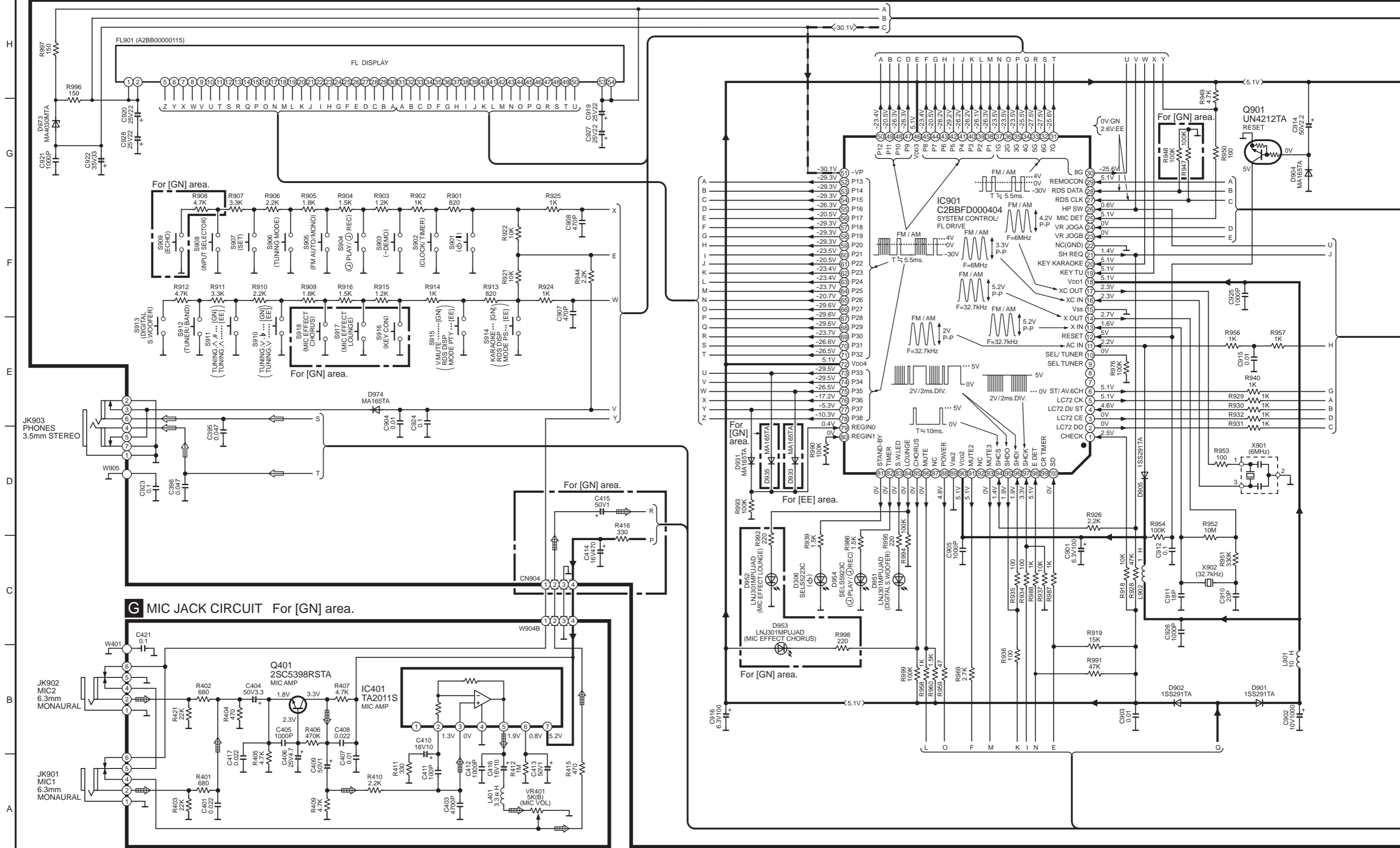

A OPERATION CIRCUIT

- - - : NEGATIVE VOLTAGE LINE
 - - - : POSITIVE VOLTAGE LINE
 ⇨ : AUDIO SIGNAL LINE
 ⇨ : MIC SIGNAL LINE
 ⇨ : TUNER SIGNAL LINE

B MAIN CIRCUIT

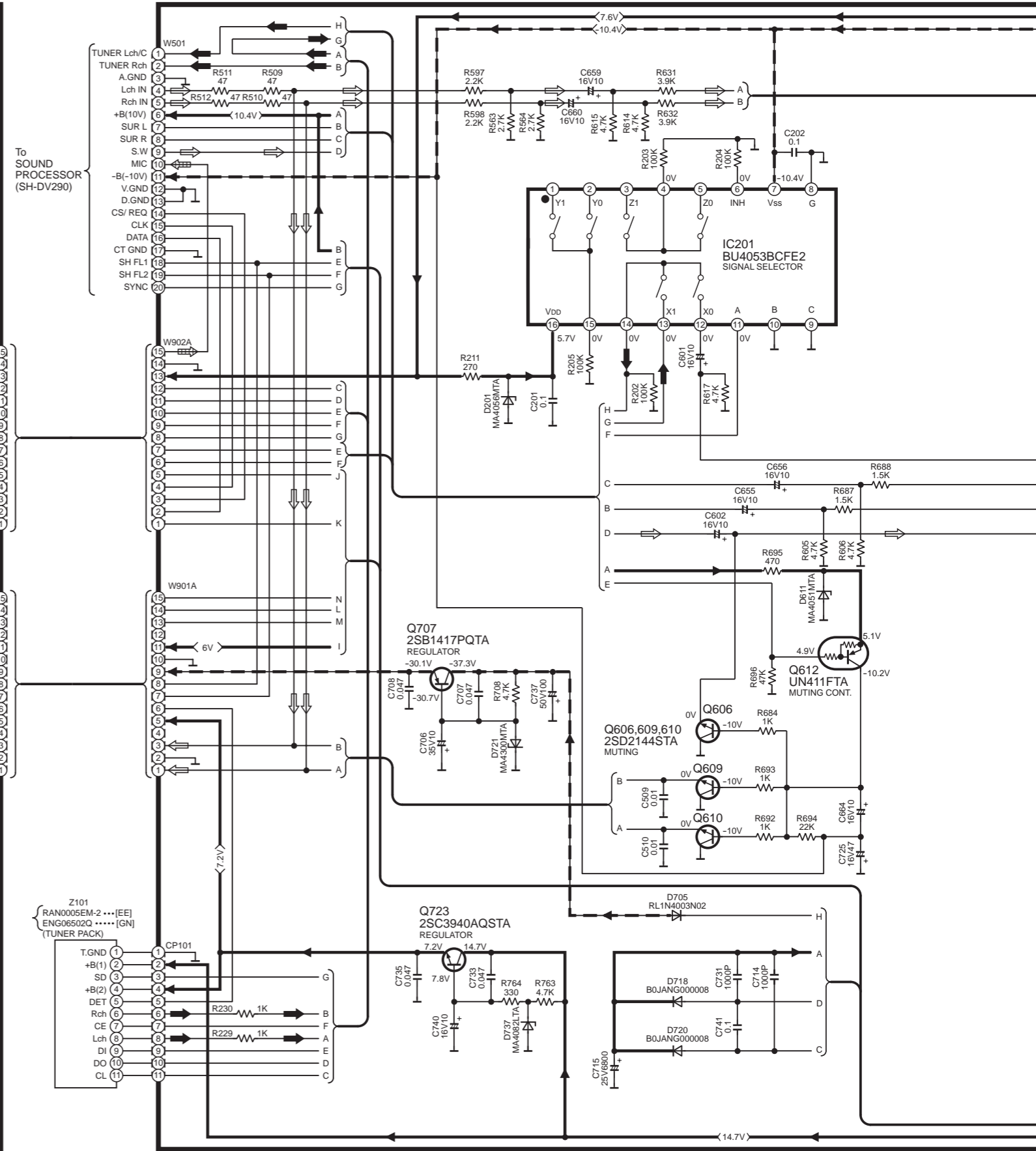
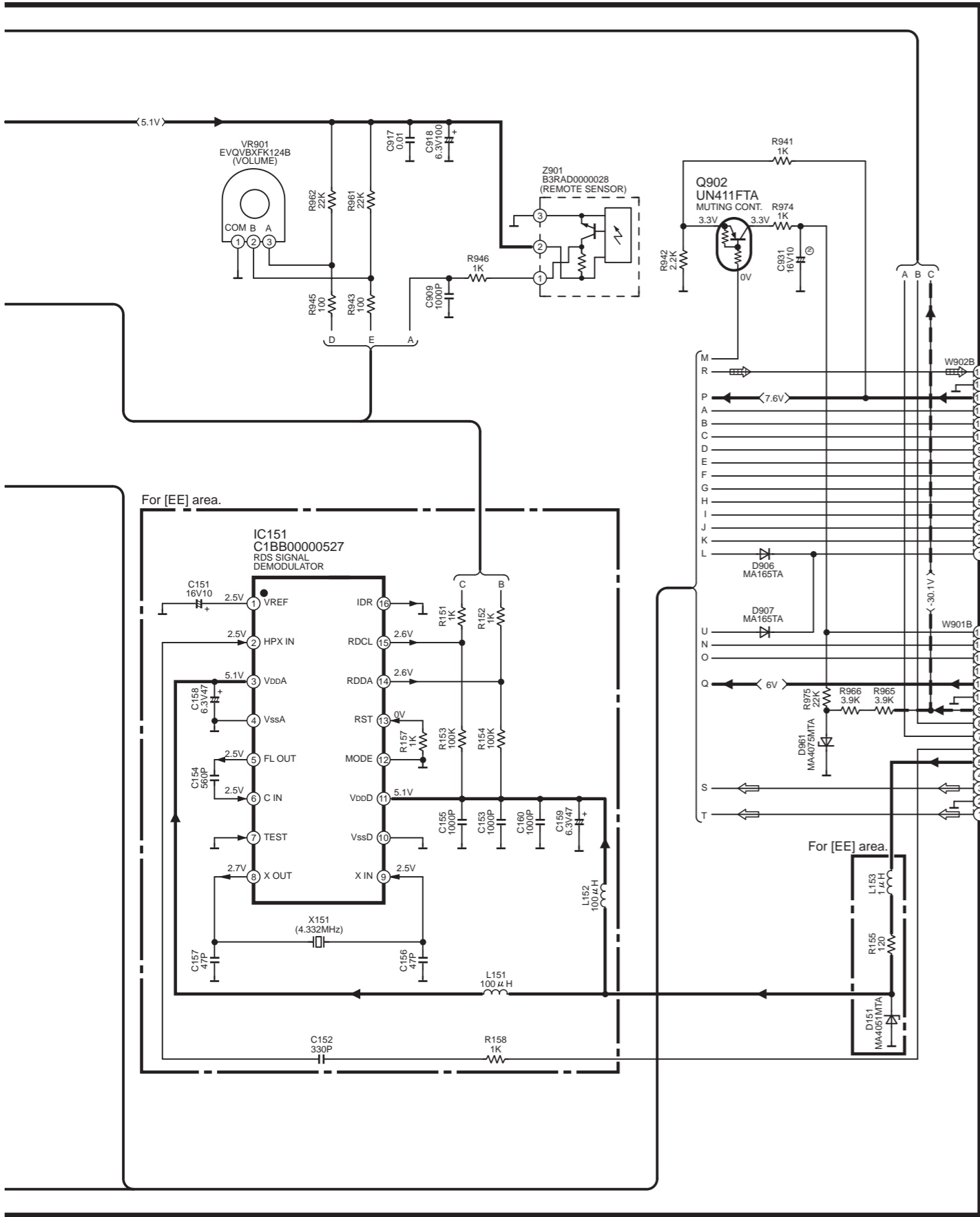

ORDER NO.AD0303068C8

Service Manual

Sound Processor



SH-DV290EG

Colour

(S)Silver Type

System: SC-DV290

Because of unique interconnecting cables,when a component requires servise,send or bring in the entire system.

Note: Refer to the service manual for Model No. SA-DV290E/EG/EB (ORDER NO.AD0303067C2) for information on "ACCESSORIES"and "PACKAGING".

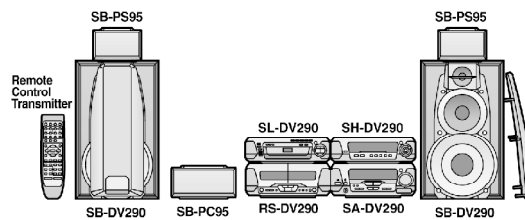

SPECIFICATIONS

Specification

■ EQ/SFP section

MANUAL GEQ

5-Band EQ

Center frequency 70/300/1 k/3.15 k/10 kHz
Level control ±2.0, 4.0, 6.0 dB

EQ/Space mode

4 modes HEAVY, CLEAR, SOFT, HALL

SUPER 3D AI EQ

3 modes AI EQ, SUPER 3D AI 1, SUPER 3D AI 2

■ Pre-amplifier section

Input sensitivity/impedance

VCR (EXT) 250 mV/15 k Ω
VDP (AUX) 250 mV/15 k Ω

Output level

VCR REC OUT 150 mV/1.5 k Ω

■ DOLBY PRO LOGIC section

PRO LOGIC mode SURROUND
CENTER mode NORMAL
DELAY TIME 20 ms (Fixed)

■ AV SURROUND section

AV surround mode

SUPER SURROUND (MUSIC, MOVIE)

■ DSP CONTROL section

DSP control mode SUPER SOUND EQ
 CENTER FOCUS
 VIRTUAL REAR SURROUND
 MULTI REAR SURROUND
 SEAT POSITION

■ Spectrum analyzer section

Display mode NORMAL, PEAKHOLD, AURORA

■ General

Dimensions (W×H×D) 293×89×270 mm
Mass 1.5 kg
Power Supply DC±10V/ -25V, AC4.6V
Power Consumption 7W

Notes 1.Design and specifications are subject to
 change without notice.
 2.Dimensions and weight are approximate.
 3.Total harmonic distortion is measured by the
 digital spectrum analyzer.

■ System/SC-DV290

Sound processor: SH-DV290, DVD/ Video CD/ CD
changer: SL-DV290, Tuner/ Amplifier: SA-DV290 ,
Cassette Deck: RS-DV290, Speakers: Front* (SB-
DV290),Center* (SB-PC95),Surround* (SB-PS95)
(*Made in MAES.)

Manufactured under license from Dolby Laboratories. /
“Dolby”, “Pro Logic” and the double-D symbol are
trademarks of Dolby Laboratories.

⚠ WARNING

This service information is designed for experienced repair technicians only and is not designed for use by the general public. It does not contain warnings or cautions to advise non-technical individuals of potential dangers in attempting to service a product. Products powered by electricity should be serviced or repaired only by experienced professional technicians. Any attempt to service or repair the product or products dealt with in this service information by anyone else could result in serious injury or death.

Technics

1. Before Repair

This equipment (SH-DV290), which is the component of the system, is supplied with power from the amplifier (SA-DV290). When repairing this equipment or checking operation of the system, be sure to connect the amplifier with it.

Power supply and operation check in the state of it as a single equipment are impracticable.

2. Operating Instructions

3. Operation Checks and Component Replacement Procedures

- This section describes procedures for checking the operation of the major printed circuit boards and replacing the main components.
- For reassembly after operation checks or replacement, reverse the respective procedures. Special reassembly procedures are described only when required.

3.1. Checking for the FL P.C.B.

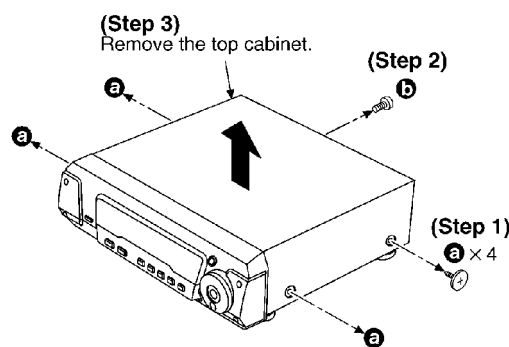

(Step 4)
Release the 6 claws, and then
remove the front panel ass'y.

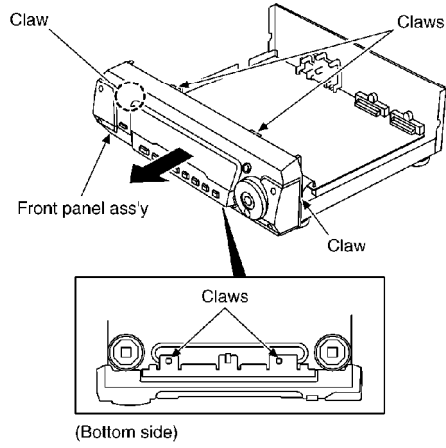

(Step 5)
Release the 5 claws, and then
remove the FL P.C.B..

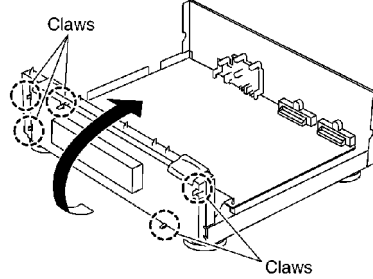

- Check the FL P.C.B. as shown below.

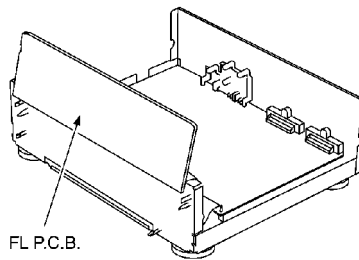

3.2. Checking for the main P.C.B.

- Follow the (Step 1) - (Step 3) of item 3.1.

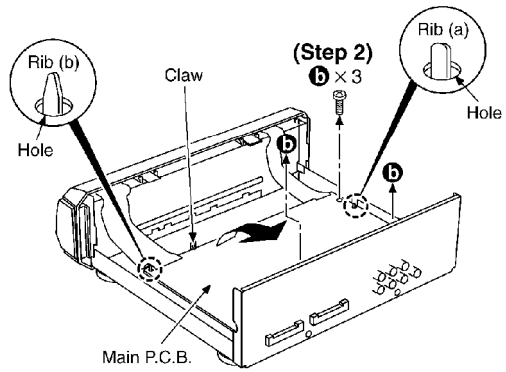
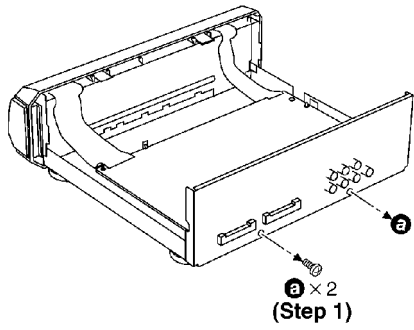

(Step 3)
Release the claw, and then lift up the main P.C.B..
(Lift up the main P.C.B. until the rib (a) and rib (b) are released from the hole of main P.C.B..)

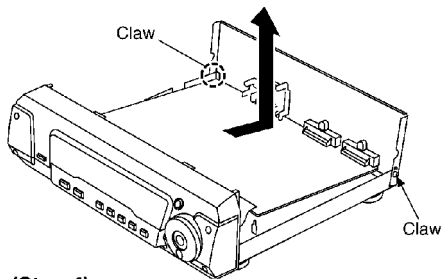

(Step 4)
Release the 2 claws, and then remove the main P.C.B. in the direction of arrow.

- Check the main P.C.B. as shown below.

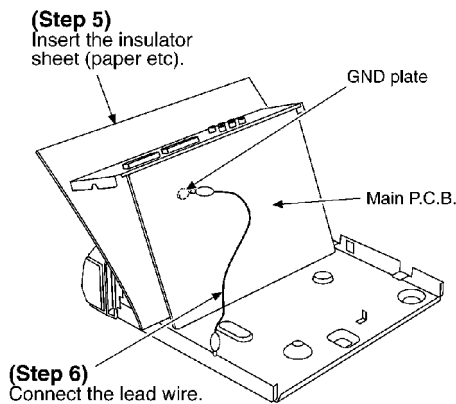

4. Wiring Connection Diagram

5. Block Diagram

6. To Supply Power Source

This unit is designed to operate on power supplied from system connected.

When a component requires service, use the system connections to supply power source.

For system connections. (Refer to Fig. 1)

Fig. 1

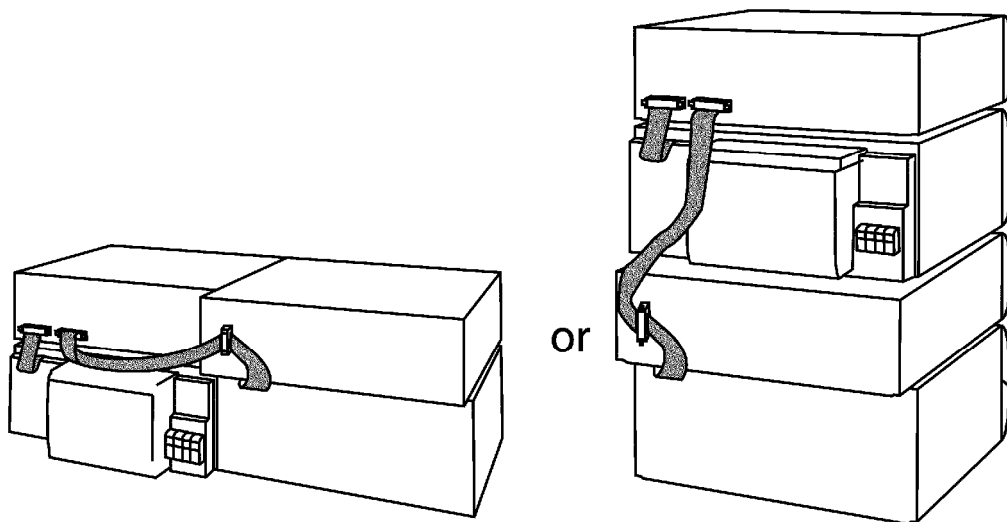

7. Schematic Diagram Notes

7.1. Type Illustrations of IC's, Transistors and Diodes

7.2. Schematic Diagram Notes

- This schematic diagram may be modified at any time with development of new technology.

Notes:

- S601: Display mode (DISPLAY MODE) switch.
- S602: DOLBY PRO LOGIC (DOLBY PRO LOGIC, OFF/ ON) switch.
- S603: Super surround (SUPER SURROUND) switch .
- S604: Super sound EQ (SUPER SOUND EQ) switch .
- S605: Center focus (CENTER FOCUS) switch.
- S606: Virtual rear surround (VIRTUAL REAR SURROUND) switch.
- S607: Multi rear surround (MULTI REAR SURROUND) switch.
- S608: Jog control (▶) switch.
- S609: Jog control (▲) switch.
- S610: Jog control (◀) switch.
- S611: Jog control (▼) switch.
- S612: Super 3D AI EQ (SUPER 3D AI EQ) switch.
- S613: Seat position (SEAT POSITION) switch.
- S614: Joystick (MULTI JOG) switch.
- Indicated voltage values are the standard values for the unit measured by the DC electronic circuit tester (high-impedance) with the chassis taken as standard. Therefore, there may exist some errors in the voltage values, depending on the internal impedance of the DC circuit tester. /

No mark: Power on

Important safety notice:

Components identified by  mark have special characteristics important for safety. Furthermore, special parts which have purpose of fire-retardant (resistors), high-quality sound (capacitors), low-noise (resistors), etc. are used. When replacing any of components, be sure to use only manufacturer's specified parts shown in the parts list.

Caution!

- IC and LSI are sensitive to static electricity.
- Secondary trouble can be prevented by taking care during repair.
- Cover the parts boxes made of plastics with aluminum foil.
- Ground the soldering iron.
- Put a conductive mat on the work table.
- Do not touch the legs of IC or LSI with the fingers directly.

Voltage and signal line

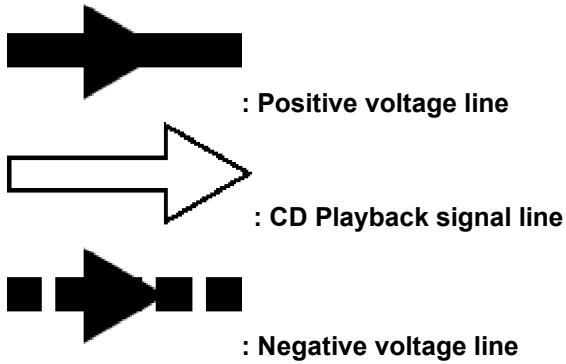

8. Schematic Diagram

9. Printed Circuit Board Diagram

10. Terminal Function of IC's

10.1. IC601(C2BBGF000425):System control/FL drive

Pin No.	Mark	I/O / Division	Function
1	KEY1	I	Operation key1 signal input terminal
2	KEY2	I	Operation key2 signal input terminal
3	SP IN	I	A/D signal input terminal from IC602
4	SP A	O	Band select signal output terminal for IC602
5	SP B	O	Band select signal output terminal for IC602
6	SP C	O	Band select signal output terminal for IC602
7	SA CS	I	Chip select signal input terminal
8	DSP RST	O	Reset signal output terminal for IC401
9	DSP CS	O	Chip select signal output terminal for IC401
10	DSP SNS	I	Sense signal input terminal from IC401
11	DSP ACK	I	Acknowledge signal input terminal from IC401
12	DSP CK	O	Clock signal output terminal for IC401

Pin No.	Mark	I/O / Division	Function
13	DSP DO	O	Data signal output terminal for IC401
14	DSP DI	I	Data signal input terminal for IC401
15	JOGA	I	JOG A signal input terminal
16	JOGB	I	JOG B signal input terminal
17	CNVSS	I	Connected to GND through resistor
18	RESET	I	System reset signal input terminal
19	NC	-	Not used, open
20	NC	-	Not used, open
21	VSS	-	GND terminal
22	XIN	I	Ceramic oscillator input terminal (f=4MHz)
23	XOUT	O	Ceramic oscillator output terminal (f=4MHz)
24	VCC	I	Power supply input terminal
25	NC	-	Not used, open
26	NC	-	Not used, open
27	LED CFO	O	ORANGE LED(CENTER FOCUS) signal output terminal
28	LED CFG	O	GREEN LED(CENTER FOCUS) signal output terminal
29	BR93 DATA	I	Data signal input terminal from EEPROM
30	BR93 CS	-	Not used, open
31	BR93 CK	-	Not used, open
32	SYNC	I	Power failure detect signal input terminal
33	SA REQ	O	Request signal output terminal for Tuner/Amplifier
34	SA CK	O	Serial communication signal output terminal for Tuner/Amplifier
35	SA DO	O	Serial communication signal output terminal for Tuner/Amplifier
36	SA DI	I	Serial communication signal input terminal from Tuner/Amplifier

Pin No.	Mark	I/O / Division	Function
37	LED SSS	O	LED(SUPER SURROUND)signal output terminal
38	LED DPL	O	LED(DOLBY PRO LOGIC) signal output terminal
39	LED SPO	O	ORANGE LED (SEAT POSITION) signal output terminal
40	LED SPG	O	GREEN LED (SEAT POSITION) signal output terminal
41	LED 3DO	O	ORANGE LED (3D ENHANCED SURROUND) signal output terminal
42	LED 3DG	O	GREEN LED (3D ENHANCED SURROUND) signal output terminal
43	LED MRO	O	ORANGE LED (MULTI REAR SURROUND) signal output terminal
44	LED MRG	O	GREEN LED (MULTI REAR SURROUND) signal output terminal
45	LED VRO	O	ORANGE LED (VIRTUAL REAR SURROUND) signal output terminal
46	LED VRG	O	GREEN LED (VIRTUAL REAR SURROUND) signal output terminal
47-80	P1-P34	O	Segment signal output terminal
81	---	-	Not used, open
82-88	7G-1G	O	Grid signal output terminal
89	VEE	I	Power supply input terminal
90	CD& DECK DI	I	Data signal input terminal (DVD and deck mechanism)
91	CD& DECK DO	O	Data signal output terminal (DVD and deck mechanism)
92	CD& DECK CK	I	Clock signal input terminal (DVD and deck mechanism)
93	NC	-	Not used, open

Pin No.	Mark	I/O / Division	Function
94	CD REQ	O	Serial data request signal output terminal for DVD
95	DECK REQ	O	Serial data request signal output terminal for deck mechanism
96	CD& DECK CS	I	Chip select signal input terminal (DVD and deck mechanism)
97	AVSS	-	GND terminal
98	VREF	I	Reference voltage input terminal
99	REG IN0	I	Destination select signal input terminal
100	REG IN1	I	Destination select signal input terminal

11. Replacement Parts List

Note:

***Important safety notice:**

Components identified by  mark have special characteristics important for safety.

Furthermore, special parts which have purposes of fireretardant (resistors), high-quality sound (capacitors), lownoise (resistors), etc. are used.

When replacing any of components, be sure to use only manufacture's specified parts shown in the parts list.

***The markings (RTL) indicate the retention time is limited for this items. After the discontinuation of this assemblies in production, it will no longer be available.**

***Capacity values are in microfarads (uF) unless specified otherwise, P=Pico-farads (pF) F=Farads (F)**

***Resistance values are in ohms, unless specified otherwise, 1K= 1,000 (OHM), 1M=1,000K (OHM)**

***All parts are supplied by SPC.**

Ref. No.	Part No.	Part Name & Description	Pcs	Remarks
<u>1</u>	RKA0105-K	RUBBER	4	
<u>2</u>	RKA0106-N	FOOT RING	4	
<u>3</u>	RYP1176-S	FRONT PANEL ASS'Y	1	
<u>3-1</u>	RGB0025-A	TECHNICS BADGE	1	
<u>3-2</u>	RKW0576A-1V	FL WINDOW	1	
<u>3-3</u>	RGK1242-S	JOG RING ORNAMENT	1	
<u>3-4</u>	RGW0344-S1	JOG KNOB	1	
<u>3-5</u>	RGW0345-S	JOY KNOB	1	
<u>3-6</u>	RMB0594	JOY SPRING	1	
<u>3-7</u>	RMQ0882	JOY LEVER	1	
<u>3-8</u>	RMQ0883	JOY SUPPORT	1	
<u>3-9</u>	RMQ0884	JOY BASE	1	
<u>3-10</u>	RMQ0885	JOG KNOB BASE	1	
<u>3-11</u>	RMX0169	RING	1	
4	XTB3+8JFZ	SCREW	11	
5	RHD30007-1S	SCREW	4	
6	RKM0400-S1	TOP CABINET	1	
7	RMN0526	FL HOLDER	1	
8	REZ1299	WIRE ASS'Y	1	
9	RGR0285E-F	REAR PANEL	1	
C109	ECA1CAK100XB	16V 10U	1	
C131-36	ECUV1H101KCV	50V 100P	6	ECJ1VC1H101K
C143	ECUV1H101KCV	50V 100P	1	ECJ1VC1H101K
C201-04	ECBT1H331KB3	50V 330P	4	
C205,06	ECBT1H330J5	50V 33P	2	F1D1H330A006
C207,08	ECEA1HKA4R7	50V 4.7U	2	
C209,10	ECBT1C103MS5	16V 0.01U	2	F1D1C103A004
C211,12	ECBT1H104KB5	50V 0.1U	2	F1D1H1040002
C213-15	ECBT1H470J3	50V 47P	3	
C216,17	ECBT1C103MS5	16V 0.01U	2	F1D1C103A004
C221,22	ECBA1H101KB5	50V 100P	2	
C223,24	ECA1CAK100XB	16V 10U	2	
C225-33	ECBA1H101KB5	50V 100P	9	
C288,89	ECA1CAK100XB	16V 10U	2	
C301-04	ECEA1HKA4R7	50V 4.7U	4	
C305,06	ECBA1H101KB5	50V 100P	2	
C307,08	ECBT1H100JC5	50V 10P	2	F1D1H100A015
C309,10	ECBT1C103MS5	16V 0.01U	2	F1D1C103A004
C311	ECA1CAK100XB	16V 10U	1	
C312	ECA1CAK220XB	16V 22U	1	
C313,14	ECA1CAK100XB	16V 10U	2	
C315,16	ECBA1H101KB5	50V 100P	2	
C317	ECBT1C562KR5	16V 5600P	1	F1D1C562A010
C318	ECBT1H270J5	50V 27P	1	ECBT1H270J3
C319-22	ECA1CAK100XB	16V 10U	4	
C323,24	ECBT1C103MS5	16V 0.01U	2	F1D1C103A004
C327	ECBT1H333KB5	50V 0.033U	1	ECBT1H333KB3
C328,29	ECA1CAK220XB	16V 22U	2	
C343,44	ECA1CAK100XB	16V 10U	2	
C345,46	ECBA1H101KB5	50V 100P	2	
C347,48	ECBT1H220J5	50V 22P	2	F1D1H220A006
C349,50	ECA1CAK100XB	16V 10U	2	

Ref. No.	Part No.	Part Name & Description	Pcs	Remarks
C351,52	ECBT1C103MS5	16V 0.01U	2	F1D1C103A004
C354	ECA1CAK100XB	16V 10U	1	
C356	ECA1CAK100XB	16V 10U	1	
C401	ECJ1VB1E223K	25V 0.022U	1	
C402,03	ECUVNH103KBV	50V 0.01U	2	F1H1H103A748
C404	ECA0JAK470XH	6.3V 47U	1	
C501	ECBT1C103MS5	16V 0.01U	1	F1D1C103A004
C502	ECBT1H331KB3	50V 330P	1	
C503,04	ECBA1H101KB5	50V 100P	2	
C505	ECBT1C103MS5	16V 0.01U	1	F1D1C103A004
C506	ECA1CAK330XB	16V 33U	1	
C507	RCE1HKAR47BG	50V 0.47U	1	F2A1HR47A015
C508	ECA1CAK100XB	16V 10U	1	
C509,10	ECA1CAK220XB	16V 22U	2	
C511	ECA1CAK100XB	16V 10U	1	
C512	ECA1CAK330XB	16V 33U	1	
C601	ECBT1H104KB5	50V 0.1U	1	F1D1H1040002
C602	ECA0JM102	6.3V 1000U	1	
C603,04	ECBT1H102KB3	50V 1000P	2	
C605	ECA1VAK330XB	35V 33U	1	
C606,07	ECBT1H471KB3	50V 470P	2	
C608	ECBT1H221KB3	50V 220P	1	
C609,10	ECBT1C103MS5	16V 0.01U	2	F1D1C103A004
C611	ECA1HAK3R3XB	50V 3.3U	1	
C612,13	F2A1C220A034	16V 22U	2	
C614	ECA1CAK100XB	16V 10U	1	
C615	ECA1VAK330XB	35V 33U	1	
C616	ECEA1VKS330Q	35V 33U	1	
C618,19	ECBT1C103MS5	16V 0.01U	2	F1D1C103A004
C620,21	ECA1HAK0R1XB	50V 0.1U	2	
C622,23	ECBT1H104KB5	50V 0.1U	2	F1D1H1040002
C624	ECBT1C103MS5	16V 0.01U	1	F1D1C103A004
C625	ECA0JAK101XB	6.3V 100U	1	
C626	ECBT1H473KB5	50V 0.047U	1	F1D1H473A012
C627,28	F2A1C220A034	16V 22U	2	
C753,54	ECBT1C103MS5	16V 0.01U	2	F1D1C103A004
C761-63	ECBT1C103MS5	16V 0.01U	3	F1D1C103A004
C764	ECA1AAK221XH	10V 220U	1	
C765	ECBT1C103MS5	16V 0.01U	1	F1D1C103A004
C766	ECA1CAK100XB	16V 10U	1	
C767	ECBT1C103MS5	16V 0.01U	1	F1D1C103A004
C768	ECA1CAK100XB	16V 10U	1	
C769	ECBT1C103MS5	16V 0.01U	1	F1D1C103A004
C770	ECA1CAK100XB	16V 10U	1	
C771,72	ECBT1C103MS5	16V 0.01U	2	F1D1C103A004
C773	ECA1AAK221XH	10V 220U	1	
C774	ECA1CAM221XB	16V 220U	1	
C801	ECJ1VC1H120J	50V 12P	1	
C802	ECJ1VC1H050C	50V 5P	1	
C803	ECJ1VB1H102K	50V 1000P	1	
C804	ECJ1VB1C104K	16V 0.1U	1	
C805	ECJ1VB0J105K	6.3V 1U	1	
C806,07	ECJ1VB1H222K	50V 2200P	2	
C808-10	ECUVNH103KBV	50V 0.01U	3	F1H1H103A748

Ref. No.	Part No.	Part Name & Description	Pcs	Remarks
C811	ECJ1VB1E223K	25V 0.022U	1	
C812	ECJ1VB1C104K	16V 0.1U	1	
C813	ECUVNH103KBV	50V 0.01U	1	F1H1H103A748
C814	ECJ1VB0J105K	6.3V 1U	1	
C815	ECJ1VB1E223K	25V 0.022U	1	
C816	ECJ1VB1C104K	16V 0.1U	1	
C818,19	ECJ1VB1H681K	50V 680P	2	
C820,21	ECEA1HKA4R7	50V 4.7U	2	
C822	ECA0JAK470XH	6.3V 47U	1	
C823	EEAFC0J101B	6.3V 100U	1	
C824	ECA0JAK470XH	6.3V 47U	1	
C825-32	ECEA1HKA4R7	50V 4.7U	8	
C833-35	ECA0JAK470XH	6.3V 47U	3	
C836,37	ECA1CAK100XB	16V 10U	2	
C838,39	ECA1HAK010XI	50V 1U	2	
C851,52	ECJ1VB1H222K	50V 2200P	2	
C853,54	ECA1CAK100XB	16V 10U	2	
C855,56	ECEA1HKA4R7	50V 4.7U	2	
C857,58	ECJ1VB1C104K	16V 0.1U	2	
C859	ECEA1HKA4R7	50V 4.7U	1	
C860	ECJ1VB1H222K	50V 2200P	1	
C861	ECJ1VB1H561K	50V 560P	1	
C862	ECUV1H471KVB	50V 470P	1	F1H1H471A013
C863,64	ECA0JAK470XH	6.3V 47U	2	
C865	ECJ1VB0J105K	6.3V 1U	1	
C866-68	ECA1HAK010XI	50V 1U	3	
C869	ECUVNH103KBV	50V 0.01U	1	F1H1H103A748
C870	EEAFC0J101B	6.3V 100U	1	
C871,72	ECJ1VB1H222K	50V 2200P	2	
C873-76	ECA1HAK010XI	50V 1U	4	
C877,78	ECUVNH103KBV	50V 0.01U	2	F1H1H103A748
C879,80	ECJ1VB1H222K	50V 2200P	2	
C881,82	ECA1HAK010XI	50V 1U	2	
C883	ECA0JAK470XH	6.3V 47U	1	
C884	ECJ1VB1H222K	50V 2200P	1	
C886	EEAFC0J101B	6.3V 100U	1	
C887,88	ECA0JAK470XH	6.3V 47U	2	
C891	ECUVNH103KBV	50V 0.01U	1	F1H1H103A748
C892	ECA0JAK470XH	6.3V 47U	1	
C893	ECUVNH103KBV	50V 0.01U	1	F1H1H103A748
C894-97	ECJ1VB1E223K	25V 0.022U	4	
C898	EEAFC0J101B	6.3V 100U	1	
C899	ECA0JAK470XH	6.3V 47U	1	
CN201	RJT065A20	SYSTEM CONNECTOR(20P)	1	K1FA220B0007
CN202	RJT065K20	SYSTEM CONNECTOR(20P)	1	K1FA220B0006
D201	MAZ40560MF	DIODE	1	
D203	MA165TA5	DIODE	1	MA2C16500E
D204	MA719	DIODE	1	MA2C719
D301	MA700	DIODE	1	MA2C700
D302	MA165TA5	DIODE	1	MA2C16500E
D304,05	MA719	DIODE	2	MA2C719
D601-04	1SS291TA	DIODE	4	

Ref. No.	Part No.	Part Name & Description	Pcs	Remarks
D605-10	MA165TA5	DIODE	6	MA2C16500E
D611,12	LNJ301MPUJAD	LED	2	
D613-17	B3AHA0000012	LED	5	
D653	MA165TA5	DIODE	1	MA2C16500E
D761	MA4082LTA	DIODE	1	MAZ40820LF
D762	B0AAMM000009	DIODE	1	
D763-66	MA165TA5	DIODE	4	MA2C16500E
D767	MA4051M	DIODE	1	MAZ40510M
D770	MA4062H	DIODE	1	MAZ40620H
D771	MA4051-L	DIODE	1	MAZ40510L
D772	MA165TA5	DIODE	1	MA2C16500E
FL601	A2BD00000041	FL DISPLAY TUBE	1	
IC201	NJU7313AMT2	IC	1	C0JZAS000002
IC202	NJM4558MTE1	IC	1	C0ABBB000109
IC203	C0JBAR000292	IC	1	
IC301	M5218AP	IC	1	C0AABB000055
IC302,03	NJM4558MTE1	IC	2	C0ABBB000109
IC401	C2BBFD000246	IC	1	
IC501	NJM4558MTE1	IC	1	C0ABBB000109
IC601	C2BBGF000425	IC	1	
IC602	M62457AFPE1	IC	1	C1BB00000486
IC801	C2HBZC000010	IC	1	
IC802	C2HBZC000008	IC	1	
JK101	SJF3068-7N	JACK,VDP(AUX)	1	K2HA102B0046
JK102	SJF3069-5N	JACK,VCR(EXT)IN/OUT	1	K2HA204B0083
JK103	SJFD7	JACK,SUB WOOFER OUT	1	K4BK01B00002
L101	RLBV252AV-Y	COIL	1	J0JBC0000019
L301,02	RLQA3R3JT1-Y	COIL	2	G0C3R3JA0019
L401	RLQB100JTD-D	COIL	1	G0C100JA0030
L502	RLBV252AV-Y	COIL	1	J0JBC0000019
L601	G0C100JA0019	COIL	1	
L801	J0JCC0000077	COIL	1	
L802	RLBV102V-Y	COIL	1	J0JBC0000014
L804	RLBV102V-Y	COIL	1	J0JBC0000014
L806	RLBV102V-Y	COIL	1	J0JBC0000014
L807	G0A200D00002	COIL	1	
L808	RLQB100JTD-D	COIL	1	G0C100JA0030
L811	RLBV102V-Y	COIL	1	J0JBC0000014
L814	G0A200D00002	COIL	1	
L821,22	RLBV252AV-Y	COIL	2	J0JBC0000019
PCB1	REP3073H-M	MAIN P.C.B. ASS'Y	1	[RTL]
Q301-04	2SD2144S	TRANSISTOR	4	
Q305,06	UN411FTA	TRANSISTOR	2	UNR411F00A
Q307-10	2SD2144S	TRANSISTOR	4	
Q313-16	2SD2144S	TRANSISTOR	4	
Q501,02	UN411FTA	TRANSISTOR	2	UNR411F00A
Q503-05	2SD2144S	TRANSISTOR	3	

Ref. No.	Part No.	Part Name & Description	Pcs	Remarks
Q506	UN411FTA	TRANSISTOR	1	UNR411F00A
Q507	2SD2144S	TRANSISTOR	1	
Q601	UN4211	TRANSISTOR	1	UNR4211
Q602-04	2SC3311A	TRANSISTOR	3	2SC3311AW
Q605,06	UN5211TX	TRANSISTOR	2	UNR521100L
Q761,62	2SD2137PQTA	TRANSISTOR	2	2SD21370PA
Q763	2SD592A	TRANSISTOR	1	2SD0592AW
Q764	2SB0621AHA	TRANSISTOR	1	
Q765	2SC3311A	TRANSISTOR	1	2SC3311AW
Q766	2SA1309ATA	TRANSISTOR	1	2SA1309AWA
Q767	2SC3311A	TRANSISTOR	1	2SC3311AW
Q768	2SC3940AQSTA	TRANSISTOR	1	2SC3940ARA
R101,02	ERDS2FJ104	1/4W 100K	2	
R103,04	ERDS2FJ102	1/4W 1K	2	
R105,06	ERDS2FJ123	1/4W 12K	2	
R107,08	ERDS2FJ332	1/4W 3.3K	2	
R111,12	ERDS2FJ332	1/4W 3.3K	2	
R113,14	ERDS2FJ123	1/4W 12K	2	
R127	ERDS2FJ104	1/4W 100K	1	
R128	ERDS2FJ102	1/4W 1K	1	
R129,30	ERDS2T0	1/4W 0	2	
R131	ERJ3GEY0R00V	1/16W 0	1	
R203,04	ERDS2FJ222	1/4W 2.2K	2	
R205,06	ERDS2FJ563	1/4W 56K	2	
R207,08	ERDS2FJ273	1/4W 27K	2	
R209,10	ERDS2FJ104	1/4W 100K	2	
R211-14	ERDS2FJ222	1/4W 2.2K	4	
R219	ERDS2FJ391	1/4W 390	1	
R220	ERDS2FJ104	1/4W 100K	1	
R221,22	ERDS2FJ221	1/4W 220	2	
R223,24	ERDS2FJ223	1/4W 22K	2	
R225,26	ERDS2FJ102	1/4W 1K	2	
R227,28	ERDS2TJ682	1/4W 6.8K	2	
R229,30	ERDS2FJ822	1/4W 8.2K	2	
R233-36	ERDS2FJ102	1/4W 1K	4	
R237,38	ERDS2FJ822	1/4W 8.2K	2	
R239	ERDS2FJ473	1/4W 47K	1	
R240	ERDS2FJ102	1/4W 1K	1	
R249,50	ERDS2FJ152	1/4W 1.5K	2	
R255,56	ERDS2FJ472	1/4W 4.7K	2	
R257,58	ERDS2FJ822	1/4W 8.2K	2	
R259,60	ERDS2T0	1/4W 0	2	
R284,85	ERDS2T0	1/4W 0	2	
R286,87	ERDS2FJ393	1/4W 39K	2	
R288-91	ERDS2T0	1/4W 0	4	
R295,96	ERDS2T0	1/4W 0	2	
R297,98	ERDS2FJ471	1/4W 470	2	
R303,04	ERDS2FJ223	1/4W 22K	2	
R305-08	ERDS2FJ102	1/4W 1K	4	
R309,10	ERDS2FJ561	1/4W 560	2	
R311	ERDS2FJ223	1/4W 22K	1	
R312	ERDS2FJ182	1/4W 1.8K	1	
R313,14	ERDS2TJ392	1/4W 3.9K	2	

Ref. No.	Part No.	Part Name & Description	Pcs	Remarks
R315,16	ERDS2FJ274	1/4W 270K	2	
R317	ERDS2FJ223	1/4W 22K	1	
R318	ERDS2FJ101	1/4W 100	1	
R319	ERDS2FJ154	1/4W 150K	1	
R322	ERJ3GEYJ822V	1/16W 8.2K	1	D0GB822JA002
R323,24	ERDS2FJ120	1/4W 12	2	
R325,26	ERDS2FJ102	1/4W 1K	2	
R327,28	ERDS2FJ561	1/4W 560	2	
R329	ERDS2FJ564	1/4W 560K	1	
R330	ERDS2TJ184T	1/4W 180K	1	
R331,32	ERDS2FJ222	1/4W 2.2K	2	
R333,34	ERDS2FJ563	1/4W 56K	2	
R335,36	ERDS2FJ102	1/4W 1K	2	
R337	ERDS2FJ391	1/4W 390	1	
R338	ERDS2FJ471	1/4W 470	1	
R345-47	ERDS2FJ102	1/4W 1K	3	
R348	ERDS2FJ222	1/4W 2.2K	1	
R349	ERDS2FJ123	1/4W 12K	1	
R350	ERDS2FJ103	1/4W 10K	1	
R351	ERDS2FJ224	1/4W 220K	1	
R352	ERDS2FJ103	1/4W 10K	1	
R353	ERDS2FJ224	1/4W 220K	1	
R354	ERDS2FJ562	1/4W 5.6K	1	
R357,58	ERDS2FJ223	1/4W 22K	2	
R359,60	ERDS2FJ821	1/4W 820	2	
R361,62	ERDS2TJ682	1/4W 6.8K	2	
R363,64	ERDS2FJ102	1/4W 1K	2	
R365,66	ERDS2TJ184T	1/4W 180K	2	
R367,68	ERDS2FJ471	1/4W 470	2	
R372	ERDS2T0	1/4W 0	1	
R374	ERDS2T0	1/4W 0	1	
R402	ERJ3GEYJ104	1/16W 100K	1	
R403	ERJ3GEYJ681V	1/16W 680	1	D0GB681JA002
R404	ERJ3GEYJ104	1/16W 100K	1	
R405-10	ERJ3GEYJ221V	1/16W 220	6	
R411	ERDS2FJ102	1/4W 1K	1	
R414,15	ERDS2FJ102	1/4W 1K	2	
R417	ERJ3GEYJ221V	1/16W 220	1	
R419	ERDS2FJ101	1/4W 100	1	
R420	ERDS2FJ102	1/4W 1K	1	
R421	ERDS2FJ101	1/4W 100	1	
R424	ERDS2FJ102	1/4W 1K	1	
R425,26	ERDS2FJ472	1/4W 4.7K	2	
R429	ERDS2FJ472	1/4W 4.7K	1	
R430,31	ERJ3GEYJ103V	1/16W 10K	2	D0GB103JA002
R432	ERDS2FJ102	1/4W 1K	1	
R501	ERDS2FJ152	1/4W 1.5K	1	
R502	ERDS2FJ102	1/4W 1K	1	
R503	ERDS2FJ122	1/4W 1.2K	1	
R504	ERDS2TJ124	1/4W 120K	1	
R505	ERDS2FJ102	1/4W 1K	1	
R506	ERDS2TJ272T	1/4W 2.7K	1	
R507	ERDS2TJ105	1/4W 1M	1	
R508	ERDS2FJ104	1/4W 100K	1	

Ref. No.	Part No.	Part Name & Description	Pcs	Remarks
R509	ERDS2FJ222	1/4W 2.2K	1	
R510	ERDS2FJ104	1/4W 100K	1	
R511	ERDS2TJ105	1/4W 1M	1	
R512	ERDS2FJ154	1/4W 150K	1	
R513	ERDS2FJ102	1/4W 1K	1	
R514	ERDS2FJ101	1/4W 100	1	
R515	ERDS2FJ223	1/4W 22K	1	
R517	ERDS2FJ821	1/4W 820	1	
R518	ERDS2FJ222	1/4W 2.2K	1	
R519	ERDS2FJ154	1/4W 150K	1	
R520	ERDS2FJ122	1/4W 1.2K	1	
R601-03	ERDS2FJ102	1/4W 1K	3	
R604,05	ERDS2FJ103	1/4W 10K	2	
R606	ERDS2FJ102	1/4W 1K	1	
R607,08	ERDS2FJ221	1/4W 220	2	
R609	ERDS2FJ222	1/4W 2.2K	1	
R610	ERDS2FJ332	1/4W 3.3K	1	
R611	ERDS2FJ101	1/4W 100	1	
R612	ERDS2FJ102	1/4W 1K	1	
R613	ERDS2FJ562	1/4W 5.6K	1	
R614-17	ERDS2FJ102	1/4W 1K	4	
R618	ERDS2FJ104	1/4W 100K	1	
R619	ERDS2FJ681	1/4W 680	1	
R622,23	ERDS2FJ104	1/4W 100K	2	
R624-29	ERDS2TJ181	1/4W 180	6	
R631	ERDS2FJ821	1/4W 820	1	
R632	ERDS2FJ102	1/4W 1K	1	
R633	ERDS2FJ122	1/4W 1.2K	1	
R634	ERDS2FJ152	1/4W 1.5K	1	
R635	ERDS2FJ182	1/4W 1.8K	1	
R636	ERDS2FJ222	1/4W 2.2K	1	
R637	ERDS2FJ821	1/4W 820	1	
R638	ERDS2FJ102	1/4W 1K	1	
R639	ERDS2FJ122	1/4W 1.2K	1	
R640	ERDS2FJ152	1/4W 1.5K	1	
R641	ERDS2FJ182	1/4W 1.8K	1	
R642	ERDS2FJ222	1/4W 2.2K	1	
R647	ERDS2FJ223	1/4W 22K	1	
R648-50	ERDS2FJ104	1/4W 100K	3	
R651	ERDS2FJ102	1/4W 1K	1	
R652,53	ERDS2FJ472	1/4W 4.7K	2	
R654-56	ERDS2FJ103	1/4W 10K	3	
R657	ERDS2FJ473	1/4W 47K	1	
R658,59	ERDS2FJ472	1/4W 4.7K	2	
R660	ERDS2FJ473	1/4W 47K	1	
R661	ERDS2FJ223	1/4W 22K	1	
R662	ERDS2FJ102	1/4W 1K	1	
R663,64	ERDS2FJ331	1/4W 330	2	
R665-67	ERDS2FJ473	1/4W 47K	3	
R668	ERDS2FJ222	1/4W 2.2K	1	
R671-80	ERJ6GEYJ104V	1/10W 100K	10	
R681	ERJ3GEYJ222V	1/16W 2.2K	1	
R682	ERJ3GEY0R00V	1/16W 0	1	
R686	ERJ3GEY0R00V	1/16W 0	1	

Ref. No.	Part No.	Part Name & Description	Pcs	Remarks
R691,92	ERDS2FJ221	1/4W 220	2	
R716	ERDS2FJ821	1/4W 820	1	
R761,62	ERDS2FJ2R2	1/4W 2.2	2	
R763	ERQ16NKWR33E	1/6W 0.33	1	
R764	ERDS2FJ821	1/4W 820	1	
R765	ERDS2FJ221	1/4W 220	1	
R766	ERDS2FJ182	1/4W 1.8K	1	
R767	ERDS2FJ102	1/4W 1K	1	
R768,69	ERDS2FJ122	1/4W 1.2K	2	
R770	ERD2FCJ4R7	1/4W 4.7	1	
R771	ERDS2FJ102	1/4W 1K	1	
R772	ERDS2FJ122	1/4W 1.2K	1	
R773	ERDS2FJ102	1/4W 1K	1	
R774	ERDS2FJ221	1/4W 220	1	
R801	ERJ3GEYJ221V	1/16W 220	1	
R802	ERJ3GEYJ105V	1/16W 1M	1	
R803	ERJ3GEYJ101	1/16W 100	1	D0GB101JA002
R804-07	ERJ3GEYJ271V	1/16W 270	4	
R808-10	ERJ3GEYJ331V	1/16W 330	3	
R811	ERJ3GEYJ472V	1/16W 4.7K	1	
R812	ERJ3GEYJ331V	1/16W 330	1	
R813	ERJ3GEYJ472V	1/16W 4.7K	1	
R814	ERJ3GEYJ104	1/16W 100K	1	
R815-20	ERJ3GEYJ102V	1/16W 1K	6	
R821	ERJ3GEYJ331V	1/16W 330	1	
R823	ERJ3GEYJ331V	1/16W 330	1	
R824,25	ERDS2TJ823	1/4W 82K	2	
R827	ERJ3GEY0R00V	1/16W 0	1	
R829	ERJ3GEYJ222V	1/16W 2.2K	1	
R830	ERJ3GEYJ472V	1/16W 4.7K	1	
R833,34	ERJ3GEYJ223V	1/16W 22K	2	D0GB223JA002
R835,36	ERJ3GEYJ152V	1/16W 1.5K	2	
R851,52	ERJ3GEYJ102V	1/16W 1K	2	
R854	ERJ3GEYJ183V	1/16W 18K	1	D0GB183JA002
R855	ERJ3GEYJ393V	1/16W 39K	1	D0GB393JA002
R856	ERJ3GEY0R00V	1/16W 0	1	
R857-59	ERJ3GEYJ103V	1/16W 10K	3	D0GB103JA002
R860	ERJ3GEYJ560V	1/16W 56	1	
R861	ERJ3GEYJ104	1/16W 100K	1	
R863,64	MCR03PZHJ561	1/16W 560	2	
R866	ERJ3GEYJ223V	1/16W 22K	1	D0GB223JA002
R867,68	MCR03PZHJ561	1/16W 560	2	
R869-72	ERJ3GEYJ271V	1/16W 270	4	
R873,74	ERJ3GEYJ331V	1/16W 330	2	
R875,76	ERJ3GEYJ271V	1/16W 270	2	
R877,78	ERJ3GEYJ223V	1/16W 22K	2	D0GB223JA002
R879,80	ERJ3GEYJ222V	1/16W 2.2K	2	
R881	ERJ3GEYJ101	1/16W 100	1	D0GB101JA002
R882	ERJ3GEYJ105V	1/16W 1M	1	
R888,89	ERJ3GEYJ331V	1/16W 330	2	
R890	ERJ3GEYJ103V	1/16W 10K	1	D0GB103JA002
R891,92	ERJ3GEYJ222V	1/16W 2.2K	2	
R898	ERJ3GEY0R00V	1/16W 0	1	
R900	ERJ3GEY0R00V	1/16W 0	1	

Ref. No.	Part No.	Part Name & Description	Pcs	Remarks
R903	ERDS2TJ124	1/4W 120K	1	
S601-07	EVQ11G05R	SW,PUSH	7	
S608-11	EVQ11G07K	SW,JOY STICK	4	
S612,13	EVQ11G05R	SW,PUSH	2	
S614	ESE24SV7	SW,MULTI JOG	1	
X401	RSXY8M00D01T	OSCILLATOR	1	H2B800400005
X601	H2B400400013	OSCILLATOR	1	
X801	RSXZ36M8M01T	OSCILLATOR	1	

12. Cabinet Parts Location

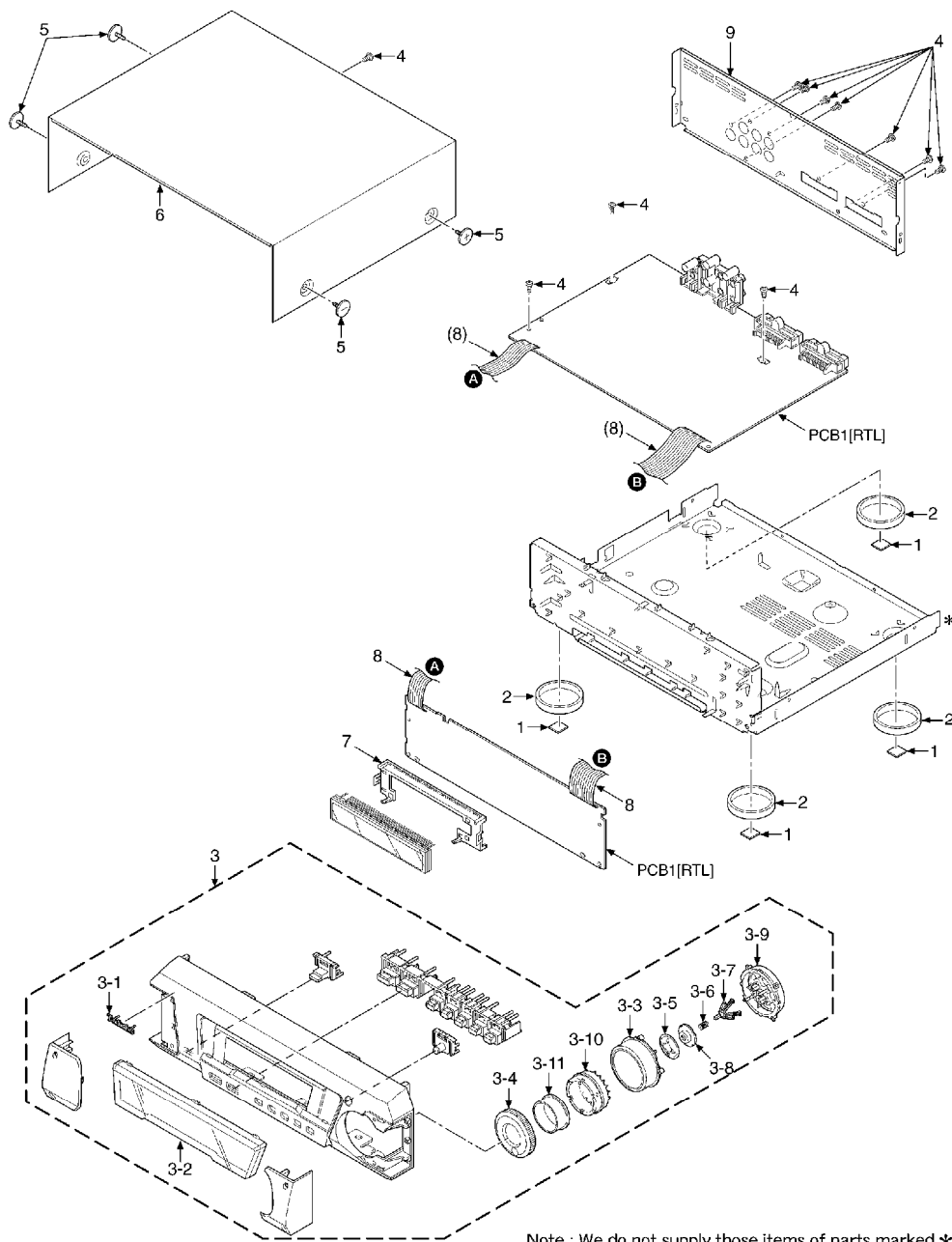

Note : We do not supply those items of parts marked * .
This "PCB1" is a combination PCB.

13. Schematic Diagram for printing with A4 size K0304YH/HM

A OPERATION P.C.B.

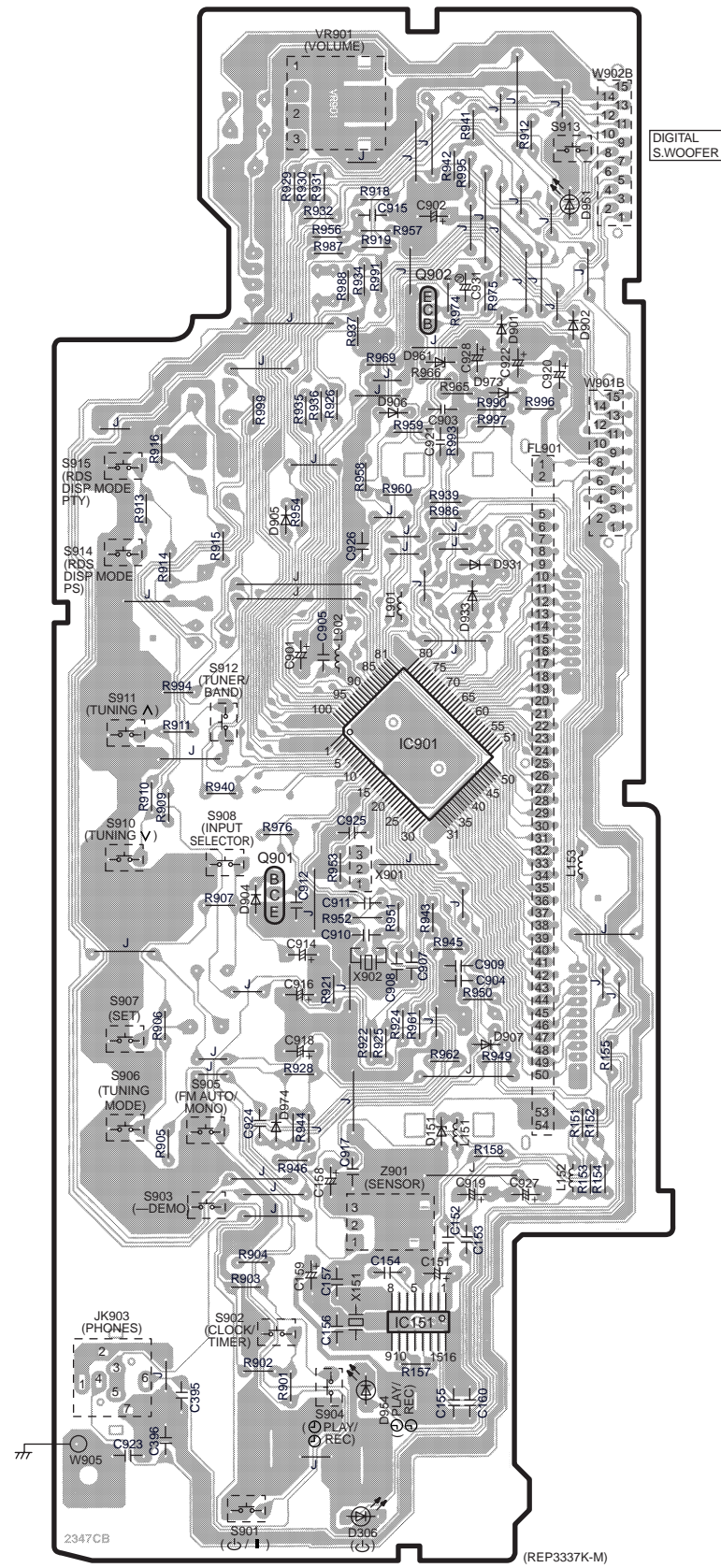

B MAIN P.C.B.

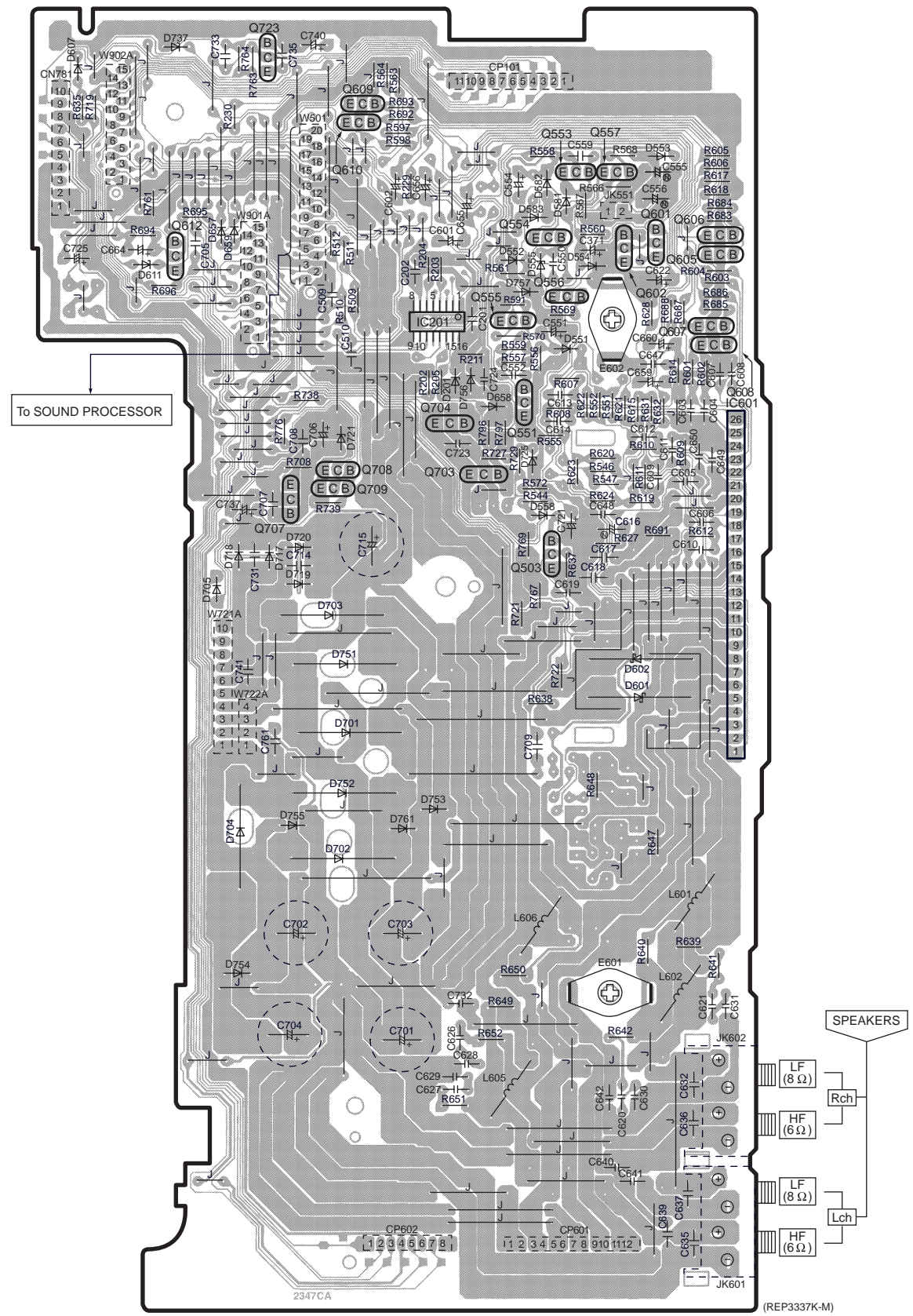

A OPERATION CIRCUIT

→ : POSITIVE VOLTAGE LINE - - - - - : NEGATIVE VOLTAGE LINE ⇨ : AUDIO SIGNAL LINE

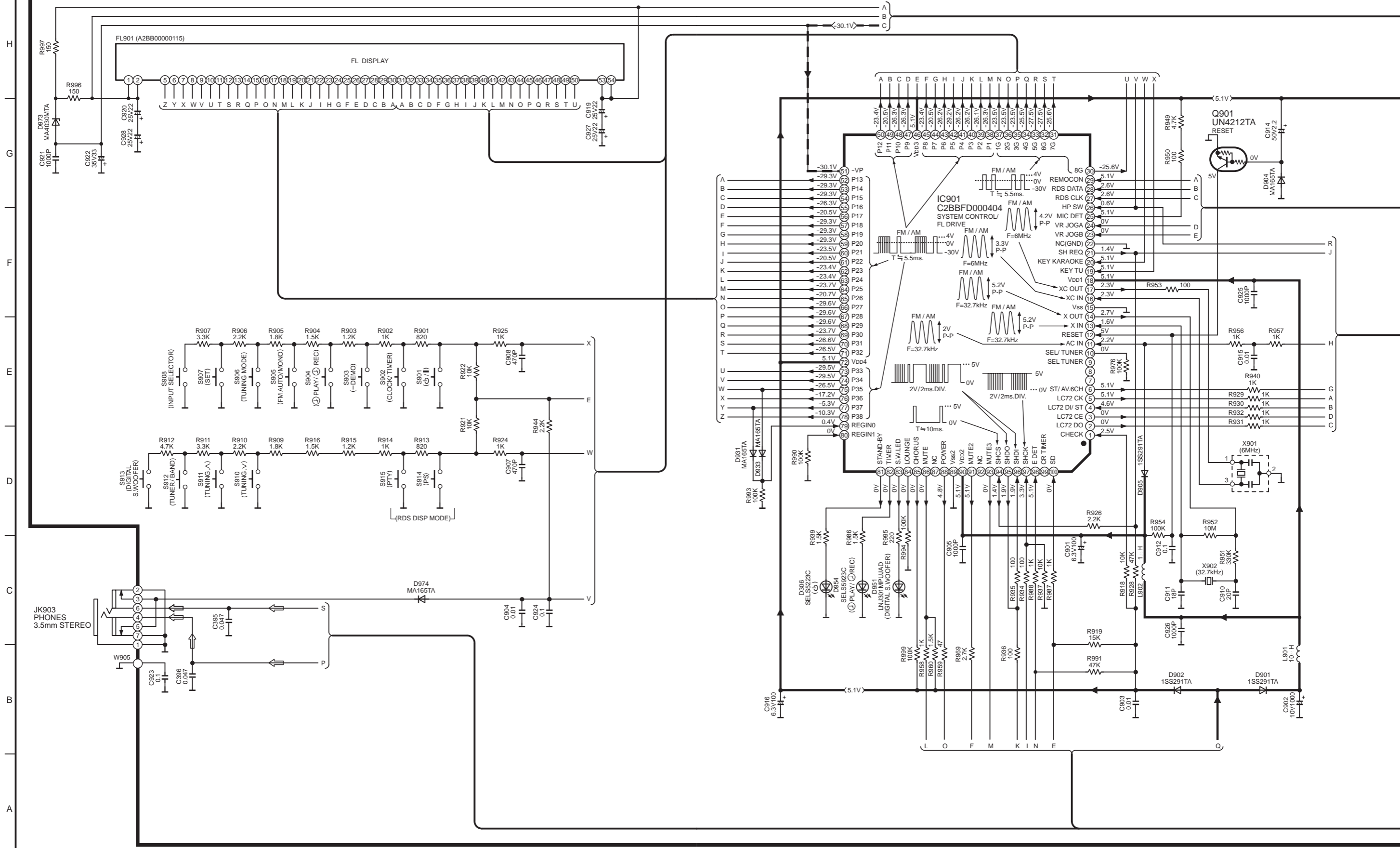

A OPERATION CIRCUIT

- - - : NEGATIVE VOLTAGE LINE : AUDIO SIGNAL LINE
 ——— : POSITIVE VOLTAGE LINE : TUNER SIGNAL LINE

B MAIN CIRCUIT

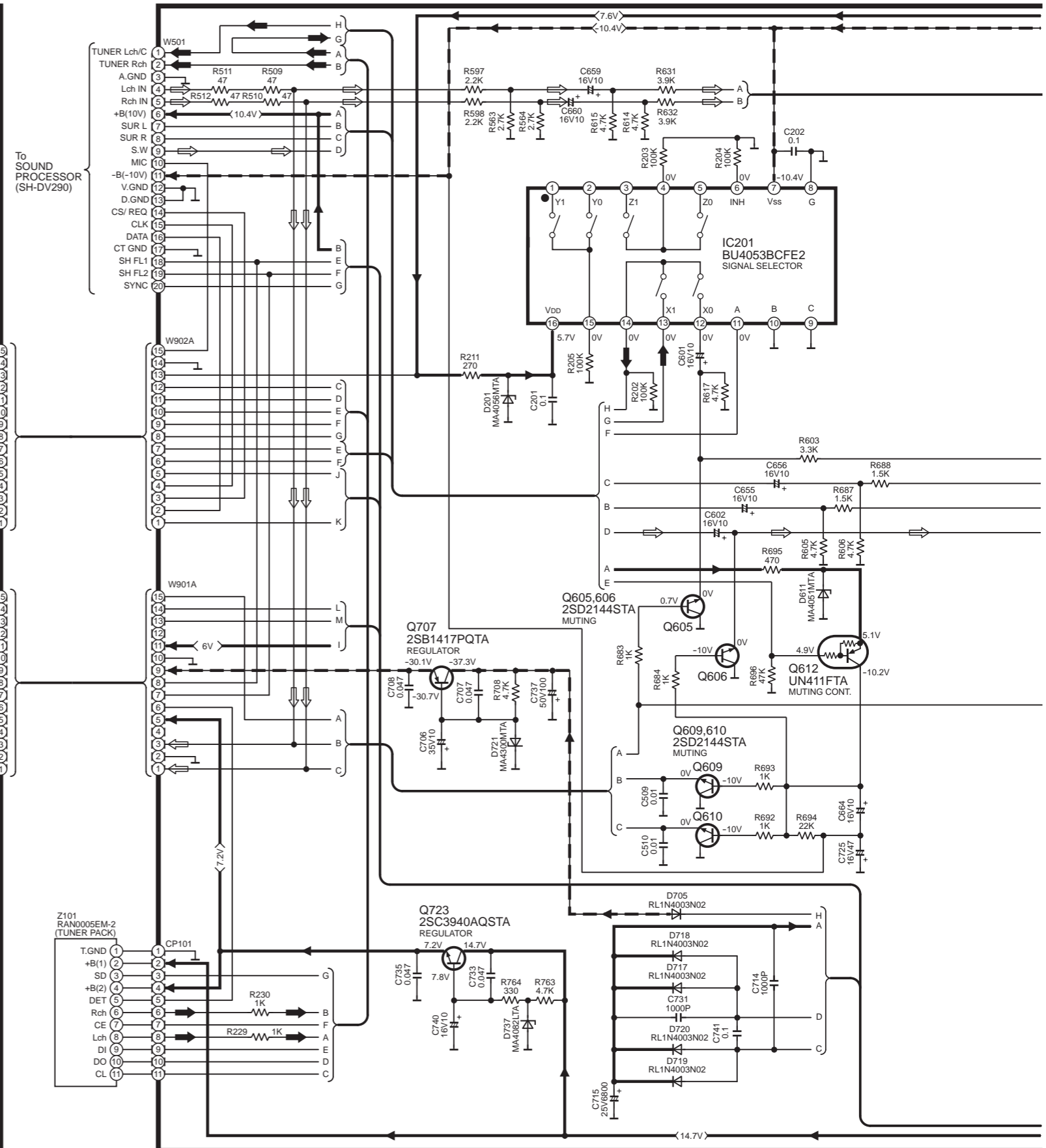
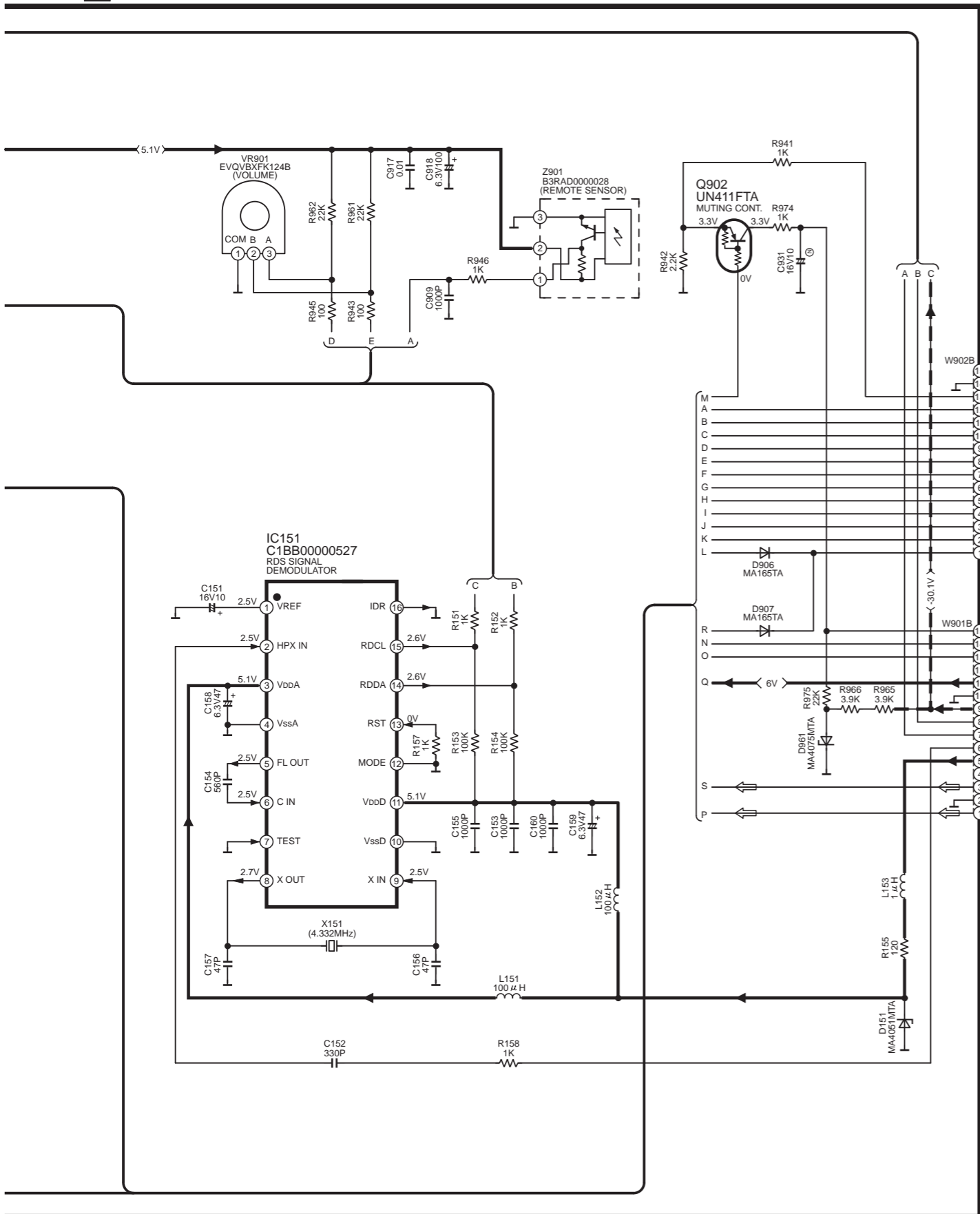

B MAIN CIRCUIT

→ : POSITIVE VOLTAGE LINE
 - - - - : NEGATIVE VOLTAGE LINE
 ⇄ : AUDIO SIGNAL LINE

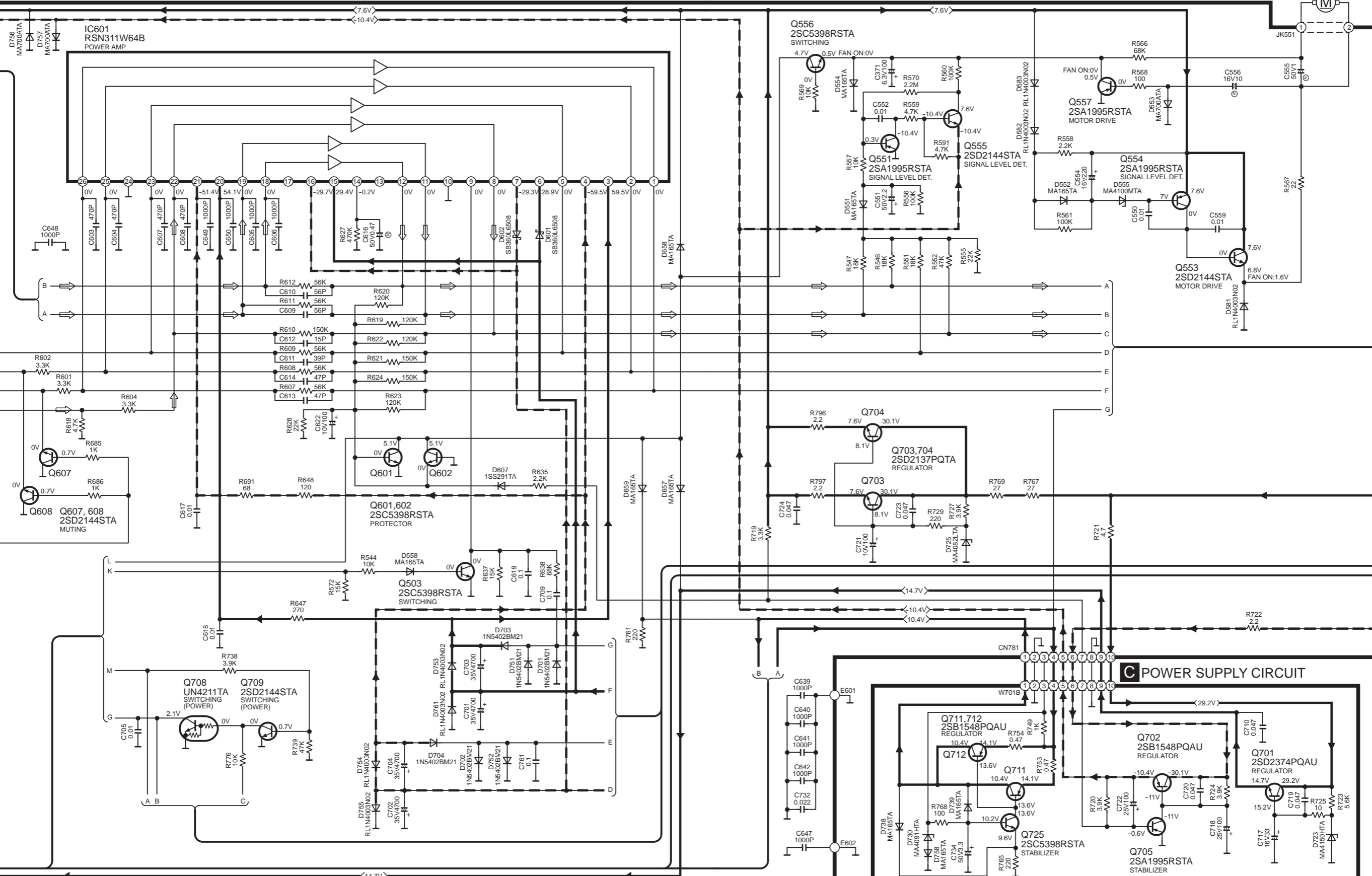

C POWER SUPPLY CIRCUIT

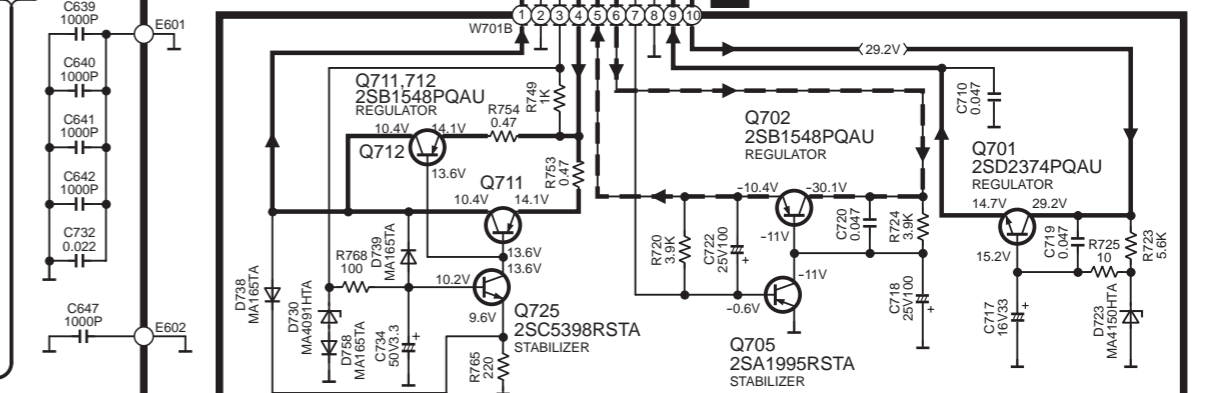

B MAIN CIRCUIT

: POSITIVE VOLTAGE LINE

 : NEGATIVE VOLTAGE LINE

 : AUDIO SIGNAL LINE

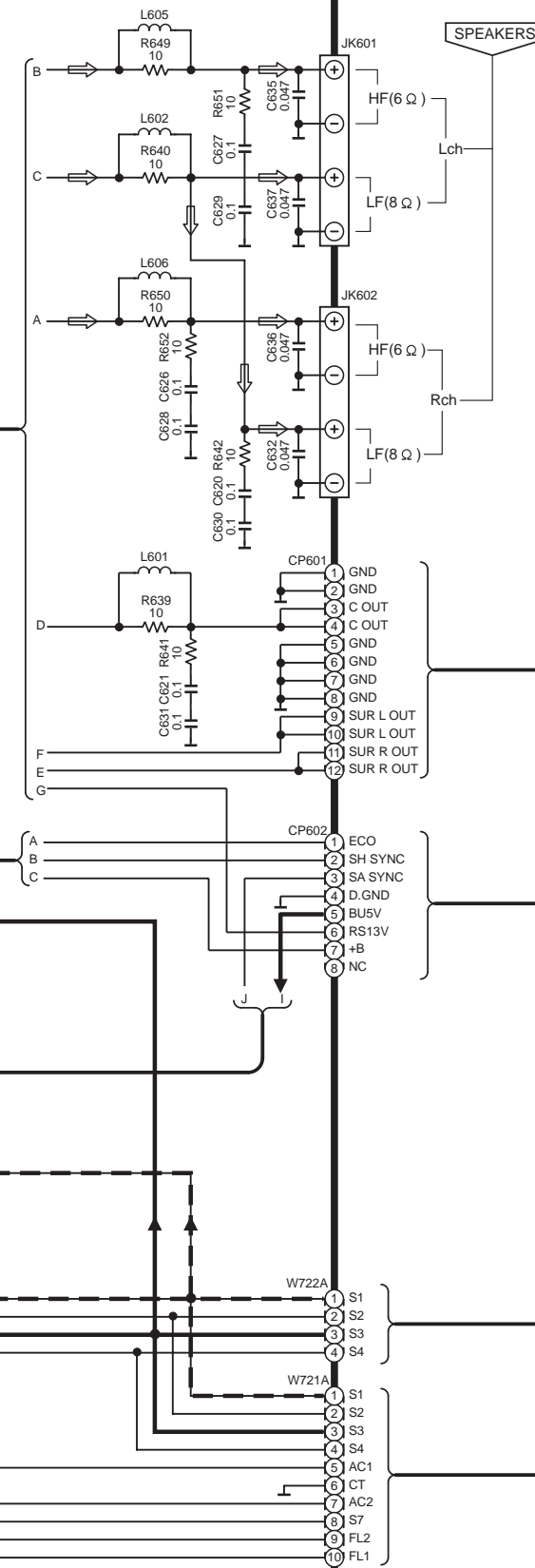

D AC IN CIRCUIT

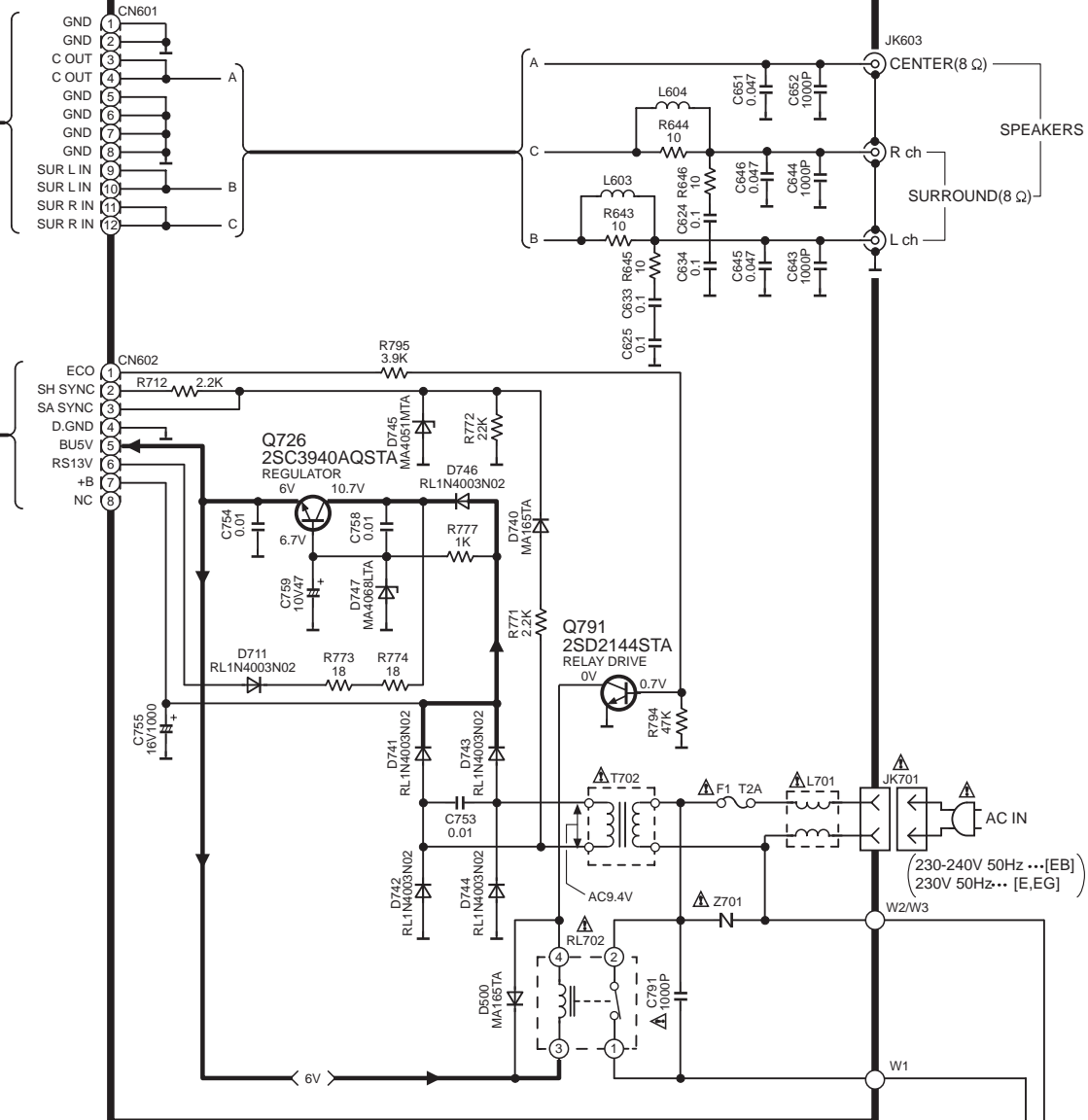

E POWER TRANSFORMER (A) CIRCUIT

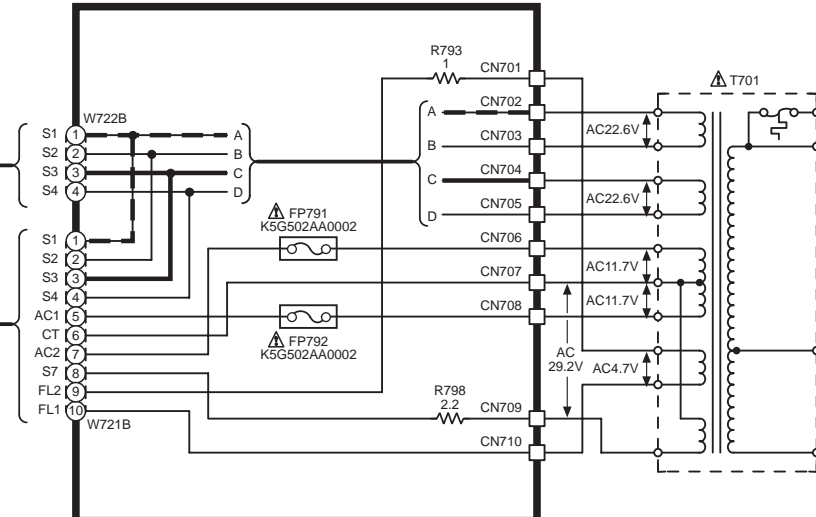

F POWER TRANSFORMER (B) CIRCUIT

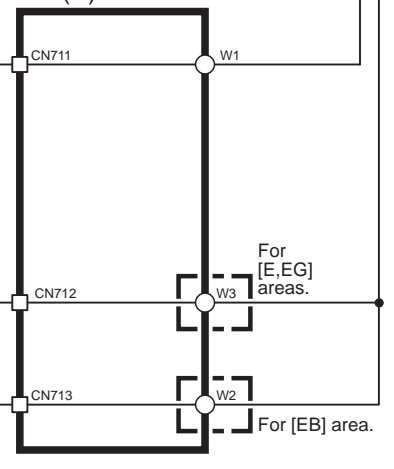

SA-DV290(E,EB,EG) MAIN, AC IN, POWER TRANSFORMER(A)&(B) CIRCUIT DIAGRAM

A OPERATION CIRCUIT

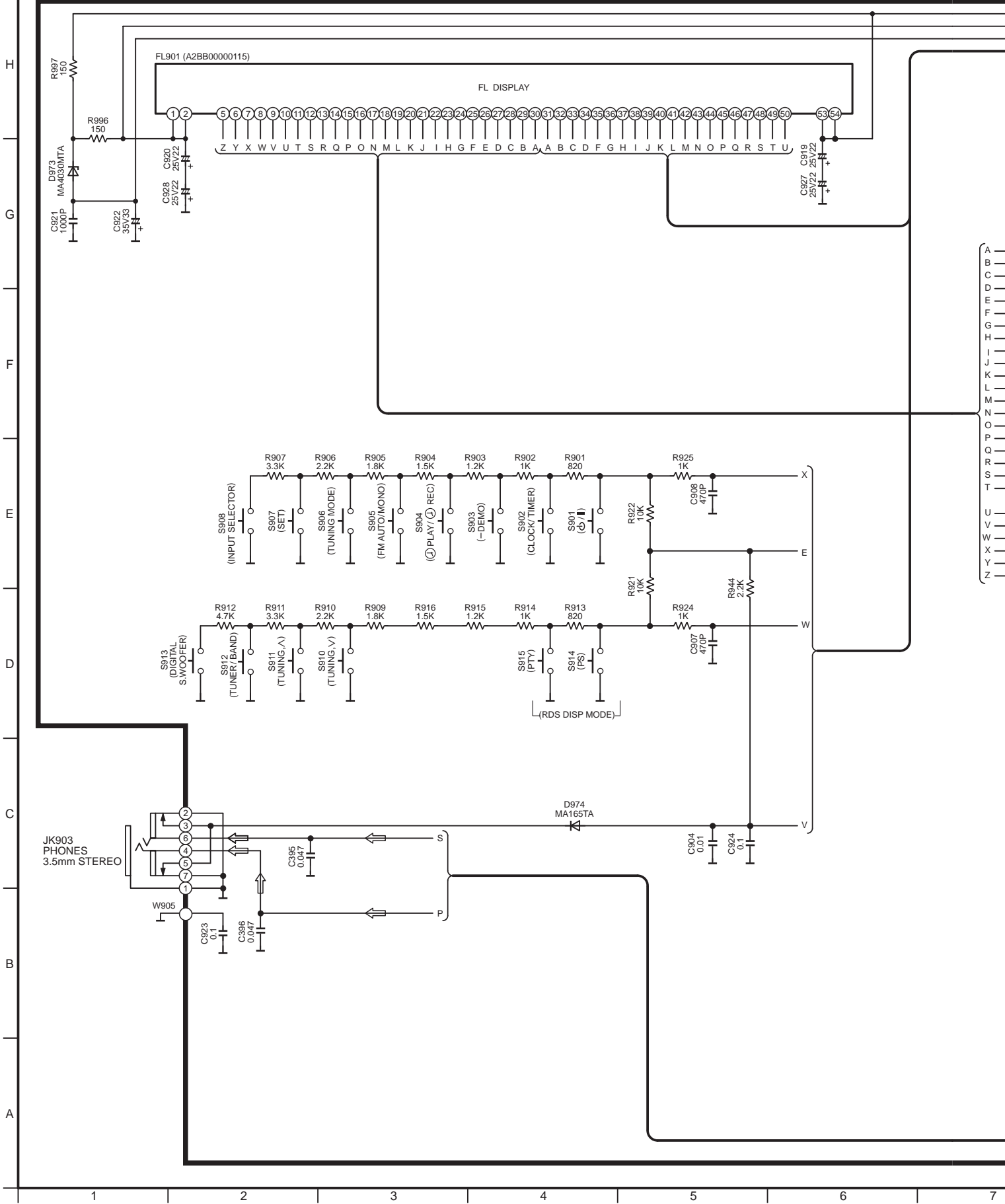

→ : POSITIVE VOLTAGE LINE ← : NEGATIVE VOLTAGE LINE ⇨ : AUDIO SIGNAL LINE

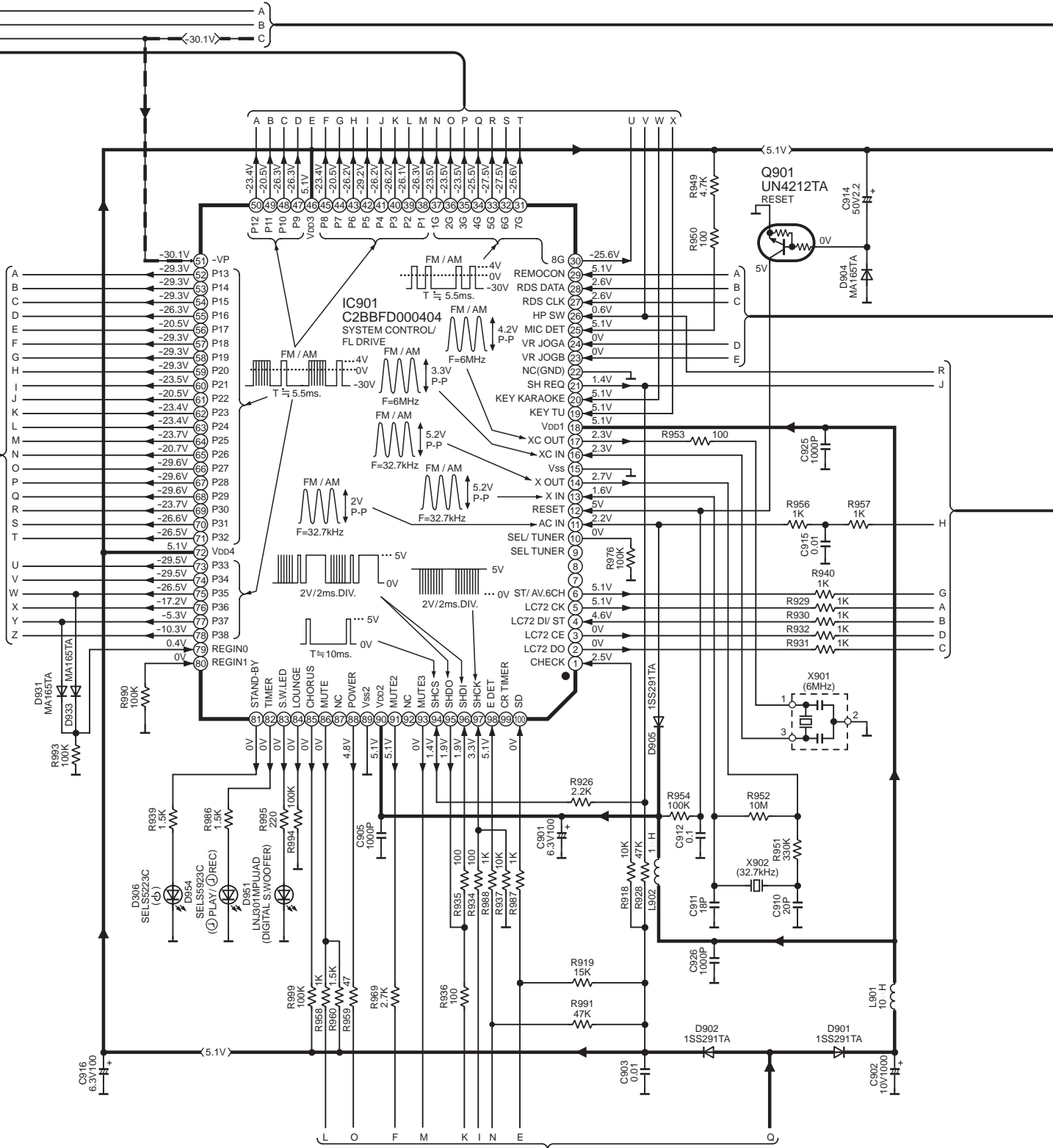

A OPERATION CIRCUIT

: NEGATIVE VOLTAGE LINE : AUDIO SIGNAL LINE
 : POSITIVE VOLTAGE LINE : TUNER SIGNAL LINE

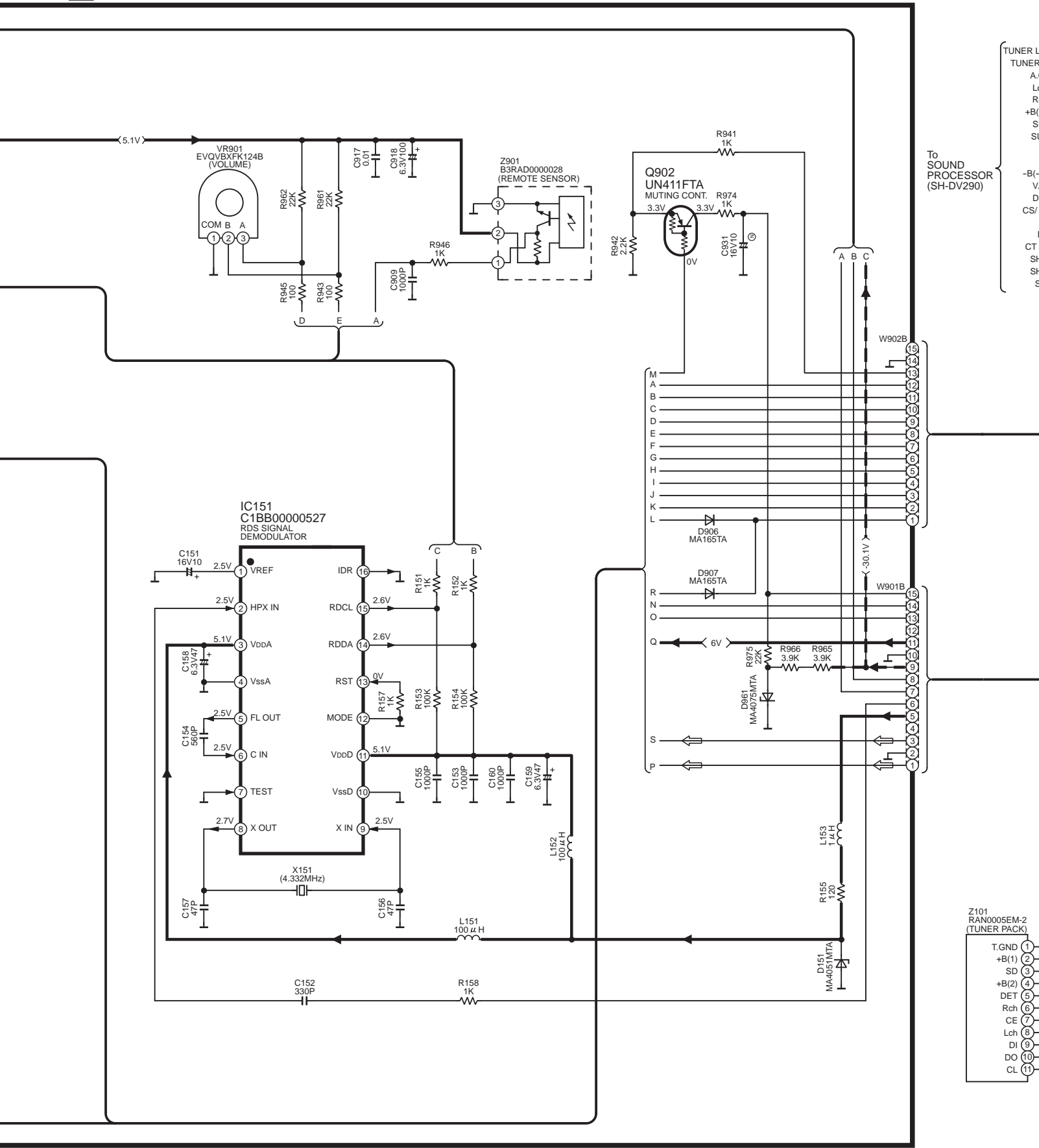

TUNER Lch
TUNER Rch
 A.GN
 Lch L
 Rch
 +B(10)
 SUR
 SUR
 S.
 M
 -B(-10)
 V.GN
 D.GN
 CS/RE
 CI
 DA
 CT GN
 SH F
 SH F
 SYN

To SOUND PROCESSOR (SH-DV290)

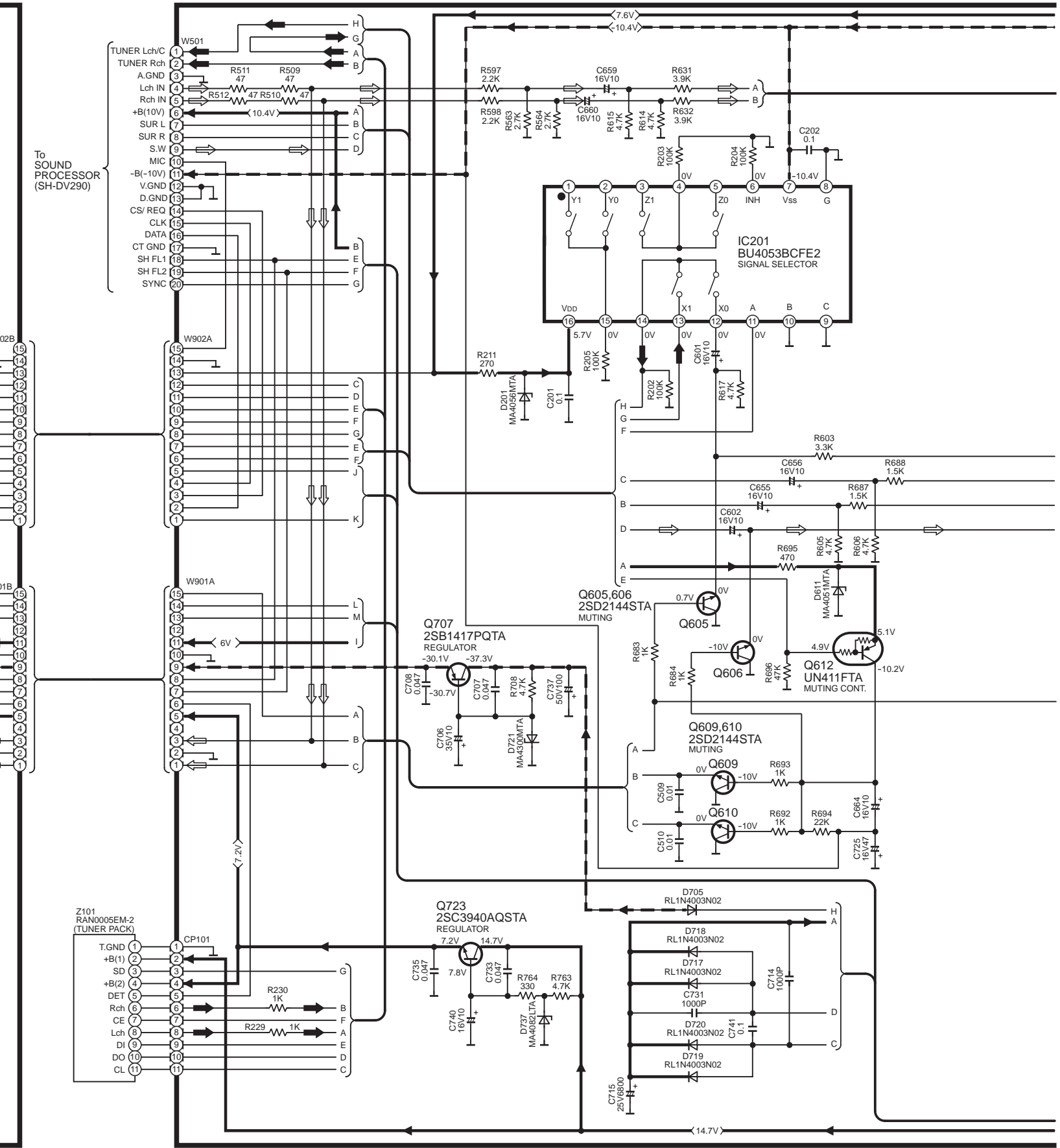

Z101 RAN0005EM-2 (TUNER PACK)
 T.GND (1)
 +B(1) (2)
 SD (3)
 +B(2) (4)
 DET (5)
 Rch (6)
 CE (7)
 Lch (8)
 DI (9)
 DO (10)
 CL (11)

B MAIN CIRCUIT



SA-DV290(E,EB,EG) OPERATION, MAIN CIRCUIT DIAGRAM

B MAIN CIRCUIT

 : POSITIVE VOLTAGE LINE
 : NEGATIVE VOLTAGE LINE  : AUDIO SIGNAL LINE

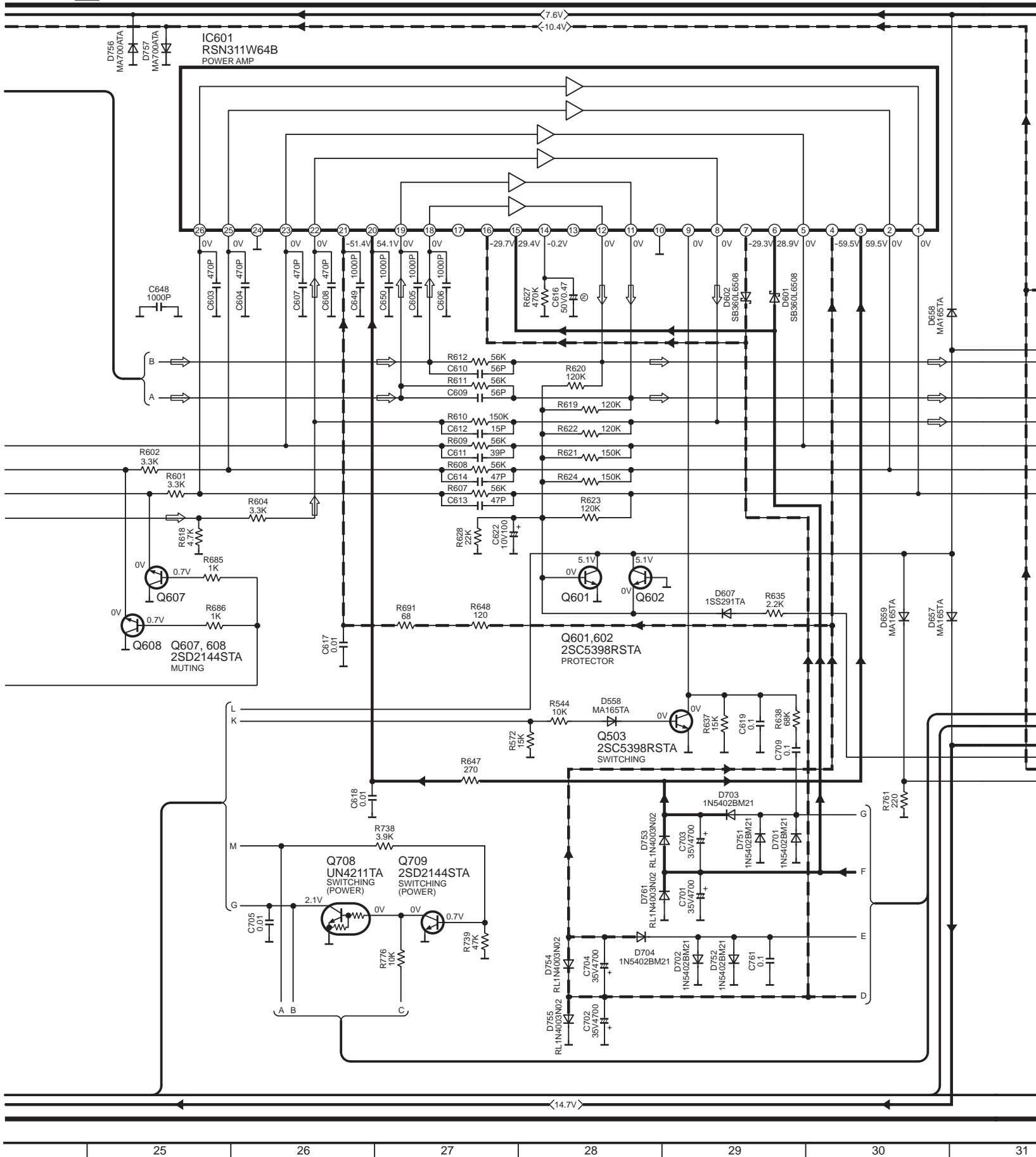

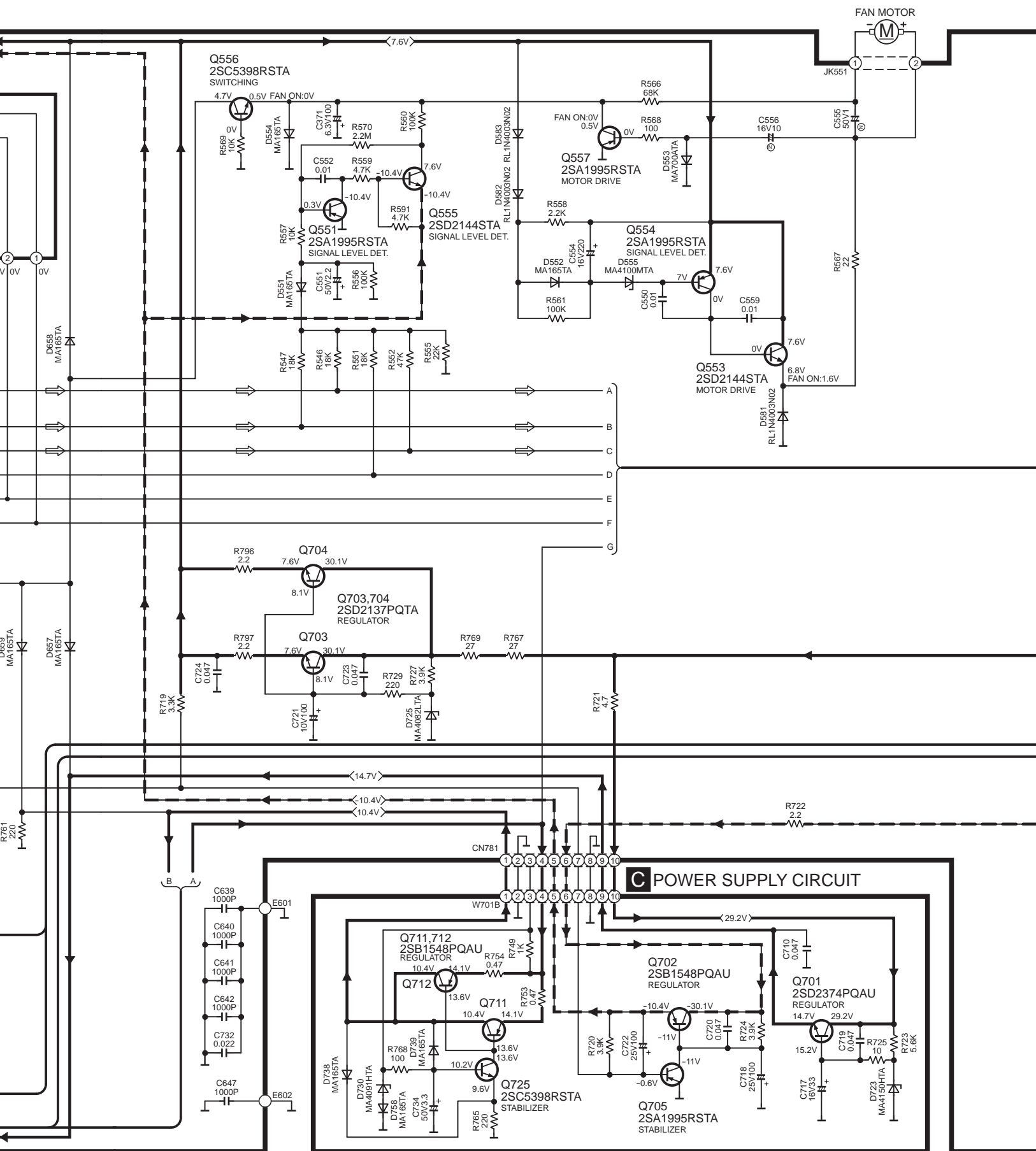

SA-DV290(E,EB,EG) MAIN POWER SUPPLY CIRCUIT DIAGRAM

B MAIN CIRCUIT

: POSITIVE VOLTAGE LINE
 : NEGATIVE VOLTAGE LINE : AUDIO SIGNAL LINE

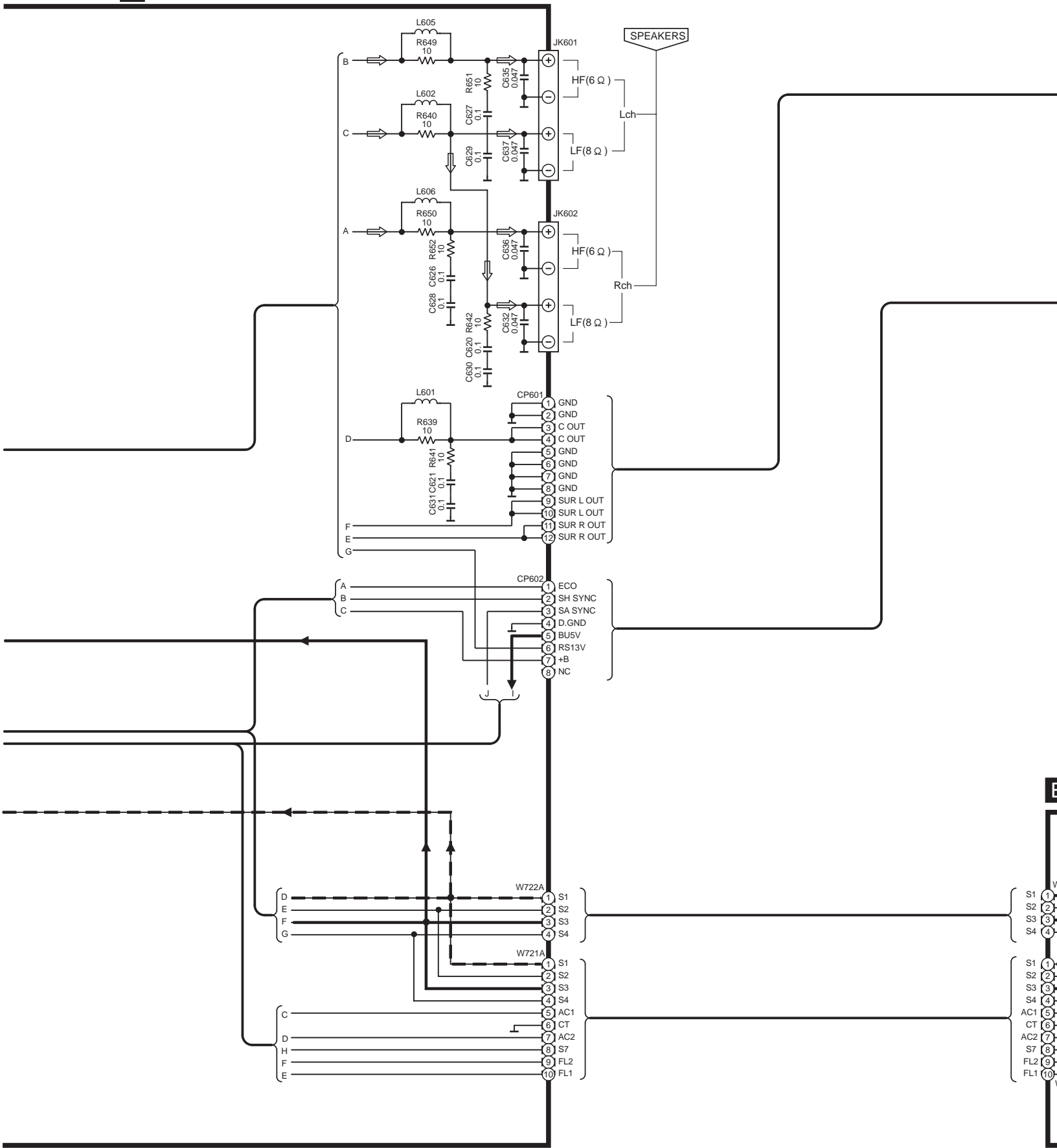

D AC IN CIRCUIT

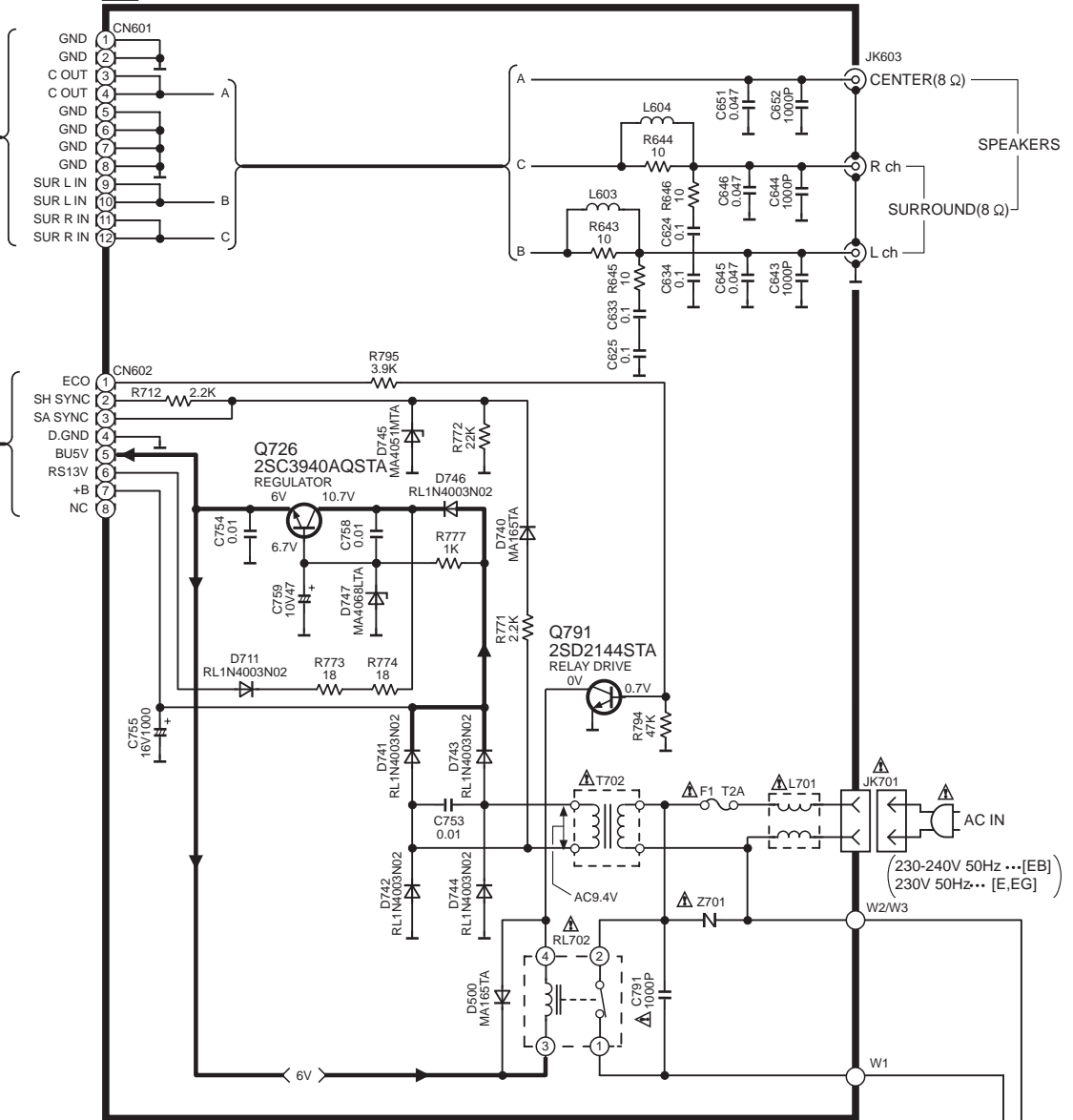

E POWER TRANSFORMER (A) CIRCUIT

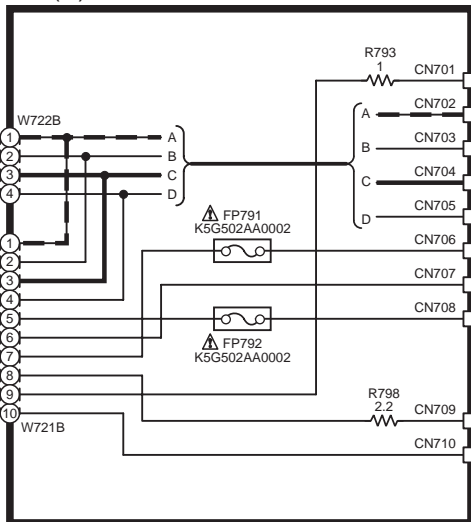

F POWER TRANSFORMER (B) CIRCUIT

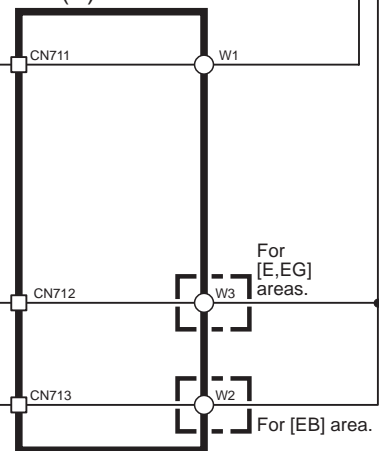

SA-DV290(E,EB,EG) MAIN, AC IN, POWER TRANSFORMER(A)&(B) CIRCUIT DIAGRAM

H
G
F
E
D
C
B
A

BU4053BCFE2
C1BB00000527

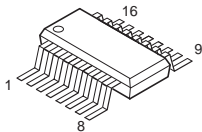

C2BBFD000404

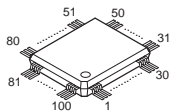

RSN311W64B

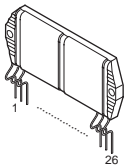

UN411FTA
UN4211TA
UN4212TA



2SB1417PQTA
2SD2137PQTA

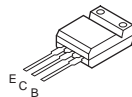

2SD2144STA

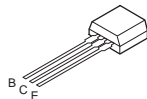

2SA1995RSTA
2SC5398RSTA

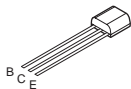

2SC3940AQSTA

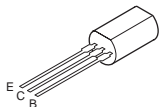

2SB1548PQAU
2SD2374PQAU

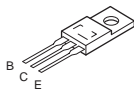

1SS291TA
MA700ATA

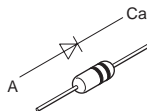

MA4100MTA
MA4150HTA
MA4300MTA

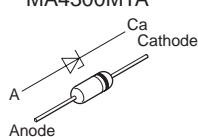

MA165TA

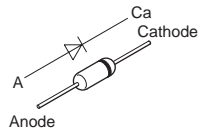

SB360L6508

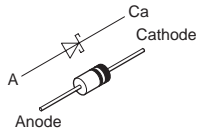

1N5402BM21
RL1N4003N02

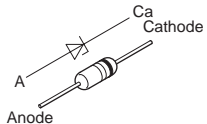
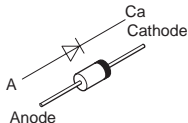

MA4030MTA
MA4051MTA
MA4056MTA
MA4068LTA
MA4075MTA
MA4082LTA
MA4091HTA

LNJ301MPUJAD

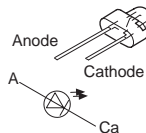

SELS5223C
SELS5923C

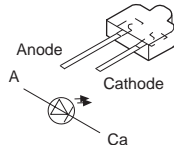

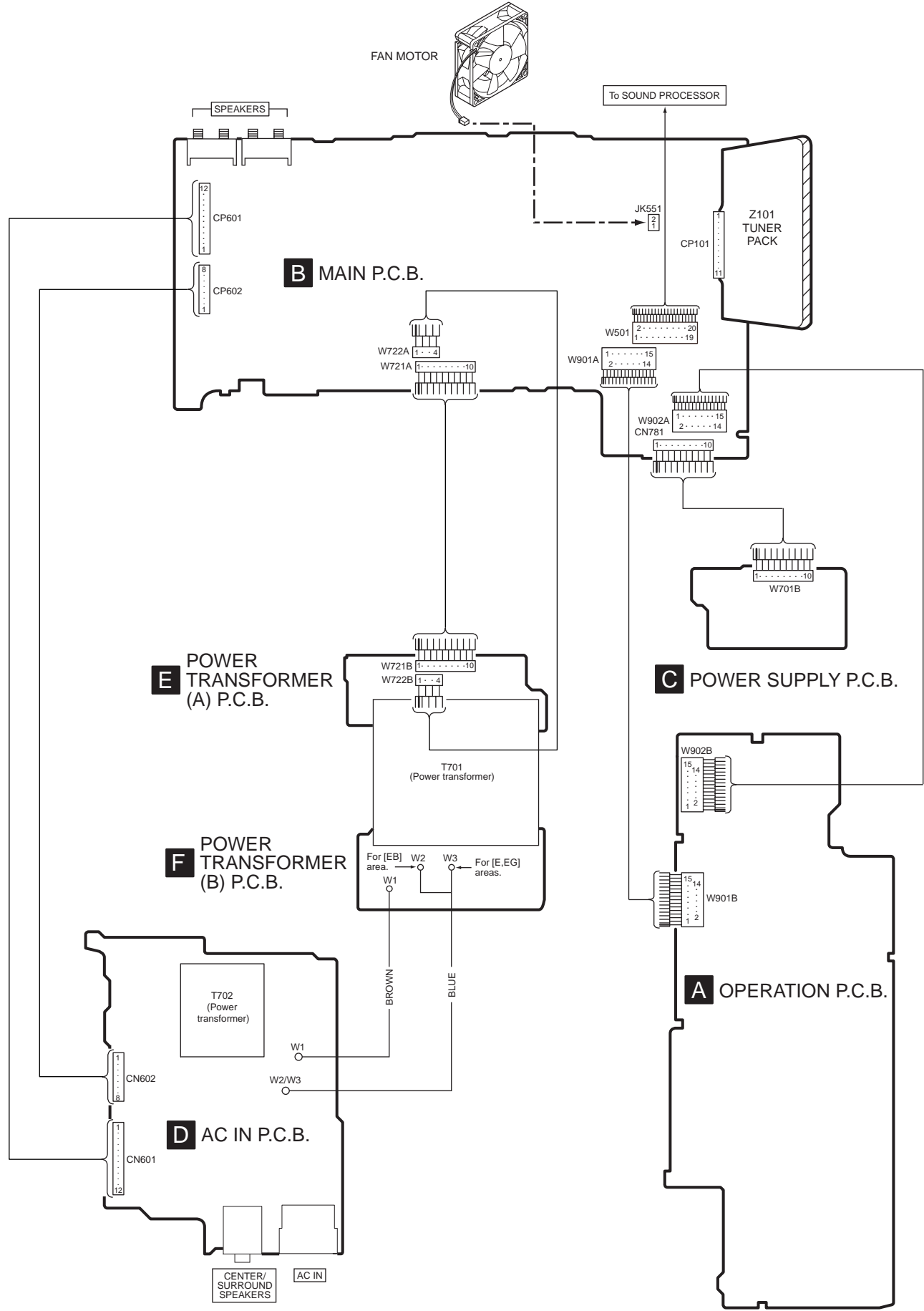

(For United Kingdom)

("EB" area code model only)

For your safety, please read the following text carefully.

This appliance is supplied with a moulded three pin mains plug for your safety and convenience.

A 5-ampere fuse is fitted in this plug.

Should the fuse need to be replaced please ensure that the replacement fuse has a rating of 5-ampere and that it is approved by ASTA or BSI to BS1362.

Check for the ASTA mark  or the BSI mark  on the body of the fuse.

If the plug contains a removable fuse cover you must ensure that it is refitted when the fuse is replaced.

If you lose the fuse cover the plug must not be used until a replacement cover is obtained.

A replacement fuse cover can be purchased from your local dealer.

CAUTION!

IF THE FITTED MOULDED PLUG IS UNSUITABLE FOR THE SOCKET OUTLET IN YOUR HOME THEN THE FUSE SHOULD BE REMOVED AND THE PLUG CUT OFF AND DISPOSED OF SAFELY.

THERE IS A DANGER OF SEVERE ELECTRICAL SHOCK IF THE CUT OFF PLUG IS INSERTED INTO ANY 13-AMPERE SOCKET.

If a new plug is to be fitted please observe the wiring code as shown below.

If in any doubt please consult a qualified electrician.

IMPORTANT

The wires in this mains lead are coloured in accordance with the following code:

Blue: Neutral, Brown: Live.

As these colours may not correspond with the coloured markings identifying the terminals in your plug, proceed as follows:

The wire which is coloured Blue must be connected to the terminal which is marked with the letter N or coloured Black or Blue.

The wire which is coloured Brown must be connected to the terminal which is marked with the letter L or coloured Brown or Red.

WARNING: DO NOT CONNECT EITHER WIRE TO THE EARTH TERMINAL WHICH IS MARKED WITH THE LETTER E, BY THE EARTH SYMBOL  OR COLOURED GREEN OR GREEN/YELLOW.

THIS PLUG IS NOT WATERPROOF - KEEP DRY.

Before use

Remove the connector cover.

How to replace the fuse

The location of the fuse differ according to the type of AC mains plug (figures A and B). Confirm the AC mains plug fitted and follow the instructions below. Illustrations may differ from actual AC mains plug.

1. Open the fuse cover with a screwdriver.

Figure A

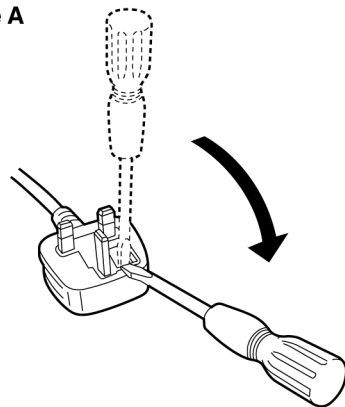
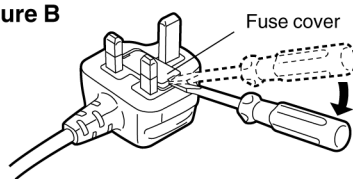

Figure B



2. Replace the fuse and close or attach the fuse cover.

Figure A

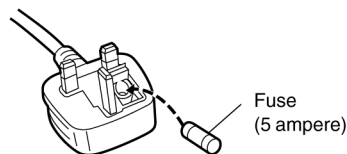
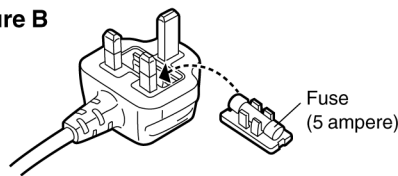
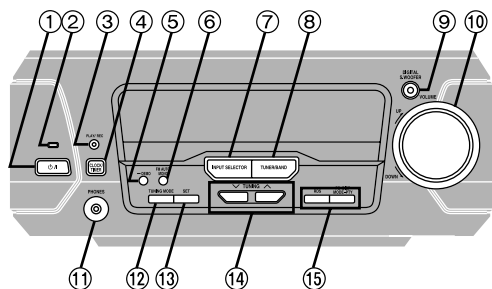
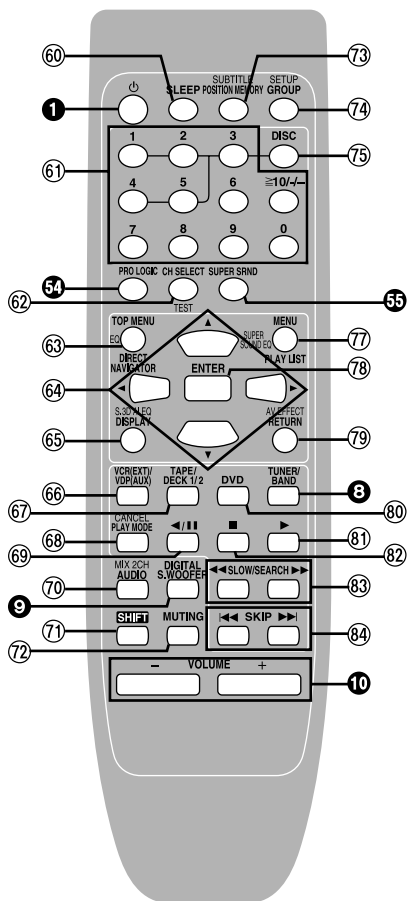

Figure B



A**A Stereo tuner/amplifier**

- ① **Standby/on switch (⏻/⏻)**
Press to switch the unit from on to standby mode or vice versa. In standby mode, the unit is still consuming a small amount of power.
- ② **Standby indicator (⏻)**
When the unit is connected to the AC mains supply, this indicator lights up in standby mode and goes out when the unit is turned on.
- ③ **Play timer/record timer button and indicator (⏻/⏻)**
(⏻ PLAY/⏻ REC)
- ④ **Clock/timer button (CLOCK/TIMER)**
- ⑤ **Demo button (-DEMO)**
- ⑥ **FM mode button (FM AUTO/MONO)**
- ⑦ **Source input button (INPUT SELECTOR)**
- ⑧ **Tuner/band button (TUNER/BAND)**
- ⑨ **Digital super woofer button and indicator (DIGITAL S.WOOFER)**
- ⑩ **Volume control (VOLUME)**
- ⑪ **Headphone jack (PHONES)**
- ⑫ **Tuning mode button (TUNING MODE)**
- ⑬ **Set button (SET)**
- ⑭ **Tuning buttons (∇, ▲ TUNING)**
- ⑮ **RDS display mode button (RDS, PS-DISP MODE-PTY)**

B**B Remote control**

Buttons ①, ③, ⑨, ⑩, ⑬, and ⑮ function in the same way as the controls on the main unit.

- ⑥⑩ **Sleep timer button (SLEEP)**
- ⑥① **Numbered buttons (1-9, 0, ≅10/-/-)**
- ⑥② **Channel select, Test signal button (CH SELECT, TEST)**
- ⑥③ **Top menu, Direct navigator, EQ button (TOP MENU, DIRECT NAVIGATOR, EQ)**
- ⑥④ **Cursor buttons (◀, ▶, ▲, ▼)**
- ⑥⑤ **Display, Super 3D AI EQ button (DISPLAY, S.3D AI EQ)**
- ⑥⑥ **Input select button [VCR (EXT)/VDP (AUX)]**
- ⑥⑦ **Tape select, deck 1/deck 2 select button (TAPE/DECK 1/2)**
- ⑥⑧ **Play mode, Cancel button (PLAY MODE, CANCEL)**
- ⑥⑨ **Disc pause, Tape reverse play button (◀/||)**
- ⑦① **Audio select, 2 channel down mixing button (AUDIO, MIX 2CH)**
- ⑦② **Shift button (SHIFT)**
To operate functions labeled in orange, press [SHIFT] and then the corresponding button at the same time.
- ⑦③ **Muting button (MUTING)**
- ⑦④ **Position memory, Subtitle select button (POSITION MEMORY, SUBTITLE)**
- ⑦⑤ **Group, Initial setting button (GROUP, SETUP)**
- ⑦⑥ **Disc button (DISC)**
- ⑦⑦ **Menu, Play list, Super sound EQ button (MENU, PLAY LIST, SUPER SOUND EQ)**
- ⑦⑧ **Enter button (ENTER)**
- ⑦⑨ **Return, AV effect button (RETURN, AV EFFECT)**
- ⑧① **DVD button (DVD)**
- ⑧② **Disc play, Tape forward play button (▶)**
- ⑧③ **Disc stop, Tape stop button (■)**
- ⑧④ **Disc slow/search buttons (◀◀, ▶▶ SLOW/SEARCH)**
- ⑧⑤ **Disc skip buttons (◀◀◀, ▶▶▶ SKIP)**

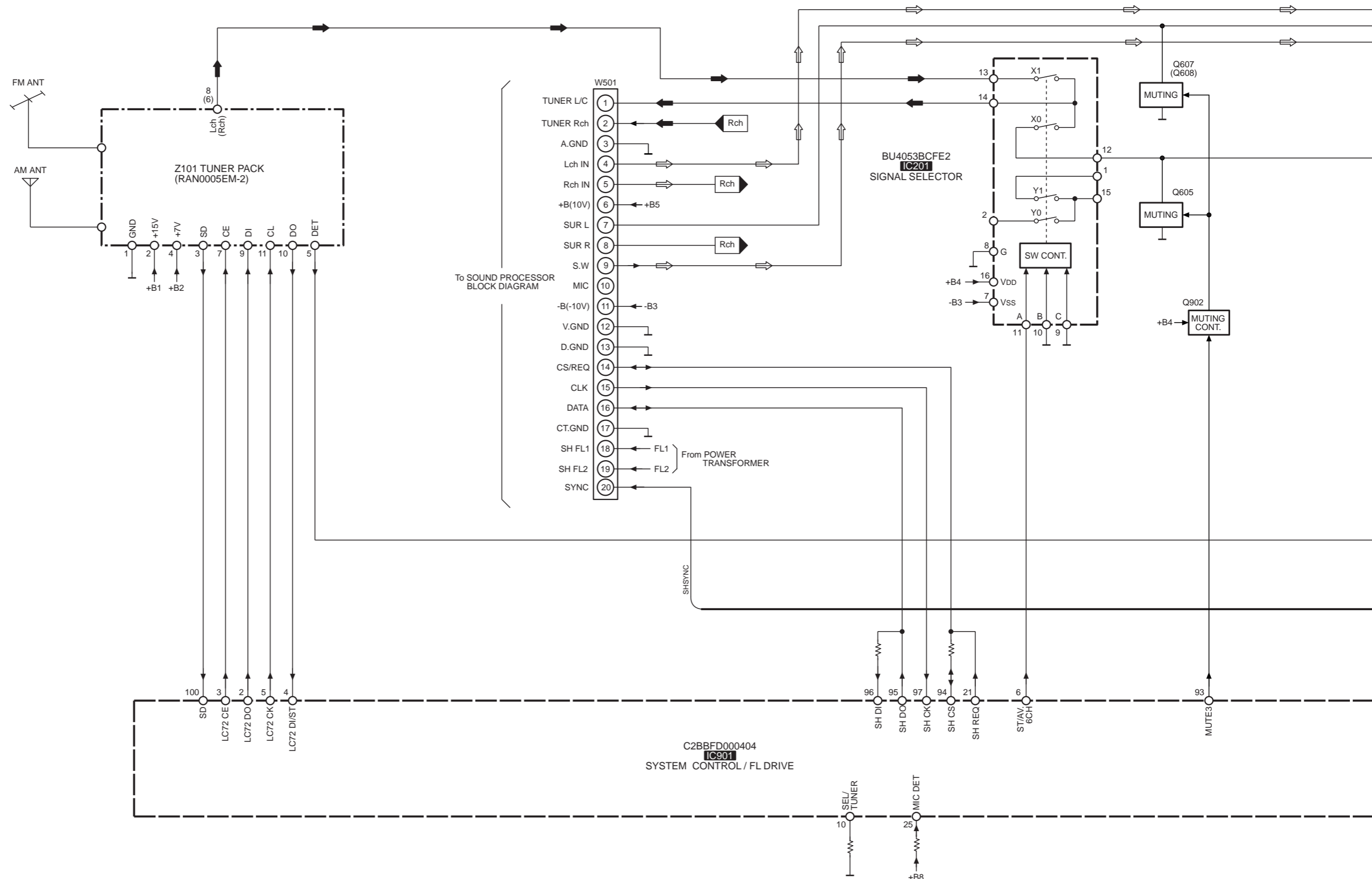

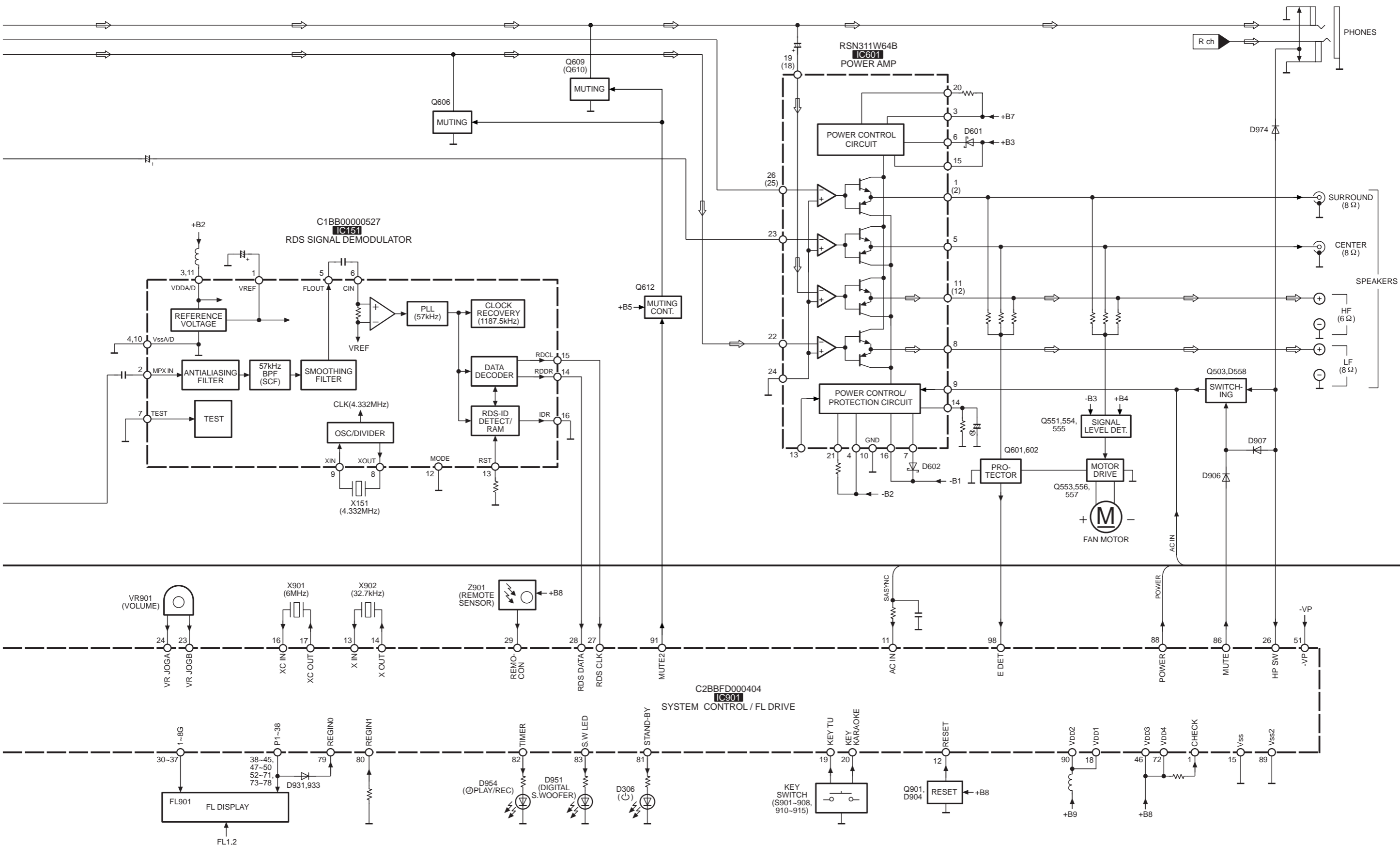

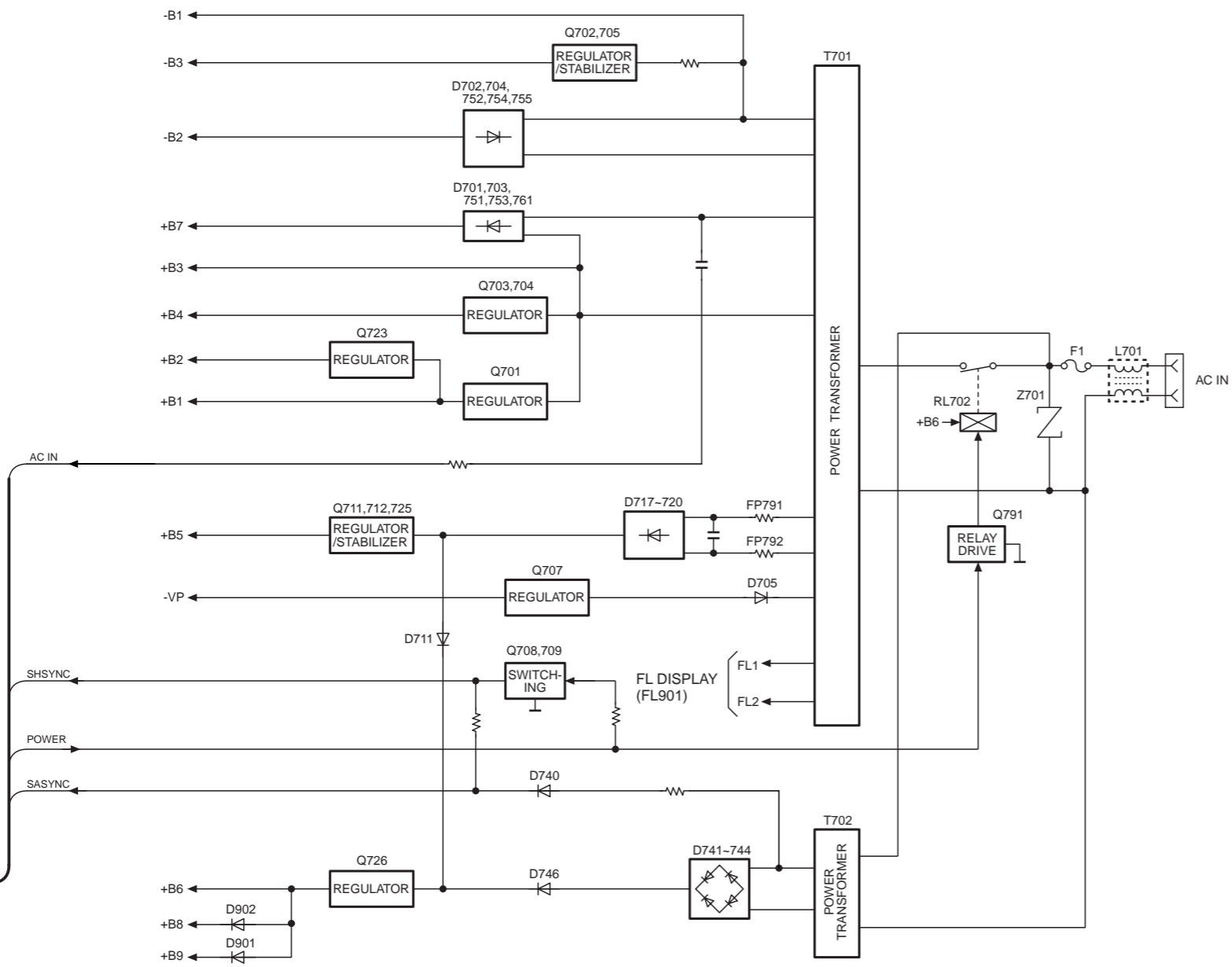

NOTES : ● SIGNAL LINE
 ⇄ : AUDIO SIGNAL
 → : TUNER SIGNAL
 ● () indicates pin No. Right channel.

ORDER NO.AD0305101C8

Service Manual

DVD/Video CD/CD changer



SL-DV290EE / SL-DV290GN

Colour

(s).....Silver Type

System:SC-DV290

Because of unique interconnecting cables, when a component requires service, send or bring in the entire system.

Note: Refer to the service manual for Model No.SA-DV290EE/GN (ORDER NO.AD0305100C8) for information on "ACCESSORIES" and "PACKAGING".

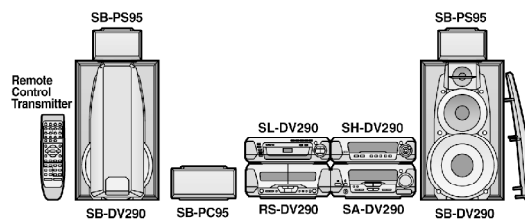

SPECIFICATIONS

Specification

- Discs played (8 cm or 12 cm)
 - DVD-Video/DVD-Audio
 - DVD-RAM/R (DVD-Video format discs)
 - Video CD, CD (CD-DA)
 - MP3/WMA/JPEG format discs)
- Audio
 - No. of channels 5.1 channel (FL, FR, SL, SR, C, SW)
- Video
 - Signal system PAL 625/50, PAL 525/60, NTSC
 - Output level
 - Composite video 1 Vp-p (75 Ω)
 - S-video Y 1 Vp-p (75 Ω)
 - S-video C 0.300 Vp-p (75 Ω) PAL
 - 0.286 Vp-p (75 Ω) NTSC
- Pickup
 - Beam source Semiconductor laser
 - Wavelength 658/790 nm
- General
 - Dimensions (W×H×D) 293×89×288 mm
 - Mass 2.5 kg
 - Power Supply: DC10V
 - Power Consumption: 12W
 - Nots
 - 1.Design and specifications are subject to change without notice.
 - 2.Dimensions and weight are approximate.
 - 3.Total harmonic distortion is measured by the digital spectrum analyzer.
- System/SC-DV290
 - Sound processor: SH-DV290, DVD/ Video CD/ CD changer: SL-DV290, Tuner/ Amplifier: SA-DV290 , Cassette Deck: RS-DV290, Speakers: Front* (SB-DV290),Center* (SB-PC95),Surround* (SB-PS95) (*Madein MESA.)

 **WARNING**

This service information is designed for experienced repair technicians only and is not designed for use by the general public. It does not contain warnings or cautions to advise non-technical individuals of potential dangers in attempting to service a product. Products powered by electricity should be serviced or repaired only by experienced professional technicians. Any attempt to service or repair the product or products dealt with in this service information by anyone else could result in serious injury or death.

Technics

1. Before Repair

This equipment (SL-DV290), which is the component of this system, is supplied with power from the tuner/amplifier (SA-DV290) through the sound processor (SH-DV290). When repairing this equipment or checking operation of the system, be sure to connect the tuner/amplifier and sound

processor with it.

This equipment, even in the state of it as a single equipment, permits power supply and operation check. When operating it as a single equipment without the tuner/amplifier and sound processor, refer to the paragraph of "Measurements and Adjustments."

2. Precaution of Laser Diode

CAUTION:

This product utilizes a laser diode with the unit turned "on", invisible laser radiation is emitted from the pickup lens.

Wave length: 658/790 nm

Maximum output radiation power from pickup: 100 μW/VDE

Laser radiation from the pickup lens is safety level, but be sure the followings:

1. Do not disassemble the optical pickup unit, since radiation from exposed laser diode is dangerous.
2. Do not adjust the variable resistor on the pickup unit. It was already adjusted.
3. Do not look at the focus lens using optical instruments.
4. Recommend not to look at pickup lens for a long time.



LUOKAN 1 LASERLAITE
KLASS 1 LASER APPARAT

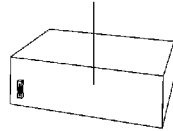

DVD/Video CD/CD Changer
(Back of product)

LUOKAN 1 LASERLAITE
KLASS 1 LASER APPARAT

CAUTION!
THIS PRODUCT UTILIZES A LASER.
USE OF CONTROLS OR ADJUSTMENTS OR PERFORMANCE OF PROCEDURES OTHER THAN
THOSE SPECIFIED HEREIN MAY RESULT IN HAZARDOUS RADIATION EXPOSURE.

ACHTUNG:

Dieses Produkt enthält eine Laserdiode.

Im eingeschalteten Zustand wird unsichtbare Laserstrahlung von der Lasereinheit abgestrahlt.

Wellenlänge: 658/790 nm

Maximale Strahlungsleistung der Lasereinheit: 100 μW/VDE

Die Strahlung der Lasereinheit ungefährlich, wenn folgende Punkte beachtet werden:

1. Die Lasereinheit nicht zerlegen, da die Strahlung an der freigelegten Laserdiode gefährlich ist.
2. Den werkseitig justierten Einstellregler der Lasereinheit nicht verstellen.
3. Nicht mit optischen Instrumenten in die Fokussierlines blicken.
4. Nicht über längere Zeit in die Fokussierlines blicken.

DANGER	- VISIBLE AND INVISIBLE LASER RADIATION WHEN OPEN. AVOIT AVOIT EKSPOSIOIN TIL LASER.	(FDA 21 CFR)
CAUTION	- VISIBLE AND INVISIBLE LASER RADIATION WHEN OPEN. VAROIT EKSPOSIOIN TIL LASER.	(IEC60825-1)
ATTENTION	- RAYONNEMENT LASER VISIBLE ET INVISIBLE EN CAS D'OUVERTURE. RISQUE D'EXPOSITION AU LASER.	
ADVARSEL	- SYNLIG OG USYNLIG LASERSTRÅLING VED ÅBNING. UNSIKTLIG STRÅLING.	
VAROIT	- AVATTAESSÄ OLET AVATTUNA NÄKYLÄÄ JA NÄKYMÄTÖN LASERSTRÅLLE. ÄLÄ KATSO RÄTTEREEN.	
VARNING	- SYNLIG OCH USYNLIG LASERSTRÅLNING NÄR DENNA DEL ÅPENS. RISK FÖR STRÅLNING.	
ADVARSEL	- SYNLIG OG USYNLIG LASERSTRÅLING NÄR DENDEL ÅPNES. UNSIKTLIG STRÅLING.	
VORSICHT	- SICHTBARE UND UNSICHTBARE LASERSTRahlung, WENN AUFGEÖFFNET GEFÄHRDET NICHT DEN STRAHLEN ZUSEHEN.	
注意	- 打开时有可见及不可见激光辐射。避免激光直射眼。	
注意	- この製品はレーザー光線を放射し、目を傷めます。 レーザー光線を避けてください。 (R01.50033)	

(Inside of product)

3. Operating Instructions

4. Handling Precautions for Traverse Deck

The laser diode in the traverse deck (optical pickup) may break down due to potential difference caused by static electricity of clothes or human body. So, be careful of electrostatic breakdown during repair of the traverse deck (optical pickup).

4.1. Handling of traverse deck (optical pickup)

1. Do not give considerable shock to the traverse unit (optical pickup) as it has an extremely high-precise structure.
2. When replacing the optical pickup, install the flexible cable and cut its short land with a nipper. See the optical pickup replacement procedure in this Technical Guide. Before replacing the traverse unit, remove the short pin for preventing static electricity and install

- a new unit. Connect the connector as short time as possible.
3. The flexible cable may be cut off if an excessive force is applied to it. Use caution when handling the cable.
 4. The half-fixed resistor for laser power adjustment cannot be adjusted. Do not turn the resistor.

Fig. 1

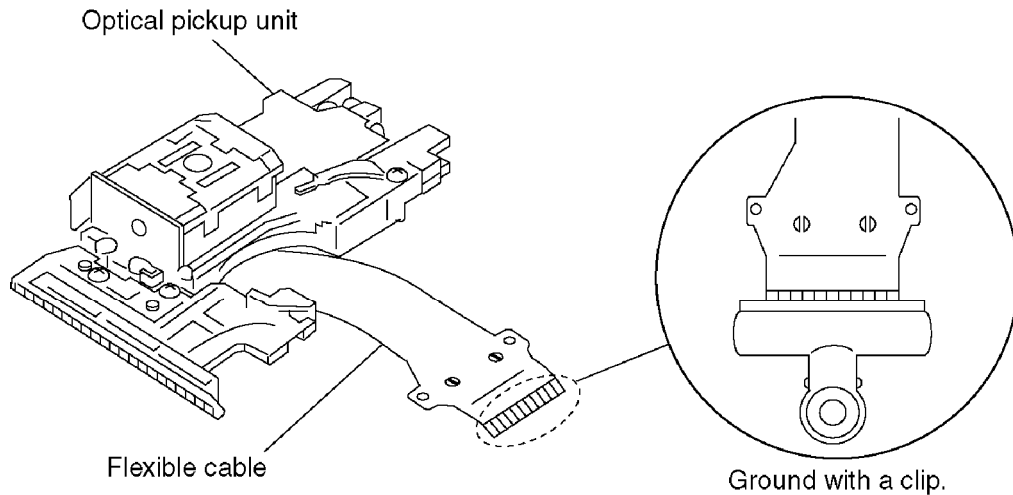

4.2. Replacement procedure for the optical pickup

1. Connect the Flexible cable to the connector on the terminal P.C.B..
2. Cut the optical unit FPC at the point shown below. (As shown in Fig. 2.)

Fig. 2

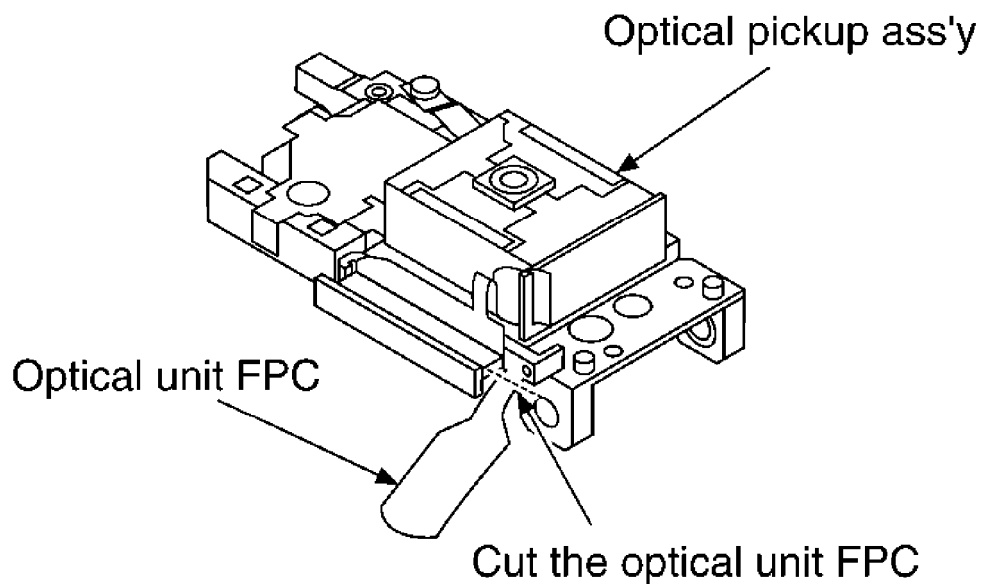

4.3. Grounding for electrostatic breakdown prevention

1. Human body grounding

Use the anti-static wrist strap to discharge the static electricity from your body. (As shown in Fig. 3 .)

2. Work table grounding

Put a conductive material (sheet) or steel sheet on the area where the optical pickup is placed, and ground the sheet.

Caution:

The static electricity of your clothes will not be grounded through the wrist strap. So, take care not to let your clothes touch the traverse deck (optical pickup).

Fig. 3

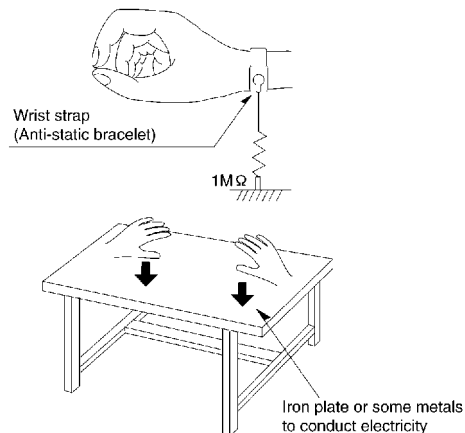

5. Operation Checks and Component Replacement Procedures

- This section describes procedures for checking the operation of the major printed circuit boards and replacing the main components.
- For reassembly after operation checks or replacement, reverse the respective procedures. Special reassembly procedures are described only when required.

Gear for servicing (as jig) information

1. This unit has a gear which used for checking items (Open/close of disc tray, up/down operation of traverse unit by manually) when servicing. (For gear information, that is described on the items for disassembly procedures.)
2. For preparation of gear (for servicing), perform the procedures as follows.
3. In case of re-servicing the same set, the "gear for servicing" may be took off because it had been used. So, the "gear for servicing" must be stored.

1. Remove the gear provided with mechanism cover as shown below.

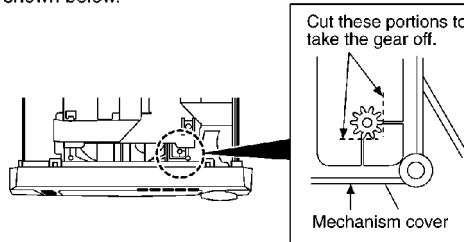

2. Insert the hexagonal wrench (2mm) into the gear, and then project the tip of wrench for 1-2mm length.

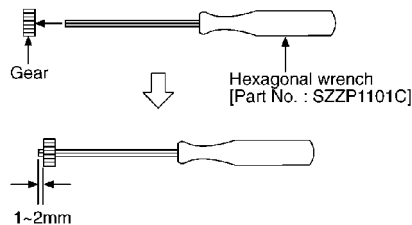

(Preparation of gear as jig is completed.)

5.1. Checking for the DVD module (1) P.C.B.

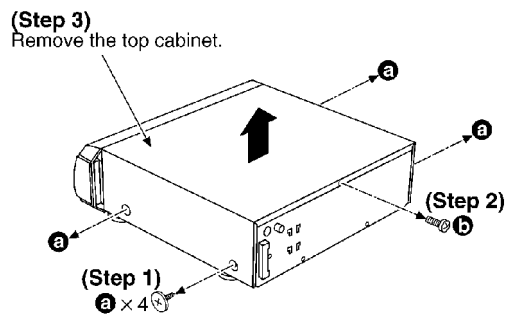

- Check the DVD module (1) P.C.B. (A side) as shown below.

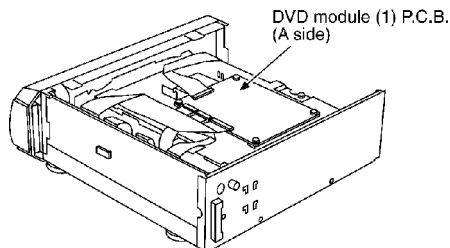

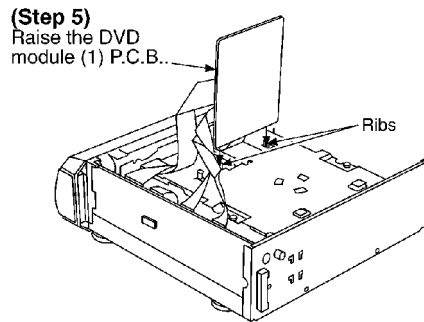
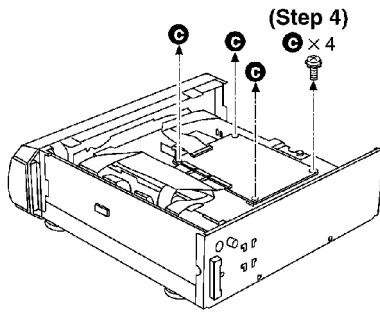

- Check the DVD module (1) P.C.B. (B side) as shown below.

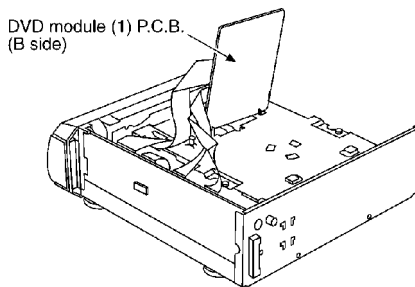

5.2. Checking for the operation P.C.B.

- Follow the (Step 1) - (Step 3) of item 5.1.

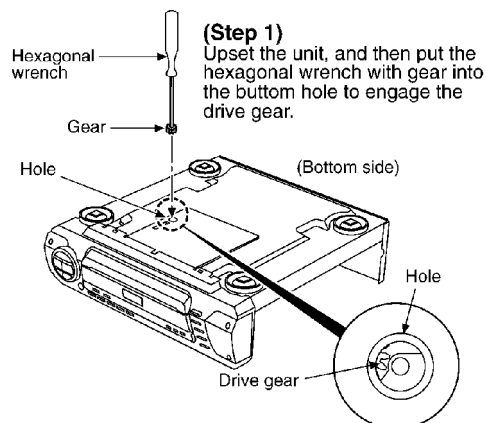

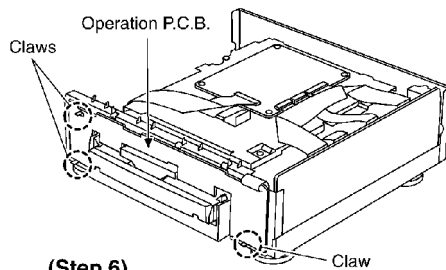

(Step 6)
Release the 3 claws, and then
remove the operation P.C.B..

- Check the operation P.C.B. as shown below.

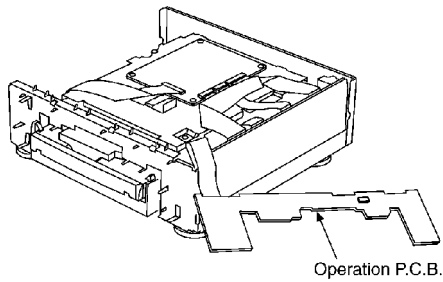

5.3. Checking for the main P.C.B.

- Follow the (Step 1) - (Step 3) of item 5.1.
- Follow the (Step 1) - (Step 5) of item 5.2.

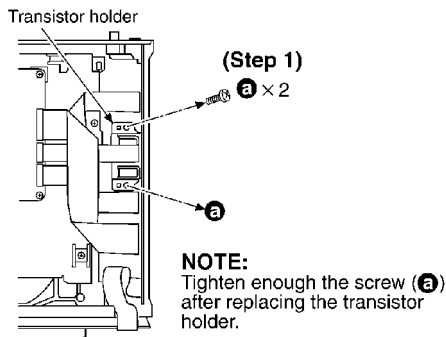

NOTE:
Tighten enough the screw (a) after replacing the transistor holder.

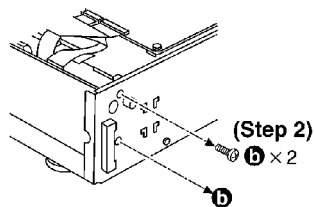

- Check the main P.C.B. as shown below.

(Step 3)
Remove the main P.C.B., and then
place it on the side of unit.

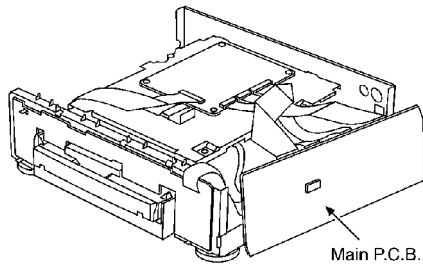

5.4. Checking for the DVD module (2) P.C.B.

- Follow the (Step 1) - (Step 3) of item 5.1.

- Follow the (Step 1) - (Step 5) of item 5.2.

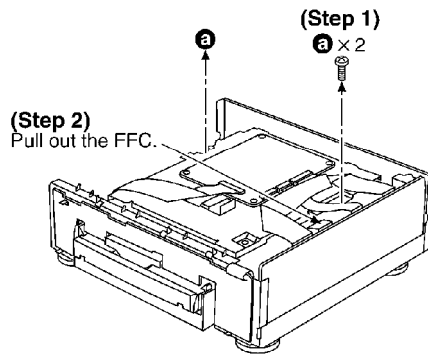

NOTE:
Put in the disc to disc tray.

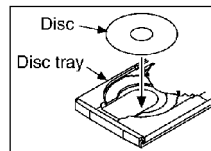

(Step 3)
Remove the loading unit.

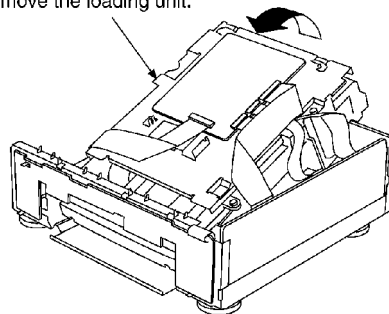

- Check the DVD module (2) P.C.B. as shown below.

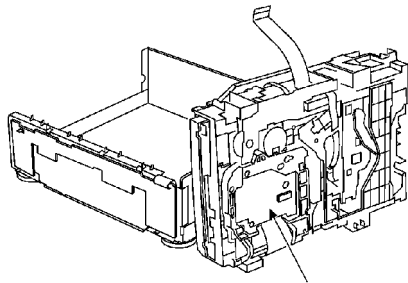

DVD module (2) P.C.B.

5.5. Replacement for the traverse unit

- Follow the (Step 1) - (Step 3) of item 5.1.
- Follow the (Step 1) - (Step 5) of item 5.2.

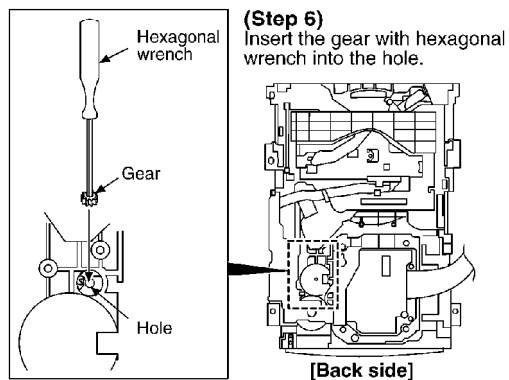
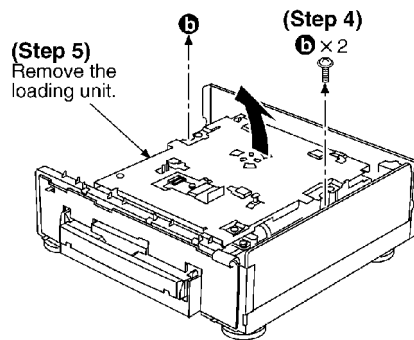
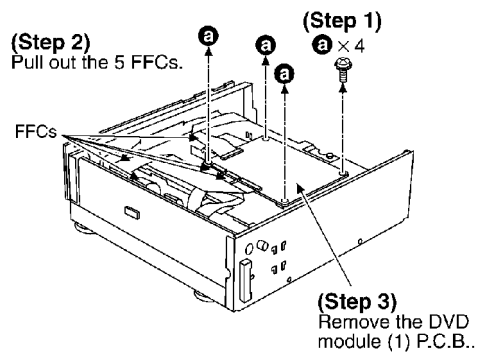

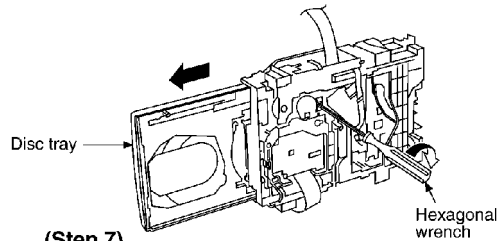

(Step 7)
 Rotate the hexagonal wrench in the direction of arrow, and then open the disc tray fully.

(Step 9)
 Pressing the claw (B) in the direction of arrow ①, the connection lever moves in the direction of arrow ②.

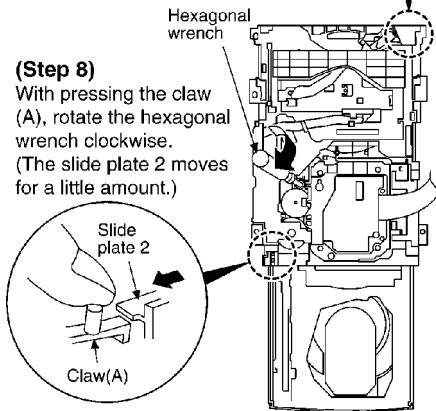
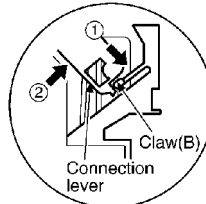

(Step 8)
 With pressing the claw (A), rotate the hexagonal wrench clockwise. (The slide plate 2 moves for a little amount.)

(Step 10)
 Lift up the traverse unit.

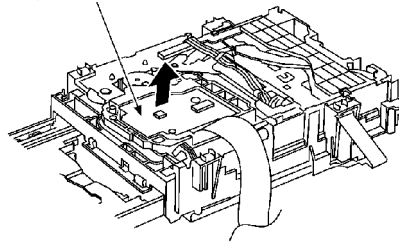

(Step 11)
 Remove the traverse unit from the timing lever.

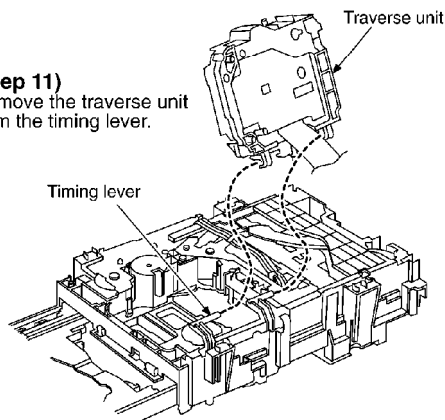

Installation for traverse unit

(Step 1) Install the traverse unit to the timing lever.
(Step 2) Align the boss of traverse unit with the slot of traverse cam gear.

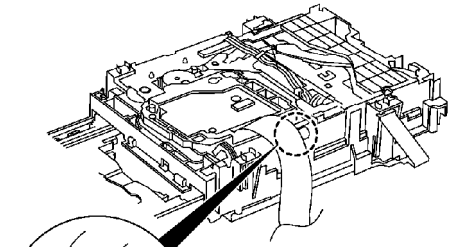
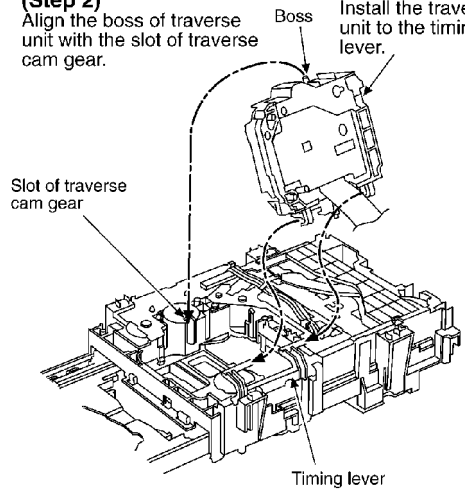

(Step 3) Force the claw of timing lever.
Claw of timing lever

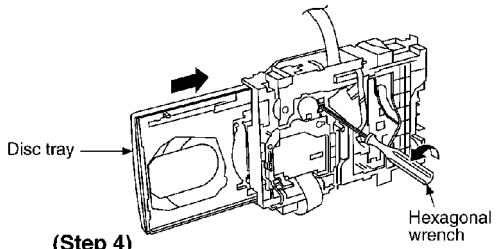

(Step 4) Rotate the hexagonal wrench in the direction of arrow, and then close the disc tray fully.

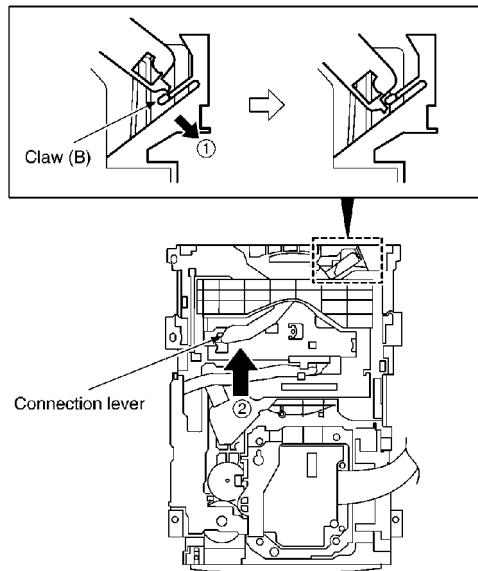

(Step 5)
 With pressing the claw (B) in the direction of arrow ①,
 force the connection lever in the direction of arrow ②.

5.6. Replacement for the disc tray

- Follow the (Step 1) - (Step 3) of item 5.1.
- Follow the (Step 1) - (Step 5) of item 5.5.

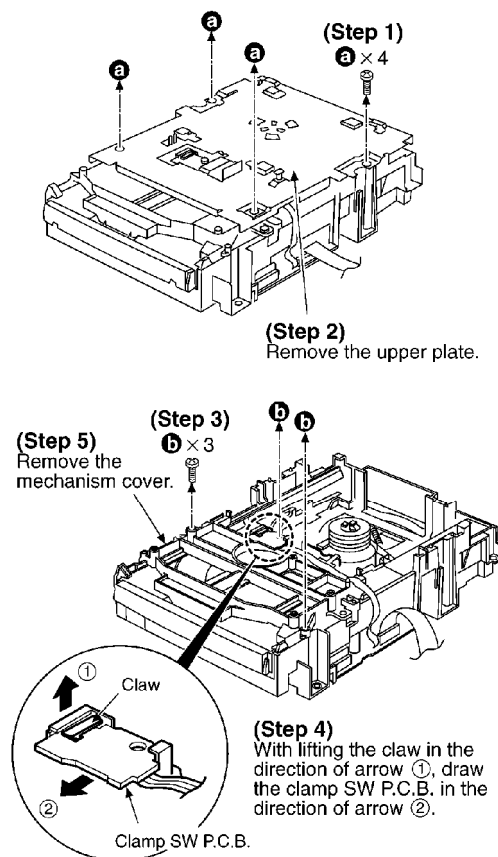

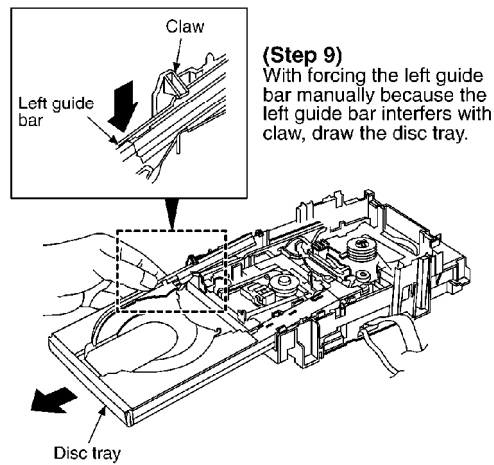
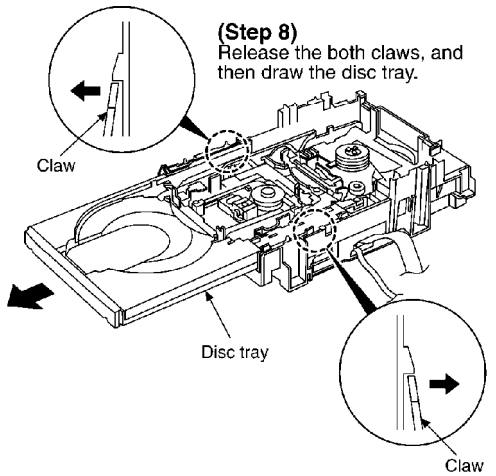
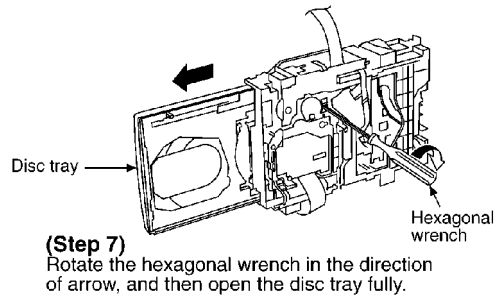
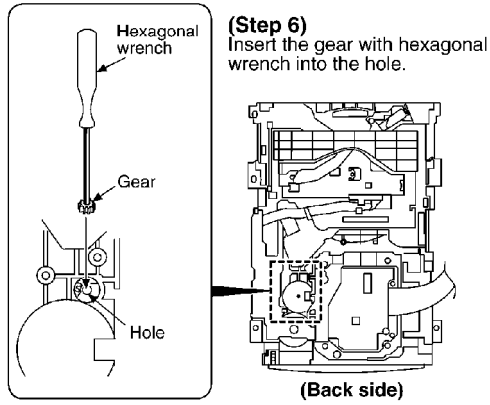

Installation of the disc tray after replacement

(Step 1)
Slide the drive rack fully
in the direction of arrow.

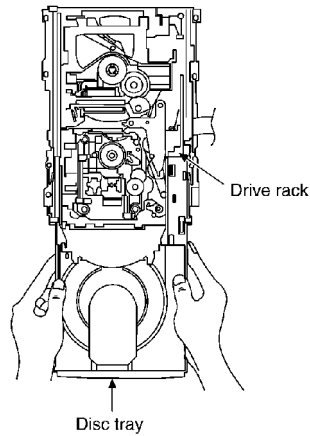
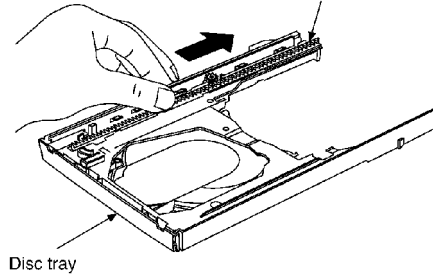

(Step 2)
Holding the drive rack not to move, install the disc tray.

(Step 3)
Align the drive rack
with the drive gear.

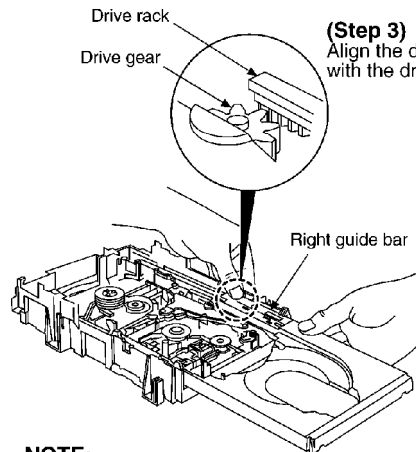

NOTE:
Force the right guide bar of disc tray
manually not to move upwards.

(Step 4)

Holding the disc tray manually, push the disc tray in the direction of arrow.

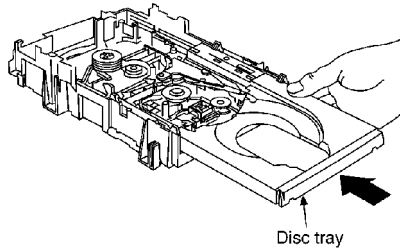

5.7. Disassembly and reassembly for mechanism base drive unit

Disassembly for mechanism base drive unit

- Follow the (Step 1) - (Step 3) of item 5.1.
- Follow the (Step 1) - (Step 11) of item 5.5.
- Follow the (Step 1) - (Step 9) of item 5.6.

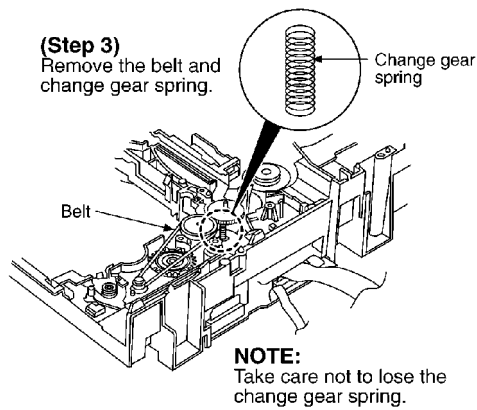
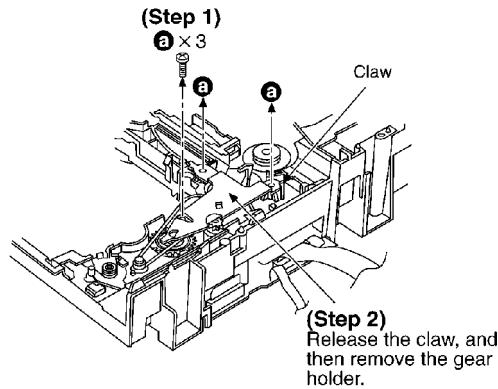

(Step 4)
Remove the pulley gear, change gear and UP/DOWN gear.

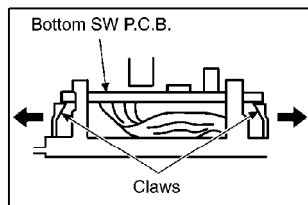
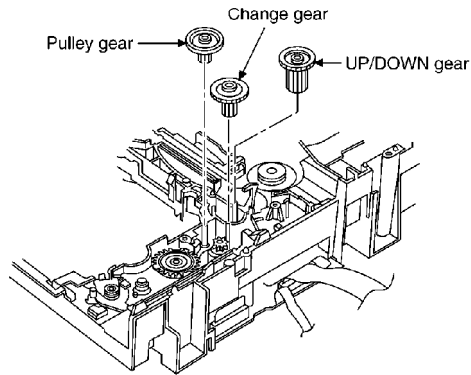

(Step 5)
Release the 2 claws, and then remove the bottom SW P.C.B..

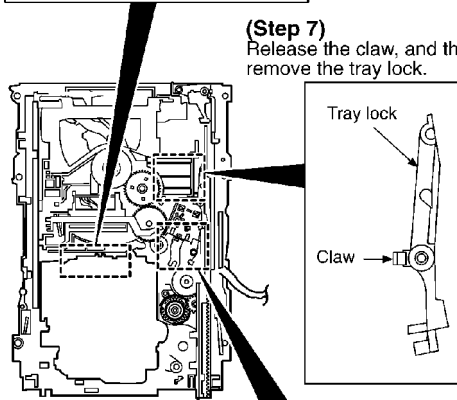

(Step 7)
Release the claw, and then remove the tray lock.

(Step 6)
Install the tray lock spring to the hook temporarily.

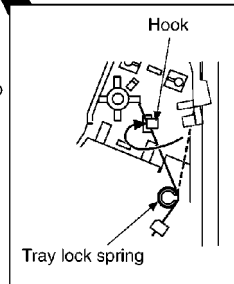

(Step 8)
Release the claw, and
then remove the rear
lock lever.

NOTE:
Take care not take the
rear lock spring off.

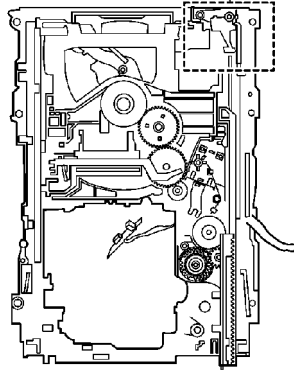
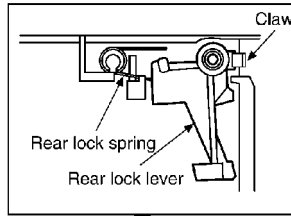

(Step 9)
Pressing the claw (B) in the direction of arrow ①,
force the connection lever in the direction of arrow ②.

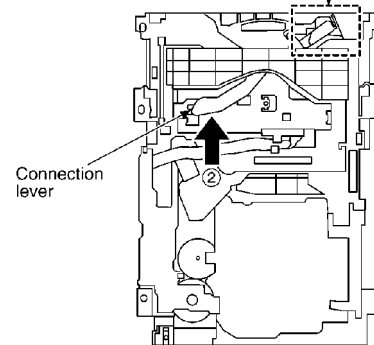
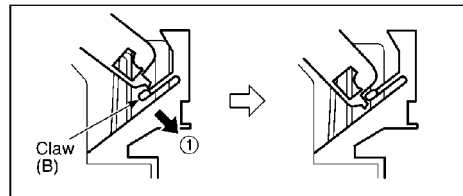

(Step 10)

Move the slide plate 1 to the end of stock side.

(Stock side)

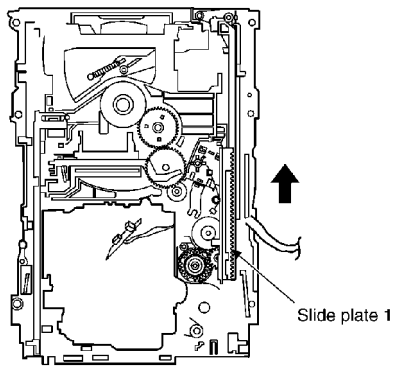

(Step 11)

Lift up the left end of spindle base unit in the direction of arrow ①, and then remove the unit in the direction of arrow ②.

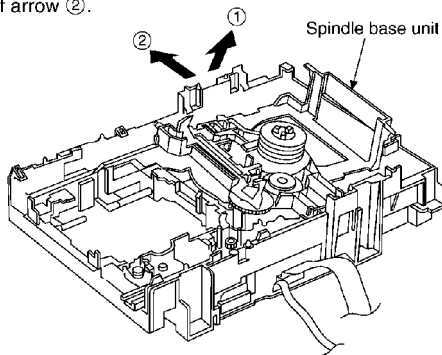

Spindle base unit

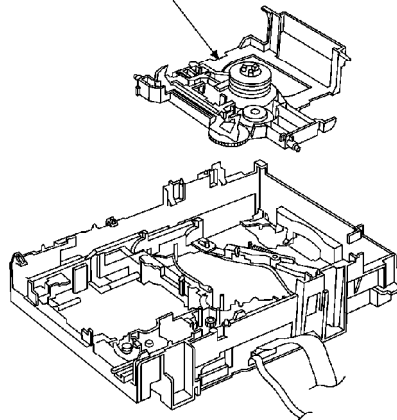

(Step 12)

Remove the slide plate 1 and slide plate 2.

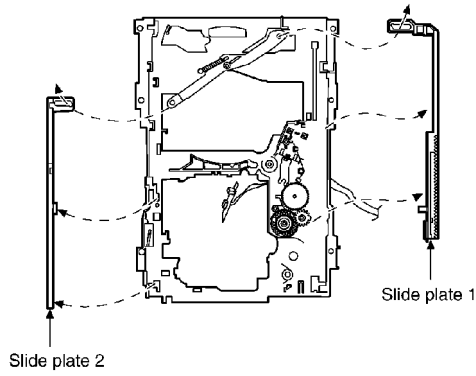

(Step 13)

Remove the traverse relay gear, traverse cam gear and drive gear.

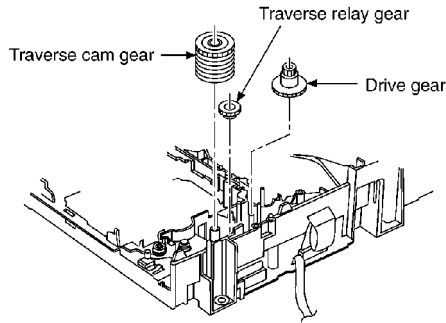

Disassembly/reassembly for the spindle base unit

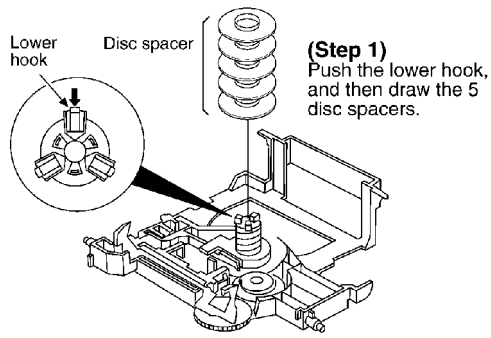

(Step 2)

Pushing the claw, slide the support plate in the direction of arrow, and then remove it.

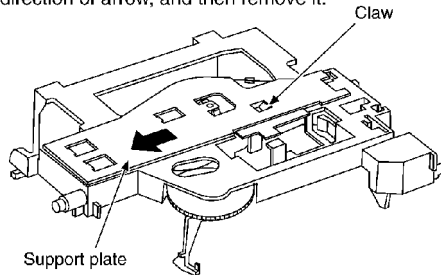

(Installation for disc lever spring)

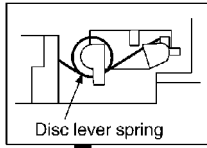

(Step 3)
Rotate the disc lever in the direction of arrow ①, draw the disc lever.

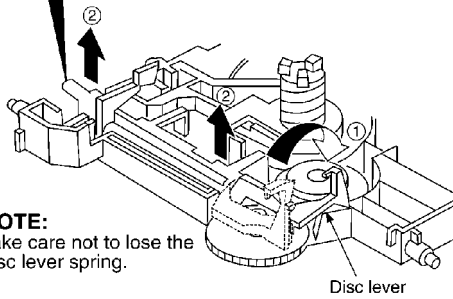

NOTE:
Take care not to lose the disc lever spring.

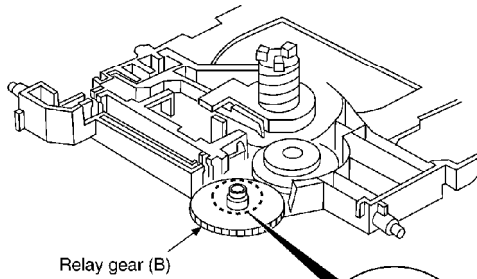

(Step 4)
Release the 2 claws, and then draw the relay gear (B).

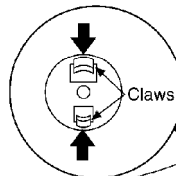
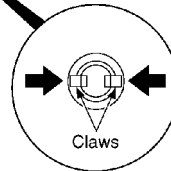

(Step 5)
Release the 2 claws.

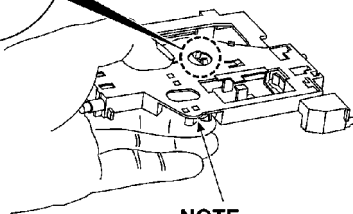

NOTE:
Hold the loading stopper ass'y manually because it is flipped by spring.

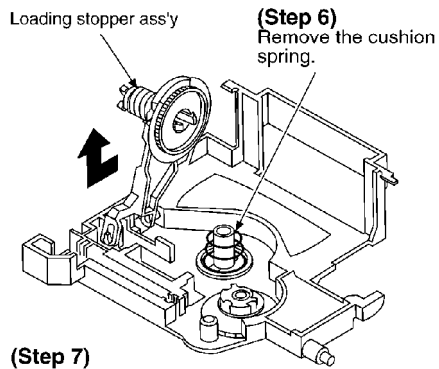

(Step 7)
Remove the loading stopper ass'y in the direction of arrow.

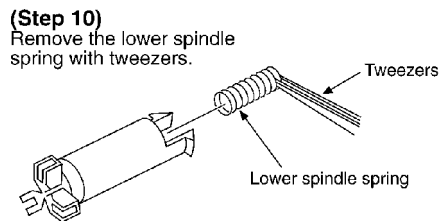
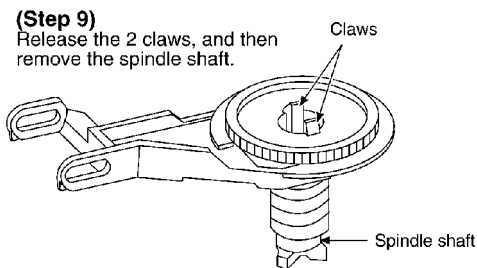
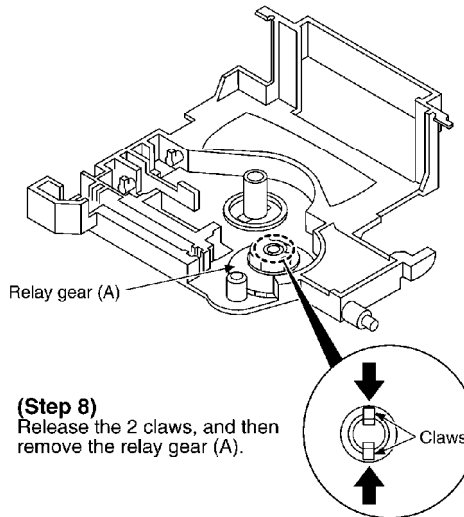

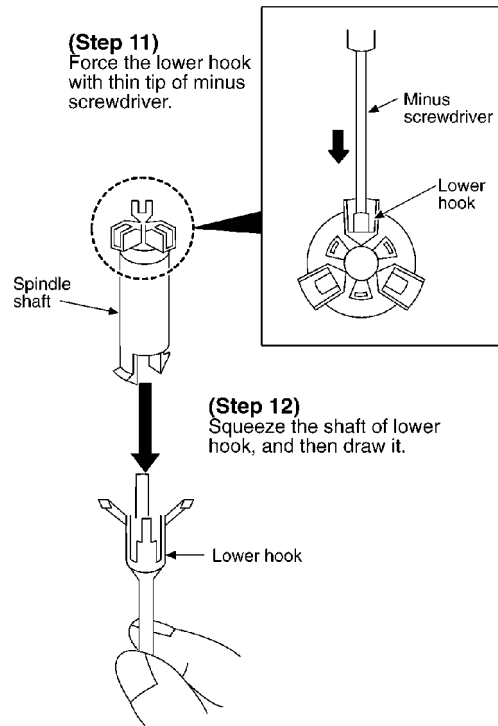

(Step 14)
Insert the thin tip of minus screwdriver between the lower spindle and UP/DOWN base, and then slacken the lower spindle to release the stopper. Then, rotate the lower spindle and remove it.

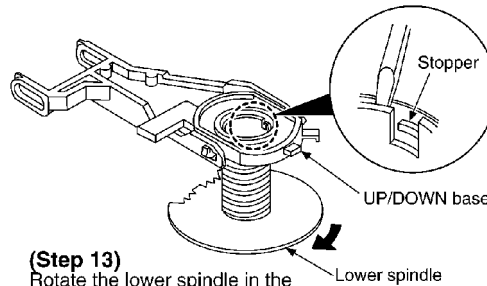

(Step 13)
Rotate the lower spindle in the direction of arrow until the lower spindle interferes with stopper.

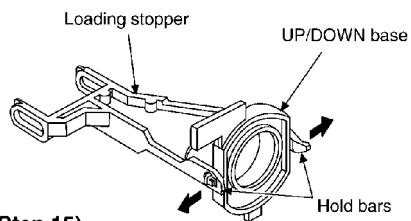

(Step 15)
Rotate the UP/DOWN base at a 90 degree angle. Then, spread the hold bars of loading stopper and remove the UP/DOWN base.

Installation for loading stopper ass'y

(Step 1)

Align the claw of loading stopper ass'y with the slot of spindle base. (Caution should be exercised when alignment of claw due to the size of claws.)

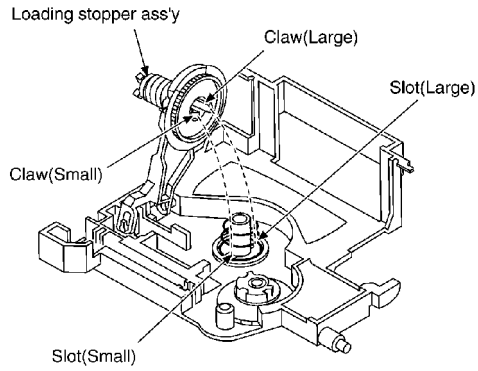

(Step 2)

Lower the loading stopper ass'y, and then align the lower spindle with the trapezoid tooth of relay gear (A).

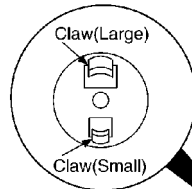
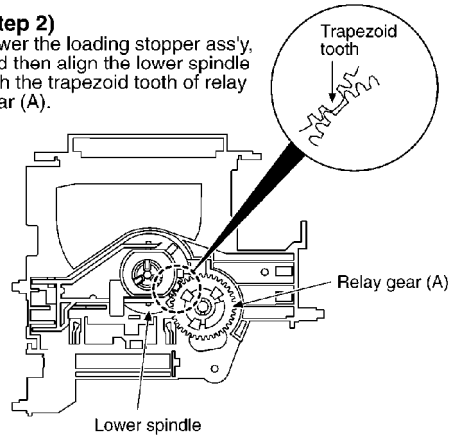

(Step 3)

Force the loading stopper ass'y, latch the claw firmly.

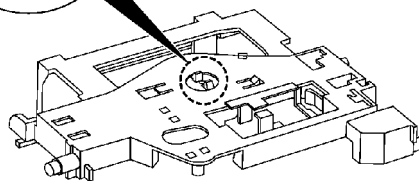

Reassembling for mechanism base drive unit

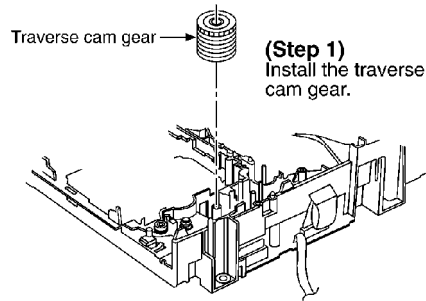

(Step 1)
Install the traverse cam gear.

(Step 2)
Rotate the traverse cam gear to the direction of arrow.

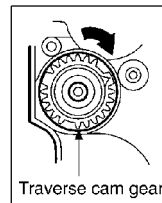

(Step 3)
Install the drive gear and traverse relay gear.

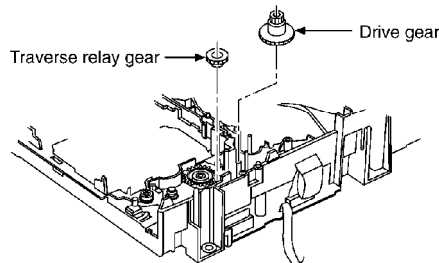

※ When installing the traverse relay gear, align the trapezoid tooth of gear with tooth of traverse cam gear.

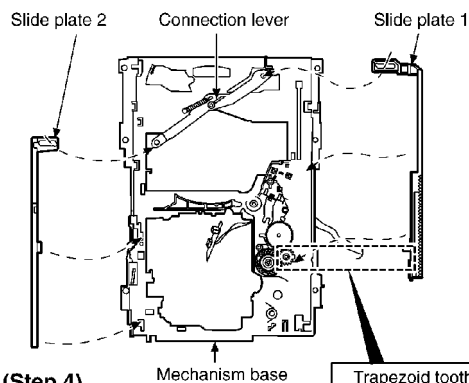
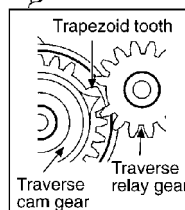

(Step 4)
Install the slide plate 2 to the mechanism base, and then match to the connection lever.

(Step 5)
Install the slide plate 1 to the mechanism base, and then match to the connection lever and align the trapezoid tooth of traverse relay gear with the slide plate 1.

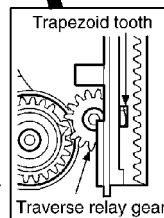

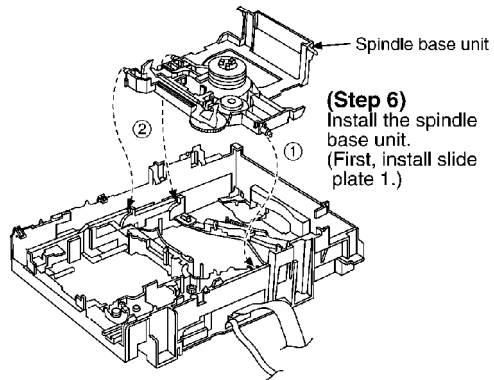

(Step 6)
Install the spindle base unit.
(First, install slide plate 1.)

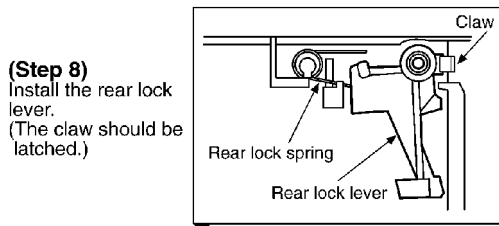

(Step 8)
Install the rear lock lever.
(The claw should be latched.)

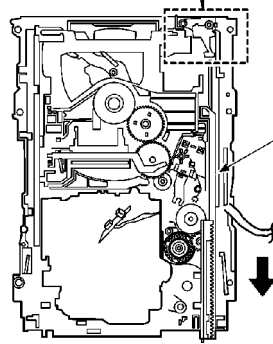

(Step 7)
Move the slide plate 1 to forward fully.

(Front side)

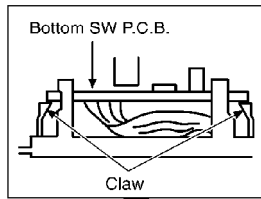

(Step 9)
Install the bottom SW P.C.B..
(The claw should be latched.)

(Step 10)
Install the tray lock.
(The claw should be latched.)

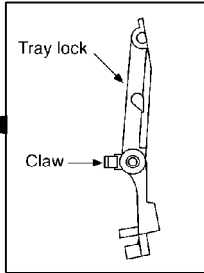
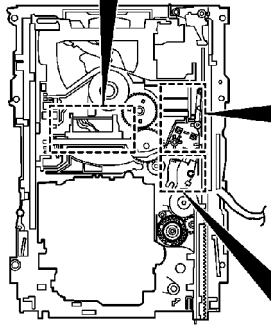

(Step 11)
Remove the tray lock spring from hook, and then latch to the tray lock.

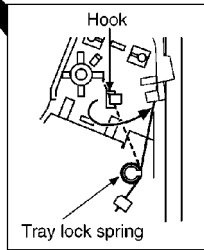

(Step 12)
Install the UP/DOWN gear, change gear, change gear spring, pulley gear and belt in the order of ① - ⑤ .

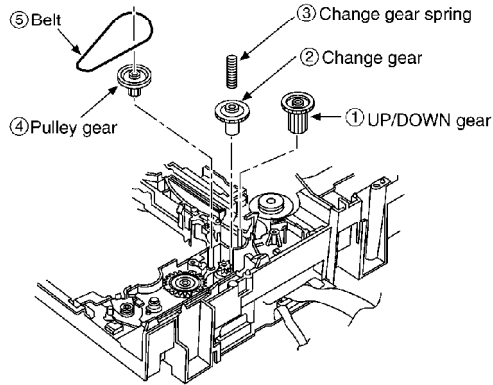

(Step 13)
Install the gear holder,
and then tighten the
screw (a).

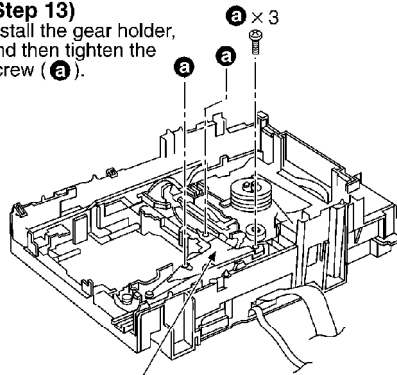

Gear holder

(Step 14)
Install the tray base, traverse ass'y, mechanism cover
and upper plate.
(Refer to the items 5.5. and 5.6. of Main Component
Replacement Procedures.)

[Operation check after servicing]

Check the proper operation of following items with gear
and hexagonal screwdriver.

- 1) Open/close of disc tray.
- 2) Moving the disc tray to the stock side.
- 3) UP/DOWN operation of spindle base unit.
- 4) UP/DOWN operation of traverse ass'y.

5.8. Replacement for the motor ass'y

- Follow the (Step 1) - (Step 3) of item 5.1.
- Follow the (Step 1) - (Step 5) of item 5.5.
- Follow the (Step 1) - (Step 7) of item 5.6.

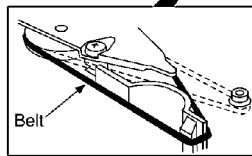
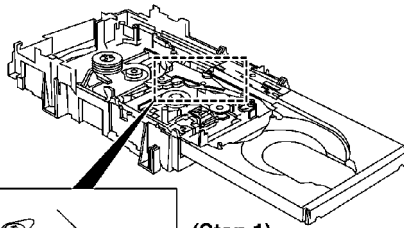

(Step 1)
Install the belt temporarily.

NOTE:
Take care not apply the
grease to the belt.

(Step 2)
Upset the CD
loading unit.

(Step 3)
Unsolder the
plunger terminals
(2 points).

(Step 4)
Unsolder the
plunger terminals
(2 points).

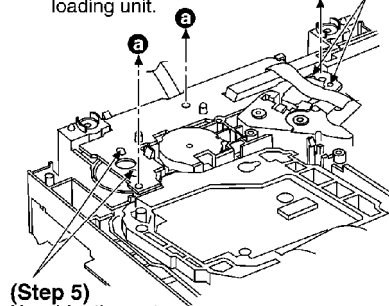

(Step 5)
Unsolder the motor
terminals (2 points).

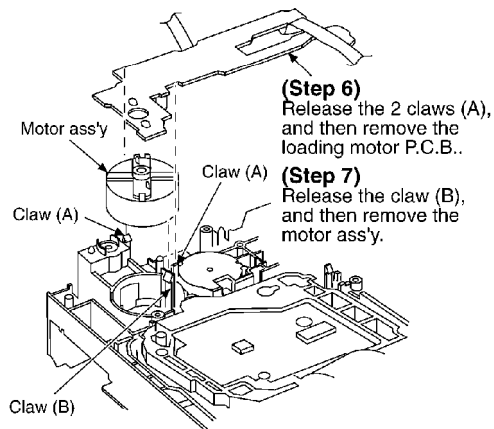

Notice for motor ass'y installation

1. Locate the name plate of motor to the traverse ass'y.
2. Align the hole of motor with the ribs.

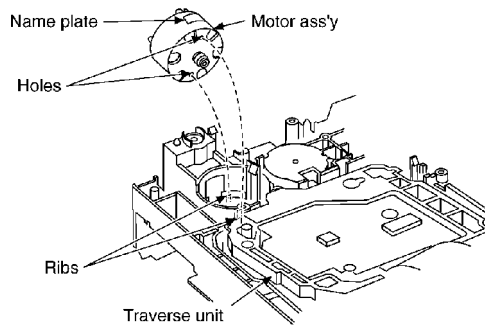

5.9. Replacement for the optical pick-up

- Follow the (Step 1) - (Step 3) of item 5.1.
- Follow the (Step 1) - (Step 5) of item 5.2.
- Follow the (Step 1) - (Step 11) of item 5.5.

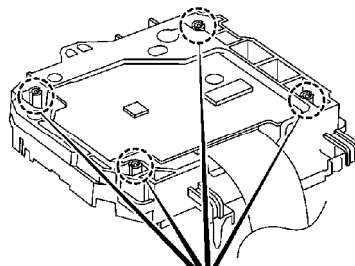

- (Step 1)**
Release the 2 claws, and
the pull out the fixed pin.

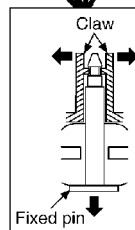

(Step 2)
Remove the traverse deck unit.

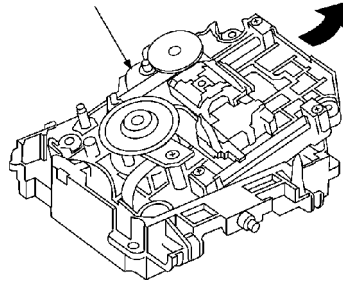

(Step 3)

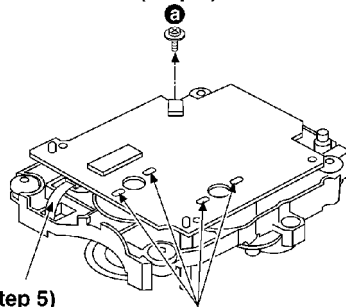

(Step 5)
Remove the FFC.

(Step 4)
Unsolder the motor terminals.

(Step 7)
Pull out the FFC from connector.

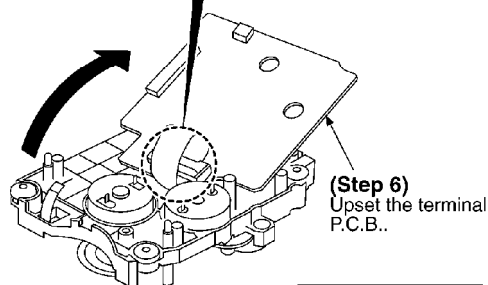
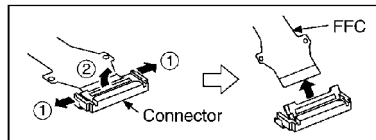

(Step 6)
Upset the terminal P.C.B..

Caution:
Insert short pin into the traverse unit FFC board.
(Refer to "Handling Precautions for Traverse Deck".)

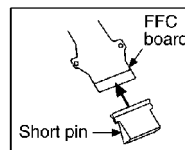

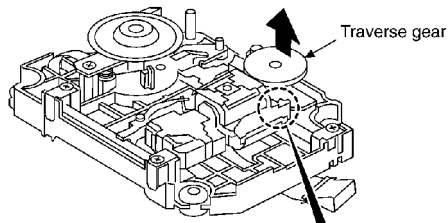

(Step 8)
Release the claws, and then pull out the traverse gear.



(Bottom side)

(Step 9)

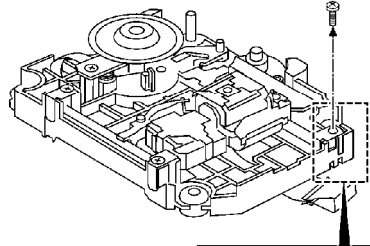

(Step 10)
Release the claw, and then remove the adjust spring holder.

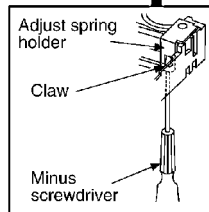

(Step 12)
Lift up the optical pick-up ass'y, and then remove the guide shaft (1) from the guide A.

(Step 11)
Remove the adjust spring.

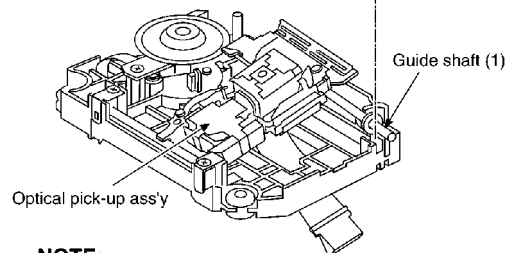

NOTE:
Take care not to lose the adjust spring.

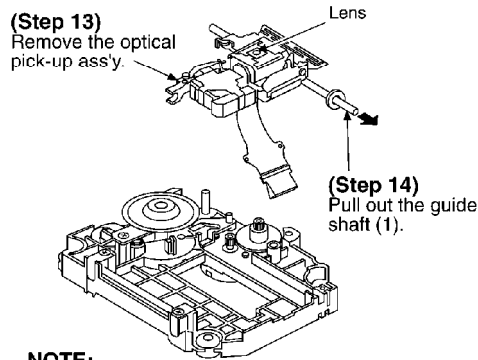

NOTE:

1. Use care to prevent damage the optical pick-up, due to the precision construction.
2. Do not touch the lens of the optical pick-up.

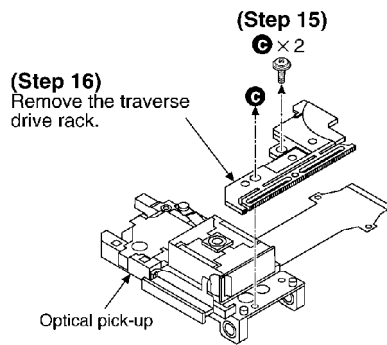

Installing the optical pick-up

(Step 3)
Install the tip end of guide shaft (1) to the hole of guide B.

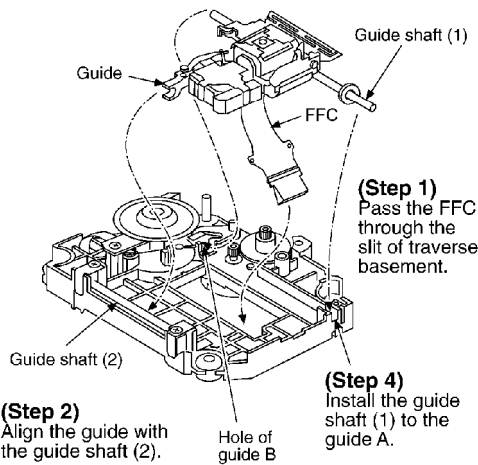

6. Optical Pickup Self-Diagnosis and Replacement Procedure

6.1. Self-diagnosis

The optical pickup self-diagnosis function and tilt adjustment check function have been included in this unit. When repairing, use the following procedure for effective Self-diagnosis and tilt

adjustment. Be sure to use the self-diagnosis function before replacing the optical pickup when "NO DISC" is displayed. As a guideline, you should replace the optical pickup when the value of the laser drive current is more than 55.

Note:

Press the power button to turn on the power, and check the value within three minutes before the unit warms up. (Otherwise, the result will be incorrect.)

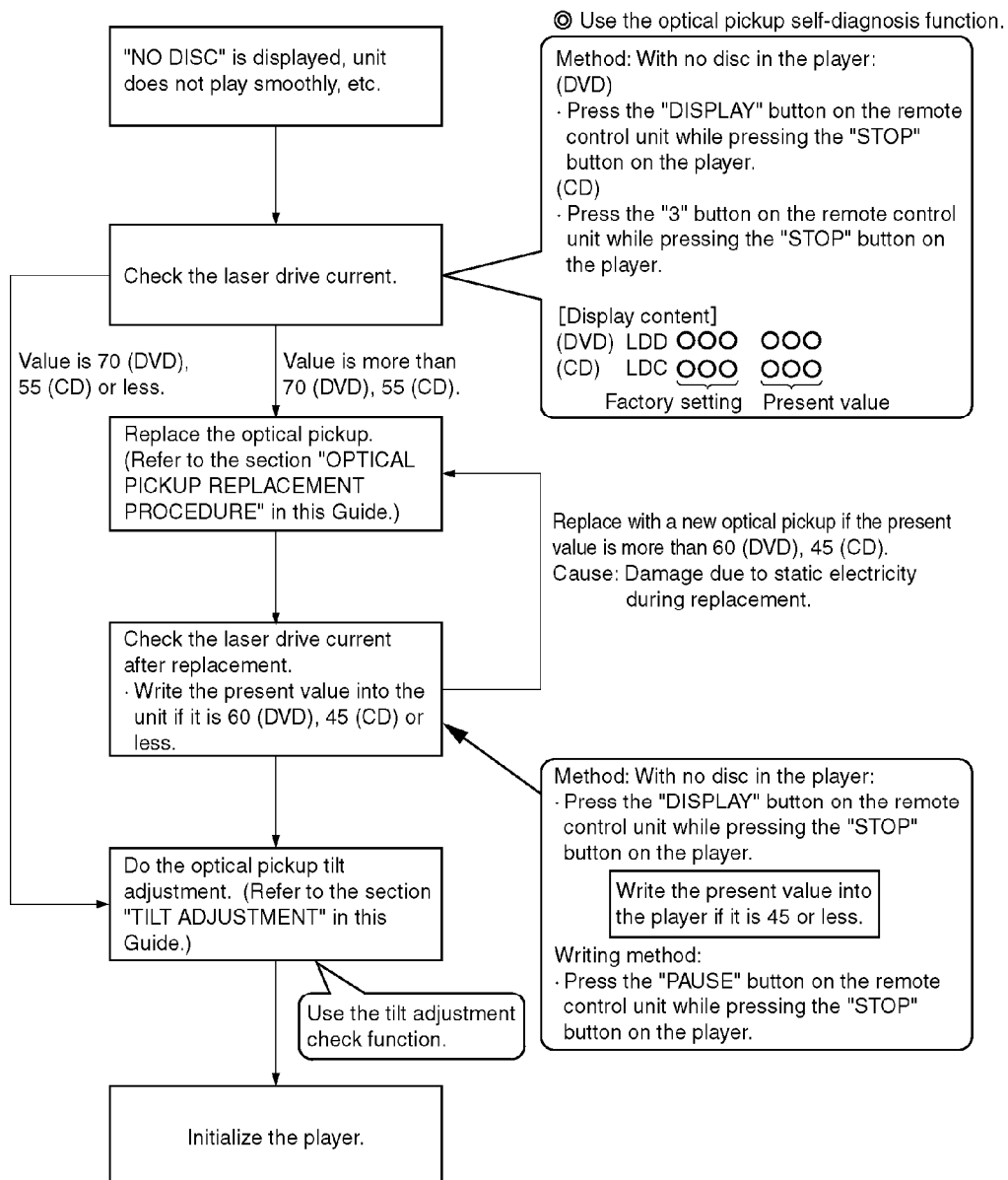

6.2. Cautions to Be Used Before Replacing the Optical Pickup Unit and Spindle Motor Assembly

Before replacing the optical pickup unit and spindle motor assembly, check the total using hours for each of them. The checking method is as follows:

	Operating state & Key operation	Display
Using hours of DVD and CD lasers	Press "STOP" button on the player, and "▲" on the remote control .	T1_xxxx_yyyy: total hours are displayed by 4-digit figures (unit: 10 hours).
Using hours of SP motor	Press "STOP" button on the player, and "▶" on the remote control.	T2_xxxx: total hours are displayed by 4-digit figures (unit: 10 hours).
Resetting using hours of DVD and CD lasers (Simultaneous resetting)	Press "STOP" button on the player, and "▼" on the remote control.	T1_0000_0000
Resetting using hours of the SP motor	Press "STOP" button on the player, and "◀" on the remote control .	T2_0000

Cautions to be taken when replacing the optical pickup

The optical pickup may break down due to the static electricity of human body. Take proper protection measures against static electricity before repairing the parts around the optical pickup.

- 1. Do not touch the areas around the laser diode and actuator.**
- 2. Do not judge the laser diode with a tester. (The tester will be damaged easily.)**
- 3. It is recommended to use a destaticized soldering iron for short-circuiting or removing the laser diode. (Recommended soldering iron) HAKKO ESD Product**
- 4. Solder the land of the flexible cable in the optical pickup.**

Note:

- When using a soldering iron which is not destaticized, short-circuit the terminal face of the flexible case with a clip. After that, short-circuit the land.**
- After the repairing work is completed, remove the solder according to the correct procedure shown in this Technical Guide.**

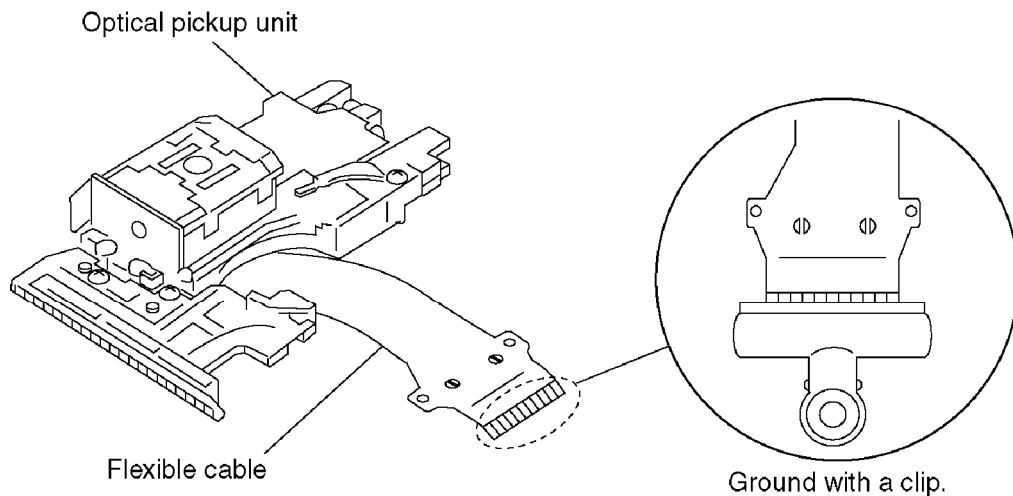

7. Self-Diagnosis Function and Service Modes

Each results of self-diagnostic function and service mode is displayed on the LCD of Tuner / Amplifier (SA-DV290). When using these function, confirm the unit to be connected by system cable.

7.1. Self-diagnostic function for loading mechanism

7.1.1. How to enter the mode and display

1. Turn on the power.
2. Press “SELECT” button on the Tuner / Amplifier (SA-DV290) to select DVD.
3. With no disc on the unit, hold down REPEAT button for at least 2 seconds, and then press ■(STOP) button for at least 2 seconds.
4. A loading mechanism error code is displayed if any. (No error is detected, “_ T_ ---” is displayed. _ indicates a space.) Refer to Table 7-1. If there are multiple error, they can be successively by pressing ►► / ►►(F-SKIP) button.

7.1.2. Canceling self-diagnostic function

- Press “Standby/on” button to turn off. And then press “Standby/on” button again to turn it on again.

7.1.3. Clearing self-diagnostic function



- After repairing, continue to press ■(STOP) button for at least 5 seconds in the situation of having displayed the error code. / (Clearing the contents of self-diagnostic function)
- Always be sure to clear memories after completing repair.

Table 7-1

Display code	Cause
H15	Disc tray open detect switch (S3) fault. / (Check and replace)
F16	Clamp switch (S4) fault. / (Check and replace)
F17	Bottom switch (S5) fault. / (Check and replace)
F27	Tray position detect switch (S1, S2) fault. / (Check and replace)
F28	Disc load error.
F29	Disc unload error.

7.2. Service mode table 1

Pressing various button combinations on the unit and remote control can activate the service modes.

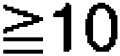
Unit button	Remote control button	Application
	0	Displaying the error code. (Refer to the item 7.3. "DVD/CD error display".)
	5	Jitter check, optical pick-up tilt adjustment.
	6	Checking the region numbers and broadcast system.
	7	Checking the program version.
	DISPLAY	Checking DVD laser drive current measurement.
	3	Checking CD laser drive current measurement.
		Writing the laser drive current value after replacing the optical p (Do not perform this mode except for replacing the optical pick-
		Initialization (Restore factory preset settings) / Perform this mode replacing the microcomputer, its peripheral parts and P.C.B..

7.3. DVD Self Diagnostic Function-Error Code

Error Code	Error Content	Additional error explanation	Defect 1	Defect 2	Defect 3
	U, H error				
U11	Focus error				
H01	Tray loading error				
H02	Spindle servo error	(Spindle servo, DSC SP motor, CLV servo error)			
H03	Traverse servo error				
H04	Tracking servo error				
H05	Seek error				
H06	Power error	Cannot switch off the power because of the panel and system computer communication error			
	DSC related				
F500	DSC error	DSC stops in the occurrence of servo error (startup, focus error, etc)	OPU	ADSC	FEP
F501	DSC not Ready	DSC-system computer communication error (Communication failure caused by idling of DSC)	ADSC	CPU	
F502	DSC Time out error	Similar disposal as F500	OPU	ADSC	FEP
F503	DSC communication Failure	Communication error (result error occurred although communication command was sent)	ADSC	FEP	EEPROM
F505	DSC Attention error	Similar disposal as F500	OPU	ADSC	FEP
F506	Invalid media	Disc is flipped over, TOC unreadable, incompatible disc	DISC	FEP	ADSC
	ODC related				
F600	Access failure to management information caused by demodulation error	Operation stopped because navigation data is not accessible caused by the demodulation defect	ODC	FEP	ADSC
F601	Indeterminate sector ID requested	Operation stopped caused by the request to access abnormal ID data	ODC	FEP	ADSC
F602	Access failure to LEAD-IN caused by demodulation error	LEAD IN data unreadable			

Error Code	Error Content	Additional error explanation	Defect 1	Defect 2	Defect 3
F603	Access failure to KEYDET caused by demodulation error	Access failure to CSS data of disc			
F610	ODC abnormality	No permission for command execution	ODC		
F611	6626 QCODE don't read Error	Access failure to seek address in CD series	ODC		
F612	No CRC OK for a specific time	Access failure to ID data in DVD series	ODC		
F630	No reply to KEY DET enquiry	(for internal use only)			
F631	CPPM KEY DET is not available till the FILE terminal	(CPPM file system is unreadable caused by scratches)	DISC	CPPM	
F632	CPPM KEY DET is not available	Been revoked or falsified	DISC	EEPROM	CPPM
	Disc code				
F103	Illegal highlight Position	Big possibility of disc specification violation during highlight display	DISC		
	HIC Error				
F4FF	Force initialize failure (time out)		EEPROM	CPU	FEP
	Micro computer error				
F700	MBX overflow	When replying message to disc manager			
F701	Message command does not end	Next message is sent before replying to disc manager			
F702	Message command changes	Message is changed before it is sent as a reply to disc manager			
F880	Task number is not appropriate	Message coming from a non-existing task			
F890	Sending message when message is being sent to AV task	Sending message to AV task			
F891	Message couldn't be sent to AV task	Begin sending message to AV task			
F893	FROM falsification		FROM	CPU	

Error Code	Error Content	Additional error explanation	Defect 1	Defect 2	Defect 3
F894	EEPROM abnormality		EEPROM	Serial / communication on lone	
F8A0	Message command is not appropriate	Begin sending message to AV task			

7.4. Last Error Code saved during NO PLAY

Error code	Error Content	System computer	Setting task	System computer i error code
F0BF	6) Cannot playback because physical layer is not recognizable	PCND_NOPLAY PHYSICAL 0x50	DriveManager	0xDOBF
F0C0	8) DVD: Cannot playback because it is not DVD Video /Adio/VR	PCND_NOPLAY VIDEO 0x70	DiscManager	0xDOC0
F0C1	9) DVD: Prohibited by the restricted region code	PCND_NOPLAY RCD 0x80	DiscManager	0xDOC1
F0C2	A) DVD: PAL restricted playback	PCND_NOPLAY PAL 0x90	DiscManager	0xDOC2
F0C3	B) DVD: Parental lock setting prohibits the playback of the entire title	PCND_NOPLAY PTL 0xA0	DiscManager	0xDOC3
F0C4	C) VCD: Prohibited because it is in PHOTO CD fromat	PCND_NOPLAY PHOTO CD 0xB0	DiscManager	0xDOC4
F0C5	VCD/CD: Prohibited because it is CDROM without CD-DA	PCND_NOPLAY CDROM 0xC0	DiscManager	0xDOC5

7.5. Service mode table 2

Pressing various button combinations on the player and remote control unit can activate the service modes.

Item	Play mode and button combination	Function	Display	Cancellation method
Jitter check	In PLAY mode, press "STOP" button on the player, and "5" button on the remote control unit.	Jitter check Jitter rate is measured and displayed. Measurement is repeatedly done in the cycle of one second. Read error counter starts from zero upon mode setting. When target block data failed to be read out, the counter advances by one increment. When the failure is caused by minor error, it may be corrected when retried to enable successful reading. In this case, the counter advances by one. When the error persists even after retry, the counter may jump by two or more.	J _xxx_yyy_zz ↑ ↑ ↑ Focus drive value Read error counter Jitter rate Jitter check mode Jitter rate is shown in decimal notation to one place of decimal. Focus drive value is shown in hexadecimal notation.	Press STOP button.
Error code check	Press "STOP" button on the player, and "0" button on the remote control unit.	Error code check The latest error code stored in EEPROM is displayed.	Error code (play_err) is expressed in the following convention. Error code = 0 x DAXX is expressed: → DVD UXX Error code = 0 x DBXX is expressed: → DVD HXX Error code = 0 x DXXX is expressed: → DVD FXXX Error code = 0 x 0000 is expressed: → DVD FXXX	Cancelled automatically 5 seconds later.
Initial setting of laser drive current	In STOP mode, press "STOP" button on the player, and "PAUSE" button on the remote control unit.	Initial setting of laser drive current. Initial current value for each of DVD laser and CD laser is separately saved in EEPROM.	LDO_034_028 ↑ ↑ ↑ CD laser current measurement DVD laser current measurement Laser current measurement mode	Cancelled automatically 5 seconds later.
DVD laser drive current measurement	In STOP mode, press "STOP" button on the player, and "DISPLAY" button on the remote control unit.	DVD laser drive current measurement DVD laser drive current is measured and the result is displayed together with the initial value stored in EEPROM. After the measurement, DVD laser emission is kept on. It is turned off when POWER key is switched off. (It is also turned off when the primary power is switched off.)	LDD_034_032 ↑ ↑ ↑ Measured current Initial current stored in EEPROM DVD laser current measurement mode The value denotes the current in decimal notation. The above example shows the initial current is 34mA and the measured value is 32mA.	Cancelled automatically 5 seconds later.
ADSC internal RAM data check	Press "STOP" button on the player, and "1" button on the remote control unit.	ADSC internal RAM data check ADSC internal RAM data is read out and displayed. Change the address with "CANCEL" key operation to show the data for 14 addresses.	A_DFA_6901 ↑ ↑ ↑ RAM data for specified address Address ADSC internal RAM data check mode The value is shown in hexadecimal notation. The above example shows the data in ADSC address DFAh is 6901h.	Press STOP button.
CD laser drive current measurement	In STOP mode, press "STOP" button on the player, and "3" button on the remote control unit.	CD laser drive current measurement CD laser drive current is measured and the result is displayed together with the initial value stored in EEPROM. After the measurement, CD laser emission is kept on. It is turned off when POWER key is switched off. (It is also turned off when the primary power is switched off.)	LDC_028_026 ↑ ↑ ↑ Measured current Initial current stored in EEPROM CD laser current measurement mode The value denotes the current in decimal notation. The above example shows the initial current is 28mA and the measured value is 28mA.	Cancelled automatically 5 seconds later.

Item	Play mode and button combination	Function	Display	Cancellation method
Version display	In STOP mode, press "STOP" button on the player, and "7" button on the remote control unit.	Version display		Cancelled automatically 5 seconds later.
Dealer's lock	In STOP mode, press "STOP" on the player, and "PLAY" button on the remote control unit for 3 second.	Dealer's lock The lock is switched ON or OFF. When dealer's lock is ON, it prohibits the tray opening. When the lock is switched, its ON/OFF status is stored in EEPROM.	<p>· "LOCKED" sign appears when dealer's lock is switched on, or when secondary power key or tray opening key is pressed while the lock is on.</p> <p>· "UNLOCKED" sign appears when dealer's lock is switched off.</p>	Repeat the same operation.
Initialization	In STOP mode, press "STOP" button on the player and "≥10" button on the remote control unit.	Initialization User settings are cancelled and player is initialized to factory setting.	"INITIALIZED"	
Region display	In STOP mode, press "STOP" button on the player, and "6" button on the remote control unit.	Region display		Cancelled automatically 5 seconds later.
Timer 1 check	In STOP mode, press "STOP" button on the player, and "▲" button on the remote control unit.	Timer 1 check Operation time of laser operation timer is measured separately for DVD laser and CD laser.	T1_1234_5678 Shown to the left is DVD laser time, and to the right CD laser time. Time is shown in 4 digits of decimal notation in a unit of 10 hours. "0000" will follow "9999".	Cancelled automatically 5 seconds later.
Timer 1 reset	While displaying Timer 1 data, press "STOP" button on the player, and "▼" button on the remote control unit.	Timer 1 reset Operation time of laser operation timer of both DVD laser and CD laser is reset all at once.	T1_0000_0000	Cancelled automatically 5 seconds later.
Timer 2 check	In STOP mode, press "STOP" button on the player, and "▶" button on the remote control unit.	Timer 2 check Spindle motor operation timer	T2_1234 Time is shown in 4 digits of decimal notation in a unit of 10 hours. "0000" will follow "9999".	Cancelled automatically 5 seconds later.
Timer 2 reset	While displaying Timer 2 data, press "STOP" button on the player, and "◀" button on the remote control unit.	Timer 2 reset Spindle motor operation timer	T2_0000	Cancelled automatically 5 seconds later.

7.6. Sales demonstration lock function

This function prevents discs from being lost when the unit is used for sales demonstrations by disabling the disc eject function. "LOCKED" is displayed on the unit, and ordinary operation is disabled.

7.6.1. Setting

The sales demonstration lock is set by simultaneously pressing "STOP" button on the player and "PLAY" button on the remote control unit.

7.6.2. Cancellation

The lock can be cancelled by the same procedure as used in setting. ("UNLOCKED" is displayed on cancellation. Disconnecting the power cable from power outlet does not cancel the lock.)

7.7. Handling After Completing Repairs

Use the following procedure after completing repairs.

7.7.1. Method

Confirm that the power is turned on:

1. Press the "OPEN/CLOSE" button to close the tray.
2. Press the "POWER" button to turn off the power.
3. Disconnect the power plug from the outlet.

7.7.2. Precautions

Do not disconnect the power plug from the outlet with the tray still open, then close the tray manually.

8. Service Precautions

8.1. Recovery after the DVD player is repaired

- When a FROM or module P.C.B. is replaced, carry out the recovery processing to optimize the drive.

Playback the recovery disc to process the recovery automatically.

- Recovery disc (Product number: RFKZD5TR006 or RFKZD03R004)

- Performing recovery

1. Load the recovery disc (RFKZD5TR006 or RFKZD03R004) on to the unit and run it.
2. Recovery is performed automatically. When it is finished, a message appears on the screen.
3. Remove the recovery disc.
4. Turn off the power.

Note:

This unit requires no initialization process carried out after the traditional DVD players were repaired.

When the recovery measure are taken, the customer setting will return to the factory preset settings as same as the procedure described in item of "Initialization" in 7.6. is carried out. Write down the contents of the setting before recovery processing, and reset the unit.

8.2. Firmware version-up of the DVD player

- The firmware of the DVD player may be renewed to improve the quality including operability and playback ability to the substandard discs processing to optimize the drive.

The recovery disc has also firmware version-up.

- After version-up, recovery processing is executed automatically.

- Part number of the recovery disc for version-up will be noticed when it is supplied.

- Updating firmware

1. Load the recovery disc that is supplied to the unit and run it.
2. Firmware version of the unit is automatically checked.
Appropriate message appears whenever necessary.
3. Using remote control cursor key, select whether version updating is to be done or not. (Selection of Yes/No)
4. a. If Yes is selected, version updating is performed.

- b. If No is selected, only recovery is performed.
- 5. a. When updating is finished, remove the disc according to the message appearing on the screen.
b. Remove the disc according to the message appearing on the screen.
- 6. Turn off the power.

Note:

If the AC power supply is shut down during version-up due to a power failure, the version-up is improperly carried out.

In such a case, replace the FROM and carry out the version-up again.

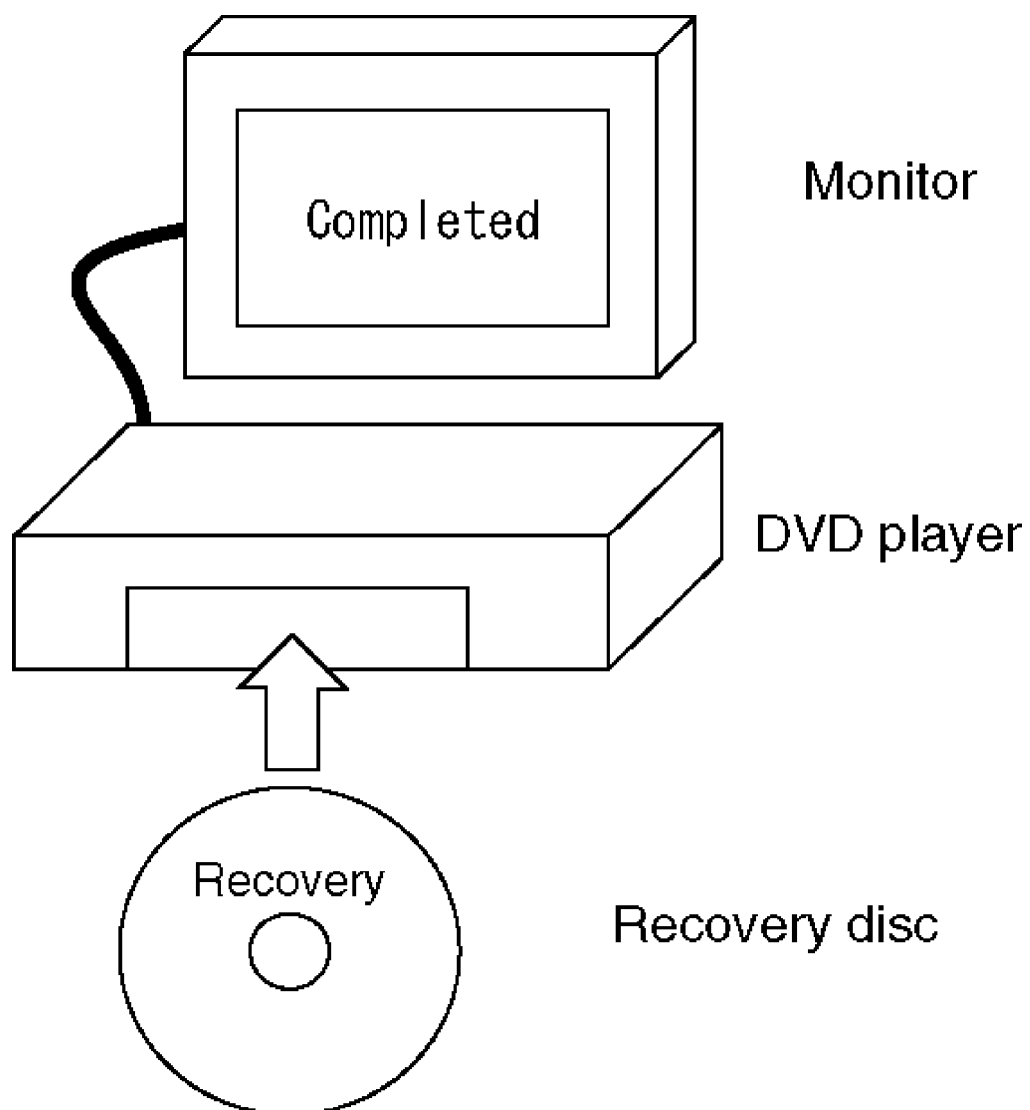

8.3. Overview of each function

8.3.1. Cumulative operation time display

1. Operation/display

T 1_0 1 2 3_0 1 2 3 DVD/CD laser operation time
Unit: 10 hours in decimal notation

T 2_0 1 2 3 Spindle motor operation time
Unit: 10 hours in decimal notation

Key operations are as follows.

Laser operation time In STOP mode, main unit [STOP]+ remote controller [▲]

Spindle motor operation time In STOP mode, main unit [STOP]+ remote controller [▶]

To reset the timer, perform the following while displaying the time with above key operation.

Laser operation time In STOP mode, main unit [STOP]+ remote controller [▼]

Spindle motor operation time In STOP mode, main unit [STOP]+ remote controller [◀]

2. How to utilize

Reference information in fault diagnosis of laser or spindle motor system

Review of faulty point in repeated repair

9. Adjustment Procedures

9.1. Service Tools and Equipment

Application	Name	Number
Tilt adjustment	DVD test disc	DVDT-S15 or DVDT-S01
	Hex wrench	Commercially available hex wrench
Others	Screw lock	RZZ0L01
	Grease	RFKXGAK152
	Oil	RFKXGA1280, JZS0648
Confirmation	CD test disc	PVCD-K06 or any other commercially available disc
	VCD test disc	PVCD-K06 or any other commercially available disc
	Recovery disc	RFKZD5TR006 or RFKZD03R004

9.2. Important points in adjustment

9.2.1. Important points in optical adjustment

- Before starting optical adjustment, be sure to take anti-static measures.
- Optical pickup tilt adjustment is needed after replacement of the following components.

1. Optical pickup unit
2. Spindle motor unit
3. Optical pickup peripheral parts (such as rail)

Notes

Adjustment is generally unnecessary after replacing other parts of the traverse unit. However, make adjustment if there is a noticeable degradation in picture quality. Optical adjustments cannot be made inside the optical pickup. Adjustment is generally unnecessary after replacing the traverse unit.

9.2.2. Important points in electrical adjustment

- Follow the adjustment procedures described in this Manual.

9.3. Storing and Handling Test Discs

- Surface precision is vital for DVD test discs. Be sure to store and handle them carefully.
1. Do not place discs directly onto the workbench, etc., after use.
 2. Handle discs carefully in order to maintain their flatness. Place them into their case after use and store them vertically. Store discs in a cool place where they are not exposed to direct sunlight or air from air conditioners.
 3. Accurate adjustment will not be possible if the disc is warped when placed on a surface made of glass, etc. If this happens, use a new test disc to make optical adjustments.
 4. If adjustment is done using a warped disc, the adjustment will be incorrect and some discs will not be playable.

9.4. Optical adjustment

9.4.1. Optical pickup tilt adjustment

Measurement point	Adjustment point	Mode	Disc
	Tangential adjustment screw	T01 (inner periphery) play	DVDR-S15 or DVD
	Tilt adjustment screw	T43 (outer periphery) play	
Measuring equipment		Adjustment value	
None (Main unit display for servicing is used.)		Adjust to the minimum jitter value.	

9.4.1.1. Adjustment procedure

- 1. While pressing "STOP" button on the main unit, press "5" on the remote control unit.**
- 2. Confirm that "J_xxx_yyy_zz" is shown on the front display.**

For your information:

"yyy" and "zz" shown to the right have nothing to do with the jitter value. "yyy" is the error counter, while "zz" is the focus drive value.

Note:

Jitter value appears on the front display.

- 3. Play test disc T01 (inner periphery).**
- 4. Adjust tangential adjustment screw so that the jitter value is minimized.**
- 5. Play test disc T43 (outer periphery).**
- 6. Adjust tilt adjustment screw 1 so that the jitter value is minimized.**
- 7. Play test disc T43 (outer periphery).**
- 8. Adjust tilt adjustment screw 2 so that the jitter value is minimized.**
- 9. Repeat adjusting tilt adjustment screws 1 and 2 alternately until the jitter value is minimized.**

9.4.1.2. Important points

- 1. Make tangential adjustment first, and then make tilt adjustment.**
- 2. Repeat adjusting two or three times to find the optimum point.**
- 3. Finish the procedure with tilt adjustment.**

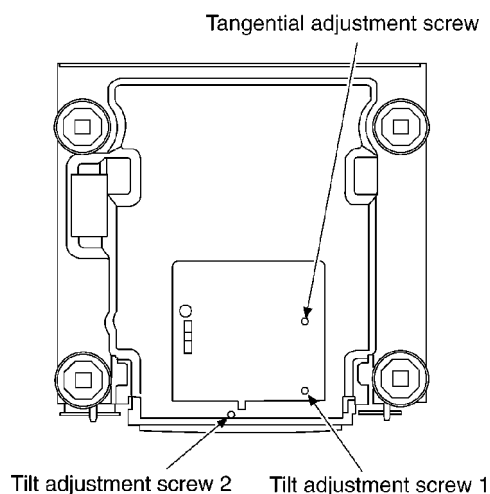
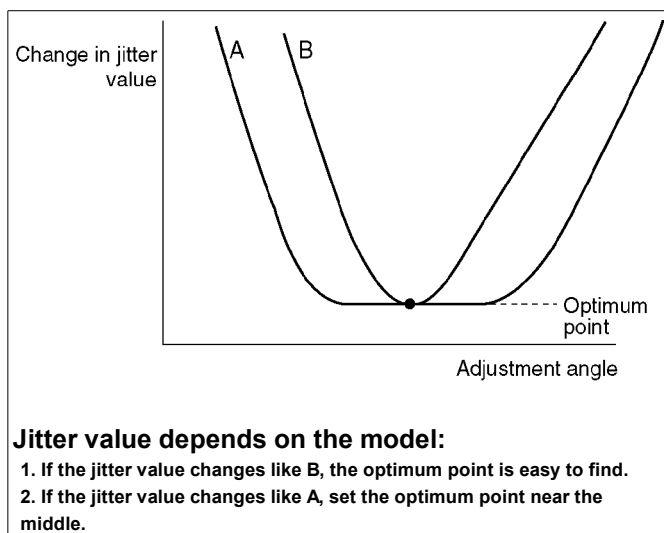

9.4.1.3. Check after adjustment

Play test disc or any other disc to make sure there is no picture degradation in the inner, middle and outer peripheries, and no audio skipping. After adjustment is finished, lock each adjustment screw in position using screw lock.

9.4.1.4. Procedure for screw lock

1. After adjustment, remove top cover, tray, clamper base and traverse unit in this sequence.
2. Lay the traverse unit upside down, and fix adjustment screw with screw lock.
3. After fixing, reassemble traverse unit, clamper base, tray and top cover.

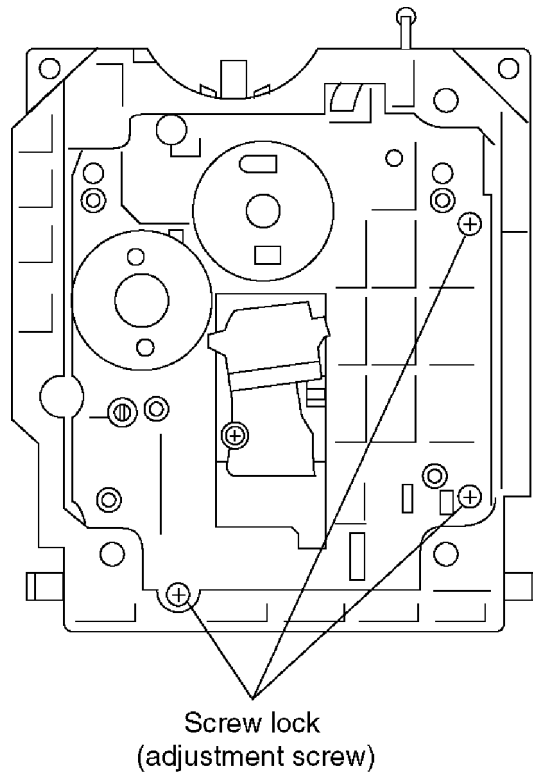

10. To Supply Power Source

Cautions:

- It is very dangerous to look at or touch the laser beam. (Laser radiation is invisible.)

With the unit turned “on”, laser radiation is emitted from the pickup lens.

- Avoid exposure to the laser beam, especially when performing adjustments.

This unit SL-DV290 is designed to operate on power supplied from the system connected. (For system connection, refer to Fig. 4.)

Fig. 4

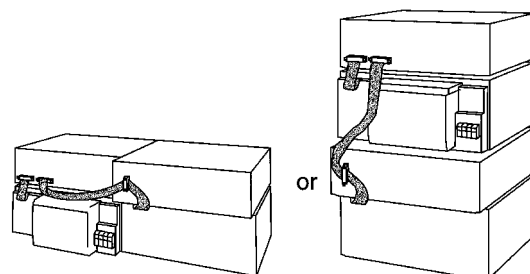

When the unit SL-DV290 has to test and service alone, use the following method to supply power source.

1. Connect a DC power supply to JK1-5pin and JK1-6pin and .
Then adjust the outputs to 10V for 5pin (refer to Fig. 5 and Fig. 6)

Fig. 5

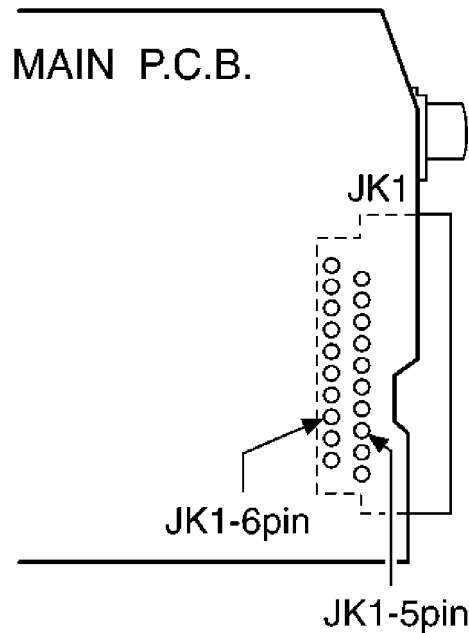
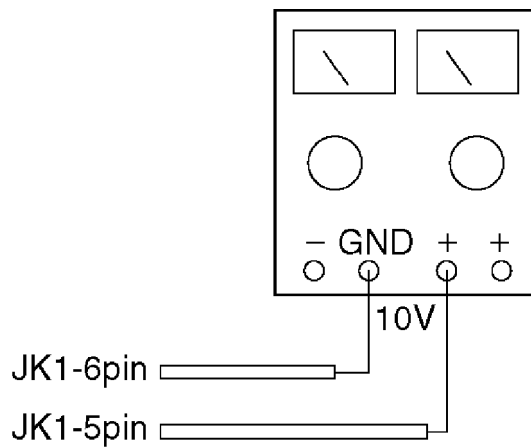

Fig. 6



Note:

Use only this method when checking the voltage etc..

In case of checking operations, use the system connections to supply power source.

11. Block Diagram









12. Schematic Diagram Notes

12.1. Type Illustration of IC's, Transistors and Diodes

12.2. Schematic Diagram Notes

This schematic diagram may be modified at any time with the development of new technology.

Notes:

- S1 : Tray position 1 detect switch.
- S2 : Tray position 2 detect switch.
- S3 : Tray open detect switch.
- S4 : Clamp detect switch.
- S5 : Bottom detect switch.
- S601 : Disc select (DISC5) switch.
- S602 : Disc select (DISC4) switch.
- S603 : Disc select (DISC3) switch.
- S604 : Disc select (DISC2) switch.
- S605 : Disc select (DISC1) switch.
- S606 : Disc direct open (DIRECT OPEN, DISC1) switch.
- S607 : Disc direct open (DIRECT OPEN, DISC2) switch.
- S608 : Disc direct open (DIRECT OPEN, DISC3) switch.
- S609 : Disc direct open (DIRECT OPEN, DISC4) switch.
- S610 : Disc direct open (DIRECT OPEN, DISC5) switch.
- S611 : Disc tray open/close (, OPEN/CLOSE) switch.
- S612 : A-B repeat (A-B REPEAT) switch.
- S613 : Repeat (REPEAT) switch.
- S614 : CD edit (CD EDIT) switch.
- S615 : Cinema mode (CINEMA MODE) switch.
- S616 : Double re-master (DOUBLE RE-MASTER) switch.
- S617 : Pause () switch.
- S618 : Stop () switch.
- S619 : Play () switch.
- S620 : R. skip/search ( / ) switch.
- S621 : F. skip/search ( / ) switch.
- Indicated voltage values are the standard values for the unit measured by the DC electronic circuit tester (high-impedance) with the chassis taken as standard. Therefore, there may exist some errors in the voltage values, depending on the internal impedance of the DC circuit tester.

No mark: CD STOP

(): CD play [1kHz, L+R, 0dB]

Important safety notice:

Components identified by  mark have special characteristics important for safety. Furthermore, special parts which have purpose of fire-retardant (resistors), high-quality sound (capacitors), low-noise (resistors), etc. are used. When replacing any of components, be sure to use only manufacture's specified parts shown in the parts list.

Caution!

- IC and LSI are sensitive to static electricity.
- Secondary trouble can be prevented by taking care during repair.
- Cover the parts boxes made of plastics with aluminum foil.
- Ground the soldering iron.
- Put a conductive mat on the work table.
- Do not touch the legs of IC or LSI with the fingers directly.

Voltage and signal lines

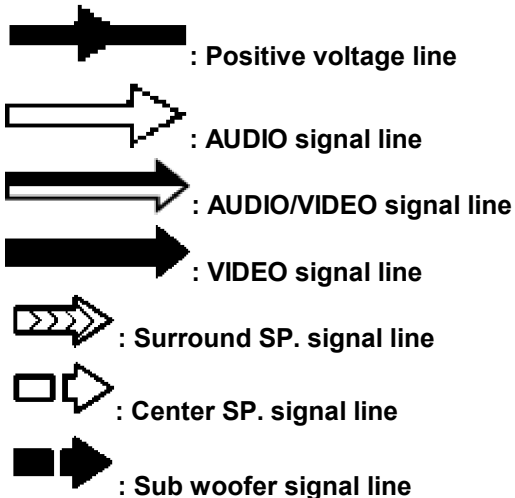

13. Schematic Diagram

14. Abbreviations

INITIAL/LOGO		ABBREVIATIONS
A	A0~UP	ADDRESS
	ACLK	AUDIO CLOCK
	AD0~UP	ADDRESS BUS
	ADATA	AUDIO PES PACKET DATA
	ALE	ADDRESS LATCH ENABLE
	AMUTE	AUDIO MUTE
	AREQ	AUDIO PES PACKET REQUEST
	ARF	AUDIO RF
	ASI	SERVO AMP INVERTED INPUT
	ASO	SERVOAMPOUTPUT
	ASYNC	AUDIOWORDDISTINCTION SYNC
B	BCK	BIT CLOCK (PCM)
	BCKIN	BIT CLOCK INPUT
	BDO	BLACK DROP OUT
	BLKCK	SUB CODE BLOCK CLOCK
	BOTTOM	CAP. FOR BOTTOM HOLD
	BYP	BYPATH
	BYTCK	BYTE CLOCK
C	CAV	CONSTANT ANGULAR VELOCITY
	CBDO	VELOCITY
	CD	CAP. BLACK DROP OUT
	CDSCK	COMPACT DISC
	CDSRDATA	CD SERIAL DATA CLOCK
		CD SERIAL DATA
	CDRF	CD RF (EFM) SIGNAL
	CDV	COMPACT DISC-VIDEO
	CHNDATA	CHANNEL DATA
	CKSL	SYSTEMCLOCKSELECT
	CLV	CONSTANTLINEARVELOCITY
	COFTR	CAP. OFF TRACK
	CPA	CPU ADDRESS
	CPCS	CPU CHIP SELECT
	CPDT	CPU DATA
	CPUADR	CPU ADDRESS LATCH
	CPUADT	CPU ADDRESS DATA BUS
	CPUIRQ	CPU INTERRUPT REQUEST
	CPRD	CPU READ ENABLE
	CPWR	CPU WRITE ENABLE
	CS	CHIPSELECT
	CSYNCIN	COMPOSITESYNCIN
	CSYNCOUT	COMPOSITESYNC OUT

INITIAL/LOGO		ABBREVIATIONS
D	DACCK	D/A CONVERTER CLOCK
	DEEMP	DEEMPHASIS BIT ON/OFF
	DEMPH	DEEMPHASIS SWITCHING
	DIG0~UP	FL DIGIT OUTPUT
	DIN	DATA INPUT
	DMSRCK	DM SERIAL DATA READ CLOCK
	DMUTE	
	DO	DIGITAL MUTE CONTROL
	DOUT0~UP	DROPOUT
		DATAOUTPUT
	DRF	DATASLICERF (BIAS)
	DRPOUT	DROP OUT SIGNAL
	DREQ	DATA REQUEST
	DRESP	DATA RESPONSE
	DSC	DIGITAL SERVO CONTROLLER
DSLRF	DATA SLICE LOOP FILTER	
DVD	DIGITAL VIDEO DISC	

INITIAL/LOGO		ABBREVIATIONS
E	EC	ERROR TORQUE CONTROL
	ECR	ERROR TORQUE CONTROL REFERENCE
	ENCSEL	ENCODER SELECT
	ETMCLK	EXTERNAL M CLOCK (81MHz/40.5MHz)
	ETSCLK	EXTERNAL S CLOCK (54MHz)
F	FBAL	FOCUS BALANCE
	FCLK	FRAME CLOCK
	FE	FOCUS ERROR
	FFI	FOCUS ERROR AMP INVERTED INPUT
	FEO	FOCUS ERROR AMP OUTPUT
	FG	FREQUENCY GENERATOR
	FSC	FREQUENCY SUB CARRIER
	FSCK	FS (384 OVER SAMPLING)CLOCK
G	GND	COMMON GROUNDING (EARTH)
H	HA0~UP	HOST ADDRESS
	HD0~UP	HOST DATA
	HINT	HOST INTERRUPT
	HRXW	HOST READ/WRITE

INITIAL/LOGO		ABBREVIATIONS
I	IECOUT IPFRAG IREF ISEL	IEC958 FORMAT DATA OUTPUT INTERPOLATION FLAG I (CURRENT) REFERENCE INTERFACE MODE SELECT
L	LDON LPC LRCK	LASER DIODE CONTROL LASER POWER CONTROL L CH/R CH DISTINCTION CLOCK
M	MA0~UP MCK MCKI MCLK MDATA MDQ0~UP MDQM MLD MPEG	MEMORY ADDRESS MEMORY CLOCK MEMORY CLOCK INPUT MEMORY SERIAL COMMAND CLOCK MEMORY SERIAL COMMAND DATA MEMORY DATA INPUT/OUTPUT MEMORY DATA I/OMASK MEMORYSERIALCOMMANDLOAD MOVING PICTURE EXPERTS GROUP
O	ODC OFTR OSCI OSCO OSD	OPTICAL DISC CONTROLLER OFF TRACKING OSCILLATOR INPUT OSCILLATOR OUTPUT ON SCREEN DISPLAY
P	P1~UP PCD PCK PDVD PEAK PLLCLK / PLLOK PWMCTL PWMDA PWMOA, B	PORT CD TRACKING PHASE DIFFERENCE PLL CLOCK DVD TRACKING PHASE DIFFERENCE CAP. FOR PEAK HOLD CHANNEL PLL CLOCK PLL LOCK PWM OUTPUT CONTROL PULSEWAVEMOTORDRIVEA PULSE WAVE MOTOR OUT A, B

INITIAL/LOGO		ABBREVIATIONS
R	RE	READ ENABLE
	RFENV	RF ENVELOPE
	RFO	RF PHASE DIFFERENCE
	RS	OUTPUT
	RSEL	(CD-ROM) REGISTER SELECT
	RST	RF POLARITY SELECT
	RSV	RESET RESERVE
S	SBI0, 1	SERIAL DATA INPUT
	SBO0	SERIAL DATA OUTPUT
	SBT0, 1	SERIAL CLOCK
	SCK	SERIAL DATA CLOCK
	SCKR	AUDIO SERIAL CLOCK
	SCL	RECEIVER
	SCLK	SERIAL CLOCK
	SDA	SERIAL CLOCK
	SEG0~UP	SERIAL DATA
	SELCLK	FL SEGMENTOUTPUT
	SEN	SELECTCLOCK
	SIN1, 2	SERIALPORTENABLE
	SOUT1, 2	SERIAL DATA IN
	SPDI	SERIAL DATA OUT
	SPDO	SERIAL PORT DATA INPUT
	SPEN	SERIAL PORT DATA OUTPUT
	SPRCLK	SERIAL PORT R/W ENABLE
	SPWCLK	SERIAL PORT READ CLOCK
	SQCK	SERIALPORT WRITE CLOCK
	SQCX	SUB CODE Q CLOCK
	SRDATA	SUBCODEQDATA READ CLOCK
	SRMADR	
	SRMDT0~7	SERIAL DATA SRAM ADDRESS BUS
	SS	SRAM DATA BUS 0~7
	STAT	START/STOP
	STCLK	STATUS
	STD0~UP	STREAM DATA CLOCK
	STENABLE	STREAM DATA STREAMDATA INPUT ENABLE
	STSEL	STREAM DATA POLARITY
	STVALID	SELECT
	SUBC	STREAMDATAVALIDITY
	SBCK	SUBCODE SERIAL
	SUBQ	SUB CODE CLOCK
SYSCLK	SUB CODE Q DATA SYSTEM CLOCK	

SYSTEM CLOCK		
INITIAL/LOGO		ABBREVIATIONS
T	TE	TRACKING ERROR
	TIBAL	BALANCE CONTROL
	TID	BALANCE OUTPUT 1
	TIN	BALANCE INPUT
	TIP	BALANCE INPUT
	TIS	BALANCE OUTPUT 2
	TPSN	OP AMP INPUT
	TPSO	OP AMP OUTPUT
	TPSP	OP AMP INVERTED INPUT
	TRCRS	TRACKCROSSIGNAL
	TRON	TRACKINGON
	TRSON	TRAVERSESERVO ON

INITIAL/LOGO		ABBREVIATIONS
V	VBLANK	V BLANKING
	VCC	COLLECTOR POWER SUPPLY VOLTAGE
	VCDCONT	VIDEO CD CONTROL (TRACKING BALANCE)
	VDD	DRAIN POWER SUPPLY VOLTAGE
	VFB	VOLTAGE REFERENCE
	VREF	VIDEO FEED BACK
	VSS	VOLTAGE REFERENCE
		SOURCEPOWERSUPPLYVOLTAGE
W	WAIT	BUS CYCLE WAIT
	WDCK	WORD CLOCK
	WEH	WRITE ENABLE HIGH
	WSR	WORD SELECT RECEIVER

INITIAL/LOGO		ABBREVIATIONS
X	X	X' TAL
	XALE	X ADDRESS LATCH ENABLE
	XAREQ	X AUDIO DATA REQUEST
	XCDROM	X CD ROM CHIP SELECT
	XCS	X CHIP SELECT
	XCSYNC	X COMPOSITE SYNC
	XDS	X DATA STROBE
	XHSYNCO	X HORIZONTAL SYNC OUTPUT
	XHINT	XHINTERRUPTREQUEST
	XI	X' TAL OSCILLATOR INPUT
	XINT	X INTERRUPT
	XMW	X MEMORY WRITE ENABLE
	XO	X' TAL OSCILLATOR OUTPUT
	XRE	X READ ENABLE
	XSRMCE	X SRAM CHIP ENABLE
	XSRMOE	X SRAM OUTPUT ENABLE
	XSRMWE	X SRAM WRITE ENABLE
	XVCS	XV-DEC CHIPSELECT
	XVDS	XV-DEC CONTROLBUS
	XVSYNCO	STROBE
		X VERTICAL SYNC OUTPUT

15. Printed Circuit Board Diagram

16. Wiring Connection Diagram

17. Terminal Function of IC's

17.1. IC401 (C2BBFD000402): SYSTEM CONTROL

Pin No.	Mark	I/O Division	Function
1	VCC	I	Connected to power supply
2	VREF		
3	AVSS	—	Connected to GND
4	MUTE	O	Mute control output terminal
5	PWCONT	O	DVD module power supply control output terminal
6	SYNC	I	Power failure detect signal input terminal
7	C/SW SEL	O	Center/sub woofer speaker select signal output terminal
8	B_REQ	I	Serial communication request signal input terminal
9	B_CS	O	Serial communication chip select signal output terminal
10	B_CLK	O	Serial communication clock signal output terminal
11	DATA O	O	Serial communication data signal output terminal
12	DATA I	I	Serial communication data signal input terminal
13	MIXSEL	O	Select control output terminal for wide picture
14	WIDE1		
15	CNVss	—	Connected to GND
16	TEST	I	Test mode input terminal
17	E-CS	—	Connected to GND
18	RESET	I	Reset signal input terminal
19	XIN	I	Crystal oscillator input terminal (f=8MHz)
20	XOUT	O	Crystal oscillator output terminal (f=8MHz)
21	Vss	—	Connected to GND
22	LED-STB	O	Serial signal output to LED drive
23	LED// E-CLK	O	Serial signal output terminal to LED drive or EEPROM
24	LED// E-DATA	O	Serial signal output terminal to LED drive or EEPROM
25	LED-CLR	O	Latch clear signal output terminal to LED drive
26	PLG	O	Plunger control signal output terminal
27	SW5	I	Bottom switch detect signal input terminal

Pin No.	Mark	I/O Division	Function
			input terminal
28	PSTN	I	Position sensor detect signal input terminal
29	SW2	I	Disc tray position 2 detect signal input terminal
30	SW1	I	Disc tray position 1 detect signal input terminal
31	SW3	I	Disc tray open detect signal input terminal
32	CCW	O	Motor drive control signal output terminal (forward direction)
33	CW	O	Motor drive control signal output terminal (reverse direction)
34	HALF	O	Motor drive control signal output terminal (speed)
35	DVD-CLK	I	Serial communication signal input terminal for DVD main micro-computer
36	DVD-CMD	O	Serial communication signal output terminal for DVD main micro-computer
37	DVD-STAT	I	Serial communication signal input for DVD main micro-computer
38	DISC CS	—	Connected to GND through resistor
39	SW4	I	Clamp switch detect signal input terminal
40	KEY2	I	Operation key signal input terminal
41	KEY1		
42	RGN CS	I	Area select signal input terminal

18. Replacement Parts List

Notes:

*Important safety notice: / Components identified by  mark have special characteristics important for safety. / Furthermore, special parts which have purposes of fire-retardant (resistors), high-quality sound (capacitors), low-noise(resistors), etc. are used. / When replacing any of components, be sure to use only manufacture's specified parts shown in the parts list. / *

Warning: This product uses a laser diode. Refer to caution statements.

*ACHTUNG: Die lasereinheit nicht zerlegen. Die lasereinheit darf nur gegen eine vom hersteller spezifizierte einheit ausgetauscht werden. / *Capacity values are in microfarads (uF) unless

specified otherwise, P=Pico-farads(pF)F=Farads(F) / *Resistance values are in ohms, unless specified otherwise, 1K=1,000 (OHM), 1M=1,000K (OHM)

*The markings (RTL) indicate that the retention time is limited for these items. After the discontinuation of these assemblies in production, it will no longer be available.

*All parts are supplied by SPC.

Ref. No.	Part No.	Part Name & Description	Pcs	Remarks
1	REZ1225-1J	FFC(14P)	1	
2	REZ1390-J	FFC(15P)	1	
3	REZ1391-J	FFC(17P)	1	
4	REZ1392-J	FFC(26P)	1	
5	RMX0210	SPACER	1	
6	RYF0592-1S	TRAY ORNAMENT	1	
7	RKA0105-K	RUBBER	4	
8	RKA0106-N	FOOT RING	4	
9	RYP1174-S1	FRONT PANEL ASS'Y	1	
9-1	RGB0025-A	TECHNICS BADGE	1	
10	XTB3+5JFZ	SCREW	2	
11	XTBS3+8JFZ1	SCREW	5	
12	XTW3+8T	SCREW	2	
13	RHD30007-1S	SCREW	4	
14	RKM0399-S1	TOP CABINET	1	
15	REZ1377-J	FFC(50P)	1	
16	RHD30090	SCREW	4	
17	REZ1314	FLAT CABLE	1	
18	RGR0315A-J1	REAR PANEL	1	(EE)
18	RGR0315A-K1	REAR PANEL	1	(GN)
19	RQLS0233	LASER CAUTION LABEL	1	
301	RML0517	TIMING LEVER	1	
302	RML0516	LEVER	1	
303	RMB0551	UPPER SPINDLE SPRING	1	
304	RMQ0744	LOWER HOOK	1	
305	RDV0056	BELT	1	
306	RML0525	FRONT LOCK LEVER	1	
307	RML0526	DISC LEVER	1	
308	RDG0424	DRIVE GEAR	1	
309	RDG0425	CHANGE GEAR	1	
310	RDG0427	TRAVERSE CAM GEAR	1	
311	RDG0428	TRAVERSE RELAY GEAR	1	
312	RDG0426	UP/DOWN GEAR	1	
313	RDG0429	PULLEY GEAR	1	
314	RMB0549-1	CHANGE GEAR SPRING	1	
315	RMQ0748	GEAR HOLDER	1	
316	RMB0553	SPRING	1	
317	RML0530	LEVER	1	
318	RML0518	CONNECTION LEVER	1	
319	RMM0201	SLIDE PLATE(1)	1	
320	RME0258	REAR LOCK SPRING	1	
321	RML0521	REAR LOCK LEVER	1	
322	RME0257	TRAY LOCK LEVER SPRING	1	
323	RML0520	TRAY LOCK	1	
324	RMM0202	SLIDE PLATE(2)	1	

Ref. No.	Part No.	Part Name & Description	Pcs	Remarks
325	XTB3+10J	SCREW	9	
326	RMR0624-W5	CLAMPER	1	
327	RMR1367-K	FIXED PLATE	1	
328	RMB0561	ASSIST LEVER SPRING	1	
329	RMR1121-K	MECHANISM COVER	1	
330	RMQ0742	SPINDLE BASE	1	
331	RXQ0561	DISC TRAY	1	
332	RME0261	FRONT LOCK SPRING	1	
333	RMX0140	DISC SPACER	5	
334	RHM0001	MAGNET	1	
335	RMQ0749	UPPER SPINDLE	1	
336	RMX0141	SPACER	1	
337	XTW3+10T	SCREW	4	
339	RXQ0595	MOTOR ASS'Y	1	
341	RSJ0003	SOLENOID	1	
342	RHM212ZD	MOVING CORE	1	
344	RML0519	CD LEVER	1	
346	RML0522	LOADING STOPPER	1	
347	RMQ0745	LOWER SPINDLE	1	
348	RMQ0746	UP/DOWN BASE	1	
349	RMB0550	LOWER SPINDLE SPRING	1	
350	RMQ0747	UPPER HOOK	1	
351	RME0263	SPRING	1	
352	RMQ0743	SPINDLE SHAFT	1	
353	RMB0552	CUSHION SPRING	1	
354	RDG0430	RELAY GEAR(A)	1	
355	RDG0431	RELAY GEAR(B)	1	
356	RME0262	DISC LEVER SPRING	1	
376	RMC0387	SUPPORT SPRING	1	
377	RMA1003	BACK YOKE	1	
378	XTV2+6G	SCREW	1	
401	RDG0499	TRAVERSE GEAR(A)	1	
402	RHD17045	SCREW	2	
404	RMC0415	ADJUST SPRING HOLDER	3	
407	RME0320	ADJUST SPRING	3	
408	RMM0234-1	TRV DRIVE RACK	1	
409	RMS0710-1	GUIDE SHAFT(1)	1	
410	RMS0711-1	GUIDE SHAFT(2)	1	
411	RDG0500	TRAVERSE GEAR(B)	1	
412	RDG0501	TRAVERSE GEAR(C)	1	
413	RME0319	TRAVERSE GEAR SPRING	1	
414	RAF3023A-1	OPTICAL PICK-UP	1	
415	RJB2308A-1	INTERFACE FPC	1	
417	RHD14095	SCREW	1	
418	VHD1224	SCREW	4	
419	RMX0192	INNER STOPPER	1	
420	RMG0561-T	CUSHION RUBBER	1	
422	RMG0545-A1	FLOATING RUBBER	4	
423	RXQ1028	SPINDLE MOTOR ASS'Y	1	
424	RMR1366-K1	TRAVERSE CHASSIS	1	
425	RMS0712-1	FIXED PIN	4	
428	RHD20060	SCREW	1	
429	RMG0558-K	RUBBER	4	





Ref. No.	Part No.	Part Name & Description	Pcs	Remarks
C1	ECEA1CKS101	16V 100U	1	
C2	ECBA1E103ZF5	25V 0.01U	1	
C3	ECA1CM332	16V 3300U	1	
C4	ECA1CM471	16V 470U	1	
C7	EEUFC0J821B	6.3V 820U	1	
C10	ECJ1VB1H102K	50V 1000P	1	
C11	ECEA1CKS100	16V 10U	1	
C12	ECJ1VB1H102K	50V 1000P	1	
C13	F1H1H103A748	50V 0.01U	1	
C14	ECEA1AKS101	10V 100U	1	
C15	ECEA1AKS221	10V 220U	1	
C16	ECA0JM222	6.3V 2200U	1	
C19	ECJ1VB1H102K	50V 1000P	1	
C20	ECEA1AKS470	10V 47U	1	
C21	ECJ1VB1H102K	50V 1000P	1	
C22	ECEA1CKS100	16V 10U	1	
C23	ECEA1AKS470	10V 47U	1	
C24	ECJ1VB1H102K	50V 1000P	1	
C26	ECEA1CKS100	16V 10U	1	
C27	F1J1C474A091	16V 0.47U	1	
C28	ECJ1VF1C104Z	16V 0.1U	1	
C29	F1H1H103A748	50V 0.01U	1	
C30	ECJ1VB1H102K	50V 1000P	1	
C80	F1H1H470A736	50V 47P	1	
C305	F1H1H103A748	50V 0.01U	1	
C308	ECEA1HKS010	50V 1U	1	
C401	F2A0J4700007	6.3V 47U	1	
C402	ECEA1HKS3R3	50V 3.3U	1	
C403	F1H1H103A748	50V 0.01U	1	
C404	ECJ1VB1H102K	50V 1000P	1	
C405	ECJ1VF1C104Z	16V 0.1U	1	
C406	EEAFC0J101B	6.3V 100U	1	
C407	F1H1H101A004	50V 100P	1	
C408,09	F1H1H471A736	50V 470P	2	
C410	F1H1H101A004	50V 100P	1	
C411,12	ECJ1VF1C104Z	16V 0.1U	2	
C501,02	F1H1H103A748	50V 0.01U	2	
C503,04	ECA1HAK010XI	50V 1U	2	
C505	F1H1H470A736	50V 47P	1	
C506,07	F1H1H103A748	50V 0.01U	2	
C508	ECA0JAK101XB	6.3V 100U	1	
C509	ECA0JAM102XB	6.3V 1000U	1	
C510	ECJ1VF1C104Z	16V 0.1U	1	
C511	ECA0JAK101XB	6.3V 100U	1	
C512	ECA0JAM102XB	6.3V 1000U	1	
C513,14	F1H1H103A748	50V 0.01U	2	
C515	ECA0JAK221XH	6.3V 220U	1	
C601-04	F1H1H101A004	50V 100P	4	
C605	ECJ1VF1C104Z	16V 0.1U	1	
C801,02	ECEA1CKS100	16V 10U	2	
C803,04	F1H1H471A736	50V 470P	2	
C806	F1H1H470A736	50V 47P	1	
C807	F2A0J4700007	6.3V 47U	1	
C808	ECJ1VF1C104Z	16V 0.1U	1	

Ref. No.	Part No.	Part Name & Description	Pcs	Remarks
C809,10	ECEA1CKS220	16V 22U	2	
C811,12	ECJ1VB1H222K	50V 2200P	2	
C813-16	ECEA1CKS100	16V 10U	4	
C817	ECJ1VF1C104Z	16V 0.1U	1	
C818	F2A0J4700007	6.3V 47U	1	
C819	ECEA1AKS101	10V 100U	1	
C821,22	ECEA1CKS100	16V 10U	2	
C823,24	F1H1H471A736	50V 470P	2	
C825,26	F1H1H470A736	50V 47P	2	
C827	F2A0J4700007	6.3V 47U	1	
C828	ECJ1VF1C104Z	16V 0.1U	1	
C829,30	F2A0J4700007	6.3V 47U	2	
C831,32	ECJ1VB1H222K	50V 2200P	2	
C833,34	F2A0J4700007	6.3V 47U	2	
C835,36	ECEA1CKS100	16V 10U	2	
C837,38	F1H1H471A736	50V 470P	2	
C839,40	F1H1H470A736	50V 47P	2	
C841	F2A0J4700007	6.3V 47U	1	
C842	ECJ1VF1C104Z	16V 0.1U	1	
C843,44	F2A0J4700007	6.3V 47U	2	
C845,46	ECJ1VB1H222K	50V 2200P	2	
C847-49	F2A0J4700007	6.3V 47U	3	
C892	ECJ1VF1C104Z	16V 0.1U	1	
C2001,02	EEEE0JA101SP	6.3V 100U	2	
C2003-18	ECJ1ZF1C104Z	16V 0.1U	16	
C2021	EEEE0JA101SP	6.3V 100U	1	
C2022-25	ECJ1ZF1C104Z	16V 0.1U	4	
C2031,32	ECJ1VB1C104K	16V 0.1U	2	
C2034	ECJ1VB1C393K	16V 0.039U	1	
C2035	ECJ1VB1H822K	50V 8200P	1	
C2036	ECJ1VB1C104K	16V 0.1U	1	
C2038	ECJ1VB1C104K	16V 0.1U	1	
C2039	ECJ1VB1H103K	50V 0.01U	1	
C2040	ECJ1VC1H102J	50V 1000P	1	
C2041,42	ECJ1VC1H331J	50V 330P	2	
C2043	ECJ1VC1H101J	50V 100P	1	
C2044	ECJ1VC1H391J	50V 390P	1	
C2045,46	ECJ1VC1H102J	50V 1000P	2	
C2047	ECJ1VB1H103K	50V 0.01U	1	
C2048	ECJ1VB1C153K	16V 0.015U	1	
C2050	ECJ1VB1C333K	16V 0.033U	1	
C2051	ECJ1VC1H680J	50V 68P	1	
C2052,53	ECJ1ZF1C104Z	16V 0.1U	2	
C2054	ECJ1VC1H681J	50V 680P	1	
C2055	ECJ1VB1H682K	50V 6800P	1	
C2056,57	ECJ1VB1H272K	50V 2700P	2	
C2058	ECJ1VC1H102J	50V 1000P	1	
C2059	ECJ1VC1H821J	50V 820P	1	
C2060	ECJ1VC1H102J	50V 1000P	1	
C2061,62	ECJ1VC1H331J	50V 330P	2	
C2063-65	ECJ1VC1H102J	50V 1000P	3	
C2066,67	ECJ1VB1H472K	50V 4700P	2	
C2073	ECJ1ZF1C104Z	16V 0.1U	1	
C2101,02	ECJ1ZF1C104Z	16V 0.1U	2	

Ref. No.	Part No.	Part Name & Description	Pcs	Remarks
C2501	EEVFC0J221P	6.3V 220U	1	
C2502	ECEV1CA101WP	16V 100U	1	
C2503	ECEV1CA220WR	16V 22U	1	
C2504-08	ECJ1VF1C104Z	16V 0.1U	5	
C2509	EEVFC1C100R	16V 10U	1	
C2510-13	ECJ1VF1C104Z	16V 0.1U	4	
C3001,02	F2G0J331A015	6.3V 330U	2	
C3003-18	ECJ1ZF1C104Z	16V 0.1U	16	
C3019	F1H0J1050013	6.3V 1U	1	
C3020	ECJ1ZF1C104Z	16V 0.1U	1	
C3021	F1H0J1050013	6.3V 1U	1	
C3022-36	ECJ1ZF1C104Z	16V 0.1U	15	
C3037	F2G0J331A015	6.3V 330U	1	
C3038,39	ECJ1ZF1C104Z	16V 0.1U	2	
C3051	ECJ1VC1H220J	50V 22P	1	
C3061-74	ECJ1ZF1C104Z	16V 0.1U	14	
C3110	EEEEJA101SP	6.3V 100U	1	
C4207-10	ECJ1ZF1C104Z	16V 0.1U	4	
C4211	F3F1A1060002	10V 10U	1	
C4215	ECJ1ZF1C104Z	16V 0.1U	1	
C4216	F2G0J101A015	6.3V 100U	1	
C4217	ECJ1ZF1C104Z	16V 0.1U	1	
C4219,20	F3F1A1060002	10V 10U	2	
C4222,23	F2G0J331A015	6.3V 330U	2	
C4234-37	ECJ1ZF1C104Z	16V 0.1U	4	
C5101	EEVHB1C100R	16V 10U	1	
C5102,03	ECJ1VF1C104Z	16V 0.1U	2	
C5111	EEVHB0J470R	6.3V 47U	1	
C5115	EEVHB0J470R	6.3V 47U	1	
C5123	ECJ1VF1C104Z	16V 0.1U	1	
C5151	ECJ1VF1C104Z	16V 0.1U	1	
C5152	F3K1A1060001	10V 10U	1	
C5201,02	EEE1CA100SR	16V 10U	2	
C5203-05	ECJ1ZF1C104Z	16V 0.1U	3	
C5221	ECJ1ZF1C104Z	16V 0.1U	1	
C5232-34	ECJ1ZF1C104Z	16V 0.1U	3	
C5235,36	ECJ1VB1C104K	16V 0.1U	2	
C5254	ECJ1VB1H391K	50V 390P	1	
C5256	ECJ1VB1H222K	50V 2200P	1	
C5262	ECJ1VC1H181J	50V 180P	1	
C5264	ECJ1VB1C183K	16V 0.018U	1	
C5271	ECJ1VB1H102K	50V 1000P	1	
C5272	ECJ1VB1A224K	10V 0.22U	1	
C5273	ECJ1VB1H182K	50V 1800P	1	
C5274	ECJ1VB1C104K	16V 0.1U	1	
C5282	ECJ1VB1H103K	50V 0.01U	1	
C5283	ECJ1VC1H561J	50V 560P	1	
C5290	ECJ1VB1H102K	50V 1000P	1	
C5291	ECJ1VB1H272K	50V 2700P	1	
C5292	ECJ1VC1H101J	50V 100P	1	
C5299	ECJ1VC1H331J	50V 330P	1	
C6201	EEEEJA330WR	6.3V 33U	1	
C6202-06	ECJ1ZF1C104Z	16V 0.1U	5	
C6211	ECJ1VC1H101J	50V 100P	1	

Ref. No.	Part No.	Part Name & Description	Pcs	Remarks
C6215	ECJ1VB1C104K	16V 0.1U	1	
C6221-23	ECJ1ZF1C104Z	16V 0.1U	3	
C6251-53	F3F1A1060002	10V 10U	3	
C6254,55	ECJ1ZF1C104Z	16V 0.1U	2	
C6256	ECJ1VB1C104K	16V 0.1U	1	
C6257	EEE0JA101SP	6.3V 100U	1	
C6301,02	ECJ1ZF1C104Z	16V 0.1U	2	
C6503	ECJ1VC1H120J	50V 12P	1	
C6505	ECJ1VC1H150J	50V 15P	1	
C6561	EEE0GA470SR	4V 47U	1	
C6563	EEE0GA470SR	4V 47U	1	
C6564	ECJ1ZF1C104Z	16V 0.1U	1	
C6566	ECJ1ZF1C104Z	16V 0.1U	1	
C6568	ECJ1ZF1C104Z	16V 0.1U	1	
CN1	K1MN14A00049	CONNECTOR(14P)	1	
CN2	K1MN17B00037	CONNECTOR(17P)	1	
CN3	RJS1A6714-Q	CONNECTOR(14P)	1	K1MN14B00054
CN301	K1MN26B00045	CONNECTOR(26P)	1	
CN501	K1MN15B00057	CONNECTOR(15P)	1	
D1	GP1S94	PHOTO COUPLER	1	
D2	B0BA4R600003	DIODE	1	
D3	B0JCPC000004	DIODE	1	
D4	MA2J11100L	DIODE	1	
D6	MA2J11100L	DIODE	1	
D7	MA2J72800L	DIODE	1	
D8	MA2J11100L	DIODE	1	
D10	MA2J11100L	DIODE	1	
D11	MAZ80910ML	DIODE	1	
D12,13	MA2J11100L	DIODE	2	
D14	MAZ80820ML	DIODE	1	
D17,18	MA2J11100L	DIODE	2	
D301	MA2J11100L	DIODE	1	
D302-04	B0AAMM000009	DIODE	3	
D305-07	MA2J11100L	DIODE	3	
D401-06	MA2J11100L	DIODE	6	
D601,02	B3ADA0000083	LED	2	
D603-07	LNJ301MPUJAD	LED	5	
D608	B3AHA0000012	LED	1	
D801-06	MA2J11100L	DIODE	6	
D2001	MA2J72800L	DIODE	1	
D5151	MA2J72800L	DIODE	1	
D6215	MA2J72800L	DIODE	1	
E1	RSC0540-1	GROUND PLATE	1	
FL4201	F1H0J1050018	CHIP FILTER	1	
FL6251	F1H0J1050018	CHIP FILTER	1	
FL6253,54	F1H0J1050018	CHIP FILTER	2	
FL6255	F1J1E1040022	CHIP FILTER	1	
FP2501	K1MN04B00036	CONNECTOR(4P)	1	
FP3202	K1MN17B00041	CONNECTOR(17P)	1	

Ref. No.	Part No.	Part Name & Description	Pcs	Remarks
FP3203	K1MN15B00037	CONNECTOR(15P)	1	
FP4202	K1MN26B00037	CONNECTOR(26P)	1	
FP5101	K1MN30B00098	CONNECTOR(30P)	1	
FP5102	K1MN50B00010	CONNECTOR(50P)	1	
FP5201	K1MN50B00010	CONNECTOR(50P)	1	
IC1	C0GAM0000005	IC	1	
IC2	C0DBAJG00002	IC	1	
IC3	C0CAADG00019	IC	1	
IC4	C0CAADE00007	IC	1	
IC401	C2BBFD000402	IC	1	
IC501	C9ZB00000431	IC	1	
IC601	C0ZBZ0000040	IC	1	
IC801	C0JBAS000138	IC	1	
IC802-04	C0ABBB000125	IC	3	
IC805	C0ABBB000210	IC	1	
IC891	C0JBAR000292	IC	1	
IC2001	MN103S26EGA	IC	1	
IC2101	C0JBAS000116	IC	1	
IC2501	C0GBG0000033	IC	1	
IC3001	MN6775511	IC	1	
IC3061,62	C3ABPG000102	IC	2	
IC4211	C0FBBK000036	IC	1	
IC5201	AN22030A-VT	IC	1	
IC6201	MN102H60GFD	IC	1	
IC6211	C0EBE0000070	IC	1	
IC6221	C3EBGC000033	IC	1	
IC6222,23	C0JBAA000001	IC	2	
IC6251	C0DBEZG00011	IC	1	
IC6252	C0DBFFG00004	IC	1	
IC6253	C0DBCGE00002	IC	1	
IC6301	RFKfMA66M320	IC	1	
IC6561	C1DB00000582	IC	1	
JK1	K1FA220B0006	SYSTEM CONNECTOR(20P)	1	
JK501	K1U208B00003	JK,VIDEO OUT	1	
K2004	ERJ3GEY0R00Z	1/16W 0	1	
K3002,03	ERJ3GEY0R00Z	1/16W 0	2	
K3007	ERJ3GEY0R00Z	1/16W 0	1	
K3009	ERJ3GEY0R00Z	1/16W 0	1	
K3011	ERJ3GEY0R00Z	1/16W 0	1	
K3101	ERJ3GEY0R00Z	1/16W 0	1	
K3106	ERJ3GEY0R00Z	1/16W 0	1	
K4202-05	ERJ3GEY0R00Z	1/16W 0	4	
K4207	ERJ3GEYJ470V	1/16W 47	1	
K6201	ERJ3GEY0R00Z	1/16W 0	1	
K6301	ERJ3GEY0R00Z	1/16W 0	1	
K6303	ERJ3GEY0R00Z	1/16W 0	1	
L1	G0A200D00002	COIL	1	
L2	G0ZZ00001930	COIL	1	
L4	G0A200D00002	COIL	1	

Ref. No.	Part No.	Part Name & Description	Pcs	Remarks
L501,02	G0BYYYY00016	COIL	2	
L503	ELJFCR68KF	COIL	1	
L2001,02	G1C100K00020	COIL	2	
L2021	G1C100K00020	COIL	1	
L3001	G1C100K00020	COIL	1	
L3091	G1C100K00020	COIL	1	
L4211	G1C220KA0038	COIL	1	
L5101	ELJEA100KF	COIL	1	
L5201,02	G1C100K00020	COIL	2	
L6561,62	G1C220KA0038	COIL	2	
LB3001,02	J0JHC0000045	COIL	2	
LB3201-03	ERJ3GEYJ101	1/16W 100	3	D0GB101JA002
LB3205,06	J0JBC0000015	COIL	2	
LB4200	J0JBC0000015	COIL	1	
LB4201	J0JCC0000119	COIL	1	
LB4207-12	J0JCC0000119	COIL	6	
LB4214,15	ERJ3GEY0R00Z	1/16W 0	2	
LB5101	J0JHC0000045	COIL	1	
LB5105,06	J0JBC0000015	COIL	2	
LB5202,03	J0JHC0000045	COIL	2	
LB5205-10	J0JBC0000015	COIL	6	
LB5213	J0JBC0000015	COIL	1	
LB5217-19	J0JBC0000015	COIL	3	
LB5221-24	J0JCC0000119	COIL	4	
LB5225	J0JBC0000015	COIL	1	
LB5226	J0JCC0000119	COIL	1	
LB5227	J0JBC0000015	COIL	1	
LB5228-31	J0JCC0000119	COIL	4	
LB5232	J0JBC0000015	COIL	1	
LB5233	J0JCC0000119	COIL	1	
LB5235-38	J0JCC0000119	COIL	4	
LB5239,40	J0JBC0000015	COIL	2	
LB6201	J0JBC0000015	COIL	1	
LB6202	J0JCC0000119	COIL	1	
LB6221	J0JBC0000015	COIL	1	
LB6561	J0JBC0000015	COIL	1	
LB6562,63	J0JCC0000119	COIL	2	
LB6564	ERJ3GEYJ470V	1/16W 47	1	
LB6565	J0JCC0000077	COIL	1	
LB6566	J0JCC0000119	COIL	1	
LB6567	J0JBC0000015	COIL	1	
PCB1	REP3384G-N	DVD MODULE P.C.B.	1	[RTL]
PCB2	REP3513B-M	MAIN P.C.B.	1	[RTL](GN)
PCB2	REP3513C-M	MAIN P.C.B.	1	[RTL](EE)
PCB3	REP2578A-N	LOADING MOTOR P.C.B.	1	[RTL]
PCB4	REP3406A-1N	TERMINAL P.C.B.	1	[RTL]
PCB5	REP3383A	FG P.C.B.	1	[RTL]
PS6201	K1MN10A00030	CONNECTOR(10P)	1	
Q1	B1GACFGG0004	TRANSISTOR	1	
Q3	B1GBCFJJ0007	TRANSISTOR	1	

Ref. No.	Part No.	Part Name & Description	Pcs	Remarks
Q6	FMW1T98	TRANSISTOR	1	
Q7	2SB14170JA	TRANSISTOR	1	
Q8	FMW1T98	TRANSISTOR	1	
Q9	2SB14170JA	TRANSISTOR	1	
Q11	FMW1T98	TRANSISTOR	1	
Q12	2SB14170JA	TRANSISTOR	1	
Q13	2SB1218A	TRANSISTOR	1	
Q14	FMW1T98	TRANSISTOR	1	
Q15	2SB0766A0L	TRANSISTOR	1	
Q16	2SD08740WL	TRANSISTOR	1	
Q303	B1GBCFJJ0007	TRANSISTOR	1	
Q304	2SB0621AHA	TRANSISTOR	1	
Q305	UNR521N00L	TRANSISTOR	1	
Q307,08	B1GBCFJJ0007	TRANSISTOR	2	
Q401	UNR521400L	TRANSISTOR	1	
Q402-04	2SD1819A0L	TRANSISTOR	3	
Q501	B1GBCFJJ0007	TRANSISTOR	1	
Q801-06	2SD132800L	TRANSISTOR	6	
Q807	UNR511100L	TRANSISTOR	1	
Q891	B1GBCFJJ0007	TRANSISTOR	1	
Q2001	2SD1819A0L	TRANSISTOR	1	
Q5111	B1BDBF000004	TRANSISTOR	1	
Q5115	B1BDBF000004	TRANSISTOR	1	
Q5271	UN5211	TRANSISTOR	1	UNR5211
Q6215	UNR521200L	TRANSISTOR	1	
QR5221	UNR212100L	TRANSISTOR	1	
QR5241	UNR511M00L	TRANSISTOR	1	
R1	ERDS2FJ102	1/4W 1K	1	
R2	ERJ3GEYJ822V	1/16W 8.2K	1	D0GB822JA002
R3	ERJ3GEYJ222V	1/16W 2.2K	1	
R4	ERJ3GEYJ103V	1/16W 10K	1	D0GB103JA002
R16	ERJ3GEYJ471V	1/16W 470	1	
R17	ERJ3GEYJ223V	1/16W 22K	1	D0GB223JA002
R20	ERJ3GEYJ151V	1/16W 150	1	
R21,22	ERJ3GEYJ222V	1/16W 2.2K	2	
R27	ERJ6GEYJ122V	1/10W 1.2K	1	
R28	ERJ3GEYJ473V	1/16W 47K	1	D0GB473JA002
R29	ERJ3GEYJ223V	1/16W 22K	1	D0GB223JA002
R30	ERJ3GEYJ101	1/16W 100	1	D0GB101JA002
R31	ERJ6GEYJ681V	1/10W 680	1	
R32	ERJ3GEYJ473V	1/16W 47K	1	D0GB473JA002
R33	ERJ3GEYJ472V	1/16W 4.7K	1	
R34	ERJ3GEYJ471V	1/16W 470	1	
R35	ERJ6GEYJ122V	1/10W 1.2K	1	
R36	ERJ3GEYJ223V	1/16W 22K	1	D0GB223JA002
R37	ERJ3GEYJ101	1/16W 100	1	D0GB101JA002
R38	ERD2FCG100	1/4W 10	1	
R39	ERJ3GEYJ102V	1/16W 1K	1	
R40	ERJ3GEY0R00V	1/16W 0	1	
R41,42	ERJ3GEYJ101	1/16W 100	2	D0GB101JA002
R43	ERQ16NKWR33E	1/6W 0.33	1	
R44	ERJ3GEYJ122	1/16W 1.2K	1	

Ref. No.	Part No.	Part Name & Description	Pcs	Remarks
R305,06	ERJ3GEYJ103V	1/16W 10K	2	D0GB103JA002
R307	ERJ3GEYJ102V	1/16W 1K	1	
R308	ERJ3GEYJ221V	1/16W 220	1	
R312	ERJ3GEYJ103V	1/16W 10K	1	D0GB103JA002
R314	ERJ3GEYJ103V	1/16W 10K	1	D0GB103JA002
R401	ERJ3GEYJ681V	1/16W 680	1	D0GB681JA002
R402	ERJ3GEYJ104	1/16W 100K	1	
R403	ERJ3GEYJ472V	1/16W 4.7K	1	
R404	ERJ3GEYJ103V	1/16W 10K	1	D0GB103JA002
R405	ERJ3GEYJ471V	1/16W 470	1	
R406	ERJ3GEYJ472V	1/16W 4.7K	1	
R407	ERJ3GEYJ473V	1/16W 47K	1	D0GB473JA002
R408	ERJ3GEYJ472V	1/16W 4.7K	1	
R409	ERJ3GEYJ103V	1/16W 10K	1	D0GB103JA002
R410,11	ERJ3GEYJ472V	1/16W 4.7K	2	
R412	ERJ3GEYJ223V	1/16W 22K	1	D0GB223JA002
R413	ERJ3GEYJ473V	1/16W 47K	1	D0GB473JA002
R414	ERJ3GEYJ221V	1/16W 220	1	
R415	ERJ3GEYJ472V	1/16W 4.7K	1	
R416	ERJ3GEYJ103V	1/16W 10K	1	D0GB103JA002
R417	ERJ3GEYJ102V	1/16W 1K	1	
R418	ERJ3GEYJ473V	1/16W 47K	1	D0GB473JA002
R419	ERJ3GEYJ102V	1/16W 1K	1	
R420	ERJ3GEYJ472V	1/16W 4.7K	1	
R421	ERJ3GEYJ473V	1/16W 47K	1	D0GB473JA002
R422-24	ERJ3GEYJ472V	1/16W 4.7K	3	
R425,26	ERJ3GEYJ103V	1/16W 10K	2	D0GB103JA002
R427	ERJ3GEYD153V	1/16W 15K	1	D0HB153ZA002 (EE)
R427	ERJ3GEYJ682V	1/16W 6.8K	1	D0GB682JA002 (GN)
R428	ERJ3GEYJ103V	1/16W 10K	1	D0GB103JA002
R429-32	ERJ3GEYJ101	1/16W 100	4	D0GB101JA002
R433-35	ERJ3GEYJ221V	1/16W 220	3	
R436	ERJ3GEYJ472V	1/16W 4.7K	1	
R438,39	ERJ3GEYJ821V	1/16W 820	2	
R440-42	ERJ3GEYJ102V	1/16W 1K	3	
R443	ERJ3GEYJ223V	1/16W 22K	1	D0GB223JA002
R444	ERJ3GEYJ104	1/16W 100K	1	
R445	ERJ3GEYJ223V	1/16W 22K	1	D0GB223JA002
R446	ERJ3GEYJ472V	1/16W 4.7K	1	
R447,48	ERJ3GEYJ221V	1/16W 220	2	
R450,51	ERJ3GEYJ103V	1/16W 10K	2	D0GB103JA002
R452	ERJ3GEYJ821V	1/16W 820	1	
R454,55	ERJ3GEYJ472V	1/16W 4.7K	2	
R456	ERJ3GEYJ222V	1/16W 2.2K	1	
R501,02	ERJ3GEYJ1R0V	1/16W 1	2	
R503	ERJ3EKF75R0	1/16W 75	1	
R504,05	ERJ3GEYJ1R0V	1/16W 1	2	
R506,07	ERJ3EKF75R0	1/16W 75	2	
R508-10	ERJ3GEYJ104	1/16W 100K	3	
R512	ERJ3GEYJ822V	1/16W 8.2K	1	D0GB822JA002
R513	ERJ3GEYJ222V	1/16W 2.2K	1	
R601-04	ERJ3GEYJ101	1/16W 100	4	D0GB101JA002
R605,06	ERJ3GEYJ271V	1/16W 270	2	
R607-11	ERJ3GEYJ221V	1/16W 220	5	

Ref. No.	Part No.	Part Name & Description	Pcs	Remarks
R612	ERJ3GEYJ181V	1/16W 180	1	
R613	ERJ3GEYJ223V	1/16W 22K	1	D0GB223JA002
R614	ERJ3GEYJ123V	1/16W 12K	1	
R615	ERJ3GEYJ682V	1/16W 6.8K	1	D0GB682JA002
R616	ERJ3GEYJ472V	1/16W 4.7K	1	
R617	ERJ3GEYJ332V	1/16W 3.3K	1	D0GB332JA002
R618	ERJ3GEYJ222V	1/16W 2.2K	1	
R619	ERJ3GEYJ182V	1/16W 1.8K	1	
R620	ERJ3GEYJ152V	1/16W 1.5K	1	
R621	ERJ3GEYJ122	1/16W 1.2K	1	
R622	ERJ3GEYJ102V	1/16W 1K	1	
R623	ERJ3GEYJ123V	1/16W 12K	1	
R624	ERJ3GEYJ682V	1/16W 6.8K	1	D0GB682JA002
R625	ERJ3GEYJ472V	1/16W 4.7K	1	
R626	ERJ3GEYJ332V	1/16W 3.3K	1	D0GB332JA002
R627	ERJ3GEYJ222V	1/16W 2.2K	1	
R628	ERJ3GEYJ182V	1/16W 1.8K	1	
R629	ERJ3GEYJ152V	1/16W 1.5K	1	
R630	ERJ3GEYJ122	1/16W 1.2K	1	
R631	ERJ3GEYJ102V	1/16W 1K	1	
R801	ERJ3GEYJ102V	1/16W 1K	1	
R802	ERJ3GEYJ182V	1/16W 1.8K	1	
R803,04	ERJ3GEYJ104	1/16W 100K	2	
R805,06	ERJ3GEYJ103V	1/16W 10K	2	D0GB103JA002
R807,08	ERJ3GEYJ223V	1/16W 22K	2	D0GB223JA002
R809	ERJ3GEYD153V	1/16W 15K	1	D0HB153ZA002
R810	ERJ3GEYJ223V	1/16W 22K	1	D0GB223JA002
R811,12	ERJ3GEYJ103V	1/16W 10K	2	D0GB103JA002
R813,14	ERJ3GEYJ332V	1/16W 3.3K	2	D0GB332JA002
R815	ERJ3GEYJ102V	1/16W 1K	1	
R816	ERJ3GEYJ471V	1/16W 470	1	
R817,18	ERJ3GEYJ473V	1/16W 47K	2	D0GB473JA002
R819-24	ERJ3GEYJ104	1/16W 100K	6	
R825	ERJ3GEYJ122	1/16W 1.2K	1	
R826	ERJ3GEYJ562V	1/16W 5.6K	1	D0GB562JA002
R827,28	ERJ3GEYJ101	1/16W 100	2	D0GB101JA002
R829,30	ERJ3GEYJ104	1/16W 100K	2	
R831,32	ERJ3GEYD153V	1/16W 15K	2	D0HB153ZA002
R833,34	ERJ3GEYJ223V	1/16W 22K	2	D0GB223JA002
R835,36	ERJ3GEYJ103V	1/16W 10K	2	D0GB103JA002
R837,38	ERJ3GEYD153V	1/16W 15K	2	D0HB153ZA002
R839,40	ERJ3GEYJ332V	1/16W 3.3K	2	D0GB332JA002
R841,42	ERJ3GEYJ102V	1/16W 1K	2	
R843,44	ERJ3GEYJ473V	1/16W 47K	2	D0GB473JA002
R845,46	ERJ3GEYJ104	1/16W 100K	2	
R847,48	ERJ3GEYJ102V	1/16W 1K	2	
R849,50	ERJ3GEYJ104	1/16W 100K	2	
R851,52	ERJ3GEYJ103V	1/16W 10K	2	D0GB103JA002
R853,54	ERJ3GEYJ223V	1/16W 22K	2	D0GB223JA002
R855,56	ERJ3GEYJ103V	1/16W 10K	2	D0GB103JA002
R857,58	ERJ3GEYD153V	1/16W 15K	2	D0HB153ZA002
R859,60	ERJ3GEYJ332V	1/16W 3.3K	2	D0GB332JA002
R861,62	ERJ3GEYJ102V	1/16W 1K	2	
R863,64	ERJ3GEYJ473V	1/16W 47K	2	D0GB473JA002

Ref. No.	Part No.	Part Name & Description	Pcs	Remarks
R865,66	ERJ3GEYJ104	1/16W 100K	2	
R867	ERJ3GEYJ473V	1/16W 47K	1	D0GB473JA002
R891,92	ERJ3GEYJ104	1/16W 100K	2	
R893	ERJ3GEYJ103V	1/16W 10K	1	D0GB103JA002
R899	ERJ3GEY0R00V	1/16W 0	1	
R2021	ERJ3GEYJ473V	1/16W 47K	1	D0GB473JA002
R2022,23	ERJ3GEYJ752V	1/16W 7.5K	2	
R2025,26	ERJ3GEYJ223V	1/16W 22K	2	D0GB223JA002
R2027,28	ERJ3GEYJ563V	1/16W 56K	2	
R2029	ERJ3GEYJ103V	1/16W 10K	1	D0GB103JA002
R2030	ERJ3GEYJ102V	1/16W 1K	1	
R2031	MCR03PZHJ561	1/16W 560	1	
R2032	ERJ3GEYJ103V	1/16W 10K	1	D0GB103JA002
R2033	ERJ3GEYJ472V	1/16W 4.7K	1	
R2034	ERJ3GEYJ473V	1/16W 47K	1	D0GB473JA002
R2035	ERJ3GEYJ272V	1/16W 2.7K	1	
R2036	ERJ3GEY0R00Z	1/16W 0	1	
R2037	ERJ3GEYJ683V	1/16W 68K	1	D0GB683JA002
R2038	ERJ3GEYD153V	1/16W 15K	1	D0HB153ZA002
R2039	ERJ3GEYJ105V	1/16W 1M	1	
R2040,41	ERJ3GEYJ822V	1/16W 8.2K	2	D0GB822JA002
R2042-47	ERJ3GEYD153V	1/16W 15K	6	D0HB153ZA002
R2048	ERJ3GEYJ475V	1/16W 4.7M	1	
R2049	ERJ3GEYJ102V	1/16W 1K	1	
R2051,52	ERJ3GEYJ101	1/16W 100	2	D0GB101JA002
R2053,54	ERJ3GEYJ473V	1/16W 47K	2	D0GB473JA002
R2501	ERJ3GEYJ101	1/16W 100	1	D0GB101JA002
R2502,03	ERJ3GEYD153V	1/16W 15K	2	D0HB153ZA002
R2504,05	ERJ3GEYJ823V	1/16W 82K	2	D0GB823JA002
R2507	ERJ6GEYJ6R8V	1/8W 6.8	1	
R3001	ERJ3GEYJ220V	1/16W 22	1	
R3006	ERJ3RBD153	1/16W 15K	1	
R3007	ERJ3RBD202	1/16W 2K	1	
R3008	ERJ3RBD132V	1/16W 1.3K	1	
R3009,10	ERJ3GEYJ101	1/16W 100	2	D0GB101JA002
R3051,52	ERJ3GEYJ101	1/16W 100	2	D0GB101JA002
R3101	ERJ3RED620V	1/16W 62	1	
R3102	ERJ3RED150V	1/16W 15	1	
R3106	ERJ3RED620V	1/16W 62	1	
R3107	ERJ3RED180	1/16W 18	1	
R5101-03	ERJ3GEYJ560V	1/16W 56	3	
R5105	ERJ12Y0R00U	1/12W 0	1	
R5107-09	ERJ3GEY0R00V	1/16W 0	3	
R5111	ERJ3GEYJ2R2V	1/16W 2.2	1	D0GB2R2JA002
R5112	ERJ12YJ270H	1/2W 27	1	
R5113	ERJ3GEYJ473V	1/16W 47K	1	D0GB473JA002
R5114	ERJ3GEYJ223V	1/16W 22K	1	D0GB223JA002
R5115	ERJ3GEYJ2R2V	1/16W 2.2	1	D0GB2R2JA002
R5116	ERJ12YJ270H	1/2W 27	1	
R5117	ERJ3GEYJ473V	1/16W 47K	1	D0GB473JA002
R5120	ERJ3GEY0R00V	1/16W 0	1	
R5121-23	ERJ3GEYJ560V	1/16W 56	3	
R5124	ERJ3GEYJ472V	1/16W 4.7K	1	
R5152	ERJ3GEYJ102V	1/16W 1K	1	

Ref. No.	Part No.	Part Name & Description	Pcs	Remarks
R5201	ERJ3GEY0R00Z	1/16W 0	1	
R5203	ERJ3GEY0R00Z	1/16W 0	1	
R5204	ERJ3GEYJ102V	1/16W 1K	1	
R5221	ERJ3GEY0R00Z	1/16W 0	1	
R5231,32	ERJ3GEYJ822V	1/16W 8.2K	2	D0GB822JA002
R5241	ERJ3GEYJ221V	1/16W 220	1	
R5242	ERJ3GEYJ823V	1/16W 82K	1	D0GB823JA002
R5257	ERJ3GEY0R00Z	1/16W 0	1	
R5262	ERJ3GEY0R00Z	1/16W 0	1	
R5281	ERJ3GEYJ105V	1/16W 1M	1	
R5294	ERJ3GEYJ123V	1/16W 12K	1	
R5295	D0GB243JA002	1/16W 24K	1	
R5320	ERJ3GEY0R00Z	1/16W 0	1	
R6201	ERJ3GEYJ473V	1/16W 47K	1	D0GB473JA002
R6202	ERJ3GEYJ103V	1/16W 10K	1	D0GB103JA002
R6206	ERJ3GEYJ103V	1/16W 10K	1	D0GB103JA002
R6207,08	ERJ3GEYJ472V	1/16W 4.7K	2	
R6210	ERJ3GEYJ101	1/16W 100	1	D0GB101JA002
R6211	ERJ3GEYJ472V	1/16W 4.7K	1	
R6215	ERJ3GEYJ103V	1/16W 10K	1	D0GB103JA002
R6216	ERJ3GEYJ102V	1/16W 1K	1	
R6251,52	ERJ3RBD101	1/16W 100	2	ERJ3RBD101V
R6253	ERJ3RBD102V	1/16W 1K	1	
R6503	ERJ3RBD331	1/16W 330	1	
R6504,05	ERJ3GEY0R00Z	1/16W 0	2	
R6563	ERJ3GEYJ103V	1/16W 10K	1	D0GB103JA002
R6565	ERJ3GEYJ470V	1/16W 47	1	
R6566	ERJ3GEYJ100	1/16W 10	1	
RA2021	EXBV4V102JV	1/32W 1K	1	
RA2022	EXBV4V472JV	1/32W 4.7K	1	
RA2501	EXBV8V473JV	1/16W 47K	1	
RA3001	EXBV4V102JV	1/32W 1K	1	
RA3002-12	EXBV8V820J	1/16W 82	11	
RA3013	EXBV4V220JV	1/32W 22	1	
RA3051	EXBV4V101JV	1/32W 100	1	
RA3053	EXBV4V101JV	1/32W 100	1	
RA5101	EXBV4V560J	1/32W 56	1	
RA5102	EXBV8V560JV	1/16W 56	1	
RA5103	EXBV4V560J	1/32W 56	1	
RA5201	EXBV8V101JV	1/16W 100	1	
RA6201,02	EXBV4V103JV	1/32W 10K	2	
RA6203	EXBV4V472JV	1/32W 4.7K	1	
RA6204	EXBV4V103JV	1/32W 10K	1	
RA6205	EXBV8V103J	1/16W 10K	1	
RA6206	EXBV4V473JV	1/32W 47K	1	
S1,S2	RSH1A032-U	SW,TRAY POSITION DET.	2	K0F111B00057
S3	RSH1A005	SW,OPEN/CLOSE DET.	1	
S4	RSH1A91ZA-A	SW,CLAMP	1	K0L1BA000007
S5	K0L1BB000005	SW,BOTTOM	1	
S601-21	EVQ11G05R	SW,OPERATION	21	
S2501	RSH1A048-A	SW,REST DET.	1	

Ref. No.	Part No.	Part Name & Description	Pcs	Remarks
SJ313	ERJ3GEY0R00V	1/16W 0	1	
X401	H2B800400005	OSCILLATOR	1	
X6501	H0J368600005	OSCILLATOR	1	
Z501-03	J0JBC0000015	COIL	3	

19. Cabinet parts Location

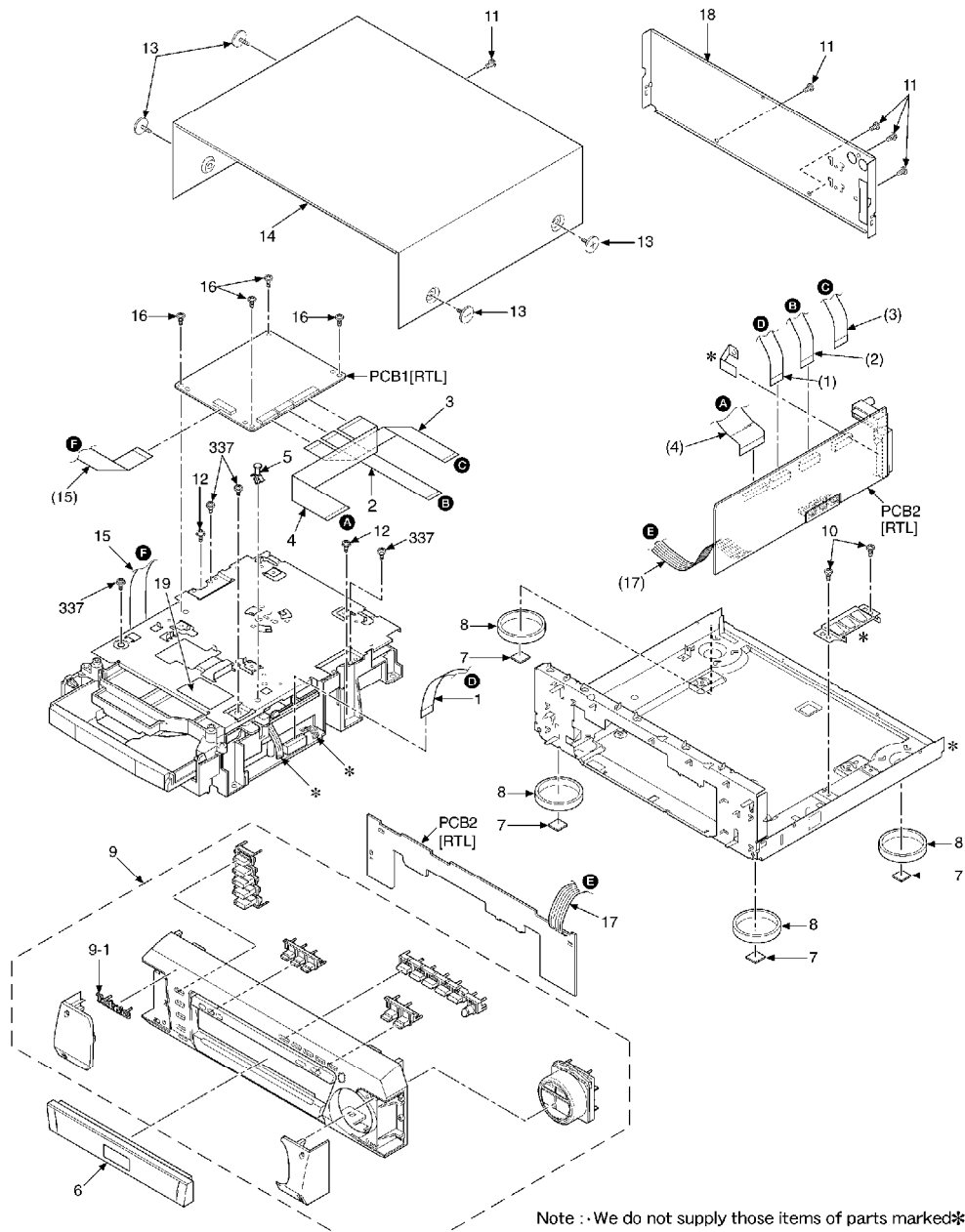

Note : - We do not supply those items of parts marked* .
 - This "PCB2" is a combination PCB.

20. Loading Mechanism Parts Location

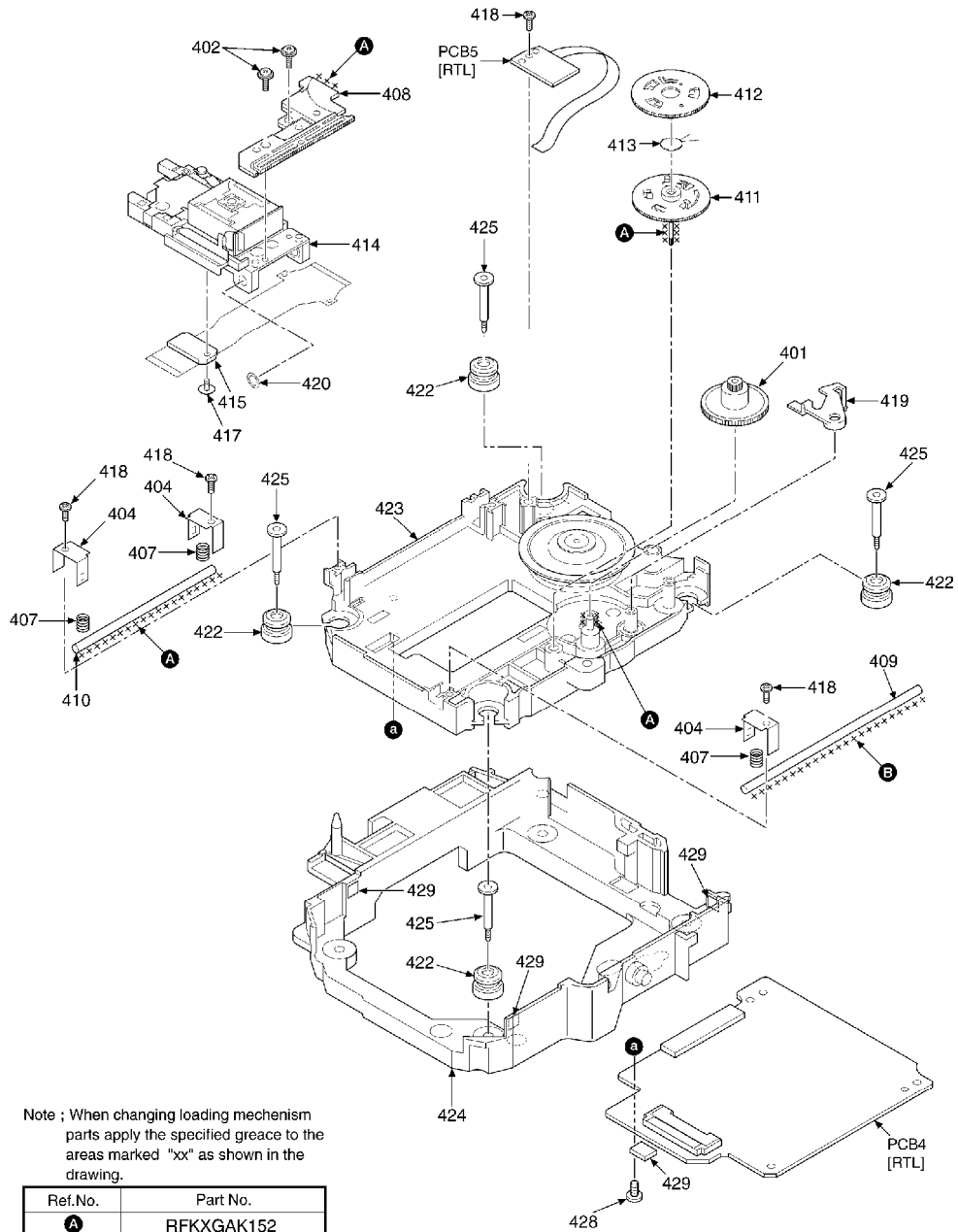

Note :- We do not supply those items of parts marked* .

21. Traverse Mechanism Parts Location

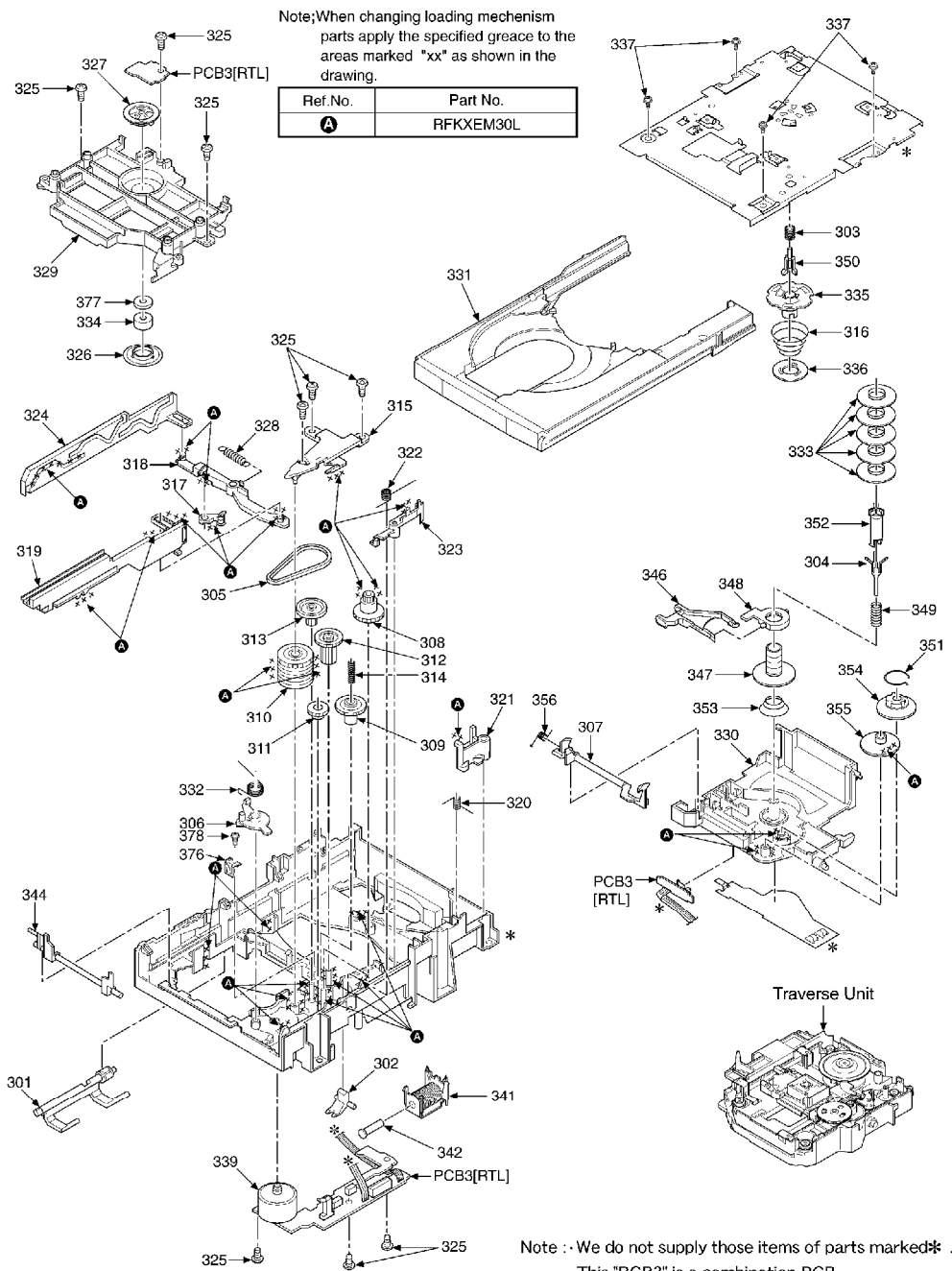

22. Schematic Diagram for printing with A4 size K0305 YH/HM

B DVD MODULE(AVDEC) CIRCUIT

→ : POSITIVE VOLTAGE LINE ⇨ : AUDIO/VIDEO SIGNAL LINE ⇩ : AUDIO SIGNAL LINE ⇨ : VIDEO SIGNAL LINE

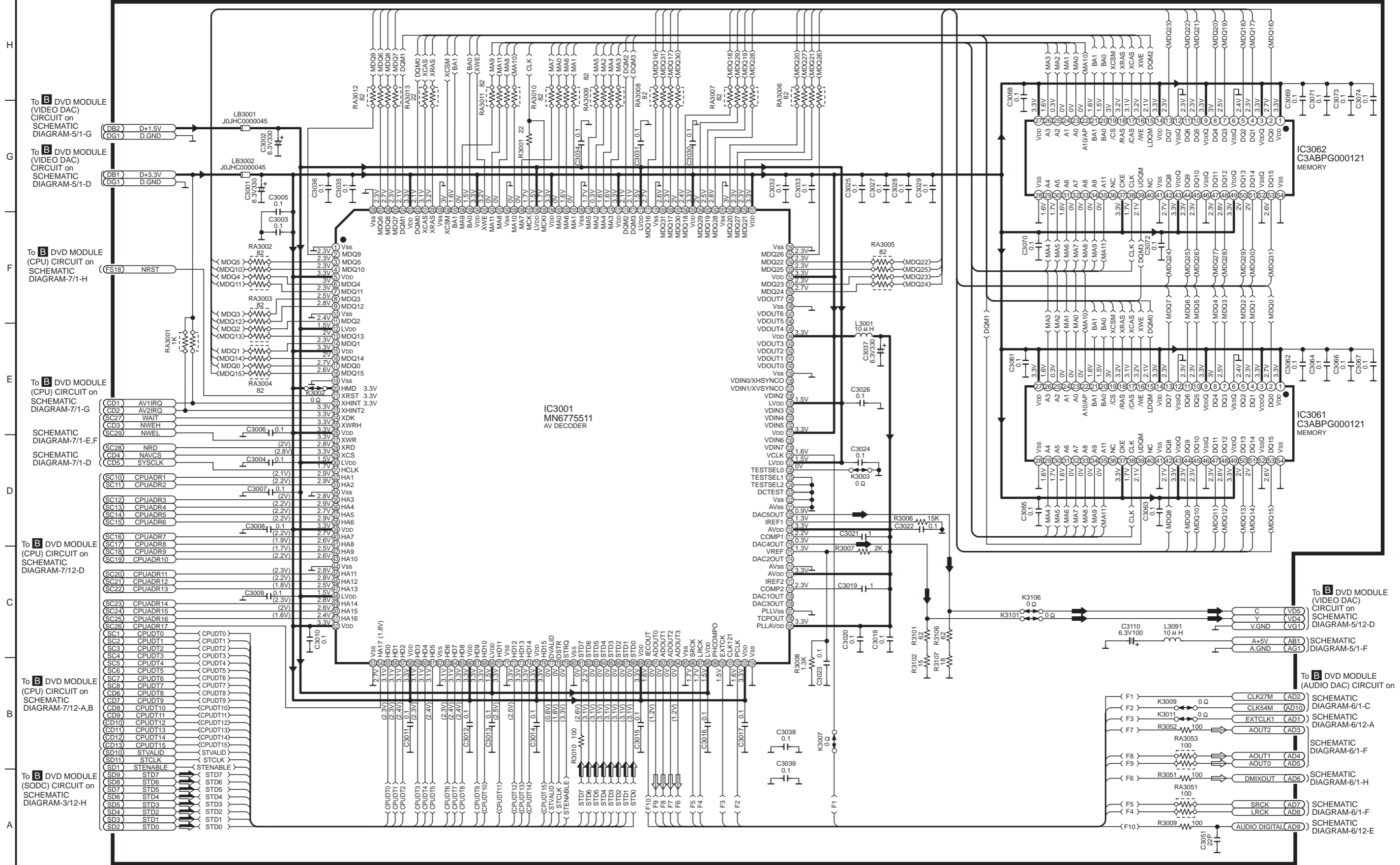

To B DVD MODULE (VIDEO DAC) CIRCUIT on SCHEMATIC DIAGRAM-5/1-G

To B DVD MODULE (VIDEO DAC) CIRCUIT on SCHEMATIC DIAGRAM-5/1-D

To B DVD MODULE (CPU) CIRCUIT on SCHEMATIC DIAGRAM-7/1-H

To B DVD MODULE (CPU) CIRCUIT on SCHEMATIC DIAGRAM-7/1-G

SCHEMATIC DIAGRAM-7/1-E,F

SCHEMATIC DIAGRAM-7/1-D

To B DVD MODULE (CPU) CIRCUIT on SCHEMATIC DIAGRAM-7/12-D

To B DVD MODULE (CPU) CIRCUIT on SCHEMATIC DIAGRAM-7/12-A,B

To B DVD MODULE (SODC) CIRCUIT on SCHEMATIC DIAGRAM-3/12-H

To B DVD MODULE (VIDEO DAC) CIRCUIT on SCHEMATIC DIAGRAM-5/12-D

To B DVD MODULE (AUDIO DAC) CIRCUIT on SCHEMATIC DIAGRAM-6/1-C

SCHEMATIC DIAGRAM-6/12-A

SCHEMATIC DIAGRAM-6/1-F

SCHEMATIC DIAGRAM-6/1-H

SCHEMATIC DIAGRAM-6/1-F

SCHEMATIC DIAGRAM-6/12-E

SCHEMATIC DIAGRAM-5

B DVD MODULE(VIDEO DAC) CIRCUIT → : POSITIVE VOLTAGE LINE → : VIDEO SIGNAL LINE

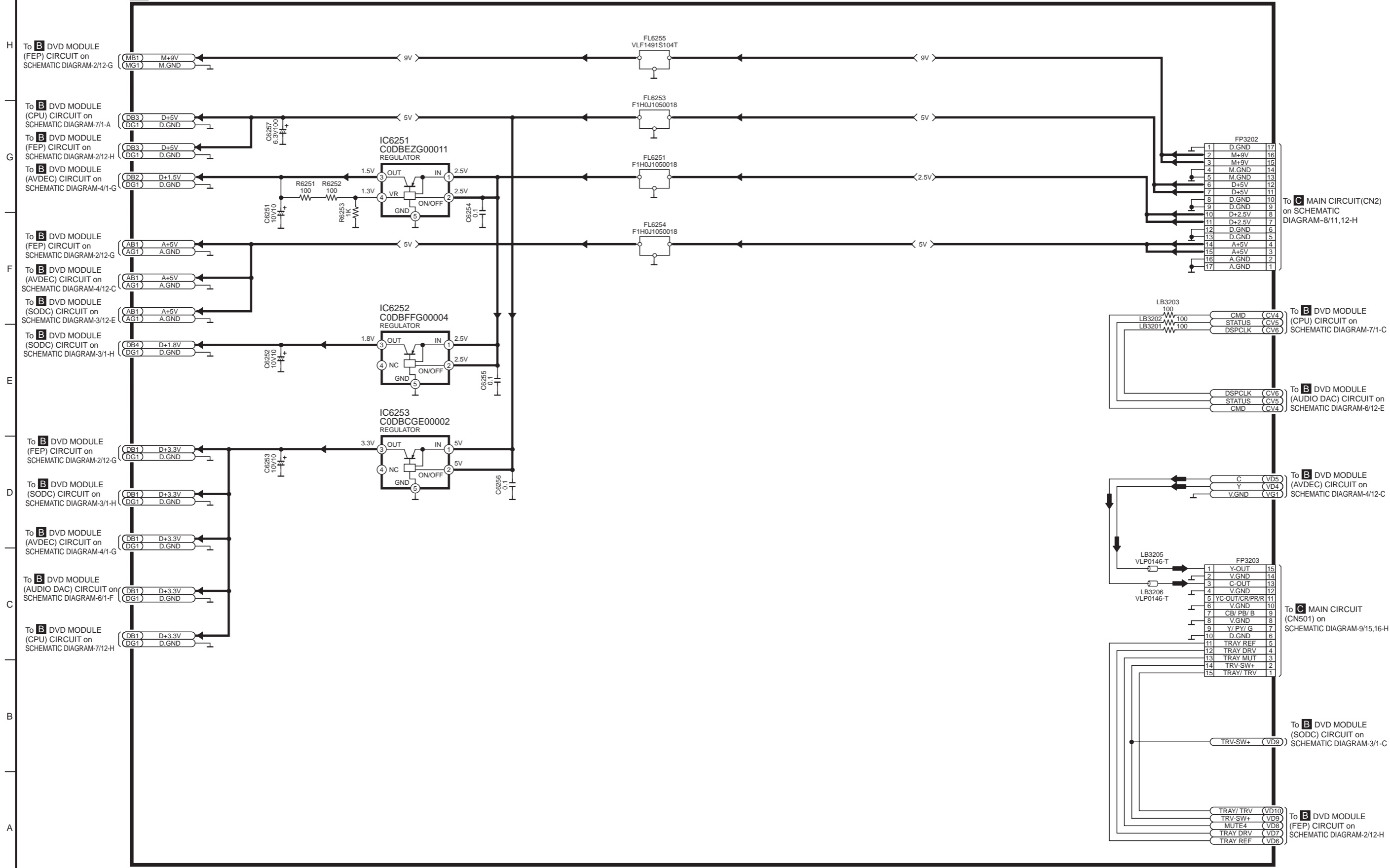

H To **B** DVD MODULE (FEP) CIRCUIT on SCHEMATIC DIAGRAM-2/12-G

G To **B** DVD MODULE (CPU) CIRCUIT on SCHEMATIC DIAGRAM-7/1-A

To **B** DVD MODULE (FEP) CIRCUIT on SCHEMATIC DIAGRAM-2/12-H

To **B** DVD MODULE (AVDEC) CIRCUIT on SCHEMATIC DIAGRAM-4/1-G

F To **B** DVD MODULE (FEP) CIRCUIT on SCHEMATIC DIAGRAM-2/12-G

To **B** DVD MODULE (AVDEC) CIRCUIT on SCHEMATIC DIAGRAM-4/12-C

To **B** DVD MODULE (SODC) CIRCUIT on SCHEMATIC DIAGRAM-3/12-E

To **B** DVD MODULE (SODC) CIRCUIT on SCHEMATIC DIAGRAM-3/1-H

E To **B** DVD MODULE (FEP) CIRCUIT on SCHEMATIC DIAGRAM-2/12-G

To **B** DVD MODULE (SODC) CIRCUIT on SCHEMATIC DIAGRAM-3/1-H

D To **B** DVD MODULE (AVDEC) CIRCUIT on SCHEMATIC DIAGRAM-4/1-G

To **B** DVD MODULE (AUDIO DAC) CIRCUIT on SCHEMATIC DIAGRAM-6/1-F

C To **B** DVD MODULE (CPU) CIRCUIT on SCHEMATIC DIAGRAM-7/12-H

B

A

To **C** MAIN CIRCUIT(CN2) on SCHEMATIC DIAGRAM-8/11,12-H

1	D.GND	17
2	M+9V	16
3	M+9V	15
4	M.GND	14
5	M.GND	13
6	D+5V	12
7	D+5V	11
8	D.GND	10
9	D.GND	9
10	D+2.5V	8
11	D+2.5V	7
12	D.GND	6
13	D.GND	5
14	A+5V	4
15	A+5V	3
16	A.GND	2
17	A.GND	1

To **B** DVD MODULE (CPU) CIRCUIT on SCHEMATIC DIAGRAM-7/1-C

CMD	(CV4)
STATUS	(CV5)
DSPCLK	(CV6)

To **B** DVD MODULE (AUDIO DAC) CIRCUIT on SCHEMATIC DIAGRAM-6/12-E

DSPCLK	(CV6)
STATUS	(CV5)
CMD	(CV4)

To **B** DVD MODULE (AVDEC) CIRCUIT on SCHEMATIC DIAGRAM-4/12-C

C	(VD5)
Y	(VD4)
V.GND	(VG1)

To **C** MAIN CIRCUIT (CN501) on SCHEMATIC DIAGRAM-9/15,16-H

1	Y-OUT	15
2	V.GND	14
3	C-OUT	13
4	V.GND	12
5	YC-OUT/CR/PR/R	11
6	V.GND	10
7	CB/ PB/ B	9
8	V.GND	8
9	Y/ PY/ G	7
10	D.GND	6
11	TRAY REF	5
12	TRAY DRV	4
13	TRAY MUT	3
14	TRV-SW+	2
15	TRAY/ TRV	1

To **B** DVD MODULE (SODC) CIRCUIT on SCHEMATIC DIAGRAM-3/1-C

TRV-SW+	(VD9)
---------	-------

To **B** DVD MODULE (FEP) CIRCUIT on SCHEMATIC DIAGRAM-2/12-H

TRAY/ TRV	(VD10)
TRV-SW+	(VD9)
MUTE4	(VD8)
TRAY DRV	(VD7)
TRAY REF	(VD6)

SCHEMATIC DIAGRAM-6

B DVD MODULE(AUDIO DAC) CIRCUIT

→: POSITIVE VOLTAGE LINE ⇨: AUDIO SIGNAL LINE ⇨⇨: SURROUND SP. SIGNAL LINE ⇨⇨⇨: CENTER SP. SIGNAL LINE ⇨⇨⇨⇨: SUB WOOFER SIGNAL LINE

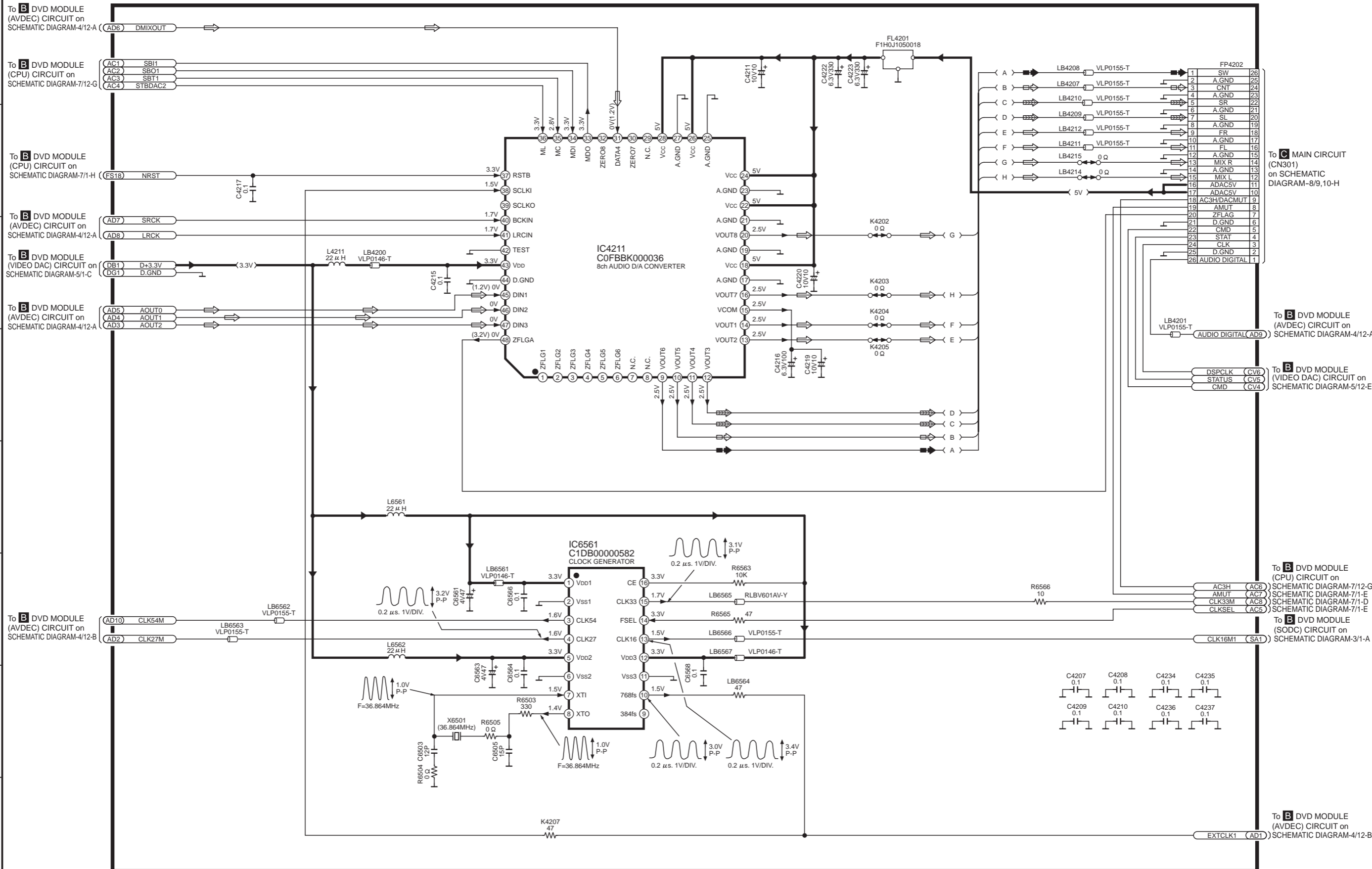

SCHEMATIC DIAGRAM-7

B DVD MODULE(CPU) CIRCUIT

→ : POSITIVE VOLTAGE LINE

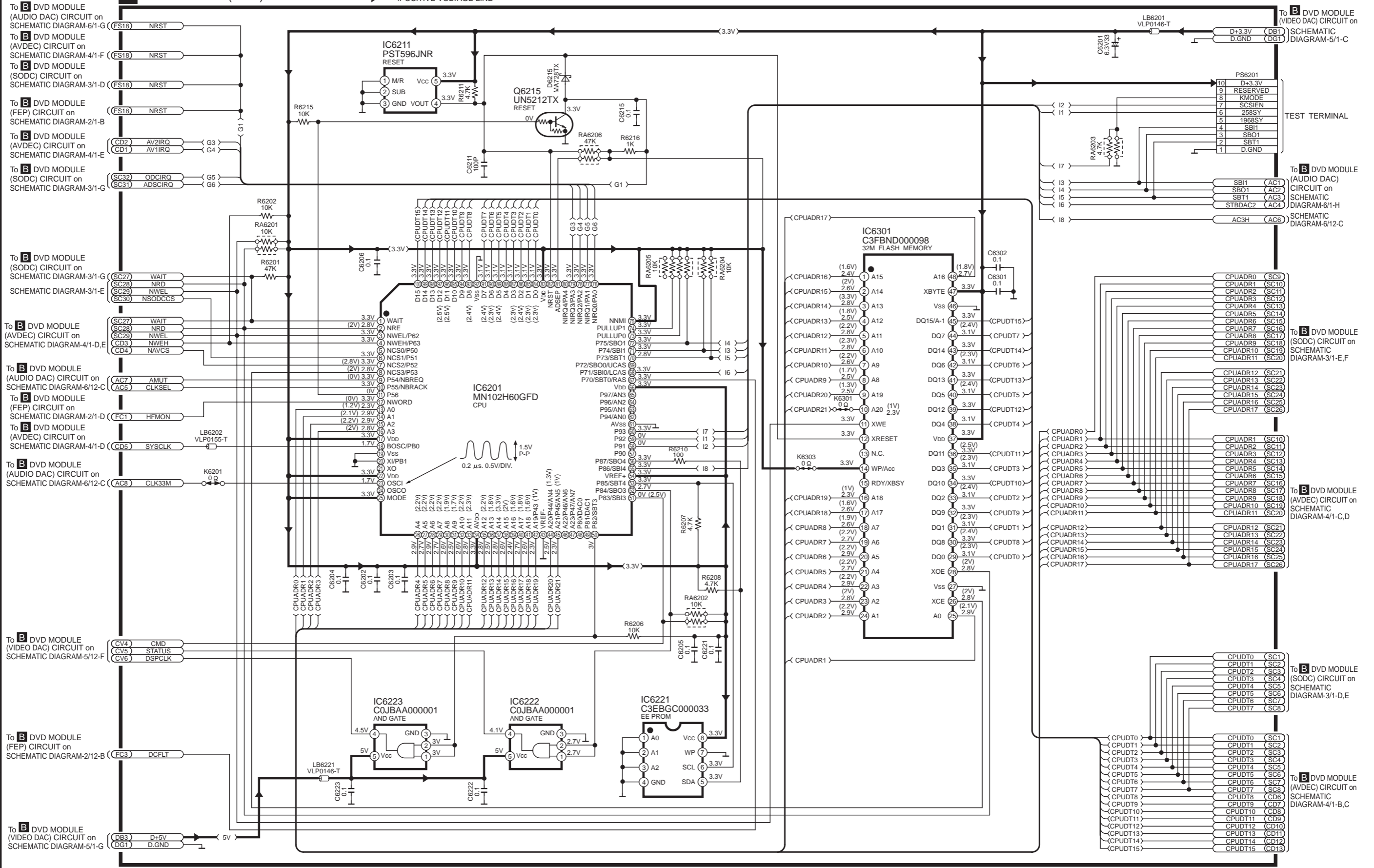

SL-DV290(EE,GN) DVD MODULE(CPU) CIRCUIT DIAGRAM

SCHEMATIC DIAGRAM-8

- : POSITIVE VOLTAGE LINE
- ⇨ : AUDIO SIGNAL LINE
- ⇨⇨ : SURROUND SP. SIGNAL LINE
- ⇨⇨⇨ : CENTER SP. SIGNAL LINE
- ⇨⇨⇨⇨ : SUB WOOFER SIGNAL LINE

E LOADING MOTOR CIRCUIT

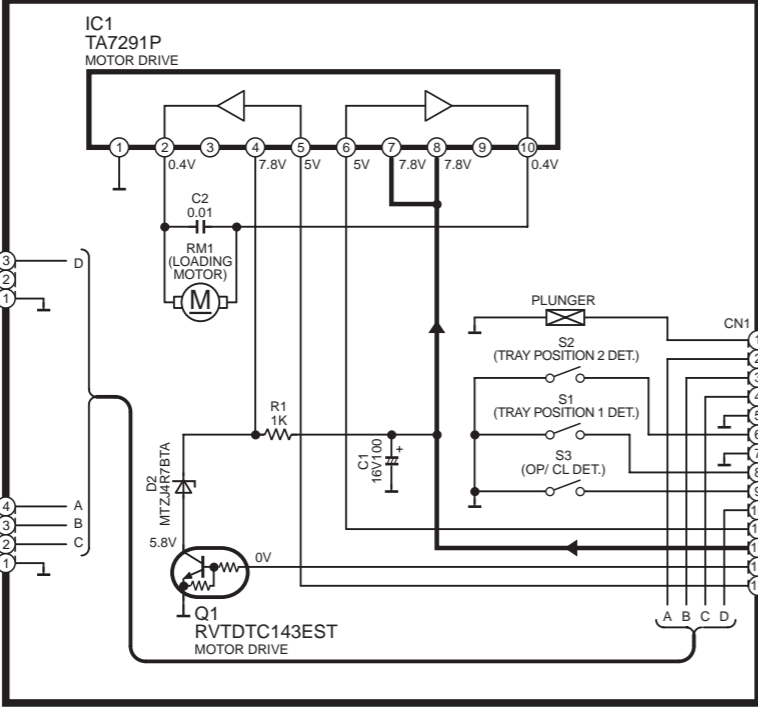

F CLAMP SW CIRCUIT

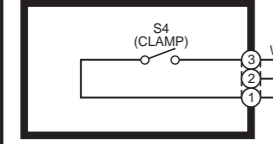

G BOTTOM SW CIRCUIT

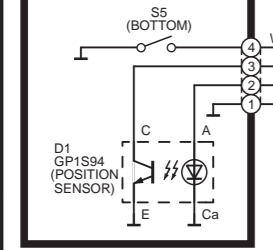

D OPERATION CIRCUIT

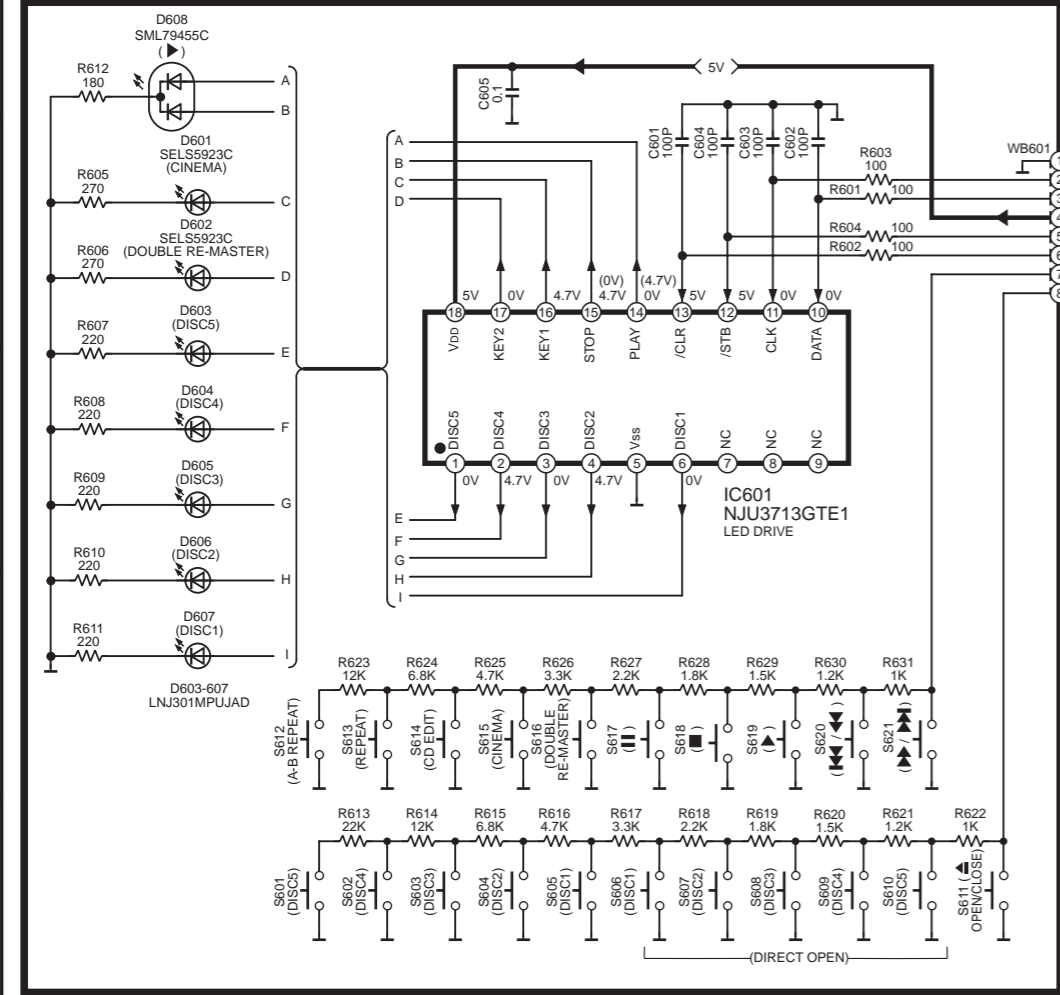

C MAIN CIRCUIT

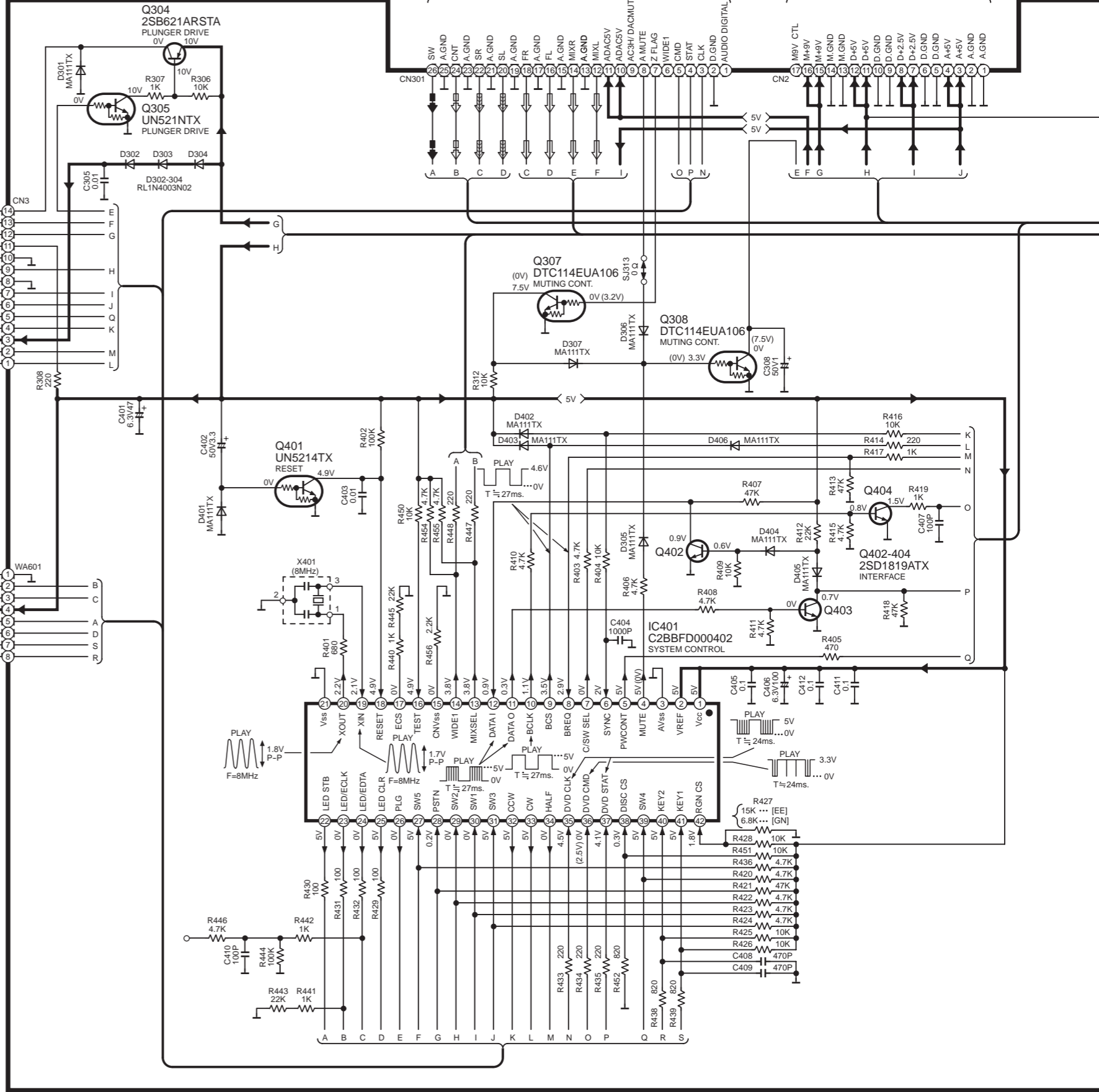

C MAIN CIRCUIT

To **B** MODULE CIRCUIT (FP3203) on SCHEMATIC DIAGRAM-5/12-C

→ : POSITIVE VOLTAGE LINE ⇨ : AUDIO SIGNAL LINE ⇩ : VIDEO SIGNAL LINE ⇨⇨ : SURROUND SP. SIGNAL LINE ⇨⇨⇨ : CENTER SP. SIGNAL LINE ⇨⇨⇨⇨ : SUB WOOFER SIGNAL LINE

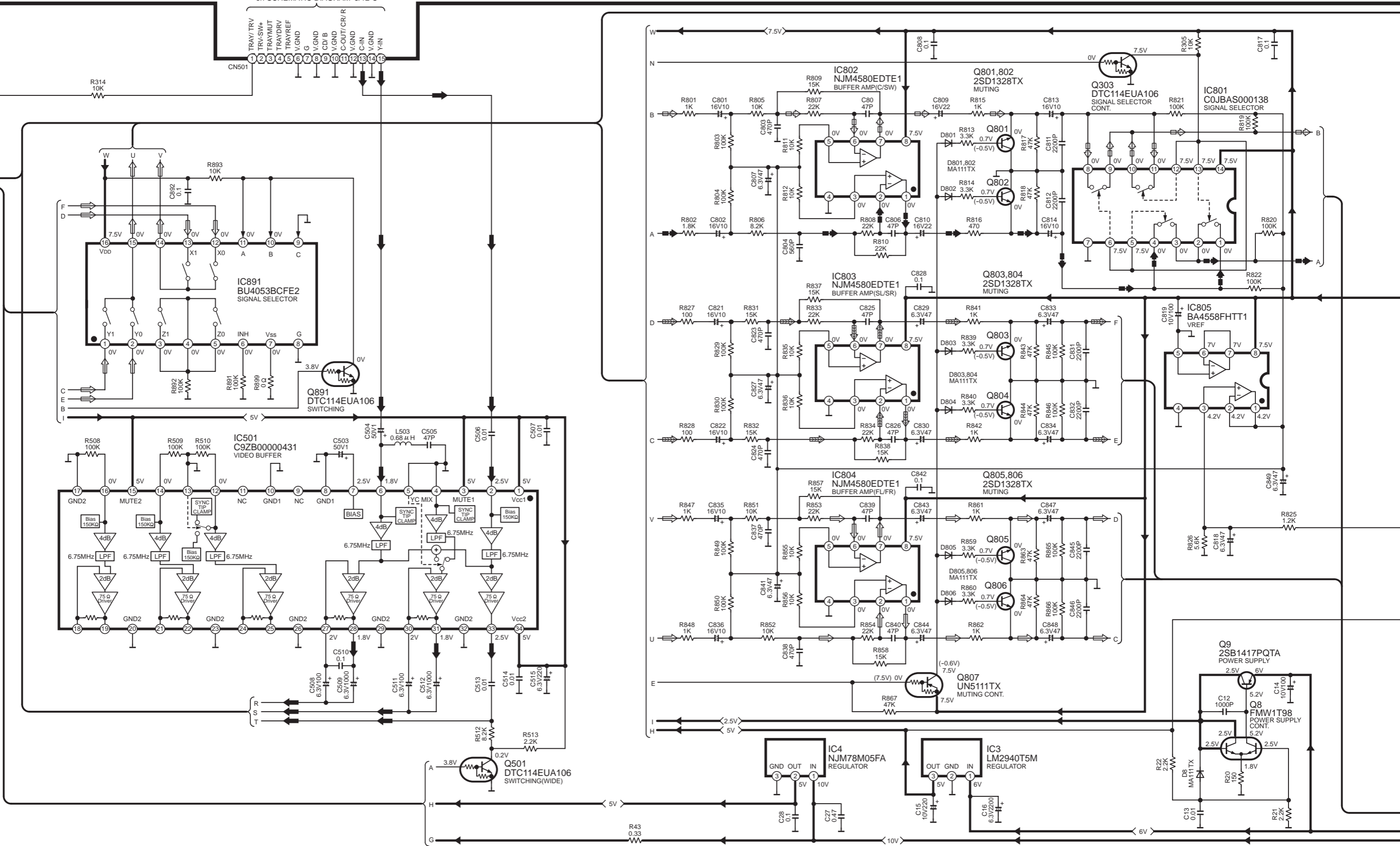

C SCHEMATIC DIAGRAM-10
MAIN CIRCUIT

: POSITIVE VOLTAGE LINE
 : AUDIO SIGNAL LINE
 : CENTER SP. SIGNAL LINE
 : VIDEO SIGNAL LINE
 : SUB WOOFER SIGNAL LINE
 : SURROUND SP. SIGNAL LINE

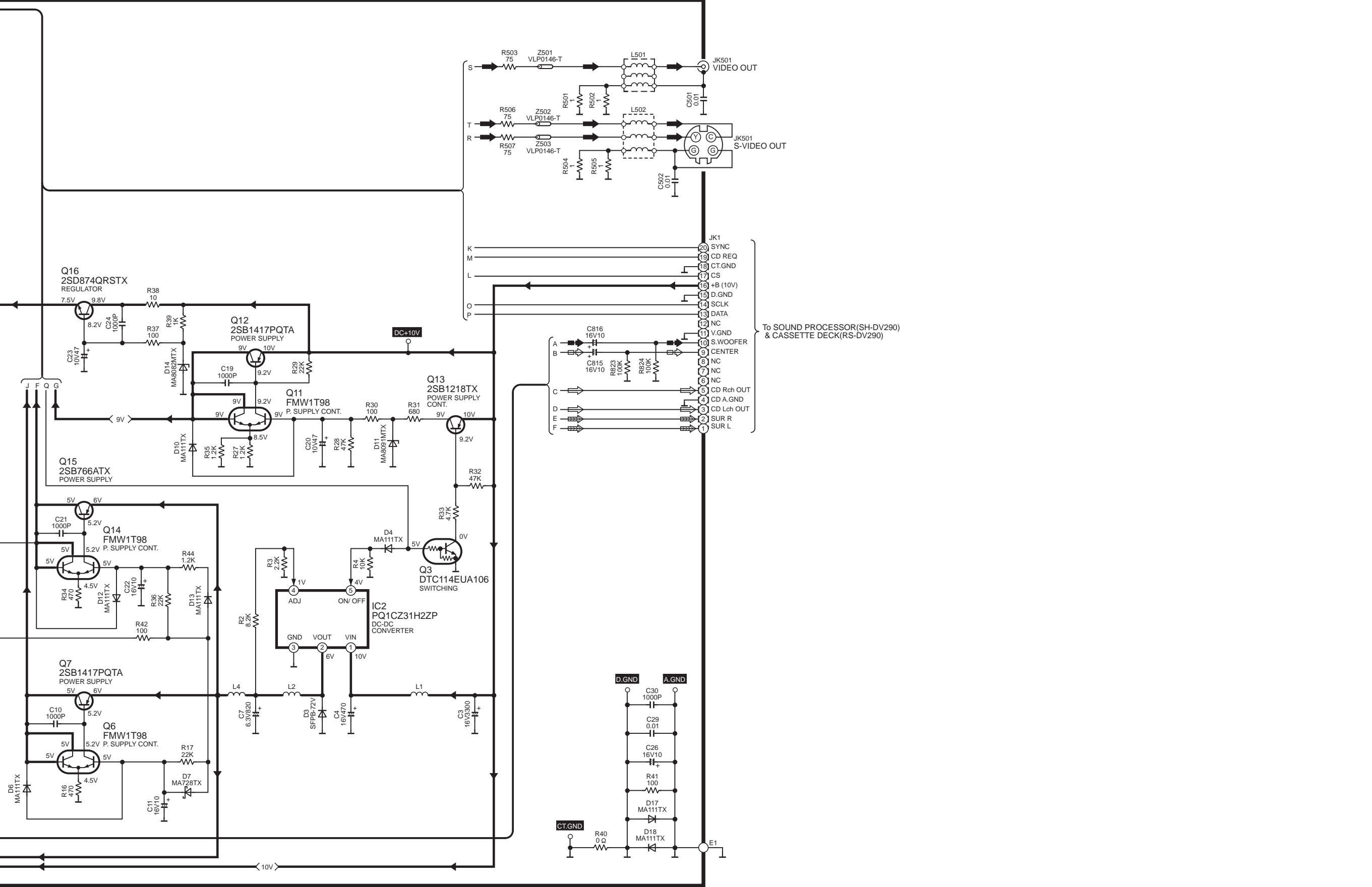

To SOUND PROCESSOR(SH-DV290) & CASSETTE DECK(RS-DV290)

SL-DV290(EE,GN) MAIN CIRCUIT DIAGRAM

SCHEMATIC DIAGRAM-1

NOTE:
The number which noted at the connectors on the schematic diagram as "SCHEMATIC DIAGRAM-1" or "SCHEMATIC DIAGRAM-2" indicates the schematic diagram serial number located on the left corner in the schematic of

A INTERFACE CIRCUIT

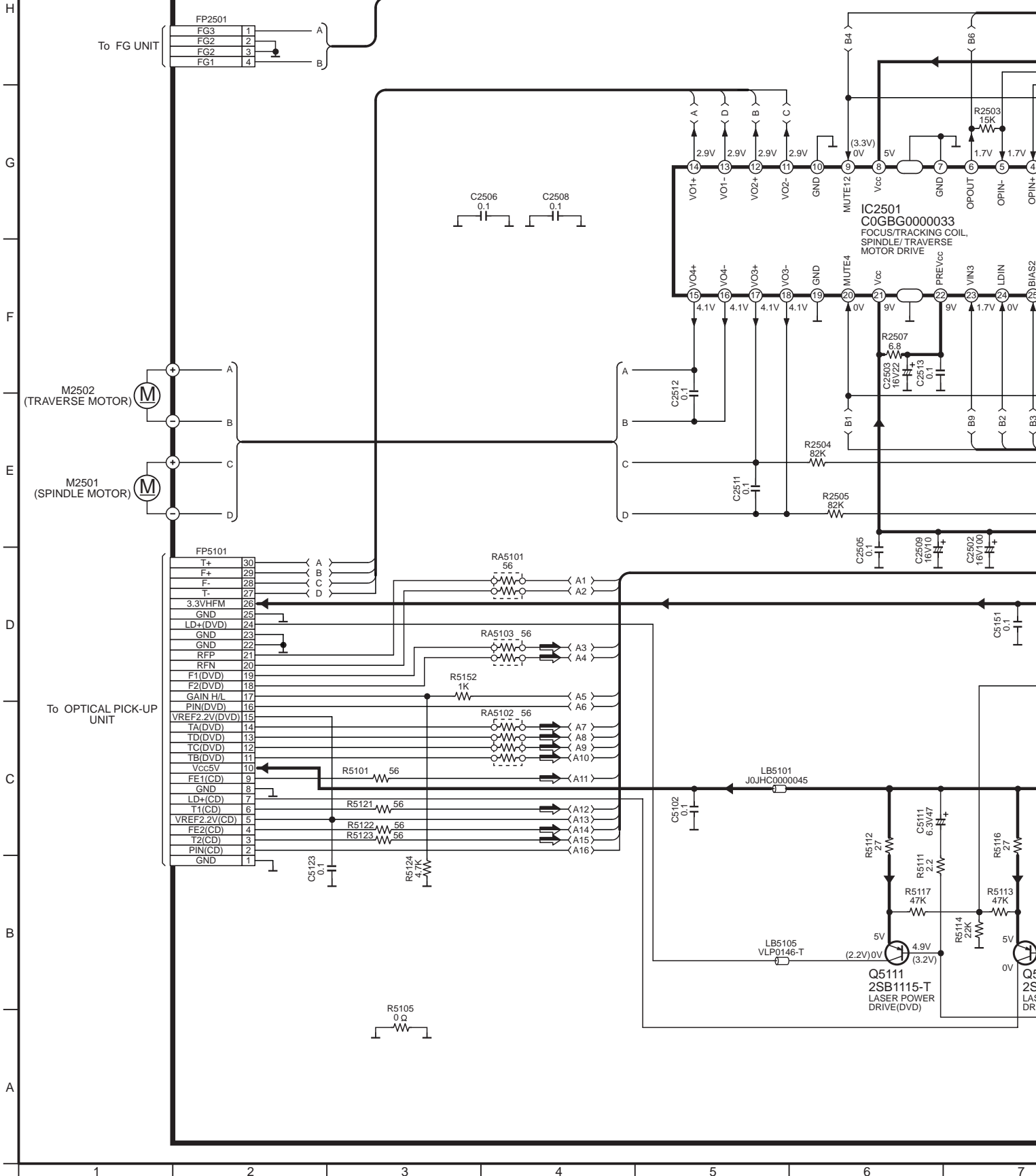
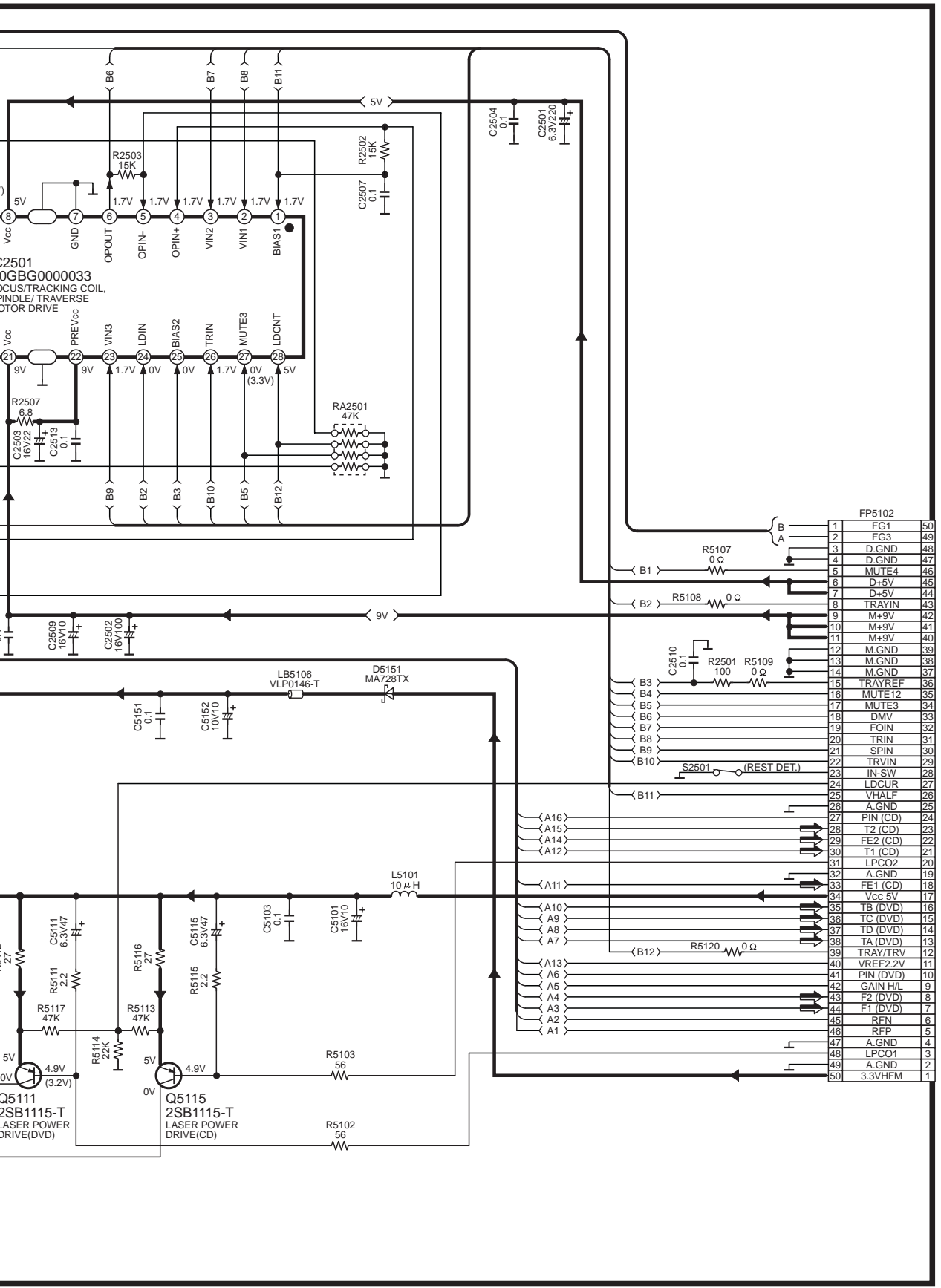

diagram as
 left corner in the schematic diagram.

→ : POSITIVE VOLTAGE LINE ⇨ : AUDIO/VIDEO SIGNAL LINE



FP5102	
1	FG1
2	FG3
3	D.GND
4	D.GND
5	MUTE4
6	D+5V
7	D+5V
8	TRAYIN
9	M+9V
10	M+9V
11	M+9V
12	M.GND
13	M.GND
14	M.GND
15	TRAYREF
16	MUTE12
17	MUTE3
18	DMV
19	FOIN
20	TRIN
21	SPIN
22	TRVIN
23	IN-SW
24	LDCUR
25	VHALF
26	A.GND
27	PIN (CD)
28	T2 (CD)
29	FE2 (CD)
30	T1 (CD)
31	LPCO2
32	A.GND
33	FE1 (CD)
34	Vcc 5V
35	TS (DVD)
36	TC (DVD)
37	TD (DVD)
38	TA (DVD)
39	TRAY/TRV
40	VREF2.2V
41	PIN (DVD)
42	GAIN H/L
43	F2 (DVD)
44	F1 (DVD)
45	RFN
46	RFP
47	A.GND
48	LPCO1
49	A.GND
50	3.3VHFM

To DVD MODULE (FEP) CIRCUIT(FP5201) on SCHEMATIC DIAGRAM-2/1,2-E-H

SL-DV290(E,E,GN) INTERFACE CIRCUIT DIAGRAM

SCHEMATIC DIAGRAM-2

B DVD MODULE(FEP) CIRCUIT

→ : POSITIVE VOLTAGE LINE ⇨ : AUDIO/VIDEO SIGNAL LINE

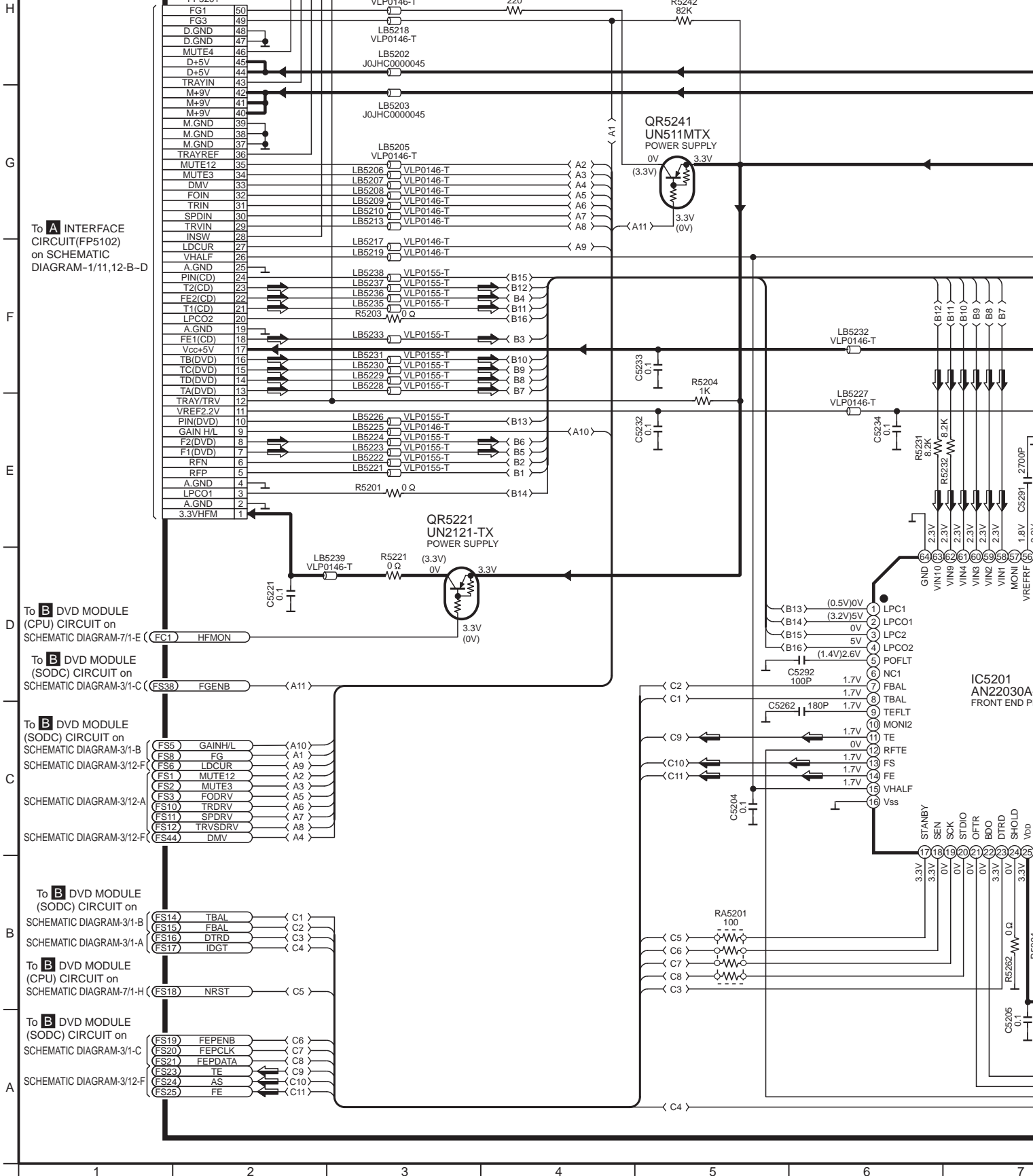

To **A** INTERFACE CIRCUIT(FP5102) on SCHEMATIC DIAGRAM-1/11,12-B-D

To **B** DVD MODULE (CPU) CIRCUIT on SCHEMATIC DIAGRAM-7/1-E

To **B** DVD MODULE (SODC) CIRCUIT on SCHEMATIC DIAGRAM-3/1-C

To **B** DVD MODULE (SODC) CIRCUIT on SCHEMATIC DIAGRAM-3/1-B

SCHEMATIC DIAGRAM-3/12-F

SCHEMATIC DIAGRAM-3/12-A

SCHEMATIC DIAGRAM-3/12-F

To **B** DVD MODULE (SODC) CIRCUIT on SCHEMATIC DIAGRAM-3/1-B

SCHEMATIC DIAGRAM-3/1-A

To **B** DVD MODULE (CPU) CIRCUIT on SCHEMATIC DIAGRAM-7/1-H

To **B** DVD MODULE (SODC) CIRCUIT on SCHEMATIC DIAGRAM-3/1-C

SCHEMATIC DIAGRAM-3/12-F

IC5201 AN22030A-FRONT END PROCESSOR

SCHEMATIC DIAGRAM-3

B DVD MODULE(SODC) CIRCUIT

→ : POSITIVE VOLTAGE LINE ⇨ : AUDIO/VIDEO SIGNAL LINE

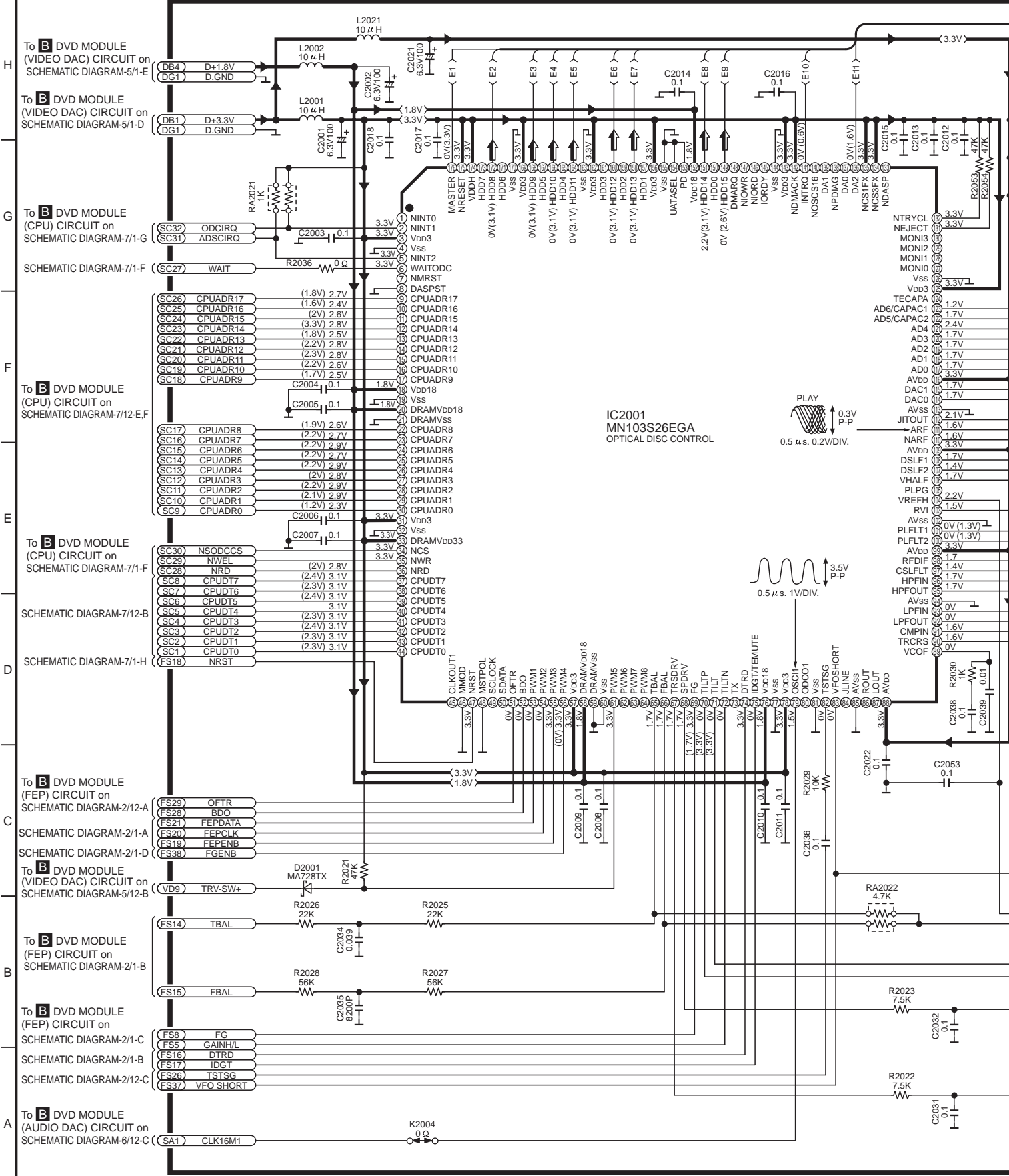

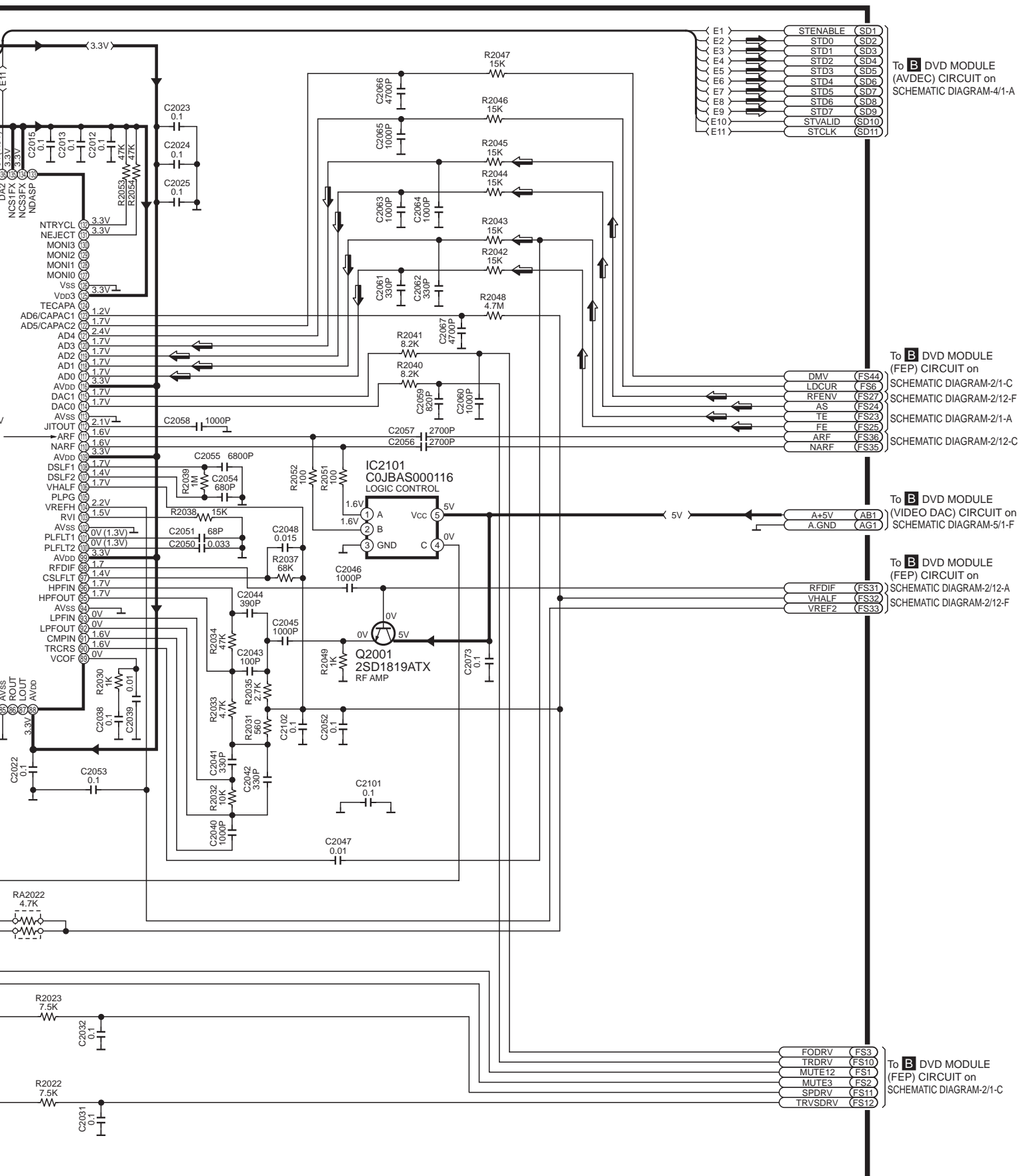

SL-DV290(EE,GN) DVD MODULE(SODC) CIRCUIT DIAGRAM

SCHEMATIC DIAGRAM-4

B DVD MODULE(AVDEC) CIRCUIT

→ : POSITIVE VOLTAGE LINE ⇨ : AUDIO/VIDEO SIGNAL LINE ⇨ : AUDIO SIGNAL LINE

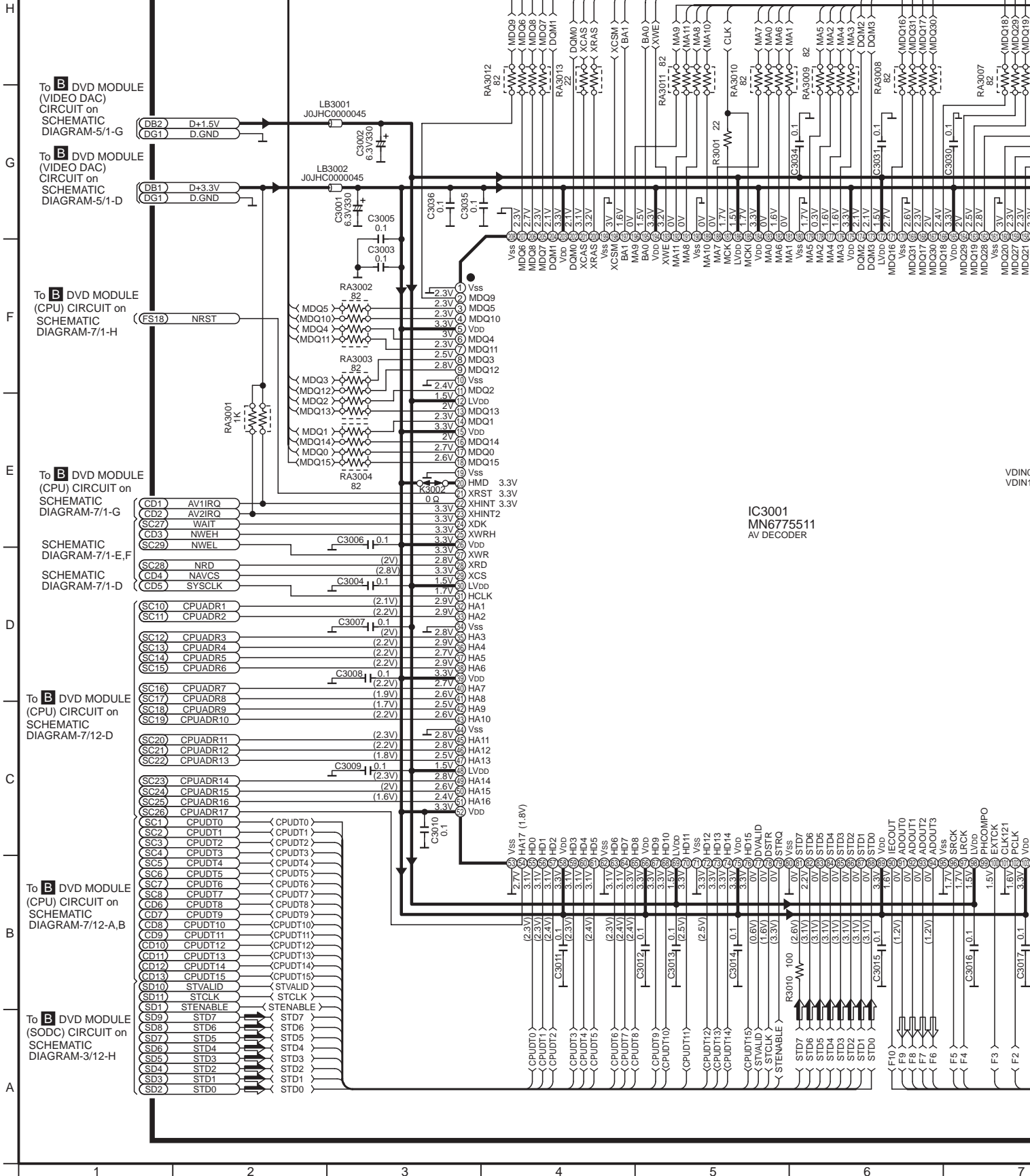

IC3001
MN6775511
AV DECODER

VDIN0/
VDIN1/

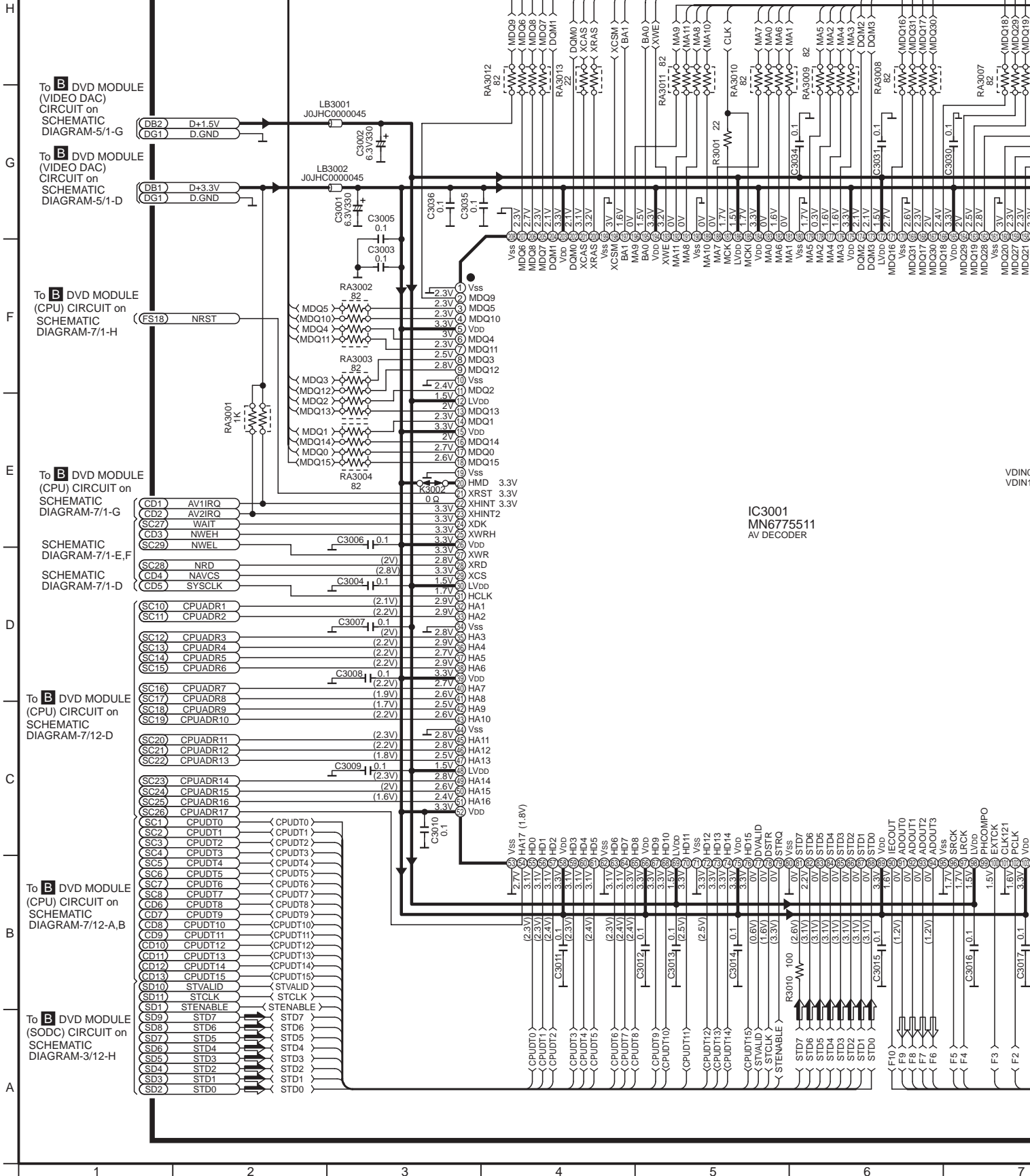

→ :AUDIO SIGNAL LINE → :VIDEO SIGNAL LINE

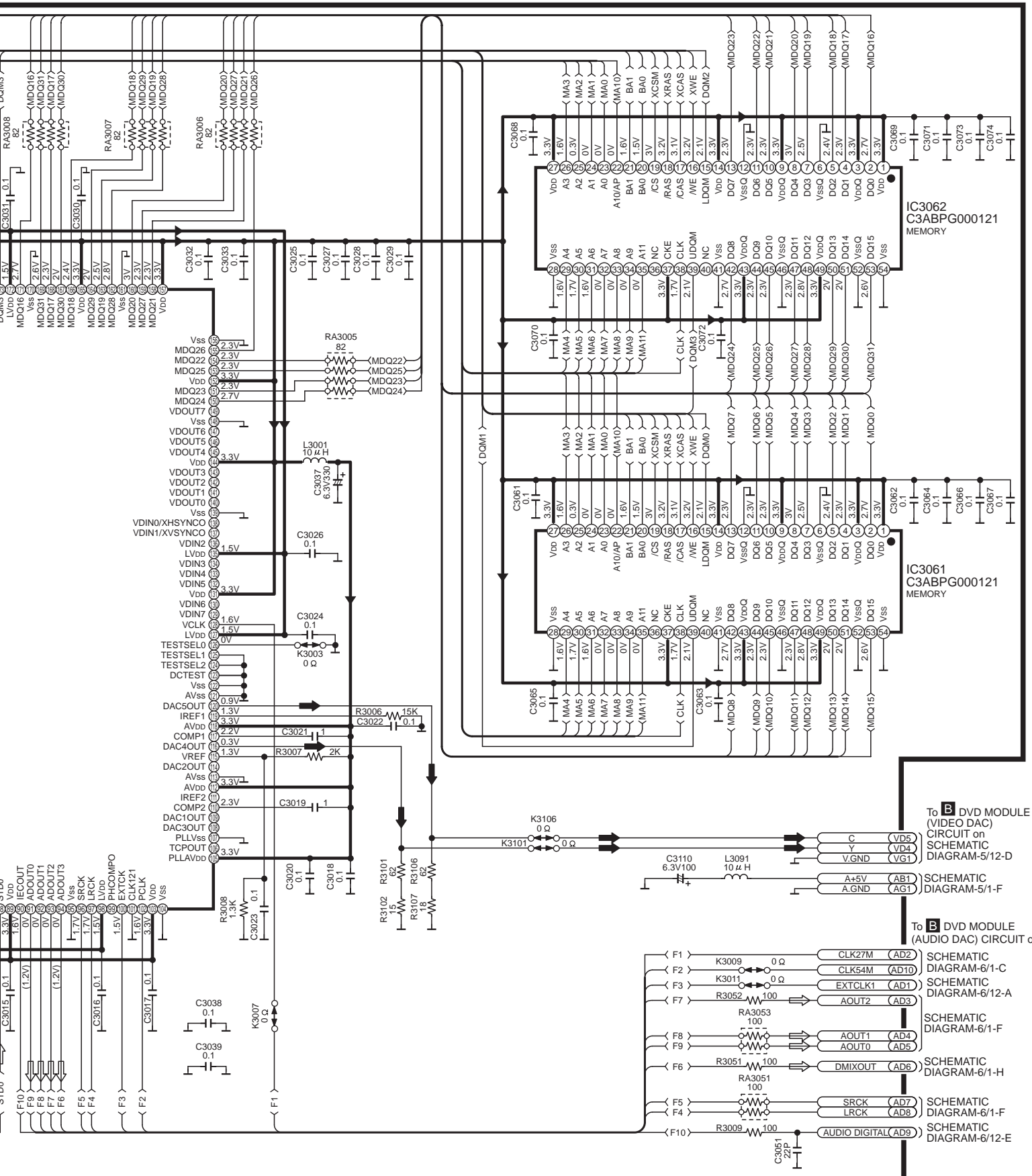

SL-DV290(EE,GN) DVD MODULE(AVDEC) CIRCUIT DIAGRAM



SCHEMATIC DIAGRAM-5

B DVD MODULE(VIDEO DAC) CIRCUIT

→ : POSITIVE VOLTAGE LINE → : VIDEO SIGNAL LINE

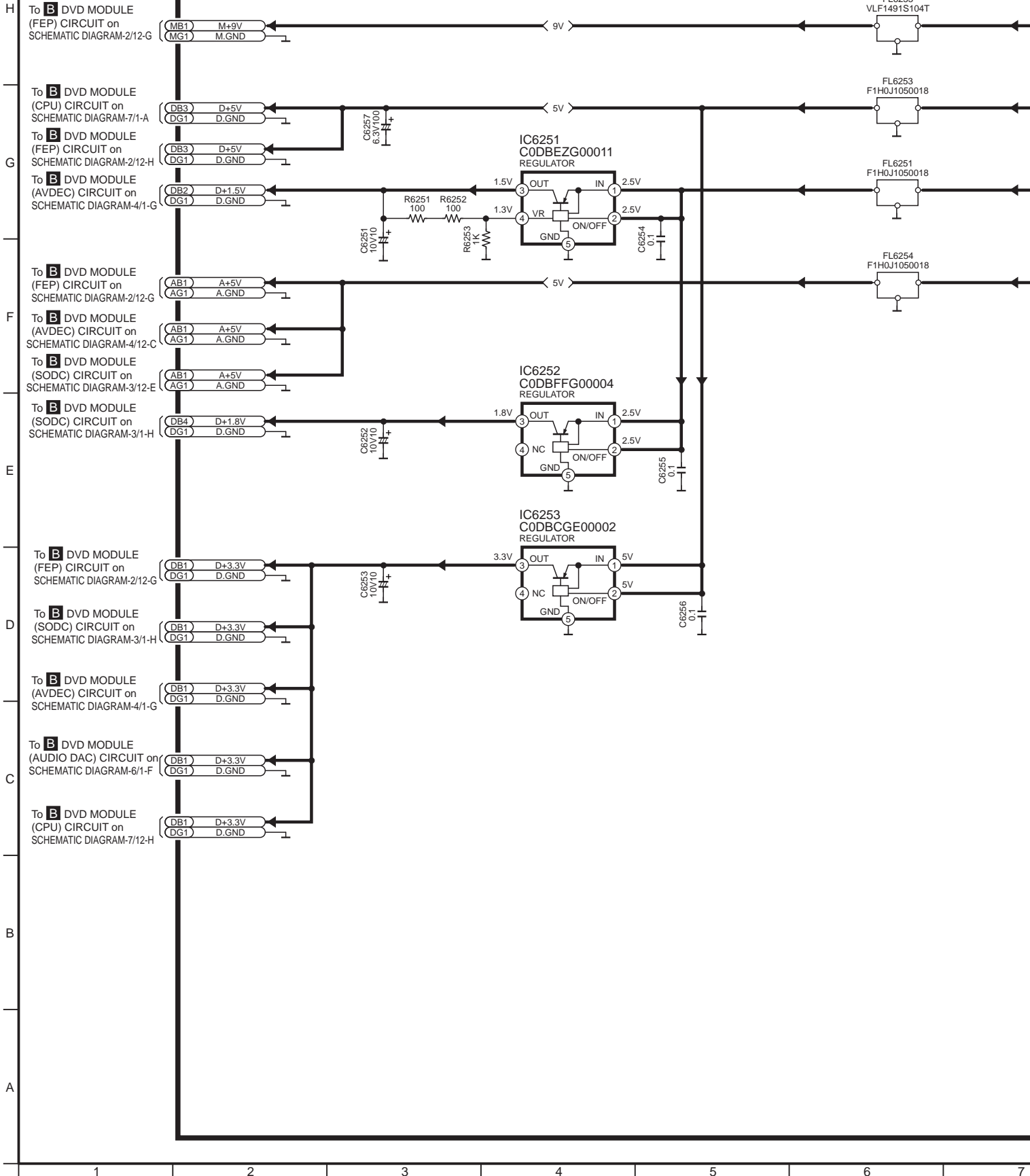

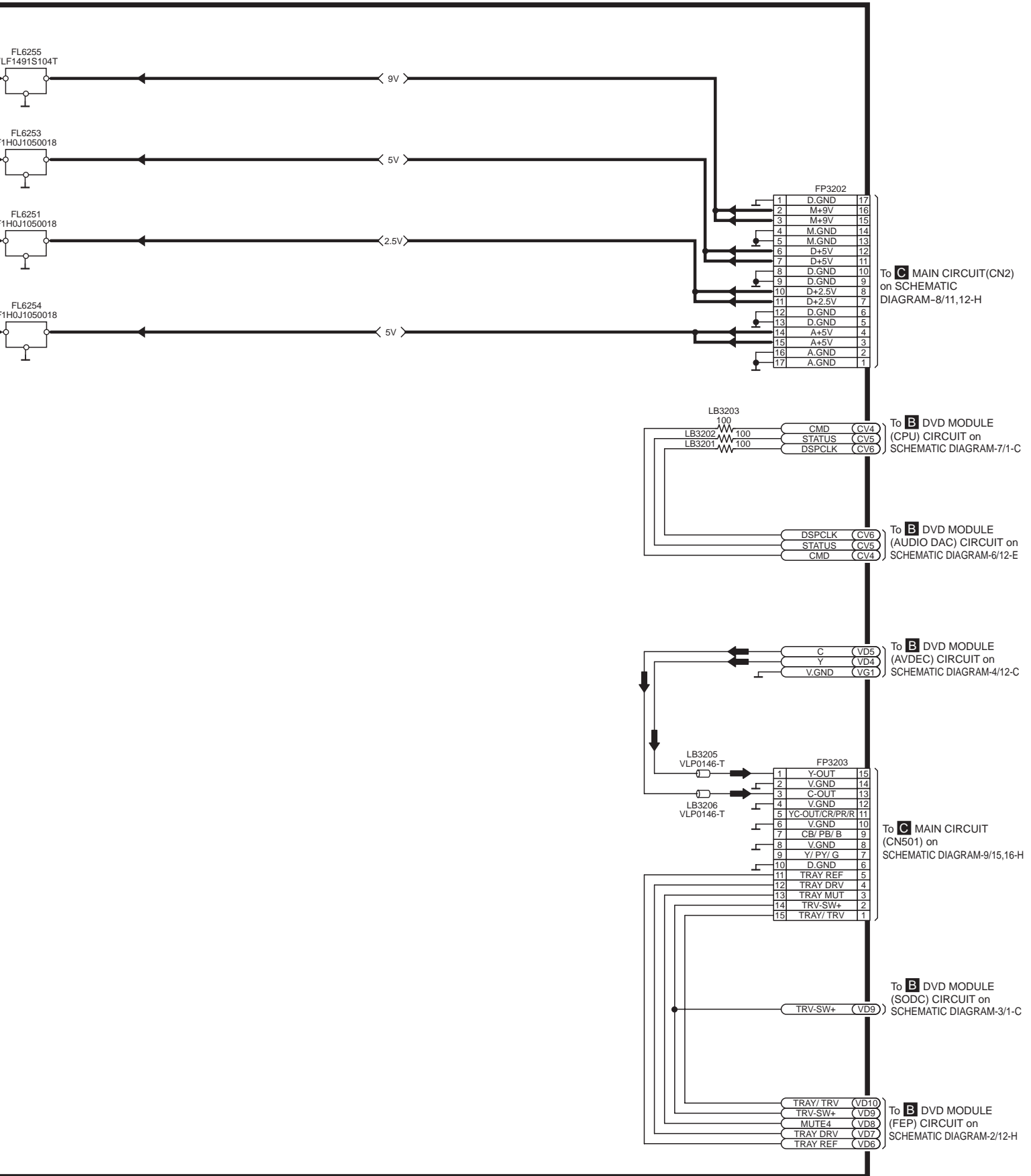



SL-DV290(E,E,GN) DVD MODULE(VIDEO DAC) CIRCUIT DIAGRAM

SCHEMATIC DIAGRAM-6

B DVD MODULE(AUDIO DAC) CIRCUIT

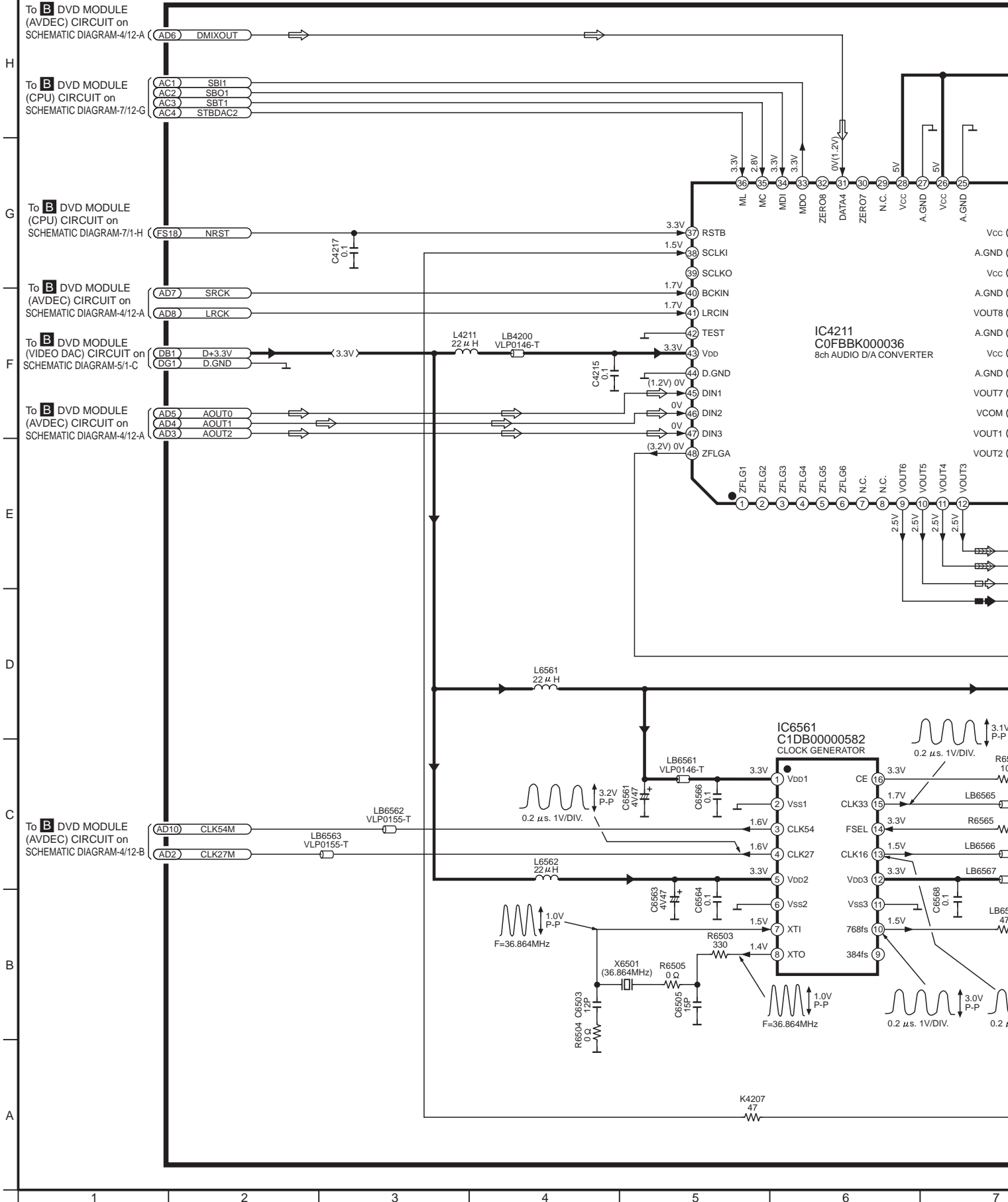
→ : POSITIVE VOLTAGE LINE ⇨ : AUDIO SIGNAL LINE ⇨⇨ : SURROUND SP. SIGNAL



 :SURROUND SP. SIGNAL LINE
  :CENTER SP. SIGNAL LINE
  :SUB WOOFER SIGNAL LINE

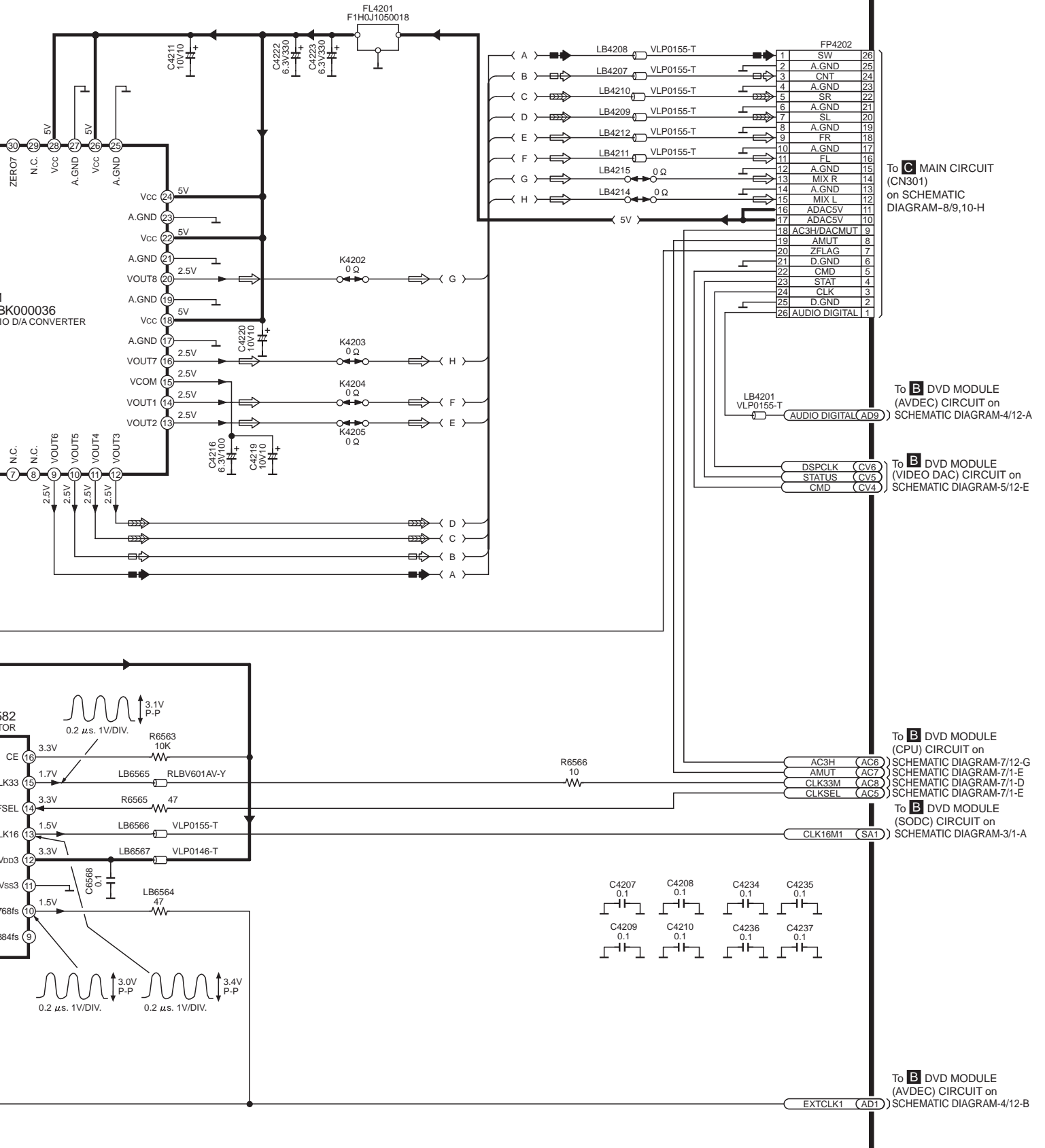

To **C** MAIN CIRCUIT (CN301) on SCHEMATIC DIAGRAM-8/9,10-H

To **B** DVD MODULE (AVDEC) CIRCUIT on SCHEMATIC DIAGRAM-4/12-A

To **B** DVD MODULE (VIDEO DAC) CIRCUIT on SCHEMATIC DIAGRAM-5/12-E

To **B** DVD MODULE (CPU) CIRCUIT on SCHEMATIC DIAGRAM-7/12-G
 To **B** DVD MODULE (SODC) CIRCUIT on SCHEMATIC DIAGRAM-7/1-E
 To **B** DVD MODULE (SODC) CIRCUIT on SCHEMATIC DIAGRAM-7/1-D
 To **B** DVD MODULE (SODC) CIRCUIT on SCHEMATIC DIAGRAM-7/1-E

To **B** DVD MODULE (SODC) CIRCUIT on SCHEMATIC DIAGRAM-3/1-A

To **B** DVD MODULE (AVDEC) CIRCUIT on SCHEMATIC DIAGRAM-4/12-B

SL-DV290(AE,GN) DVD MODULE(AUDIO DAC) CIRCUIT DIAGRAM

SCHEMATIC DIAGRAM-7

B DVD MODULE(CPU) CIRCUIT

→ : POSITIVE VOLTAGE LINE

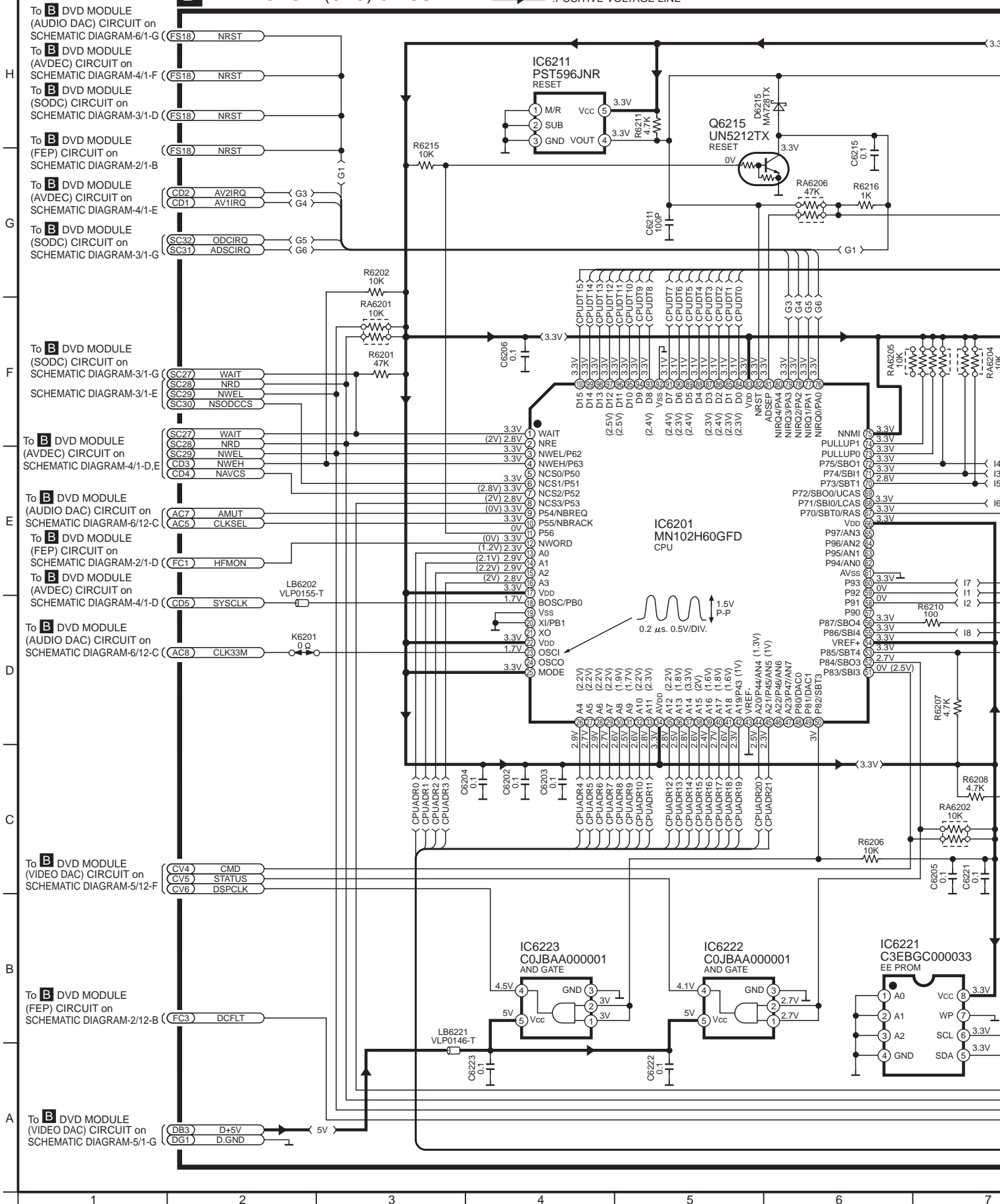

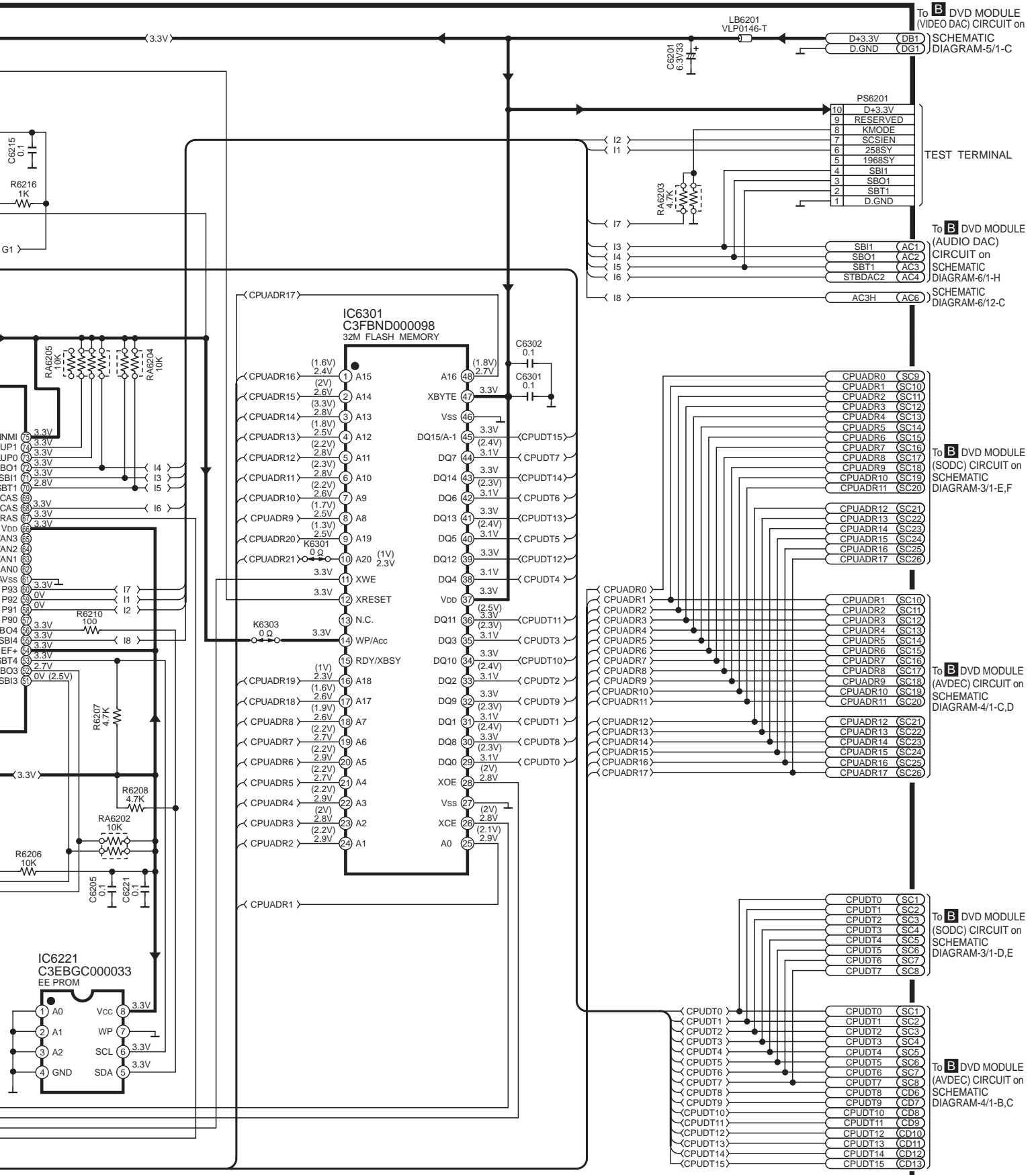

SL-DV290(EE,GN) DVD MODULE(CPU) CIRCUIT DIAGRAM

SCHEMATIC DIAGRAM-8

- : POSITIVE VOLTAGE LINE
- ⇨ : AUDIO SIGNAL LINE
- ⇨⇨ : SURROUND SP. SIGNAL LINE
- ⇨⇨⇨ : CENTER SP. SIGNAL LINE
- ⇨⇨⇨⇨ : SUB WOOFER SIGNAL LINE

F CLAMP SW CIRCUIT

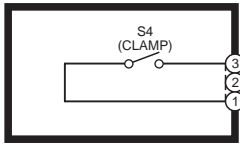

G BOTTOM SW CIRCUIT

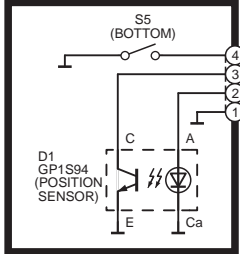

D OPERATION CIRCUIT

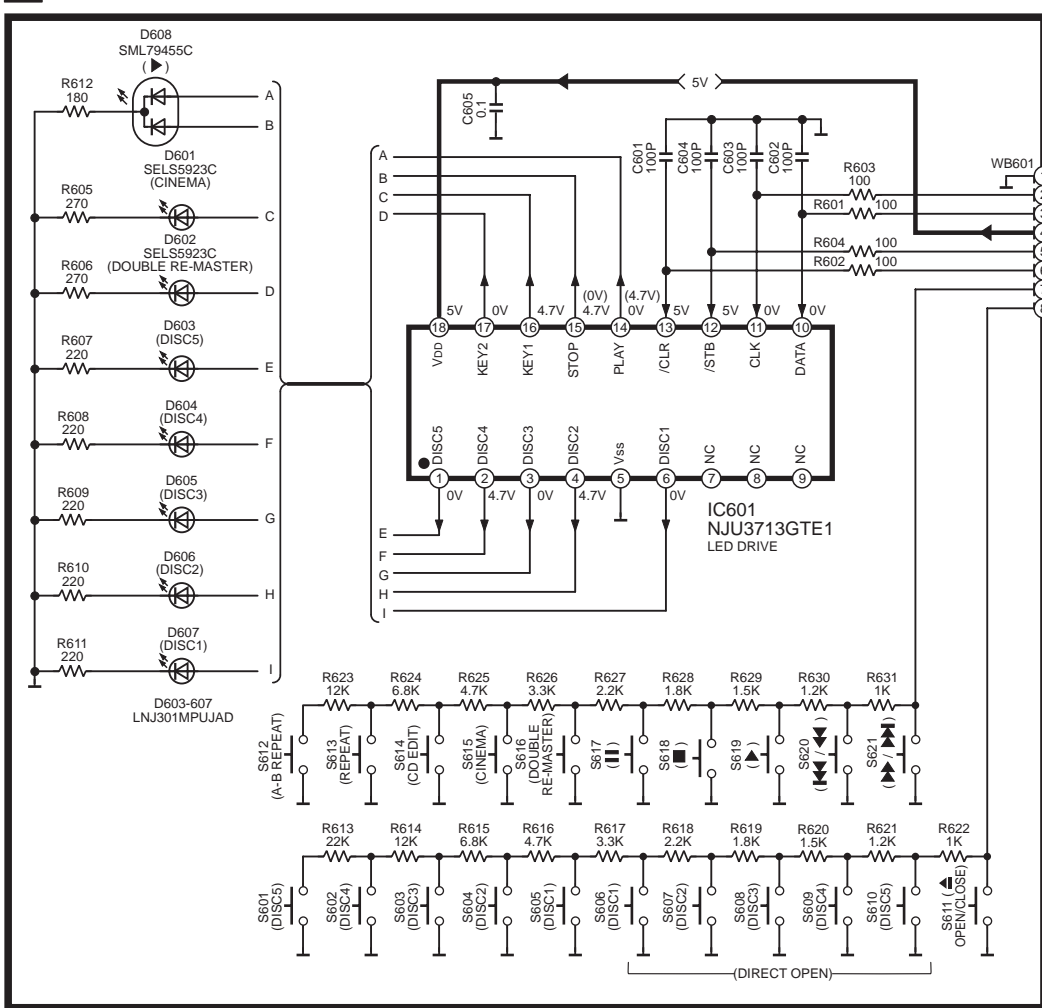

E LOADING MOTOR CIRCUIT

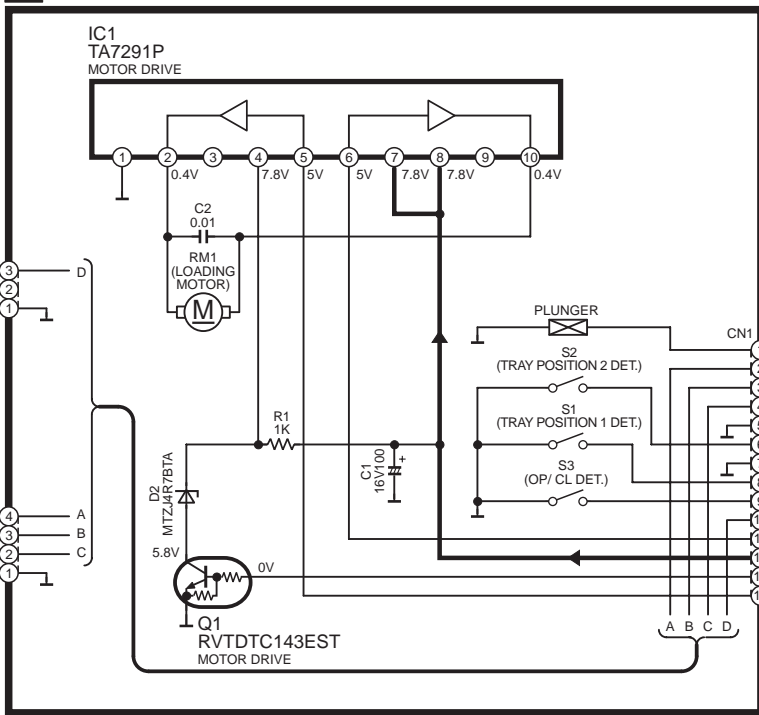

C MAIN CIRCUIT

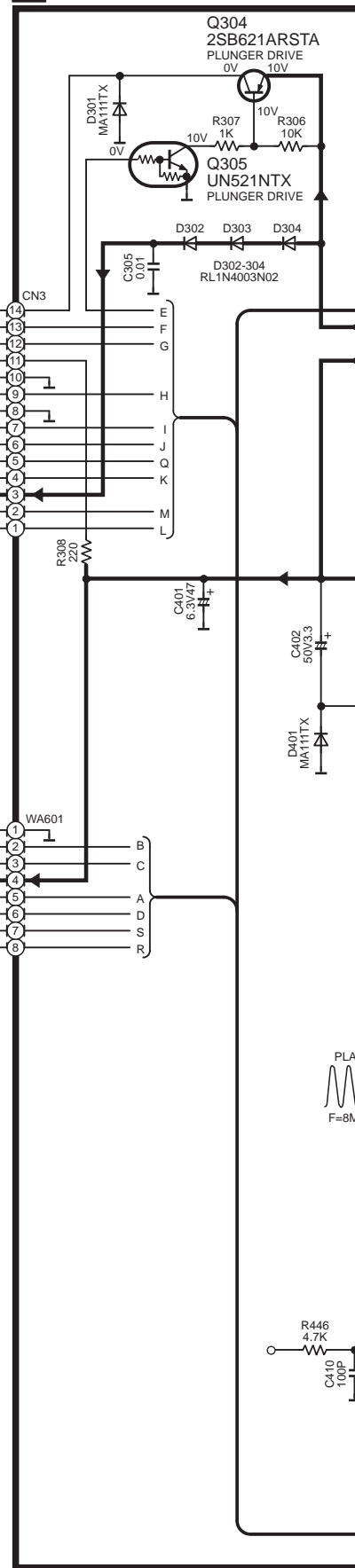

1

2

3

4

5

6

7

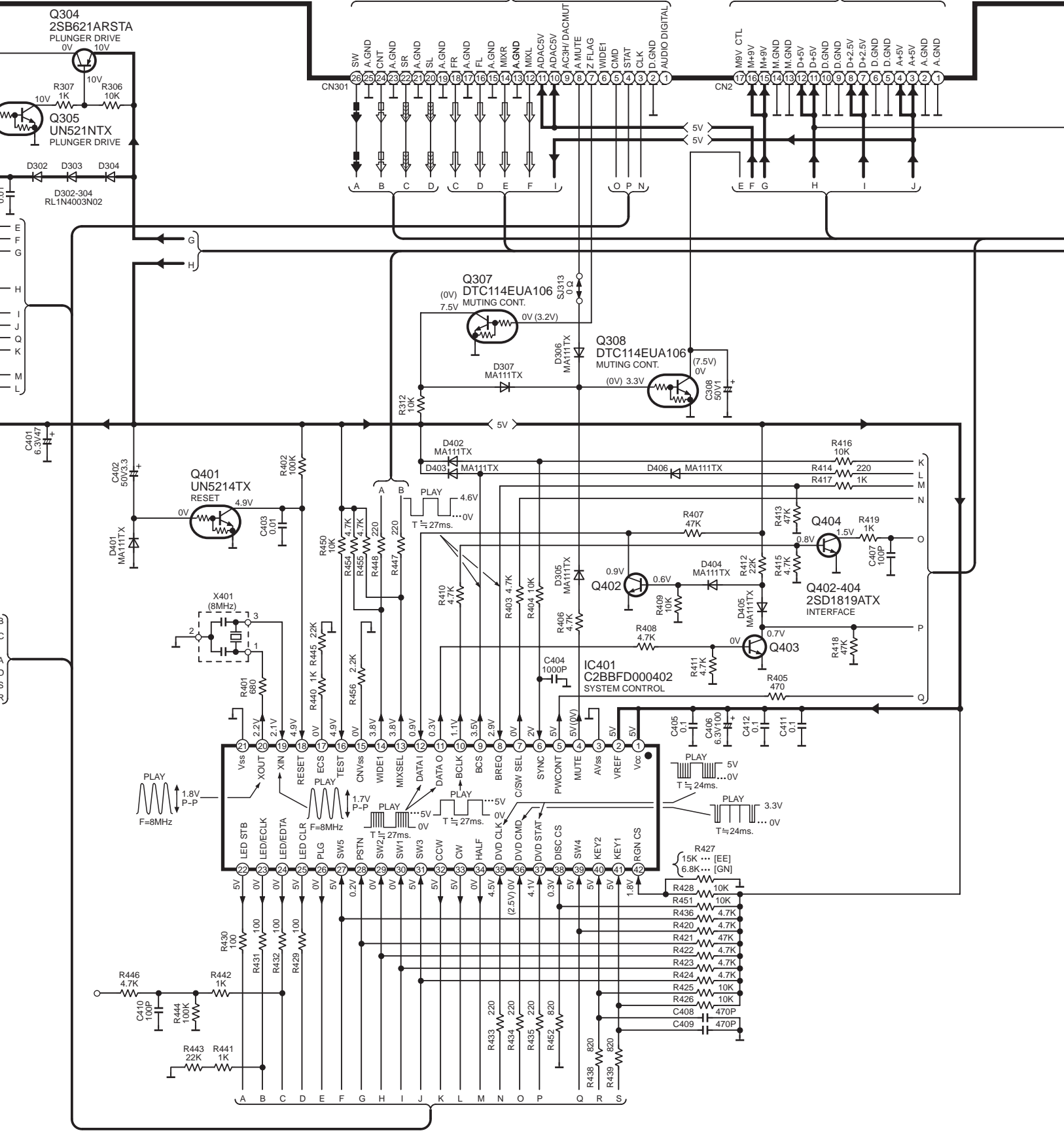

SL-DV290(EE,GN) LOADING MOTOR,CLAMP SW,BOTTOM SW,OPERATION,MAIN CIRCUIT DIAGRAM

SCHEMATIC DIAGRAM-9

C MAIN CIRCUIT

To **B** MODULE CIRCUIT(FP3203)
on SCHEMATIC DIAGRAM-5/12-C

→ : POSITIVE VOLTAGE LINE ⇨ : AUDIO SIGNAL LINE ⇩ : VIDEO SIGNAL LINE

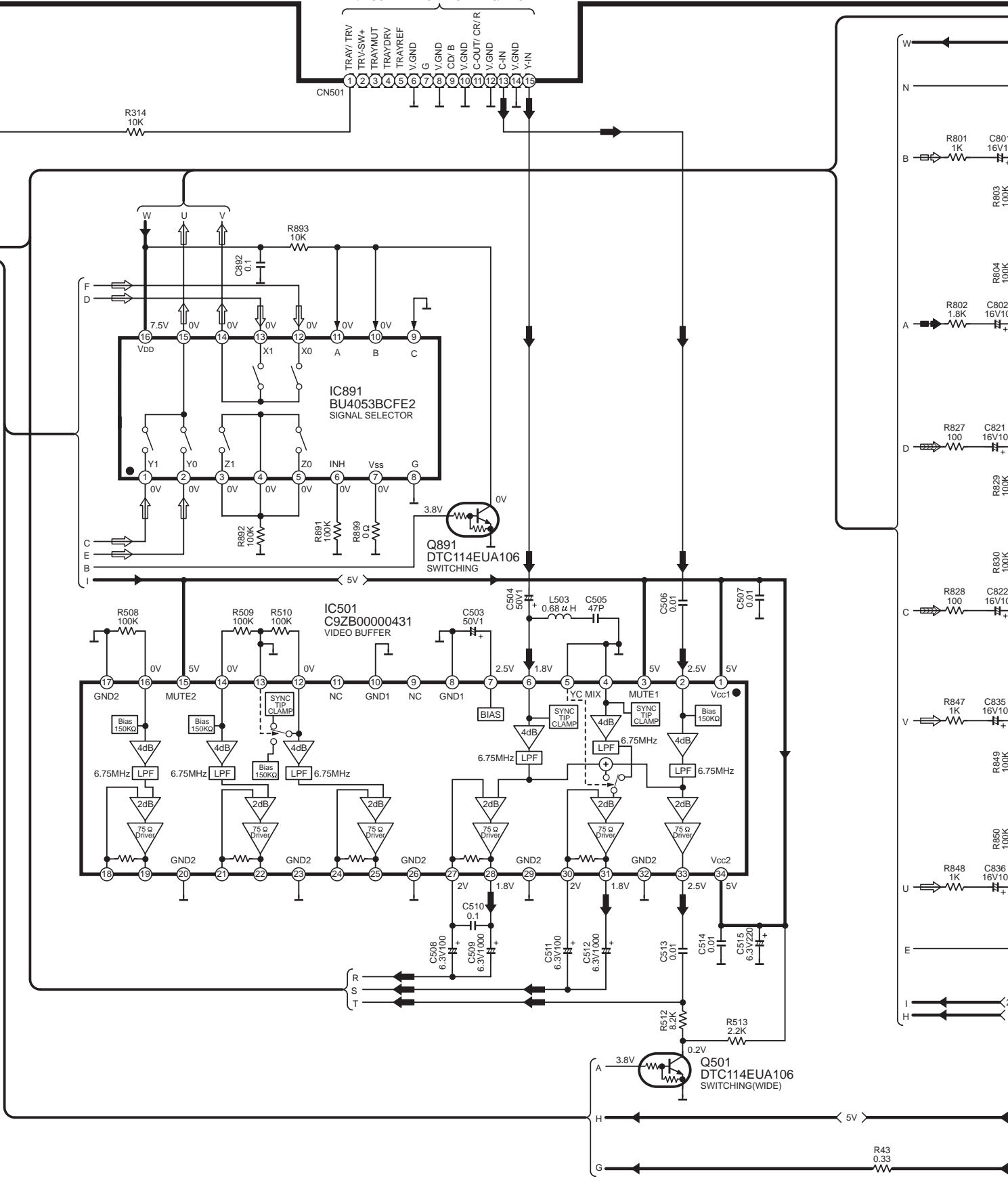

IO SIGNAL LINE \blacktriangleright : VIDEO SIGNAL LINE \blacktriangleright : SURROUND SP. SIGNAL LINE \square : CENTER SP. SIGNAL LINE \blacktriangleright : SUB WOOFER SIGNAL LINE

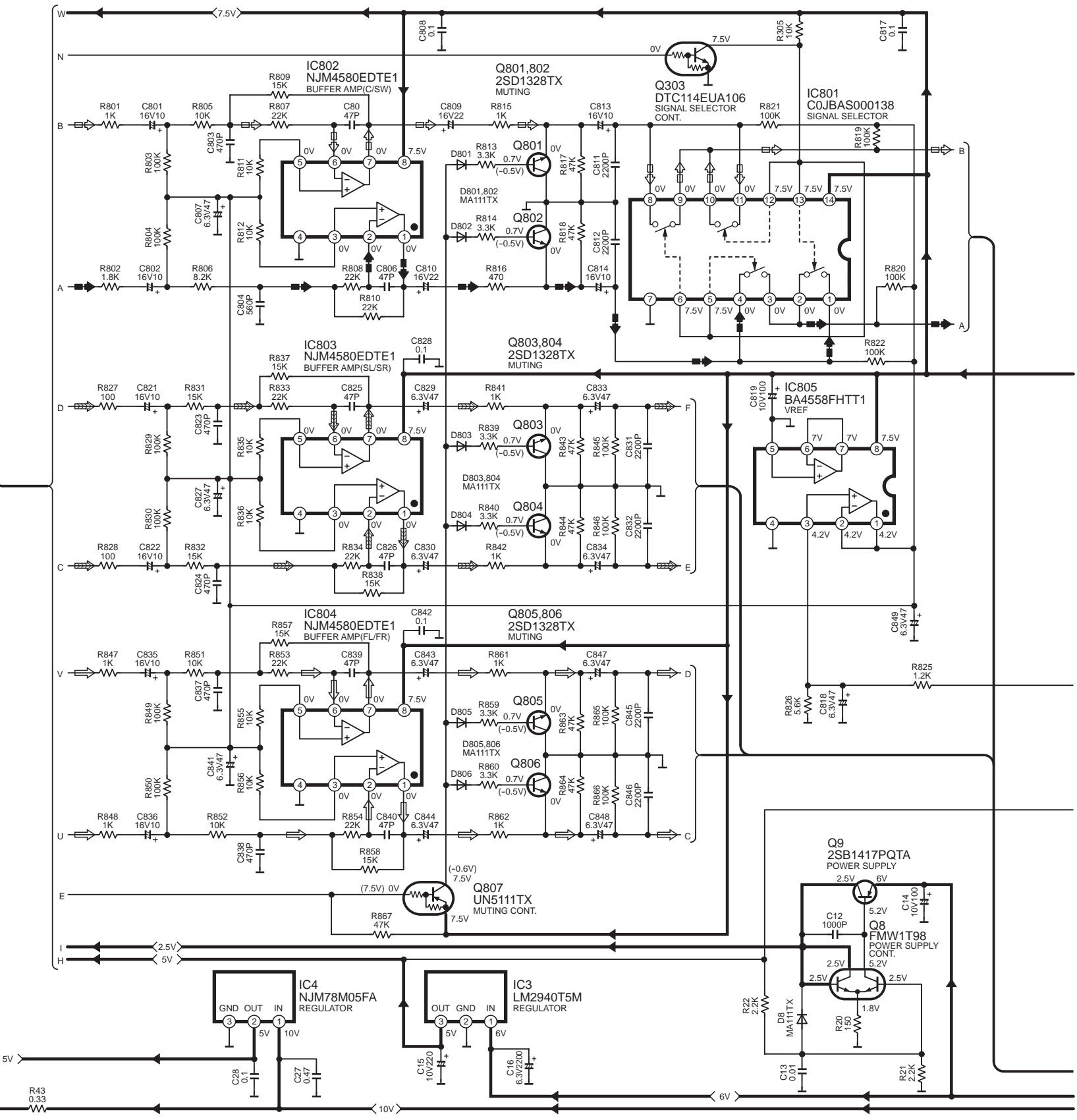

SL-DV290(EE,GN) MAIN CIRCUIT DIAGRAM

SCHEMATIC DIAGRAM-10

C MAIN CIRCUIT

: POSITIVE VOLTAGE LINE
 : AUDIO SIGNAL LINE
 : CENTER SP. SIGNAL LINE
 : VIDEO SIGNAL LINE
 : SUB WOOFER SIGNAL LINE
 : SURROUND SP. SIGNAL LINE

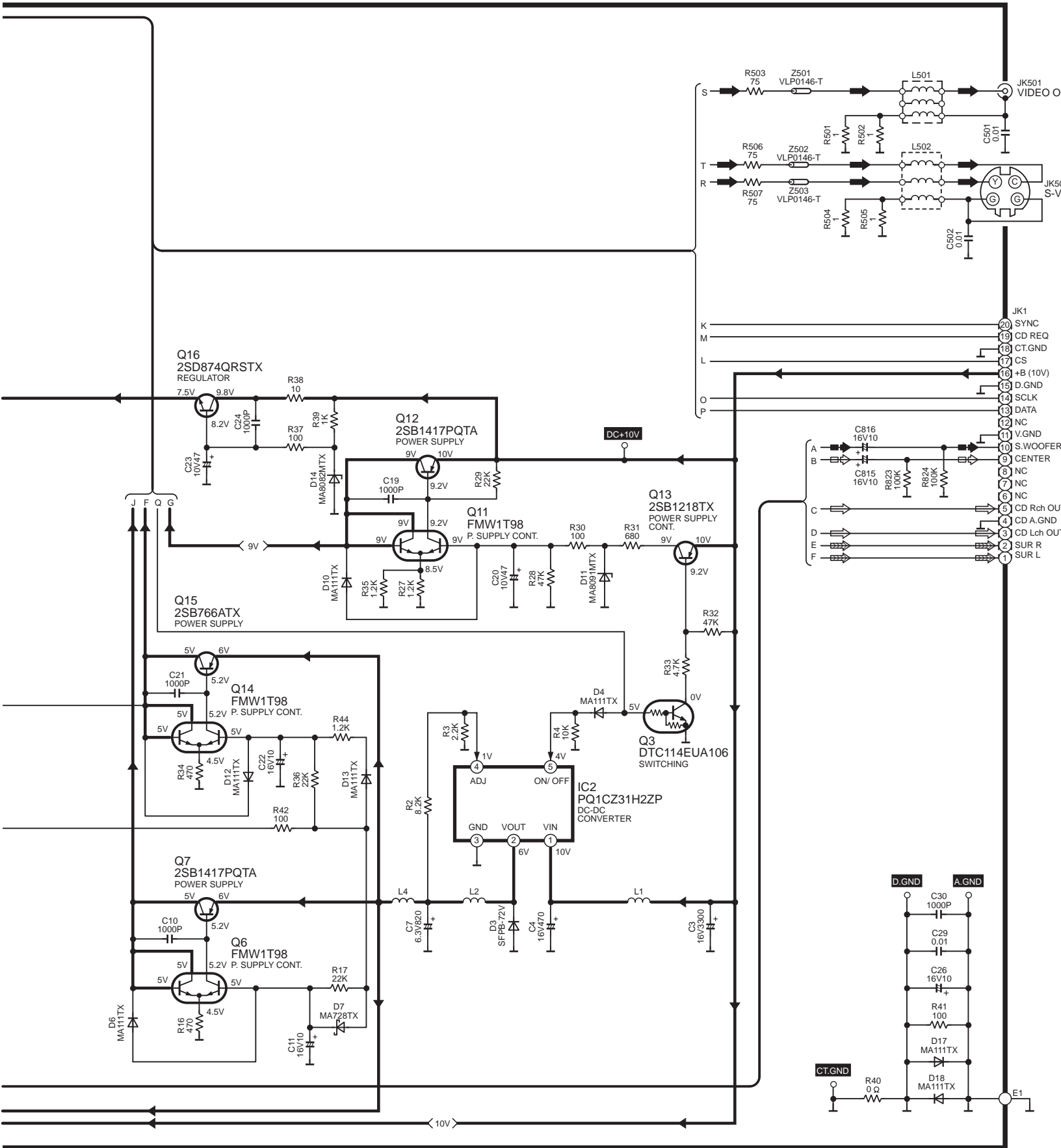

SL-DV290(EE,GN) MAIN CIRCUIT DIAGRAM

ND SP. SIGNAL LINE

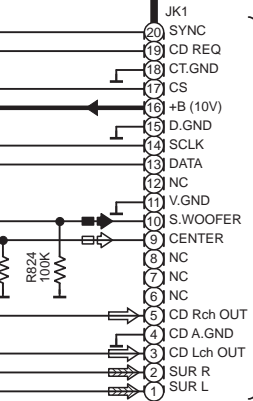
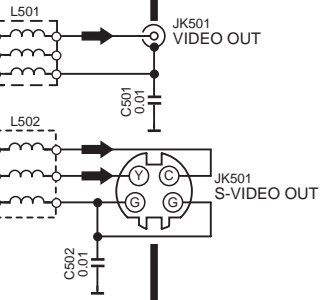

To SOUND PROCESSOR(SH-DV290) & CASSETTE DECK(RS-DV290)

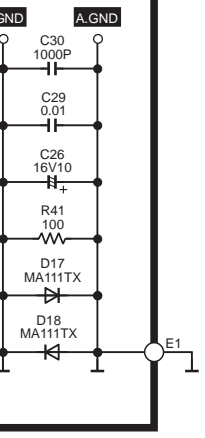

IN CIRCUIT DIAGRAM

H

G

F

E

D

C

B

A

C1DB00000582	16PIN	C9ZB00000431	34PIN
C2BBFD000402	42PIN	BU4053BCFE2	16PIN
NJM4580EDTE1	8PIN	C3ABPG000121	54PIN
NJU3713GTE1	18PIN		

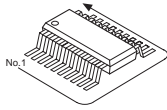

C0FBBK000036	48PIN	MN103S26EGA	176PIN
MN102H60GFD	100PIN	AN22030A-VT	64PIN
MN6775511	208PIN		

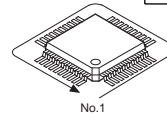

<p>C0JBAS000138</p>	<p>C3FBND000098</p>	<p>TA7291P</p>	<p>PST596JNR C0JBAA000001 C0JBAS000116</p>	<p>PQ1CZ31H2ZP C0DBEZG00011 C0DBFFG00004 C0DBCGE00002</p>	<p>BA4558FH1T1 C3EBGC000033</p>
<p>NJM78M05FA</p>	<p>C0GBG0000033</p>	<p>LM2940T5M</p>	<p>2SB1417PQTA</p>	<p>2SB1218TX UN2121-TX 2SD1328TX UN5111TX 2SD1819ATX UN5212TX DTC114EUA106 UN5214TX UN511MTX UN521NTX UN5211TX</p>	
<p>FMW1T98</p>	<p>2SB1115-T 2SB766ATX 2SD874QRSTX</p>	<p>2SB621ARSTA</p>	<p>RVTDTTC143EST</p>	<p>MA728TX</p>	<p>MA111TX SFPB-72V</p>
<p>MA8082MTX MA8091MTX</p>	<p>RL1N4003N02</p>	<p>SML79455C</p>	<p>LNJ301MPUJAD</p>	<p>SELS5923C</p>	<p>MTZJ4R7BTA</p>
<p>GP1S94</p>					

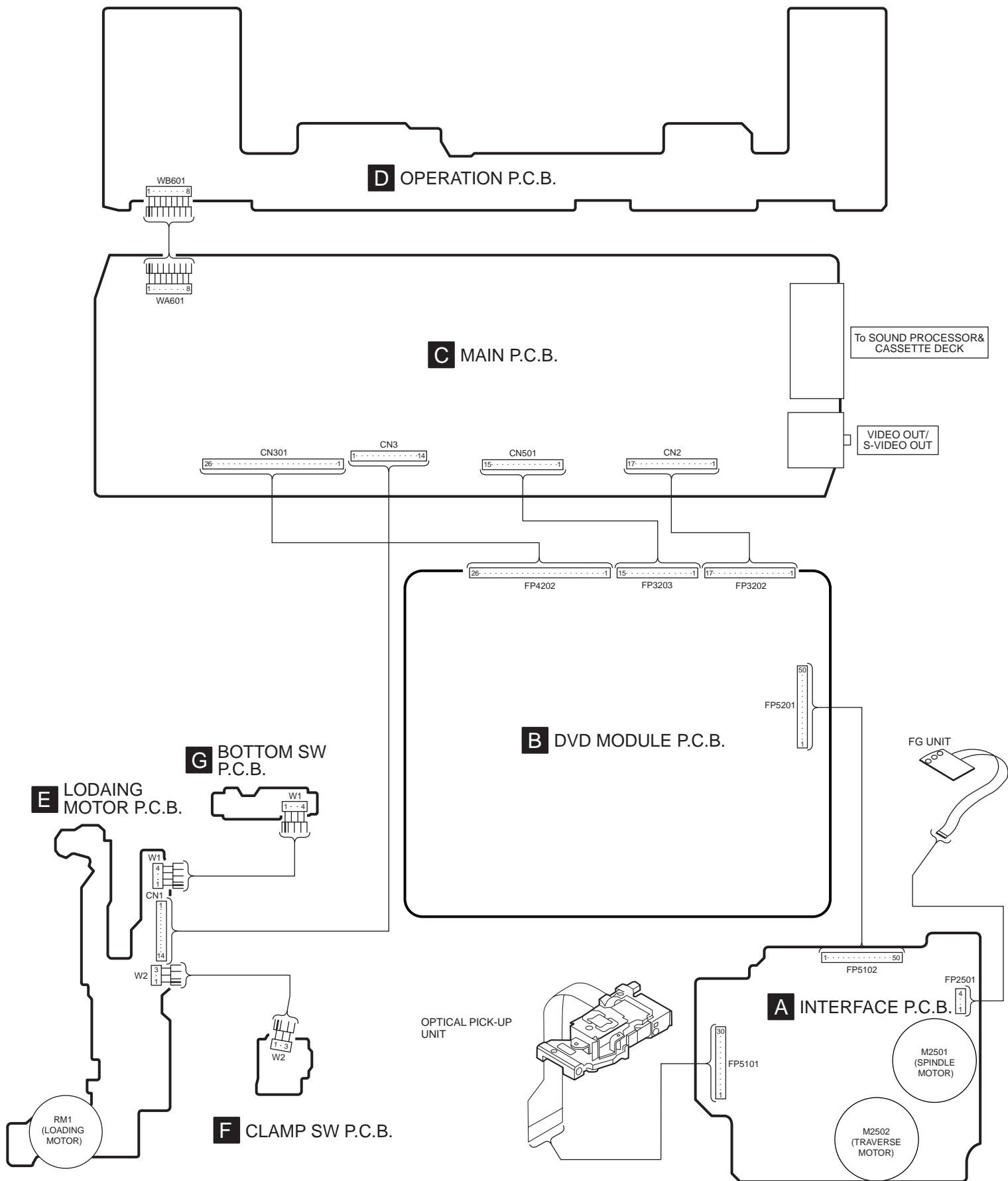

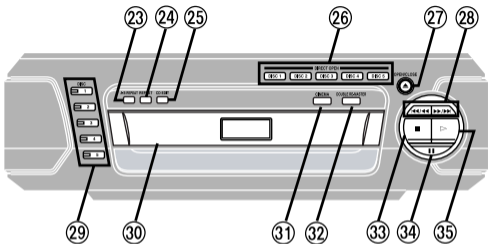

- ②③ **A-B repeat button (A-B REPEAT)**
- ②④ **Repeat play button (REPEAT)**
- ②⑤ **CD edit button (CD EDIT)**
- ②⑥ **Disc direct open buttons (DIRECT OPEN, DISC 1–DISC 5)**
- ②⑦ **Disc tray open/close button (▲, OPEN/CLOSE)**
- ②⑧ **Skip/search buttons (|◀◀/◀◀, ▶▶/▶▶|)**
- ②⑨ **Disc select buttons and indicators (DISC, 1–5)**
Green: Indicates that the tray is ready to play its disc or to be opened.
- ③⑩ **Disc tray**
- ③① **Cinema mode button and indicator (CINEMA)**
- ③② **Double re-master button and indicator (DOUBLE RE-MASTER)**
- ③③ **Stop button (■)**
- ③④ **Pause button (||)**
- ③⑤ **Play button and indicator (▷)**
The colour of the indicator depends on the operation taking place.
If stopped: orange
If playing: green
If paused: flashes green
When the resume function is on: flashes orange

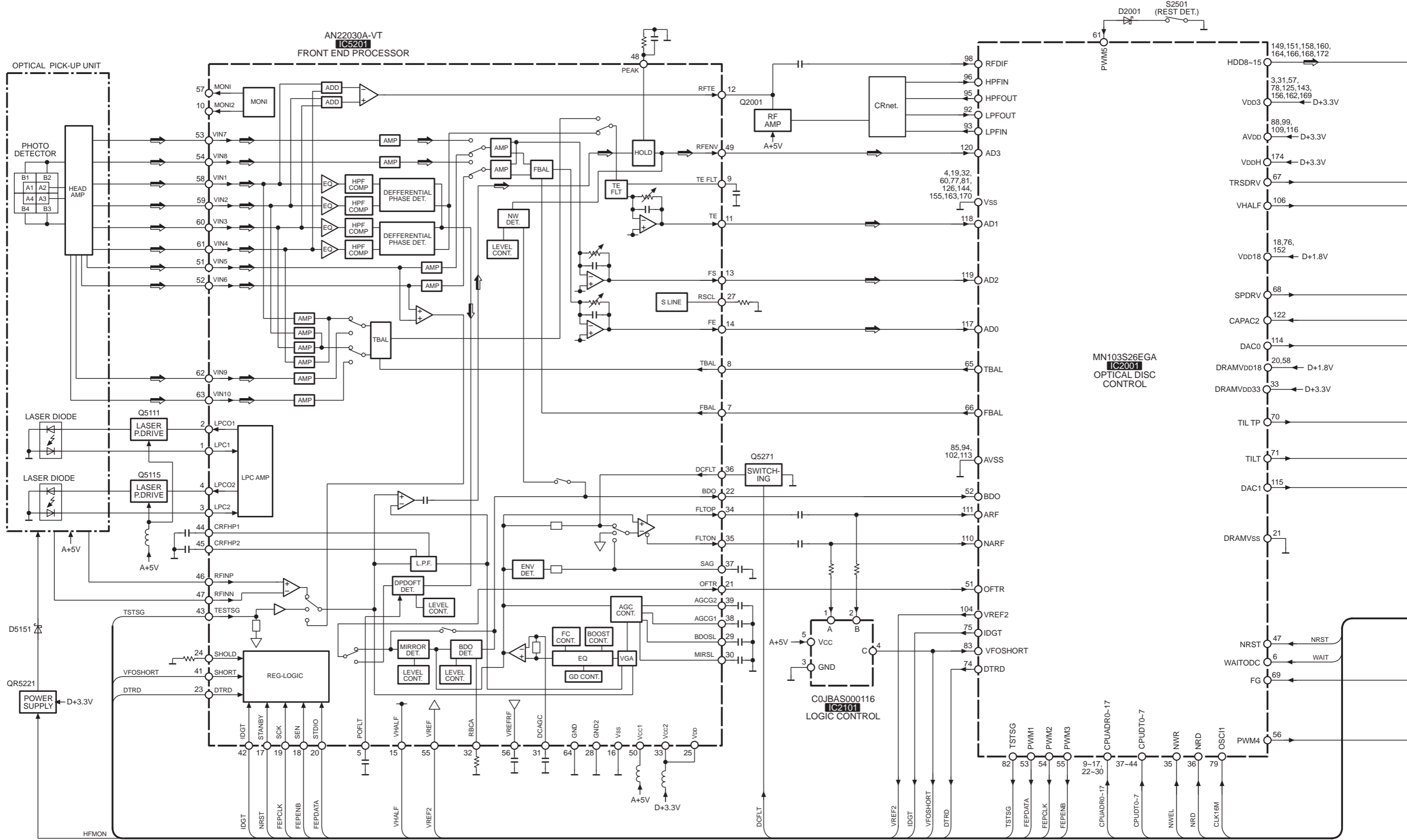

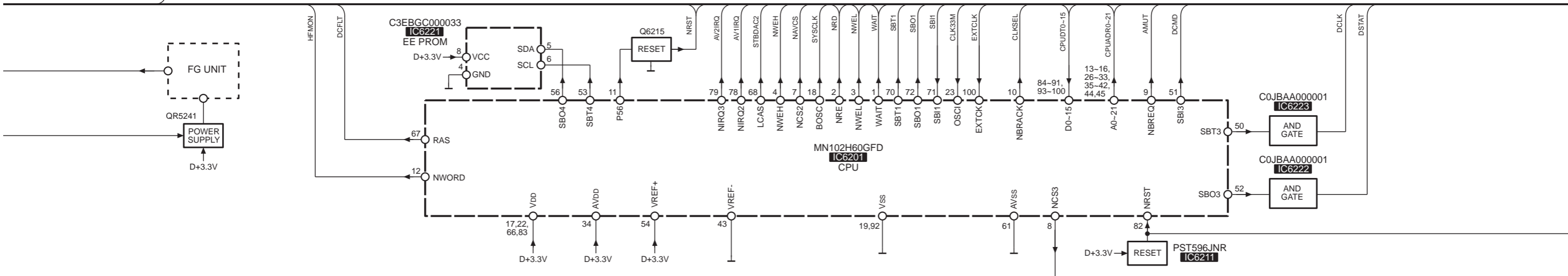
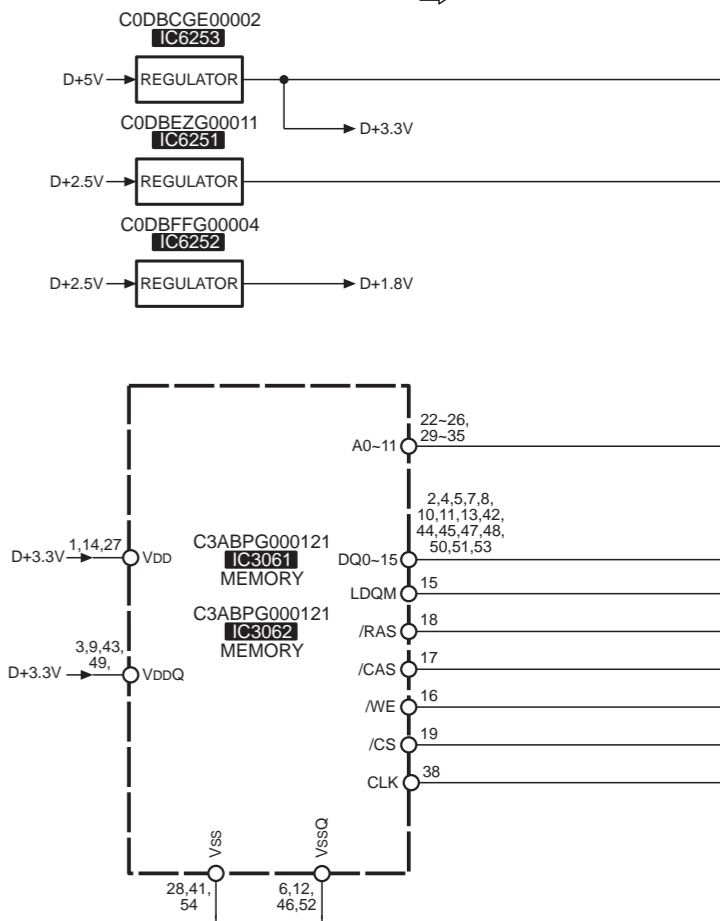
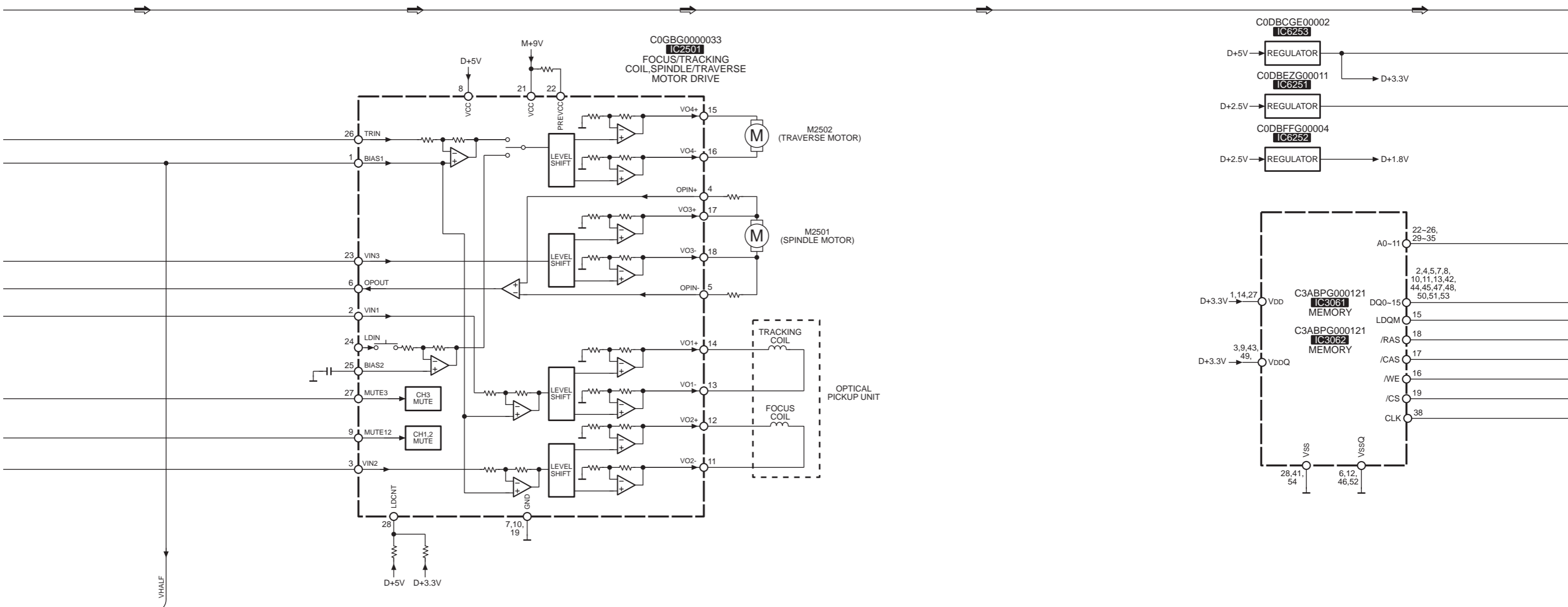

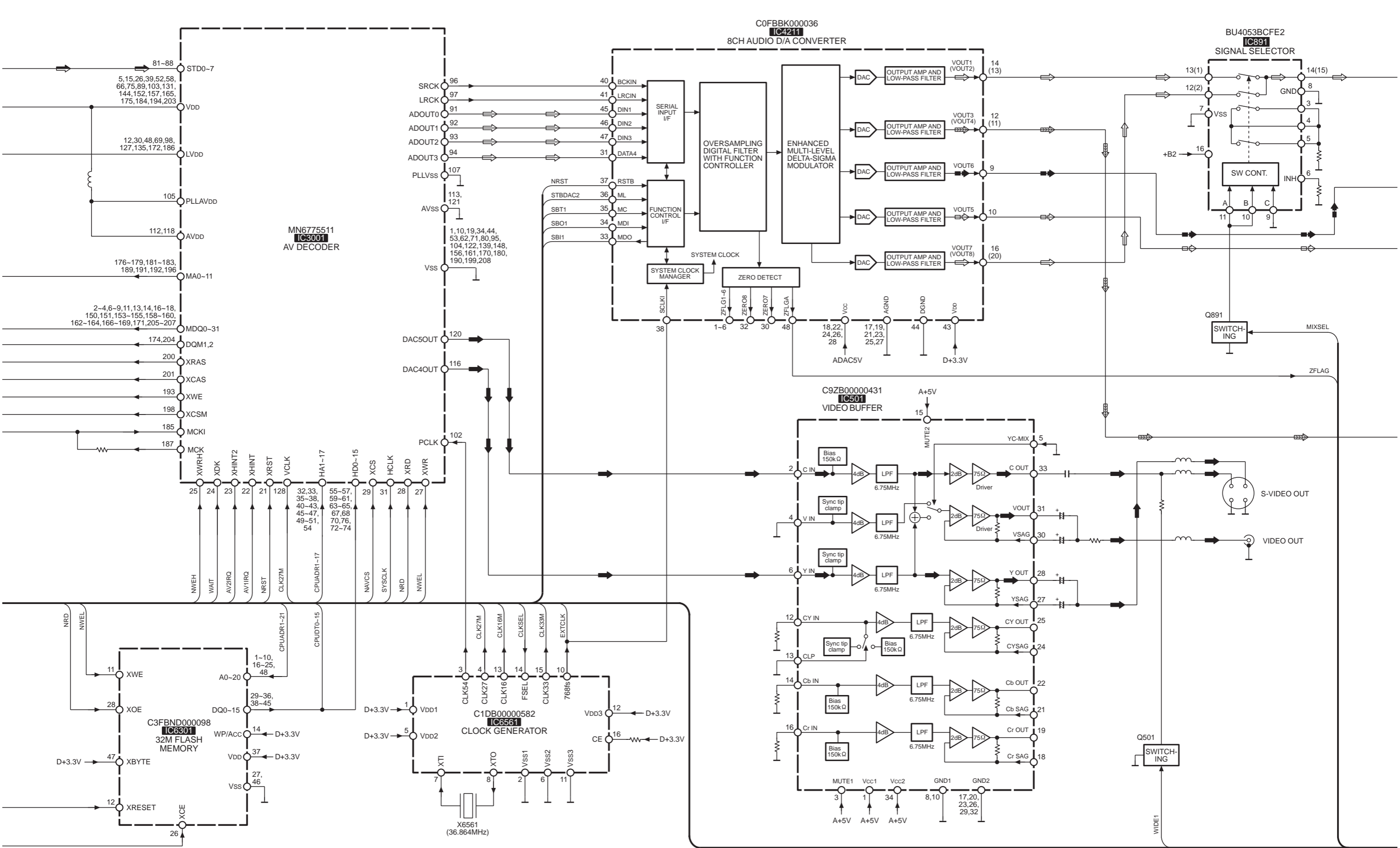

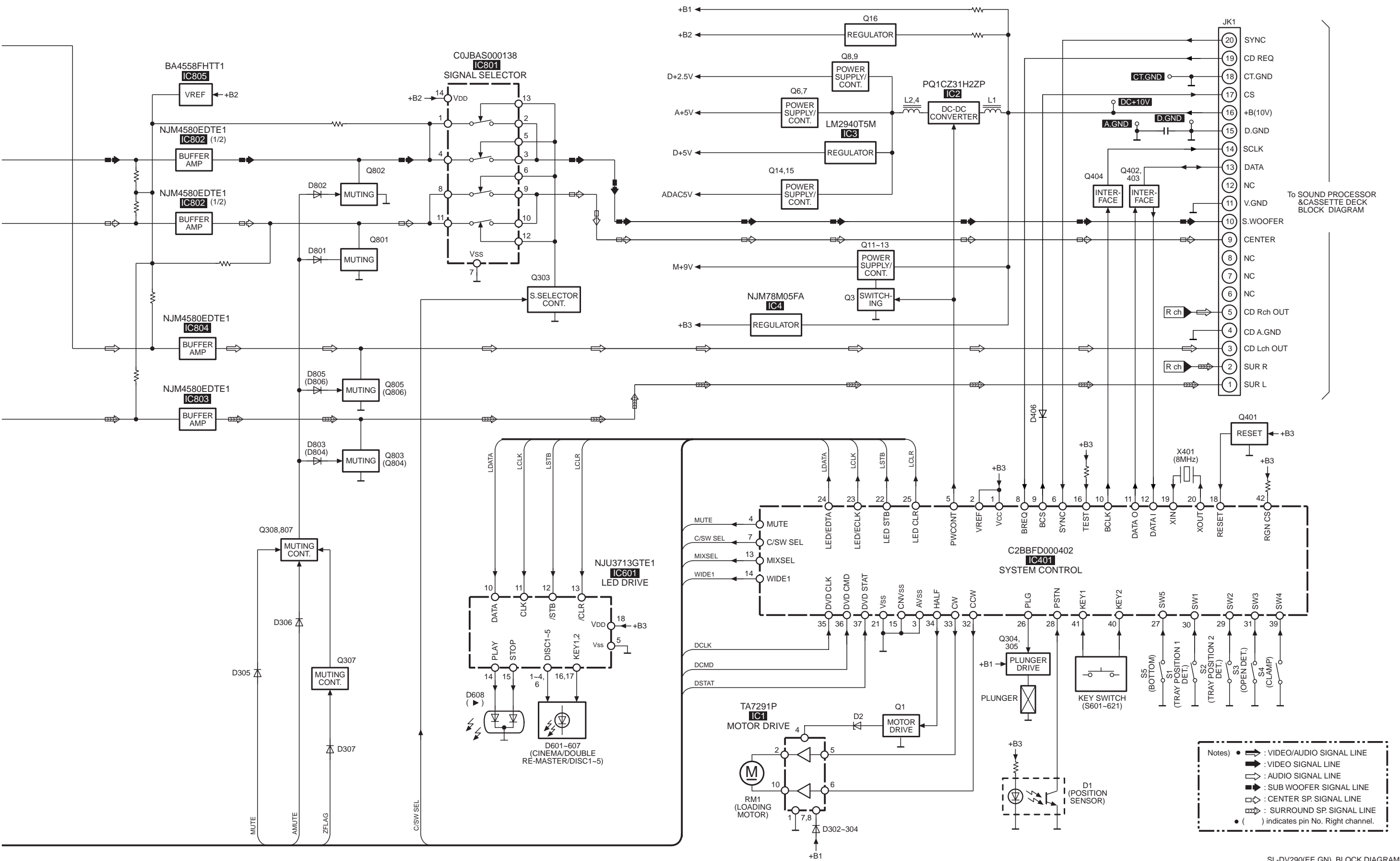

To SOUND PROCESSOR & CASSETTE DECK BLOCK DIAGRAM

- Notes:
- → : VIDEO/AUDIO SIGNAL LINE
 - ➡ : VIDEO SIGNAL LINE
 - ↳ : AUDIO SIGNAL LINE
 - ➡ : SUB WOOFER SIGNAL LINE
 - ◻ : CENTER SP. SIGNAL LINE
 - ➡ : SURROUND SP. SIGNAL LINE
 - () : indicates pin No. Right channel.

Note: This printed circuit board diagram may be modified at any time with the development of new technology.

A INTERFACE P.C.B. (SIDE : A)

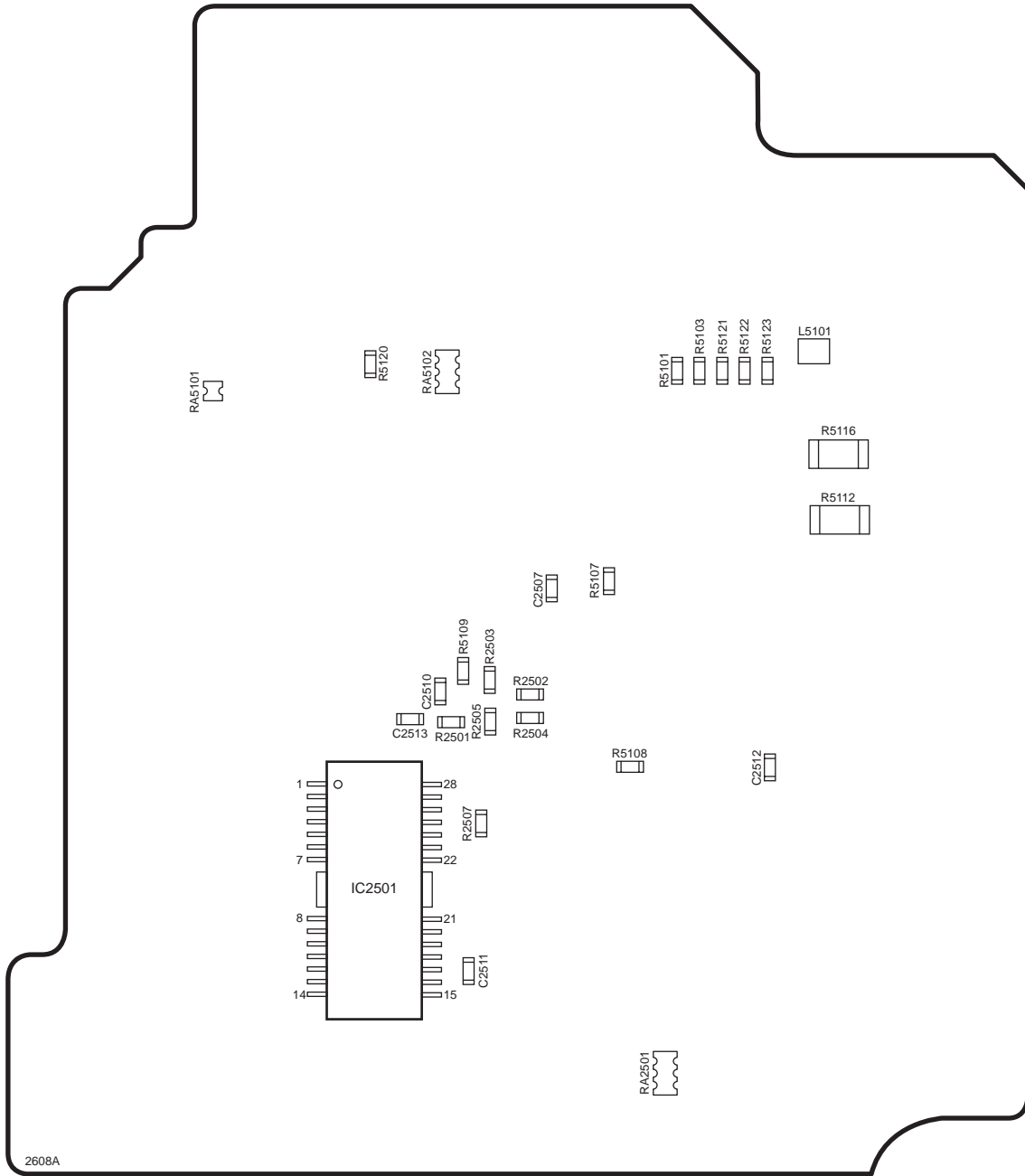

A INTERFACE P.C.B. (SIDE : B)

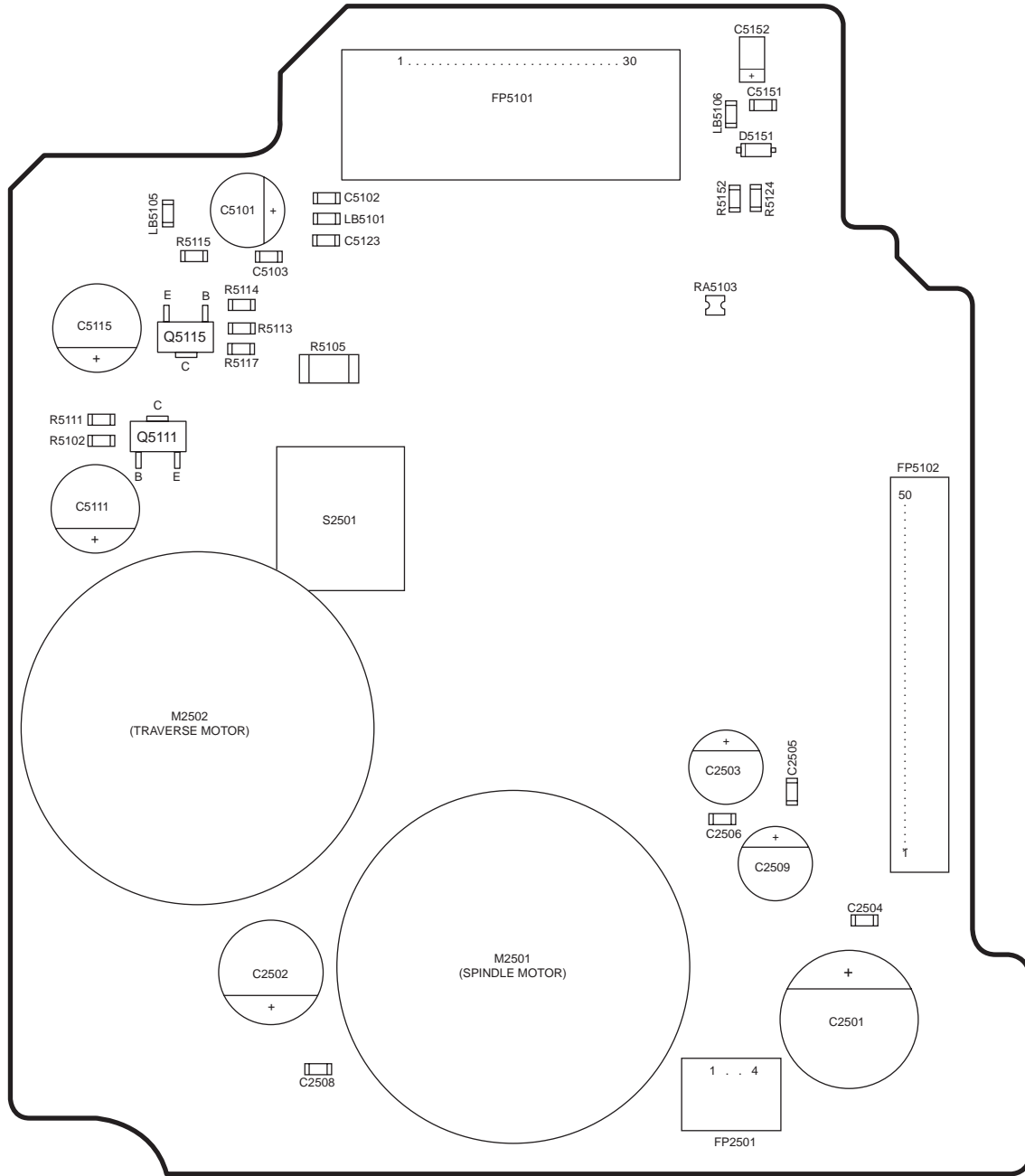

E LOADING MOTOR P.C.B.

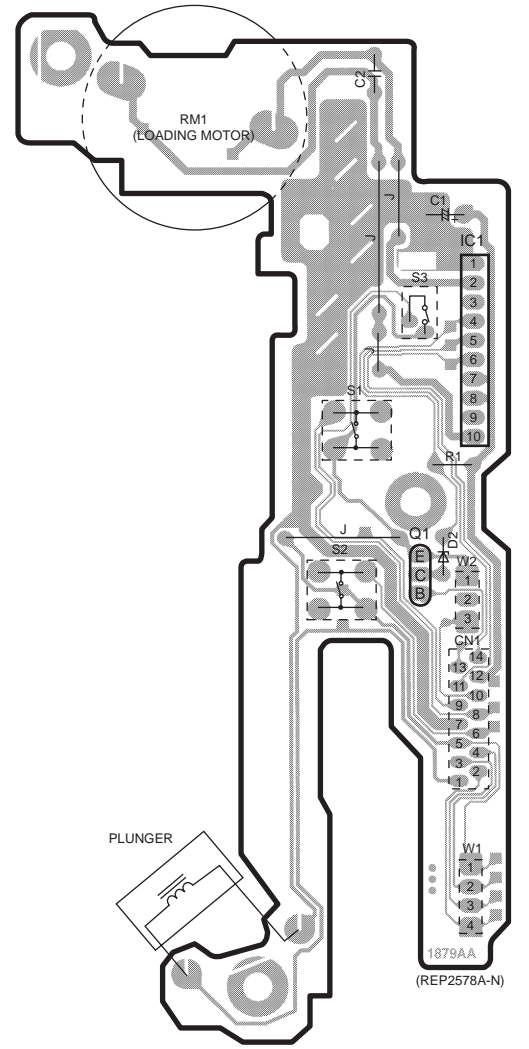

F CLAMP SW P.C.B.

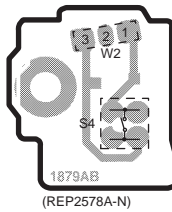

G BOTTOM SW P.C.B.

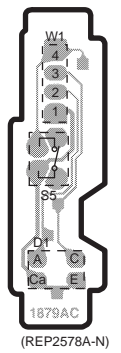

B DVD MODULE P.C.B. (SIDE : A)

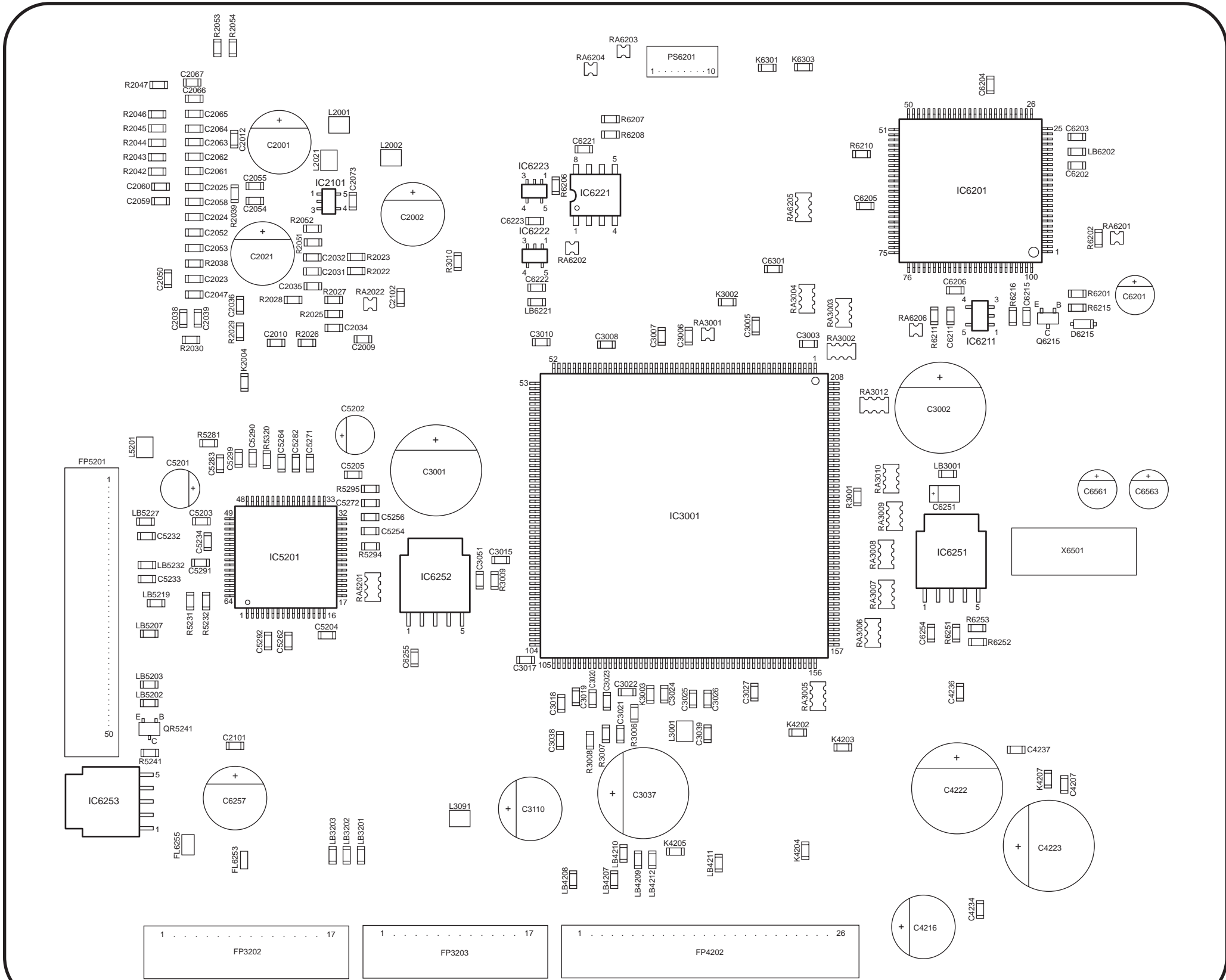

C MAIN P.C.B. (SIDE : A)

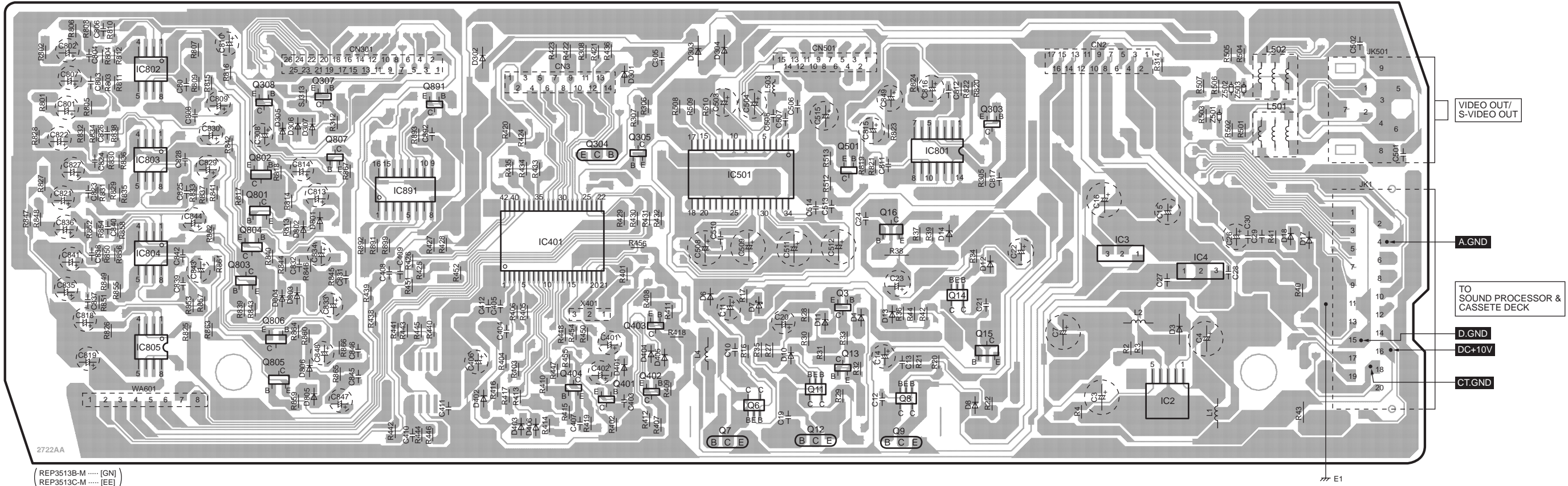

C MAIN P.C.B. (SIDE : B)

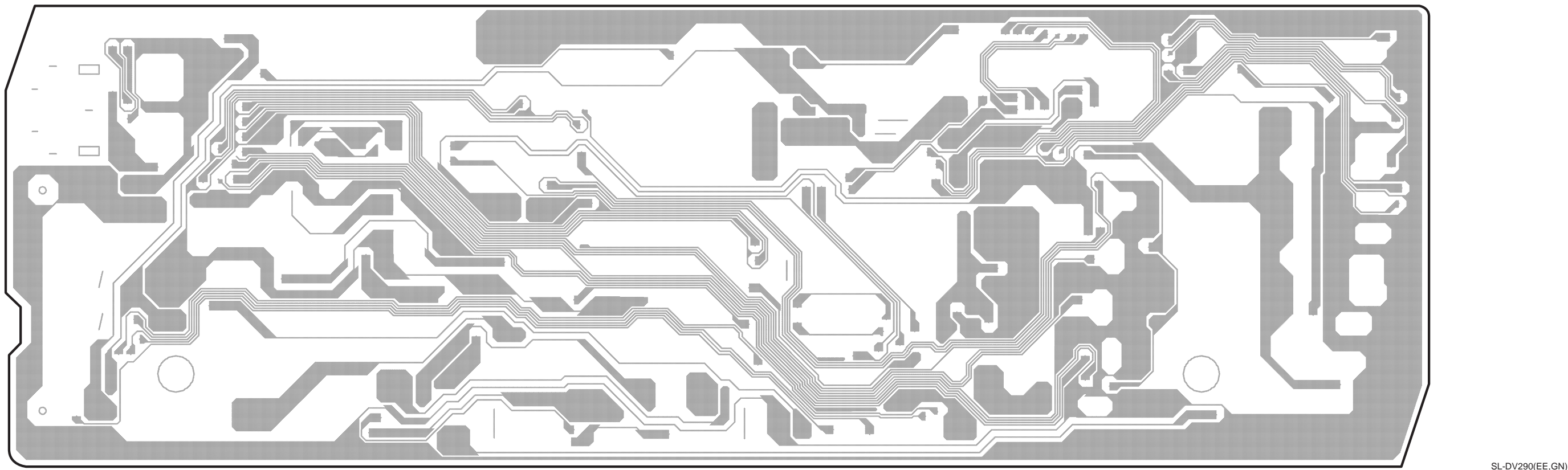

D OPERATION P.C.B. (SIDE : A)

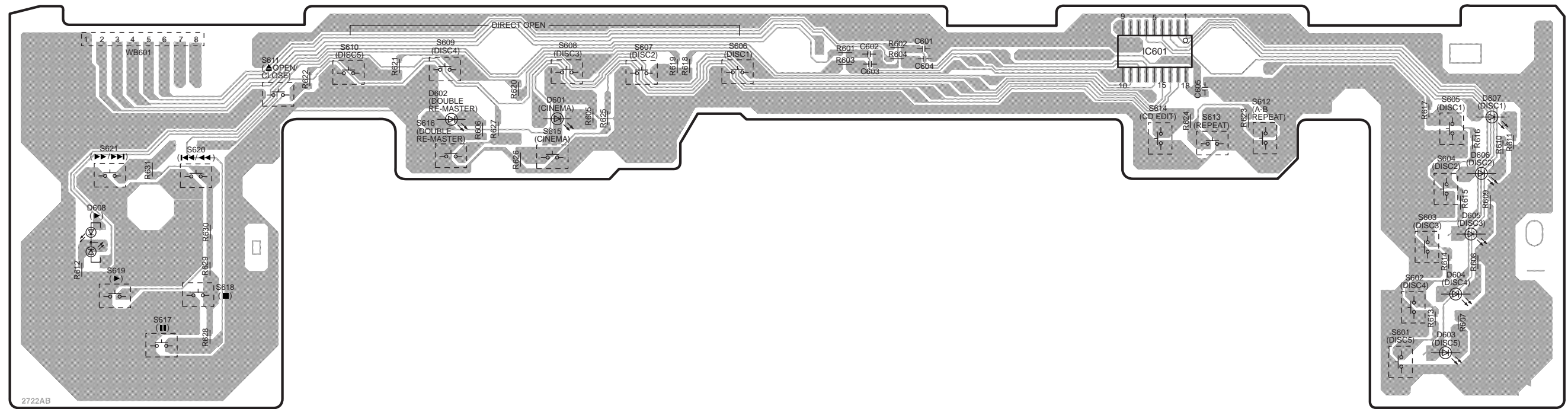

2722AB
 (REP3513B-M [GN])
 (REP3513C-M [EE])

D OPERATION P.C.B. (SIDE : B)

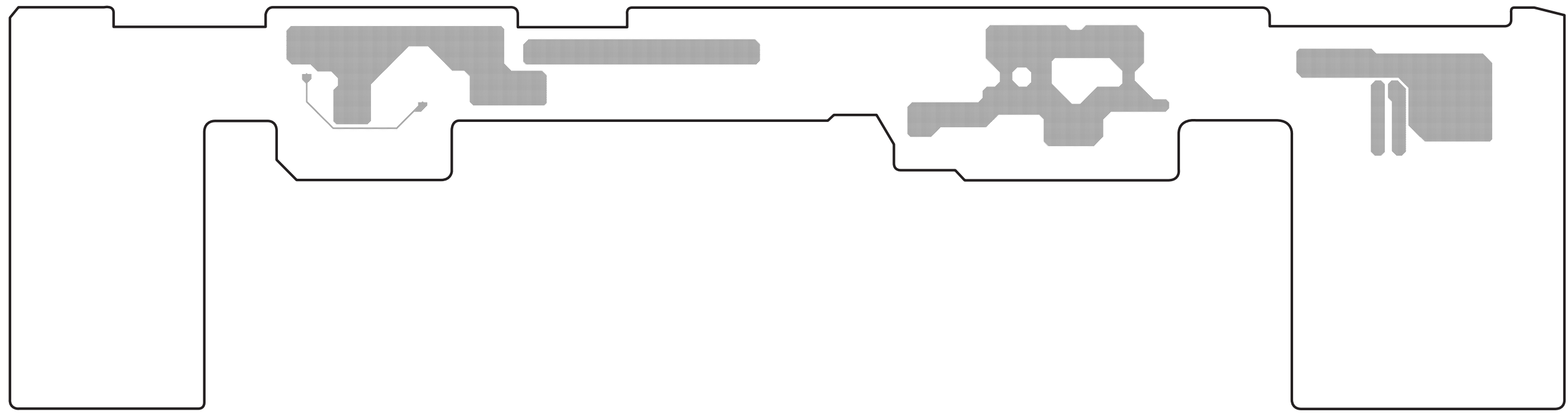

NOTE:
The number which noted at the connectors on the schematic diagram as "SCHEMATIC DIAGRAM-1" or "SCHEMATIC DIAGRAM-2" indicates the schematic diagram serial number located on the left corner in the schematic diagram.

→ : POSITIVE VOLTAGE LINE ⇨ : AUDIO/VIDEO SIGNAL LINE

A INTERFACE CIRCUIT

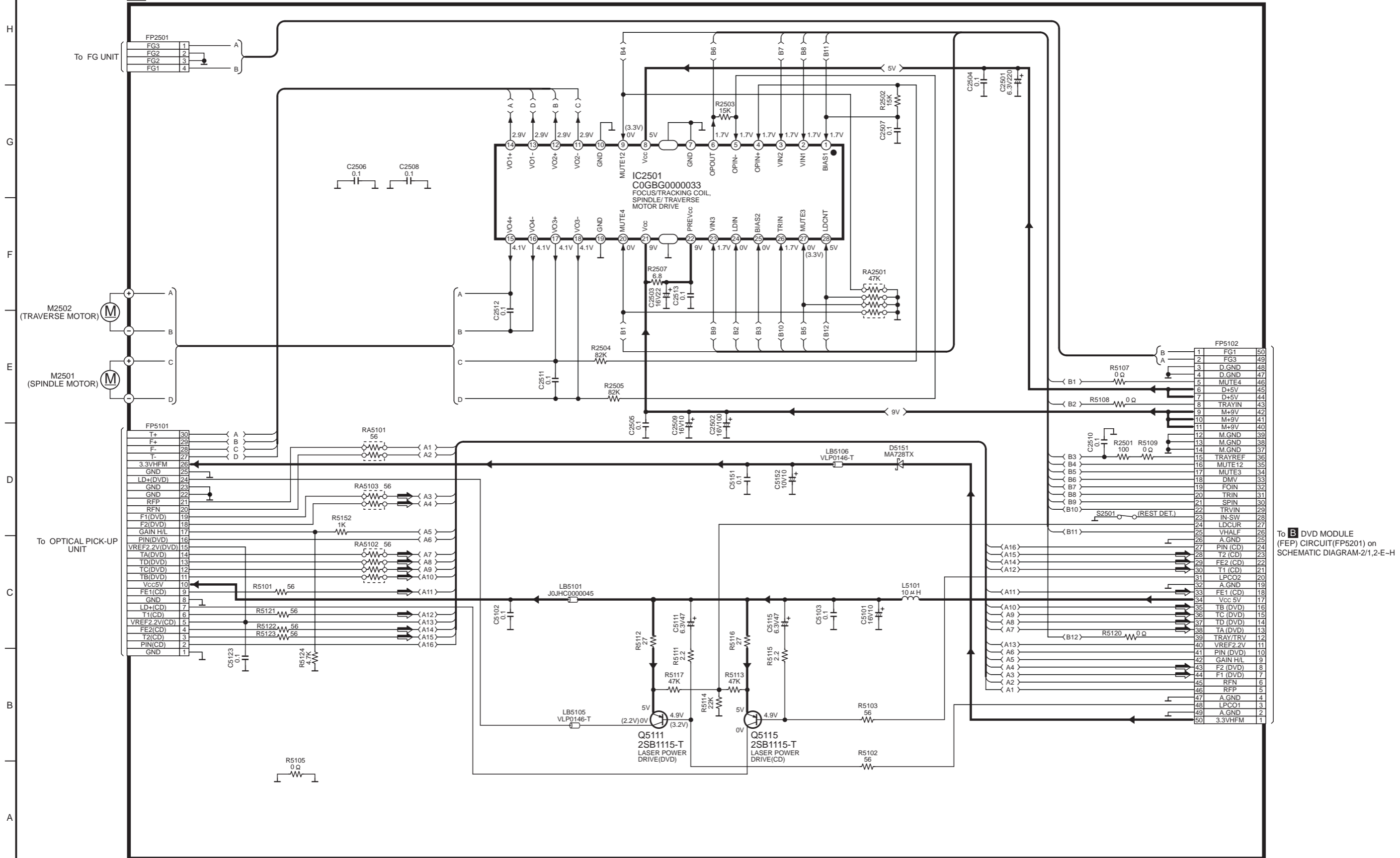

B DVD MODULE(FEP) CIRCUIT

→ : POSITIVE VOLTAGE LINE ⇨ : AUDIO/VIDEO SIGNAL LINE

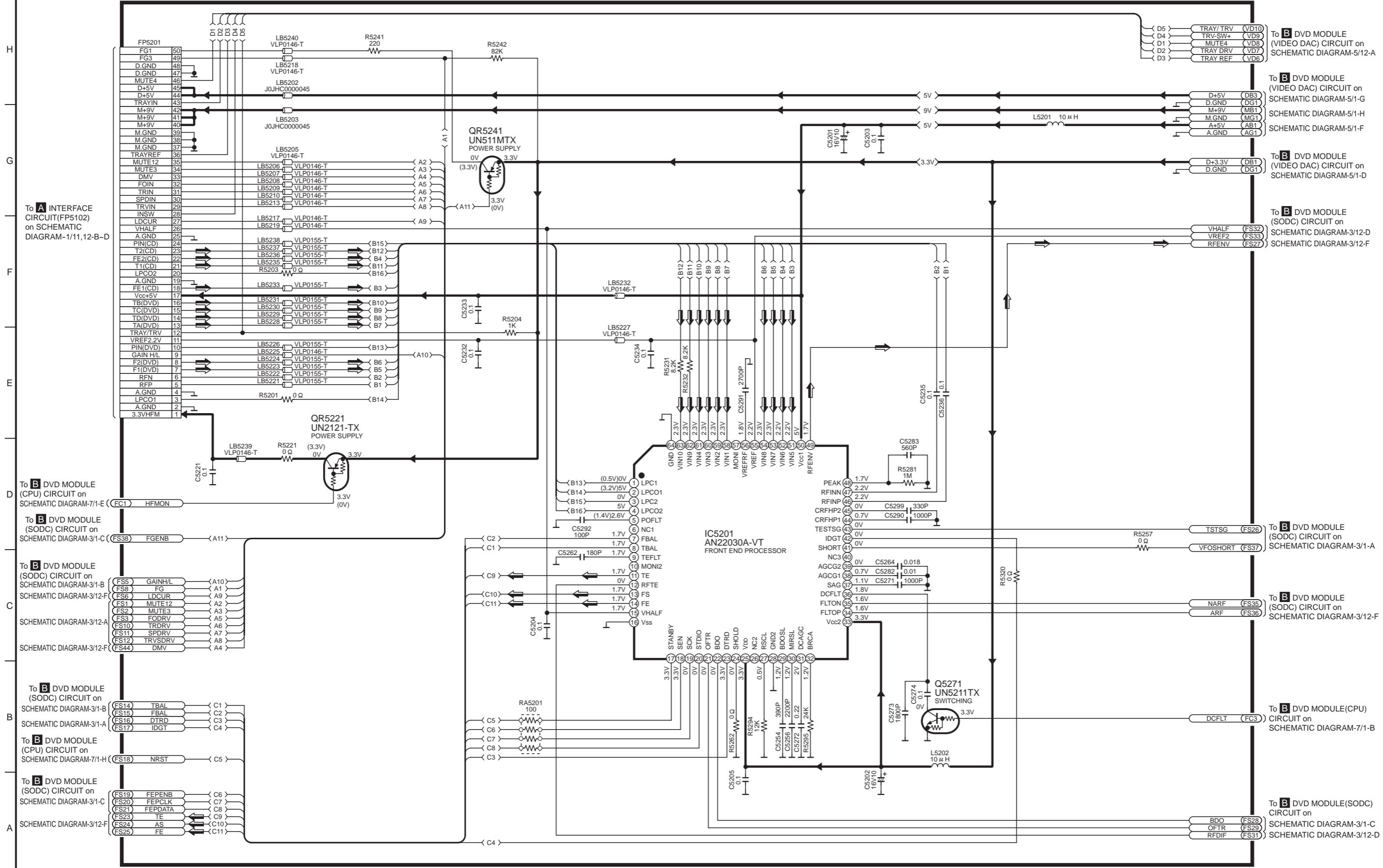

To **B** DVD MODULE (VIDEO DAC) CIRCUIT on SCHEMATIC DIAGRAM-5/12-A

To **B** DVD MODULE (VIDEO DAC) CIRCUIT on SCHEMATIC DIAGRAM-5/1-G
 To **B** DVD MODULE (VIDEO DAC) CIRCUIT on SCHEMATIC DIAGRAM-5/1-H
 To **B** DVD MODULE (VIDEO DAC) CIRCUIT on SCHEMATIC DIAGRAM-5/1-F

To **B** DVD MODULE (VIDEO DAC) CIRCUIT on SCHEMATIC DIAGRAM-5/1-D

To **B** DVD MODULE (SODC) CIRCUIT on SCHEMATIC DIAGRAM-3/12-D
 To **B** DVD MODULE (SODC) CIRCUIT on SCHEMATIC DIAGRAM-3/12-F

To **A** INTERFACE CIRCUIT(FP5102) on SCHEMATIC DIAGRAM-1/11,12-B-D

To **B** DVD MODULE (CPU) CIRCUIT on SCHEMATIC DIAGRAM-7/1-E (FC1) HFMON

To **B** DVD MODULE (SODC) CIRCUIT on SCHEMATIC DIAGRAM-3/1-C (FS38) FGENB

To **B** DVD MODULE (SODC) CIRCUIT on SCHEMATIC DIAGRAM-3/1-B
 To **B** DVD MODULE (SODC) CIRCUIT on SCHEMATIC DIAGRAM-3/12-F
 To **B** DVD MODULE (SODC) CIRCUIT on SCHEMATIC DIAGRAM-3/12-A
 To **B** DVD MODULE (SODC) CIRCUIT on SCHEMATIC DIAGRAM-3/12-F

To **B** DVD MODULE (SODC) CIRCUIT on SCHEMATIC DIAGRAM-3/1-B
 To **B** DVD MODULE (SODC) CIRCUIT on SCHEMATIC DIAGRAM-3/1-A

To **B** DVD MODULE (CPU) CIRCUIT on SCHEMATIC DIAGRAM-7/1-H (FS18) NRST

To **B** DVD MODULE (SODC) CIRCUIT on SCHEMATIC DIAGRAM-3/1-C

To **B** DVD MODULE (SODC) CIRCUIT on SCHEMATIC DIAGRAM-3/1-A

To **B** DVD MODULE (SODC) CIRCUIT on SCHEMATIC DIAGRAM-3/12-F

To **B** DVD MODULE (CPU) CIRCUIT on SCHEMATIC DIAGRAM-7/1-B

To **B** DVD MODULE (SODC) CIRCUIT on SCHEMATIC DIAGRAM-3/1-C
 To **B** DVD MODULE (SODC) CIRCUIT on SCHEMATIC DIAGRAM-3/12-D

