

Service Manual

Tuner/Amplifier

Tuner/Amplifier SA-EH500

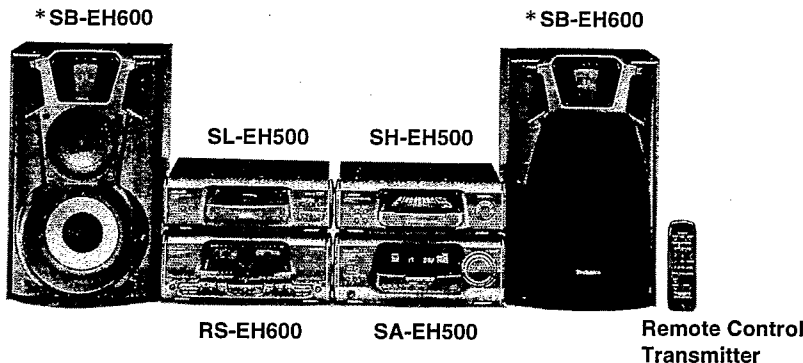

Because of unique interconnecting cables, when a component requires service, send or bring in the entire system.

Colour
(H) Gray Type

Areas
(E) Europe.
(EB) Great Britain.
(EG) Germany and Italy.
(EP) Russia.

System	SA-EH500
Sound Processor	SH-EH500
Tuner / Amplifier	SA-EH500
CD Player	SL-EH500
Cassette Deck	RS-EH600
Front Speakers*	SB-EH600

* : Made in PAES

Specifications

Amplifier Section

Power output :	
DIN 1 kHz, THD 1%, both channels driven ;	2 × 50 W(6 Ω)
RMS 1 kHz, THD 10%, both channels driven ;	2 × 75 W(6 Ω)
Total harmonic distortion :	
Rated power at 1 kHz ;	1 % (6 Ω)
Half power at 1 kHz ;	0.09 % (6 Ω)
Load impedance (HIGH/LOW) :	total impedance 6 Ω
Input sensitivity/impedance:	
EXTERNAL, AUX ;	250 mV/15 kΩ
Output level:	
EXTERNAL RECOUT ;	250 mV/1.5 kΩ
S.WOOFER :	
Center frequency ;	70 Hz
LEVEL (VOL -20 dB)	MID +8 dB MAX +12 dB

FM Tuner Section

Frequency range ;	87.50 – 108.00 MHz (0.05 MHz steps)
Sensitivity ;	1.8 μV (IHF usable)
S/N 26 dB ;	1.5 μV
S/N:	
MONO ;	70 dB (75 dB, IHF)
Antenna terminal(s) ;	75 Ω (unbalanced)

AM Tuner Section

Frequency range:	522 – 1611 kHz (9 kHz steps) 530 – 1620 kHz (10 kHz steps)
Sensitivity (S/N 20 dB) ;	500 μV/m

Timer Section

Clock :	Quartz-lock type
Function :	Play timer (1 time), Rec timer (1 time), Sleep (120 min, 30 min intervals)
Setting :	1 minute – 23 hours 59 minutes (1 min intervals)

General

Power supply :	
For (E), (EG), (EP) areas ;	AC 230V, 50 Hz
For (EB) area ;	AC 230–240 V, 50 Hz
Power consumption :	120 W
Dimensions :	287 (W) × 118.5 (H) × 343.5 (D) mm
Weight :	4.4 kg

Notes: Specifications are subject to change without notice.
Weight and dimensions are approximate.

⚠ WARNING

This service information is designed for experienced repair technicians only and is not designed for use by the general public. It does not contain warnings or cautions to advise non-technical individuals of potential dangers in attempting to service a product. Products powered by electricity should be serviced or repaired only by experienced professional technicians. Any attempt to service or repair the product or products dealt with in this service information by anyone else could result in serious injury or death.

Technics®

© 1998 Matsushita Electric Industrial Co., Ltd.
All rights reserved. Unauthorized copying
and distribution is a violation of law.

■ Contents

	Page		Page
Before Repair	2	To Check Operation	14
Protection Circuitry	2	About the Self-Diagnostic Mode	15
Accessories	2	Schematic Diagram	16 - 29
Caution for AC Main Lead	3	Printed Circuit Board Diagram	30 - 33
Location of Controls	4	Wiring Connection Diagram	34
Installation	4	Type Illustration of IC's, Transistors and Diodes	35
Connections	5 - 7	Terminal Function of IC's	36
Enjoying RDS Broadcasts	8, 9	Block Diagram	37 - 41
Setting the Time	9	Replacement Parts List	42 - 46
Operation Checks and Main Component Replacement Procedures	10 - 13	Cabinet Parts Location	47
To Supply Power Source	14	Packaging	48

■ Before Repair

- (1) Turn off the power supply. Using a 10 Ω, 10 W resistor, connect both ends of power supply capacitors (C701, C702, C703 and C704) in order to discharge the voltage.
- (2) Before turning the power supply on, after completion of repair, slowly apply the primary voltage by using a power supply voltage controller to make sure that the consumed current at 50 Hz in NO SIGNAL mode should be shown below with respect to supply voltage 230 V or 240 V.

Power supply voltage	AC 230 V	AC 240 V
Consumed current 50 Hz	70 ~ 250 mA	70 ~ 250 mA

■ Protection Circuitry

The protection circuitry may have operated if either of the following conditions is noticed:

- * No sound is heard when the power is switched ON.
- * Sound stops during a performance.





The functions of this circuitry is to prevent circuitry damage if, for example, the positive and negative speaker connection wires are "shorted", or if speaker systems with an impedance less than the indicated rated impedance of this unit are used.

If this occurs, follow the procedure outlined below:

1. Switch OFF the power.
2. Determine the cause of the problem and correct it.
3. Switch ON the power once again.

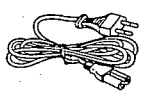
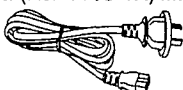
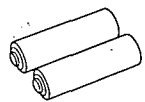
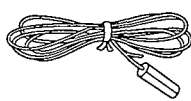
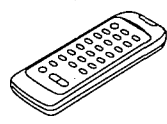
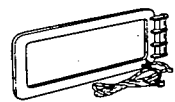
Note:
When the protection circuitry functions, the unit will not operate unless the power is first switched OFF and then ON again.

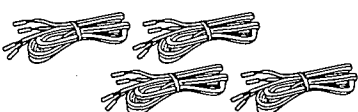
■ Accessories

- **AC power supply cord**
For (E), (EG), (EP) areas (RJA0019-X) ... 1 pc.  For (EB) area (RJA0053-1X) 1 pc. 
- **Batteries**
(UM-4, "AAA", R03) 2 pcs. 
Note: These are available on sales route.
- **FM indoor antenna**
(RSA0007) 1 pc. 
- **Remote control transmitter**
(RAK-CH426WH) 1 pc. 
- **AM loop antenna**
(RSA0022-J) 1 pc.  
- **Speaker cords**
(REE0499) 2 pcs. 
(REE0853) 2 pcs.
- **Antenna plug adaptor**
For (EB) only (SJP9009) 1 pc. 

■ Caution for AC Main Lead



("EB" area code model only)

For your safety, please read the following text carefully.

This appliance is supplied with a moulded three pin mains plug for your safety and convenience.

A 5-ampere fuse is fitted in this plug.

Should the fuse need to be replaced please ensure that the replacement fuse has a rating of 5-ampere and that it is approved by ASTA or BSI to BS1362.

Check for the ASTA mark  or the BSI mark  on the body of the fuse.

If the plug contains a removable fuse cover you must ensure that it is refitted when the fuse is replaced.

If you lose the fuse cover the plug must not be used until a replacement cover is obtained.

A replacement fuse cover can be purchased from your local dealer.

CAUTION!

IF THE FITTED MOULDED PLUG IS UNSUITABLE FOR THE SOCKET OUTLET IN YOUR HOME THEN THE FUSE SHOULD BE REMOVED AND THE PLUG CUT OFF AND DISPOSED OF SAFELY.

THERE IS A DANGER OF SEVERE ELECTRICAL SHOCK IF THE CUT OFF PLUG IS INSERTED INTO ANY 13-AMPERE SOCKET.

If a new plug is to be fitted please observe the wiring code as shown below.

If in any doubt please consult a qualified electrician.

IMPORTANT

The wires in this mains lead are coloured in accordance with the following code:

Blue: Neutral, Brown: Live.

As these colours may not correspond with the coloured markings identifying the terminals in your plug, proceed as follows:

The wire which is coloured Blue must be connected to the terminal which is marked with the letter N or coloured Black or Blue.

The wire which is coloured Brown must be connected to the terminal which is marked with the letter L or coloured Brown or Red.

WARNING: DO NOT CONNECT EITHER WIRE TO THE EARTH TERMINAL WHICH IS MARKED WITH THE LETTER E, BY THE EARTH SYMBOL \perp OR COLOURED GREEN OR GREEN/YELLOW.

THIS PLUG IS NOT WATERPROOF—KEEP DRY.

Before use

Remove the connector cover.

How to replace the fuse

The location of the fuse differ according to the type of AC mains plug (figures A and B). Confirm the AC mains plug fitted and follow the instructions below.

Illustrations may differ from actual AC mains plug.

1. Open the fuse cover with a screwdriver.

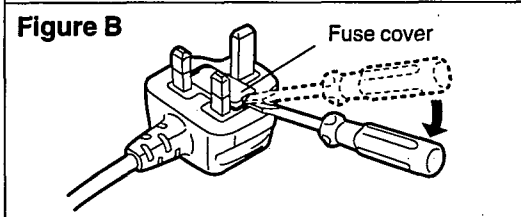
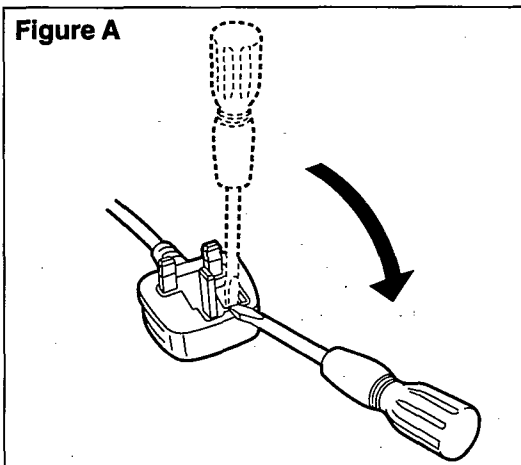

2. Replace the fuse and close or attach the fuse cover.

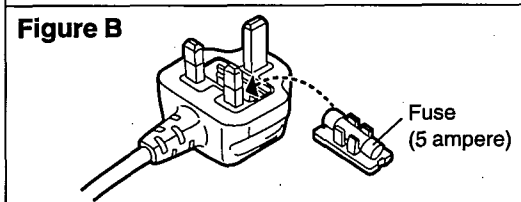
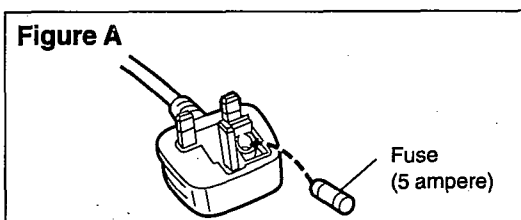

■ Location of Controls

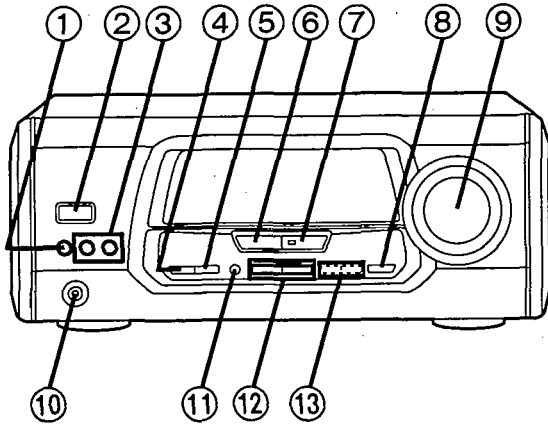

- ① Clock/timer button (CLOCK/TIMER)
- ② Power "STANDBY ⏻/ON" switch (POWER, STANDBY ⏻/ON)
- ③ Timer on/off buttons (⏻ PLAY, ⏻ REC)
- ④ Tuning mode select button (TUNING MODE)
- ⑤ Set button (SET)
- ⑥ Source input select button (INPUT SELECTOR)
- ⑦ Tuner/band select button and indicator (TUNER/BAND)
- ⑧ Super woofer button (S. WOOFER)
- ⑨ Volume control (VOLUME)
- ⑩ Headphones jack (PHONES)
- ⑪ FM mode select button (FM AUTO/MONO)
- ⑫ Tuning buttons (TUNING, V, Δ)

For (EG) and (EP) areas

- ⑬ RDS display mode select buttons (RDS PS-DISP MODE-PTY)

■ Installation

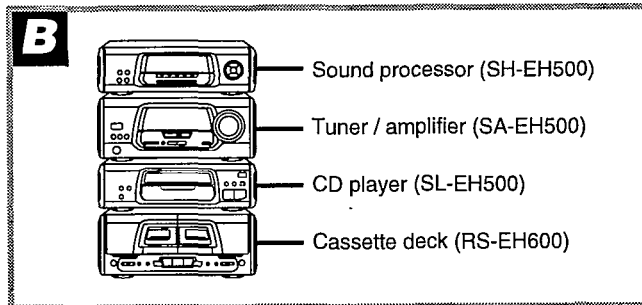
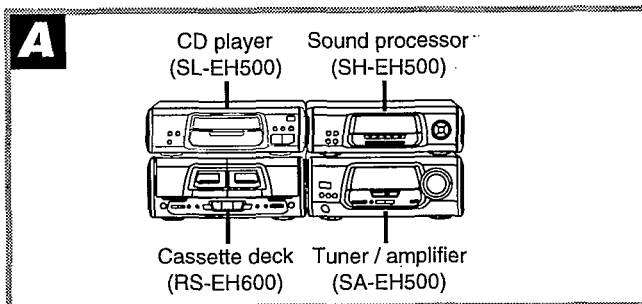

Locating the components

Side-by-side set-up **A**

Stacking **B**

Connections

Connect the AC power supply cord after you have connected all other cables.

To prepare the AM loop antenna wire, FM indoor antenna and speaker cords, twist the vinyl cover tip and pull off.

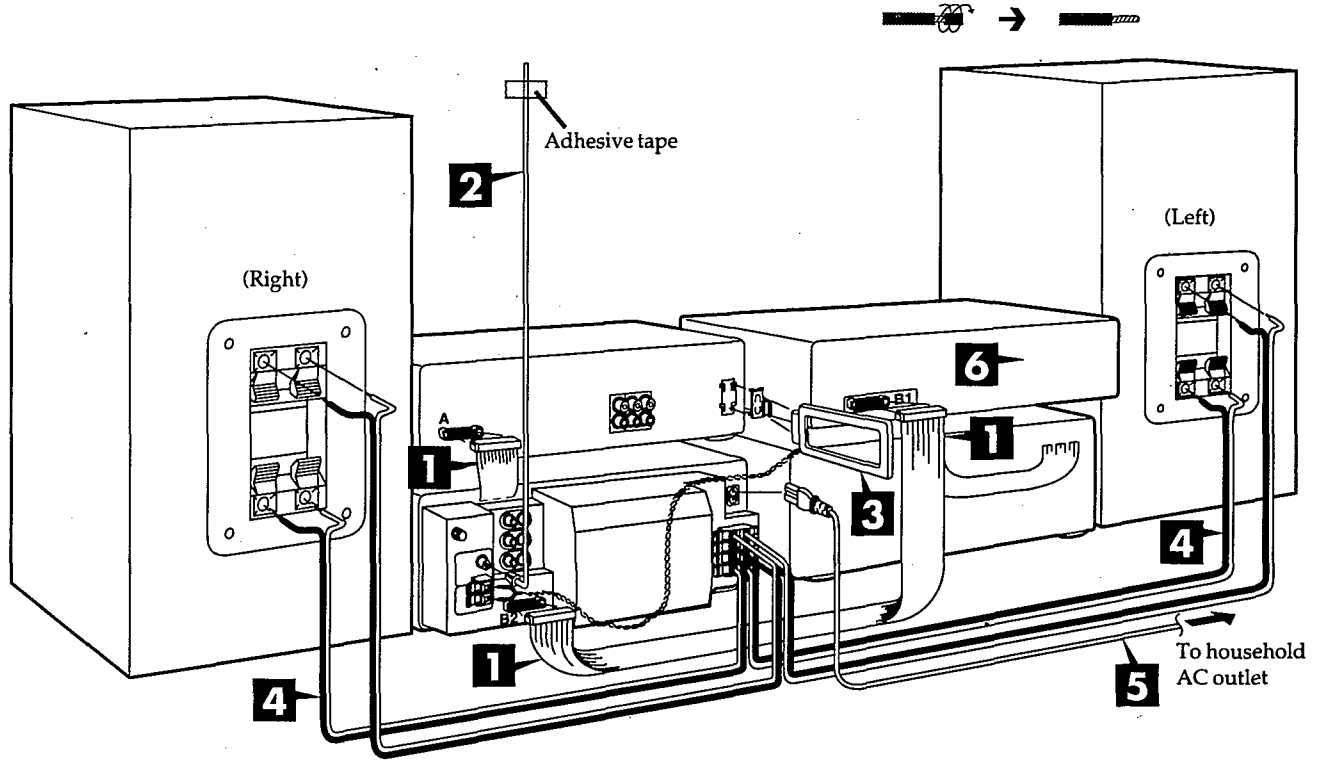

<p>1</p> <p>To connect cables To unplug cables</p> <p>Connector</p> <p>White line</p>	<p>3</p>	<p>5 (Insertion of Connector)</p> <p>Appliance inlet</p> <p>Connector</p> <p>Approx. 6 mm</p>
<p>2</p> <p>FM ANT 75Ω</p>	<p>4 Tuner/amplifier side</p> <p>Gray (+) Blue (-) Black (-)</p> <p>Red (+)</p> <p>Speaker side</p> <p>Blue (-)</p> <p>Gray (+) Black (-) Red (+)</p>	

1 Connect the flat cables.

1. Connect the shorter flat cable from the tuner/amplifier to terminal A on the sound processor.
2. Connect the longer flat cable from the cassette deck to terminals B1 and B2.

Note

Do not try connecting or disconnecting the flat cables while the power is switched to ON.

After connection:

Keep cables as flat against the back of the unit as possible.

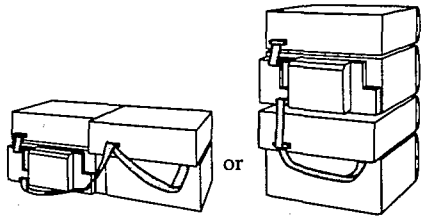
**2 Connect the FM indoor antenna.**

Tape the antenna to a wall or column, in a position where radio signals are received with the least amount of interference.

Note

When you cannot get good reception with this FM indoor antenna, we recommend you install an FM outdoor antenna (not included).

3 Connect the AM loop antenna.

1. Attach the antenna holder to the rear panel of the sound processor.
Then clamp the antenna into the antenna holder.
2. Connect the antenna terminal to the rear panel of the tuner/amplifier.

Note

To minimize noise pickup, bundle the loop antenna cord using tape or the like to keep the flat cables away from the AM loop antenna cord.

4 Connect the right (R) and left (L) front speaker cables.

Connect each end of the speaker cables to the terminal lever of the same color.

Note

- To prevent damage to circuitry, never short-circuit positive (+) and negative (-) speaker wires.
- Be sure to connect only positive (red or gray) wires to positive (+) terminals and negative (black or blue) wires to negative (-) terminals.
- Left and right front speakers are exactly the same.

5 Connect the AC mains lead.

(United Kingdom only)

BE SURE TO READ THE CAUTION FOR AC MAINS LEAD ON PAGE 3 BEFORE PROCEEDING TO STEP 5.

Insertion of Connector

Even when the connector is perfectly inserted, depending on the type of inlet used, the front part of the connector may jut out as shown in the drawing.

However there is no problem using the unit.

Speaker Caution

Use the speakers only with the recommended system. Failure to do so may lead to damage to the amplifier and/or the speaker, and may result in the risk of fire. Consult a qualified service person if damage has occurred or if you experience a sudden change in performance.

When speakers are connected to the LOW and HIGH terminals on the back of the main unit

They are designed to have a combined impedance of 6Ω.

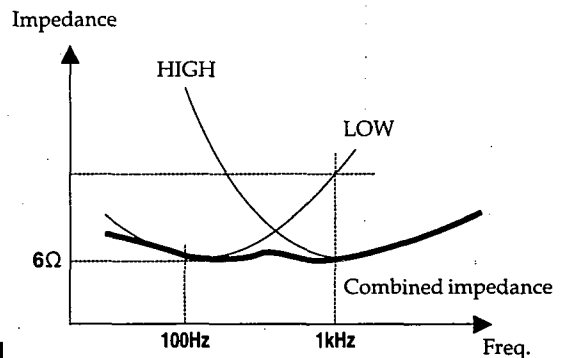
**Note**

Never use speakers other than those supplied. (SB-EH600) For instance, if you connect speakers with an impedance of 6Ω each and plug them into the LOW and HIGH terminals, you will only have a combined impedance of 3Ω

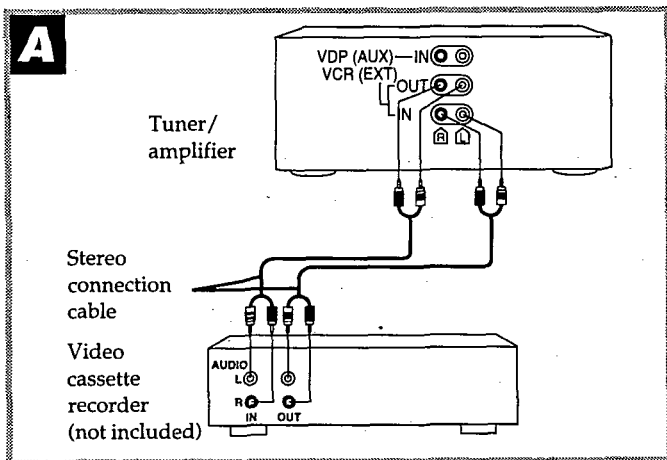

External unit connections

- Make sure that the power supply for all components has been turned off before making any connections.
- For details, refer to the operating instructions of the units which are to be connected.
- All peripheral components and cables sold separately.

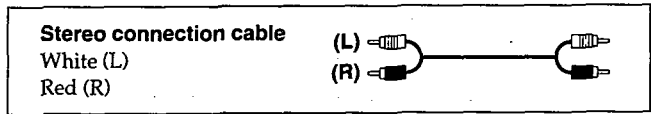

A Video Cassette recorder

B Laser disc player

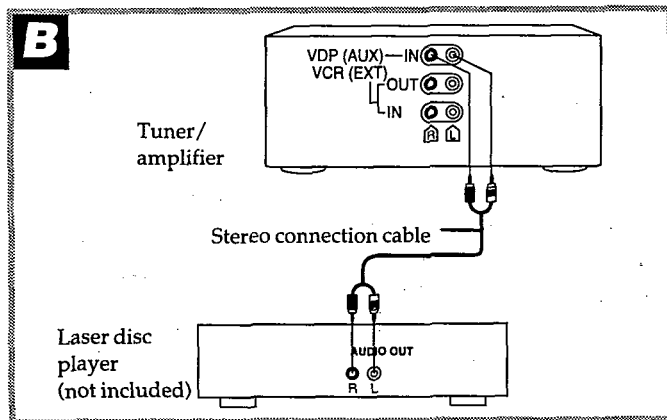

Optional antenna connections

You may need an outdoor antenna if you use this system in a mountainous region or inside a reinforced-concrete building, etc.

FM outdoor antenna (not included) C

Note

An outdoor antenna should be installed by a qualified technician only.

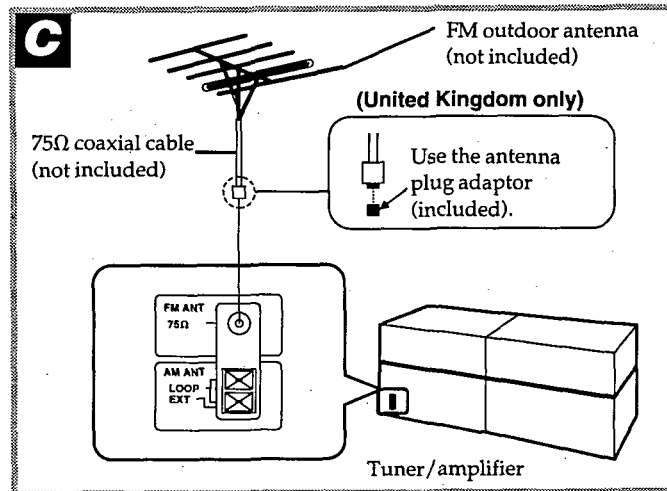

AM outdoor antenna (not included) D

Connect the outdoor antenna without removing the AM loop antenna. Run 5 to 12 m of vinyl-covered wire horizontally along a window or other convenient location.

Note

When the unit is not in use, disconnect the outdoor antenna to prevent possible damage that may be caused by lightning. Never use an outdoor antenna during an electrical storm.

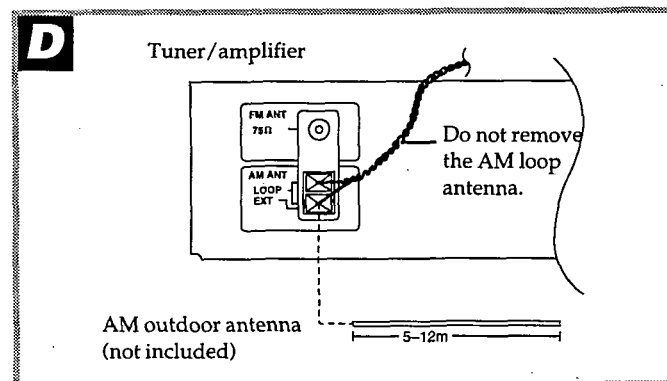

■ Enjoying RDS Broadcasts [For (EG) and (EP) areas]

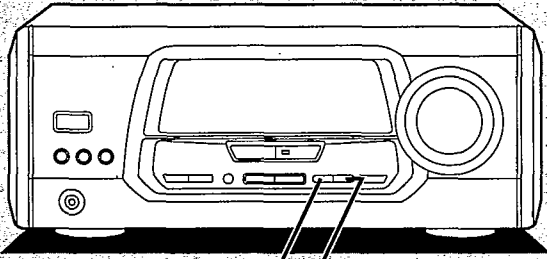
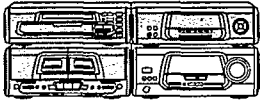

RDS
PS - DISP MODE - PTY

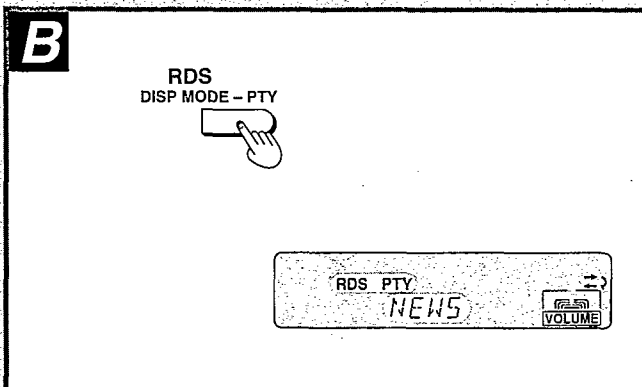
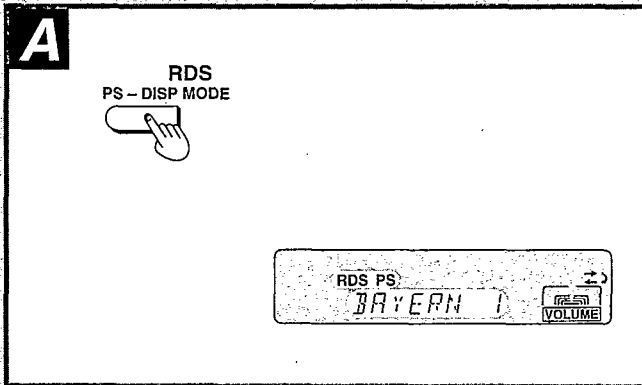

This unit lets you take advantage of the Radio Data System (RDS) in areas where RDS broadcast services are received. This advanced system provides useful information, utilizing a 57 kHz subcarrier above the audible range, in addition to the main FM signal.

Types of RDS and functions

To display the name of a broadcast station (PS display):

When this system receives a PS signal in an RDS broadcast, the name of the broadcast station is shown on the display.

To display the type of a program (PTY display):

While the PTY signal is being received, the name of the type of program currently being broadcast can be shown on the display.

Notes

- Even if an FM broadcast station is transmitting RDS signals, the functions of this system may not be able to utilize these signals if the signal quality is too poor.
- "PTY" may not be available in some areas. (Future function)

To display the name of a broadcasting station ^A

(When the FM station is received)

Press PS-DISP MODE.

If the FM broadcast being received provides the RDS service ("RDS" indicator will light), the name of the broadcast station and "PS" indicator will be shown on the display of this system.

Each time you press the button, frequency display and PS display will appear alternately.

To display the type of a program ^B

(When the FM station is received)

Press DISP MODE-PTY.

If the FM broadcast being received provides the RDS service ("RDS" indicator will light), the type of the program and "PTY" indicator will be shown on the display of this system.

Each time you press the button, frequency display and PTY display will appear alternately.

Note

When receiving a broadcast station, in PTY mode, which does not transmit PTY, the display will not show "NO PTY" automatically.

About the PTY display

There are a total of 15 PTY displays on this unit. The table gives an explanation of each display.

Display	Explanation
NEWS	Short accounts of facts, events and publicly expressed views, reportage and actuality.
AFFAIRS	Topical program expanding or enlarging upon the news, generally in different presentation style or concept, including documentary debate, or analysis.
INFO	Program whose purpose is to impart advice in the widest sense, including meteorological reports and forecasts, consumer affairs, medical help, etc.
SPORT	Program concerned with any aspect of sport.
EDUCATE	Program intended primarily to educate.
DRAMA	All radio plays and serials.
CULTURE	Programs concerned with any aspect of national or regional culture, including religious affairs, philosophy, social science, language, theatre, etc.
SCIENCE	Programs about the natural sciences and technology.
VARIED	Used for mainly speech-based programs, usually of a light-entertainment nature not covered by above categories. Examples are: quizzes, panel games, personality interviews, comedy and satire.
POP M	Commercial music which would generally be considered to be of current popular appeal, often featuring in current or recent record sales charts.
ROCK M	Contemporary modern music, usually written and performed by young musicians.
M.O.R.M	(Middle of the Road Music). Common term to describe music considered to be "easy-listening", as opposed to Pop, Rock or Classical. Music in this category is often, but not always, vocal, and usually of short duration (<5 min.).
LIGHT M	Classical Musical for general, rather than specialist, appreciation. Examples of music in this category are instrumental music and vocal or choral works.
CLASSICS	Performances of major orchestral works, symphonies, chamber music etc., and including Grand Opera.
OTHER M	Musical styles not fitting into any of the above categories. Particularly used for specialist music, of which Jazz, Rhythm & Blues, Folk, Country, and Reggae are examples.

Setting the time

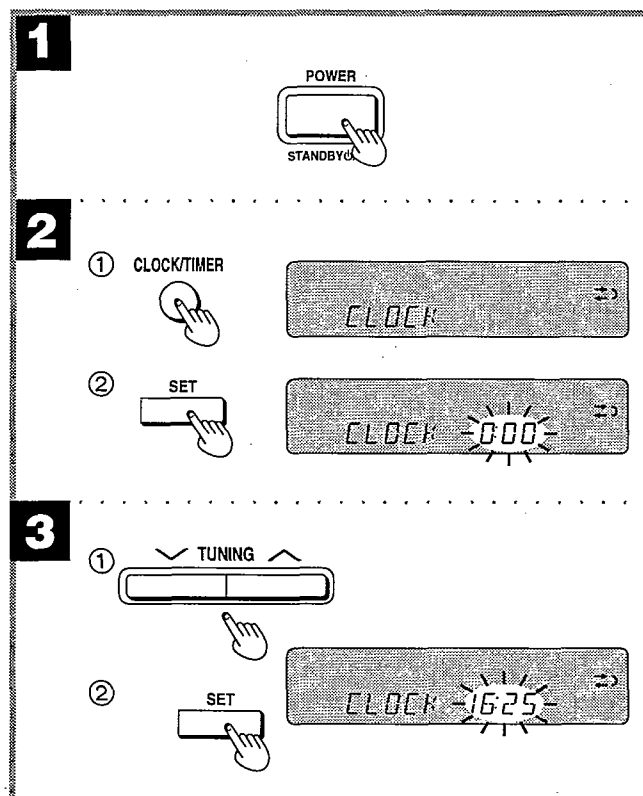
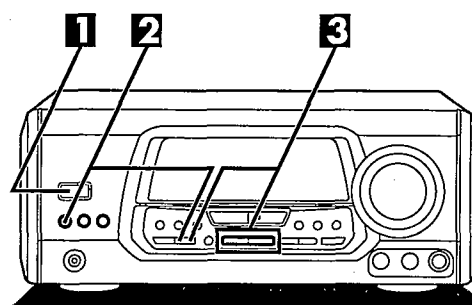

The tuner/amplifier displays the time, frequency and other information on CDs and tapes.

This is a 24-hour display clock.

The figure shows how to set the time for 16:25.

1 Switch on the power.

2 ① Press CLOCK/TIMER to show "CLOCK".

Every time you press the button, the indication changes in the order of CLOCK→⊕ PLAY→⊕ REC→Original display.

Within 5 seconds:

② Press SET.

3 ① Press TUNING (∨ or ∧) to set the present time on the display.

The time display can be changed in one minute units by tapping the buttons, and quickly by holding down the buttons.

② Press SET.

The display will return to the previous display after about 3 seconds.

■ Operation Checks and Main Component Replacement Procedures

NOTE

1. This section describes procedures for checking the operation of the major printed circuit boards and replacing the main components.
2. For reassembly after operation checks or replacement, reverse the respective procedures. Special reassembly procedures are described only when required.
3. Select items from the following index when checks or replacement are required.
4. Refer the parts No. on the page of "Main Component Replacement Procedures", if necessary.

● Contents

■ Checking Procedure for each P.C.B.

	Page.
1. Checking for the tuner P.C.B., BTL P.C.B. and power supply P.C.B.....	10.
2. Checking for the operation P.C.B.,.....	11.
3. Checking for the main P.C.B.,.....	11,12.

■ Main Component Replacement Procedures

1. Replacement for the power IC and regulator transistor.....	13.
---	-----

■ Checking Procedure for each P.C.B.

1. Checking for the tuner P.C.B., BTL P.C.B. and power supply P.C.B.

◦ Check the tuner P.C.B., BTL P.C.B. and power supply P.C.B. as shown below.

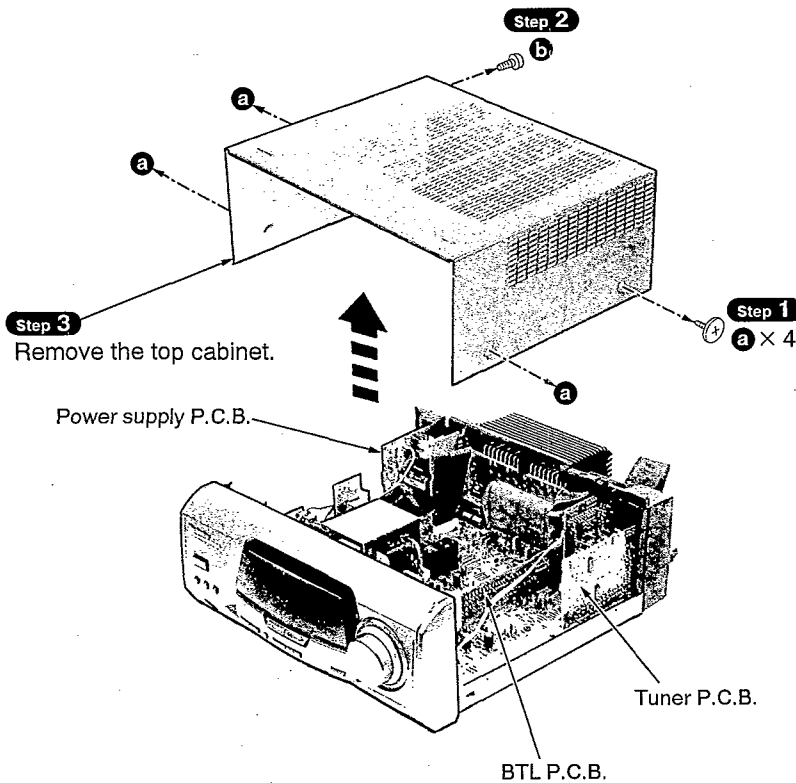

2. Checking for the operation P.C.B.

• Follow the **Step 1** ~ **Step 3** of the item 1 in checking procedure for each P.C.B. on page 10.

• Check the operation P.C.B. as shown below.

Step 2

pull out the front panel ass'y.

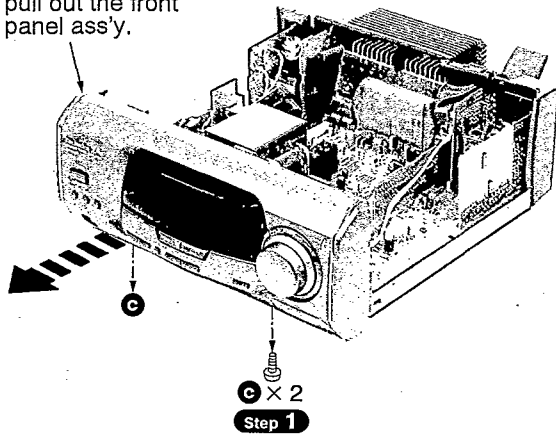

Operation P.C.B.

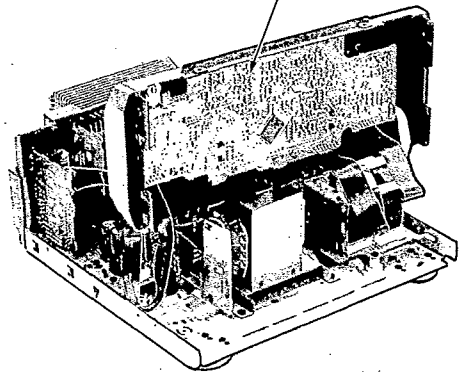

3. Checking for the main P.C.B.

• Follow the **Step 1** ~ **Step 3** of the item 1 in checking procedure for each P.C.B. on page 10.

Step 1

Remove the cable holder.

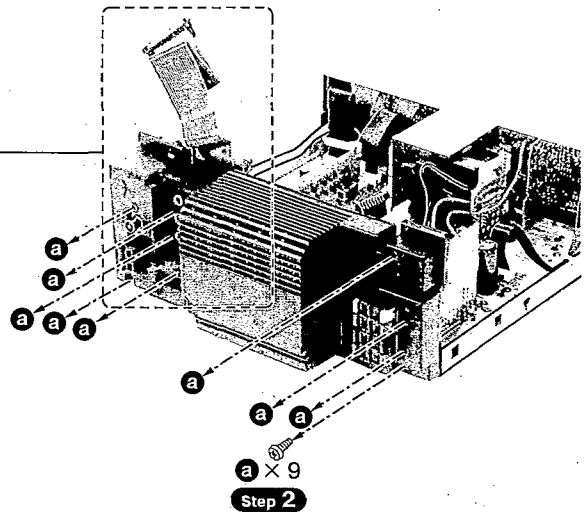
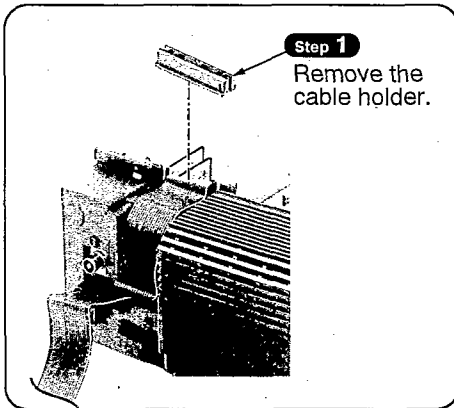

Rear grille ass'y

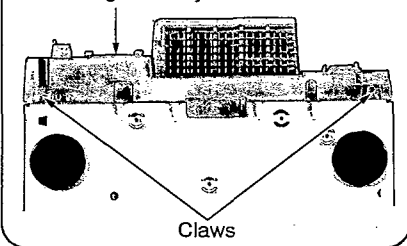

(Bottom)

Step 3

Release the 3 claws, and then remove the rear grille ass'y.

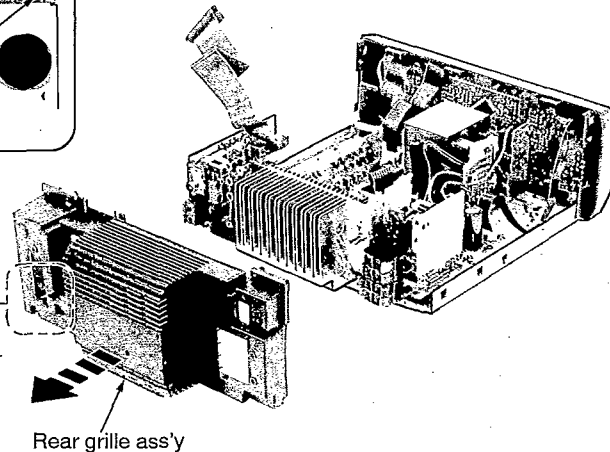
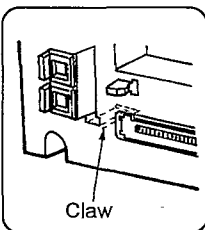

Notice for installation of rear grille ass'y

Align the partition of rear grille ass'y with the marking (▲) on the heat sink.

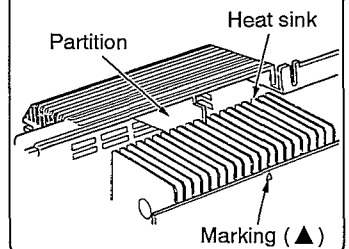

Step 7

Lift up the main P.C.B., and then release the rib of bottom chassis to remove the main P.C.B..

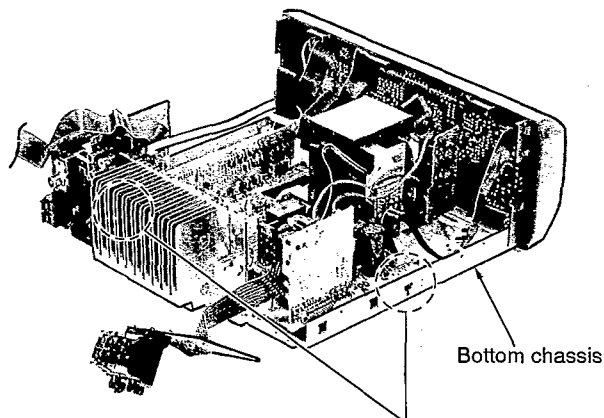
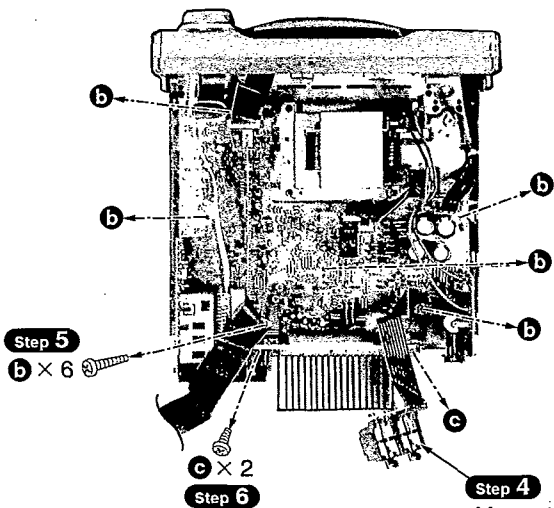

Step 4
Move the speaker terminal P.C.B. out of the unit.

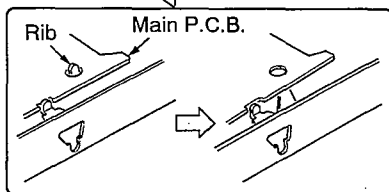

Step 8

Slide the main P.C.B. in the direction of arrow, and then release the hook of bottom chassis.

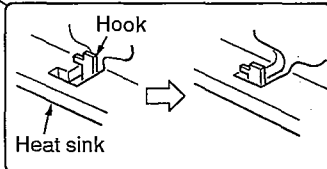
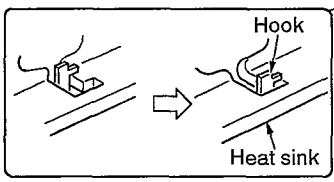
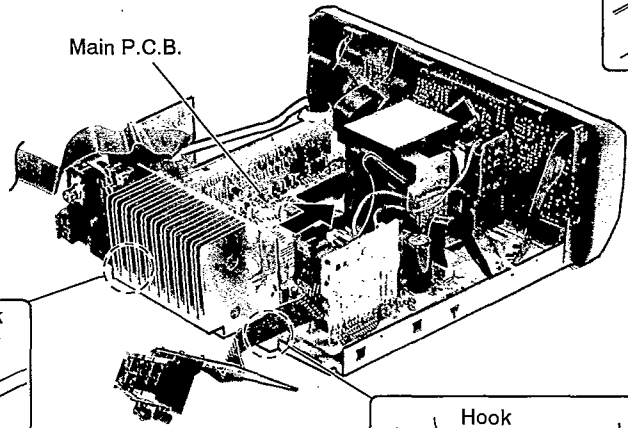

• Check the main P.C.B. as shown below.

Step 9

Connect the lead wire.

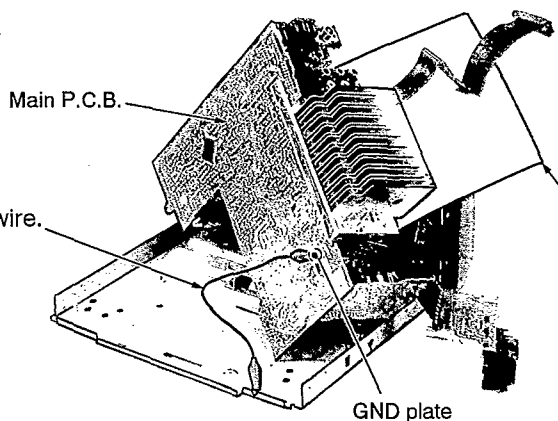

NOTE

Insulate main P.C.B. with insulation material to avoid short-circuit.

Main Component Replacement procedures

1. Replacement for the power IC and regulator transistor

- Follow the **Step 1** ~ **Step 3** of the item 1 in checking procedure for each P.C.B. on page 10.
- Follow the **Step 1** ~ **Step 8** of the item 3 in checking procedure for each P.C.B. on pages 11 and 12.

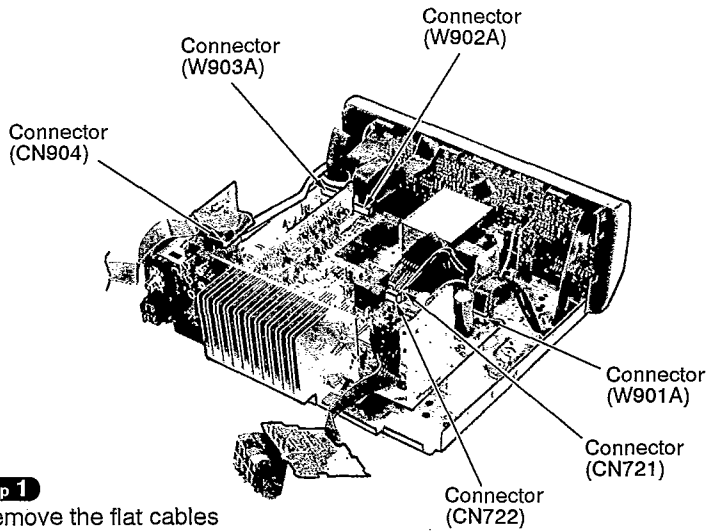

Step 1
Remove the flat cables from connectors.

Removal of the connector

- Connectors (W901A, W902A, W903A)

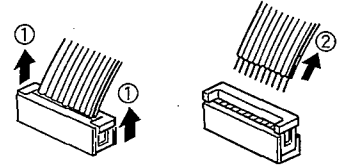

- Connectors (CN721, CN722, CN904)

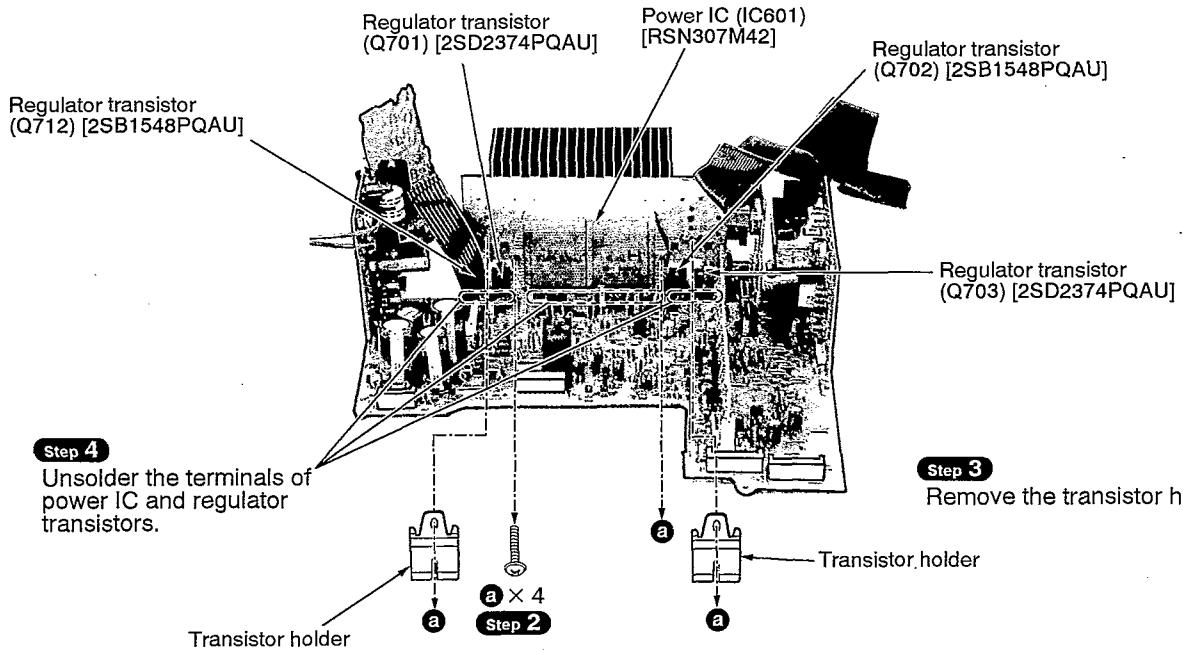
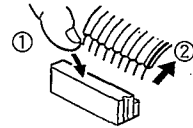

Step 4
Unsolder the terminals of power IC and regulator transistors.

Step 3
Remove the transistor holder.

NOTE

When mounting the power IC or regulator transistor apply silicone compound (RFKX0002) to the rear side of power IC or regulator transistors.

■ To Supply Power Source

This unit SA-EH500 is designed to operate on power supplied from the system connected. (For system connection, refer to Fig.1)

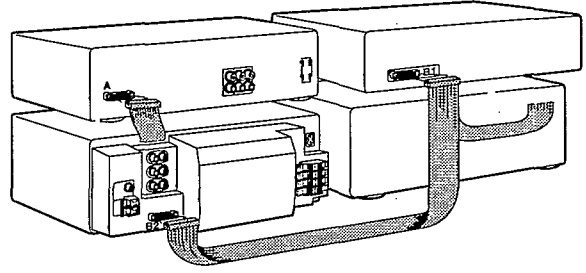

Fig. 1

When you have to test and service the unit SA-EH500 alone, use the following method to supply power source and operate the unit:

1. Short the section between 7 pin and 10 pin of the connector W202 in Fig. 2.
2. Connect this unit to an AC Power Cord.
(This unit come to stand-by mode.)
3. Turn the unit ON.

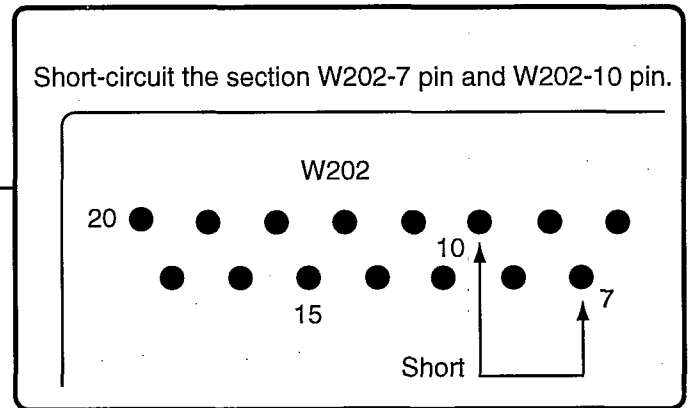
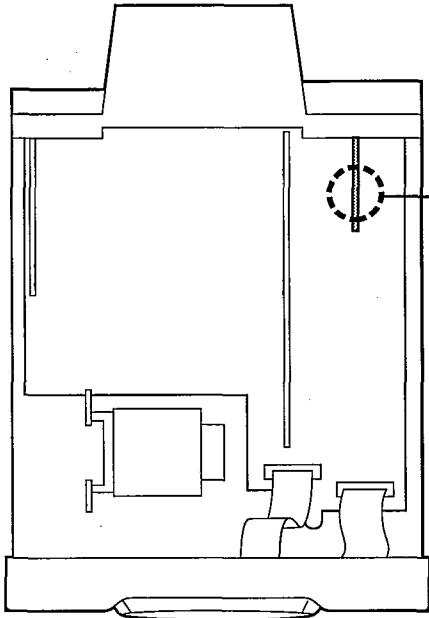

Fig. 2

■ To Check Operation

1. Set this unit to Power ON mode.
2. Input a signal and confirm it to be outputted from the speaker terminal.

	INPUT	OUTPUT
L-ch	EXT IN	L-ch speaker terminal
R-ch	EXT IN	L-ch speaker terminal

■ About the Self-Diagnostic Mode

This unit is equipped with a self-diagnostic function which, in the event of a malfunction, automatically displays a code indicating the nature of the malfunction. Use this self-diagnostic function when servicing the unit.

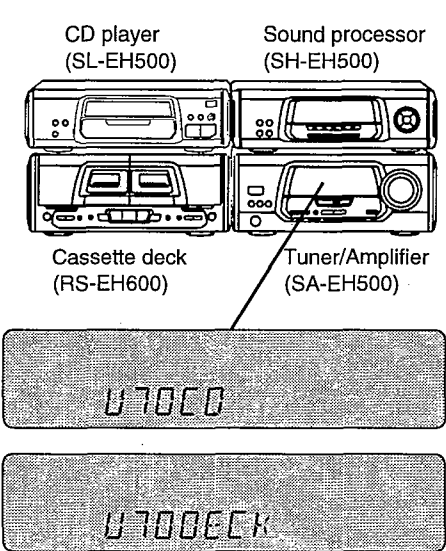
Display method	Display location
<p>To display the malfunction code</p> <p>U-70 CD: U-70 DECK: Automatically displays on the tuner/sound processor when a malfunction occurs.</p> <p>F-61 Automatically displays on the tuner/sound processor when a malfunction occurs.</p> <p>To return to the normal display</p> <p>1. For U-70 CD/U-70 DECK:</p> <ul style="list-style-type: none"> ● Press any operation button on the tuner/amplifier. ● To re-display the code, switch the power off (POWER STANDBY button), and then switch power back on again. <p>2. For F-61:</p> <ul style="list-style-type: none"> ● If "F-61" is displayed, the power will automatically be switched off and the standby indicator will light up. ● "F-61" will be displayed for 3 seconds, and then the clock will be displayed. ● To re-display the code, switch the power on. "F-61" will be re-displayed, and then after 3 seconds the clock will be displayed and the power will automatically switch off. 	 <p>CD player (SL-EH500) Sound processor (SH-EH500)</p> <p>Cassette deck (RS-EH600) Tuner/Amplifier (SA-EH500)</p> <p>U70CD</p> <p>U70DECK</p>

Display contents

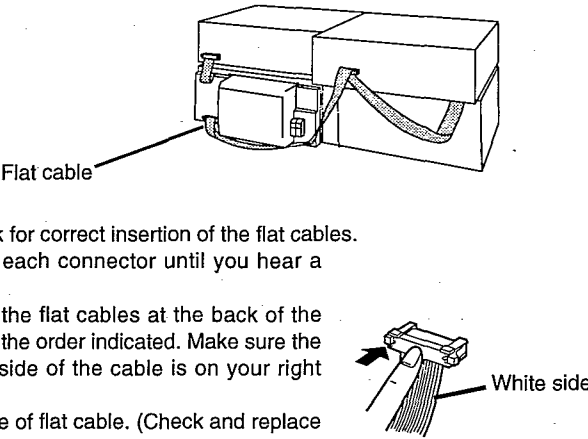
Display code	Problem or condition	Correction procedure
<p>U-70 CD U-70 DECK (displayed automatically)</p>	<p>A bus-line communications error has occurred as a result of the flat cables being inserted incorrectly, thus preventing the system from operating.</p> <p>1. If "U-70" is displayed on the tuner/amplifier, the tape deck or CD Changer cannot be operated by remote control.</p>	 <p>Flat cable</p> <p>White side</p> <ol style="list-style-type: none"> To check for correct insertion of the flat cables. <ol style="list-style-type: none"> Insert each connector until you hear a click. Insert the flat cables at the back of the unit in the order indicated. Make sure the white side of the cable is on your right side. Breakage of flat cable. (Check and replace as necessary.) If the problem is not corrected by items (1.) and (2.) above, this indicates a faulty IC. <p>SA-EH500: IC901 (M38199MF107K)</p> <p>SL-EH500: IC403 (LC66356C4K16)</p> <p>RS-EH600: IC701 (M37471M4679F)</p> <p>Check these IC's and replace as necessary.</p>
<p>F-61</p>	<p>When the power switch is switched on, it automatically switches back off, making it impossible to switch power on.</p>	<ul style="list-style-type: none"> ● Faulty Tuner/Amplifier (SA-EH500) output IC (IC601). (When a DC voltage is applied to the speaker terminals.)

■ Schematic Diagram

	Page		Page
A TUNER CIRCUIT	17, 18	F POWER SUPPLY CIRCUIT	28, 29
B OPERATION CIRCUIT	19 - 21	G SPEAKER TERMINAL CIRCUIT	29
C BTL CIRCUIT	22	H POWER TRANSFORMER (A) CIRCUIT	29
D IN/OUT TERMINAL CIRCUIT	23	I POWER TRANSFORMER (B) CIRCUIT	29
E MAIN CIRCUIT	23 - 28		

● This schematic diagram may be modified at any time with the development of new technology.

Notes:

- S901 : Power "STANDBY ϕ /ON" switch (POWER STANDBY ϕ /ON)
- S902 : Clock/timer switch (CLOCK/TIMER)
- S903 : Record timer switch (Ⓜ REC)
- S904 : Play timer switch (Ⓜ PLAY)
- S905 : Tuning mode select switch (TUNING MODE)
- S906 : Set switch (SET)
- S907 : FM mode select switch (FM AUTO/MONO)
- S908 : Source input select switch (INPUT SELECTOR)
- S909 : Tuning down switch (TUNING \vee)
- S910 : Tuning up switch (TUNING \wedge)
- S911 : Tuner/band select switch (TUNER/BAND)
- S912 : Super woofer switch (S.WOOFER)
- S913 : RDS display mode select switch (PS-DISP MODE)
- S914 : RDS display mode select switch (DISP MODE-PTY) } For (EG) and (EP) areas
- VR901 : Volume control (VOLUME)

- Indicated voltage values are the standard values for the unit measured by the DC electronic circuit tester (high-impedance) with the chassis taken as standard. Therefore, there may exist some errors in the voltage values, depending on the internal impedance of the DC circuit tester.
No mark: FM () : AM

● Important safety notice:

Components identified by \triangle mark have special characteristics important for safety.

Furthermore, special parts which have purposes of fire-retardant (resistors), high-quality sound (capacitors), low-noise (resistors), etc. are used. When replacing any of components, be sure to use only manufacturer's specified parts shown in the parts list.

● Caution!

IC and LSI are sensitive to static electricity.

Secondary trouble can be prevented by taking care during repair.

Cover the parts boxes made of plastics with aluminum foil.

Ground the soldering iron.

Put a conductive mat on the work table.

Do not touch the legs of IC or LSI with the fingers directly.

● Voltage and signal line

 : Positive voltage line

 : Negative voltage line

 : AM signal Line

 : AM OSC signal line

 : FM signal line

 : FM OSC signal line

A TUNER CIRCUIT (P.C.Board: on page 30)

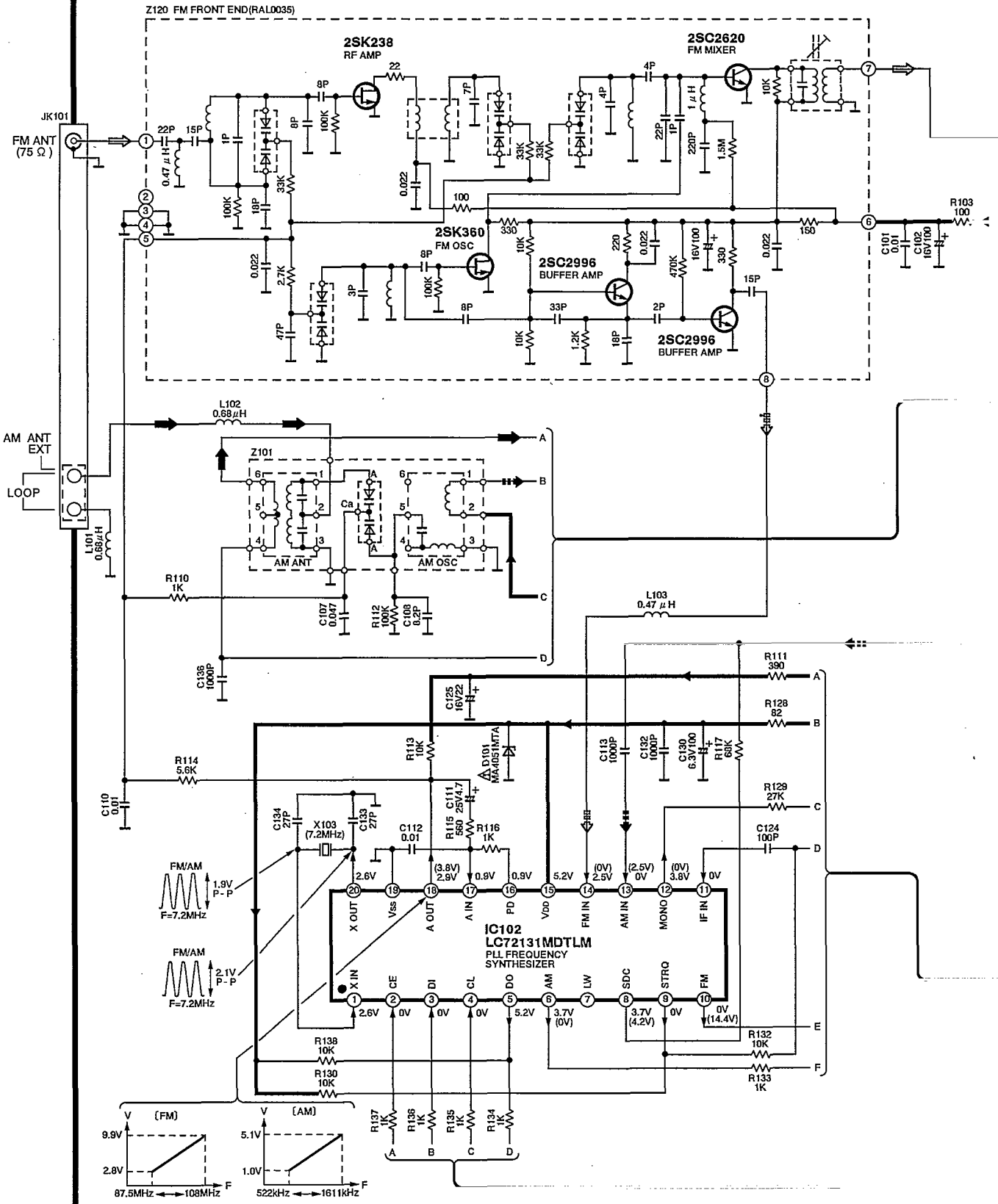

➔ : Positive voltage line
 ■■■➔ : AM OSC signal line

---➔ : Negative voltage line
 ➔ : FM signal line

➔ : AM signal Line

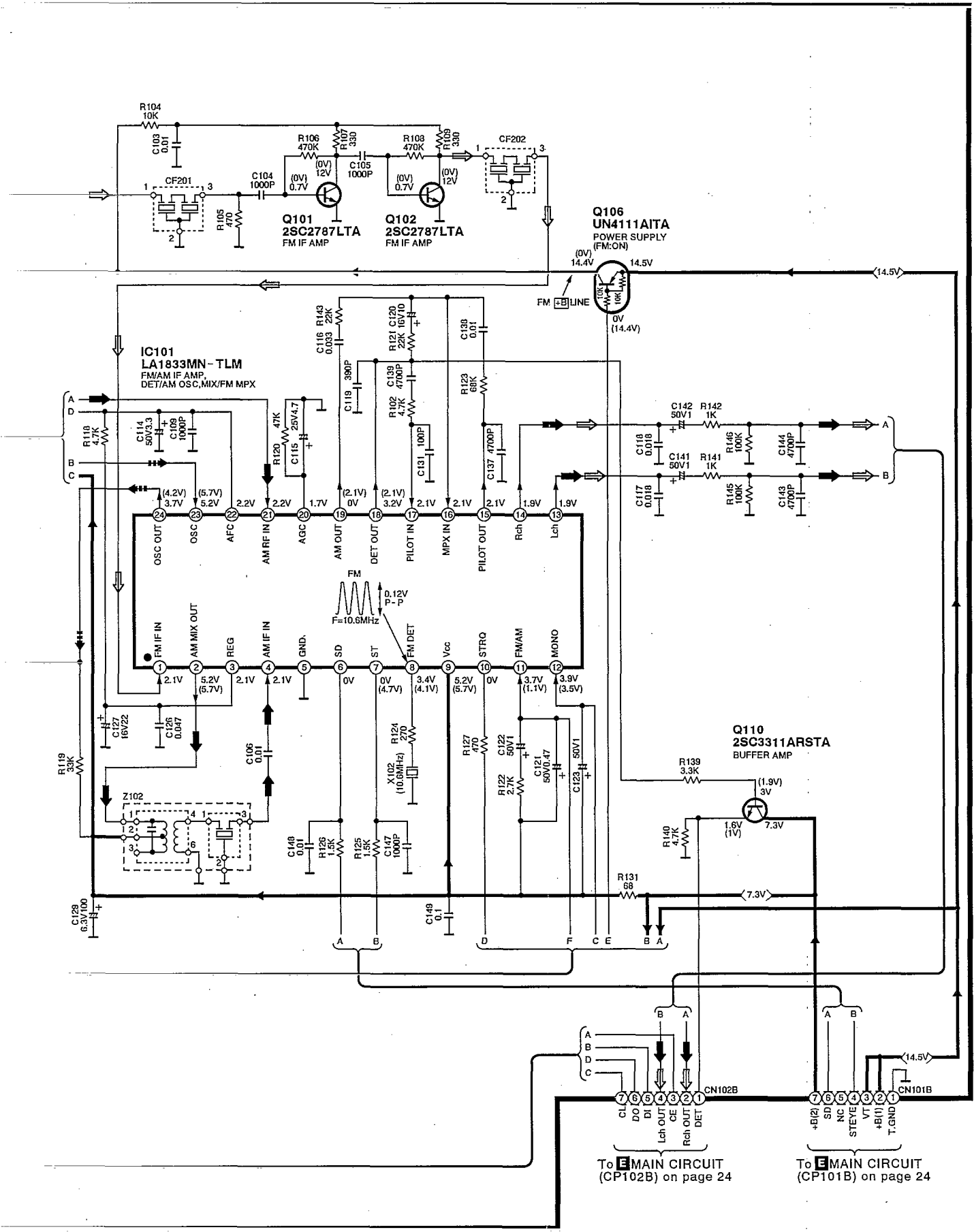

To MAIN CIRCUIT (CP102B) on page 24

To MAIN CIRCUIT (CP101B) on page 24

B OPERATION CIRCUIT (P.C.Board: on page 30)

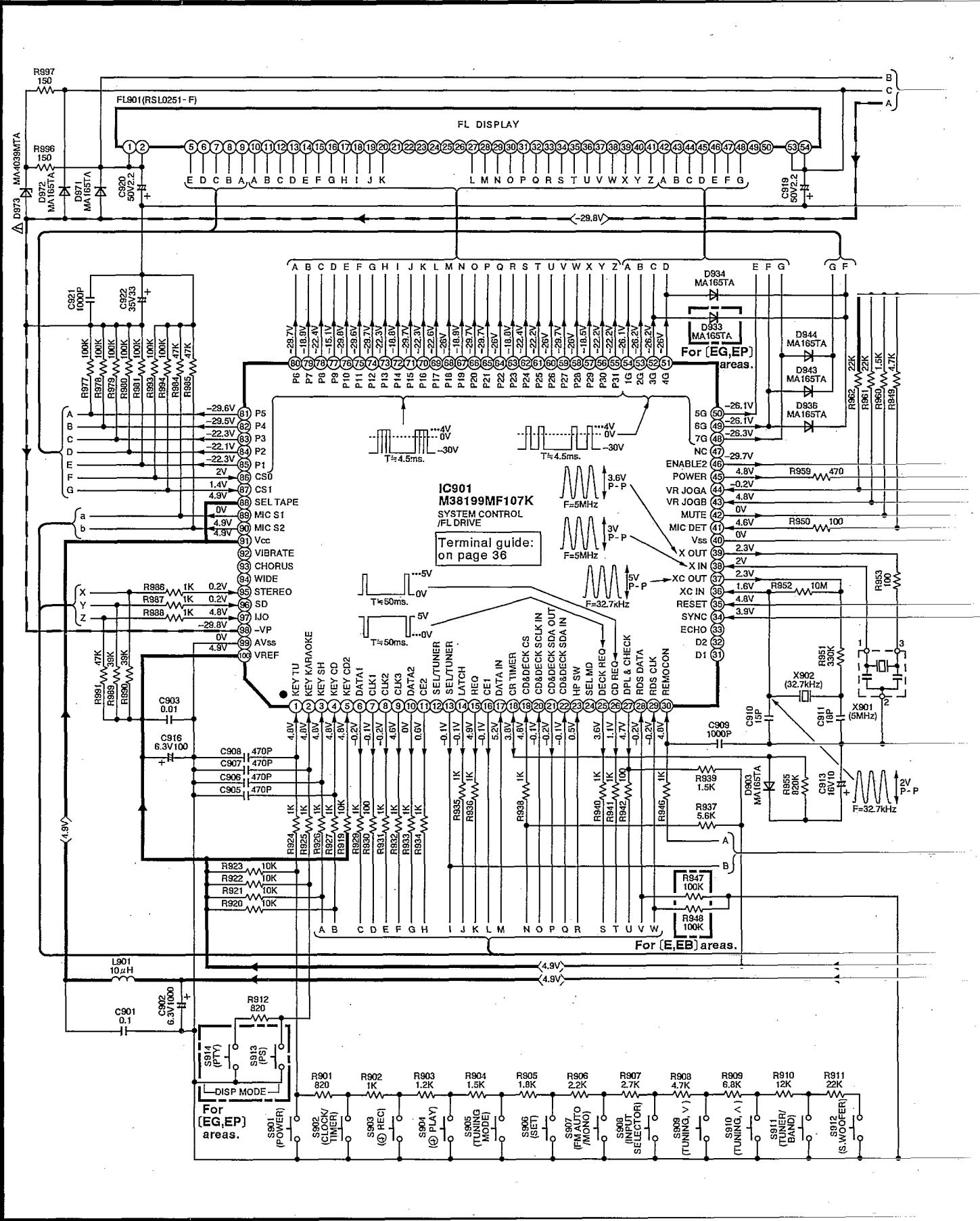

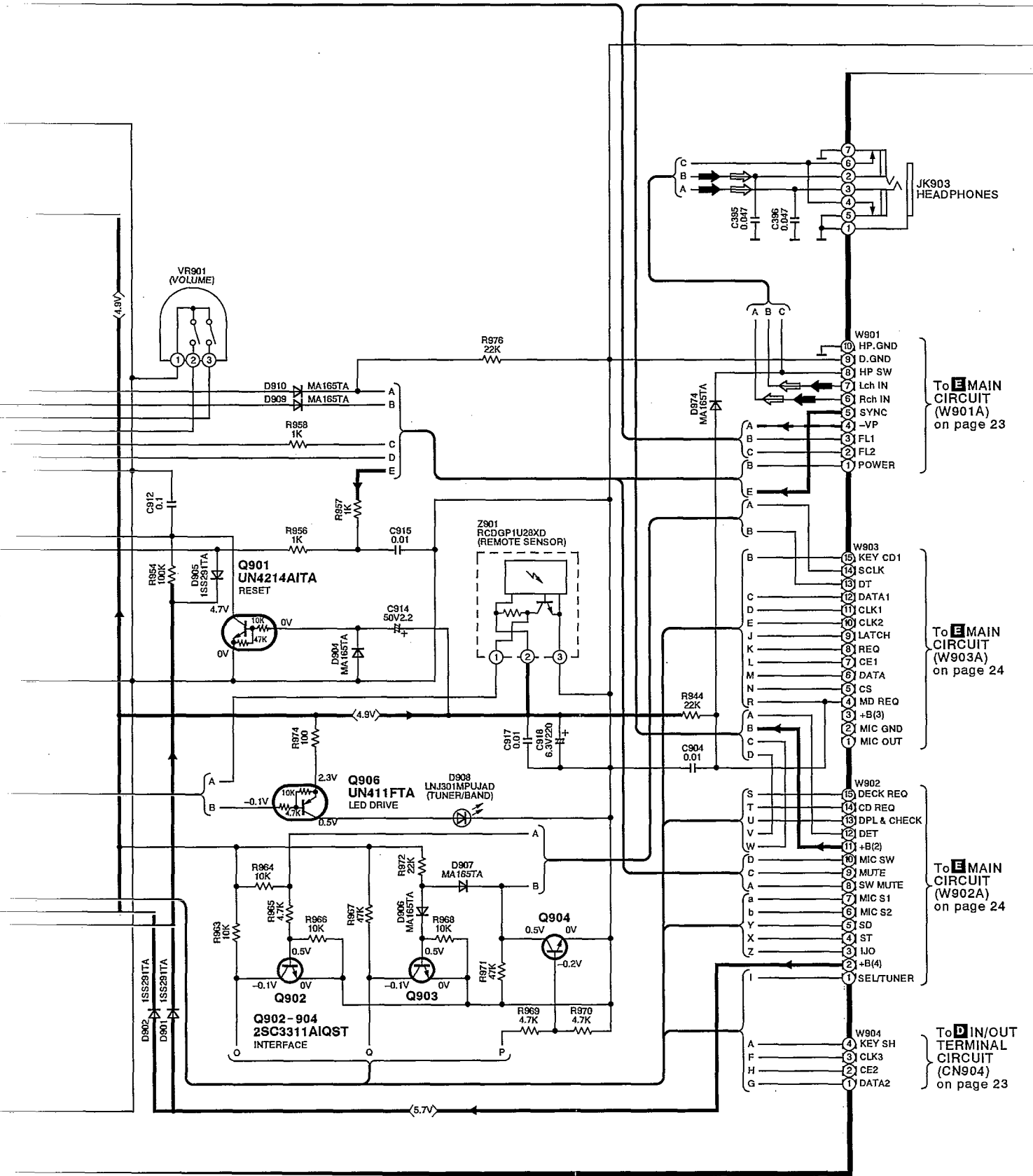

B OPERATION CIRCUIT (P.C.Board: on page 30)

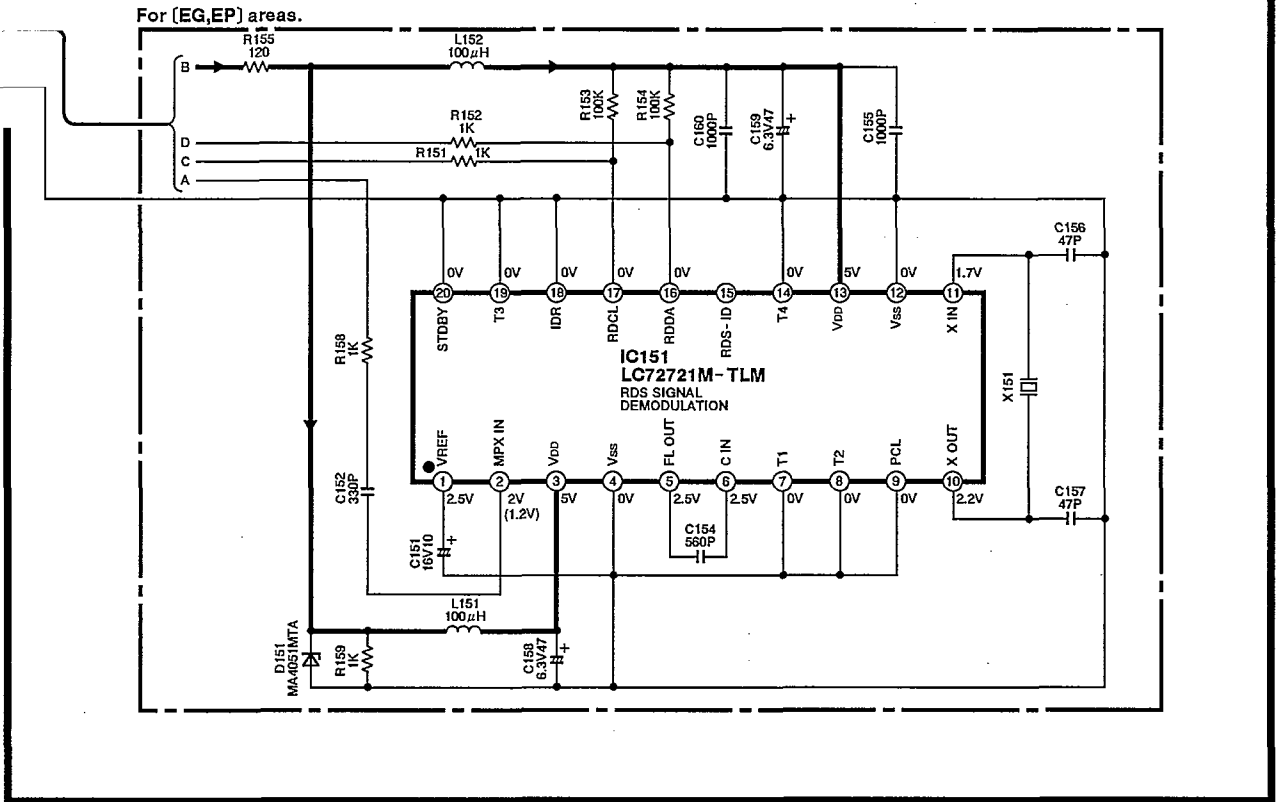

C BTL CIRCUIT (P.C.Board: on page 31)

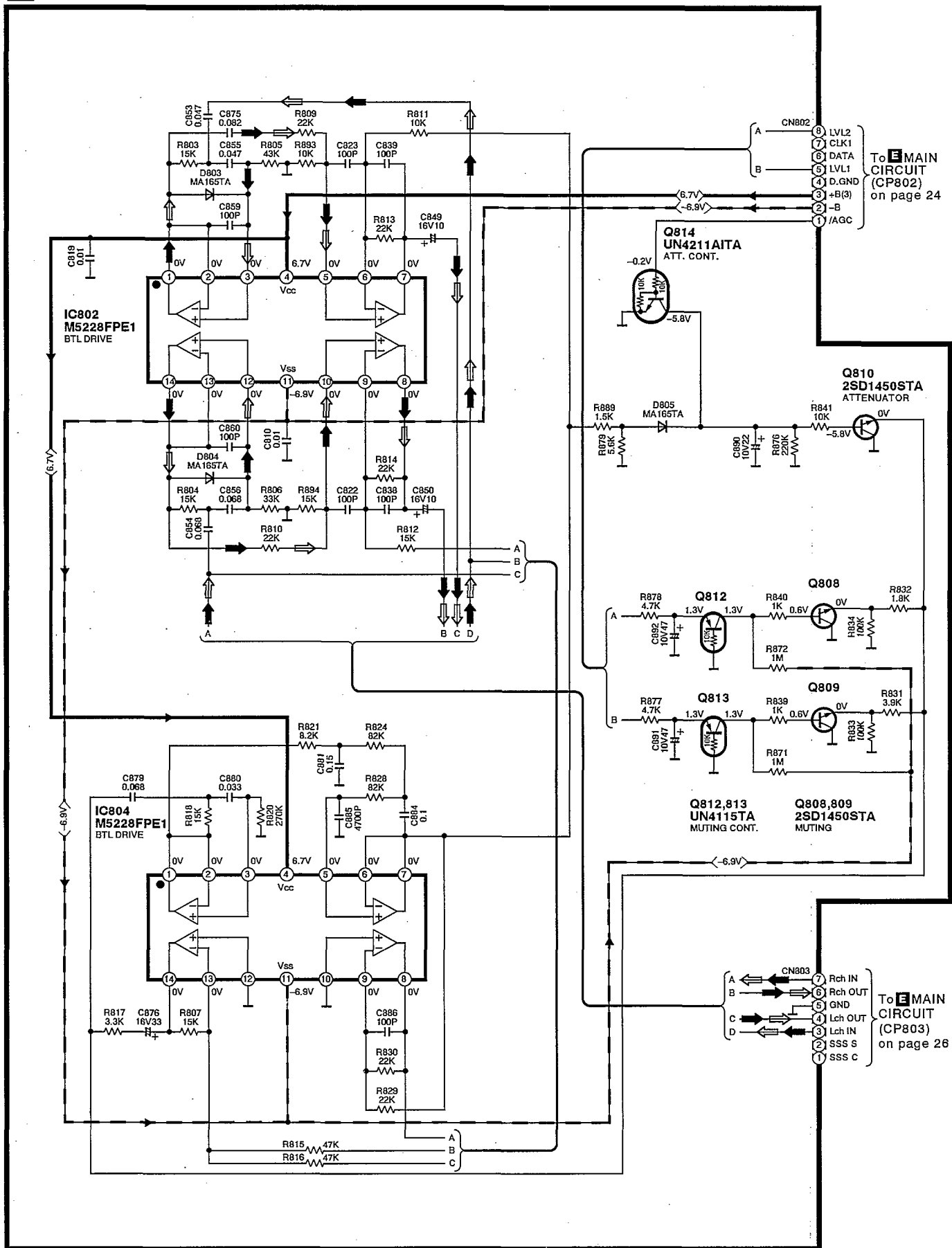

To **E** MAIN CIRCUIT (CP802) on page 24

To **E** MAIN CIRCUIT (CP803) on page 26

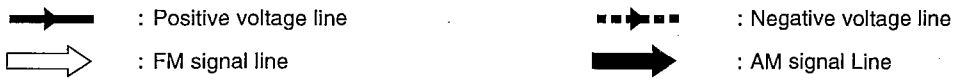

D IN/OUT TERMINAL CIRCUIT (P.C.Board: on page 31)

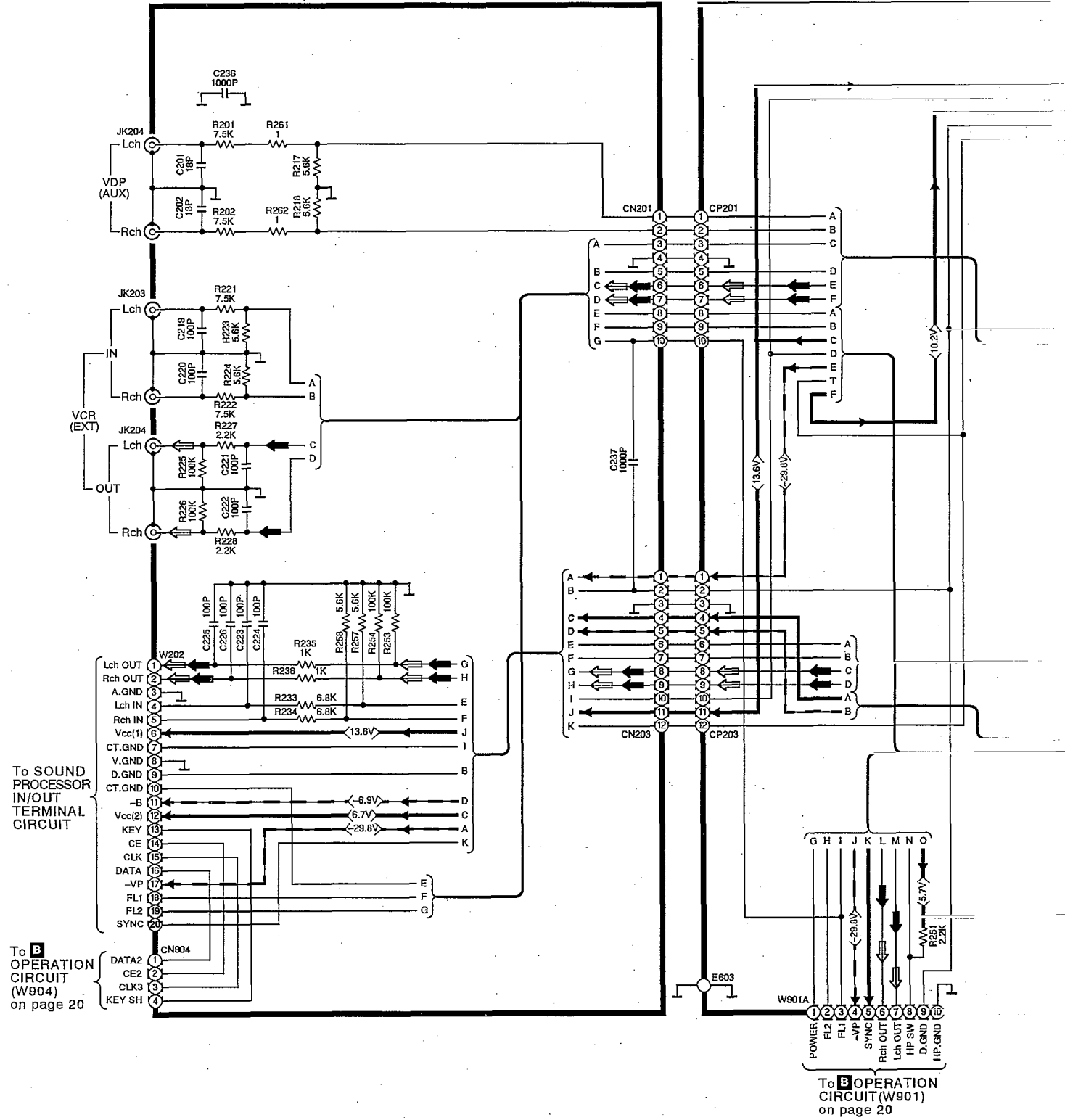

E MAIN CIRCUIT (P.C.Board: on pages 32,33)



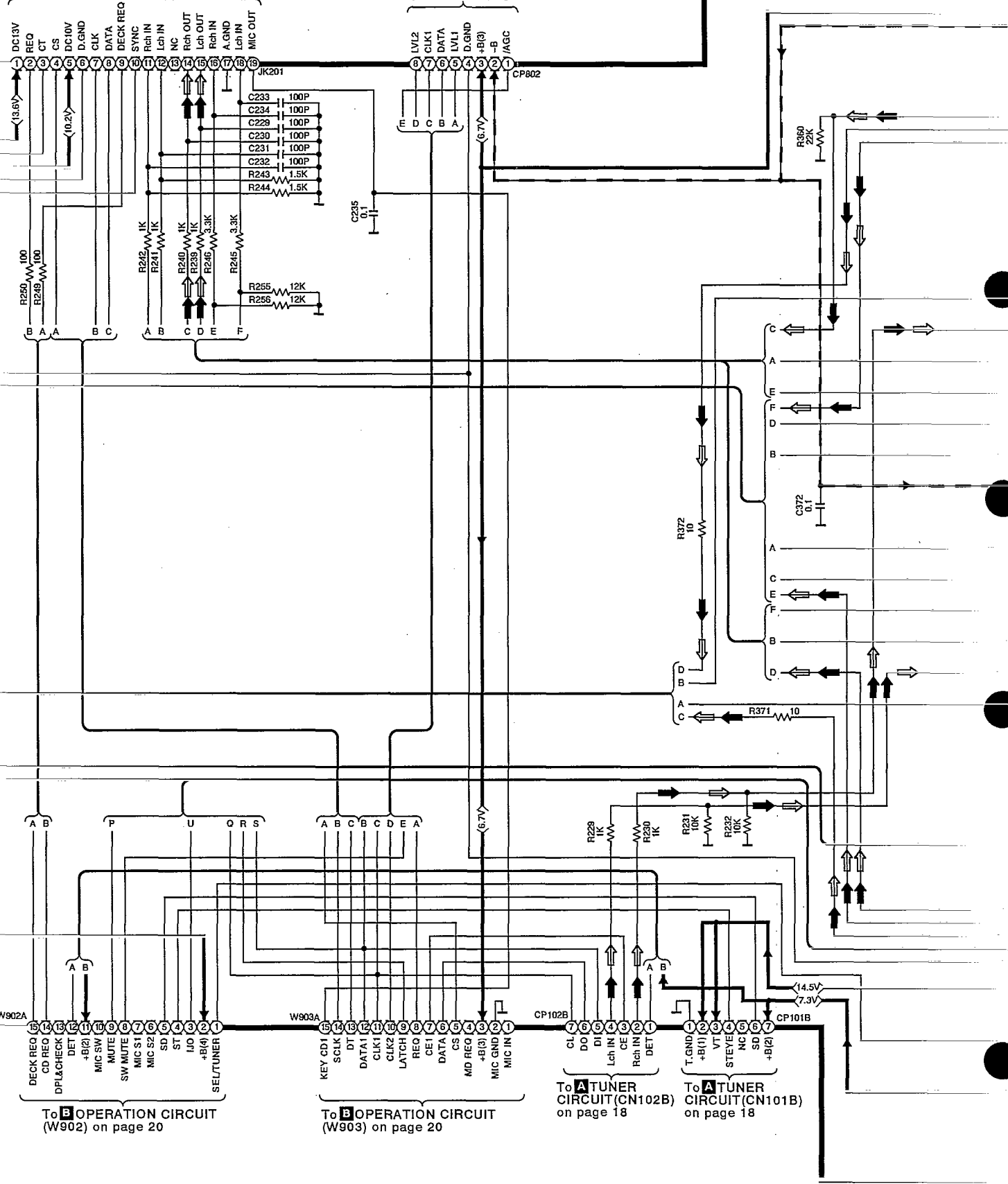

To CASSETTE DECK POWER SUPPLY CIRCUIT
To CD PLAYER MAIN CIRCUIT

To BTL
CIRCUIT
(CN802) on page 22



 : Positive voltage line
 : FM signal line

 : Negative voltage line
 : AM signal Line

E MAIN CIRCUIT (P.C.Board: on pages 32,33)

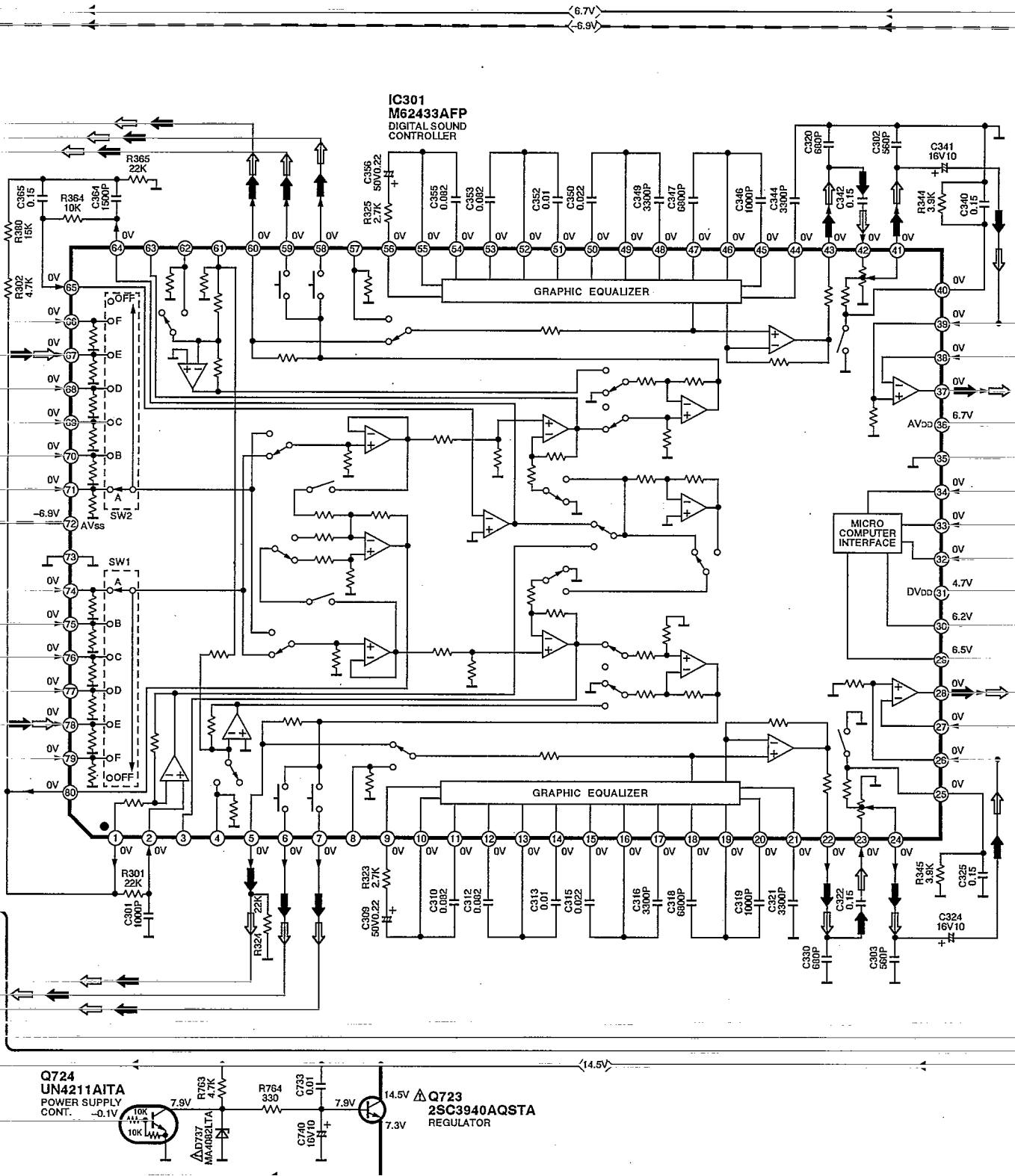

E MAIN CIRCUIT (P.C.Board: on pages 32,33)

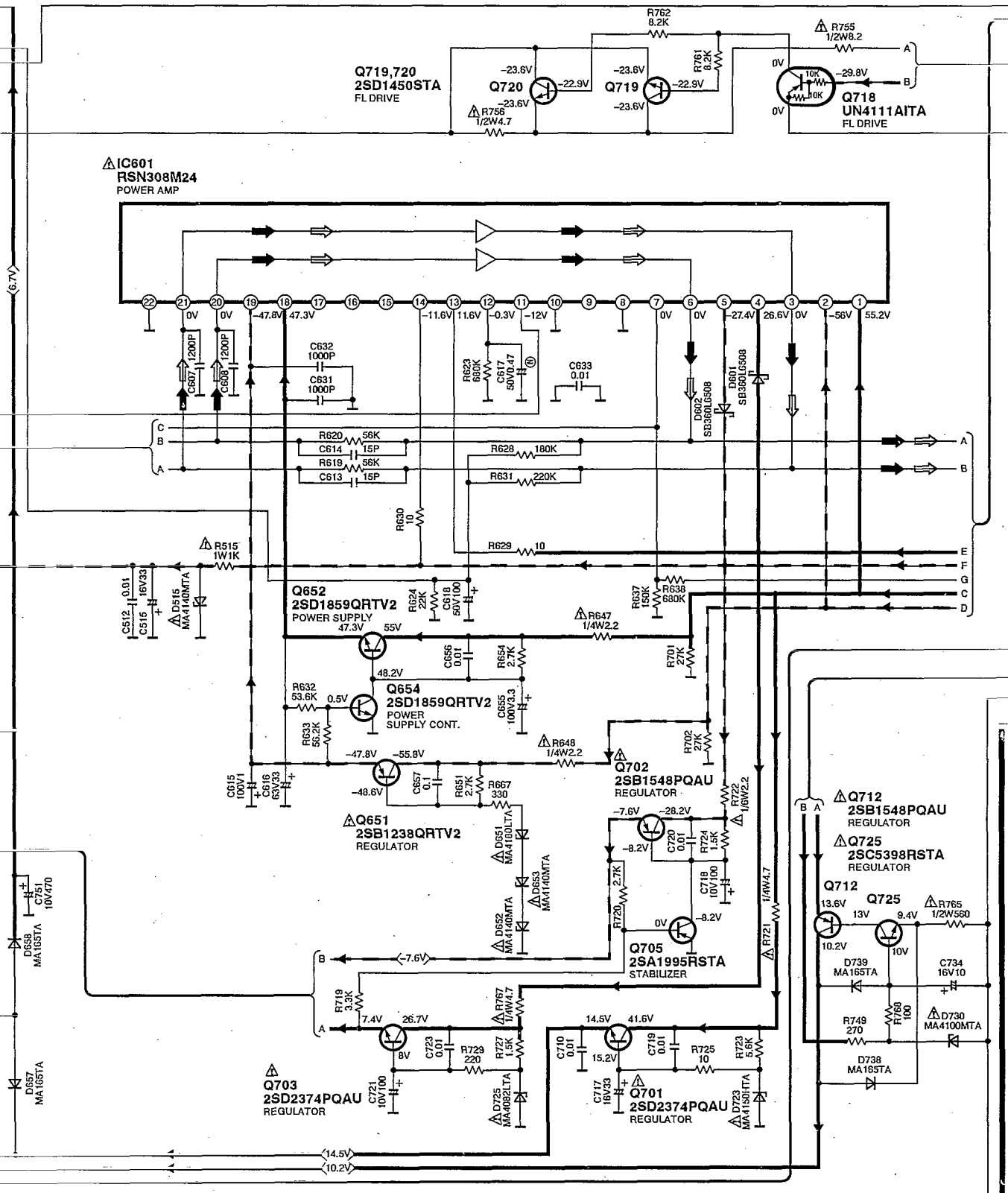

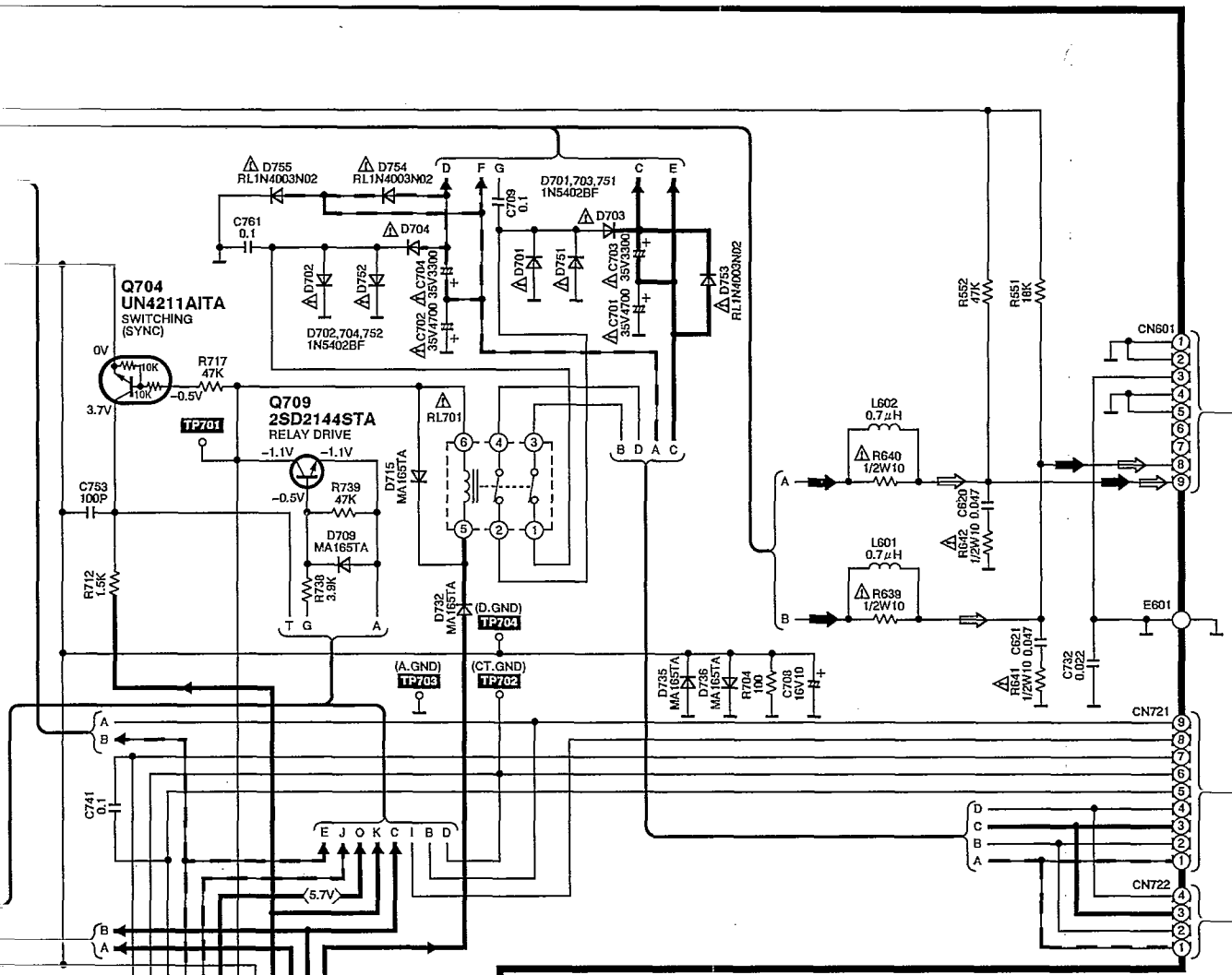

F POWER SUPPLY CIRCUIT (P.C. Board: on page 33)

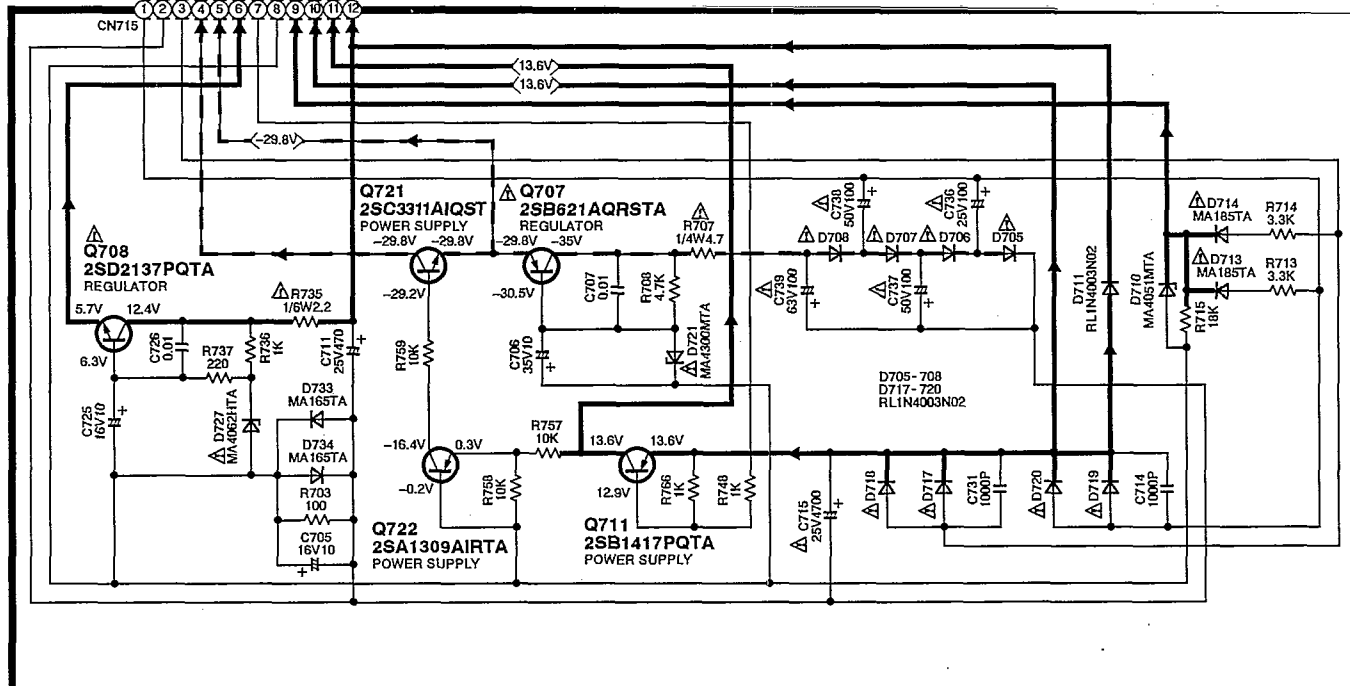



G SPEAKER TERMINAL CIRCUIT
(P.C.Board: on page 33)

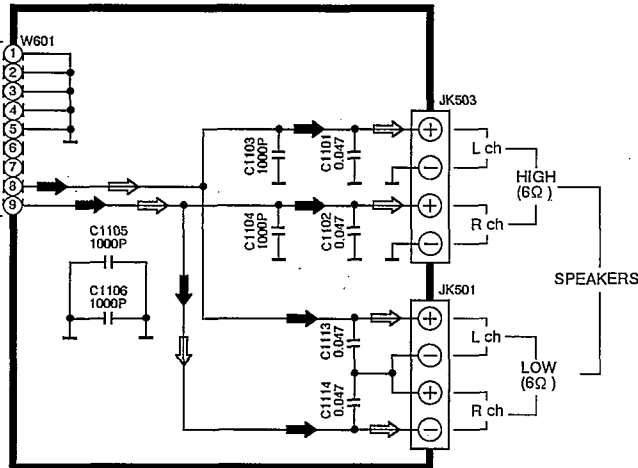

H POWER TRANSFORMER
(A) CIRCUIT
(P.C.Board: on page 31)

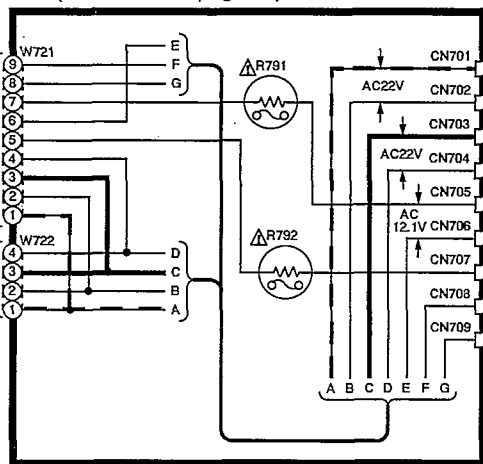

I POWER TRANSFORMER
(B) CIRCUIT
(P.C.Board: on page 31)

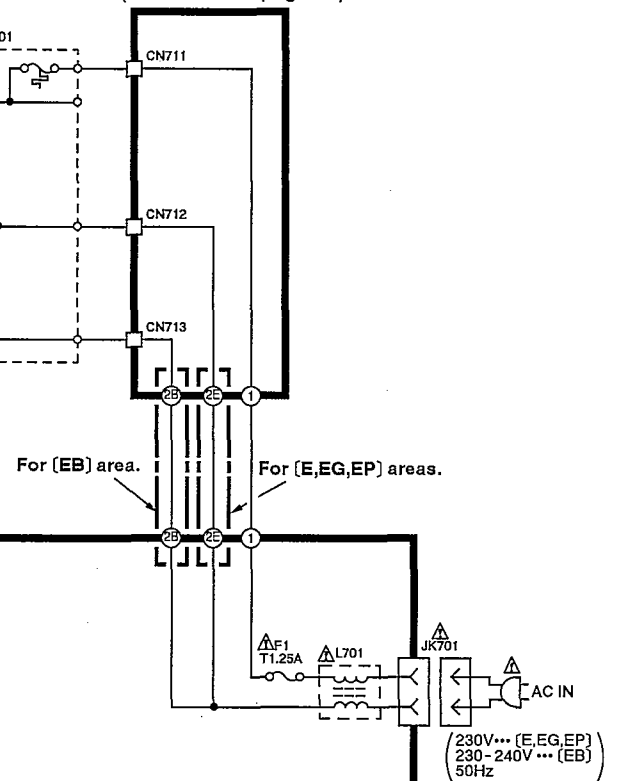

Printed Circuit Board Diagram

• This circuit board diagram may be modified at any time with the development of new technology.

A TUNER P.C.B.

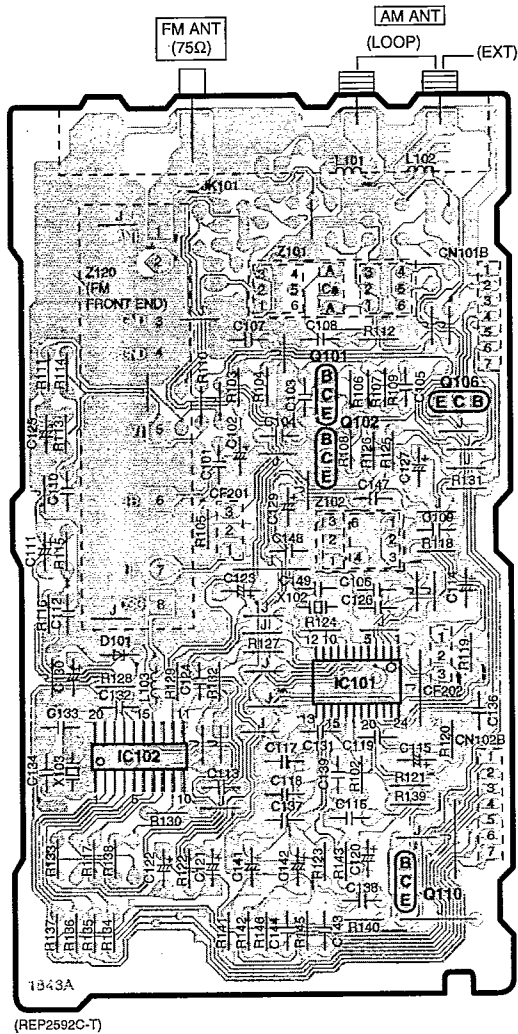

B OPERATION P.C.B.

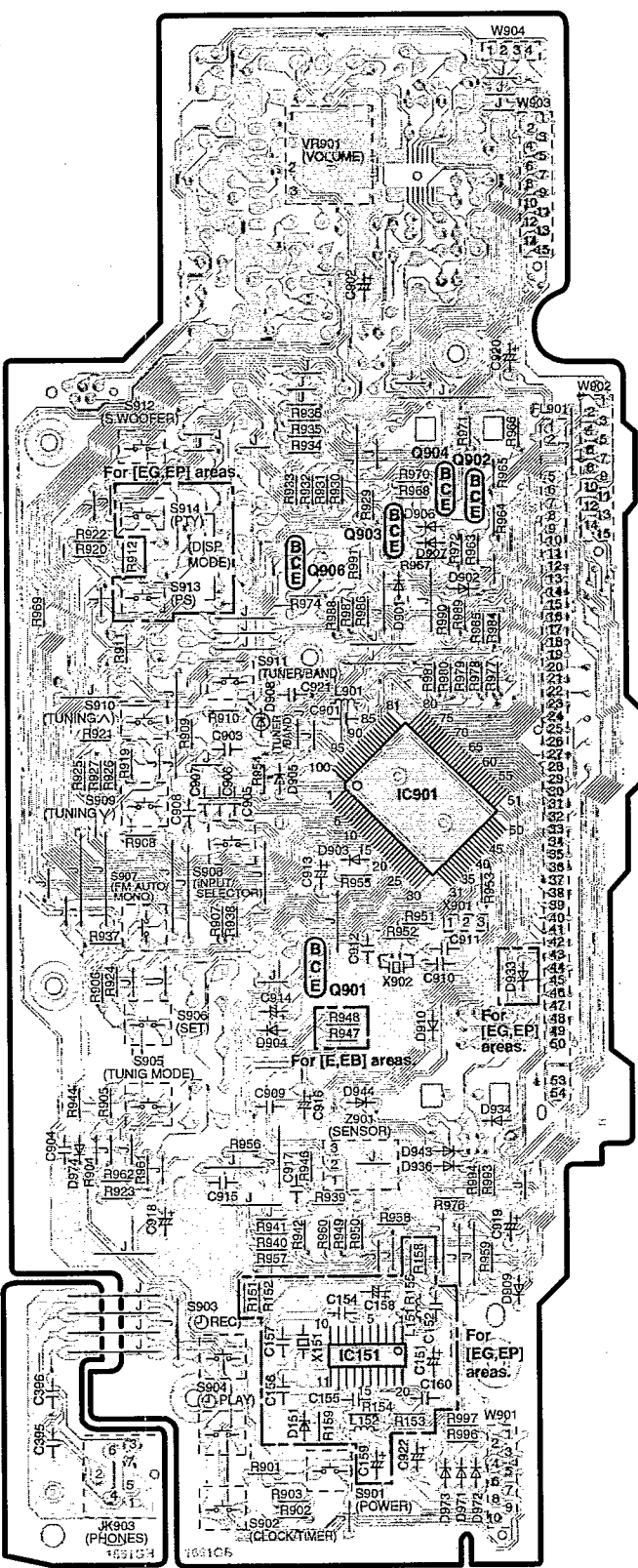

(REP2642A-M...[E]
 REP2642B-M...[EG,EP]
 REP2642C-M...[EB])

D IN / OUT TERMINAL P.C.B.

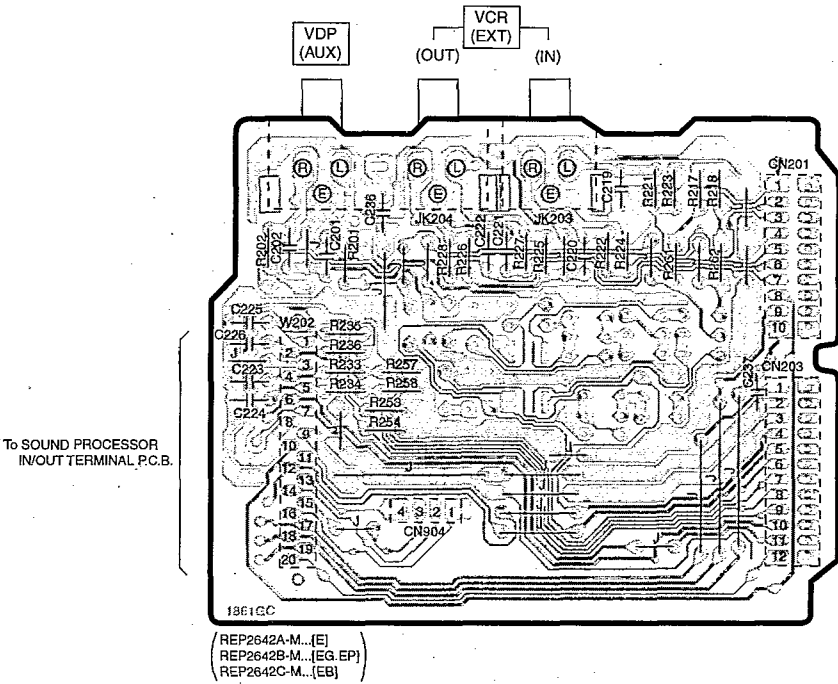

To SOUND PROCESSOR
IN/OUT TERMINAL P.C.B.

H POWER TRANSFORMER (A) P.C.B.

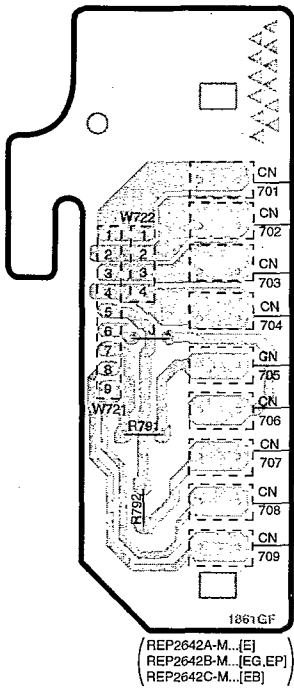

I POWER TRANSFORMER (B) P.C.B.

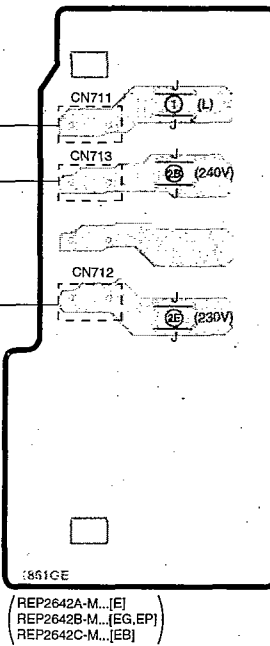

C BTL P.C.B.

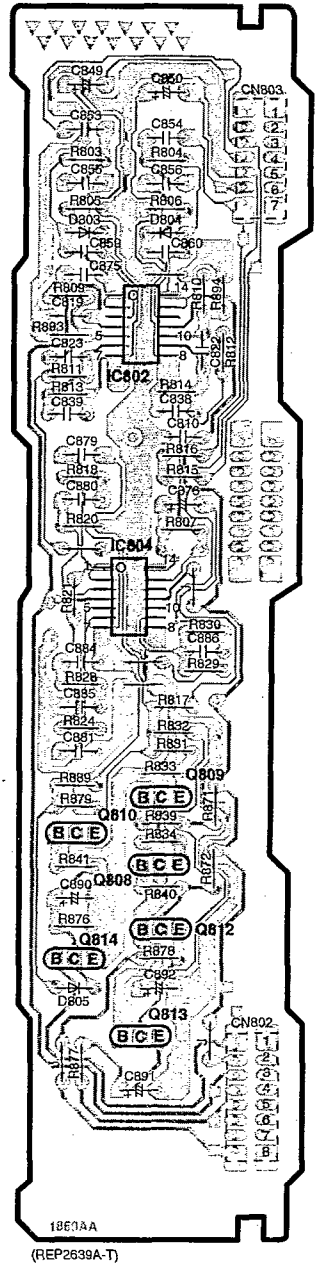

To CASSETTE DECK POWER SUPPLY P.C.B.
To CD PLAYER MAIN P.C.B.

E MAIN P.C.B.

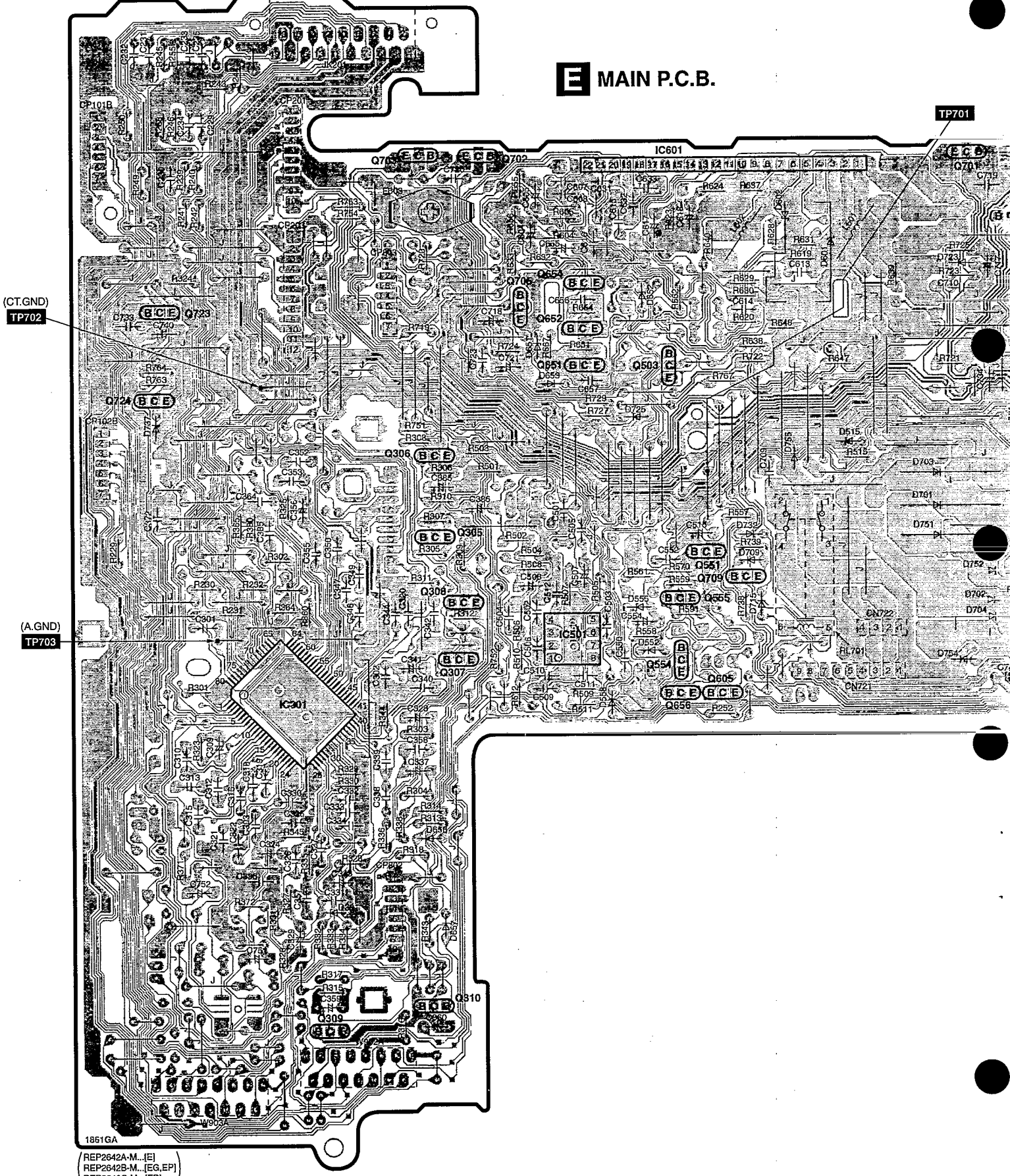

F POWER SUPPLY P.C.B.

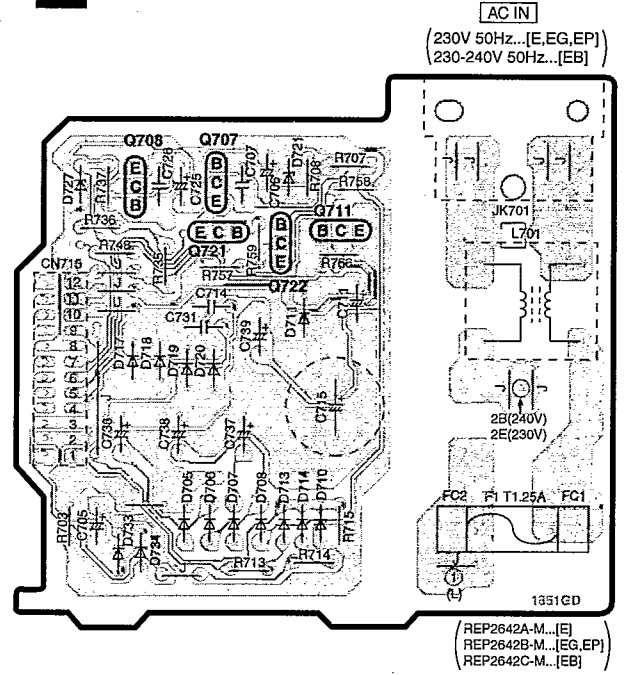
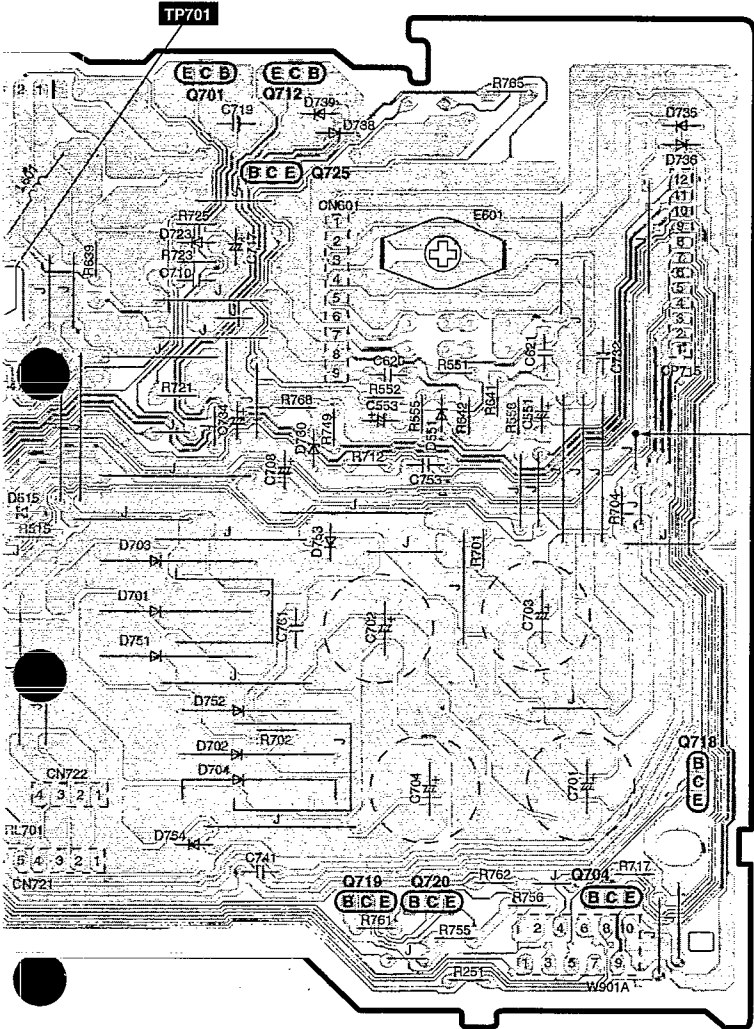

Wiring Connection Diagram

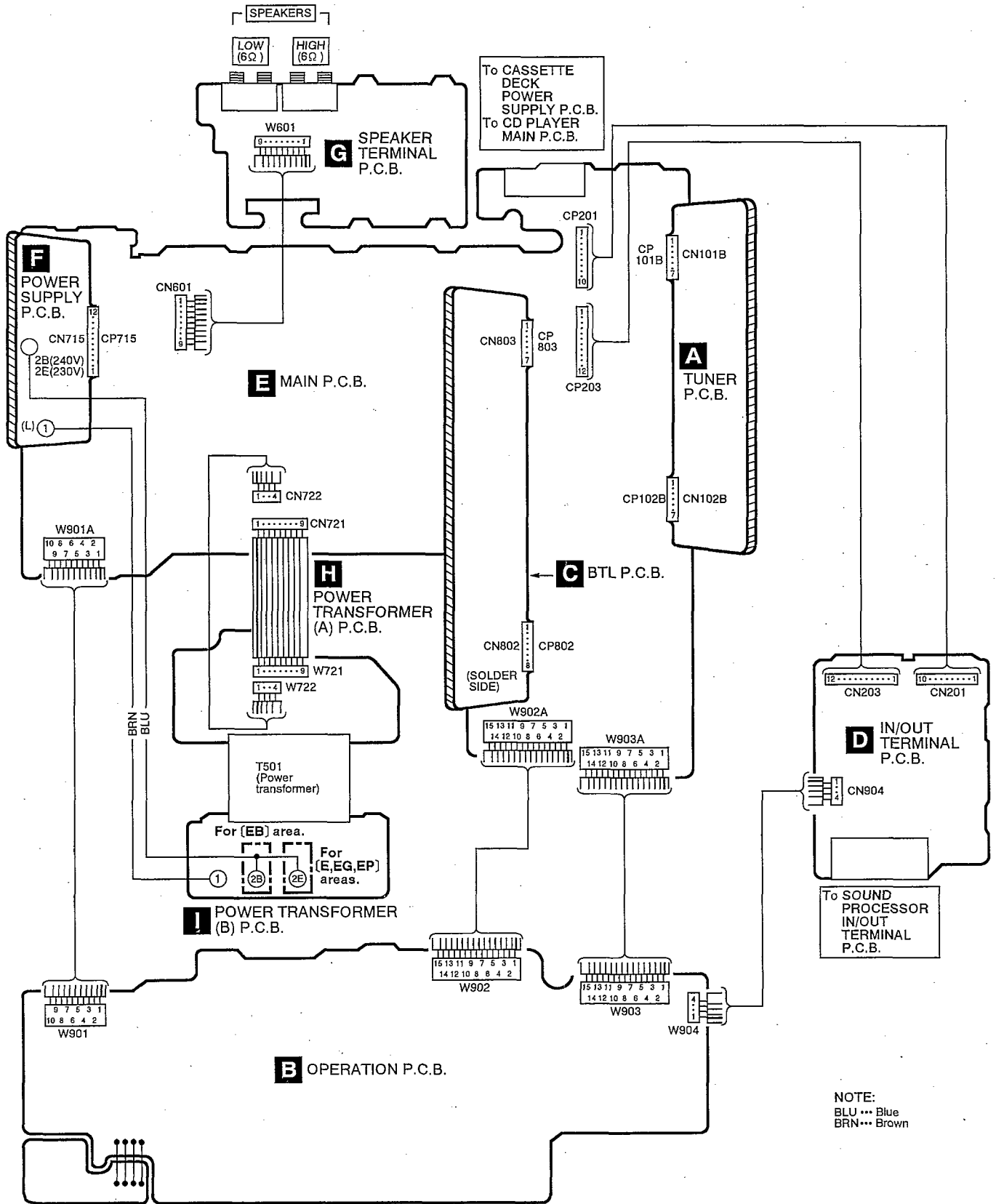

NOTE:
 BLU... Blue
 BRN... Brown

■ Type Illustration of IC's, Transistors and Diodes

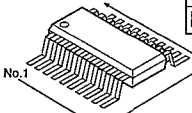
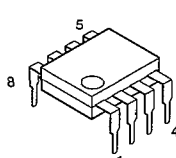
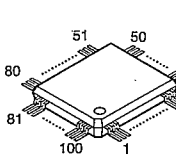
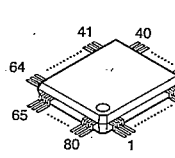
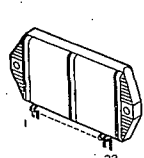
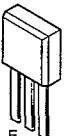
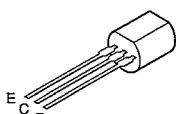
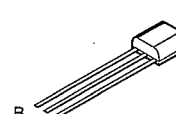
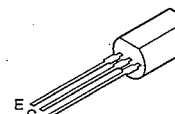
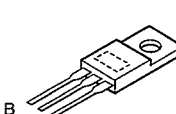
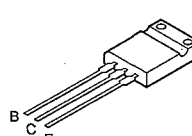
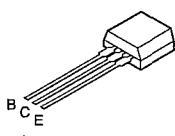
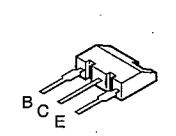
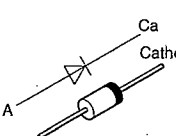
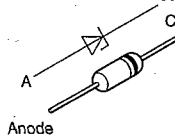
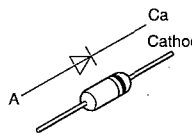
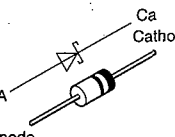
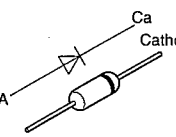
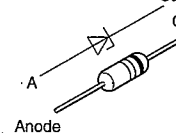
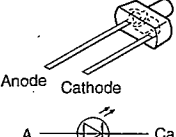
<table border="1"> <tr> <td>LA1833MN-TLM</td> <td>24PIN</td> </tr> <tr> <td>LC72131MDTLM</td> <td>20PIN</td> </tr> <tr> <td>LC72721M-TLM</td> <td>20PIN</td> </tr> <tr> <td>M5228FPE1</td> <td>14PIN</td> </tr> </table> 		LA1833MN-TLM	24PIN	LC72131MDTLM	20PIN	LC72721M-TLM	20PIN	M5228FPE1	14PIN	<p>M5218AP</p> 	<p>M38199MF107K</p> 	<p>M62433AFP</p> 	<p>RSN308M24</p> 
LA1833MN-TLM	24PIN												
LC72131MDTLM	20PIN												
LC72721M-TLM	20PIN												
M5228FPE1	14PIN												
 <p>2SA1309AIRTA UN411FTA 2SC2787LTA UN4111AITA 2SC3311AIQST UN4115TA 2SC3311ARSTA UN4211AITA 2SD1450STA UN4214AITA</p>		<p>2SB621AQRSTA</p> 	<p>2SA1995RSTA 2SC5398RSTA</p> 	<p>2SC3940AQSTA</p> 	<p>2SB1548PQAU 2SD2374PQAU</p> 								
<p>2SB1417PQTA 2SD2137PQTA</p> 	<p>2SD2144STA</p> 	<p>2SB1238QRTV2 2SD1859QRTV2</p> 	<p>1N5402BF RL1N4003N02</p> 	 <p>MA4100MTA MA4140MTA MA4150HTA MA4180LTA MA4300MTA</p>									
<p>MA185TA</p> 	<p>SB360L6508</p> 	<p>MA165TA 1SS291TA</p> 	 <p>MA4039MTA MA4051LTA MA4051MTA MA4062HTA MA4082LTA</p>	<p>LNJ301MPUJAD</p> 									

Terminal Function of IC's

• IC901 (M38199MF107K): System Control / FL Drive

Pin No.	Terminal Name	I/O	Function
1	KEY TU	I	Operation switch signal input (TUNER, TIMER, AMP. section)
2	KEY KRAOKE	I	Operation switch signal input (DISP MODE section)
3	KEY SH	I	Sound processor operation switch signal input
4	KEY CD	I	CD player operation switch signal input
5	KEY CD2	I	Connected to VREF
6	DATA1	O	Data signal output for M62433 and LC72131
7	CLK1	O	Clock signal output for M62433 and LC72131
8	CLK2	O	BTL drive control signal output
9	CLK3	O	Serial communication signal to sound processor (Clock signal output)
10	DATA2	O	Serial communication signal to sound processor (Data signal output)
11	CE2	O	Serial communication signal to sound processor (Chip enable signal output)
12	SEL/TUNER	O	Not used
13	SEL/TUNER	O	Tuner circuit power control and LED (D908) drive signal output
14	LATCH	O	Latch signal output to M62433
15	REQ	O	BTL drive control signal output
16	CE1	O	Chip enable signal output to LC72131
17	DATA IN	I	Data signal input from LC72131
18	CR TIMER	I/O	TIME CONSTANT terminal
19	CD & DECK CS	I	Serial data communication starting signal input (CD and DECK mechanism)
20	CD & DECK SCLK IN	I	Serial clock input (CD and DECK mechanism)
21	CD & DECK SDA OUT	O	Serial data output (CD and DECK mechanism)
22	CD & DECK SDA IN	I	Serial data input (CD and DECK mechanism)
23	HP SW	I	Headphones connecting detect signal input
24	SEL MD	O	Not used
25	DECK REQ	O	Cassette deck request signal output
26	CD REQ	O	CD player request signal output
27	DPL & CHECK	O	Not used
28	RDS DATA	I	RDS data input
29	RDS CLK	I	RDS clock input
30	REMOCON	I	Remote control signal input
31, 32	D1, D2	O	Not used
33	ECHO	O	

Pin No.	Terminal Name	I/O	Function
34	SYNC	I	AC power source input terminal
35	RESET	I	Reset signal input
36	XC IN	I	Oscillator connected terminal (f = 32.7 kHz)
37	XC OUT	O	
38	X IN	I	Oscillator connected terminal (f = 5 MHz)
39	X OUT	O	
40	Vss	—	GND terminal
41	MIC DET	I	Not used
42	MUTE	O	Muting signal output
43	VR JOGB	I	Volume control signal input
44	VR JOGA	I	
45	POWER	O	Power control signal output
46	ENABLE2	O	Attenuator control signal output
47	NC	—	No used
48~54	7G~1G	O	Grid signal and chip select scan signal output
55~85	P31~P1	O	Segment signal output
86, 87	CS0, CS1	I	Chip select signal input
88	SEL TAPE	O	Connected to VCC
89	MIC S1	O	Not used
90	MIC S2	O	Not used
91	VCC	—	Power supply
92	VIBRATE	O	Not used
93	CHORUS	O	Not used
94	WIDE	O	Not used
95	STEREO	I	STEREO signal input for tuner circuit
96	SD	I	Station detector signal input for tuner circuit
97	IJO	I	Unusual condition detect terminal ("L": unusual)
98	-VP	—	Reference voltage input (negative)
99	AVSS	—	Connect to GND
100	VREF	—	Reference voltage input (positive)

Block Diagram

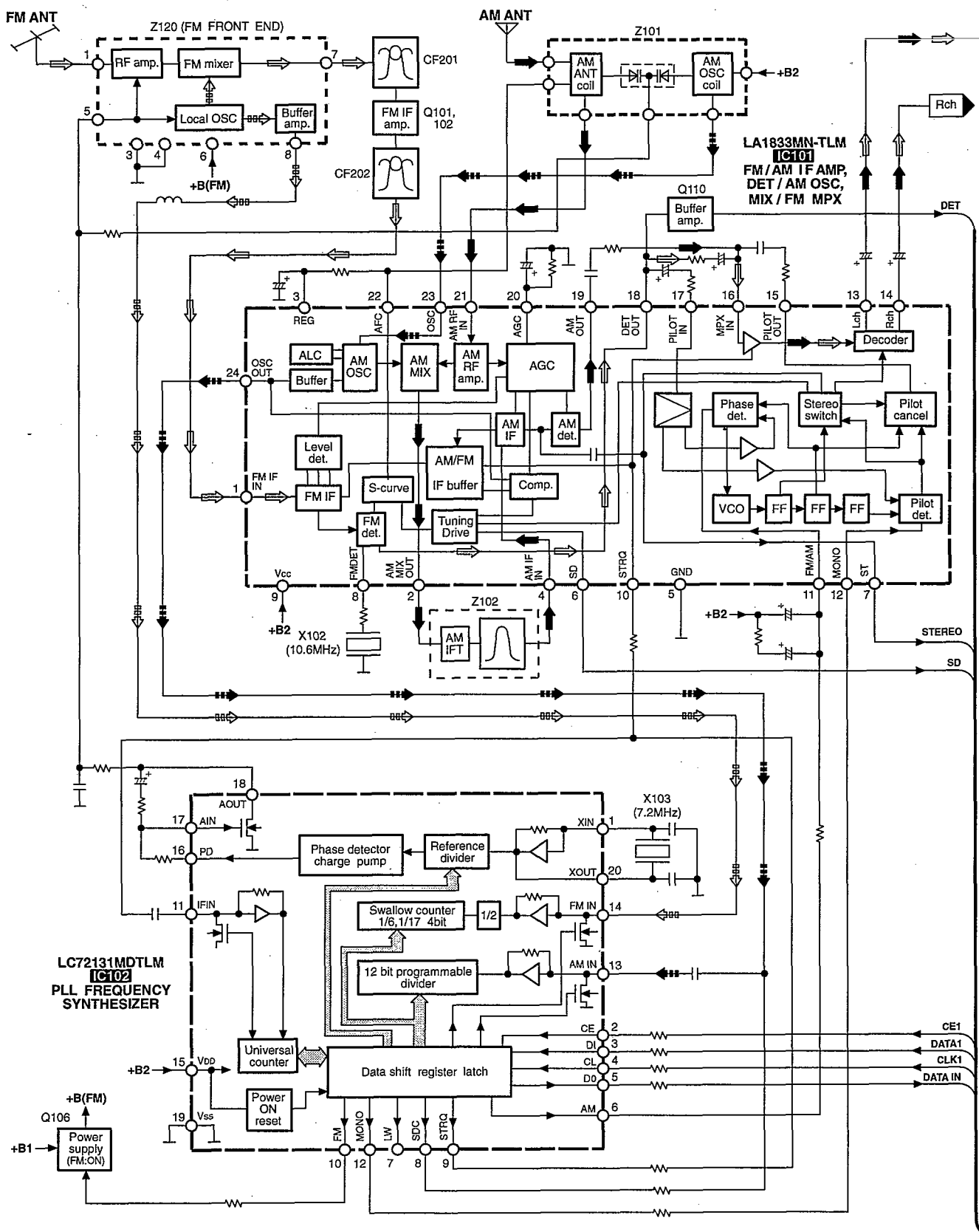

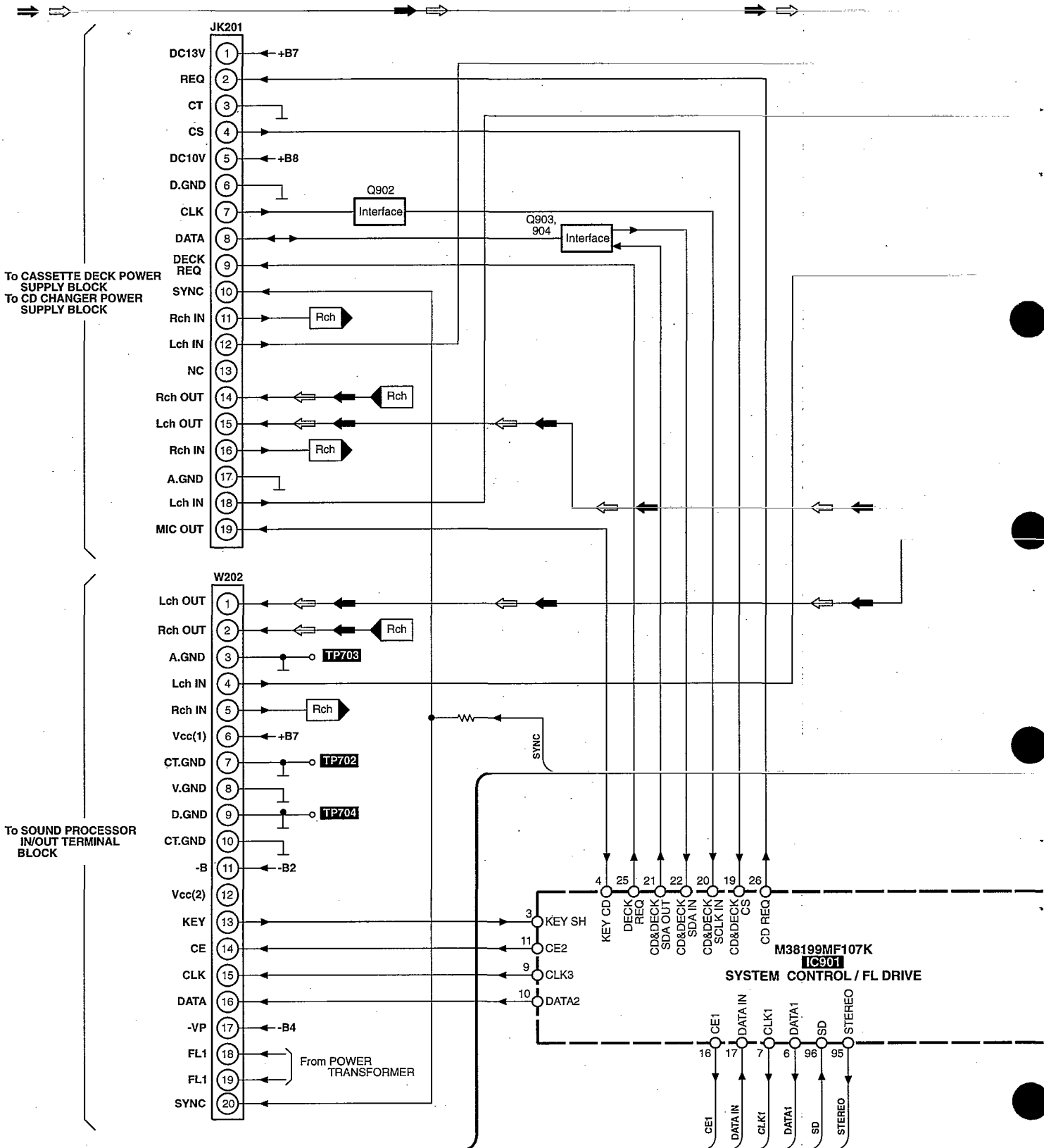

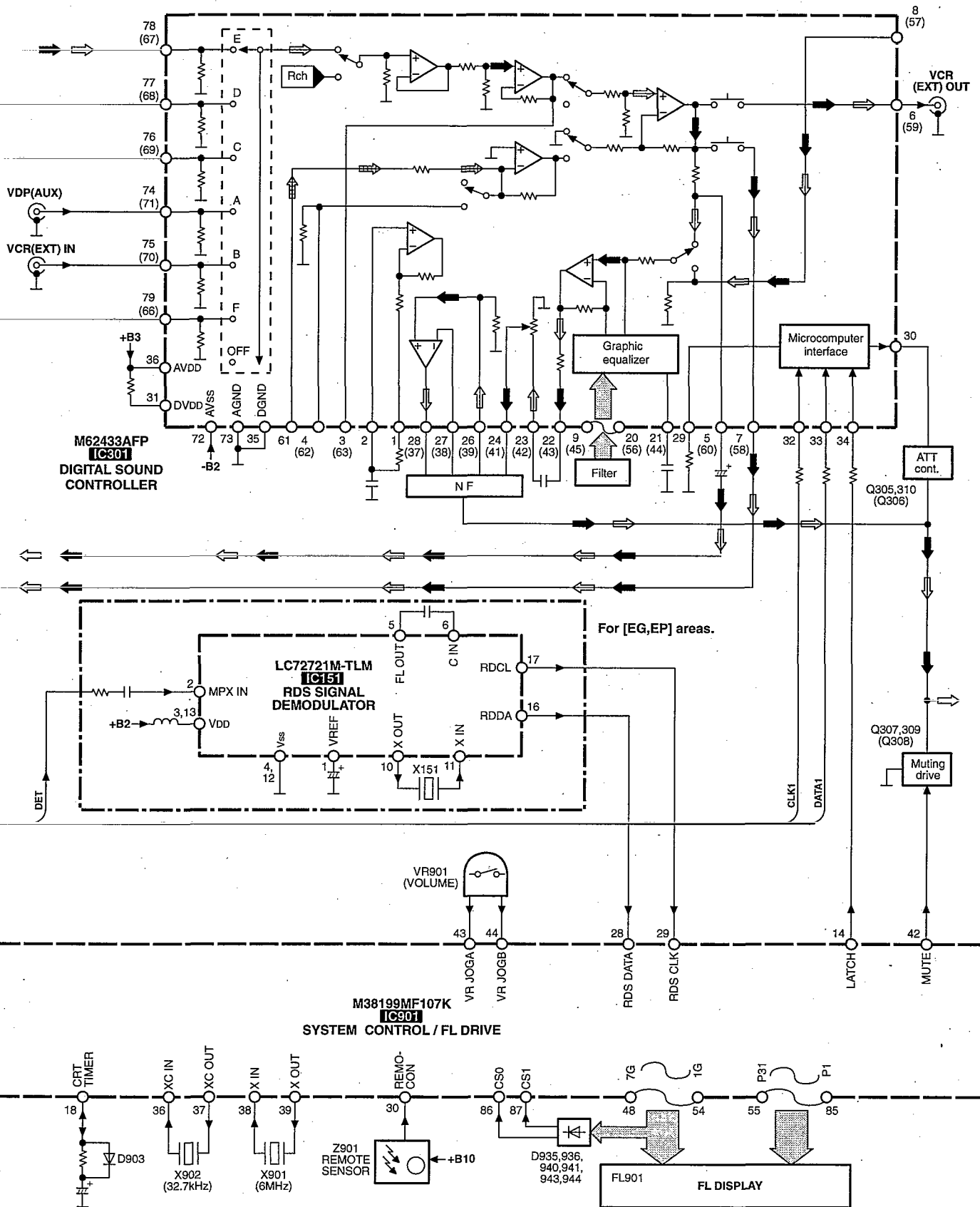

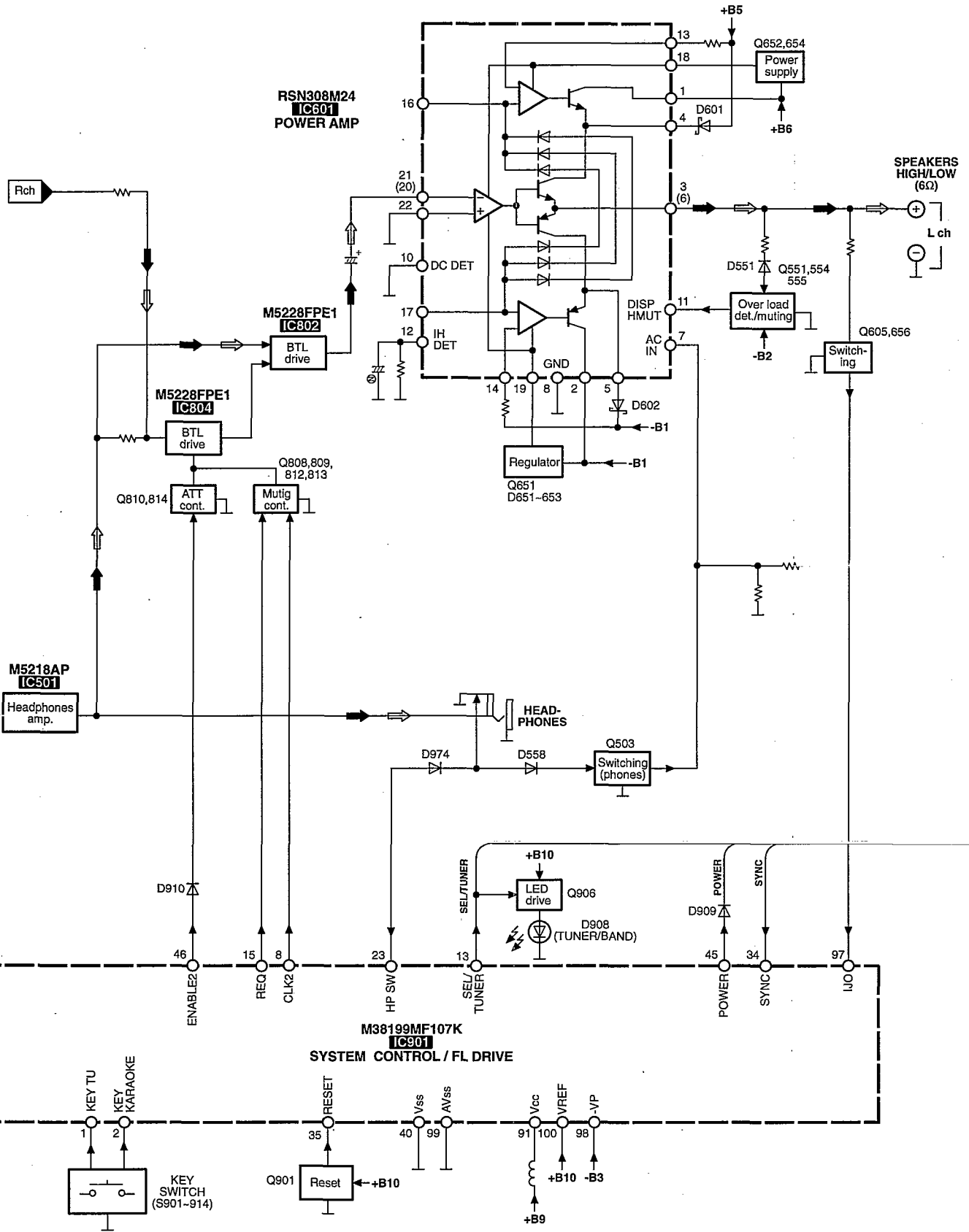

Notes
 1) : FM signal : FM OSC signal
 : AM signal : AM OSC signal
 : MIC signal
 2) () Indicates pin No. of right channel.

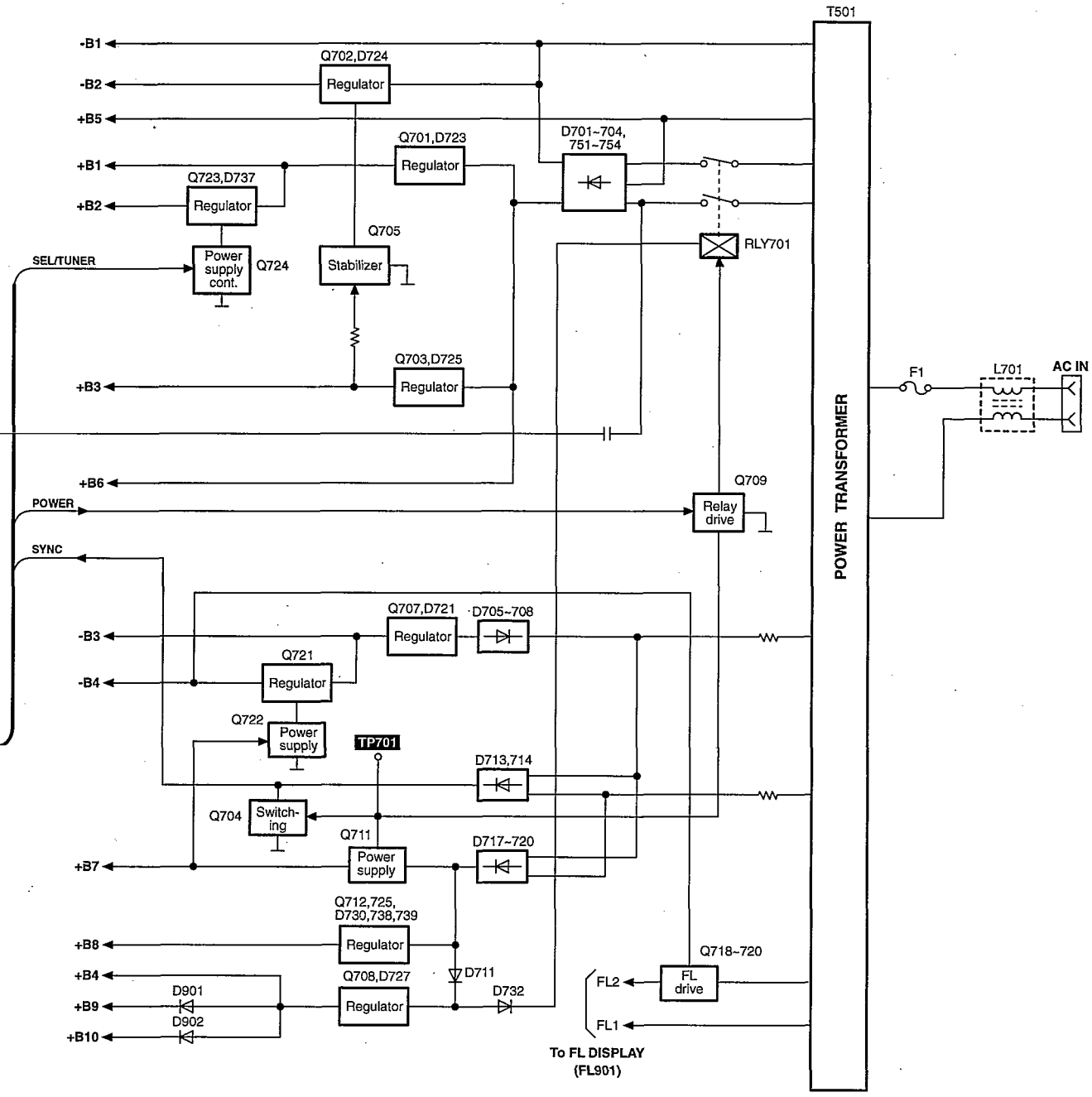

Replacement Parts List

Notes: *Important safety notice:

Components identified by Δ mark have special characteristics important for safety.

Furthermore, special parts which have purposes of fire-retardant (resistors), high-quality sound (capacitors), low-noise (resistors), etc. are used.

When replacing any of components, be sure to use only manufacturer's specified parts shown in the parts list.

*All parts are supplied by MESA.

Ref. No.	Part No.	Part Name & Description	Pcs	Remarks
1	RKM0202E-H	CABINET	1	
2	RHD30007-K1	SCREW	4	
3	XTBS3+10JFZ1	SCREW	1	
4	RGW0183-H	KNOB, VOLUME	1	
5	RKA0011-3	FOOT	4	
5-1	SHG1645	RUBBER	1	
6	RKQ0089-2	PCB SPACER	6	
7	RMN0203	PCB HOLDER 1	1	
8	RFKGAEH500EH	FRONT PANEL ASS'Y	1	(E, EB)
8	RFKGAEH500EG	FRONT PANEL ASS'Y	1	(EG, EP)
9	RMN0427	CABLE HOLDER	1	
10	XTBS3+8JFZ1	SCREW	2	
11	RMN0426	FL HOLDER	1	
12	RMN0429	PCB HOLDER 2	1	
13	RMN0437	PCB HOLDER 3	1	
14	REZ1088	FLAT CABLE ASS'Y	1	
15	REZ0983	FLAT CABLE ASS'Y	1	
16	REZ1076	WIRE ASS'Y	1	
17	RLBT4001-D	FERRITE CORE (5P)	1	
18	REX0852	WIRE ASS'Y	1	
19	RGK0894-N	ORNAMENT	1	
20	XTW3+15T	SCREW	4	
21	XTB3+8JFZ	SCREW	6	
22	RHD26016	SCREW	1	
23	RHN90001	NUT	1	
24	RKW0506B-Q	FL PANEL	1	
25	XTB3+10JFZ	SCREW	9	
26	XTB3+20JFZ	SCREW	5	
27	XTBS26+8J	SCREW	5	
A1	RAK-CH426WH	REMOTE CONTROL TRANSMITTER	1	
A1-1	RKK0080-K	BATTERY COVER	1	
A2	REE0499	SPEAKER CORD	2	
A3	REE0853	SPEAKER CORD	2	
A4	RJA0019-X	AC POWER CORD	1	(E, EG, EP)
A4	RJA0053-1X	AC POWER CORD	1	(EB)
A5	RQA0117	GUARANTY CORD	1	(E, EB, EG)
A6	RQT4299-E	OPERATION INSTRUCTIONS	1	(E) <IA>
A6	RQT4300-D	OPERATION INSTRUCTIONS	1	(EG) <IB>
A6	RQT4301-H	OPERATION INSTRUCTIONS	1	(EG) <IC>
A6	RQT4302-B	OPERATION INSTRUCTIONS	1	(EB, EP) <ID>
A6	RQT4303-R	OPERATION INSTRUCTIONS	1	(EP) <IE>
A7	RSA0007	FM INDOOR ANTENNA	1	
A8	RSA0022-J	AM LOOP ANTENNA	1	
A9	RQCA0597	QUICK REFERENCE GUIDE	1	(EB)
A10	SJP9009	DIN ADAPTOR	1	(EB)
A11	RQCBD169	SERVICE CENTER LIST	1	(E, EB, EG)
C101	ECBT1C103NS5	16V 0.01U	1	
C102	ECEA1CKA101B	16V 100U	1	
C103	ECBT1C103NS5	16V 0.01U	1	
C104, 05	ECBT1H102KB5	50V 1000P	2	
C106	ECBT1C103NS5	16V 0.01U	1	
C107	ECBT1H473ZF5	50V 0.047U	1	
C108	ECBT1H8R2KC5	50V 8.2P	1	
C109	ECBT1H102KB5	50V 1000P	1	
C110	ECBT1C103NS5	16V 0.01U	1	
C111	ECEA1EKA4R7B	25V 4.7U	1	
C112	ECBT1C103NS5	16V 0.01U	1	
C113	ECBT1H102KB5	50V 1000P	1	
C114	RCE1HKA3R3BG	50V 3.3U	1	
C115	ECEA1EKA4R7B	25V 4.7U	1	
C116	ECFR1C333KR	16V 0.033U	1	
C117, 18	ECFR1C183KR	16V 0.018U	2	
C119	ECQP1391JZ3	100V 390P	1	
C120	RCE1CKA100BG	16V 10U	1	
C121	RCE1HKAR47BG	50V 0.47U	1	
C122, 23	ECEA1HKA010B	50V 1U	2	
C124	ECBT1H101KB5	50V 100P	1	
C125	ECEA1CKA220B	16V 22U	1	
C126	ECBT1H473ZF5	50V 0.047U	1	
C127	ECEA1CKA220B	16V 22U	1	
C129, 30	ECEA0JKA101B	6.3V 100U	2	
C131	ECBT1H101KB5	50V 100P	1	

Ref. No.	Part No.	Part Name & Description	Pcs	Remarks
C132	ECBT1H102KB5	50V 1000P	1	
C133, 34	ECBT1H270JU5	50V 27P	2	
C136	ECBT1H102KB5	50V 1000P	1	
C137	ECFR1E472KR	25V 4700P	1	
C138	ECBT1C103KSS	16V 0.01U	2	
C139	ECFR1E472KR	25V 4700P	1	
C141, 42	ECEA1HKA010B	50V 1U	2	
C143, 44	ECBT1C472KR5	16V 4700P	2	
C147	ECBT1H102KB5	50V 1000P	1	
C148	ECBT1C103NSS	16V 0.01U	1	
C149	ECBT1H104ZF5	50V 0.1U	1	
C151	RCE1CKA100BG	16V 10U	1	(EG, EP)
C152	ECBT1H331KB5	50V 330P	1	(EG, EP)
C154	ECBT1H561KB5	50V 560P	1	(EG, EP)
C155	ECBT1H102KB5	50V 1000P	1	(EG, EP)
C156, 57	ECBT1H470J5	50V 47P	2	(EG, EP)
C158, 59	ECEA0JKA470B	6.3V 47U	2	(EG, EP)
C160	ECBT1H102KB5	50V 1000P	1	(EG, EP)
C201, 02	ECBT1H180J5	50V 18P	2	
C219-26	ECBT1H101KB5	50V 100P	8	
C229-34	ECBT1H101KB5	50V 100P	6	
C235	ECBT1H104ZF5	50V 0.1U	1	
C236, 37	ECBT1H102KB5	50V 1000P	2	
C301	ECBT1H102KB5	50V 1000P	1	
C302, 03	ECBT1H561KB5	50V 560P	2	
C309	ECEA1HKAR22B	50V 0.22U	1	
C310	ECFR1C823MR	16V 0.082U	1	
C312	ECFR1C823MR	16V 0.082U	1	
C313	ECFR1C103KR	16V 0.01U	1	
C315	ECFR1C223KR	16V 0.022U	1	
C316	ECBT1C332KR5	16V 3300P	1	
C318	ECBT1C682KR5	16V 6800P	1	
C319	ECBT1H102KB5	50V 1000P	1	
C320	ECBT1H561KB5	50V 680P	1	
C321	ECBT1C332KR5	16V 3300P	1	
C322	ECQV1H154JM3	50V 0.15U	1	
C324	RCE1CKA100BG	16V 10U	1	
C325	ECQV1H154JM3	50V 0.15U	1	
C326	ECBT1H102KB5	50V 1000P	1	
C327	ECBT1H471KB5	50V 470P	1	
C328	RCE1CKA470BG	16V 47U	1	
C329	ECEA1CKA220B	16V 22U	1	
C330	ECBT1H681KB5	50V 680P	1	
C331	ECBT1H104ZF5	50V 0.1U	1	
C332-34	ECBT1H470J5	50V 47P	3	
C336	ECBT1H104ZF5	50V 0.1U	1	
C337	RCE1CKA470BG	16V 47U	1	
C338	ECBT1H471KB5	50V 470P	1	
C339	ECBT1H102KB5	50V 1000P	1	
C340	ECQV1H154JM3	50V 0.15U	1	
C341	RCE1CKA100BG	16V 10U	1	
C342	ECQV1H154JM3	50V 0.15U	1	
C343	ECEA1CKA220B	16V 22U	1	
C344	ECBT1C332KR5	16V 3300P	1	
C346	ECBT1H102KB5	50V 1000P	1	
C347	ECBT1C682KR5	16V 6800P	1	
C349	ECBT1C332KR5	16V 3300P	1	
C350	ECFR1C223KR	16V 0.022U	1	
C352	ECFR1C103KR	16V 0.01U	1	
C353	ECFR1C823MR	16V 0.082U	1	
C355	ECFR1C823MR	16V 0.082U	1	
C356	ECEA1HKAR22B	50V 0.22U	1	
C357, 58	ECQV1H104JM3	50V 0.1U	2	
C359	RCE1HKA3R3BG	50V 3.3U	1	
C360	RCE1HKA4R7BG	50V 4.7U	1	
C364	ECBT1C152KR5	16V 1500P	1	
C365	ECQV1H154JM3	50V 0.15U	1	
C372	ECBT1H104ZF5	50V 0.1U	1	
C385, 86	RCE1CKA100BG	16V 10U	2	
C395, 96	ECBT1H473ZF5	50V 0.047U	2	
C501-06	ECBT1H101KB5	50V 100P	6	
C507, 08	RCE1CKA100BG	16V 10U	2	
C509-12	ECBT1E103ZF5	25V 0.01U	4	
C515	ECEA1CKA330B	16V 33U	1	
C550	ECBT1E103ZF5	25V 0.01U	1	

Ref.No.	Part No.	Part Name & Description	Pcs	Remarks	Ref.No.	Part No.	Part Name & Description	Pcs	Remarks
C551	ECEA1HKA2R2B	50V 2.2U	1		C913	RCE1CKA100BG	16V 10U	1	
C552	ECBT1E103ZF5	25V 0.01U	1		C914	ECEA1HKA2R2B	50V 2.2U	1	
C553	ECEA1HKAR68B	50V 0.68U	1		C915	ECBT1E103ZF5	25V 0.01U	1	
C554	ECA1AM221B	10V 220U	1		C916	ECA0JKF101B	6.3V 100U	1	
C604,05	RCE1CKA100BG	16V 10U	2		C917	ECBT1E103ZF5	25V 0.01U	1	
C607,08	ECBT1C122KR5	16V 1200P	2		C918	ECEA0JKA221B	6.3V 220U	1	
C613,14	ECBT1H150JCS	50V 15P	2		C919,20	ECEA1HKS2R2B	50V 2.2U	2	
C615	ECEA2AUD10B	100V 1U	1		C921	ECBT1H102KB5	50V 1000P	1	
C616	ECA1JM330B	63V 33U	1		C922	ECEA1VKA330B	35V 33U	1	
C617	ECEA1HKNR47B	50V 0.47U	1		C1101,02	ECBT1H473ZF5	50V 0.047U	2	
C618	ECA1HM101B	50V 100U	1		C1103-06	ECBT1H102KB5	50V 1000P	4	
C620,21	ECQV1H473JW3	50V 0.047U	2		C1113,14	ECBT1H473ZF5	50V 0.047U	2	
C631,32	ECBT1H102KB5	50V 1000P	2						
C633	ECBT1C103KS5	16V 0.01U	1		CF201	RLFFETMCD01L	CERAMIC FILTER	1	
C655	ECEA2AU3R3B	100V 3.3U	1		CF202	RLFFETMGD01L	CERAMIC FILTER	1	
C656	ECBT1E103ZF5	25V 0.01U	1						
C657	ECBT1H104ZF5	50V 0.1U	1		CN101B,2B	RJU100W07	CONNECTOR (7P)	2	
△ C701,02	ECA1VHG472E	35V 4700U	2		CN201	RJU057W010	CONNECTOR (10P)	1	
△ C703,04	ECA1VHG332E	35V 3300U	2		CN203	RJU057W012	CONNECTOR (12P)	1	
C705	RCE1CKA100BG	16V 10U	1		CN601	SJT30943-V	CONNECTOR (9P)	1	
C706	RCE1VKA100BG	35V 10U	1		CN701-09	RJS1A1101T1	CONNECTOR (1P)	9	
C707	ECBT1E103ZF5	25V 0.01U	1		CN711-13	RJS1A1101T1	CONNECTOR (1P)	3	
C708	RCE1CKA100BG	16V 10U	1		CN715	RJU057W012	CONNECTOR (12P)	1	
C709	ECBT1H104ZF5	50V 0.1U	1		CN721	SJT30943-V	CONNECTOR (9P)	1	
C710	ECBT1E103ZF5	25V 0.01U	1		CN722	SJT30443-V	CONNECTOR (4P)	1	
C711	RCE1EM471B	25V 470U	1		CN802	RJU057W008	CONNECTOR (8P)	1	
C714	ECBT1H102KB5	50V 1000P	1		CN803	RJU057W007	CONNECTOR (7P)	1	
△ C715	ECA1EM472E	25V 4700U	1		CN904	RJS4T7ZA	CONNECTOR (4P)	1	
C717	ECEA1CKA330B	16V 33U	1						
C718	RCE1AKA101BG	10V 100U	1		CP101B,2B	RJT100W07	CONNECTOR (7P)	2	
C719,20	ECBT1E103ZF5	25V 0.01U	2		CP201	RJT057W010-1	CONNECTOR (10P)	1	
C721	RCE1AKA101BG	10V 100U	1		CP203	RJT057W012-1	CONNECTOR (12P)	1	
C723	ECBT1E103ZF5	25V 0.01U	1		CP715	RJT057W012-1	CONNECTOR (12P)	1	
C725	RCE1CKA100BG	16V 10U	1		CP802	RJT057W008-1	CONNECTOR (8P)	1	
C726	ECBT1E103ZF5	25V 0.01U	1		CP803	RJT057W007-1	CONNECTOR (7P)	1	
C731	ECBT1H102KB5	50V 1000P	1						
C732	ECBT1E223ZF5	25V 0.022U	1		△ D101	MA4051MTA	DIODE	1	
C733	ECBT1E103ZF5	25V 0.01U	1		D151	MA4051MTA	DIODE	1	(EG, EP)
C734	RCE1CKA100BG	16V 10U	1		D331	MA4051LTA	DIODE	1	
△ C736	ECA1EM101B	25V 100U	1		△ D515	MA4140MTA	DIODE	1	
△ C737,38	ECA1HM101B	50V 100U	2		D551,52	MA165	DIODE	2	
△ C739	ECA1JM101B	63V 100U	1		D555	MA4100MTA	DIODE	1	
C740	RCE1CKA100BG	16V 10U	1		D558	MA165	DIODE	1	
C741	ECBT1H104ZF5	50V 0.1U	1		D601,02	SB36DL6508	DIODE	2	
C751,52	ECA1AM471B	16V 470U	2		△ D651	MA4180LTA	DIODE	1	
C753	ECBT1H101KB5	50V 100P	1		△ D652,53	MA4140MTA	DIODE	2	
C761	ECQE1104KF3	100 0.1U	1		D657,58	MA165	DIODE	2	
C810	ECBT1E103ZF5	25V 0.01U	1		△ D701-04	1N5402BF	DIODE	4	
C819	ECBT1E103ZF5	25V 0.01U	1		△ D705-08	RL1N4003N02	DIODE	4	
C822,23	ECBT1H101KB5	50V 100P	2		D709	MA165	DIODE	1	
C838,39	ECBT1H101KB5	50V 100P	2		D710	MA4051MTA	DIODE	1	
C849,50	RCE1CKA100BG	16V 10U	2		D711	RL1N4003N02	DIODE	1	
C853	ECQV1H473JW3	50V 0.047U	1		△ D713,14	MA185TA	DIODE	2	
C854	ECQV1H683JW3	50V 0.068U	1		D715	MA165	DIODE	1	
C855	ECQV1H473JW3	50V 0.047U	1		△ D717-20	RL1N4003N02	DIODE	4	
C856	ECQV1H683JW3	50V 0.068U	1		△ D721	MA4300MTA	DIODE	1	
C859,60	ECBT1H101KB5	50V 100P	2		△ D723	MA4150M	DIODE	1	
C875	ECQV1H823JW3	50V 0.082U	1		△ D725	MA4082LTA	DIODE	1	
C876	ECEA1CKA330B	16V 33U	1		△ D727	MA4062-H	DIODE	1	
C879	ECFR1C683KR	16V 0.068U	1		△ D730	MA4100MTA	DIODE	1	
C880	ECFR1C333KR	16V 0.033U	1		D732-36	MA165	DIODE	5	
C881	ECQV1H154JW3	50V 0.15U	1		△ D737	MA4082LTA	DIODE	1	
C884	ECQV1H104JW3	50V 0.1U	1		D738,39	MA165	DIODE	2	
C885	ECBT1C472KR5	16V 4700P	1		△ D751,52	1N5402BF	DIODE	2	
C886	ECBT1H101KB5	50V 100P	1		△ D753-55	RL1N4003N02	DIODE	3	
C890	ECEATAKA220B	10V 22U	1		D803-05	MA165	DIODE	3	
C891,92	RCE1AKA470BG	10V 47U	2		D901,02	1SS291TA	DIODE	2	
C901	ECBT1H104ZF5	50V 0.1U	1		D903,04	MA165	DIODE	2	
C902	ECA0JM102	6.3V 1000U	1		D905	1SS291TA	DIODE	1	
C903,04	ECBT1E103ZF5	25V 0.01U	2		D906,07	MA165	DIODE	2	
C905-08	ECBT1H471KB5	50V 470P	4		D908	LNJ301MPLJAD	LED	1	
C909	ECBT1H102KB5	50V 1000P	1		D909,10	MA165	DIODE	2	
C910	ECBT1H150JCS	50V 15P	1		D933	MA165TA	DIODE	1	(EG, EP)
C911	ECBT1H180J5	50V 18P	1		D934	MA165	DIODE	1	
C912	ECBT1H104ZF5	50V 0.1U	1		D936	MA165	DIODE	1	

Ref.No.	Part No.	Part Name & Description	Pcs	Remarks
D943, 44	MA165	DIODE	2	
D971, 72	MA165	DIODE	2	
△ D973	MA4039MTA	DIODE	1	
D974	MA165	DIODE	1	
E601	SNE1004-2	EARTH TERMINAL	1	
E603	SNE1004-2	EARTH TERMINAL	1	
△ F1	XBA2C12TBO	FUSE, T1. 25A	1	
FC1, C2	EYF52BC	FUSE HOLDER	2	
FL901	RSL0251-F	DISPLAY TUBE	1	
IC101	LA1833MN-TLM	IC	1	
IC102	LC72131MDTLM	IC	1	
IC151	LC72721M-TLM	IC	1	(EG, EP)
IC301	M62433AFP	IC	1	
IC501	M5218AP	IC	1	
△ IC601	RSN308M24	IC	1	
IC802	M5228FPE1	IC	1	
IC804	M5228FPE1	IC	1	
IC901	M38199MF107K	IC	1	
JK101	RJHS210W	ANTENNA	1	
JK201	RJT065K19	SYSTEM	1	
JK203	SJF3068-7N	VCR IN	1	
JK204	SJF3069-5N	VDP/VCR OUT	1	
JK501	RJRO054B	SPEAKERS	1	
JK503	RJRO054C	SPEAKERS	1	
△ JK701	SJS9236	AC INLET	1	
JK903	RJJ37TNO1-C	HEADPHONES	1	
L101, 02	ELESNR68MA	COIL	2	
L103	ELETR47MA9	COIL	1	
L151, 52	ELEXT101KA9	COIL	2	(EG, EP)
L601, 02	RLQYR73MW1-0	COIL	2	
△ L701	RLQZ271M-K	COIL	1	
L901	RLQA100JT-Y	COIL	1	
P1	RPF0139	POLYETHYLENE COVER	1	
P2	RPG3514	PACKING CASE (SH/SL-EH500)	1	
P2	RPG3515	PACKING CASE (RS-EH600)	1	
P2	RPG3517	PACKING CASE (SA-EH500)	1	
P3	RPG3859	PACKING CASE (SYSTEM)	1	(E)
P3	RPG3860	PACKING CASE (SYSTEM)	1	(EP)
P3	RPG3941	PACKING CASE (SYSTEM)	1	(EG)
P3	RPG3942	PACKING CASE (SYSTEM)	1	(EB)
P4	RPN1037	PAD (RS-EH600)	1	
P4	RPN1038	PAD (SH/SL-EH500)	1	
P4	RPN1117	PAD (SA-EH500)	1	
P5	RPQ0769	SPACER	1	
P6	RPQ0770	SPACER	1	
P7	SPP740	SHEET	1	
Q101, 02	2SC2787L	TRANSISTOR	2	
Q106	UN4111	TRANSISTOR	1	
Q110	2SC3311AR	TRANSISTOR	1	
Q305, 06	2SD1450STA	TRANSISTOR	2	
Q307, 08	2SD2144STA	TRANSISTOR	2	
Q309, 10	UN4115TA	TRANSISTOR	2	
Q503	2SD1450STA	TRANSISTOR	1	
Q551	2SA1995RSTA	TRANSISTOR	1	
Q554	2SA1995RSTA	TRANSISTOR	1	
Q555	2SD2144STA	TRANSISTOR	1	
Q605	2SC5398RSTA	TRANSISTOR	1	
△ Q651	2SB1238QRTV2	TRANSISTOR	1	
Q652	2SD1859QRTV2	TRANSISTOR	1	
Q654	2SD1859QRTV2	TRANSISTOR	1	
Q656	2SC5398RSTA	TRANSISTOR	1	
△ Q701	2SD2374PQAU	TRANSISTOR	1	
△ Q702	2SB1548PQAU	TRANSISTOR	1	
△ Q703	2SD2374PQAU	TRANSISTOR	1	
Q704	UN4211TA	TRANSISTOR	1	
Q705	2SA1995RSTA	TRANSISTOR	1	

Ref.No.	Part No.	Part Name & Description	Pcs	Remarks
△ Q707	2SB621AQRSTA	TRANSISTOR	1	
△ Q708	2SD2137PQTA	TRANSISTOR	1	
Q709	2SD2144STA	TRANSISTOR	1	
Q711	2SB1417PQTA	TRANSISTOR	1	
△ Q712	2SB1548PQAU	TRANSISTOR	1	
Q718	UN4111	TRANSISTOR	1	
Q719, 20	2SD1450STA	TRANSISTOR	2	
Q721	2SC3311AIRTA	TRANSISTOR	1	
Q722	2SA1309AIRTA	TRANSISTOR	1	
△ Q723	2SC3940AQSTA	TRANSISTOR	1	
Q724	UN4211TA	TRANSISTOR	1	
△ Q725	2SC5398RSTA	TRANSISTOR	1	
Q808-10	2SD1450STA	TRANSISTOR	3	
Q812, 13	UN4115TA	TRANSISTOR	2	
Q814	UN4211TA	TRANSISTOR	1	
Q901	UN4214TA	TRANSISTOR	1	
Q902-04	2SC3311AIRTA	TRANSISTOR	3	
Q906	UN411FTA	TRANSISTOR	1	
R102	ERDS2FJ472	1/4W 4.7K	1	
R103	ERDS2FJ101	1/4W 100	1	
R104	ERDS2FJ103	1/4W 10K	1	
R105	ERDS2TJ471T	1/4W 470	1	
R106	ERDS2FJ474	1/4W 470K	1	
R107	ERDS2TJ331T	1/4W 330	1	
R108	ERDS2FJ474	1/4W 470K	1	
R109	ERDS2TJ331T	1/4W 330	1	
R110	ERDS2FJ102	1/4W 1K	1	
R111	ERDS2TJ391T	1/4W 390	1	
R112	ERDS2FJ104	1/4W 100K	1	
R113	ERDS2FJ103	1/4W 10K	1	
R114	ERDS2FJ562	1/4W 5.6K	1	
R115	ERDS2TJ561T	1/4W 560	1	
R116	ERDS2FJ102	1/4W 1K	1	
R117	ERDS2TJ683T	1/4W 68K	1	
R118	ERDS2FJ472	1/4W 4.7K	1	
R119	ERDS2TJ333T	1/4W 33K	1	
R120	ERDS2TJ473T	1/4W 47K	1	
R121	ERDS2TJ223T	1/4W 22K	1	
R122	ERDS2FJ272	1/4W 2.7K	1	
R123	ERDS2TJ683T	1/4W 68K	1	
R124	ERDS2TJ271T	1/4W 270	1	
R125, 26	ERDS2TJ152T	1/4W 1.5K	2	
R127	ERDS2TJ471T	1/4W 470	1	
R128	ERDS2TJ820T	1/4W 82	1	
R129	ERDS2TJ273T	1/4W 27K	1	
R130	ERDS2FJ103	1/4W 10K	1	
R131	ERDS2FJ680	1/4W 68	1	
R132	ERDS2FJ103	1/4W 10K	1	
R133-37	ERDS2FJ102	1/4W 1K	5	
R138	ERDS2FJ103	1/4W 10K	1	
R139	ERDS2TJ332T	1/4W 3.3K	1	
R140	ERDS2FJ472	1/4W 4.7K	1	
R141, 42	ERDS2FJ102	1/4W 1K	2	
R143	ERDS2TJ223T	1/4W 22K	1	
R145, 46	ERDS2FJ104	1/4W 100K	2	
R151, 52	ERDS2TJ102T	1/4W 1K	2	(EG, EP)
R153, 54	ERDS2TJ104T	1/4W 100K	2	(EG, EP)
R155	ERDS2TJ121T	1/4W 120	1	(EG, EP)
R158, 59	ERDS2TJ102T	1/4W 1K	2	(EG, EP)
R201, 02	ERDS2FJ752	1/4W 7.5K	2	
R217, 18	ERDS2FJ562	1/4W 5.6K	2	
R221, 22	ERDS2FJ752	1/4W 7.5K	2	
R223, 24	ERDS2FJ562	1/4W 5.6K	2	
R225, 26	ERDS2FJ104	1/4W 100K	2	
R227, 28	ERDS2FJ222	1/4W 2.2K	2	
R229, 30	ERDS2FJ102	1/4W 1K	2	
R231, 32	ERDS2FJ103	1/4W 10K	2	
R233, 34	ERDS2FJ682	1/4W 6.8K	2	
R235, 36	ERDS2FJ102	1/4W 1K	2	
R239-42	ERDS2FJ102	1/4W 1K	4	
R243, 44	ERDS2TJ152T	1/4W 1.5K	2	
R245, 46	ERDS2TJ332T	1/4W 3.3K	2	
R249, 50	ERDS2FJ101	1/4W 100	2	
R251	ERDS2FJ222	1/4W 2.2K	1	

Ref.No.	Part No.	Part Name & Description	Pcs	Remarks	Ref.No.	Part No.	Part Name & Description	Pcs	Remarks
R252	ERDS2FJ103	1/4W 10K	1		R713, 14	ERDS2TJ332T	1/4W 3.3K	2	
R253, 54	ERDS2FJ104	1/4W 100K	2		R715	ERDS2FJ183	1/4W 18K	1	
R255, 56	ERDS2TJ123T	1/4W 12K	2		R717	ERDS2TJ473T	1/4W 47K	1	
R257, 58	ERDS2FJ562	1/4W 5.6K	2		R719	ERDS2TJ332T	1/4W 3.3K	1	
R261, 62	ERDS2FJ1R0	1/4W 1	2		R720	ERDS2FJ272	1/4W 2.7K	1	
R301	ERDS2TJ223T	1/4W 22K	1		△ R721	ERD2FCJ4R7	1/4W 4.7	1	
R302	ERDS2FJ472	1/4W 4.7K	1		△ R722	ERQ16NKW2R2E	1/6W 2.2	1	
R303, 04	ERDS2FJ222	1/4W 2.2K	2		R723	ERDS2FJ562	1/4W 5.6K	1	
R305, 06	ERDS2FJ102	1/4W 1K	2		R724	ERDS2TJ152T	1/4W 1.5K	1	
R307, 08	ERDS2FJ104	1/4W 100K	2		R725	ERDS2TJ100T	1/4W 10	1	
R309, 10	ERDS2FJ102	1/4W 1K	2		R727	ERDS2TJ152T	1/4W 1.5K	1	
R311, 12	ERDS2FJ104	1/4W 100K	2		R729	ERDS2TJ221T	1/4W 220	1	
R313, 14	ERDS2TJ121T	1/4W 120	2		△ R735	ERQ16NKW2R2E	1/6W 2.2	1	
R315	ERDS2FJ104	1/4W 100K	1		R736	ERDS2FJ102	1/4W 1K	1	
R316	ERDS2FJ222	1/4W 2.2K	1		R737	ERDS2TJ221T	1/4W 220	1	
R317	ERDS2FJ105	1/4W 1M	1		R738	ERDS2FJ392	1/4W 3.9K	1	
R318	ERDS2TJ153T	1/4W 15K	1		R739	ERDS2TJ473T	1/4W 47K	1	
R323	ERDS2FJ272	1/4W 2.7K	1		R748	ERDS2FJ102	1/4W 1K	1	
R324	ERDS2TJ223T	1/4W 22K	1		R749	ERDS2TJ271T	1/4W 270	1	
R325	ERDS2FJ272	1/4W 2.7K	1		R751-54	ERDS2FJ4R7	1/4W 4.7	4	
R326	ERDS2TJ332T	1/4W 3.3K	1		△ R755	ERDS1FJ8R2	1/2W 8.2	1	
R327	ERDS2FJ392	1/4W 3.9K	1		△ R756	ERDS1FJ4R7	1/2W 4.7	1	
R328	ERDS2TJ332T	1/4W 3.3K	1		R757-59	ERDS2FJ103	1/4W 10K	3	
R329	ERDS2FJ103	1/4W 10K	1		R761, 62	ERDS2TJ822T	1/4W 8.2K	2	
R330	ERDS2TJ332T	1/4W 3.3K	1		R763	ERDS2FJ472	1/4W 4.7K	1	
R331	ERDS2FJ102	1/4W 1K	1		R764	ERDS2TJ331T	1/4W 330	1	
R332-34	ERDS2FJ222	1/4W 2.2K	3		△ R765	ERDS1FJ561	1/2W 560	1	
R335, 36	ERDS2TJ333T	1/4W 33K	2		R766	ERDS2FJ102	1/4W 1K	1	
R338	ERDS2FJ392	1/4W 3.9K	1		△ R767	ERD2FCJ4R7	1/4W 4.7	1	
R343	ERDS2TJ334T	1/4W 330K	1		R768	ERDS2FJ101	1/4W 100	1	
R344, 45	ERDS2FJ392	1/4W 3.9K	2		△ R791, 92	RSFMB30KT-L	PROTECTOR	2	
R360	ERDS2TJ223T	1/4W 22K	1		R803, 04	ERDS2TJ153T	1/4W 15K	2	
R364	ERDS2FJ103	1/4W 10K	1		R805	ERDS2TJ433T	1/4W 43K	1	
R365	ERDS2TJ223T	1/4W 22K	1		R806	ERDS2TJ333T	1/4W 33K	1	
R371, 72	ERDS2TJ100T	1/4W 10	2		R807	ERDS2TJ153T	1/4W 15K	1	
R380	ERDS2TJ153T	1/4W 15K	1		R809, 10	ERDS2TJ223T	1/4W 22K	2	
R501, 02	ERDS2FJ102	1/4W 1K	2		R811	ERDS2FJ103	1/4W 10K	1	
R503, 04	ERDS2TJ333T	1/4W 33K	2		R812	ERDS2TJ153T	1/4W 15K	1	
R505, 06	ERDS2FJ103	1/4W 10K	2		R813, 14	ERDS2TJ223T	1/4W 22K	2	
R507, 08	ERDS2TJ332T	1/4W 3.3K	2		R815, 16	ERDS2TJ473T	1/4W 47K	2	
R509-12	ERDS2FJ101	1/4W 100	4		R817	ERDS2TJ332T	1/4W 3.3K	1	
△ R515	ERGS1J102	1W 1K	1		R818	ERDS2TJ153T	1/4W 15K	1	
R551	ERDS2FJ183	1/4W 18K	1		R820	ERDS2TJ274T	1/4W 270K	1	
R552	ERDS2TJ473T	1/4W 47K	1		R821	ERDS2TJ822T	1/4W 8.2K	1	
R555	ERDS2TJ223T	1/4W 22K	1		R824	ERDS2FJ823	1/4W 82K	1	
R556	ERDS2FJ104	1/4W 100K	1		R828	ERDS2FJ823	1/4W 82K	1	
R557	ERDS2FJ103	1/4W 10K	1		R829, 30	ERDS2TJ223T	1/4W 22K	2	
R558	ERDS2FJ102	1/4W 1K	1		R831	ERDS2FJ392	1/4W 3.9K	1	
R559	ERDS2FJ472	1/4W 4.7K	1		R832	ERDS2TJ182T	1/4W 1.8K	1	
R561	ERDS2FJ104	1/4W 100K	1		R833, 34	ERDS2FJ104	1/4W 100K	2	
R562	ERDS2FJ102	1/4W 1K	1		R839, 40	ERDS2FJ102	1/4W 1K	2	
R570	ERDS2TJ335T	1/4W 3.3M	1		R841	ERDS2FJ103	1/4W 10K	1	
R591	ERDS2FJ472	1/4W 4.7K	1		R871, 72	ERDS2FJ105	1/4W 1M	2	
R604, 05	ERDS2FJ682	1/4W 6.8K	2		R876	ERDS2FJ224	1/4W 220K	1	
R619, 20	ERDS2TJ563T	1/4W 56K	2		R877, 78	ERDS2FJ472	1/4W 4.7K	2	
R623	ERDS2TJ684T	1/4W 680K	1		R879	ERDS2FJ562	1/4W 5.6K	1	
R624	ERDS2TJ223T	1/4W 22K	1		R889	ERDS2TJ152T	1/4W 1.5K	1	
R628	ERDS2FJ184	1/4W 18K	1		R893	ERDS2FJ103	1/4W 10K	1	
R629, 30	ERDS2TJ100T	1/4W 10	2		R894	ERDS2TJ153T	1/4W 15K	1	
R631	ERDS2FJ224	1/4W 220K	1		R901	ERDS2TJ821T	1/4W 820	1	
R632	ERDS2TKF5362	1/4W 53.6K	1		R902	ERDS2FJ102	1/4W 1K	1	
R633	ERDS2TKG5622	1/4W 56.2K	1		R903	ERDS2TJ122T	1/4W 1.2K	1	
R637	ERDS2TJ154T	1/4W 150K	1		R904	ERDS2TJ152T	1/4W 1.5K	1	
R638	ERDS2TJ684T	1/4W 680K	1		R905	ERDS2TJ182T	1/4W 1.8K	1	
△ R639-42	ERDS1FJ100	1/2W 10	4		R906	ERDS2FJ222	1/4W 2.2K	1	
△ R647, 48	ERD25FVJ2R2T	1/4W 2.2	2		R907	ERDS2FJ272	1/4W 2.7K	1	
R651	ERDS2FJ272	1/4W 2.7K	1		R908	ERDS2FJ472	1/4W 4.7K	1	
R654	ERDS2FJ272	1/4W 2.7K	1		R909	ERDS2FJ682	1/4W 6.8K	1	
R655, 56	ERDS2FJ183	1/4W 18K	2		R910	ERDS2TJ123T	1/4W 12K	1	
R667	ERDS2TJ331T	1/4W 330	1		R911	ERDS2TJ223T	1/4W 22K	1	
R701, 02	ERDS2TJ273T	1/4W 27K	2		R912	ERDS2TJ821T	1/4W 820	1	
R703, 04	ERDS2FJ101	1/4W 100	2		R919-23	ERDS2FJ103	1/4W 10K	5	
△ R707	ERDS2FJ4R7	1/4W 4.7	1		R924-27	ERDS2FJ102	1/4W 1K	4	
R708	ERDS2FJ472	1/4W 4.7K	1		R929	ERDS2FJ102	1/4W 1K	1	
R712	ERDS2TJ152T	1/4W 1.5K	1		R930	ERDS2FJ101	1/4W 100	1	

■ Cabinet Parts Location

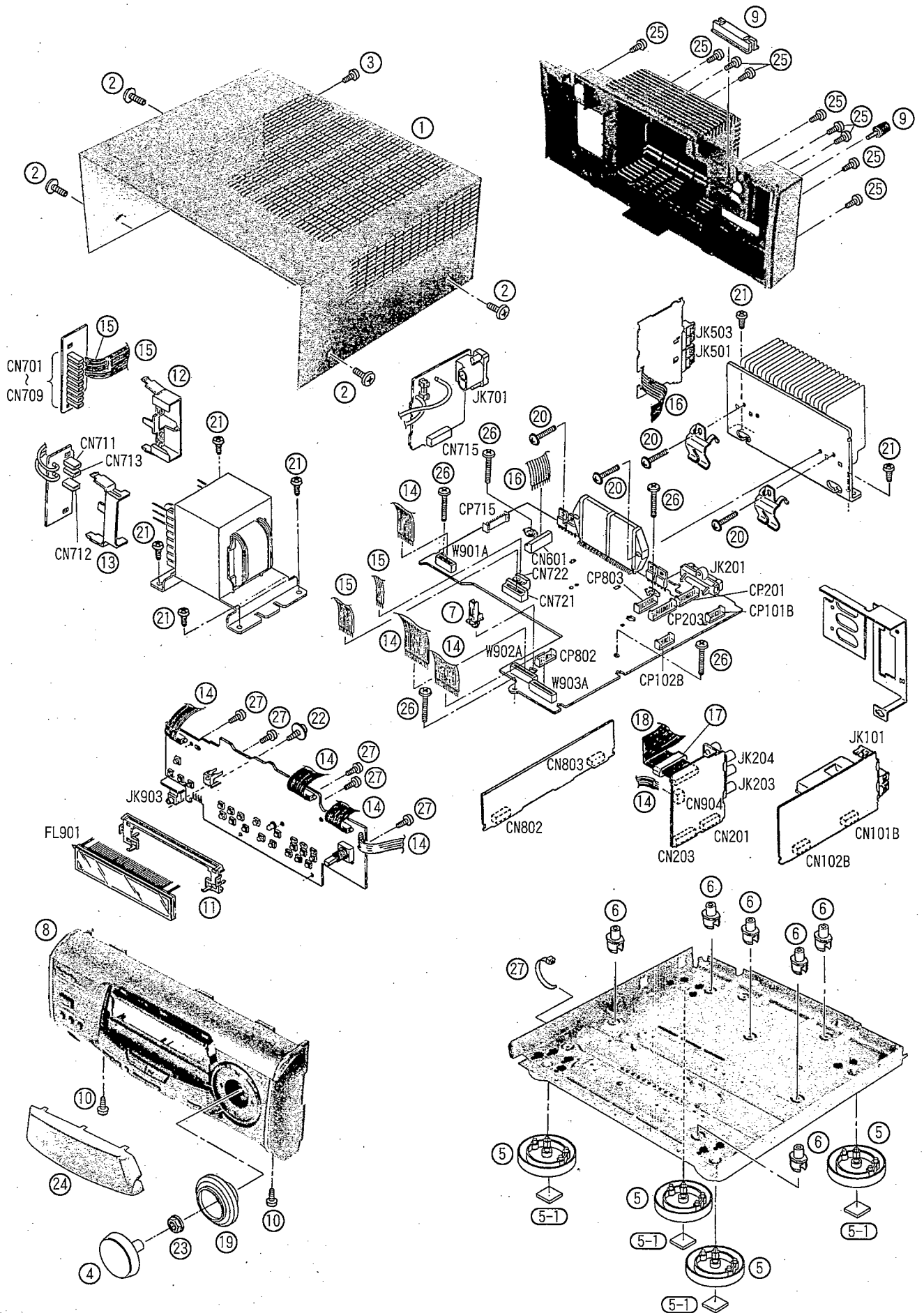

■ Packaging

903

