

Service Manual

Tuner/Amplifier

Tuner/Amplifier SA-EH600

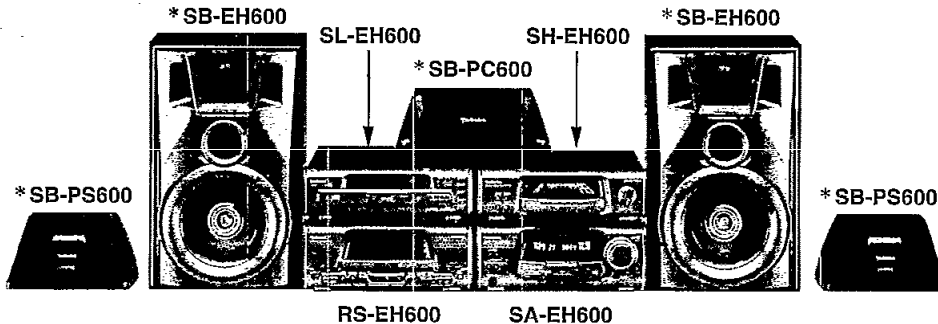

Colour
(H) Gray Type

Areas
(E) Europe
(EB) Great Britain.
(EG) Germany and Italy.
(EP) Russia.

Because of unique interconnecting cables, when a component requires service, send or bring in the entire system.

System	SC-EH600
Sound Processor	SH-EH600
Tuner / Amplifier	SA-EH600
CD Changer	SL-EH600
Cassette Deck	RS-EH600
Front Speakers*	SB-EH600
Center Speaker*	SB-PC600
Surround Speakers*	SB-PS600

* : Made in PAES

Specifications

Amplifier Section

Power output (at HIGH terminal) :	
DIN 1 kHz, THD 1%, both channels driven ;	2 × 70 W(6 Ω)
RMS 1 kHz, THD 10%, both channels driven ;	2 × 100 W(6 Ω)
PRO LOGIC mode (at HIGH terminal) :	
DIN 1 kHz, THD 1%	
MAIN (both channels driven) ;	2 × 50 W(6 Ω)
SURROUND ;	50 W(4 Ω + 4 Ω)
CENTER ;	50 W(8 Ω)
RMS 1 kHz, THD 10%	
MAIN (both channels driven) ;	2 × 70 W(6 Ω)
SURROUND ;	70 W(4 Ω + 4 Ω)
CENTER ;	70 W(8 Ω)
Total harmonic distortion :	
Rated power at 1 kHz ;	1 % (6 Ω)
Half power at 1 kHz ;	0.09 % (6 Ω)
Load impedance :	
MAIN (HIGH/LOW) ;	total impedance 6 Ω
SURROUND ;	4 – 8 Ω
CENTER ;	8 Ω
Input sensitivity/impedance:	
PHONO ;	2.5 mV/47 kΩ
EXTERNAL ;	250 mV/15 kΩ
Output level:	
EXTERNAL RECOUT ;	250 mV/1.5 kΩ
S.WOOFER :	
Center frequency ;	70 Hz
LEVEL (VOL -20 dB)	MID +8 dB
	MAX +12 dB

FM Tuner Section

Frequency range ;	87.50 – 108.00 MHz (0.05 MHz steps)
Sensitivity ;	1.8 μV (IHF usable)
S/N 26 dB ;	1.5 μV
S/N:	
MONO ;	70 dB (75 dB, IHF)
Antenna terminal(s) ;	75 Ω (unbalanced)

AM Tuner Section

Frequency range:	522 – 1611 kHz (9 kHz steps)
	530 – 1620 kHz (10 kHz steps)
Sensitivity (S/N 20 dB) ;	500 μV/m

Timer Section

Clock :	Quartz-lock type
Functions :	Play timer (1 time), Rec timer (1 time), Sleep (120 min, 30 min intervals)
Setting :	1 minute – 23 hours 59 minutes (1 min intervals)

General

Power supply :	
For (E), (EG), (EP) areas ;	AC 230V, 50 Hz
For (EB) area ;	AC 230–240 V, 50 Hz
Power consumption :	205 W
Dimensions :	287 (W) × 118.5 (H) × 343.5 (D) mm
Weight :	5.0 kg

Notes: Specifications are subject to change without notice.
Weight and dimensions are approximate.

⚠ WARNING

This service information is designed for experienced repair technicians only and is not designed for use by the general public. It does not contain warnings or cautions to advise non-technical individuals of potential dangers in attempting to service a product. Products powered by electricity should be serviced or repaired only by experienced professional technicians. Any attempt to service or repair the product or products dealt with in this service information by anyone else could result in serious injury or death.

Technics®

© 1998 Matsushita Electric Industrial Co., Ltd.
All rights reserved. Unauthorized copying
and distribution is a violation of law.

Contents

	Page		Page
Before Repair	2	To Supply Power Source	17
Protection Circuitry	2	To Check Operation	17
Accessories	2	About the Self-Diagnostic Mode	18
Caution for AC Main Lead	3	Schematic Diagram	19 - 34
Location of Controls	4	Printed Circuit Board Diagram	35 - 38
Installation	4	Wiring Connection Diagram	39
Connections	5 - 7	Type Illustration of IC's, Transistors and Diodes	40
Enjoying RDS Broadcasts	8, 9	Terminal Function of IC's	41
Setting the Time	9	Block Diagram	42 - 47
Enjoying Sound with DOLBY PRO LOGIC	10 - 12	Replacement Parts List	48 - 53
Operation Checks and Main Component Replacement Procedures	13 - 16	Cabinet Parts Location	54
		Packaging	55

Before Repair

- (1) Turn off the power supply. Using a 10 Ω , 10 W resistor, connect both ends of power supply capacitors (C701, C702, C703 and C704) in order to discharge the voltage.
- (2) Before turning the power supply on, after completion of repair, slowly apply the primary voltage by using a power supply voltage controller to make sure that the consumed current at 50 Hz in NO SIGNAL mode should be shown below with respect to supply voltage 230 V or 240 V.

Power supply voltage	AC 230 V	AC 240 V
Consumed current 50 Hz	140 ~ 400 mA	140 ~ 400 mA

Protection Circuitry

The protection circuitry may have operated if either of the following conditions is noticed:

- * No sound is heard when the power is switched ON.
- * Sound stops during a performance.

The functions of this circuitry is to prevent circuitry damage if, for example, the positive and negative speaker connection wires are "shorted", or if speaker systems with an impedance less than the indicated rated impedance of this unit are used.

If this occurs, follow the procedure outlined below:

1. Switch OFF the power.
2. Determine the cause of the problem and correct it.
3. Switch ON the power once again.

Note:

When the protection circuitry functions, the unit will not operate unless the power is first switched OFF and then ON again.

Accessories

• AC power supply cord

For (E), (EG), (EP) areas (RJA0019-X) ... 1 pc.

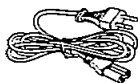

For (EB) area (RJA0053-1X) 1 pc.



• Remote control transmitter

(RAK-CH219WH) 1 pc.

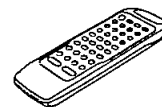

• Batteries

(UM-4, "AAA", R03) 2 pcs.

Note: These are available on sales route.

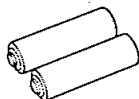

• FM indoor antenna

(RSA0007) 1 pc.

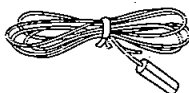

• AM loop antenna

(RSA0022-J) 1 pc.



• Speaker cords

(REE0393) 2 pcs.

(REE0853) 2 pcs.

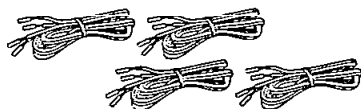

• Antenna plug adaptor (SJP9009)

For (EB) only (SJP9009) 1 pc.



■ Caution for AC Main Lead



("EB" area code model only)

For your safety, please read the following text carefully.

This appliance is supplied with a moulded three pin mains plug for your safety and convenience.

A 5-ampere fuse is fitted in this plug.

Should the fuse need to be replaced please ensure that the replacement fuse has a rating of 5-ampere and that it is approved by ASTA or BSI to BS1362.

Check for the ASTA mark  or the BSI mark  on the body of the fuse.

If the plug contains a removable fuse cover you must ensure that it is refitted when the fuse is replaced.

If you lose the fuse cover the plug must not be used until a replacement cover is obtained.

A replacement fuse cover can be purchased from your local dealer.

CAUTION!

IF THE FITTED MOULDED PLUG IS UNSUITABLE FOR THE SOCKET OUTLET IN YOUR HOME THEN THE FUSE SHOULD BE REMOVED AND THE PLUG CUT OFF AND DISPOSED OF SAFELY.

THERE IS A DANGER OF SEVERE ELECTRICAL SHOCK IF THE CUT OFF PLUG IS INSERTED INTO ANY 13-AMPERE SOCKET.

If a new plug is to be fitted please observe the wiring code as shown below.

If in any doubt please consult a qualified electrician.

IMPORTANT

The wires in this mains lead are coloured in accordance with the following code:

Blue: Neutral, Brown: Live.

As these colours may not correspond with the coloured markings identifying the terminals in your plug, proceed as follows:

The wire which is coloured Blue must be connected to the terminal which is marked with the letter N or coloured Black or Blue.

The wire which is coloured Brown must be connected to the terminal which is marked with the letter L or coloured Brown or Red.

WARNING: DO NOT CONNECT EITHER WIRE TO THE EARTH TERMINAL WHICH IS MARKED WITH THE LETTER E, BY THE EARTH SYMBOL \perp OR COLOURED GREEN OR GREEN/YELLOW.

THIS PLUG IS NOT WATERPROOF—KEEP DRY.

Before use

Remove the connector cover.

How to replace the fuse

The location of the fuse differ according to the type of AC mains plug (figures A and B). Confirm the AC mains plug fitted and follow the instructions below. Illustrations may differ from actual AC mains plug.

1. Open the fuse cover with a screwdriver.

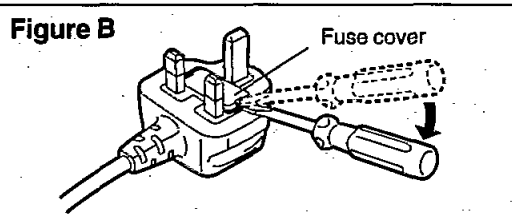
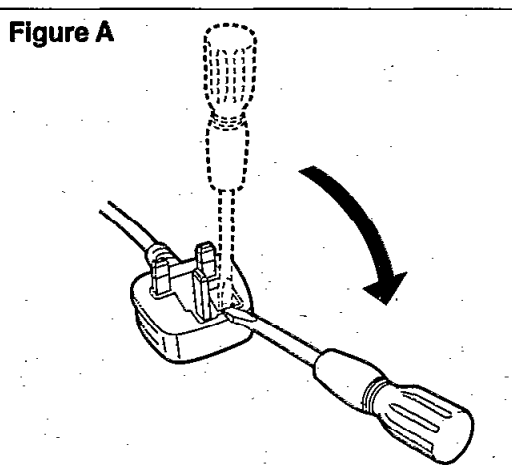

2. Replace the fuse and close or attach the fuse cover.

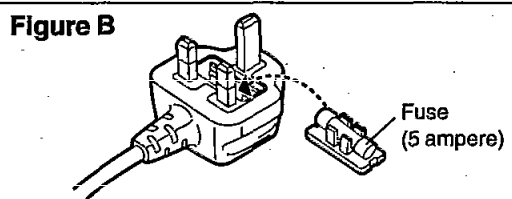
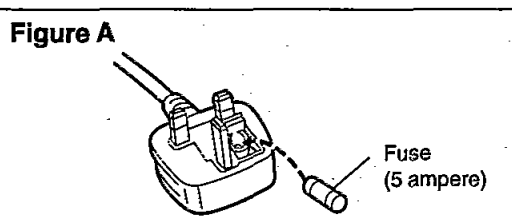

■ Location of Controls

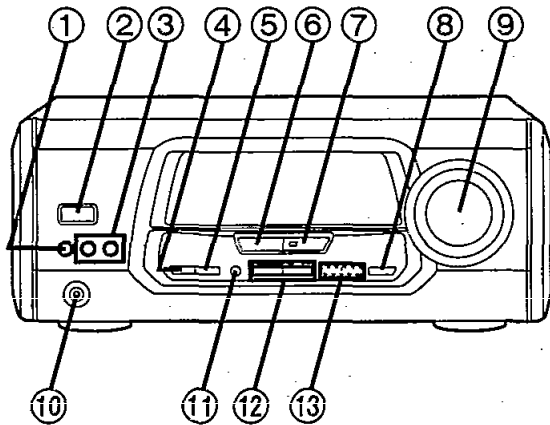

- ① Clock/timer button (CLOCK/TIMER)
- ② Power "STANDBY Ⓞ/ON" switch (POWER, STANDBY Ⓞ/ON)
- ③ Timer on/off buttons (Ⓞ PLAY, Ⓞ REC)
- ④ Tuning mode select button (TUNING MODE)
- ⑤ Set button (SET)
- ⑥ Source input select button (INPUT SELECTOR)
- ⑦ Tuner/band select button and indicator (TUNER/BAND)
- ⑧ Super woofer button (S. WOOFER)
- ⑨ Volume control (VOLUME)
- ⑩ Headphones jack (PHONES)
- ⑪ FM mode select button (FM AUTO/MONO)
- ⑫ Tuning buttons (TUNING, V, Δ)

For (EG) and (EP) areas

- ⑬ RDS display mode select buttons (RDS PS-DISP MODE-PTY)

■ Installation

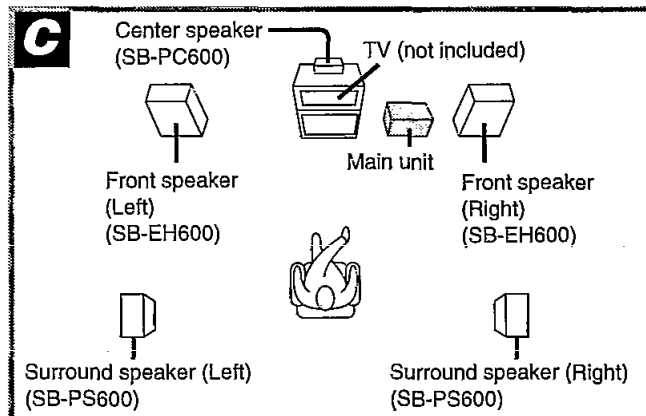
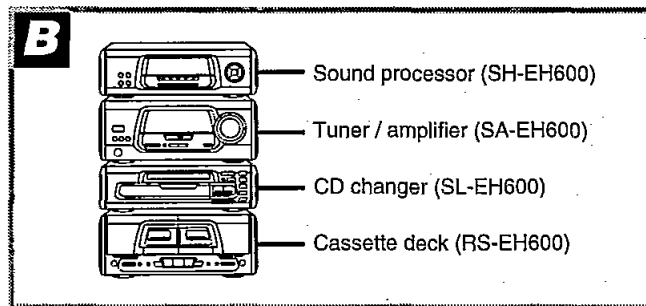
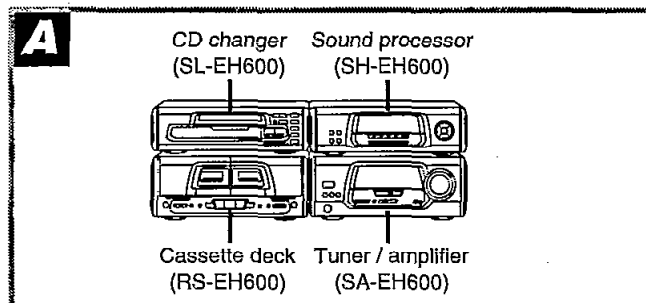

Locating the components

- Side-by-side set-up **A**
- Stacking **B**

Placement of speakers

As well as enjoying normal stereo reproduction with the left and right front speakers, a center speaker and surround speakers can also be connected to the unit in order to enjoy the sound performance of DOLBY PRO LOGIC Systems.

We recommend that surround speakers be placed on the side of or slightly behind the listener, and about one meter higher than ear level.

However the position should be adjusted to your personal preference, because the effect varies to some degree depending upon the type of music and the music source.

Note for front/center speakers

These speakers are made so as to be able to be used in close proximity to the TV, but irregular coloring may result due to how the system is placed. If such distortion occurs, turn off the TV for sometime between 15 and 30 minutes. The demagnetizing function of the TV will eliminate the distortion. If the irregular coloring is still visible, then move the speaker further away from the TV.

Please note that if there is a magnetic object near the TV, irregular coloring may result due to the interaction between the TV and the speakers.

Connections

Connect the AC power supply cord after you have connected all other cables.

To prepare the AM loop antenna wire, FM indoor antenna and speaker cords, twist the vinyl cover tip and pull off.

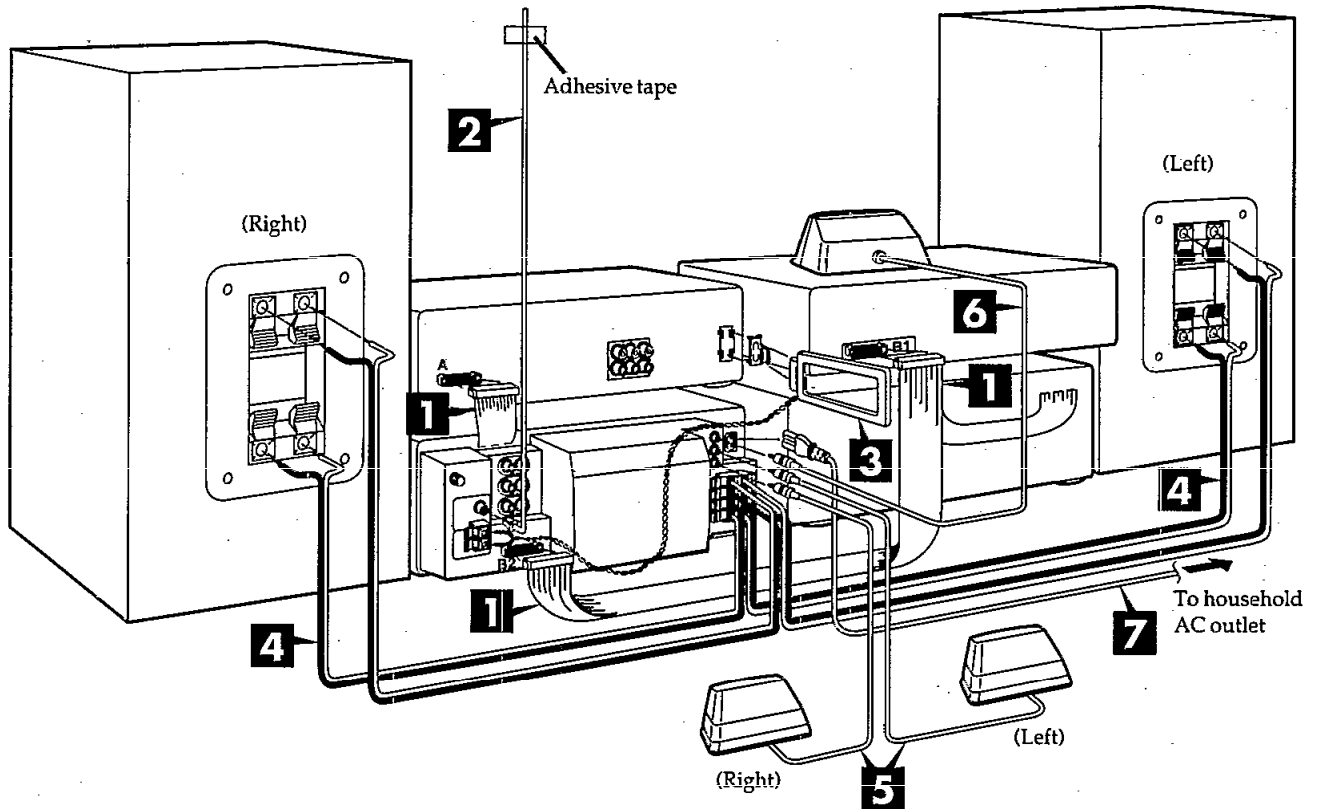
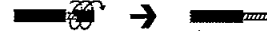

1

To connect cables **To unplug cables**

Connector

White line

3

5 **Attaching to wall**

Slit

140 mm

Screws (not included)

2

FM ANT 75Ω

4 **Tuner/amplifier side**

Gray (+)
Blue (-)
Black (-)

Red (+)

Speaker side

Blue (-)

Gray (+)
Black (-) Red (+)

7 **(Insertion of Connector)**

Appliance inlet

Connector

Approx. 6 mm

1 Connect the flat cables.

1. Connect the shorter flat cable from the tuner/amplifier to terminal A on the sound processor.
2. Connect the longer flat cable from the cassette deck to terminals B1 and B2.

Note

Do not try connecting or disconnecting the flat cables while the power is switched to ON.

After connection:

Keep cables as flat against the back of the unit as possible.

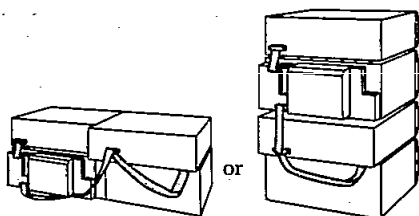
**2 Connect the FM indoor antenna.**

Tape the antenna to a wall or column, in a position where radio signals are received with the least amount of interference.

Note

When you cannot get good reception with this FM indoor antenna, we recommend you install an FM outdoor antenna (not included).

3 Connect the AM loop antenna.

1. Attach the antenna holder to the rear panel of the sound processor.
Then clamp the antenna into the antenna holder.
2. Connect the antenna terminal to the rear panel of the tuner/amplifier.

Note

To minimize noise pickup, bundle the loop antenna cord using tape or the like to keep the flat cables away from the AM loop antenna cord.

4 Connect the right (R) and left (L) front speaker cables.

Connect each end of the speaker cables to the terminal lever of the same color.

Note

- To prevent damage to circuitry, never short-circuit positive (+) and negative (-) speaker wires.
- Be sure to connect only positive (red or gray) wires to positive (+) terminals and negative (black or blue) wires to negative (-) terminals.
- Left and right front speakers are exactly the same.

5 Connect the surround speaker cables.

Check the L (Left) or R (Right) channels indication on the underside of the speakers for correct placement. Place the speakers with the Technics logo facing forward the listening position.

Attaching to wall

- Set speaker onto screws and slide through bracket kink to lock into position.
- The wall or pillar on which the speaker systems are to be attached should be capable of supporting a weight of 5 kilograms.
- Feed wire through slit to fix from center-top of speaker.

6

Connect the center speaker cables.

7

Connect the AC mains lead.

(United Kingdom only)

BE SURE TO READ THE CAUTION FOR AC MAINS LEAD ON PAGE 3 BEFORE PROCEEDING TO STEP 7.

Insertion of Connector

Even when the connector is perfectly inserted, depending on the type of inlet used, the front part of the connector may jut out as shown in the drawing.

However there is no problem using the unit.

Speaker Caution

Use the speakers only with the recommended system. Failure to do so may lead to damage to the amplifier and/or the speaker, and may result in the risk of fire. Consult a qualified service person if damage has occurred or if you experience a sudden change in performance.

When speakers are connected to the LOW and HIGH terminals on the back of the main unit

They are designed to have a combined impedance of 6Ω.

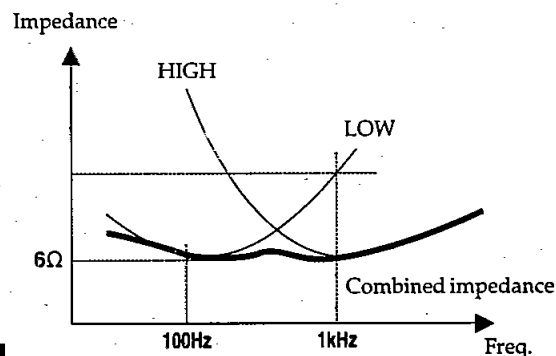
**Note**

Never use speakers other than those supplied. (SB-EH600) For instance, if you connect speakers with an impedance of 6Ω each and plug them into the LOW and HIGH terminals, you will only have a combined impedance of 3Ω

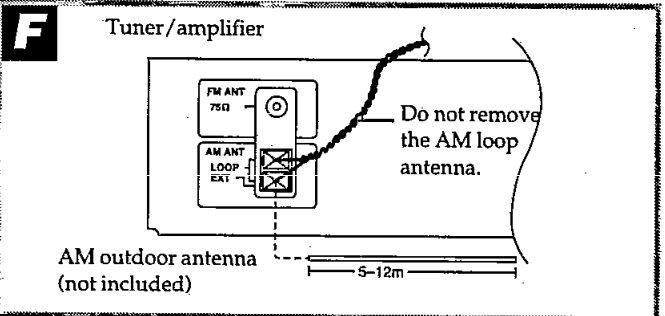
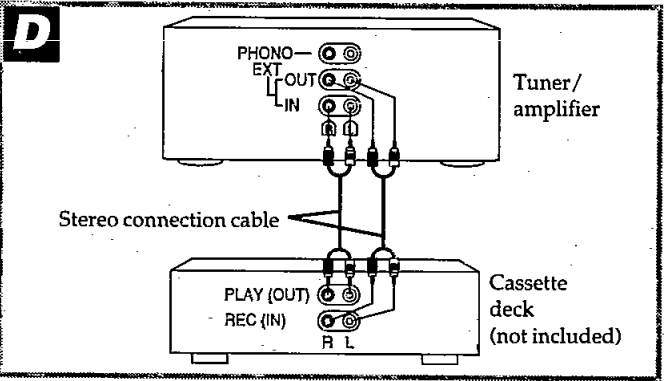
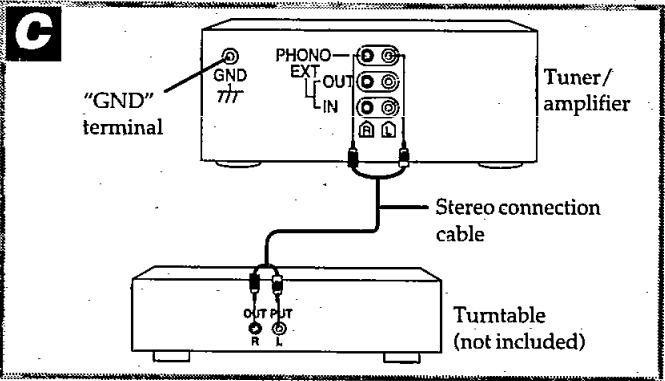
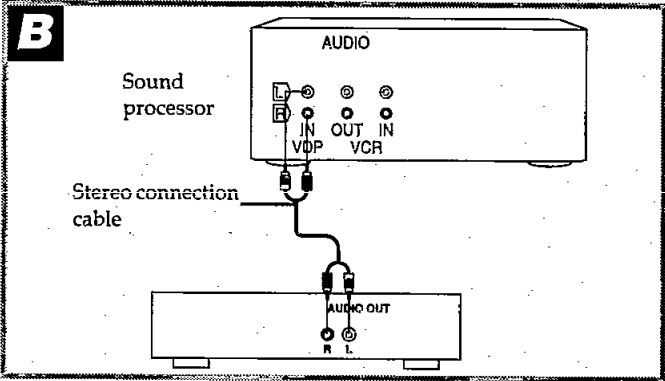
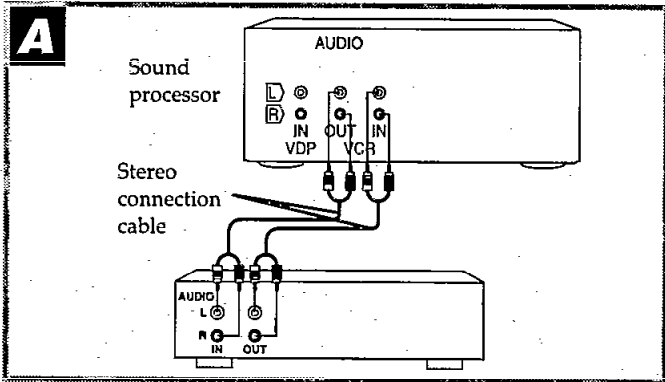

External unit connections

- Make sure that the power supply for all components has been turned off before making any connections.
- For details, refer to the operating instructions of the units which are to be connected.
- All peripheral components and cables sold separately.

Stereo connection cable
White (L)
Red (R)

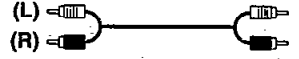

A Video Cassette recorder

B Laser disc player

C Turntable

"GND" terminal:
This terminal is for a ground wire.

D Cassette deck

Optional antenna connections

You may need an outdoor antenna if you use this system in a mountainous region or inside a reinforced-concrete building, etc.

FM outdoor antenna (not included) E

Note

An outdoor antenna should be installed by a qualified technician only.

AM outdoor antenna (not included) E

Connect the outdoor antenna without removing the AM loop antenna. Run 5 to 12 m of vinyl-covered wire horizontally along a window or other convenient location.

Note

When the unit is not in use, disconnect the outdoor antenna to prevent possible damage that may be caused by lightning. Never use an outdoor antenna during an electrical storm.

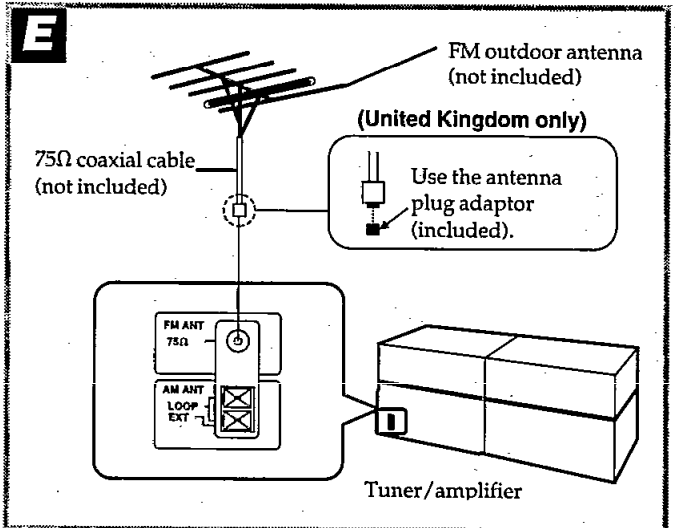

■ Enjoying RDS Broadcasts [For (EG) and (EP) areas]

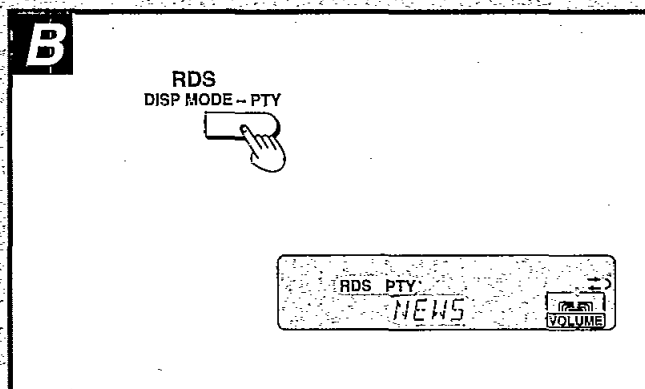
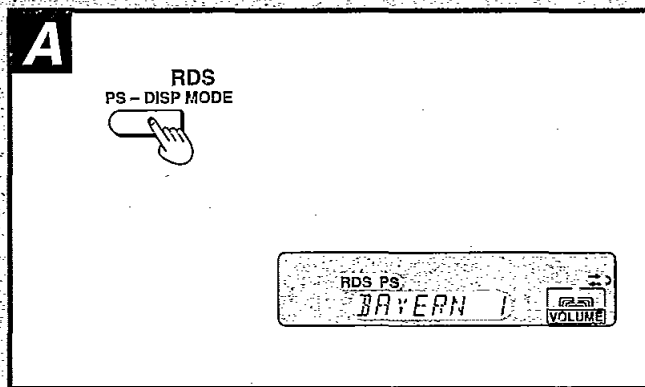
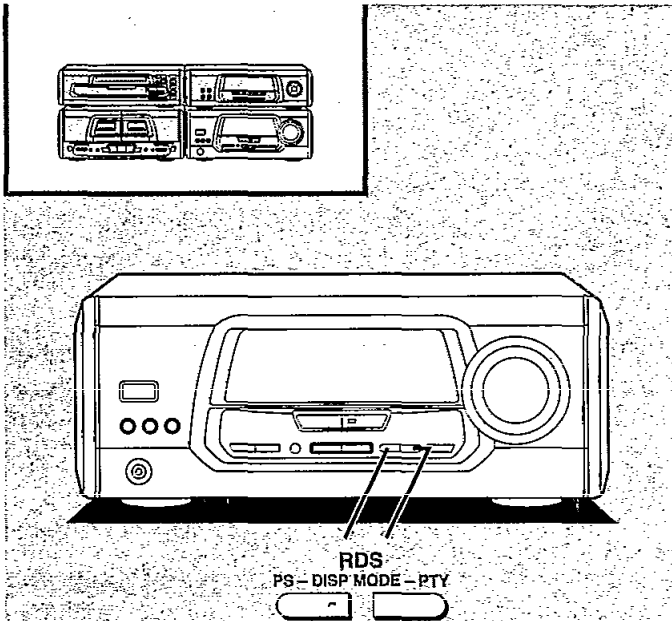

This unit lets you take advantage of the Radio Data System (RDS) in areas where RDS broadcast services are received. This advanced system provides useful information, utilizing a 57 kHz subcarrier above the audible range, in addition to the main FM signal.

Types of RDS and functions

To display the name of a broadcast station (PS display):
When this system receives a PS signal in an RDS broadcast, the name of the broadcast station is shown on the display.

To display the type of a program (PTY display):
While the PTY signal is being received, the name of the type of program currently being broadcast can be shown on the display.

Notes

- Even if an FM broadcast station is transmitting RDS signals, the functions of this system may not be able to utilize these signals if the signal quality is too poor.
- "PTY" may not be available in some areas. (Future function)

To display the name of a broadcasting station ^A

(When the FM station is received)

Press PS-DISP MODE.

If the FM broadcast being received provides the RDS service ("RDS" indicator will light), the name of the broadcast station and "PS" indicator will be shown on the display of this system.

Each time you press the button, frequency display and PS display will appear alternately.

To display the type of a program ^B

(When the FM station is received)

Press DISP MODE-PTY.

If the FM broadcast being received provides the RDS service ("RDS" indicator will light), the type of the program and "PTY" indicator will be shown on the display of this system.

Each time you press the button, frequency display and PTY display will appear alternately.

Note

When receiving a broadcast station, in PTY mode, which does not transmit PTY, the display will not show "NO PTY" automatically.

Setting the time

About the PTY display

There are a total of 15 PTY displays on this unit. The table gives an explanation of each display.

Display	Explanation
NEWS	Short accounts of facts, events and publicly expressed views, reportage and actuality.
AFFAIRS	Topical program expanding or enlarging upon the news, generally in different presentation style or concept, including documentary debate, or analysis.
INFO	Program whose purpose is to impart advice in the widest sense, including meteorological reports and forecasts, consumer affairs, medical help, etc.
SPORT	Program concerned with any aspect of sport.
EDUCATE	Program intended primarily to educate.
DRAMA	All radio plays and serials.
CULTURE	Programs concerned with any aspect of national or regional culture, including religious affairs, philosophy, social science, language, theatre, etc.
SCIENCE	Programs about the natural sciences and technology.
VARIED	Used for mainly speech-based programs, usually of a light-entertainment nature not covered by above categories. Examples are: quizzes, panel games, personality interviews, comedy and satire.
POP M	Commercial music which would generally be considered to be of current popular appeal, often featuring in current or recent record sales charts.
ROCK M	Contemporary modern music, usually written and performed by young musicians.
M.O.R.M	(Middle of the Road Music). Common term to describe music considered to be "easy-listening", as opposed to Pop, Rock or Classical. Music in this category is often, but not always, vocal, and usually of short duration (<5 min.).
LIGHT M	Classical Musical for general, rather than specialist, appreciation. Examples of music in this category are instrumental music and vocal or choral works.
CLASSICS	Performances of major orchestral works, symphonies, chamber music etc., and including Grand Opera.
OTHER M	Musical styles not fitting into any of the above categories. Particularly used for specialist music, of which Jazz, Rhythm & Blues, Folk, Country, and Reggae are examples.

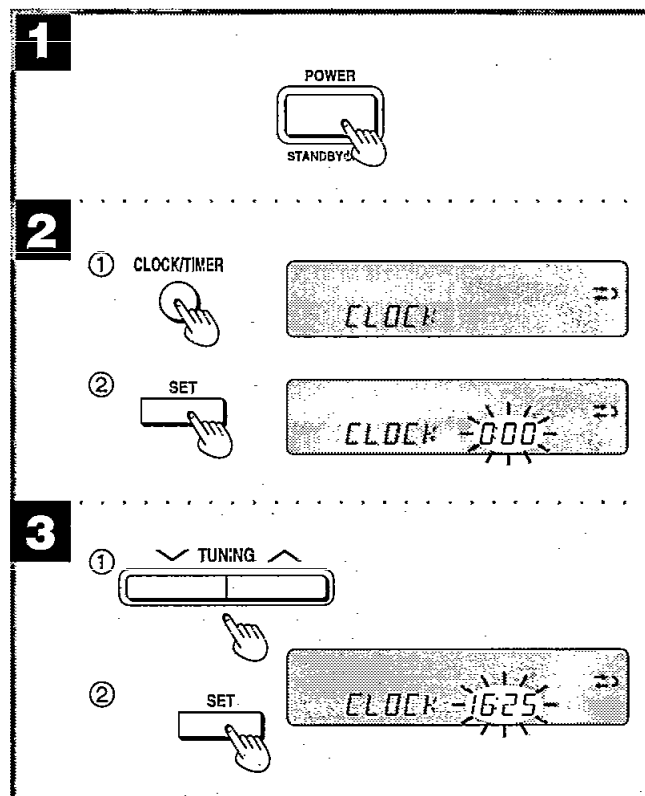
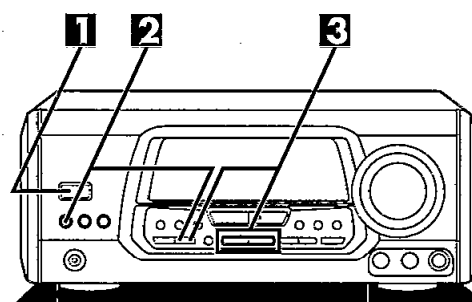

The tuner/amplifier displays the time, frequency and other information on CDs and tapes.

This is a 24-hour display clock.

The figure shows how to set the time for 16:25.

1 Switch on the power.

2 ① Press CLOCK/TIMER to show "CLOCK".

Every time you press the button, the indication changes in the order of CLOCK→⊕ PLAY→⊕ REC→Original display.

Within 5 seconds:

② Press SET.

3 ① Press TUNING (∨ or ∧) to set the present time on the display.

The time display can be changed in one minute units by tapping the buttons, and quickly by holding down the buttons.

② Press SET.

The display will return to the previous display after about 3 seconds.

■ Enjoying Sound with DOLBY PRO LOGIC

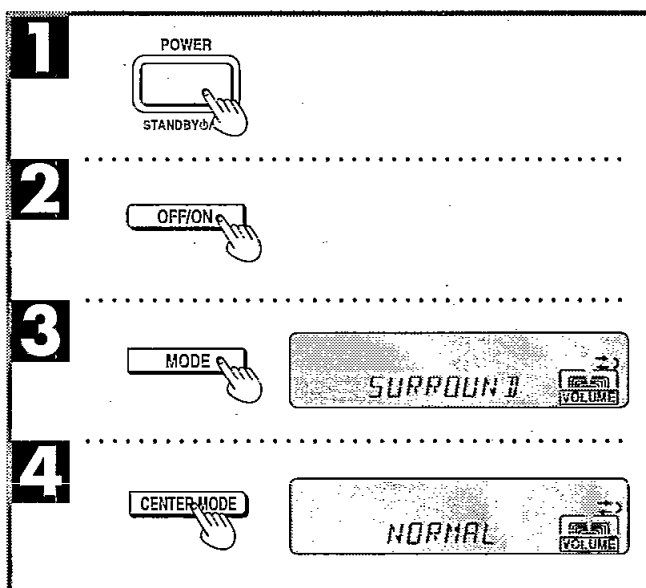
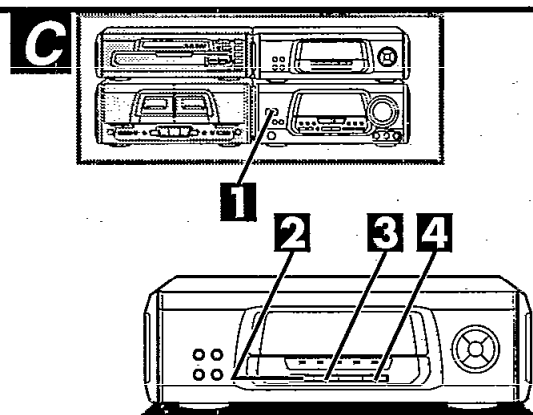
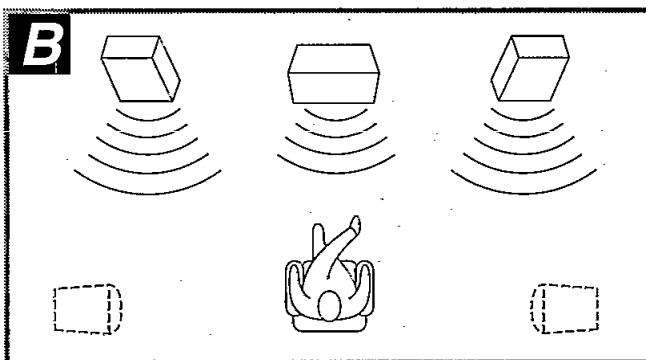
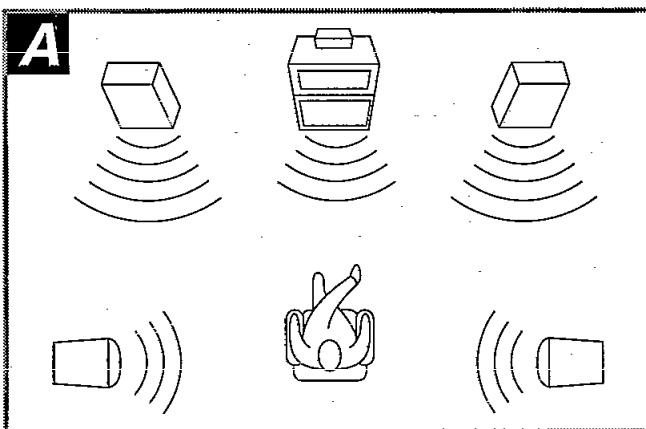

By combining front, center and surround speakers, you can enjoy the SURROUND mode which conveys a feeling of presence or the 3 STEREO mode which conveys a feeling of orientation.

SURROUND **A**

By reproducing the feeling of depth and movement of sound, video software or compact discs recorded with DOLBY SURROUND provide the listener with the sensations of a movie theater.

To enjoy SURROUND, be sure to connect the surround speakers.

3 STEREO **B**

You can enjoy audio/video sources with clear sound, more presence and enhanced orientation. 3 STEREO can be used with sources not recorded in DOLBY SURROUND.

To enjoy 3 STEREO, be sure to connect the center speaker.

Manufactured under license from Dolby Laboratories Licensing Corporation.
DOLBY, the double-D symbol  and "PRO LOGIC" are trademarks of Dolby Laboratories Licensing Corporation.

Setting the center mode **C**

For Dolby Pro Logic systems, center mode setting is necessary to play back bass sounds effectively. Set the center mode in accordance with the size of your center speaker.

- 1** Switch on the power.
- 2** Press DOLBY PRO LOGIC OFF/ON to select ON.
- 3** Press MODE to select "SURROUND" or "3 STEREO".
Each time you press the button, the display will change as follows:
SURROUND → 3 STEREO
↑
The selected mode's indicator lights.
- 4** Press CENTER MODE to select "NORMAL" mode.
Each time you press the button, the display will change as follows:
NORMAL → WIDE → PHANTOM
↑
The selected mode's indicator lights.

Note

"PHANTOM" will not be displayed when you select "3 STEREO" in step 3.

NORMAL:

When the center speaker is smaller than the front speakers

WIDE:

When the center speaker is the same size or larger than the front speakers

PHANTOM: SURROUND only

When no center speaker is connected

Note

In the PHANTOM mode, the sound which would have been sent to the center speaker will be divided equally between both the left and right front speakers.

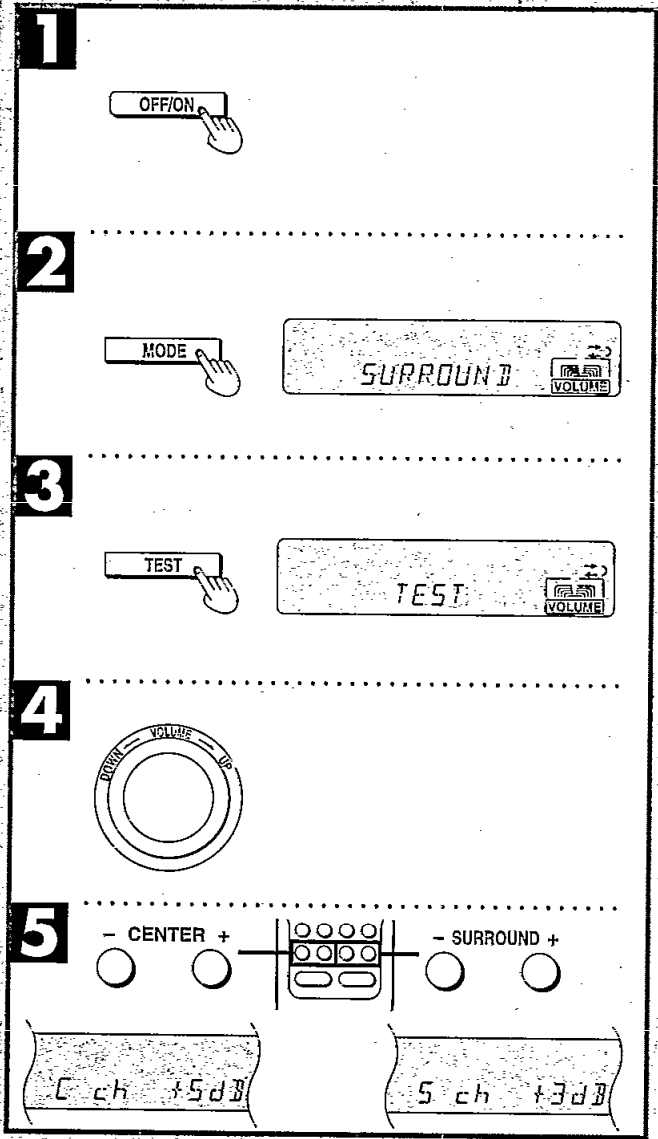
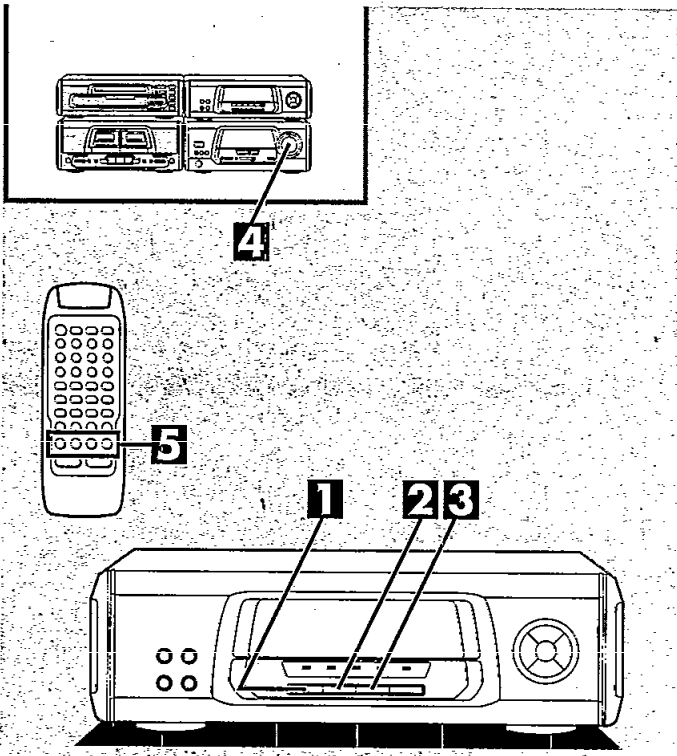

Adjusting speaker output level

In order to reproduce the movement of the sound and its clear orientation, it is important to adjust the output level of each speaker. Adjust output to the correct levels while listening to the test signal.

1 Press DOLBY PRO LOGIC OFF/ON to select ON.

2 Press MODE to select "SURROUND" or "3 STEREO".
Each time you press the button, the display will change as follows:
SURROUND → 3 STEREO

3 Press TEST to output a test signal.
The test signal is emitted in the following order:
For SURROUND mode
Front speaker (left) → Center speaker
Surround speakers (left, right) ← Front speaker (right)

Note
The test signal is not emitted from the center speaker when the center mode is on PHANTOM.

For 3 STEREO mode
Front speaker (left) → Center speaker → Front speaker (right)

4 Turn VOLUME to set the volume level normally used for enjoying the source.

5 Press CENTER (-) or (+) or SURROUND (-) or (+) on the remote control to adjust the output level balance.
Adjust the output level of each speaker from the listening position until they are all identical.
Output levels can be varied within a range of ±12 dB with front speaker output level serving as the zero point.

Notes
• The test signal is output only by the speaker you are now adjusting and does not repeat the sequence until adjustments are complete.
• Remember you cannot adjust the output level of the surround speakers if you selected the 3 STEREO mode in step 2.

To stop the test signal:
Press TEST.

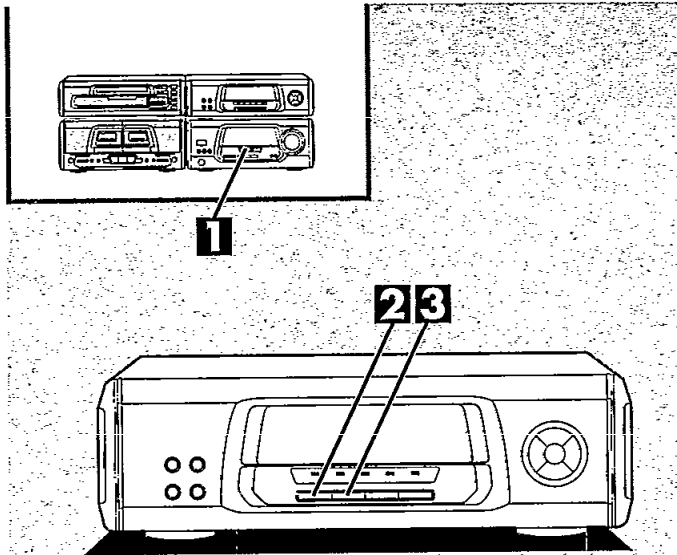

Enjoying SURROUND or 3 STEREO

Before trying anything, have you set the center mode and adjusted speaker output level?
 When viewing a video, turn on the power supply for the TV and set the TV to video mode.

1 Press INPUT SELECTOR to select the desired external source.

Each time you press this button, sound sources will be switched as follows.
 TUNER → CD → TAPE
 ↑ ↓
 PHONO ← VDP ← VCR ← EXT

These indications correspond to terminals on the rear panel of the sound processor or tuner/amplifier. Switch the displayed indication to the source you want to use.

2 Press DOLBY PRO LOGIC OFF/ON to select ON.

3 Press MODE to select "SURROUND" or "3 STEREO".

4 Start the desired source.

To operate external sources, refer to the operating instructions provided with the specific unit.

Note
 When using SURROUND, use software recorded in Dolby Surround.

To turn off the DOLBY PRO LOGIC systems:
 Press DOLBY PRO LOGIC OFF/ON to select "OFF".

Note
 You cannot record acoustical effects produced in the SURROUND and 3 STEREO modes.

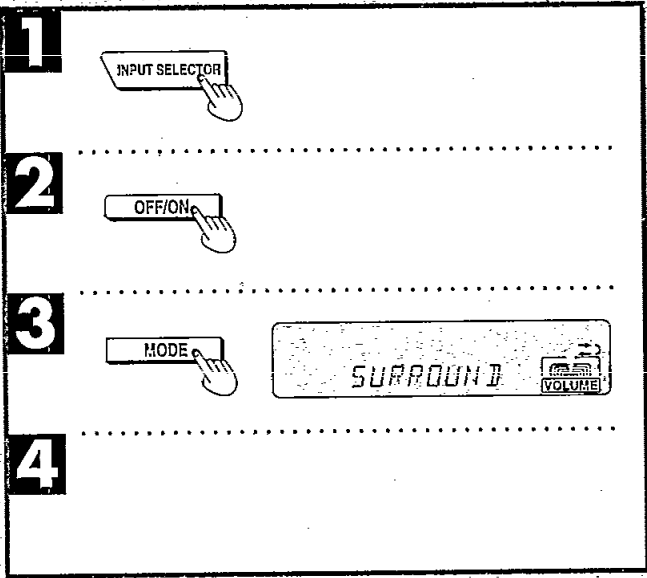

Operation Checks and Main Component Replacement Procedures

NOTE

1. This section describes procedures for checking the operation of the major printed circuit boards and replacing the main components.
2. For reassembly after operation checks or replacement, reverse the respective procedures. Special reassembly procedures are described only when required.
3. Select items from the following index when checks or replacement are required.
4. Refer the parts No. on the page of "Main Component Replacement Procedures", if necessary.

• Contents

■ Checking Procedure for each P.C.B.	Page.
1. Checking for the tuner P.C.B., dolby prologic P.C.B. and power supply P.C.B.	13.
2. Checking for the operation P.C.B.	14.
3. Checking for the main P.C.B.	14,15.
 ■ Main Component Replacement Procedures	
1. Replacement for the power IC and regulator transistor.	16.

Checking Procedure for each P.C.B.

1. Checking for the tuner P.C.B., dolby prologic P.C.B. and power supply P.C.B.

• Check the tuner P.C.B., dolby prologic P.C.B. and power supply P.C.B. as shown below.

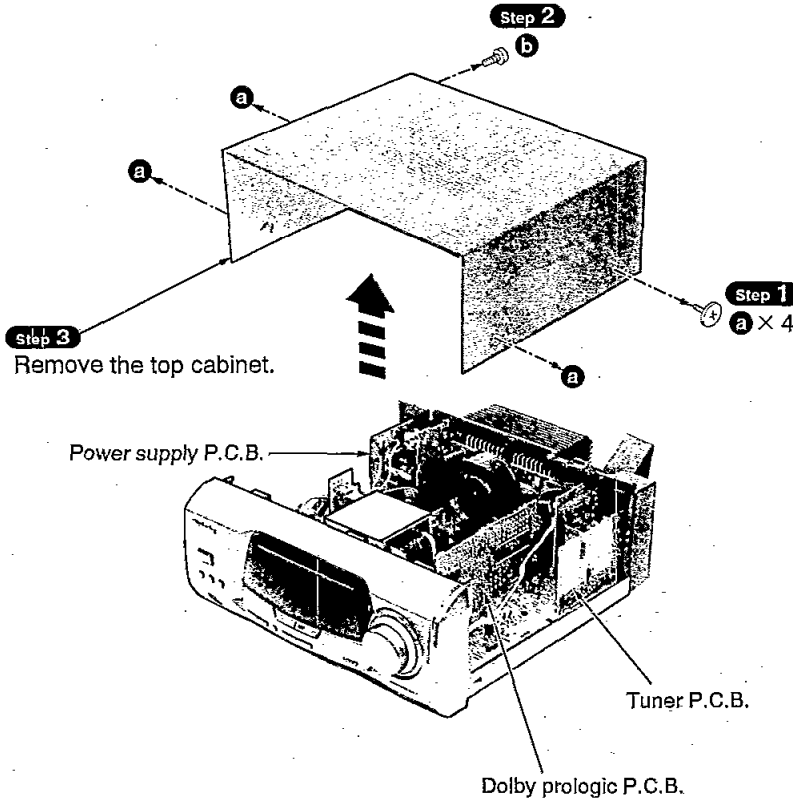

2. Checking for the operation P.C.B.

- Follow the **Step 1** ~ **Step 3** of the item 1 in checking procedure for each P.C.B. on page 13.

Step 2

pull out the front panel ass'y.

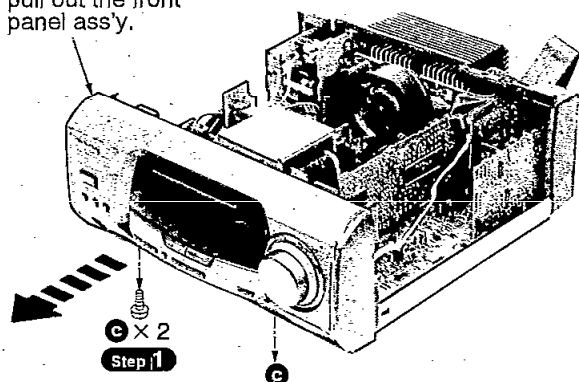

- Check the operation P.C.B. as shown below.

Operation P.C.B.

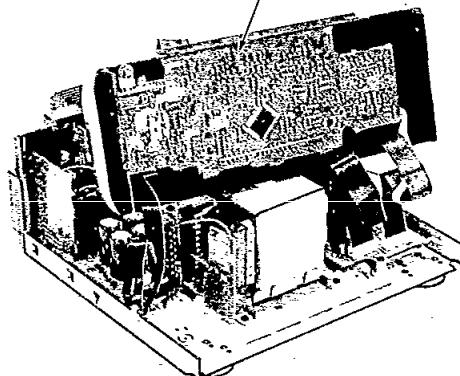

3. Checking for the main P.C.B.

- Follow the **Step 1** ~ **Step 3** of the item 1 in checking procedure for each P.C.B. on page 13.

Step 1

Remove the cable holder.

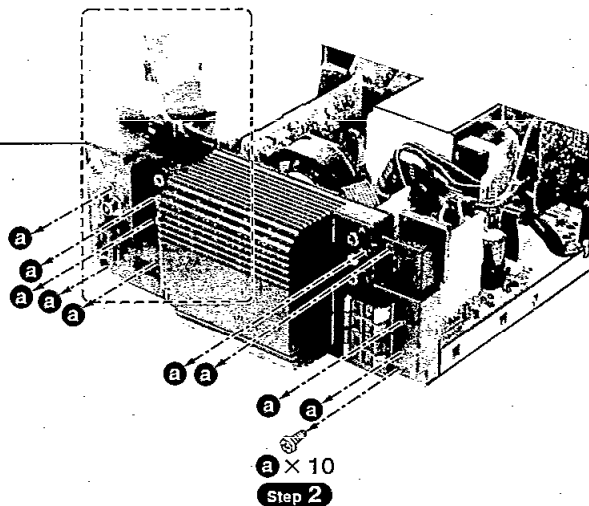
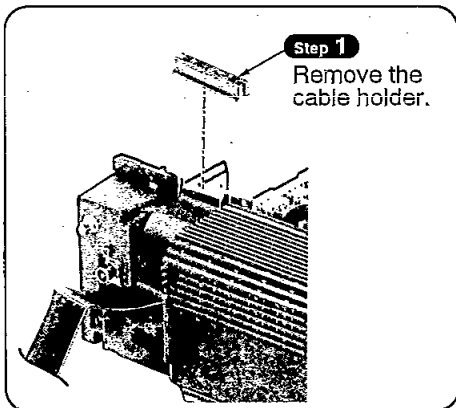

Step 3

Release the 3 claws, and then remove the rear grille ass'y.

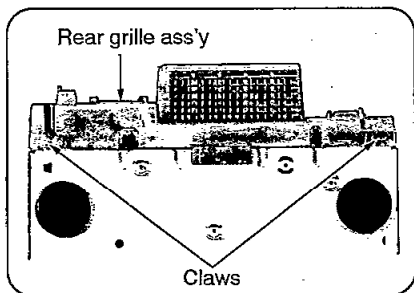

(Bottom)

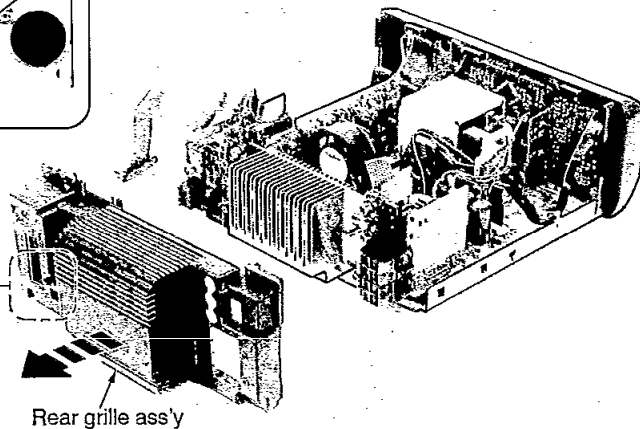
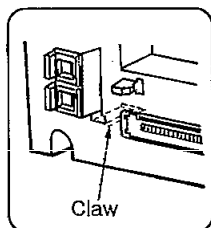

Notice for installation of rear grille ass'y

Align the partition of rear grille ass'y with the marking (▲) on the heat sink.

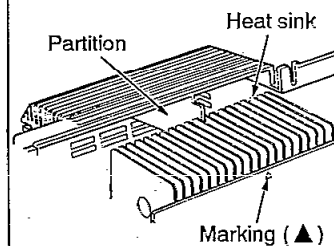

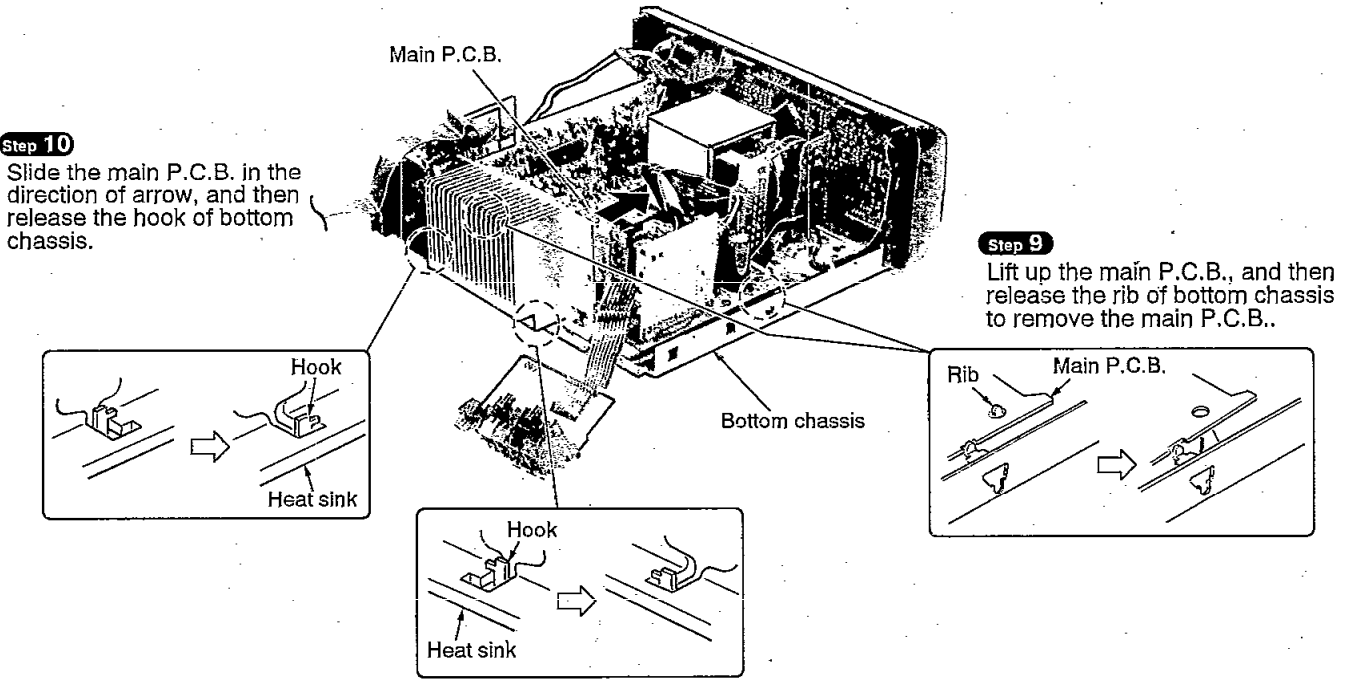
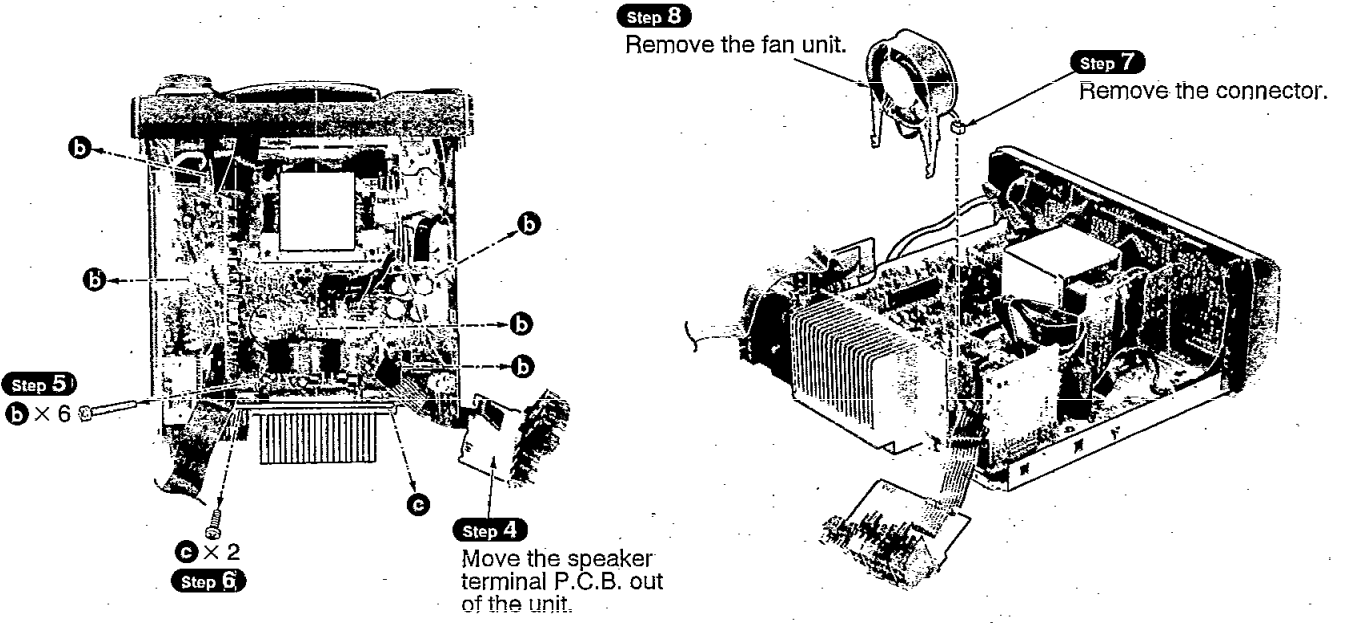

• Check the main P.C.B. as shown below.

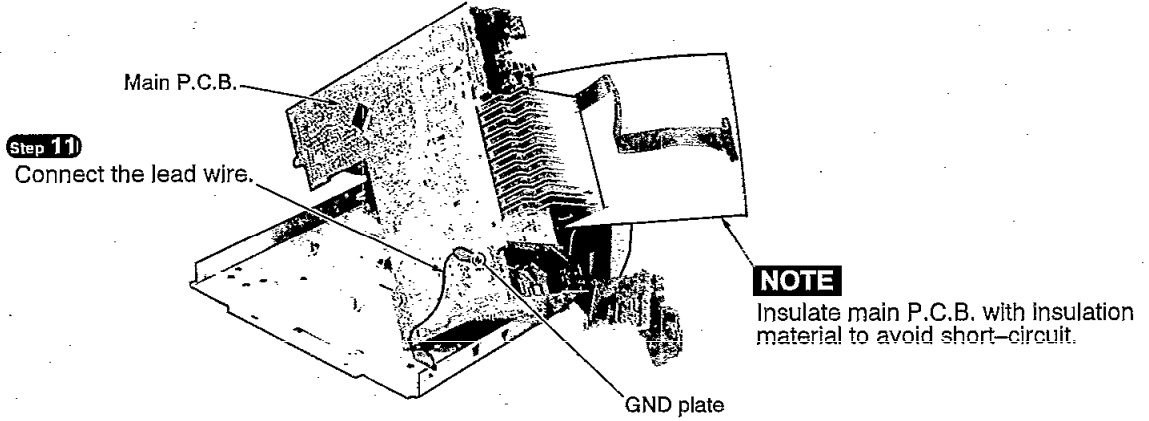

■ Main Component Replacement procedures

1. Replacement for the power IC and regulator transistor

- Follow the **Step 1** ~ **Step 3** of the item 1 in checking procedure for each P.C.B. on page 13.
- Follow the **Step 1** ~ **Step 10** of the item 3 in checking procedure for each P.C.B. on pages 14 and 15.

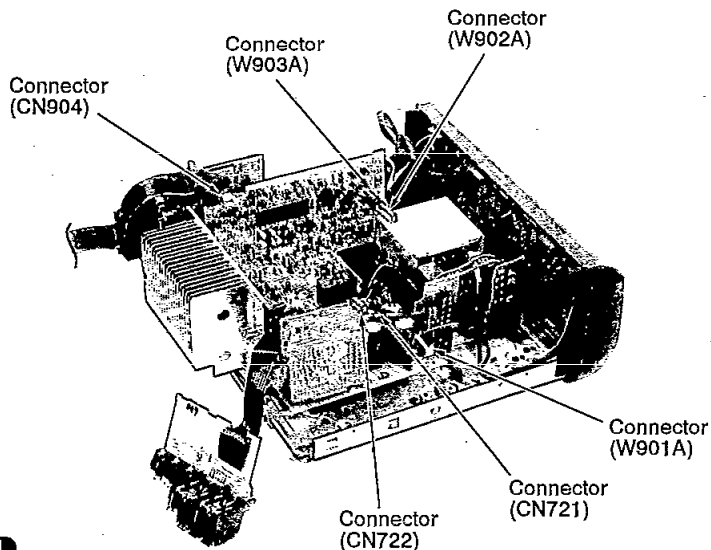

Step 1

Remove the flat cables from connectors.

■ Removal of the connector

- Connectors (W901A, W902A, W903A)

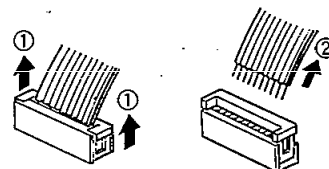

- Connectors (CN721, CN722, CN904)

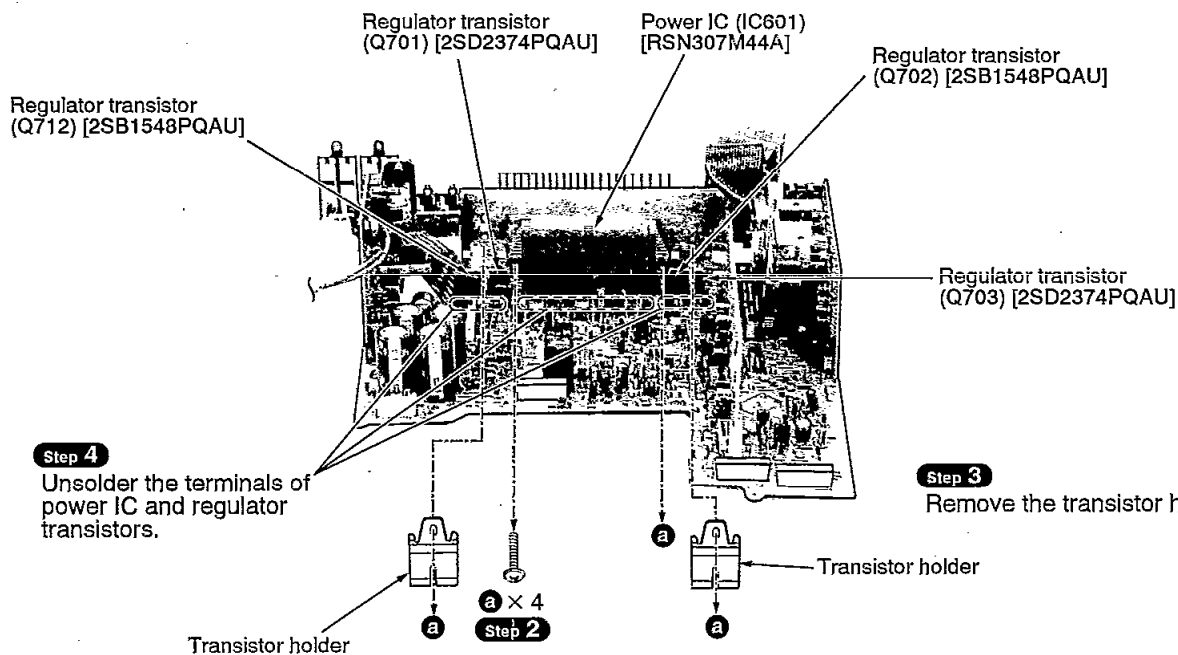
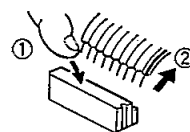

Step 4

Unsolder the terminals of power IC and regulator transistors.

Step 3

Remove the transistor holder.

NOTE

When mounting the power IC or regulator transistor apply silicone compound (RFKX0002) to the rear side of power IC or regulator transistors.

■ To Supply Power Source

This unit SA-EH600 is designed to operate on power supplied from the system connected. (For system connection, refer to Fig.1)

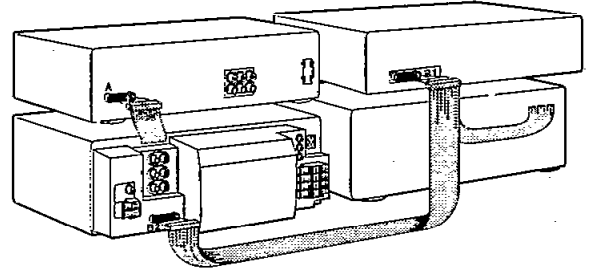

Fig. 1

When you have to test and service the unit SA-EH600 alone, use the following method to supply power source and operate the unit:

1. Short the section between 7 pin and 10 pin of the connector W202 in Fig. 2.
2. Connect this unit to an AC Power Cord.
(This unit come to stand-by mode.)
3. Turn the unit ON.

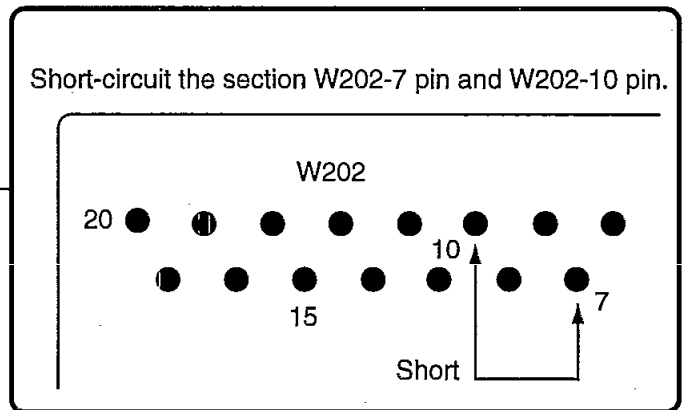
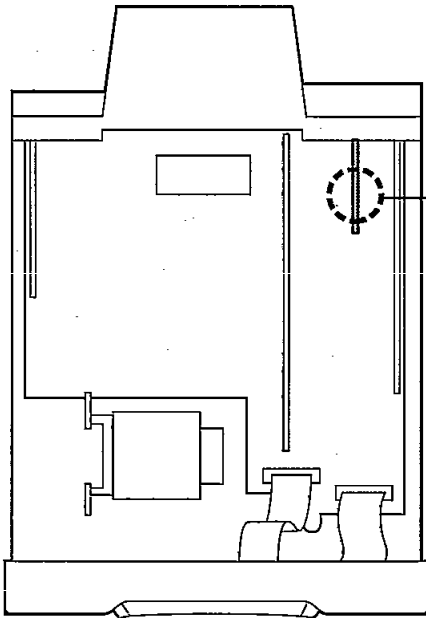

Fig. 2

■ To Check Operation

1. Set this unit to Power.ON mode.
2. Input a signal and confirm it to be outputted from the speaker terminal.

	INPUT	OUTPUT
L-ch	EXT IN	L-ch speaker terminal
R-ch	EXT IN	L-ch speaker terminal
Surround	EXT IN	Surround speaker terminal
Center	EXT IN	Center speaker terminal

About the Self-Diagnostic Mode

This unit is equipped with a self-diagnostic function which, in the event of a malfunction, automatically displays a code indicating the nature of the malfunction. Use this self-diagnostic function when servicing the unit.

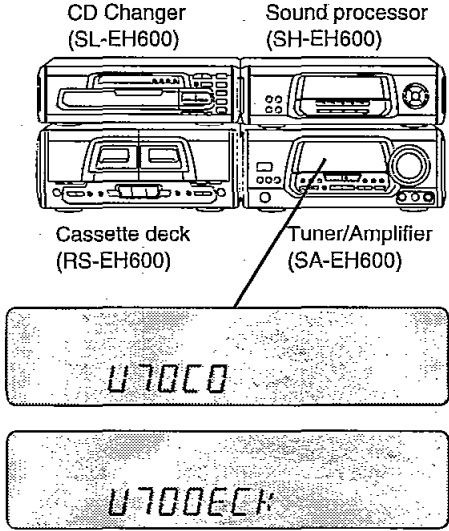
Display method	Display location
<p>To display the malfunction code</p> <p>U-70 CD: U-70 DECK: Automatically displays on the tuner/sound processor when a malfunction occurs.</p> <p>F-61 Automatically displays on the tuner/sound processor when a malfunction occurs.</p> <p>To return to the normal display</p> <p>1. For U-70 CD/U-70 DECK: <ul style="list-style-type: none"> ● Press any operation button on the tuner/amplifier. ● To re-display the code, switch the power off (POWER STANDBY button), and then switch power back on again. </p> <p>2. For F-61: <ul style="list-style-type: none"> ● If "F-61" is displayed, the power will automatically be switched off and the standby indicator will light up. ● "F-61" will be displayed for 3 seconds, and then the clock will be displayed. ● To re-display the code, switch the power on. "F-61" will be re-displayed, and then after 3 seconds the clock will be displayed and the power will automatically switch off. </p>	

Display contents

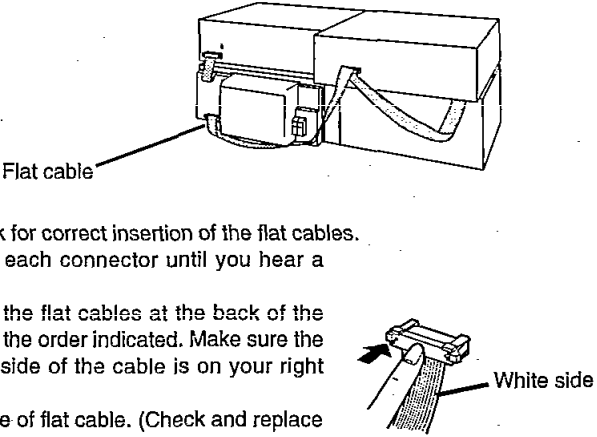
Display code	Problem or condition	Correction procedure
<p>U-70 CD U-70 DECK (displayed automatically)</p>	<p>A bus-line communications error has occurred as a result of the flat cables being inserted incorrectly, thus preventing the system from operating.</p> <p>1. If "U-70" is displayed on the tuner/amplifier, the tape deck or CD Changer cannot be operated by remote control.</p>	 <p>1. To check for correct insertion of the flat cables. ① Insert each connector until you hear a click. ② Insert the flat cables at the back of the unit in the order indicated. Make sure the white side of the cable is on your right side.</p> <p>2. Breakage of flat cable. (Check and replace as necessary.)</p> <p>3. If the problem is not corrected by items (1.) and (2.) above, this indicates a faulty IC.</p> <p>SA-EH600: IC901 (M38199MF105K)</p> <p>SL-EH600: IC401 (LC66538A4K17)</p> <p>RS-EH600: IC701 (M37471M4679F)</p> <p>Check these IC's and replace as necessary.</p>
<p>F-61</p>	<p>When the power switch is switched on, it automatically switches back off, making it impossible to switch power on.</p>	<p>● Faulty Tuner/Amplifier (SA-EH600) output IC (IC601). (When a DC voltage is applied to the speaker terminals.)</p>

Schematic Diagram

	Page		Page
A TUNER CIRCUIT	20, 21	F POWER SUPPLY CIRCUIT	33, 34
B OPERATION CIRCUIT	22 - 24	G SPEAKER TERMINAL CIRCUIT	34
C DOLBY PRO LOGIC CIRCUIT	25 - 27	H POWER TRANSFORMER (A) CIRCUIT	34
D IN/OUT TERMINAL CIRCUIT	28	I POWER TRANSFORMER (B) CIRCUIT	34
E MAIN CIRCUIT	28 - 33		

• This schematic diagram may be modified at any time with the development of new technology.

Notes:

- S901 : Power "STANDBY ϕ /ON" switch (POWER STANDBY ϕ /ON)
- S902 : Clock/timer switch (CLOCK/TIMER)
- S903 : Record timer switch (Ⓜ REC)
- S904 : Play timer switch (Ⓜ PLAY)
- S905 : Tuning mode select switch (TUNING MODE)
- S906 : Set switch (SET)
- S907 : FM mode select switch (FM AUTO/MONO)
- S908 : Source input select switch (INPUT SELECTOR)
- S909 : Tuning down switch (TUNING v)
- S910 : Tuning up switch (TUNING ^)
- S911 : Tuner/band select switch (TUNER/BAND)
- S912 : Super woofer switch (S.WOOFER)
- S913 : RDS display mode select switch (PS-DISP MODE)
- S914 : RDS display mode select switch (DISP MODE-PTY)] For (EG) and (EP) areas
- VR901 : Volume control (VOLUME)

• Indicated voltage values are the standard values for the unit measured by the DC electronic circuit tester (high-impedance) with the chassis taken as standard. Therefore, there may exist some errors in the voltage values, depending on the internal impedance of the DC circuit tester.

No mark: FM () : AM

Important safety notice:

Components identified by \triangle mark have special characteristics important for safety.

Furthermore, special parts which have purposes of fire-retardant (resistors), high-quality sound (capacitors), low-noise (resistors), etc. are used. When replacing any of components, be sure to use only manufacturer's specified parts shown in the parts list.

Caution!

IC and LSI are sensitive to static electricity.

Secondary trouble can be prevented by taking care during repair.

Cover the parts boxes made of plastics with aluminum foil.

Ground the soldering iron.

Put a conductive mat on the work table.

Do not touch the legs of IC or LSI with the fingers directly.

Voltage and signal line

 : Positive voltage line

 : Negative voltage line

 : AM signal Line

 : Surround Speaker Drive signal line

 : AM OSC signal line

 : Center Speaker Drive signal line

 : FM signal line

 : FM OSC signal line

A TUNER CIRCUIT (P.C.Board: on page 35)

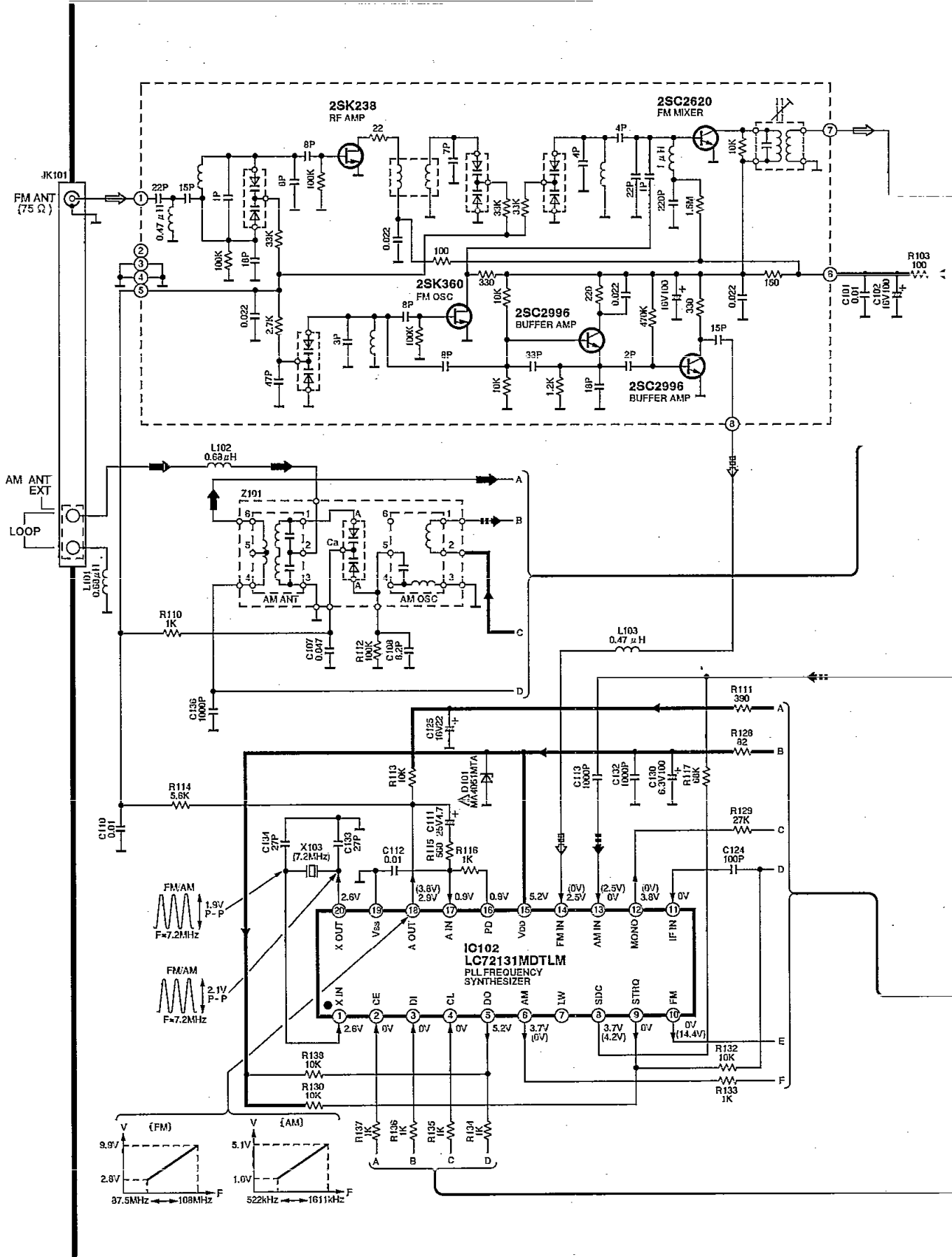

➔ : AM signal Line

▣▣▣➔ : AM OSC signal line

➔ : FM signal line

◻◻◻➔ : FM OSC signal line

➔ : Positive voltage line

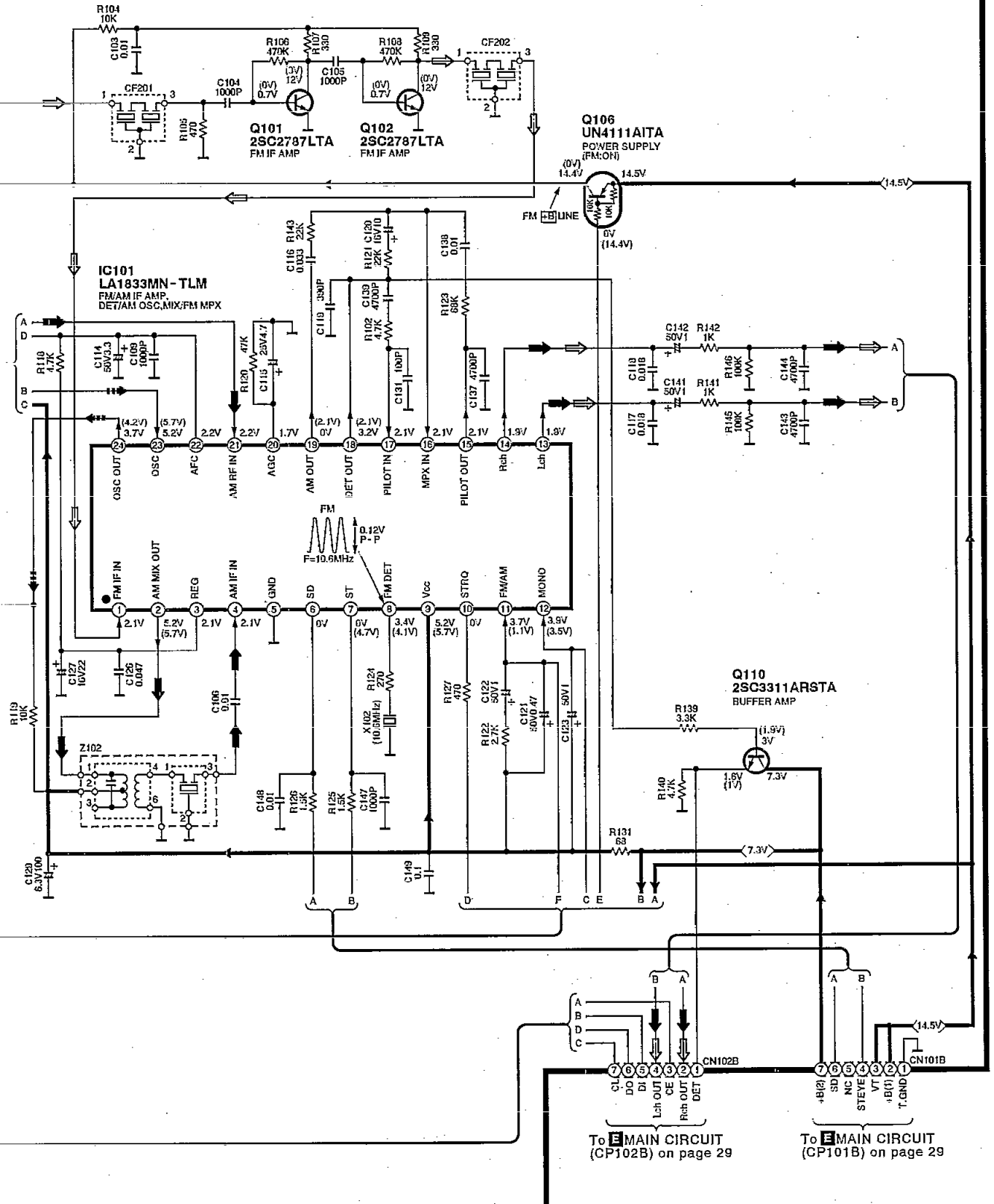

B OPERATION CIRCUIT (P.C.Board: on page 35)

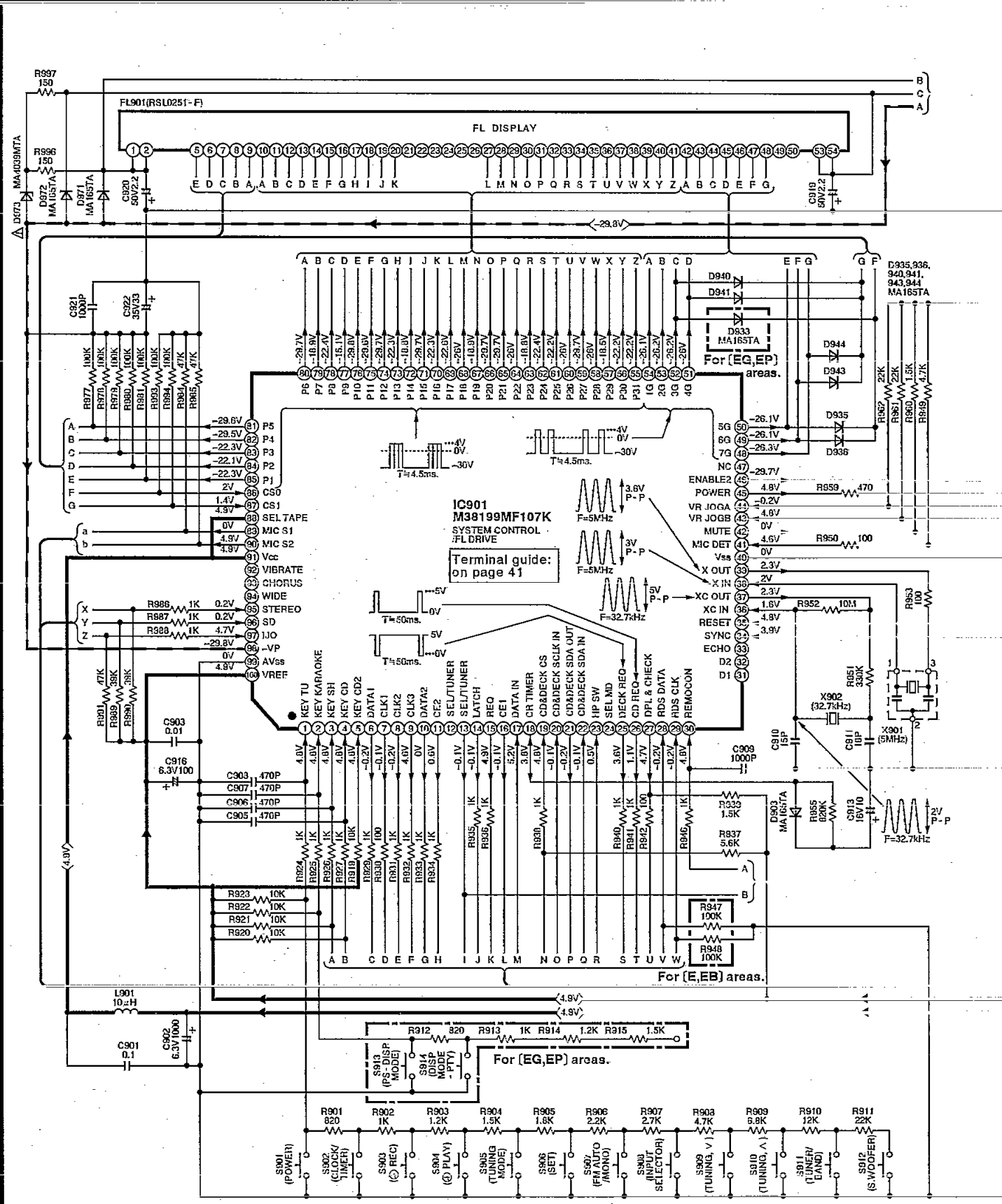

➔ : Positive voltage line

➔➔➔ : Negative voltage line

➔➔➔ : AM signal Line

➔➔➔ : FM signal line

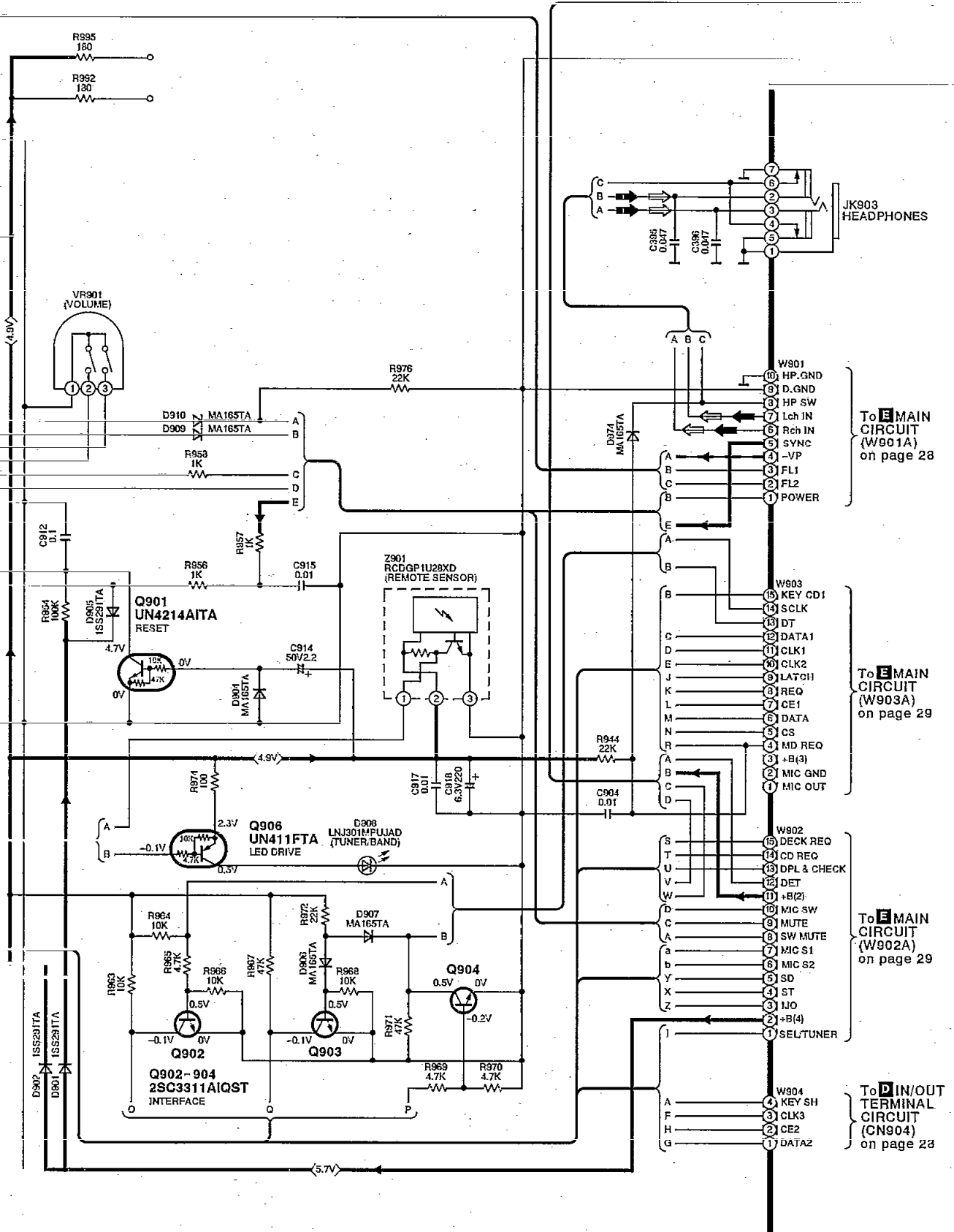

B OPERATION CIRCUIT (P.C.Board: on page 35)

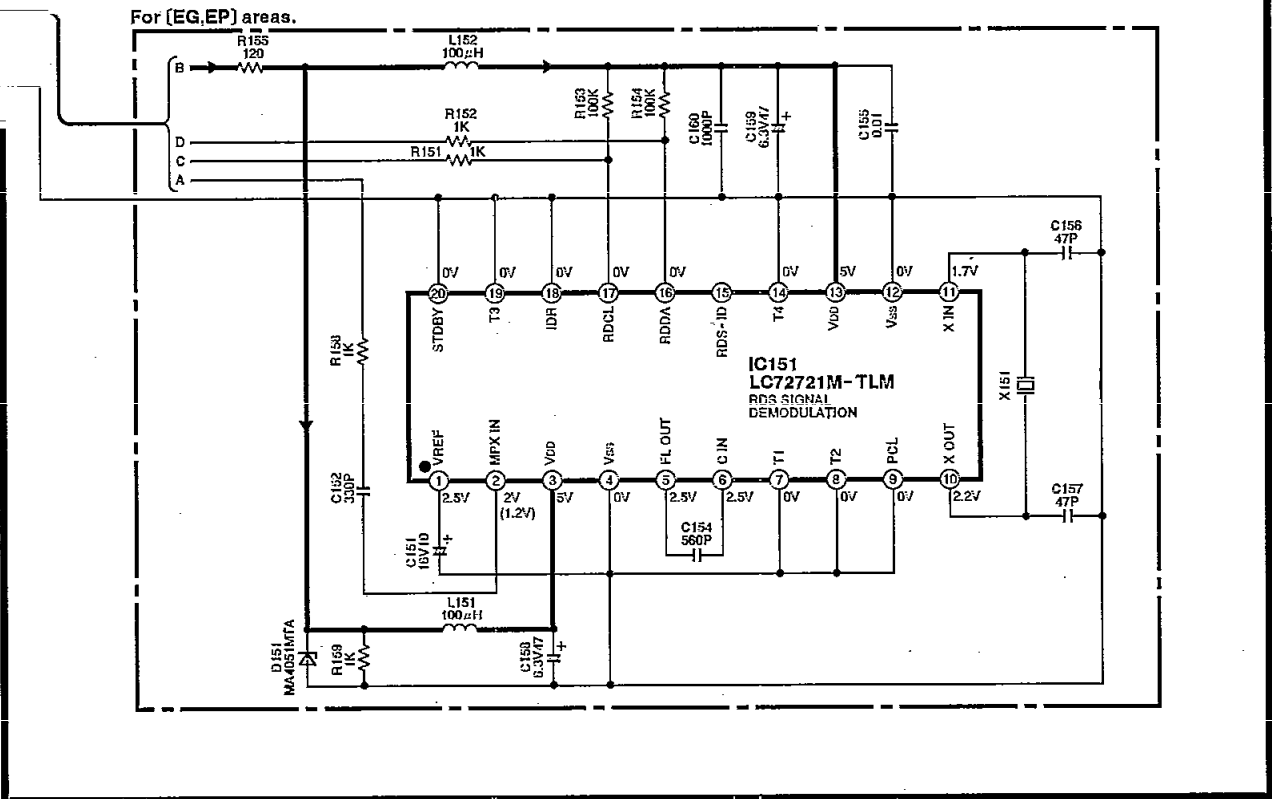

C DOLBY PROLOGIC CIRCUIT (P.C.Board: on page 37)

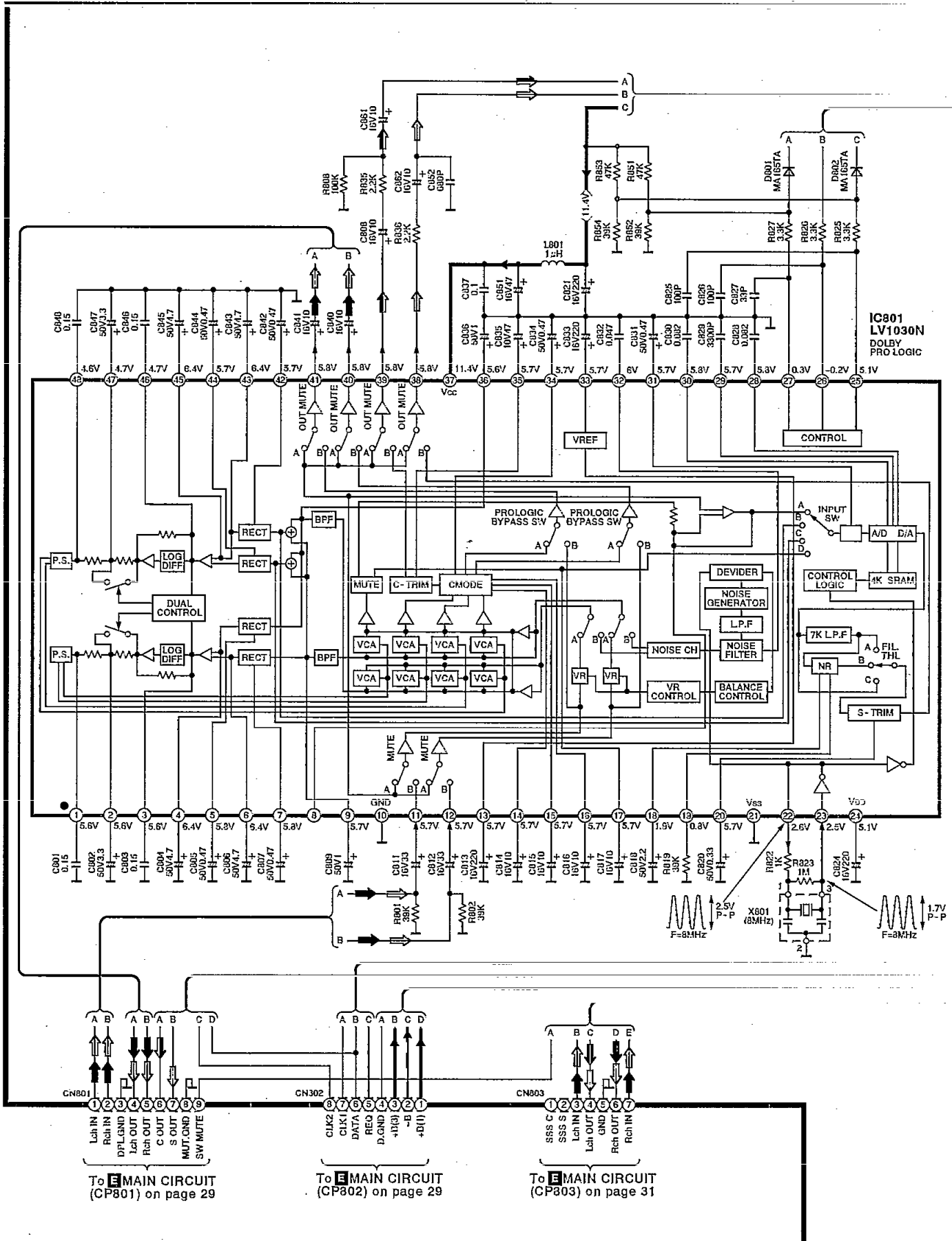

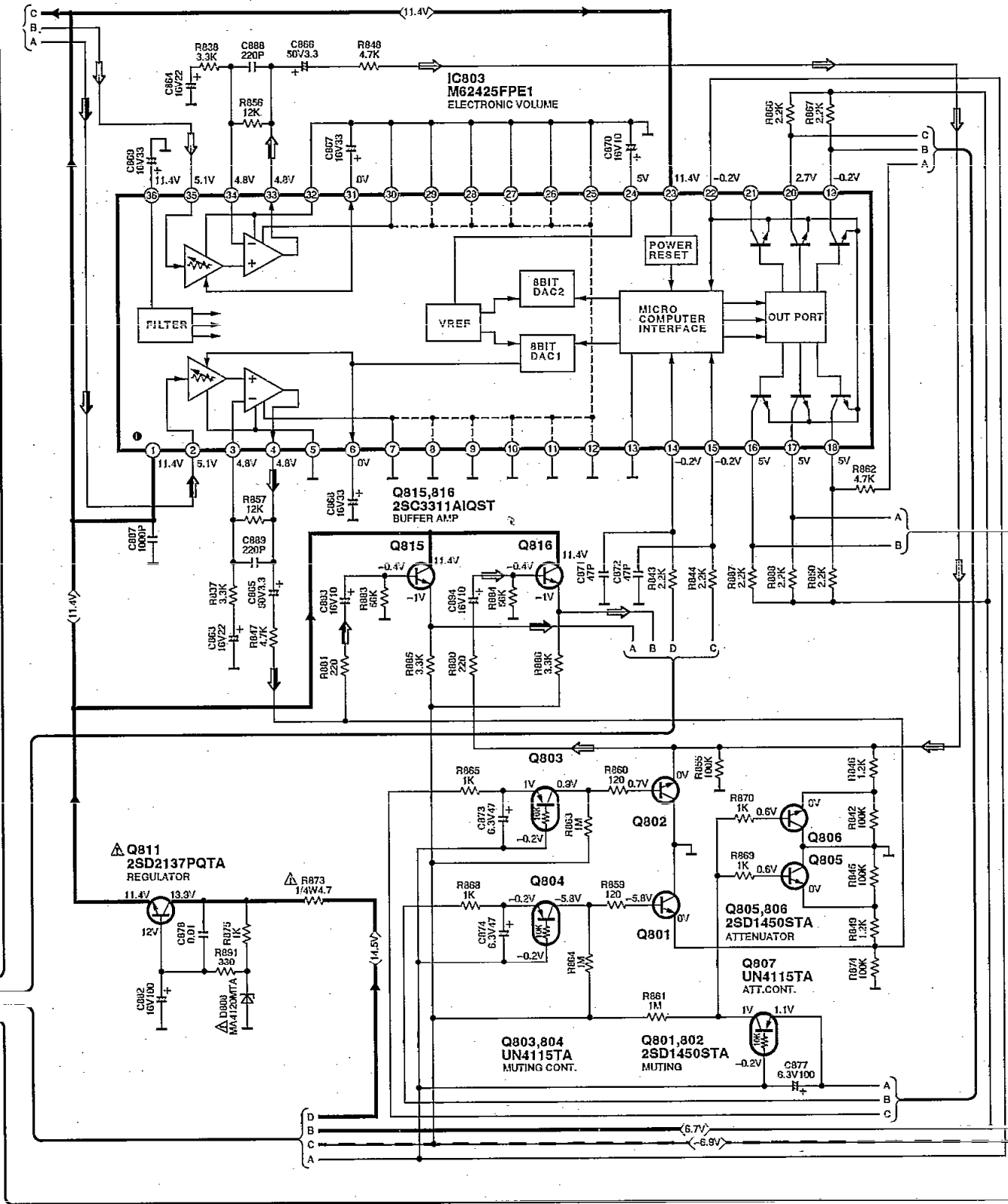

- : AM signal Line
- : Surround Speaker Drive signal line
- : Center Speaker Drive signal line
- : Positive voltage line
- : Negative voltage line

C DOLBY PROLOGIC CIRCUIT (P.C.Board: on page 37)

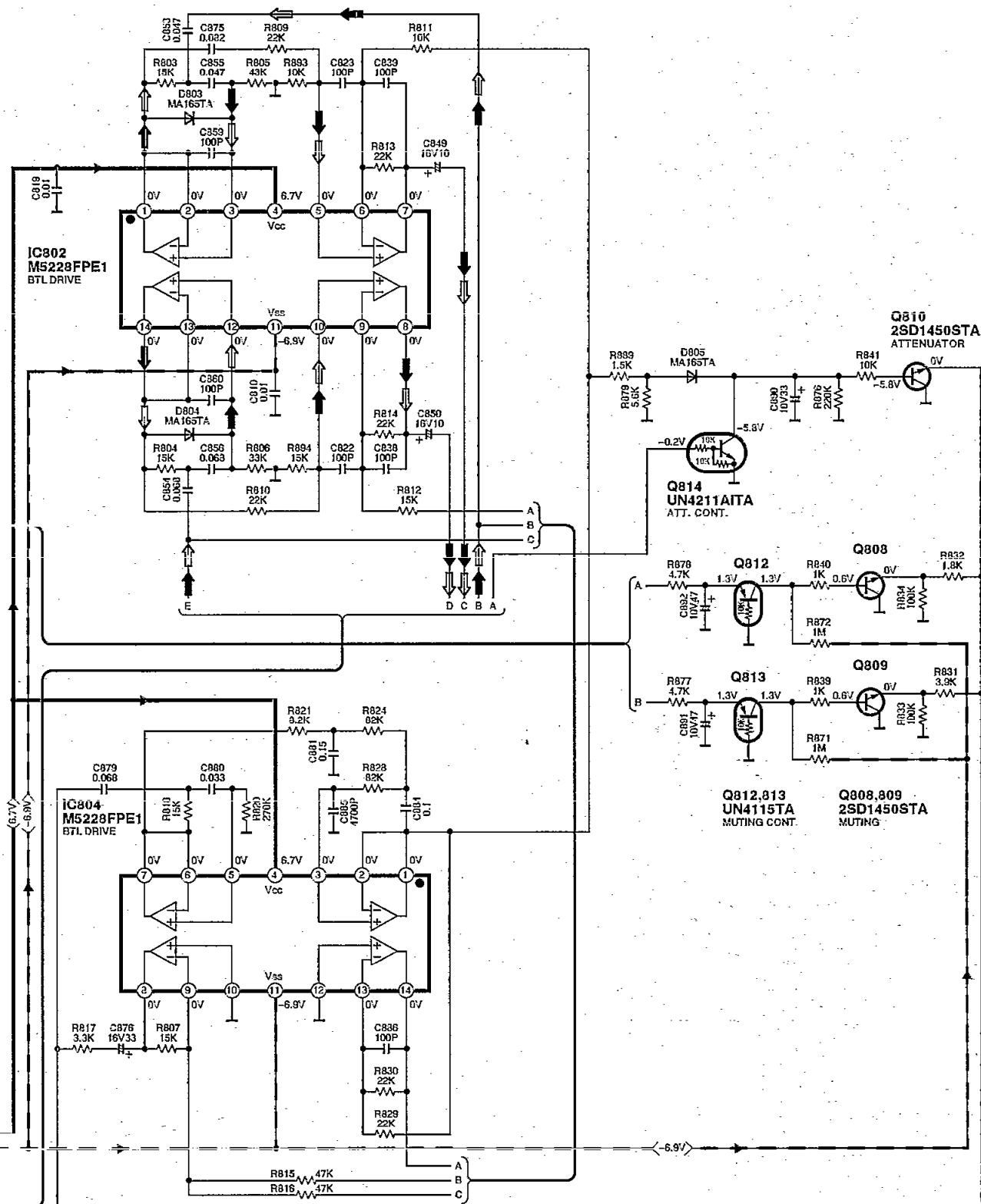

D IN/OUT TERMINAL CIRCUIT (P.C. Board : on page 37)

E MAIN CIRCUIT (P.C. Board: on pages 36,37)

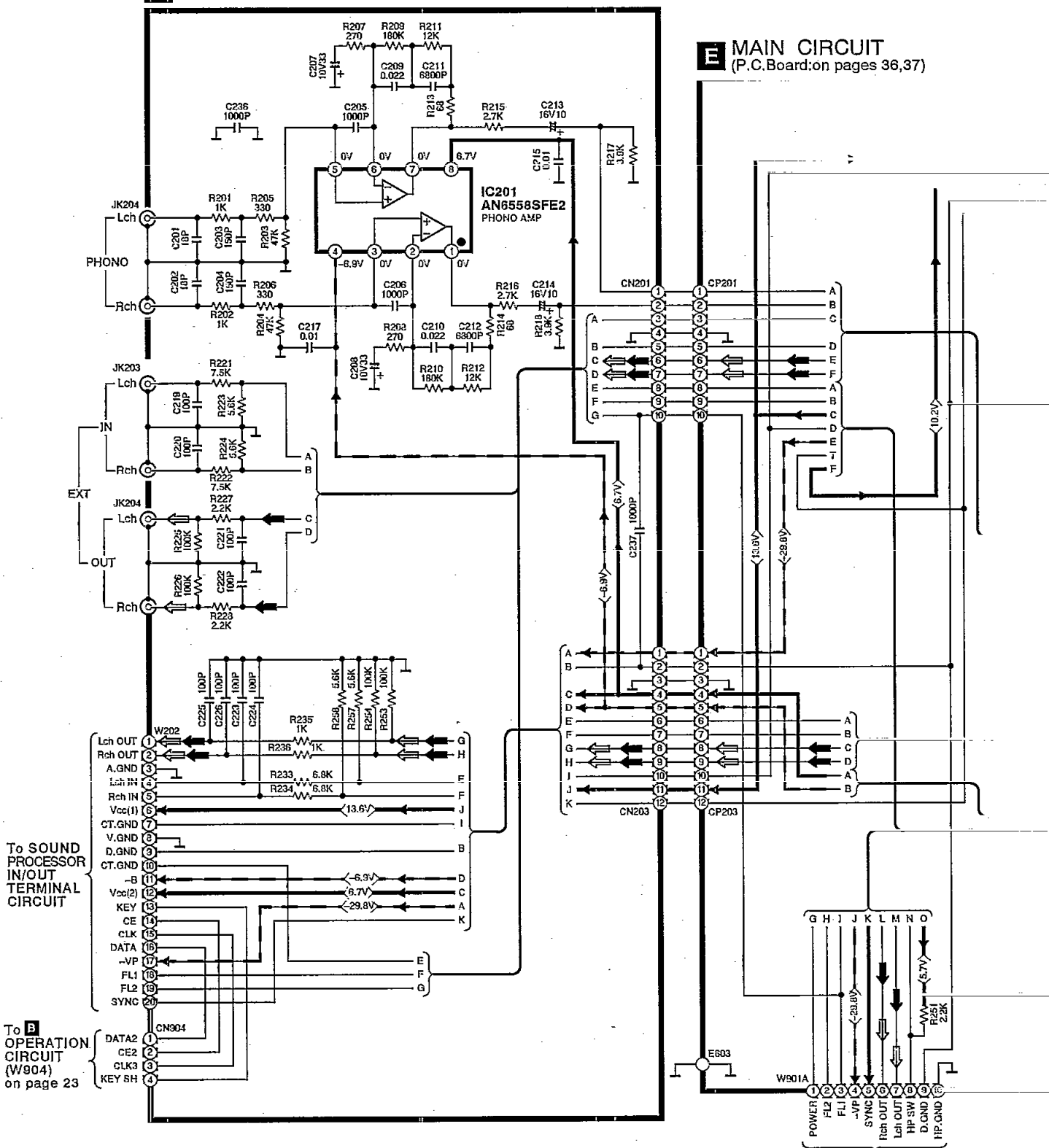

To **SOUND PROCESSOR** IN/OUT TERMINAL CIRCUIT

To **OPERATION CIRCUIT (W904)** on page 23

To **OPERATION CIRCUIT (W901)** on page 23

- ➔ : Positive voltage line
- ➔ : AM signal Line
- ➔ : Surround Speaker Drive signal line
- ➔ : Negative voltage line
- ➔ : FM signal line
- ➔ : Center Speaker Drive signal line

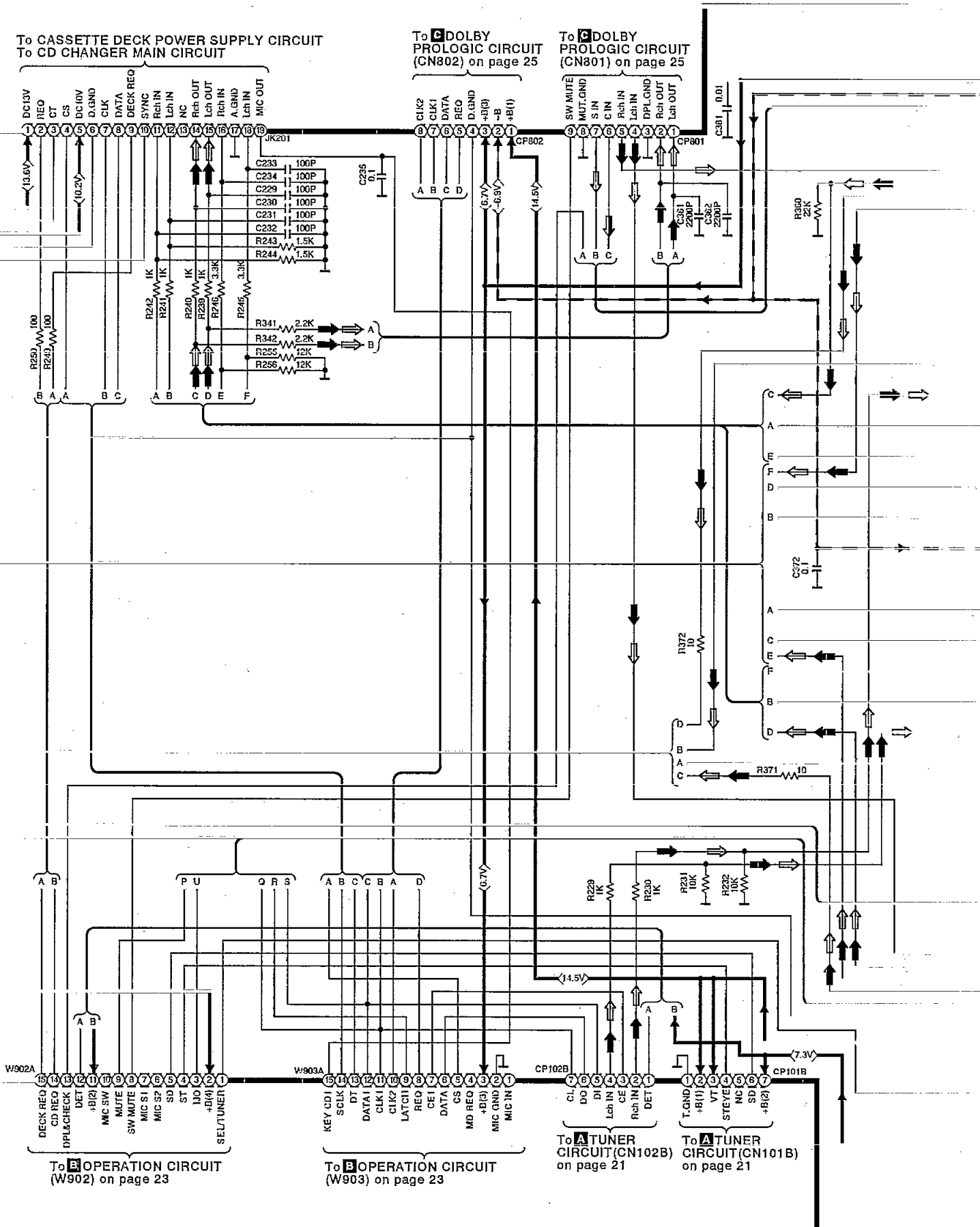

E MAIN CIRCUIT (P.C.Board: on pages 36,37)

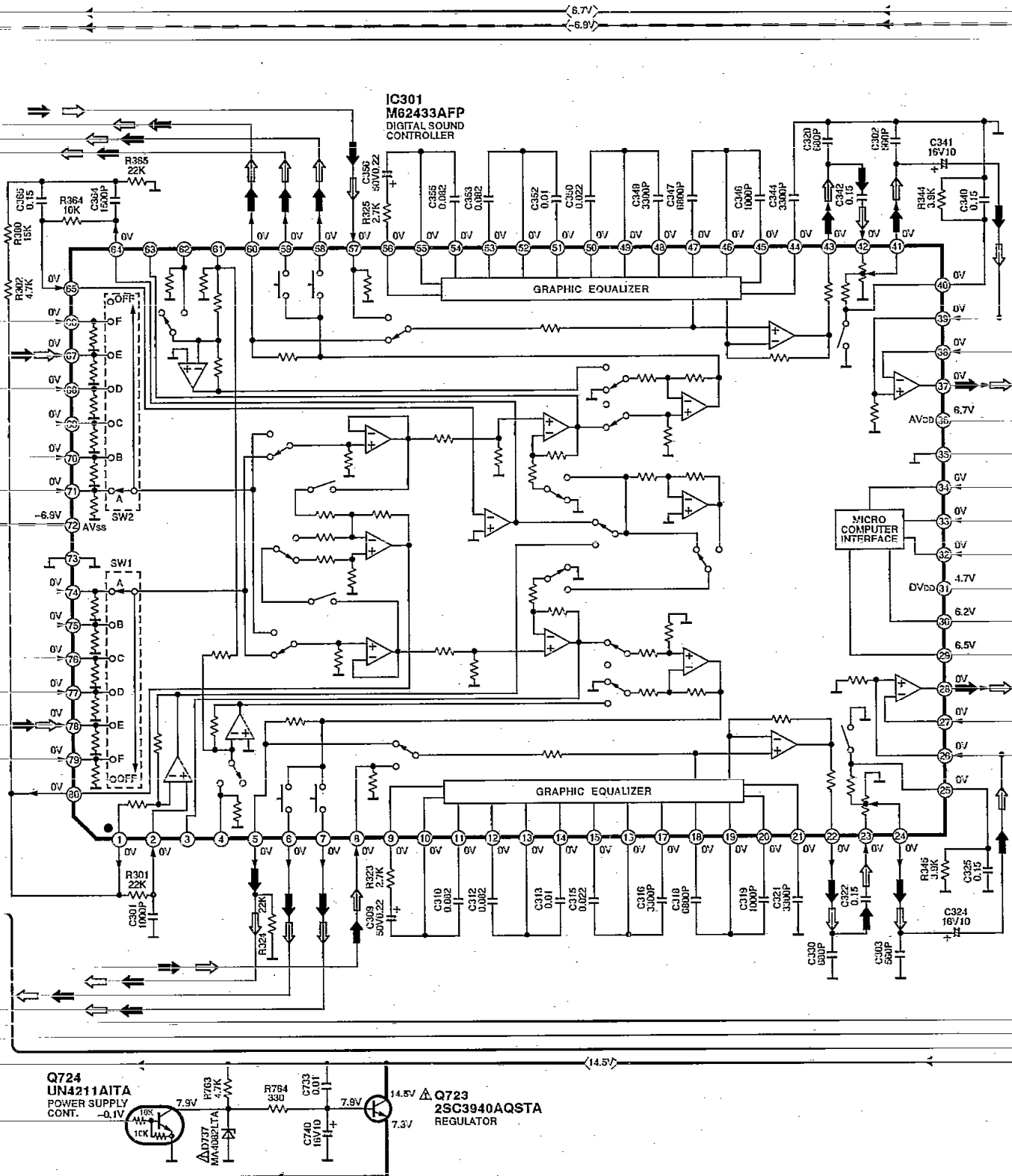

- ➡ : Positive voltage line
- ➡ : AM signal Line
- ➡ : Surround Speaker Drive signal line
- ➡ : Negative voltage line
- ➡ : FM signal line
- ➡ : Center Speaker Drive signal line

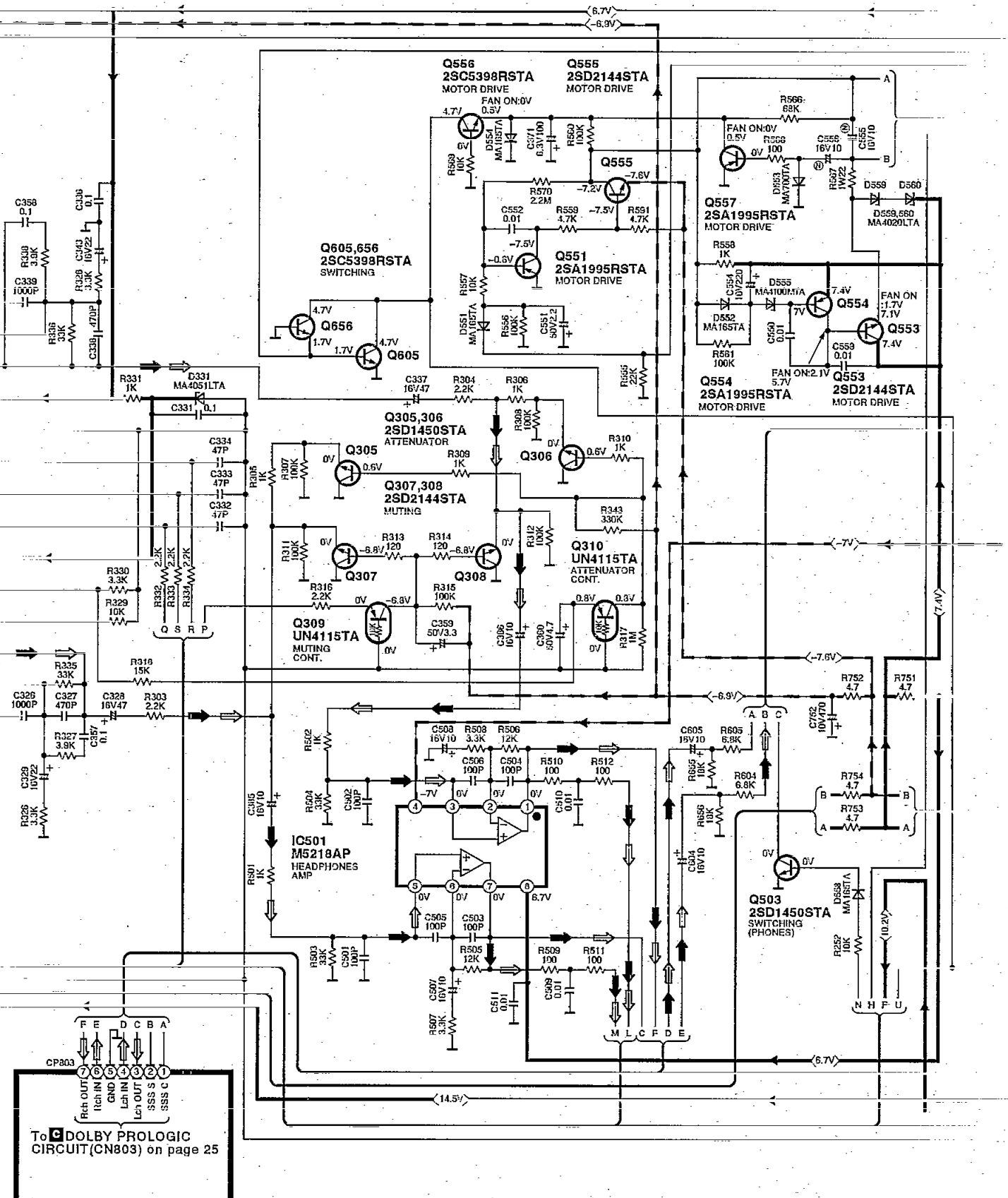

To DOLBY PROLOGIC
CIRCUIT(CN803) on page 25

E MAIN CIRCUIT (P.C.Board: on pages 36, 37)

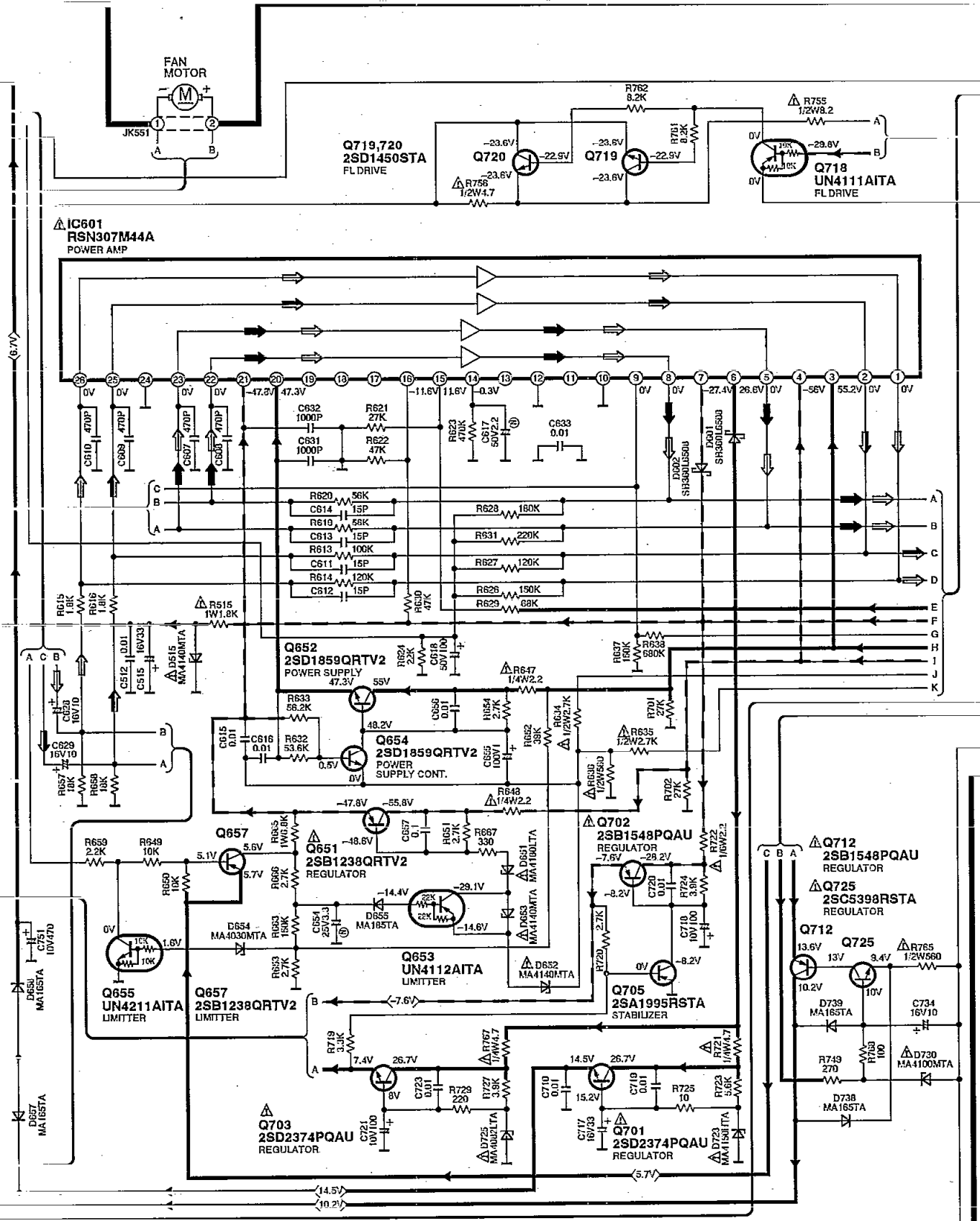

- ➔ : Positive voltage line
- ➔ : AM signal Line
- ➔ : Surround Speaker Drive signal line
- ➔ : Negative voltage line
- ➔ : FM signal line
- ➔ : Center Speaker Drive signal line

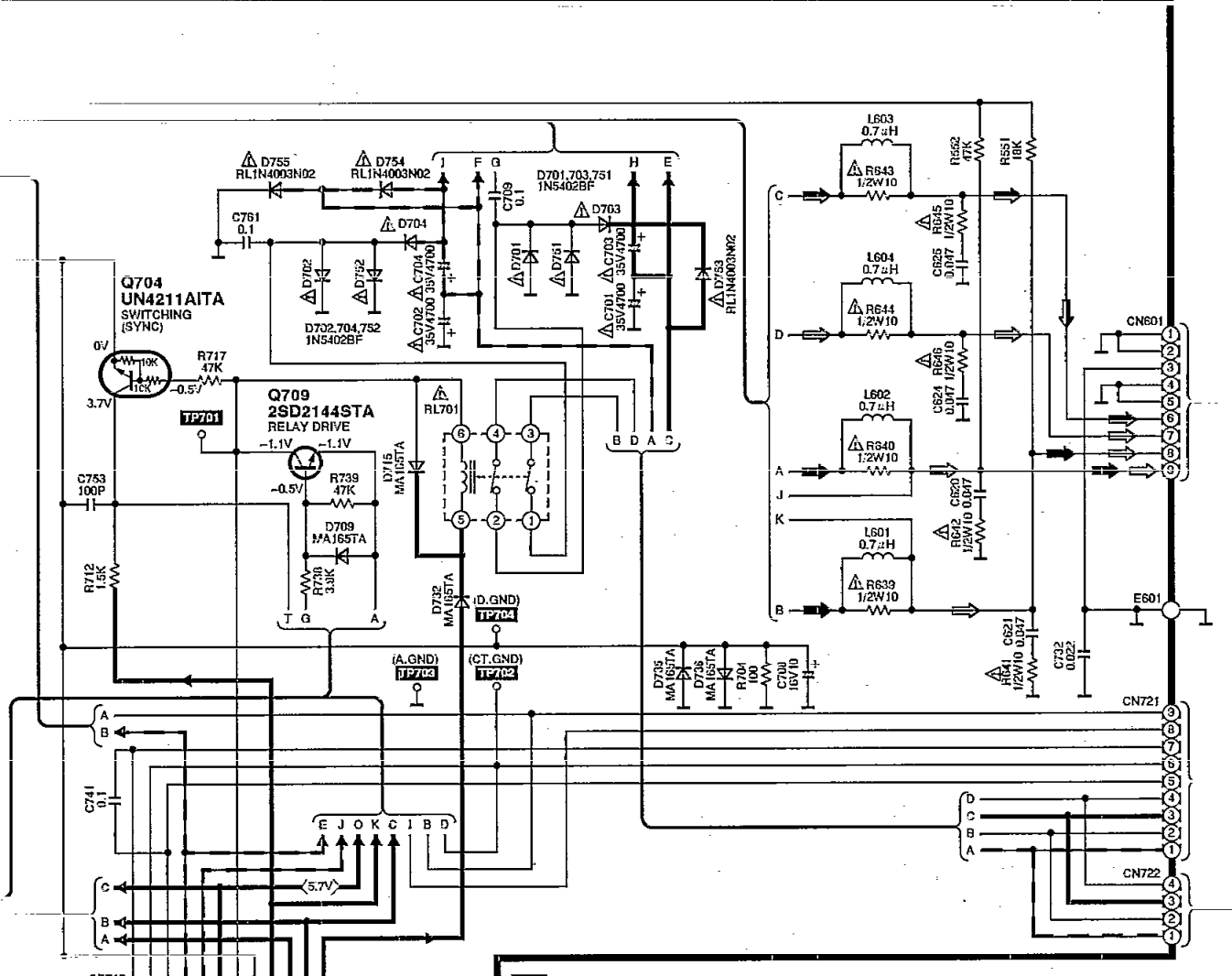

F POWER SUPPLY CIRCUIT (P.C. Board: on page 38)

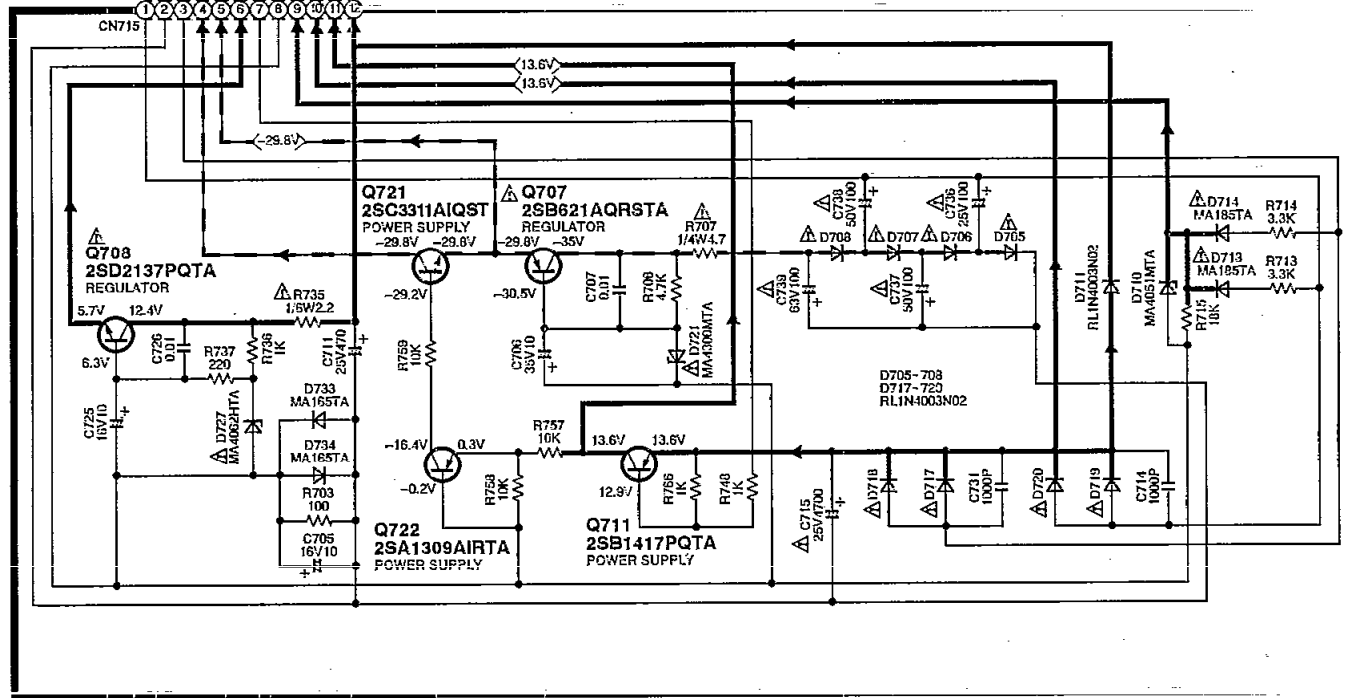

- : Positive voltage line
- : AM signal Line
- : Surround Speaker Drive signal line
- : Negative voltage line
- : FM signal line
- : Center Speaker Drive signal line

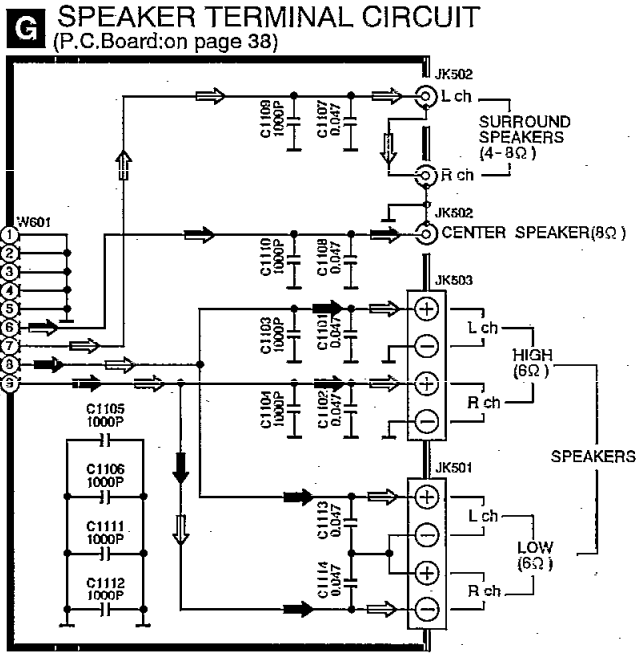

H POWER TRANSFORMER (A) CIRCUIT
(P.C.Board: on page 38)

I POWER TRANSFORMER (B) CIRCUIT
(P.C.Board: on page 38)

