

Service Manual

ORDER NO. AD9903063C2

Tuner/Amplifier SA-EH750

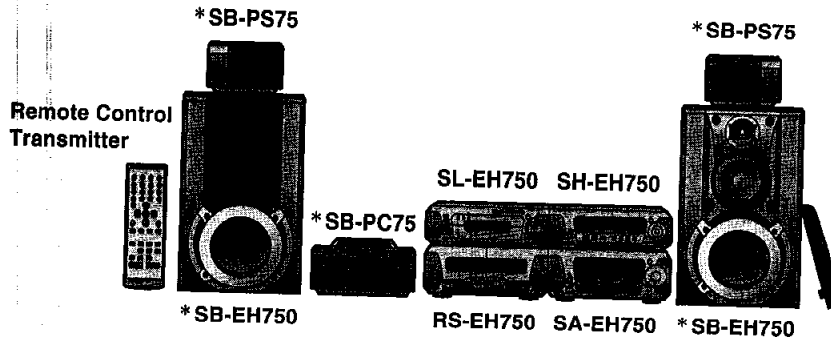

Because of unique interconnecting cables, when a component requires service, send or bring in the entire system.

Colour
(S) Silver Type

Areas
(E) Europe.
(EB) Great Britain.
(EG) Germany,
Italy, France,
Netherlands
and Denmark.
(EP) CIS.

System	SC-EH750
Sound Processor	SH-EH750
Tuner/Amplifier	SA-EH750
CD Changer	SL-EH750
Cassette Deck	RS-EH750
Front Speakers*	SB-EH750
Center Speaker*	SB-PC75
Surround Speakers*	SB-PS75

* : Made in Singapore

Specifications

Amplifier Section

Power output (at HIGH terminal):

DIN 1 kHz, THD 1 %, both channels driven; 2 × 70 W (6 Ω)

RMS 1 kHz, THD 10 %, both channels driven; 2 × 100 W (6 Ω)

Prologic mode (at HIGH terminal):

DIN 1 kHz, THD 1 %

MAIN (both channels driven); 2 × 70 W (6 Ω)

CENTER; 45 W (8 Ω)

SURROUND; 2 × 25 W (8 Ω)

RMS 1 kHz, THD 10 %

MAIN (both channels driven); 2 × 100 W (6 Ω)

CENTER; 60 W (8 Ω)

SURROUND; 2 × 30 W (8 Ω)

PMPO 1 kHz: 3,000 W

(MAIN 6 Ω, CENT. 8 Ω, SURR. 8 Ω)

Total harmonic distortion:

Rated power at 1 kHz; 1 % (6 Ω)

Half power at 1 kHz; 0.1 % (6 Ω)

Load impedance:

MAIN (HIGH/LOW); total impedance 6 Ω

CENTER; 8 Ω

SURROUND; 8 Ω

S.WOOFER:

Center frequency; 70 Hz

LEVEL (VOL-20 dB); MID +8 dB

MAX +12 dB

FM tuner Section

Frequency range: 87.50 – 108.00 MHz (0.05 MHz steps)

Sensitivity: 1.8 μV (IHF usable)

S/N: 26 dB; 1.5 μV

MONO; 70 dB (75 dB, IHF)

Antenna terminal(s): 75 Ω (unbalanced)

AM tuner Section

Frequency range:

522 – 1629 kHz (9 kHz steps)

520 – 1630 kHz (10 kHz steps)

500 μV/m

Sensitivity (S/N 20 dB):

Timer Section

Clock:

Quartz - lock type

Play timer (1 time, daily)

Rec timer (1 time, daily)

Sleep (120 min, 30 min intervals)

1 minute – 23 hours 59 minutes

(1 min intervals)

Function:

Setting (Play/Rec):

General

Power supply:

(E),(EG),(EP) areas;

AC 230 V, 50 Hz

(EB) area;

AC 230 – 240 V, 50 Hz

Power consumption:

205 W

Standby;

Normal;

11 W

ECO mode;

0.6 W

Dimensions (W×H×D):

293×118.5×342.5 mm

Weight:

5.2 kg

Notes: Specifications are subject to change without notice.

Weight and dimensions are approximate.

Total harmonic distortion is measured by the digital spectrum analyzer

⚠ WARNING

This service information is designed for experienced repair technicians only and is not designed for use by the general public. It does not contain warnings or cautions to advise non-technical individuals of potential dangers in attempting to service a product. Products powered by electricity should be serviced or repaired only by experienced professional technicians. Any attempt to service or repair the product or products dealt with in this service information by anyone else could result in serious injury or death.

Technics®

© 1999 Matsushita Electric Industrial Co., Ltd.
All rights reserved. Unauthorized copying
and distribution is a violation of law.

Location of Controls

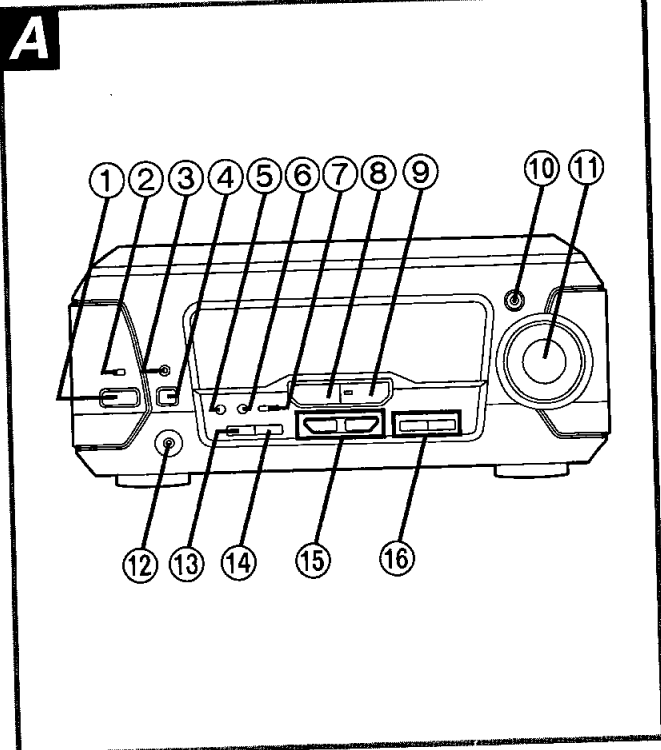

Tuner amplifier

A

- ① **Standby/on switch (⏻/⏻)**
Press to switch the unit from on to standby mode or vice versa. In standby mode, the unit is still consuming a small amount of power.
- ② **Standby indicator (⏻)**
When the unit is connected to the AC mains supply, this indicator lights up in standby mode and goes out when the unit is turned on.
- ③ **Play timer/record timer button and indicator (⌚ PLAY/⌚ REC)**
- ④ **ECO mode button (ECO)**
- ⑤ **Clock/timer, demo button (CLOCK/TIMER, -DEMO)**
- ⑥ **FM mode select button (FM AUTO/MONO)**
- ⑦ **6ch discrete input button (6CH DISCRETE INPUT)**
- ⑧ **Source input select button (INPUT SELECTOR)**
- ⑨ **Tuner/band select button and indicator (TUNER/BAND)**
- ⑩ **Super woofer button and indicator (S.WOOFER)**
- ⑪ **Volume control (VOLUME)**
- ⑫ **Headphones jack (PHONES)**
- ⑬ **Tuning mode select button (TUNING MODE)**
- ⑭ **Set button (SET)**
- ⑮ **Tuning buttons (▲, ▼ TUNING)**
- ⑯ **RDS display mode select buttons (RDS PS-DISP MODE-PTY)**

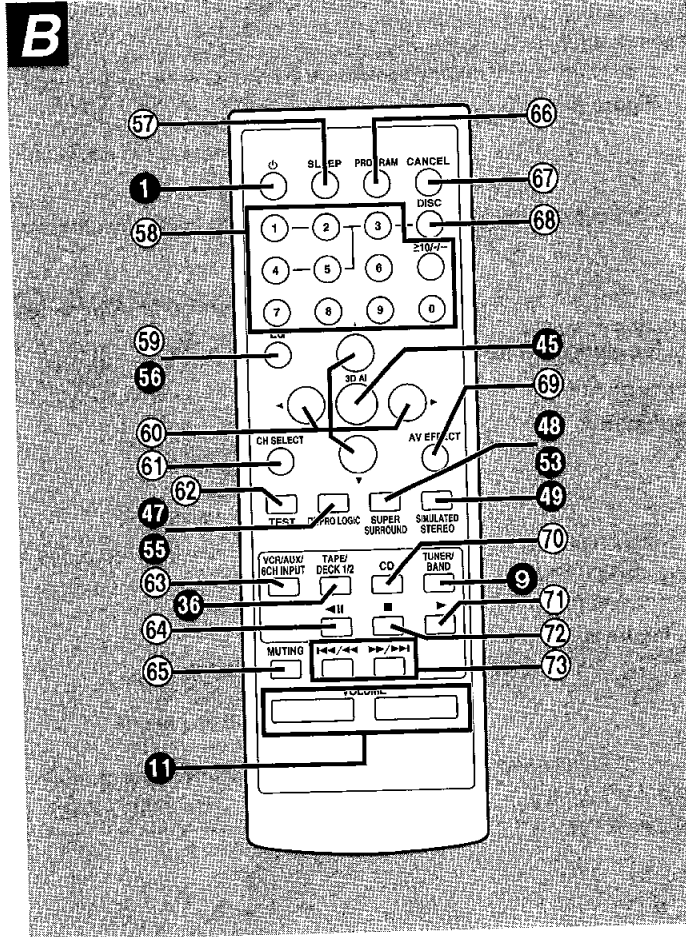

Remote control

B

Buttons as ① function in exactly same way as the buttons on the main unit.

- ⑦ **Sleep timer button (SLEEP)**
- ⑧ **Numeric buttons (1-9, 0, ≥10/-/-)**
- ⑨ **EQ select button (EQ)**
- ⑩ **Cursor buttons (◀, ▲, ▶, ▼)**
- ⑪ **Channel select button (CH SELECT)**
- ⑫ **Test button (TEST)**
- ⑬ **Input selection buttons (VCR/AUX/6CH INPUT)**
- ⑭ **Tape reverse playback/CD pause button (◀/II)**
- ⑮ **Muting button (MUTING)**
- ⑯ **Program button (PROGRAM)**
- ⑰ **Cancel button (CANCEL)**
- ⑱ **Disc select button (DISC)**
- ⑲ **AV effect button (AV EFFECT)**
- ⑳ **CD button (CD)**
- ㉑ **CD play/tape forward playback button (▶)**
- ㉒ **CD/tape stop button (■)**
- ㉓ **CD skip/search, tape fast forward/rewind buttons (I◀◀/◀◀, ▶▶/▶▶I)**

Installation

A

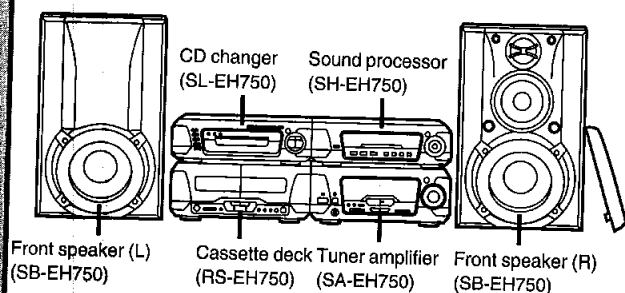

B

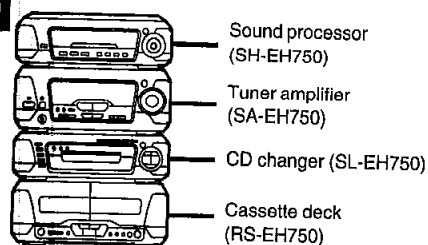

C

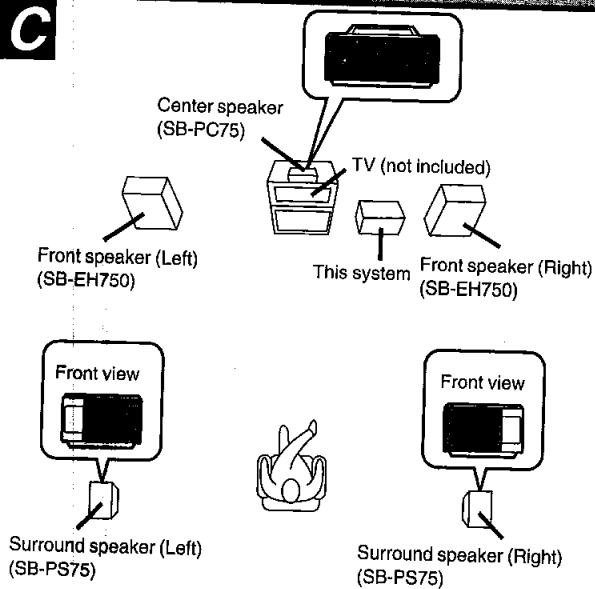

D

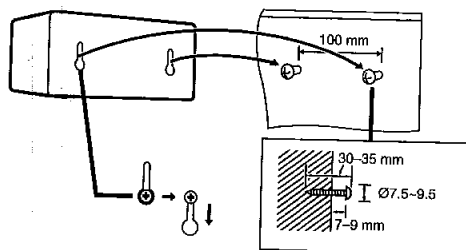

Locating the components

Side-by-side set-up **A**

Stacking **B**

Note

Left and right front speakers are exactly the same.

Placement of center/surround speakers **C**

Center speaker

Place the center speaker above a TV, as close to it as possible.

Surround speakers

We recommend that surround speakers be placed on the side of or slightly behind the listener, and about one meter higher than ear level.

Place the speakers with the Technics logo facing toward the listening position.

However the position should be adjusted to your personal preference, because the effect varies to some degree depending upon the type of music and the music source.

For your reference

Even if you are forced to put your surround speakers on top of your front speakers, this unit still allows you to enjoy surround effects

Attaching to a wall **D**

Set speaker onto screws and slide through bracket to lock into position.

Note

The wall or pillar on which the speaker systems are to be attached should be capable of supporting a weight of 5 kg.

Caution

- Use the speakers only with the recommended system. Failure to do so may lead to damage to the amplifier and/or the speakers, and may result in the risk of fire.
- Do not attempt to attach these speakers to walls using methods other than those described in this manual.

Note

The front and center speakers are made so they can be used in close proximity to the TV, but irregular coloring may result due to how the system is placed. If such distortion occurs, turn off the TV for between 15 and 30 minutes. The demagnetizing function of the TV will eliminate the distortion. If the irregular coloring is still visible, then move the speaker further away from the TV.

Connections

To prepare the AM loop antenna wire and speaker cords, twist the vinyl cover tip and pull off.

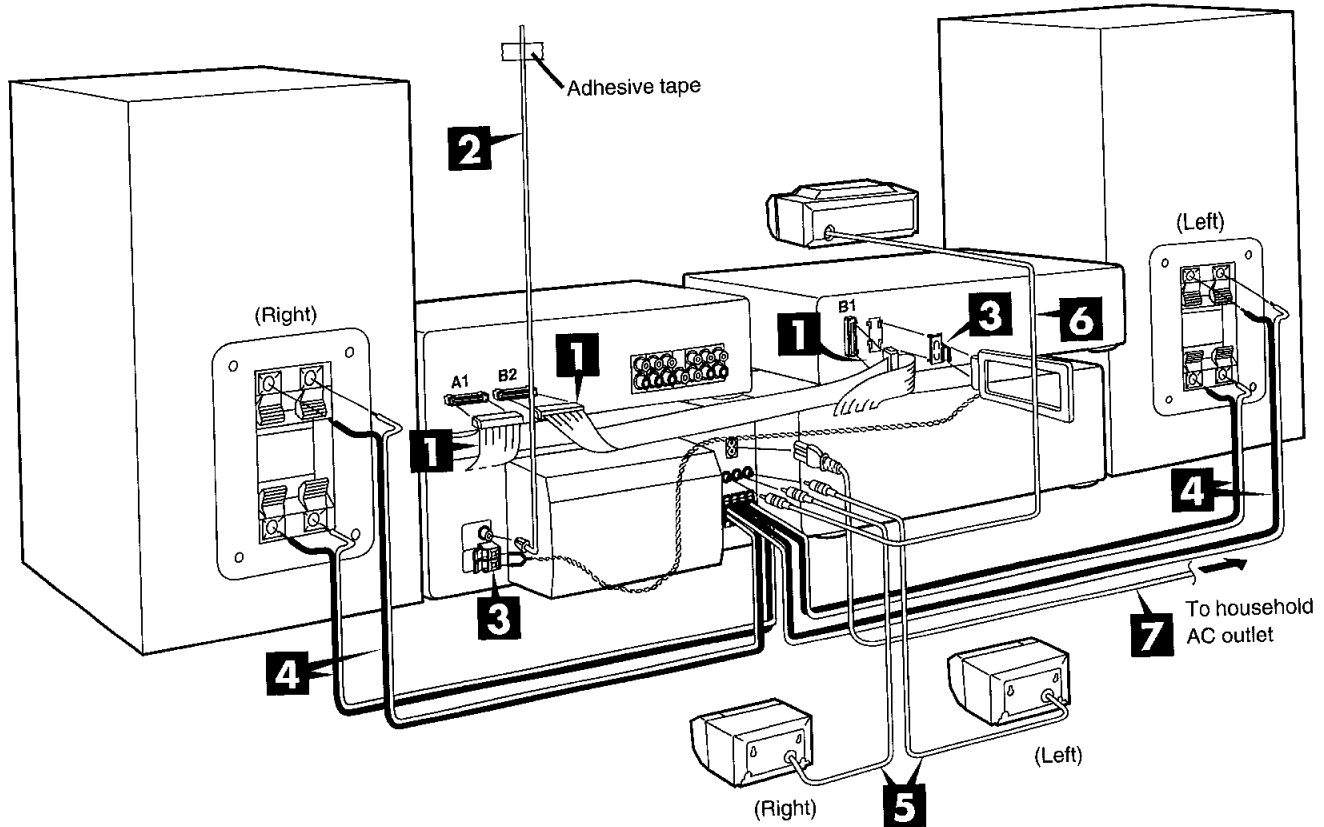
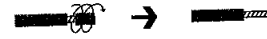

<p>1</p> <p>To connect cables</p> <p>Connector</p> <p>White line</p> <p>To unplug cables</p> <p>Hold the connector from both ends and pull it out.</p>	<p>3</p> <p>1</p>	<p>4</p> <p>Tuner amplifier side</p>
<p>2</p> <p>FM ANT 75Ω</p>	<p>2</p>	<p>Speaker side</p>

■ Preparing the Remote Control

Battery installation

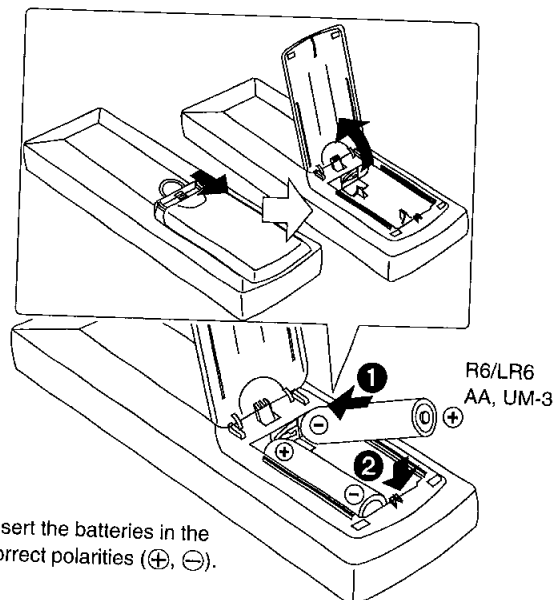

Insert the batteries in the correct polarities (+, -).

- Do not mix old and new batteries, or batteries of different types (manganese and alkaline, etc.).
- Never subject batteries to excessive heat or flame; do not attempt to disassemble them; and be sure they are not short-circuited.
- If the remote control is not to be used for a long period of time, remove the batteries and store them in a cool, dark place.
- Do not attempt to recharge alkaline or manganese batteries.
- Do not use rechargeable type batteries.

Correct method of use

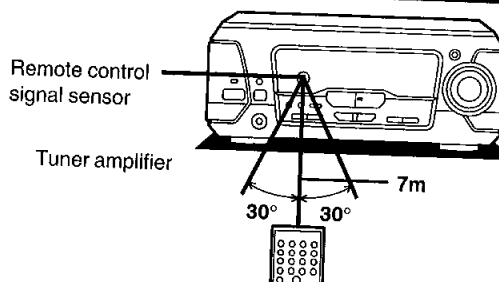

- Aim the remote control's transmission window toward the unit's sensor. Avoid any obstacles.
- Be sure the transmission window and the unit's sensor are free from dust. Excessive dust might affect its performance.
- This unit may not operate correctly if direct sunlight or another strong light source strikes the receiving sensor of this unit. If there is a problem, place the unit away from the light source.
- Never place heavy items on top of the unit.
- Do not disassemble or reconstruct the unit.
- Do not spill water or other liquids into the unit.

1 Connect the flat cables.

1. Connect the shorter flat cable from the tuner amplifier to terminal A1 on the sound processor.
2. Connect the longer flat cable from the cassette deck to terminals B1 and B2.

After connection:

Keep cables as flat against the back of the unit as possible.

2 Connect the FM indoor antenna.

Tape the antenna to a wall or column, in a position where radio signals are received with the least amount of interference.

3 Connect the AM loop antenna.

1. Attach the antenna holder to the rear panel of the CD changer. Then clamp the antenna into the antenna holder.
2. Connect the antenna terminal to the rear panel of the tuner amplifier.

Note

To minimize noise pickup, bundle the loop antenna cord using tape or the like to keep the flat cables away from the AM loop antenna cord.

4 Connect the right (R) and left (L) front speaker cables.

Connect each end of the speaker cables to the terminal lever of the same color.

Use only the supplied front speakers.

The combination of the main unit and front speakers provide the best sound. Using other front speakers can damage the unit and sound quality will be negatively effected.

Note

- To prevent damage to circuitry, never short-circuit positive (+) and negative (-) speaker wires.
- Be sure to connect only positive (red or gray) wires to positive (+) terminals and negative (black or blue) wires to negative (-) terminals.

5 Connect the surround speaker cables.

6 Connect the center speaker cables.

(United Kingdom only)
BE SURE TO READ THE CAUTION FOR AC MAINS LEAD BEFORE PROCEEDING TO STEP 7.

7 Connect the AC mains lead.

Insertion of Connector

Even when the connector is perfectly inserted, depending on the type of inlet used, the front part of the connector may jut out as shown in the drawing.

However there is no problem using the unit.

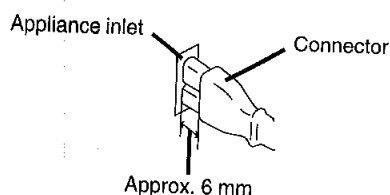

For your reference

Information you enter into the unit's memory, except for the time, remains intact for up to two weeks after the mains lead is disconnected.

External Unit Connections

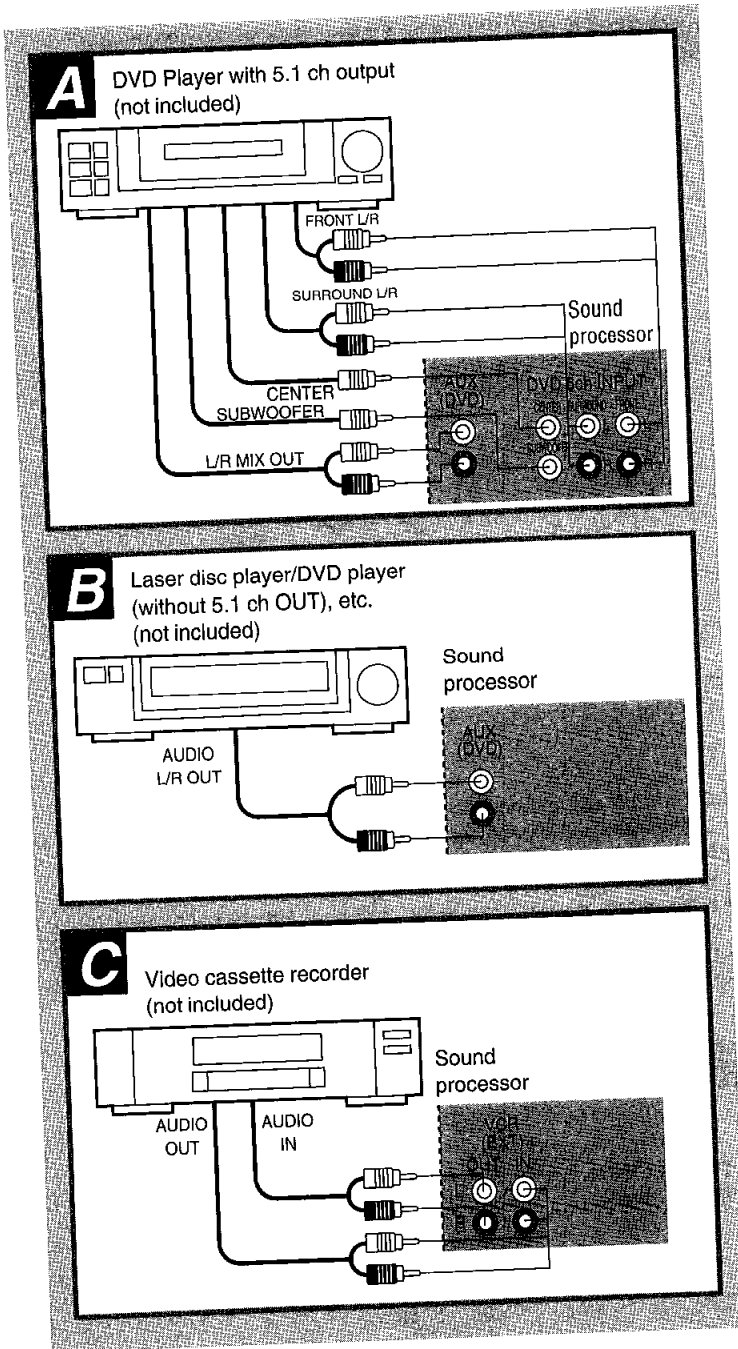

- Make sure that the power supply for all components has been turned off before making any connections.
- For details, refer to the operating instructions of the units which are to be connected.
- All peripheral components and cables sold separately.

Stereo connection cable (not included)



Video connection cable (not included)



A DVD player with 5.1 ch output

This unit has the input terminals for 5.1 channel surround systems but it does not have the decoders necessary to play them back. The DVD player should have these decoders and 5.1 channel output.

The front speakers have subwoofers, but it is possible to connect another subwoofer (not included) to the SUBWOOFER OUT terminal on the back of the sound processor to further enhance the surround experience available with 5.1 channel input.

B Laser disc player/DVD player (without 5.1 ch OUT), etc.

This unit has Dolby Pro Logic circuitry. If the audio output of video equipment is connected to the AUX terminal of this unit, the sound will be reproduced with the same powerful stereophonic effects found in movie theaters.

C Video cassette recorder

You can enjoy only sound of the video cassette recorder.

Optional Antenna Connections

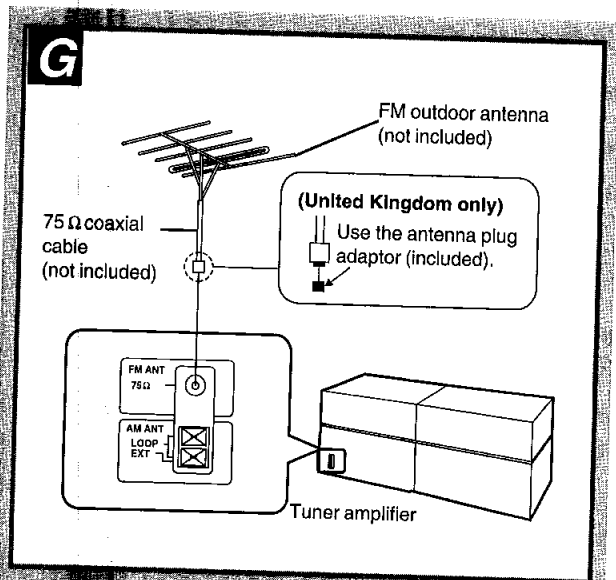

You may need an outdoor antenna if you use this system in a mountainous region or inside a reinforced-concrete building, etc.

FM outdoor antenna (not included) **G**

AM outdoor antenna (not included) **H**

Connect the outdoor antenna without removing the AM loop antenna. Run 5 to 12 m of vinyl-covered wire horizontally along a window or other convenient location.

Note

When the unit is not in use, disconnect the outdoor antenna to prevent possible damage that may be caused by lightning. Never use an outdoor antenna during an electrical storm.

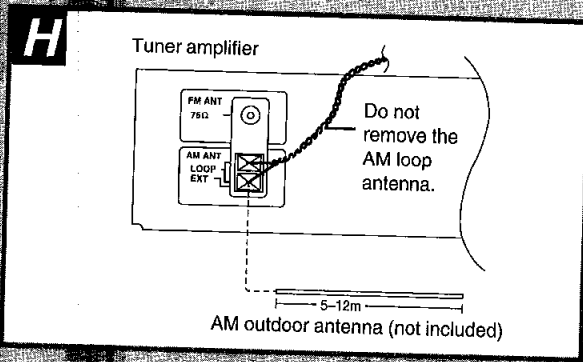

Turning the Demo Function Off (DEMO)

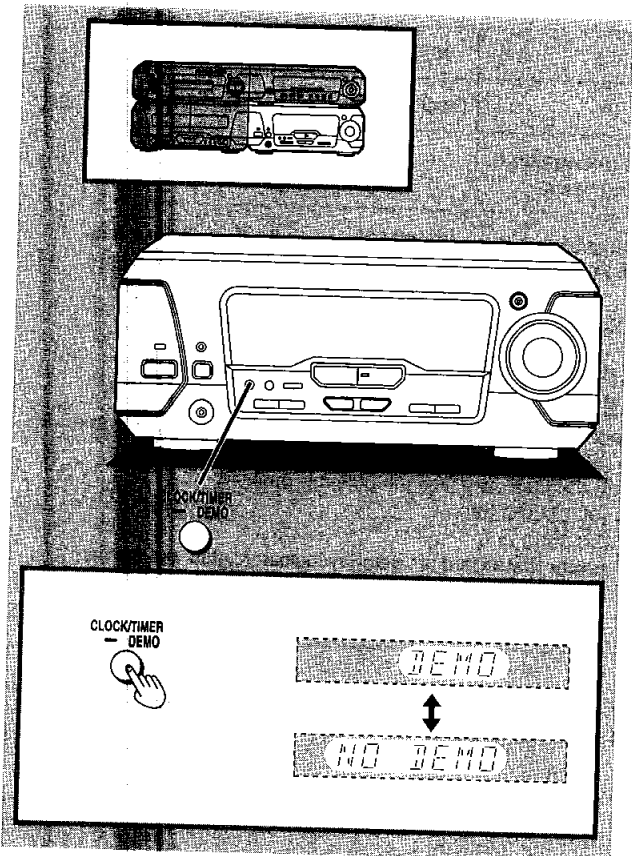

If the clock has not been set, a demonstration of the display is shown when the unit is off.

This function is set to on at the time of purchase.

To get the most from the ECO mode, turn the demo function off.

Press and hold [CLOCK/TIMER, -DEMO] until "NO DEMO" is displayed.

Every time you press and hold the button;

NO DEMO (off) \rightleftarrows DEMO (on)

Note

Once the clock has been set the demo cannot be turned on when the unit is off.

■ Setting the Time

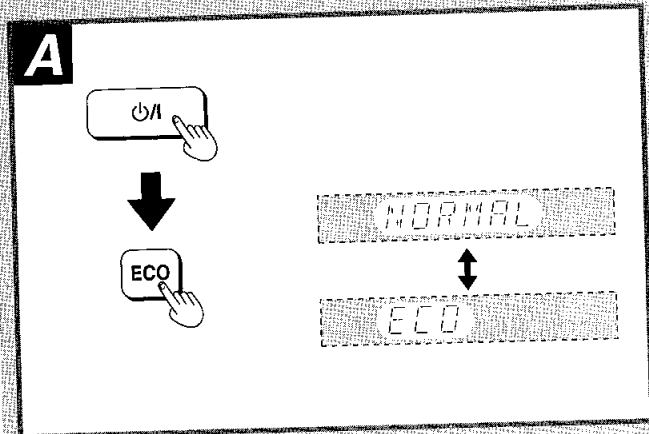
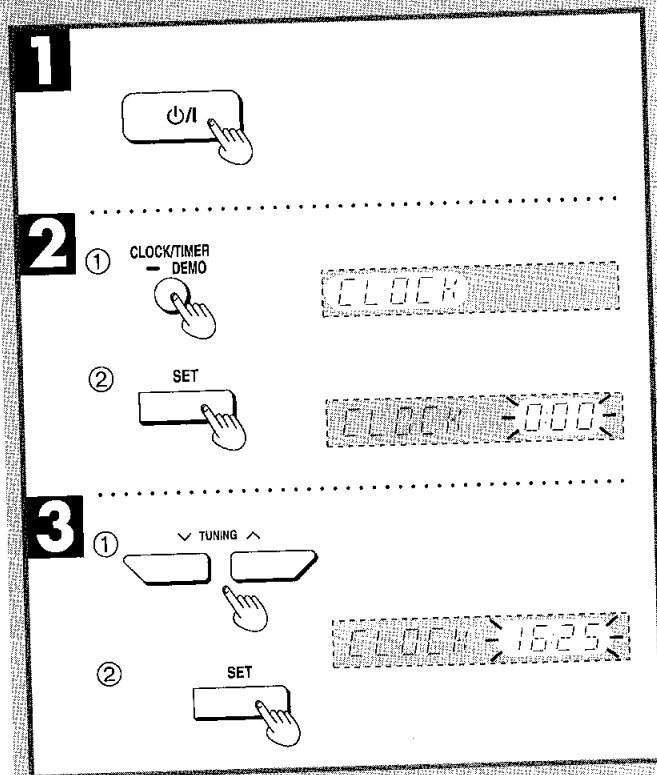
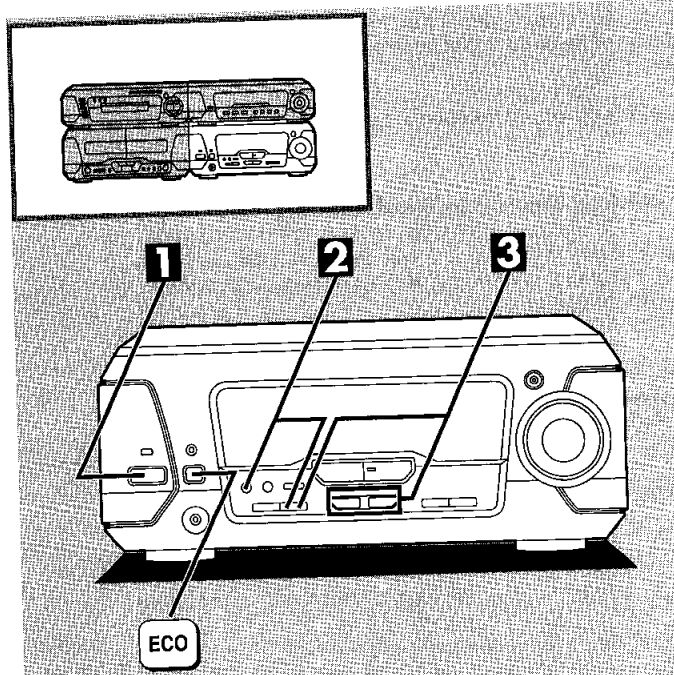

This is a 24-hour display clock.

The figure shows how to set the time for 16:25.

- 1** Press [⏻/⏻] to turn the unit on.
- 2** **1** Press [CLOCK/TIMER, -DEMO] to show "CLOCK".
Every time you press the button;
CLOCK → ⏻ PLAY → ⏻ REC → Original display
- Within 5 seconds:
2 Press [SET].
- 3** **1** Press [TUNING (∨ or ∧)] to set the present time on the display.
The time display can be changed in one minute units by tapping the buttons, and quickly by holding down the buttons.
- 2** Press [SET].
The display will return to the previous display after about 3 seconds.

To display the clock:

Press [CLOCK/TIMER, -DEMO].

The time is shown for about five seconds.

The time is shown constantly when the unit and ECO mode are off.

■ ECO mode **A**

When this mode is used the power consumed when the unit is switched to standby mode reduces from a maximum of 11 W to 0.6 W

This mode is set to on at the time of purchase.

	NORMAL (off)	ECO (on)
Display	Clock display, etc.	Blank
Power consumption in standby mode	11 W	0.6 W

The demonstration is shown if DEMO is on, regardless of the condition of the ECO mode. Turn DEMO off if ECO is used.

Turning ECO on and off:

Press [⏻/⏻] to turn the unit on.

Press [ECO].

The current ECO mode is displayed. Press again to change the mode.

The display changes each time the button is pressed:

NORMAL (off) ↔ ECO (on)

When ECO is on:

When the power is switched off, standby indicator lights, but the display panel remains blank.

Note

When the unit is off, the mode can be switched from NORMAL to ECO, but not the other way.

Listening to Compact Disc

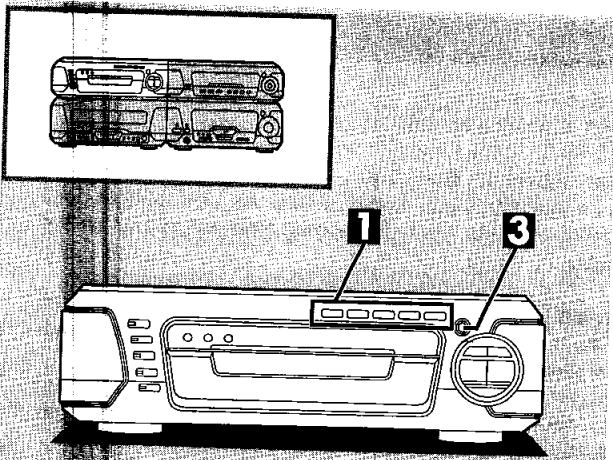

Always stop the changer before loading or changing CDs. You cannot change CDs while a disc is playing.

How to load CDs

- 1** Press [DISC 1]–[DISC 5], whichever you want to open.
- 2** Set the CD in the tray.
Repeat steps **1** and **2** to load the other trays.
- 3** Press [**▲** OPEN/CLOSE].
The tray will close and the disc No., number of tracks and total playing time will be shown on the display.

To prevent damage

Always observe the following points.

- Load only 1 CD per tray. **A**
- Load CDs as shown in figure **B**.
An adapter is not needed with 8 cm CDs (singles).
- Set the system on a flat, level surface.
Do not set it on top of magazines, inclined surfaces, etc.
- Do not move the system while trays are opening/closing, or when loaded.
- Always unload all trays before moving the system.
- Do not put anything except CDs in trays.
- Do not use cleaning CDs or CDs which are badly warped or cracked.
- Do not use CDs with poorly attached labels or stickers. Adhesive protruding from underneath stickers or left over from peeled off stickers can cause the system to malfunction.
- Do not use irregular shaped CDs. **C**

1

2

3

Disc number	Number of tracks	Total playing time
DISC 1	16	45:28

A

B

8cm CD		
12cm CD		

C

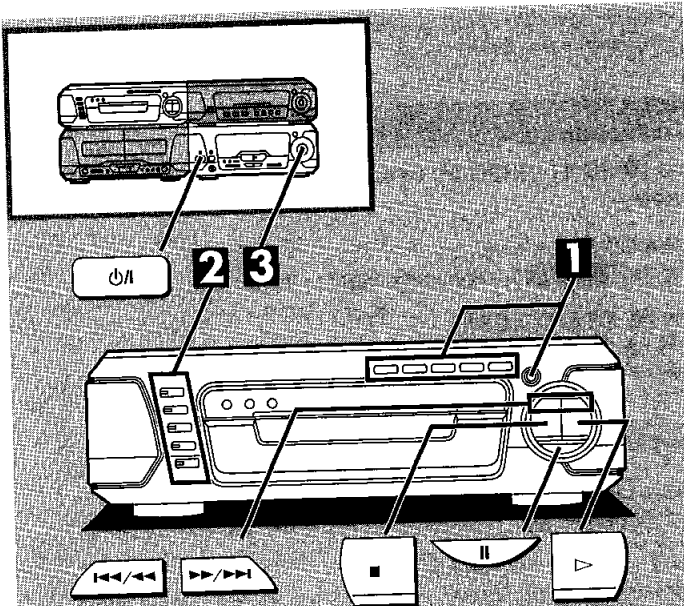

1

DIRECT OPEN
DISC 1 DISC 2 DISC 3 DISC 4 DISC 5

Disc number Total number of tracks Total playing time

DISC 1 16 45:28

OPEN/CLOSE

2

DISC

1
2
3
4
5

Track number Elapsed play time

3 00:01

3

VOLUME

UP

DOWN

VOL -48.23

Sequential play

Preparation:

Press [⏻] to turn the unit on.

1 Insert CDs in the trays.

When the "CD" input source is selected, disc number, total number of tracks, and total playing time will appear on the display.

2 Press [1]–[5] to select the disc you want.

(If the desired CD is indicated on the display panel the same operation can be accomplished by pressing [▷].) Play will start from the first track on the disc shown on the display, and will continue until the last track of the final disc (see below).

3 Adjust the volume.

To stop the disc:

Press [■].

To temporarily stop the disc:

Press [⏸]. The play indicator flashes green. To play again, press [▷].

Skipping tracks backward and forward:

Press [⏮/◀] to skip backward. Press [▶/⏭] to skip forward.

Searching through tracks during play:

Press and hold [⏮/◀] to search backward. Press and hold [▶/⏭] to search forward.

What is meant by "final disc"?:

For example, if play starts from disc 4, disc 3 will be the "final disc".

Order of progression:

Disc 4 → 5 → 1 → 2 → 3

When "NO DISC" display appears:

It indicates that a CD has not been installed.

For your reference:

If you press [▷] instead of [▲ OPEN/CLOSE] after inserting a CD, the tray will close and play will start directly from the track 1.

Note

- During random play, you cannot skip to tracks which have already been played.
- During program play or random play, you cannot search-forward/backward over tracks.
- During program play, skipping is in always in the programmed order, whether forward or backward.

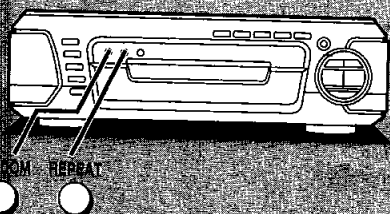
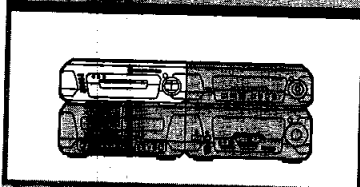
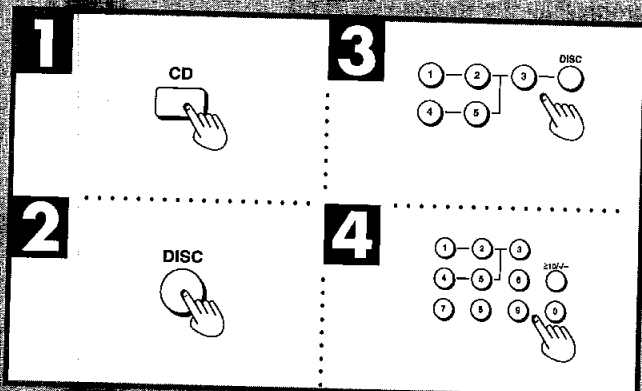
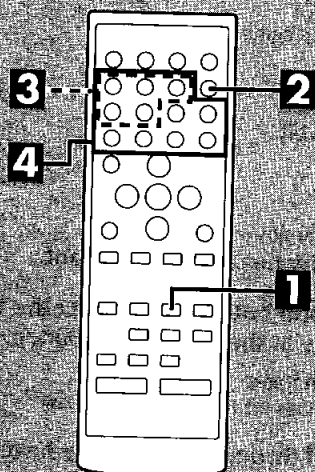
A**B**

REPEAT

**C**

RANDOM

**Direct access play****A**

Direct access allows you to start sequential play from a specific track to the last track of the final disc.

by remote control only

- 1** Press [CD].
- 2** Press [DISC].
- 3** (within 10 seconds or so)
Press [1]–[5], whichever disc you want.
- 4** Press the numeric button(s) to select the desired track number.

To select a two-digit track:

Press [≥ 10 /--] and then the two numbers you want within 10 seconds or so.

Repeat play**B**

This function repeats the play of all tracks of all discs.

Press [REPEAT] before or during play.

To cancel repeat play:

Press [REPEAT] once again.

To repeat only your favorite track(s)

1. Program the track(s) you want.
2. Press [REPEAT] and make sure "↻" is displayed.
3. Press [▷]. Play will start.

Random play**C**

This function automatically selects a sequence of tracks to be played in random order.

Press [RANDOM].

Random play will start.

Play will stop automatically when all tracks on all of the discs finish playing randomly.

To cancel random play:

Press [RANDOM] once again.

For your reference:

In the program play mode, the programmed tracks will be played randomly.

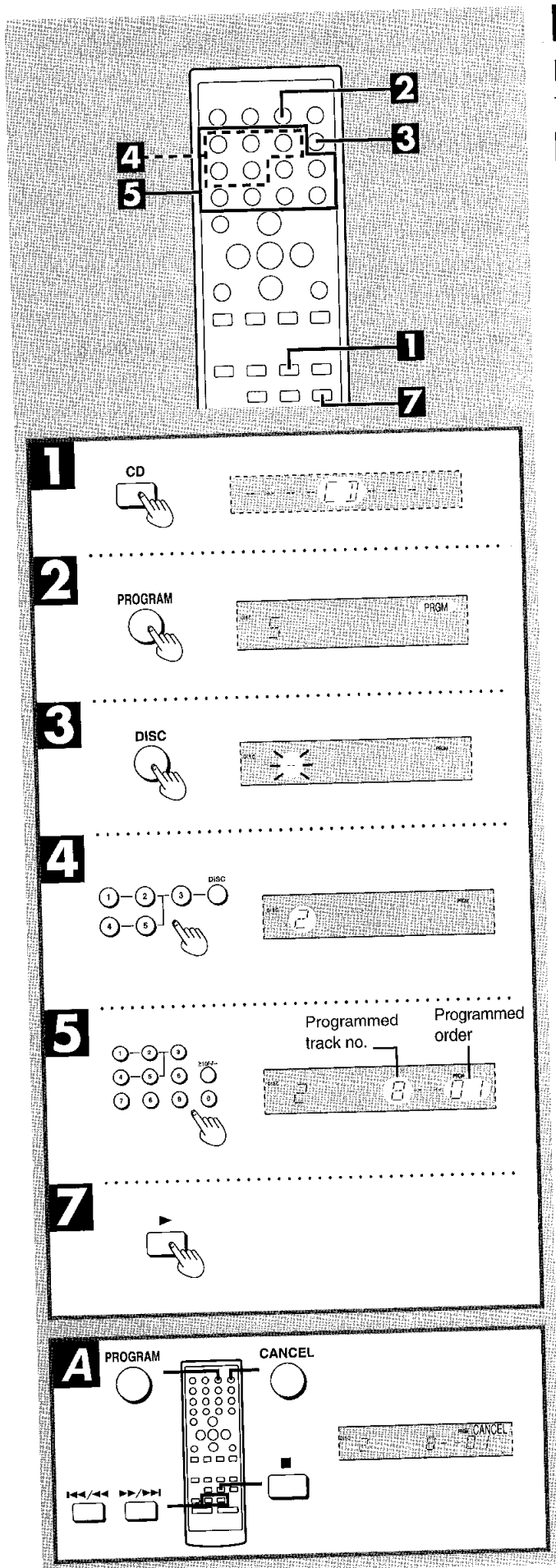

Program play

by remote control only

This function allows you to program up to 24 tracks.

- 1** Press [CD].
- 2** Press [PROGRAM].
- 3** Press [DISC].
- 4** (within 10 seconds or so)
Press [1]–[5] whichever disc you want.
- 5** Press the numeric button(s) to select the track you want to play in the desired sequence.

To select a two-digit track:
Press [≥ 10 /--] and then the two numbers you want.
- 6** Repeat steps **3** through **5** until you have programmed all the tracks you want.
- 7** Press [▶].
Play will start in the programmed sequence.
Play will stop automatically when all the programmed tracks have been played.

To cancel program play mode:

Press [PROGRAM].

"CLEAR" will appear on the display for approximately 1 second and all the programmed tracks will be cancelled.

When "FULL" appears:

The number of programmed tracks is limited to 24. No further tracks can be programmed.

When "--:--" appears:

The total playing time of the programmed tracks has exceeded 99 minutes 59 seconds, or you tried programming a track which is numbered 25 or more, or you tried programming a disc not in playing position. In any case, you can still program and play discs.

You can do the following during program play. **A**

• Check program contents.

1. Press [CANCEL]. "CANCEL" will light.
2. Press [◀/◀◀] or [▶▶/▶]. Every time you press one of the buttons, the track and program No. are shown on the display.
3. After the total playing time appears on the display, press [CANCEL]. "CANCEL" goes out.

• Add to the program.

Repeat steps **3** through **5**.

• Cancel entries.

A specific track only:

- ① Press [CANCEL]. "CANCEL" will light.
- ② Press the numeric button(s) of the track you want to cancel, or press [◀/◀◀] or [▶▶/▶] to select the track you want to cancel and then press [CANCEL].
- ③ Press [CANCEL] once again. "CANCEL" goes out.

All tracks:

Press [PROGRAM], or press [■] while play is stopped.

For your reference:

To program the track you are listening to:

If you press [PROGRAM] during playback, the program mode will engage and the current track will be automatically recorded as program No. 1.

■ Boosting the Super Woofer **A**

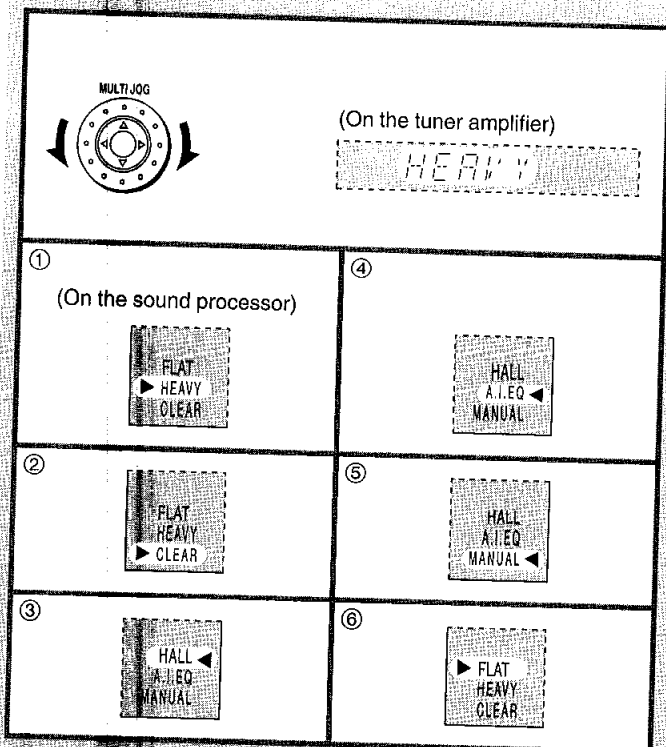
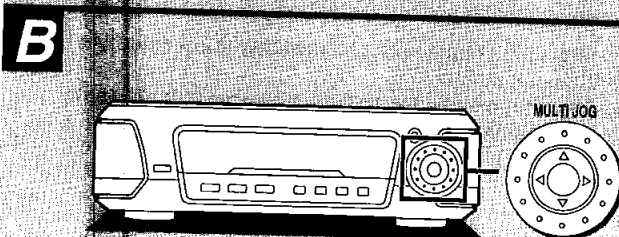
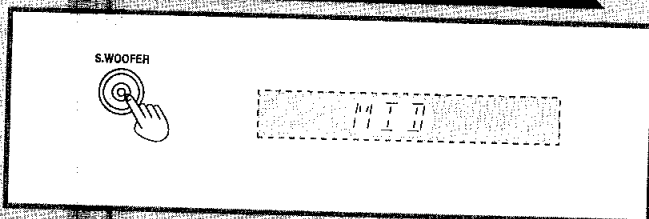
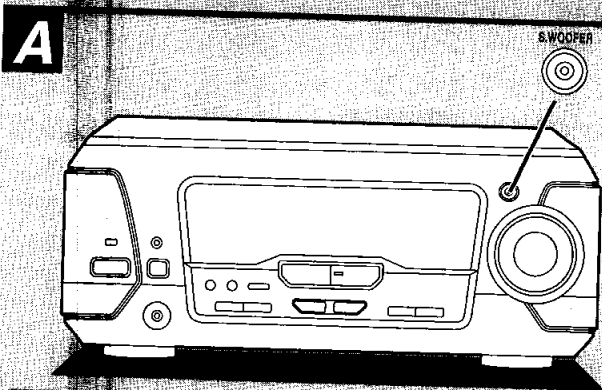
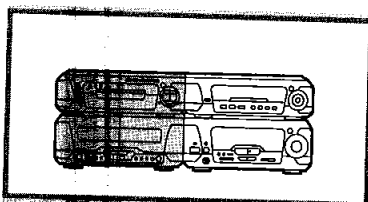

Press [S. WOOFER].
[S. WOOFER] lamp lights.

- When listening to the sound through the speakers:
MID (medium) → MAX (high) → Light off (OFF)
- When listening to the sound through the headphones:
Light on (ON) ↔ Light off (OFF)

To cancel

Press [S. WOOFER] to select OFF.

■ Using the Built-in Sound Quality/ Sound Field Settings **B**

Turn [MULTI JOG] to select the sound quality or sound field.

When [MULTI JOG] is turned clockwise the settings are selected in the following sequence.

- ① **HEAVY (sound quality)**
Select this when playing rock or other kinds of music that sound better with an added punch.
- ② **CLEAR (sound quality)**
Select this for jazz or other kinds of music for which clarity in the treble range is desired.
- ③ **HALL (sound field)**
Select this to add an expansiveness to the sound to produce the atmosphere of a great concert hall.
- ④ **AI EQ**
- ⑤ **MANUAL**
- ⑥ **FLAT**
The original display is restored on the display panel in about 5 seconds.

To release the equalizer

Turn [MULTI JOG] to select "FLAT".

■ Varying the Sound Quality with the Manual Equalizer (Manual EQ)

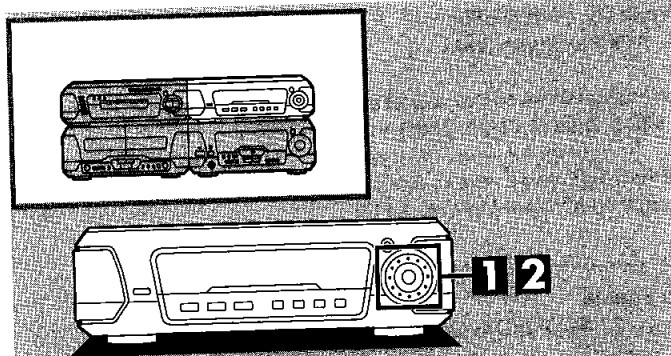

1 Turn [MULTI JOG] to select "MANUAL".

When [MULTI JOG] is turned clockwise, the settings are selected in the following sequence.

- ① HEAVY
- ② CLEAR
- ③ HALL
- ④ AI EQ
- ⑤ **MANUAL**
- ⑥ FLAT

2 Adjust the sound quality.

- ① ← → direction: For selecting the range of the sound to be adjusted

Characteristics of each sound range

- Under 100 Hz: Super woofer range
- Around 315 Hz: Bass to midrange
- Around 1 kHz: Midrange
- Around 3.15 kHz: Midrange to treble
- Above 10 kHz: Treble

- ② ↓ ↑ direction: For adjusting the level

Repeat steps ① and ② to set the desired sound quality.

The original display is restored on the display panel in about 5 seconds.

To release the equalizer

Turn [MULTI JOG] to select "FLAT".

Note

- The sound quality setting is stored automatically. It is recalled when "MANUAL" is next selected.
- All recordings are performed at the flat setting even if an alternative sound quality setting has been selected.

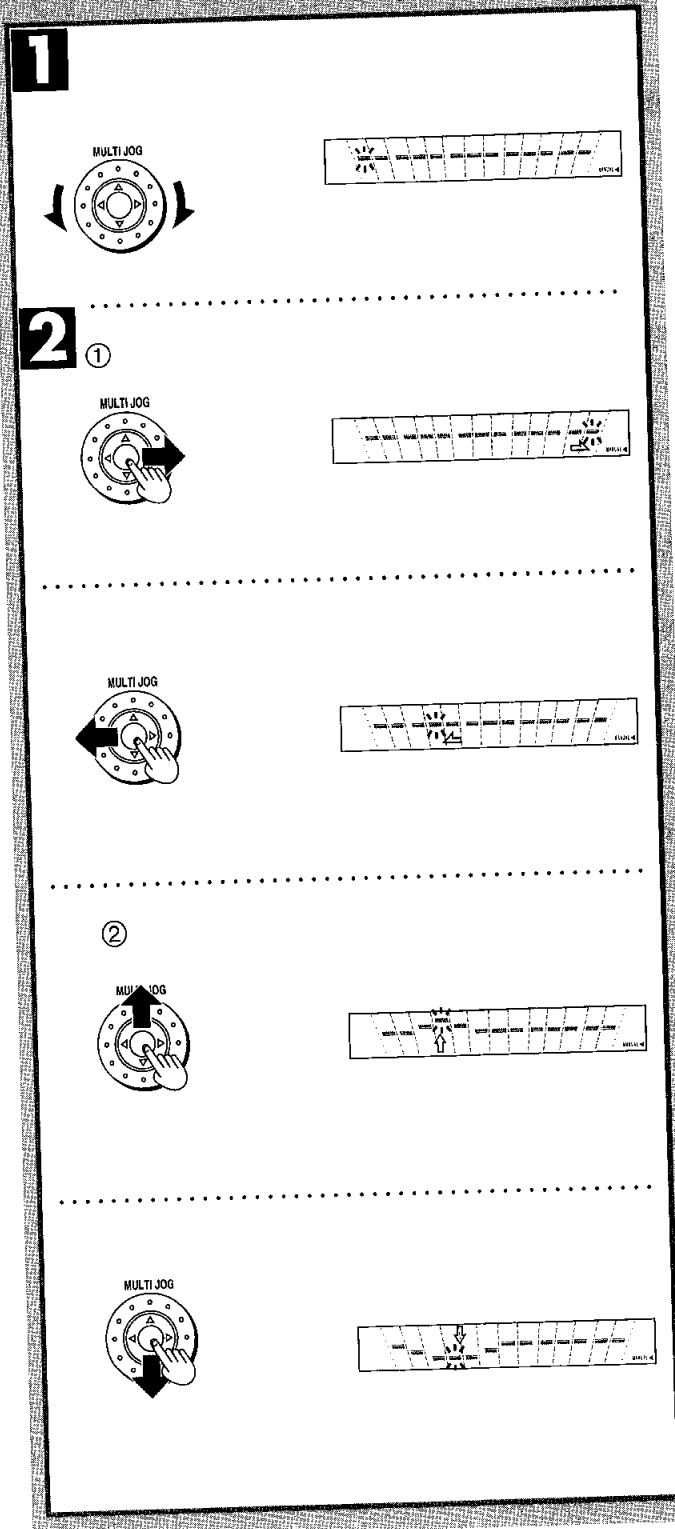

■ Varying the Sound Quality with the Acoustic Image (AI) Equalizer (3D AI EQ)

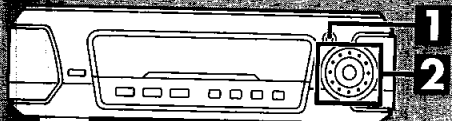

It is possible to use the acoustic image equalizer (AI EQ) together with the surround effect to create your own sound effect. The AI EQ equalizer uses the SOFT, SHARP, HEAVY and LIGHT sound quality coordinates to achieve subtle sound quality settings with ease.

1 Press [3D AI EQ] to adjust the surround level.

Everytime you press the button;
AI EQ → 3D AI 1 → 3D AI 2

2 Adjust the sound quality.

① ← → direction: SOFT–SHARP setting

② ↓ ↑ direction: LIGHT–HEAVY setting

Repeat steps ① and ② to set the desired sound quality.

The original display is restored on the display panel in about 5 seconds.

To release the equalizer

Turn [MULTI JOG] to select "FLAT".

Note

- The sound quality setting is stored automatically. It is recalled when "AI EQ" is next selected.
- All recordings are performed at the flat setting even if an alternative sound quality setting has been selected.
- 3D AI 1 and 3D AI 2 cannot be selected while the 6CH DISCRETE INPUT, DOLBY PRO LOGIC, SUPER SURROUND, SIMULATED STEREO and VIRTUAL DOLBY SURROUND modes are on.

1

3D AI EQ



(On the tuner amplifier)

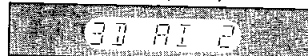

(On the sound processor)



2

①

MULTI JOG

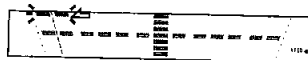

MULTI JOG



②

MULTI JOG



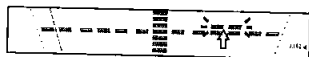

MULTI JOG



■ Surround Systems

• Select the surround mode appropriate to the source you are using. Read the following explanations to aid your selection.

Surround system	Features	Recognizing the sound sources and software that can be used			
6CH DISCRETE INPUT	<ul style="list-style-type: none"> • Dolby Digital is a discrete 5.1 channel surround system developed for cinema use. The sound signals in Dolby Digital format are compressed to 1/10 their original size, allowing an entire movie to be recorded on a single DVD. • You will need a DVD player that has a built in decoder to enjoy DVDs with this unit. • Connect a subwoofer (not included) to SUBWOOFER OUT terminal on the rear panel of the sound processor to increase the effect. 	<p>Discs with the following mark are recorded in Dolby Digital:</p> <ul style="list-style-type: none"> • DVD • Laser Disc 			
DOLBY PRO LOGIC	<ul style="list-style-type: none"> • This system was developed to get a better sense of presence from sources encoded with Dolby Surround. • The feeling of position has been improved by the addition of a separate center speaker channel. • This unit has built-in Dolby Pro Logic circuitry so you can enjoy Dolby Surround by connecting the speakers. 	<p>Software with the following mark is recorded in Dolby Pro Logic:</p> <ul style="list-style-type: none"> • Laser Disc • DVD • Video tape (VCR) • CD  <p>This mode cannot be used with the radio and 6CH DISCRETE INPUT mode.</p>			
<table border="1"> <tr> <td rowspan="2" style="vertical-align: middle;">SUPER SURROUND</td> <td style="text-align: center;">MOVIE mode</td> </tr> <tr> <td style="text-align: center;">MUSIC mode</td> </tr> </table> SIMULATED STEREO	SUPER SURROUND	MOVIE mode	MUSIC mode	<ul style="list-style-type: none"> • This mode adds surround effects to movie software that isn't recorded with the above systems. In MOVIE mode you can adjust the volume of the surround speaker to get the best surround effect. • This mode adds surround effects to normal music sources. • This mode adds stereo-like effects to monaural sound sources. 	<p>Any general sound source can be used.</p> <ul style="list-style-type: none"> • CD • Tape • Video tape <p>This mode cannot be used with the radio and 6CH DISCRETE INPUT mode.</p> <p>Any general sound source recorded in monaural can be used.</p> <ul style="list-style-type: none"> • CD • Tape • Video tape <p>This mode cannot be used with the radio and 6CH DISCRETE INPUT mode.</p>
SUPER SURROUND		MOVIE mode			
	MUSIC mode				

Add these audio effects to improve the experience

• Check the set-up of your speakers.

Set your speakers up to suit the surround mode you have selected to get the best surround effect. These modes cannot be used with the radio.

Virtual rear surround effect

- This mode is useful if you have to place your surround speakers on the front speakers because of the room's layout.
- This mode makes it seem like the sound from the surround speakers is coming from behind you.
- It is effective when using 6CH DISCRETE INPUT, DOLBY PRO LOGIC, or SUPER SURROUND MOVIE mode. (The [VIRTUAL REAR SURROUND] lamp turns orange.)

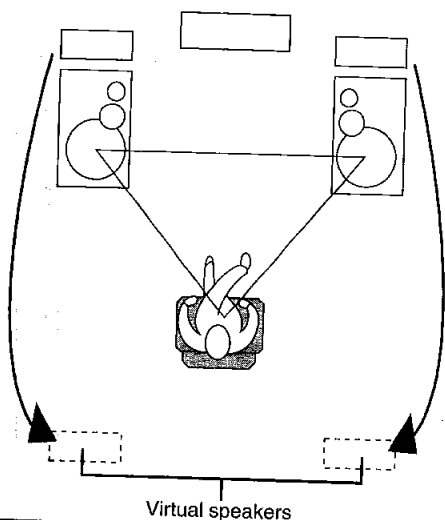

Center focus effect

- This mode makes it seem like the sound from the center speaker channel (dialogue, etc.) is coming from within the television.
- The center speaker must be placed on top of the television.
- It is effective when using 6CH DISCRETE INPUT or DOLBY PRO LOGIC. (The [CENTER FOCUS] lamp turns orange.)

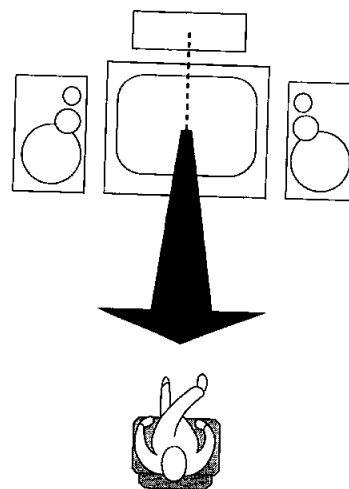

Multi rear surround effect

- Through processing of the surround sound signals, this mode makes it seem like there are multiple surround speakers in your room.
- This mode increases the cinema-like sense of presence.
- It is effective when using 6CH DISCRETE INPUT, DOLBY PRO LOGIC, or SUPER SURROUND MOVIE mode. (The [MULTI REAR SURROUND] lamp turns orange.)

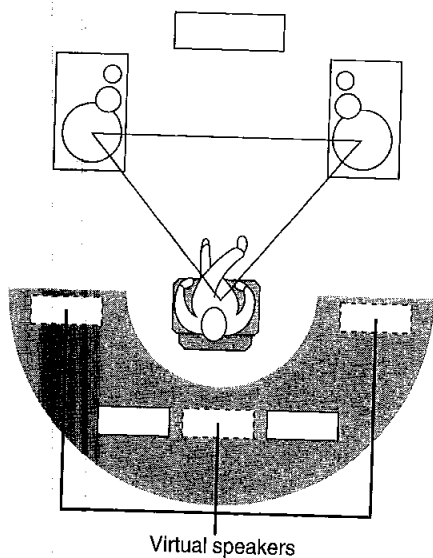

Seat position function

- This function helps maintain the sound signal position even if the listening position itself is changed.
- It is effective when using 6CH DISCRETE INPUT, DOLBY PRO LOGIC, or SUPER SURROUND MOVIE mode. (The [SEAT POSITION] lamp turns orange.)

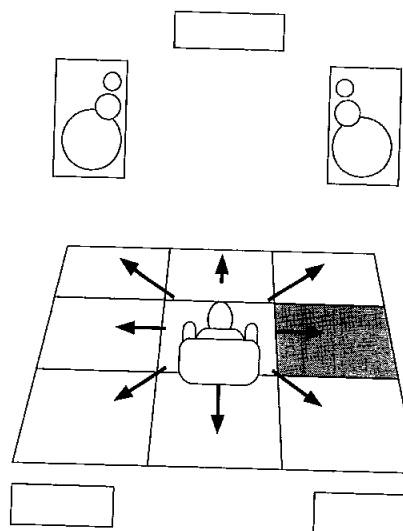

■ Enjoying Sound with 6 CH DISCRETE INPUT

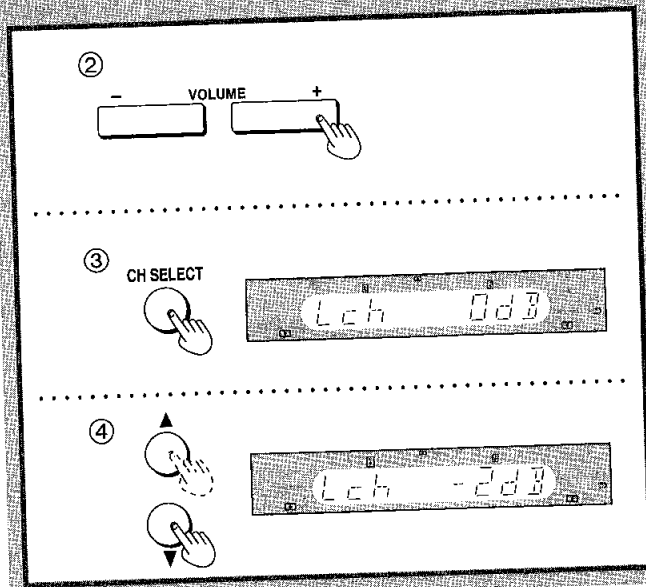
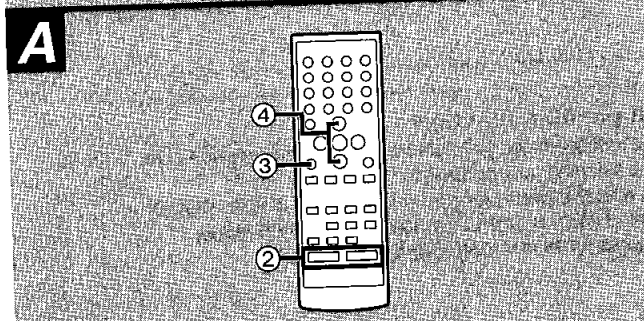
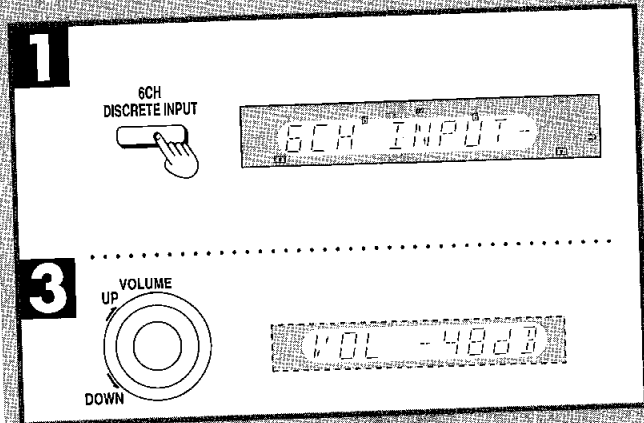
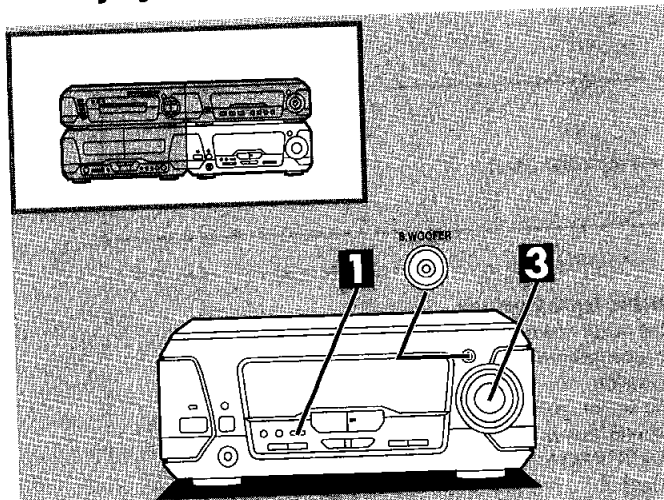

This mode allows you to enjoy the 5.1 channel Dolby Digital surround effects recorded on DVDs when they are played on a player which has 5.1 channel analog output.

1 Press [6CH DISCRETE INPUT].

For your reference

If you have connected a subwoofer (not included), press and hold [S. WOOFER] for about 2 seconds so "SUB W ON" is shown on the display. The SUBWOOFER can only be turned on and off if 6CH DISCRETE INPUT mode is selected.

2 Start playing the source (DVD).

Note

Do not switch input to AUX (DVD). This cancels 6CH DISCRETE INPUT mode.

3 Adjust the volume.

To adjust the volume of each speaker **A**

Sit in the normal listening position and make the adjustments with the remote control.

Preparation:

Press [6CH DISCRETE INPUT] to select 6CH DISCRETE INPUT mode.

① **Output the test signal from the DVD player (not included).**
Set the channel level to 0 dB on the DVD player, and adjust the channel level on this system.

② **Press [VOLUME (- or +)].**
Set the volume to the normal listening level.

The following steps are for setting the output level of the front speakers and the other speakers to approximately the same level.

③ **Press [CH SELECT].**
Select the speaker channel to be adjusted.

- L: Front speaker (Left)
- C: Center speaker
- R: Front speaker (Right)
- RS: Surround speaker (Right)
- LS: Surround speaker (Left)
- SW: Subwoofer

④ **Press [▲] or [▼].**
Adjust the output level.
▲: Increases the output level
▼: Decreases the output level
Repeat steps ③ and ④ to adjust the level accordingly.

Note

You cannot record sound or use MIC MIX when [6CH DISCRETE INPUT] is selected.

To record or use MIC MIX with DVDs, reconnect the DVD player from its MIXED OUT terminals to this unit's AUX (DVD) or VCR (EXT) IN terminals and select the external source with [INPUT SELECTOR].

Reference:

- Add audio effects to improve the surround effect.
- The 6CH DISCRETE INPUT mode is canceled when another source is selected.

■ To Playback a Dolby Surround Source with Dolby Pro Logic

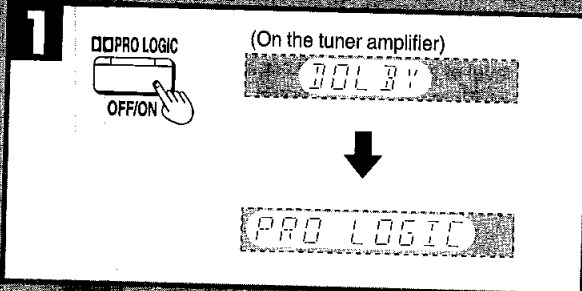
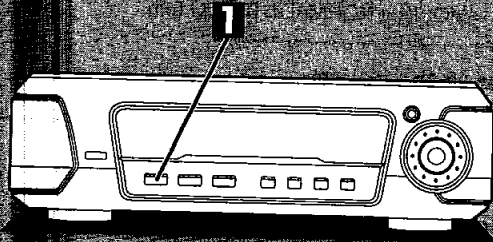
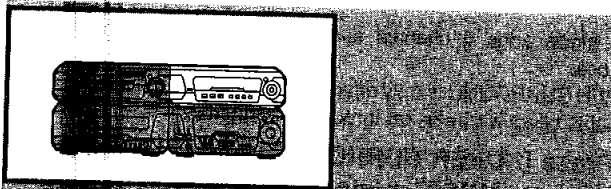

A

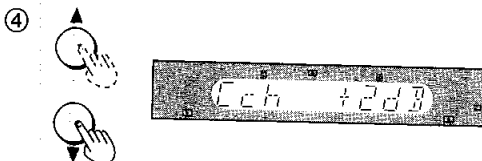
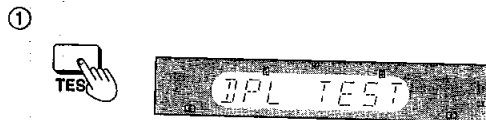
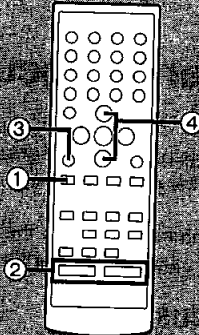

Use this mode when playing sources recorded with Dolby Pro Logic.

1 Press [**PRO LOGIC, OFF/ON**].
The [**PRO LOGIC**] lamp lights.

2 Playback a Dolby Surround source.

To turn off DOLBY PRO LOGIC

Press [**PRO LOGIC OFF/ON**].
The [**PRO LOGIC**] lamp goes out.

To adjust the volume of each speaker **A**

Sit in the normal listening position and make the adjustments with the remote control.

Preparation:

Press [**PRO LOGIC OFF/ON**] to turn on DOLBY PRO LOGIC.

1 Press [**TEST**].

A test signal is output.

The speaker outputting the test signal is displayed while the test is running.

L: Front speaker (Left)

C: Center speaker

R: Front speaker (Right)

S: Surround speakers

2 Press [**VOLUME (- or +)**].

Set the volume to the normal listening level.

The following steps are for setting the output level of the front speakers and the other speakers to the same listening level.

3 Press [**CH SELECT**].

Select the speaker channel to be adjusted.

C ch: Center channel

S ch: Surround channel

4 Press [**▲**] or [**▼**].

Adjust the output level. The level can be adjusted between +6 and -10.

▲: Increases the output level

▼: Decreases the output level

Repeat steps **3** and **4** to adjust the level accordingly.

To stop the test signal

Press [**TEST**] again.

Reference:

Add audio effects to improve the surround effect.

Manufactured under license from Dolby Laboratories Licensing Corporation.

DOLBY, the double-D symbol **DD** and "PRO LOGIC" are trademarks of Dolby Laboratories Licensing Corporation.

■ Enjoying Sound with Stereophonics (SUPER SURROUND) **A**

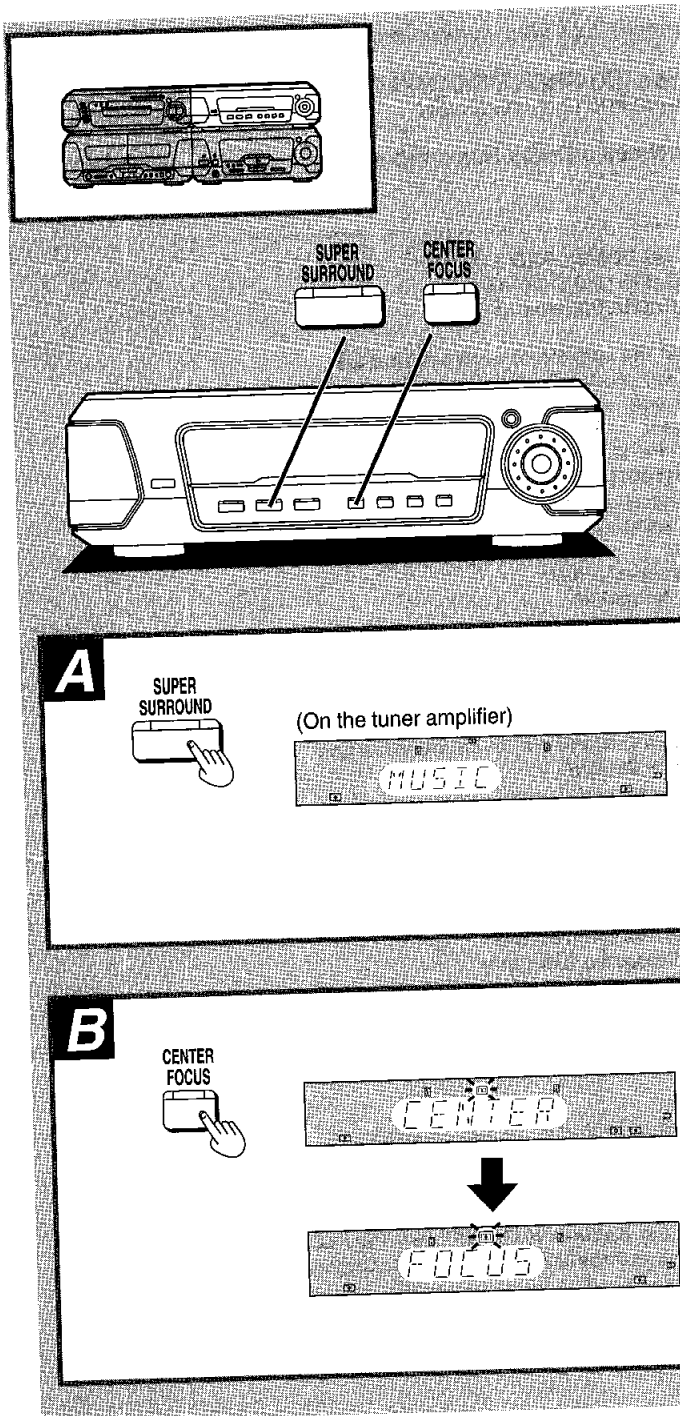

- This mode adds 5 channel surround effects to normal stereo sources.
- SUPER SURROUND is only effective if speakers are used. No discernable effect will be heard through headphones.

1 Press [SUPER SURROUND] and select **MOVIE mode or MUSIC mode.**

Each time the button is pressed;
MUSIC → MOVIE → NORMAL STEREO (off)

2 Playback the source.

To turn off the SUPER SURROUND mode
Press [SUPER SURROUND] to select "NORMAL STEREO".

To adjust the volume of surround speakers
You can change the output level of surround speakers manually. While enjoying the desired source:

1. Press [CH SELECT] on the remote control.
The output level of surround speakers is displayed.
2. Press [▲] or [▼] on the remote control.
Adjust the output level. The level can be adjusted between +6 and -10.
▲: Increase the output level
▼: Decrease the output level

Reference:

Add audio effects to improve the surround effect.

■ Using the Center Focus Effect **B**

- When the center speaker is put on the TV set, this mode makes it seem like the sound from the center speaker is coming from within the television.
- This mode can only be turned on or off if the [CENTER FOCUS] lamp is orange. The mode cannot be used if the lamp is off.

Press [CENTER FOCUS].

The [CENTER FOCUS] indicator turns green.

To turn off the CENTER FOCUS mode

Press [CENTER FOCUS].

With the remote control

1. Press [AV EFFECT].
2. Press [◀] or [▶] so the [CENTER FOCUS] lamp flashes.
3. Press [▼] (OFF) or [▲] (ON).

■ Using the Virtual Rear Surround Effect **A**

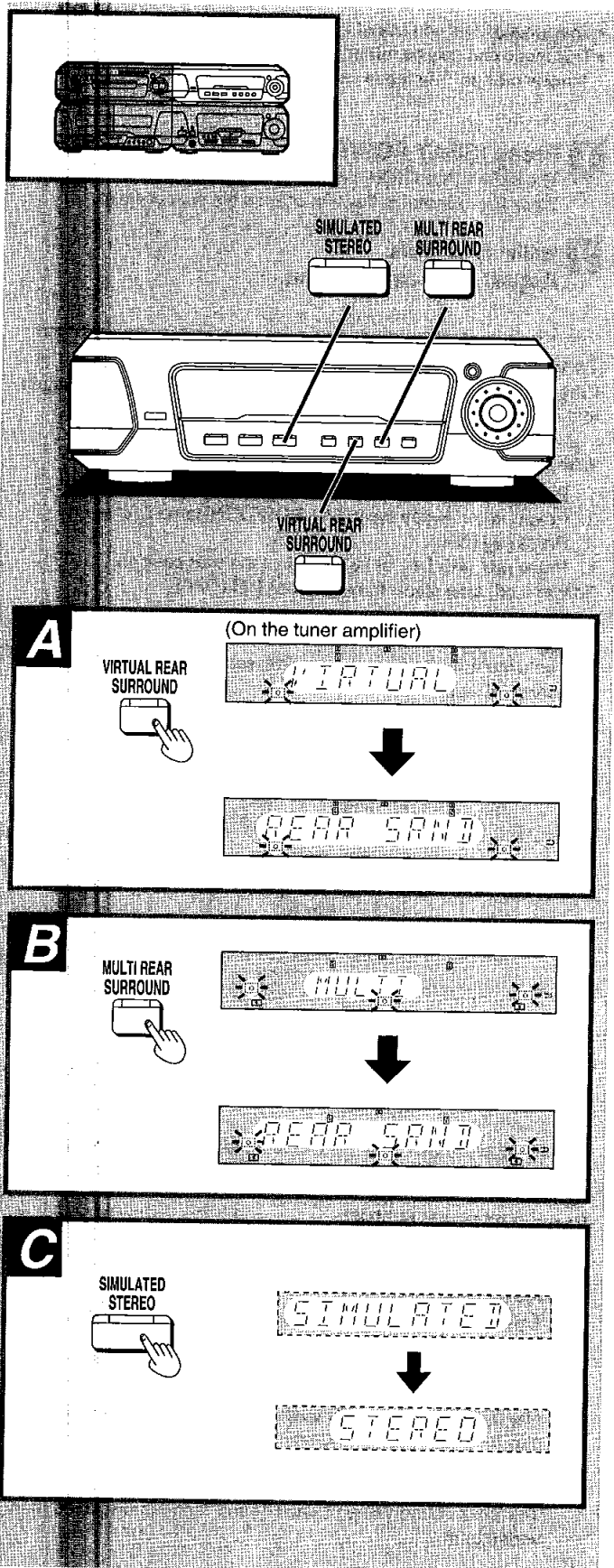

- When the surround speakers are put on the front speakers, this mode makes it seem like the sound from the surround speakers is coming from behind you.
- This mode can only be turned on or off if the "VIRTUAL REAR SURROUND" lamp is orange. The mode cannot be used if the lamp is off.

Press [VIRTUAL REAR SURROUND].

The [VIRTUAL REAR SURROUND] lamp turns green.

To turn off the VIRTUAL REAR SURROUND mode

Press [VIRTUAL REAR SURROUND].

With the remote control

1. Press [AV EFFECT].
2. Press [◀] or [▶] so the [VIRTUAL REAR SURROUND] lamp flashes.
3. Press [▼] (OFF) or [▲] (ON).

■ Using the Multi Rear Surround Effect **B**

- This mode makes it seem like there are multiple surround speakers in your room.
- This mode can only be turned on or off if the [MULTI REAR SURROUND] lamp is orange. The mode cannot be used if the lamp is off.

Press [MULTI REAR SURROUND].

The [MULTI REAR SURROUND] indicator turns green.

To turn off the MULTI REAR SURROUND mode

Press [MULTI REAR SURROUND].

With the remote control

1. Press [AV EFFECT].
2. Press [◀] or [▶] so the [MULTI REAR SURROUND] lamp flashes.
3. Press [▼] (OFF) or [▲] (ON).

■ Enjoy the Sound with Simulated Stereo **C**

This mode adds stereo effect to monaural sources.

1 Press [SIMULATED STEREO].

The [SIMULATED STEREO] lamp lights.

2 Playback the source.

To turn off the SIMULATED STEREO mode

Press [SIMULATED STEREO].

The [SIMULATED STEREO] lamp goes out.

■ Using the Seat Position Function **A**

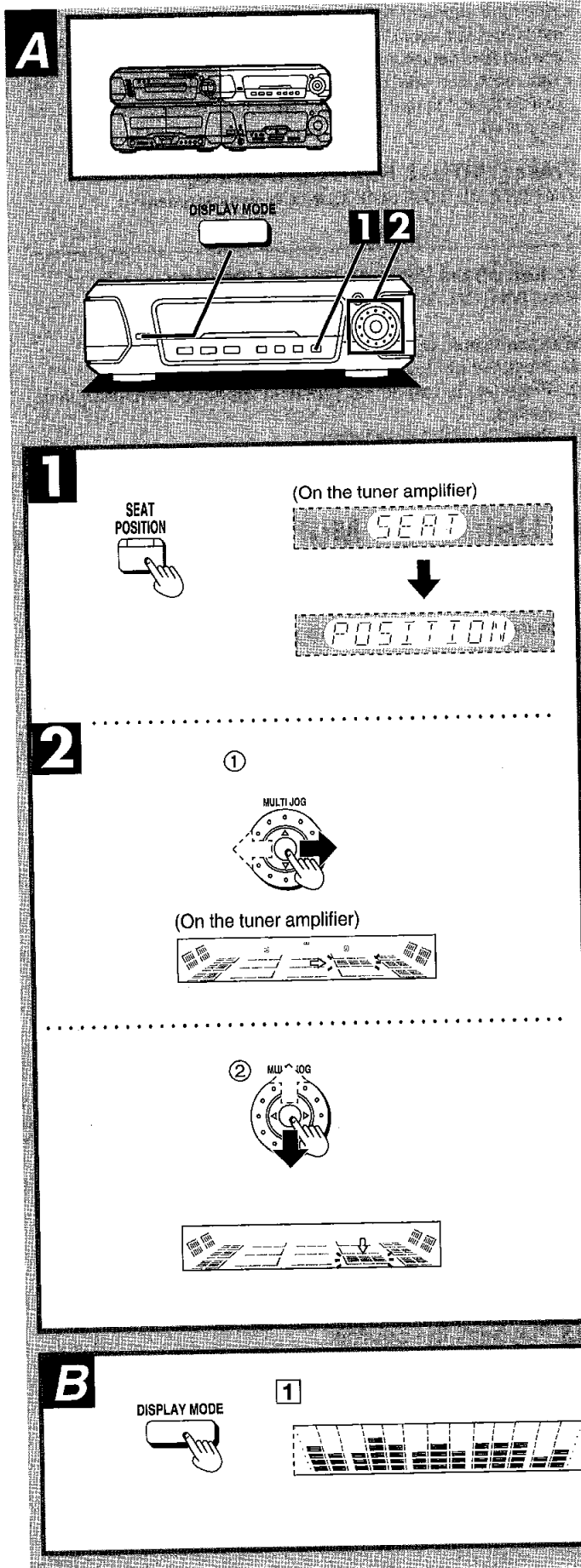

- This function lets you adjust the listening position for better effect.
- This mode can only be turned on or off if the [SEAT POSITION] lamp is orange. The mode cannot be used if the lamp is off.

1 Press [SEAT POSITION].

The [SEAT POSITION] lamp flashes green. While the indicator is flashing change the seat position.

2 Within 10 seconds Adjust the seat position.

To turn off the SEAT POSITION mode

Press [SEAT POSITION] once to select the function and once again to turn it off while the lamp flashes.

With the remote control

1. Press [AV EFFECT].
2. Press [◀] or [▶] so the [SEAT POSITION] lamp flashes.
3. Press [▲] (ON).
4. Press [◀], [▶], [▼], or [▲] to adjust the seat position. To turn it off, after steps 1 and 2, press [▼] (OFF).

Note

- When used with virtual rear surround, seat position is changed in 3 horizontal steps.

With virtual rear surround

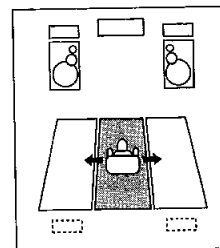

■ Concerning the Display **B**

The sound processor shows the level of each sound range with the three types of display described below. **B**

Press [DISPLAY MODE].

The spectrum display will change as follows.

- 1 Normal display**
This display indicates the strength of the sound in each tonal range.
- 2 Peak-hold display**
The peak sound value of each sound range is held on the display for about one second after it occurs.
- 3 Aurora display**
The peak sound value of each sound range is displayed in inverted form.

■ Using the External Unit

A

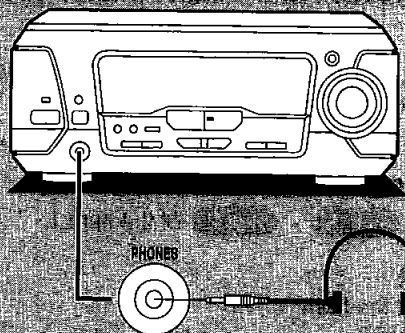

B

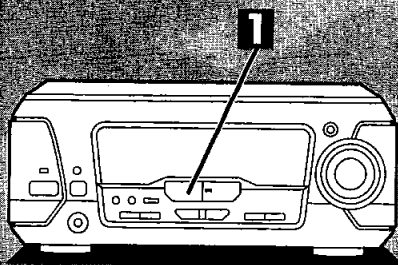

1



C

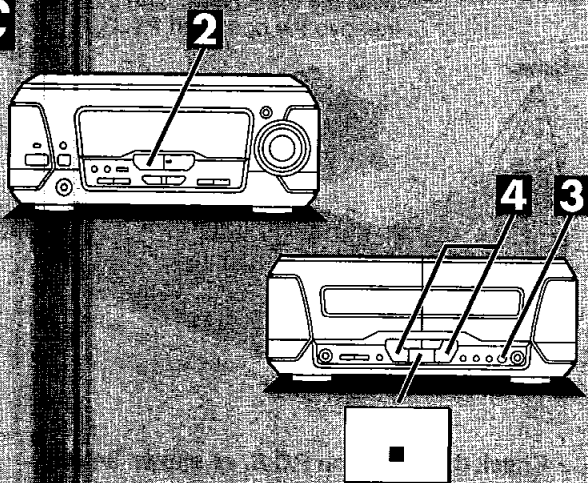

2

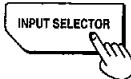

4

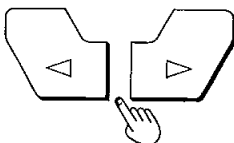

3



To use headphones

A

- Before connecting, reduce the volume level.
- Avoid listening for prolonged periods of time to prevent hearing damage.
- Plug type: 3.5 mm stereo

Listening to an external source

B

1 Press [INPUT SELECTOR] to select the external source.

Each time you press this button, sound sources will be switched as follows.

TUNER → CD → TAPE → VCR (EXT) → AUX (DVD)

2 Operate the external unit which you have connected to the system.

Refer to your equipment's operating instructions.

Recording from an external source

C

1 Press [▲ OPEN] on deck 2 and insert the tape.

2 Press [INPUT SELECTOR] to select the external source.

3 Press [● REC PAUSE] to put the cassette deck into the recording standby mode.

4 Press [◀] or [▶] to start recording.

5 Start playing the source to be recorded.

Refer to your equipment's operating instructions.

To stop recording:

Press [■] on the cassette deck.

To briefly interrupt recording:

Press [● REC PAUSE].

The cassette deck will go into the recording standby mode.

To resume recording:

Press [◀] or [▶] corresponding to the direction in which recording is taking place.

Recording on an external unit

First, select the source with [INPUT SELECTOR].

Start recording on an external unit, and then start playing the source to be recorded.

■ Operation Checks and Component Replacement Procedures

- NOTE**
1. This section describes procedures for checking the operation of the major printed circuit boards and replacing the main components.
 2. For reassembly after operation checks or replacement, reverse the respective procedures. Special reassembly procedures are described only when required.

1. Checking for the tuner P.C.B. and power supply P.C.B.

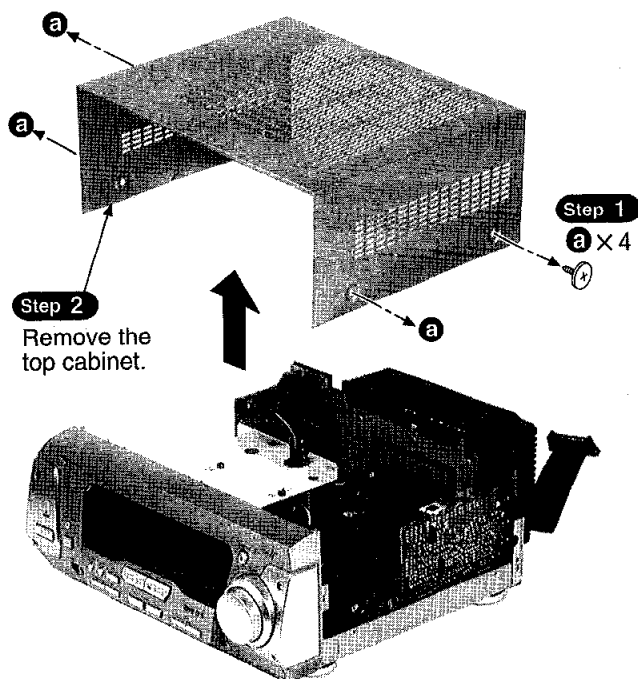

- Check the tuner P.C.B. and power supply P.C.B. as shown below.

Power supply P.C.B.

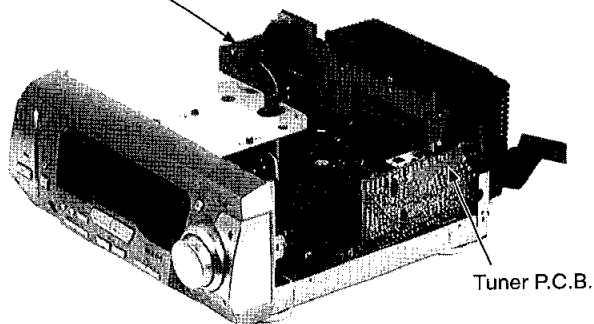

2. Checking for the operation P.C.B.

- Follow the Step 1 ~ Step 2 of the item 1.

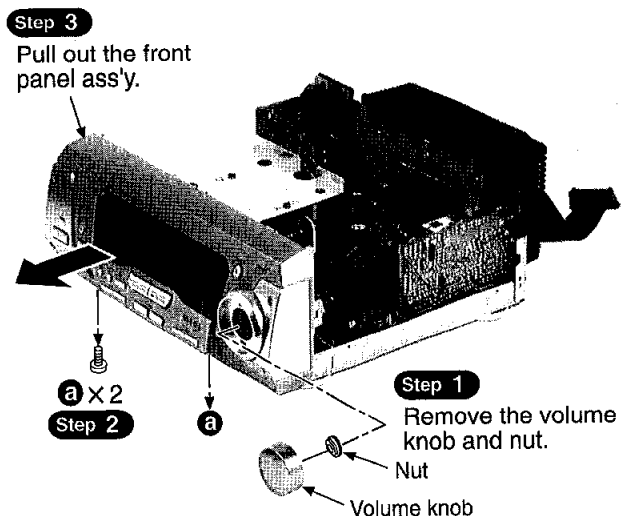

- Step 4
Release the 5 claws, and then remove the operation P.C.B..

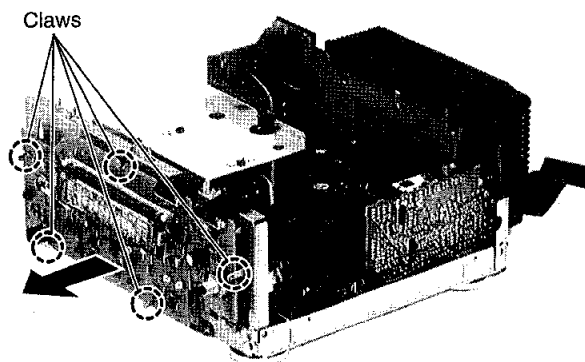

- Check the operation P.C.B. as shown below.

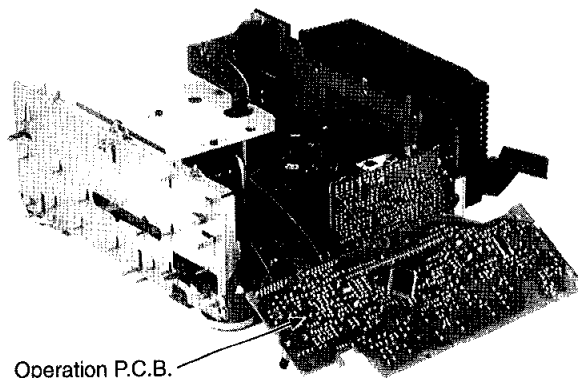

3. Checking for the main P.C.B.

- Follow the **Step 1** ~ **Step 2** of the item 1.
- Follow the **Step 1** ~ **Step 4** of the item 2.

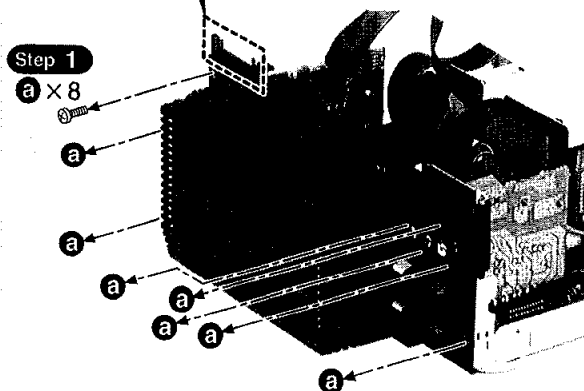
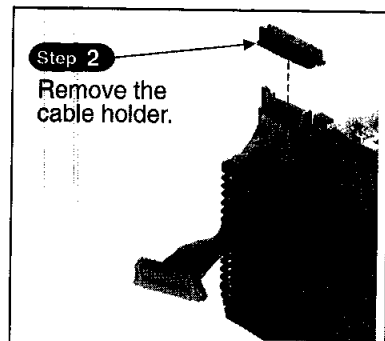

Step 3
Release the 2 claws, and then remove the rear grille ass'y.

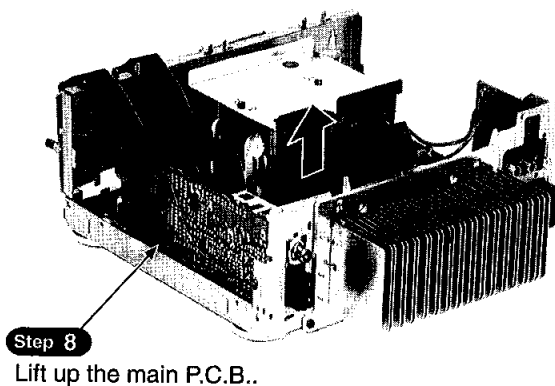
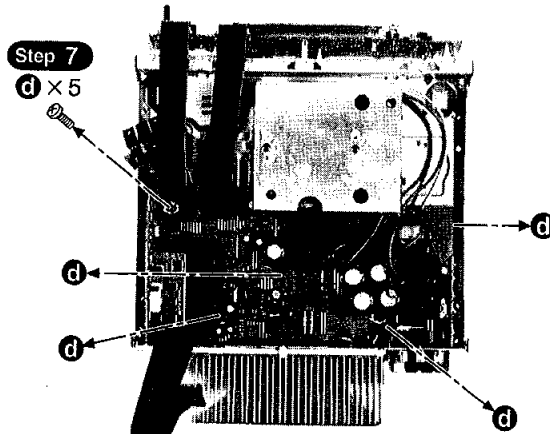
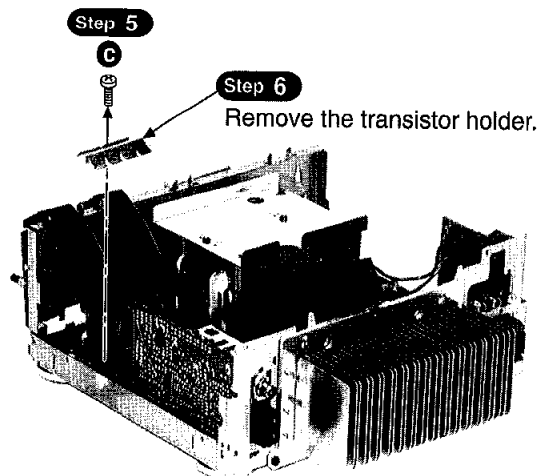
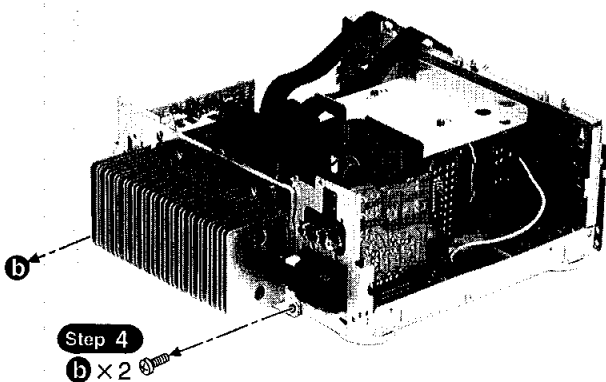
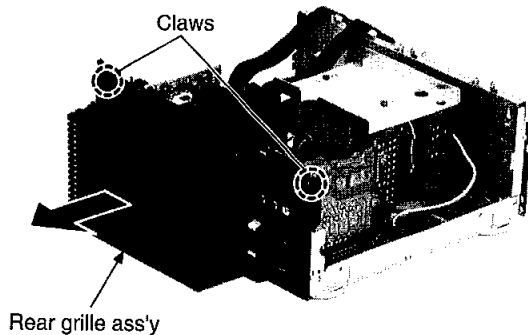

· Check the main P.C.B. as shown below.

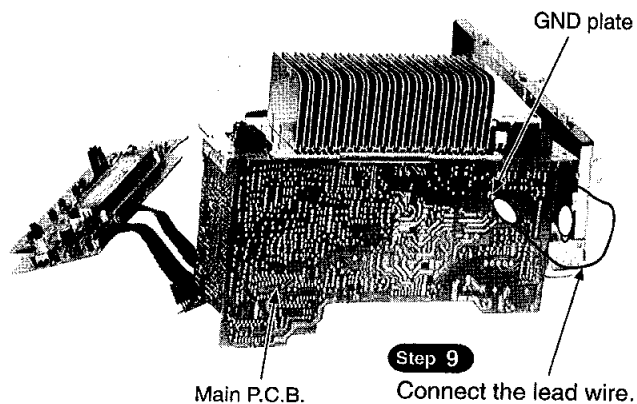

4. Replacement for the regulator transistor

Follow the **Step 1** ~ **Step 2** of the item 1.

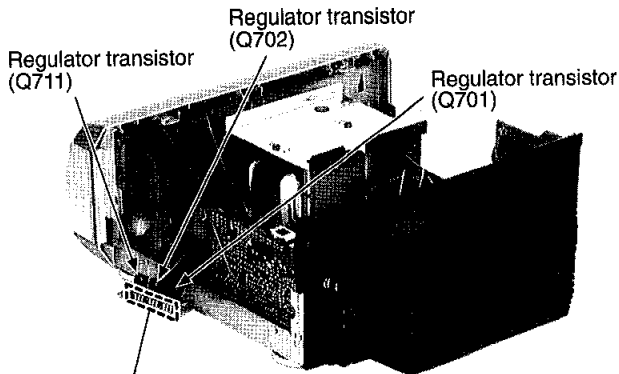
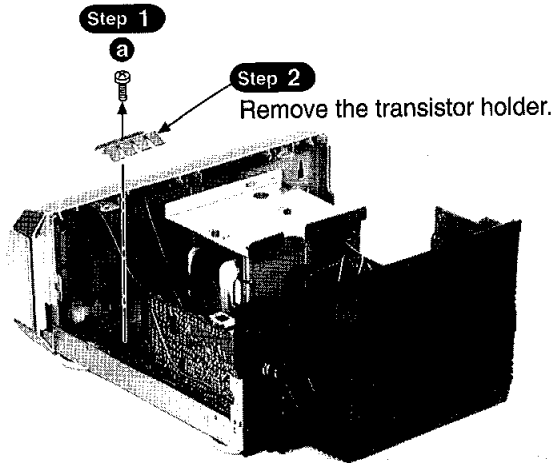

Step 3
Unsolder the terminals of regulator transistors.

5. Replacement for the power IC

- Follow the **Step 1** ~ **Step 2** of the item 1.
- Follow the **Step 1** ~ **Step 4** of the item 2.
- Follow the **Step 1** ~ **Step 8** of the item 3.

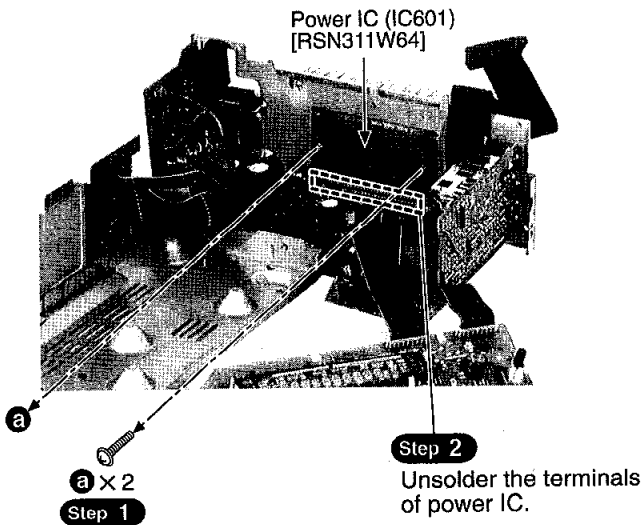

NOTE

When mounting the power IC apply silicone compound (RFKX0002) to the rear side of power IC.

Self-Diagnostic Mode

This unit is equipped with a self-diagnostic function which, in the event of a malfunction, automatically displays a code indicating the nature of the malfunction. Use this self-diagnostic function when servicing the unit.

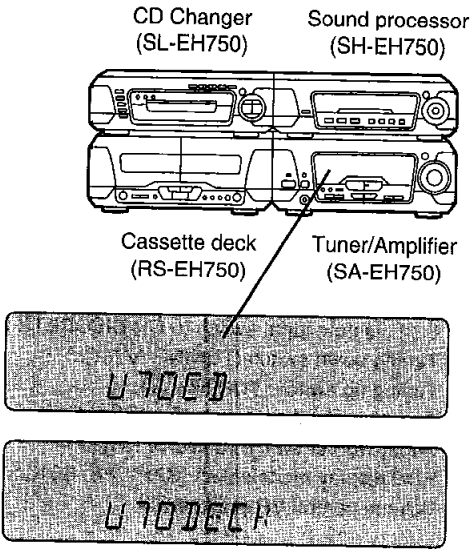
Display method	Display location
<p>To display the malfunction code</p> <p>U70 CD: U70 DECK: Automatically displays on the tuner/amplifier when a malfunction occurs.</p> <p>F61 Automatically displays on the tuner/amplifier when a malfunction occurs.</p> <p>To return to the normal display</p> <p>1. For U70 CD/U70 DECK:</p> <ul style="list-style-type: none"> Press any operation button on the tuner/amplifier. To re-display the code, switch the power off (POWER STANDBY button), and then switch power back on again. <p>2. For F61:</p> <ul style="list-style-type: none"> If "F61" is displayed, the power will automatically be switched off and the standby indicator will light up. "F61" will be displayed for 3 seconds, and then the clock will be displayed. To re-display the code, switch the power on. "F61" will be re-displayed, and then after 3 seconds the clock will be displayed and the power will automatically switch off. 	 <p>CD Changer (SL-EH750) Sound processor (SH-EH750)</p> <p>Cassette deck (RS-EH750) Tuner/Amplifier (SA-EH750)</p> <p>U70CD</p> <p>U70DECK</p>

Display contents

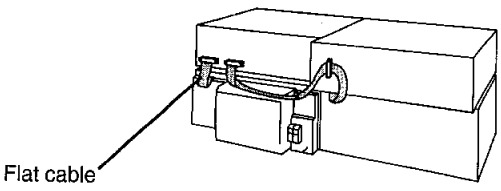
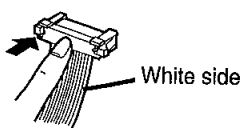
Display code	Problem or condition	Correction procedure
<p>U70 CD U70 DECK (displayed automatically)</p>	<p>A bus-line communications error has occurred as a result of the flat cables being inserted incorrectly, thus preventing the system from operating.</p> <p>1. If "U70" is displayed on the tuner/amplifier, the tape deck or CD Changer cannot be operated by remote control.</p>	 <p>Flat cable</p> <p>1. To check for correct insertion of the flat cables.</p> <ol style="list-style-type: none"> Insert each connector until you hear a click. Insert the flat cables at the back of the unit in the order indicated. Make sure the white side of the cable is on your right side.  <p>White side</p> <p>2. Breakage of flat cable. (Check and replace as necessary.)</p> <p>3. If the problem is not corrected by items (1.) and (2.) above, this indicates a faulty IC.</p> <p>SA-EH750: IC901 (LC8A524A5K01)</p> <p>SL-EH750: IC451 (M38504M6200F)</p> <p>RS-EH750: IC701 (M38503M2400F)</p> <p>Check these IC's and replace as necessary.</p>
<p>F61</p>	<p>When the power switch is switched on, it automatically switches back off, making it impossible to switch power on.</p>	<ul style="list-style-type: none"> Faulty Tuner/Amplifier (SA-EH750) output IC (IC601). (When a DC voltage is applied to the speaker terminals.)

■ Schematic Diagram

	Page		Page
A TUNER CIRCUIT	31, 32	E SPEAKER TERMINAL CIRCUIT	39
B OPERATION CIRCUIT	33 – 35	F POWER TRANSFORMER (A) CIRCUIT	39
C MAIN CIRCUIT	36 – 39	G POWER TRANSFORMER (B) CIRCUIT	39
D POWER SUPPLY CIRCUIT	38		

- This schematic diagram may be modified at any time with the development of new technology.

Notes:

- **S901** : Power "Standby/on" switch (⏻ / I)
- **S902** : ECO mode switch (ECO)
- **S903** : Clock timer,demo switch (CLOCK/TIMER, ■ DEMO)
- **S904** : Play timer/Record timer switch (⊕PLAY/⊕REC)
- **S905** : FM mode select switch (FM AUTO/MONO)
- **S906** : Tuning mode select switch (TUNING MODE)
- **S907** : Set switch (SET)
- **S908** : Source input select switch (INPUT SELECTOR)
- **S909** : 6 ch discrete input switch (6 CH DISCRETE INPUT)
- **S910** : Tuning down switch (TUNING ∨)
- **S911** : Tuning up switch (TUNING ∧)
- **S912** : Tuner/band select switch (TUNER/BAND)
- **S913** : Super woofer switch (S.WOOFER)
- **S914,915** : RDS display mode select (S914: PS, S915 : PTY) switch (RDS DISP MODE)
- **VR901** : Volume control VR (VOLUME)

- Indicated voltage values are the standard values for the unit measured by the DC electronic circuit tester (high-impedance) with the chassis taken as standard. Therefore, there may exist some errors in the voltage values, depending on the internal impedance of the DC circuit tester.

No mark: FM () : AM

- Important safety notice:

Components identified by Δ mark have special characteristics important for safety.

Furthermore, special parts which have purposes of fire-retardant (resistors), high-quality sound (capacitors), low-noise (resistors), etc. are used. When replacing any of components, be sure to use only manufacturer's specified parts shown in the parts list.

- **Caution!**

IC and LSI are sensitive to static electricity.

Secondary trouble can be prevented by taking care during repair.









Cover the parts boxes made of plastics with aluminum foil.

Ground the soldering iron.

Put a conductive mat on the work table.

Do not touch the legs of IC or LSI with the fingers directly.

- **Voltage and signal line**

	: Positive voltage line		: Negative voltage line
	: AM signal line		: AM OSC signal line
	: FM signal line		: FM OSC signal line
	: Center Sp.drive signal line		: Surround Sp.drive signal line
	: Source signal line		

SCHEMATIC DIAGRAM-1

Note: The number which noted at the connectors on the schematic diagram as "SCHEMATIC DIAGRAM-1" or "SCHEMATIC DIAGRAM-2" indicates the schematic diagram serial number located on the left corner in the schematic diagram.

: FM SIGNAL LINE : AM SIGNAL LINE
 : POSITIVE VOLTAGE LINE : FM OSC SIGNAL LINE : AM OSC SIGNAL LINE

A TUNER CIRCUIT

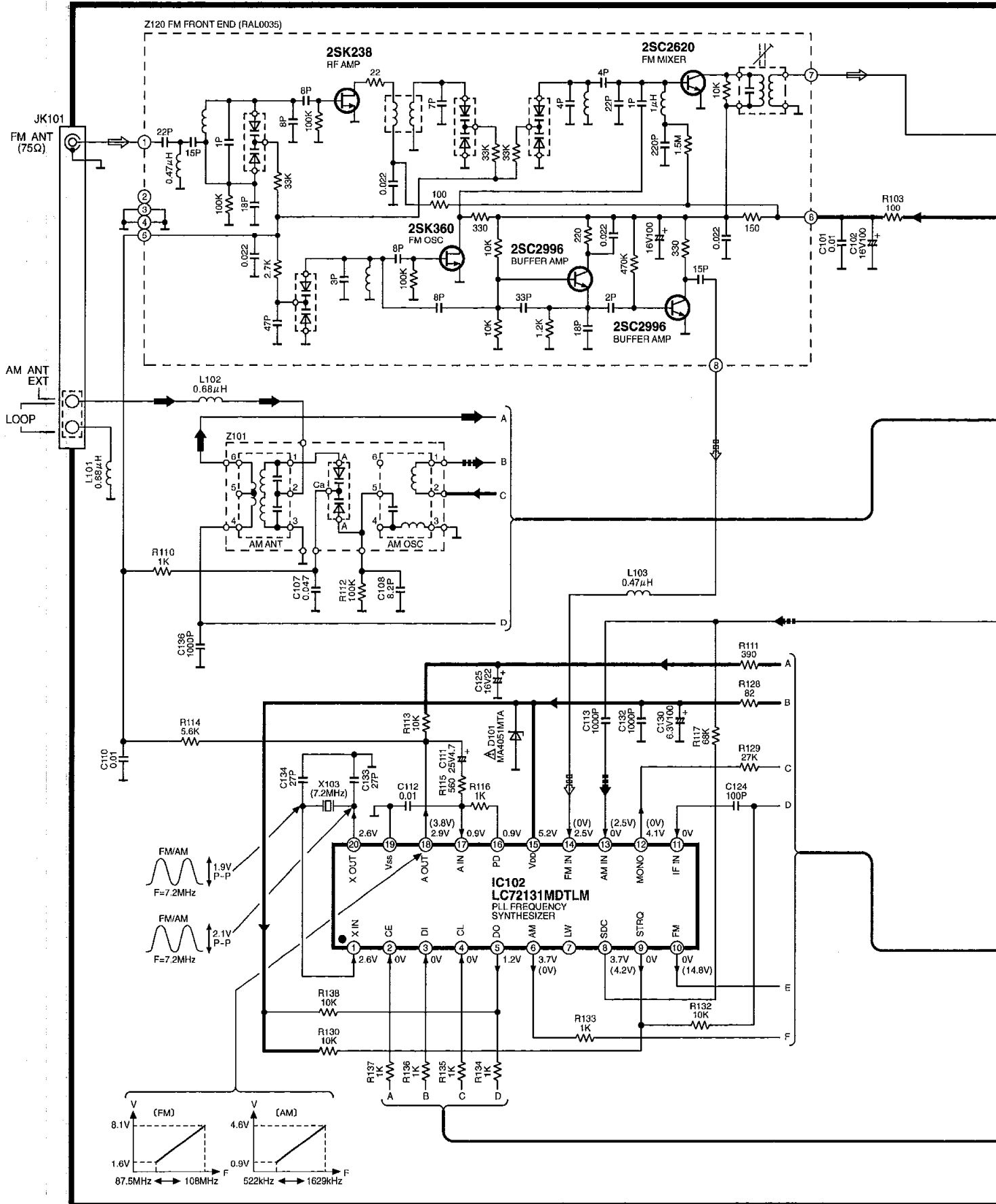

SCHEMATIC DIAGRAM-2

→ : POSITIVE VOLTAGE LINE ⇨ : FM SIGNAL LINE ➡ : AM SIGNAL LINE ⇨⇨ : AM OSC SIGNAL LINE

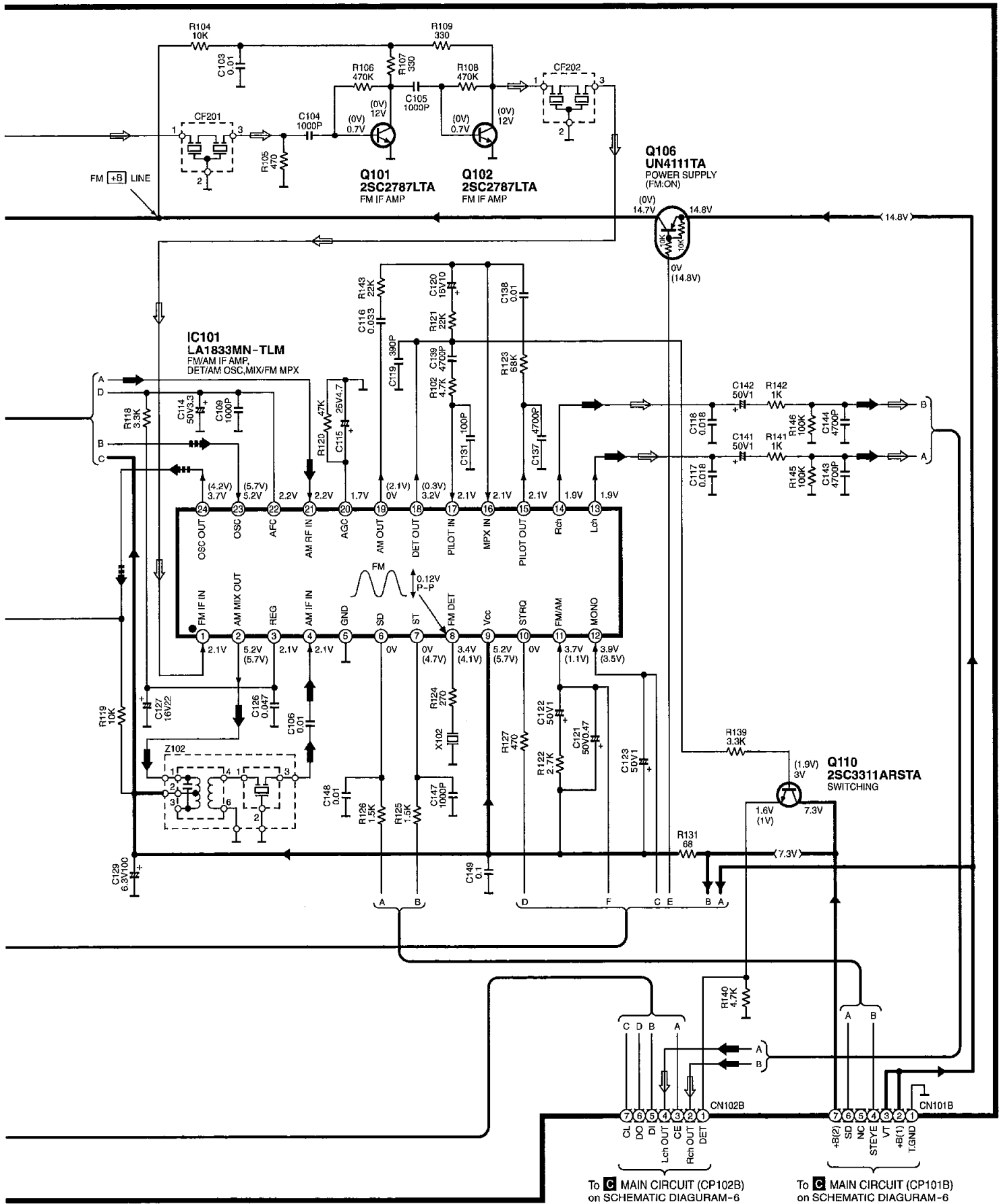

SCHEMATIC DIAGRAM-3

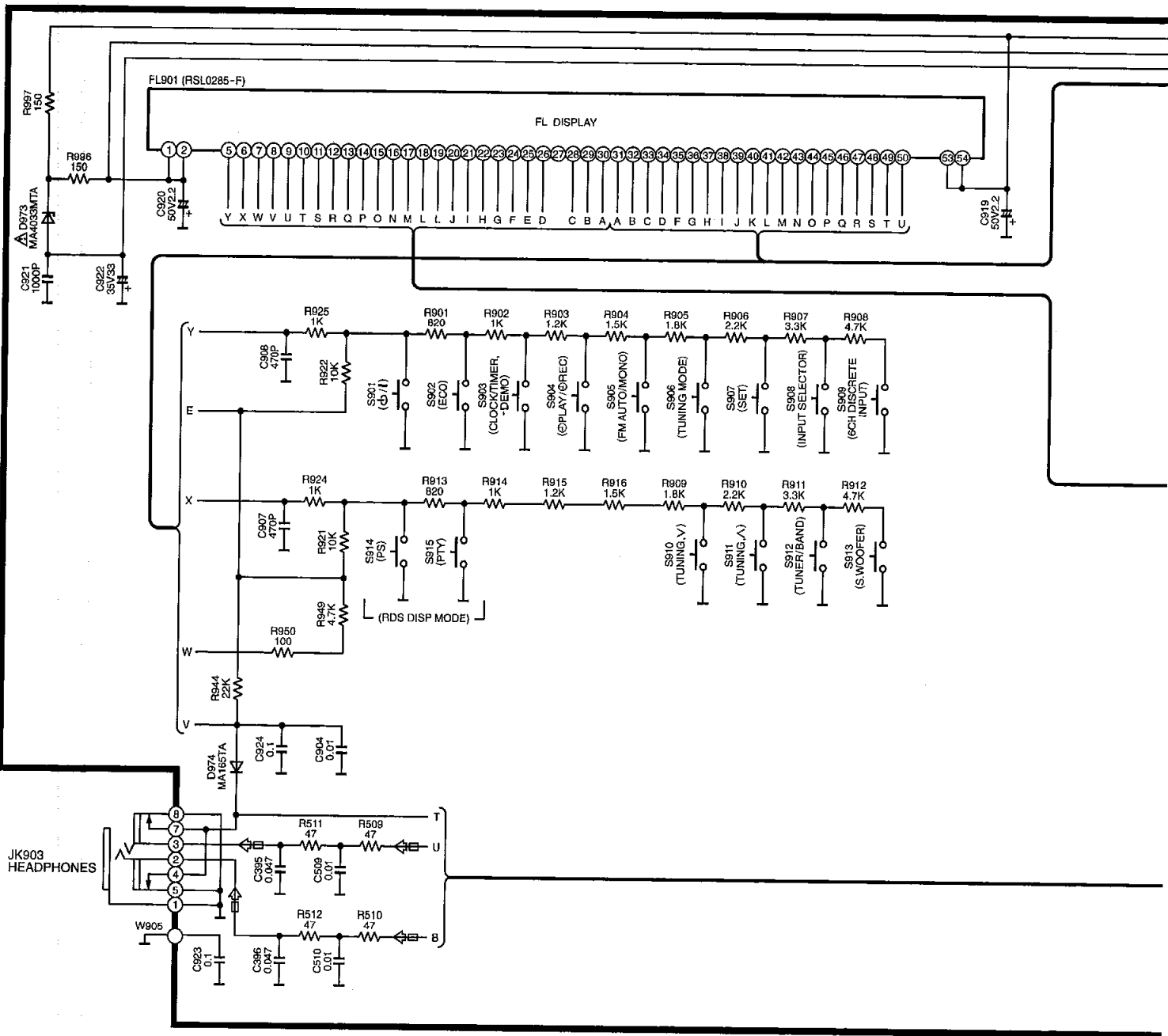

B OPERATION CIRCUIT

□▷ : SOURCE SIGNAL LINE



SCHEMATIC DIAGRAM-5

B OPERATION CIRCUIT

 : POSITIVE VOLTAGE LINE
 : NEGATIVE VOLTAGE LINE  : SOURCE SIGNAL LINE

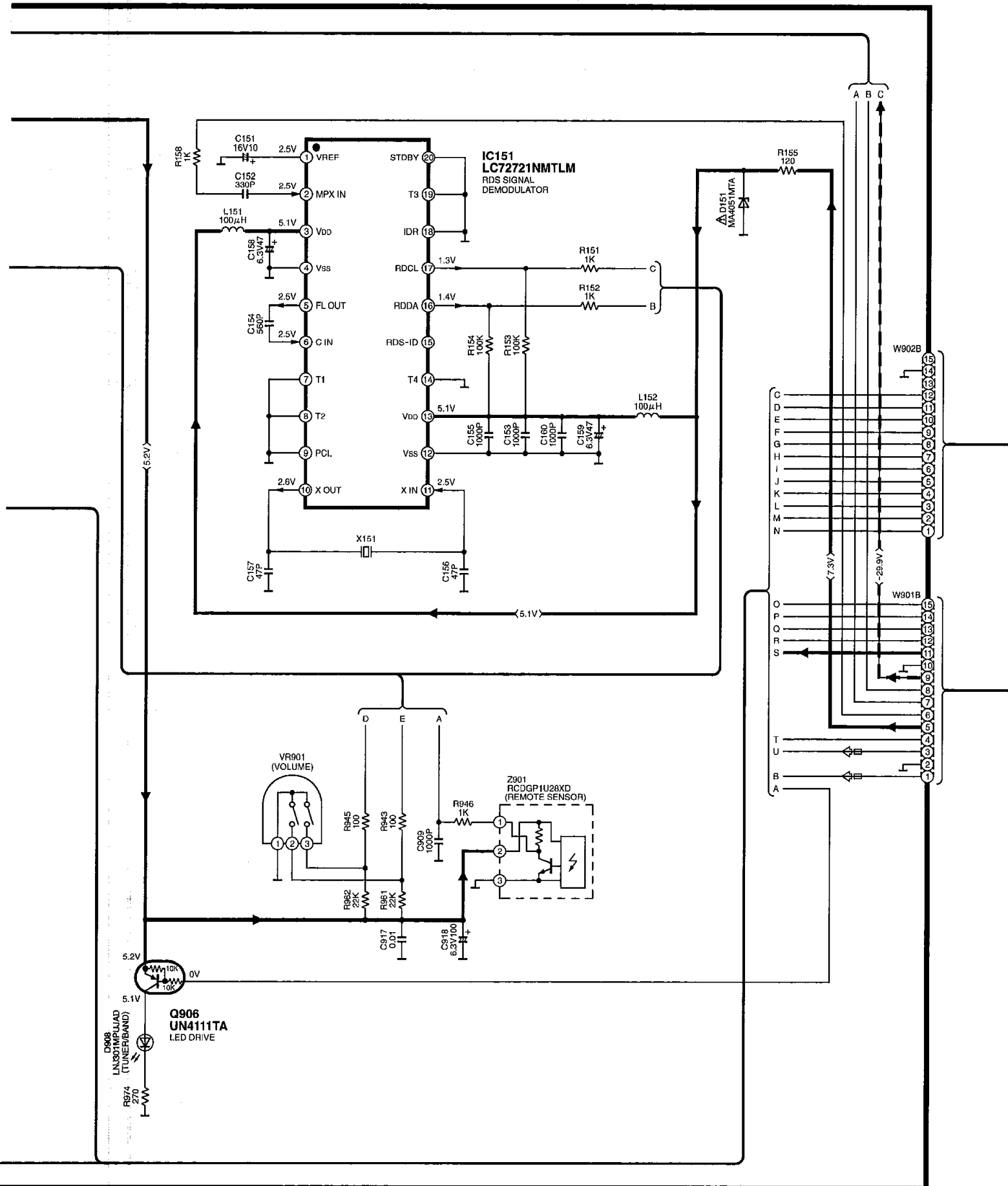

SCHEMATIC DIAGRAM-6

C MAIN CIRCUIT

: POSITIVE VOLTAGE LINE
 : NEGATIVE VOLTAGE LINE
 : FM SIGNAL LINE
 : AM SIGNAL LINE
 : SURROUND SP.DRIVE SIGNAL LINE
 : CENTER SP.DRIVE SIGNAL LINE
 : SOURCE SIGNAL LINE

To SOUND PROCESSOR MAIN CIRCUIT

To **A** TUNER CIRCUIT (CN101B) on SCHEMATIC DIAGRAM-2

To **A** TUNER CIRCUIT (CN102B) on SCHEMATIC DIAGRAM-2

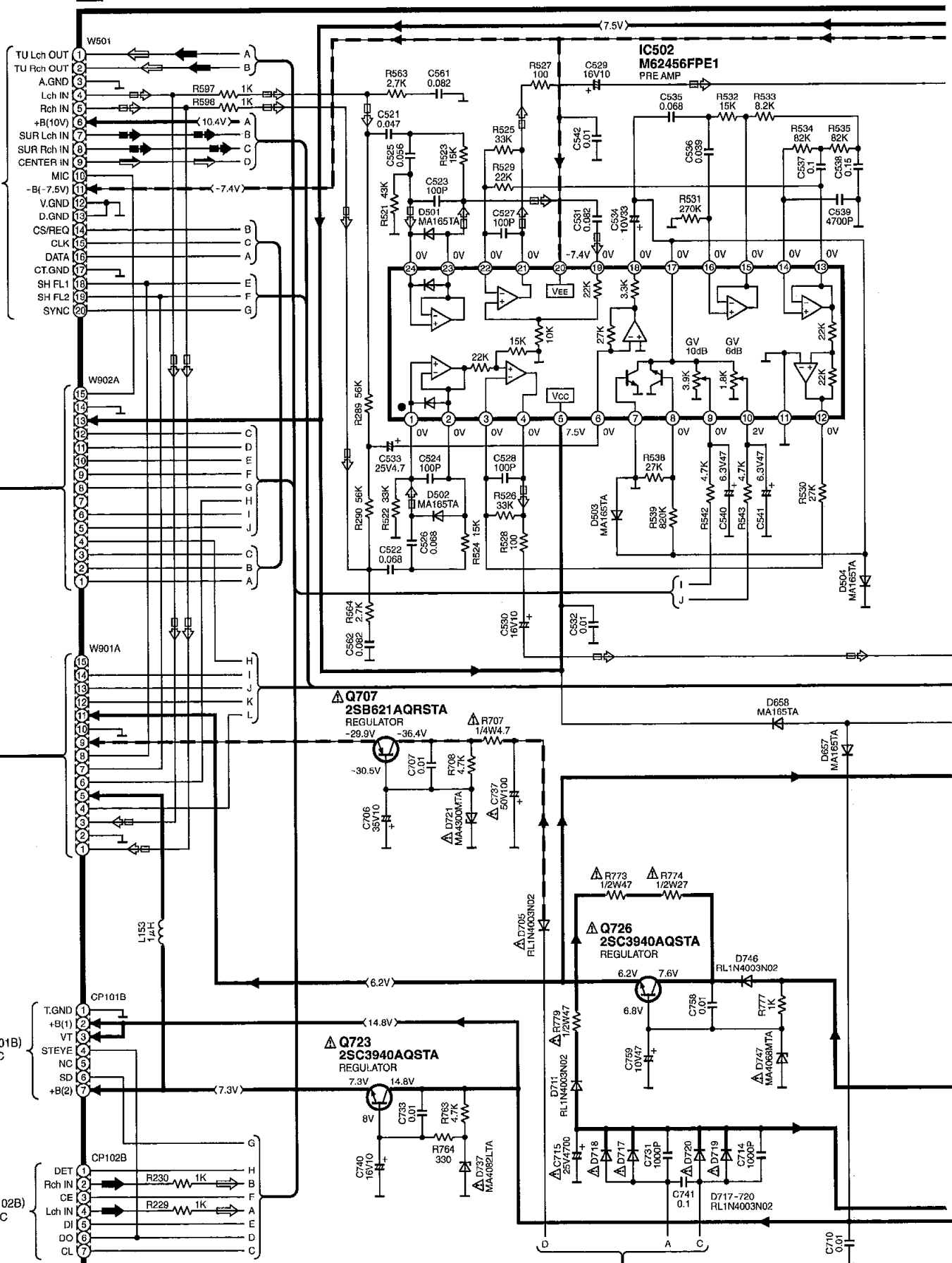

SCHEMATIC DIAGRAM-7

—▶ : POSITIVE VOLTAGE LINE ▶ : SURROUND SP.DRIVE SIGNAL LINE
 - -▶ : NEGATIVE VOLTAGE LINE ◀ : CENTER SP.DRIVE SIGNAL LINE ◻◁ : SOURCE SIGNAL LINE

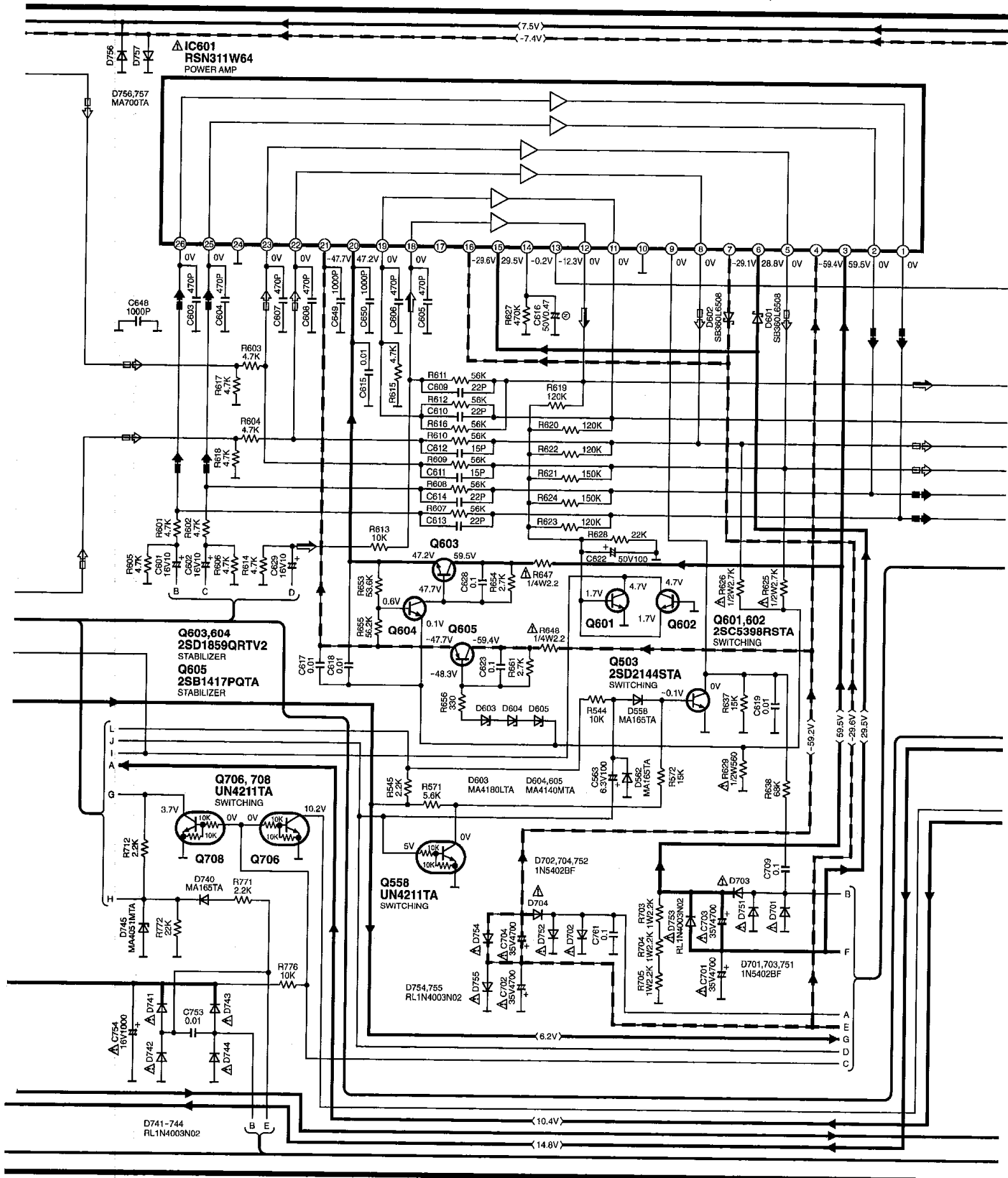

SCHEMATIC DIAGRAM-8

C MAIN CIRCUIT

: POSITIVE VOLTAGE LINE
 : SURROUND SP.DRIVE SIGNAL LINE
 : NEGATIVE VOLTAGE LINE
 : CENTER SP.DRIVE SIGNAL LINE
 : SOURCE SIGNAL LINE

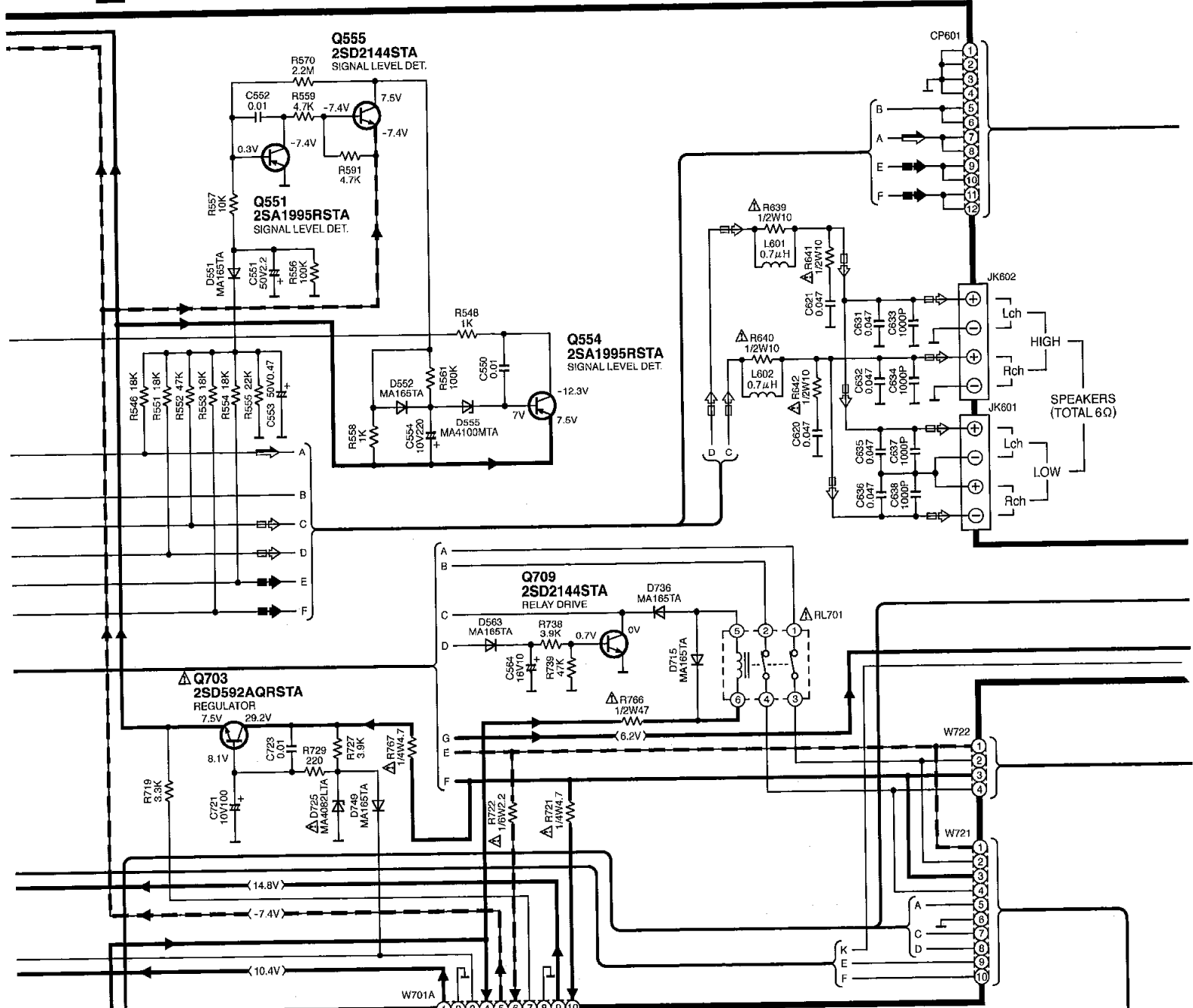

D POWER SUPPLY CIRCUIT

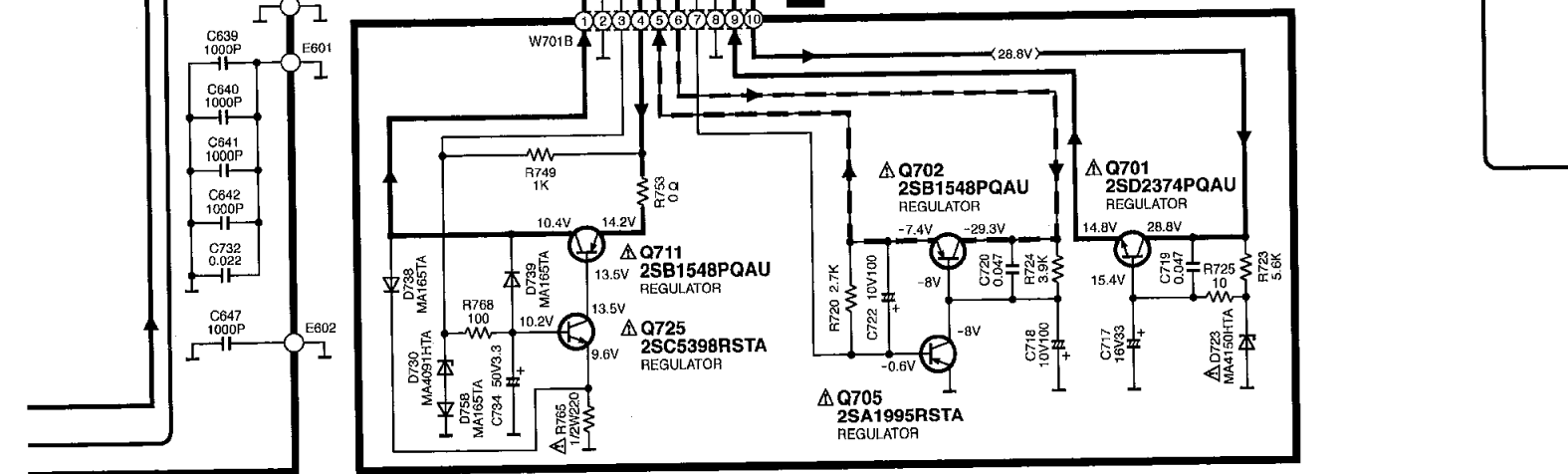

SCHEMATIC DIAGRAM-9

E SPEAKER TERMINAL CIRCUIT

- ▶— : POSITIVE VOLTAGE LINE
- -▶- : NEGATIVE VOLTAGE LINE
- ▶ : SURROUND SP.DRIVE SIGNAL LINE
- ◻▶ : CENTER SP.DRIVE SIGNAL LINE

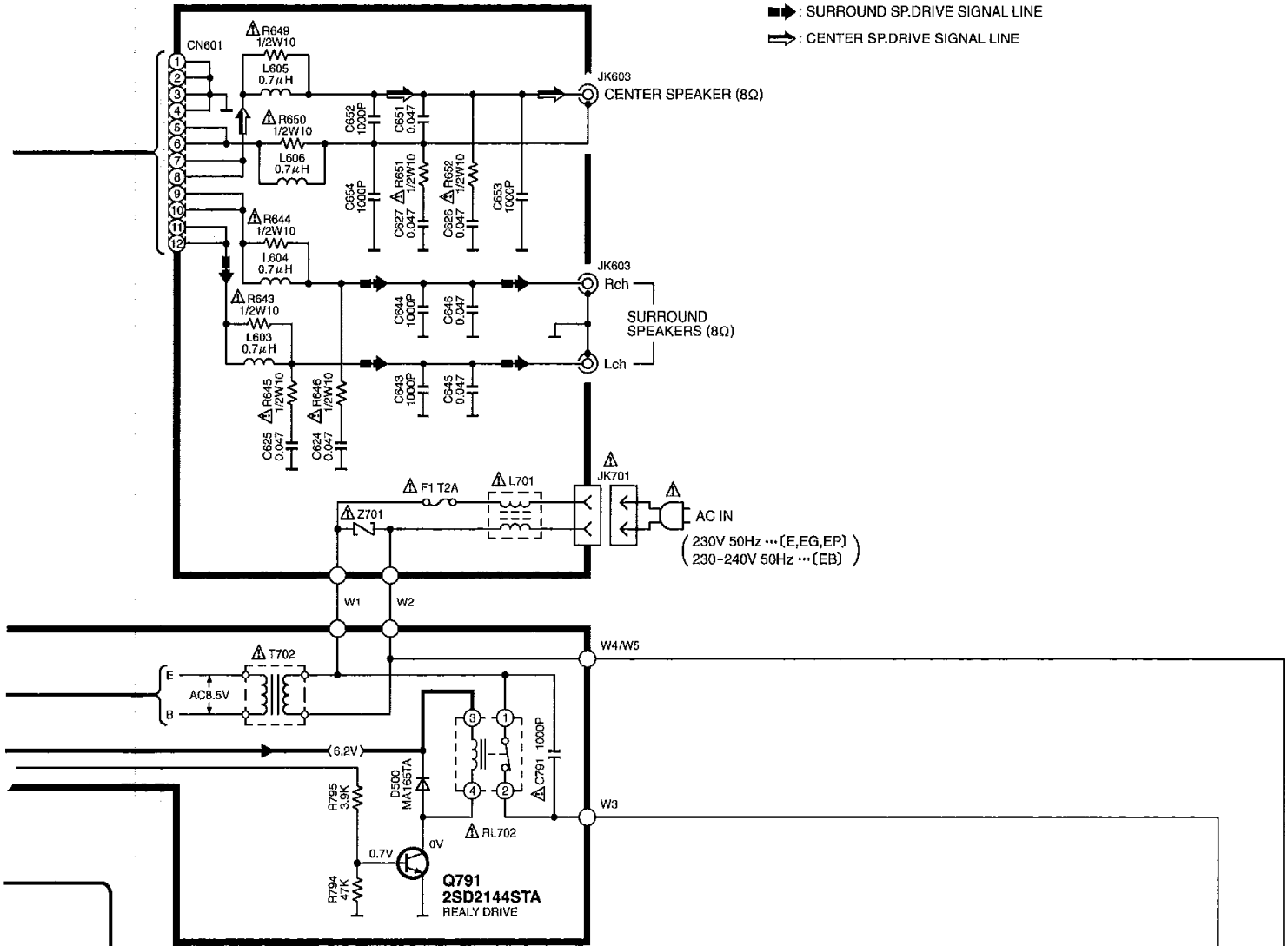

F POWER TRANSFORMER (A) CIRCUIT

G POWER TRANSFORMER (B) CIRCUIT

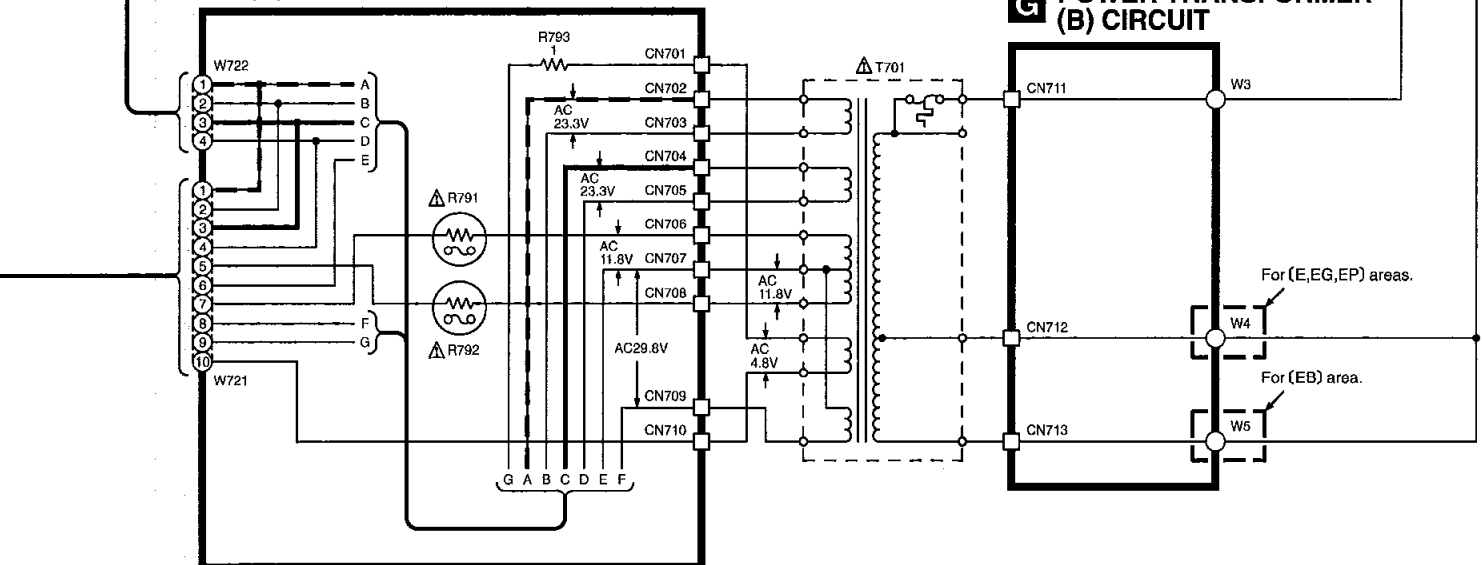

Printed Circuit Board Diagram

• This circuit board diagram may be modified at any time with the development of new technology.

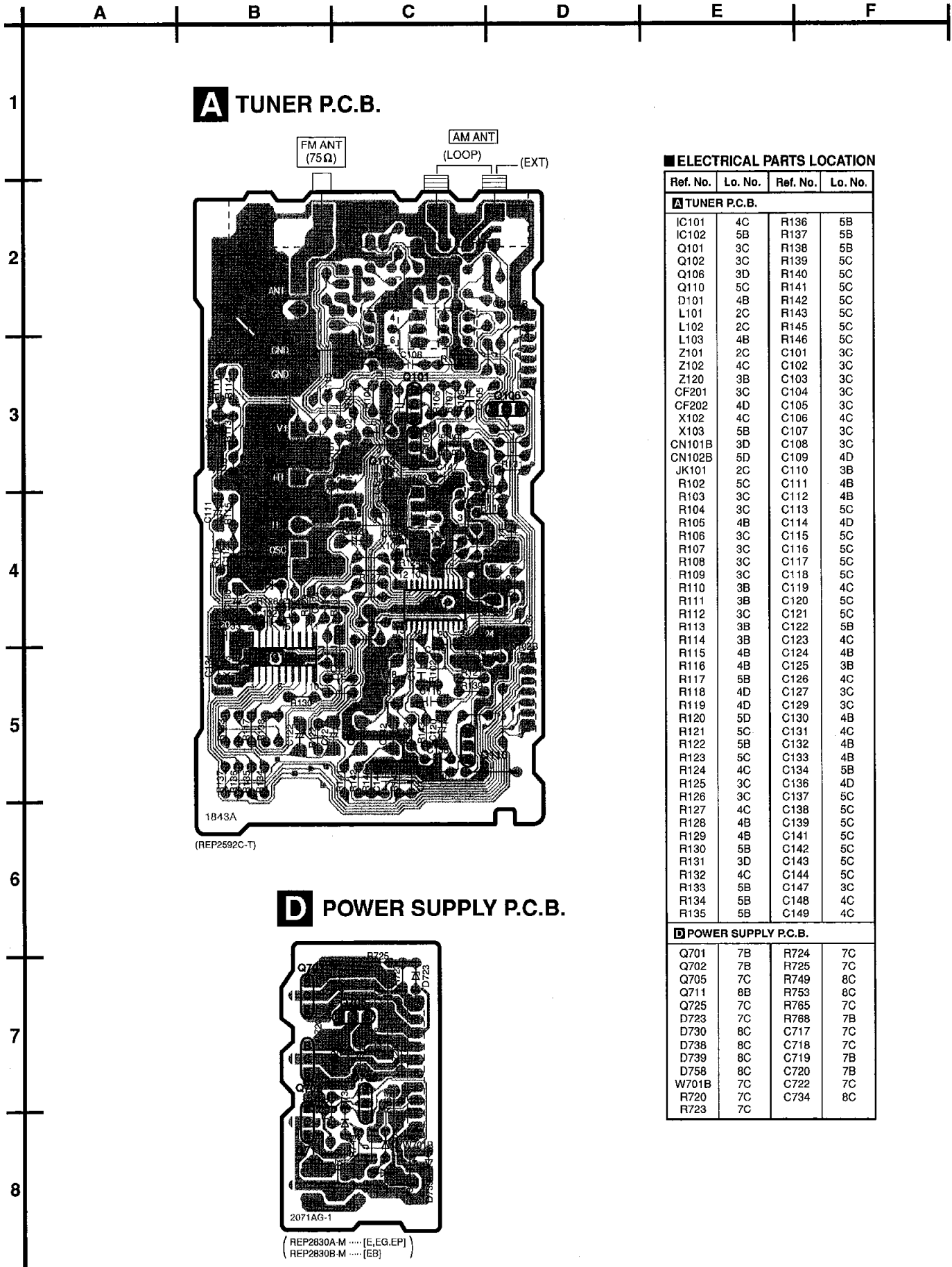

A TUNER P.C.B.

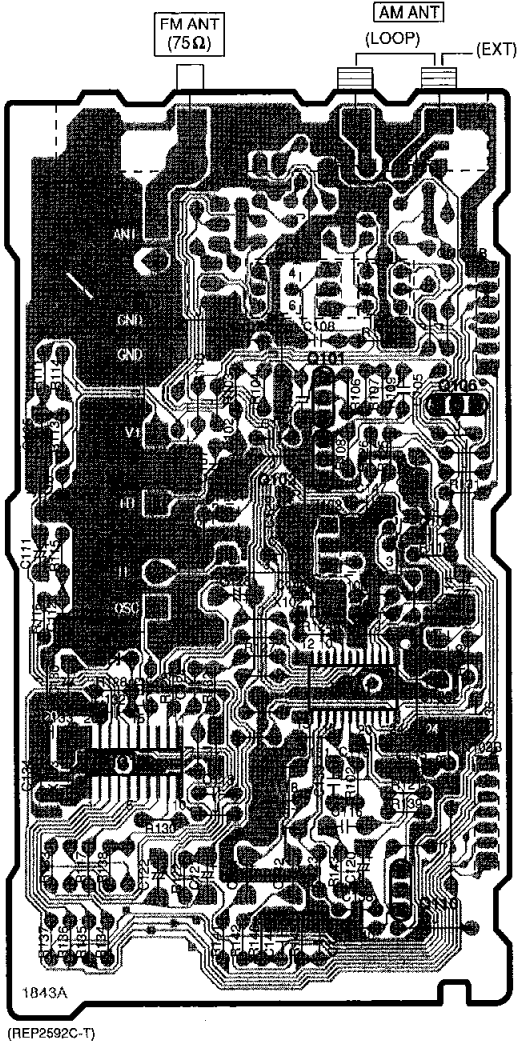

ELECTRICAL PARTS LOCATION

Ref. No.	Lo. No.	Ref. No.	Lo. No.
A TUNER P.C.B.			
IC101	4C	R136	5B
IC102	5B	R137	5B
Q101	3C	R138	5B
Q102	3C	R139	5C
Q106	3D	R140	5C
Q110	5C	R141	5C
D101	4B	R142	5C
L101	2C	R143	5C
L102	2C	R145	5C
L103	4B	R146	5C
Z101	2C	C101	3C
Z102	4C	C102	3C
Z120	3B	C103	3C
CF201	3C	C104	3C
CF202	4D	C105	3C
X102	4C	C106	4C
X103	5B	C107	3C
CN101B	3D	C108	3C
CN102B	5D	C109	4D
JK101	2C	C110	3B
R102	5C	C111	4B
R103	3C	C112	4B
R104	3C	C113	5C
R105	4B	C114	4D
R106	3C	C115	5C
R107	3C	C116	5C
R108	3C	C117	5C
R109	3C	C118	5C
R110	3B	C119	4C
R111	3B	C120	5C
R112	3C	C121	5C
R113	3B	C122	5B
R114	3B	C123	4C
R115	4B	C124	4B
R116	4B	C125	3B
R117	5B	C126	4C
R118	4D	C127	3C
R119	4D	C129	3C
R120	5D	C130	4B
R121	5C	C131	4C
R122	5B	C132	4B
R123	5C	C133	4B
R124	4C	C134	5B
R125	3C	C136	4D
R126	3C	C137	5C
R127	4C	C138	5C
R128	4B	C139	5C
R129	4B	C141	5C
R130	5B	C142	5C
R131	3D	C143	5C
R132	4C	C144	5C
R133	5B	C147	3C
R134	5B	C148	4C
R135	5B	C149	4C
D POWER SUPPLY P.C.B.			
Q701	7B	R724	7C
Q702	7B	R725	7C
Q705	7C	R749	8C
Q711	8B	R753	8C
Q725	7C	R765	7C
D723	7C	R768	7B
D730	8C	C717	7C
D738	8C	C718	7C
D739	8C	C719	7B
D758	8C	C720	7B
W701B	7C	C722	7C
R720	7C	C734	8C
R723	7C		

D POWER SUPPLY P.C.B.

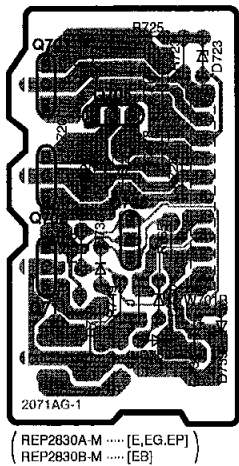

A | B | C | D | E | F

1
2
3
4
5
6
7
8

B OPERATION P.C.B.

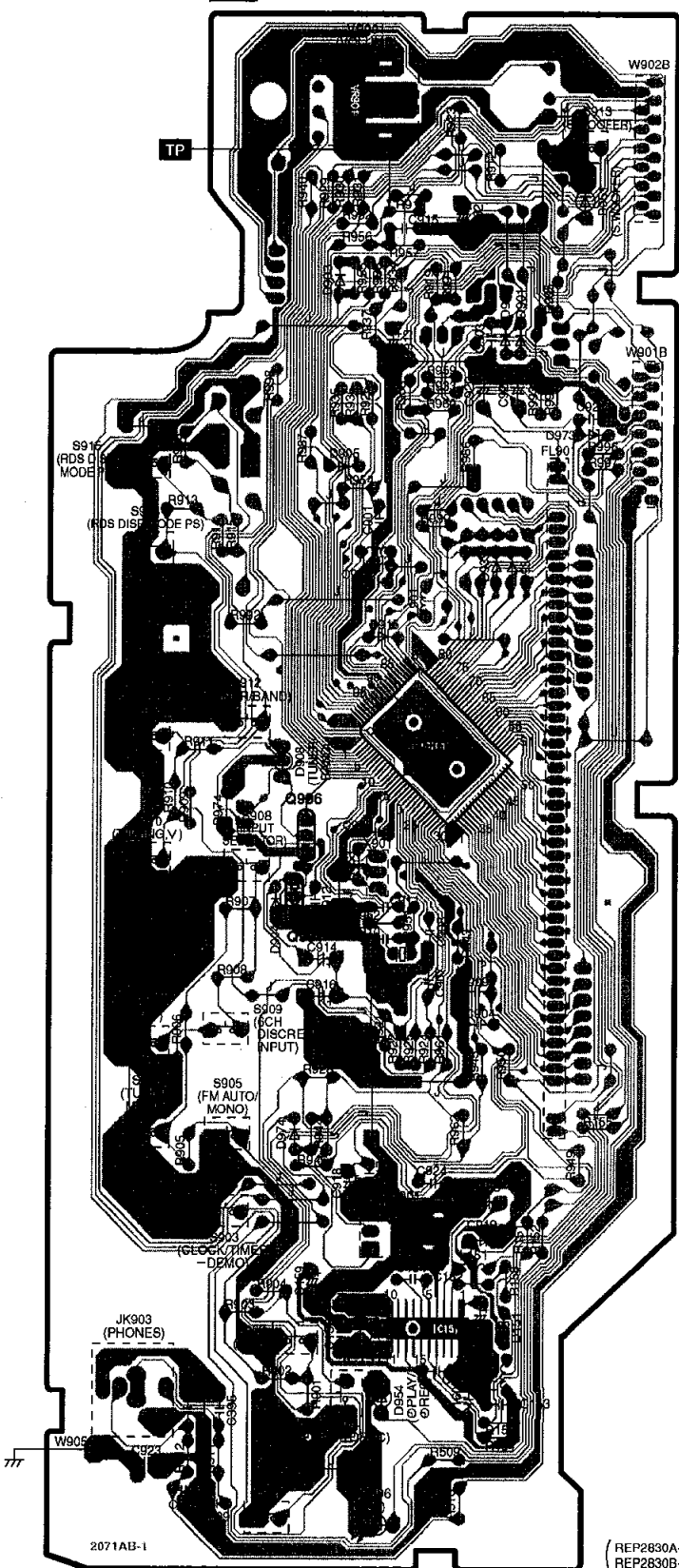

ELECTRICAL PARTS LOCATION

Ref. No.	Lo. No.	Ref. No.	Lo. No.	Ref. No.	Lo. No.
OPERATION P.C.B.					
IC151	7C	R509	8C	R959	3C
IC901	5C	R510	8C	R960	3C
Q901	5B	R511	8B	R961	6C
Q906	5B	R512	8B	R962	6C
D151	7C	R901	8B	R974	5B
D306	8C	R902	8B	R986	3C
D901	3C	R903	7B	R987	3B
D902	3C	R904	7B	R988	2C
D903	2B	R905	6B	R990	3C
D904	5B	R906	6B	R991	2C
D905	3B	R907	5B	R992	4B
D908	5B	R908	6B	R993	3C
D915	4C	R909	5B	R995	2C
D933	4C	R910	5B	R996	3D
D934	4C	R911	5B	R997	3D
D951	2D	R912	2C	R998	3B
D954	8C	R913	3B	C151	7C
D973	3D	R914	4B	C152	7C
D974	6B	R915	4B	C153	8C
VR901	2C	R916	3B	C154	7C
L151	7C	R918	2C	C155	8C
L152	8C	R919	2C	C156	7B
L901	4C	R921	6C	C157	7B
L902	4C	R922	6C	C158	7C
Z901	7C	R923	2C	C159	7B
X151	7C	R924	6C	C160	8C
X901	5C	R925	6C	C395	8B
X902	6C	R926	3C	C396	8B
FL901	3C	R928	6B	C509	8B
S901	8B	R929	2B	C510	8B
S902	7B	R930	2B	C901	4C
S903	7B	R931	2C	C902	2C
S904	8B	R932	2B	C903	3C
S905	6B	R933	3C	C904	6C
S906	6B	R934	2C	C907	6C
S907	6B	R935	3B	C908	5C
S908	5B	R936	3B	C909	6C
S909	6B	R937	3C	C910	5C
S910	5B	R939	4C	C911	5C
S911	5B	R940	2B	C912	5B
S912	4B	R943	5C	C913	3C
S913	2D	R944	6B	C914	6B
S914	4B	R945	6C	C915	2C
S915	3A	R946	7B	C916	6B
W901B	3D	R949	7D	C917	7C
W902B	2D	R950	6C	C918	7B
W905	8A	R951	5C	C919	7C
JK903	8A	R952	5C	C920	3C
R151	7C	R953	5C	C921	3D
R152	7C	R954	3B	C922	3C
R153	8C	R955	2B	C923	8B
R154	8C	R956	2B	C924	7C
R155	6D	R957	2C	C925	5C
R158	7C	R958	3C	C926	4C

2071AB-1

(REP2830A-M[E,EG,EP])
(REP2830B-M[EB])

A | B | C | D | E | F

1
2
3
4
5
6
7
8

C MAIN P.C.B.

To SOUND PROCESSOR

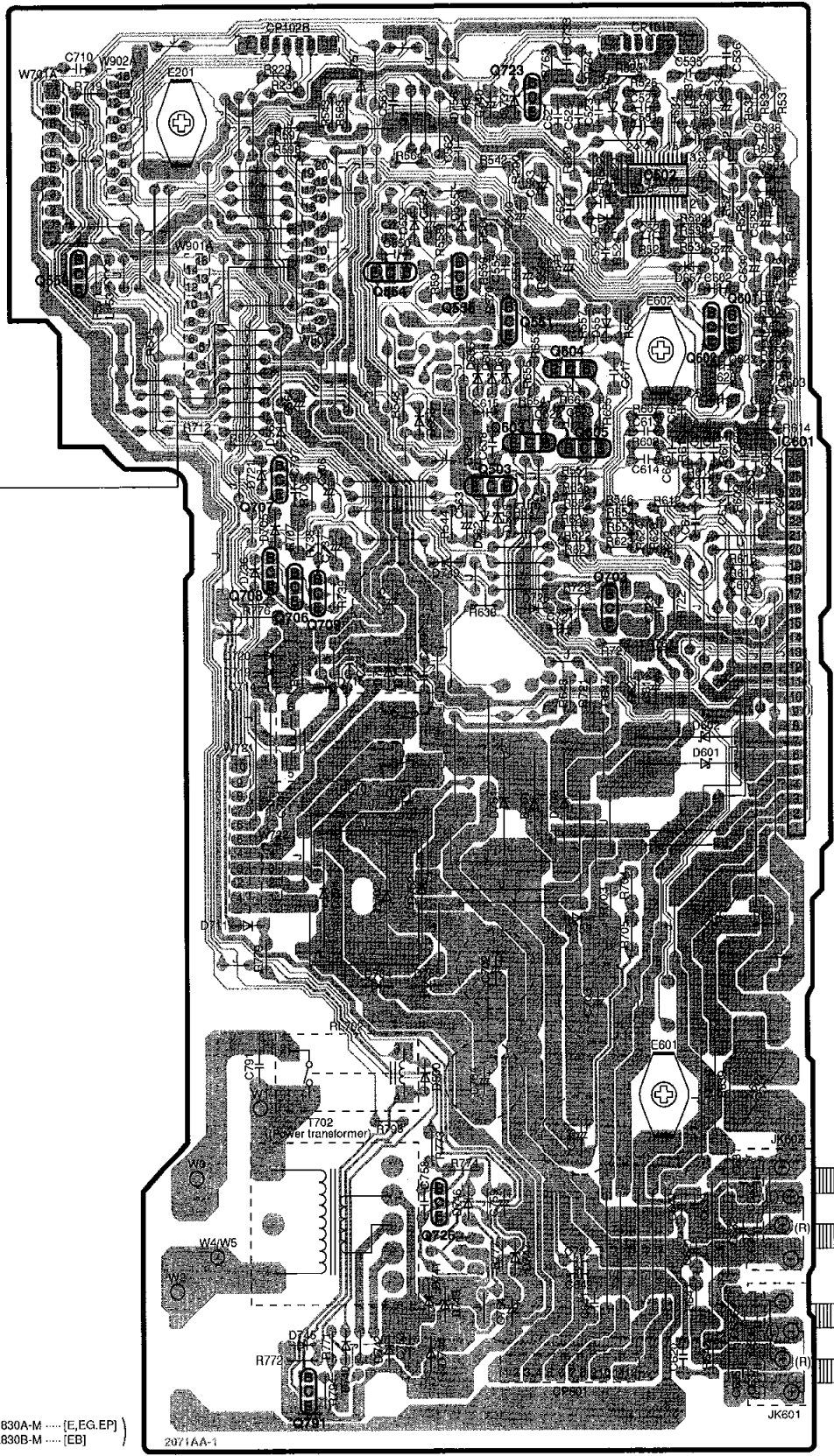

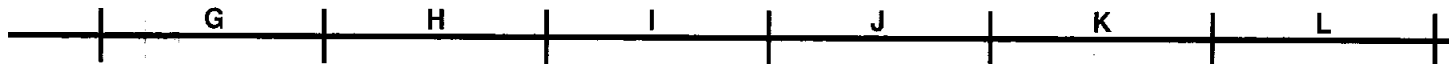

■ ELECTRICAL PARTS LOCATION

Ref. No.	Lo. No.	Ref. No.	Lo. No.	Ref. No.	Lo. No.	Ref. No.	Lo. No.	Ref. No.	Lo. No.	Ref. No.	Lo. No.
■ MAIN P.C.B.											
IC502	2E	D736	4C	R526	2E	R616	4F	R794	8C	C619	4D
IC601	4F	D737	2D	R527	2F	R617	2F	R795	7D	C620	8E
Q503	3D	D740	8D	R528	2F	R618	2F	C521	2E	C621	7E
Q551	3D	D741	8D	R529	2E	R619	4E	C522	2E	C622	3E
Q554	2D	D742	8D	R530	2E	R620	4E	C523	2E	C623	3E
Q555	2D	D743	8D	R531	2F	R621	4E	C524	2E	C628	3E
Q558	2B	D744	8D	R532	2F	R622	4E	C525	2E	C629	3F
Q601	3F	D745	8C	R533	2F	R623	4E	C526	2E	C631	7F
Q602	3E	D746	7D	R534	2E	R624	4E	C527	2E	C632	7F
Q603	3E	D747	7D	R535	2F	R625	4E	C528	2E	C633	7F
Q604	3E	D749	4D	R538	2E	R626	4E	C529	2F	C634	7F
Q605	3E	D751	5D	R539	2E	R627	5E	C530	2F	C635	8F
Q703	4E	D752	6D	R542	2D	R628	3E	C531	2E	C636	8F
Q706	4C	D753	6E	R543	2C	R629	3D	C532	2E	C637	8F
Q707	3C	D754	6D	R544	4D	R637	4D	C533	2E	C638	8F
Q708	4C	D755	6D	R545	3C	R638	4D	C534	2F	C639	7E
Q709	4C	D756	2D	R546	4E	R639	7F	C535	1E	C640	7E
Q723	2E	D757	1D	R548	3D	R640	6F	C536	1F	C641	8E
Q726	7D	L153	2B	R551	3E	R641	8E	C537	2E	C642	8E
Q791	8C	L601	7F	R552	4E	R642	8E	C538	2F	C647	3E
D500	7D	L602	6E	R553	4E	R647	5E	C539	2E	C648	3E
D501	2E	T702	7C	R554	4E	R648	5E	C540	2D	C649	4F
D502	2E	RL701	5D	R555	3E	R653	3E	C541	2E	C650	4F
D503	2F	RL702	6D	R556	2E	R654	3E	C542	2F	C701	7E
D504	2F	W3	7C	R557	3E	R655	3E	C550	2D	C702	6D
D551	3E	CP101B	1E	R558	2D	R656	3D	C551	2D	C703	6E
D552	2D	CP102B	1C	R559	2D	R661	3E	C552	2D	C704	7D
D555	2D	CP601	8E	R561	2D	R703	6E	C553	3E	C706	4C
D558	4D	W1	7C	R563	2D	R704	6E	C554	2D	C707	4C
D562	4D	W2	8C	R564	2D	R705	6E	C561	2D	C709	4D
D563	3C	W4/W5	7C	R570	2D	R707	4C	C562	2D	C710	1B
D601	5E	W501	2C	R571	2B	R708	4C	C563	4D	C714	5C
D602	5E	W701A	2B	R572	3C	R712	3C	C564	3C	C715	4D
D603	3D	W721	5C	R591	2D	R719	1B	C601	2F	C721	4E
D604	3D	W722	5C	R597	2C	R721	5E	C602	2E	C723	4E
D605	3D	W901A	3C	R598	2C	R722	4E	C603	3F	C731	4D
D657	2E	W902A	2B	R601	3F	R727	4E	C604	3F	C732	7E
D658	3D	JK601	8F	R602	3F	R729	4E	C605	3E	C733	1E
D701	5E	JK602	7F	R603	2F	R738	4C	C606	3E	C737	4D
D702	6D	E201	2C	R604	3F	R739	4C	C607	3F	C740	2D
D703	5E	E601	7E	R605	3F	R763	1E	C608	3F	C741	5C
D704	6C	E602	3E	R606	3F	R764	1E	C609	4F	C753	8D
D705	4C	R229	1C	R607	3E	R766	4C	C610	4E	C754	8D
D711	6C	R230	1C	R608	3E	R767	4E	C611	4F	C758	7D
D715	5C	R289	2E	R609	4F	R771	8C	C612	4E	C759	7D
D717	4D	R290	2D	R610	3E	R772	8C	C613	3E	C761	5D
D718	4D	R521	2E	R611	4F	R773	7D	C614	3E	C791	6C
D719	4C	R522	2E	R612	4E	R774	7D	C615	3D		
D720	4C	R523	1E	R613	3F	R776	4C	C616	5E		
D721	3C	R524	2E	R614	3F	R777	7D	C617	3E		
D725	4E	R525	1E	R615	3E	R779	6C	C618	3D		

A B C D E F

1

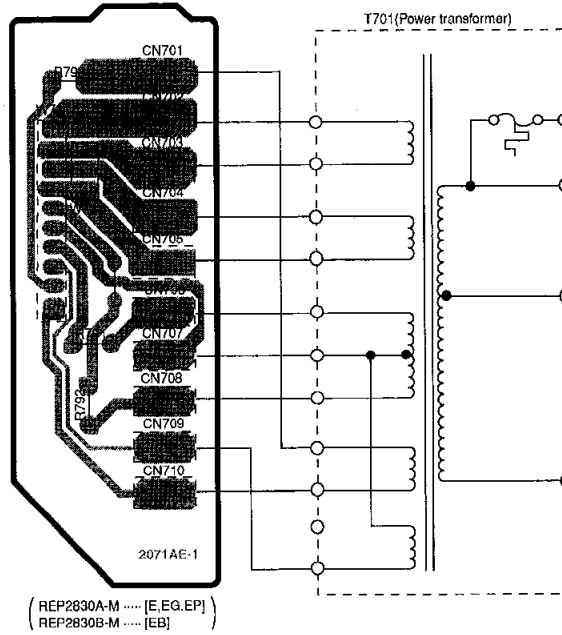
F POWER TRANSFORMER (A) P.C.B.



(REP2830A-M [E,EG,EP])
(REP2830B-M [EB])

G POWER TRANSFORMER (B) P.C.B.

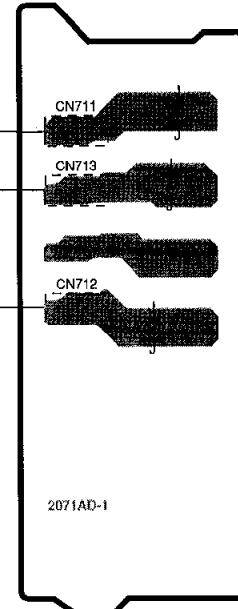

(REP2830A-M [E,EG,EP])
(REP2830B-M [EB])

5

E SPEAKER TERMINAL P.C.B.

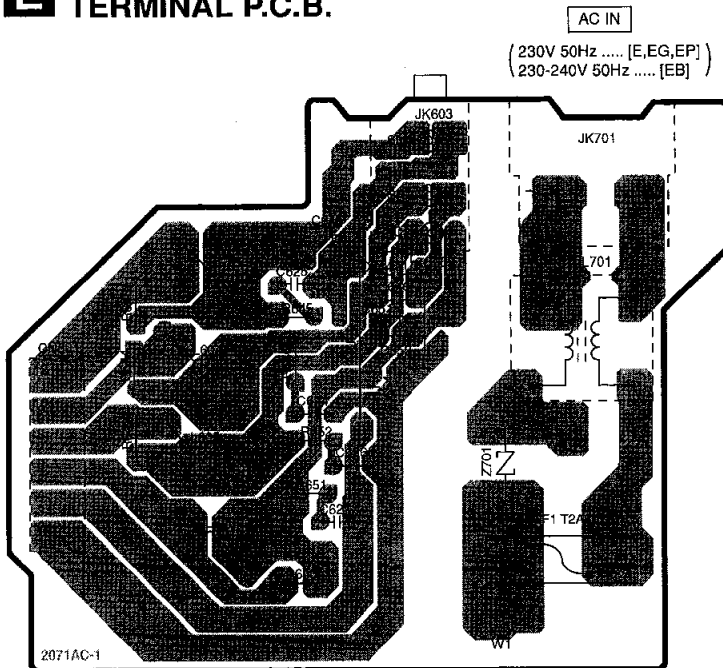

(REP2830A-M [E,EG,EP])
(REP2830B-M [EB])

ELECTRICAL PARTS LOCATION



Ref. No.	Lo. No.	Ref. No.	Lo. No.
SPEAKER TERMINAL P.C.B.			
L603	6B	R646	7B
L604	7B	R649	7A
L605	7B	R650	8B
L606	7B	R651	7B
L701	6C	R652	7B
Z701	7C	C624	7B
CN601	7A	C625	6B
W1	8C	C626	7B
W2	7C	C627	7B
JK603	6C	C643	6B
F1	7C	C644	6C
JK701	6D	C645	6B
FC1	7D	C646	6C
FC2	7C	C651	6C
R643	6A	C652	6C
R644	7A	C653	6C
R645	6B	C654	7C
POWER TRANSFORMER(A) P.C.B.			
CN701	2B	CN709	3B
CN702	2B	CN710	4B
CN703	2B	W721	2B
CN704	2B	W722	2B
CN705	3B	R791	3B
CN706	3B	R792	3B
CN707	3B	R793	2B
CN708	3B		
POWER TRANSFORMER(B) P.C.B.			
CN711	2E	W3	2E
CN712	3E	W4	3E
CN713	2E	W5	2E

8

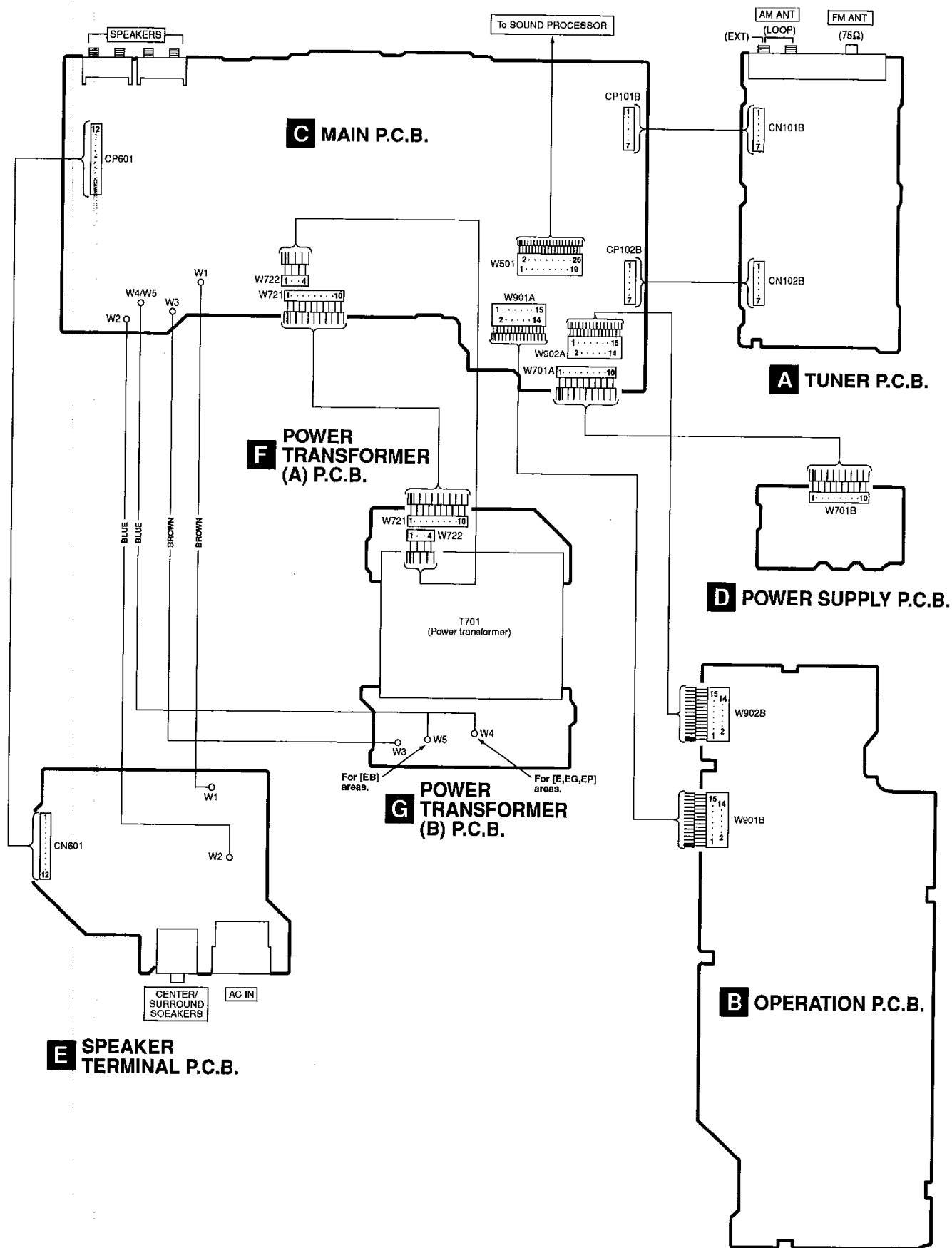
Wiring Connection Diagram

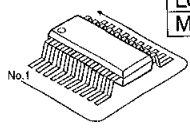
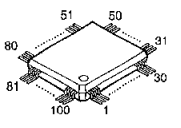
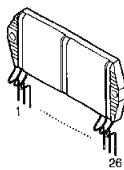

■ Type Illustration of IC's, Transistors and Diodes

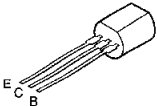
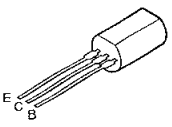
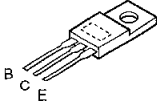
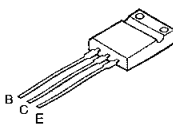
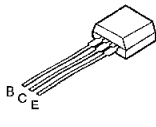
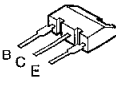
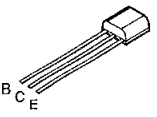
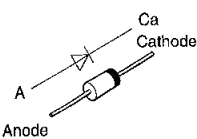
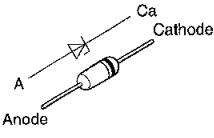
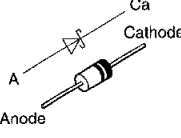
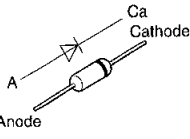
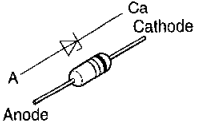
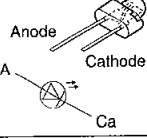
 <table border="1" data-bbox="297 199 545 304"> <tr> <td>LA1833MN-TLM</td> <td>24PIN</td> </tr> <tr> <td>LC72131MDTLM</td> <td>20PIN</td> </tr> <tr> <td>LC72721NMTLM</td> <td>20PIN</td> </tr> <tr> <td>M62456FPE1</td> <td>24PIN</td> </tr> </table>	LA1833MN-TLM	24PIN	LC72131MDTLM	20PIN	LC72721NMTLM	20PIN	M62456FPE1	24PIN	<p>LC8A524A5K01</p> 	<p>RSN311W64</p> 	 <p>2SC2787LTA 2SC3311ARSTA UN4111TA UN4211TA UN4212TA</p>		
LA1833MN-TLM	24PIN												
LC72131MDTLM	20PIN												
LC72721NMTLM	20PIN												
M62456FPE1	24PIN												
<p>2SB621AQRSTA 2SD592AQRSTA</p> 	<p>2SC3940AQSTA</p> 	<p>2SB1548PQAU 2SD2374PQAU</p> 	<p>2SB1417PQTA</p> 	<p>2SD2144STA</p> 	<p>2SD1859QRTV2</p> 								
<p>2SA1995RSTA 2SC5398RSTA</p> 	<p>1N5402BF RL1N4003N02</p> 	 <p>MA4091HTA MA4100MTA MA4140MTA MA4150HTA MA4180LTA MA4300MTA</p>		<p>SB360L6508</p> 	<p>MA165TA MA700TA 1SS291TA</p> 								
 <p>MA4033MTA MA4051MTA MA4068MTA MA4082LTA</p>		<p>LNJ301MPUJAD LNJ801TPSJAD LNJ401NPYJA</p> 											

Terminal Function of IC's

● IC901 (LC8A524A5K01) : System Control/ FL Drive

Pin No.	Terminal Name	I/O	Function
1	CHECK	O	Clock check signal output
2	LC72 DI	O	PLL data signal output for IC102
3	LC72 CE	O	Chip enable signal output for IC102
4	LC72 DO/ ST	I	IF count data/stereo detect signal input for IC102
5	LC72 CK	O	Clock signal output for IC102
6	SW LV1	O	LEVEL 1 signal output for IC502
7	SW LV2	O	LEVEL 2 signal output for IC502
8	SW MUT	O	Muting signal output for IC502
9	SEL TUNER	-	Tuner select signal output (Not used, open)
10	SEL/ TUNER	O	Tuner select signal output ("L" = Tuner)
11	AC IN	I	Power failure detect signal input
12	RESET	I	Reset signal input
13	X IN	I	Oscillator connected terminal (32.7 kHz)
14	X OUT	O	
15	V _{SS}	-	GND terminal
16	XC IN	I	Oscillator connected terminal (6 MHz)
17	XC OUT	O	
18	V _{DD1}	I	Power supply terminal
19	KEY TU	I	Operation key signal input (TUNER, TIMER, AMP.section)
20	KEY KARAOKE	I	Operation key signal input (KARAOKE section)
21	SH REQ	I	Request signal input for sound processor
22	NC(GND)	-	Not used, connected to GND
23	VR JOGB	I	Volume control signal input
24	VR JOGA		
25	MIC DET	I	Microphone connecting detect signal input
26	HP SW	I	Headphones connecting detect signal input
27	RDS CLK	I	RDS clock signal input
28	RDS DATA	I	RDS data signal input
29	REMOCON	I	Remote control signal input

Pin No.	Terminal Name	I/O	Function
30~41	12G~1G	O	Grid signal output
42~45	P33~P30	O	Segment signal output
46	V _{DD3}	I	Power supply terminal
47~50	P29~P26	O	Segment signal output
51	-VP	I	Power supply terminal (negative)
52~71	P25~P6	O	Segment signal output
72	V _{DD4}	I	Power supply terminal
73~77	P5~P1	O	Segment signal output
78	REGIN0	I	Area select signal input
79	REGIN1	I	Area select signal input
80	STANDBY	O	LED (STAND BY) drive signal output
81	TIMER	O	LED (TIMER) drive signal output
82	S.W LED	O	LED (S.WOOFER) drive signal output
83	LOUNGE	O	LED (LOUNGE) drive signal output
84	CHORUS	O	LED (CHORUS) drive signal output
85	MUTE	O	Muting signal output
86	POWER	O	Power control signal output
87	/ECO	O	ECO signal output
88	NC	-	Not used, open
89	V _{SS2}	-	GND terminal
90	V _{DD2}	I	Power supply terminal
91~93	NC	-	Not used, open
94	SH CS	O	Chip select signal output to Sound processor
95	SH DO	O	Serial communication signal to Sound processor (Data signal output)
96	SH DI	I	Serial communication signal to Sound processor (Data signal input)
97	SH CK	I	Serial communication signal to Sound processor (Clock signal input)
98	E DET	I	Unusual condition detect terminal ("L": Unusual)
99	CR TIMER	I/O	TIME CONSTANT terminal
100	SD	I	Station detector signal input for tuner circuit

Block Diagram

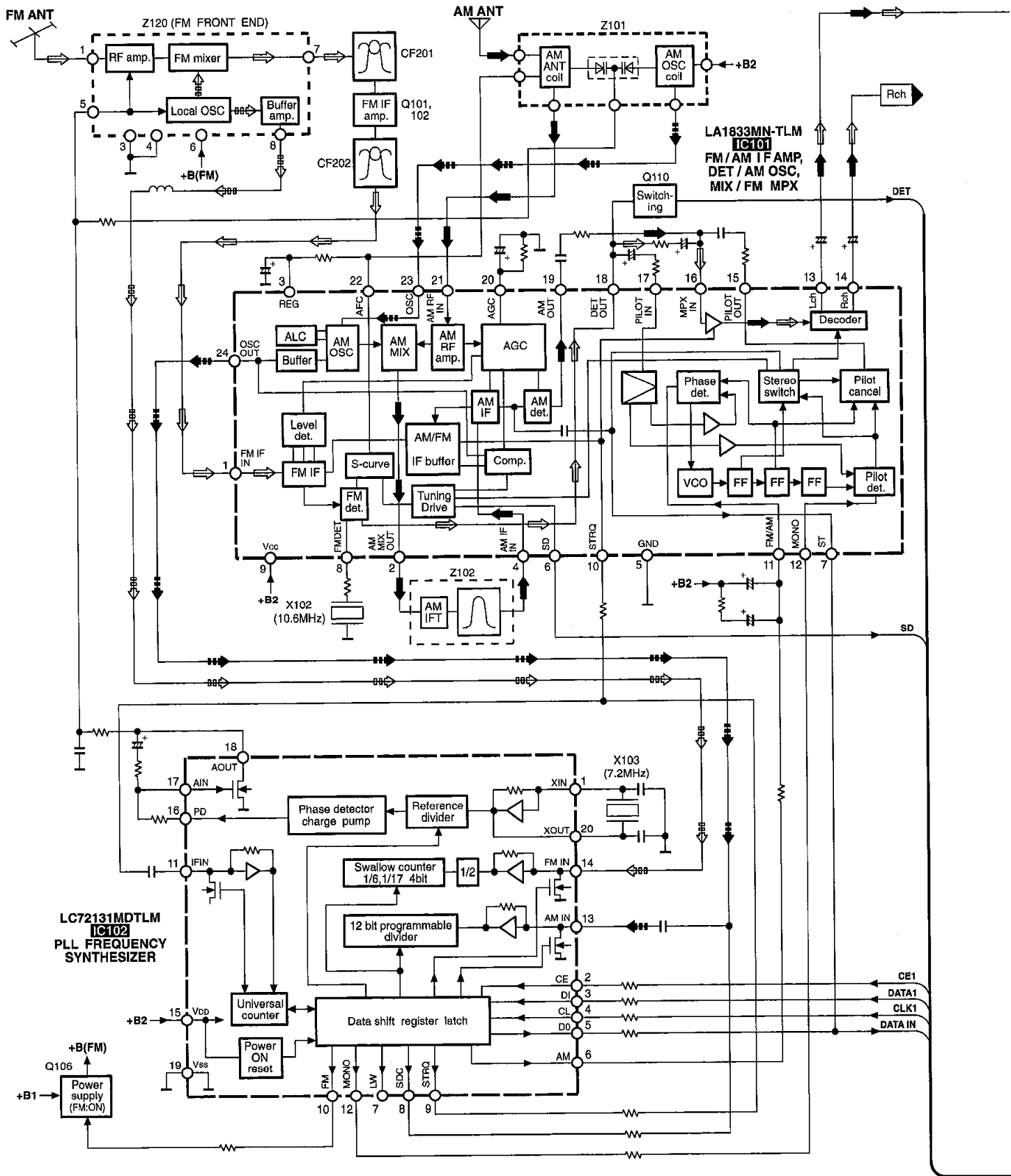

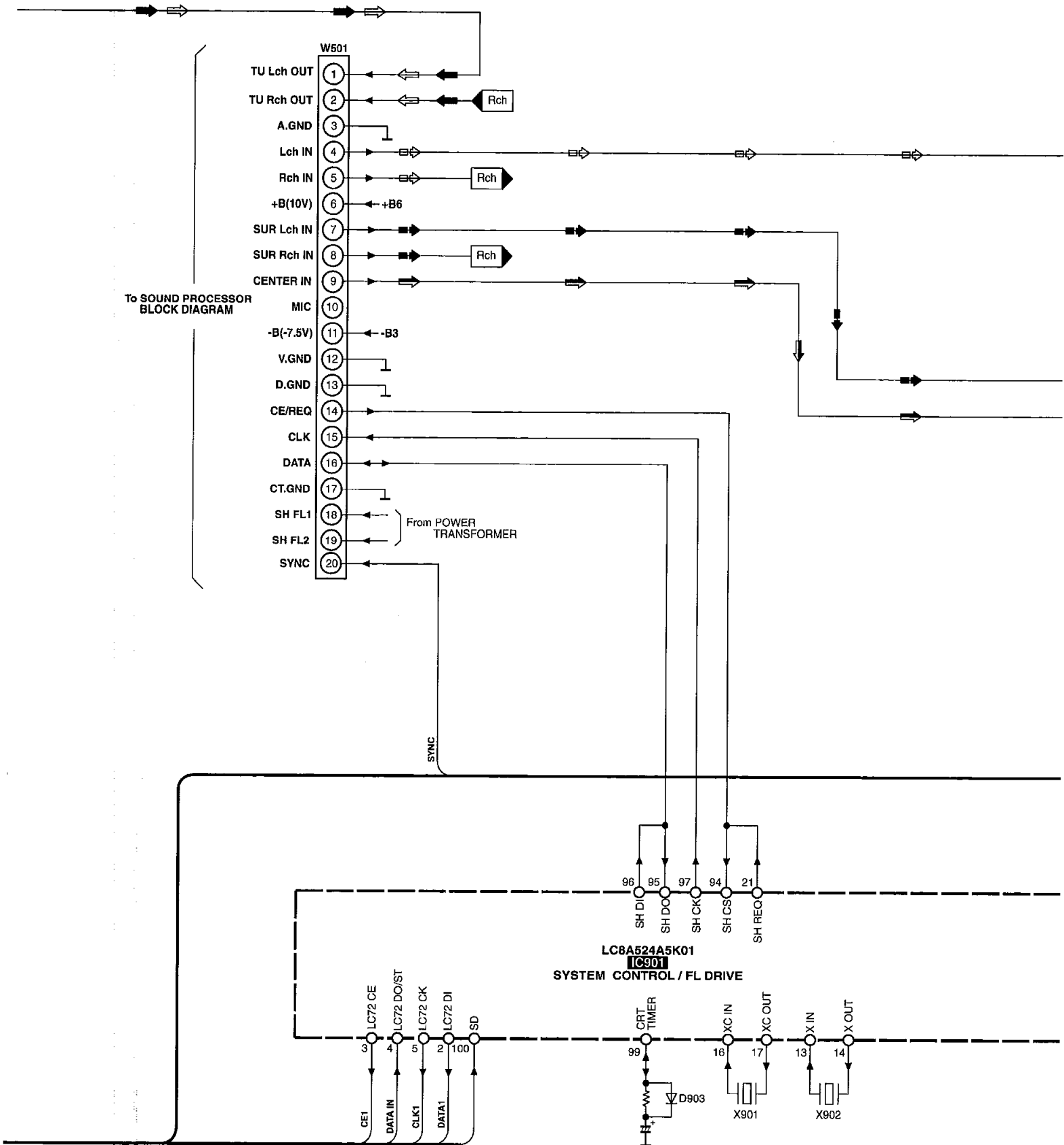

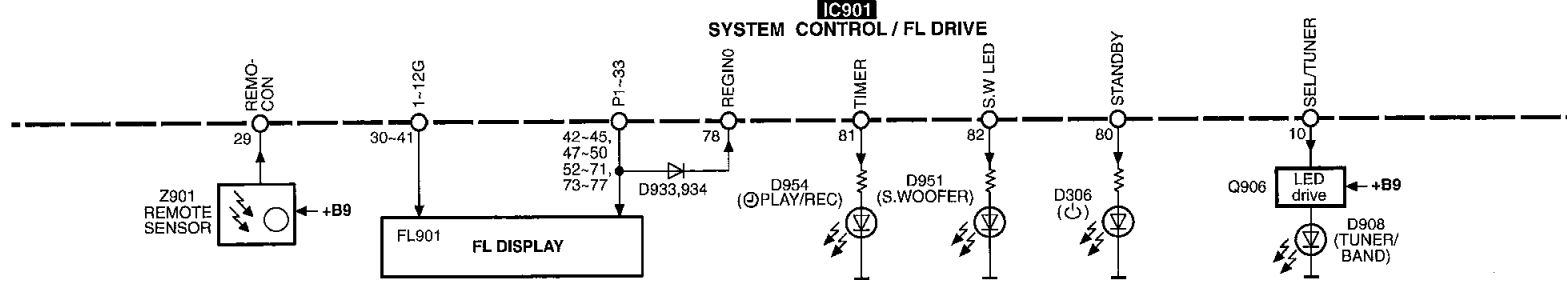
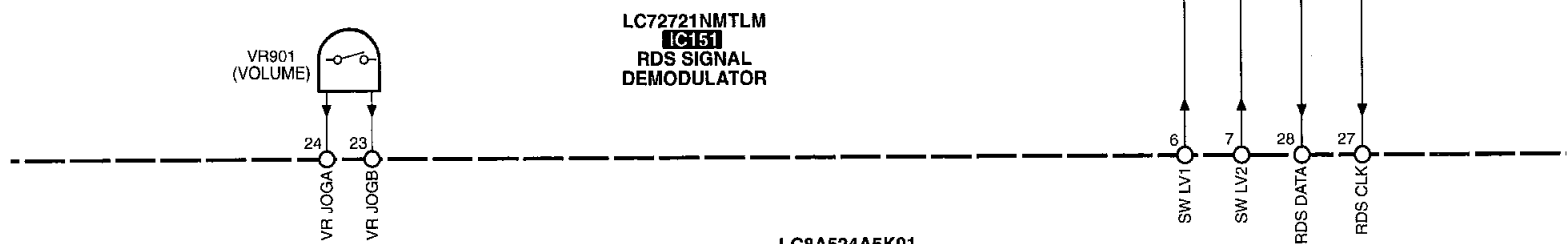
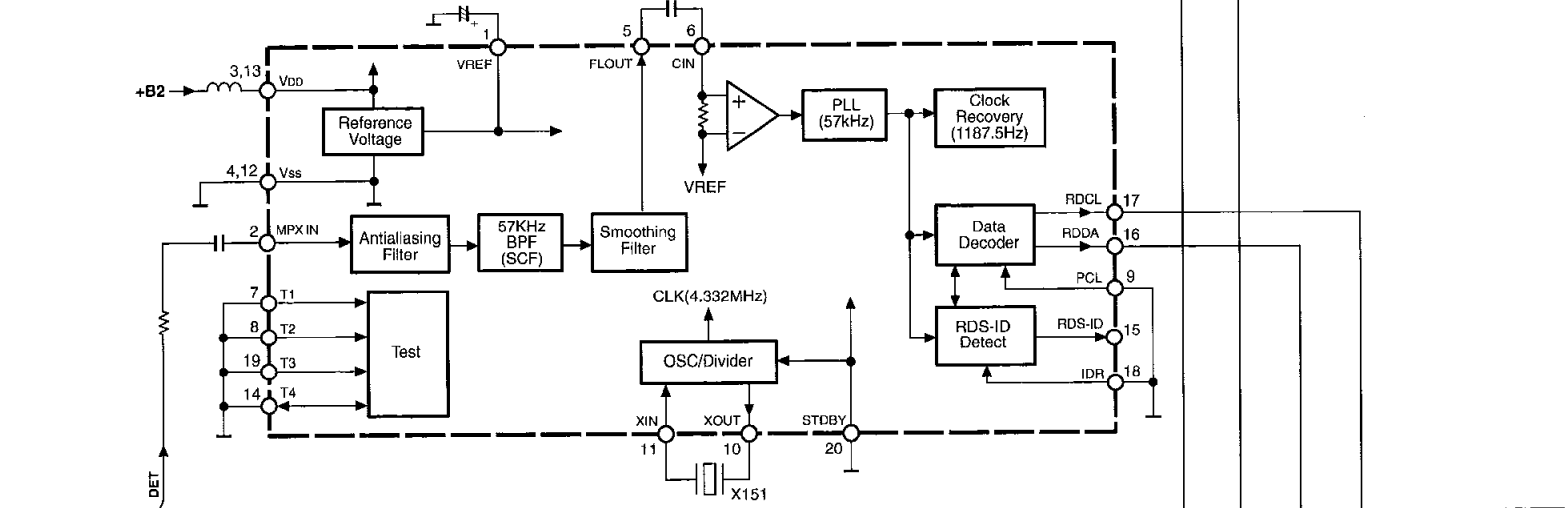
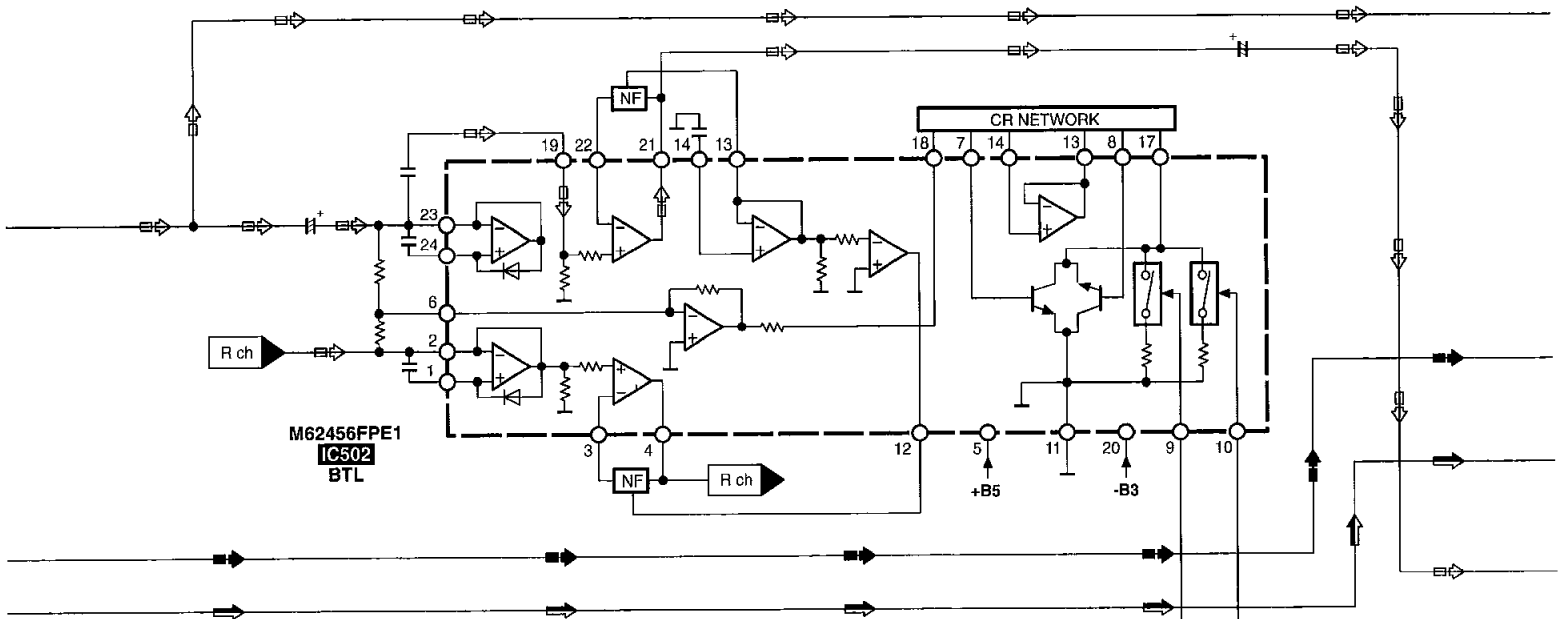

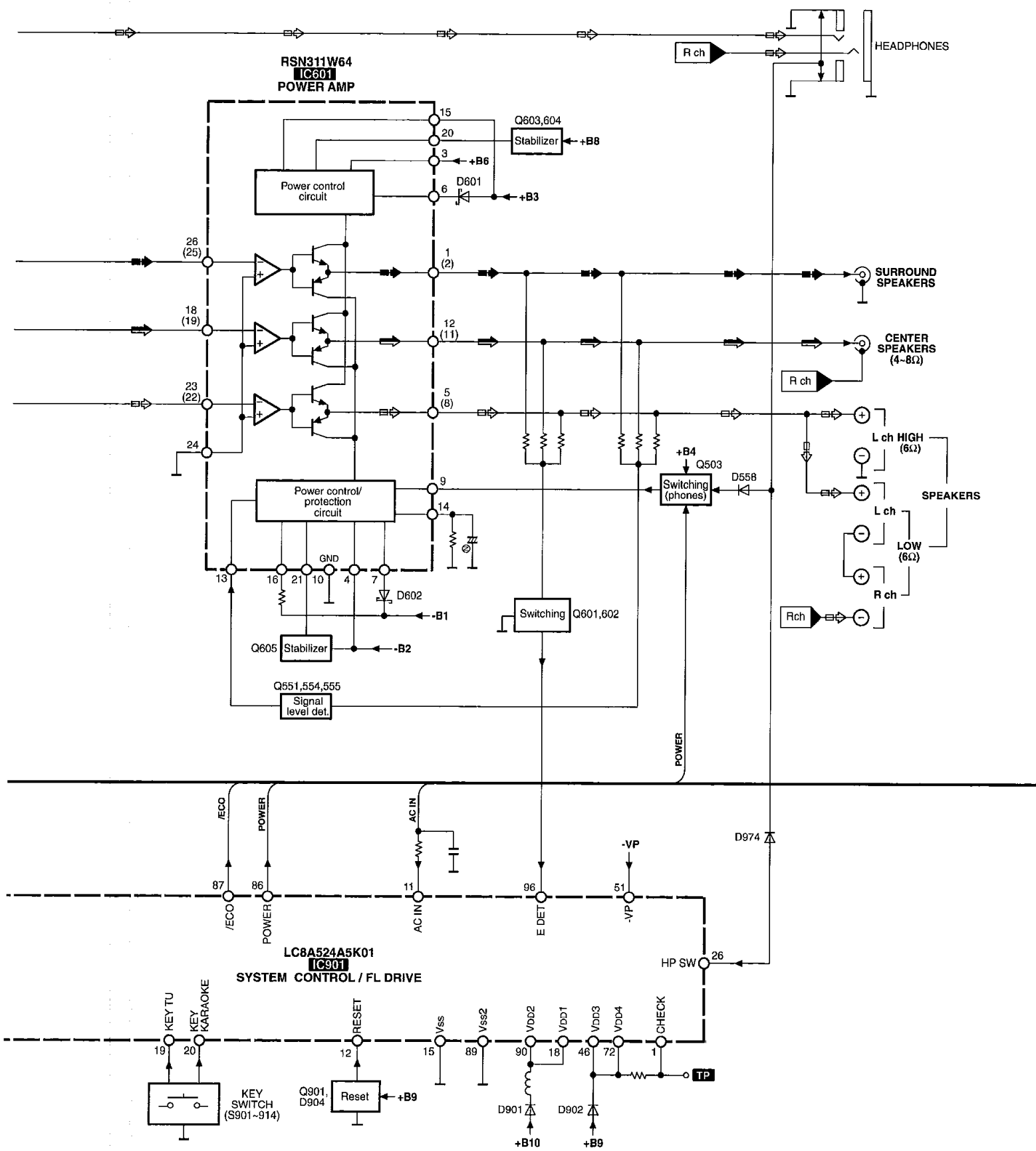

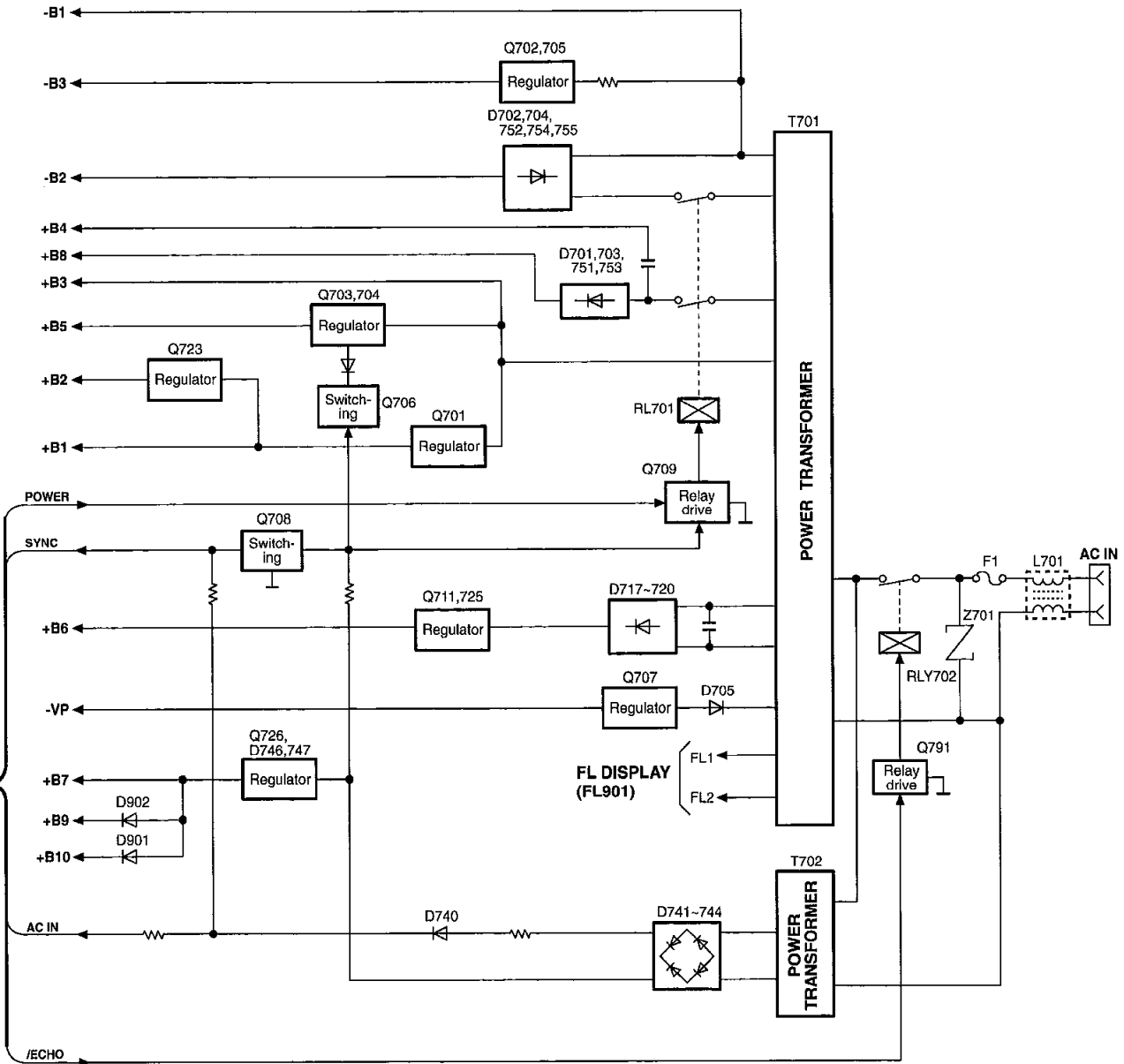
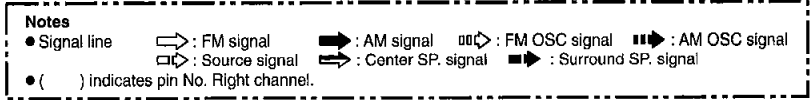

■ Replacement Parts List

Notes: * Important safety notice:

Components identified by Δ mark have special characteristics important for safety. Furthermore, special parts which have purposes of fire-(resistors), etc. are used. When replacing any of components, be sure to use only manufacturer's specified parts shown in the parts list.

* The parenthesized indications in the Remarks columns specify the areas. (Refer to the cover page for area.)

* ALL parts are supplied by MESA.

* The "<IA> <IB> <IC> <ID> <IE>" marks in Remarks indicate language of operating instructions.

<IA>: Spanish, Swedish

<IB>: German, Italian, French

<IC>: Dutch, Danish

<ID>: English

<IE>: Russian, Czech, Polish

Ref.No.	Part No.	Part Name & Description	Pcs	Remarks
1	RKM0395-S	CABINET	1	
2	RHD30007-K1	SCREW	4	
3	XTBS3+10JFZ1	SCREW	1	
4	REX0967	WIRE ASS'Y	1	
5	RMZ0339	ZNR COVER	1	
6	RGW0317-S1	KNOB,VOLUME	1	
7	RHN90001	NUT	1	
8	RKA0106-N	FOOT RING	4	
9	RKF0589-K	BACK GRILL	1	
10	RKW0581-V	FL WINDOW	1	
11	RMN0427	CABLE HOLDER	1	
12	RLBT4001-N	FERRITE CORE	1	
13	RYP0915-S	FRONT PANEL	1	
13-1	RGB0025-A	TECHNICS BADGE	1	
14	SHG1854	RUBBER	4	
15	XTB3+10JFZ	SCREW	10	
16	XTB3+8JFZ	SCREW	13	
17	XTW3+15T	SCREW	2	
18	XTBS3+8JFZ1	SCREW	2	
A1	RAK-EHA16WH	REMOTE CONT.TRANSMITTER	1	
A1-1	RKK0123-H	BATTERY COVER	1	
A2	REE0393	SPEAKER CORD	2	
A3	REE0853	SPEAKER CORD	2	
A4	RJA0019-X	AC POWER SUPPLY CORD	1	(E,EG,EP)
Δ A4	RJA0053-2X	AC POWER SUPPLY CORD	1	(EB)
A5	RQA0117	WARRANTY CARD	1	(E,EG,EB)
A6	RQCA0669	QUICK REFERENCE GUIDE	1	(EB)
A7	RQCB0169	SERVICE CENTER LIST	1	(E,EG,EB)
A8	RQT4969-E	OPERATING INSTRUCTIONS	1	(E)<IA>
A8	RQT4967-1D	OPERATING INSTRUCTIONS	1	(EG)<IB>
A8	RQT4968-1H	OPERATING INSTRUCTIONS	1	(EG)<IC>
A8	RQT4970-B	OPERATING INSTRUCTIONS	1	(EB,EP)<ID>
A8	RQT4971-R	OPERATING INSTRUCTIONS	1	(EP)<IE>
A9	RSA0007	FM INDOOR ANTENNA	1	
A10	RSA0022-J	AM LOOP ANTENNA	1	
A11	SJP9009	ANT ADAPTOR	1	(EB)
C101	ECBT1C103NS5	16V 0.01U	1	
C102	ECEA1CKS101	16V 100U	1	
C103	ECBT1C103NS5	16V 0.01U	1	
C104,05	ECBT1H102KB5	50V 1000P	2	
C106	ECBT1C103NS5	16V 0.01U	1	
C107	ECBT1H473ZF5	50V 0.047U	1	
C108	ECBT1H8R2KC5	50V 8.2P	1	
C109	ECBT1H102KB5	50V 1000P	1	
C110	ECBT1C103NS5	16V 0.01U	1	
C111	ECEA1EKS4R7	25V 4.7U	1	
C112	ECBT1C103NS5	16V 0.01U	1	
C113	ECBT1H102KB5	50V 1000P	1	
C114	RCE1HKA3R3BG	50V 3.3U	1	
C115	ECEA1EKS4R7	25V 4.7U	1	
C116	ECFR1C333KR	16V 0.033U	1	
C117,18	ECFR1C183KR	16V 0.0018U	2	
C119	ECQP1391JZ	100V 390P	1	
C120	RCE1CKA100BG	16V 10U	1	
C121	RCE1HKAR47BG	50V 0.47U	1	

Ref.No.	Part No.	Part Name & Description	Pcs	Remarks
C122,23	ECEA1HKS010	50V 1U	2	
C124	ECBT1H101KB5	50V 100P	1	
C125	ECEA1CKS220	16V 22U	1	
C126	ECBT1H473ZF5	50V 0.047U	1	
C127	ECEA1CKS220	16V 22U	1	
C129,30	ECEA0JKS101	6.3V 100U	2	
C131	ECBT1H101KB5	50V 100P	1	
C132	ECBT1H102KB5	50V 1000P	1	
C133,34	ECBT1H270JU5	50V 27P	2	
C136	ECBT1H102KB5	50V 1000P	1	
C137	ECFR1E472KR	25V 4700P	1	
C138	ECBT1C103KS5	16V 0.01U	1	
C139	ECFR1E472KR	25V 4700P	1	
C141,42	ECEA1HKS010	50V 1U	2	
C143,44	ECBT1C472KR5	16V 4700P	2	
C147	ECBT1H102KB5	50V 1000P	1	
C148	ECBT1C103NS5	16V 0.01U	1	
C149	ECBT1H104ZF5	50V 0.1U	1	
C151	RCE1CKA100BG	16V 10U	1	
C152	ECBT1H331KB5	50V 330P	1	
C153	ECBT1H102KB5	50V 1000P	1	
C154	ECBT1H561KB5	50V 560P	1	
C155	ECBT1H102KB5	50V 1000P	1	
C156,57	ECBT1H470J5	50V 47P	2	
C158,59	ECEA0JKS470	6.3V 47UF	2	
C160	ECBT1H102KB5	50V 1000P	1	
C395,96	ECBT1H473ZF5	50V 0.047U	2	
C509,10	ECBT1E103ZF	25V 0.01U	2	
C521	ECQV1H473JM3	50V 0.047U	1	
C522	ECQV1H683JM3	50V 0.068U	1	
C523,24	ECBT1H101KB5	50V 100P	2	
C525	ECQV1H563JM3	50V 0.056U	1	
C526	ECQV1H683JM3	50V 0.068U	1	
C527,28	ECBT1H101KB5	50V 100P	2	
C529,30	RCE1CKA100BG	16V 10U	2	
C531	ECQV1H823JZ	50V 0.082U	1	
C532	ECBT1E103ZF	25V 0.01U	1	
C533	ECEA1EKS4R7	25V 4.7U	1	
C534	RCE1AKA330BG	10V 33U	1	
C535	ECQV1H683JM3	50V 0.068U	1	
C536	ECQV1H393JM3	50V 0.039U	1	
C537	ECBT1H104KB5	50V 0.1U	1	
C538	ECQV1H154JM3	50V 0.15U	1	
C539	ECBT1C472KR5	16V 4700P	1	
C540,41	ECEA0JKS470	6.3V 47U	2	
C542	ECBT1E103ZF	25V 0.01U	1	
C550	ECBT1C103NS5	16V 0.01U	1	
C551	ECEA1HKS2R2	50V 2.2U	1	
C552	ECBT1E103ZF	25V 0.01U	1	
C553	RCE1HKAR47BG	50V 0.47U	1	
C554	ECEA1AKS221	10V 220U	1	
C561,62	ECQV1H823JZ	50V 0.082U	2	
C563	ECEA0JKS101	6.3V 100U	1	
C564	RCE1CKA100BG	16V 10U	1	
C601,02	RCE1CKA100BG	16V 10U	2	
C603-08	ECBT1H471KB5	50V 470P	6	
C609,10	ECBT1H220JC5	50V 22P	2	
C611,12	ECBT1H150JC5	50V 15P	2	
C613,14	ECBT1H220JC5	50V 22P	2	
C615	ECKR1H103ZF5	50V 0.01U	1	
C616	ECEA1HKNR47B	50V 0.47U	1	
C617,18	ECKR2H103ZU	500V 0.01U	2	
C619	ECBT1E103ZF	25V 0.01U	1	
C620,21	ECQV1H473JM3	50V 0.047U	2	
C622	ECA1HM101	50V 100U	1	
C623	ECBT1H104ZF5	50V 0.1U	1	
C624-27	ECQV1H473JM3	50V 0.047U	4	
C628	ECBT1H104ZF5	50V 0.1U	1	
C629	RCE1CKA100BG	16V 10U	1	
C631,32	ECBT1H473ZF5	50V 0.047U	2	
C633,34	ECBT1H102KB5	50V 1000P	2	
C635,36	ECBT1H473ZF5	50V 0.047U	2	
C637-44	ECBT1H102KB5	50V 1000P	8	
C645,46	ECBT1H473ZF5	50V 0.047U	2	
C647-50	ECBT1H102KB5	50V 1000P	4	
C651	ECBT1H473ZF5	50V 0.047U	1	
C652-54	ECBT1H102KB5	50V 1000P	3	
Δ C701-04	ECA1VM472E	35V 4700U	4	

Ref.No.	Part No.	Part Name & Description	Pcs	Remarks
C706	RCE1VKA100BG	35V 10U	1	
C707	ECBT1E103ZF	25V 0.01U	1	
C709	ECBT1H104ZF5	50V 0.1U	1	
C710	ECBT1E103ZF	25V 0.01U	1	
C714	ECBT1H102KB5	50V 1000P	1	
△ C715	ECA1EM472	25V 4700U	1	
C717	ECEA1CK330	16V 33U	1	
C718	RCE1AKA101BG	10V 100U	1	
C719,20	ECBT1H473KB5	50V 0.047U	2	
C721,22	RCE1AKA101BG	10V 100U	2	
C723	ECBT1E103ZF	25V 0.01U	1	
C731	ECBT1H102KB5	50V 1000P	1	
C732	ECBT1E223ZF	25V 0.022U	1	
C733	ECBT1E103ZF	25V 0.01U	1	
C734	RCE1HKA3R3BG	50V 3.3U	1	
△ C737	ECA1HM101	50V 100U	1	
C740	RCE1CKA100BG	16V 10U	1	
C741	ECQE1104KF3	100V 0.1U	1	
C753	ECKR1H103ZF5	50V 0.01U	1	
△ C754	RCE1CM102BV	16V 1000U	1	
C758	ECBT1E103ZF	25V 0.01U	1	
C759	RCE1AKA470BG	10V 47U	1	
C761	ECQE1104KF3	100V 0.1U	1	
C791	ECKWRS102MBC	125V 1000P	1	
C901	ECBT1H102KB5	50V 1000P	1	
C902	RCE1AM102BV	10V 1000U	1	
C903,04	ECBT1E103ZF	25V 0.01U	2	
C907,08	ECBT1H471KB5	50V 470P	2	
C909	ECBT1H102KB5	50V 1000P	1	
C910	ECBT1H220JC5	50V 22P	1	
C911	ECBT1H180J5	50V 18P	1	
C912	ECBT1H104ZF5	50V 0.1U	1	
C913	RCE1CKA100BG	16V 10U	1	
C914	ECEA1HKS2R2	50V 2.2U	1	
C915	ECBT1E103ZF	25V 0.01U	1	
C916	EEAFC0J101B	6.3V 100U	1	
C917	ECBT1E103ZF	25V 0.01U	1	
C918	ECEA0JKS101	6.3V 100U	1	
C919,20	ECEA1HKS2R2	50V 2.2U	2	
C921	ECBT1H102KB5	50V 1000P	1	
C922	ECEA1VKA330B	35V 33U	1	
C923,24	ECBT1H104ZF5	50V 0.1U	2	
C925,26	ECBT1H102KB5	50V 1000P	2	
CF201	RLFFETNGD01L	CERAMIC FILTER	1	
CF202	RLFFETMGD01L	CERAMIC FILTER	1	
CN101B,2B	RJU100W07	CONNECTOR(7P)	2	
CN601	RJU057W012	CONNECTOR(12P)	1	
CN701-13	RJS1A1101T1	CONNECTOR(1P)	13	
CP101B,2B	RJT100W07	CONNECTOR(7P)	2	
CP601	RJT057W012-1	CONNECTOR(12P)	1	
△ D101	MA4051M	DIODE	1	
△ D151	MA4051M	DIODE	1	
D306	LNJ801TPSJAD	LED	1	
D500-04	MA165	DIODE	5	
D551,52	MA165	DIODE	2	
D555	MA4100M	DIODE	1	
D558	MA165	DIODE	1	
D562,63	MA165	DIODE	2	
D601,02	SB360L6508	DIODE	2	
D603	MA4180L	DIODE	1	
D604,05	MA4140M	DIODE	2	
D657,58	MA165	DIODE	2	
△ D701-04	1N5402BF	DIODE	4	
△ D705	RL1N4003N02	DIODE	1	
D711	RL1N4003N02	DIODE	1	
D715	MA165	DIODE	1	
△ D717-20	RL1N4003N02	DIODE	4	
△ D721	MA4300M	DIODE	1	
△ D723	MA4150M	DIODE	1	
△ D725	MA4082LTA	DIODE	1	
D730	MA4091H	DIODE	1	
D736	MA165	DIODE	1	
△ D737	MA4082LTA	DIODE	1	
D738-40	MA165	DIODE	3	

Ref.No.	Part No.	Part Name & Description	Pcs	Remarks
△ D741-44	RL1N4003N02	DIODE	4	
D745	MA4051M	DIODE	1	
D746	RL1N4003N02	DIODE	1	
△ D747	MA4068M	DIODE	1	
D749	MA165	DIODE	1	
△ D751,52	1N5402BF	DIODE	2	
△ D753-55	RL1N4003N02	DIODE	3	
D756,57	MA700TA	DIODE	2	
D758	MA165	DIODE	1	
D901,02	1SS291TA	DIODE	2	
D903,04	MA165	DIODE	2	
D905	1SS291TA	DIODE	1	
D908	LNJ301MPUJAD	LED	1	
D915	1SS291TA	DIODE	1	
D933,34	MA165	DIODE	2	
D951	LNJ301MPUJAD	LED	1	
D954	LNJ401NPFJA	DIODE	1	
△ D973	MA4033M	DIODE	1	
D974	MA165	DIODE	1	
△ F1	XBA2C20TB0	FUSE,T2A	1	
FL901	RSL0285-F	FL	1	
IC101	LA1833MN-TLM	IC	1	
IC102	LC72131MDTLM	IC	1	
IC151	LC72721NMTLM	IC	1	
IC502	M62456FPE1	IC	1	
△ IC601	RSN311W64	IC	1	
IC901	LC8A524A5K01	IC	1	
JK101	RJH5210M	JACK,ANTENNA	1	
JK601	RJR0054B	JACK,SPEAKER	1	
JK602	RJR0054C	JACK,SPEAKER	1	
JK603	RJH2308	JACK,SPEAKER	1	
△ JK701	SJS9236	JACK,AC INLET	1	
JK903	RJU37TN02-C	JACK,HEADPHONE	1	
L101,02	ELESNR68MA	COIL	2	
L103	ELETR47MA9	COIL	1	
L151,52	ELEXT101KA9	COIL	2	
L153	RLQZP1R0KT-Y	COIL	1	
L601-06	RLQYR73MW1-0	COIL	6	
△ L701	RLQZ371	COIL	1	
L901	RLQA100JT-Y	COIL	1	
L902	RLQZP1R0KT-Y	COIL	1	
P1	RPF0139	PROTECTION COVER	1	
P2	RPG4397	PACKING CASE(RS)	1	
P2	RPG4396	PACKING CASE(SA)	1	
P2	RPG4398	PACKING CASE(SH)	1	
P2	RPG4399	PACKING CASE(SL)	1	
P3	RPN1195	PAD(RS)	1	
P3	RPN1194	PAD(SA)	1	
P3	RPN1196	PAD(SH)	1	
P3	RPN1197	PAD(SL)	1	
P4	RPG4400	PACKING CASE(SYSTEM)	1	(E)
P4	RPG4401	PACKING CASE(SYSTEM)	1	(EG)
P4	RPG4402	PACKING CASE(SYSTEM)	1	(EB)
P4	RPG4403	PACKING CASE(SYSTEM)	1	(EP)
P5	RPQ0951	PAD(SYSTEM)	1	
P6	SPP740-1	SHEET	1	
Q101,02	2SC2787FK	TRANSISTOR	2	
Q106	UN4111	TRANSISTOR	1	
Q110	2SC3311AR	TRANSISTOR	1	
Q503	2SC3327A	TRANSISTOR	1	
Q551	2SA1995RSTA	TRANSISTOR	1	
Q554	2SA1995RSTA	TRANSISTOR	1	
Q555	2SC3327A	TRANSISTOR	1	
Q558	UN4211	TRANSISTOR	1	
Q601,02	2SC5398RSTA	TRANSISTOR	2	
Q603,04	2SD1859QRTV2	TRANSISTOR	2	
Q605	2SB1417PQTA	TRANSISTOR	1	
△ Q701	2SD2374PQAU	TRANSISTOR	1	
△ Q702	2SB1548PQAU	TRANSISTOR	1	
△ Q703	2SD592AR	TRANSISTOR	1	
△ Q705	2SA1995RSTA	TRANSISTOR	1	

Ref.No.	Part No.	Part Name & Description	Pcs	Remarks
Q706	UN4211	TRANSISTOR	1	
△ Q707	2SB621A-R	TRANSISTOR	1	
Q708	UN4211	TRANSISTOR	1	
Q709	2SC3327A	TRANSISTOR	1	
△ Q711	2SB1548PQAU	TRANSISTOR	1	
△ Q723	2SC3940AQSTA	TRANSISTOR	1	
△ Q725	2SC5398RSTA	TRANSISTOR	1	
△ Q726	2SC3940AQSTA	TRANSISTOR	1	
Q791	2SC3327A	TRANSISTOR	1	
Q901	UN4212TA	TRANSISTOR	1	
Q906	UN4111	TRANSISTOR	1	
R102	ERDS2FJ472	1/4W 4.7K	1	
R103	ERDS2FJ101	1/4W 100	1	
R104	ERDS2FJ103	1/4W 10K	1	
R105	ERDS2FJ471	1/4W 470	1	
R106	ERDS2FJ474	1/4W 470K	1	
R107	ERDS2FJ331	1/4W 330	1	
R108	ERDS2FJ474	1/4W 470K	1	
R109	ERDS2FJ331	1/4W 330	1	
R110	ERDS2FJ102	1/4W 1K	1	
R111	ERDS2FJ391	1/4W 390	1	
R112	ERDS2FJ104	1/4W 100K	1	
R113	ERDS2FJ103	1/4W 10K	1	
R114	ERDS2FJ562	1/4W 5.6K	1	
R115	ERDS2FJ561	1/4W 560	1	
R116	ERDS2FJ102	1/4W 1K	1	
R117	ERDS2FJ683	1/4W 68K	1	
R118	ERDS2FJ332	1/4W 3.3K	1	
R119	ERDS2FJ103	1/4W 10K	1	
R120	ERDS2FJ473	1/4W 47K	1	
R121	ERDS2FJ223	1/4W 22K	1	
R122	ERDS2FJ272	1/4W 2.7K	1	
R123	ERDS2FJ683	1/4W 68K	1	
R124	ERDS2FJ271	1/4W 270	1	
R125,26	ERDS2FJ152	1/4W 1.5K	2	
R127	ERDS2FJ471	1/4W 470	1	
R128	ERDS2FJ820	1/4W 82	1	
R129	ERDS2FJ273	1/4W 27K	1	
R130	ERDS2FJ103	1/4W 10K	1	
R131	ERDS2FJ680	1/4W 68	1	
R132	ERDS2FJ103	1/4W 10K	1	
R133-37	ERDS2FJ102	1/4W 1K	5	
R138	ERDS2FJ103	1/4W 10K	1	
R139	ERDS2FJ332	1/4W 3.3K	1	
R140	ERDS2FJ472	1/4W 4.7K	1	
R141,42	ERDS2FJ102	1/4W 1K	2	
R143	ERDS2FJ223	1/4W 22K	1	
R145,46	ERDS2FJ104	1/4W 100K	2	
R151,52	ERDS2FJ102	1/4W 1K	2	
R153,54	ERDS2FJ104	1/4W 100K	2	
R155	ERDS2FJ121	1/4W 120	1	
R158	ERDS2FJ102	1/4W 1K	1	
R229,30	ERDS2FJ102	1/4W 1K	2	
R289,90	ERDS2FJ473	1/4W 47K	2	
R509-12	ERDS2FJ470	1/4W 47	4	
R521	ERDS2FJ433	1/4W 43K	1	
R522	ERDS2FJ333	1/4W 33K	1	
R523,24	ERDS2FJ153	1/4W 15K	2	
R525,26	ERDS2FJ333	1/4W 33K	2	
R527,28	ERDS2FJ101	1/4W 100	2	
R529	ERDS2FJ223	1/4W 22K	1	
R530	ERDS2FJ273	1/4W 27K	1	
R531	ERDS2FJ274	1/4W 270K	1	
R532	ERDS2FJ153	1/4W 15K	1	
R533	ERDS2FJ822	1/4W 8.2K	1	
R534,35	ERDS2FJ823	1/4W 82K	2	
R538	ERDS2FJ273	1/4W 27K	1	
R539	ERDS2FJ824	1/4W 820K	1	
R542,43	ERDS2FJ472	1/4W 4.7K	2	
R544	ERDS2FJ103	1/4W 10K	1	
R545	ERDS2FJ222	1/4W 2.2K	1	
R546	ERDS2FJ183	1/4W 18K	1	
R548	ERDS2FJ102	1/4W 1K	1	
R551	ERDS2FJ183	1/4W 18K	1	
R552	ERDS2FJ473	1/4W 47K	1	
R553,54	ERDS2FJ183	1/4W 18K	2	
R555	ERDS2FJ223	1/4W 22K	1	

Ref.No.	Part No.	Part Name & Description	Pcs	Remarks
R556	ERDS2FJ104	1/4W 100K	1	
R557	ERDS2FJ103	1/4W 10K	1	
R558	ERDS2FJ102	1/4W 1K	1	
R559	ERDS2FJ472	1/4W 4.7K	1	
R561	ERDS2FJ104	1/4W 100K	1	
R563,64	ERDS2FJ272	1/4W 2.7K	2	
R570	ERDS2FJ225	1/4W 2.2M	1	
R571	ERDS2FJ562	1/4W 5.6K	1	
R572	ERDS2FJ153	1/4W 15K	1	
R591	ERDS2FJ472	1/4W 4.7K	1	
R597,98	ERDS2FJ102	1/4W 4.7K	2	
R601-06	ERDS2FJ472	1/4W 4.7K	6	
R607-12	ERDS2FJ563	1/4W 56K	6	
R613	ERDS2FJ103	1/4W 10K	1	
R614,15	ERDS2FJ472	1/4W 4.7K	2	
R616	ERDS2FJ563	1/4W 56K	1	
R617,18	ERDS2FJ472	1/4W 4.7K	2	
R619,20	ERDS2FJ124	1/4W 120K	2	
R621	ERDS2FJ154	1/4W 150K	1	
R622,23	ERDS2FJ124	1/4W 120K	2	
R624	ERDS2FJ154	1/4W 150K	1	
△ R625,26	ERDS1FJ272	1/2W 2.7K	2	
R627	ERDS2FJ474	1/4W 470K	1	
R628	ERDS2FJ223	1/4W 22K	1	
△ R629	ERDS1FJ561	1/2W 560	1	
R637	ERDS2FJ153	1/4W 15K	1	
R638	ERDS2FJ683	1/4W 68K	1	
△ R639-46	ERDS1FJ100	1/2W 10	8	
△ R647,48	ERDS2FJ2H2	1/4W 2.2	2	
△ R649-52	ERDS1FJ100	1/2W 10	4	
R653	EROS2TKF5362	1/4W 53.6K	1	
R654	ERDS2FJ272	1/4W 2.7K	1	
R655	EROS2TKG5622	1/4W 56.2K	1	
R656	ERDS2FJ331	1/4W 330	1	
R661	ERDS2FJ272	1/4W 2.7K	1	
R703-05	ERG1SJ222	1W 2.2K	3	
△ R707	ERDS2FJ4R7	1/4W 4.7	1	
R708	ERDS2FJ472	1/4W 4.7K	1	
R712	ERDS2FJ222	1/4W 2.2K	1	
R719	ERDS2FJ332	1/4W 3.3K	1	
R720	ERDS2FJ272	1/4W 2.7K	1	
△ R721	ERD2FCJ4R7	1/4W 4.7	1	
△ R722	ERQ16NKW2R2E	1/6W 2.2	1	
R723	ERDS2FJ562	1/4W 5.6K	1	
R724	ERDS2FJ392	1/4W 3.9K	1	
R725	ERDS2FJ100	1/4W 10	1	
R727	ERDS2FJ392	1/4W 3.9K	1	
R729	ERDS2FJ221	1/4W 220	1	
R738	ERDS2FJ392	1/4W 3.9K	1	
R739	ERDS2FJ473	1/4W 47K	1	
R749	ERDS2FJ102	1/4W 1K	1	
R753	ERD16TJ000T	1/6W 0	1	
R763	ERDS2FJ472	1/4W 4.7K	1	
R764	ERDS2FJ331	1/4W 330	1	
R765	ERDS1FJ221	1/2W 220	1	
△ R766	ERDS1FJ470	1/2W 47	1	
△ R767	ERDS2FJ4R7	1/4W 4.7	1	
R768	ERDS2FJ101	1/4W 100	1	
R771	ERDS2FJ222	1/4W 2.2K	1	
R772	ERDS2FJ223	1/4W 22K	1	
△ R773	ERDS1FJ470	1/2W 47	1	
△ R774	ERDS1FJ270	1/2W 27	1	
R776	ERDS2FJ103	1/4W 10K	1	
R777	ERDS2FJ102	1/4W 1K	1	
△ R779	ERDS1FJ470	1/2W 47	1	
△ R791,92	RSFMB30KT-L	FUSE PROTECTOR	2	
R793	ERDS2FJ1R0	1/4W 1	1	
R794	ERDS2FJ473	1/4W 47K	1	
R795	ERDS2FJ392	1/4W 3.9K	1	
R901	ERDS2FJ821	1/4W 820	1	
R902	ERDS2FJ102	1/4W 1K	1	
R903	ERDS2FJ122	1/4W 1.2K	1	
R904	ERDS2FJ152	1/4W 1.5K	1	
R905	ERDS2FJ182	1/4W 1.8K	1	
R906	ERDS2FJ222	1/4W 2.2K	1	
R907	ERDS2FJ332	1/4W 3.3K	1	
R908	ERDS2FJ472	1/4W 4.7K	1	
R909	ERDS2FJ182	1/4W 1.8K	1	

■ Cabinet Parts Location

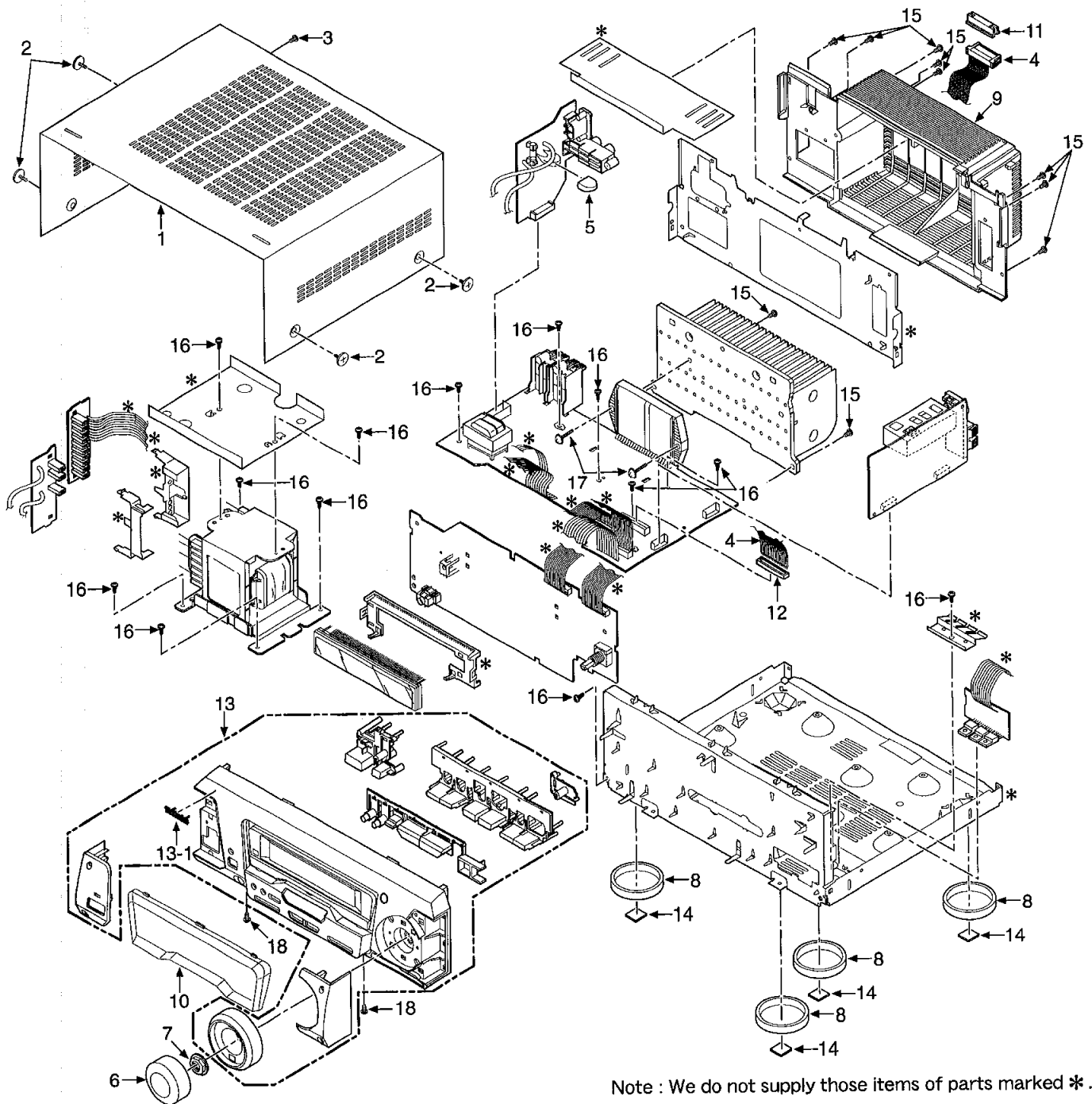

Ref.No.	Part No.	Part Name & Description	Pcs	Remarks
1	RKM0395-S	CABINET	1	
2	RHD30007-K1	SCREW	4	
3	XTBS3+10JFZ1	SCREW	1	
4	REX0967	WIRE ASS'Y	1	
5	RMZ0339	ZNR COVER	1	
6	RGW0317-S1	KNOB,VOLUME	1	
7	RHN90001	NUT	1	
8	RKA0106-N	FOOT RING	4	
9	RKF0589-K	BACK GRILL	1	
10	RKW0581-V	FL WINDOW	1	

Ref.No.	Part No.	Part Name & Description	Pcs	Remarks
11	RMN0427	CABLE HOLDER	1	
12	RLBT4001-N	FERRITE CORE	1	
13	RYP0915-S	FRONT PANEL	1	
13-1	RGB0025-A	TECHNICS BADGE	1	
14	SHG1654	RUBBER	4	
15	XTB3+10JFZ	SCREW	10	
16	XTB3+8JFZ	SCREW	13	
17	XTW3+15T	SCREW	2	
18	XTBS3+8JFZ1	SCREW	2	

