

**Remote
Control
Transmitter**

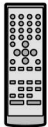

***SB-PS75**

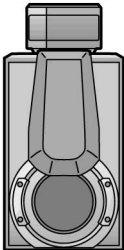

***SB-EH760**

***SB-PC75**

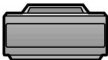

SL-EH760

SH-EH760

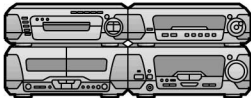

RS-EH760

SA-EH760

***SB-PS75**

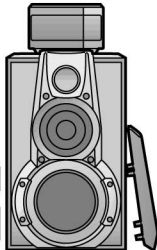

***SB-EH760**

(For United Kingdom)

("EB" area code model only)

For your safety, please read the following text carefully.

This appliance is supplied with a moulded three pin mains plug for your safety and convenience.

A 5-ampere fuse is fitted in this plug.

Should the fuse need to be replaced please ensure that the replacement fuse has a rating of 5-ampere and that it is approved by ASTA or BSI to BS1362.

Check for the ASTA mark  or the BSI mark  on the body of the fuse.

If the plug contains a removable fuse cover you must ensure that it is refitted when the fuse is replaced.

If you lose the fuse cover the plug must not be used until a replacement cover is obtained.

A replacement fuse cover can be purchased from your local dealer.

CAUTION!

IF THE FITTED MOULDED PLUG IS UNSUITABLE FOR THE SOCKET OUTLET IN YOUR HOME THEN THE FUSE SHOULD BE REMOVED AND THE PLUG CUT OFF AND DISPOSED OF SAFELY. THERE IS A DANGER OF SEVERE ELECTRICAL SHOCK IF THE CUT OFF PLUG IS INSERTED INTO ANY 13-AMPERE SOCKET.

If a new plug is to be fitted please observe the wiring code as shown below.

If in any doubt please consult a qualified electrician.

IMPORTANT

The wires in this mains lead are coloured in accordance with the following code:

Blue: Neutral, Brown: Live.

As these colours may not correspond with the coloured markings identifying the terminals in your plug, proceed as follows:

The wire which is coloured Blue must be connected to the terminal which is marked with the letter N or coloured Black or Blue.

The wire which is coloured Brown must be connected to the terminal which is marked with the letter L or coloured Brown or Red.

WARNING: DO NOT CONNECT EITHER WIRE TO THE EARTH TERMINAL WHICH IS MARKED WITH THE LETTER E, BY THE EARTH SYMBOL  OR COLOURED GREEN OR GREEN/YELLOW.

THIS PLUG IS NOT WATERPROOF—KEEP DRY.

Before use

Remove the connector cover.

How to replace the fuse

The location of the fuse differ according to the type of AC mains plug (figures A and B). Confirm the AC mains plug fitted and follow the instructions below.

Illustrations may differ from actual AC mains plug.

1. Open the fuse cover with a screwdriver.

Figure A

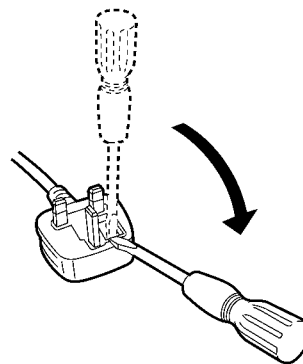
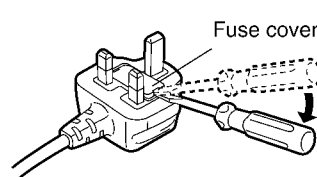

Figure B



2. Replace the fuse and close or attach the fuse cover.

Figure A

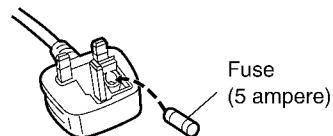
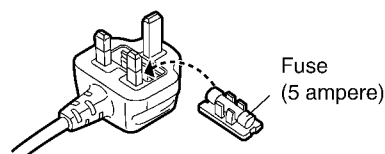
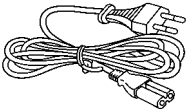
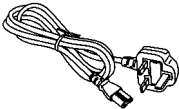
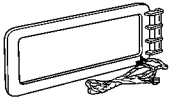

Figure B

















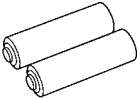



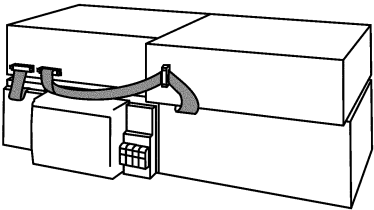

or

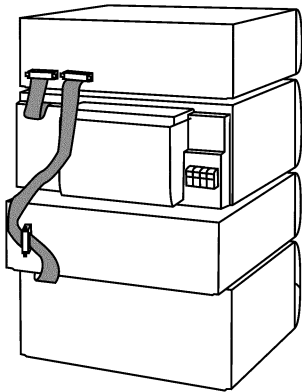

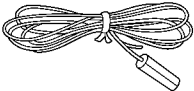









(Step 3)

Remove the top cabinet.

(Step 2)

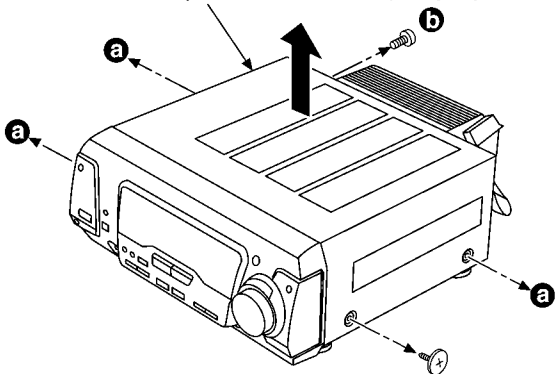

a × 4
(Step 1)

AC IN P.C.B.

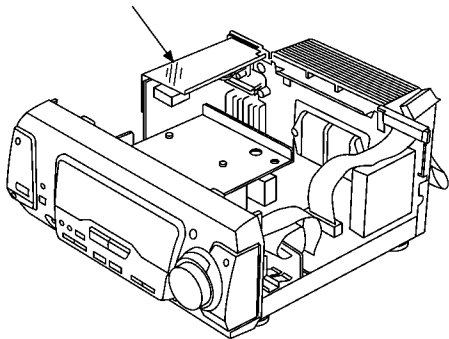

(Step 3)

Release the 6 claws.

Claws

(Step 4)

Pull out the front panel ass'y.

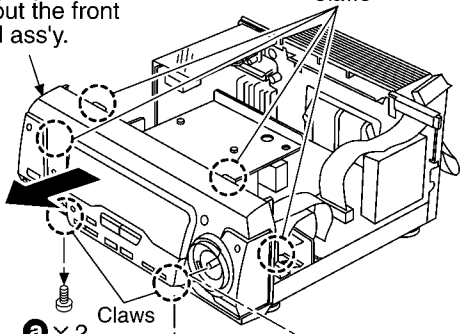

a × 2
(Step 2)

Claws

a

Nut

Volume knob

(Step 1)

Remove the volume knob and nut.

(Step 6)

Release the 3 claws, and then remove the operation P.C.B..

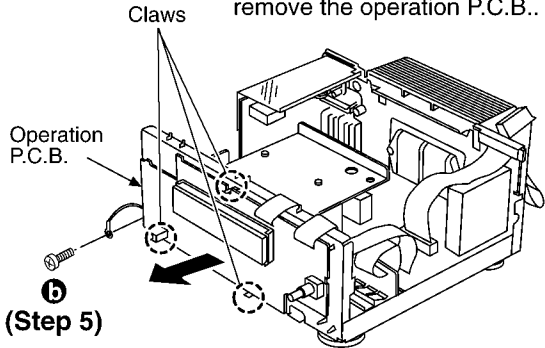

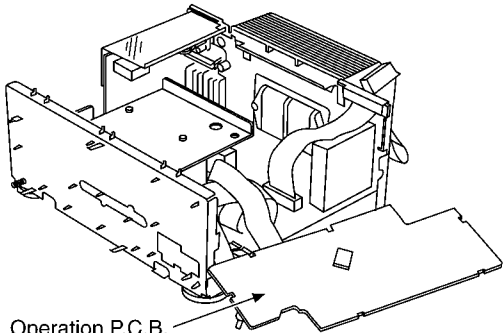

Operation P.C.B.

(Step 2)

Remove the
cable holder.

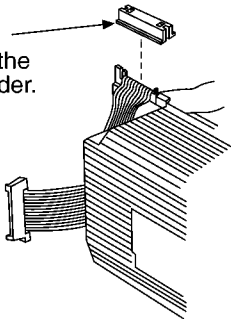

(Step 1)

a × 8

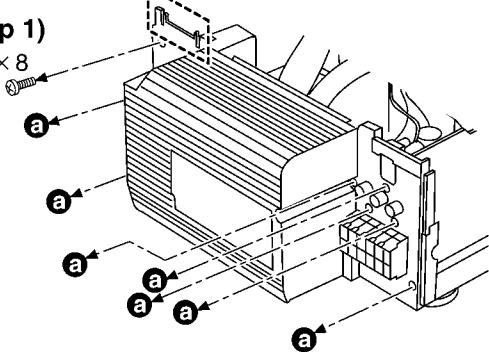

(Step 3)

Release the 2 claws, and then
remove the rear grille ass'y.

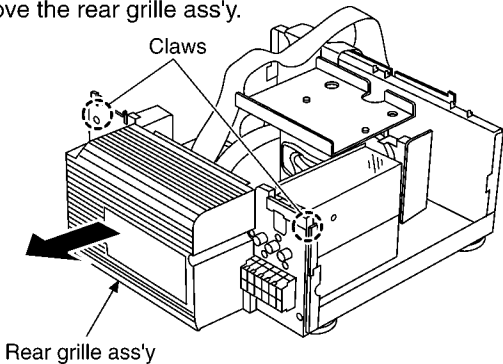

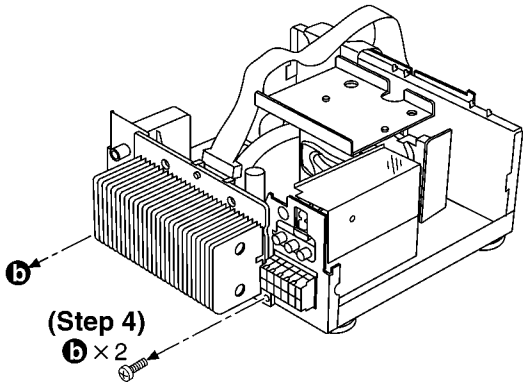

(Step 5)

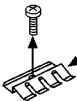

(Step 6)

Remove the transistor holder.

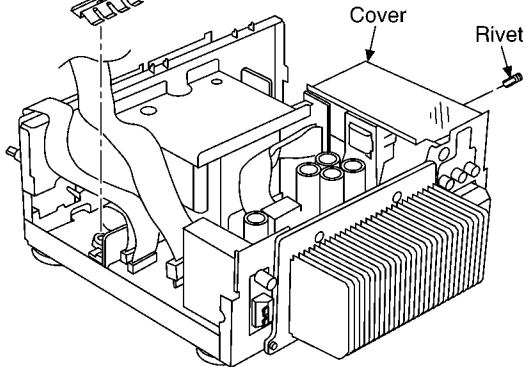

(Step 7)

Remove the rivet, and then remove the cover.

(Step 8)

d × 5



d

d

d

(Step 9)



c

d

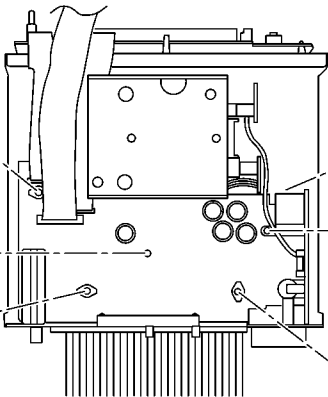

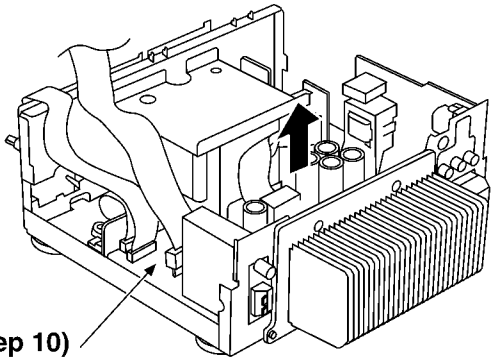

(Step 10)

Lift up the main P.C.B..

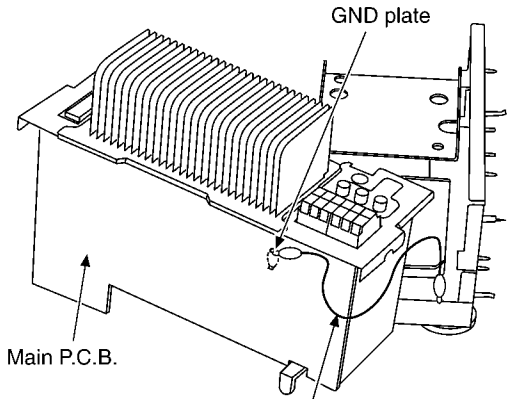

(Step 11)
Connect the lead wire.

(Step 1)

a

(Step 2)

Remove the transistor holder.

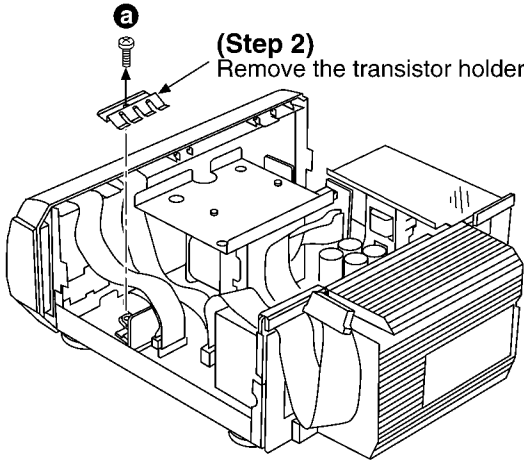

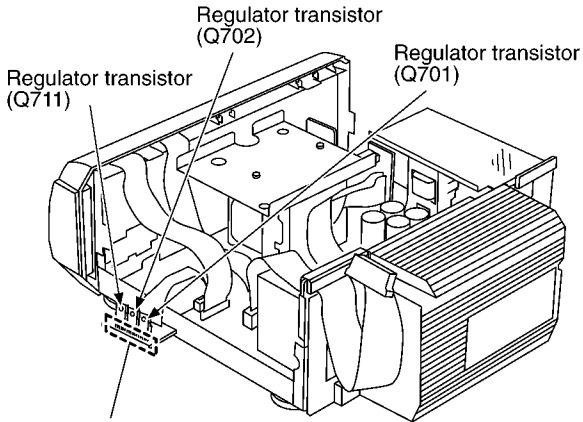

(Step 3)

Unsolder the terminals of regulator transistors.

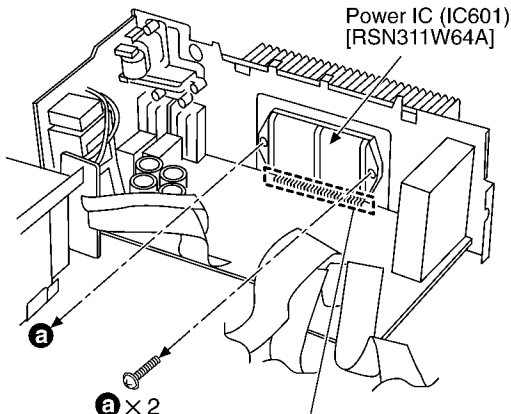

(Step 1)

(Step 2)

Unsolder the terminals
of power IC.

NOTE:

When mounting the power IC apply
silicone compound (RFKX0002) to the
rear side of power IC.

A

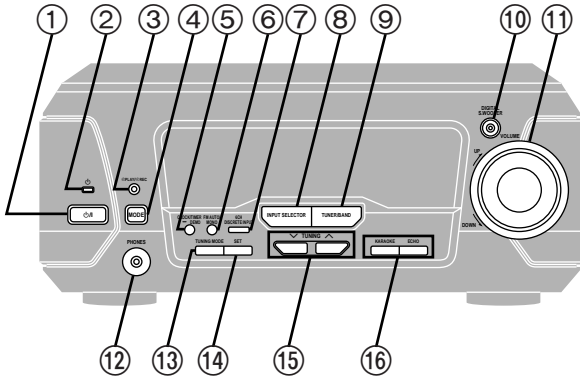

A Tuner amplifier

- ① **Standby/on switch (⏻/⏻)**
Press to switch the unit from on to standby mode or vice versa. In standby mode, the unit is still consuming a small amount of power.
- ② **Standby indicator (⏻)**
When the unit is connected to the AC mains supply, this indicator lights up in standby mode and goes out when the unit is turned on.
- ③ **Play timer/record timer button and indicator (⏻PLAY/⏻REC)**
- ④ **ECO mode button (MODE)**
- ⑤ **Clock/timer, demo button (CLOCK/TIMER, -DEMO)**
- ⑥ **FM mode button (FM AUTO/MONO)**
- ⑦ **6ch discrete input button (6CH DISCRETE INPUT)**
- ⑧ **Source input button (INPUT SELECTOR)**
- ⑨ **Tuner/band button (TUNER/BAND)**
- ⑩ **Digital super woofer button and indicator (DIGITAL S.WOOFER)**
- ⑪ **Volume control (VOLUME)**
- ⑫ **Headphone jack (PHONES)**
- ⑬ **Tuning mode button (TUNING MODE)**
- ⑭ **Set button (SET)**
- ⑮ **Tuning buttons (v, ^ TUNING)**
- ⑯ **RDS display mode buttons (RDS, PS-DISP MODE-PTY)**

B

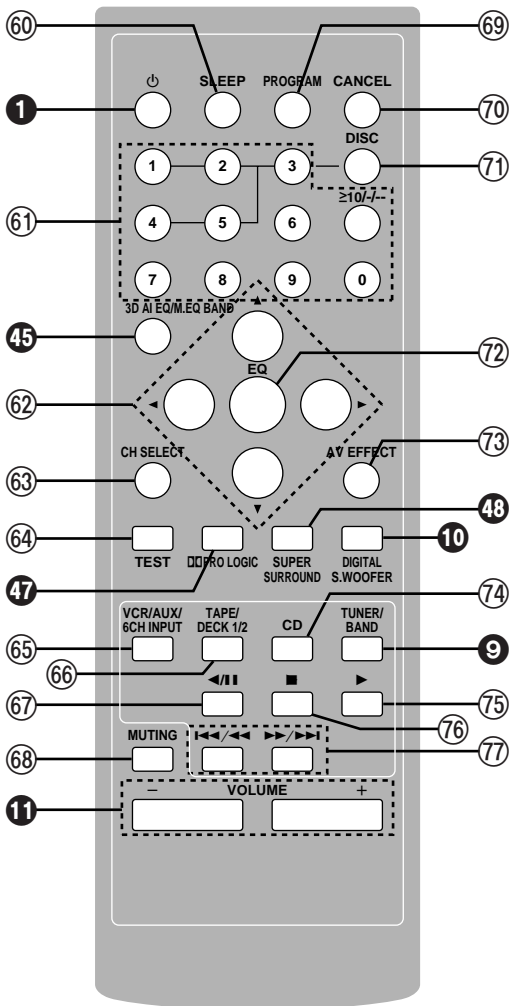

B Remote controls

- Buttons ①, ⑨-⑪, ④⑤, ④⑦ and ④⑧ function in the same way as the controls on the main unit.
- ⑥① **Sleep timer button (SLEEP)**
 - ⑥② **Numbered buttons (1-9, 0, ≥10/-/-)**
 - ⑥③ **Cursor buttons (◀, ▶, ▲, ▼)**
 - ⑥④ **Channel select button (CH SELECT)**
 - ⑥⑤ **Test button (TEST)**
 - ⑥⑥ **Input select button (VCR/AUX/6CH INPUT)**
 - ⑥⑦ **TAPE select, deck 1/deck 2 select button (TAPE/DECK 1/2)**
 - ⑥⑧ **CD pause/Tape reverse playback button (◀/II)**
 - ⑥⑨ **Muting button (MUTING)**
 - ⑦① **Program button (PROGRAM)**
 - ⑦② **Cancel button (CANCEL)**
 - ⑦③ **Disc button (DISC)**
 - ⑦④ **EQ button (EQ)**
 - ⑦⑤ **AV effect button (AV EFFECT)**
 - ⑦⑥ **CD button (CD)**
 - ⑦⑦ **CD play/tape forward playback button (▶)**
 - ⑦⑧ **CD/tape stop button (■)**
 - ⑦⑨ **CD skip/search, tape fast forward/rewind buttons (I◀◀/◀, ▶/▶▶I)**

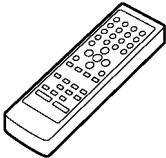

Z120 TUNER UNIT (RAN0005EM)

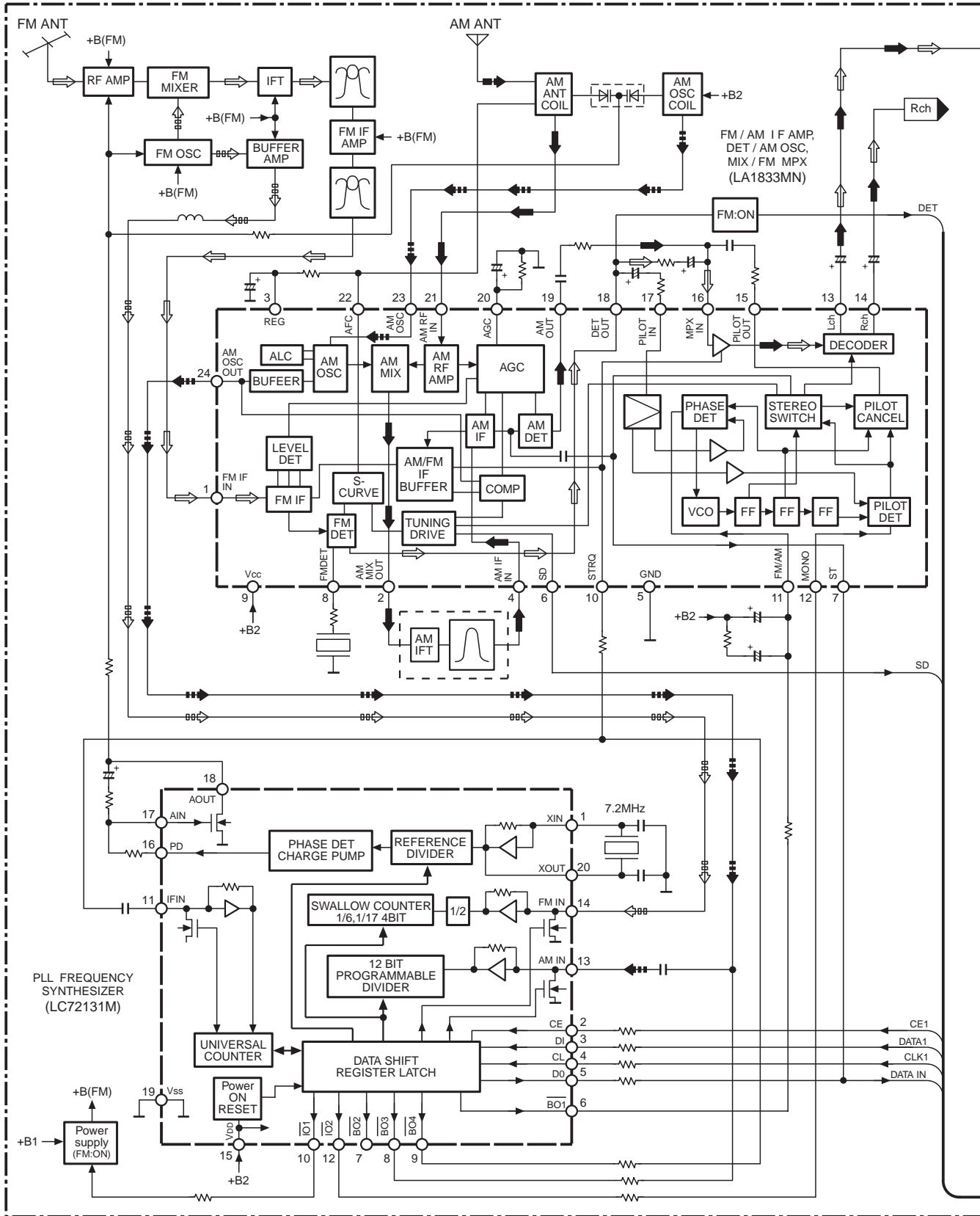

To SOUND PROCESSOR
BLOCK DIAGRAM

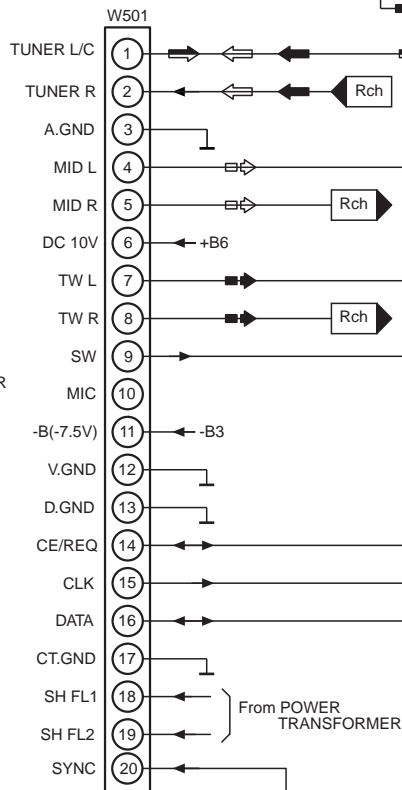

BU4053BCFE2
IC201
SIGNAL SELECTOR

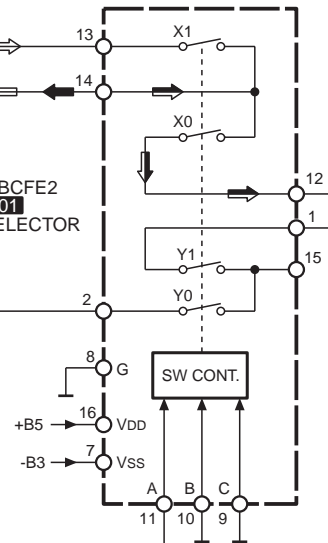

SW CONT.

LC8A524A5N28
IC901

SYSTEM CONTROL / FL DRIVE

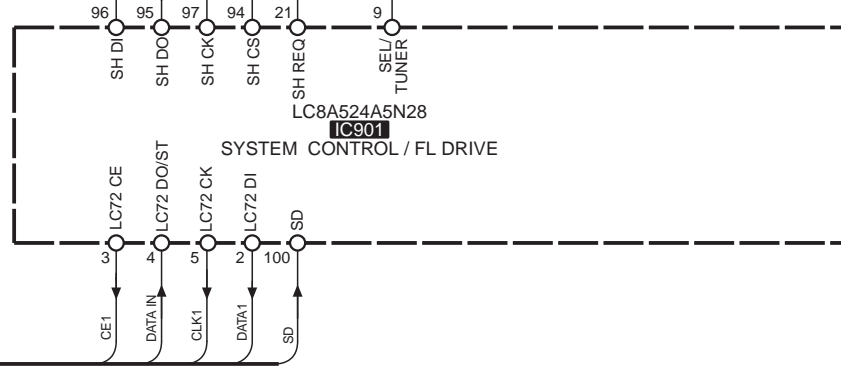

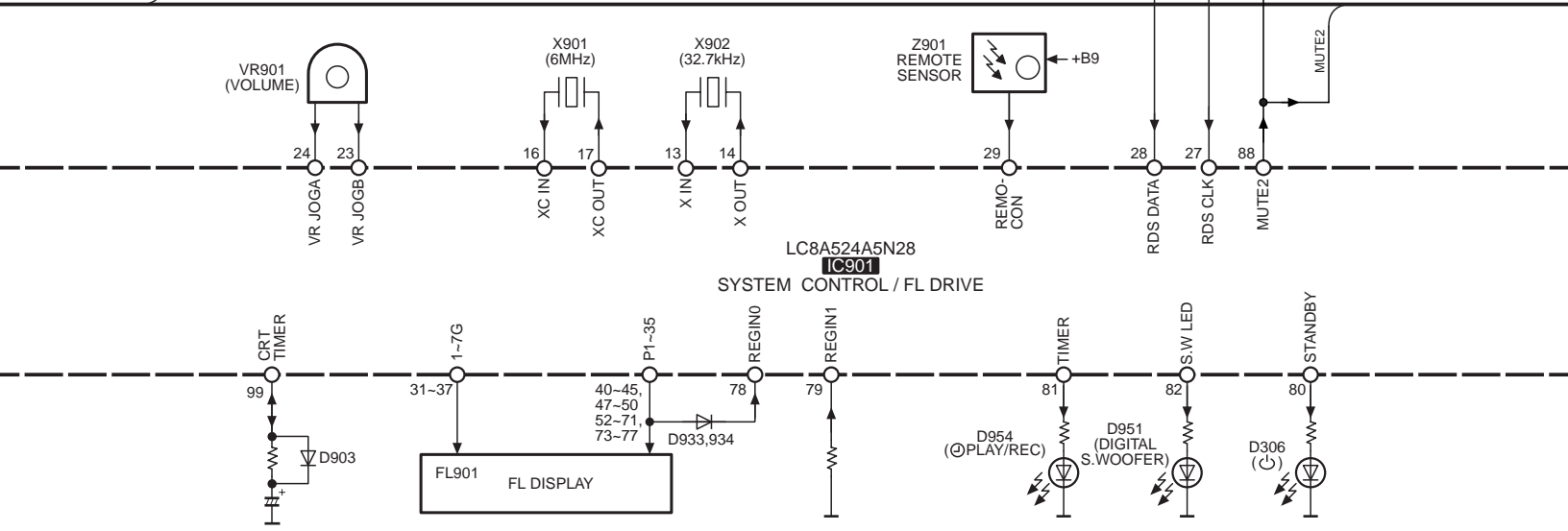
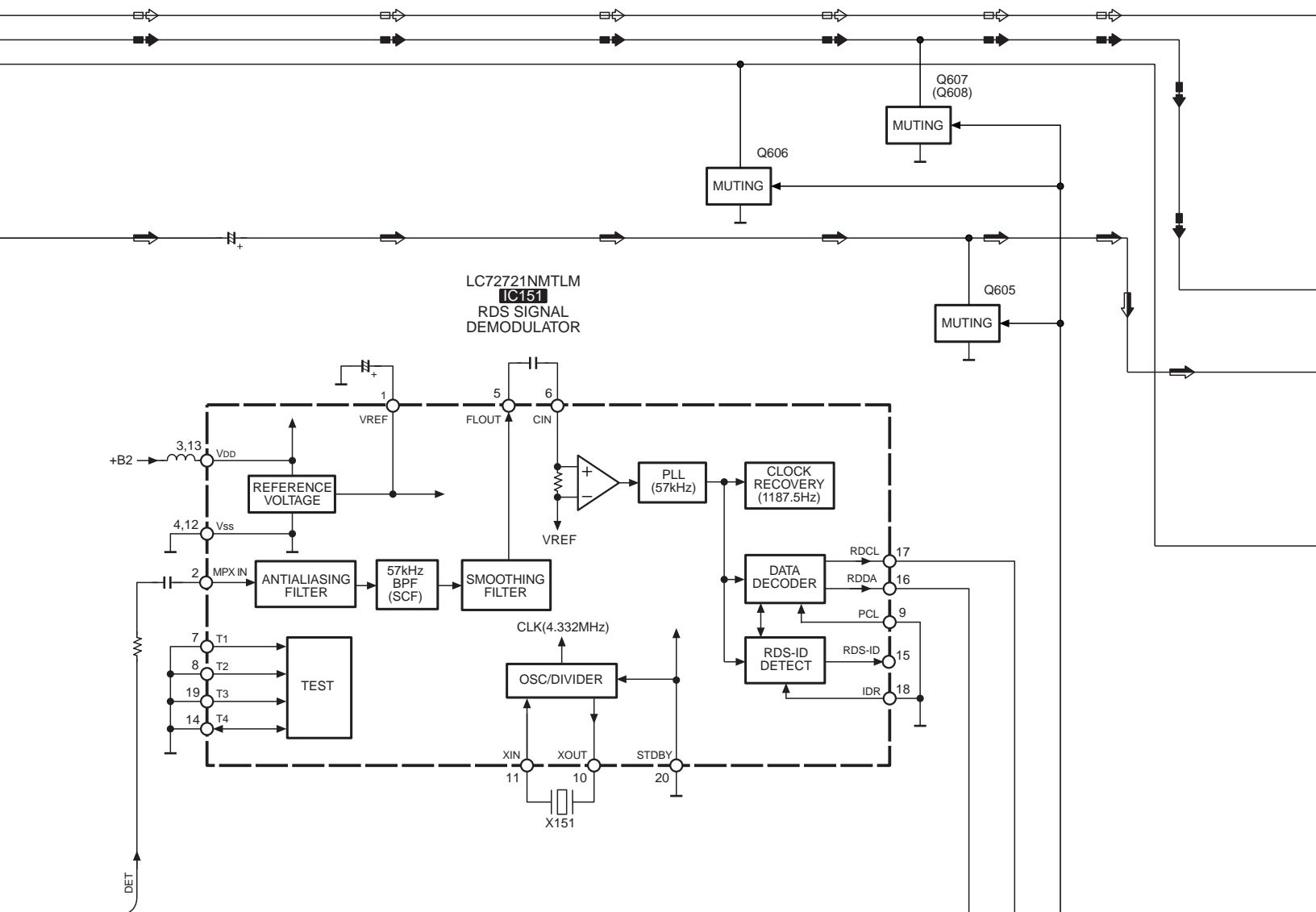

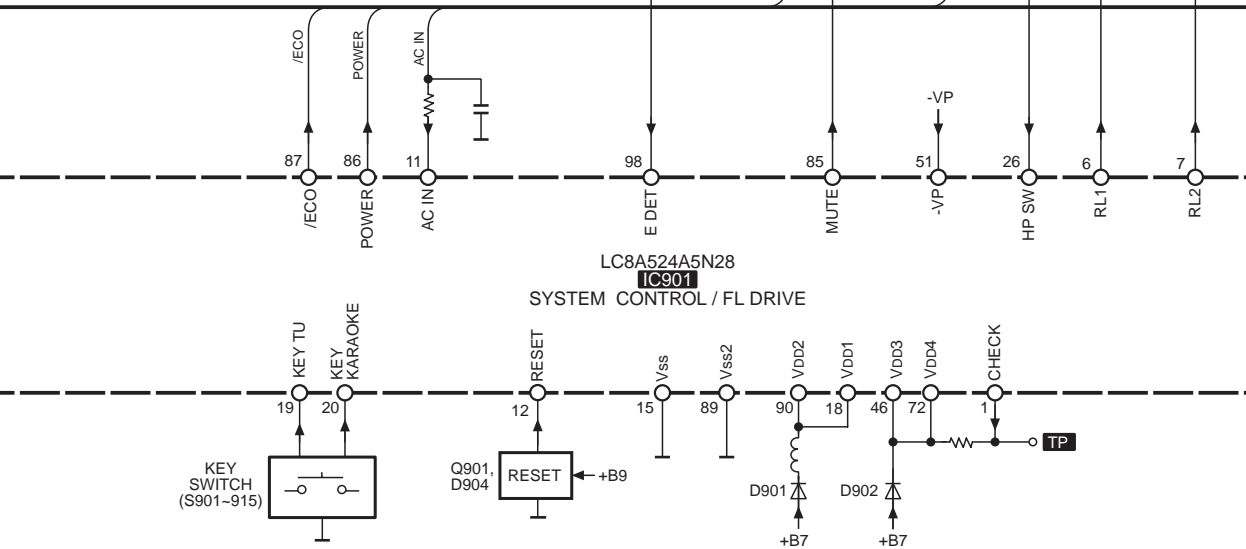
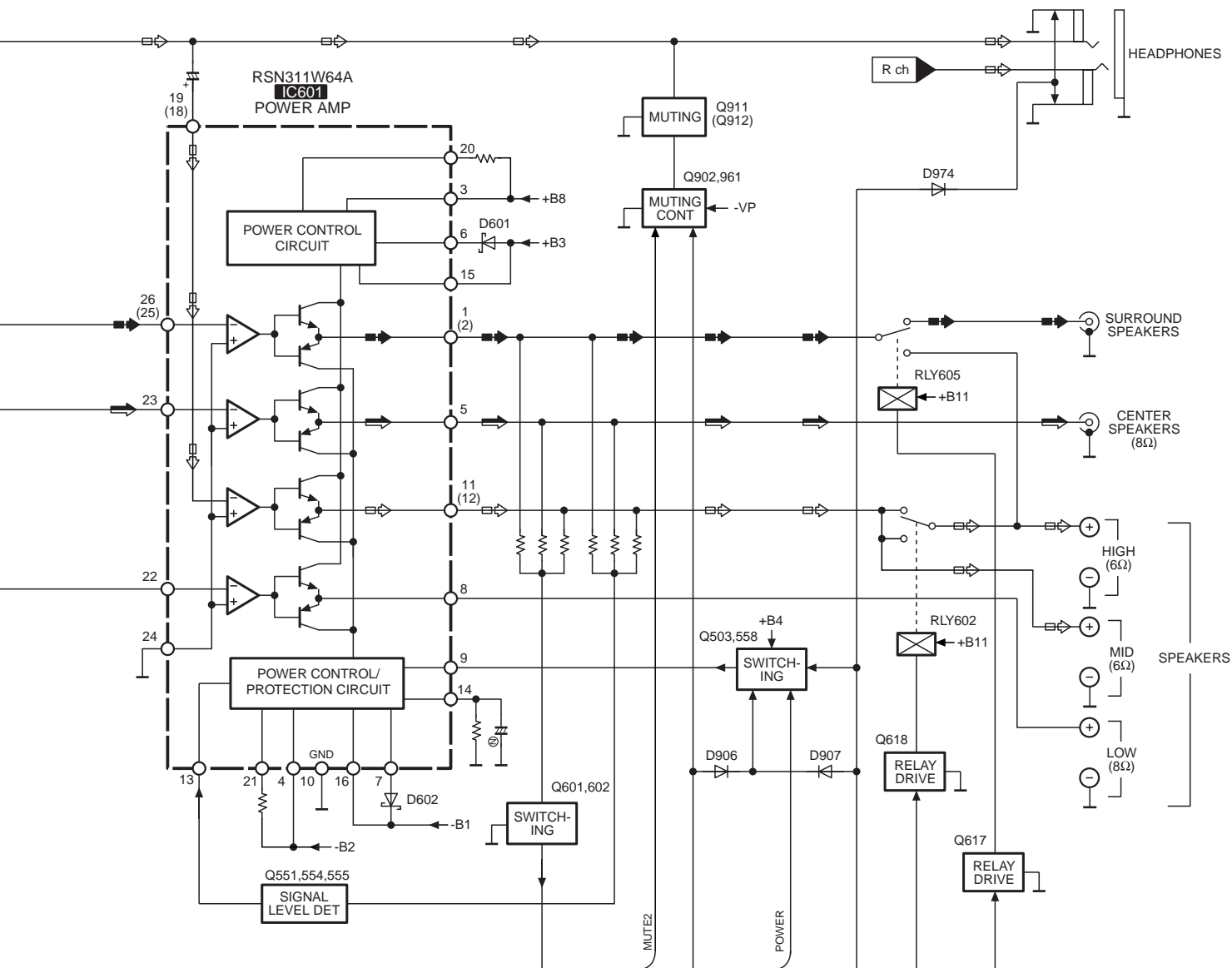

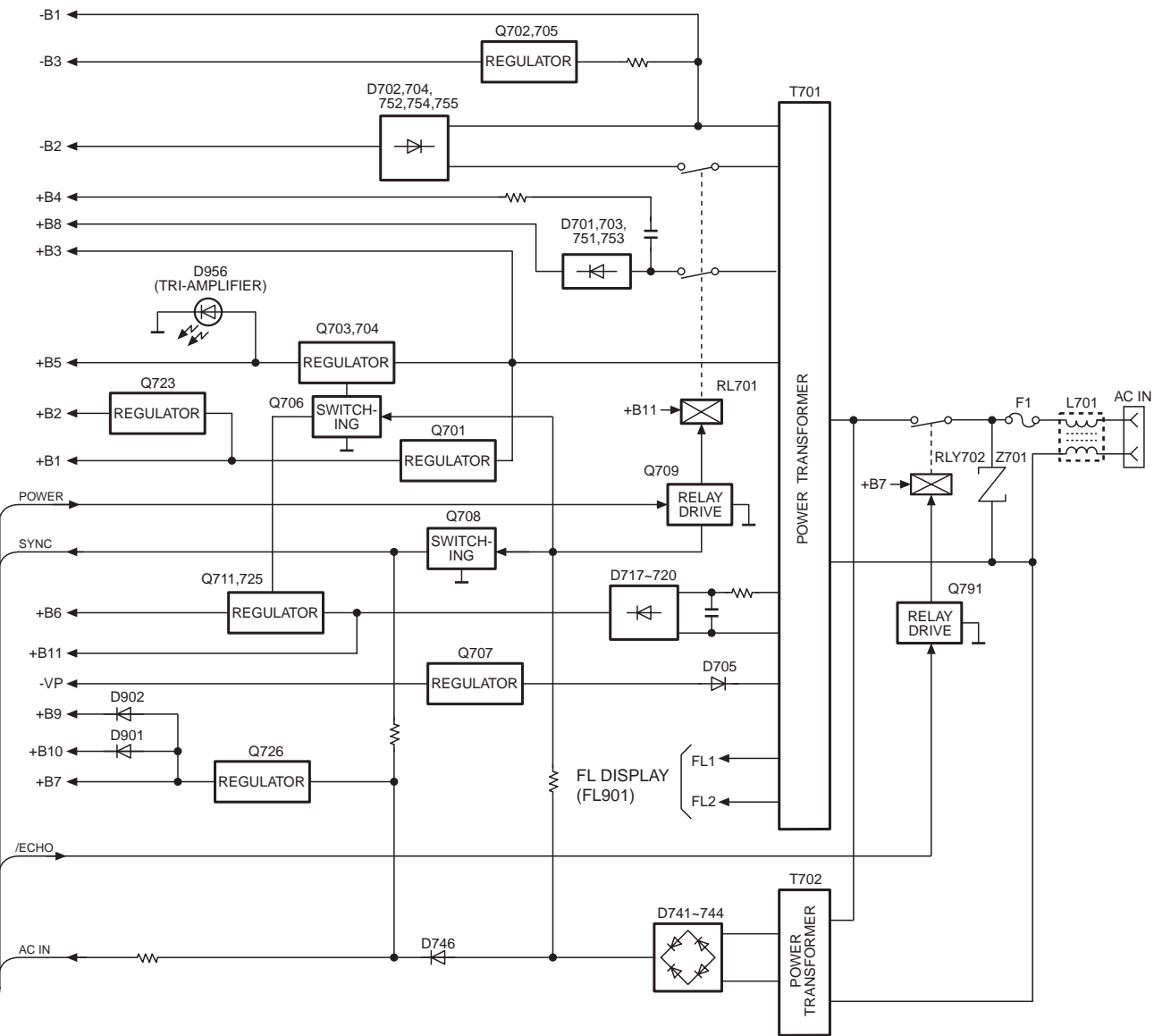

NOTES :

- SIGNAL LINE
- ⇨ FM SIGNAL
- ⇨ AM SIGNAL
- ⇨ FM OSC SIGNAL
- ⇨ AM OSC SIGNAL
- ⇨ SOURCE SIGNAL
- ⇨ CENTER SP. DRIVE SIGNAL
- ⇨ SURROUND SP. DRIVE SIGNAL
- () indicates pin No. Right channel.

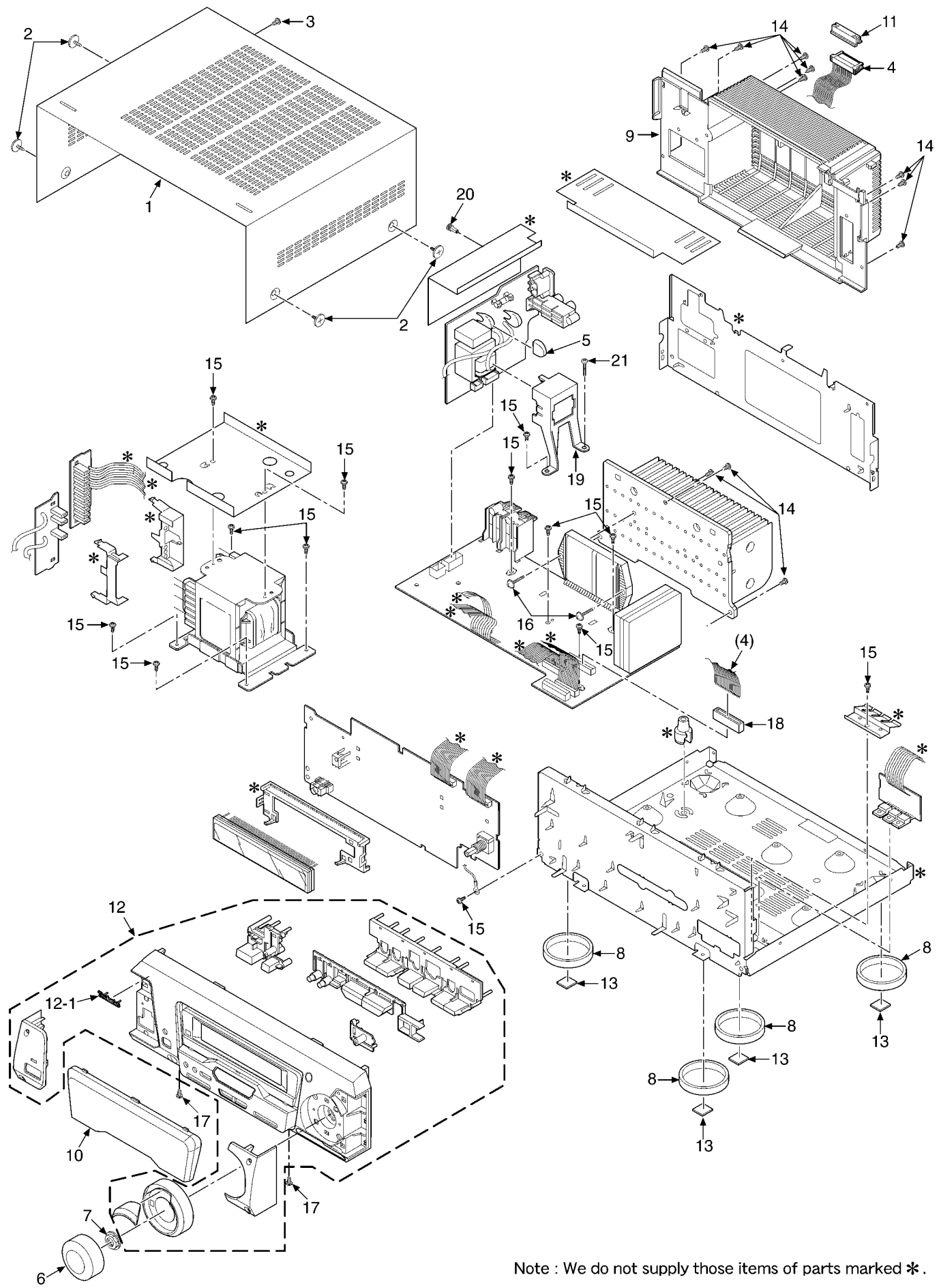

Note : We do not supply those items of parts marked * .

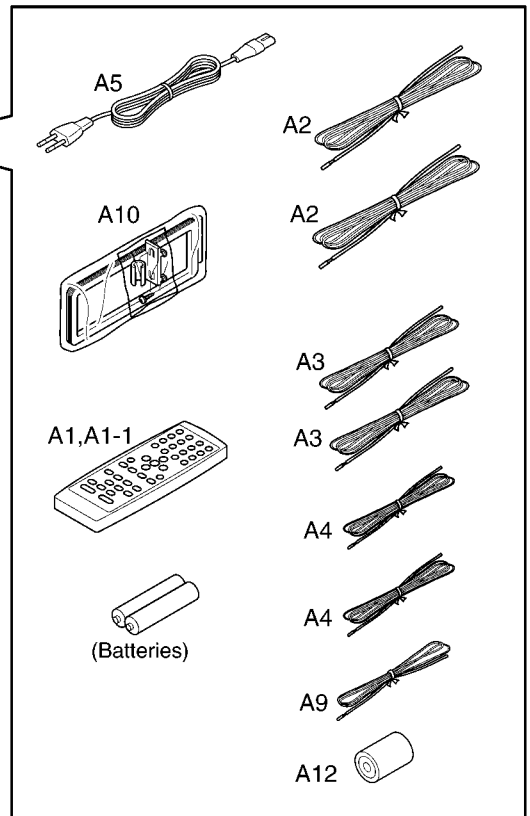
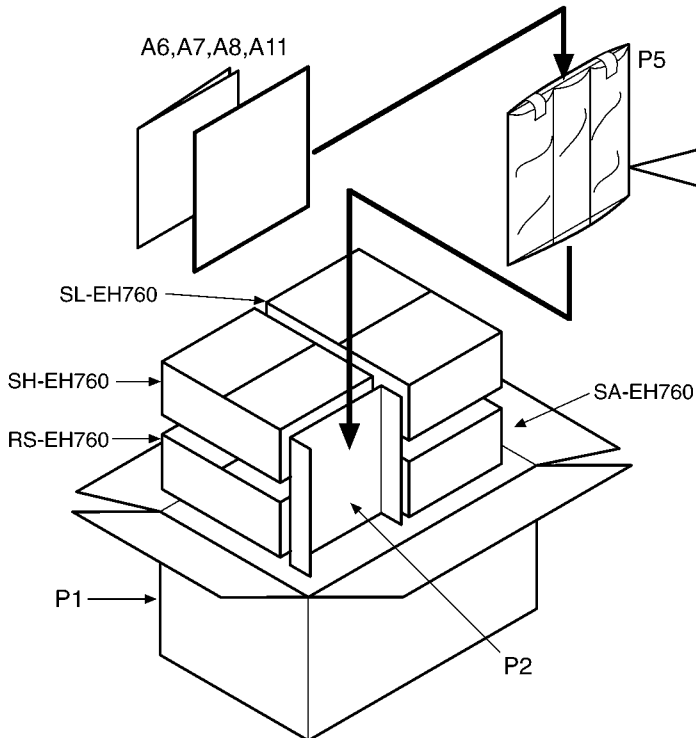
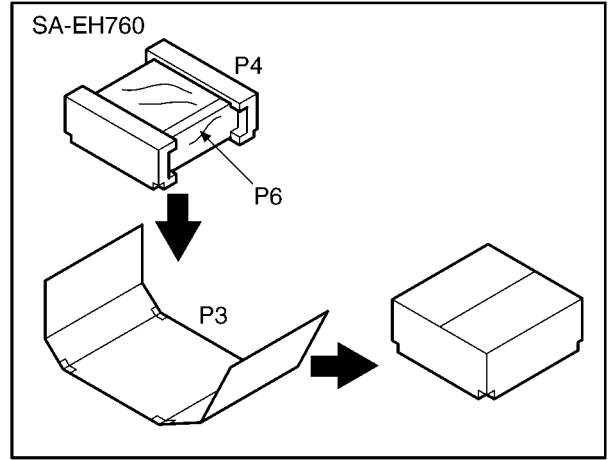
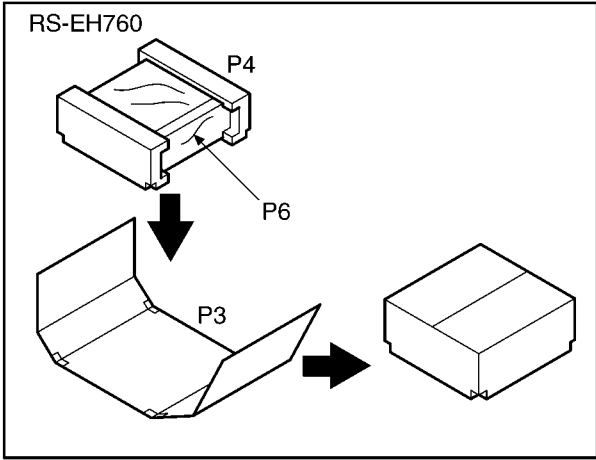
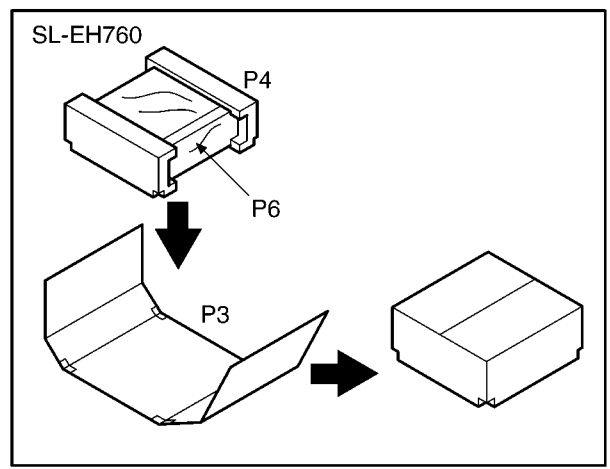
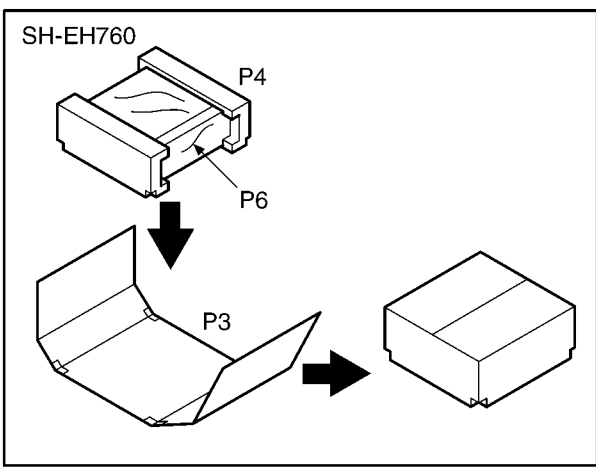

B MAIN P.C.B.

1
2
3
4
5
6
7
8

To SOUND PROCESSOR

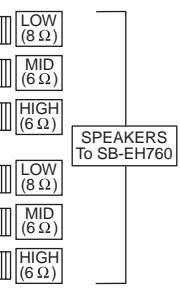
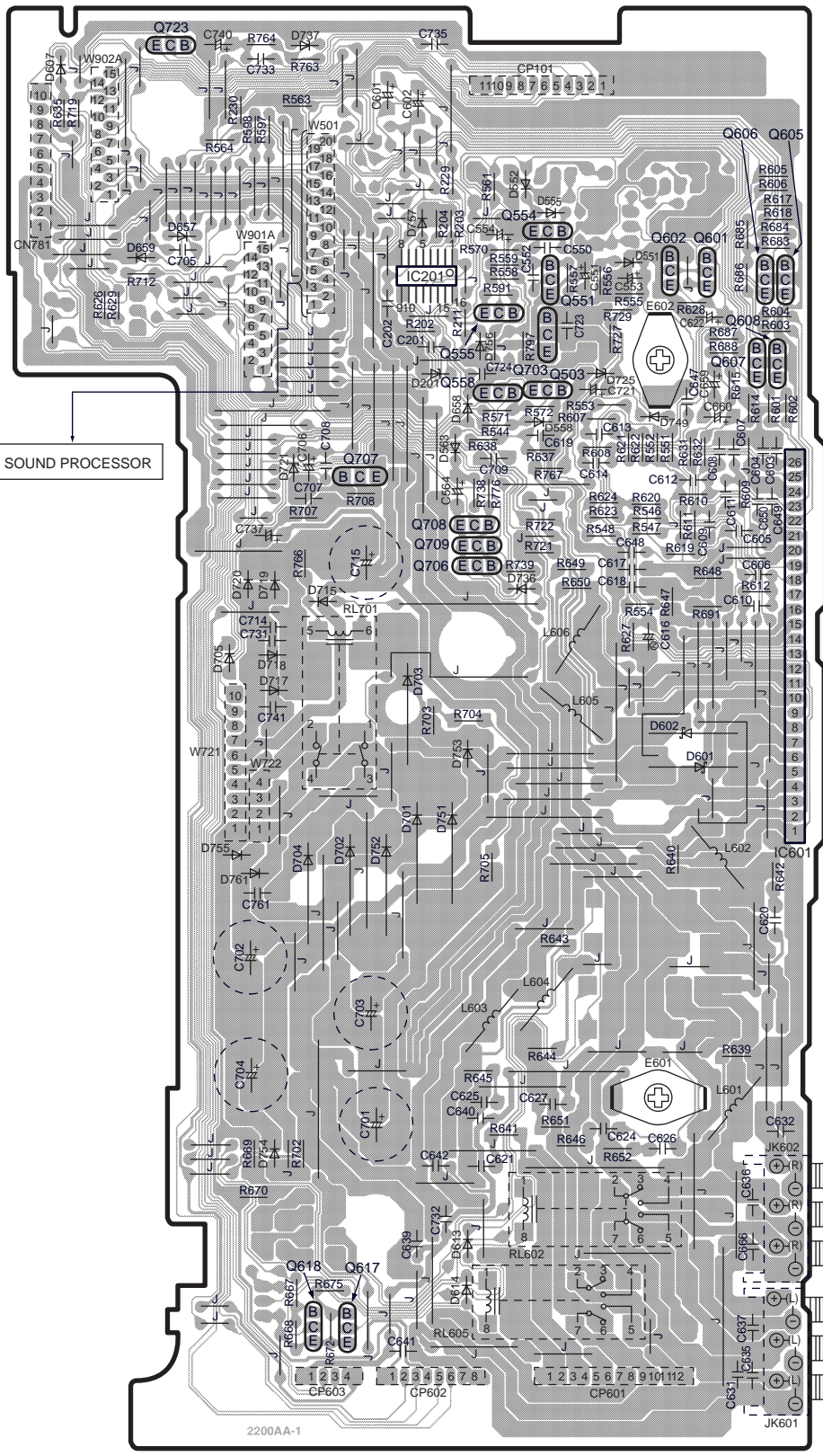

A B C D E F

D AC IN P.C.B.

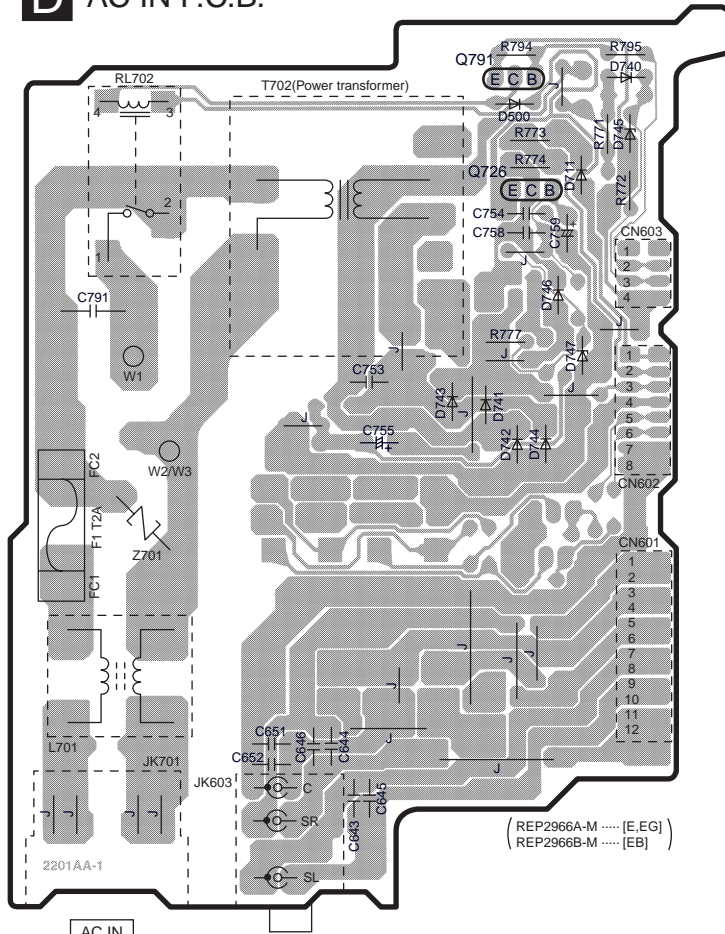

(230V 50Hz [E,EG])
 (230-240V 50Hz [EB])

ELECTRICAL PARTS LOCATION

Ref. No.	Lo. No.	Ref. No.	Lo. No.
D SPEAKER TERMINAL P.C.B.			
Q726	2D	FC2	3A
Q791	1C	W1	2B
D500	1C	W2/W3	3B
D711	2D	R771	1D
D740	1D	R772	2D
D741	3C	R773	1D
D742	3D	R774	2D
D743	3C	R777	2C
D744	3D	R794	1C
D745	1D	R795	1D
D746	2D	C643	4C
D747	2D	C644	4C
L701	4B	C645	4C
T702	2C	C646	4C
Z701	3B	C651	4B
F1	3A	C652	4B
RL702	2B	C753	3C
CN601	4D	C754	2D
CN602	3D	C755	3C
CN603	2D	C758	2D
JK603	5B	C759	2D
JK701	5B	C791	2B
FC1	3A		
E POWER TRANSFORMER(A) P.C.B.			
CN701	6B	CN709	8B
CN702	6B	CN710	8B
CN703	7B	W21	7A
CN704	7B	W22	7A
CN705	7B	R791	8A
CN706	7B	R792	8A
CN707	7B	R793	6A
CN708	8B		
F POWER TRANSFORMER(B) P.C.B.			
CN711	6D	W1	6E
CN712	7D	W2	7E
CN713	7D	W3	7E

E POWER TRANSFORMER (A) P.C.B.

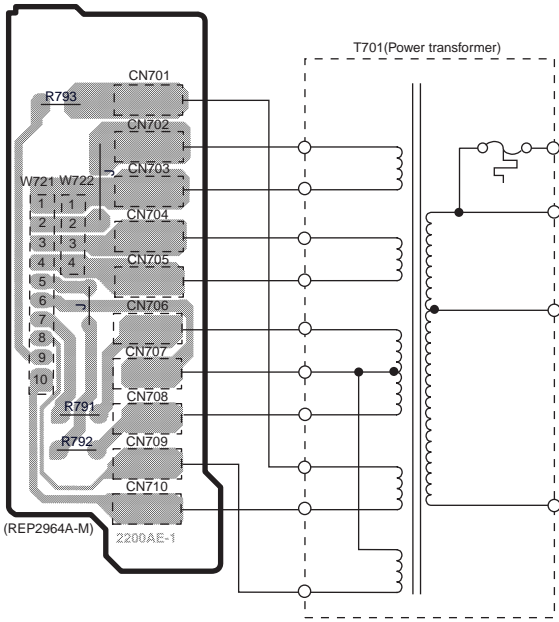

F POWER TRANSFORMER (B) P.C.B.

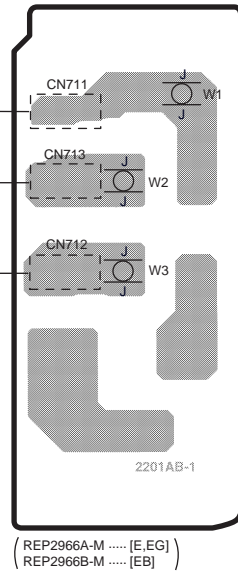

(REP2966A-M [E,EG])
 (REP2966B-M [EB])

1
2
3
4
5
6
7
8

A B C D E F

A OPERATION P.C.B.

1
2
3
4
5
6
7
8

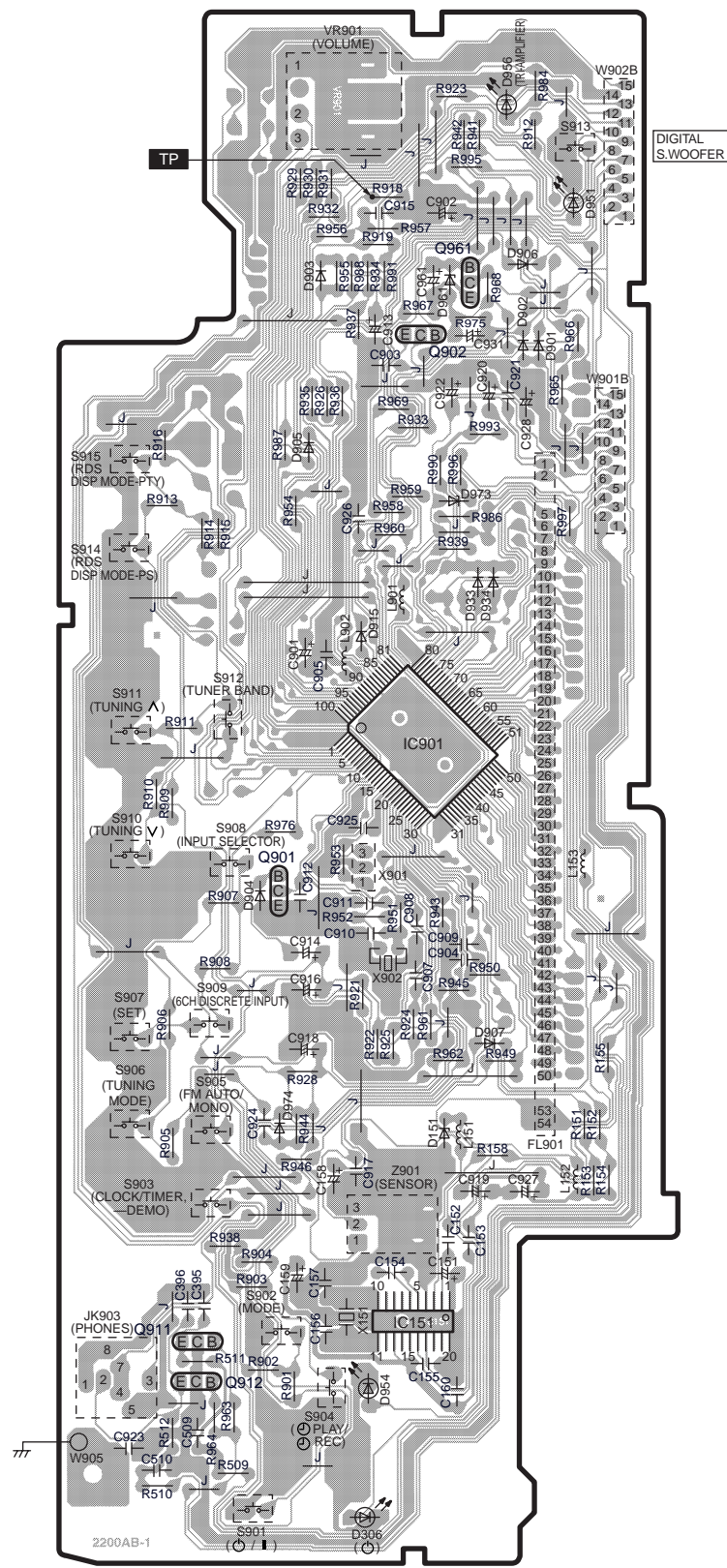

ELECTRICAL PARTS LOCATION

Ref. No.	Lo. No.	Ref. No.	Lo. No.	Ref. No.	Lo. No.
A OPERATION P.C.B.					
IC151	7C	R510	8A	R966	3C
IC901	4C	R511	7B	R967	2C
Q901	5B	R512	8A	R968	2C
Q902	3C	R901	7B	R969	3C
Q911	7B	R902	7B	R975	3C
Q912	7B	R903	7B	R976	5B
Q961	2C	R904	7B	R984	1C
D151	6C	R905	6A	R986	3C
D306	8B	R906	6A	R987	3B
D901	3C	R907	5B	R988	2B
D902	3C	R908	6B	R990	3C
D903	2B	R909	5A	R991	2B
D904	5B	R910	5A	R993	3C
D905	3B	R911	4B	R995	2C
D906	2C	R912	2C	R996	3C
D907	6C	R913	3A	R997	3C
D915	4B	R914	4B	C151	7C
D933	4C	R915	4B	C152	7C
D934	4C	R916	3A	C153	7C
D951	2C	R918	2B	C154	7C
D954	7B	R919	2B	C155	7C
D956	1C	R921	6B	C156	7B
D961	2C	R922	6B	C157	7B
D973	3C	R923	1C	C158	7B
D974	6B	R924	6C	C159	7B
VR901	1B	R925	6C	C160	7C
L151	6C	R926	3C	C395	7B
L152	7C	R928	6B	C396	7B
L153	5C	R929	2B	C509	8B
L901	4C	R930	2B	C510	8A
L902	4B	R931	2B	C901	4B
Z901	7C	R932	2B	C902	2C
X151	7B	R933	3C	C903	3B
X901	5B	R934	2B	C904	5C
X902	6B	R935	3B	C905	4B
FL901	6C	R936	3B	C907	6C
S901	8B	R937	3B	C908	5C
S902	7B	R938	7B	C909	5C
S903	7B	R939	4C	C910	5B
S904	8B	R941	2C	C911	5B
S905	6B	R942	2C	C912	5B
S906	6A	R943	5C	C913	3B
S907	6A	R944	6B	C914	5B
S908	5B	R945	6B	C915	2B
S909	6B	R946	6B	C916	6B
S910	5A	R949	6C	C917	6B
S911	4A	R950	6C	C918	6B
S912	4B	R951	5C	C919	7C
S913	2C	R952	5B	C920	3C
S914	4A	R953	5B	C921	3C
S915	3A	R954	3B	C922	3C
JK903	7A	R955	2B	C923	8A
W901B	3D	R956	2B	C924	6B
W902B	2D	R957	2B	C925	5B
W905	8A	R958	3B	C926	3B
R151	6C	R959	3C	C927	7C
R152	6C	R960	4C	C928	3C
R153	7C	R961	6C	C931	3C
R154	7D	R962	6C	C961	2C
R155	6D	R963	8B		
R158	6C	R964	8B		
R509	8B	R965	3C		

B MAIN P.C.B.

1
2
3
4
5
6
7
8

To SOUND PROCESSOR

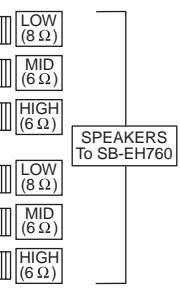
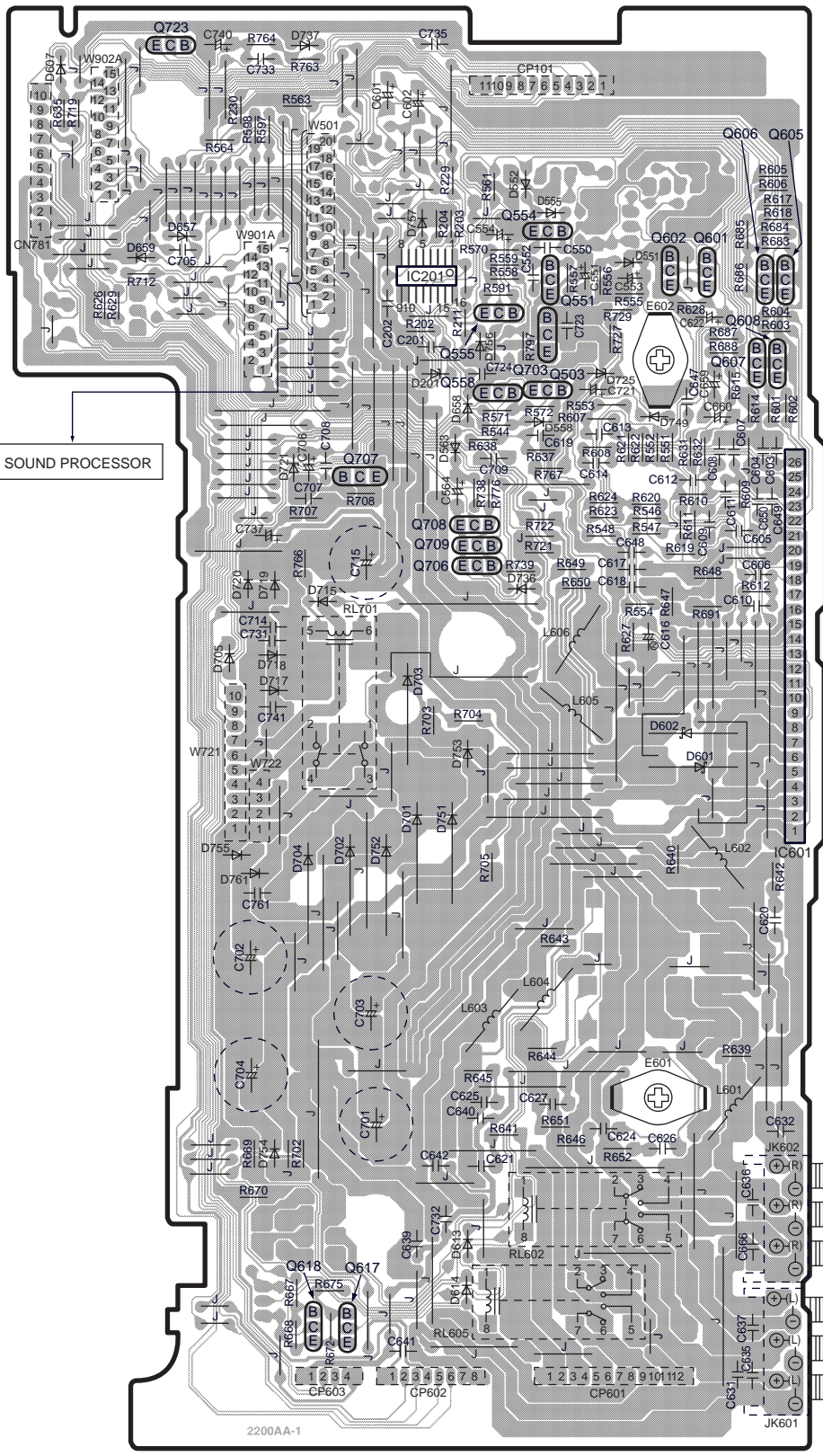

2200AA-1

(REP2964A-M)

G

H

I

J

K

L

C POWER SUPPLY P.C.B.

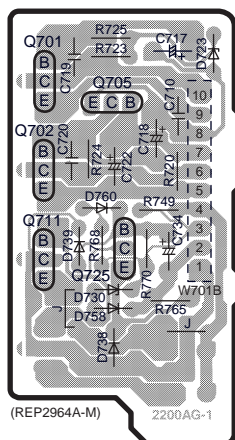

ELECTRICAL PARTS LOCATION

Ref. No.	Lo. No.	Ref. No.	Lo. No.	Ref. No.	Lo. No.	Ref. No.	Lo. No.	Ref. No.	Lo. No.	Ref. No.	Lo. No.	Ref. No.	Lo. No.	Ref. No.	Lo. No.
MAIN P.C.B.															
IC201	2D	D658	3D	RL701	5C	R559	2D	R627	4E	R688	3E	C604	3E	C649	4E
IC601	5F	D659	2B	CN781	2B	R561	2D	R628	3E	R691	4E	C605	4E	C650	4E
Q503	3D	D701	5D	CP101	1D	R563	2C	R629	3B	R702	7C	C606	4E	C659	3E
Q551	2D	D702	5C	CP601	8E	R564	2C	R631	3E	R703	5D	C607	3E	C660	3E
Q554	2D	D703	4D	CP602	8D	R570	2D	R632	3E	R704	5D	C608	3E	C666	7E
Q555	3D	D704	5C	CP603	8C	R571	3D	R635	2B	R705	5D	C609	4E	C701	7C
Q558	3D	D705	4C	JK601	8E	R572	3D	R637	3D	R707	4C	C610	4E	C702	6C
Q601	2E	D715	4C	JK602	7E	R591	2D	R638	3D	R708	4C	C611	4E	C703	6C
Q602	2E	D717	4C	E601	7E	R597	2C	R639	6E	R712	2B	C612	3E	C704	6C
Q605	2E	D718	4C	E602	3E	R598	2C	R640	5E	R719	2B	C613	3E	C705	2B
Q606	2E	D719	4C	W501	2C	R601	3E	R641	7D	R721	4D	C614	3E	C706	3C
Q607	3E	D720	4C	W721	5C	R602	3E	R642	5E	R722	4D	C616	4E	C707	4C
Q608	3E	D721	3C	W722	5C	R603	3E	R643	6D	R727	3E	C617	4E	C708	3C
Q617	8C	D725	3E	W901A	3C	R604	3E	R644	6D	R729	3E	C618	4E	C709	3D
Q618	8C	D736	4D	W902A	2B	R605	2E	R645	6D	R738	3D	C619	3D	C714	4C
Q703	3D	D737	1C	R202	3D	R606	2E	R646	7D	R739	4D	C620	6E	C715	4C
Q706	4D	D749	3E	R203	2D	R607	3E	R647	4E	R763	1C	C621	7D	C721	3E
Q707	3C	D751	5D	R204	2D	R608	3E	R648	4E	R764	1C	C622	3E	C723	3D
Q708	4D	D752	5C	R211	3D	R609	4E	R649	4D	R766	4C	C624	7E	C724	3D
Q709	4D	D753	5D	R229	2D	R610	4E	R650	4D	R767	3D	C625	7D	C731	4C
Q723	1B	D754	7C	R230	2C	R611	4E	R651	7D	R776	3D	C626	7E	C732	7D
D201	3D	D755	5C	R544	3D	R612	4E	R652	7E	R797	3D	C627	7D	C733	1C
D551	2E	D756	3D	R546	4E	R614	3E	R667	8C	C201	3D	C631	8E	C735	1D
D552	2D	D757	2D	R547	4E	R615	3E	R668	8C	C202	3C	C632	7E	C737	4C
D555	2D	D761	5C	R548	4E	R617	2E	R669	7C	C550	2D	C635	8E	C740	1C
D558	3D	L601	7E	R551	3E	R618	2E	R670	7C	C551	2D	C636	7E	C741	5C
D563	3D	L602	5E	R552	3E	R619	4E	R672	8C	C552	2D	C637	8E	C761	6C
D601	5E	L603	6D	R553	3E	R620	4E	R675	7C	C553	2E	C639	7D		
D602	5E	L604	6D	R554	4E	R621	3E	R683	2E	C554	2D	C640	7D		
D607	1B	L605	5D	R555	3E	R622	3E	R684	2E	C564	3D	C641	8D		
D613	7D	L606	4D	R556	2E	R623	4E	R685	2E	C601	2C	C642	7D		
D614	7D	RL602	7E	R557	2D	R624	4E	R686	2E	C602	2D	C647	3E		
D657	2B	RL605	8D	R558	2D	R626	3B	R687	3E	C603	3E	C648	4E		
POWER SUPPLY P.C.B.															
Q701	2I	Q725	2I	D739	2I	R720	2I	R749	2I	C710	2I	C720	2I		
Q702	2I	D723	2I	D758	3I	R723	2I	R765	3I	C717	2I	C722	2I		
Q705	2I	D730	3I	D760	2I	R724	2I	R768	2I	C718	2I	C734	2I		
Q711	2I	D738	3I	W701B	2I	R725	1I	R770	2I	C719	2I				

A B C D E F

D AC IN P.C.B.

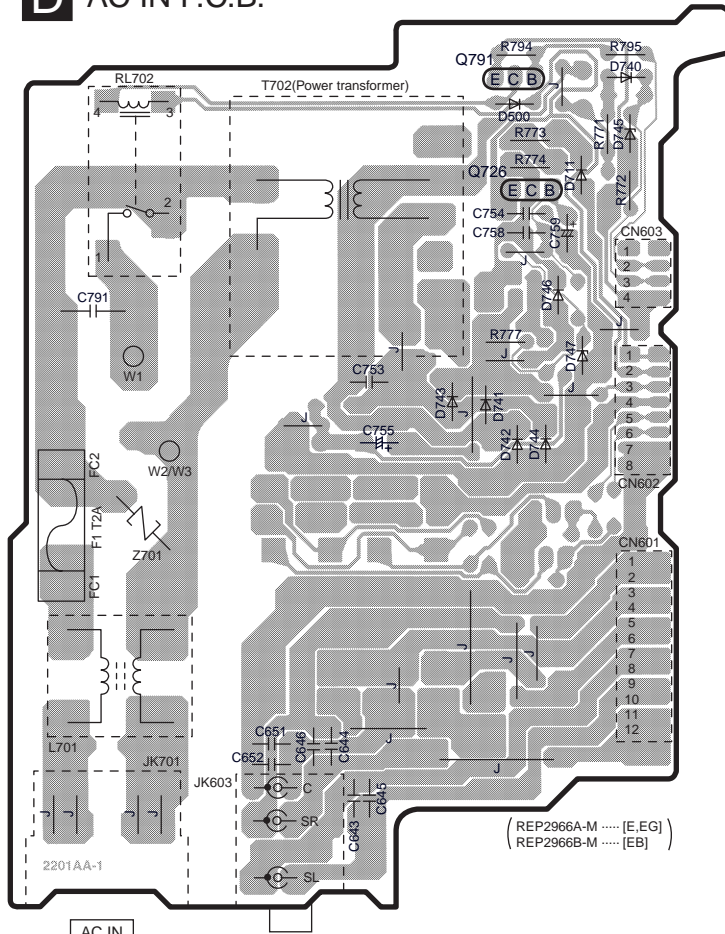

(230V 50Hz [E,EG])
 (230-240V 50Hz [EB])

ELECTRICAL PARTS LOCATION

Ref. No.	Lo. No.	Ref. No.	Lo. No.
D SPEAKER TERMINAL P.C.B.			
Q726	2D	FC2	3A
Q791	1C	W1	2B
D500	1C	W2/W3	3B
D711	2D	R771	1D
D740	1D	R772	2D
D741	3C	R773	1D
D742	3D	R774	2D
D743	3C	R777	2C
D744	3D	R794	1C
D745	1D	R795	1D
D746	2D	C643	4C
D747	2D	C644	4C
L701	4B	C645	4C
T702	2C	C646	4C
Z701	3B	C651	4B
F1	3A	C652	4B
RL702	2B	C753	3C
CN601	4D	C754	2D
CN602	3D	C755	3C
CN603	2D	C758	2D
JK603	5B	C759	2D
JK701	5B	C791	2B
FC1	3A		
E POWER TRANSFORMER(A) P.C.B.			
CN701	6B	CN709	8B
CN702	6B	CN710	8B
CN703	7B	W21	7A
CN704	7B	W22	7A
CN705	7B	R791	8A
CN706	7B	R792	8A
CN707	7B	R793	6A
CN708	8B		
F POWER TRANSFORMER(B) P.C.B.			
CN711	6D	W1	6E
CN712	7D	W2	7E
CN713	7D	W3	7E

E POWER TRANSFORMER (A) P.C.B.

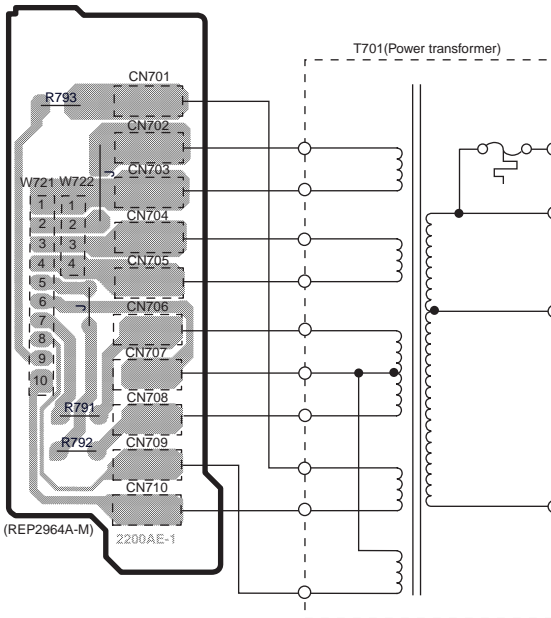

F POWER TRANSFORMER (B) P.C.B.

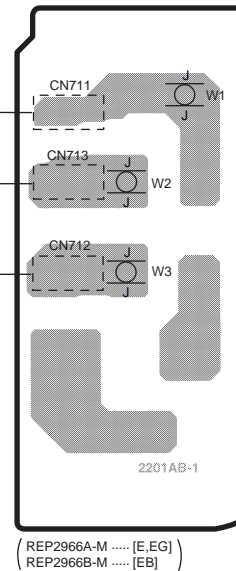

(REP2966A-M [E,EG])
 (REP2966B-M [EB])

1
2
3
4
5
6
7
8

SCHEMATIC DIAGRAM - 1

A OPERATION CIRCUIT

NOTE: The number which noted at the connectors on the schematic diagram as "SCHEMATIC DIAGRAM-1" or "SCHEMATIC DIAGRAM-2" indicates the schematic diagram serial number located on the left corner in the schematic diagram.

□▷ : SOURCE SIGNAL LINE

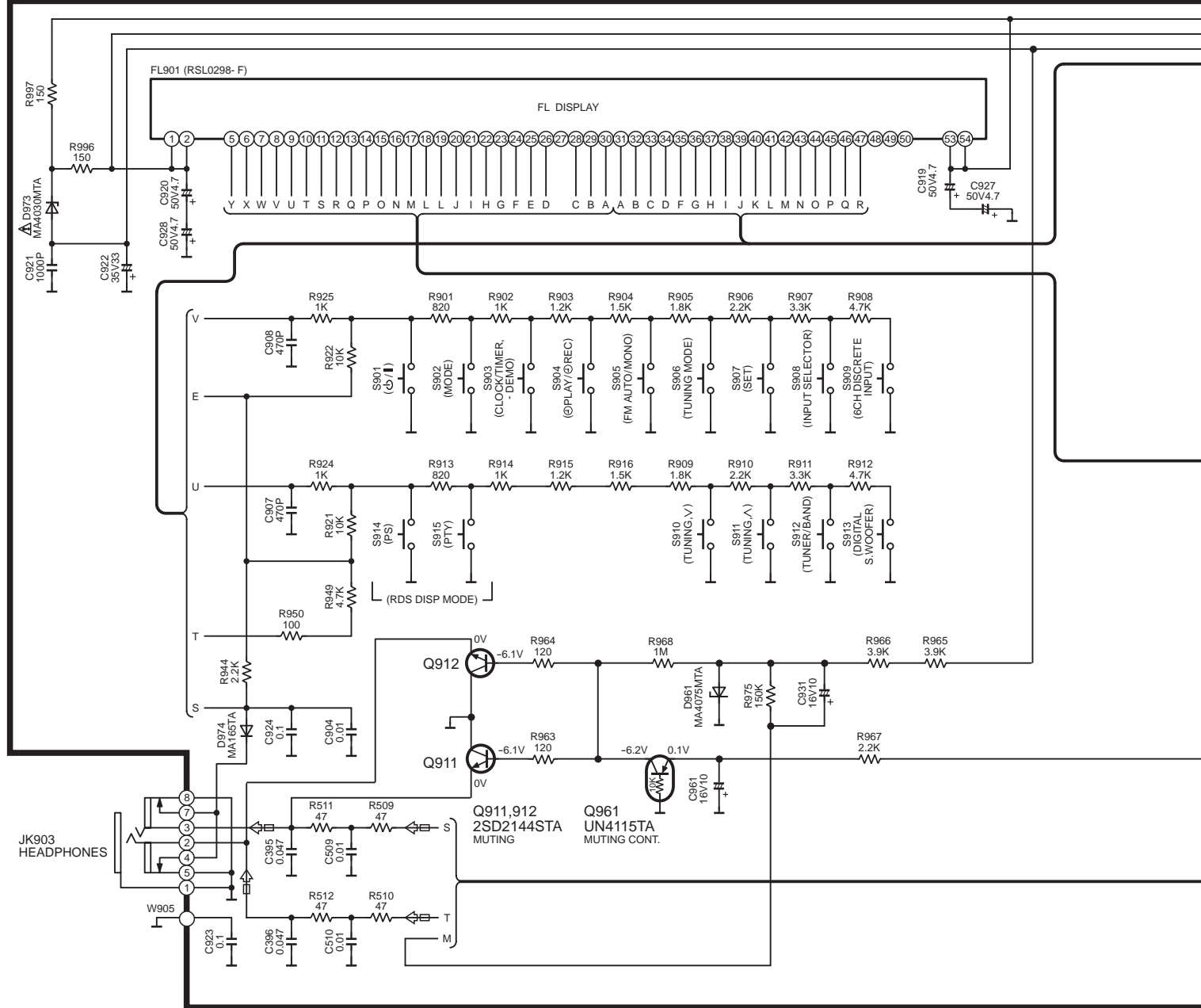

SCHEMATIC DIAGRAM- 4

B MAIN CIRCUIT



To MAIN CIRCUIT of SOUND PROCESSOR

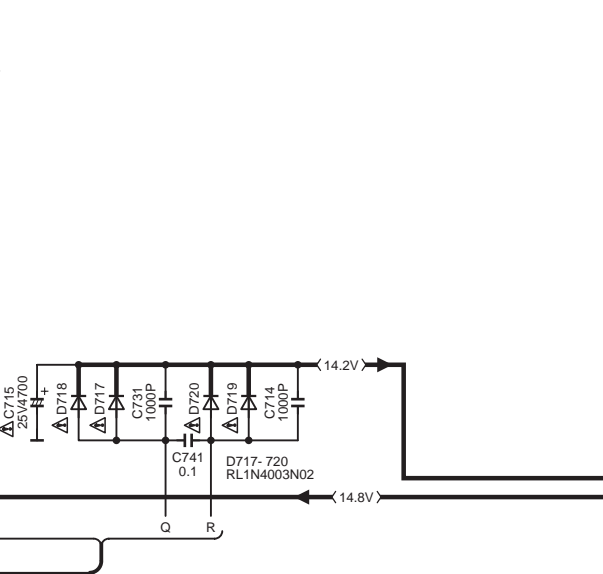
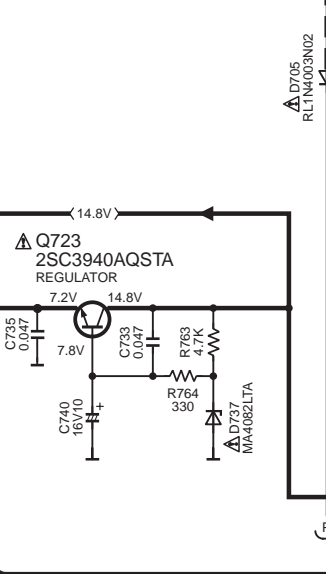
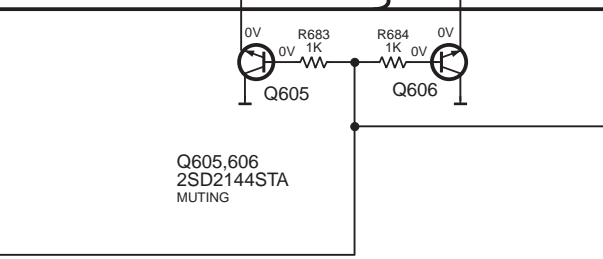
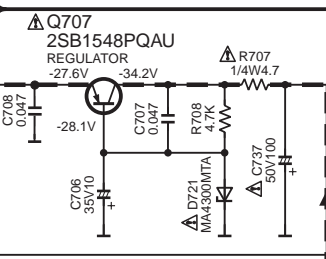
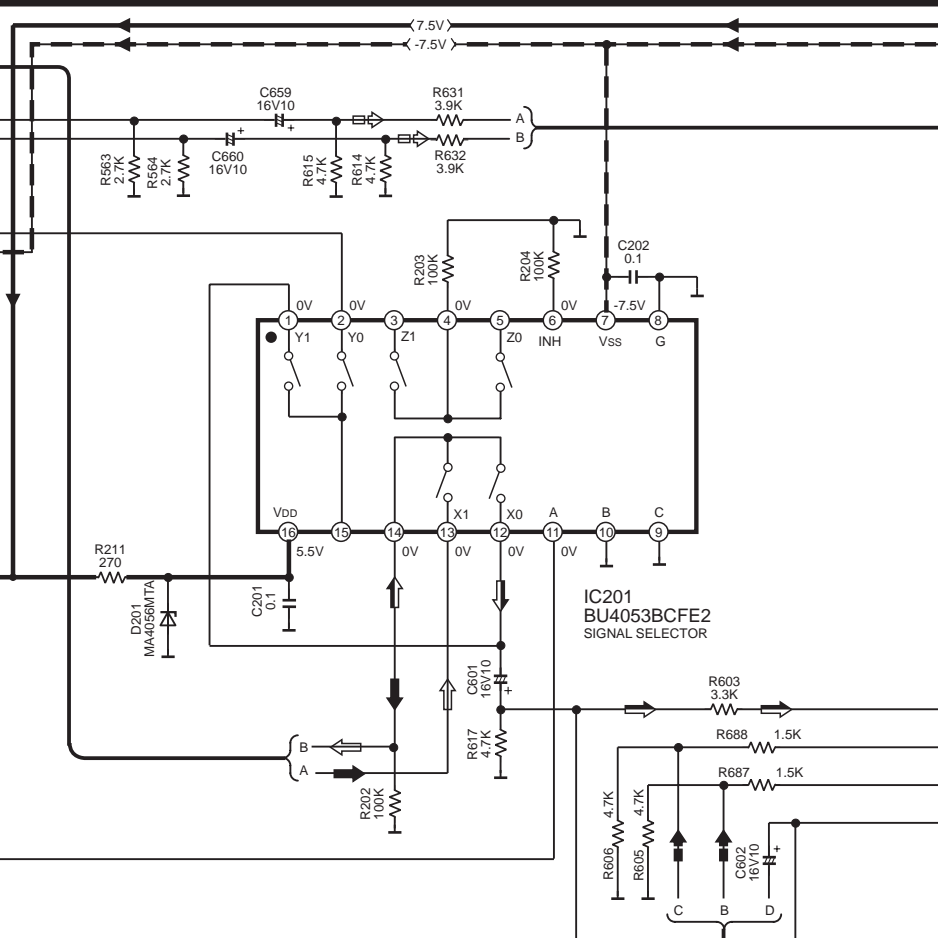
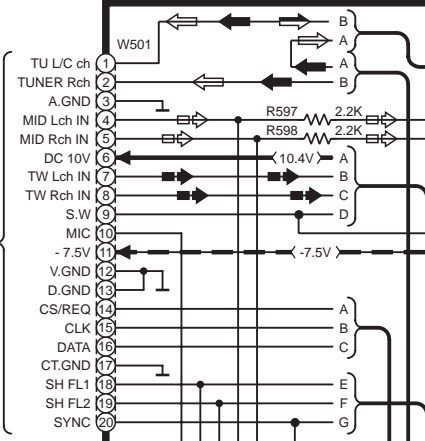

To TUNER UNIT on SCHEMATIC DIAGRAM- 9

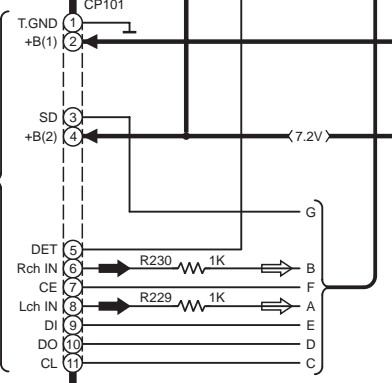

SCHEMATIC DIAGRAM- 5

→ : POSITIVE VOLTAGE LINE ◀ : SURROUND SP.DRIVE SIGNAL LINE

--- : NEGATIVE VOLTAGE LINE ⇨ : CENTER SP.DRIVE SIGNAL LINE □◇ : SOURCE SIGNAL LINE

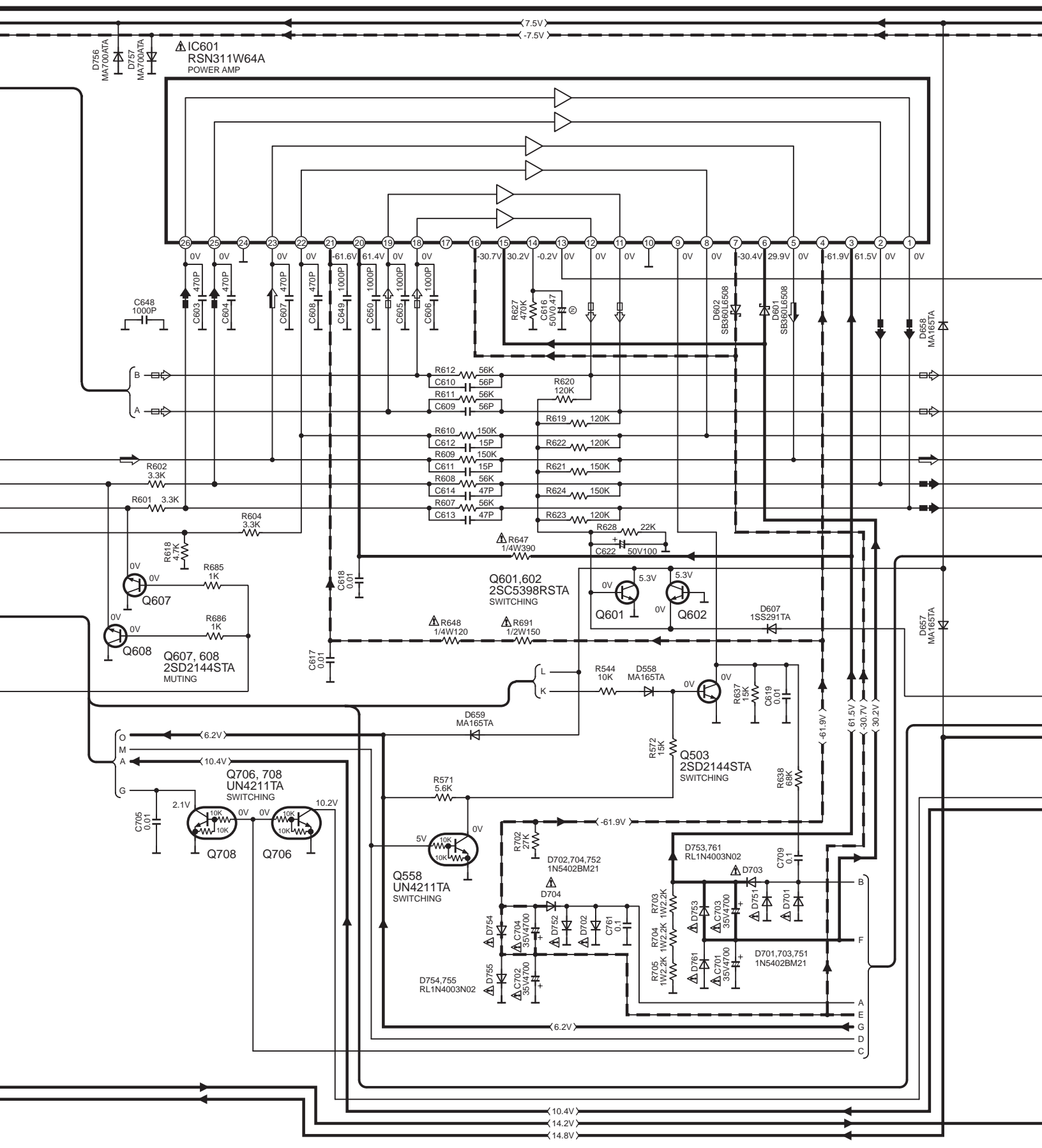

SCHEMATIC DIAGRAM-6

B MAIN CIRCUIT

→ : POSITIVE VOLTAGE LINE
 → : NEGATIVE SP.DRIVE SIGNAL LINE
 → : CENTER SP.DRIVE SIGNAL LINE
 ◇ : SOURCE SIGNAL LINE

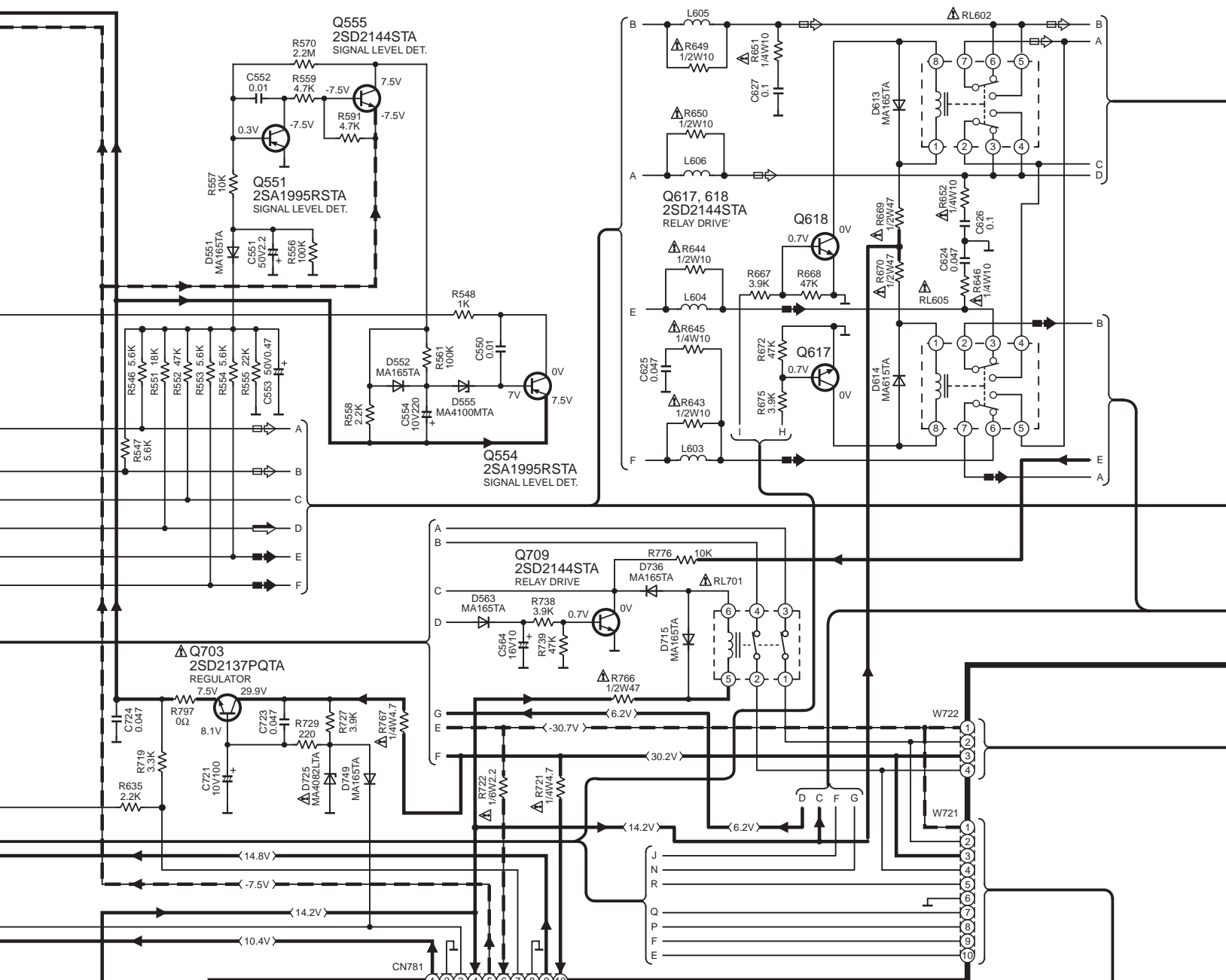

C POWER SUPPLY CIRCUIT

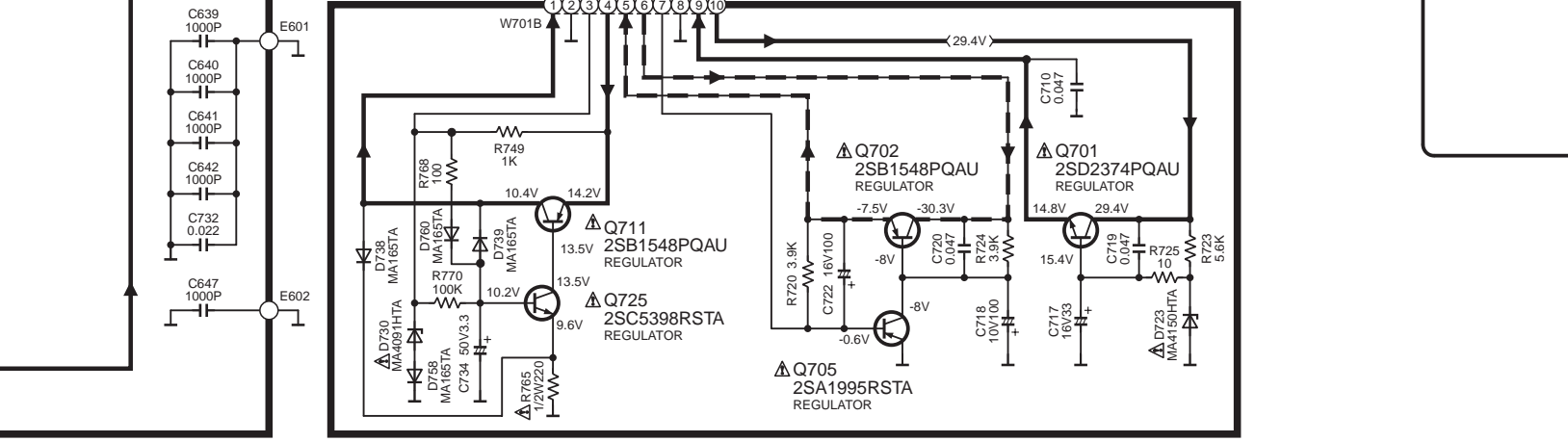

SCHEMATIC DIAGRAM- 7

D

AC IN CIRCUIT

- : POSITIVE VOLTAGE LINE
- ⇨ : SOURCE SIGNAL LINE
- : NEGATIVE VOLTAGE LINE
- : SURROUND SP.DRIVE SIGNAL LINE
- ⇨ : CENTER SP.DRIVE SIGNAL LINE

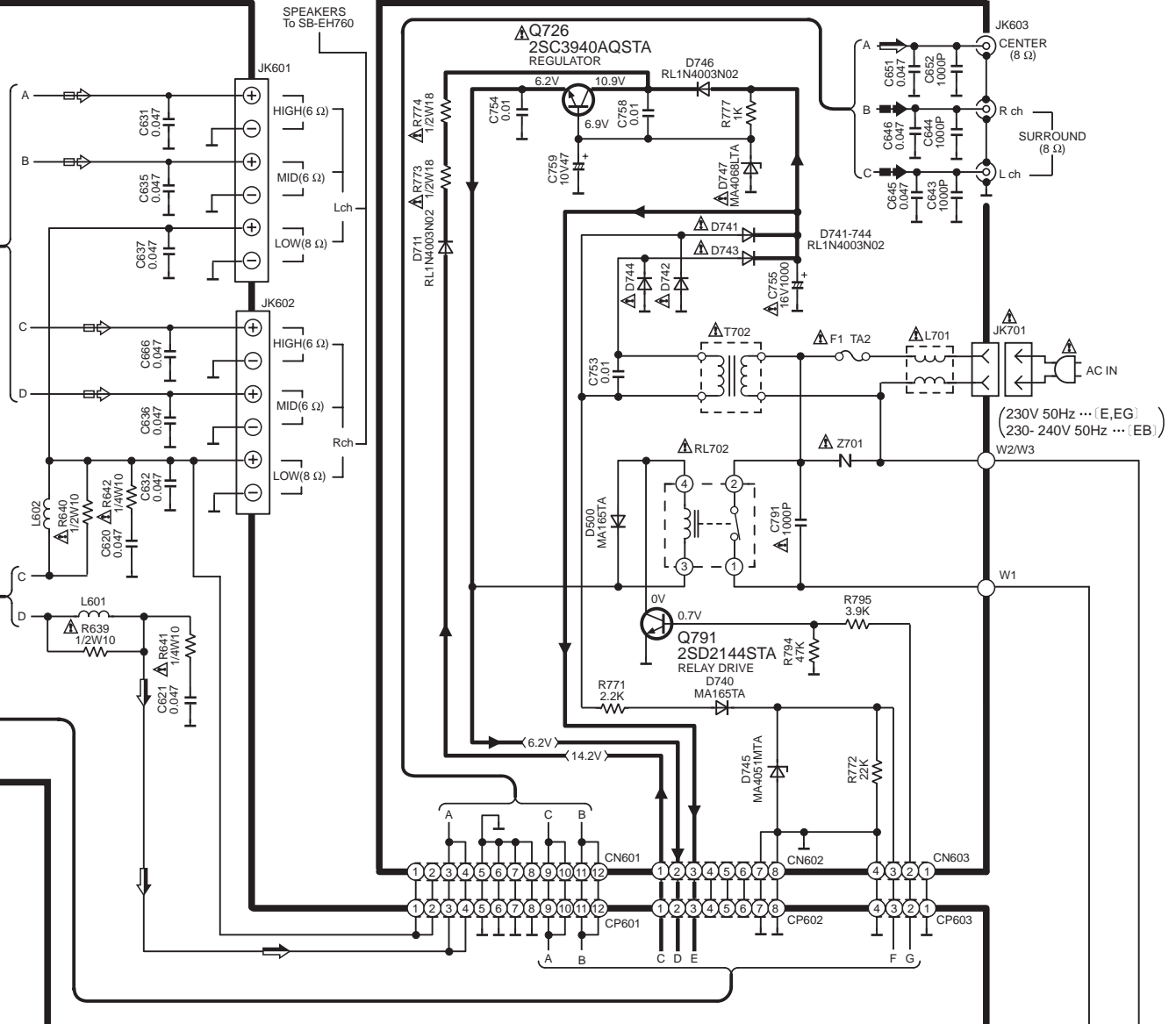

E

POWER TRANSFORMER (A) CIRCUIT

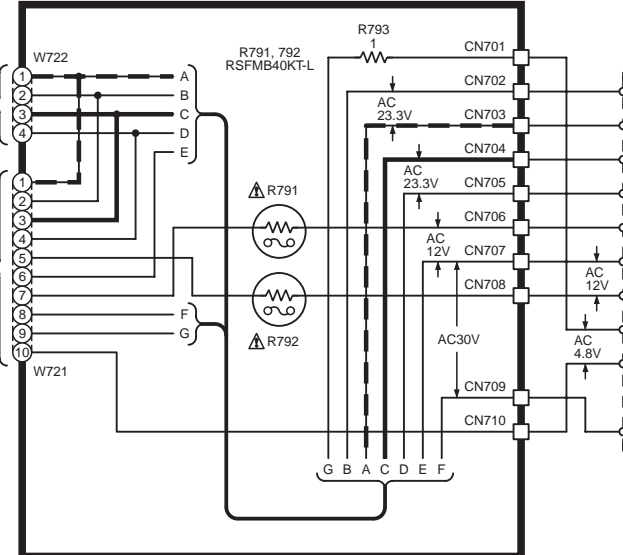

F

POWER TRANSFORMER (B) CIRCUIT

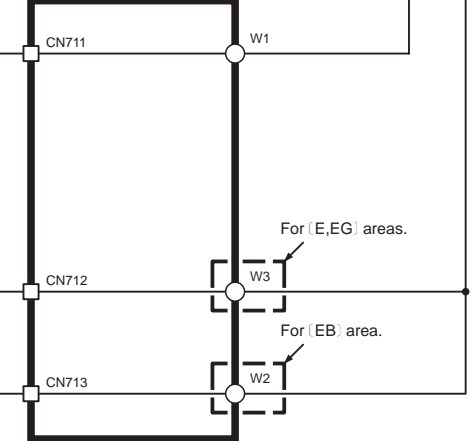

Z120 TUNER UNIT(RAN0005EM)

⇨ : FM SIGNAL LINE

➡ : AM SIGNAL LINE

➡ : POSITIVE VOLTAGE LINE

⇨ : FM OSC SIGNAL LINE

➡ : AM OSC SIGNAL LINE

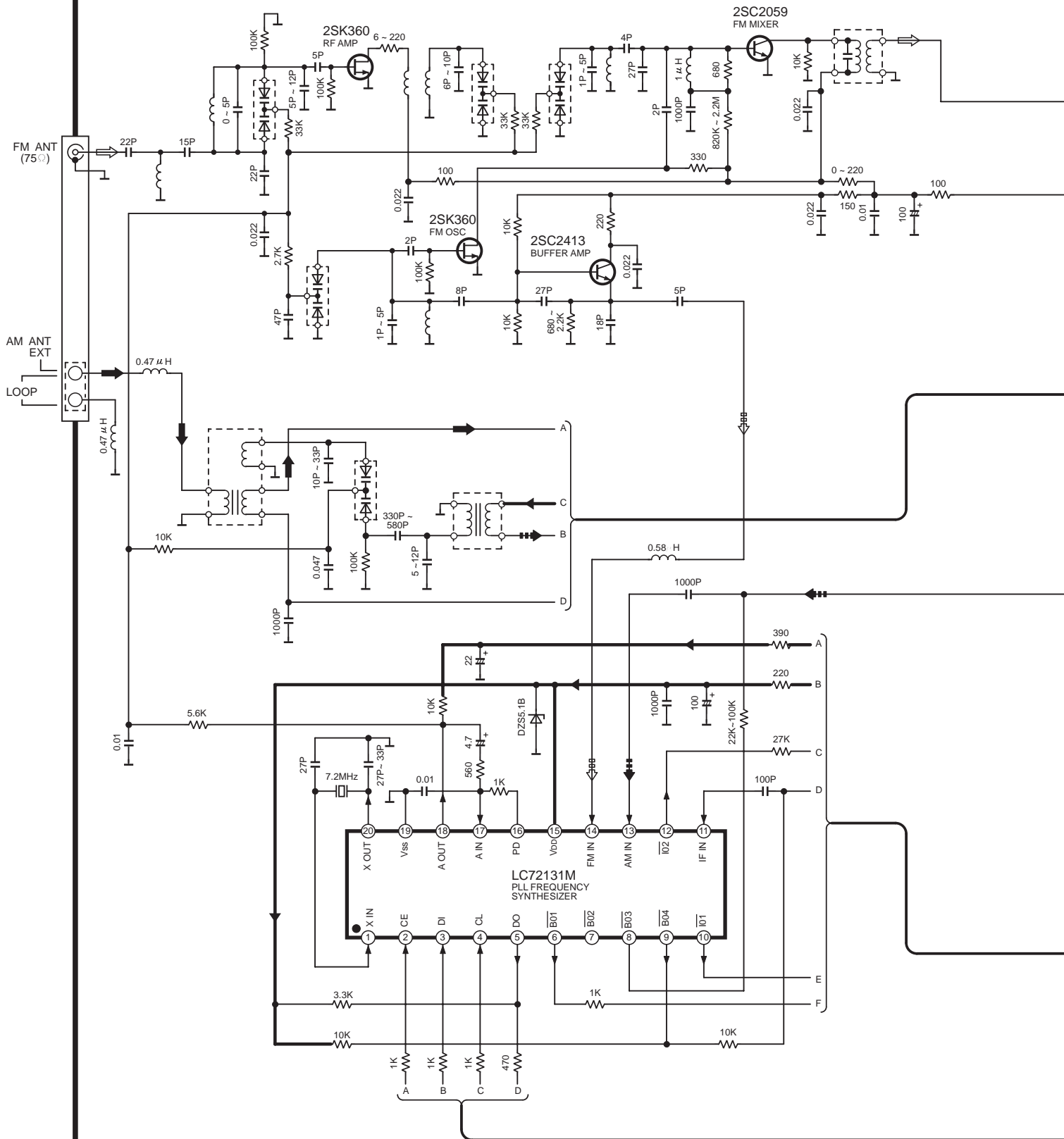

SCHEMATIC DIAGRAM-9

→ : POSITIVE VOLTAGE LINE ⇨ : FM SIGNAL LINE → : AM SIGNAL LINE ⇨⇨ : AM OSC SIGNAL LINE

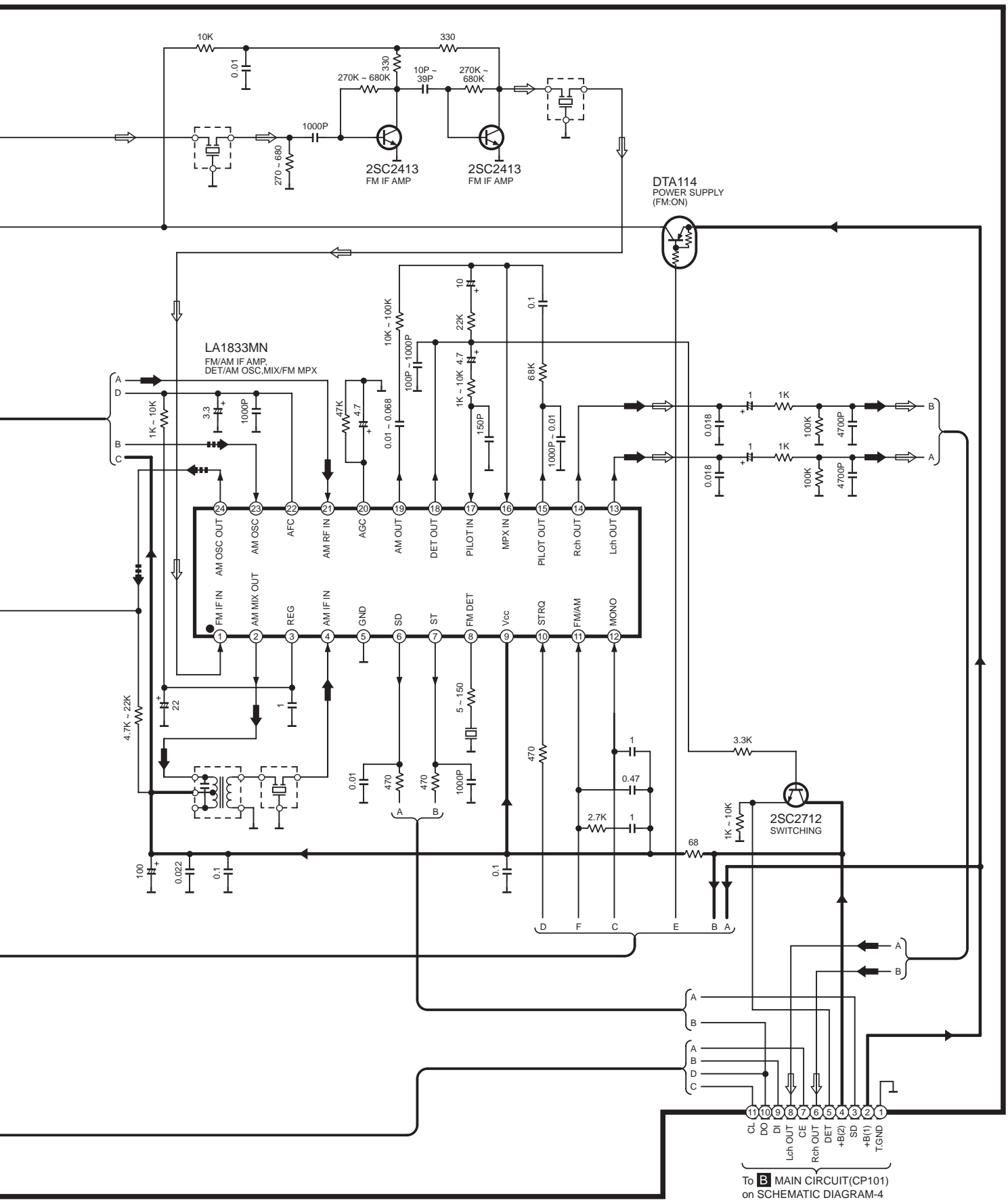

To **B** MAIN CIRCUIT(CP101)
on SCHEMATIC DIAGRAM-4

SCHEMATIC DIAGRAM - 1

A OPERATION CIRCUIT

NOTE: The number which noted at the connectors on the schematic diagram as "SCHEMATIC DIAGRAM-1" or "SCHEMATIC DIAGRAM-2" indicates the schematic diagram serial number located on the left corner in the schematic diagram.

□▷ : SOURCE SIGNAL LINE

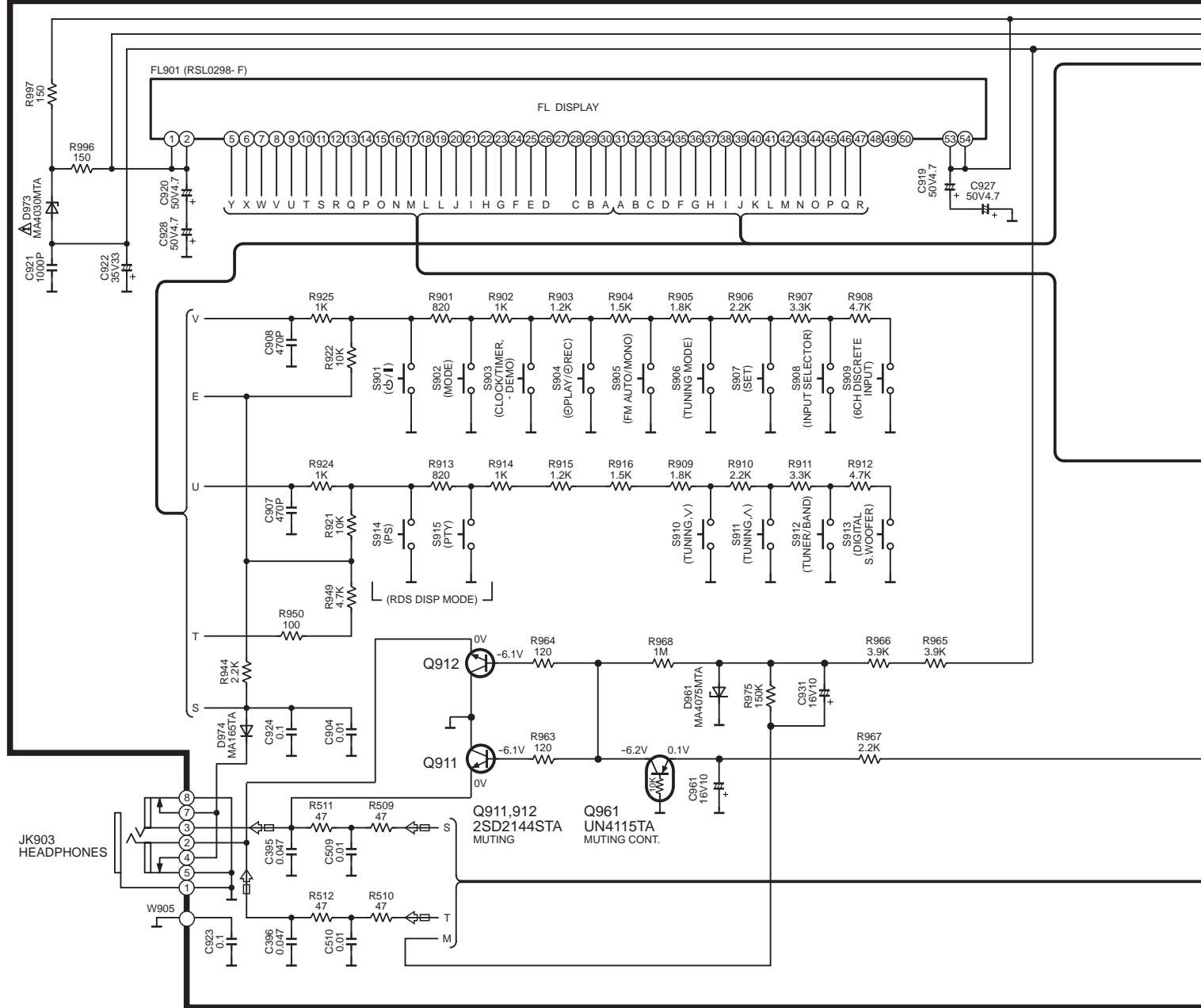

SCHEMATIC DIAGRAM- 4

B MAIN CIRCUIT



To MAIN CIRCUIT of SOUND PROCESSOR

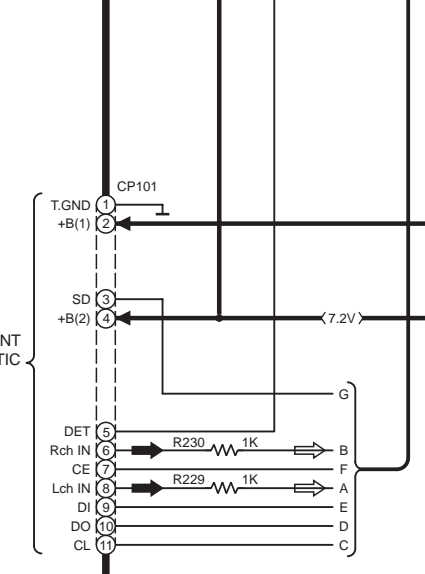
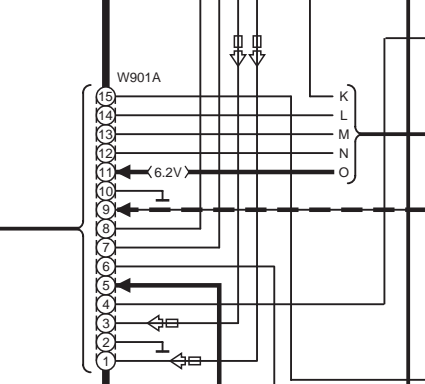
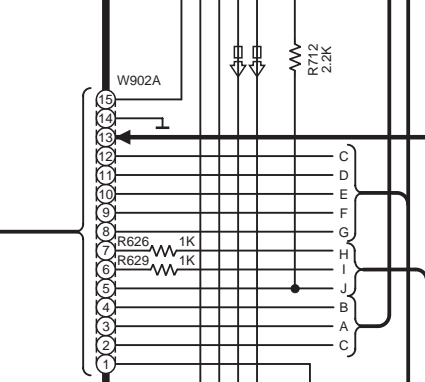
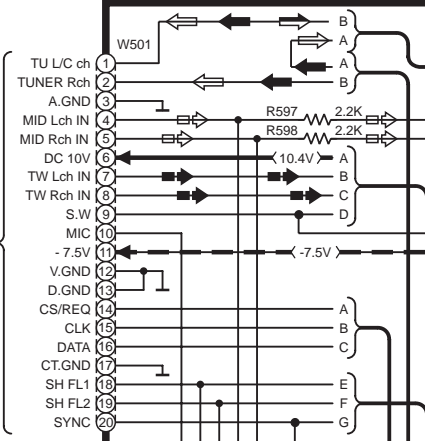

To TUNER UNIT on SCHEMATIC DIAGRAM- 9

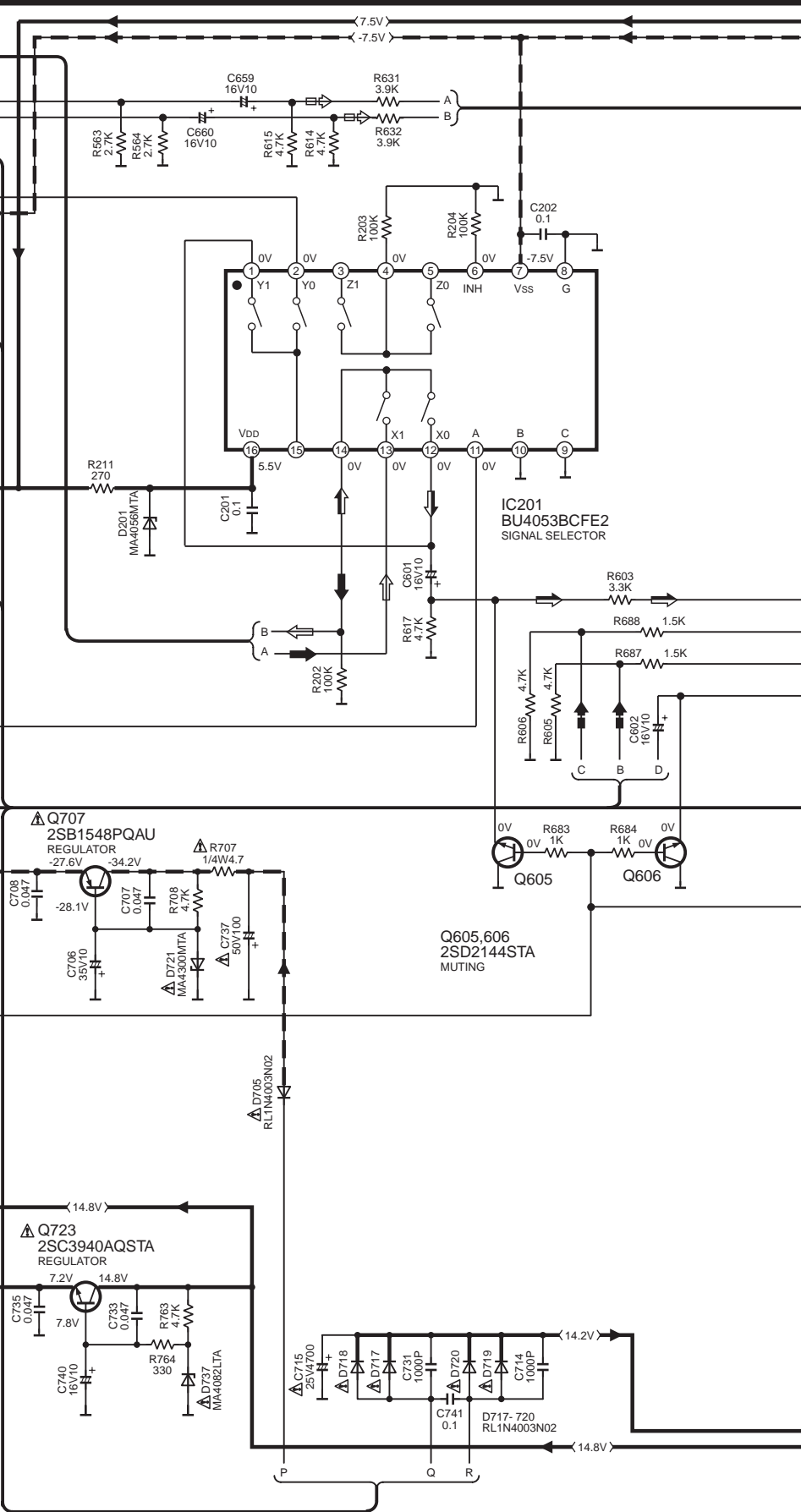

SCHEMATIC DIAGRAM-6

B MAIN CIRCUIT

→ : POSITIVE VOLTAGE LINE
 → : NEGATIVE SP.DRIVE SIGNAL LINE
 → : CENTER SP.DRIVE SIGNAL LINE
 ◇ : SOURCE SIGNAL LINE

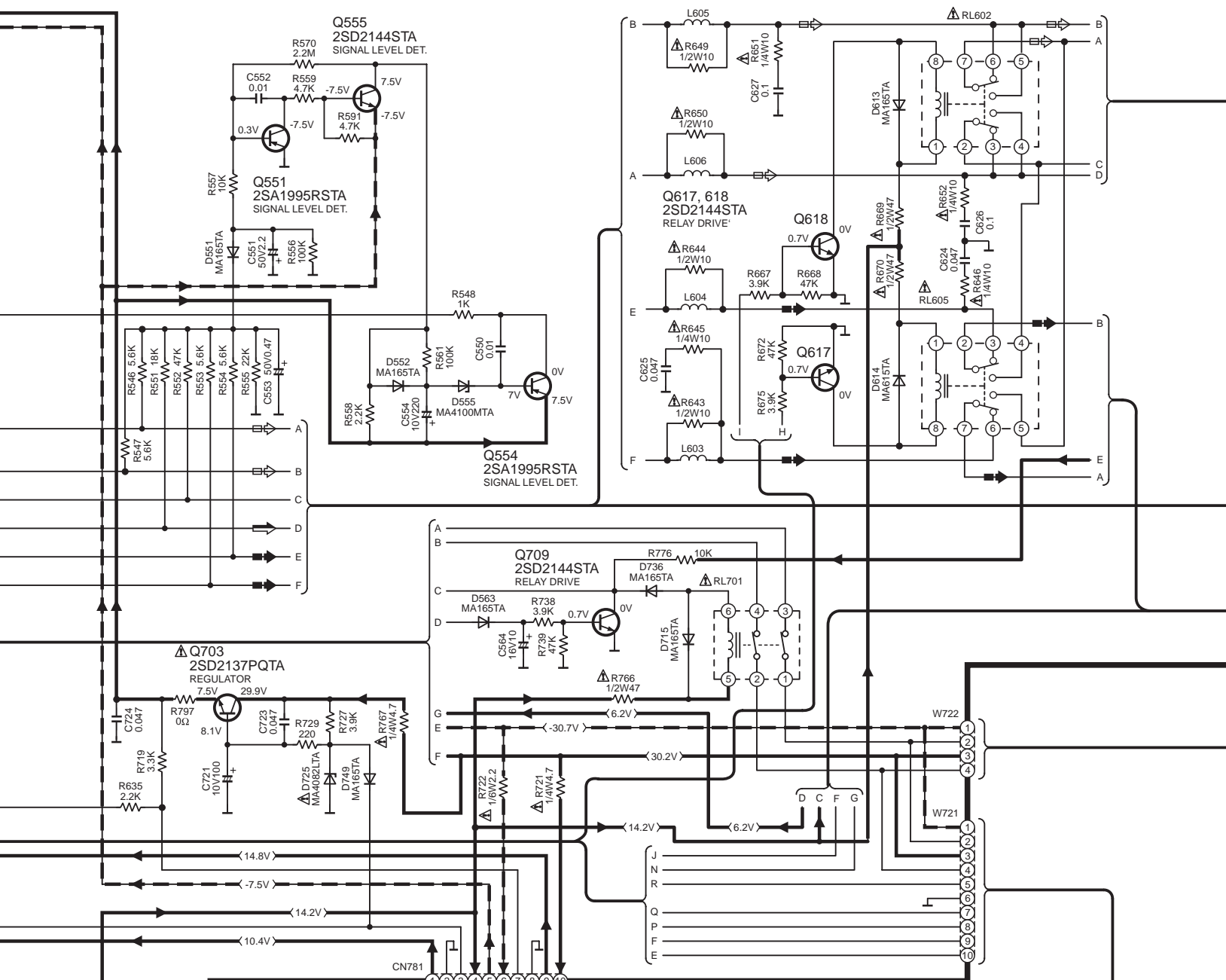

C POWER SUPPLY CIRCUIT

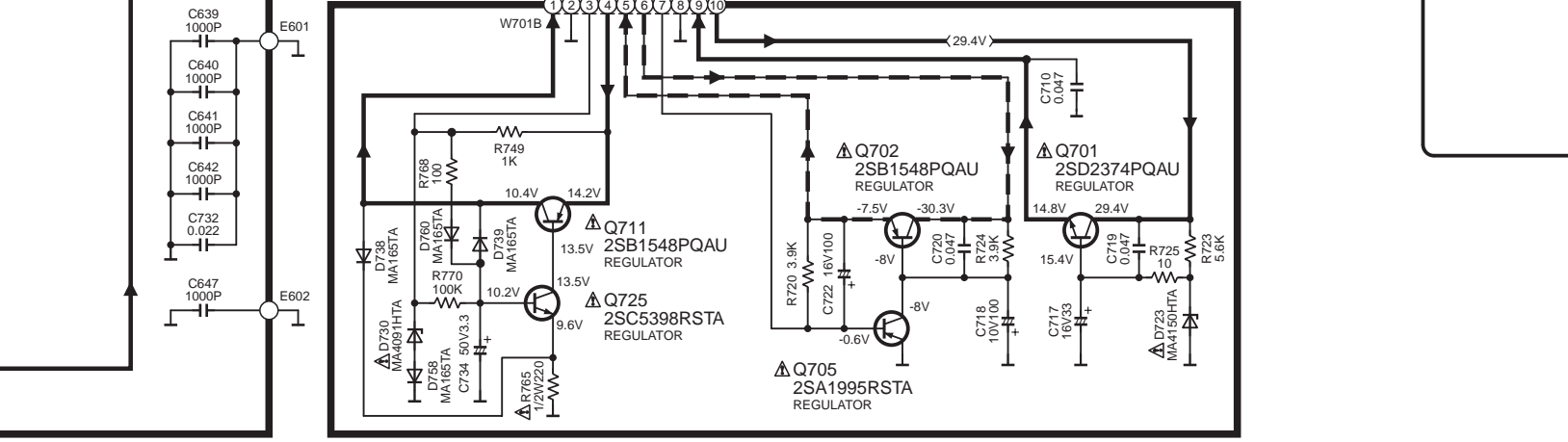

SCHEMATIC DIAGRAM- 7

D AC IN CIRCUIT

- : POSITIVE VOLTAGE LINE
- ⇨ : SOURCE SIGNAL LINE
- : NEGATIVE VOLTAGE LINE
- : SURROUND SP.DRIVE SIGNAL LINE
- ⇨ : CENTER SP.DRIVE SIGNAL LINE

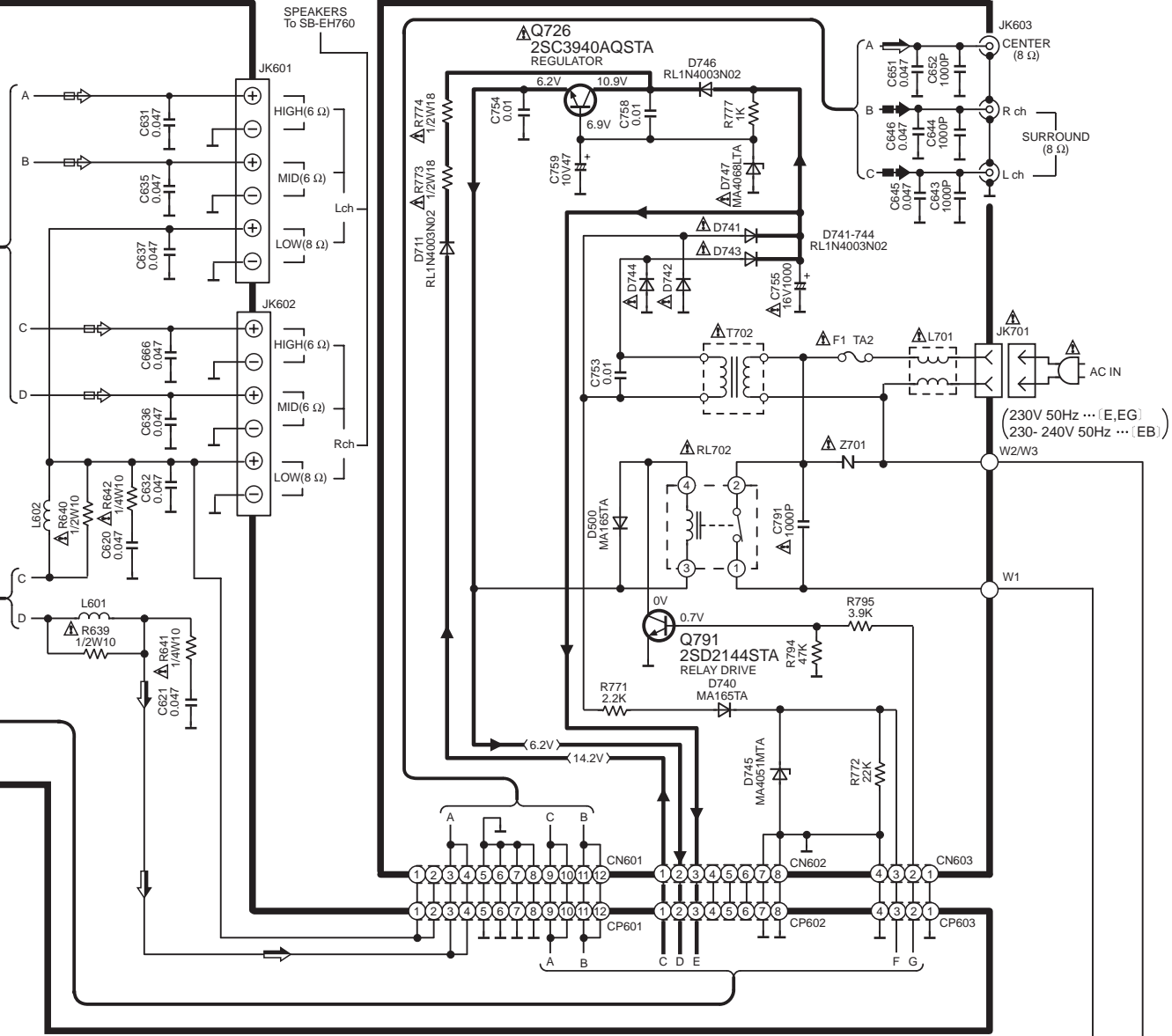

E POWER TRANSFORMER (A) CIRCUIT

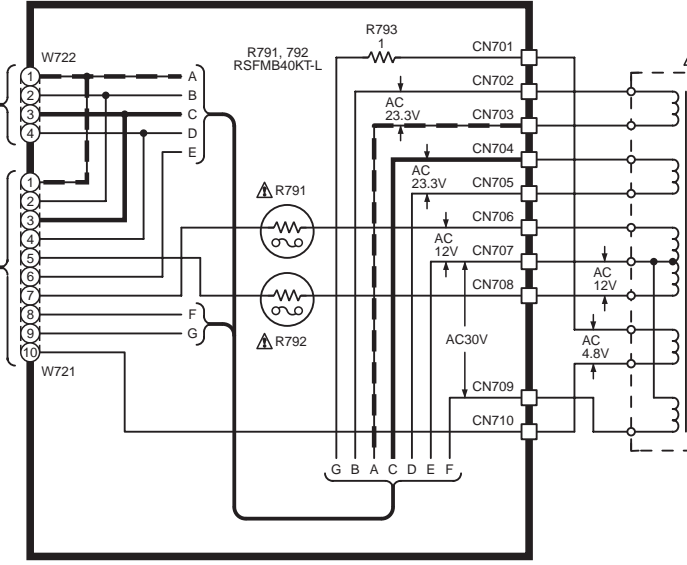

F POWER TRANSFORMER (B) CIRCUIT

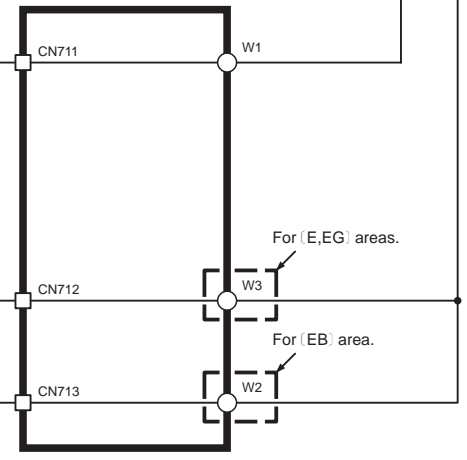

SCHEMATIC DIAGRAM-9

→ : POSITIVE VOLTAGE LINE ⇨ : FM SIGNAL LINE → : AM SIGNAL LINE ⇨⇨ : AM OSC SIGNAL LINE

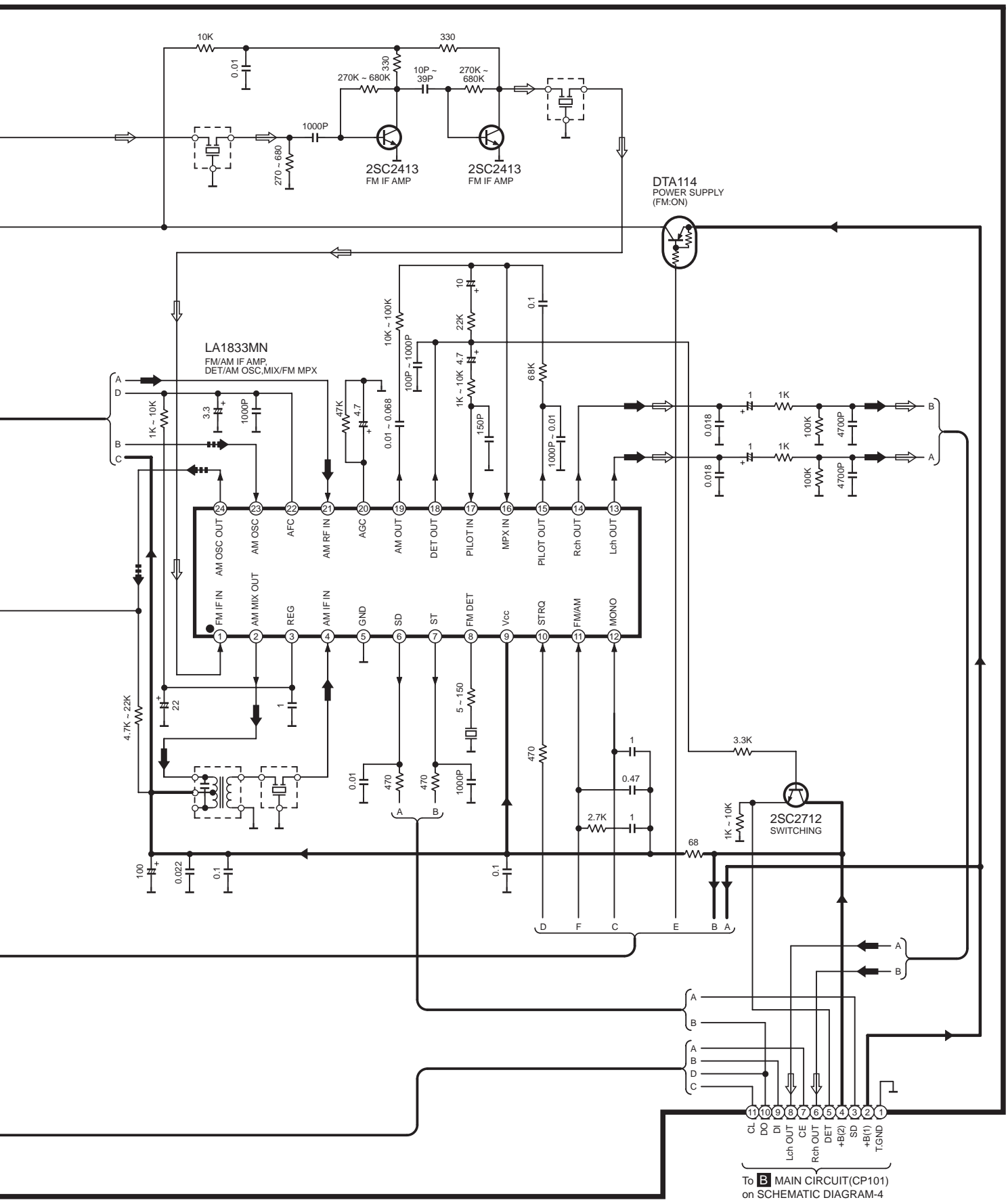

To **B** MAIN CIRCUIT(CP101)
on SCHEMATIC DIAGRAM-4

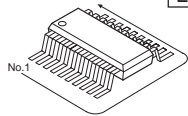

BU4053BCFE2	16PIN
LC72721NMTLM	20PIN

LC8A524A5N28

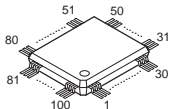

RSN311W64A

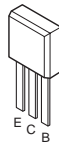
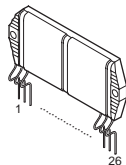

2SD2137PQTA
UN411FTA
UN4115TA
UN4211TA
UN4212TA

2SA1995RSTA
2SC5398RSTA

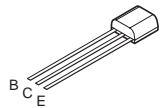

2SC3940AQSTA

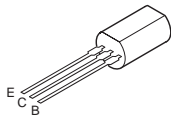

2SB1548PQAU
2SD2374PQAU

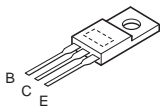

2SA1995RSTA
2SC5398RSTA
2SD2144STA

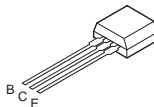

MA4091HTA
MA4100MTA
MA4150HTA
MA4300MTA

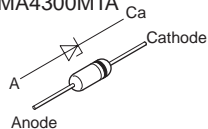

MA165TA
MA700ATA
1SS291TA

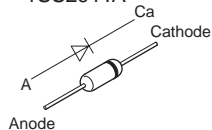

SB360L6508

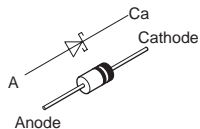

1N5402BM21
RL1N4003N02

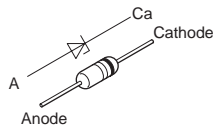
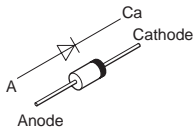

MA4030MTA
MA4051MTA
MA4056MTA
MA4068LTA
MA4075MTA
MA4082LTA

LNJ301MPUJAD

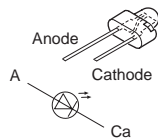

SELS5223C
SELS5923C

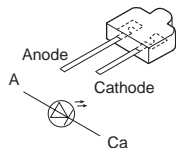

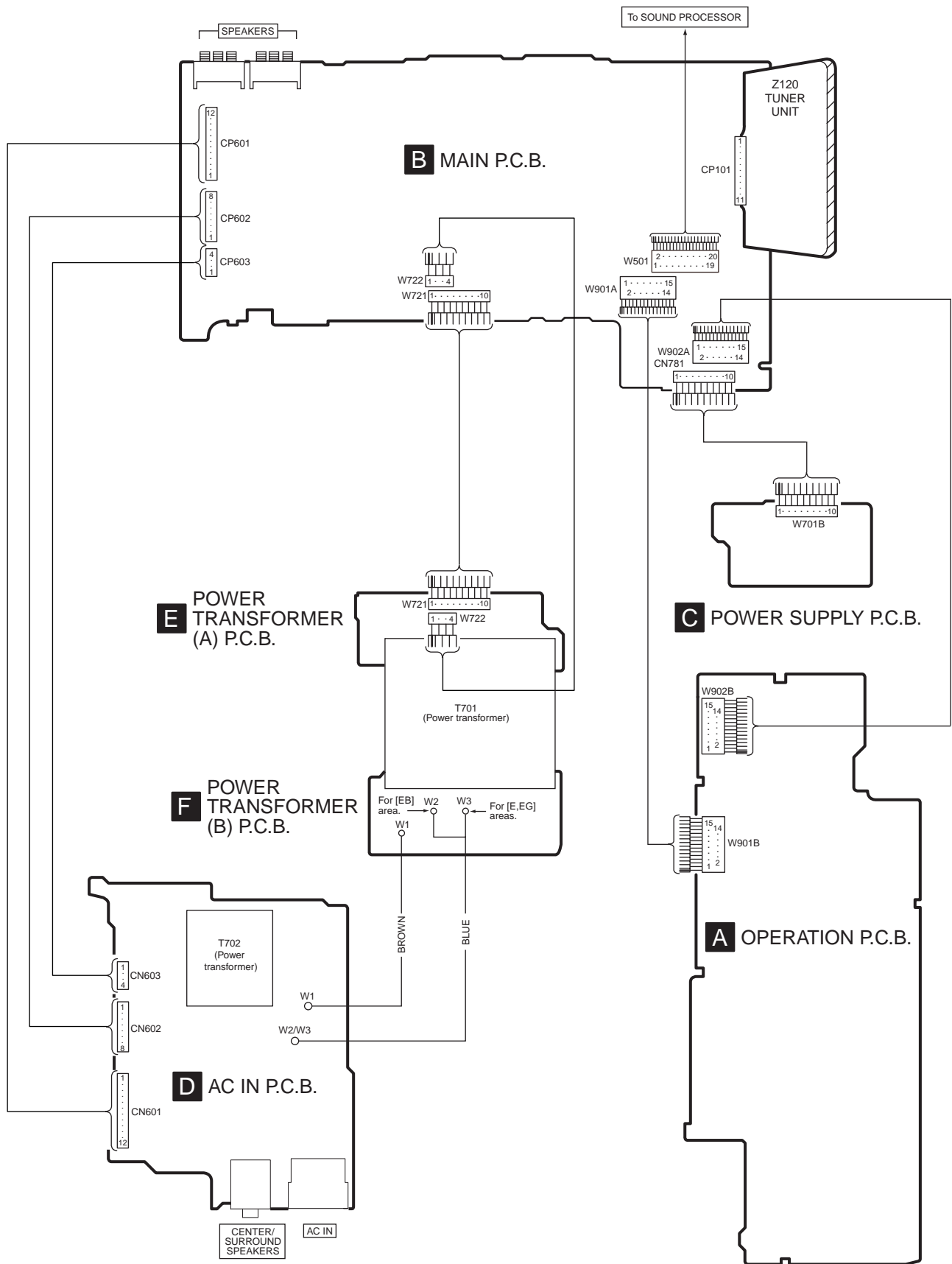

CD Changer
(SL-EH760)

Sound processor
(SH-EH760)

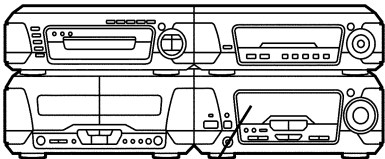

Cassette deck
(RS-EH760)

Tuner/Amplifier
(SA-EH760)

U70CD

U70DECK

Flat cable

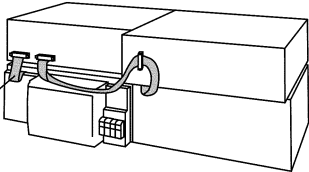

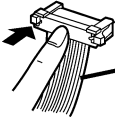

White side

**Servizi
Manuali**



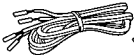
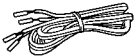

Because of unique interconnecting cables, when a component requires service, send or bring in the entire system.

Specifications

Amplifier section

Power output (L/R both channel driven):

Stereo mode:

DIN	10 kHz, THD 1 % (High)	2 × 20 W (6 Ω)
	1 kHz, THD 1 % (Mid)	2 × 20 W (6 Ω)
	100 Hz, THD 1 % (Low)	2 × 50 W (8 Ω)
RMS	10 kHz, THD 10 % (High)	2 × 30 W (6 Ω)
	1 kHz, THD 10 % (Mid)	2 × 30 W (6 Ω)
	100 Hz, THD 10 % (Low)	2 × 70 W (8 Ω)

PRO LOGIC mode:

DIN FRONT	1 kHz, THD 1 % /TTL Imp. (High/Mid);	2 × 20 W (6 Ω)
	100 Hz, THD 1 % (Low);	2 × 50 W (8 Ω)
SURROUND	1 kHz, THD 1 %;	2 × 20 W (8 Ω)
CENTER	1 kHz, THD 1 %;	50 W (8 Ω)
RMS FRONT	1 kHz, THD 10 % /TTL Imp. (High/Mid);	2 × 30 W (6 Ω)
	100 Hz, THD 10 % (Low);	2 × 70 W (8 Ω)
SURROUND	1 kHz, THD 10 %;	2 × 30 W (8 Ω)
CENTER	1 kHz, THD 10 %;	70 W (8 Ω)
PMPO 1 kHz:	3,000 W (High or Mid 6 Ω, Low, CENT., SURR. 8 Ω)	

Total harmonic distortion:

Rated power at 1 kHz;	1 % (6 Ω)
Half power at 1 kHz;	0.1 % (6 Ω)

Load impedance:

FRONT (High/Mid);	total impedance 6 Ω
(Low);	8 Ω
SURROUND;	8 Ω
CENTER; 8 Ω	

S.WOOFER:

Center frequency;	70 Hz
LEVEL (VOL-20 dB):	MID +8 dB, MAX +12 dB

FM tuner section

Frequency range:	87.50 – 108.00 MHz (0.05 MHz steps)
Sensitivity:	1.8 μV (IHF usable)
S/N 26 dB:	1.5 μV
S/N (MONO):	70 dB (75 dB, IHF)
Antenna terminal(s):	75 Ω (unbalanced)

AM tuner section

Frequency range:	522 – 1629 kHz (9 kHz steps)
	520 – 1630 kHz (10 kHz steps)
	500 μV/m

Sensitivity (S/N 20 dB):

Timer section

Clock:	Quartz - lock type
Function:	Play timer (1 time, daily), Rec timer (1 time, daily), Sleep (120 min, 30 min intervals)
Setting intervals (Play/Rec):	1 minute – 23 hours 59 minutes (1 min intervals)

General

Power supply:	AC 230 V, 50 Hz
(E), (EG) areas;	AC 230 – 240 V, 50 Hz
(EB) area;	205 W
Power consumption:	
Standby;	11 W
Normal mode	0.5 W
ECO mode	
Dimensions (W×H×D):	293×118.5×346 mm
Mass:	5.3 kg

Notes: Specifications are subject to change without notice.
Mass and dimensions are approximate.
Total harmonic distortion is measured by the digital spectrum analyzer.

System	SC-EH760
Sound Processor	SH-EH760
Tuner/Amplifier	SA-EH760
CD Changer	SL-EH760
Cassette Deck	RS-EH760
Front Speakers*	SB-EH760
Center Speaker*	SB-PC75
Surround Speakers*	SB-PS75

* : Made in Spain.



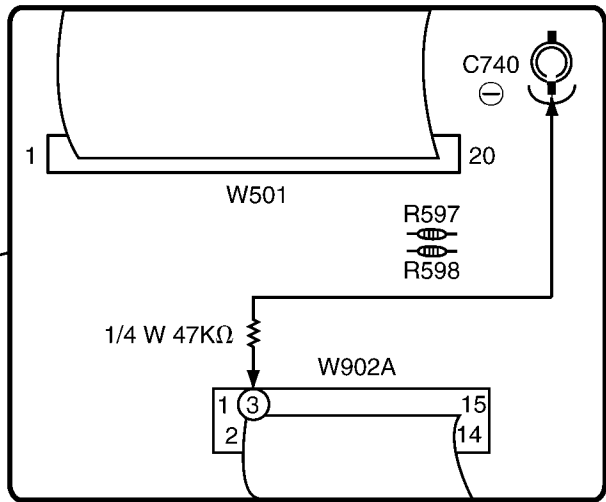
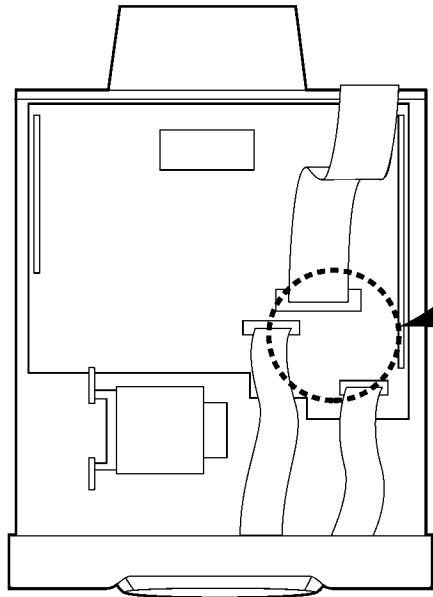







Technics®



WARNING

This service information is designed for experienced repair technicians only and is not designed for use by the general public. It does not contain warnings or cautions to advise non-technical individuals of potential dangers in attempting to service a product. Products powered by electricity should be serviced or repaired only by experienced professional technicians. Any attempt to service or repair the product or products dealt with in this service information by anyone else could result in serious injury or death.