

Service Manual

AV Control Stereo Receiver

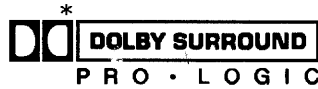

Receiver

SA-EX500

Colour

(K) Black Type

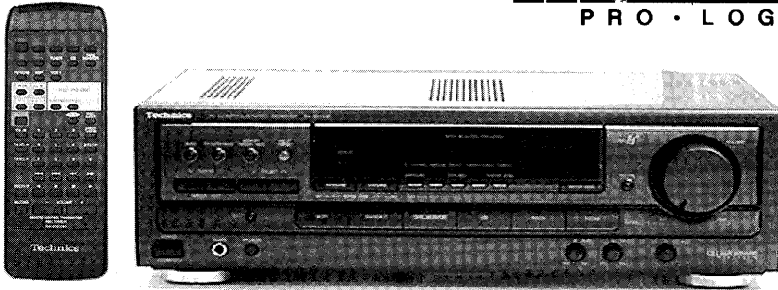

Area

Suffix for Model No.	Area	Colour
(E)	Europe	(K)
(EB)	Great Britain	
(EG)	Germany and Italy	

* Manufactured under license from Dolby Laboratories Licensing Corporation. Additionally licensed under one or more of the following patents: U.S. numbers 3,632,886, 3,746,792 and 3,959,590; Canadian numbers 1,004,603 and 1,037,877.

"Dolby" and the double-D symbol are trade marks of Dolby Laboratories Licensing Corporation.

Specifications

Amplifier Section

Power output (at 240V)	
DIN 1kHz (T.H.D. 1%)	2 x 100W (4Ω)
20 Hz–20 kHz continuous power output both channels driven	2 x 65W (8Ω)
Total harmonic distortion	
Rated power at 20 Hz – 20kHz	0.05% (8Ω)
Half power at 1 kHz	0.03% (8Ω)
Power output at the Dolby Pro Logic operation	
DIN 1 kHz (T.H.D. 1%)	
Front	2X60 W (4Ω)
Center	60 W (8Ω)
Surround	60 W (8Ω)
Damping factor	30 (8Ω)
Load impedance	
Front	4-16Ω
Center	8-16Ω
surround	4-16Ω
Intermodulation distortion	
rated power at 60Hz: 7kHz=4:1, SMPTE	0.5% (8Ω)
Power bandwidth	
both channels driven, -3dB	10Hz - 40kHz(8Ω)
Frequency response	
PHONO	RIAA standard curve (30Hz-15kHz) ± 0.8dB 10Hz – 40kHz, ± 3dB
CD, TAPE, VCR 1, TV/VCR 2	
Input sensitivity and impedance	
PHONO	3mV/47kΩ
CD, TAPE, VCR 1, TV/VCR 2	200mV/22kΩ
S/N at rated power (8Ω)	
PHONO	70dB (IHF, A: 80dB)
CD, TAPE, VCR 1, TV/VCR 2	75dB (IHF, A: 85dB)
Tone controls	
BASS	50Hz, +10 to -10dB
TREBLE	20kHz, +10 to -10dB
Output voltage	
VCR1 OUT, TAPE REC (OUT)	200mV

Channel balance (250Hz-6.3kHz)	±1dB
Channel separation	55dB
Headphones output level and impedance	430mV/330Ω

FM Tuner Section

Frequency range	87.5 — 108.0MHz
Sensitivity	
S/N 30dB	1.5μV/75Ω
S/N 26dB	1.3μV/75Ω
S/N 20dB	1.2μV/75Ω
IHF usable sensitivity	1.5μV/75Ω (IHF '58)
IHF 46dB stereo quieting sensitivity	22μV/75Ω
Total harmonic distortion	
MONO	0.2%
STEREO	0.3%
S/N	
MONO	60dB (75dB, IHF)
STEREO	58dB (71dB, IHF)
Frequency response	20Hz — 15 kHz (+1dB, -2dB)
Alternate channel selectivity ±400kHz	65dB
Capture ratio	1dB
Image rejection at 98MHz	40dB
IF rejection at 98MHz	70dB
Spurious response rejection at 98MHz	70dB
AM suppression	50dB
Stereo separation	
1 kHz	40dB
Carrier leak	
19kHz	-30dB (-35dB, IHF)
38kHz	-50dB(-55dB, IHF)
Channel balance (250Hz-6.3kHz)	±1.5dB
Limiting point	1.2μV
Bandwidth	
IF amplifier	180kHz
FM demodulator	1000kHz
Antenna terminal(s)	75Ω (unbalanced)

Technics®

© 1996 Matsushita Electronics (S) Pte. Ltd.
All rights reserved. Unauthorized copying and distribution is a violation of law.

⚠ WARNING

This service information is designed for experienced repair technicians only and is not designed for use by the general public. It does not contain warnings or cautions to advise non-technical individuals of potential dangers in attempting to service a product. Products powered by electricity should be serviced or repaired only by experienced professional technicians. Any attempt to service or repair the product or products dealt with in this service information by anyone else could result in serious injury or death.

■ AM Tuner Section

Frequency range	
MW	522 — 1611kHz (9kHz steps) 530 — 1620kHz (10kHz steps)
LW	144 — 288kHz
Sensitivity	
MW	20 μ V, 330 μ V/m
LW	45 μ V
Selectivity	
MW (at 999kHz)	55dB
LW (at 252kHz)	55dB
Image rejection	
MW (at 999kHz)	40dB
LW (at 252kHz)	40dB
IF rejection	
MW (at 999kHz)	55dB
LW (at 252kHz)	55dB

■ Contents

	PAGE
• PROTECTION CIRCUITRY.....	2
• BEFORE REPAIR AND ADJUSTMENT.....	2
• CAUTION FOR AC MAINS LEAD.....	3
• OPERATION CHECKS AND MAIN COMPONENT REPLACEMENT	4 ~ 8
• FAN MOTOR TROUBLESHOOTING.....	9
• TROUBLESHOOTING.....	10 ~ 13
• BLOCK DIAGRAM.....	14 ~ 17
• TERMINAL FUNCTIONS OF ICs.....	18

■ Protection Circuitry

The protection circuitry may have operated if either of the following conditions are noticed:

- No sound is heard when the power is turned on.
- Sound stops during a performance.

The function of this circuitry is to prevent circuitry damage if, for example, the positive and negative speaker connection wires are "shorted", or if speaker systems with an impedance less than the indicated rated impedance of the amplifier are used.

■ Before Repair and Adjustment

Disconnect AC power, discharge 4 Power Supply Capacitors C703, C704, C705 and C706 through a 10 Ω , 5W resistor to ground. DO NOT SHORT-CIRCUIT DIRECTLY (with a screwdriver blade, for instance), as this may destroy solid state devices. After repairs are completed, restore power gradually using a variac, to avoid overcurrent.

Current consumption at AC 230 V, 50Hz in NO SIGNAL mode should be 120 ~ 350 mA.

Current consumption at AC 240 V, 50Hz in NO SIGNAL mode should be 130 ~ 380 mA.

■ Video Section

Output voltage at 1 V input (unbalanced)	1 \pm 0.1 Vp-p
Maximum input voltage	1.5 Vp-p
Input/output impedance	75 Ω (unbalanced)

■ General

Power consumption	230W
Power supply	AC 230 — 240V, 50Hz
Dimensions (W x H x D)	430 x 136 x 358 mm
Weight	9.3 kg

Notes :

1. Specifications are subject to change without notice. Weight and dimensions are approximate.
2. Total harmonic distortion is measured by the digital spectrum analyzer.

	PAGE
• TERMINAL GUIDE OF ICs, TRANSISTORS & DIODES..	18 & 19
• SCHEMATIC DIAGRAM.....	19 ~ 34
• PRINTED CIRCUIT BOARD	35 ~ 42
• WIRE CONNECTION DIAGRAM.....	43
• CABINET PARTS LOCATION.....	44
• REPLACEMENT PARTS LIST.....	45 ~ 47
• RESISTORS & CAPACITORS.....	47 ~ 51
• PACKAGING.....	52

If this occurs, follow the procedure outlines below:

1. Turn off the power.
2. Determine the cause of the problem and correct it.
3. Turn on the power once again after one minute.

Note:

When the protection circuitry functions, the unit will not operate unless the power is first turned off and then on again.

■ Caution for AC Mains Lead

[For [EB] area.]

For your safety, please read the following text carefully.

This appliance is supplied with a moulded three pin mains plug for your safety and convenience.

A 5-ampere fuse is fitted in this plug.

Should the fuse need to be replaced please ensure that the replacement fuse has a rating of 5-ampere and that it is approved by ASTA or BSI to BS1362.

Check for the ASTA mark  or the BSI mark  on the body of the fuse.

If the plug contains a removable fuse cover you must ensure that it is refitted when the fuse is replaced.

If you lose the fuse cover, the plug must not be used until a replacement cover is obtained.

A replacement fuse cover can be purchased from your local dealer.

CAUTION !

IF THE FITTED MOULDED PLUG IS UNSUITABLE FOR THE SOCKET OUTLET IN YOUR HOME THEN THE FUSE SHOULD BE REMOVED AND THE PLUG CUT OFF AND DISPOSED OFF SAFELY.

THERE IS A DANGER OF SEVERE ELECTRICAL SHOCK IF THE CUT OFF PLUG IS INSERTED INTO ANY 13-AMPERE SOCKET.

If a new plug is to be fitted, please observe the wiring code as shown below.

If in any doubt please consult a qualified electrician.

IMPORTANT

The wires in this lead are coloured in accordance with the following code:

Blue: Neutral

Brown: Live

As the colours of the wires in the mains lead of this appliance may not correspond with the coloured markings identifying the terminals in your plug, proceed as follows:

The wire which is coloured BLUE must be connected to the terminal in the plug which is marked with the letter N or coloured BLACK.

The wire which is coloured BROWN must be connected to the terminal in the plug which is marked with the letter L or coloured RED.

Under no circumstances should either or these wires be connected to the earth terminal of the three pin plug, marked with the letter E or the Earth symbol .

Before use

Remove the connector cover as follows.

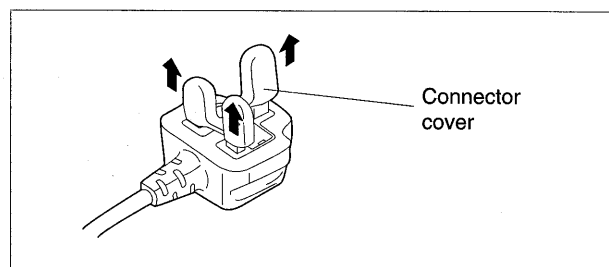

How to replace the fuse

1. Remove the fuse cover with a screwdriver.

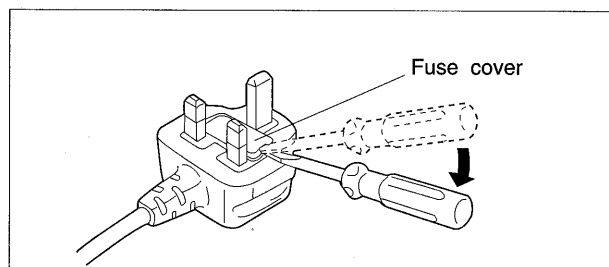

2. Replace the fuse and attach the fuse cover.

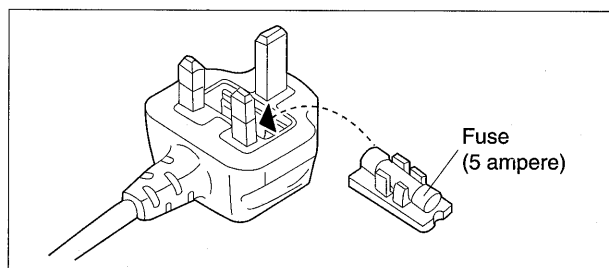

■ Operation Checks and Main Component Replacement Procedures

"ATTENTION SERVICER" Some chassis components may have sharp edges. Be careful when disassembling and servicing.

1. This section describes procedures for checking the operation of the major printed circuit boards and replacing the main components.
2. For reassembly after operation checks or replacement, reverse the respective procedures. Special reassembly procedures are described only when required.
3. Select items from the following index when checks or replacement are required.

• Contents

	page
• Checking Procedure For Each Major P.C.B.	4 ~ 6
• Main Component Replacement Procedures	6 ~ 8

■ Checking Procedure For Each Major P.C.B.

1. Checking of the Panel P.C.B., Pro Logic P.C.B. and Tuner P.C.B.

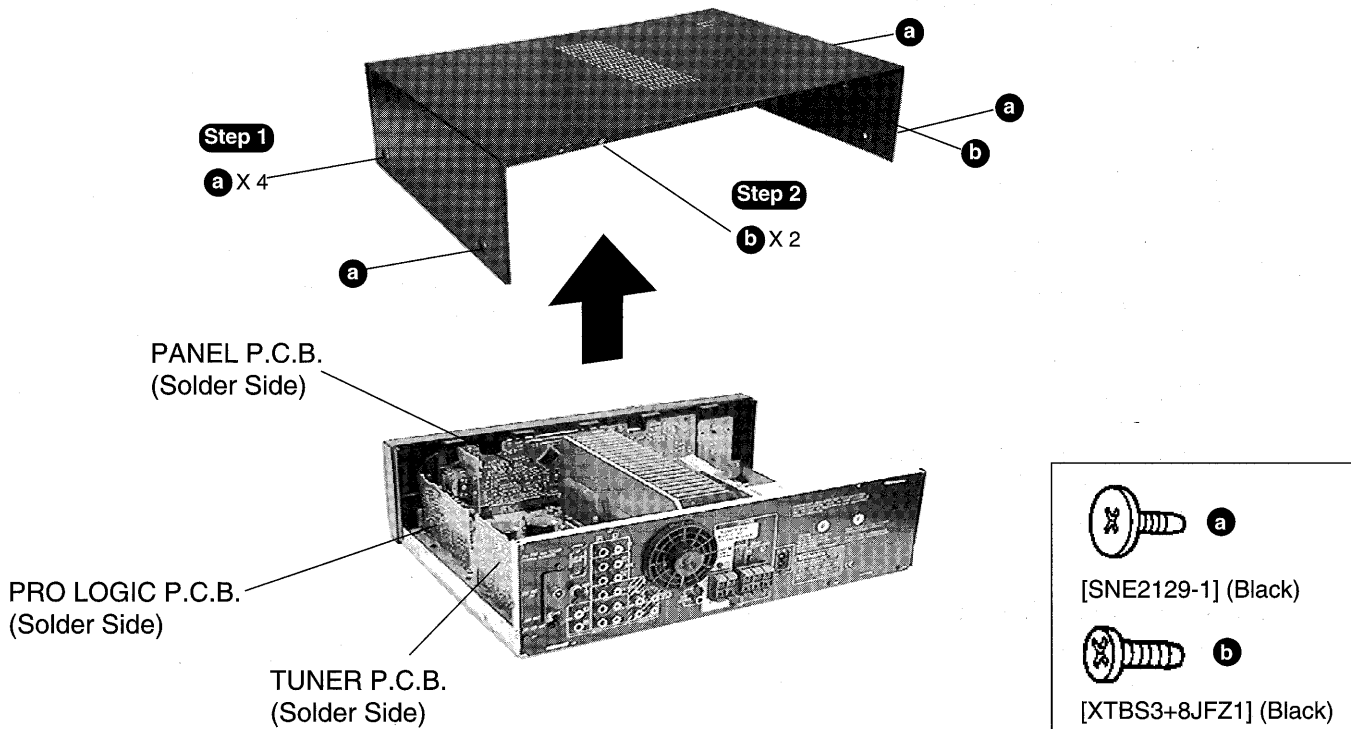

2. Checking of the IN/OUT TERMINAL P.C.B.

- Step 1**
Remove the top cabinet.
- Step 3**
Release the catch, pull the rear panel in the direction of arrow ① and simultaneously remove the tuner P.C.B. in the direction of arrow ②.

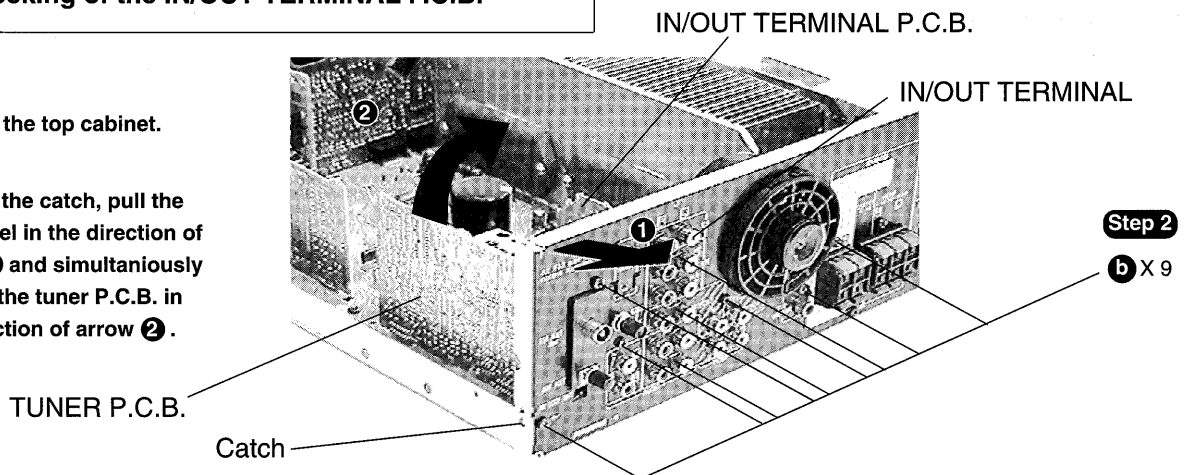

To Remove Front Panel, Panel P.C.B., Power Switch P.C.B. and Headphone Jack P.C.B.

Step 1
Remove the top cabinet.

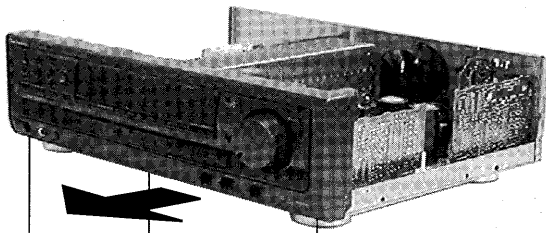

b X 3

Step 2

Step 3
Remove the front panel in the direction of arrow.

b

Power Switch P.C.B.

Headphone Jack P.C.B.

Step 4
Remove the Volume Knob and Nut.

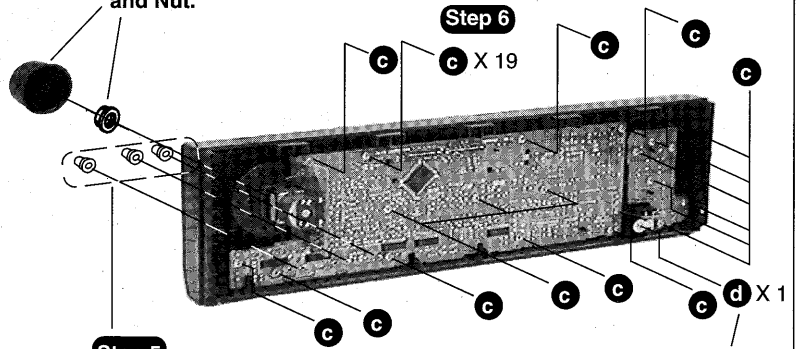

Step 6

c X 19

Step 5
Pull out 3 knobs.

Step 7

Panel P.C.B.

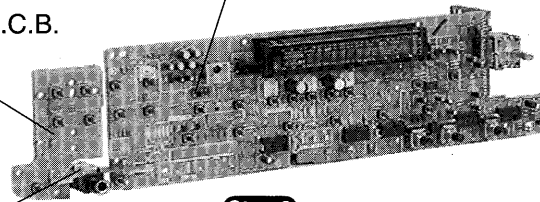

Step 8
Pull out the Headphone Jack P.C.B.



[XTBS26+10J]



[RHD26016]

3. Checking of the MAIN P.C.B.

Step 1
Remove the top cabinet.

Step 2
Remove the front panel.

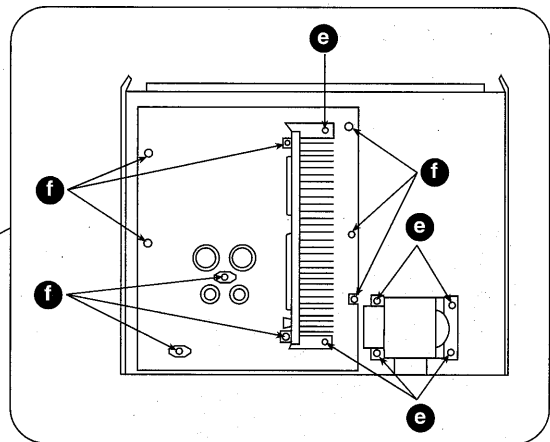

Step 4
e X 6

Step 3
f X 9

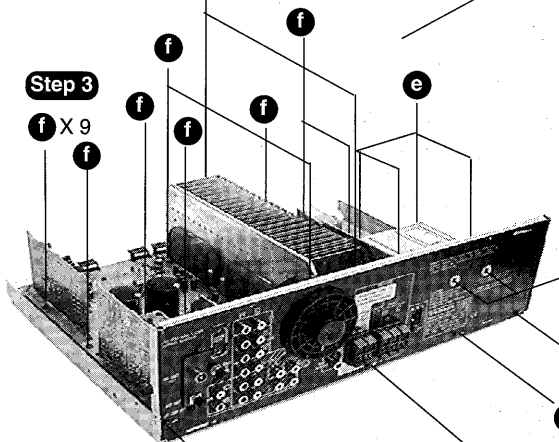

Step 5 **b X 4**

Step 8
Lift the rear panel in the direction of arrow ② and remove the bottom chassis in the direction of arrow ③.

Step 6
Replace screw from step 5 at the place indicated by .

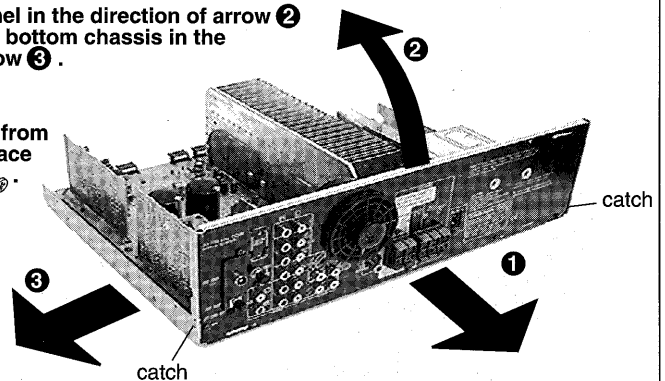

Step 7
Release 2 catches and pull the rear panel in the direction of arrow ① for about 10mm.
(Note : All P.C.B. and transformer are attach to the rear panel)

Step 8

Connect the front panel to the main P.C.B. as shown.



• Check the Main P.C.B. as shown •

MAIN P.C.B. (Solder Side)

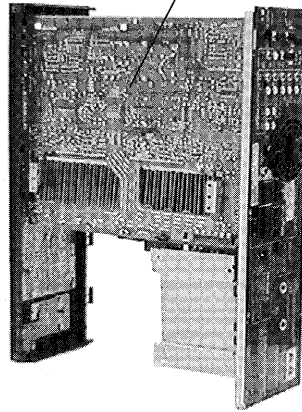

e

[XTB3+8FFZ] (Black)



f

[XTB3+20JFZ] (Black)

Main Component Replacement Procedures

1. Replacement of the Power IC and Regulator Transistor

Step 1

Remove the top cabinet.

Step 2 Cut the joints as shown below. (6 joints)

Locate the nipper to the thin portion of the joint.

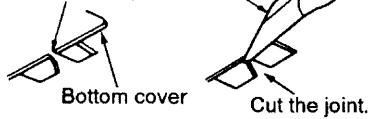

Bottom cover

Nipper

Cut the joint.

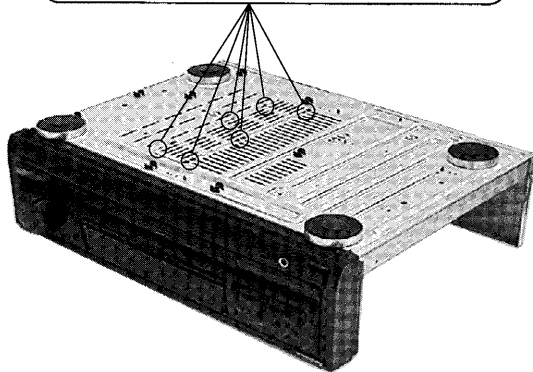

Step 3 Fold the joints. (6 joints)

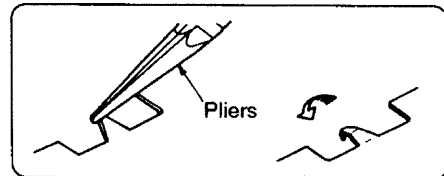

Pliers

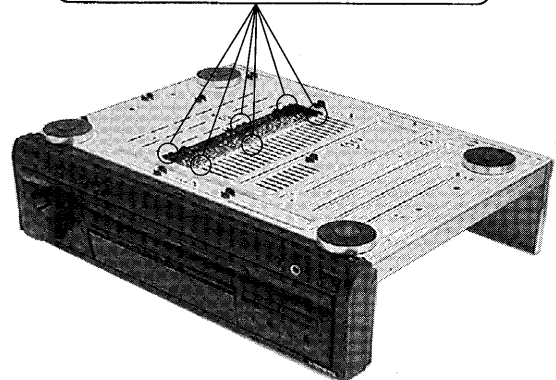

Step 4

Desolder the terminals of Power IC and Regulator Transistor.

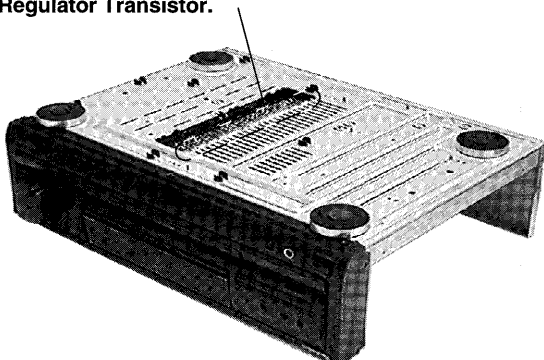

Power IC (IC602)
[RSN3305-P]

Power IC (IC601)
[RSN3305-P]

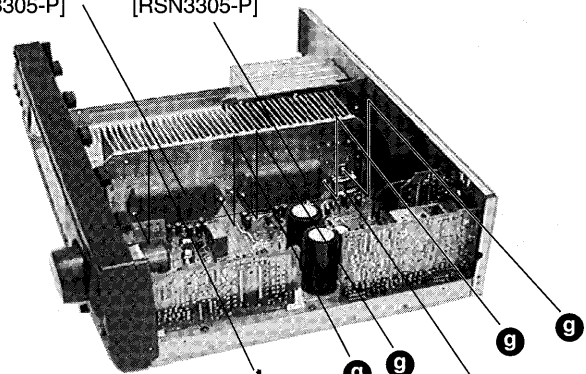

Step 5 g X 5

Regulator transistor
(Q701, Q708)

[2SD2374PQAU, 2SB1548PQAU]

Installation of the bottom cover after replacement

Step 1

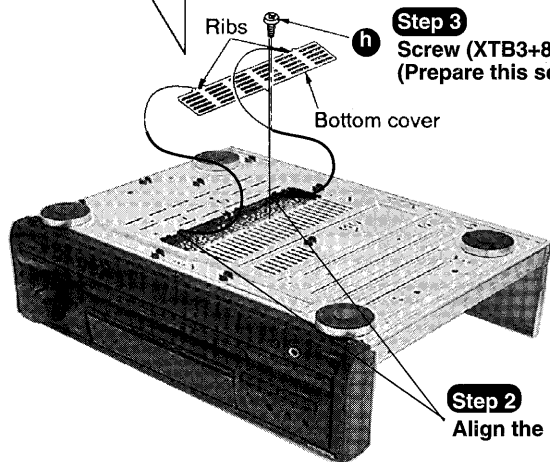
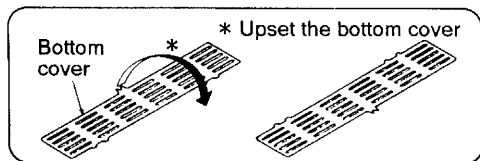

Step 3

Screw (XTB3+8J)
(Prepare this screw to fix the bottom cover.)



[XTW3+15T]



[XTB3+8J] (Black)

CAUTION

1. After replacing the power IC or regulator transistor, apply a sufficient quantity of compound grease (RFKX0002/SZZ0L15) between the heat sink and the power IC or regulator transistor (Radiation of power IC).
2. Tighten enough the screws (g) after replacing the power IC and regulator transistor. Otherwise, the heat radiation works little.
3. When installing or removing the power IC or transistor holder, be sure to use an offset screwdriver.

- A long straight screwdriver cannot be used for removing or mounting the screws since its long grip interferes with the neighbouring P.C.B. (See Fig.1)
- A short straight screwdriver may be used for removal, but cannot be used for mounting because the limited space in the unit will not allow sufficient tightening torque. (See Fig.2)

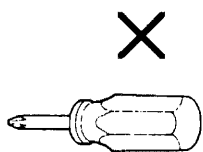

A short straight screwdriver

Fig.2

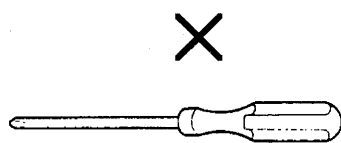

A short straight screwdriver

Fig.1

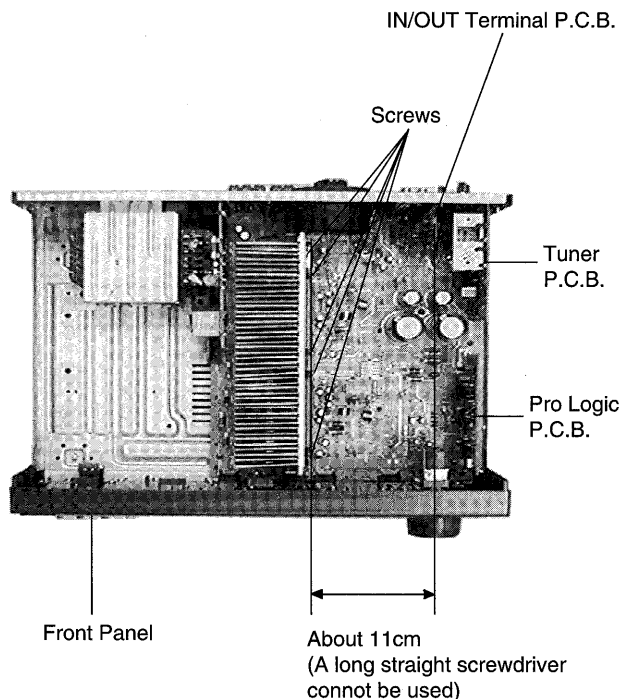

- Insufficient tightening will cause poor heat dissipation from the power IC and regulator transistor and, in the worst case, may lead to their thermal breakdown.

—OFFSET SCREWDRIVER—

•The PROTO offset screwdriver No.34-1/4 is recommended for use in the application above.

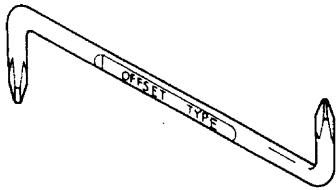

No.		
34 1/4	1 & 2	4 3/4"

•The address of PROTO International Sales is as follows.



International Sales

International Sales Office
Stanley-Proto Industrial Tools
14117 Industrial Park Blvd.
Covington, GA 30209 U.S.A.
Fax: 706-786-4387
Phone: 706-787-3800

Australia, New Zealand &
South Pacific
Stanley-Proto Industrial Tools
P.O.Box 10
400 Whitehorse Road
Nunawading 3131
Victoria, Australia
Fax: 61-3-894-1173
Phone: 61-3-878-9244

Singapore, Indonesia,
Philippines, Korea, Hong
Kong, Malaysia, China.
Stanley-Proto Asia Pacific
12 Gul Drive
Singapore 2262
Fax: 65-861-3206
Phone: 65-862-0883

Thailand
Stanley-Proto Thailand Ltd.
1017 Moo 13 Bangkaew
Amphur Bangplee
Samutprakarn, Thailand
Fax: 66-2-316-6071
Phone: 66-2-316-8655

Japan
Stanley Works Japan
2-7-16 Hyakunin-Cho
Shinjuku-ku
Tokyo 160 Japan
Fax: 81-3-3360-8456
Phone: 81-3-3360-8458

Mexico
Herramientas Stanley S.A.
DE C.V.
Apartado Postal 675
72030 Puebla, Pue, Mexico
Fax: 52-22-494-4880
Phone: 52-22-495-300

South & Central America,
Puerto Rico, The Caribbean
Stanley Inter-America
2101 N.W. 84th Ave.
Miami, Florida 33122
Fax: 305-594-4261
Phone: 305-591-3828

Europe
Stanley-Proto Europe
Woodside, Sheffield
S39PD
England
Fax: 44-742-739-038
Phone: 44-742-768-888

Canada
Stanley-Proto Canada
1100 Corporate Drive
Burlington, Ontario
Canada, L7L 5R6
Fax: 416-335-0075
Phone: 416-335-0075

Middel East, Mediterranean
& Africa
Stanley-MEMA
Cory House The Ring
Bracknell Berkshire
RG 12 1A2
England
Fax: 44-344-485-526
Phone: 44-344-51813

2. Replacement of the fan motor

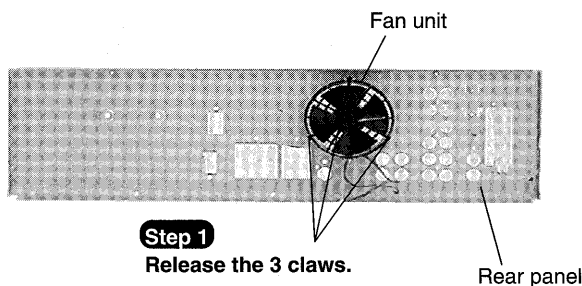

Step 1
Release the 3 claws.

NOTE

When replacing the fan motor, align the boss of the fan case with the hole of the fan motor.

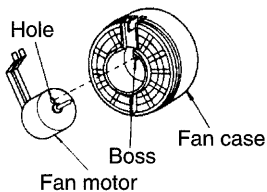

Step 2
Put a screwdriver at the root of the fan and remove it.

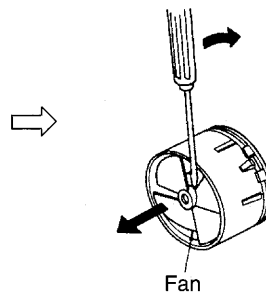

Step 3
Remove the fan cap.

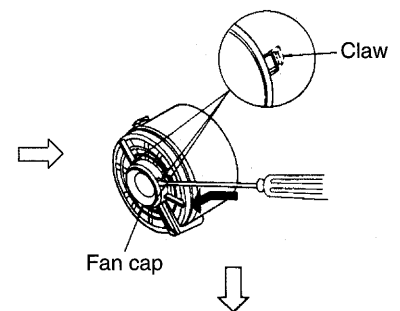

Step 4
Desolder the wires from the motor terminal and replace it with a new one.

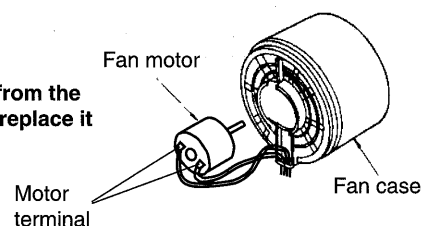

Fan Motor Troubleshooting

The Model SA-EX500 employ fan motor error sensing electronics.

If the cooling fan is not operating and "OVER LOAD" is displayed on the FL display, check the fan motor and its driving circuit.

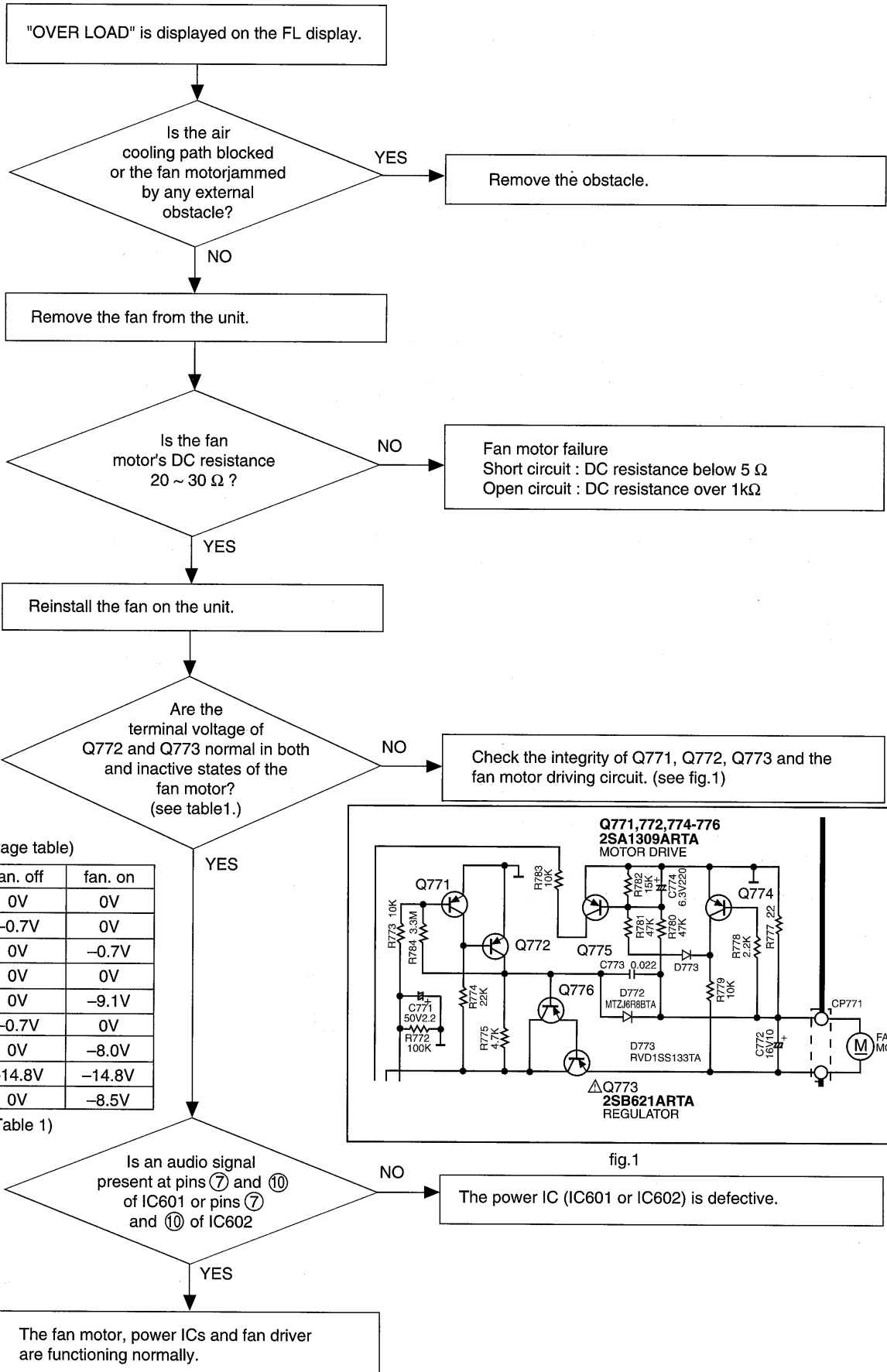

Troubleshooting

This unit has test points on each circuit board block for use in troubleshooting.

CONNECTION

Connect either a CD player, tape deck or AF oscillator to the input terminals of the unit.

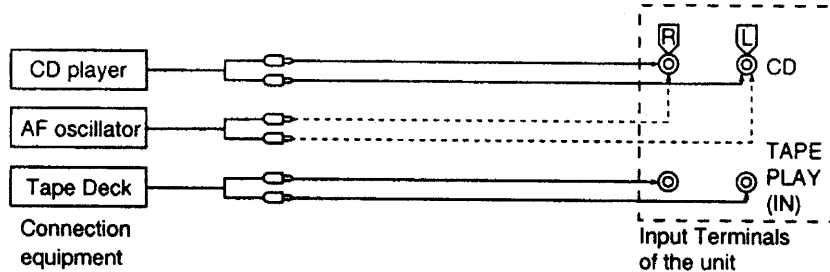

REQUIRED ITEMS

1. Testing with a CD player ——— Test disc (SZZP1054C / first program, 1kHz, 0dB)
2. Testing with a tape deck ——— Test tape (QZZCLA / 315Hz, 0dB)
3. Testing with a AF oscillator ——— Set the output at 500Hz, 200mV
4. Oscilloscope (min. 10MHz) ----- To measure the output waveform at the test points.



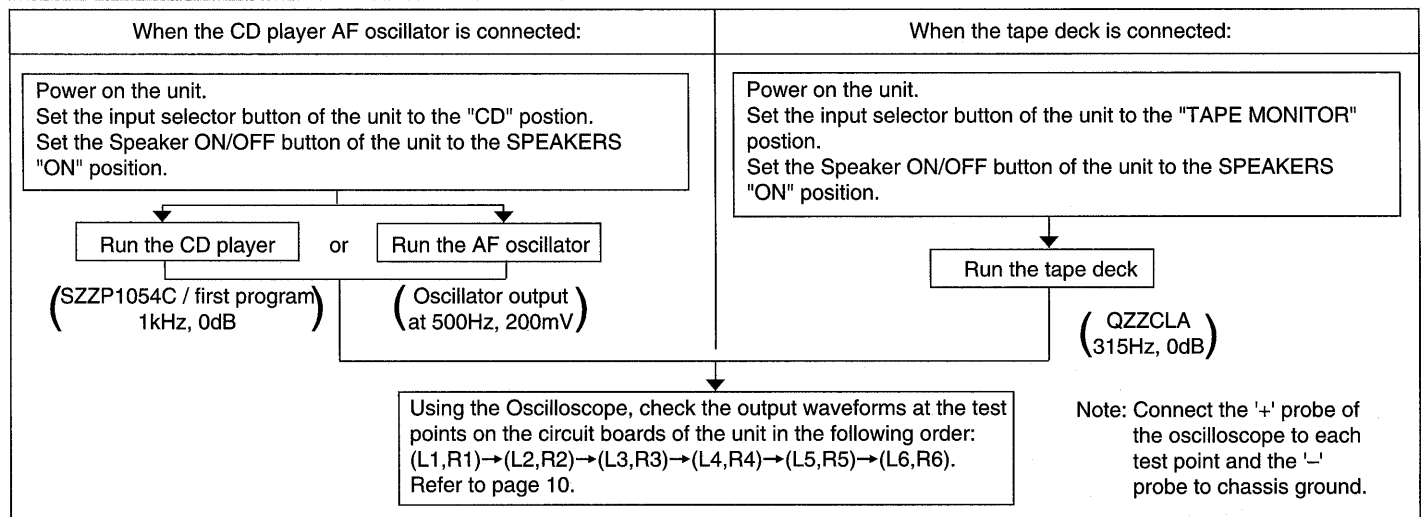



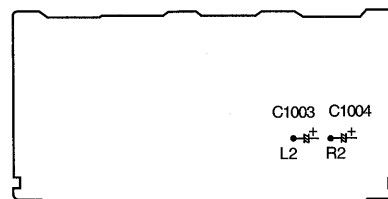
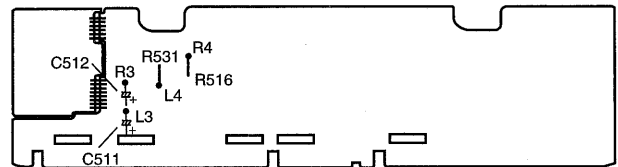
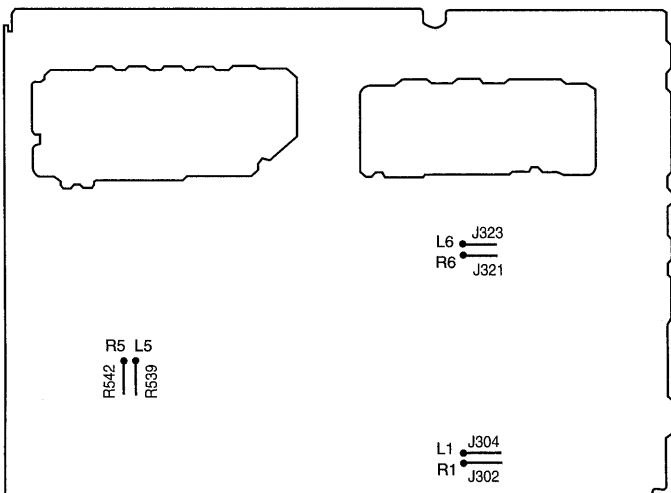

TEST PROCEDURE FOR AMPLIFIER CIRCUIT

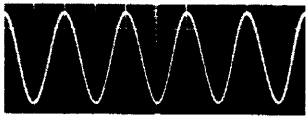
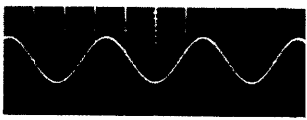

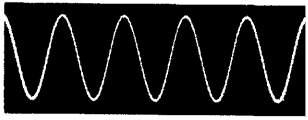
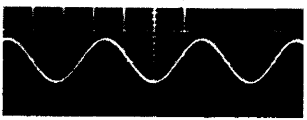

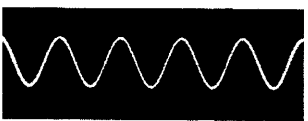
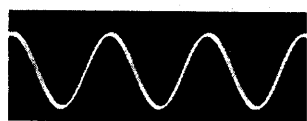
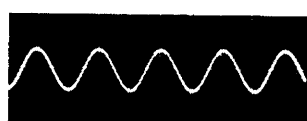
TEST POINTS POSITIONS OF AMPLIFIER CIRCUIT

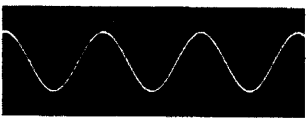

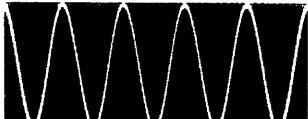
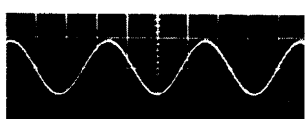
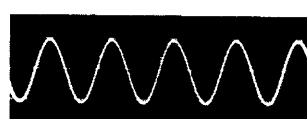
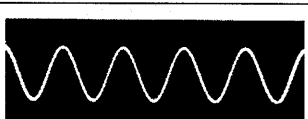
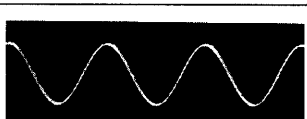
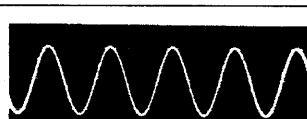
NORMAL WAVEFORMS OF AMPLIFIER CIRCUIT AND LIKELY FAULTY BLOCKS

TP	CD player	Tape deck	AF oscillator	Likely faulty block if the normal waveform shown at the left is not present.
L1/R1	 0.5msec 2V	 1msec 500mV	 1msec 500mV	Input selector block IC401 & area
L2/R2	 0.5msec 2V	 1msec 500mV	 1msec 500mV	Dolby pro logic block IC1001 and IC1002 & area
L3/R3	 0.5msec 500mV	 1msec 50mV	 1msec 100mV	Master volume block VR501 & area
L4/R4	 0.5msec 500mV	 1msec 1V	 1msec 1V	Tone control block IC511 & area
L5/R5	 0.5msec 100mV*	 1msec 500mV	 1msec 500mV	Power limiter block Q581 to Q584 & area
L6/R6	 0.5msec 5V*	 1msec 10V	 1msec 10V	Main amplifier block IC601 & area

Measurement conditions. Volume control (VR501), Treble control (VR512) and Bass control (VR511) positions: 
*Volume control position (VR501) for these test 

CHECKING PROCEDURE FOR SURROUND CIRCUIT

Outputting surround signal normally requires that opposite phase signals be applied to both the left and right channels. However, this unit incorporates a service mode, allowing the surround circuit to be tested using in-phase signals.

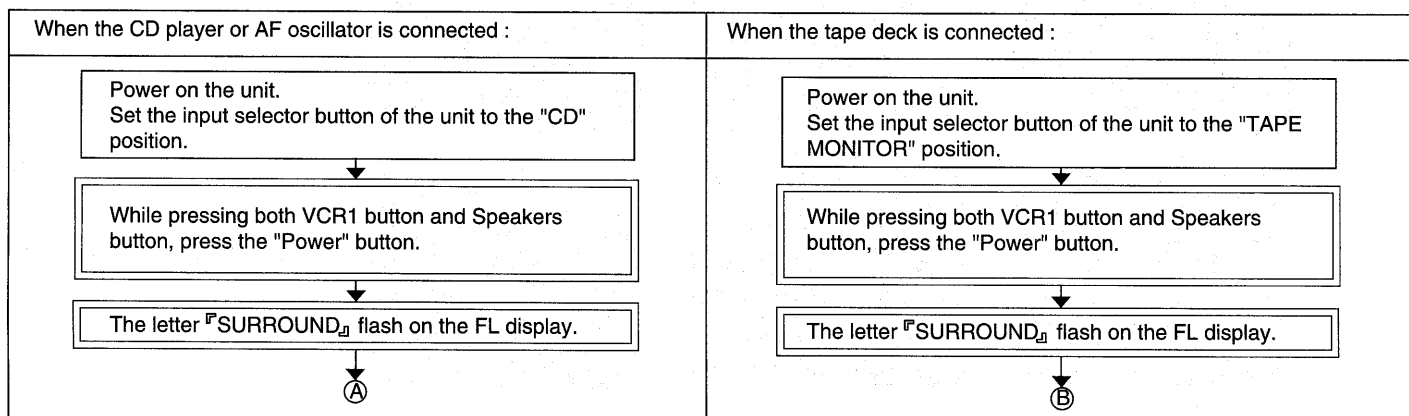

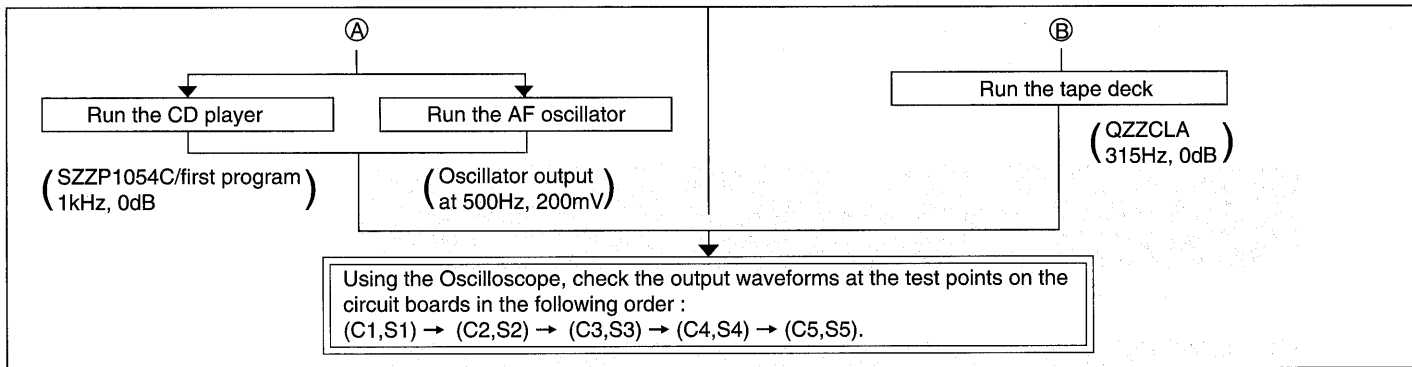

• To exit the service mode, power off the unit.

TEST POINTS POSITIONS OF SOURROUND CIRCUIT

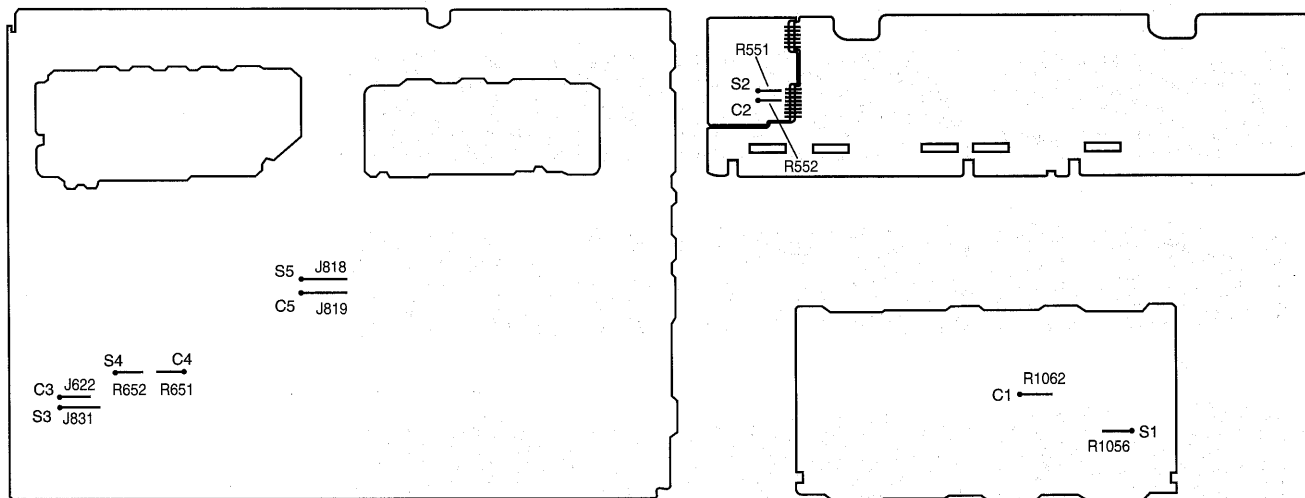

NORMAL WAVEFORMS OF AMPLIFIER CIRCUIT AND LIKELY FAULTY BLOCKS

TP	CD player	Tape deck	AF oscillator	Likely faulty block if the normal waveform shown at the left is not present.
C1 S1	 0.5msec 1V	 1msec 100mV	 1msec 200mV	Dolby pro logic block IC1001 and IC1002 & area
C2 S2	 0.5msec 200mV	 1msec 20mV	 1msec 50mV	Master volume block VR501 & area
C3 S3	 0.5msec 5V	 1msec 500mV	 1msec 1V	Tone control block IC551 & area

NORMAL WAVEFORMS OF AMPLIFIER CIRCUIT AND LIKELY FAULTY BLOCKS

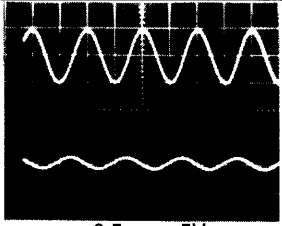
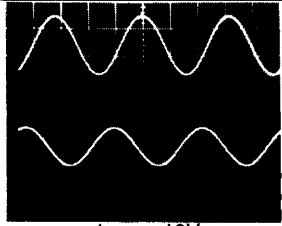
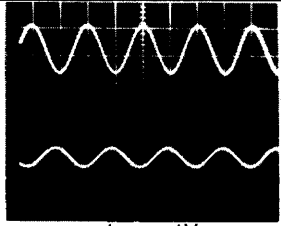
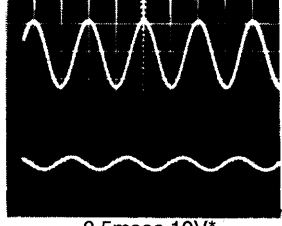
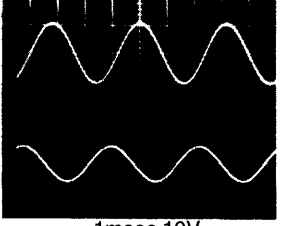
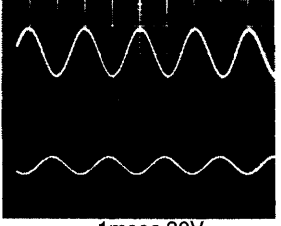
TP	CD player	Tape deck	AF oscillator	Likely faulty block if the normal waveform shown at the left is not present.
C4 S4	 0.5msec 5V	 1msec 10V	 1msec 1V	AF mute block Q551, Q552 & area
C5 S5	 0.5msec 10V*	 1msec 10V	 1msec 20V	Main amplifier block IC602 & area

Measurement conditions. Volume control (VR501), Tremble control (VR512) and Bass control (VR511) positions: ●
 *Volume control position (VR501) for these test : ○

CIRCUIT BLOCKS

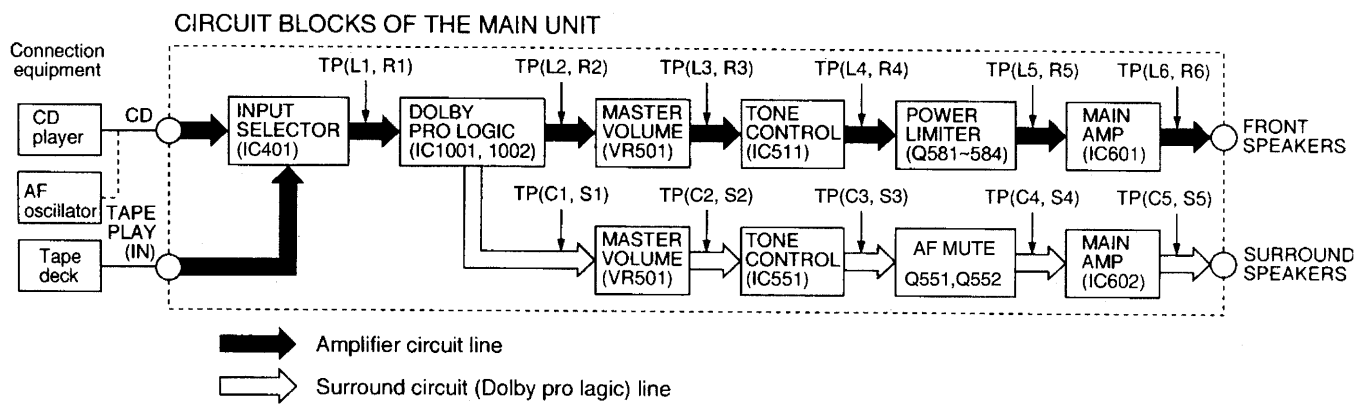

OVERLOAD DETECTION FUNCTION

The HIC protection circuit functions if any cord at a speaker terminal is short-circuited or if the unit overheats because of improper operation. At the same time, "OVERLOAD" scrolls across the FL display.
 In this state, all keys remain in operative; if any key is pressed, "SWITCH OFF POWER" scrolls across the FL display.
 If an overload occurs, immediately power off the unit and check the speaker connection, venting holes and cooling fans. After fixing any faults, power on the unit again and check for proper operation.
 If no defects are found, or if the unit remains overload after it is power on again, check the circuit for faults.

Block Diagram

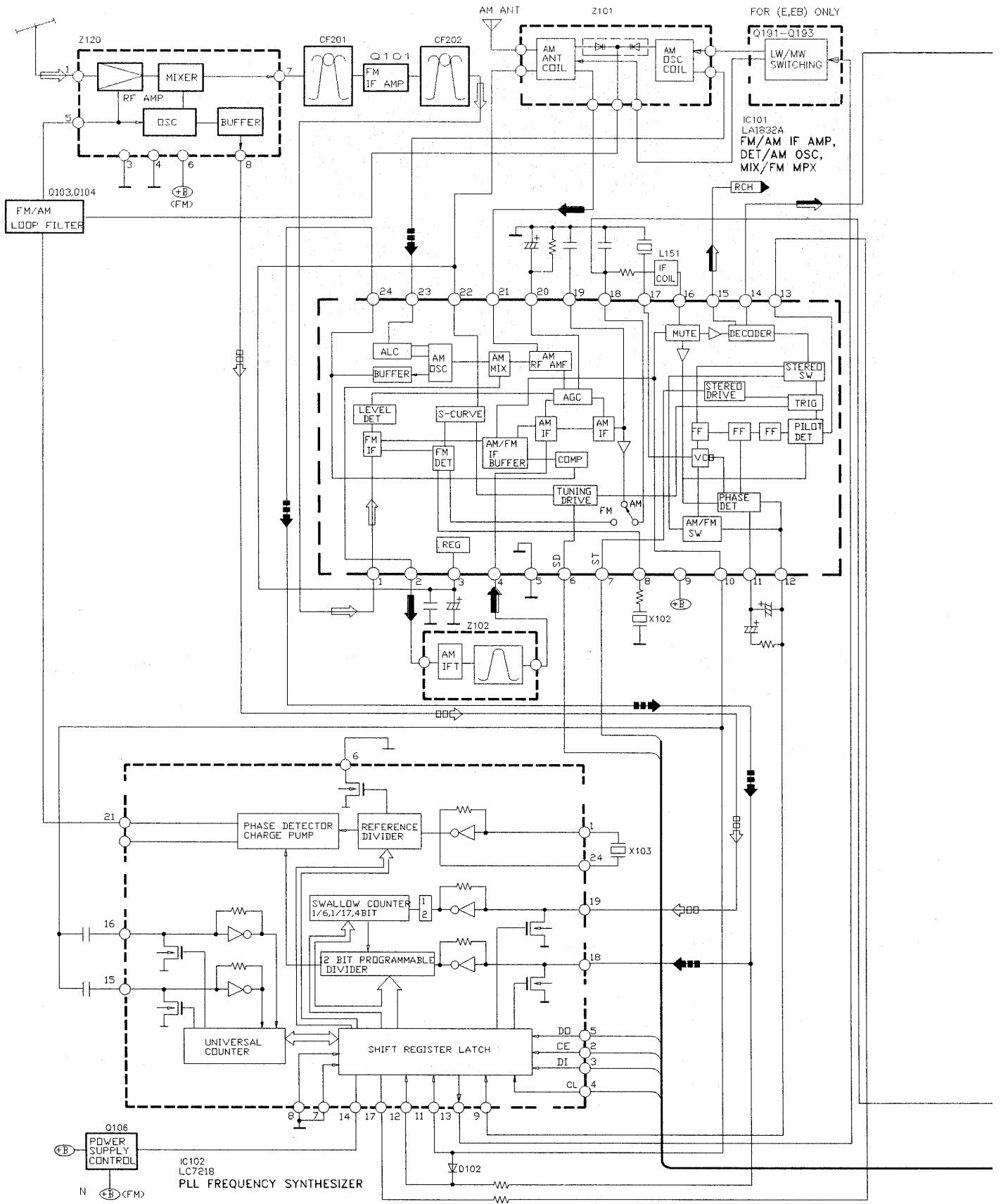

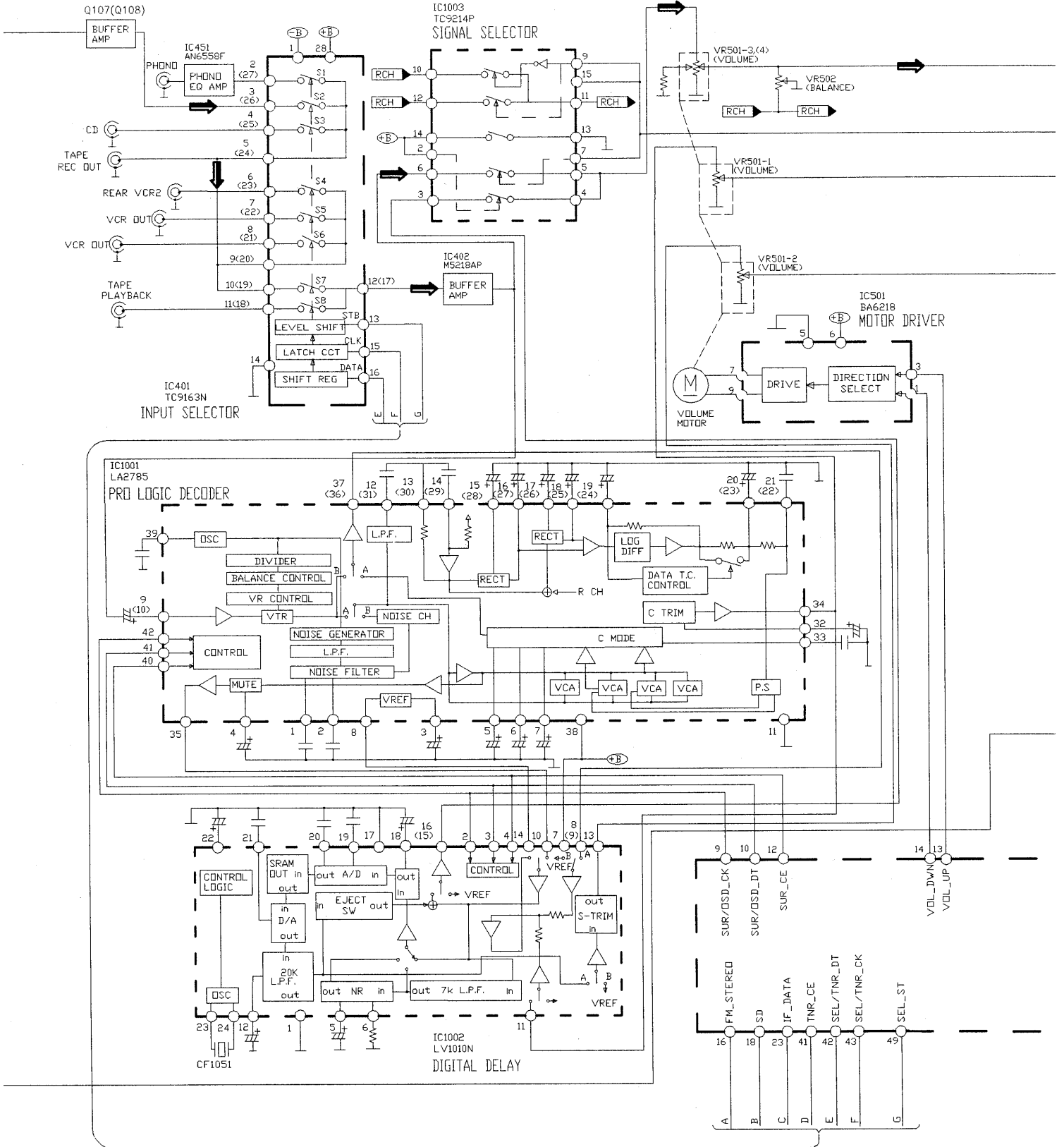

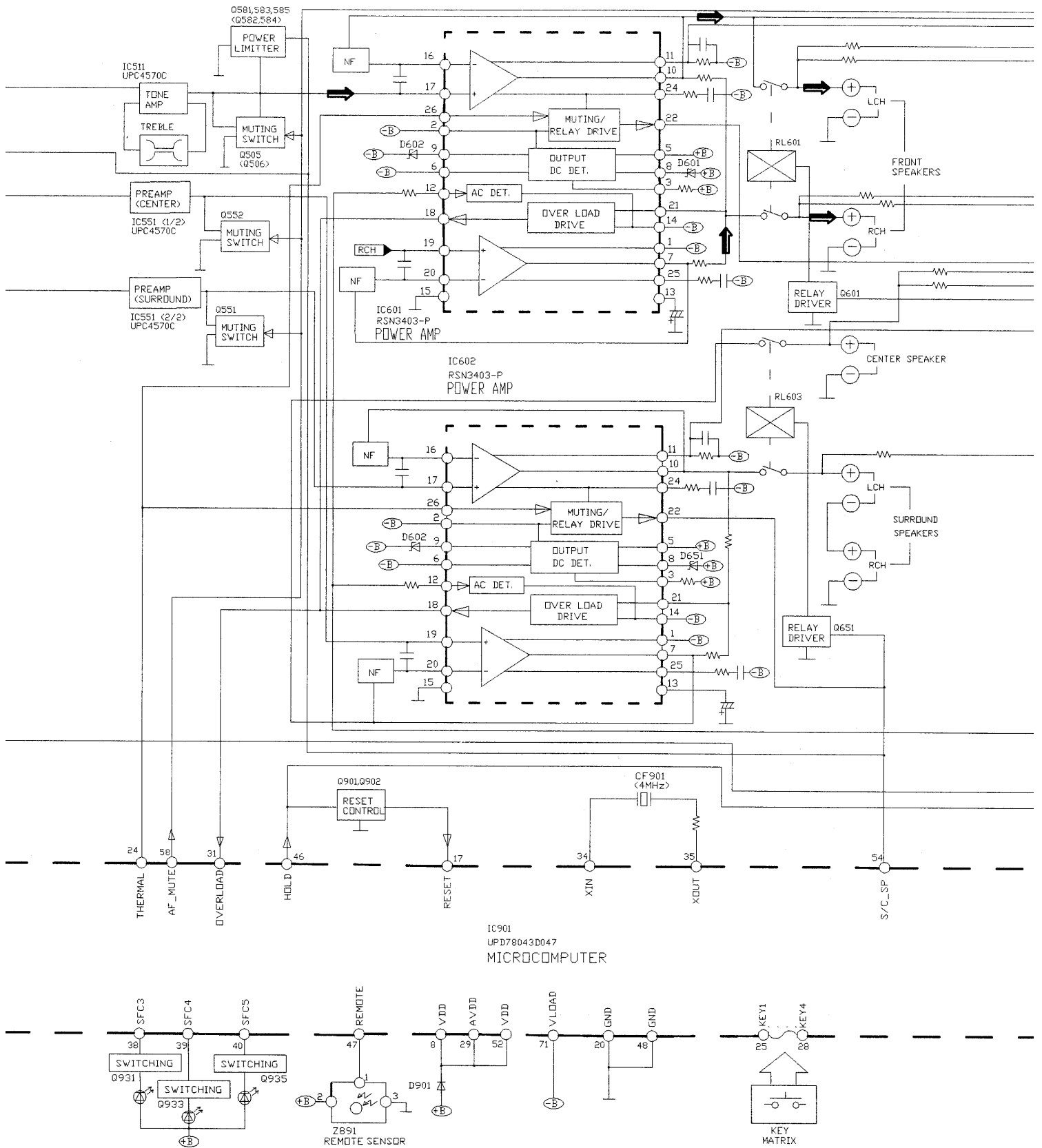

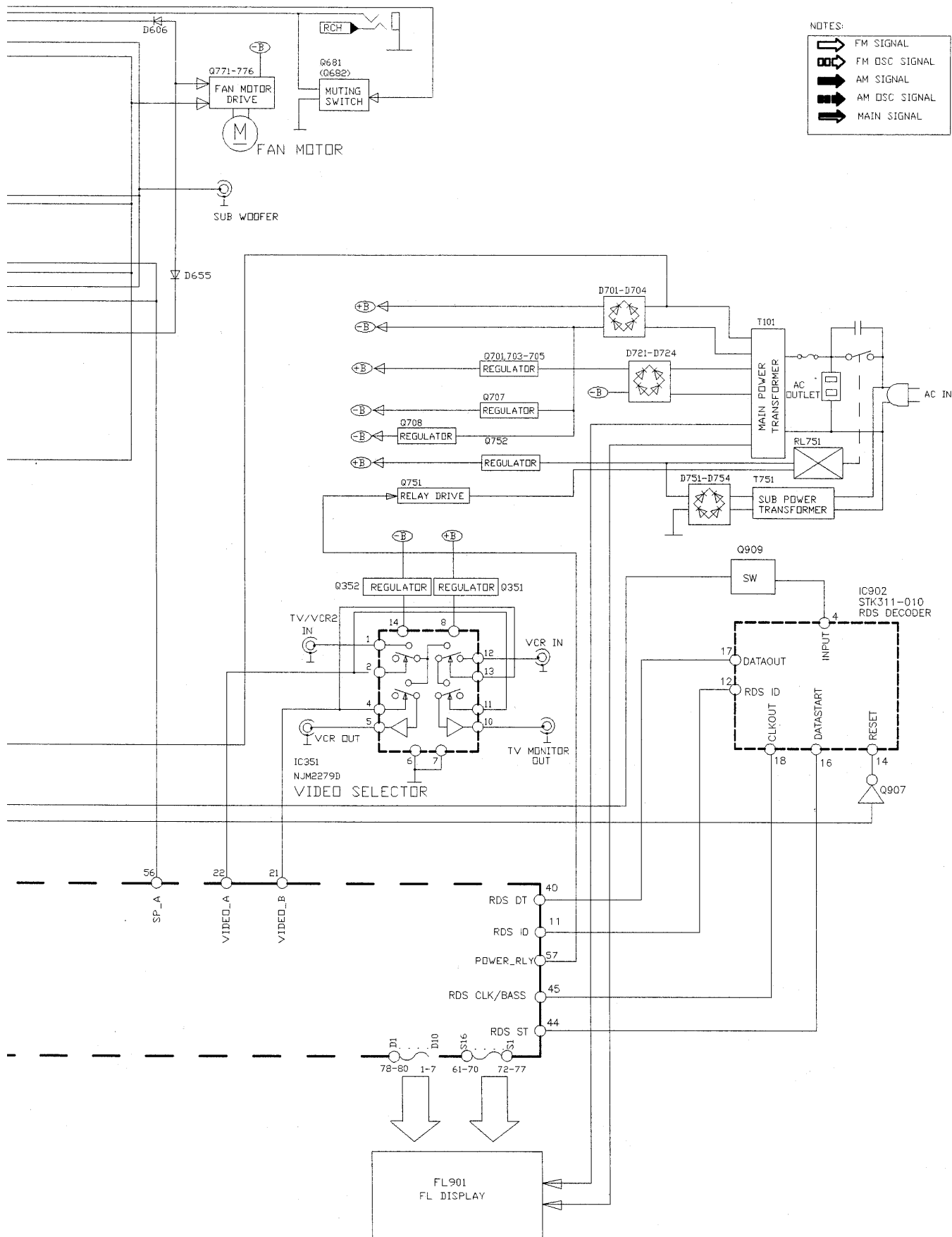

Terminal Functions Of ICs

• IC901 (UPD78043A047) System Microprocessor

Pin No.	Mark	I/O	Function
1-7	D4~D10	O	Digit signal of FL display
8	VDD	I	Power supply terminal
9	SUR/OSD_CK	O	Serial clock signal
10	SUR/OSD_DT	O	Serial data signal
11	RDS_ID	I	RDS ID signal input
12	SUR_CE	O	Chip enable signal
13	VOL_UP	O	Rotate control terminal of
14	VOL_DWN	O	volume motor
15	LOUDNESS	O	Loudness control terminal
16	FM_STEREO	I	Stereo signal detect terminal
17	RESET	I	Reset detect terminal
18	SD	I	Received signal detect terminal
19	OSD_ST	-	Not used
20	GND	-	GND terminal
21	VIDEO_B	O	Video selector control terminal
22	VIDEO_A	O	
23	IF_DATA	I	Serial data signal
24	THERMAL	O	Mute control terminal
25-28	KEY1~KEY4	I	Key matrix detect terminal
29	AVDD	I	Power supply terminal
30	AVREF	I	Power supply terminal
31	OVERLOAD	I	Over load detect terminal
32	XT2	-	Not used
33	GND	-	GND terminal
34	XIN	I	Crystal oscillator terminal
35	XOUT	O	(4MHz)
36-38	SFC1~SFC3	-	Not used

Pin No.	Mark	I/O	Function
39	TV/VCR2	-	Not used
40	RDS_DT	I	RDS data input
41	TNR_CE	O	Chip enable signal
42	SEL/TNR_DT	O	Serial data signal
43	SEL/TNR_CK	O	Serial clock signal
44	RDS_ST	I	RDS data start signal input
45	RDS_CK	I	RDS clock input
46	HOLD	I	Hold signal input terminal
47	REMOTE	I	Remote control terminal
48	GND	-	GND terminal
49	SEL_ST	O	Level shift control terminal
50	HELP_LED	O	LED drive signal(HELP)
51	STANDBY_LED	-	Not used
52	VDD	I	Power supply terminal
53	REC_MUTE	-	Not used
54	S/C_SP	O	Surround and speaker select control terminal
55	SP_B	-	Not used
56	SP_A	O	Speaker select control terminal
57	POWER_RLY	O	Relay control terminal
58	AF_MUTE	O	Muting control terminal
59	LIMITTER	-	Not used
60	INIT_IN	-	Not used, connect to resistor
61-70	S16~S7	O	Segment signal of FL display
71	VLOAD	I	Power supply terminal
72-77	S6~S1	O	Segment signal of FL display
78-80	D1~D3	O	Digit signal of FL display

Terminal Guide of ICs, Transistors and Diodes

<p>LA1832A LC7218</p>	<p>NJM2279D</p>	<p>TC9163N 28Pin</p>	<p>M5218AP</p>	<p>AN6558-F UPC4570C</p>	<p>BA6218</p>
<p>RSN3305-P</p>	<p>UPD78043A047 80 Pin</p>	<p>LA2785</p>	<p>LV1010N</p>	<p>TC9214P</p>	<p>STK311-010</p>
<p>2SC3940AQSTA 2SB621ARTA 2SD592ARTA</p>	<p>RVTDTTC144YST 2SA933SSTA</p>	<p>2SB1548PQAU 2SD2374PQAU</p>		<p>2SC2785FETA 2SC2787LTA 2SA1309ARTA 2SC3311ARTA 2SD1915FTA UN411FTA UN421FTA UN4119TA</p>	<p>1N5402BM21 SB360L6508</p>

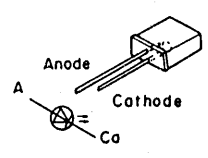
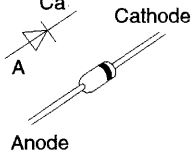
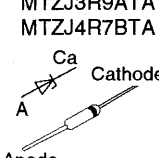
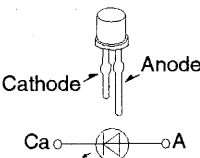
<p>LN846RPH</p> 	<p>RVD1SS133TA 1SR35200TB MA700ATA 1SS291TA MA167ATA MA165TA MA723TA</p> 	<p>MTZJ10CTA MTZJ3R9ATA MTZJ4R7BTA</p> 	<p>MTZJ6R2BTA MTZJ6R8BTA MTZJ7R5CTA MTZJ5R1BTA MTZJ5R6BTA MTZJ3R0ATA MTZJ24DTA MTZJ15CTA</p>	<p>LN41YCPHL</p> 
--	--	--	--	--

■ Schematic Diagram

(All schematic diagrams may be modified at any time with the development of new technology)

Note :

• S946	:	Power switch	• S963	:	TV/VCR2 select switch
• S947	:	Phono select switch	• S964	:	VCR1 select switch
• S948	:	Muting switch	• S970	:	Simulated switch
• S950	:	FM Auto/ Mono switch	• S971	:	Theater switch
• S951	:	Band select switch	• S972	:	Live switch
• S952	:	Tuning decrease switch	• S973	:	Club switch
• S953	:	Tuning increase switch	• S974	:	Hall switch
• S954	:	Memory manual/auto switch	• S980	:	Speakers on/off switch
• S955	:	Sleep switch	• S983	:	Dolby Pro Logic/SFC off on switch
• S956	:	Preset decrease switch	• S984	:	Dolby Pro Logic mode select switch
• S957	:	Preset increase switch	• S985	:	Center mode select switch
• S958	:	Help switch	• VR501-1 ~ VR501-4	:	Volume control
• S960	:	Tuner select switch	• VR502	:	Balance control
• S961	:	CD select switch	• VR511-1 ~ VR511-2	:	Bass control
• S962	:	Tape select switch	• VR512-1 ~ VR512-2	:	Treble control

• Signal line

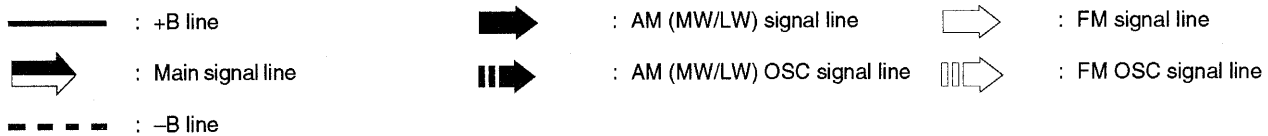

•The voltage value and waveforms are the reference voltage of this unit measured by DC electronic voltmeter (high impedance) and oscilloscope on the basis of chassis. Accordingly, there may arise some error in voltage values and waveforms depending upon the internal impedance of the tester or the measuring unit.

() AM(MW/LW) < > FM

•Importance safety notice:

Components identified by  mark have special characteristics important for safety. Furthermore, special parts which have purposes of fire-retardant (resistors), high-quality sound (capacitors), low-noise (resistors), etc. are used. When replacing any of components, be sure to use only manufacturer's specified parts shown in the parts list.

Caution !

- IC, LSI and VLSI are sensitive to static electricity.
- Secondary trouble can be prevented by taking care during repair.
- Cover the parts boxes made of plastics with aluminium foil.
- Ground the soldering iron.
- Do not touch the pins of IC, LSI or VLSI with fingers directly.
- Put a conductive mat on the work table.

J POWER SUPPLY CIRCUIT

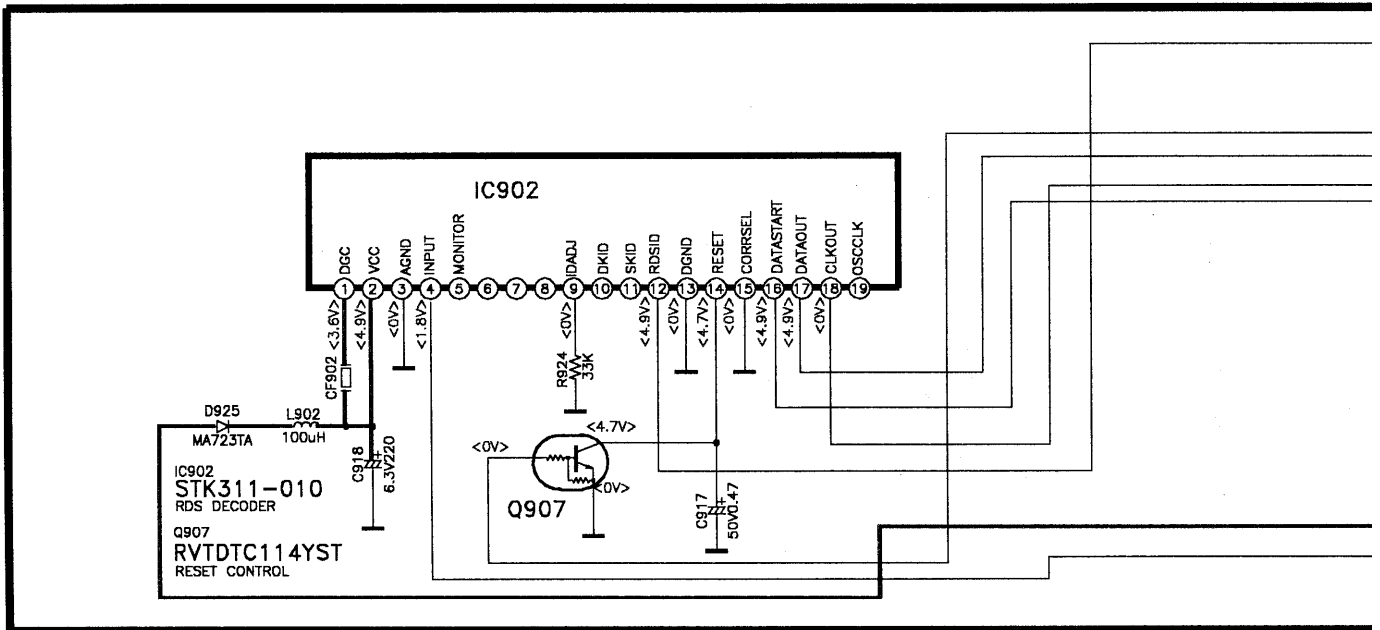
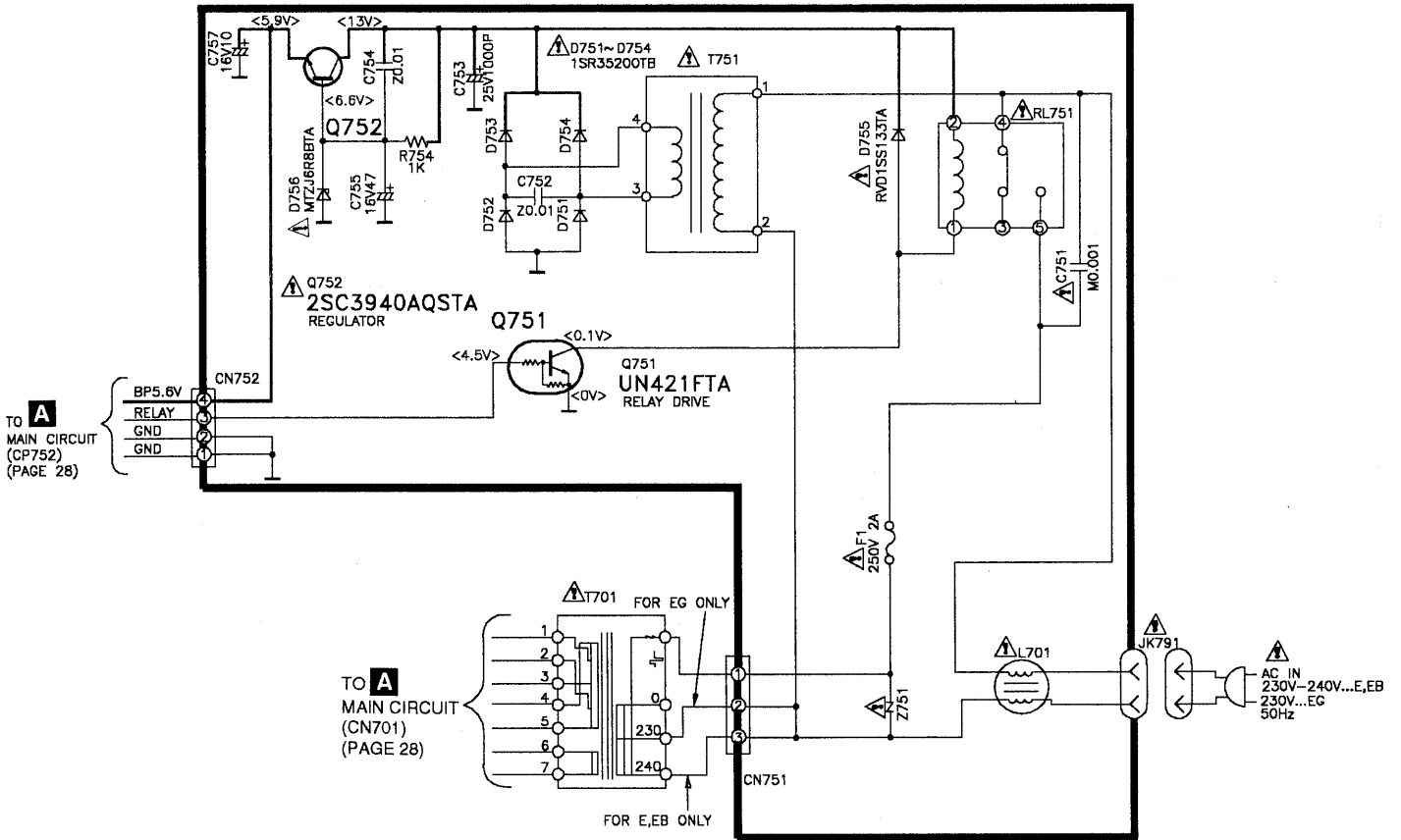

B PANEL CIRCUIT

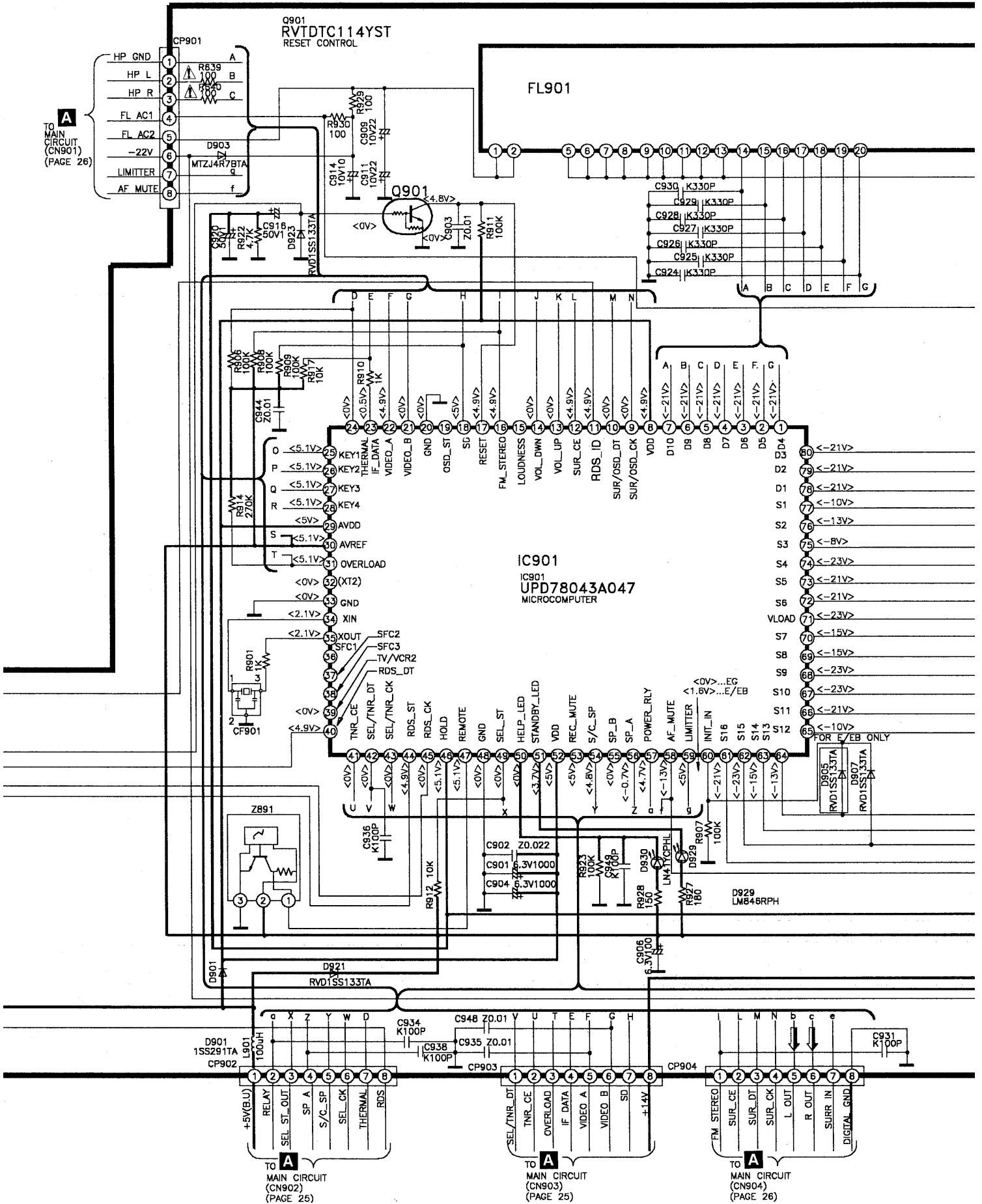

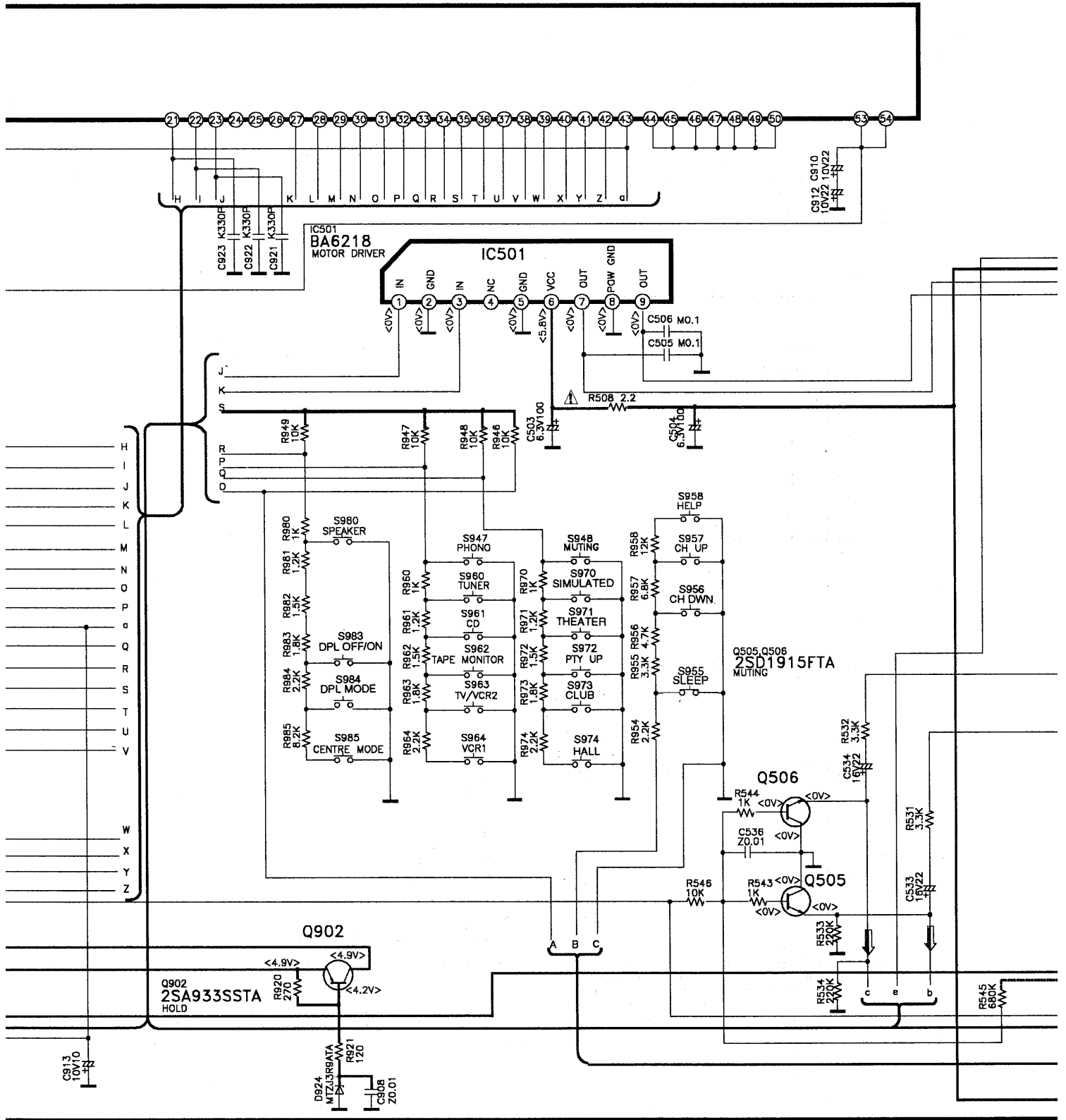

C MOTOR CIRCUIT

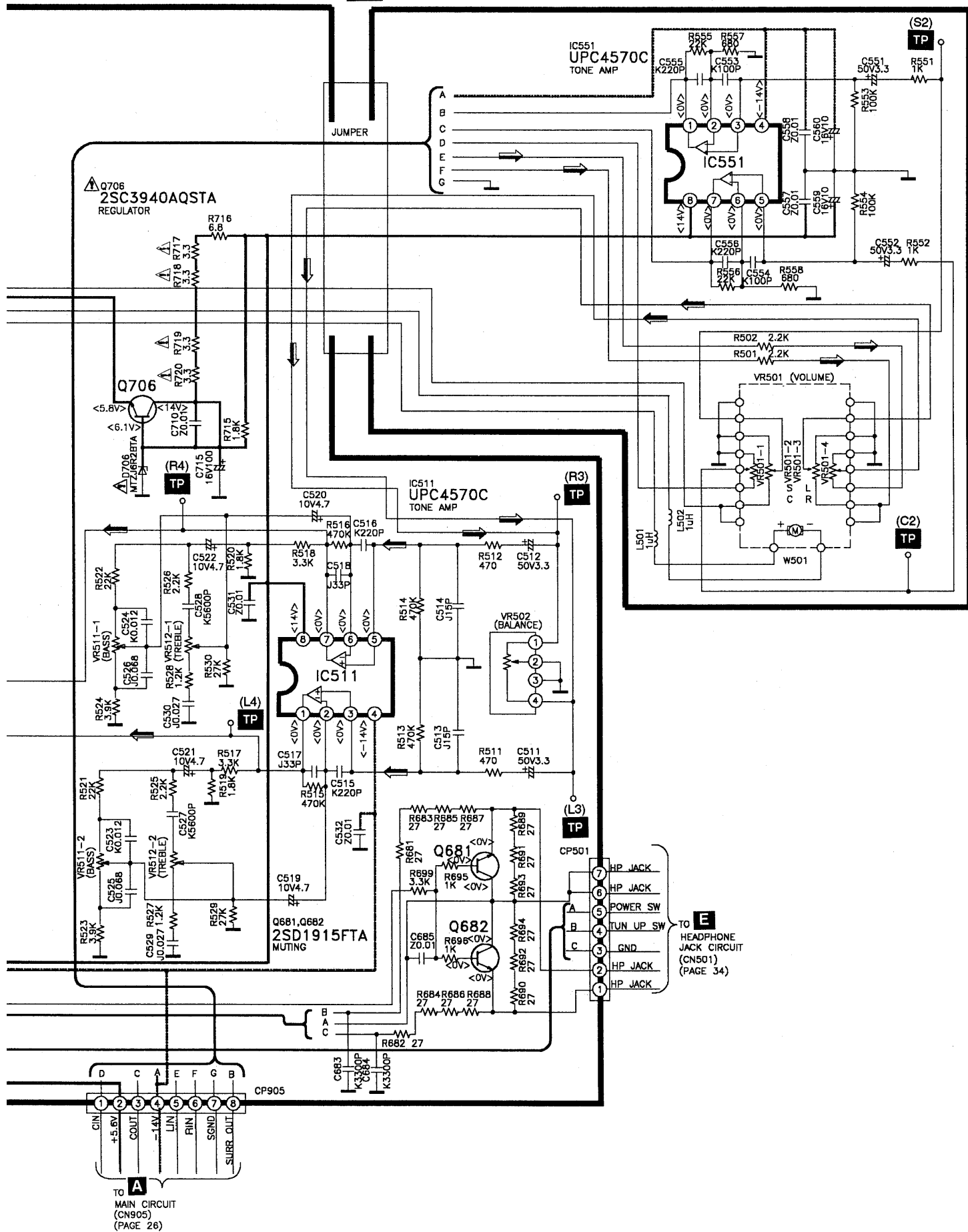

A MAIN CIRCUIT

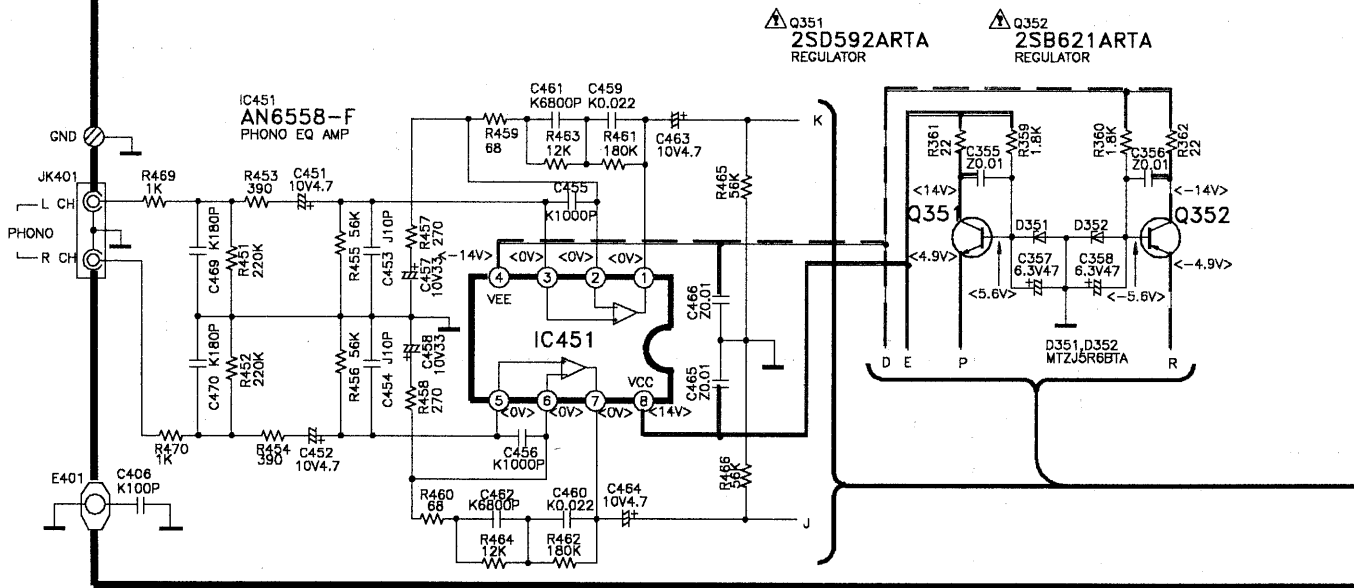

H IN/OUT TERMINAL CIRCUIT

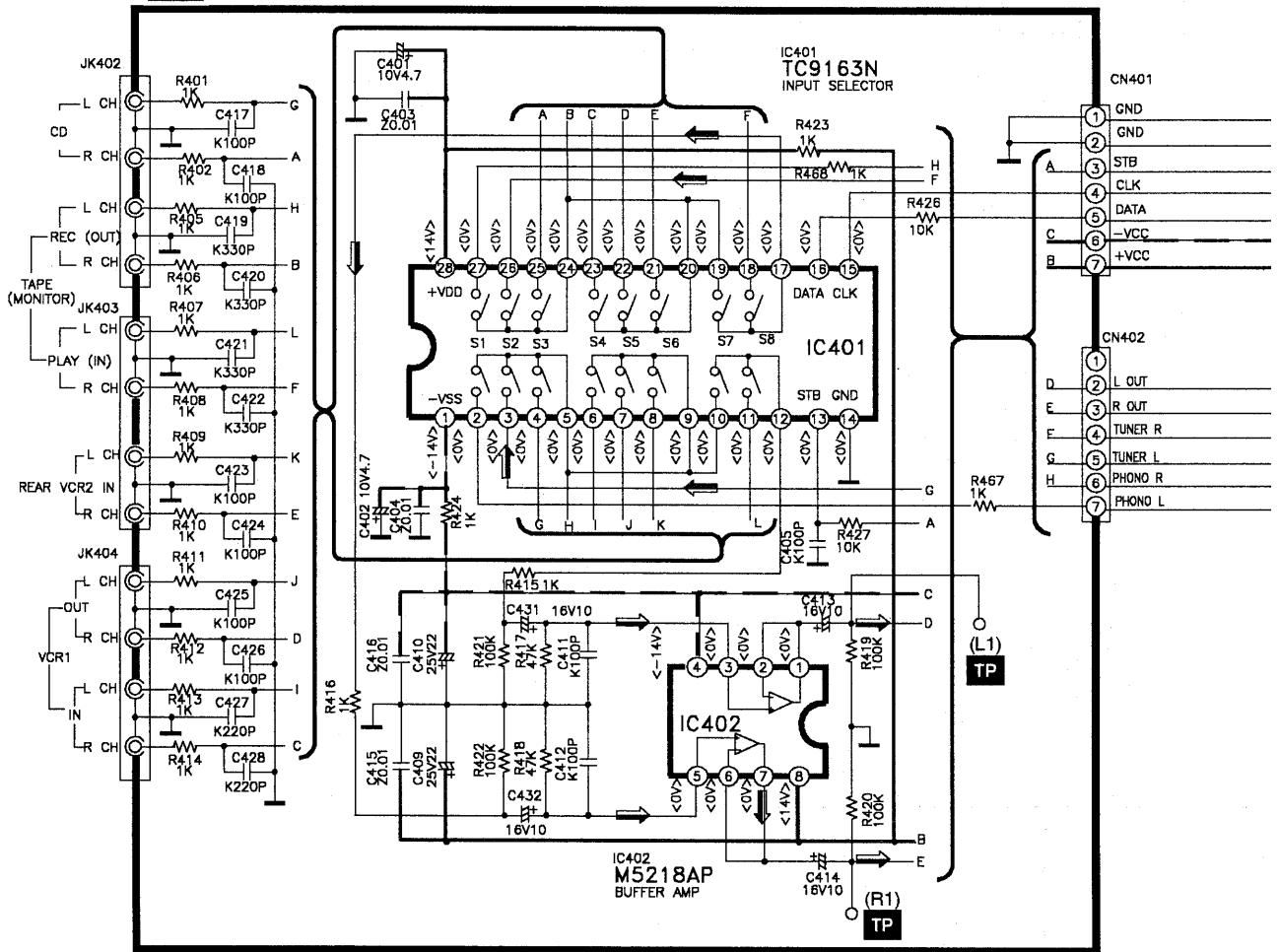

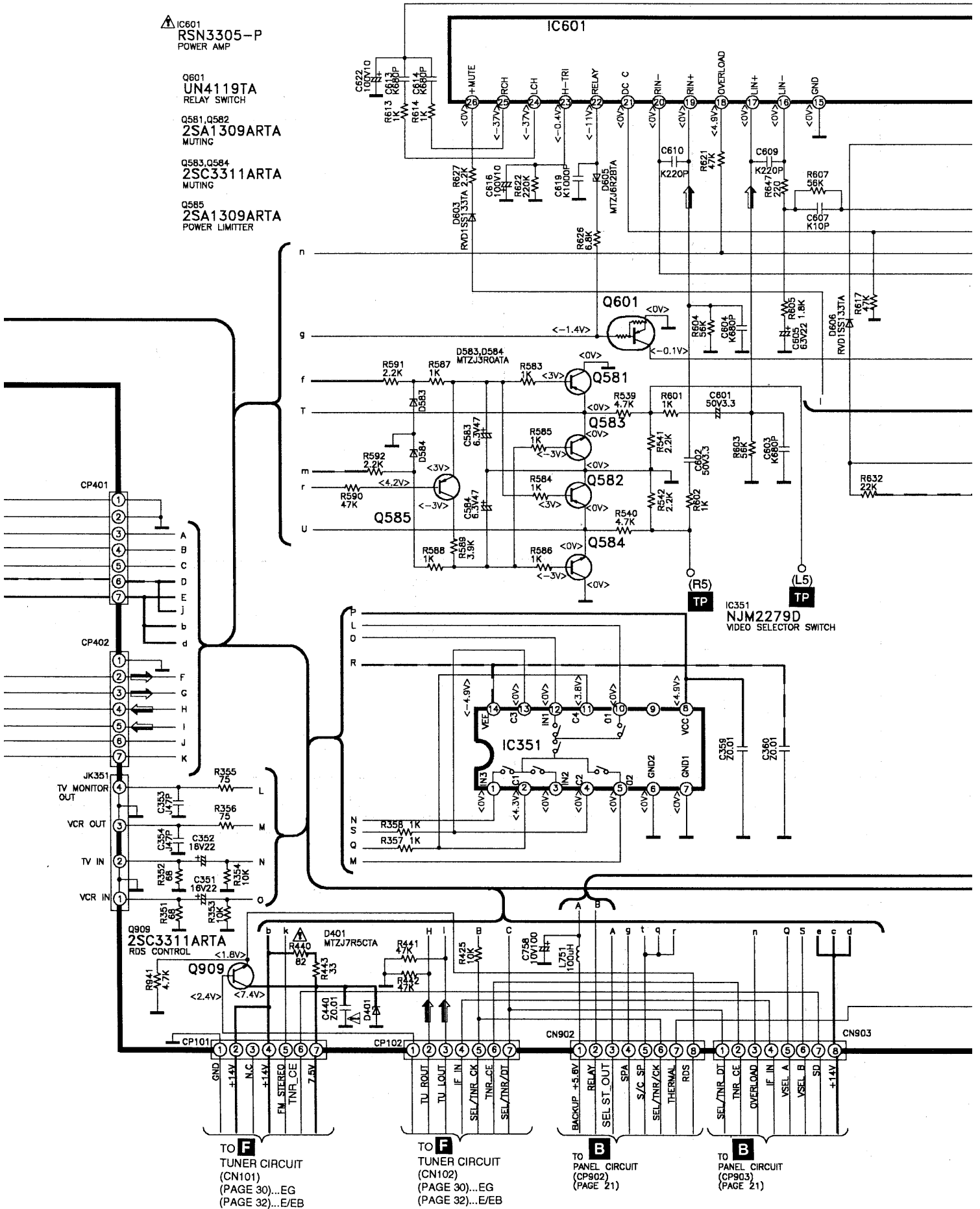

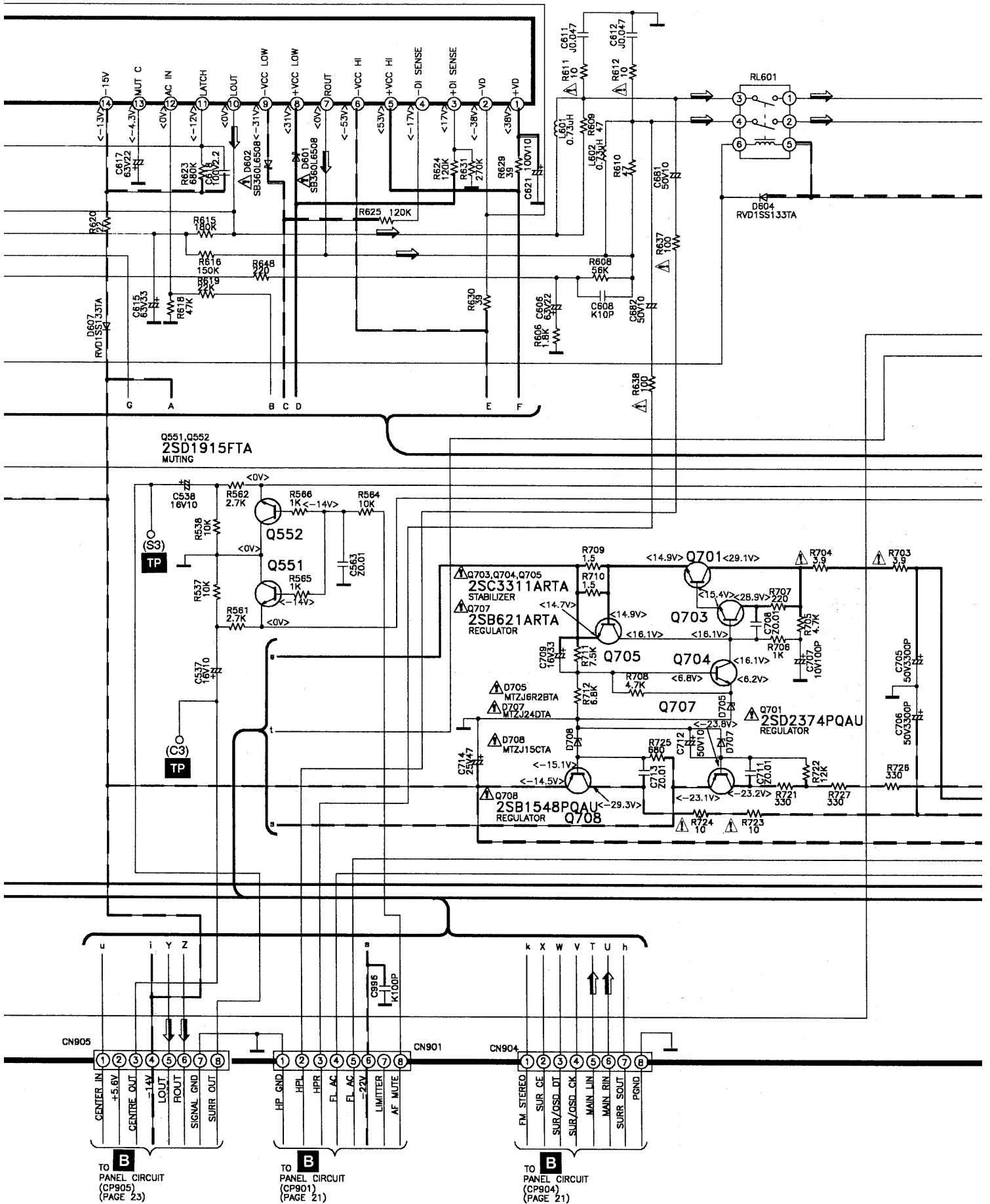

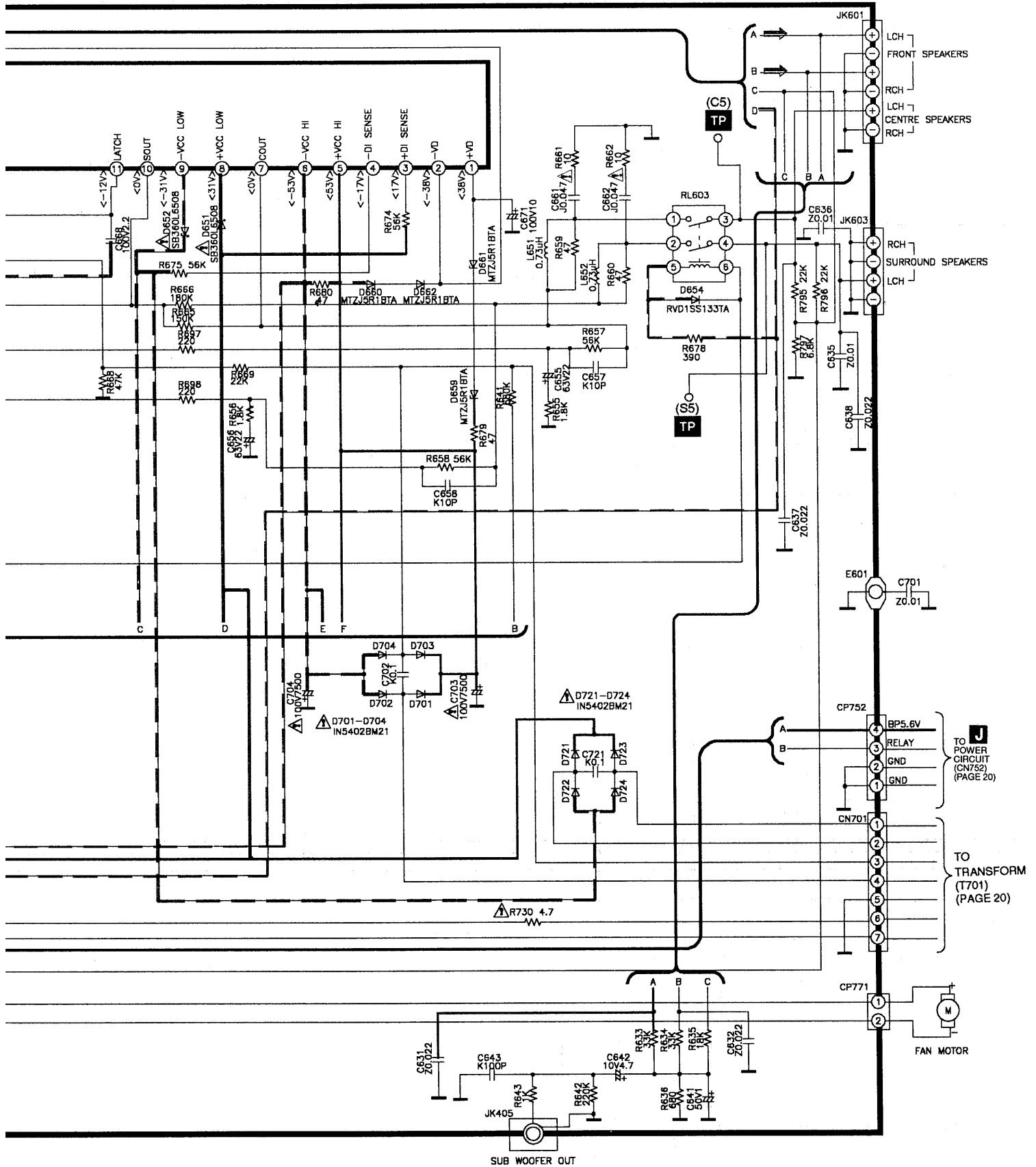

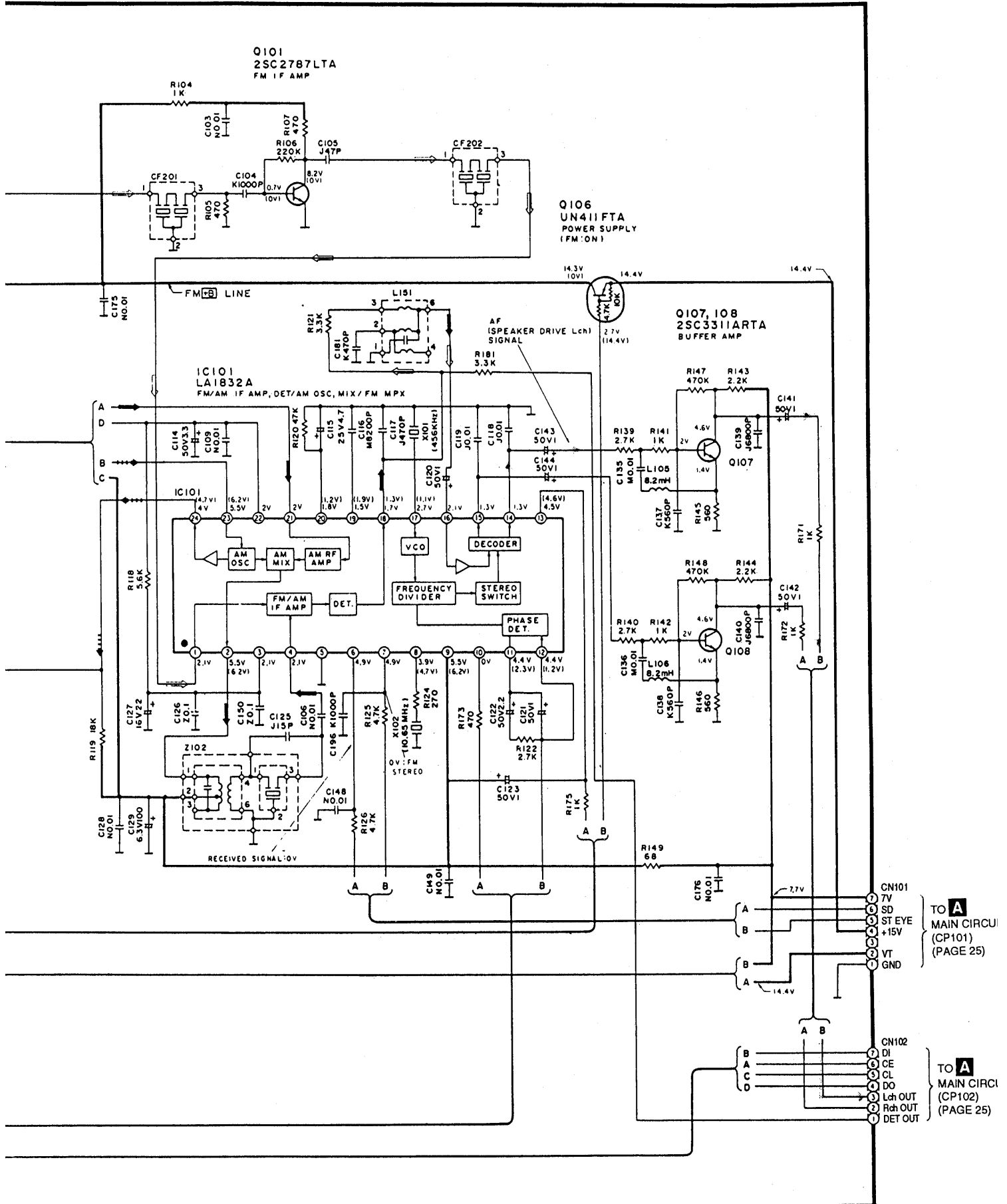

F TUNER CIRCUIT For (E,EB) areas

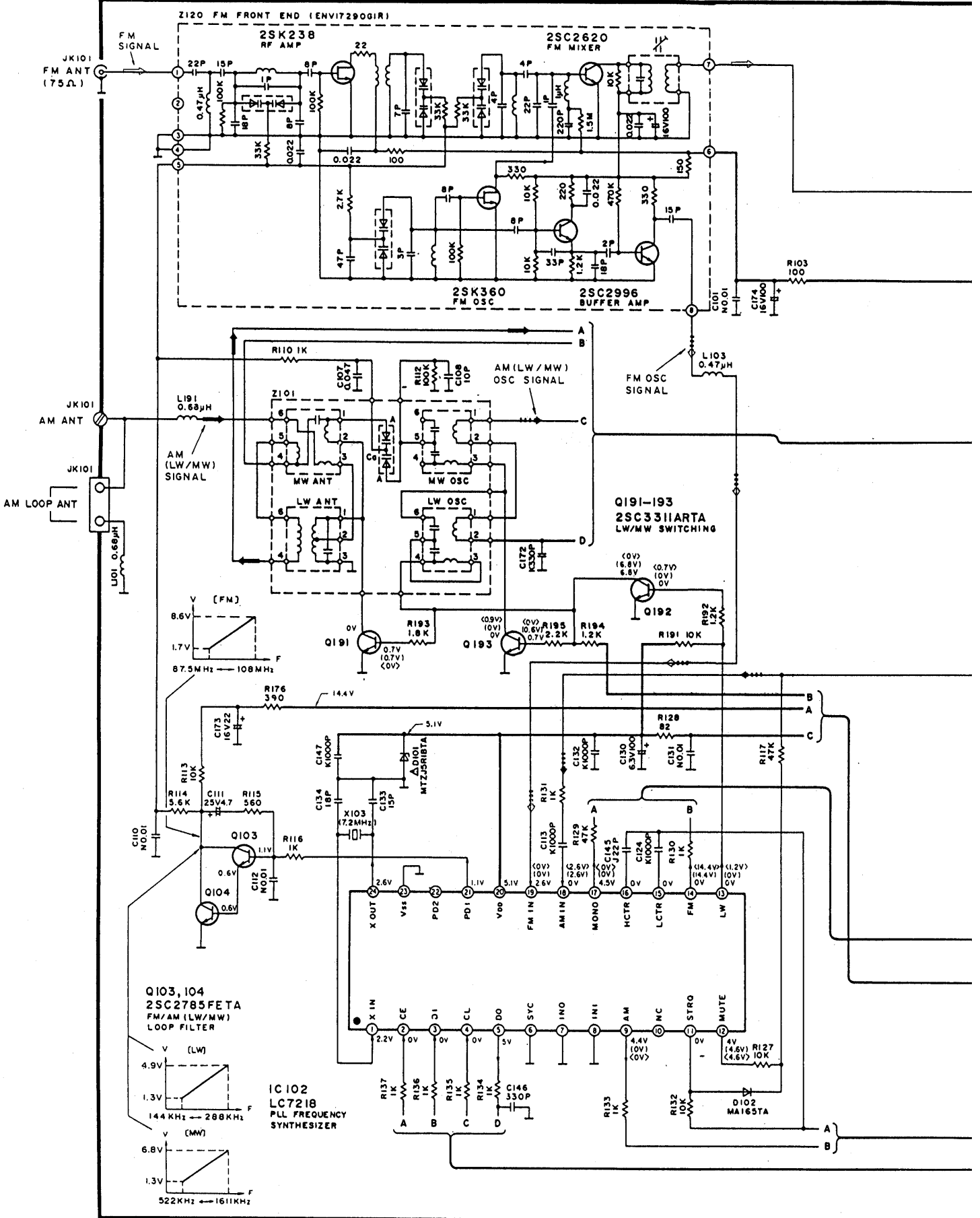

PRO LOGIC CIRCUIT

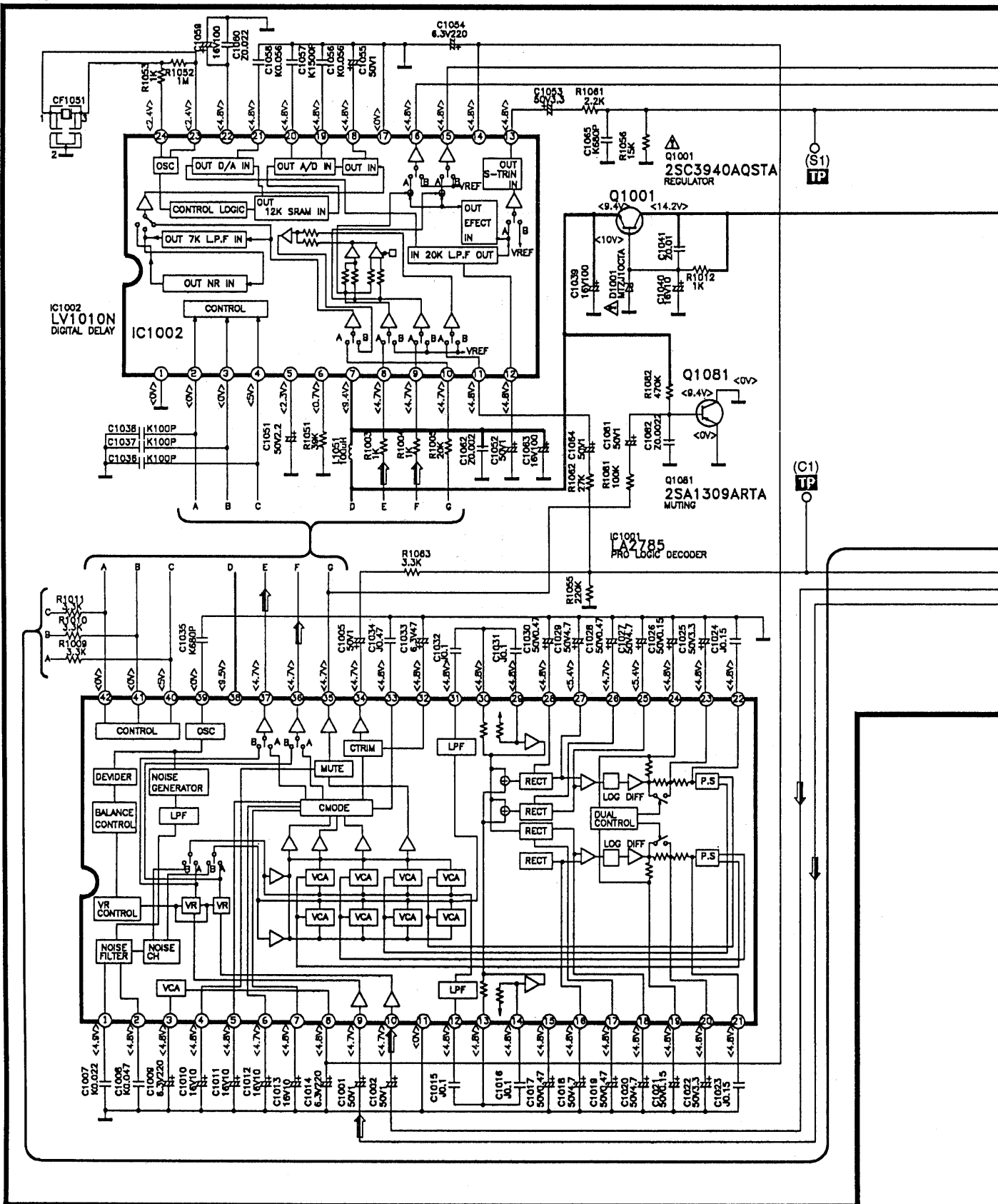

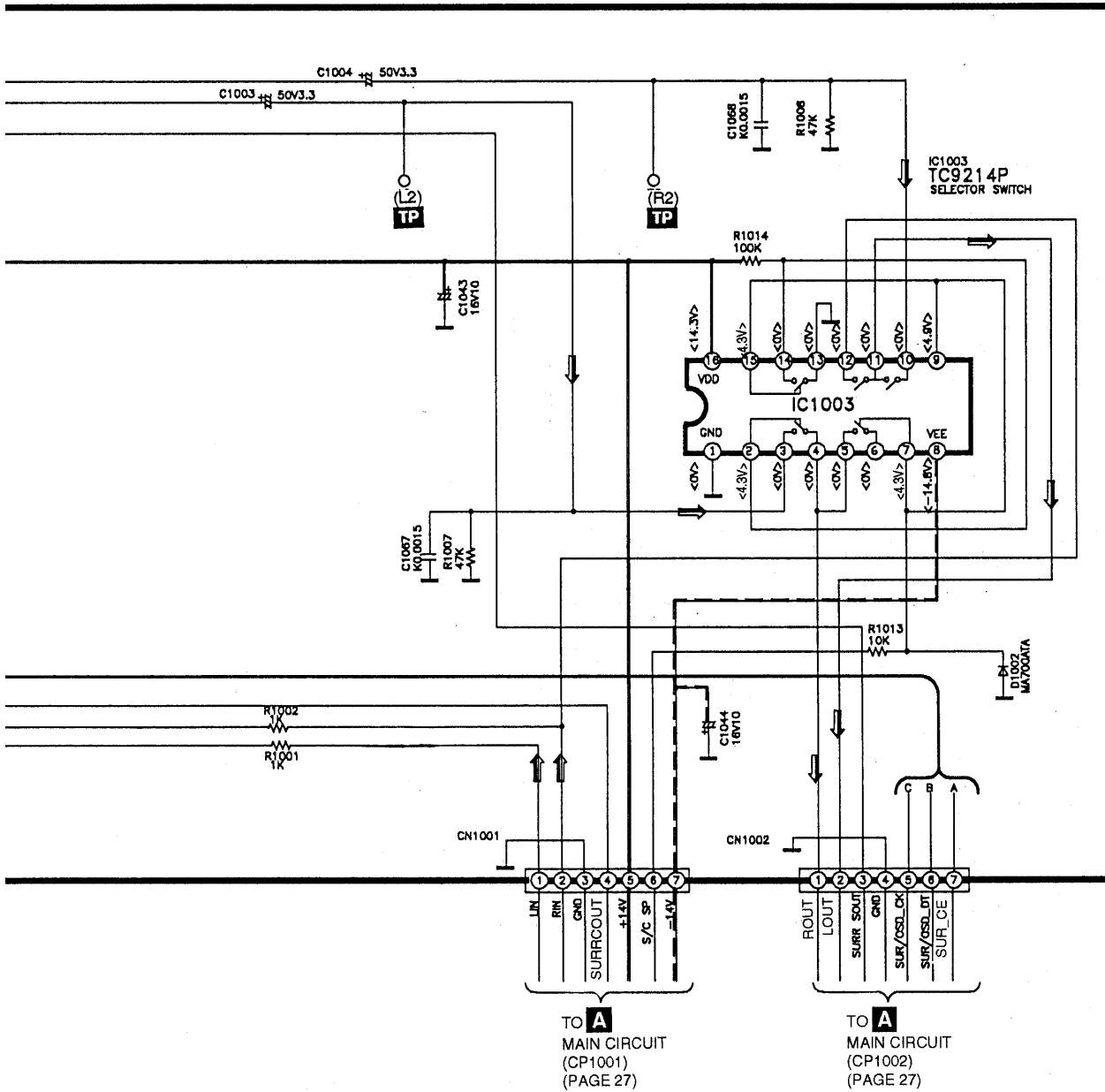

E HEADPHONE JACK CIRCUIT

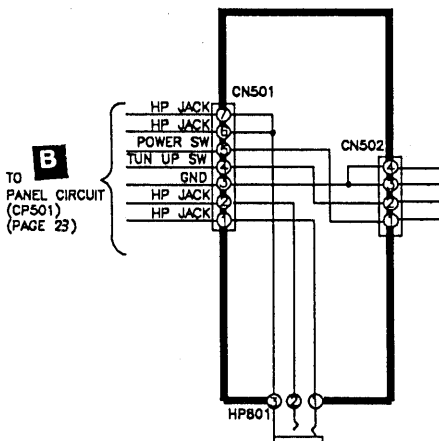

D POWER SWITCH CIRCUIT

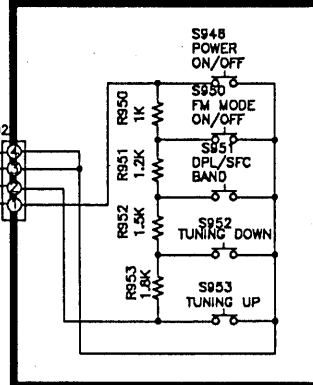

■ Printed Circuit Board

■ TUNER P.C.B. (REP2158B-T)...E,EB

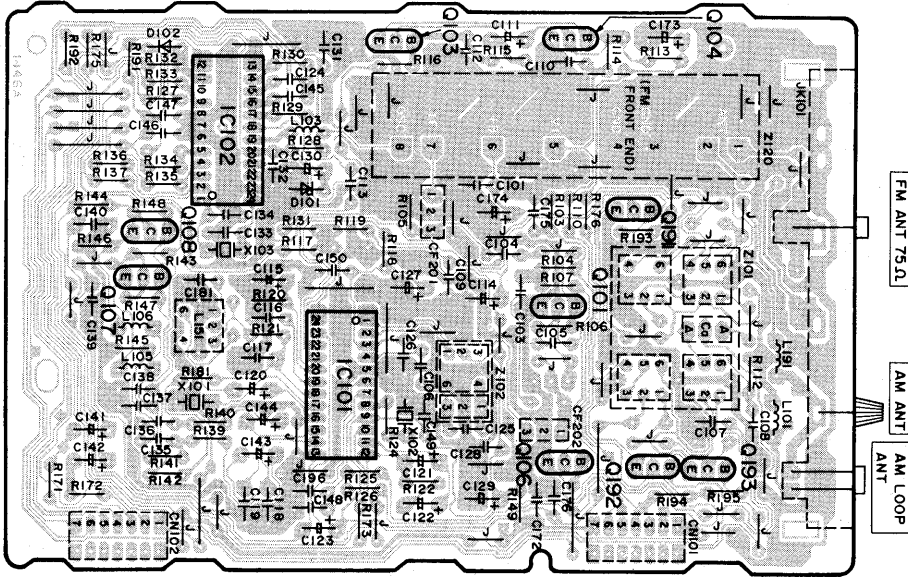

■ TUNER P.C.B. (REP2158A-T)...EG

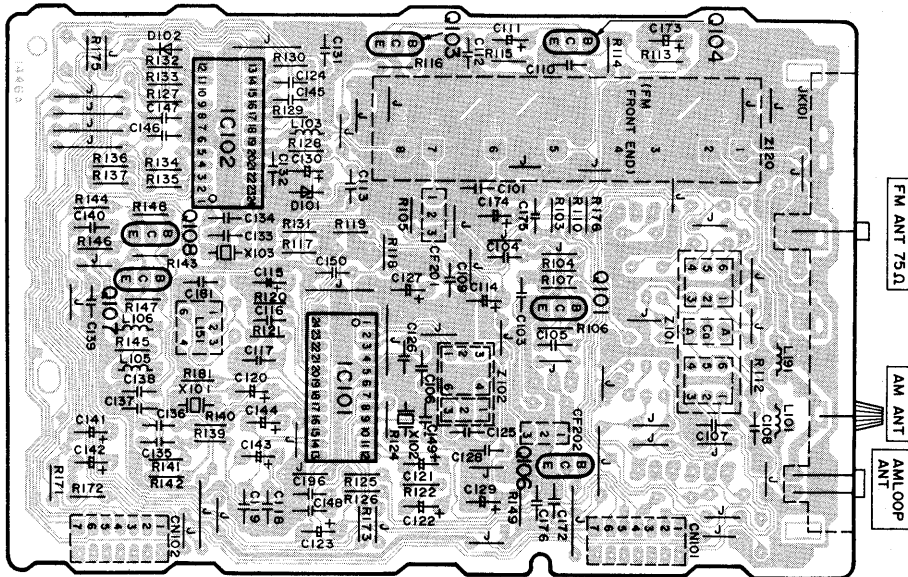

C MOTOR P.C.B. (REP2303B-S)
(REP2303C-S)

B PANEL P.C.B. (REP2303B-S)
(REP2303C-S)

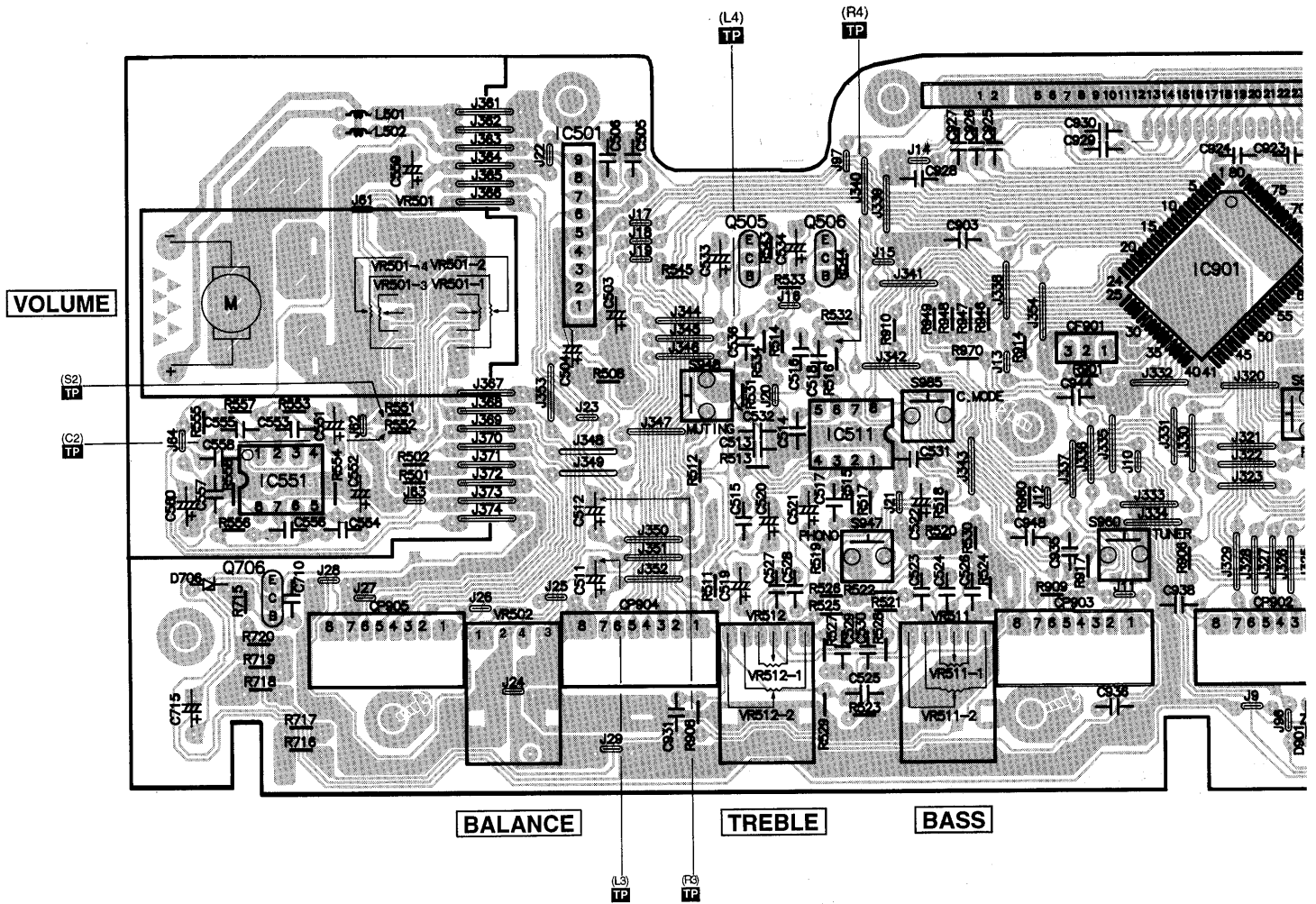

E HEADPHONE JACK P.C.B. (REP2303B-S)...E,EB
(REP2303C-S)...EG

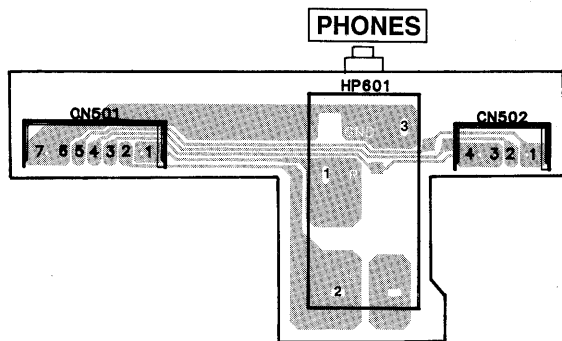

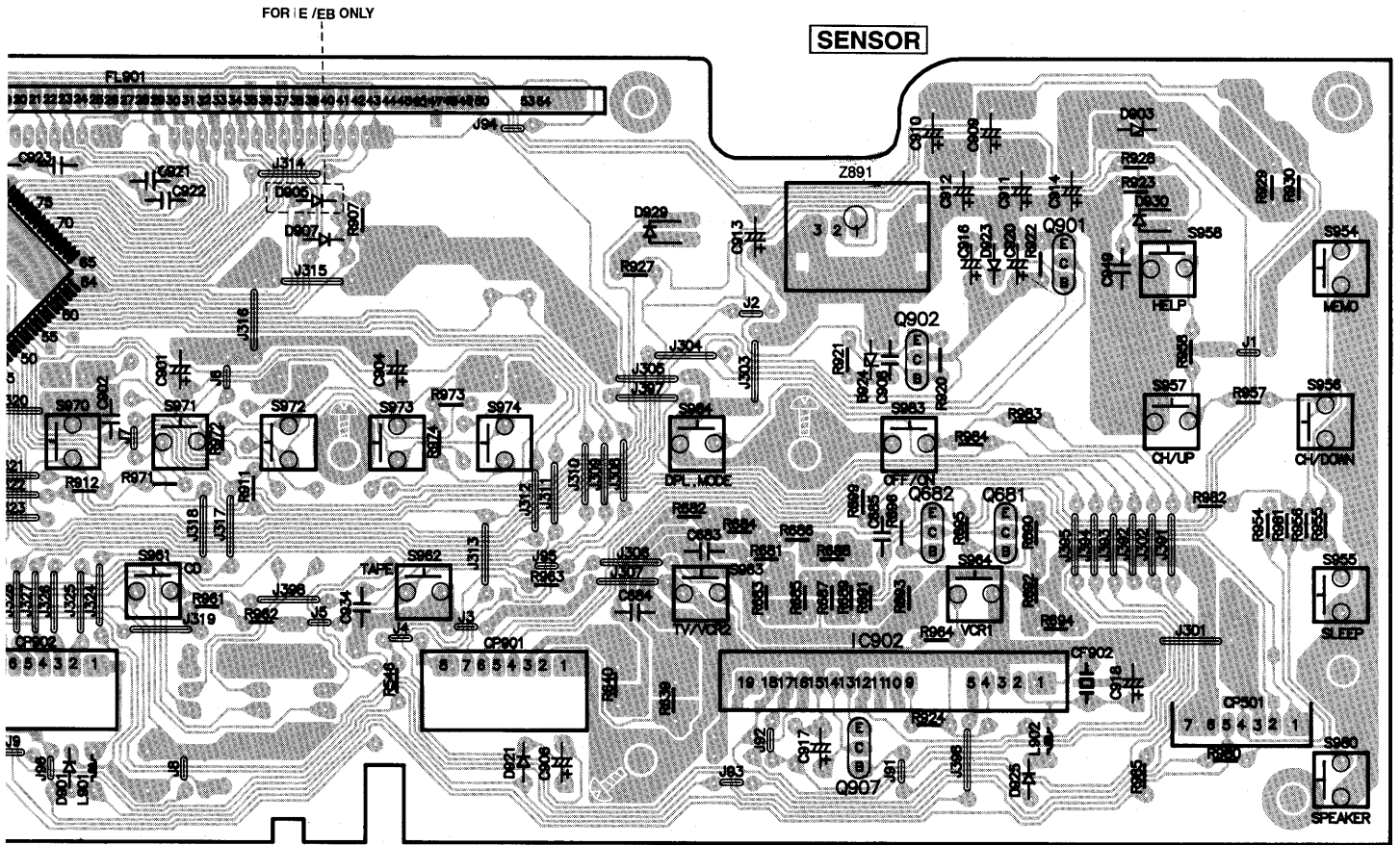

D POWER SWITCH P.C.B. (REP2303B-S)...E,EB
(REP2303C-S)...EG

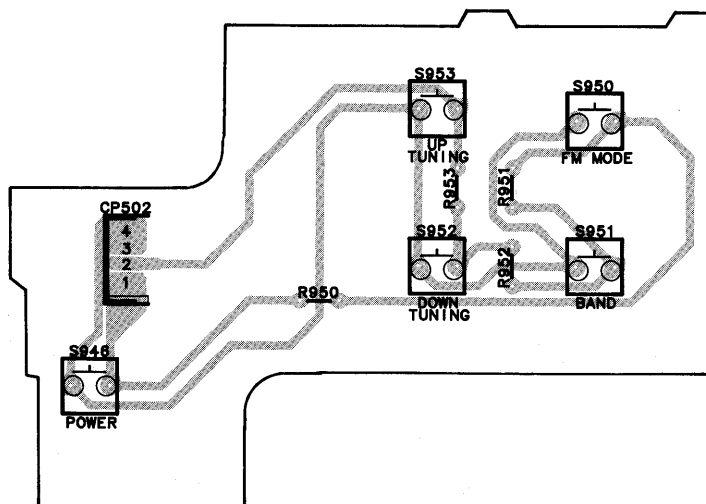

A MAIN P.C.B. (REP2302B-M)

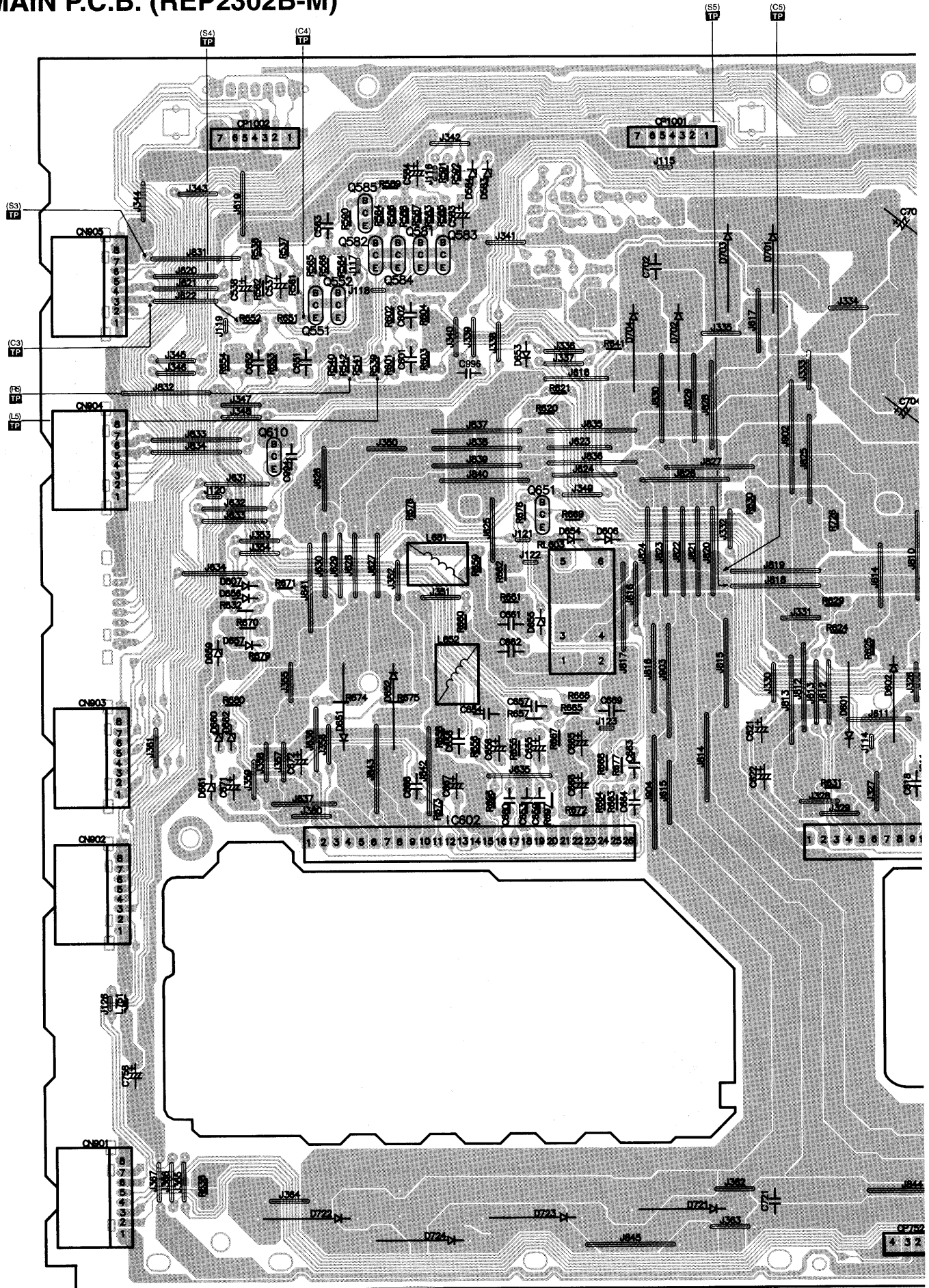

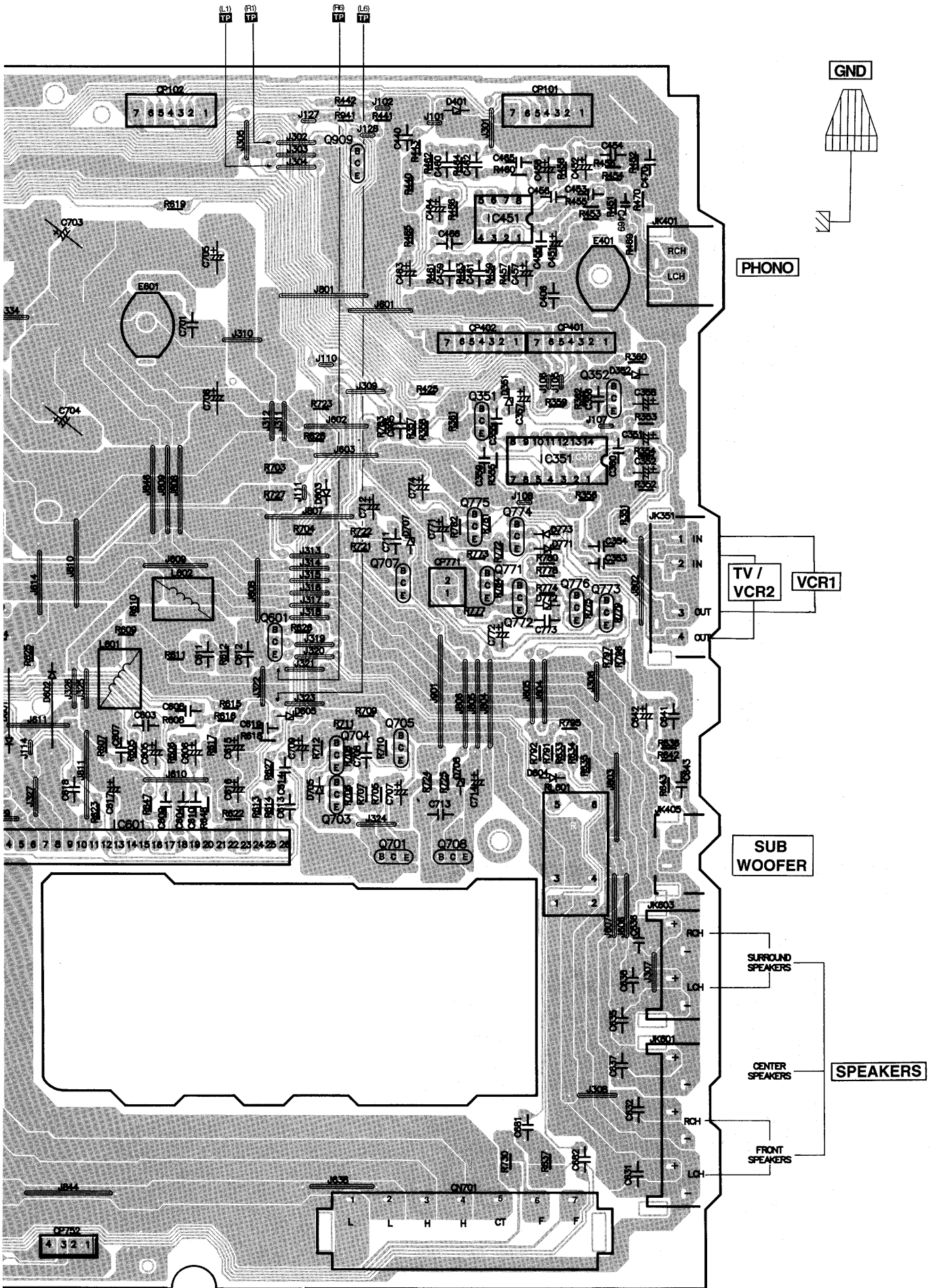

I PRO LOGIC P.C.B. (REP2241A-T)

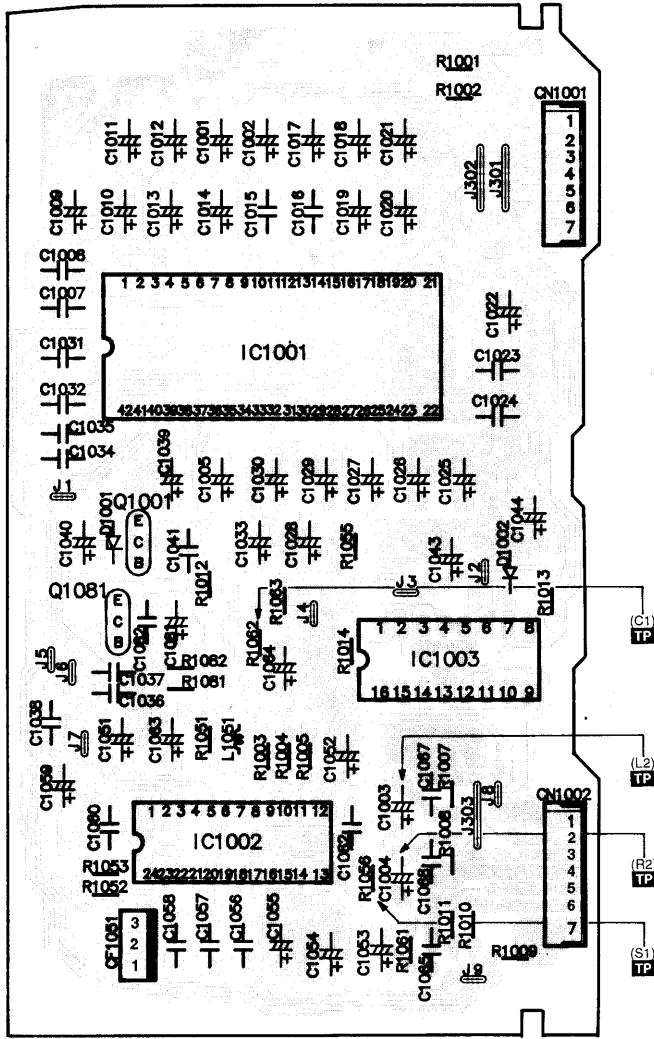

H IN/OUT TERMINAL P.C.B. (REP2302B-M)

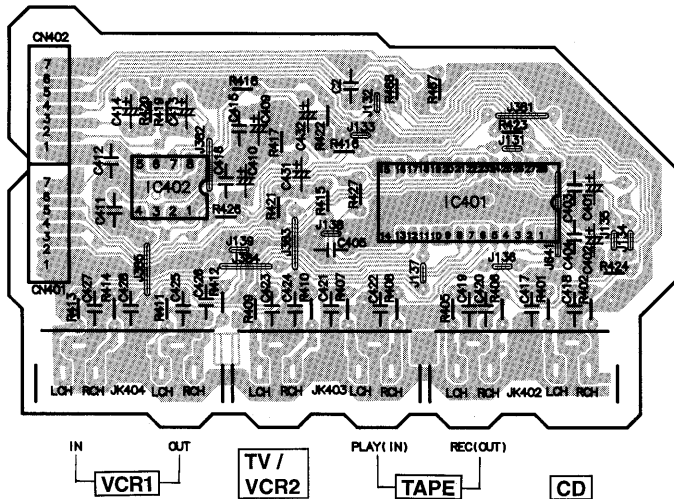

J POWER P.C.B. (REP2304B-P)...E,EB

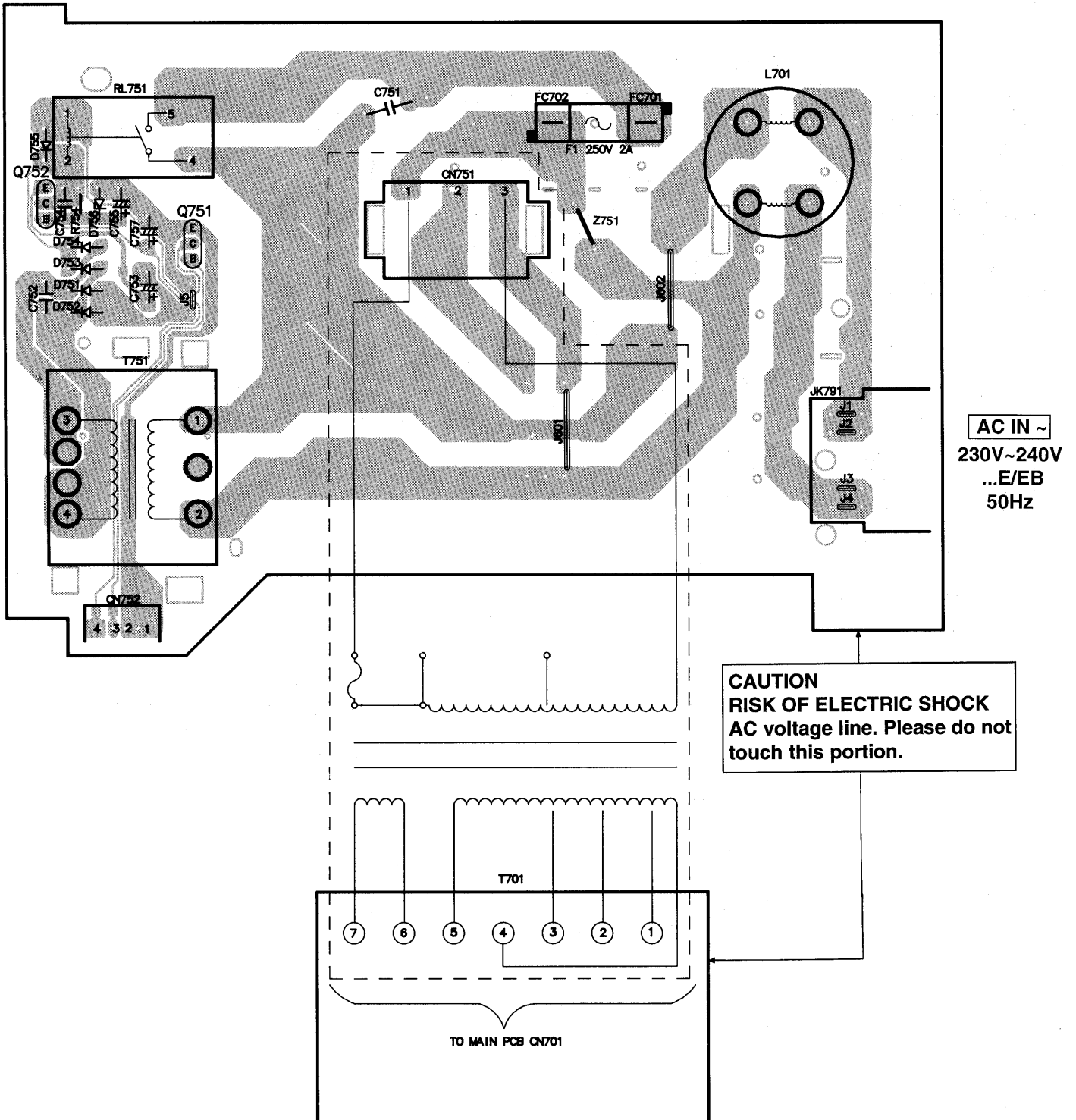

J POWER P.C.B. (REP2304C-P)...EG

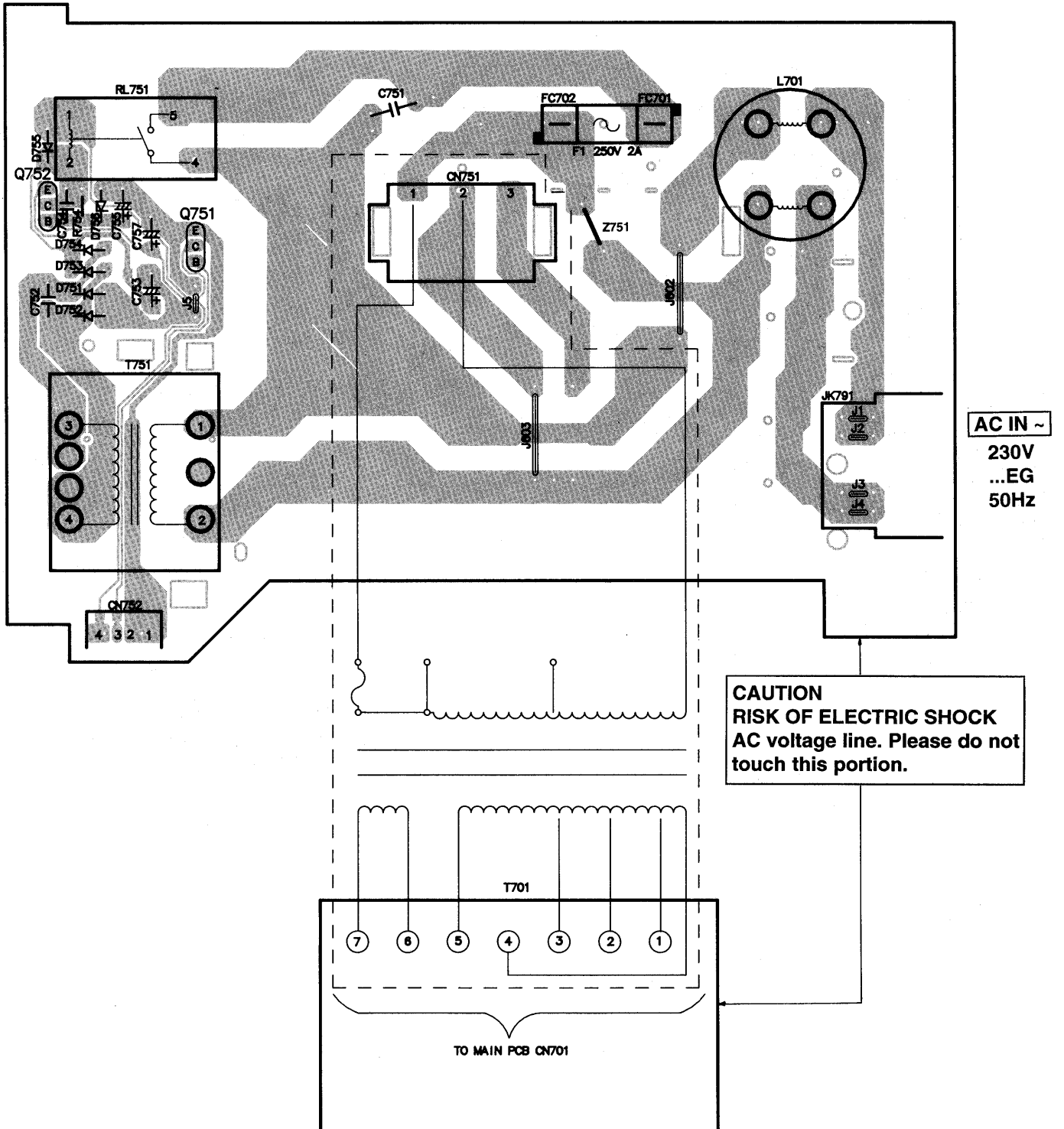

Wiring Connection Diagram

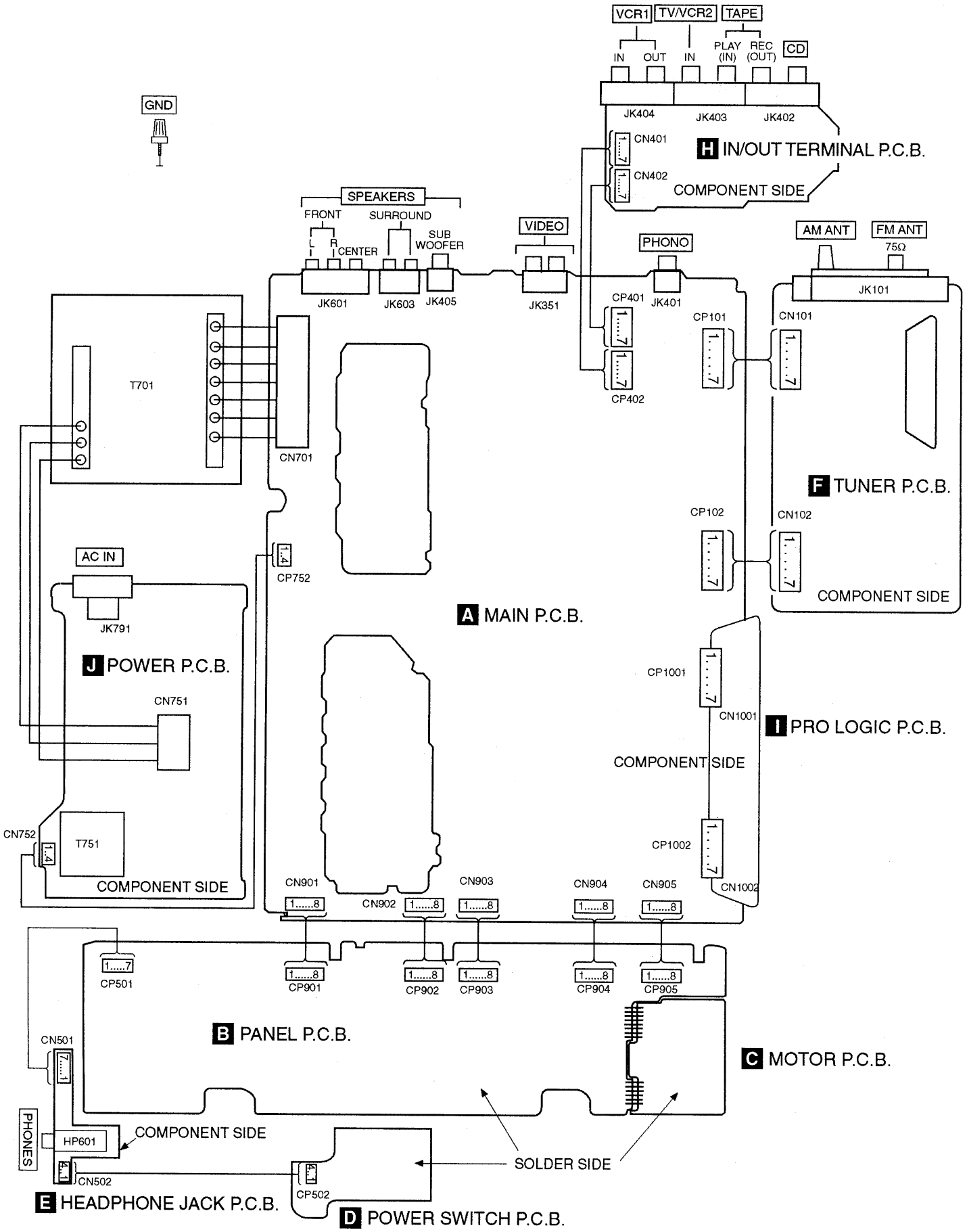

■ Cabinet Parts Location

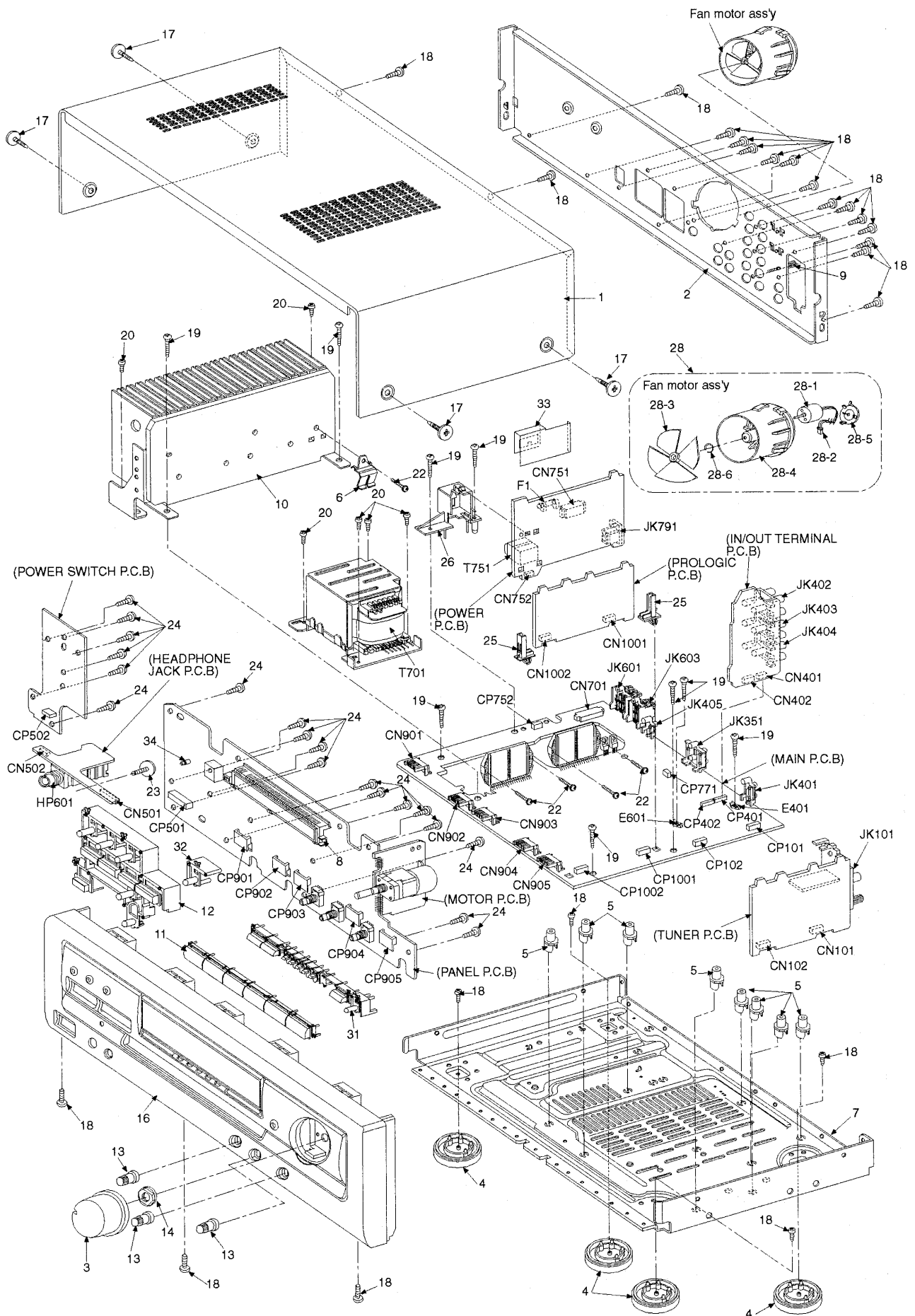

■ Replacement Parts List

Notes: * Important safety notice :

Components identified by  mark have special characteristics important for safety.

Furthermore, special parts which have purposes of fire-retardant (resistors), high-quality sound (capacitors), low-noise (resistors), etc. are used. When replacing any of components, be sure to use only manufacturer's specified parts shown in the parts list.

* The parenthesized in the Remarks columns specify the areas. (Refer to the cover page for area.)

Parts without these indication can be used for all areas.

* [M] in Remarks column indicates parts that are supplied by **MESA**.

* [MAV] in Remarks column indicates parts that are supplied by **MAV**.

* [VRD] in Remarks column indicates parts that are supplied by **Video Recorder Division**.

* Remote Control Unit : Supply period for three years from terminal of production.

* The "(SF)" mark denotes the standard part.

Ref No.	Part No.	Part Name & Description	Remarks	Ref No.	Part No.	Part Name & Description	Remarks	Ref No.	Part No.	Part Name & Description	Remarks
		CABINET AND CHASSIS				INTEGRATED CIRCUITS		Q584	2SC3311ARTA	TRANSISTOR	
1	RKM0319A-K	CABINET	[MAV]	IC101	LA1832A	IC, IF/MPX		Q585	2SA1309ARTA	TRANSISTOR	
2	RGR0234D-B1	REAR PANEL	[MAV](E)	IC102	LC7218	IC, PLL		Q601	UN4119TA	TRANSISTOR	
2	RGR0234D-C	REAR PANEL	[MAV](EB)	IC351	NJM2279D	IC, VIDEO SELECTOR SW		Q610	2SC3311ARTA	TRANSISTOR	
2	RGR0234D-A	REAR PANEL	[MAV](EG)	IC401	TC9163N	IC, SELECTOR		Q651	UN4119TA	TRANSISTOR	
3	RGW0243A-K	VOLUME KNOB	[MAV]	IC402	M5218AP	IC, BUFFER AMP		Q681	2SD1915FTA	TRANSISTOR	
4	RKA0079-A	FOOT	[MAV]	IC402	M5218AP	IC, BUFFER AMP		Q682	2SD1915FTA	TRANSISTOR	
5	RKQ0089	PCB SUPPORT		IC451	AN6558-F	IC, OP AMP	[M]	Q701	2SD2374PQAU	TRANSISTOR	
6	RMC0158-S	TR FIXTURE	[M]	IC501	BA6218	IC, MOTOR DRIVER		Q703	2SC3311ARTA	TRANSISTOR	
7	RMK0313	BOTTOM CHASSIS	[MAV]	IC511	UPC4570C	IC, TONE CONTROL		Q704	2SC3311ARTA	TRANSISTOR	
8	RMN0372	FL HOLDER	[MAV]	IC551	UPC4570C	IC, TONE CONTROL		Q705	2SC3311ARTA	TRANSISTOR	
9	SNE2123	EARTH TERMINAL		IC601	RSN3305-P	IC, HIC	[MAV] 	Q706	2SC3940AQSTA	TRANSISTOR	
10	RXX0166	HEAT SINK UNIT	[MAV]	IC602	RSN3305-P	IC, HIC	[MAV] 	Q707	2SB621ARTA	TRANSISTOR	
11	RGU1351-K	SELECTOR BUTTON	[MAV]	IC901	UPD78043A047	IC, MICRO COMPUTER	[MAV]	Q708	2SB1548PQAU	TRANSISTOR	
12	RGU1350A-K	MODE BUTTON	[MAV]	IC902	STK311-010	IC, RDS DECODER	[M]	Q751	UN421FTA	TRANSISTOR	
13	RGW0244-K	BASS TREBLE KNOB	[MAV]	IC1001	LA2785	IC, PRO LOGIC DECODER		Q752	2SC3940AQSTA	TRANSISTOR	
14	RHN90001	M9 NUT		IC1002	LV1010N	IC, DIGITAL DELAY		Q771	2SA1309ARTA	TRANSISTOR	
16	RFKGAEX500EK	FRONT PANEL ASS'Y	[MAV]	IC1003	TC9214P	IC, SELECTOR SWITCH		Q772	2SA1309ARTA	TRANSISTOR	
17	SNE2129-1	SCREW (CABINET)						Q773	2SB621ARTA	TRANSISTOR	
18	XTBS3+8JFZ1	SCREW						Q774	2SA1309ARTA	TRANSISTOR	
19	XTB3+20JFZ	SCREW						Q775	2SA1309ARTA	TRANSISTOR	
20	XTB3+8FFZ	SCREW						Q776	2SA1309ARTA	TRANSISTOR	
22	XTW3+15T	SCREW		Q101	2SC2787LTA	TRANSISTOR		Q901	RVTDC114YST	TRANSISTOR	
23	RHD26016	SCREW		Q103	2SC2785FETA	TRANSISTOR		Q902	2SA933SSTA	TRANSISTOR	
24	XTBS26+10J	SCREW		Q104	2SC2785FETA	TRANSISTOR		Q907	RVTDC114YST	TRANSISTOR	
25	RMN0203	PCB HOLDER		Q106	UN411FTA	TRANSISTOR		Q909	2SC3311ARTA	TRANSISTOR	
26	RMN0338	TRANS HOLDER		Q107	2SC3311ARTA	TRANSISTOR		Q1001	2SC3940AQSTA	TRANSISTOR	
28	RYQ0173-K	FAN UNIT	[MAV]	Q108	2SC3311ARTA	TRANSISTOR		Q1081	2SA1309ARTA	TRANSISTOR	
28-1	MDN-4RB4MRC	MOTOR		Q191	2SC3311ARTA	TRANSISTOR	(EB)(E)				
28-2	REX0811	CONNECTOR UNIT	[MAV]	Q192	2SC3311ARTA	TRANSISTOR	(EB)(E)				
28-3	SHE232	64MM FAN		Q193	2SC3311ARTA	TRANSISTOR	(EB)(E)				
28-4	SHE233-1	FAN CASE		Q351	2SD592ARTA	TRANSISTOR					
28-5	SHE234	FAN CASE COVER		Q352	2SB621ARTA	TRANSISTOR		D101	MTZJ5R1BTA	DIODE	
28-6	SUS271	MOTOR SPRING		Q505	2SD1915FTA	TRANSISTOR		D102	MA165TA	DIODE	
31	RGU1352F-K	DOLBY BUTTON	[MAV]	Q506	2SD1915FTA	TRANSISTOR		D351	MTZJ5R6BTA	DIODE	
32	RGU1398-Q	HELP BUTTON	[MAV]	Q551	2SD1915FTA	TRANSISTOR		D352	MTZJ5R6BTA	DIODE	
33	RMV0122	BARRIER	[MAV]	Q552	2SD1915FTA	TRANSISTOR		D401	MTZJ7R5CCTA	DIODE	
34	RMN0313	LED SUPPORT		Q581	2SA1309ARTA	TRANSISTOR		D583	MTZJ3R0ATA	DIODE	[MAV]
				Q582	2SA1309ARTA	TRANSISTOR		D584	MTZJ3R0ATA	DIODE	[MAV]
				Q583	2SC3311ARTA	TRANSISTOR		D601	SB360L6508	DIODE	

Ref No.	Part No.	Part Name & Description	Remarks	Ref No.	Part No.	Part Name & Description	Remarks	Ref No.	Part No.	Part Name & Description	Remarks
D602	SB360L6508	DIODE	⚠	D1001	MTZJ10CTA	DIODE	⚠	CN751	SJS305-1	CONNECTOR (3P)	
D603	RVD1SS133TA	DIODE		D1002	MA700ATA	DIODE		CN752	RJU100W04	SOCKET (4P)	[MAV]
D604	RVD1SS133TA	DIODE						CN901	RJU003K008M1	BOARD IN CONNECTOR	
D605	MTZJ6R2BTA	DIODE				VARIABLE RESISTORS		CN902	RJU003K008M1	BOARD IN CONNECTOR	
D606	RVD1SS133TA	DIODE						CN903	RJU003K008M1	BOARD IN CONNECTOR	
D607	RVD1SS133TA	DIODE		VR501	RRV24B02B16A	VR, MOTOR VOLUME	[MAV]	CN904	RJU003K008M1	BOARD IN CONNECTOR	
D651	SB360L6508	DIODE	⚠	VR502	EVJ02QF01G15	VR, BALANCE CONTROL		CN905	RJU003K008M1	BOARD IN CONNECTOR	
D652	SB360L6508	DIODE	⚠	VR511	EVJYA1F01C15	VR, BASS CONTROL		CN1001	RJU100W07	7P CONNECTOR	[MAV]
D653	RVD1SS133TA	DIODE		VR512	EVJYA1F01C15	VR, TREBLE CONTROL		CN1002	RJU100W07	7P CONNECTOR	[MAV]
D654	RVD1SS133TA	DIODE						CP101	RJT057W007-1	7P CONNECTOR	
D655	MTZJ6R2BTA	DIODE				SWITCHES		CP102	RJT057W007-1	7P CONNECTOR	
D656	RVD1SS133TA	DIODE						CP401	RJT100W07	7P CONNECTOR	[MAV]
D657	RVD1SS133TA	DIODE		S946	EVQ21405R	SW, POWER		CP402	RJT100W07	7P CONNECTOR	[MAV]
D659	MTZJ5R1BTA	DIODE		S947	EVQ21405R	SW, PHONO		CP501	RJT100W07	7P CONNECTOR	[MAV]
D660	MTZJ5R1BTA	DIODE		S948	EVQ21405R	SW, MUTING		CP502	RJT100W04	CONNECTOR (4P)	[MAV]
D661	MTZJ5R1BTA	DIODE		S950	EVQ21405R	SW, FM MODE		CP752	RJT100W04	CONNECTOR (4P)	[MAV]
D662	MTZJ5R1BTA	DIODE		S951	EVQ21405R	SW, BAND		CP771	SJT3213	CONNECTOR (FAN)	
D701	1N5402BM21	DIODE	⚠	S952	EVQ21405R	SW, TUNING DOWN		CP901	RJT003K008M1	8P CONNECTOR	
D702	1N5402BM21	DIODE	⚠	S953	EVQ21405R	SW, TUNING UP		CP902	RJT003K008M1	8P CONNECTOR	
D703	1N5402BM21	DIODE	⚠	S954	EVQ21405R	SW, MEMORY		CP903	RJT003K008M1	8P CONNECTOR	
D704	1N5402BM21	DIODE	⚠	S955	EVQ21405R	SW, SLEEP		CP904	RJT003K008M1	8P CONNECTOR	
D705	MTZJ6R2BTA	DIODE	⚠	S956	EVQ21405R	SW, PRESET DOWN		CP905	RJT003K008M1	8P CONNECTOR	
D706	MTZJ6R2BTA	DIODE	⚠	S957	EVQ21405R	SW, PRESET UP		CP1001	RJT100W07	7P CONNECTOR	[MAV]
D707	MTZJ24DTA	DIODE	⚠	S958	EVQ21405R	SW, HELP		CP1002	RJT100W07	7P CONNECTOR	[MAV]
D708	MTZJ15CTA	DIODE	⚠	S960	EVQ21405R	SW, TUNER					
D721	1N5402BM21	DIODE	⚠	S961	EVQ21405R	SW, CD				COILS & TRANSFORMERS	
D722	1N5402BM21	DIODE	⚠	S962	EVQ21405R	SW, TAPE MONITOR		L101	ELESNR68MA	CHOKE COIL	(EB)(E)
D723	1N5402BM21	DIODE	⚠	S963	EVQ21405R	SW, TV/VCR2		L101	ELESNR68MA	CHOKE COIL	(EG)
D724	1N5402BM21	DIODE	⚠	S964	EVQ21405R	SW, VCR1		L103	ELEXP47MA9	CHOKE COIL	
D751	1SR35200TB	DIODE	⚠	S970	EVQ21405R	SW, SIMULATED		L105	RLQZB822KT-D	TAPING COIL	
D752	1SR35200TB	DIODE	⚠	S971	EVQ21405R	SW, THEATER		L106	RLQZB822KT-D	TAPING COIL	
D753	1SR35200TB	DIODE	⚠	S972	EVQ21405R	SW, LIVE		L151	SLM1B10-1M	COIL	
D754	1SR35200TB	DIODE	⚠	S973	EVQ21405R	SW, CLUB		L191	ELESNR68MA	CHOKE COIL	(EB)(E)
D755	RVD1SS133TA	DIODE	⚠	S974	EVQ21405R	SW, HALL		L191	ELESNR56MA	CHOKE COIL	(EG)
D756	MTZJ6R8BTA	DIODE	⚠	S980	EVQ21405R	SW, SPEAKERS		L501	RLQZP1R0KT-Y	AXIAL COIL	
D771	RVD1SS133TA	DIODE		S983	EVQ21405R	SW, OFF/ON		L502	RLQZP1R0KT-Y	AXIAL COIL	
D772	MTZJ6R8BTA	DIODE		S984	EVQ21405R	SW, PRO LOGIC		L601	RLQYR73M	CHOKE COIL	
D773	RVD1SS133TA	DIODE		S985	EVQ21405R	SW, CENTER MODE		L602	RLQYR73M	CHOKE COIL	
D901	1SS291TA	DIODE						L651	RLQYR73M	CHOKE COIL	
D903	MTZJ4R7BTA	DIODE				CONNECTORS		L652	RLQYR73M	CHOKE COIL	
D905	RVD1SS133TA	DIODE	(EB)(E)					L701	SLQZ650MH49	AC LINE COIL	⚠
D907	RVD1SS133TA	DIODE		CN101	RJU057W007	CONNECTOR (7P)		L751	RLQB101KTA-Y	CHOKE COIL	
D921	RVD1SS133TA	DIODE		CN102	RJU057W007	CONNECTOR (7P)		L901	RLQB101KTA-Y	CHOKE COIL	
D923	RVD1SS133TA	DIODE		CN401	RJU100W07	7P CONNECTOR	[MAV]	L902	RLQZP101KT-Y	AXIAL COIL	
D924	MTZJ3R9ATA	DIODE		CN402	RJU100W07	7P CONNECTOR	[MAV]	L1051	RLQB101KTA-Y	CHOKE COIL	
D925	MA723TA	DIODE		CN501	RJU100W07	7P CONNECTOR	[MAV]	T701	RTP1P5E025-V	POWER TRANSFORMER	[MAV]⚠
D929	LN846RPH	DIODE		CN502	RJU100W04	SOCKET (4P)	[MAV]	T751	RTP1I5E006	POWER TRANSFORMER	⚠
D930	LN41YCPHL	DIODE		CN701	SJS702-1	7P CONNECTOR					

Ref No.	Part No.	Part Name & Description	Remarks	Ref No.	Part No.	Part Name & Description	Remarks	Ref No.	Part No.	Part Name & Description	Remarks
		COMPONENT COMBINATION				FUSES				HEADPHONE	
Z101	RLA6Z005M-T	AM ANT/OSC	(EB)(E)	F1	XBA2C20TB0	FUSE	⚠	HP601	RJJ63TS01	HEADPHONES JACK	
Z101	RLA2Z002M-T	AM ANT. COIL	(EG)								
Z102	RLI2Z006M-T	AM IFT				FUSE CLIPS				EARTH TERMINAL	
Z120	ENV17290G1R	FM TUNER PACK									
Z751	ERZV10V511CS	ZNR	⚠	FC701	RJR0169T	FUSE HOLDER	[M]	E401	SNE1004-2	EARTH TERMINAL	
Z891	RCDS4242N	REMOTE SENSOR		FC702	RJR0169T	FUSE HOLDER	[M]	E601	SNE1004-2	EARTH TERMINAL	
		CERAMIC FILTERS				JACKS				PACKING MATERIALS	
CF201	RLFFETNGD01L	CERAMIC FILTER		JK101	RJH4202	ANT TERMINAL		P1	SPSD152	ACCESSORY CASE	
CF202	RLFFETMGD01L	CERAMIC FILTER		JK351	SJF3069-3N	RCA PIN JACK		P2	RPF00005	MIRAMAT BAG	[M]
CF901	RVBCST4R00MT	CERAMIC CAPACITOR		JK401	SJF3066-7N	RCA TERMINAL		P3	RPG3054-1	GIFT BOX	[MAV]
CF902	RSXZ456KM07M	CERAMIC OSCILLATOR		JK402	SJF3069N	LINE IN JACK		P4	RPN0865	POLYFOAM	[M]
CF1051	EF0EC8004T4	CERAMIC OSCILLATOR		JK403	SJF3069N	LINE IN JACK					
				JK404	SJF3069N	LINE IN JACK				ACCESSORIES	
		OSCILLATORS		JK405	SJFD7	FM MULTI OUT					
				JK601	RJH5601	SP TERMINAL		A1	RAK-SA612WHP	REMOTE CON. UNIT	[MAV]
X101	RSXZ456KM07M	CERAMIC OSCILLATOR		JK603	RJR0054	SP TERMINAL		A1-1	RKK0020	REMOTE CON. COVER	
X102	RLFDGTD011	FM REZONATOR		JK791	SJS9236	SOCKET	⚠	A2	RSA0010	AM LOOP ANT	
X103	SVQ49U722T-S	CRYSTAC OSCILLIATOR						A3	VJA0733	AC-CORD (SF) ⚠	[VRD](EB)
						RELAYS		A3	RJA0019-2K	AC CORD (SF) (EG)(E) ⚠	
		DISPLAY TUBE						A4	RSA0007	FM ANTENA	
				RL601	RSY0013M-0	24V RELAY		A5	RFKSAEX500EK	INSTR. MANUAL ASS'Y	[MAV](E)
FL901	RSL0213-F	FL DISPLAY	[MAV]	RL603	RSY0013M-0	24V RELAY		A5	RFKSAEX500EB	INSTR. MANUAL ASS'Y	[MAV](EB)
				RL751	RSY0019M-0	12V TV-5 RELAY	⚠	A5	RFKSAEX500EG	INSTR. MANUAL ASS'Y	[MAV](EG)
								A6	SJP9009	ANT ADAPTER	(EB)

Resistors & Capacitors

Notes : * Important safety notice:

Components identified by ⚠ mark have special characteristics important for safety.

Furthermore, special parts which have purposes of fire-retardant (resistors), high-quality sound (capacitors), low-noise (resistors), etc. are used. When replacing any of components, be sure to use only manufacturer's specified parts shown in the parts list.



* Capacitor values are in microfarad (μF) unless specified otherwise, P=Pico-farads (pF) F=Farads (F)

* Resistors values are in ohms, unless specified otherwise, 1k=1,000(OHM), 1M=1,000k(OHM)

Ref No.	Part No.	Values & Remarks	Ref No.	Part No.	Values & Remarks	Ref No.	Part No.	Values & Remarks	Ref No.	Part No.	Values & Remarks
		RESISTORS									
			R115	ERDS2TJ561T	560 1/4W	R127	ERDS2TJ103T	10K 1/4W	R139	ERDS2TJ272T	2.7K 1/4W
			R116	ERDS2TJ102T	1K 1/4W	R128	ERDS2TJ820T	82 1/4W	R140	ERDS2TJ272T	2.7K 1/4W
R103	ERDS2TJ101T	100 1/4W	R117	ERDS2TJ473T	47K 1/4W	R129	ERDS2TJ473T	47K 1/4W	R141	ERDS2TJ102T	1K 1/4W
R104	ERDS2TJ102T	1K 1/4W	R118	ERDS2TJ562T	5.6K 1/4W	R130	ERDS2TJ102T	1K 1/4W	R142	ERDS2TJ102T	1K 1/4W
R105	ERDS2TJ471T	470 1/4W	R119	ERDS2TJ183T	18K 1/4W	R131	ERDS2TJ102T	1K 1/4W	R143	ERDS2TJ222T	2.2K 1/4W
R106	ERDS2TJ224T	220K 1/4W	R120	ERDS2TJ473T	47K 1/4W	R132	ERDS2TJ103T	10K 1/4W	R144	ERDS2TJ222T	2.2K 1/4W
R107	ERDS2TJ471T	470 1/4W	R121	ERDS2TJ332T	3.3K 1/4W	R133	ERDS2TJ102T	1K 1/4W	R145	ERDS2TJ102T	1K 1/4W(EB)(E)
R110	ERDS2TJ102T	1K 1/4W	R122	ERDS2TJ272T	2.7K 1/4W	R134	ERDS2TJ102T	1K 1/4W	R145	ERDS2TJ561T	560 1/4W(EG)
R112	ERDS2TJ104T	100K 1/4W	R124	ERDS2TJ271T	270 1/4W	R135	ERDS2TJ102T	1K 1/4W	R146	ERDS2TJ102T	1K 1/4W(EB)(E)
R113	ERDS2TJ103T	10K 1/4W	R125	ERDS2TJ472T	4.7K 1/4W	R136	ERDS2TJ102T	1K 1/4W	R146	ERDS2TJ561T	560 1/4W(EG)
R114	ERDS2TJ562T	5.6K 1/4W	R126	ERDS2TJ472T	4.7K 1/4W	R137	ERDS2TJ102T	1K 1/4W	R147	ERDS2TJ474T	470K 1/4W

Ref No.	Part No.	Values & Remarks	Ref No.	Part No.	Values & Remarks	Ref No.	Part No.	Values & Remarks	Ref No.	Part No.	Values & Remarks
R148	ERDS2TJ474T	470K 1/4W	R426	ERDS2TJ103T	10K 1/4W	R530	ERDS2TJ273T	27K 1/4W	R611	ERDS1FVJ100T	10 1/2W ▲
R149	ERDS2TJ680T	68 1/4W	R427	ERDS2TJ103T	10K 1/4W	R531	ERDS2TJ332T	3.3K 1/4W	R612	ERDS1FVJ100T	10 1/2W ▲
R171	ERDS2TJ102T	1K 1/4W	R440	ERDS1FVJ820T	82 1/2W ▲	R532	ERDS2TJ332T	3.3K 1/4W	R613	ERDS2TJ102T	1K 1/4W
R172	ERDS2TJ102T	1K 1/4W	R441	ERDS2TJ473T	47K 1/4W	R533	ERDS2TJ224T	220K 1/4W	R614	ERDS2TJ102T	1K 1/4W
R173	ERDS2TJ471T	470 1/4W	R442	ERDS2TJ473T	47K 1/4W	R534	ERDS2TJ224T	220K 1/4W	R615	ERDS2TJ184T	180K 1/4W
R175	ERDS2TJ102T	1K 1/4W	R443	ERDS2TJ330T	33 1/4W	R537	ERDS2TJ103T	10K 1/4W	R616	ERDS2TJ154T	150K 1/4W
R176	ERDS2TJ391T	390 1/4W	R451	ERDS2TJ224T	220K 1/4W	R538	ERDS2TJ103T	10K 1/4W	R617	ERDS2TJ473T	47K 1/4W
R181	ERDS2TJ332T	3.3K 1/4W	R452	ERDS2TJ224T	220K 1/4W	R539	ERDS2TJ472T	4.7K 1/4W	R618	ERDS2TJ473T	47K 1/4W
R191	ERDS2TJ103T	10K 1/4W(EB)(E)	R453	ERDS2TJ391T	390 1/4W	R540	ERDS2TJ472T	4.7K 1/4W	R619	ERDS2TJ223T	22K 1/4W
R192	ERDS2TJ122T	1.2K 1/4W(EB)(E)	R454	ERDS2TJ391T	390 1/4W	R541	ERDS2TJ222T	2.2K 1/4W	R620	ERD25FVJ220T	22 1/4W
R193	ERDS2TJ182T	1.8K 1/4W(EB)(E)	R455	ERDS2TJ563T	56K 1/4W	R542	ERDS2TJ222T	2.2K 1/4W	R621	ERDS2TJ473T	47K 1/4W
R194	ERDS2TJ122T	1.2K 1/4W(EB)(E)	R456	ERDS2TJ563T	56K 1/4W	R543	ERDS2TJ102T	1K 1/4W	R622	ERDS2TJ224T	220K 1/4W
R195	ERDS2TJ222T	2.2K 1/4W(EB)(E)	R457	ERDS2TJ271T	270 1/4W	R544	ERDS2TJ102T	1K 1/4W	R623	ERDS2TJ684T	680K 1/4W
R351	ERDS2TJ680T	68 1/4W	R458	ERDS2TJ271T	270 1/4W	R545	ERDS2TJ684T	680K 1/4W	R624	ERDS2TJ124T	120K 1/4W
R352	ERDS2TJ680T	68 1/4W	R459	ERDS2TJ680T	68 1/4W	R546	ERDS2TJ103T	10K 1/4W	R625	ERDS2TJ124T	120K 1/4W
R353	ERDS2TJ103T	10K 1/4W	R460	ERDS2TJ680T	68 1/4W	R551	ERDS2TJ102T	1K 1/4W	R626	ERDS2TJ682T	6.8K 1/4W
R354	ERDS2TJ103T	10K 1/4W	R461	ERDS2TJ184T	180K 1/4W	R552	ERDS2TJ102T	1K 1/4W	R627	ERDS2TJ222T	2.2K 1/4W
R355	ERDS2TJ750T	75 1/4W	R462	ERDS2TJ184T	180K 1/4W	R553	ERDS2TJ104T	100K 1/4W	R628	ERD2FCVG391T	390 1/4W(MAV)
R356	ERDS2TJ750T	75 1/4W	R463	ERDS2TJ123T	12K 1/4W	R554	ERDS2TJ104T	100K 1/4W	R629	ERD25FVJ390T	39 1/4W
R357	ERDS2TJ102T	1K 1/4W	R464	ERDS2TJ123T	12K 1/4W	R555	ERDS2TJ223T	22K 1/4W	R630	ERD25FVJ390T	39 1/4W
R358	ERDS2TJ102T	1K 1/4W	R465	ERDS2TJ563T	56K 1/4W	R556	ERDS2TJ223T	22K 1/4W	R631	ERDS2TJ274T	270K 1/4W
R359	ERDS2TJ182T	1.8K 1/4W	R466	ERDS2TJ563T	56K 1/4W	R557	ERDS2TJ681T	680 1/4W	R632	ERDS2TJ223T	22K 1/4W
R360	ERDS2TJ182T	1.8K 1/4W	R467	ERDS2TJ102T	1K 1/4W	R558	ERDS2TJ681T	680 1/4W	R633	ERDS2TJ333T	33K 1/4W
R361	ERD2FCVG220T	22 1/4W	R468	ERDS2TJ102T	1K 1/4W	R561	ERDS2TJ272T	2.7K 1/4W	R634	ERDS2TJ333T	33K 1/4W
R362	ERD2FCVG220T	22 1/4W	R469	ERDS2TJ102T	1K 1/4W	R562	ERDS2TJ272T	2.7K 1/4W	R635	ERDS2TJ183T	18K 1/4W
R401	ERDS2TJ102T	1K 1/4W	R470	ERDS2TJ102T	1K 1/4W	R564	ERDS2TJ103T	10K 1/4W	R636	ERDS2TJ681T	680 1/4W
R402	ERDS2TJ102T	1K 1/4W	R501	ERDS2TJ222T	2.2K 1/4W	R565	ERDS2TJ102T	1K 1/4W	R637	ERG1SJ101E	100 1W ▲
R405	ERDS2TJ102T	1K 1/4W	R502	ERDS2TJ222T	2.2K 1/4W	R566	ERDS2TJ102T	1K 1/4W	R638	ERG1SJ101E	100 1W ▲
R406	ERDS2TJ102T	1K 1/4W	R508	ERDS1FVJ2R2T	2.2 1/2W ▲	R583	ERDS2TJ102T	1K 1/4W	R639	ERG1SJ101E	100 1W ▲
R407	ERDS2TJ102T	1K 1/4W	R511	ERDS2TJ471T	470 1/4W	R584	ERDS2TJ102T	1K 1/4W	R640	ERG1SJ101E	100 1W ▲
R408	ERDS2TJ102T	1K 1/4W	R512	ERDS2TJ471T	470 1/4W	R585	ERDS2TJ102T	1K 1/4W	R641	ERDS2TJ684T	680K 1/4W
R409	ERDS2TJ102T	1K 1/4W	R513	ERDS2TJ474T	470K 1/4W	R586	ERDS2TJ102T	1K 1/4W	R642	ERDS2TJ224T	220K 1/4W
R410	ERDS2TJ102T	1K 1/4W	R514	ERDS2TJ474T	470K 1/4W	R587	ERDS2TJ102T	1K 1/4W	R643	ERDS2TJ102T	1K 1/4W
R411	ERDS2TJ102T	1K 1/4W	R515	ERDS2TJ474T	470K 1/4W	R588	ERDS2TJ102T	1K 1/4W	R647	ERDS2TJ221T	220 1/4W
R412	ERDS2TJ102T	1K 1/4W	R516	ERDS2TJ474T	470K 1/4W	R589	ERDS2TJ392T	3.9K 1/4W	R648	ERDS2TJ221T	220 1/4W
R413	ERDS2TJ102T	1K 1/4W	R517	ERDS2TJ332T	3.3K 1/4W	R590	ERDS2TJ473T	47K 1/4W	R651	ERDS2TJ102T	1K 1/4W
R414	ERDS2TJ102T	1K 1/4W	R518	ERDS2TJ332T	3.3K 1/4W	R591	ERDS2TJ222T	2.2K 1/4W	R652	ERDS2TJ102T	1K 1/4W
R415	ERDS2TJ102T	1K 1/4W	R519	ERDS2TJ182T	1.8K 1/4W	R592	ERDS2TJ222T	2.2K 1/4W	R653	ERDS2TJ563T	56K 1/4W
R416	ERDS2TJ102T	1K 1/4W	R520	ERDS2TJ182T	1.8K 1/4W	R601	ERDS2TJ102T	1K 1/4W	R654	ERDS2TJ563T	56K 1/4W
R417	ERDS2TJ473T	47K 1/4W	R521	ERDS2TJ223T	22K 1/4W	R602	ERDS2TJ102T	1K 1/4W	R655	ERDS2TJ182T	1.8K 1/4W
R418	ERDS2TJ473T	47K 1/4W	R522	ERDS2TJ223T	22K 1/4W	R603	ERDS2TJ563T	56K 1/4W	R656	ERDS2TJ182T	1.8K 1/4W
R419	ERDS2TJ104T	100K 1/4W	R523	ERDS2TJ392T	3.9K 1/4W	R604	ERDS2TJ563T	56K 1/4W	R657	ERDS2TJ563T	56K 1/4W
R420	ERDS2TJ104T	100K 1/4W	R524	ERDS2TJ392T	3.9K 1/4W	R605	ERDS2TJ182T	1.8K 1/4W	R658	ERDS2TJ563T	56K 1/4W
R421	ERDS2TJ104T	100K 1/4W	R525	ERDS2TJ222T	2.2K 1/4W	R606	ERDS2TJ182T	1.8K 1/4W	R659	ERDS2TJ470T	47 1/4W
R422	ERDS2TJ104T	100K 1/4W	R526	ERDS2TJ222T	2.2K 1/4W	R607	ERDS2TJ563T	56K 1/4W	R660	ERDS2TJ470T	47 1/4W
R423	ERDS2TJ102T	1K 1/4W	R527	ERDS2TJ122T	1.2K 1/4W	R608	ERDS2TJ563T	56K 1/4W	R661	ERDS1FVJ100T	10 1/2W ▲
R424	ERDS2TJ102T	1K 1/4W	R528	ERDS2TJ122T	1.2K 1/4W	R609	ERDS2TJ470T	47 1/4W	R662	ERDS1FVJ100T	10 1/2W ▲
R425	ERDS2TJ103T	10K 1/4W	R529	ERDS2TJ273T	27K 1/4W	R610	ERDS2TJ470T	47 1/4W	R663	ERDS2TJ102T	1K 1/4W

Ref No.	Part No.	Values & Remarks	Ref No.	Part No.	Values & Remarks	Ref No.	Part No.	Values & Remarks	Ref No.	Part No.	Values & Remarks
R664	ERDS2TJ102T	1K 1/4W	R717	ERDS1FVJ3R3T	3.3 1/2W	R930	ERDS2TJ101T	100 1/4W	R1056	ERDS2TJ153T	15K 1/4W
R665	ERDS2TJ154T	150K 1/4W	R718	ERDS1FVJ3R3T	3.3 1/2W	R941	ERDS2TJ472T	4.7K 1/4W	R1061	ERDS2TJ222T	2.2K 1/4W
R666	ERDS2TJ184T	180K 1/4W	R719	ERDS1FVJ3R3T	3.3 1/2W	R946	ERDS2TJ103T	10K 1/4W	R1062	ERDS2TJ273T	27K 1/4W
R667	ERDS2TJ473T	47K 1/4W	R720	ERDS1FVJ3R3T	3.3 1/2W	R947	ERDS2TJ103T	10K 1/4W	R1063	ERDS2TJ332T	3.3K 1/4W
R668	ERDS2TJ473T	47K 1/4W	R721	ERD25FVJ331T	330 1/4W	R948	ERDS2TJ103T	10K 1/4W	R1081	ERDS2TJ104T	100K 1/4W
R669	ERDS2TJ223T	22K 1/4W	R722	ERDS2TJ123T	12K 1/4W	R949	ERDS2TJ103T	10K 1/4W	R1082	ERDS2TJ474T	470K 1/4W
R670	ERD25FVJ220T	22 1/4W	R723	ERDS1FVJ100T	10 1/2W	R950	ERDS2TJ102T	1K 1/4W			
R671	ERDS2TJ473T	47K 1/4W	R724	ERDS1FVJ100T	10 1/2W	R951	ERDS2TJ122T	1.2K 1/4W			CAPACITORS
R672	ERDS2TJ274T	270K 1/4W	R725	ERDS2TJ681T	680 1/4W	R952	ERDS2TJ152T	1.5K 1/4W			
R673	ERDS2TJ684T	680K 1/4W	R726	ERD25FVJ331T	330 1/4W	R953	ERDS2TJ182T	1.8K 1/4W	C1	ECKR1H473ZF5	0.047 50V
R674	ERDS2TJ563T	56K 1/4W	R727	ERD25FVJ331T	330 1/4W	R954	ERDS2TJ222T	2.2K 1/4W	C2	ECKR1H473ZF5	0.047 50V
R675	ERDS2TJ563T	56K 1/4W	R730	ERDS1FVJ4R7T	4.7 1/2W	R955	ERDS2TJ332T	3.3K 1/4W	C101	ECBT1C103NS5	0.01 16V
R676	ERDS2TJ682T	6.8K 1/4W	R754	ERDS2TJ102T	1K 1/4W	R956	ERDS2TJ472T	4.7K 1/4W	C103	ECBT1C103NS5	0.01 16V
R677	ERDS2TJ222T	2.2K 1/4W	R772	ERDS2TJ104T	100K 1/4W	R957	ERDS2TJ682T	6.8K 1/4W	C104	ECBT1H102KB5	1000P 50V
R678	ERD2FCVG391T	390 1/4W(MAV)	R773	ERDS2TJ103T	10K 1/4W	R958	ERDS2TJ123T	12K 1/4W	C105	ECBT1H470J5	47P 50V
R679	ERD25FVJ470T	47 1/4W	R774	ERDS2TJ223T	22K 1/4W	R960	ERDS2TJ102T	1K 1/4W	C106	ECBT1C103NS5	0.01 16V
R680	ERD25FVJ470T	47 1/4W	R775	ERDS2TJ472T	4.7K 1/4W	R961	ERDS2TJ122T	1.2K 1/4W	C107	ECBT1H473ZF5	0.047 50V
R681	ERDS2TJ270T	27 1/4W	R777	ERDS2TJ220T	22 1/4W	R962	ERDS2TJ152T	1.5K 1/4W	C108	ECBT1H100JC5	10P 50V(EB)(E)
R682	ERDS2TJ270T	27 1/4W	R778	ERDS2TJ222T	2.2K 1/4W	R963	ERDS2TJ182T	1.8K 1/4W	C108	ECBT1H8R2KC5	8.2P 50V EG
R683	ERDS2TJ270T	27 1/4W	R779	ERDS2TJ103T	10K 1/4W	R964	ERDS2TJ222T	2.2K 1/4W	C109	ECBT1C103NS5	0.01 16V
R684	ERDS2TJ270T	27 1/4W	R780	ERDS2TJ473T	47K 1/4W	R970	ERDS2TJ102T	1K 1/4W	C110	ECBT1C103NS5	0.01 16V
R685	ERDS2TJ270T	27 1/4W	R781	ERDS2TJ473T	47K 1/4W	R971	ERDS2TJ122T	1.2K 1/4W	C111	ECEA1EKA4R7B	4.7 25V
R686	ERDS2TJ270T	27 1/4W	R782	ERDS2TJ153T	15K 1/4W	R972	ERDS2TJ152T	1.5K 1/4W	C112	ECBT1C103NS5	0.01 16V
R687	ERDS2TJ270T	27 1/4W	R783	ERDS2TJ103T	10K 1/4W	R973	ERDS2TJ182T	1.8K 1/4W	C113	ECBT1H102KB5	1000P 50V
R688	ERDS2TJ270T	27 1/4W	R784	ERDS2TJ335T	3.3M 1/4W	R974	ERDS2TJ222T	2.2K 1/4W	C114	ECEA1HKA3R3B	3.3 50V
R689	ERDS2TJ270T	27 1/4W	R791	ERDS2TJ223T	22K 1/4W	R980	ERDS2TJ102T	1K 1/4W	C115	ECEA1EKA4R7B	4.7 25V
R690	ERDS2TJ270T	27 1/4W	R792	ERDS2TJ223T	22K 1/4W	R981	ERDS2TJ122T	1.2K 1/4W	C116	ECBT1C822MS5	8200P 16V
R691	ERDS2TJ270T	27 1/4W	R795	ERDS2TJ223T	22K 1/4W	R982	ERDS2TJ152T	1.5K 1/4W	C117	ECQB1H471JF3	470P 50V
R692	ERDS2TJ270T	27 1/4W	R796	ERDS2TJ223T	22K 1/4W	R983	ERDS2TJ182T	1.8K 1/4W	C118	ECQB1H103JF3	0.01 50V
R693	ERDS2TJ270T	27 1/4W	R797	ERDS2TJ682T	6.8K 1/4W	R984	ERDS2TJ222T	2.2K 1/4W	C119	ECQB1H103JF3	0.01 50V
R694	ERDS2TJ270T	27 1/4W	R901	ERDS2TJ102T	1K 1/4W	R985	ERDS2TJ822T	8.2K 1/4W	C120	ECEA1HKA010B	1 50V
R695	ERDS2TJ102T	1K 1/4W	R906	ERDS2TJ104T	100K 1/4W	R1001	ERDS2TJ102T	1K 1/4W	C121	ECEA1HKA010B	1 50V
R696	ERDS2TJ102T	1K 1/4W	R907	ERDS2TJ104T	100K 1/4W	R1002	ERDS2TJ102T	1K 1/4W	C122	ECEA1HKA2R2B	2.2 50V
R697	ERDS2TJ221T	220 1/4W	R908	ERDS2TJ104T	100K 1/4W	R1003	ERDS2TJ102T	1K 1/4W	C123	ECEA1HKA010B	1 50V
R698	ERDS2TJ221T	220 1/4W	R909	ERDS2TJ104T	100K 1/4W	R1004	ERDS2TJ102T	1K 1/4W	C124	ECBT1H102KB5	1000P 50V
R699	ERDS2TJ332T	3.3K 1/4W	R910	ERDS2TJ102T	1K 1/4W	R1005	ERDS2TJ203T	20K 1/4W	C125	ECBT1H150JC5	15P 50V
R703	ERDS1FVJ3R9T	3.9 1/2W	R911	ERDS2TJ104T	100K 1/4W	R1007	ERDS2TJ473T	47K 1/4W	C126	ECBT1H104ZF5	0.1 50V
R704	ERDS1FVJ3R9T	3.9 1/2W	R912	ERDS2TJ103T	10K 1/4W	R1008	ERDS2TJ473T	47K 1/4W	C127	ECEA1CKA220B	22 16V
R705	ERDS2TJ472T	4.7K 1/4W	R914	ERDS2TJ274T	270K 1/4W	R1009	ERDS2TJ332T	3.3K 1/4W	C128	ECBT1C103NS5	0.01 16V
R706	ERDS2TJ102T	1K 1/4W	R917	ERDS2TJ103T	10K 1/4W	R1010	ERDS2TJ332T	3.3K 1/4W	C129	ECEA0JKA101B	100 6.3V
R707	ERD25FVJ221T	220 1/4W	R920	ERDS2TJ271T	270 1/4W	R1011	ERDS2TJ332T	3.3K 1/4W	C130	ECEA0JKA101B	100 6.3V
R708	ERDS2TJ472T	4.7K 1/4W	R921	ERDS2TJ121T	120 1/4W	R1012	ERDS2TJ102T	1K 1/4W	C131	ECBT1C103NS5	0.01 16V
R709	ERDS2TJ1R5T	1.5 1/4W	R922	ERDS2TJ472T	4.7K 1/4W	R1013	ERDS2TJ103T	10K 1/4W	C132	ECBT1H102KB5	1000P 50V
R710	ERDS2TJ1R5T	1.5 1/4W	R923	ERDS2TJ104T	100K 1/4W	R1014	ERDS2TJ104T	100K 1/4W	C133	ECBT1H150JC5	15P 50V
R711	ERDS2TJ752T	7.5K 1/4W	R924	ERDS2TJ333T	33K 1/4W	R1051	ERDS2TJ393T	39K 1/4W	C134	ECBT1H180JC5	18P 50V
R712	ERDS2TJ682T	6.8K 1/4W	R927	ERDS2TJ181T	180 1/4W	R1052	ERDS2TJ105T	1M 1/4W	C135	ECBT1C103MS5	0.01 16V
R715	ERDS2TJ182T	1.8K 1/4W	R928	ERDS2TJ151T	150 1/4W	R1053	ERDS2TJ102T	1K 1/4W	C136	ECBT1C103MS5	0.01 16V
R716	ERD2FCVJ6R8T	6.8 1/4W	R929	ERDS2TJ101T	100 1/4W	R1055	ERDS2TJ224T	220K 1/4W	C137	ECBT1H561KB5	560P 50V

Ref No.	Part No.	Values & Remarks	Ref No.	Part No.	Values & Remarks	Ref No.	Part No.	Values & Remarks	Ref No.	Part No.	Values & Remarks
C138	ECBT1H561KB5	560P 50V	C421	ECBT1H331KB5	330P 50V	C526	ECQV1H683JZ3	0.068 50V	C635	ECKR1H103ZF5	0.01 50V
C139	ECQB1H682JF3	6800P 50V	C422	ECBT1H331KB5	330P 50V	C527	ECBT1C562KR5	5600P 16V	C636	ECKR1H103ZF5	0.01 50V
C140	ECQB1H682JF3	6800P 50V	C423	ECBT1H101KB5	100P 50V	C528	ECBT1C562KR5	5600P 16V	C637	ECKR1H223ZF5	0.022 50V
C141	ECEA1HKA010B	1 50V	C424	ECBT1H101KB5	100P 50V	C529	ECQB1H273JF3	0.027 50V	C638	ECKR1H223ZF5	0.022 50V
C142	ECEA1HKA010B	1 50V	C425	ECBT1H101KB5	100P 50V	C530	ECQB1H273JF3	0.027 50V	C641	ECEA1HKN010B	1 50V
C143	ECEA1HKA010B	1 50V	C426	ECBT1H101KB5	100P 50V	C531	ECBT1E103ZF5	0.01 25V	C642	ECEA1VKA4R7B	4.7 10V
C144	ECEA1HKA010B	1 50V	C427	ECBT1H221KB5	220P 50V	C532	ECBT1E103ZF5	0.01 25V	C643	ECBT1H101KB5	100P 50V
C145	ECBT1H220JC5	22P 50V	C428	ECBT1H221KB5	220P 50V	C533	ECEA1CKA220B	22 16V	C651	ECEA1HKN3R3B	3.3 50V
C146	ECBT1H331KB5	330P 50V	C431	ECEA1CU100B	10 16V	C534	ECEA1CKA220B	22 16V	C652	ECEA1HKN3R3B	3.3 50V
C147	ECBT1H102KB5	1000P 50V	C432	ECEA1CU100B	10 16V	C536	ECBT1E103ZF5	0.01 25V	C653	ECBT1H681KB5	680P 50V
C148	ECBT1C103NS5	0.01 16V	C440	ECBT1E103ZF5	0.01 25V	C537	ECEA1CU100B	10 16V	C654	ECBT1H681KB5	680P 50V
C149	ECBT1C103NS5	0.01 16V	C451	ECEA1VKA4R7B	4.7 10V	C538	ECEA1CU100B	10 16V	C655	ECEA1JU220B	22 63V
C150	ECBT1H104ZF5	0.1 50V	C452	ECEA1VKA4R7B	4.7 10V	C551	ECEA1HKA3R3B	3.3 50V	C656	ECEA1JU220B	22 63V
C172	ECBT1H331KB5	330P 50V	C453	ECBT1H100JC5	10P 50V	C552	ECEA1HKA3R3B	3.3 50V	C657	ECCR1H100K5	10P 50V
C173	ECEA1CKA220B	22 16V	C454	ECBT1H100JC5	10P 50V	C553	ECBT1H101KB5	100P 50V	C658	ECCR1H100K5	10P 50V
C174	ECEA1CKA101B	100 16V	C455	ECBT1H102KB5	1000P 50V	C554	ECBT1H101KB5	100P 50V	C659	ECBT1H221KB5	220P 50V
C175	ECBT1C103NS5	0.01 16V	C456	ECBT1H102KB5	1000P 50V	C555	ECBT1H221KB5	220P 50V	C660	ECBT1H221KB5	220P 50V
C176	ECBT1C103NS5	0.01 16V	C457	ECEA1AKA330B	33 10V	C556	ECBT1H221KB5	220P 50V	C661	ECQV1H473JZ3	0.047 50V
C181	ECBT1H471KB5	470P 50V	C458	ECEA1AKA330B	33 10V	C557	ECBT1E103ZF5	0.01 25V	C662	ECQV1H473JZ3	0.047 50V
C196	ECBT1H102KB5	1000P 50V	C459	ECFR1E223KR	0.022 25V	C558	ECBT1E103ZF5	0.01 25V	C663	ECBT1H681KB5	680P 50V
C351	ECEA1CKA220B	22 16V	C460	ECFR1E223KR	0.022 25V	C559	ECEA1CKA100B	10 16V	C664	ECBT1H681KB5	680P 50V
C352	ECEA1CKA220B	22 16V	C461	ECFR1E682KR	6800P 25V	C560	ECEA1CKA100B	10 16V	C665	ECEA1JU330	33 63V
C353	ECBT1H470J5	47P 50V	C462	ECFR1E682KR	6800P 25V	C563	ECBT1E103ZF5	0.01 25V	C666	ECEA2AU100B	10 100V
C354	ECBT1H470J5	47P 50V	C463	ECEA1VKA4R7B	4.7 10V	C583	ECEA0JKA470B	47 6.3V	C667	ECEA1JU220B	22 63V
C355	ECBT1E103ZF5	0.01 25V	C464	ECEA1VKA4R7B	4.7 10V	C584	ECEA0JKA470B	47 6.3V	C668	ECEA2AN2R2SB	2.2 100V
C356	ECBT1E103ZF5	0.01 25V	C465	ECBT1E103ZF5	0.01 25V	C601	ECEA1HKN3R3B	3.3 50V	C669	ECBT1H102KB5	1000P 50V
C357	ECEA0JKA470B	47 6.3V	C466	ECBT1E103ZF5	0.01 25V	C602	ECEA1HKN3R3B	3.3 50V	C671	ECEA2AU100B	10 100V
C358	ECEA0JKA470B	47 6.3V	C469	ECBT1H181KB5	180P 50V	C603	ECBT1H681KB5	680P 50V	C672	ECEA2AU100B	10 100V
C359	ECBT1E103ZF5	0.01 25V	C470	ECBT1H181KB5	180P 50V	C604	ECBT1H681KB5	680P 50V	C681	ECEA1HN100SB	10 50V
C360	ECBT1E103ZF5	0.01 25V	C503	ECEA0JKA101B	100 6.3V	C605	ECEA1JU220B	22 63V	C682	ECEA1HN100SB	10 50V
C401	ECEA1VKA4R7B	4.7 10V	C504	ECEA0JKA101B	100 6.3V	C606	ECEA1JU220B	22 63V	C683	ECBT1C332KR5	3300P 16V
C402	ECEA1VKA4R7B	4.7 10V	C505	ECFR1C104MR	0.1 16V	C607	ECCR1H100K5	10P 50V	C684	ECBT1C332KR5	3300P 16V
C403	ECBT1E103ZF5	0.01 25V	C506	ECFR1C104MR	0.1 16V	C608	ECCR1H100K5	10P 50V	C685	ECBT1E103ZF5	0.01 25V
C404	ECBT1E103ZF5	0.01 25V	C511	ECEA1HKA3R3B	3.3 50V	C609	ECBT1H221KB5	220P 50V	C701	ECBT1E103ZF5	0.01 25V
C405	ECBT1H101KB5	100P 50V	C512	ECEA1HKA3R3B	3.3 50V	C610	ECBT1H221KB5	220P 50V	C702	ECQE2104KF3	0.1 1
C406	ECBT1H101KB5	100P 50V	C513	ECBT1H150J5	15P 50V	C611	ECQV1H473JZ3	0.047 50V	C703	ECES75V752UX	7500 100V 
C409	ECEA1EKA220B	22 25V	C514	ECBT1H150J5	15P 50V	C612	ECQV1H473JZ3	0.047 50V	C704	ECES75V752UX	7500 100V 
C410	ECEA1EKA220B	22 25V	C515	ECBT1H221KB5	220P 50V	C613	ECBT1H681KB5	680P 50V	C705	ECEA1HM332EV	3300P 50V [M]
C411	ECBT1H101KB5	100P 50V	C516	ECBT1H221KB5	220P 50V	C614	ECBT1H681KB5	680P 50V	C706	ECEA1HM332EV	3300P 50V [M]
C412	ECBT1H101KB5	100P 50V	C517	ECBT1H330J5	33P 50V	C615	ECEA1JU330	33 63V	C707	ECA1VM101B	100P 10V
C413	ECEA1CU100B	10 16V	C518	ECBT1H330J5	33P 50V	C616	ECEA2AU100B	10 100V	C708	ECKR1H103ZF5	0.01 50V
C414	ECEA1CU100B	10 16V	C519	ECEA1VKA4R7B	4.7 10V	C617	ECEA1JU220B	22 63V	C709	ECEA1CKA330B	33 16V
C415	ECBT1E103ZF5	0.01 25V	C520	ECEA1VKA4R7B	4.7 10V	C618	ECEA2AN2R2SB	2.2 100V	C710	ECBT1E103ZF5	0.01 25V
C416	ECBT1E103ZF5	0.01 25V	C521	ECEA1VKA4R7B	4.7 10V	C619	ECBT1H102KB5	1000P 50V	C711	ECKR1H103ZF5	0.01 50V
C417	ECBT1H101KB5	100P 50V	C522	ECEA1VKA4R7B	4.7 10V	C621	ECEA2AU100B	10 100V	C712	ECEA1HKA100B	10 50V
C418	ECBT1H101KB5	100P 50V	C523	ECFR1E123KR	0.012 25V	C622	ECEA2AU100B	10 100V	C713	ECBT1E103ZF5	0.01 25V
C419	ECBT1H331KB5	330P 50V	C524	ECFR1E123KR	0.012 25V	C631	ECKR1H223ZF5	0.022 50V	C714	ECEA1EKA470B	47 25V
C420	ECBT1H331KB5	330P 50V	C525	ECQV1H683JZ3	0.068 50V	C632	ECKR1H223ZF5	0.022 50V	C715	ECEA1CKA101B	100 16V

Ref No	Part No.	Values & Remarks	Ref No.	Part No.	Values & Remarks	Ref No.	Part No.	Values & Remarks	Ref No.	Part No.	Values & Remarks
C721	ECQE2104KF3	0.1 1	C921	ECBT1H331KB5	330P 50V	C1009	ECEA0JU221B	220 6.3V	C1037	ECBT1H101KB5	100P 50V
C751	ECKWRS102MBC	0.001 400V(MAV) 	C922	ECBT1H331KB5	330P 50V	C1010	ECEA1CKA100B	10 16V	C1038	ECBT1H101KB5	100P 50V
C752	ECKR1H103ZF5	0.01 50V	C923	ECBT1H331KB5	330P 50V	C1011	ECEA1CKA100B	10 16V	C1039	ECEA1CU101B	100 16V
C753	ECA1EM102B	1000P 25V	C924	ECBT1H331KB5	330P 50V	C1012	ECEA1CKA100B	10 16V	C1040	ECEA1CKA100B	10 16V
C754	ECBT1E103ZF5	0.01 25V	C925	ECBT1H331KB5	330P 50V	C1013	ECEA1CKA100B	10 16V	C1041	ECBT1E103ZF5	0.01 25V
C755	ECEA1CU470B	47 16V	C926	ECBT1H331KB5	330P 50V	C1014	ECEA0JU221B	220 6.3V	C1043	ECEA1CKA100B	10 16V
C757	ECEA1CU100B	10 16V	C927	ECBT1H331KB5	330P 50V	C1015	ECQV1H104JZ3	0.1 50V	C1044	ECEA1CKA100B	10 16V
C758	ECEA1AU101B	100 10V	C928	ECBT1H331KB5	330P 50V	C1016	ECQV1H104JZ3	0.1 50V	C1051	ECEA1HKA2R2B	2.2 50V
C771	ECEA1HKA2R2B	2.2 50V	C929	ECBT1H331KB5	330P 50V	C1017	ECEA1HKAR47B	0.47 50V	C1052	ECEA1HKA010B	1 50V
C772	ECEA1CU100B	10 16V	C930	ECBT1H331KB5	330P 50V	C1018	ECEA1HKA4R7B	4.7 50V	C1053	ECEA1HKA3R3B	3.3 50V
C773	ECBT1E223ZF5	0.022 25V	C931	ECBT1H101KB5	100P 50V	C1019	ECEA1HKAR47B	0.47 50V	C1054	ECEA0JU221B	220 6.3V
C774	ECEA0JU221B	220 6.3V	C934	ECBT1H101KB5	100P 50V	C1020	ECEA1HKA4R7B	4.7 50V	C1055	ECEA1HKA010B	1 50V
C901	ECEA0JU102B	1000 6.3V	C935	ECBT1E103ZF5	0.01 25V	C1021	ECEA1HKAR15B	0.15 50V	C1056	ECFR1E563KR	0.056 25V
C902	ECBT1E223ZF5	0.022 25V	C936	ECBT1H101KB5	100P 50V	C1022	ECEA1HKA3R3B	3.3 50V	C1057	ECFR1E152KR	1500P 25V
C903	ECBT1E103ZF5	0.01 25V	C938	ECBT1H101KB5	100P 50V	C1023	ECQV1H154JZ3	0.15 50V	C1058	ECFR1E563KR	0.056 25V
C904	ECEA0JU102B	1000 6.3V	C944	ECBT1E103ZF5	0.01 25V	C1024	ECQV1H154JZ3	0.15 50V	C1059	ECEA1CKA101B	100 16V
C906	ECEA0JKA101B	100 6.3V	C948	ECBT1E103ZF5	0.01 25V	C1025	ECEA1HKA3R3B	3.3 50V	C1060	ECBT1E223ZF5	0.022 25V
C908	ECBT1E103ZF5	0.01 25V	C949	ECBT1H101KB5	100P 50V	C1026	ECEA1HKAR15B	0.15 50V	C1062	ECBT1E223ZF5	0.022 25V
C909	ECEA1VKA220B	22 10V	C994	ECBT1H101KB5	100P 50V	C1027	ECEA1HKA4R7B	4.7 50V	C1063	ECEA1CKA101B	100 16V
C910	ECEA1VKA220B	22 10V	C995	ECBT1H101KB5	100P 50V	C1028	ECEA1HKAR47B	0.47 50V	C1064	ECEA1HKA010B	1 50V
C911	ECEA1VKA220B	22 10V	C996	ECBT1H101KB5	100P 50V	C1029	ECEA1HKA4R7B	4.7 50V	C1065	ECBT1H681KB5	680P 50V
C912	ECEA1VKA220B	22 10V	C1001	ECEA1HKA010B	1 50V	C1030	ECEA1HKAR47B	0.47 50V	C1067	ECBT1C152KR5	1500P 16V
C913	ECEA1VKA100B	10 10V	C1002	ECEA1HKA010B	1 50V	C1031	ECQV1H104JZ3	0.1 50V	C1068	ECBT1C152KR5	1500P 16V
C914	ECEA1VKA100B	10 10V	C1003	ECEA1HKA3R3B	3.3 50V	C1032	ECQV1H104JZ3	0.1 50V	C1081	ECEA1HKA010B	1 50V
C916	ECEA1HKA010B	1 50V	C1004	ECEA1HKA3R3B	3.3 50V	C1033	ECEA0JKA470B	47 6.3V	C1082	ECBT1E223ZF5	0.022 25V
C917	ECEA1HKAR47B	0.47 50V	C1005	ECEA1HKA010B	1 50V	C1034	ECQV1H474JZ3	0.47 50V			
C918	ECEA0JKA221B	220 6.3V	C1007	ECFR1E223KR	0.022 25V	C1035	ECBT1H681KB5	680P 50V			
C920	ECEA1HKA010B	1 50V	C1008	ECFR1E473KR	0.047 25V	C1036	ECBT1H101KB5	100P 50V			

■ **Packaging** (Refer to page 47 for the Parts List.)

ACCESSORY

P1 (SPSD152)	: ACCESSORY BOX
A1 (RAK-SA612WHP)	: REMOTE CONTROL UNIT
A2 (RSA0010)	: AM LOOP ANT
A3 (VJA0733)...EB	: AC CORD
A3 (RJA0019-2K)...E,EG	: AC CORD
A4 (RSA0007)	: FM ANTENNA
A5 (RFKSAEX500EK)...E	: INSTR. MANUAL ASS'Y
A5 (RFKSAEX500EB)...EB	: INSTR. MANUAL ASS'Y
A5 (RFKSAEX500EG)...EG	: INSTR. MANUAL ASS'Y
A6 (SJP9009)...EB	: ANT. ADAPTOR

