

Service Manual

AV Control Stereo Receiver

Receiver

SA-EX800

Simplified

DOLBY SURROUND
PRO • LOGIC

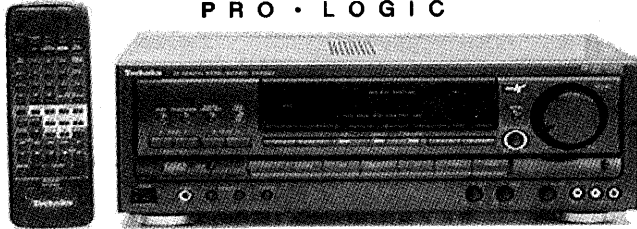

Colour

(K) Black Type

Area

Suffix for Model No.	Area	Colour
(P)	U.S.A.	(K)

* Manufactured under license from Dolby Laboratories Licensing Corporation. Additionally licensed under one or more of the following patents:
U.S. numbers 3,632,886, 3,746,792 and 3,959,590; Canada numbers 1,004,603 and 1,037,877.
"Dolby" and the double-D symbol are trademarks of Dolby Laboratories Licensing Corporation.

Please file and use this manual together with the Service Manual for Model No. SA-EX900P/PC-K, Order No : MD9605030C1.

Note : • This Simplified Service Manual is provided to indicate the main differences between the original model no. SA-EX900(P) and the subsequent model SA-EX800 (P).

CHANGES

■ Parts Comparison Table

Notes :1.Important safety notice :

Component identified by Δ mark have special characteristics important for safety.

Furthermore, special parts which have purpose of fire-retardant (resistors), high quality sound (capacitors), low noise (resistors), etc. are used.
When replacing any of these components, be sure to use only manufacturer's specified parts shown in the parts list.

2. [MAV] Indicates parts that are supplied by MAV.

Ref. No.	Description	Change of Parts Number		Remarks
		SA-EX900 (P) (Original)	SA-EX800 (P)	
CABINET AND CHASSIS				
2	BACK PANEL	RGR0239A-E [MAV]	RGR0239A-G [MAV]	Changed
12	MODE BUTTON	RGU1350B-K [MAV]	RGU1350C-K	Changed
16	FRONT PANEL ASS'Y	RFKGEX900PK [MAV]	RFKGAEX800PK [MAV]	Changed
27	LED SUPPORT	_____	RMN0385 [MAV]	Added
29	DOLBY BUTTON	RGU1352-K [MAV]	RGU1352E-K [MAV]	Changed
31	SFC BUTTON	_____	RGU1397-Q [MAV]	Added
33	LED COVER	_____	RMV0113 [MAV]	Added
TRANSISTORS				
Q931	TRANSISTOR	_____	RVTDTTC114YST	Added
Q933	TRANSISTOR	_____	RVTDTTC114YST	Added
Q935	TRANSISTOR	_____	RVTDTTC114YST	Added
DIODE				
D905	DIODE	MA167ATA	_____	Deleted

⚠ WARNING

This service information is designed for experience repair technicians only and is not designed for use by the general public. It does not contain warnings or cautions to advise non-technical individuals of potential dangers in attempting to service a product. Products powered by electricity should be serviced or repaired only by experienced professional technicians. Any attempt to service or repair the product or products dealt with in this service information by anyone else could result in serious injury or death.

© 1996 Matsushita Electronics (S) Pte. Ltd..
All rights reserved. Unauthorized copying and distribution is a violation of law.

Technics®

Ref. No.	Description	Change of Parts Number		Remarks
		SA-EX900 (P) (Original)	SA-EX800 (P)	
D931	LED	_____	LN440YCPUVT1 [MAV]	Added
D933	LED	_____	LN440YCPUVT1 [MAV]	Added
D935	LED	_____	LN440YCPUVT1 [MAV]	Added
SWITCHES				
S955	SW, SLEEP	_____	EVQ21405R	Added
S971	SW, THEATER	EVQ21405R	_____	Deleted
S973	SW, CLUB	EVQ21405R	_____	Deleted
PACKING MATERIALS				
P2	PACKING CASE	RPG2919 [MAV]	RPG2918 [MAV]	Changed
ACCESSORIES				
A5	INSTRUCTION MNL ASS'Y	RFKSEX900PK [MAV]	RFKSAEX800PK [MAV]	Changed
RESISTORS				
R931	RESISTOR 150Ω 1/4W	_____	ERDS2TJ151T	Added
R933	RESISTOR 150Ω 1/4W	_____	ERDS2TJ151T	Added
R935	RESISTOR 150Ω 1/4W	_____	ERDS2TJ151T	Added
CAPACITORS				
C954	CAPACITOR 0.01μF 25V	ECBT1E103ZF5	_____	Deleted

■ Cabinet Parts Differences

Note: These differences apply to "Operation Checks and Main Component Replacement Procedures" and "Cabinet Parts Location"

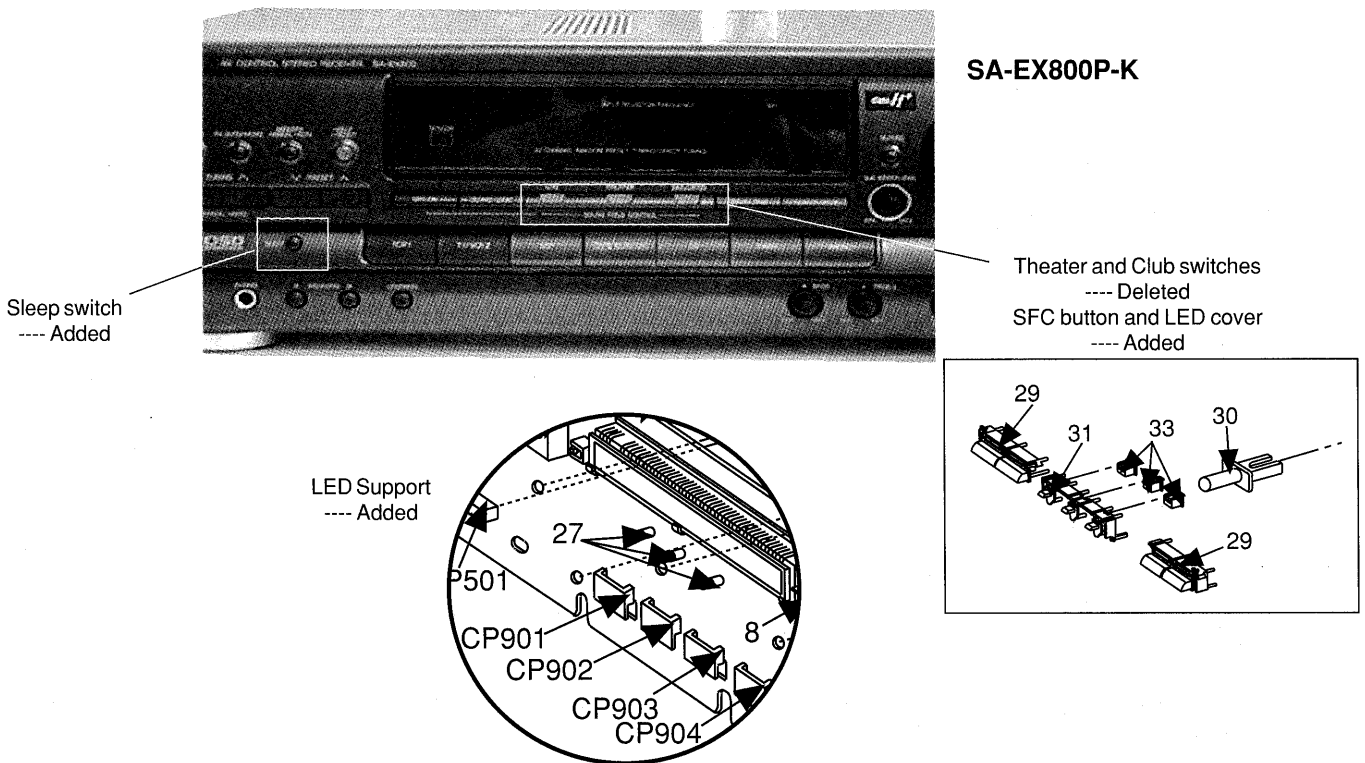

■ Printed Circuit Board

ⓓ POWER SWITCH P.C.B. (REP2327A-S ==> REP2329A-S)

ⓔ HEADPHONE JACK P.C.B. (REP2327A-S ==> REP2329A-S)

Ⓛ VCR2 INPUT P.C.B. (REP2327A-S ==> REP2329A-S)

Ⓒ VOLUME P.C.B. (REP2329A-S)

ⓑ PANEL P.C.B. (REP2329A-S)

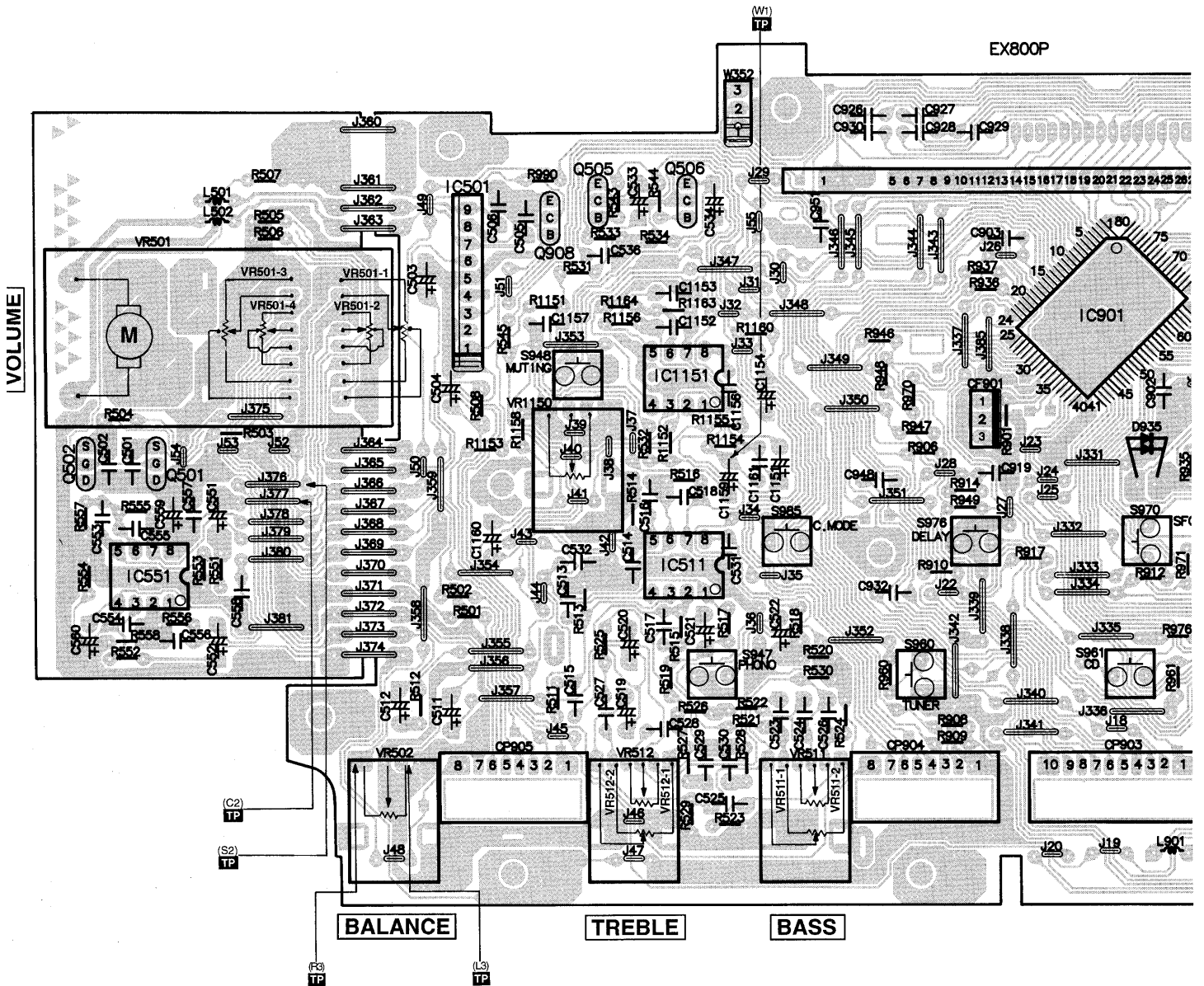

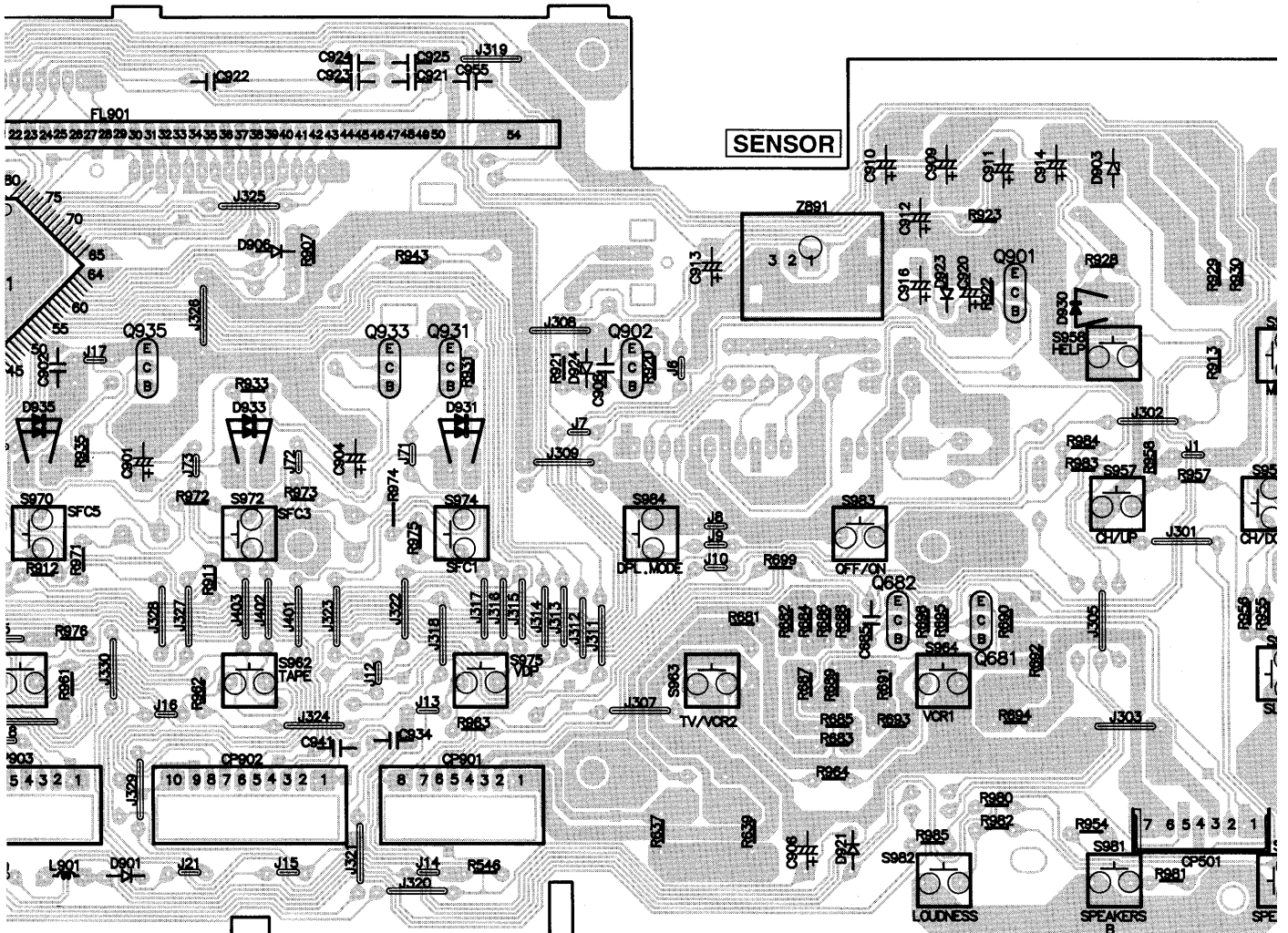

Schematic Diagram

B PANEL CIRCUIT

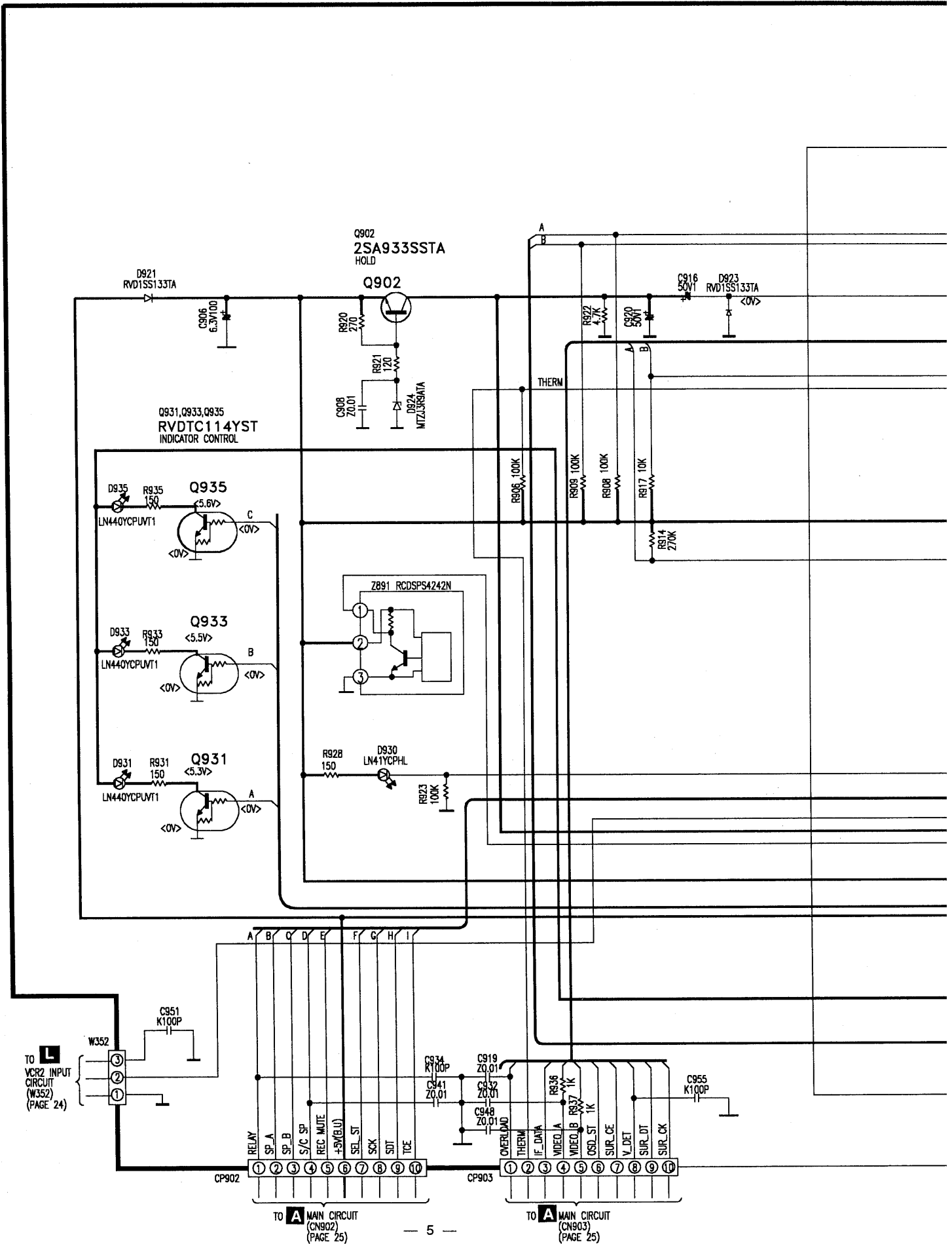

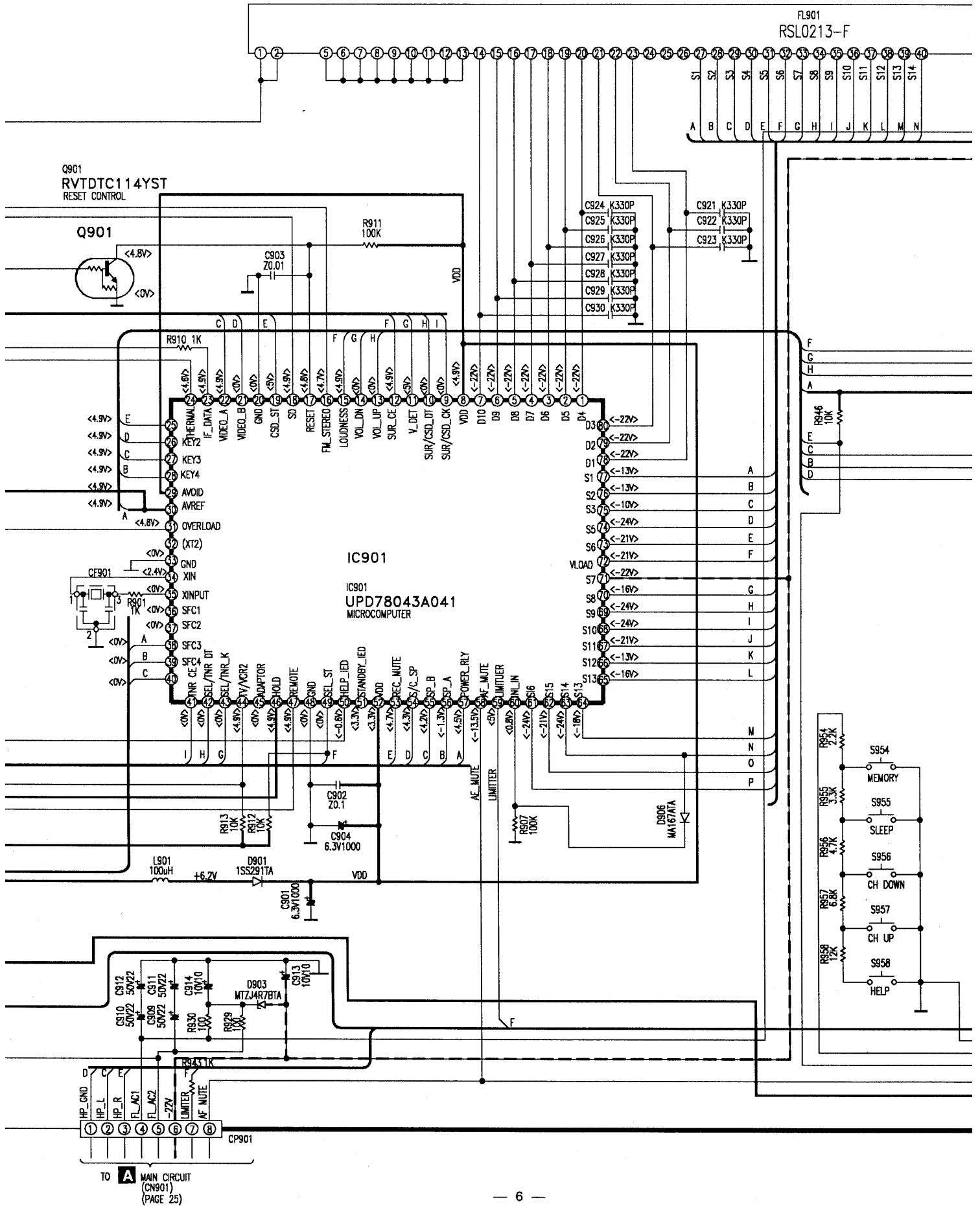

TO **A** MAIN CIRCUIT (CN901) (PAGE 25)

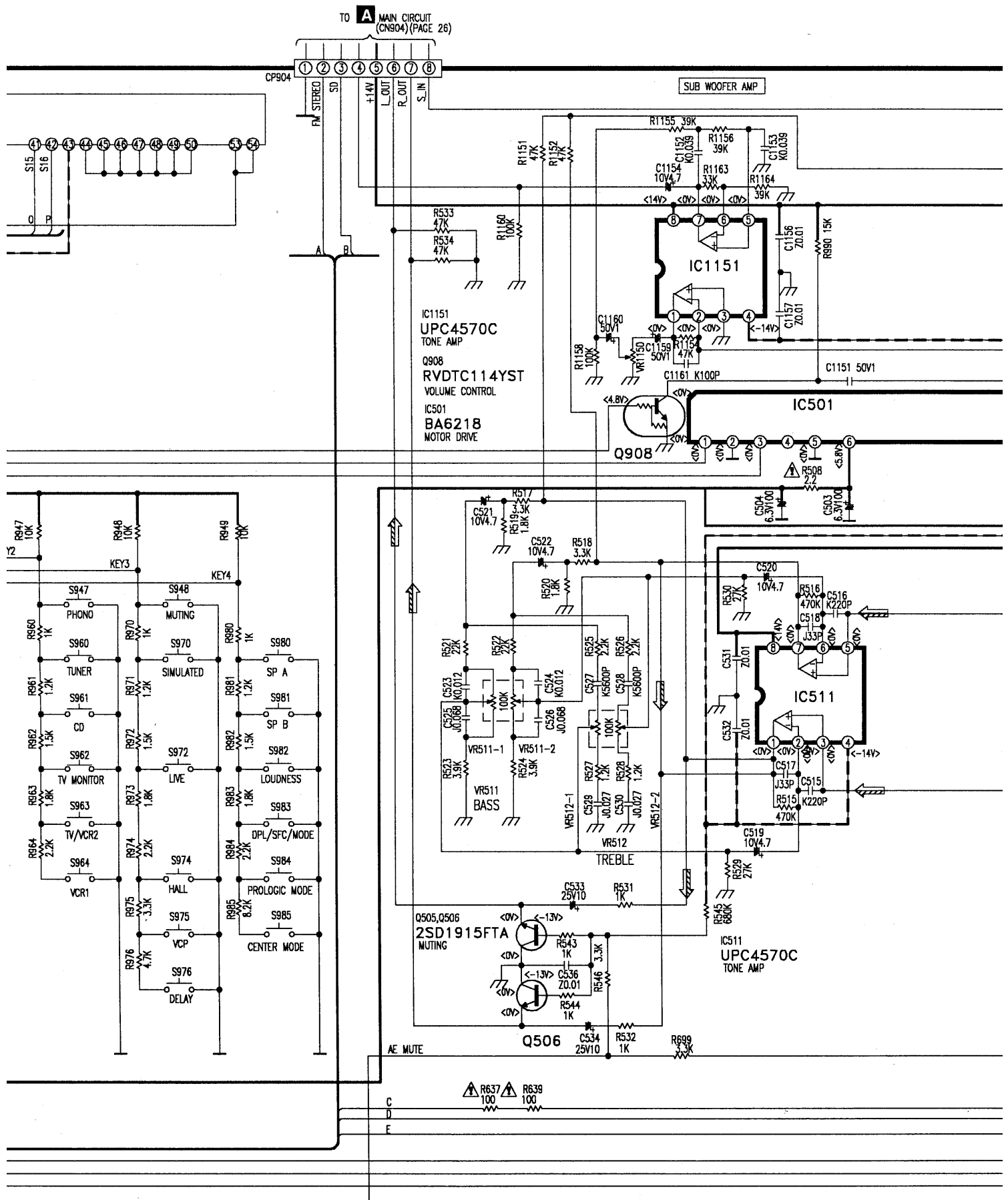

TO MAIN CIRCUIT (CN905) (PAGE 26)

C VOLUME CIRCUIT

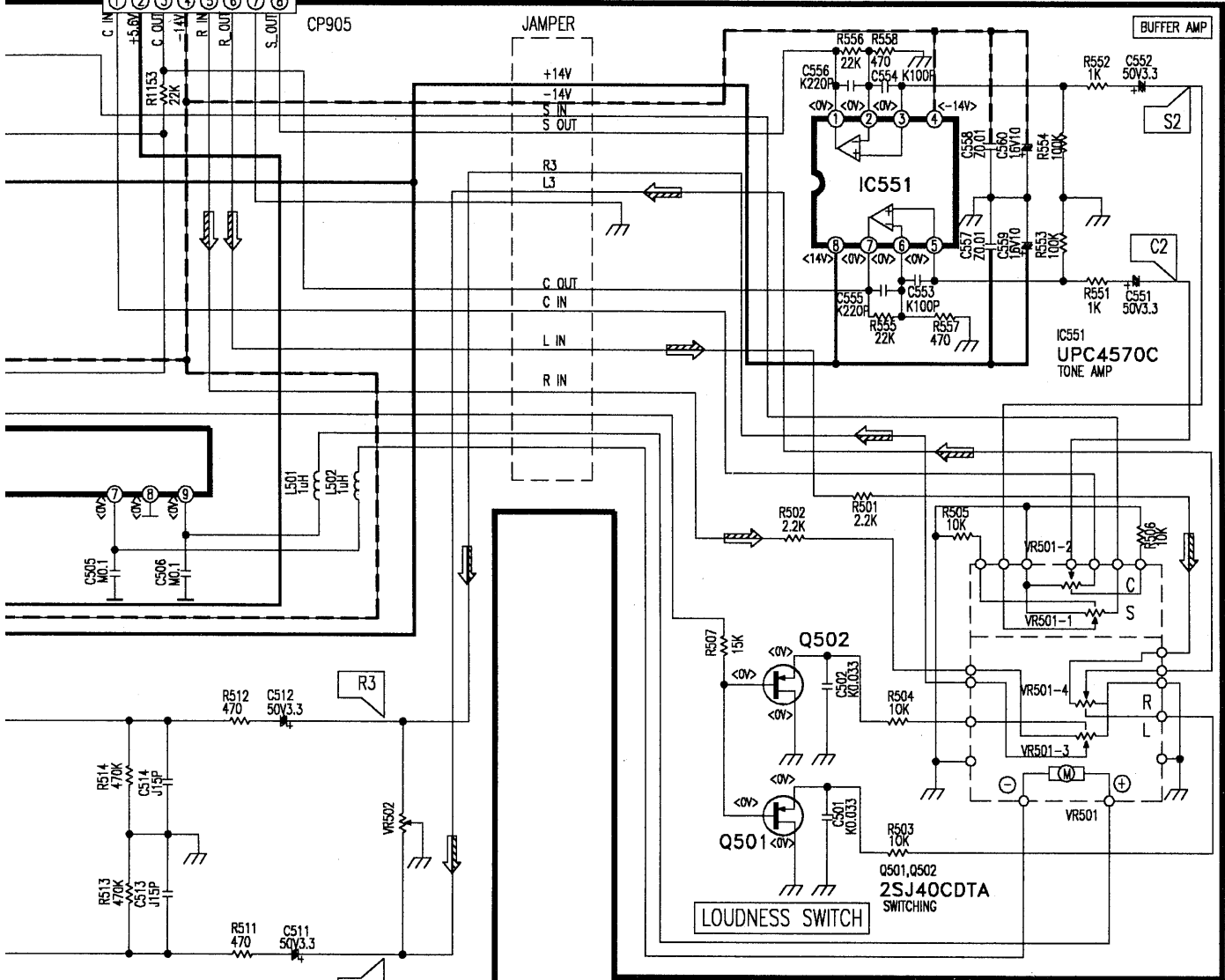

E HEADPHONE JACK CIRCUIT

D POWER SWITCH CIRCUIT

