

# Service Manual

AV Control Stereo Receiver

Receiver

## SA-G56

*Simplified*

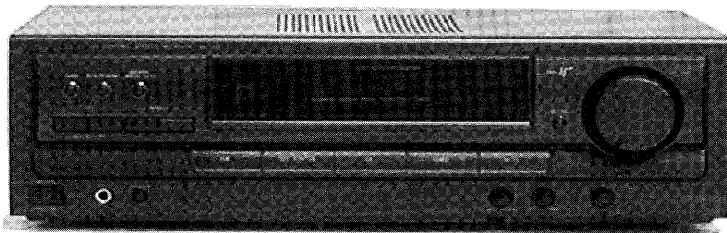

Colour

(K) ... Black Type

Area

Suffix for Model No.	Area	Colour
(PP)	U.S.A. and Canada	(K)

Please file and use this Service Manual together with the Service Manual for Model No. SA-EX100 (P/PC) Order No. MD9510121C1.

**Note :** This Simplified Service Manual is provided to indicate the main difference between the original Model No. SA-EX100 (P) and the subsequent Model No. SA-G56 (PP).

### CHANGES



## ■ SPECIFICATIONS

### ■ Amplifier Section

Rated minimum sine wave RMS power output	
40 Hz-20 kHz both channels driven	
0.8% total harmonic distortion	100W per channel (8Ω)
1 kHz continuous power output, both channels driven	
0.8% total harmonic distortion	103W per channel (8Ω)
Total harmonic distortion	
Rated power at 40 Hz - 20kHz	0.8% (8Ω)
Half power at 1 kHz	0.07% (8Ω)
Dynamic headroom	2dB (8Ω)
SMPTE intermodulation distortion	0.3% (8Ω)
Low frequency damping factor	30 (8Ω)
Load impedance	8Ω
Frequency response	
PHONO	RIAA standard curve ± 0.8dB
CD, VCR, TV, TAPE	10Hz - 70kHz, ± 3dB
Input sensitivity	
PHONO	0.4mV (3mV, IHF '66)
CD, VCR, TV, TAPE	27mV (200mV, IHF '66)
S/N (IHF A)	
PHONO	70dB (78dB, IHF '66)
CD, VCR, TV, TAPE	75dB (83dB, IHF '66)
Input impedance	
PHONO	47kΩ
CD, VCR, TV, TAPE	22kΩ
Tone control	
BASS	50Hz, +10 to -10dB
TREBLE	20kHz, +10 to -10dB

### ■ General

Dimensions (W x H x D)	430 x 136 x 309 mm (16 <sup>15</sup> / <sub>16</sub> " x 5 <sup>1</sup> / <sub>32</sub> " x 12 <sup>5</sup> / <sub>32</sub> " )
------------------------	--

**Notes :**

Specifications are subject to change without notice.  
Weight and dimensions shown are approximate.

### ■ Amplifier Section

Rated minimum sine wave RMS power output	
40 Hz-20 kHz both channels driven	
0.9% total harmonic distortion	100W per channel (8Ω)
1 kHz continuous power output, both channels driven	
0.9% total harmonic distortion	103W per channel (8Ω)
Total harmonic distortion	
Rated power at 40 Hz - 20kHz	0.9% (8Ω)
Half power at 1 kHz	0.07% (8Ω)
Dynamic headroom	2dB (8Ω)
SMPTE intermodulation distortion	0.9% (8Ω)
Low frequency damping factor	30 (8Ω)
Load impedance	8Ω
Frequency response	
PHONO	RIAA standard curve ± 0.8dB
CD, VCR, TAPE	10Hz - 60kHz, ± 3dB
Input sensitivity	
PHONO	0.4mV (3mV, IHF '66)
CD, VCR, TAPE	27mV (200mV, IHF '66)
S/N (IHF A)	
PHONO	70dB (78dB, IHF '66)
CD, VCR, TAPE	75dB (83dB, IHF '66)
Input impedance	
PHONO	47kΩ
CD, VCR, TAPE	22kΩ
Tone control	
BASS	50Hz, +10 to -10dB
TREBLE	20kHz, +10 to -10dB

### ■ General

Dimensions (W x H x D)	430 x 130.5 x 309 mm (16 <sup>15</sup> / <sub>16</sub> " x 5 <sup>1</sup> / <sub>8</sub> " x 12 <sup>5</sup> / <sub>32</sub> " )
------------------------	---

# Technics®

© 1996 Matsushita Electronics (S) Pte. Ltd.  
All rights reserved. Unauthorized copying and distribution is a violation of law.

**! WARNING**

This service information is designed for experienced repair technicians only and is not designed for use by the general public. It does not contain warnings or cautions to advise non-technical individuals of potential dangers in attempting to service a product. Products powered by electricity should be serviced or repaired only by experienced professional technicians. Any attempt to service or repair the product or products dealt with in this service information by anyone else could result in serious injury or death.

**Line up of Components**

Unit \ System Name	S075PC-K	S1750P-K
Amplifier (Made in MAV)	SA-G56PP-K	SA-G56PP-K
<b>Electronics Block (Made in MESA)</b>	<b>SD-S907PC-K</b>	<b>SD-S917P-K</b>
Cassette Deck (Made in MESA)		RS-TR180PP-K
CD Changer (Made in MESA)	SL-MC59PP-K	SL-MC59PP-K
Accessories Box (Made in MESA)	SH-WA07PC-K	SH-WA17P-K
Front Speaker (Made in MEP)	SB-A27PP-K	SB-A27PP-K
Rack (Made in MEP)	SH-KS17PC-K	SH-KS17P-K

**Replacement of the Fan Motor**

**Step 1**  
Release the 3 claws.

**Step 2**  
Put a screwdriver at the root of the fan and remove it.

**Step 3**  
Remove the fan cap.

**NOTE**  
When replacing the fan motor, align the boss of the fan case with the hole of the fan motor.

**Step 4**  
Desolder the wires from the motor terminal and replace it with a new one.

# Fan Motor Troubleshooting

The Model SA-EX500 employ fan motor error sensing electronics.

If the cooling fan is not operating and "OVER LOAD" is displayed on the FL display, check the fan motor and its driving circuit.

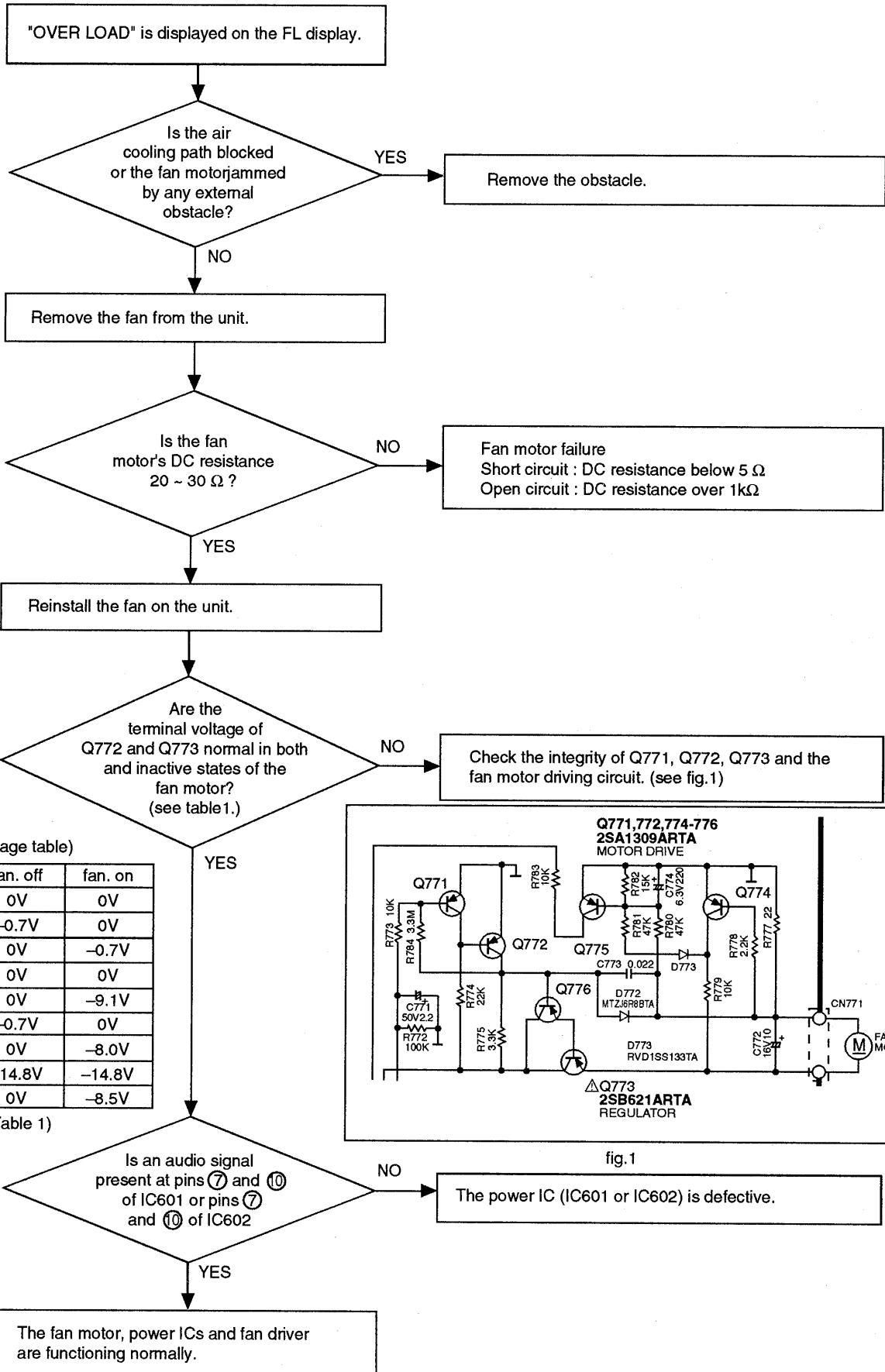

## Terminal Functions Of ICs

### • IC901 (UPD78043A041) System Microprocessor

Pin No.	Mark	I/O	Function
1~7	D4~D10	O	Digit signal of FL display
8	VDD	I	Power supply terminal
9	SUR/OSD_CK	-	Not used
10	SUR/OSD_DT	-	Not used
11	VIDEO_DET	-	Not used
12	SUR_CE	-	Not used
13	VOL_UP	O	Rotate control terminal of
14	VOL_DWN	O	volume motor
15	LOUDNESS	-	Not used
16	FM_STEREO	I	Stereo signal detect terminal
17	RESET	I	Reset detect terminal
18	SD	I	Received signal detect terminal
19	OSD_ST	-	Not used
20	GND	-	GND terminal
21	VIDEO_B	-	Not used
22	VIDEO_A	-	Not used
23	IF_DATA	I	Serial data signal
24	THERMAL	O	Mute control terminal
25~28	KEY1~KEY4	I	Key matrix detect terminal
29	AVDD	I	Power supply terminal
30	AVREF	I	Power supply terminal
31	OVERLOAD	I	Over load detect terminal
32	XT2	-	Not used
33	GND	-	GND terminal
34	XIN	I	Crystal oscillator terminal
35	XOUT	O	(4MHz)

Pin No.	Mark	I/O	Function
36~40	SFC1~SFC5	-	Not used
41	TNR_CE	O	Chip enable signal
42	SEL/TNR_DT	O	Serial data signal
43	SEL/TNR_CK	O	Serial clock signal
44	TV/VCR2	-	Not used
45	ADAPTOR	-	Not used
46	HOLD	I	Hold signal input terminal
47	REMOTE	I	Remote control terminal
48	GND	-	GND terminal
49	SEL_ST	O	Level shift control terminal
50	HELP_LED	-	Not used
51	STANDBY_LED	-	Not used
52	VDD	I	Power supply terminal
53	REC_MUTE	-	Not used
54	S/C_SP	-	Not used
55	SP_B	-	Not used
56	SP_A	O	Speaker select control terminal
57	POWER_RLY	O	Relay control terminal
58	AF_MUTE	O	Muting control terminal
59	LIMITTER	-	Not used
60	INIT_IN	-	Not used, connect to resistor
61~70	S16~S7	O	Segment signal of FL display
71	VLOAD	I	Power supply terminal
72~77	S6~S1	O	Segment signal of FL display
78~80	D1~D3	O	Digit signal of FL display

## Terminal Guide of ICs, Transistors and Diodes

<p>LA1832A LC7218</p>	<p>AN6558-F M5218AP UPC4570C</p>	<p>TC9163N</p>	<p>RSN3305-P</p>	<p>BA6218</p>	<p>UPD78043A041 (80P)</p>
<p>2SC3311ARTA</p>	<p>2SK544F-AC</p>	<p>2SA1534AQRTA 2SC3940AQSTA 2SB621ARTA</p>	<p>RVTDTTC144YST 2SA933SSTA</p>	<p>2SB1548PQAU 2SD2374PQAU</p>	<p>1N5402BM21 SB360L6508</p>
<p>2SC2785FETA 2SC2786MTA</p>	<p>2SC2787FL1TA 2SC2787LTA 2SA1309ARTA 2SD1915FTA UN411FTA UN421FTA</p>	<p>SVC211SPA-AL</p>	<p>RVD1SS133TA MTZJ5R1BTA 1SR35200TB MA700ATA 1SS291TA</p>	<p>MTZJ16CTA MTZJ3R9ATA</p>	<p>MTZJ4R7BTA MTZJ6R2BTA MTZJ6R8BTA MTZJ7R5CTA MTZJ27DTA</p>

Printed Circuit Board

POWER SUPPLY P.C.B. (REP2253F-P)

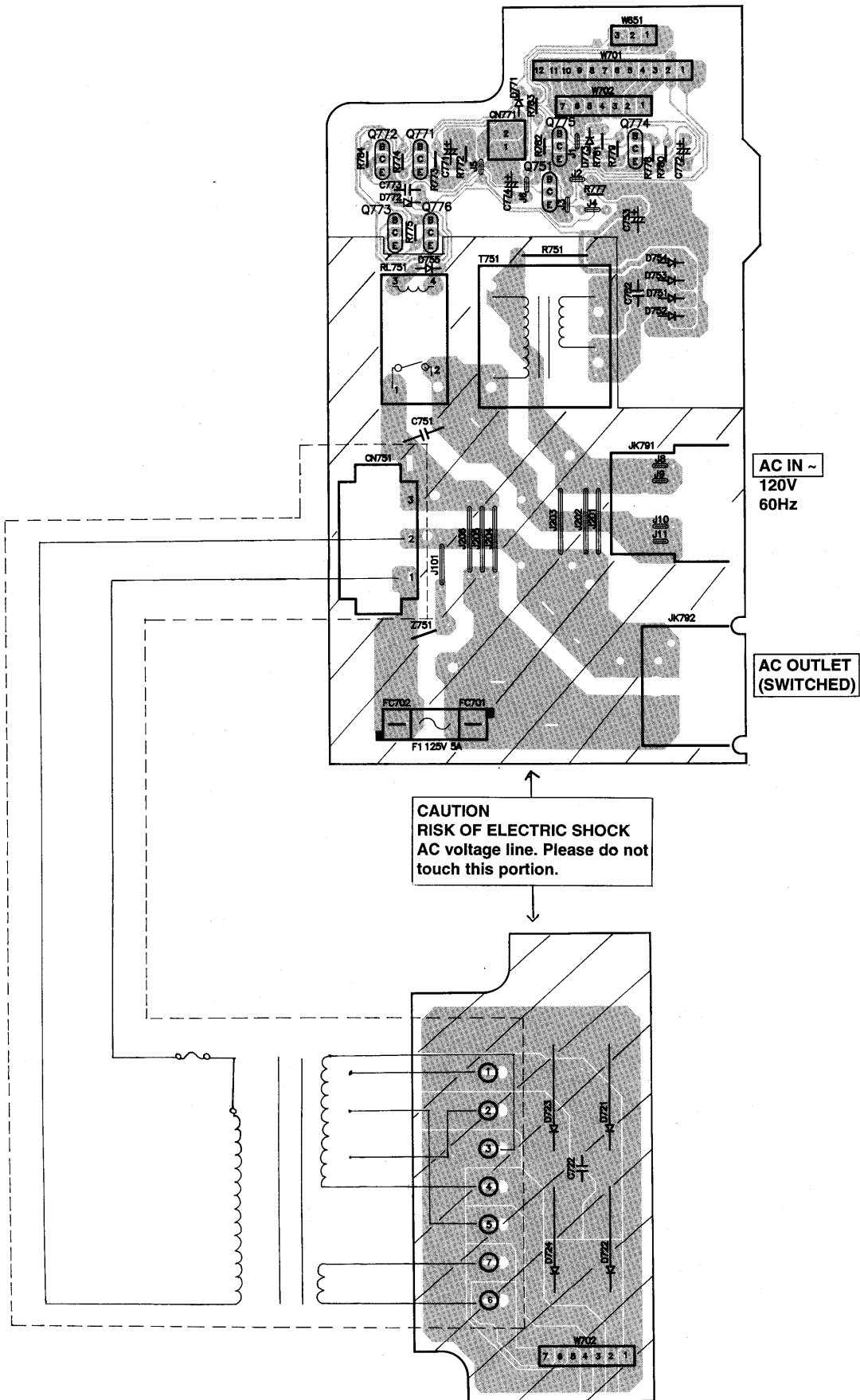

**E** MAIN P.C.B. (REP2251D-M)

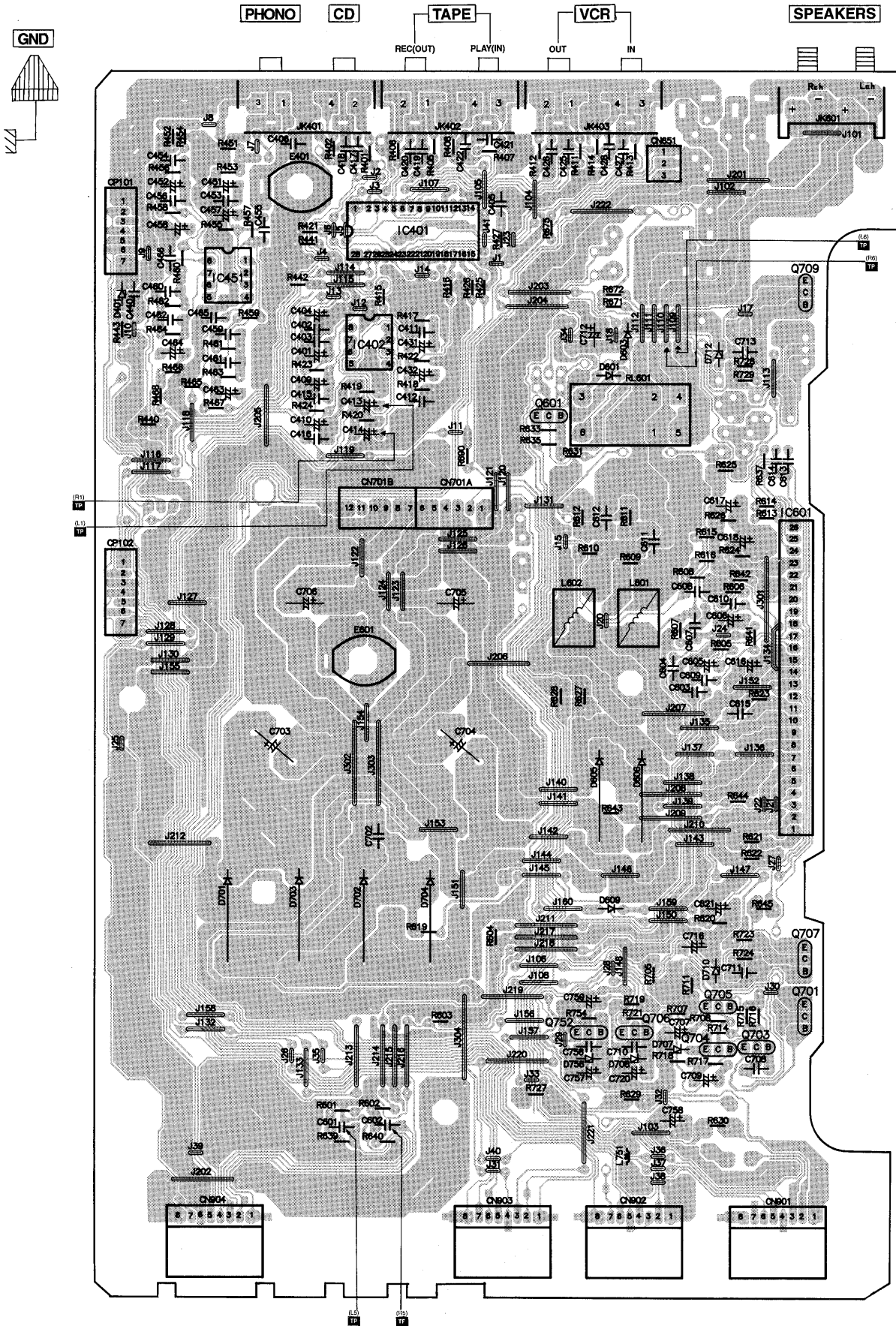

# Schematic Diagram

## E MAIN CIRCUIT

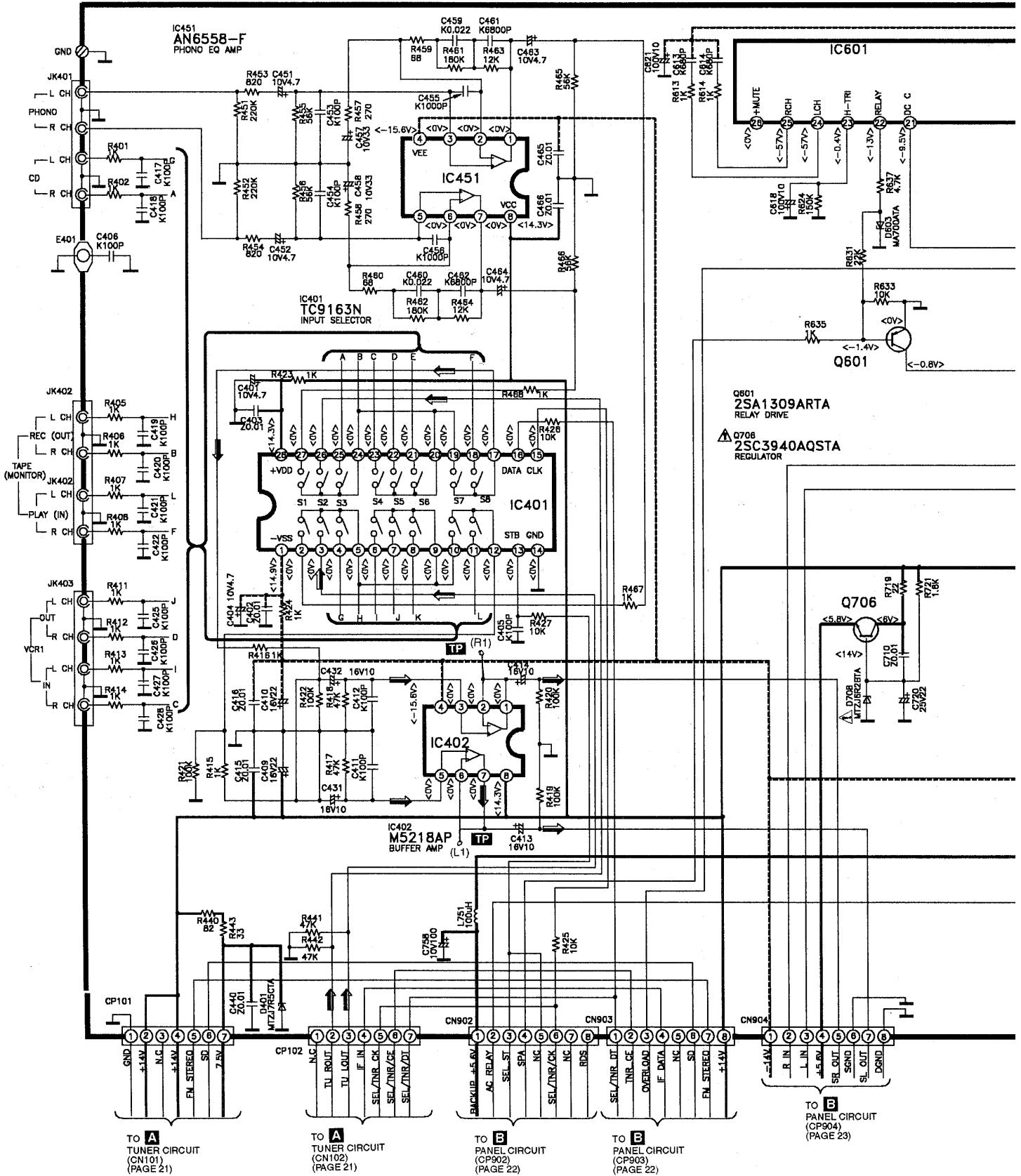

TO A  
TUNER CIRCUIT  
(CN101)  
(PAGE 21)

TO A  
TUNER CIRCUIT  
(CN102)  
(PAGE 21)

TO E  
PANEL CIRCUIT  
(CP902)  
(PAGE 22)

TO B  
PANEL CIRCUIT  
(CP903)  
(PAGE 22)

TO B  
PANEL CIRCUIT  
(CP904)  
(PAGE 23)

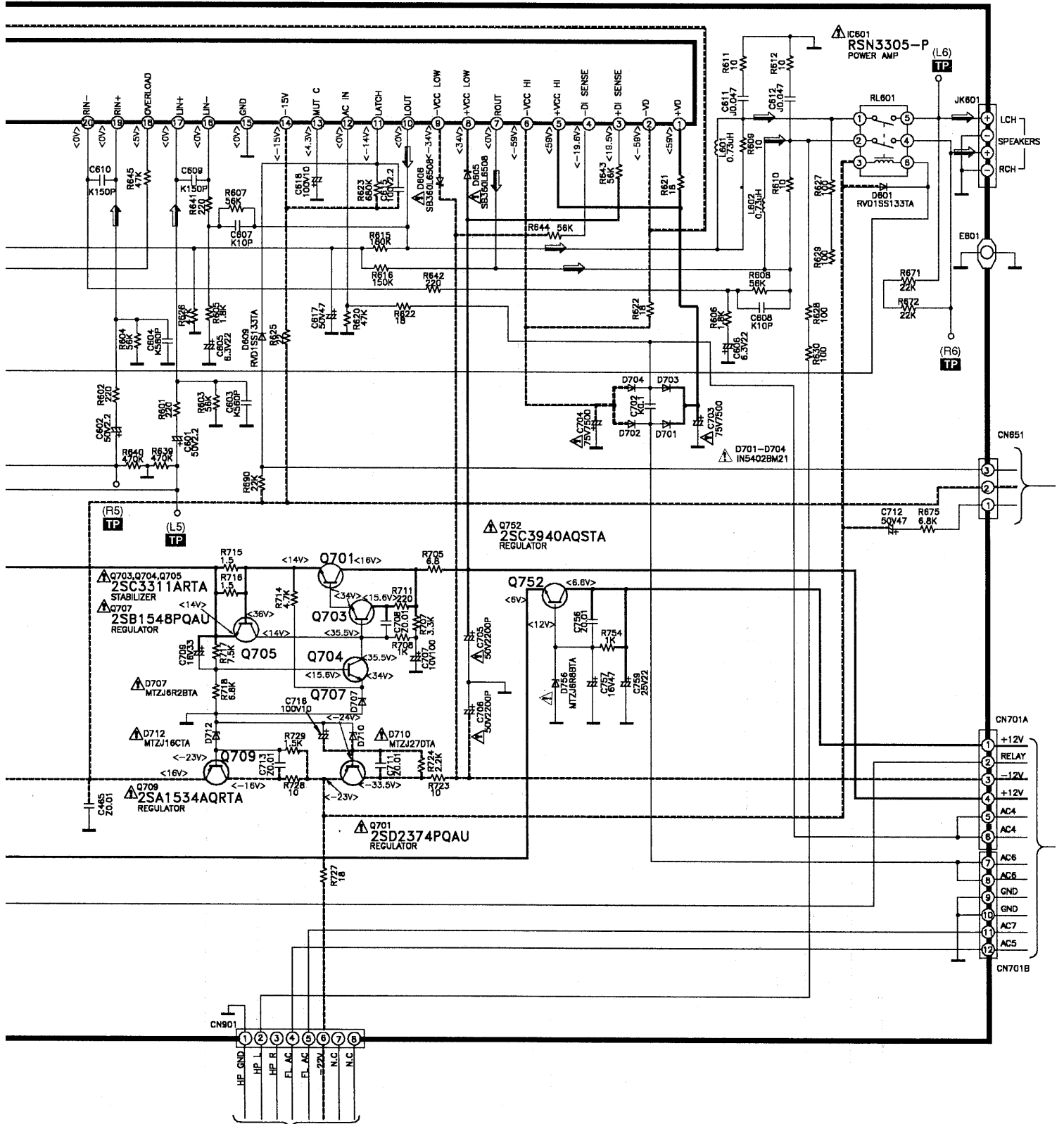

TO **B**  
PANEL CIRCUIT  
(CP901)  
(PAGE 22)



**F** POWER CIRCUIT

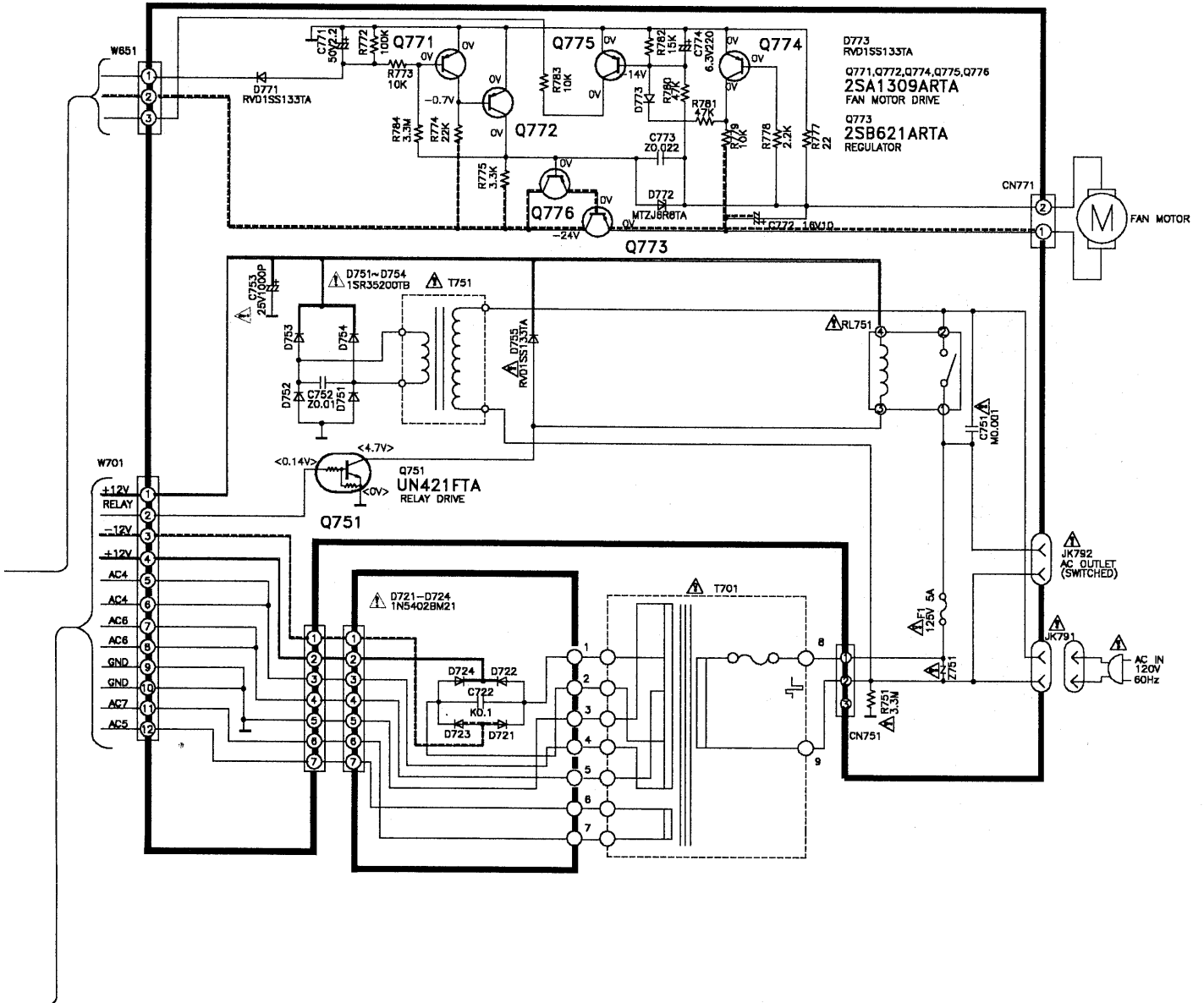

# ■ Cabinet Parts Location

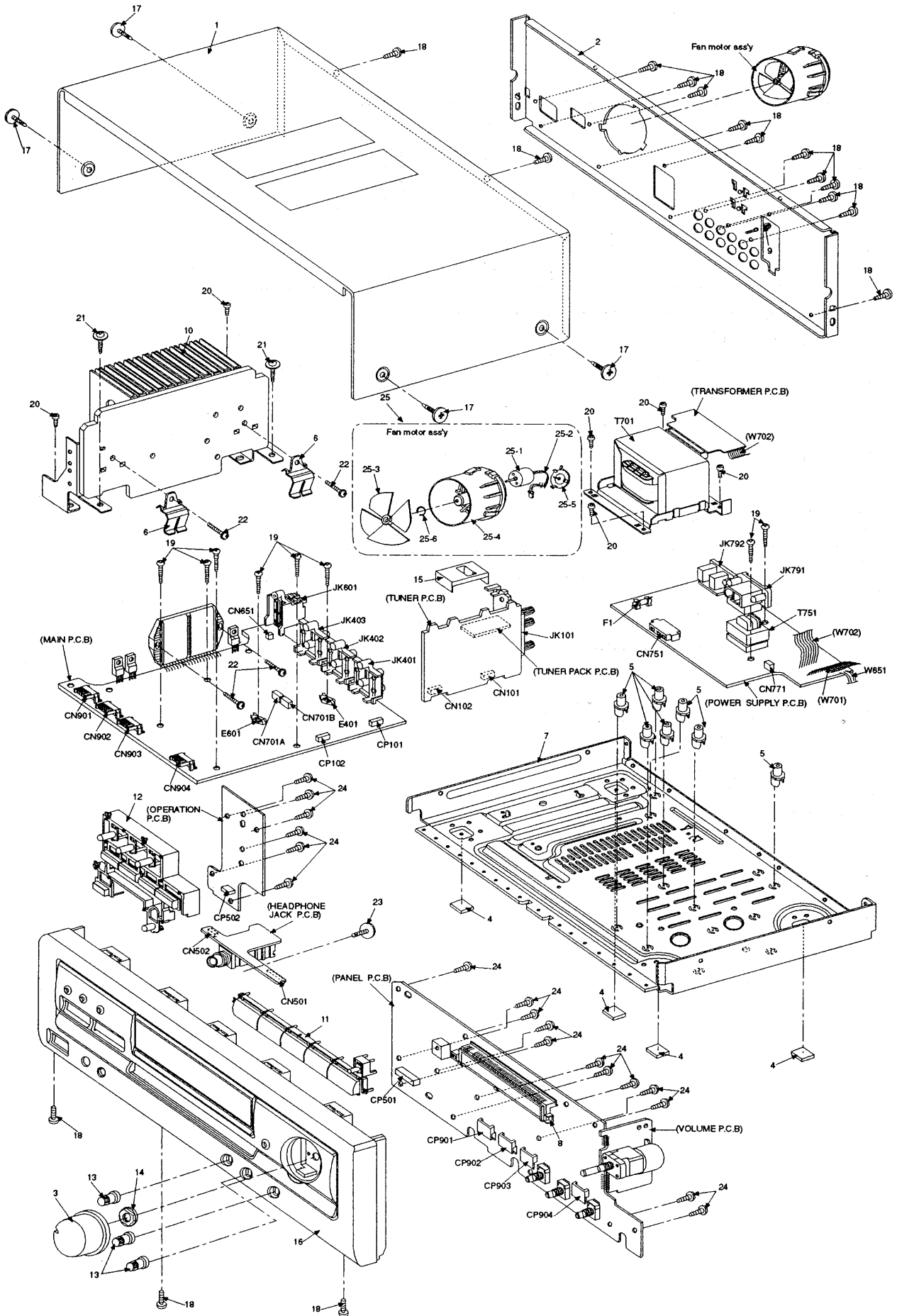

## ■ Replacement Parts List

**Notes:** \* Important safety notice :

 Components identified by  mark have special characteristics important for safety.

Furthermore, special parts which have purposes of fire-retardant (resistors), high-quality sound (capacitors), low-noise (resistors), etc. are used. When replacing any of components, be sure to use only manufacturer's specified parts shown in the parts list.























\* The parenthesized in the Remarks columns specify the areas. (Refer to the cover page for area.)

Parts without these indication can be used for all areas.

\* [M] in Remarks column indicates parts that are supplied by MESA.

\* [MAV] in Remarks column indicates parts that are supplied by MAV.

\* The "(SF)" mark denotes the standard part.

Ref No.	Part No.	Part Name & Description	Remarks	Ref No.	Part No.	Part Name & Description	Remarks	Ref No.	Part No.	Part Name & Description	Remarks
		<b>CABINET AND CHASSIS</b>		IC402	M5218AP	BUFFER AMP		Q901	RVTDT114YST	TRANSISTOR	
				IC451	AN6558-F	OP AMP IC	[M]	Q902	2SA933SSTA	TRANSISTOR	
1	RKM0260B-KJ	TOP CABINET	[M]	IC501	BA6218	MOTOR DRIVER IC					
2	RGR0178H-A	REAR PANEL	[MAV]	IC511	UPC4570C	TONE CONTROL IC				<b>DIODES</b>	
3	RGW0243A-K	VOLUME KNOB	[MAV]	IC601	RSN3305-P	HIC	[MAV] 				
4	SKL293	LEG CUSHION		IC901	UPD78043A041	MICRO COMPUTER	[MAV]	D1	SVC211SPA-AL	DIODE	
5	RKQ0089	PCB SUPPORT						D2	SVC211SPA-AL	DIODE	
6	RMC0158-S	TR FIXTURE	[M]			<b>TRANSISTORS</b>		D3	SVC211SPA-AL	DIODE	
7	RMK0276	BOTTOM CHASSIS	[M]					D101	MTZJ5R1BTA	DIODE	
8	RMN0372	FL HOLDER	[MAV]	Q1	2SK544F-AC	TRANSISTOR		D102	RVD1SS133TA	DIODE	
9	SNE2123	EARTH TERMINAL		Q2	2SC2786MTA	TRANSISTOR		D401	MTZJ7R5CTA	DIODE	
10	RXX0169	HEAT SINK UNIT	[MAV]	Q3	2SC2787FL1TA	TRANSISTOR		D601	RVD1SS133TA	DIODE	
11	RGU1349-K	SELECTOR BUTTON	[MAV]	Q4	2SC2787FL1TA	TRANSISTOR		D603	MA700ATA	DIODE	
12	RGU1350-K	MODE BUTTON	[MAV]	Q101	2SC2787LTA	TRANSISTOR		D605	SB360L6508	DIODE	
13	RGW0244-K	BASS TREBLE KNOB	[MAV]	Q103	2SC2785FETA	TRANSISTOR		D606	SB360L6508	DIODE	
14	RHN90001	M9 NUT		Q104	2SC2785FETA	TRANSISTOR		D609	RVD1SS133TA	DIODE	
15	RSC0027	TUNER PACK		Q106	UN411FTA	TRANSISTOR		D701	1N5402BM21	DIODE	
16	RFKGSAG56PPK	FRONT PANEL ASS'Y	[MAV]	Q107	2SC3311ARTA	TRANSISTOR		D702	1N5402BM21	DIODE	
17	SNE2129-1	SCREW (CABINET)		Q108	2SC3311ARTA	TRANSISTOR		D703	1N5402BM21	DIODE	
18	XTBS3+8JFZ1	SCREW		Q505	2SD1915FTA	TRANSISTOR		D704	1N5402BM21	DIODE	
19	XTB3+20JFZ	SCREW		Q506	2SD1915FTA	TRANSISTOR		D707	MTZJ6R2BTA	DIODE	
20	XTB3+8FFZ	SCREW		Q601	2SA1309ARTA	TRANSISTOR		D708	MTZJ6R2BTA	DIODE	
21	XTWS3+8T	SCREW		Q681	2SD1915FTA	TRANSISTOR		D710	MTZJ27DTA	DIODE	
22	XTW3+15T	SCREW		Q682	2SD1915FTA	TRANSISTOR		D712	MTZJ16CTA	DIODE	
23	RHD26016	SCREW		Q701	2SD2374PQAU	TRANSISTOR		D721	1N5402BM21	DIODE	
24	XTBS26+10J	SCREW		Q703	2SC3311ARTA	TRANSISTOR		D722	1N5402BM21	DIODE	
25	RYQ0173-K	FAN UNIT	[MAV]	Q704	2SC3311ARTA	TRANSISTOR		D723	1N5402BM21	DIODE	
25-1	MDN-4RB4MRC	MOTOR		Q705	2SC3311ARTA	TRANSISTOR		D724	1N5402BM21	DIODE	
25-2	REX0811	CONNECTOR UNIT	[MAV]	Q706	2SC3940AQSTA	TRANSISTOR		D751	1SR35200TB	DIODE	
25-3	SHE232	64MM FAN		Q707	2SB1548PQAU	TRANSISTOR		D752	1SR35200TB	DIODE	
25-4	SHE233-1	FAN CASE		Q709	2SA1534AQRTA	TRANSISTOR	[M] 	D753	1SR35200TB	DIODE	
25-5	SHE234	FAN CASE COVER		Q751	UN421FTA	TRANSISTOR		D754	1SR35200TB	DIODE	
25-6	SUS271	MOTOR SPRING		Q752	2SC3940AQSTA	TRANSISTOR		D755	RVD1SS133TA	DIODE	
		<b>INTEGRATED CIRCUITS</b>		Q771	2SA1309ARTA	TRANSISTOR		D756	MTZJ6R8BTA	DIODE	
				Q772	2SA1309ARTA	TRANSISTOR		D771	RVD1SS133TA	DIODE	
				Q773	2SB621ARTA	TRANSISTOR		D772	MTZJ6R8BTA	DIODE	
IC101	LA1832A	IF/MPX IC		Q774	2SA1309ARTA	TRANSISTOR		D773	RVD1SS133TA	DIODE	
IC102	LC7218	PLL IC		Q775	2SA1309ARTA	TRANSISTOR		D901	1SS291TA	DIODE	
IC401	TC9163N	SELECTOR IC		Q776	2SA1309ARTA	TRANSISTOR		D903	MTZJ4R7BTA	DIODE	

Ref No.	Part No.	Part Name & Description	Remarks	Ref No.	Part No.	Part Name & Description	Remarks	Ref No.	Part No.	Part Name & Description	Remarks
D921	RVD1SS133TA	DIODE		CP901	RJT003K008M1	8P CONNECTOR				<b>FUSE CLIPS</b>	
D923	RVD1SS133TA	DIODE		CP902	RJT003K008M1	8P CONNECTOR					
D924	MTZJ3R9ATA	DIODE		CP903	RJT003K008M1	8P CONNECTOR		FC701	EYF52BC	FUSE HOLDER	
				CP904	RJT003K008M1	8P CONNECTOR		FC702	EYF52BC	FUSE HOLDER	
		<b>VARIABLE RESISTORS</b>								<b>JACKS</b>	
VR501	EUWMGB026B15	MOTOR VOLUME	[MAV]								
VR502	EVJ02QF01G15	VARIABLE RESISTOR		L1	RLQZP1R2KT-Y	NIL		JK101	RJH4405	ANT TERMINAL	
VR511	EVJYA1F01C15	VARIABLE RESISTOR		L2	RLQZPR47KT-Y	NIL		JK401	SJF3069N	LINE IN JACK	
VR512	EVJYA1F01C15	VARIABLE RESISTOR		L101	ELESN1R5MA	CHOKO COIL		JK402	SJF3069N	LINE IN JACK	
				L103	ELETR47MA9	CHOKO COIL		JK403	SJF3069N	LINE IN JACK	
		<b>SWITCHES</b>		L501	RLQZP1R0KT-Y	AXIAL COIL		JK601	RJR0054	SP TERMINAL	
				L502	RLQZP1R0KT-Y	AXIAL COIL		JK791	SJSD16-1	AC INLET	⚠
S946	EVQ21405R	TACT SWITCH		L601	RLQYR73M	CHOKO COIL		JK792	RJS1A1602-2S	AC OUTLET	⚠
S947	EVQ21405R	TACT SWITCH		L602	RLQYR73M	CHOKO COIL					
S948	EVQ21405R	TACT SWITCH		L751	ELESN101KA	CHOKO COIL				<b>RELAYS</b>	
S950	EVQ21405R	TACT SWITCH		L901	RLQB101KTA-Y	CHOKO COIL					
S951	EVQ21405R	TACT SWITCH		T701	RTP1N5C012-V	POWER TRANSFORMER	[MAV] ⚠	RL601	RSY0013M-0	24V RELAY	
S952	EVQ21405R	TACT SWITCH		T751	RTP1H5C001-V	POWER TRANSFORMER	⚠	RL751	RSY0019M-0	12V TV-5 RELAY	⚠
S953	EVQ21405R	TACT SWITCH									
S954	EVQ21405R	TACT SWITCH				<b>COMPONENT COMBINATION</b>				<b>HEADPHONE</b>	
S956	EVQ21405R	TACT SWITCH									
S957	EVQ21405R	TACT SWITCH		Z101	RLA2Z002M-T	AM ANT. COIL		HP601	RJJ63TS01	HEADPHONES JACK	
S960	EVQ21405R	TACT SWITCH		Z102	RLI2Z006M-T	AM IFT					
S961	EVQ21405R	TACT SWITCH		Z751	ERZV10V511CS	ZNR	⚠			<b>EARTH TERMINAL</b>	
S962	EVQ21405R	TACT SWITCH		Z891	RCDSPS4242N	REMOTE SENSOR					
S964	EVQ21405R	TACT SWITCH						E401	SNE1004-2	EARTH TERMINAL	
S980	EVQ21405R	TACT SWITCH				<b>CERAMIC FILTERS</b>		E601	SNE1004-2	EARTH TERMINAL	
		<b>CONNECTORS</b>								<b>PACKING MATERIALS</b>	
CN101	RJU057W007	CONNECTOR (7P)		CF201	RLFFETMGD01L	CERAMIC FILTER					
CN102	RJU057W007	CONNECTOR (7P)		CF202	RLFFETMGD01L	CERAMIC FILTER					
CN501	RJU100W07	7P CONNECTOR	[MAV]	CF901	RVCBST4R00MT	CERAMIC OSCILLATOR		P2	RPG2996	PACKING CASE	[MAV]
CN502	RJU100W04	4P CONNECTOR	[MAV]					P3	RPN0865	POLYFOAM	[M]
CN651	RJS1A6603	NIL				<b>OSCILLATORS</b>		P4	RPFX0005	MIRAMAT BAG	[M]
CN701A	RJS1A6606	TAPING CONNECTOR		X101	RSXZ456KM07M	CERAMIC OSCILLATOR					
CN701B	RJS1A6606	TAPING CONNECTOR		X102	RLFDGTD01I	FM RESONATOR					
CN751	SJS305-1	CONNECTOR (3P)		X103	SVQ49U722T-S	CRYSTAL OSCILLATOR					
CN771	SJT3213	CONNECTOR (FAN)									
CN901	RJU003K008M1	BOARD IN CONNECTOR				<b>DISPLAY TUBE</b>					
CN902	RJU003K008M1	BOARD IN CONNECTOR		FL901	RSL0213-F	FL DISPLAY	[MAV]				
CN903	RJU003K008M1	BOARD IN CONNECTOR									
CN904	RJU003K008M1	BOARD IN CONNECTOR				<b>FUSES</b>					
CP101	RJT057W007-1	7P CONNECTOR									
CP102	RJT057W007-1	7P CONNECTOR		F1	XBA1C50NBAL	FUSE	[M] ⚠				
CP501	RJT100W07	7P CONNECTOR	[MAV]								
CP502	RJT100W04	CONNECTOR (4P)	[MAV]								

## Resistors & Capacitors

Notes : \* Important safety notice:  
 Components identified by  $\Delta$  mark have special characteristics important for safety.  
 Furthermore, special parts which have purposes of fire-retardant (resistors), high-quality sound (capacitors), low-noise (resistors), etc. are used.  
 When replacing any of components, be sure to use only manufacturer's specified parts shown in the parts list.  
 \* Capacitor values are in microfarad ( $\mu$ F) unless specified otherwise, P=Pico-farads (pF) F=Farads (F)  
 \* Resistors values are in ohms, unless specified otherwise, 1k=1,000(OHM), 1M=1,000k(OHM)

Ref No.	Part No.	Values & Remarks	Ref No.	Part No.	Values & Remarks	Ref No.	Part No.	Values & Remarks	Ref No.	Part No.	Values & Remarks
		<b>RESISTORS</b>	R136	ERDS2TJ102T	1K 1/4W	R441	ERDS2TJ473T	47K 1/4W	R527	ERDS2TJ122T	1.2K 1/4W
			R137	ERDS2TJ102T	1K 1/4W	R442	ERDS2TJ473T	47K 1/4W	R528	ERDS2TJ122T	1.2K 1/4W
R1	ERDS2TJ104T	100K 1/4W	R139	ERDS2TJ272T	2.7K 1/4W	R443	ERDS2TJ330T	33 1/4W	R529	ERDS2TJ273T	27K 1/4W
R2	ERDS2TJ104T	100K 1/4W	R140	ERDS2TJ272T	2.7K 1/4W	R451	ERDS2TJ224T	220K 1/4W	R530	ERDS2TJ273T	27K 1/4W
R3	ERDS2TJ221T	220 1/4W	R141	ERDS2TJ103T	10K 1/4W	R452	ERDS2TJ224T	220K 1/4W	R531	ERDS2TJ332T	3.3K 1/4W
R4	ERDS2TJ104T	100K 1/4W	R142	ERDS2TJ103T	10K 1/4W	R453	ERDS2TJ821T	820 1/4W	R532	ERDS2TJ332T	3.3K 1/4W
R5	ERDS2TJ564T	560K 1/4W	R143	ERDS2TJ222T	2.2K 1/4W	R454	ERDS2TJ821T	820 1/4W	R533	ERDS2TJ332T	3.3K 1/4W
R6	ERDS2TJ391T	390 1/4W	R144	ERDS2TJ222T	2.2K 1/4W	R455	ERDS2TJ563T	56K 1/4W	R534	ERDS2TJ332T	3.3K 1/4W
R7	ERDS2TJ272T	2.7K 1/4W	R145	ERDS2TJ102T	1K 1/4W	R456	ERDS2TJ563T	56K 1/4W	R543	ERDS2TJ102T	1K 1/4W
R8	ERDS2TJ684T	680K 1/4W	R146	ERDS2TJ102T	1K 1/4W	R457	ERDS2TJ271T	270 1/4W	R544	ERDS2TJ102T	1K 1/4W
R9	ERDS2TJ391T	390 1/4W	R147	ERDS2TJ474T	470K 1/4W	R458	ERDS2TJ271T	270 1/4W	R545	ERDS2TJ824T	820K 1/4W
R10	ERDS2TJ391T	390 1/4W	R148	ERDS2TJ474T	470K 1/4W	R459	ERDS2TJ680T	68 1/4W	R546	ERDS2TJ332T	3.3K 1/4W
R11	ERDS2TJ684T	680K 1/4W	R149	ERDS2TJ680T	68 1/4W	R460	ERDS2TJ680T	68 1/4W	R601	ERDS2TJ221T	220 1/4W
R103	ERDS2TJ151T	150 1/4W	R171	ERDS2TJ102T	1K 1/4W	R461	ERDS2TJ184T	180K 1/4W	R602	ERDS2TJ221T	220 1/4W
R104	ERDS2TJ102T	1K 1/4W	R172	ERDS2TJ102T	1K 1/4W	R462	ERDS2TJ184T	180K 1/4W	R603	ERDS2TJ563T	56K 1/4W
R105	ERDS2TJ471T	470 1/4W	R173	ERDS2TJ471T	470 1/4W	R463	ERDS2TJ123T	12K 1/4W	R604	ERDS2TJ563T	56K 1/4W
R106	ERDS2TJ224T	220K 1/4W	R175	ERDS2TJ102T	1K 1/4W	R464	ERDS2TJ123T	12K 1/4W	R605	ERDS2TJ182T	1.8K 1/4W
R107	ERDS2TJ471T	470 1/4W	R176	ERDS2TJ391T	390 1/4W	R465	ERDS2TJ563T	56K 1/4W	R606	ERDS2TJ182T	1.8K 1/4W
R110	ERDS2TJ102T	1K 1/4W	R401	ERDS2TJ102T	1K 1/4W	R466	ERDS2TJ563T	56K 1/4W	R607	ERDS2TJ563T	56K 1/4W
R112	ERDS2TJ104T	100K 1/4W	R402	ERDS2TJ102T	1K 1/4W	R467	ERDS2TJ102T	1K 1/4W	R608	ERDS2TJ563T	56K 1/4W
R113	ERDS2TJ103T	10K 1/4W	R405	ERDS2TJ102T	1K 1/4W	R468	ERDS2TJ102T	1K 1/4W	R609	ERDS2TJ100T	10 1/4W
R114	ERDS2TJ562T	5.6K 1/4W	R406	ERDS2TJ102T	1K 1/4W	R501	ERDS2TJ222T	2.2K 1/4W	R610	ERDS2TJ100T	10 1/4W
R115	ERDS2TJ561T	560 1/4W	R407	ERDS2TJ102T	1K 1/4W	R502	ERDS2TJ222T	2.2K 1/4W	R611	ERDS1FVJ100T	10 1/2W
R116	ERDS2TJ102T	1K 1/4W	R408	ERDS2TJ102T	1K 1/4W	R503	ERDS2TJ103T	10K 1/4W	R612	ERDS1FVJ100T	10 1/2W
R117	ERDS2TJ104T	100K 1/4W	R411	ERDS2TJ102T	1K 1/4W	R504	ERDS2TJ103T	10K 1/4W	R613	ERDS2TJ102T	1K 1/4W
R118	ERDS2TJ562T	5.6K 1/4W	R412	ERDS2TJ102T	1K 1/4W	R508	ERDS1FVJ2R2T	2.2 1/2W	R614	ERDS2TJ102T	1K 1/4W
R119	ERDS2TJ822T	8.2K 1/4W	R413	ERDS2TJ102T	1K 1/4W	R511	ERDS2TJ471T	470 1/4W	R615	ERDS2TJ184T	180K 1/4W
R120	ERDS2TJ473T	47K 1/4W	R414	ERDS2TJ102T	1K 1/4W	R512	ERDS2TJ471T	470 1/4W	R616	ERDS2TJ154T	150K 1/4W
R121	ERDS2TJ332T	3.3K 1/4W	R415	ERDS2TJ102T	1K 1/4W	R513	ERDS2TJ474T	470K 1/4W	R619	ERDS2TJ684T	680K 1/4W
R122	ERDS2TJ272T	2.7K 1/4W	R416	ERDS2TJ102T	1K 1/4W	R514	ERDS2TJ474T	470K 1/4W	R620	ERDS2TJ473T	47K 1/4W
R124	ERDS2TJ271T	270 1/4W	R417	ERDS2TJ473T	47K 1/4W	R515	ERDS2TJ474T	470K 1/4W	R621	ERD25FVJ180T	18 1/4W
R125	ERDS2TJ472T	4.7K 1/4W	R418	ERDS2TJ473T	47K 1/4W	R516	ERDS2TJ474T	470K 1/4W	R622	ERD25FVJ180T	18 1/4W
R126	ERDS2TJ472T	4.7K 1/4W	R419	ERDS2TJ104T	100K 1/4W	R517	ERDS2TJ272T	2.7K 1/4W	R623	ERDS2TJ684T	680K 1/4W
R127	ERDS2TJ103T	10K 1/4W	R420	ERDS2TJ104T	100K 1/4W	R518	ERDS2TJ272T	2.7K 1/4W	R624	ERDS2TJ154T	150K 1/4W
R128	ERDS2TJ820T	82 1/4W	R421	ERDS2TJ104T	100K 1/4W	R519	ERDS2TJ392T	3.9K 1/4W	R625	ERD25FVJ220T	22 1/4W
R129	ERDS2TJ473T	47K 1/4W	R422	ERDS2TJ104T	100K 1/4W	R520	ERDS2TJ392T	3.9K 1/4W	R626	ERDS2TJ473T	47K 1/4W
R130	ERDS2TJ102T	1K 1/4W	R423	ERDS2TJ102T	1K 1/4W	R521	ERDS2TJ223T	22K 1/4W	R627	ERG1SJ101E	100 1W
R131	ERDS2TJ102T	1K 1/4W	R424	ERDS2TJ102T	1K 1/4W	R522	ERDS2TJ223T	22K 1/4W	R628	ERG1SJ101E	100 1W
R132	ERDS2TJ103T	10K 1/4W	R425	ERDS2TJ103T	10K 1/4W	R523	ERDS2TJ392T	3.9K 1/4W	R629	ERG1SJ101E	100 1W
R133	ERDS2TJ102T	1K 1/4W	R426	ERDS2TJ103T	10K 1/4W	R524	ERDS2TJ392T	3.9K 1/4W	R630	ERG1SJ101E	100 1W
R134	ERDS2TJ102T	1K 1/4W	R427	ERDS2TJ103T	10K 1/4W	R525	ERDS2TJ222T	2.2K 1/4W	R631	ERDS2TJ223T	22K 1/4W
R135	ERDS2TJ102T	1K 1/4W	R440	ERDS1FVJ820T	82 1/2W	R526	ERDS2TJ222T	2.2K 1/4W	R633	ERDS2TJ103T	10K 1/4W

Ref No.	Part No.	Values & Remarks	Ref No.	Part No.	Values & Remarks	Ref No.	Part No.	Values & Remarks	Ref No.	Part No.	Values & Remarks
R635	ERDS2TJ102T	1K 1/4W	R772	ERDS2TJ104T	100K 1/4W	0	CAPACITORS		C138	ECBT1H271KB5	270P 50V
R637	ERDS2TJ472T	4.7K 1/4W	R773	ERDS2TJ103T	10K 1/4W				C141	ECEA1HKA010B	1 50V
R639	ERDS2TJ474T	470K 1/4W	R774	ERDS2TJ223T	22K 1/4W	C1	ECKR1H473ZF5	0.047 50V	C142	ECEA1HKA010B	1 50V
R640	ERDS2TJ474T	470K 1/4W	R775	ERDS2TJ332T	3.3K 1/4W	C1	ECBT1H5R6KC5	5.6P 50V	C143	ECEA1HKA010B	1 50V
R641	ERDS2TJ221T	220 1/4W	R777	ERDS2TJ220T	22 1/4W	C2	RCBS1H102KB5	1000P 50V	C144	ECEA1HKA010B	1 50V
R642	ERDS2TJ221T	220 1/4W	R778	ERDS2TJ222T	2.2K 1/4W	C3	ECBT1H2R2KC5	2.2P 50V	C145	ECBT1H220JC5	22P 50V
R643	ERDS2TJ563T	56K 1/4W	R779	ERDS2TJ103T	10K 1/4W	C4	ECBT1H181KB5	180P 50V	C146	ECBT1H331KB5	330P 50V
R644	ERDS2TJ563T	56K 1/4W	R780	ERDS2TJ473T	47K 1/4W	C5	ECBT1H5R6KC5	5.6P 50V	C147	ECBT1H102KB5	1000P 50V
R645	ERDS2TJ473T	47K 1/4W	R781	ERDS2TJ473T	47K 1/4W	C6	ECBT1H3R3KC5	3.3P 50V	C148	ECBT1C103NS5	0.01 16V
R671	ERDS2TJ223T	22K 1/4W	R782	ERDS2TJ153T	15K 1/4W	C7	ECBT1H4R7KC5	4.7P 50V	C149	ECBT1C103NS5	0.01 16V
R672	ERDS2TJ223T	22K 1/4W	R783	ERDS2TJ103T	10K 1/4W	C8	ECBT1H3R3KC5	3.3P 50V	C150	ECBT1H104ZF5	0.1 50V
R675	ERDS2TJ682T	6.8K 1/4W	R784	ERDS2TJ335T	3.3M 1/4W	C9	ECBT1H2R2KC5	2.2P 50V	C172	ECBT1H331KB5	330P 50V
R681	ERDS2TJ270T	27 1/4W	R901	ERDS2TJ102T	1K 1/4W	C10	ECBT1H180JC5	18P 50V	C173	ECEA1CKA220B	22 16V
R682	ERDS2TJ270T	27 1/4W	R906	ERDS2TJ104T	100K 1/4W	C11	RCBS1H102KB5	1000P 50V	C174	ECEA1CKA100B	10 16V
R683	ERDS2TJ270T	27 1/4W	R907	ERDS2TJ104T	100K 1/4W	C101	ECBT1C103NS5	0.01 16V	C175	ECBT1C103NS5	0.01 16V
R684	ERDS2TJ270T	27 1/4W	R908	ERDS2TJ104T	100K 1/4W	C103	ECBT1C103NS5	0.01 16V	C196	ECBT1H102KB5	1000P 50V
R685	ERDS2TJ270T	27 1/4W	R909	ERDS2TJ104T	100K 1/4W	C104	ECBT1H102KB5	1000P 50V	C401	ECEA1VKA4R7B	4.7 10V
R686	ERDS2TJ270T	27 1/4W	R910	ERDS2TJ102T	1K 1/4W	C105	ECBT1H102KB5	1000P 50V	C402	ECBT1E103ZF5	0.01 25V
R687	ERDS2TJ270T	27 1/4W	R911	ERDS2TJ104T	100K 1/4W	C106	ECBT1C103NS5	0.01 16V	C403	ECBT1E103ZF5	0.01 25V
R688	ERDS2TJ270T	27 1/4W	R912	ERDS2TJ103T	10K 1/4W	C107	ECBT1H473ZF5	0.047 50V	C404	ECEA1VKA4R7B	4.7 10V
R689	ERDS2TJ270T	27 1/4W	R914	ERDS2TJ274T	270K 1/4W	C108	ECBT1H8R2KC5	8.2P 50V	C405	ECBT1H101KB5	100P 50V
R690	ERDS2TJ223T	22K 1/4W	R917	ERDS2TJ103T	10K 1/4W	C109	ECBT1C103NS5	0.01 16V	C406	ECBT1H101KB5	100P 50V
R690	ERDS2TJ270T	27 1/4W	R920	ERDS2TJ271T	270 1/4W	C110	ECBT1C103NS5	0.01 16V	C409	ECEA1CU220B	22 16V
R691	ERDS2TJ270T	27 1/4W	R921	ERDS2TJ121T	120 1/4W	C111	ECEA1EKA4R7B	4.7 25V	C410	ECEA1CU220B	22 16V
R692	ERDS2TJ270T	27 1/4W	R922	ERDS2TJ472T	4.7K 1/4W	C112	ECBT1C103NS5	0.01 16V	C411	ECBT1H101KB5	100P 50V
R693	ERDS2TJ270T	27 1/4W	R929	ERDS2TJ101T	100 1/4W	C113	ECBT1H102KB5	1000P 50V	C412	ECBT1H101KB5	100P 50V
R694	ERDS2TJ270T	27 1/4W	R930	ERDS2TJ101T	100 1/4W	C114	ECEA1HKA3R3B	3.3 50V	C413	ECEA1CU100B	10 16V
R695	ERDS2TJ102T	1K 1/4W	R946	ERDS2TJ103T	10K 1/4W	C115	ECEA1EKA4R7B	4.7 25V	C414	ECEA1CU100B	10 16V
R696	ERDS2TJ102T	1K 1/4W	R947	ERDS2TJ103T	10K 1/4W	C116	ECBT1C822MS5	8200P 16V	C415	ECBT1E103ZF5	0.01 25V
R699	ERDS2TJ332T	3.3K 1/4W	R948	ERDS2TJ103T	10K 1/4W	C117	ECQB1H821JF3	820P 50V	C416	ECBT1E103ZF5	0.01 25V
R705	ERDS1FVJ6R8T	6.8 1/2W	R949	ERDS2TJ103T	10K 1/4W	C118	ECFR1E183KR	0.018 25V	C417	ECBT1H101KB5	100P 50V
R707	ERDS2TJ332T	3.3K 1/4W	R950	ERDS2TJ102T	1K 1/4W	C119	ECFR1E183KR	0.018 25V	C418	ECBT1H101KB5	100P 50V
R708	ERDS2TJ102T	1K 1/4W	R951	ERDS2TJ122T	1.2K 1/4W	C120	ECEA1HKA010B	1 50V	C419	ECBT1H101KB5	100P 50V
R711	ERD25FVJ221T	220 1/4W	R952	ERDS2TJ152T	1.5K 1/4W	C121	ECEA1HKA010B	1 50V	C420	ECBT1H101KB5	100P 50V
R714	ERDS2TJ472T	4.7K 1/4W	R953	ERDS2TJ182T	1.8K 1/4W	C122	ECEA1HKA2R2B	2.2 50V	C421	ECBT1H101KB5	100P 50V
R715	ERDS2TJ1R5T	1.5 1/4W	R954	ERDS2TJ222T	2.2K 1/4W	C123	ECEA1HKA010B	1 50V	C422	ECBT1H101KB5	100P 50V
R716	ERDS2TJ1R5T	1.5 1/4W	R955	ERDS2TJ332T	3.3K 1/4W	C124	ECBT1H102KB5	1000P 50V	C425	ECBT1H101KB5	100P 50V
R717	ERDS2TJ752T	7.5K 1/4W	R956	ERDS2TJ472T	4.7K 1/4W	C125	ECBT1H150JC5	15P 50V	C426	ECBT1H101KB5	100P 50V
R718	ERDS2TJ682T	6.8K 1/4W	R957	ERDS2TJ682T	6.8K 1/4W	C126	ECBT1H104ZF5	0.1 50V	C427	ECBT1H101KB5	100P 50V
R719	ERDS1FVJ220T	22 1/2W	R960	ERDS2TJ102T	1K 1/4W	C127	ECEA1CKA220B	22 16V	C428	ECBT1H101KB5	100P 50V
R721	ERDS2TJ182T	1.8K 1/4W	R961	ERDS2TJ122T	1.2K 1/4W	C128	ECBT1C103NS5	0.01 16V	C431	ECEA1CU100B	10 16V
R723	ERDS1FVJ100T	10 1/2W	R962	ERDS2TJ152T	1.5K 1/4W	C129	ECEA0JKA101B	100 6.3V	C432	ECEA1CU100B	10 16V
R724	ERDS2TJ222T	2.2K 1/4W	R963	ERDS2TJ182T	1.8K 1/4W	C130	ECEA0JKA101B	100 6.3V	C440	ECBT1E103ZF5	0.01 25V
R727	ERD25FVJ180T	18 1/4W	R964	ERDS2TJ222T	2.2K 1/4W	C131	ECBT1C103NS5	0.01 16V	C451	ECEA1VKA4R7B	4.7 10V
R728	ERDS1FVJ100T	10 1/2W	R980	ERDS2TJ102T	1K 1/4W	C132	ECBT1H102KB5	1000P 50V	C452	ECEA1VKA4R7B	4.7 10V
R729	ERDS2TJ152T	1.5K 1/4W				C133	ECBT1H150JC5	15P 50V	C453	ECBT1H101KB5	100P 50V
R751	ERC12ZGK335D	3.3M 1/2W				C134	ECBT1H180JC5	18P 50V	C454	ECBT1H101KB5	100P 50V
R754	ERDS2TJ102T	1K 1/4W				C137	ECBT1H271KB5	270P 50V	C455	ECBT1H102KB5	1000P 50V

Ref No	Part No.	Values & Remarks	Ref No.	Part No.	Values & Remarks	Ref No.	Part No.	Values & Remarks	Ref No.	Part No.	Values & Remarks
C456	ECBT1H102KB5	1000P 50V	C525	ECQV1H683JZ3	0.068 50V	C621	ECEA2AU100B	10 100V	C902	ECBT1E223ZF5	0.022 25V
C457	ECEA1AU330B	33 10V	C526	ECQV1H683JZ3	0.068 50V	C685	ECBT1E103ZF5	0.01 25V	C903	ECBT1E103ZF5	0.01 25V
C458	ECEA1AU330B	33 10V	C527	ECBT1C562KR5	5600P 16V	C702	ECQE2104KF3	0.1 250V	C904	ECEA0JU102B	1000 6.3V
C459	ECFR1E223KR	0.022 25V	C528	ECBT1C562KR5	5600P 16V	C703	ECES75V752UX	7500 75V ⚠	C906	ECEA0JKA101B	100 6.3V
C460	ECFR1E223KR	0.022 25V	C529	ECQB1H273JF3	0.027 50V	C704	ECES75V752UX	7500 75V ⚠	C908	ECBT1E103ZF5	0.01 25V
C461	ECFR1E682KR	6800P 25V	C530	ECQB1H273JF3	0.027 50V	C705	ECA1HM222B	2200P 50V ⚠	C909	ECEA1HKA220B	22 50V
C462	ECFR1E682KR	6800P 25V	C531	ECBT1E103ZF5	0.01 25V	C706	ECA1HM222B	2200P 50V ⚠	C910	ECEA1HKA220B	22 50V
C463	ECEA1VKA4R7B	4.7 10V	C532	ECBT1E103ZF5	0.01 25V	C707	ECEA1VU101B	100 10V	C911	ECEA1HKA220B	22 50V
C464	ECEA1VKA4R7B	4.7 10V	C533	ECEA1CKA100B	10 16V	C708	ECKR1H103ZF5	0.01 50V	C912	ECEA1HKA220B	22 50V
C465	ECBT1E103ZF5	0.01 25V	C534	ECEA1CKA100B	10 16V	C709	ECEA1CU330B	33 16V	C913	ECEA1VKA100B	10 10V
C466	ECBT1E103ZF5	0.01 25V	C536	ECBT1E103ZF5	0.01 25V	C710	ECBT1E103ZF5	0.01 25V	C914	ECEA1VKA100B	10 10V
C503	ECEA0JKA101B	100 6.3V	C601	ECEA1HN2R2SB	2.2 50V	C711	ECKR1H103ZF5	0.01 50V	C916	ECEA1HKA010B	1 50V
C504	ECEA0JKA101B	100 6.3V	C602	ECEA1HN2R2SB	2.2 50V	C712	ECEA1HU470B	47 50V	C919	ECBT1H101KB5	100P 50V
C505	ECFR1C104MR	0.1 16V	C603	ECBT1H561KB5	560P 50V	C713	ECKR1H103ZF5	0.01 50V	C920	ECEA1HKA010B	1 50V
C506	ECFR1C104MR	0.1 16V	C604	ECBT1H561KB5	560P 50V	C716	ECEA2AU100B	10 100V	C921	ECBT1H331KB5	330P 50V
C511	ECEA1HKA3R3B	3.3 50V	C605	ECA1JM330B	33 6.3V	C720	ECEA1EU220B	22 25V	C922	ECBT1H331KB5	330P 50V
C512	ECEA1HKA3R3B	3.3 50V	C606	ECA1JM330B	33 6.3V	C722	ECQE2104KF3	0.1 250V	C923	ECBT1H331KB5	330P 50V
C513	ECBT1H150J5	15P 50V	C607	ECCR1H100K5	10P 50V	C751	ECKWNS102MBM	0.001 400V ⚠	C924	ECBT1H331KB5	330P 50V
C514	ECBT1H150J5	15P 50V	C608	ECCR1H100K5	10P 50V	C752	ECKR1H103ZF5	0.01 50V	C925	ECBT1H331KB5	330P 50V
C515	ECBT1H221KB5	220P 50V	C609	ECBT1H151KB5	150P 50V	C753	ECA1EM102B	1000P 25V ⚠	C926	ECBT1H331KB5	330P 50V
C516	ECBT1H221KB5	220P 50V	C610	ECBT1H151KB5	150P 50V	C756	ECBT1E103ZF5	0.01 25V	C927	ECBT1H331KB5	330P 50V
C517	ECBT1H330J5	33P 50V	C611	ECQV1H473JZ3	0.047 50V	C757	ECEA1CU470B	47 16V	C928	ECBT1H331KB5	330P 50V
C518	ECBT1H330J5	33P 50V	C612	ECQV1H473JZ3	0.047 50V	C758	ECEA1AU101B	100 10V	C929	ECBT1H331KB5	330P 50V
C519	ECEA1VKA4R7B	4.7 10V	C613	ECBT1H681KB5	680P 50V	C759	ECEA1EU220B	22 25V	C930	ECBT1H331KB5	330P 50V
C520	ECEA1VKA4R7B	4.7 10V	C614	ECBT1H681KB5	680P 50V	C771	ECEA1HU2R2B	2.2 50V	C934	ECBT1H101KB5	100P 50V
C521	ECEA1VKA4R7B	4.7 10V	C615	ECEA2AN2R2SB	2.2 100V	C772	ECEA1CU100B	10 16V	C938	ECBT1H101KB5	100P 50V
C522	ECEA1VKA4R7B	4.7 10V	C616	ECEA2AU100B	10 100V	C773	ECBT1E223ZF5	0.022 25V	C944	ECBT1H101KB5	100P 50V
C523	ECFR1E123KR	0.012 25V	C617	ECEA1HU470B	47 50V	C774	ECEA0JU221B	220 6.3V			
C524	ECFR1E123KR	0.012 25V	C618	ECEA2AU100B	10 100V	C901	ECEA0JU102B	1000 6.3V			

■ Packaging

