

# Service Manual

**QUARTZ** Synthesizer  
AM/FM Stereo Receiver

Receiver  
**SA-GX200**

Color

(K)... Black Type

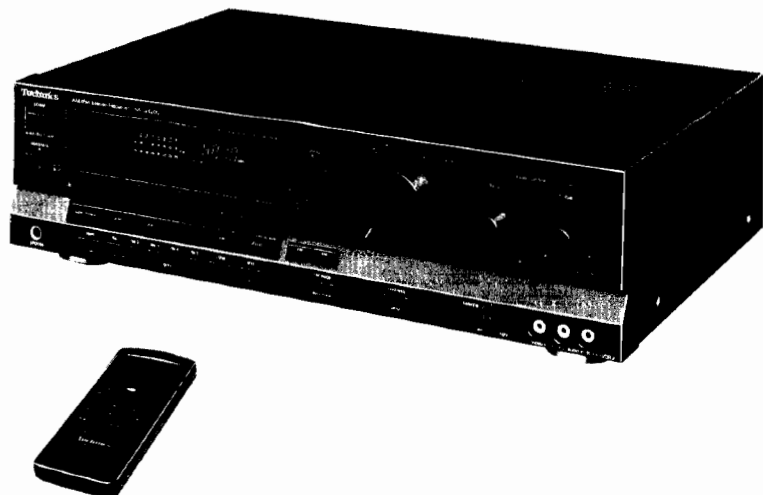

Area

Country Code	Area	Color
(EG)	F.R. Germany & Italy.	(K)

## SPECIFICATIONS (DIN 45 500)

### ■ AMPLIFIER SECTION

<b>Power output</b>	
DIN 1 kHz	2 × 60 W (4 Ω)
40 Hz~20 kHz continuous power output both channels driven	2 × 40 W (8 Ω)
<b>Total harmonic distortion</b>	
rated power at 40 Hz~20 kHz	0.05 % (8 Ω)
half power at 1 kHz	0.03 % (8 Ω)
<b>Intermodulation distortion</b>	
rated power at 60 Hz: 7 kHz=4:1, SMPTE, 8 Ω	0.5 %
<b>Power bandwidth</b>	
both channels driven, -3 dB	10 Hz~40 kHz (8 Ω)
<b>Damping factor</b>	40 (8 Ω)
<b>Input sensitivity and impedance</b>	
PHONO	3 mV/47 kΩ
CD, VCR 1, VCR 2, TAPE	200 mV/22 kΩ
PHONO maximum input voltage (1 kHz, RMS)	150 mV
<b>S/N</b>	
rated power (8 Ω)	
PHONO	70 dB (IHF, A: 80 dB)
CD, VCR 1, VCR 2, TAPE	80 dB (IHF, A: 90 dB)
<b>Frequency response</b>	
PHONO	RIAA standard curve ±0.8 dB (30 Hz~15 kHz)
CD, VCR 1, VCR 2, TAPE	7 Hz~40 kHz (±3 dB)
<b>Bass</b>	50 Hz, +10 dB~-10 dB
<b>Treble</b>	20 kHz, +10 dB~-10 dB

<b>Loudness control (volume at -30 dB)</b>	50 Hz, +9 dB
<b>Output voltage</b>	
VCR 1 AUDIO OUT, TAPE REC OUT	200 mV
<b>Channel balance, 250 Hz~6,300 Hz</b>	±1 dB
<b>Channel separation</b>	55 dB
<b>Headphones output level and impedance</b>	430 mV/330 Ω
<b>Load impedance</b>	
A or B	4 Ω~16 Ω
A and B	8 Ω~16 Ω

### ■ FM TUNER SECTION

<b>Frequency range</b>	87.50~108.00 MHz
<b>Sensitivity</b>	
S/N 30 dB	1.5 μV (75 Ω)
S/N 26 dB	1.3 μV (75 Ω)
S/N 20 dB	1.2 μV (75 Ω)
<b>IHF usable sensitivity</b>	1.5 μV (IHF'58, 75 Ω)
<b>IHF 46 dB stereo quieting sensitivity</b>	22 μV/75 Ω
<b>Total harmonic distortion</b>	
MONO	0.2 %
STEREO	0.3 %
<b>S/N</b>	
MONO	60 dB (75 dB, IHF)
STEREO	58 dB (71 dB, IHF)
<b>Frequency response</b>	20 Hz~15 kHz, +1 dB~-2 dB

# Technics

Matsushita Electric Industrial Co., Ltd.  
Central P.O. Box 288, Osaka 530-91, Japan

Alternate channel selectivity	65 dB
Capture ratio	1.0 dB
Image rejection at 98 MHz	40 dB
IF rejection at 98 MHz	70 dB
Spurious response rejection at 98 MHz	70 dB
AM suppression	50 dB
Stereo separation	
1 kHz	40 dB
Carrier leak	
19 kHz	-55 dB (-60 dB, IHF)
38 kHz	-50 dB (-55 dB, IHF)
Channel balance (250 Hz~6,300 Hz)	±1.5 dB
Limiting point	1.2 μV
Bandwidth	
IF amplifier	180 kHz
FM demodulator	1000 kHz
Antenna terminals	75 Ω (unbalanced)

## ■ AM TUNER SECTION

Frequency range	522 kHz~1611 kHz (9-kHz steps) 530 kHz~1620 kHz (10-kHz steps)
Sensitivity (S/N 20 dB)	20 μV, 330 μV/m

Selectivity (±9kHz) (at 999 kHz)	55 dB
Image rejection (at 999 kHz)	40 dB
IF rejection (at 999 kHz)	55 dB

## ■ GENERAL

Power consumption	360 W
Power supply	AC 50 Hz/60 Hz, 220 V
Dimensions (W × H × D)	430 × 124 × 300 mm
Weight	6.5 kg

### Note:

- Specifications are subject to change without notice.  
Weight and dimensions are approximate.
- Total harmonic distortion is measured by the digital spectrum analyzer.

## ■ CONTENTS

	Page
ACCESSORIES	2
CONNECTIONS TO EQUIPMENT	3
FRONT PANEL CONTROLS AND FUNCTIONS	4, 5
REMOTE-CONTROL OPERATION	6, 7
PROTECTION CIRCUITRY	7
BEFORE REPAIR AND ADJUSTMENT	7
DISASSEMBLY INSTRUCTIONS	8~12
MEASUREMENTS AND ADJUSTMENTS	12, 13
TERMINAL FUCTION OF IC	14
INTERNAL CONNECTION OF FL	15

	Page
BLOCK DIAGRAM	16 ~ 18
TERMINAL GUIDE OF IC'S, TRANSISTORS AND DIODES	19
SCHEMATIC DIAGRAM	20~27
PRINTED CIRCUIT BOARDS	28~32
WIRING CONNECTION DIAGRAM	33
EXPLODED VIEW	34, 35
REPLACEMENT PARTS LIST	36~39
PACKING	39
RESISTORS & CAPACITORS	40, 41

## ■ ACCESSORIES

● AC power supply cord (1) (SFDAC05E03)	● FM indoor antenna (1) (SSA270M)	● AM loop antenna (1) (SPB1163T)
● AM antenna holder (1) (SMA233-1M)	● Screws (2) (XTN3+10AFZ)	● Remote-control transmitter (1) (RAK-SA301E)
		● Batteries (2) (UM-4NE/2S)

# CONNECTIONS TO EQUIPMENT

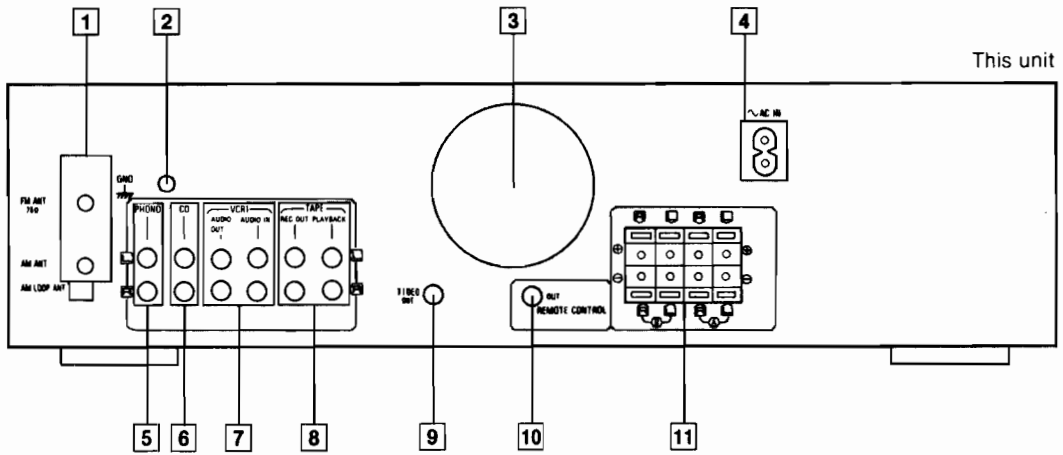

## 1 Antenna connection terminals

## 2 "GND" terminal

Connect the turntable's ground wire to this terminal (if applicable).

## 3 Cooling fan

The cooling fan operates at high output power levels only.

## 4 AC IN socket (AC IN)

Connect this socket to an AC outlet on the wall by using the included AC power supply cord.

## 5 "PHONO" terminals

Connect a turntable only. Do not connect any other sound source to these terminals.

\* Phono input capacitance is about 270pF.

## 6 "CD" terminals

Connect a compact disc player or other sound source.

## 7 "VCR 1" terminals

Connect a video cassette recorder.  
(See the operating instructions of the VCR.)

## 8 "TAPE" terminals

Connect a tape deck.

## 9 "VIDEO OUT" terminal

Connect a video connection cable (not included) to the video input terminal of VCR or TV.

## 10 Remote-control terminal

This terminal can be used only with Technics components which have the appropriate remote-control terminal.  
(Consult your dealer for details.)

Proper connection with remote-control connection cables SJP2257T will allow control of some functions from this unit's remote-control transmitter. (See page 6 for details.)

### OUT:

Connect a tape deck and/or compact disc player as shown below.

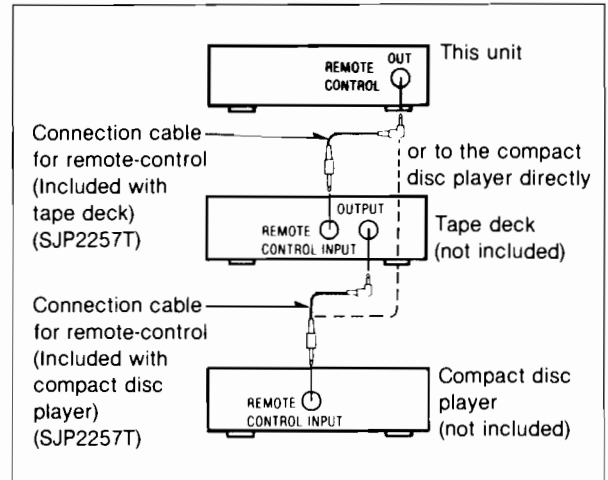

## 11 Speaker connection terminals

# FRONT PANEL CONTROLS AND FUNCTIONS

## Tuner section

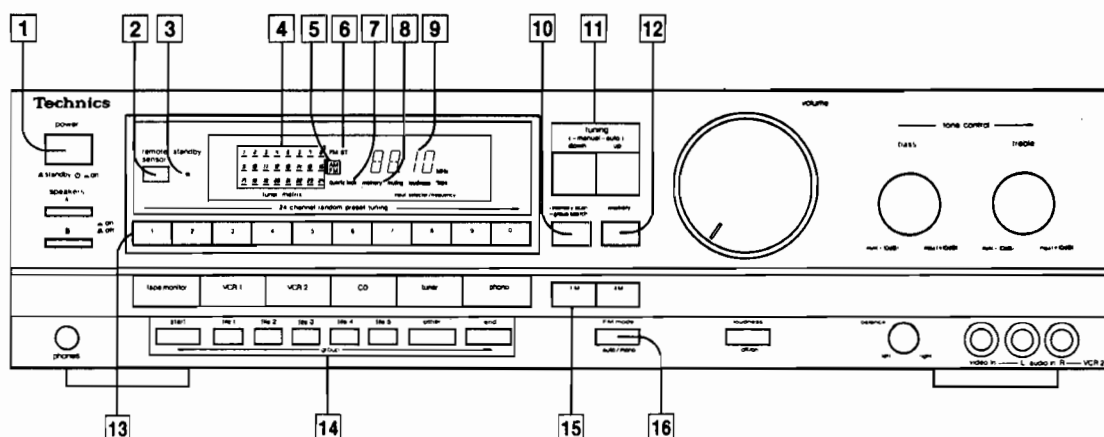

### 1 Power "standby $\phi$ /on" switch (power/ standby $\phi$ = on)

This switch switches ON and OFF the secondary circuit power only. The unit is in the "standby" condition when this switch is set to the standby  $\phi$  position. Regardless of the switch setting, the primary circuit is always "live" as long as the power cord is connected to an electrical outlet.

### 2 Remote-control signal receptor (remote sensor)

Receives the signals from the remote-control transmitter.

### 3 "standby" indicator (standby)

This indicator illuminates when the power switch of this unit or that of the remote control is switched "OFF". Its purpose is to alert the user of the constant supply voltage to the internal circuitry even with the power switch OFF.

### 4 Preset channel matrix display (tuner matrix)

When an entry is made to the memory, the bar under the figure illuminates.  
The bar of the "channel" now being received flashes continuously.

### 5 Band indicators (AM/FM)

Indicates the selected band.

### 6 FM stereo indicator (AM/FM)

This indicator automatically illuminates when an FM stereo broadcast is being received.

#### Note:

It will not illuminate if the FM mode selector is set to the monaural mode.

### 7 Quartz-lock indicator (quartz lock)

This indicator illuminates when the unit is tuned precisely to a broadcast station.

### 8 Memory indicator (memory)

This indicator illuminates when the memory button is pressed.

### 9 Audio input selector/frequency display (input selector/frequency)

Displays the selected source or broadcast frequency.

### 10 Memory-scan/group-search button (-memory scan/-group search)

This button is used to scan the memory presets within a group (for about three seconds each) or to search for the desired group.

### 11 Tuning buttons (tuning)

These buttons are used for tuning to the desired broadcast station.

### 12 Memory button (memory)

This button is used when presetting broadcast station frequencies into memory.

### 13 Preset-tuning buttons (1-0) (24 channel random preset tuning)

These buttons are used to preset broadcast frequencies into the memory of this unit, and to recall the desired preset stations.

### 14 Group registration buttons (group)

These buttons are used to assign memory presets to the desired group or to select the desired group.

### 15 Band selectors

**FM:** Press this button to listen to an FM broadcast.

**AM:** Press this button to listen to an AM broadcast.

**allocation:** When the AM button is pressed for about 4 seconds, the AM frequency step will change to 10 kHz per step. (This step is set to 9 kHz before shipment.) In order to return to the original frequency indication, press this button for about 4 seconds again.

### 16 FM mode selector (FM mode)

This unit automatically switches to the stereo mode when an FM stereo broadcast is received. This selector is used to select the mode (stereo or monaural) of FM broadcast signals.

## Amplifier section

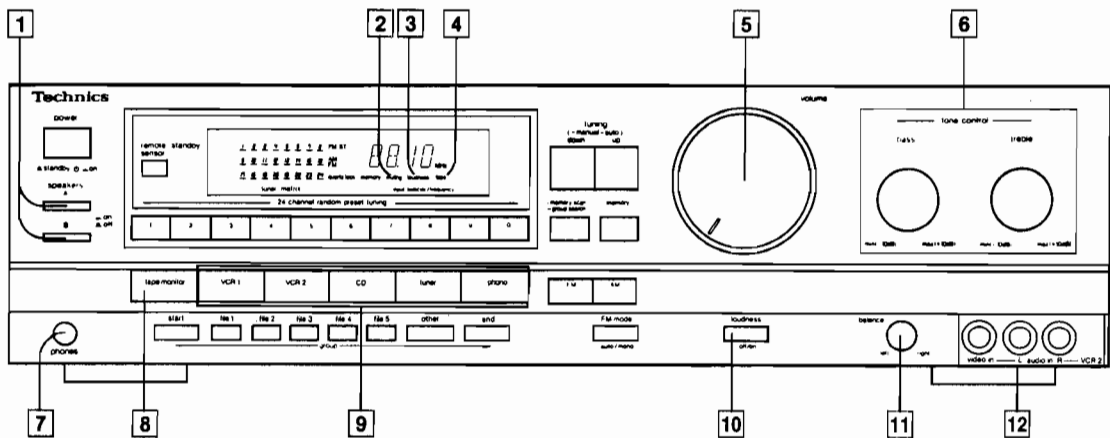

### 1 Speaker selectors (speakers)

These selectors are used to select the speaker system(s) (A and/or B).

### 2 Muting indicator (muting)

This indicator will illuminate when the muting button (on the remote-control transmitter) is pressed.

To cancel the muting function without using the remote-control transmitter, press and hold the "phono" input selector of this unit for about 5 seconds.

#### Note:

The unit will switch to the phono mode.

### 3 Loudness indicator (loudness)

This indicator will illuminate when the loudness switch is pressed.

### 4 Tape indicator (tape)

This indicator will illuminate when the tape-monitor switch is pressed.

### 5 Volume control (volume)

### 6 Tone controls (bass/treble)

The bass control is used to adjust the low-frequency sound range, and the treble control is used to adjust the high-frequency sound range.

### 7 Headphone jack (phones)

### 8 Tape-monitor switch

Press this button to listen to a tape.

No other source selected by an input selector can be heard while the tape indicator is illuminated. To listen to some other source, press this switch once again.

### 9 Input selector buttons

These buttons are used to select the sound source to be heard, such as a disc, radio broadcasts, etc. The selected sound source is shown on the audio input selector/frequency display.

### 10 Loudness switch (loudness)

Set to the "on" position (the loudness indicator will illuminate); when listening to music at low volume. Auditory perception of sound in the low frequency range falls off at low volume, but when the switch is in this position, this deficiency is compensated for, so that the full impact of the musical performance can be enjoyed.

### 11 Balance control (balance)

### 12 "VCR 2" terminals (VCR 2)

These terminals are used for tape-to-tape recording if a second VCR is connected here.

## REMOTE-CONTROL OPERATION

- This remote-control transmitter can be used for control of a Technics cassette tape deck or a compact disc player with a remote-control terminal.

Consult your dealer for details.

- For detailed information concerning operation steps, etc., please refer to the appropriate page for each unit and the respective operating instructions.

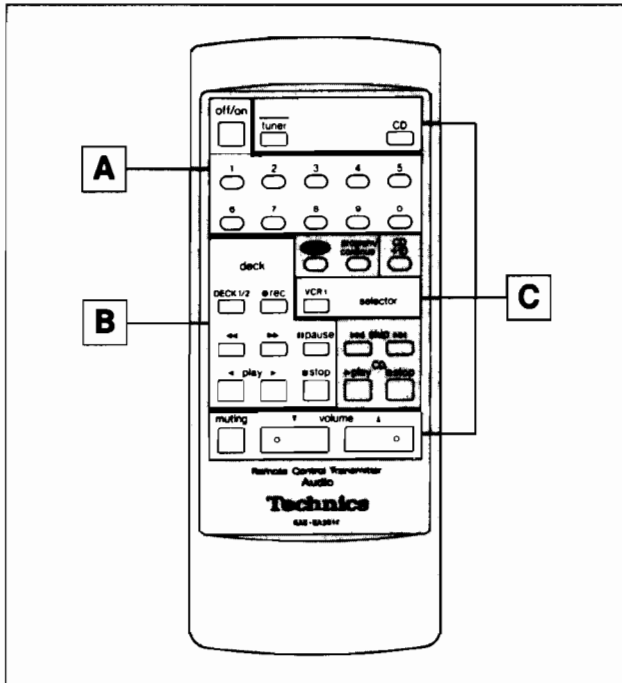

### Before beginning

Make sure that the power switch of each unit is set to the "on" position.

### A Tuner controls

**off/on** This key can be used for ON and OFF switching of this unit.

When switching the power ON and OFF, be sure to first press the "tuner" button on amplifier controls.

**1** - **0** Press this key to select the desired preset channel.

When these buttons are used, be sure to first press the "tuner" button on amplifier controls.

- To designate channels 1–9:** Press the appropriate (1–9) preset-tuning button.

**Note:** When selecting channel 1 or channel 2, enter the selection "01" or "02". If only "1" or "2" is pressed, channel access will be delayed by two seconds.

- To designate channels 10–24:**

- Press the button for the left digit (1 or 2).
- Press the button for the right digit (1–0) within 2 seconds after pressing the first button.

**Example:** To designate channel 12

Press the "1" button and then the "2" button.

### B Tape deck controls

**DECK 1/2** Press this key to select the deck (tape deck 1 or tape deck 2) to be used.

**PLAY** **▶**: For the "A"-side of the tape  
**◀**: For the "B"-side of the tape

Press one of these keys to begin the playback or recording, pressing the key corresponding to the side of the tape to be played (or recorded).

**Note:** Depending on which Technics tape deck is used in combination with this unit, tape deck 1 might be the "A"-side playback-only type.

**deck stop** Press this key to stop tape movement.



Press this key to advance or rewind the tape while the unit is in the stop mode.

Press this key to select the desired tune while the unit is in the play mode.

(Only applicable to a Technics tape deck with the "music select" functions.)

**pause** Press this key to temporarily stop playback or recording. Press the playback key to resume the play or recording.

**REC** Press this key to change to the recording stand-by mode.

#### Note

Depending on which Technics tape deck is used in combination with this unit, it might be that pause of the playback (and the recording), and the recording functions of tape deck 1 not be possible by using the remote-control transmitter.

### C Amplifier controls

**tuner** **CD** These sound keys are used to select the source (radio broadcasts or compact disc) to be heard.

**muting** Press this key to temporarily reduce the volume level. The volume level is attenuated by 20 dB (approx. 1/10). Press once again to return to the previous volume level.

**volume** Press this key to adjust the volume level.

**VCR 1** Press this key when a TV broadcast is to be received at the VCR.

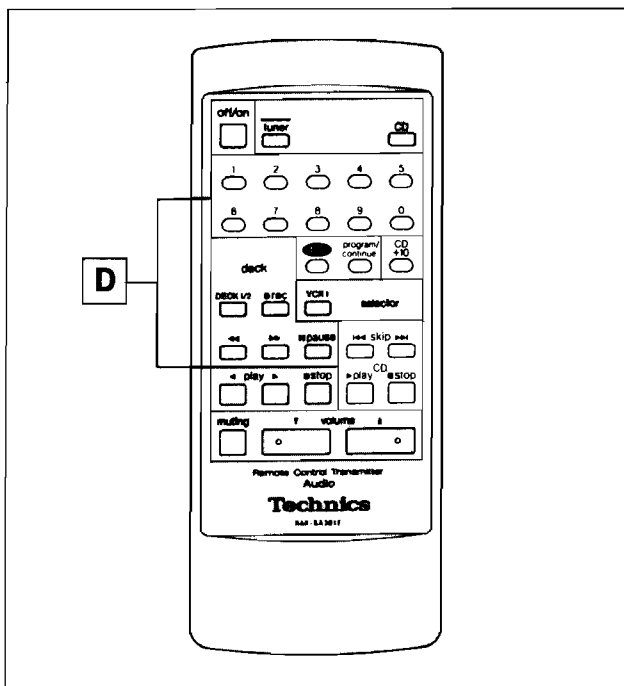

## D Compact disc player controls

 Press this key to start the play.



 Press this key to stop the play.

Press one of these buttons briefly to move the pick-up to the beginning of a specific track.

 If a Technics multi compact-disc player is used in combination with this unit, the disc to be played can be selected by first pressing this button and then pressing the appropriate "numeric button".

 Press to select the desired play mode. ("program" or "continue")

  These buttons can be used to select track number.

When these buttons are used, be sure to first press the "CD" button on amplifier controls.

### Note:

To select a track number 10 or higher in the direct access play or program play mode, first press the "+10" button the necessary number of times and then press the appropriate "numeric button".

## PROTECTION CIRCUITRY

The protection circuitry may have operated if either of the following conditions is noticed:

- No sound is heard when the power is turned on.
- Sound stops during a performance.

The function of this circuitry is to prevent circuitry damage if, for example, the positive and negative speaker connection wires are "shorted", or if speaker systems with an impedance less than the indicated rated impedance of the amplifier are used.

If this occurs, follow the procedure outlines below:

1. Turn off the power.
2. Determine the cause of the problem and correct it.
3. Turn on the power once again after one minute.

### Note:

When the protection circuitry functions, the unit will not operate unless the power is first turned off and then on again.

## BEFORE REPAIR AND ADJUSTMENT

- (1) Turn off the power supply. Using a 10Ω, 5W resistor connect both ends of power supply capacitors (C701, C702, 8200μF) in order to discharge the voltage.
- (2) Before turning the power supply on, after completion of repair, slowly apply the primary voltage by using a power supply voltage controller to make sure that the consumed current at 50Hz/60Hz in NO SIGNAL mode should be shown below with respect to supply voltage 220V.

Power supply voltage	AC220V
Consumed current 50/60Hz	100 ~ 205mA

## DISASSEMBLY INSTRUCTIONS

### "ATTENTION SERVICER"

Some chassis components may have sharp edges. Be careful when disassembling and servicing.

#### Ref. No. 1 Removal of the cabinet

##### Procedure 1

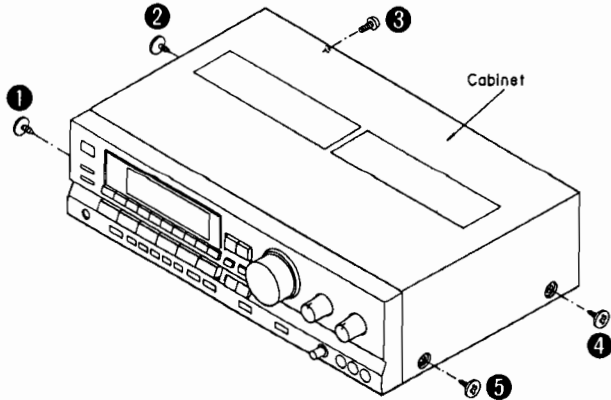

- Remove the 5 screws (①~⑤).

#### Ref. No. 3 Removal of the power switch P.C.B.

##### Procedure 1→2→3

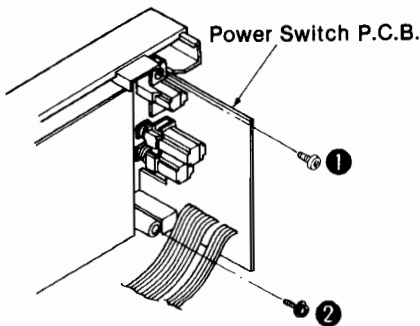

- Remove the 2 screws (①, ②).

#### Ref. No. 4 Removal of the volume P.C.B.

##### Procedure 1→2→4

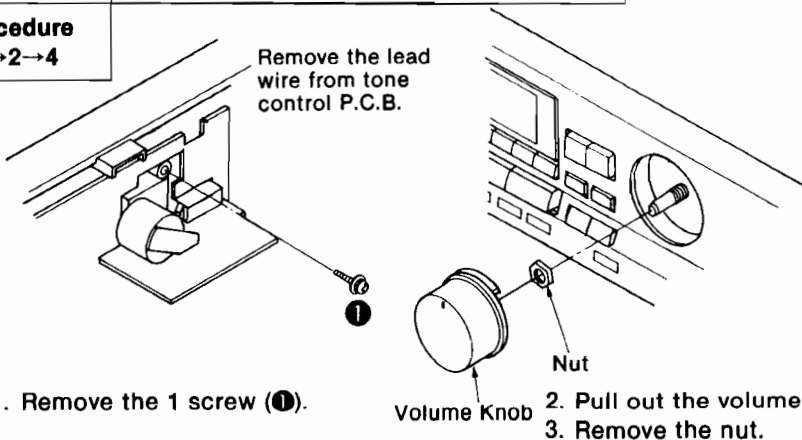

1. Remove the 1 screw (①).

2. Pull out the volume knob.
3. Remove the nut.

4. Remove the volume P.C.B. in the direction of the arrow.

#### Ref. No. 2 Removal of the front panel

##### Procedure 1→2

1. Remove the 2 flat cables (CN601, CN602)

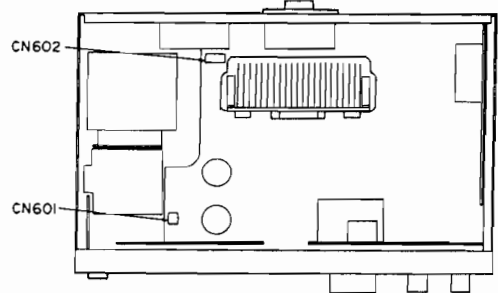

2. Remove the 3 screws (①~③).
3. Remove the front panel in the direction of the arrow.

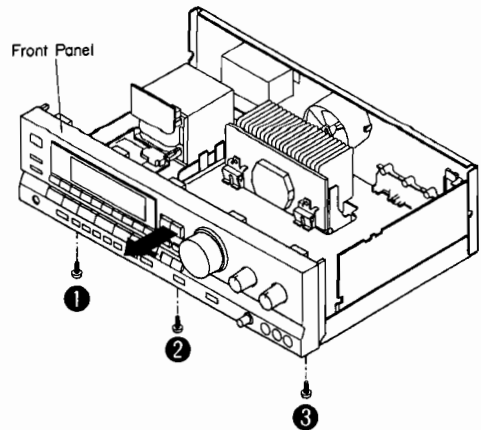

#### How to remove the flat cable

1. Lift the connector.
2. Pull out the flat cable.

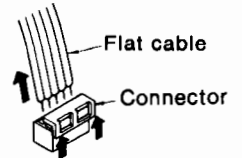

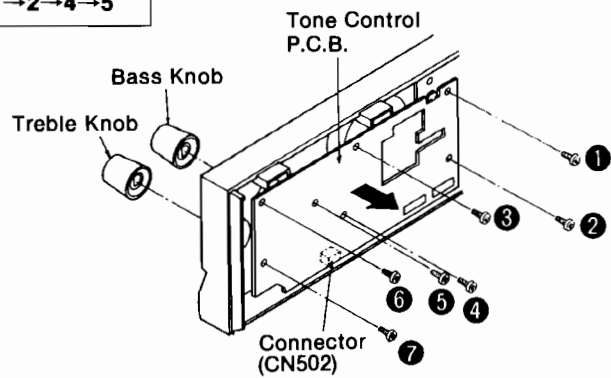
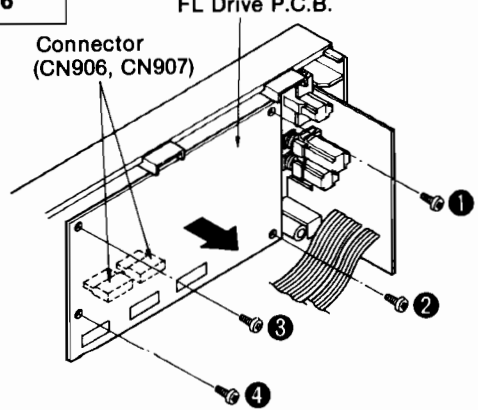

<b>Ref. No.</b> 5	<b>Removal of the tone control P.C.B.</b>	<b>Ref. No.</b> 6	<b>Removal of the FL drive P.C.B.</b>
<b>Procedure</b> 1→2→4→5			<b>Procedure</b> 1→2→6
 <ol style="list-style-type: none"> <li>1. Pull out the bass knob and treble knob.</li> <li>2. Remove the 7 screws (①~⑦).</li> <li>3. Remove the tone control P.C.B. in the direction of the arrow. (Take care of CN502.)</li> </ol>		 <ol style="list-style-type: none"> <li>1. Remove the 4 screws (①~④).</li> <li>2. Remove the FL drive P.C.B. in the direction of the arrow. (Take care of CN906, CN907.)</li> </ol>	

<b>Ref. No.</b> 7	<b>Removal of the operation P.C.B., balance VR P.C.B. and VCR 2 jack P.C.B.</b>
<b>Procedure</b> 1→2→4→5 →6→7	<p>■ <b>Balance VR P.C.B.</b></p> <ol style="list-style-type: none"> <li>1. Pull out the balance knob.</li> <li>2. Remove the 1 screw (①).</li> </ol>

<p>■ <b>Operation P.C.B.</b></p> <ol style="list-style-type: none"> <li>1. Remove the 8 screws (②~⑨).</li> <li>2. Release the 5 claws.</li> </ol>	
<p>■ <b>VCR 2 jack P.C.B.</b></p> <ol style="list-style-type: none"> <li>1. Remove the 2 screws (⑩, ⑪).</li> </ol>	

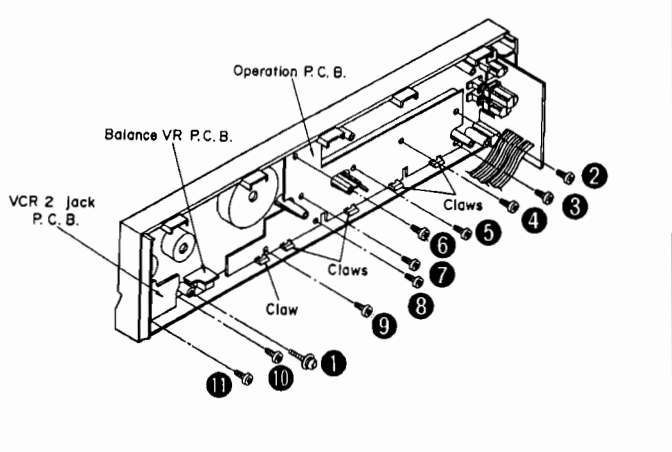
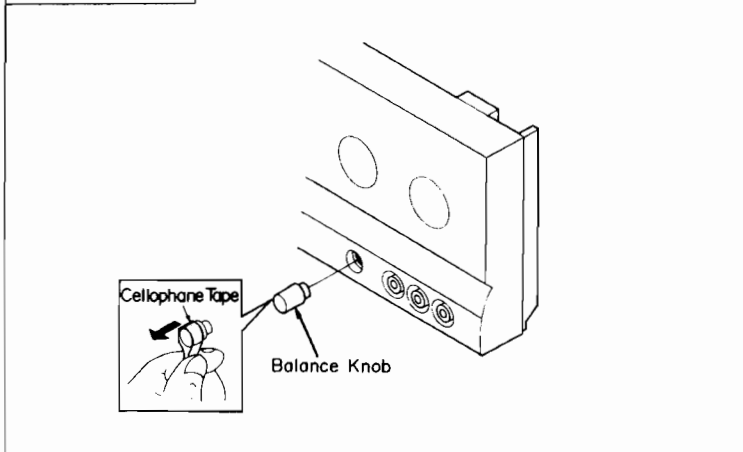

<b>Ref. No.</b> 8	<b>Removal of the remote sensor P.C.B.</b>
<b>Procedure</b> 1→2→6→8	

• Remove the remote sensor P.C.B. in the direction of the arrow.

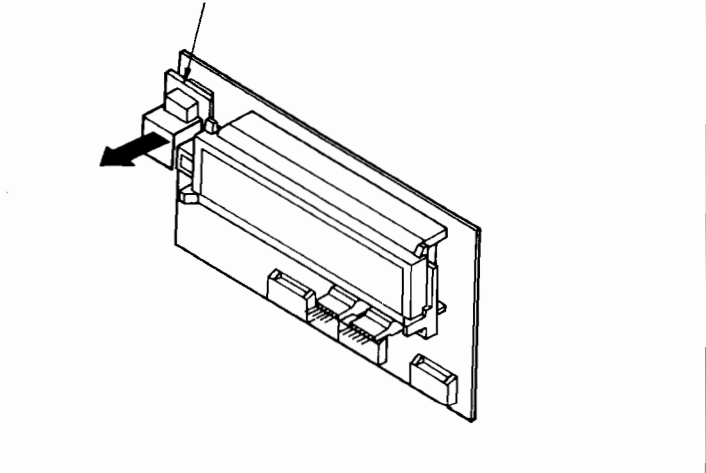

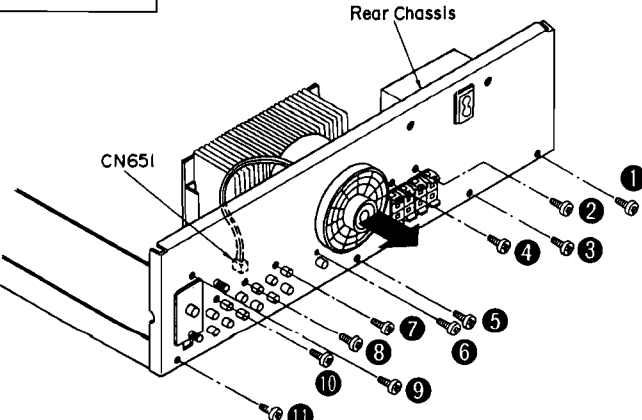
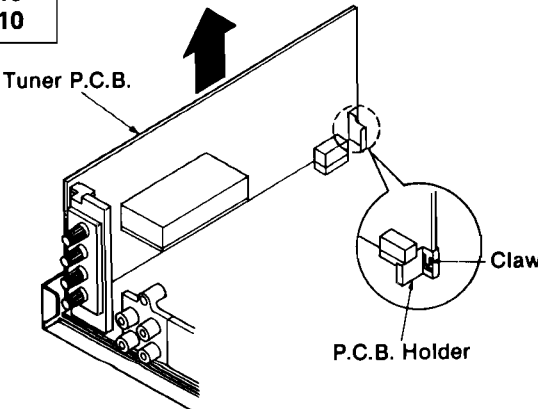
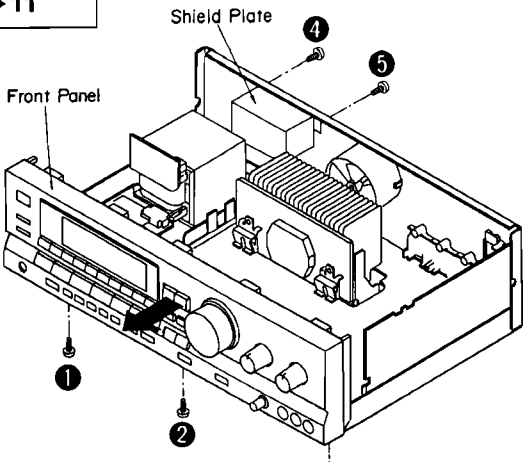
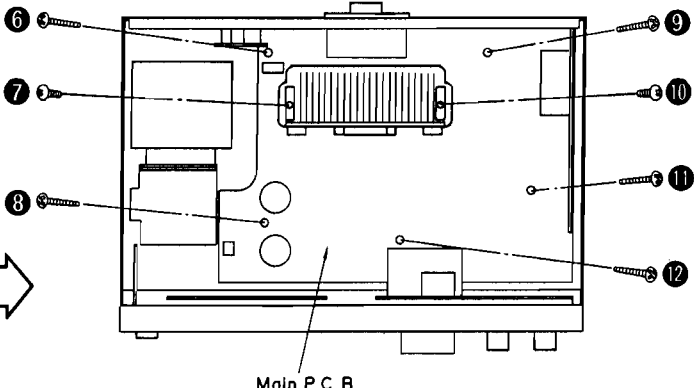
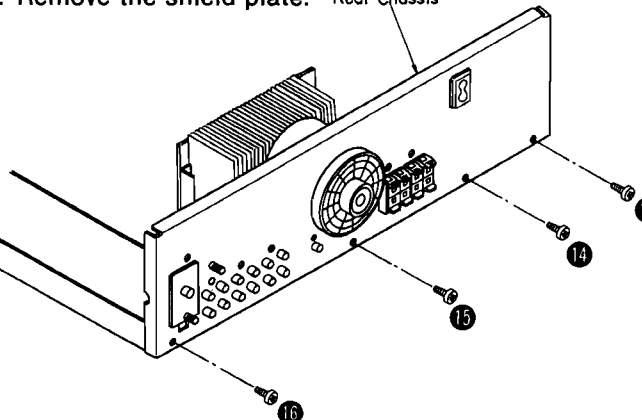
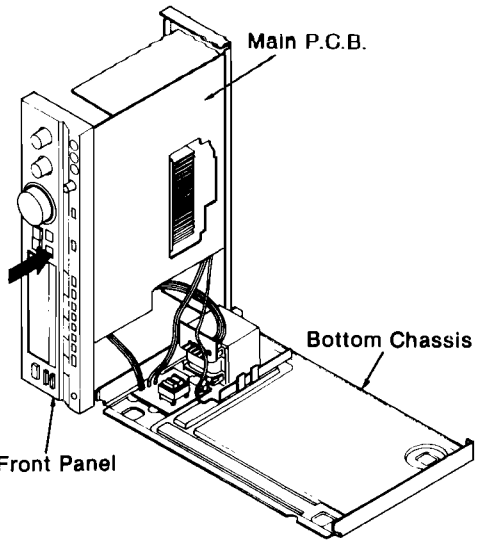
<b>Ref. No.</b> 9	<b>Removal of the rear chassis</b>	<b>Ref. No.</b> 10	<b>Removal of the tuner P.C.B.</b>
<b>Procedure</b> 1→9	1. Remove the 1 connector (CN651). 2. Remove the 11 screws (①~⑪).	<b>Procedure</b> 1→9→10	
 <p>3. Remove the rear chassis in the direction of the arrow.</p>		 <p>1. Release the 1 claw. 2. Remove the tuner P.C.B. in the direction of the arrow.</p>	
<b>Ref. No.</b> 11	<b>How to check the main P.C.B.</b>		
<b>Procedure</b> 1→11			
 <p>1. Remove the 3 screws (①~③).</p>		 <p>5. Remove the 7 screws (⑥~⑫).</p>	
 <p>6. Remove the 4 screws (⑬~⑯).</p>		 <p>7. Remove the bottom chassis. 8. Reinstall the front panel to the main P.C.B.</p>	

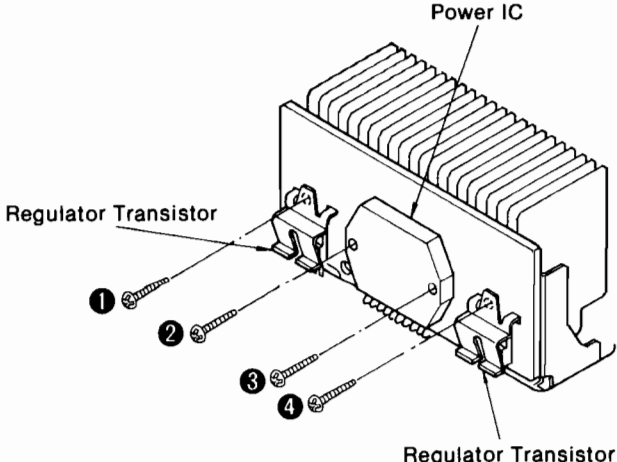
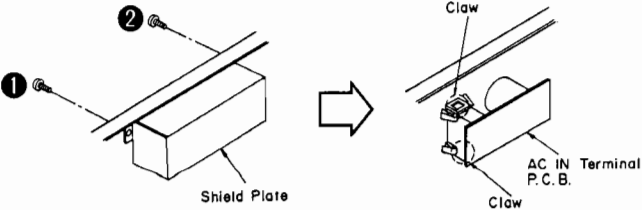
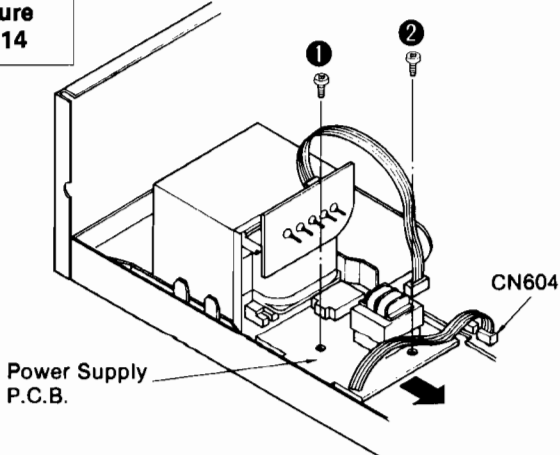
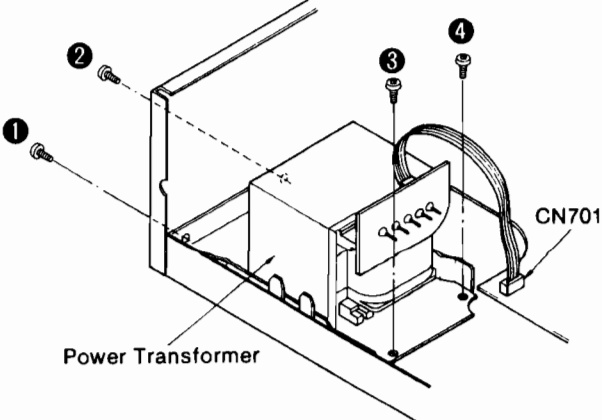
<b>Ref. No.</b> 12	<b>Removal of the power IC and regulator transistor</b>	<b>Ref. No.</b> 13	<b>Removal of the AC IN TERMINAL P.C.B.</b>
<b>Procedure</b> 1→11→12	<ol style="list-style-type: none"> <li>1. Unsolder the power IC or regulator transistor.</li> <li>2. Remove the 4 screws (①~④).</li> </ol>	<b>Procedure</b> 1→9→13	
	 <p>•When mounting the power IC or regulator transistor, apply silicon thermal compound (SZZ0L15 or equivalent) to the rear of the power IC or regulator transistor.</p>		<ol style="list-style-type: none"> <li>1. Remove the 2 screws (①, ②).</li> <li>2. Remove the shield plate.</li> <li>3. Release the 2 claws.</li> </ol>
<b>Ref. No.</b> 14	<b>Removal of the power supply P.C.B.</b>	<b>Ref. No.</b> 15	<b>Removal of the power transformer</b>
<b>Procedure</b> 1→2→14		<b>Procedure</b> 1→2→14→15	
	 <ol style="list-style-type: none"> <li>1. Remove the 1 flat cable (CN604).</li> <li>2. Remove the 2 screws (①, ②).</li> <li>3. Remove the power supply P.C.B. in the direction of the arrow.</li> </ol>		 <ol style="list-style-type: none"> <li>1. Remove the 1 flat cable (CN701).</li> <li>2. Remove the 4 screws (①~④).</li> </ol>

<b>Ref. No.</b> 16	<b>Removal of the fan motor</b>	
<b>Procedure</b> 1→16	<ol style="list-style-type: none"> <li>1. Pull out the 1 connector (CN651).</li> <li>2. Release the 3 claws.</li> </ol>	<ol style="list-style-type: none"> <li>3. Insert a screwdriver at the root of the cooling fan. Force it out of the motor shaft.</li> <li>4. Remove the motor cover by used ⊖ screwdriver.</li> <li>5. Remove the motor from the fan casing.</li> <li>6. When mounting the motor fan, align the fan casing's projection with the hole of the fan motor.</li> </ol>

## MEASUREMENTS AND ADJUSTMENTS

**Note:** For Z201 (AM ANT and OSC coil), Z202 (AM-IFT), Z321 (L.P.F.), L321/L322 (MPX coil) and L324 (L.P.F.), they are supplied as adjusted parts. So, do not turn the cores of the parts.  
It is not necessary to adjust the AM circuit.

### ADJUSTMENT POINTS

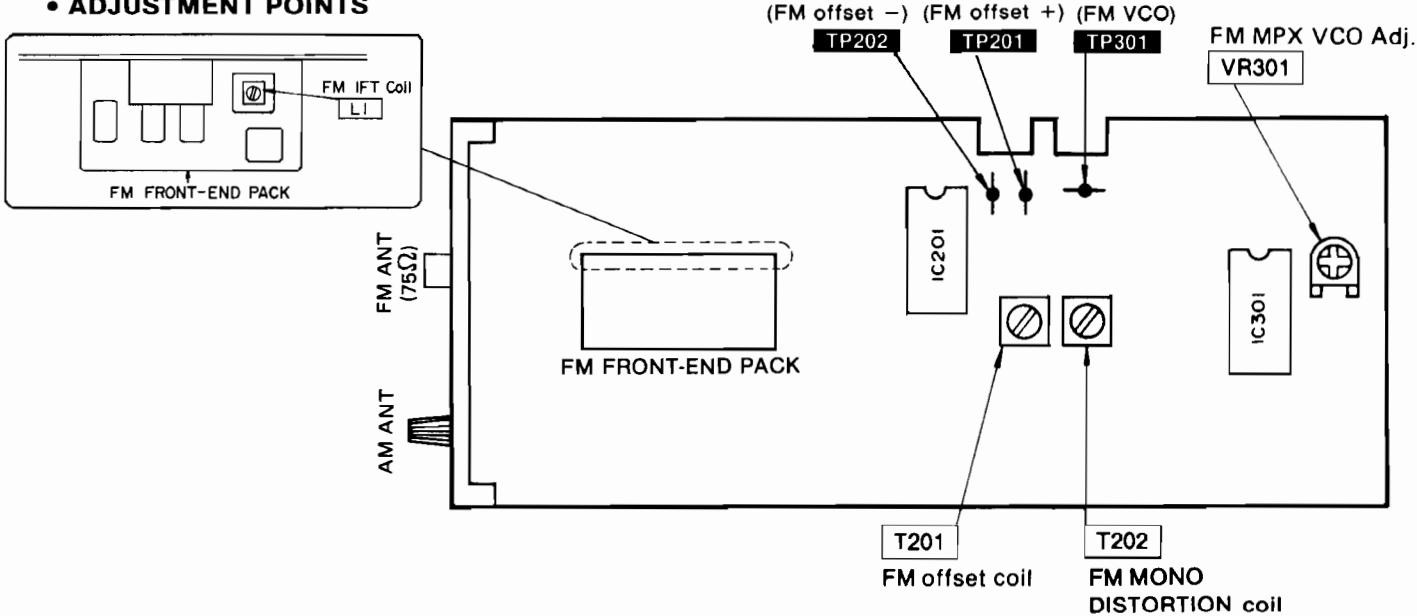

• FM ADJUSTMENT

**Control positions and equipment used**

- FM signal generator (FM-SG).
- Distortion analyser
- Oscilloscope
- DC electronic voltmeter (DC EVM)
- Frequency counter
- Choke coil (100 $\mu$ H)
- Resistor (100k $\Omega$ )

**FM MONO DISTORTION ADJUSTMENT**

1. Test equipment connection is shown in figure.
2. Set the unit to "FM" position.
3. Set the radio frequency display and signal generator to 100.10 MHz.
4. Adjust T201 core so that voltage measured in signal mode is 0mV (0 $\pm$ 20mV) in 300mV range.
5. Adjust T202 so that the distortion factor of Lch is minimized.
6. Repeat steps 4 and 5 a few times.
7. Make sure that the distortion factors of Lch and Rch are nearly the same with each other to minimum.

**Note:**

The adjusting screwdriver used should be made of resin.

**FM SIGNAL GENERATOR CONDITION**

Modulation ..... 100%  
 Modulation frequency..... 1 kHz (MONO)  
 Output level..... 66 dB

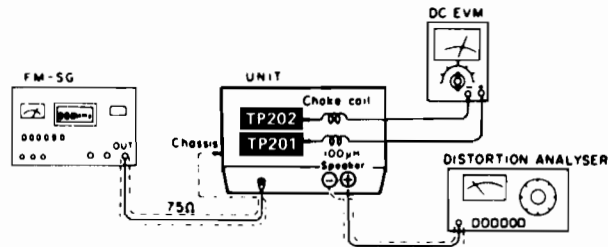

**FM MPX VCO ADJUSTMENT**

1. Test equipment connection is shown in figure.
2. Set the unit to "FM auto" position.
3. Set the radio frequency display and signal generator to 100.10 MHz.
4. Adjust VR301 for 19.00 $\pm$ 0.03 kHz on frequency counter reading.

**FM SIGNAL GENERATOR CONDITION**

Modulation ..... 0% (non-modulation)  
 Output level..... 66 dB

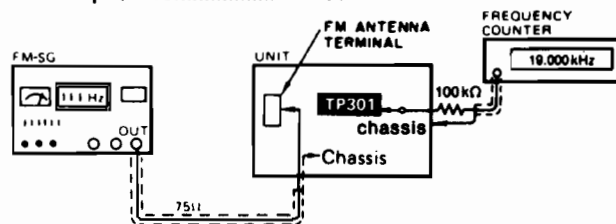

★ **USING ALTERNATE SYSTEM**

1. Apply stereo signal from generator or receive the stereo broadcast.
2. Adjust VR301 until stereo indicator lights up. Cement arm of VR301 as shown in figure.

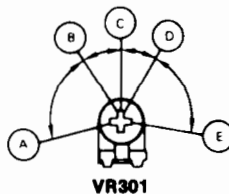

- A - B    D - E : Stereo OFF position
- B - D    : Stereo ON position (indicator lighting)
- C : Adjust point of Pilot circuit

**FM IFT (FM STEREO DISTORTION) ADJUSTMENT**

1. Test equipment connection is shown in figure.
2. Set the unit to "FM" mode.
3. Set the radio frequency display and signal generator to 100.10 MHz.
4. Adjust L1 so that the distortion factor of L-CH is minimized.
5. Make sure that the distortion factors of L-CH and R-CH are nearly the same with each other to minimum.

**Notes:**

1. The adjusting screwdriver used should be made of resin.
2. L1 should be rotated no more 1/4 turn (90 deg.) on either side.

**FM SIGNAL GENERATOR CONDITION**

Modulation..... Stereo "L" mode or "R" mode 100%  
 Modulation frequency ..... 1 kHz (Pilot 19kHz)  
 Output level ..... 66 dB

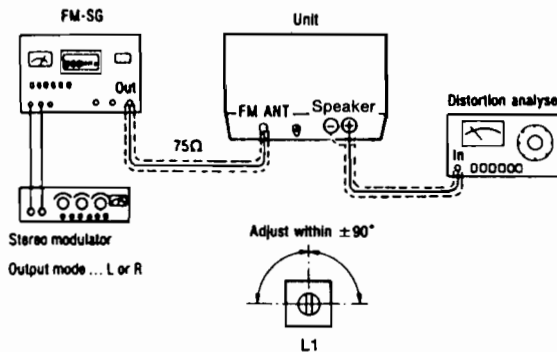

# ■ TERMINAL FUNCTION OF IC

## • IC901 (LC6554H4097): Microcomputer

Pin No.	Mark	I/O Division	Function	Pin No.	Mark	I/O Division	Function
1	S13	O	Segment signal output	33	ST	O	Level shift control output
2 5	PA0 PA3	I	Key return signal input	34	L	—	Not used, connected to GND
6 8	PB0 PB2	I		Key return signal input	35		
9	STAND BY	I	Power supply terminal		36	TUNING 0	O
10	OFF	I	Power ON/OFF det. terminal (Not used, open)	37	TUNING 1		
11	STEREO	I	Stereo signal det. terminal	38	LOUDNESS	O	Loudness ON/OFF signal output
12	SD	I	Received signal det. terminal	39	R	O	Volume motor drive output
13	DP	I/O	Cassette deck control terminal	40	F		
14	RELAY	O	Relay control output	41	A	O	Rotary tuning control signal output (Not used, connected to GND)
15	DECK	I	Cassette deck control terminal (Not used, connected to GND)	42	B		
16	OPT1 (IN)	—	Not used, connected to GND	43	Vp	I	Power supply terminal (negative voltage)
17	OPT1 (OUT)						
18	MONO	O	FM AUTO/MONO select signal output	44	S1 S12	O	Segment signal output
19	RFM	O	Muting control output for tuner circuit				
20	AT	O	Muting control output for amplifier circuit				
21	AFM	O	Muting control output for amplifier circuit	55	VDD	I	Power supply terminal (positive voltage)
22	TEST	—	Not used, connected to GND				
23	Vss	—	Ground terminal				
24	OSC1	I	Oscillator terminal	56	D1	O	Digit signal and key scan signal output
25	OSC2	O					
26	RES	I	Reset signal input	57			
27	DATA (PF0)	O	Serial data output				
28	CL (PF1)	O	Clock signal terminal for serial data				
29	CE (PF2)	I/O	Chip enable terminal	64	L	—	Not used, connected to GND
30	INT	I	Remote control input				
31	L	—	Not used, connected to GND				
32	L	—	Not used, connected to GND				



# ■ BLOCK DIAGRAM

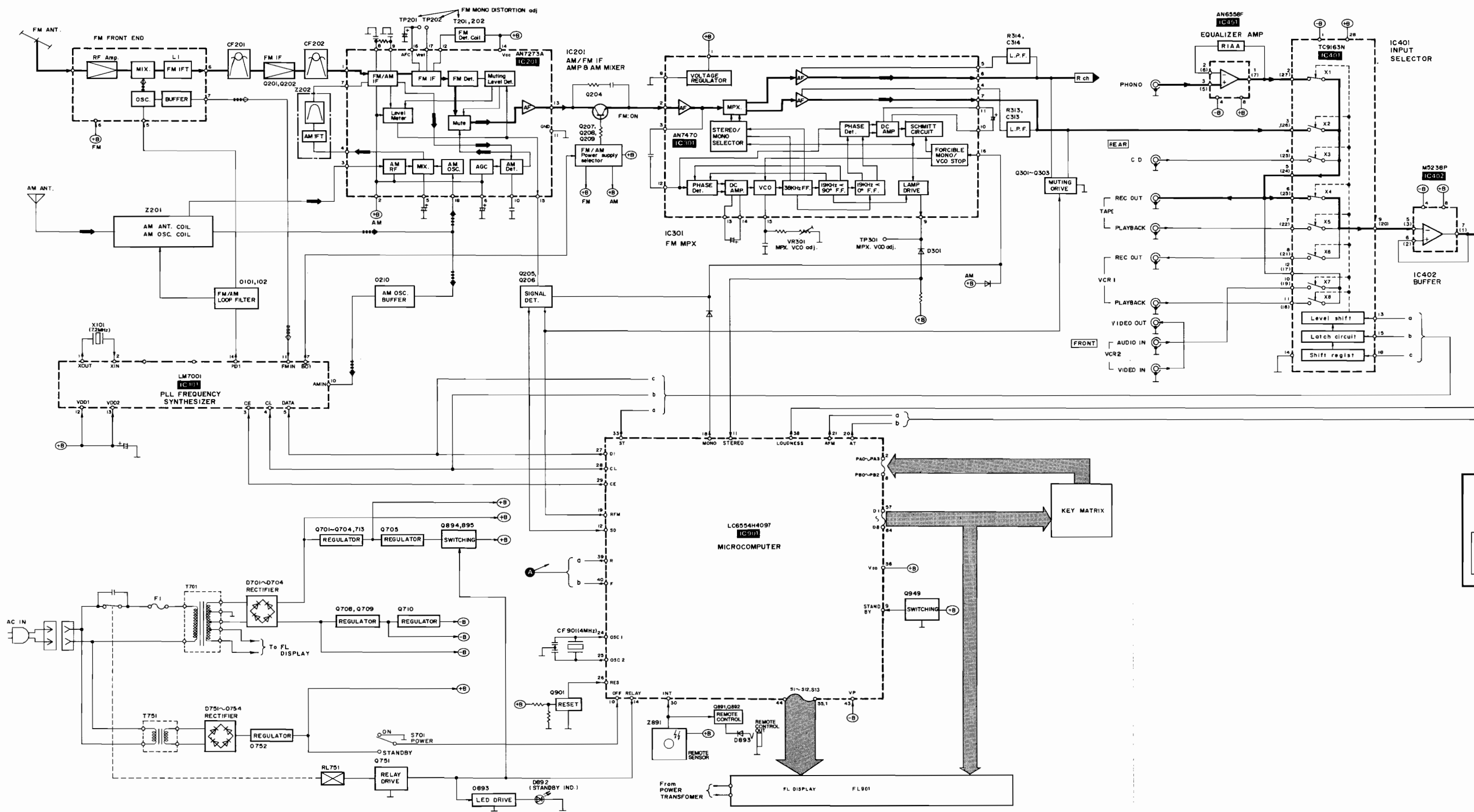



### TERMINAL GUIDE OF IC'S, TRANSISTERS AND DIODES

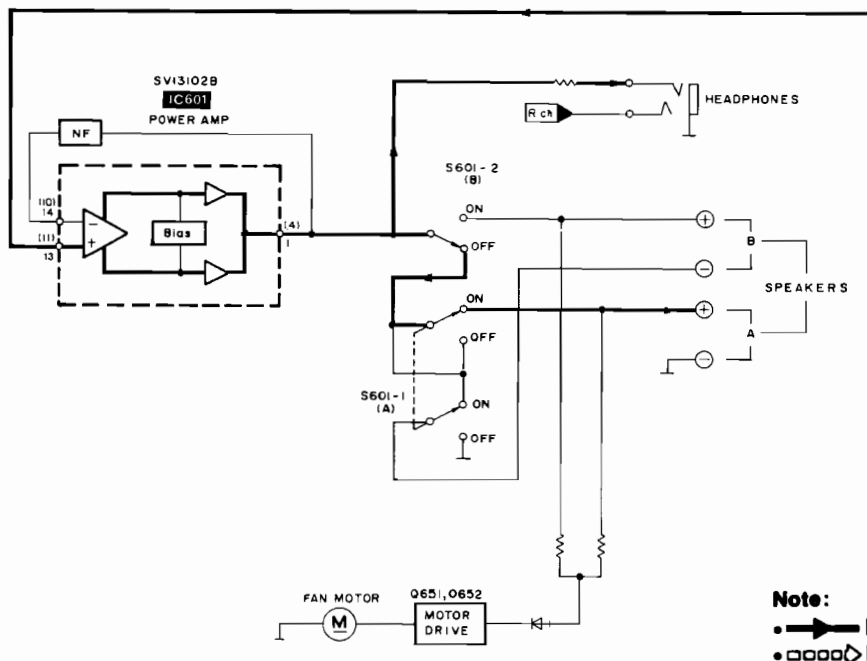
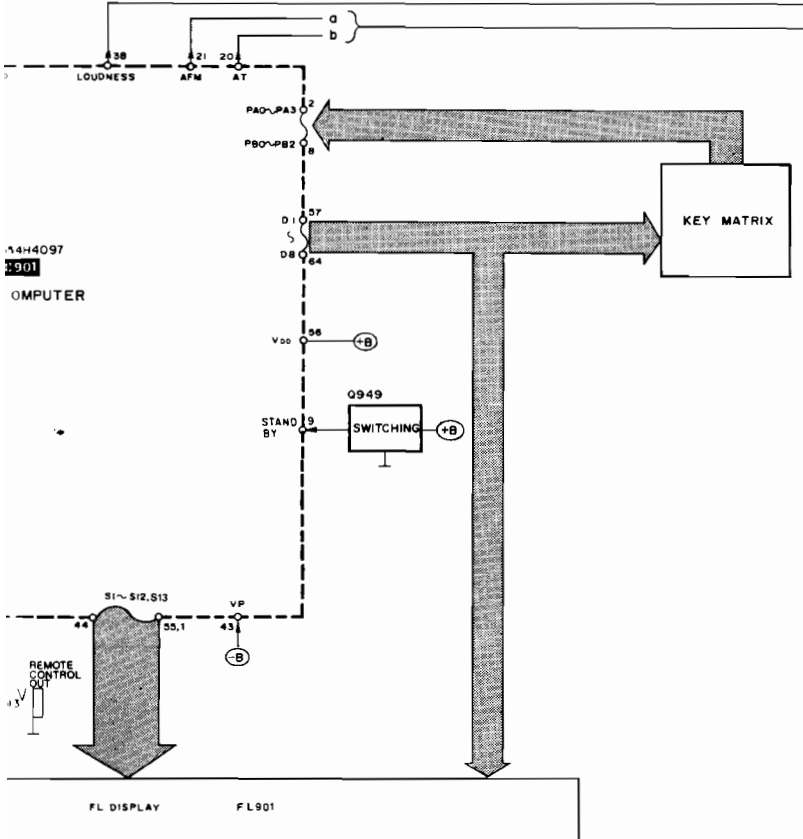
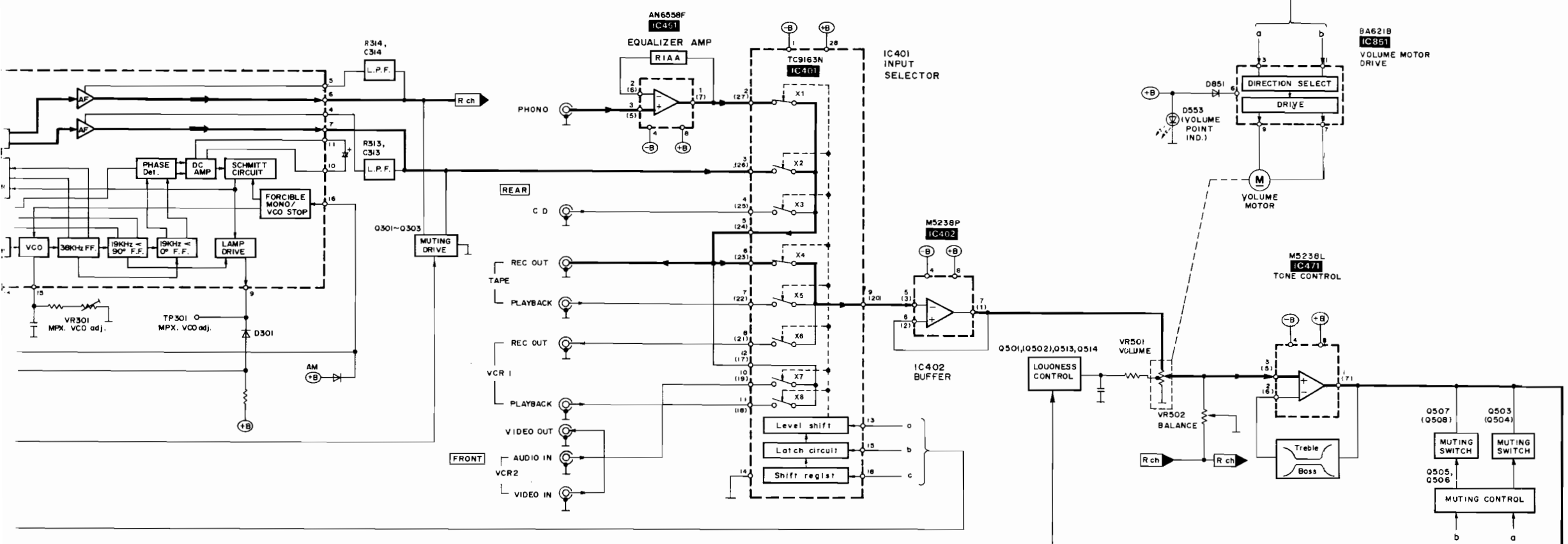

LC6554H4097  
64 PIN

SV13102B  
14 PIN

M5238P	8 PIN	AN7470	16 PIN
AN6558F	8 PIN	AN7273A	18 PIN
LM7001	8 PIN	TC9163N	28 PIN

BA6218	9 PIN
M5238L	8 PIN

2SA933SQRSTA  
2SC2785FETA  
2SC2787LTA  
2SD1450QRSTA  
2SC3327ABTP  
2SC3311AQSTA  
2SA1309AQSTA

2SC1740SQSTA  
2SC3940AQSTA

2SJ40CDTA

UN4113TA

UN4211TA  
UN4214TA

2SB1185DEF  
2SD1761DEF

UN4215TA

2SB1240PRTV6

MA165TA  
MA29WATA  
SVDS5688GT3  
1SS291TA  
P300DLF

LN846RP-LS

MA4051MTA  
MA4062MTA  
MA4150MTA  
MA4068MTA  
MA4110MTA  
MA4270MTA

**Note:**  
 ● FM Signal  
 ● FM OSC  
 ● AM Signal  
 ● AM OSC  
 \* ( ) indicates Pin No. of right channel.

# SCHEMATIC DIAGRAM

(Parts list on pages 37~41.)

(This schematic diagram may be modified at any time with the development of new technology.)

**Note 1:**

- **S601-1, S601-2** : Speaker selectors switch.  
S601-1: A S601-2: B
- **S701** : Power "Standby  $\downarrow$ /on" switch.
- **S901 ~ S910** : Preset-tuning (1-0) switches.  
S901 : CH1, S902 : CH2, S903 : CH3,  
S904 : CH4, S905 : CH5, S906 : CH6,  
S907 : CH7, S908 : CH8, S909 : CH9,  
S910 : CH0
- **S911** : Memory scan/group-search switch.
- **S912** : FM mode selector.
- **S913, S914** : Band selectors.  
S913 : FM, S914 : AM
- **S915, S916** : Tuning switches.  
S915 : down, S916: up
- **S917** : Memory switch.
- **S918** : Loudness switch.
- **S919 ~ S926** : Group registration switches.  
S919 : start, S920 : file 1, S921 : file 2  
S922 : file 3, S923 : file 4, S924 : file 5  
S925 : other, S926 : end
- **S927 ~ S931** : Input selector switches.  
S927 : phono, S928 : tuner, S929 : CD,  
S930 : VCR 1, S931 : VCR 2
- **S932** : Tape-monitor switch.

- **Signal line**

• **Important safety notice:**  
Components identified by  $\Delta$  mark have special characteristics important for safety. When replacing any of these components, use only manufacturer's specified parts. Indicated voltage values are standard values for the unit measured by the DC electronic circuit tester (high-impedance) with the chassis taken as standard. Therefore, there may exist some errors in the voltage values, depending on internal impedance of the DC circuit tester.

• All voltage values shown in circuitry are DC voltage in FM signal (Stereo signal) reception mode.

\* Figures in ( ) stand for DC-voltage in AM signal reception mode.

\* **Caution!**  
IC and LSI are sensitive to static electricity. Secondary trouble can be prevented by taking care during repair.

- \* Cover the parts boxes made of plastics with aluminum foil.
- \* Ground the soldering iron.
- \* Put a conductive mat on the work table.
- \* Do not touch the legs of IC or LSI with the fingers directly.

**Note 2:**

• **Use of ceramic filters in pairs**  
The ceramic filters (CF201, CF202) for FM-IF circuit are available in three ranks. For this circuit, be sure to use the ceramics of the same rank in a pair. At repairing and replacement, pay close attention to the diodes (D914, D915) for use as different diodes must be used depending on each rank of the ceramic filters.

Color marking (Blue, Red or Orange)

RANK (Color)	D914	D915	CENTER FREQUENCY
Blue	○	X	10.675MHz
Red	○	○	10.700MHz
Orange	X	○	10.725MHz

**Note:** ○ mark: Diode is used.  
X mark: Diode is not used.

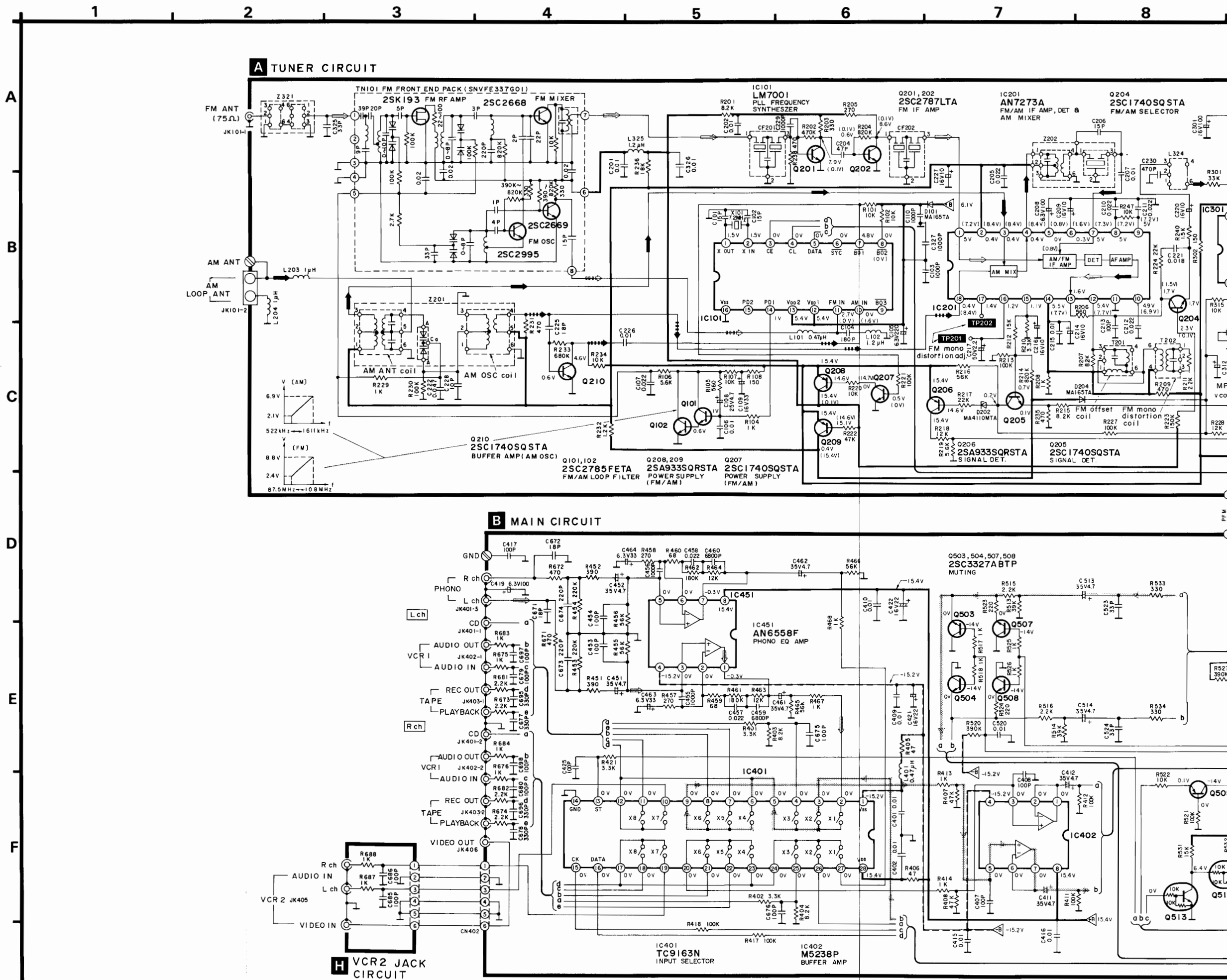

TUNER CIRCUIT

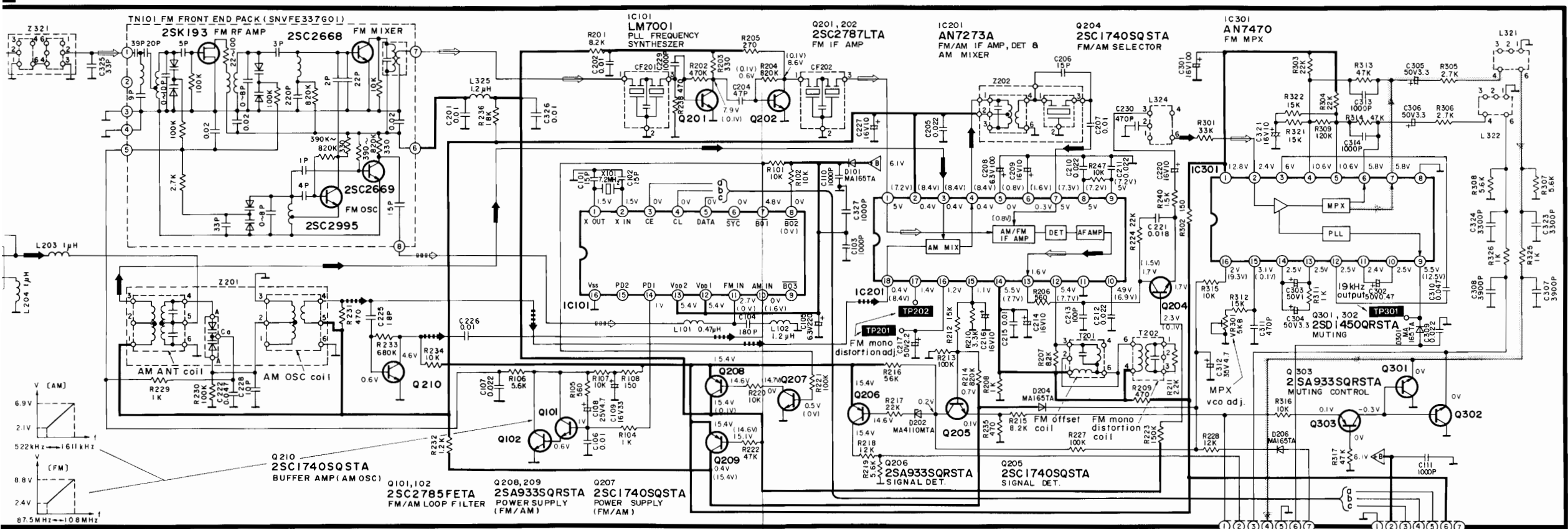

FL DRIVE CIRCUIT

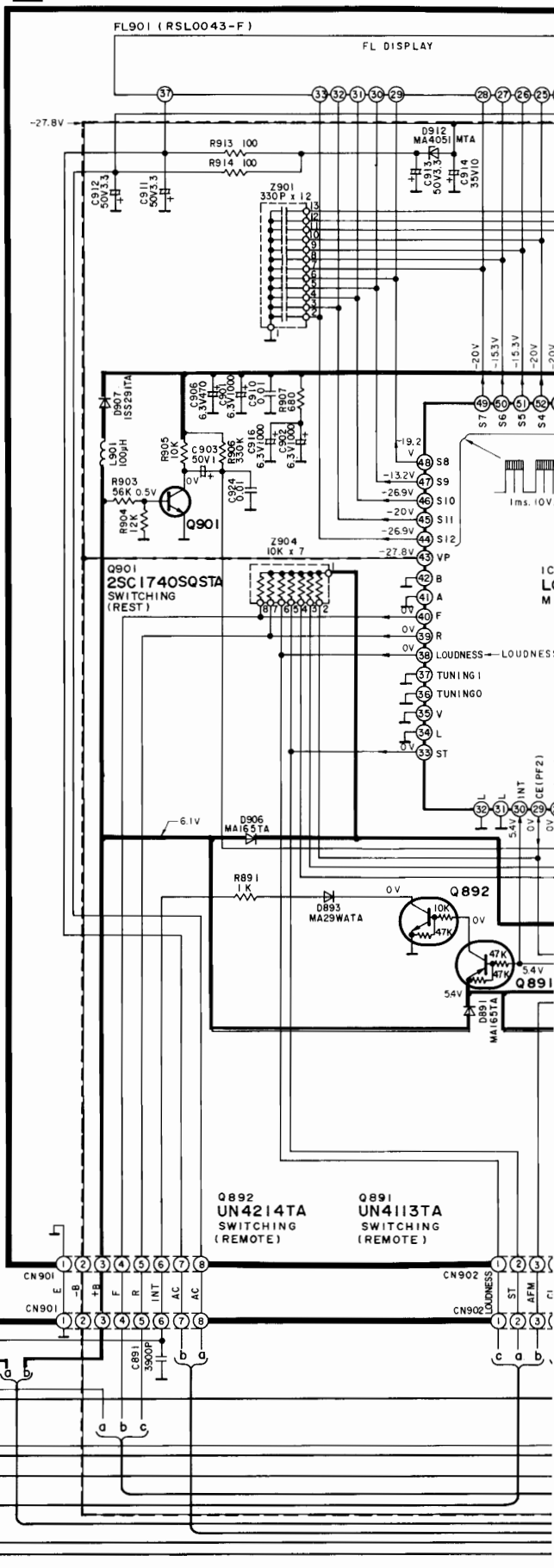

MAIN CIRCUIT

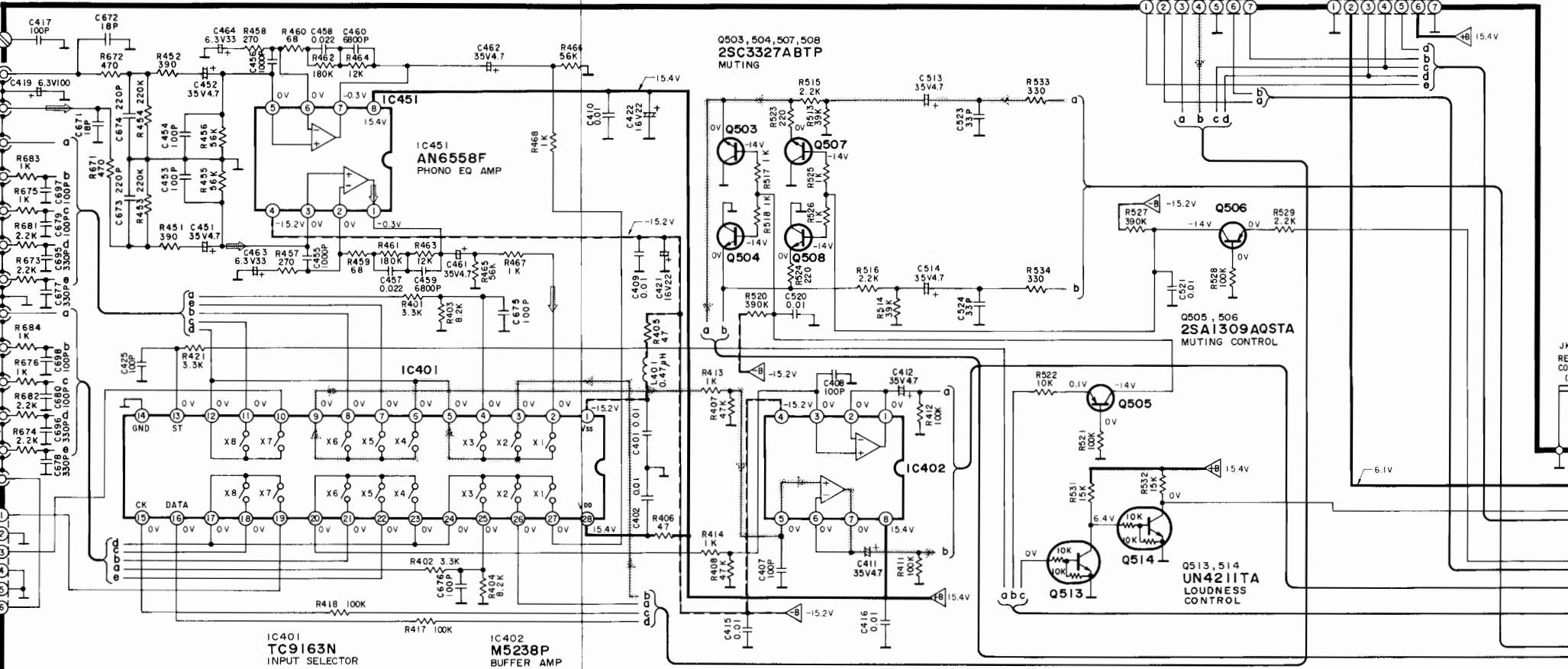

VCR2 JACK CIRCUIT



C FL DRIVE CIRCUIT

D OPERATION CIRCUIT

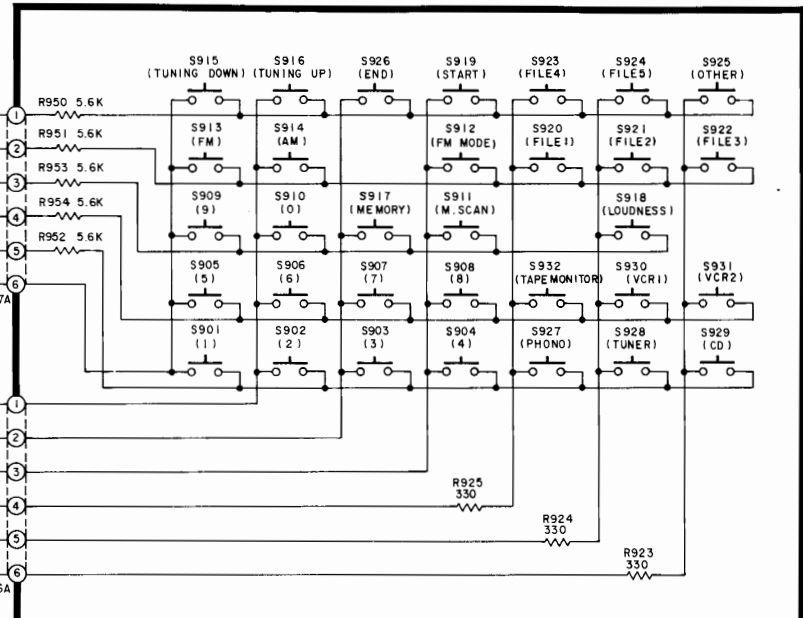
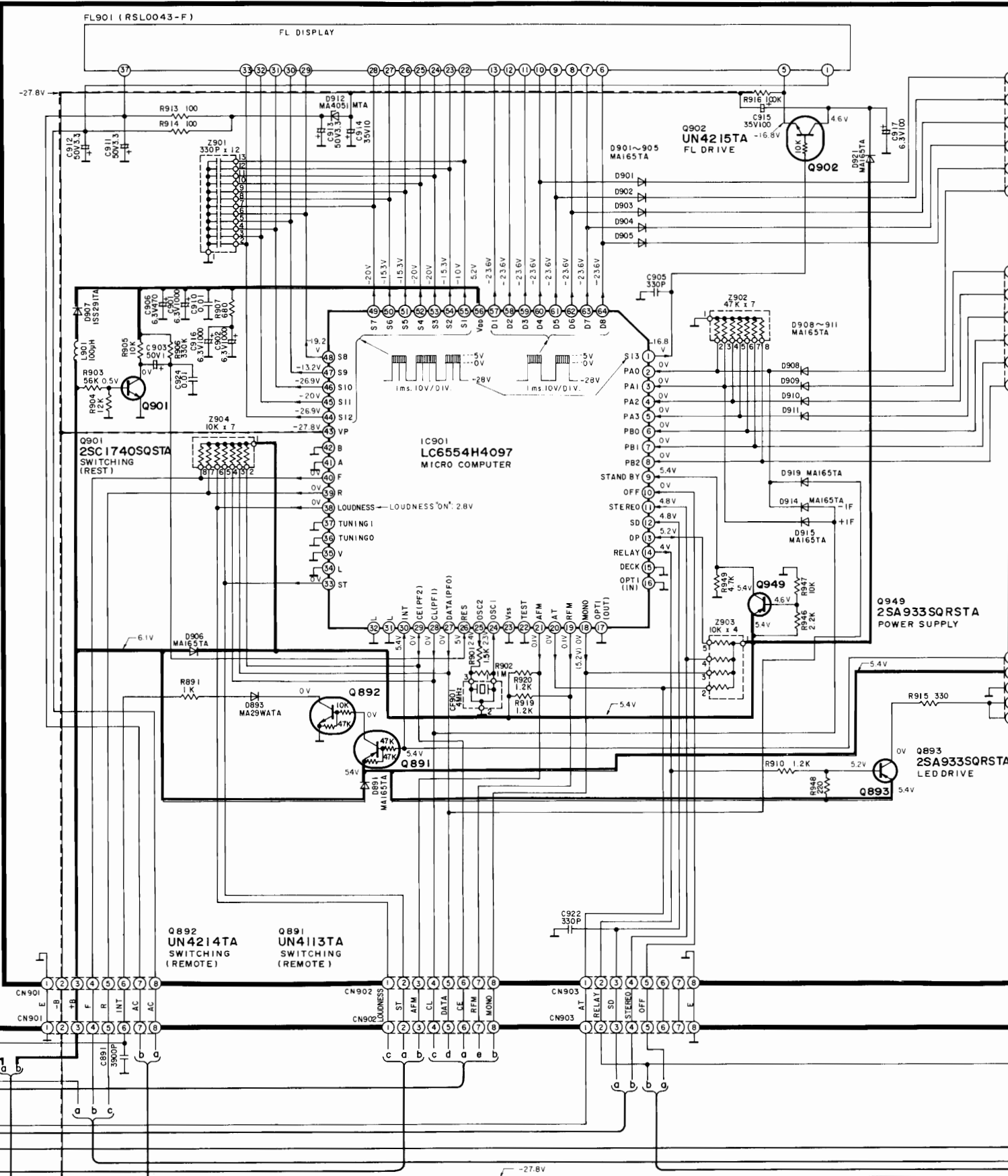
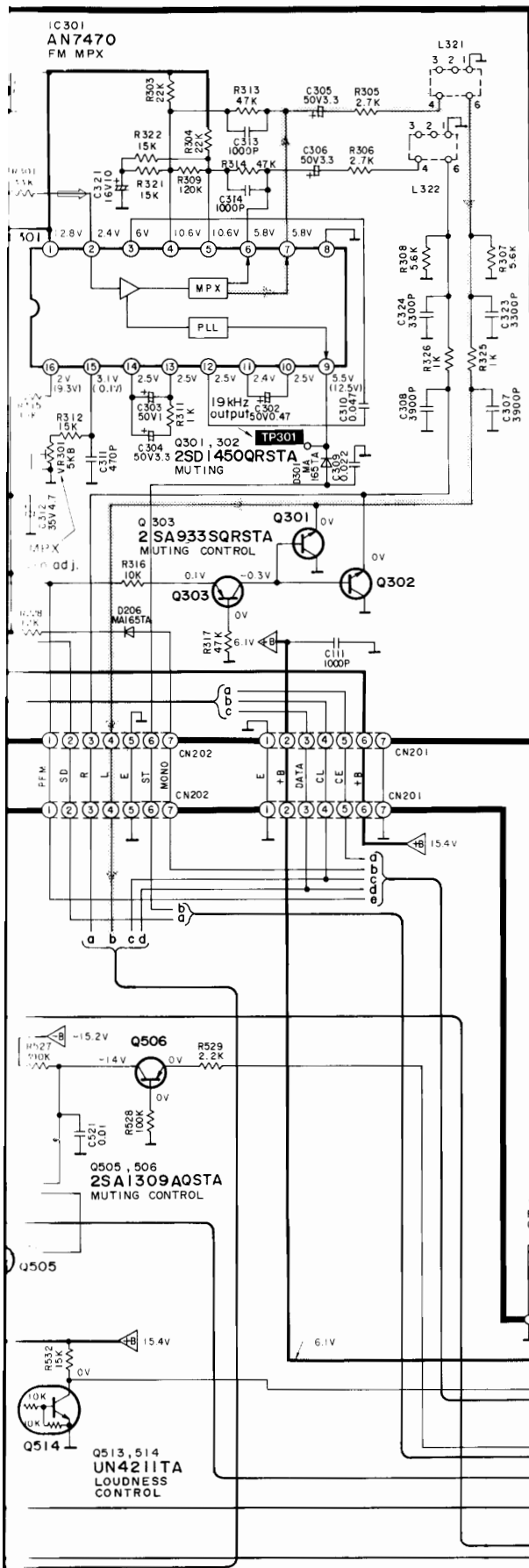

E REMOTE SENSOR CIRCUIT

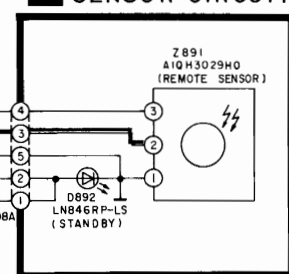

**G** VOLUME CIRCUIT

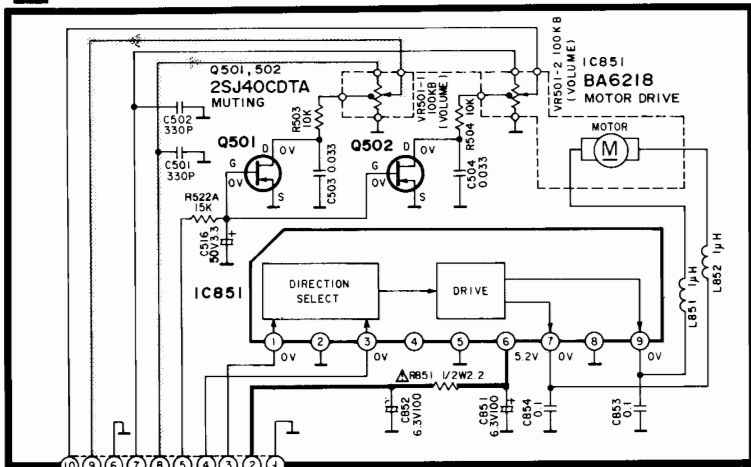

**F** TONE AMP CIRCUIT

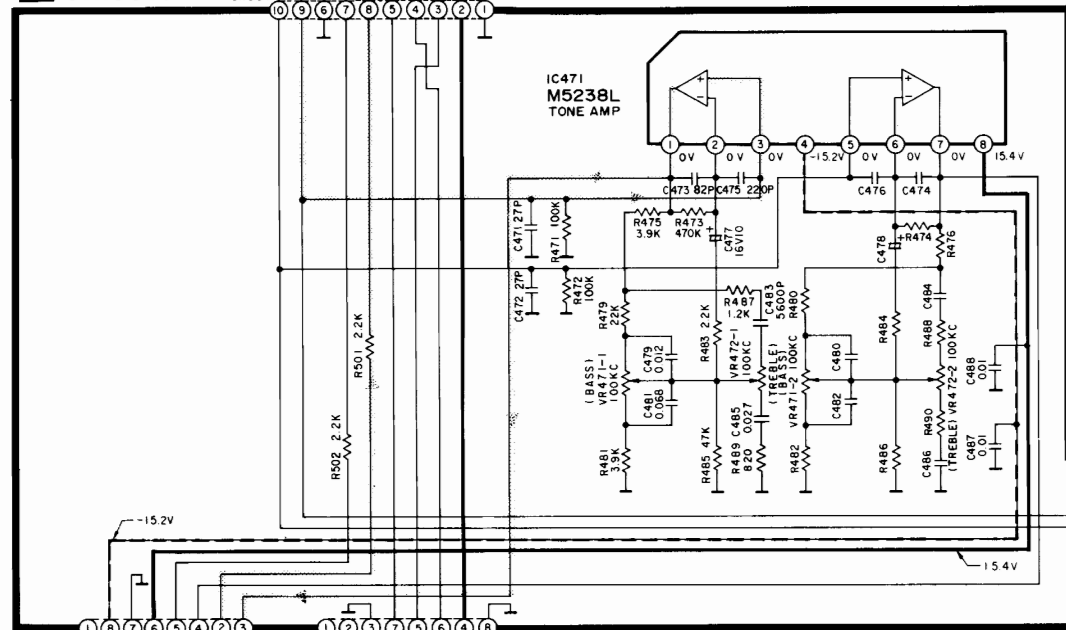

**I** BALANCE VR CIRCUIT

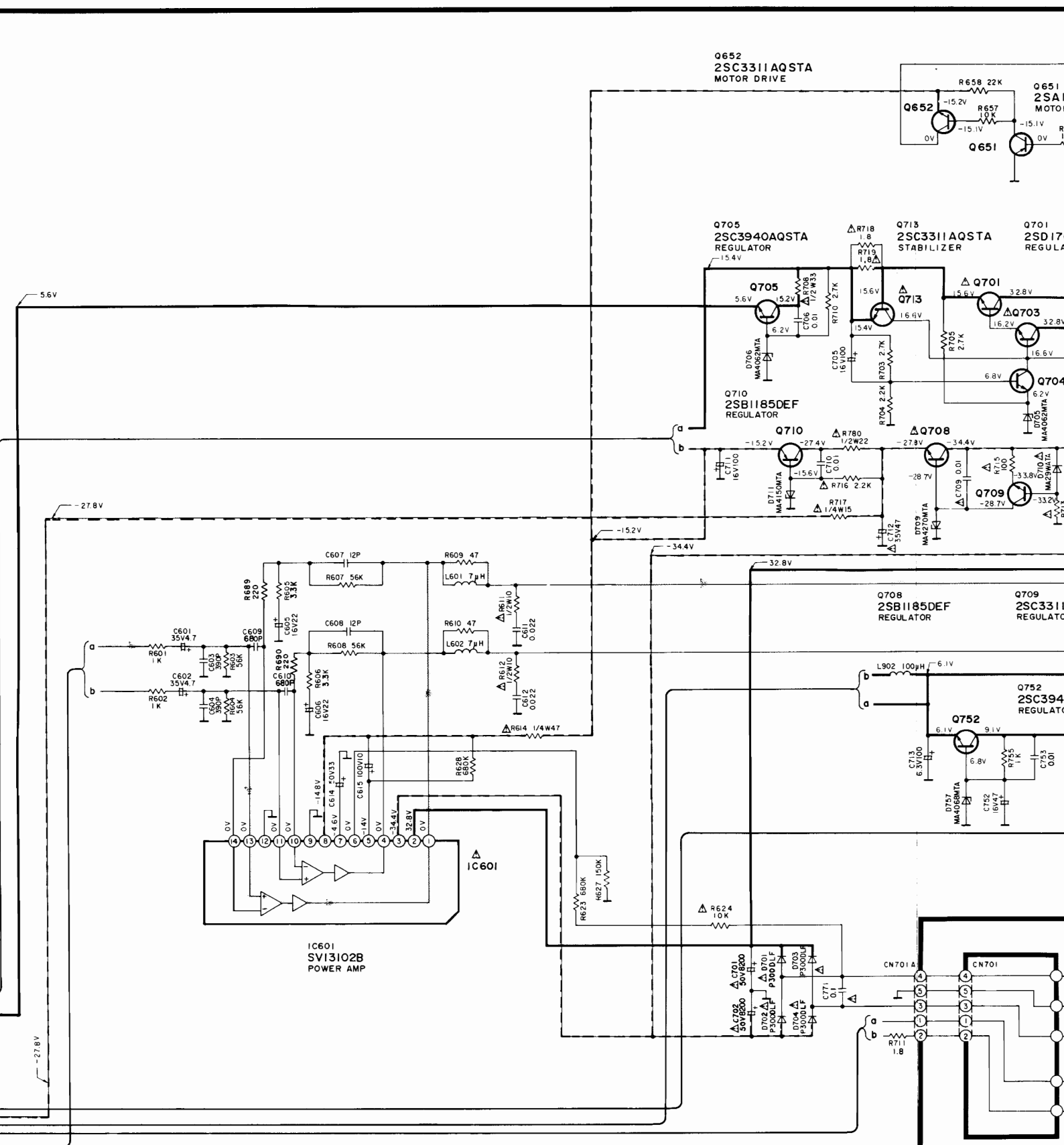
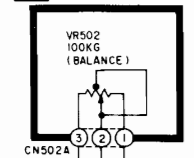



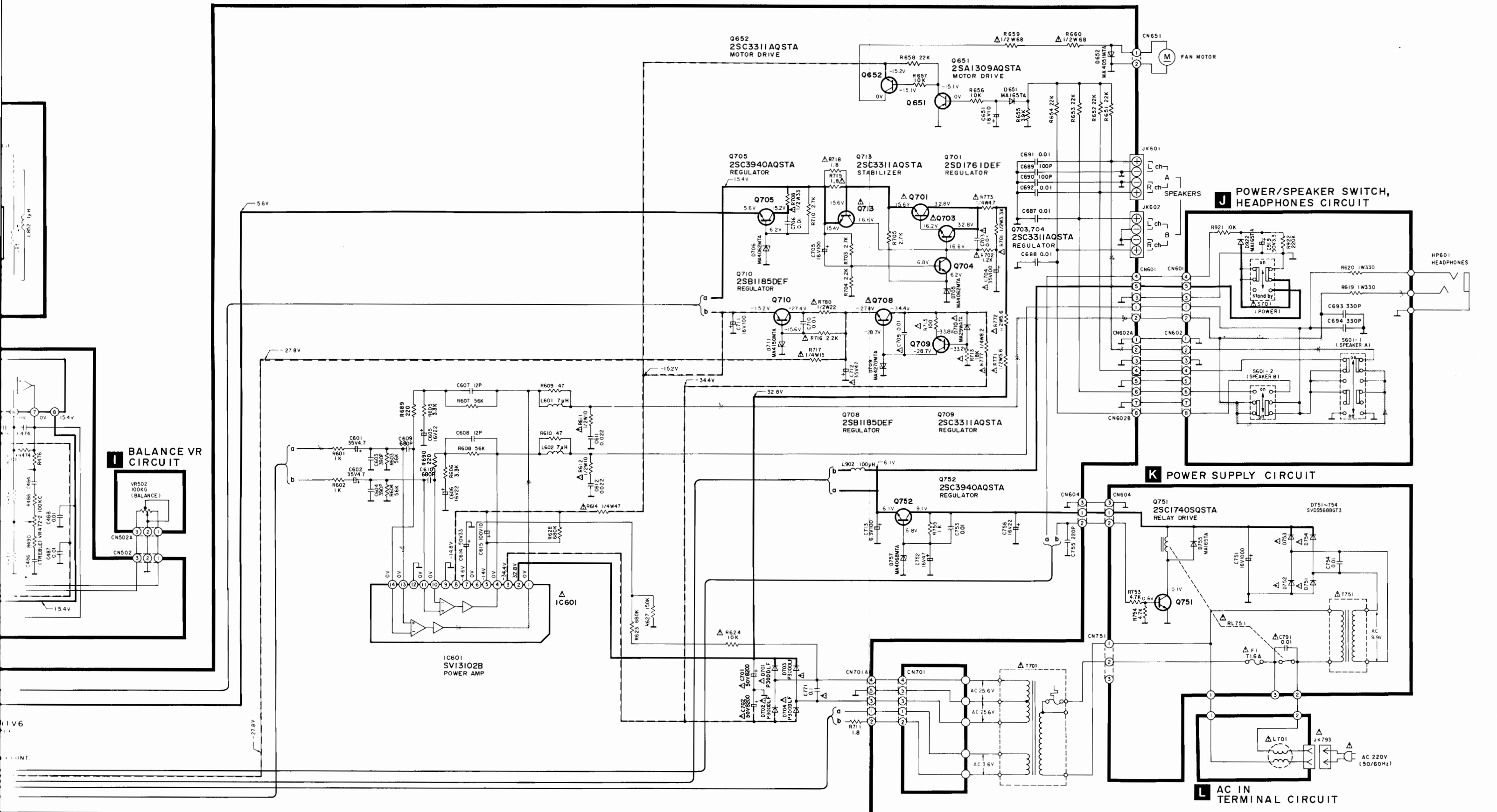

1 2 3 4 5 6 7 8 9 10

### PRINTED CIRCUIT BOARDS

#### A TUNER P.C.B.

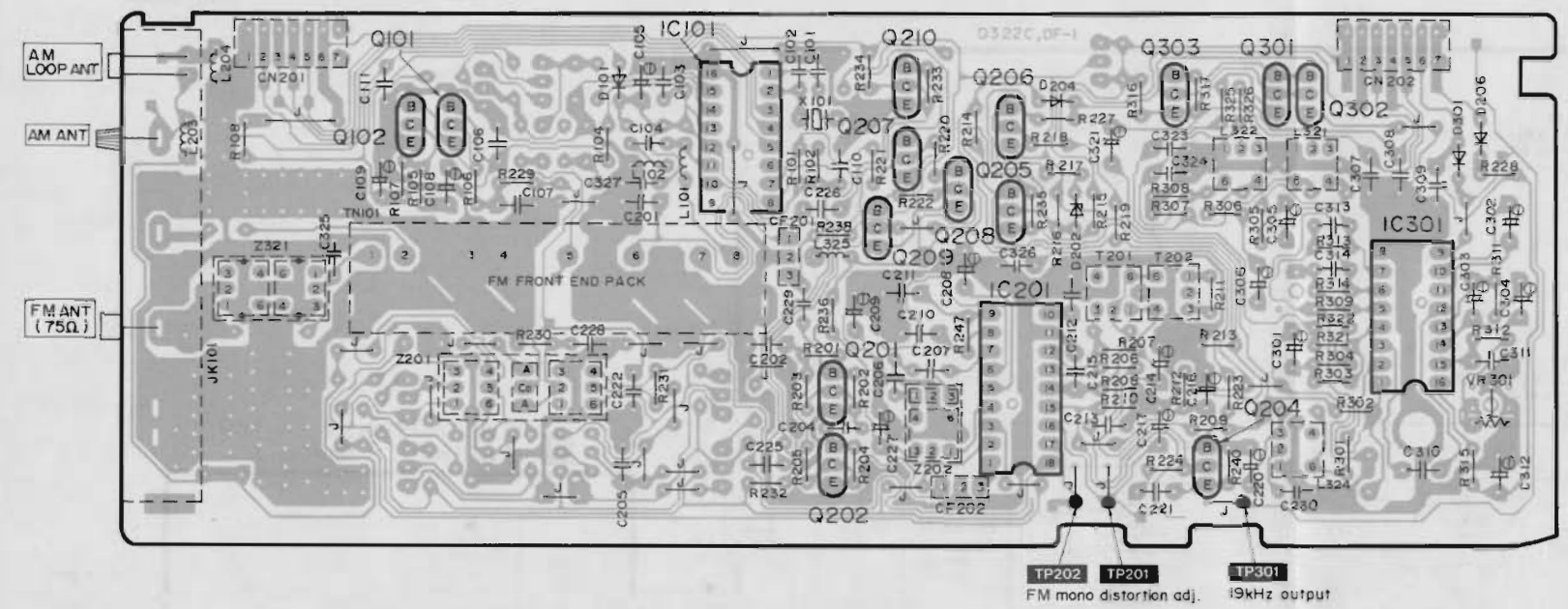

#### C FL DRIVE P.C.B.

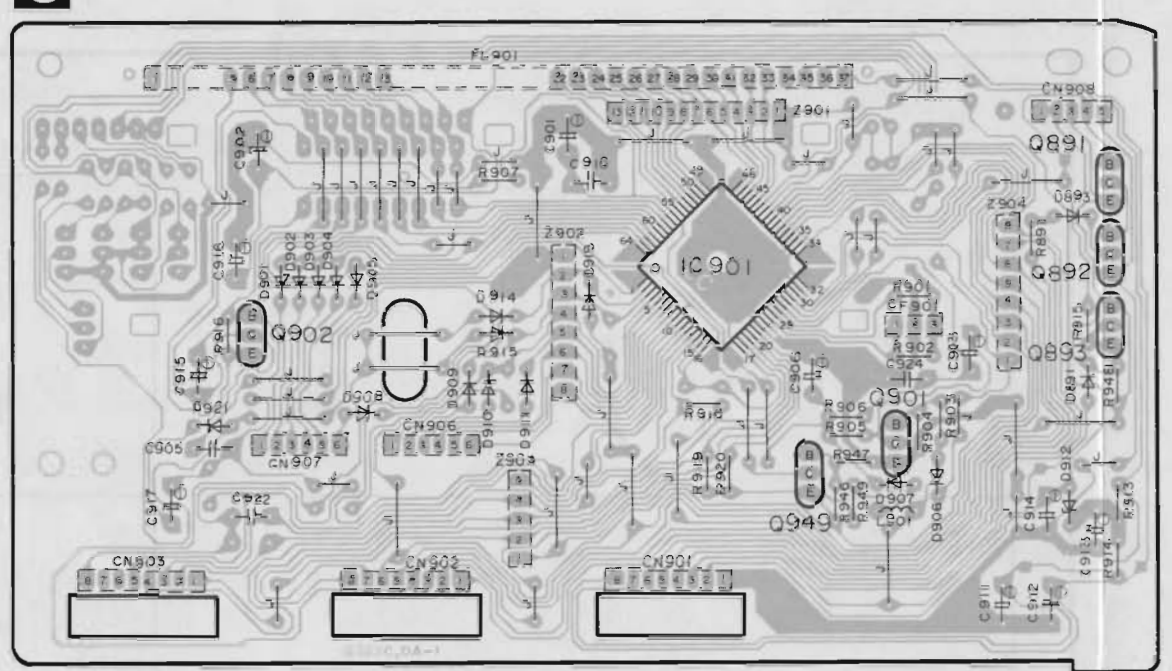

#### F TONE AMP P.C.B.

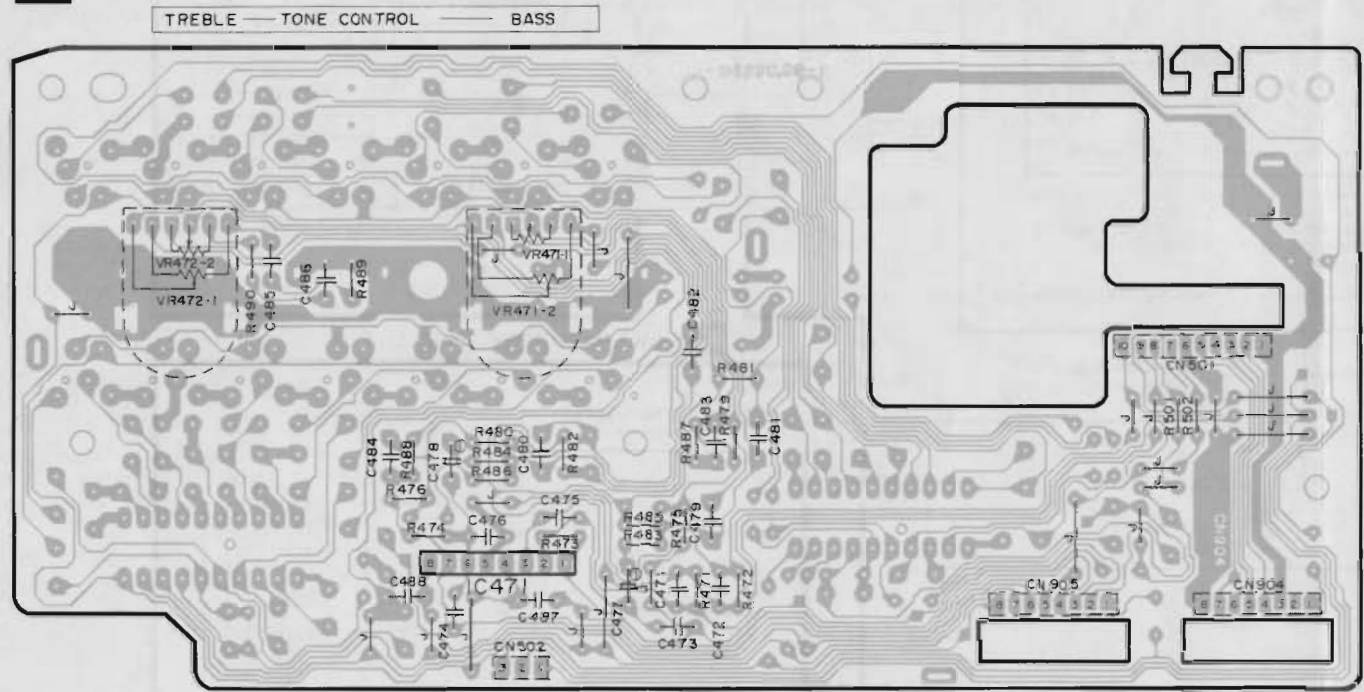

#### G VOLUME P.C.B.

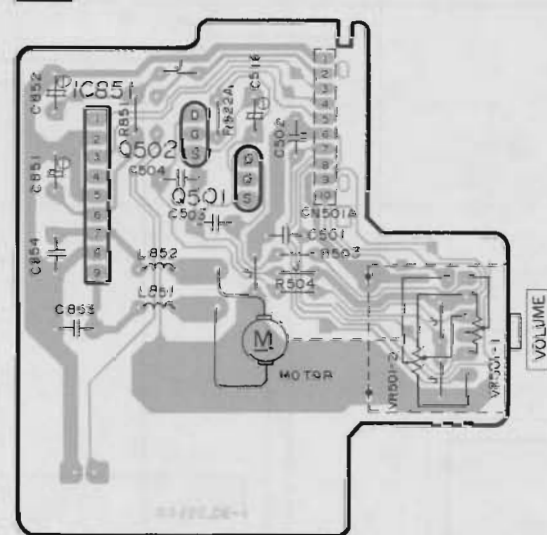

#### D OPERATION P.C.B.

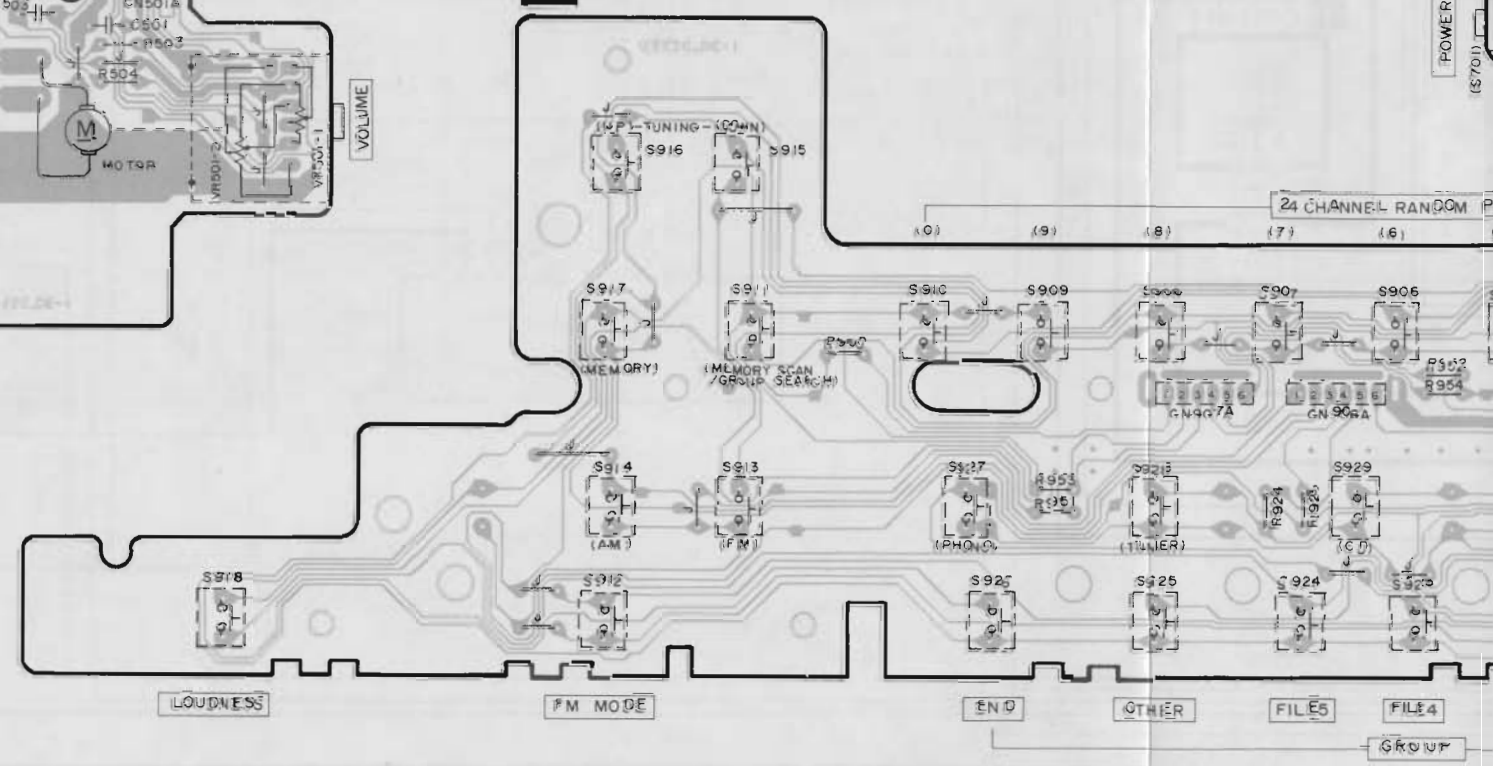

#### H VCR2 JACK P.C.B.

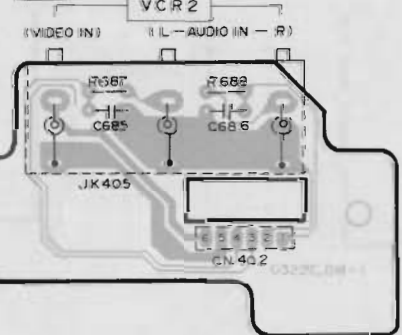

#### I BALANCE VR P.C.B.

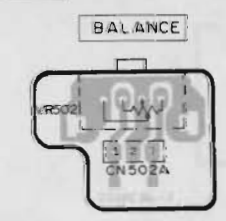









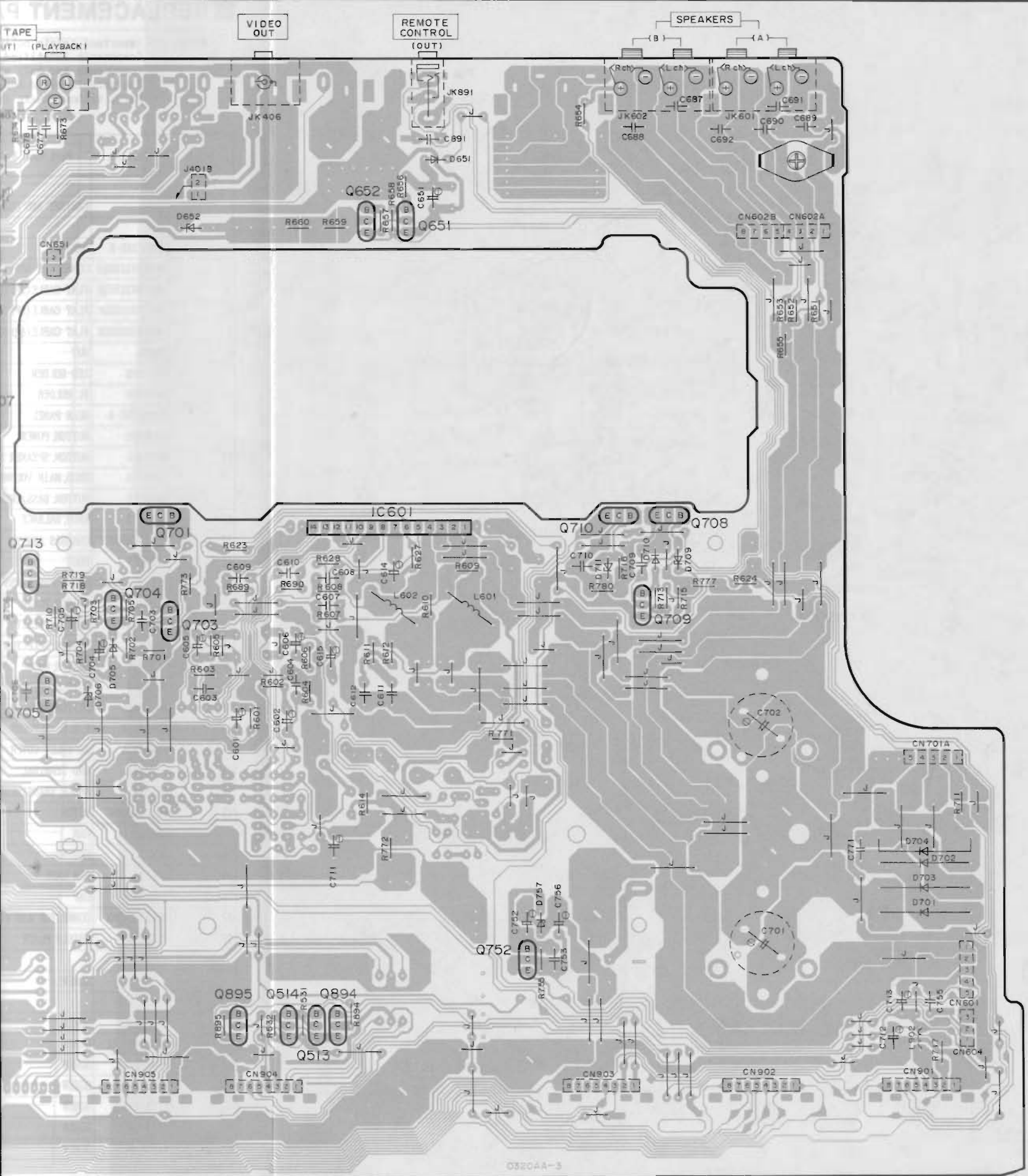

0320AA-3

### WIRING CONNECTION DIAGRAM

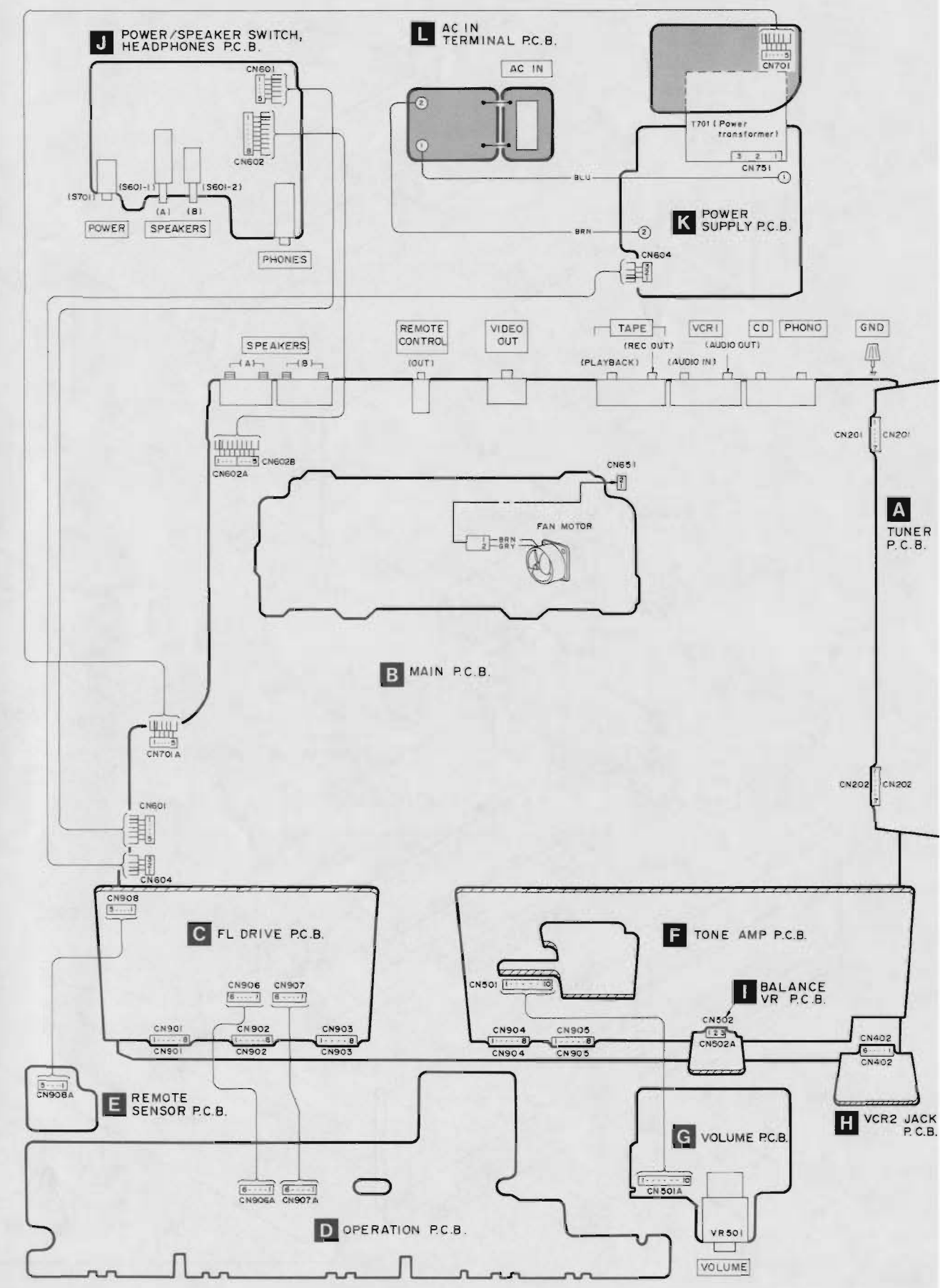



**EXPLODED VIEW**

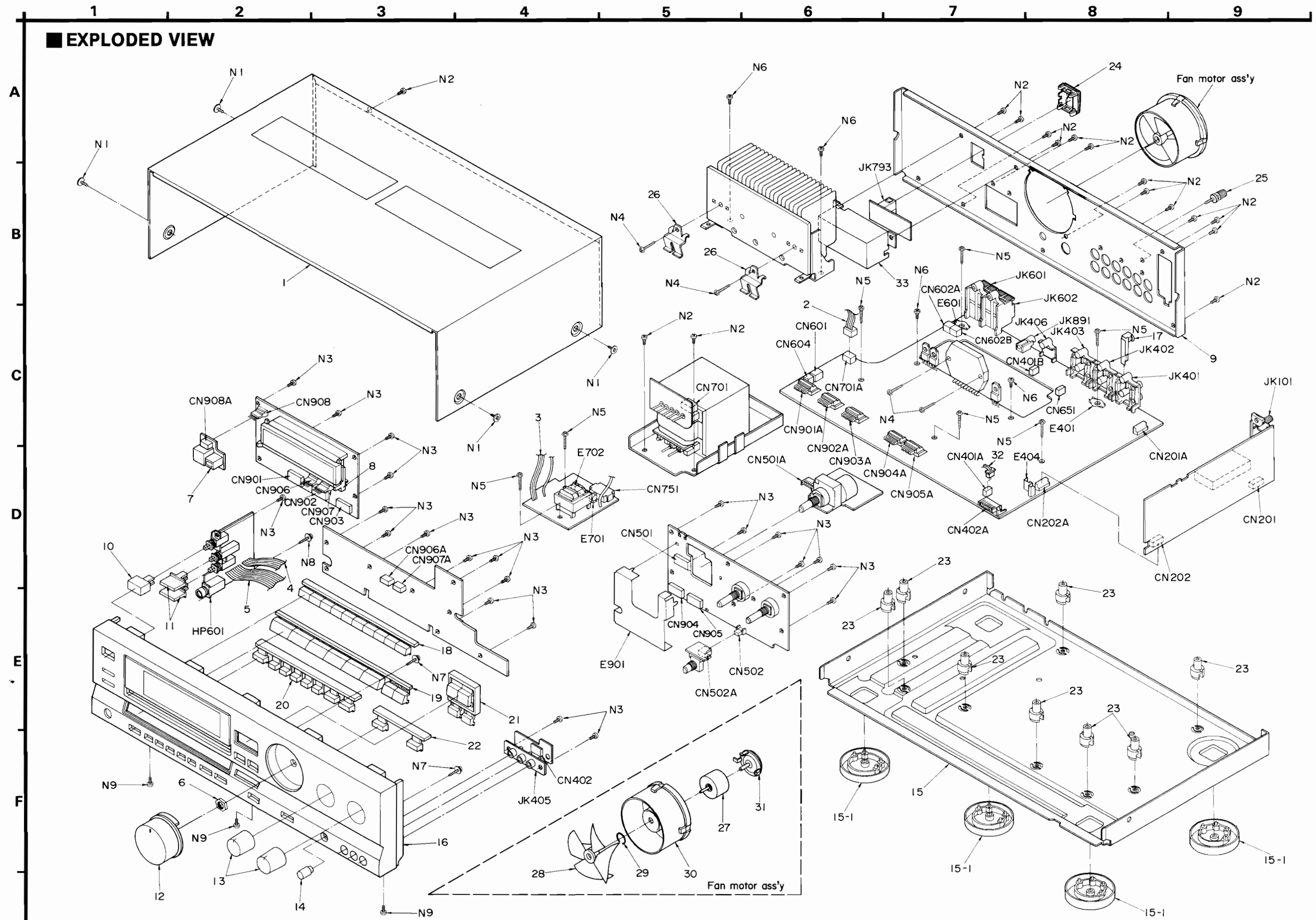

**REPLACEMENT**

Notes : \* Important safe components identified by components used in this manual. The parentheses indicate parts without drawings.

Ref. No.	Part No.	Part Name
		CABINET
1	RKMD036B-K	CABINET
2	RWJ1805140QQ	CONNECTOR
3	RWJ1803150QK	FLAT CAPACITOR
4	RWJ1805150QK	FLAT CAPACITOR
5	RWJ1808390QK	FLAT CAPACITOR
6	XNS7S	NUT
7	FMN0069	LED HOLDER
8	FMN0070	FL. HOLDER
9	RGR0079G-A	REAR PANEL
10	RGU0030	BUTTON
11	RGU0101	BUTTON
12	RGW0084	KNOB, MOUNTING
13	RGW0072	BUTTON
14	RGW0073	KNOB, BUSHING
15	RFKJAGX500PP	CHASSIS
15-1	RKA0009-1	FOOT
16	RFKGAGX200EG	FRONT PANEL
17	RSC0105	SHIELD
18	RGU0344A	BUTTON
19	RGU0394C	BUTTON
20	RGU0346	BUTTON
21	RGU0347	BUTTON
22	RGU0348A	BUTTON
23	SHE187-2	P. C. B.
24	SJS9231A	AC INDUCTOR
25	SNE2123	GND TERMINAL
26	SUS894-1	ANGLE, BRACKET
27	MDN-4RB4MRC	MOTOR
28	SHE222	FAN
29	SUS271	SPRING
30	SHE233	FAN CAPACITOR
31	SHE234	CAPACITOR
32	REL28H360XX	CONNECTOR
33	RSC0124	SHIELD
		SCREWS
N1	SNE2129-3	SCREW
N2	XTBS3+8JFZ1	SCREW
N3	XTBS26+8J	SCREW
N4	XTB3+16JFZ	SCREW
N5	XTB3+20JFZ	SCREW
N6	XTB3+8JFZ	SCREW
N7	XTWS3+8T	SCREW

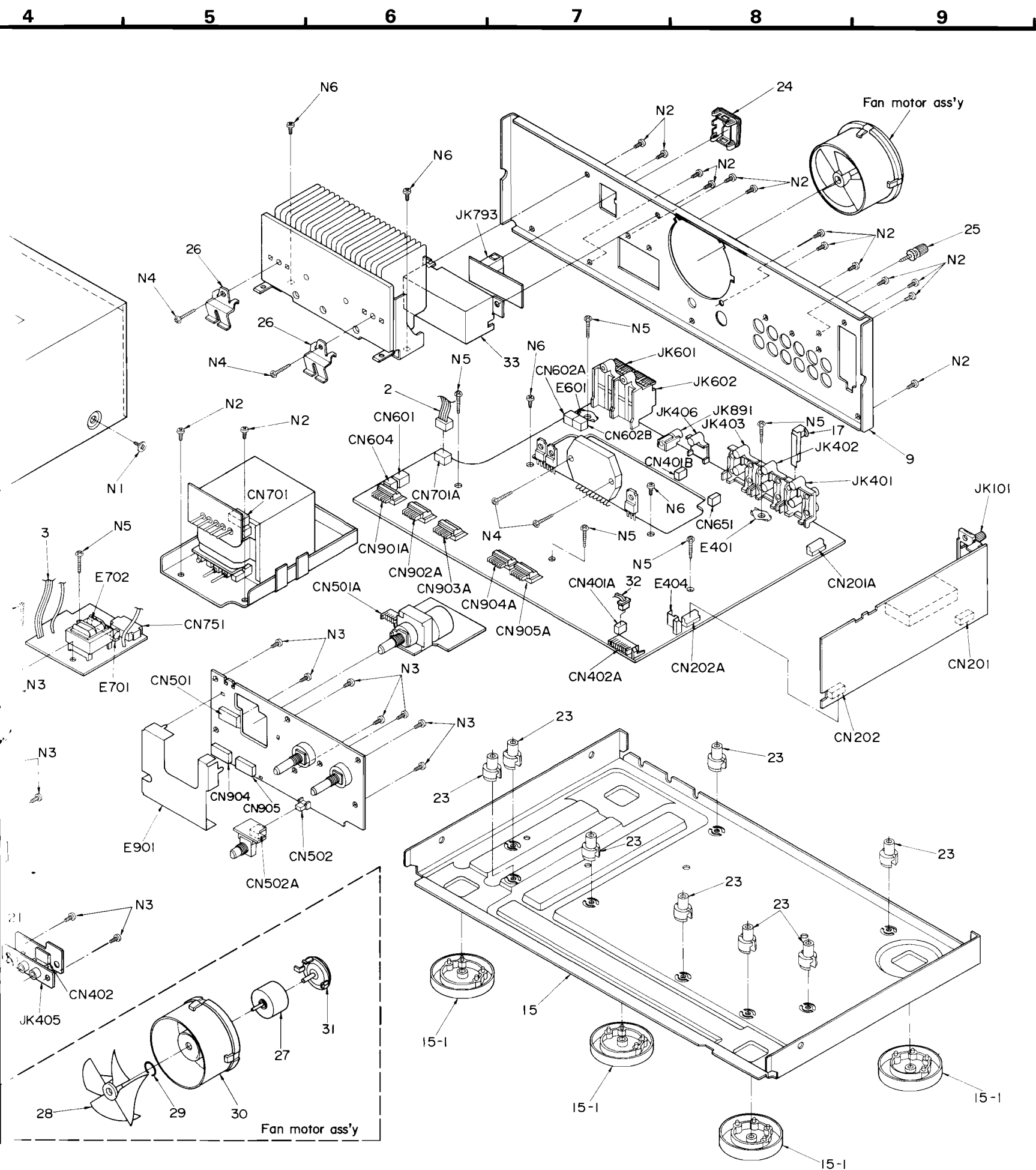

## REPLACEMENT PARTS LIST

Notes : \* Important safety notice:  
 Components identified by  $\Delta$  mark have special characteristics important for safety. When replacing any of these components use only manufacturer's specified parts.  
 \* The parenthesized indications in the Remarks column specify the areas. (Refer to the cover page for area.)  
 Parts without these indications can be used for all areas.

Ref. No.	Part No.	Part Name & Description	Remarks	Ref. No.	Part No.	Part Name & Description	Remarks
		CABINET AND CHASSIS		N8	XTWS3+10Q	SCREW	
				N9	XTB3+6JFZ	SCREW	
						PACKING MATERIAL	
1	RKMD036B-K	CABINET		P1	RPG0569	PACKING CASE	
2	RWJ1805140QQ	CONNECTOR ASS'Y (5P) (CN701)		P2	RPNO328A	PAD	
3	RWJ1803150QK	FLAT CABLE (3P) (CN604)		P3	RPNO328B	PAD	
4	RWJ1805150QK	FLAT CABLE (5P) (CN601)		P4	RPNO328C	PAD	
5	RWJ1808390QK	FLAT CABLE (8P) (CN602)		P5	RPNO328D	PAD	
6	XNS7S	NUT		P6	SPP723	PROTECTION BAG (UNIT)	
7	RMN0069	LED HOLDER		P7	SPSD152	ACCESSORIES BOX	
8	RMN0070	FL HOLDER		P8	SPB1061	PROTECTION BAG (F. B.)	
9	RGR0079G-A	REAR PANEL				ACCESSORIES	
10	RGU0030	BUTTON, POWER		A1	RQT0637-D	INSTRUCTION MANUAL	
11	RGU0101	BUTTON, SPEAKER SELECTOR		A2	SFDAC05E03	POWER CORD	$\Delta$
12	RGW0084	KNOB, MAIN VOLUME		A3	SPB1163T	AM LOOP ANTENNA	
13	RGW0072	BUTTON, BASS/TREBLE		A3-1	SMA233-1M	AM ANTENNA HOLDER	
14	RGW0073	KNOB, BALANCE		A3-2	XTN3+10AFZ	SCREWS	
15	REFKJAGX500PP	CHASSIS ASS'Y		A4	SSA270M	FM ANTENNA	
15-1	RKA0009-1	FOOT		A5	RQA0013	WARRANTY CARD	
16	REFKAGX200EG	FRONT PANEL ASS'Y		A6	RQC0169	SERVICENTER LIST	
17	RSCO105	SHIELD PLATE		A7	RAK-SA301E	REMOTE CONTROL TRANSMITTER	
18	RGU0344A	BUTTON, PRESET		A8	RKK0008	BATTERY COVER	
19	RGU0394C	BUTTON, SELECTOR					
20	RGU0346	BUTTON, GROUP					
21	RGU0347	BUTTON, UP-DOWN					
22	RGU0348A	BUTTON, MODE					
23	SHE187-2	P. C. B. SUPPORT					
24	SJS9231A	AC INLET COVER					
25	SNE2123	GND TERMINAL					
26	SUS894-1	ANGLE, TRANSISTOR					
27	MDN-4RB4MRC	MOTOR					
28	SHE222	FAN					
29	SJS271	SPRING					
30	SHE233	FAN CASE					
31	SHE234	CAP					
32	REL28H360XX	CONNECTOR ASS'Y (2P)					
33	RSCO124	SHIELD PLATE					
		SCREWS					
N1	SNE2129-3	SCREW					
N2	XTBS3+8JFZ1	SCREW					
N3	XTBS26+8J	SCREW					
N4	XTB3+16JFZ	SCREW					
N5	XTB3+20JFZ	SCREW					
N6	XTB3+8JFZ	SCREW					
N7	XTWS3+8T	SCREW					

## Notes : \* Important safety notice:

Components identified by  $\Delta$  mark have special characteristics important for safety. When replacing any of these components use only manufacturer's specified parts.

\* The parenthesized indications in the Remarks column specify the areas. (Refer to the cover page for area.) Parts without these indications can be used for all areas.

Ref. No.	Part No.	Part Name & Description	Remarks	Ref. No.	Part No.	Part Name & Description	Remarks
		INTEGRATED CIRCUIT(S)		Q901	ZSC1740SQ	TRANSISTOR	
				Q902	UN4215	TRANSISTOR	
				Q949	2SA933SQR	TRANSISTOR	
IC101	LM7001	I. C, PLL FREQ. SYNTHESIZER				DIODE(S)	
IC201	AN7273A	I. C, FM/AM [F AMP&MIXER		D101	MA165	DIODE	
IC301	SVIUPC1161C3	I. C, FM MPX		D202	MA4110MTA	DIODE	
IC401	TC9163N	I. C, INPUT SELECTOR		D204	MA165	DIODE	
IC402	M5238P-1	I. C, BUFFER AMP		D206	MA165	DIODE	
IC451	AN6558F	I. C, PHONO EQ. AMP		D301	MA165	DIODE	
IC471	M5238L	I. C, TONE CONTROL		D651	MA165	DIODE	
IC601	SVI3102B	I. C, POWER AMP	$\Delta$	D652	MA4051MTA	DIODE	
IC851	BA6218	I. C, MOTOR DRIVE		D701-704	P300DLF	DIODE	$\Delta$
IC901	LC6554H4097	I. C, MICROCOMPUTER		D705, 706	MA4062MTA	DIODE	
		TRANSISTOR(S)		D709	MA4270	DIODE	
				D710	MA29WA	DIODE	$\Delta$
Q101, 102	ZSC2785FE	TRANSISTOR		D711	MA4150M	DIODE	
Q201, 202	ZSC2787L	TRANSISTOR		D751-754	SVDS5688GT3	DIODE	$\Delta$
Q204, 205	ZSC1740SQ	TRANSISTOR		D755	MA165	DIODE	
Q206	2SA933SQR	TRANSISTOR		D757	MA4068M	DIODE	
Q207	ZSC1740SQ	TRANSISTOR		D891	MA165	DIODE	
Q208, 209	2SA933SQR	TRANSISTOR		D892	LN846RP	DIODE	
Q210	ZSC1740SQ	TRANSISTOR		D893	MA29WA	DIODE	
Q301, 302	ZSD1450QRSTA	TRANSISTOR		D901-906	MA165	DIODE	
Q303	2SA933SQR	TRANSISTOR		D907	1SS291TA	DIODE	
Q501, 502	ZSJ40CDTA	TRANSISTOR		D908-911	MA165	DIODE	
Q503, 504	ZSC3327-A	TRANSISTOR		D912	MA4051MTA	DIODE	
Q505, 506	2SA1309A-R	TRANSISTOR		D914, 915	MA165	DIODE	
Q507, 508	ZSC3327-A	TRANSISTOR		D919	MA165	DIODE	
Q513, 514	UN4211	TRANSISTOR		D921, 922	MA165	DIODE	
Q651	2SA1309A-R	TRANSISTOR				VARIABLE RESISTOR(S)	
Q652	ZSC3311A-Q	TRANSISTOR					
Q701	ZSD1761DEF	TRANSISTOR	$\Delta$	VR301	EVNDXAA00B53	V. R, MPX VCO ADJ.	
Q703	ZSC3311A-Q	TRANSISTOR	$\Delta$	VR471, 472	EW2XAF25C15	V. R, TONE CONTROL	
Q704	ZSC3311A-Q	TRANSISTOR		VR501	EUMNMF20B15	V. R, MAIN VOLUME	
Q705	ZSC3940AQSTA	TRANSISTOR		VR502	EVJ01CF01G15	V. R, BALANCE	
Q708	ZSB1185DEF	TRANSISTOR	$\Delta$			COMPONENT COMBINATION(S)	
Q709	ZSC3311A-Q	TRANSISTOR					
Q710	ZSB1185DEF	TRANSISTOR		Z201	RLA2Z001-T	COIL	
Q713	ZSC3311A-Q	TRANSISTOR	$\Delta$	Z202	SLI7Z101-T	COMPONENT COMBINATION	
Q751	ZSC1740SQ	TRANSISTOR		Z321	SLA4Z13-Z	COMPONENT COMBINATION	
Q752	ZSC3940AQSTA	TRANSISTOR		Z891	A1QH3029H0	REMOTE SENSOR	
Q891	UN4113TA	TRANSISTOR		Z901	EXFP12331MF	COMPONENT COMBINATION	
Q892	UN4214TA	TRANSISTOR		Z902	EXBF8E473J	COMPONENT COMBINATION	
Q893	2SA933SQR	TRANSISTOR					
Q894	UN4211	TRANSISTOR					
Q895	ZSB1240PRTV6	TRANSISTOR					

Ref. No.	Part No.	Part Name & Description	Remarks	Ref. No.	Part No.	Part Name & Description	Remarks
Z903	EXBF5E103J	COMPONENT COMBINATION		S903	EVQ21405R	SW, PRESET TUNING3	
Z904	EXBF8E103J	COMPONENT COMBINATION		S904	EVQ21405R	SW, PRESET TUNING4	
		COIL (S)		S905	EVQ21405R	SW, PRESET TUNING5	
L101	RLQZPR47KT-Y	COIL		S906	EVQ21405R	SW, PRESET TUNING6	
L102	RLQZP1R2KT-Y	COIL		S907	EVQ21405R	SW, PRESET TUNING7	
L203, 204	ELEPK1R0MA	COIL		S908	EVQ21405R	SW, PRESET TUNING8	
L321, 322	RLM2B003-K	COIL		S909	EVQ21405R	SW, PRESET TUNING9	
L324	SLM1B10-M	COIL		S910	EVQ21405R	SW, PRESET TUNING0	
L325	RLQZP1R2KT-Y	COIL		S911	EVQ21405R	SW, MEMORY SCAN	
L401	RLQZPR47KT-Y	COIL		S912	EVQ21405R	SW, FM MODE	
L601, 602	SLQY07G-40	COIL		S913	EVQ21405R	SW, FM	
L701	SLQZ650MH49	COIL	△	S914	EVQ21405R	SW, AM	
L851, 852	RLQZP1R0KT-Y	COIL		S915	EVQ21405R	SW, TUNING DOWN	
L901, 902	ELEPK101KA	COIL		S916	EVQ21405R	SW, TUNING UP	
		TRANSFORMER (S)		S917	EVQ21405R	SW, MEMORY	
T201	RLI4B002-Z	COIL		S918	EVQ21405R	SW, LOUDNESS	
T202	RLI4B003-Z	COIL		S919	EVQ21405R	SW, START	
T701	RTP1N5E005-V	POWER TRANSFORMER	△	S920	EVQ21405R	SW, FILE 1	
T751	RTP1I5E001-V	TRANSFORMER	△	S921	EVQ21405R	SW, FILE 2	
		FILTER(S)		S922	EVQ21405R	SW, FILE 3	
CF201	RLFKTF2M01LA	CERAMIC FILTER	(RED)	S923	EVQ21405R	SW, FILE 4	
CF201	RLFKTF2M01LB	CERAMIC FILTER	(BLUE)	S924	EVQ21405R	SW, FILE 5	
CF201	RLFKTF2M01LC	CERAMIC FILTER	(ORANGE)	S925	EVQ21405R	SW, OTHER	
CF202	RLFKTF2M01LA	CERAMIC FILTER	(RED)	S926	EVQ21405R	SW, END	
CF202	RLFKTF2M01LB	CERAMIC FILTER	(BLUE)	S927	EVQ21405R	SW, PHONO	
CF202	RLFKTF2M01LC	CERAMIC FILTER	(ORANGE)	S928	EVQ21405R	SW, TUNER	
CF901	EFOGC4004A4	CERAMIC FILTER		S929	EVQ21405R	SW, CD	
		OSCILLATOR(S)		S930	EVQ21405R	SW, VCR1	
X101	SVQ49U722-S	OSCILLATOR		S931	EVQ21405R	SW, VCR2	
		DISPLAY TUBE		S932	EVQ21405R	SW, TAPE MONITOR	
FL901	RSLO043-F	DISPLAY TUBE				CONNECTOR (S) & SOCKET (S)	
		FUSE (S)		CN201	RJT057W007	CONNECTOR (7P)	
F1	XBA2C16TB0	FUSE	△	CN201A	RJU057W007	SOCKET (7P)	
		SWITCH (ES)		CN202	RJT057W007	CONNECTOR (7P)	
S601	SSH2137	SW, SPEAKERS		CN202A	RJU057W007	SOCKET (7P)	
S701	SSH1238	SW, POWER	△	CN402	RJT003K006M1	CONNECTOR (6P)	
S901	EVQ21405R	SW, PRESET TUNING1		CN402A	RJU003K006M1	SOCKET (6P)	
S902	EVQ21405R	SW, PRESET TUNING2		CN501	RJT003K010M1	CONNECTOR (10P)	
				CN502	SJS50378JQ	SOCKET (3P)	
				CN601	RJS1A1705	CONNECTOR (5P)	
				CN604	RJS1A1703	CONNECTOR (3P)	
				CN651	SJT3213	CONNECTOR (2P)	
				CN701	RJS1A1705	CONNECTOR (5P)	
				CN751	SJS305-1	CONNECTOR (3P)	
				CN901	RJT003K008M1	CONNECTOR (8P)	
				CN901A	RJU003K008M1	SOCKET (8P)	
				CN902	RJT003K008M1	CONNECTOR (8P)	
				CN902A	RJU003K008M1	SOCKET (8P)	
				CN903	RJT003K008M1	CONNECTOR (8P)	
				CN903A	RJU003K008M1	SOCKET (8P)	

Ref. No.	Part No.	Part Name & Description	Remarks	Ref. No.	Part No.	Part Name & Description	Remarks
CN904	RJT003K008M1	CONNECTOR (8P)				JACK (S)	
CN904A	RJU003K008M1	SOCKET (8P)					
CN905	RJT003K008M1	CONNECTOR (8P)					
CN905A	RJU003K008M1	SOCKET (8P)		HP601	SJJ146B	JACK, HEADPHONE	
CN906, 907	SJT30648BB1	CONNECTOR (6P)		JK101	RJH4202	JACK, ANTENNA	
CN908	SJT30549BB1	CONNECTOR (5P)		JK401	SJF3069N	JACK, PHONO/CD	
CN401A	SJT3213	CONNECTOR (2P)		JK402	SJF3069N	JACK, VCR1	
CN501A	RJU003K010M1	SOCKET (10P)		JK403	SJF3069N	JACK, TAPE	
CN502A	SJT30345JQ	CONNECTOR (3P)		JK405	SJFK5-1	JACK, VCR2	
CN602A	RJS1A1704	SOCKET (4P)		JK406	SJFD7-4	JACK, VIDEO OUT	
CN701A	RJS1A1705	CONNECTOR (5P)		JK601	RJR0054A	JACK, SPEAKER	
CN906A	SJS50681BB	SOCKET (6P)		JK602	RJR0054A	JACK, SPEAKER	
CN907A	SJS50681BB	SOCKET (6P)		JK793	SJS9231-1B	JACK, AC INLET	△
CN908A	SJS50581BB	SOCKET (5P)		JK891	RJJ33TR01	JACK, REMOTE CONTROL OUT	
CN401B	SJT3213	CONNECTOR (2P)				RELAY (S)	
CN602B	RJS1A1704	SOCKET (4P)					
		SHIELD PART (S)		RL751	RSY0005-1C	RELAY	△
E401	SNE1004-1	GND PLATE				FRONT END PACK ASS'Y	
E404	SME103-6	P. C. B. HOLDER					
E601	SNE1004-1	GND PLATE		TN101	SNVFE337G01	FM FRONT END	
E701, 702	EYF52BC	FUSE HOLDER					
E901	RSC0111	SHIELD PLATE					

## PACKING

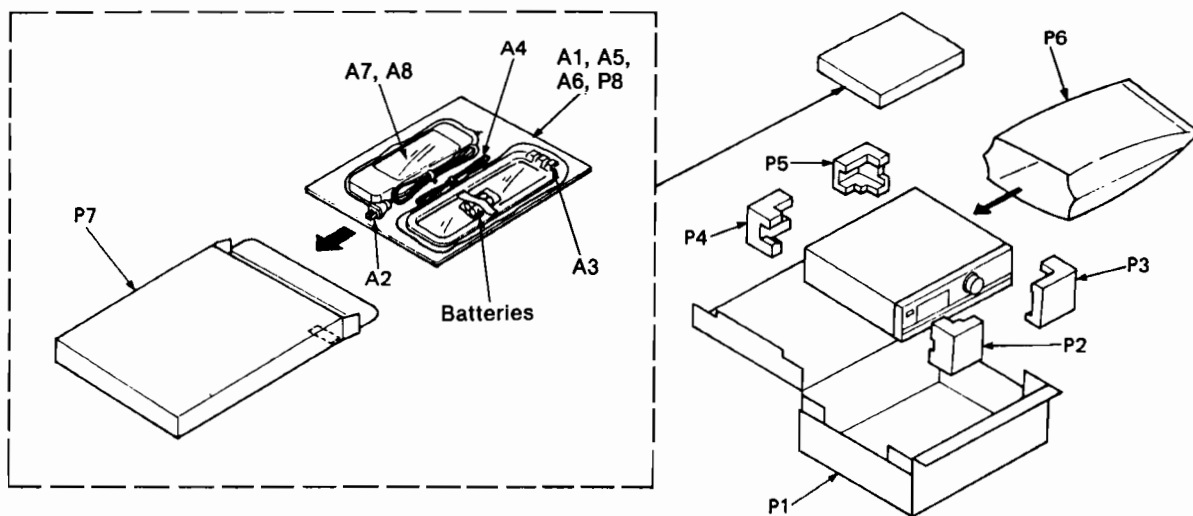

## RESISTORS &amp; CAPACITORS

Notes : \* Capacity value are in microfarads (uF) unless specified otherwise, P=Pico-farads (pF) F=Farads (F)  
 \* Resistance values are in ohms, unless specified otherwise, 1K=1,000(OHM) , 1M=1,000k(OHM)

Ref. No.	Part No.	Values & Remarks	Ref. No.	Part No.	Values & Remarks	Ref. No.	Part No.	Values & Remarks
		RESISTORS						
R101, 102	ERDS2TJ103	1/4W 10K	R305, 306	ERDS2TJ272T	1/4W 2.7K	R529	ERDS2TJ222	1/4W 2.2K
R104	ERDS2TJ102	1/4W 1K	R307, 308	ERDS2TJ562	1/4W 5.6K	R531, 532	ERDS2TJ153	1/4W 15K
R105	ERDS2TJ561	1/4W 560	R309	ERDS2TJ124T	1/4W 120K	R533, 534	ERDS2TJ331	1/4W 330
R106	ERDS2TJ562	1/4W 5.6K	R311	ERDS2TJ102	1/4W 1K	R601, 602	ERDS2TJ102	1/4W 1K
R107	ERDS2TJ103	1/4W 10K	R312	ERDS2TJ153	1/4W 15K	R603, 604	ERDS2TJ563	1/4W 56K
R108	ERDS2TJ151	1/4W 150	R313, 314	ERDS2TJ473	1/4W 47K	R605, 606	ERDS2TJ332	1/4W 3.3K
R201	ERDS2TJ822	1/4W 8.2K	R315, 316	ERDS2TJ103	1/4W 10K	R607, 608	ERDS2TJ563	1/4W 56K
R202	ERDS2TJ474	1/4W 470K	R317	ERDS2TJ473	1/4W 47K	R609, 610	ERDS2TJ470	1/4W 47
R203	ERDS2TJ331	1/4W 330	R321, 322	ERDS2TJ153	1/4W 15K	R611, 612	ERDS1FVJ100T	1/2W 10 Δ
R204	ERDS2TJ824	1/4W 820K	R325, 326	ERDS2TJ102	1/4W 1K	R614	ERD25FJ470	1/4W 47 Δ
R205	ERDS2TJ271	1/4W 270	R401, 402	ERDS2TJ332	1/4W 3.3K	R619, 620	ERG1ANJ331	1W 330
R206	ERDS2TJ561	1/4W 560	R403, 404	ERDS2TJ822	1/4W 8.2K	R623	ERDS2TJ684	1/4W 680K
R207	ERDS2TJ822	1/4W 8.2K	R405, 406	ERDS2TJ470	1/4W 47	R624	ERDS2TJ103	1/4W 10K Δ
R208	ERDS2TJ102	1/4W 1K	R407, 408	ERDS2TJ473	1/4W 47K	R627	ERDS2TJ154	1/4W 150K
R209	ERDS2TJ471	1/4W 470	R411, 412	ERDS2TJ104	1/4W 100K	R628	ERDS2TJ684	1/4W 680K
R210	ERDS2TJ332	1/4W 3.3K	R413, 414	ERDS2TJ102	1/4W 1K	R651-654	ERDS2TJ223	1/4W 22K
R211	ERDS2TJ222	1/4W 2.2K	R417, 418	ERDS2TJ104	1/4W 100K	R655	ERDS2TJ392T	1/4W 3.9K
R212	ERDS2TJ153	1/4W 15K	R421	ERDS2TJ332	1/4W 3.3K	R656, 657	ERDS2TJ103	1/4W 10K
R213	ERDS2TJ104	1/4W 100K	R451, 452	ERDS2TJ391	1/4W 390	R658	ERDS2TJ223	1/4W 22K
R214	ERDS2TJ824	1/4W 820K	R453, 454	ERDS2TJ224T	1/4W 220K	R659, 660	ERDS1FVJ680T	1/2W 68 Δ
R215	ERDS2TJ822	1/4W 8.2K	R455, 456	ERDS2TJ563	1/4W 56K	R671, 672	ERDS2TJ471	1/4W 470
R216	ERDS2TJ563	1/4W 56K	R457, 458	ERDS2TJ271	1/4W 270	R673, 674	ERDS2TJ222	1/4W 2.2K
R217	ERDS2TJ223	1/4W 22K	R459, 460	ERDS2TJ680T	1/4W 68	R675, 676	ERDS2TJ102	1/4W 1K
R218	ERDS2TJ123	1/4W 12K	R461, 462	ERDS2TJ184T	1/4W 180K	R681, 682	ERDS2TJ222	1/4W 2.2K
R219	ERDS2TJ562	1/4W 5.6K	R463, 464	ERDS2TJ123	1/4W 12K	R683, 684	ERDS2TJ102	1/4W 1K
R220	ERDS2TJ103	1/4W 10K	R465, 466	ERDS2TJ563	1/4W 56K	R687, 688	ERDS2TJ102	1/4W 1K
R221	ERDS2TJ104	1/4W 100K	R467, 468	ERDS2TJ102	1/4W 1K	R689, 690	ERDS2TJ221	1/4W 220
R222	ERDS2TJ473	1/4W 47K	R471, 472	ERDS2TJ104	1/4W 100K	R701	ERDS1FVJ332T	1/2W 3.3K Δ
R223	ERDS2TJ154	1/4W 150K	R473, 474	ERDS2TJ474	1/4W 470K	R702	ERDS2TJ122	1/4W 1.2K Δ
R224	ERDS2TJ223	1/4W 22K	R475, 476	ERDS2TJ392T	1/4W 3.9K	R703	ERDS2TJ272T	1/4W 2.7K
R227	ERDS2TJ104	1/4W 100K	R479, 480	ERDS2TJ223	1/4W 22K	R704	ERDS2TJ222	1/4W 2.2K
R228	ERDS2TJ123	1/4W 12K	R481, 482	ERDS2TJ392T	1/4W 3.9K	R705	ERDS2TJ272T	1/4W 2.7K
R229	ERDS2TJ102	1/4W 1K	R483, 484	ERDS2TJ222	1/4W 2.2K	R708	ERDS1FJ330	1/2W 33 Δ
R230	ERDS2TJ104	1/4W 100K	R485, 486	ERDS2TJ473	1/4W 47K	R710	ERDS2TJ272T	1/4W 2.7K
R231	ERDS2TJ471	1/4W 470	R487, 488	ERDS2TJ122	1/4W 1.2K	R711	ERDS2TJ1R8T	1/4W 1.8
R232	ERDS2TJ122	1/4W 1.2K	R489, 490	ERDS2TJ821	1/4W 820	R713	ERDS2TJ183T	1/4W 18K Δ
R233	ERDS2TJ684	1/4W 680K	R501, 502	ERDS2TJ222	1/4W 2.2K	R715	ERDS2TJ101	1/4W 100 Δ
R234	ERDS2TJ103	1/4W 10K	R503, 504	ERDS2TJ103	1/4W 10K	R716	ERDS2TJ222	1/4W 2.2K Δ
R235	ERDS2TJ471	1/4W 470	R513, 514	ERDS2TJ393	1/4W 39K	R717	ERD25FVJ150T	1/4W 15 Δ
R236	ERDS2TJ183T	1/4W 18K	R515, 516	ERDS2TJ222	1/4W 2.2K	R718, 719	ERDS2TJ1R8T	1/4W 1.8 Δ
R238	ERDS2TJ471	1/4W 470	R517, 518	ERDS2TJ102	1/4W 1K	R753, 754	ERDS2TJ472	1/4W 4.7K
R240	ERDS2TJ152	1/4W 1.5K	R520	ERDS2TJ394	1/4W 390K	R755	ERDS2TJ102	1/4W 1K
R247	ERDS2TJ103	1/4W 10K	R521	ERDS2TJ104	1/4W 100K	R771, 772	ERDS1FVJ5R6T	1/2W 5.6 Δ
R301	ERDS2TJ333	1/4W 33K	R522	ERDS2TJ103	1/4W 10K	R773	ERD25FVJ4R7T	1/4W 4.7 Δ
R302	ERDS2TJ151	1/4W 150	R522A	ERDS2TJ153	1/4W 15K	R777	ERD25FVJ8R2T	1/4W 8.2 Δ
R303, 304	ERDS2TJ223	1/4W 22K	R523, 524	ERDS2TJ221	1/4W 220	R780	ERDS1FVJ220T	1/2W 22 Δ
			R525, 526	ERDS2TJ102	1/4W 1K	R851	ERDS1FVJ2R2T	1/2W 2.2 Δ
			R527	ERDS2TJ394	1/4W 390K	R891	ERDS2TJ102	1/4W 1K
			R528	ERDS2TJ104	1/4W 100K	R894	ERDS2TJ102	1/4W 1K



Ref. No.	Part No.	Values & Remarks	Ref. No.	Part No.	Values & Remarks	Ref. No.	Part No.	Values & Remarks
R895	ERDS2TJ103	1/4W 10K	C228	ECBT1H100JC5	50V 10P	C607, 608	ECCRH120K5	50V 12P
R901	ERDS2TJ152	1/4W 1.5K	C229	ECBT1H102KB5	50V 1000P	C609, 610	ECKD1H681KB	50V 680P
R902	ERDS2TJ105T	1/4W 1M	C230	ECBT1H471KB5	50V 470P	C611, 612	ECKT1H223ZF	50V 0.022U
R903	ERDS2TJ563	1/4W 56K	C301	ECEA1CU101	16V 100U	C614	ECEA1HJ330	50V 33U
R904	ERDS2TJ123	1/4W 12K	C302	ECEA1HKR47	50V 0.47U	C615	ECEA2AJ100	100V 10U
R905	ERDS2TJ103	1/4W 10K	C303	ECEA1HK010B	50V 1U	C651	ECEA1CPS100	16V 10U
R906	ERDS2TJ334	1/4W 330K	C304-306	ECEA1HK3R3	50V 3.3U	C671, 672	ECBT1H180JC5	50V 18P
R907	ERDS2TJ681	1/4W 680	C307, 308	ECFR1E392KR	25V 3900P	C673, 674	ECBT1H221KB5	50V 220P
R910	ERDS2TJ122	1/4W 1.2K	C309	ECKT1H223ZF	50V 0.022U	C675, 676	ECBT1H101KB5	50V 100P
R913, 914	ERDS2TJ101	1/4W 100	C310	ECFR1E473KR	25V 0.047U	C677, 678	ECBT1H331KB5	50V 330P
R915	ERDS2TJ331	1/4W 330	C311	ECQP1471JZ	50V 470P	C679, 680	ECBT1H101KB5	50V 100P
R916	ERDS2TJ104	1/4W 100K	C312	ECEA1VK4R7	35V 4.7U	C685, 686	ECBT1H101KB5	50V 100P
R919, 920	ERDS2TJ122	1/4W 1.2K	C313, 314	ECBT1H102KB5	50V 1000P	C687, 688	ECKRH1H03ZF5	50V 0.01U
R921	ERDS2TJ103	1/4W 10K	C321	ECEA1CK100B	16V 10U	C689, 690	ECKT1H101KB	50V 100P
R922	ERDS2TJ224T	1/4W 220K	C323, 324	ECFR1E332KR	25V 3300P	C691, 692	ECKRH1H03ZF5	50V 0.01U
R923-925	ERDS2TJ331	1/4W 330	C325	ECBT1H330J5	50V 33P	C693, 694	ECKRH1H331KB5	50V 330P
R946	ERDS2TJ222	1/4W 2.2K	C326	ECKRH1H03ZF5	50V 0.01U	C695, 696	ECBT1H331KB5	50V 330P
R947	ERDS2TJ103	1/4W 10K	C327	ECBT1H102KB5	50V 1000P	C697, 698	ECBT1H101KB5	50V 100P
R948	ERDS2TJ221	1/4W 220	C401, 402	ECKRH1H03ZF5	50V 0.01U	C701, 702	ECES1HV822U2	50V 8200U Δ
R949	ERDS2TJ472	1/4W 4.7K	C407, 408	ECBT1H101KB5	50V 100P	C703	ECKRH1H03ZF5	50V 0.01U Δ
R950-954	ERDS2TJ562	1/4W 5.6K	C409, 410	ECKRH1H03ZF5	50V 0.01U	C704	ECEA1VJ101B	35V 100U Δ
			C411, 412	ECEA1VPS4R7	35V 4.7U	C705	ECEA1CU101	16V 100U
		CAPACITORS	C415, 416	ECKRH1H03ZF5	50V 0.01U	C706	ECKRH1H03ZF5	50V 0.01U
			C417	ECBT1H121KB5	50V 120P	C709	ECKRH1H03ZF5	50V 0.01U Δ
C101, 102	ECBT1H150JC5	50V 15P	C419	ECEA0JU101B	6.3V 100U	C710	ECKRH1H03ZF5	50V 0.01U
C103	ECBT1H102KB5	50V 1000P	C421, 422	ECEA1CPS220	16V 22U	C711	ECEA1CU101	16V 100U
C104	ECBT1H181KB5	50V 180P	C425	ECBT1H101KB5	50V 100P	C712	ECEA1VJ470	35V 47U Δ
C105	ECEA0JU221	6.3V 220U	C451, 452	ECEA1VPS4R7	35V 4.7U	C713	ECEA0JU101B	6.3V 100U
C106	ECKRH1H03ZF5	50V 0.01U	C453, 454	ECBT1H101KB5	50V 100P	C751	ECEA1CU102	16V 1000U
C107	ECKT1H223ZF	50V 0.022U	C455, 456	ECBT1H102KB5	50V 1000P	C752	ECEA1CU470	16V 47U
C108	ECEA25M4R7R	25V 4.7U	C457, 458	ECFR1E223KR	25V 0.022U	C753, 754	ECKRH1H03ZF5	50V 0.01U
C109	ECEA1CU330	16V 33U	C459, 460	ECFR1E682KR	25V 6800P	C755	ECBT1H221KB5	50V 220P
C110, 111	ECBT1H102KB5	50V 1000P	C461, 462	ECEA1VPS4R7	35V 4.7U	C756	ECEA1CPS220	16V 22U
C201, 202	ECKRH1H03ZF5	50V 0.01U	C463, 464	ECEA0JPS330	6.3V 33U	C771	ECQE1104KF3	100V 0.1U Δ
C204	ECBT1H470J5	50V 47P	C471, 472	ECBT1H270J5	50V 27P	C791	ECKWKC103PF2	400V 0.01U Δ
C205	ECKT1H223ZF	50V 0.022U	C473, 474	ECBT1H820KB5	50V 82P	C851, 852	ECEA0JU101B	6.3V 100U
C206	ECBT1H150JC5	50V 15P	C475, 476	ECBT1H221KB5	50V 220P	C853, 854	ECFR1E104KR	25V 0.1U
C207	ECBT1C103MS5	16V 0.01U	C477, 478	ECEA1CK100B	16V 10U	C891	ECFR1E392KR	25V 3900P
C208	ECEA0JU101B	6.3V 100U	C479, 480	ECFR1E123KR	25V 0.012U	C901, 902	ECEA0JU102	6.3V 1000U
C209	ECEA1CK100B	16V 10U	C481, 482	ECFR1E683KR	25V 0.068U	C903	ECEA1HK010B	50V 1U
C210-212	ECKT1H223ZF	50V 0.022U	C483, 484	ECFR1E562KR	25V 5600P	C905	ECKRH1H331KB5	50V 330P
C213	ECBT1H101KB5	50V 100P	C485, 486	ECFR1E273KR	25V 0.027U	C906	ECEA0JU471	6.3V 470U
C214	ECEA1CK100B	16V 10U	C487, 488	ECKRH1H03ZF5	50V 0.01U	C910	ECKRH1H03ZF5	50V 0.01U
C215	ECKRH1H03ZF5	50V 0.01U	C501, 502	ECBT1H331KB5	50V 330P	C911-913	ECEA1HK3R3	50V 3.3U
C216	ECEA1CK100B	16V 10U	C503, 504	ECFR1E333KR	25V 0.033U	C914	ECEA1VK100B	35V 10U
C217	ECEA1HK2R2B	50V 2.2U	C513, 514	ECEA1VPS4R7	35V 4.7U	C915	ECEA1VJ101B	35V 100U
C220	ECEA1CK100B	16V 10U	C516	ECEA1HK3R3	50V 3.3U	C916	ECEA0JU102	6.3V 1000U
C221	ECFR1E183KR	25V 0.018U	C520, 521	ECKRH1H03ZF5	50V 0.01U	C917	ECEA0JU101B	6.3V 100U
C222	ECQM1H473JZ	50V 0.047U	C523, 524	ECBT1H330J5	50V 33P	C919	ECEA1HK3R3	50V 3.3U
C225	ECBT1H180JC5	50V 18P	C601, 602	ECEA1VPS4R7	35V 4.7U	C922	ECKRH1H331KB5	50V 330P
C226	ECKRH1H03ZF5	50V 0.01U	C603, 604	ECKRH1H391KB5	50V 390P	C924	ECKRH1H03ZF5	50V 0.01U
C227	ECEA1CK100B	16V 10U	C605, 606	ECEA1CPS220	16V 22U			