

# Service Manual

AV Control Stereo Receiver

Receiver

SA-GX470

Colour

(K) ... Black Type

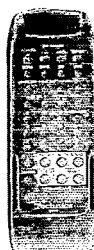

## Areas

Suffix for Model No.	Area	Colour
(E)	Europe.	(K)
(EB)	Great Britain.	
(EG)	Germany and Italy.	
(G)	Asia, Latin America, Middle Near East and Africa.	
(GN)	Oceania.	

## SPECIFICATIONS (DIN 45 500)

## ■ AMPLIFIER SECTION

<b>Power output (at 240 V)</b>	
DIN 1 kHz (T.H.D. 1%)	
[For (E, EB, EG) areas.]	2 × 80 W (4 Ω)
[For (G, GN) areas.]	2 × 100 W (8 Ω)
<b>20 Hz–20 kHz continuous power output</b>	
both channels driven	
[For (E, EB, EG) areas.]	2 × 50 W (8 Ω)
[For (G, GN) areas.]	2 × 80 W (8 Ω)
<b>Total harmonic distortion</b>	
rated power at 20 Hz–20 kHz	0.05% (8 Ω)
half power at 1 kHz	0.03% (8 Ω)
<b>Power output at the Dolby Pro Logic operation</b>	
DIN 1 kHz (T.H.D. 1%)	
<b>Front [For (E, EB, EG) areas.]</b>	2 × 50 W (4 Ω)
[For (G, GN) areas.]	2 × 40 W (8 Ω)
<b>Center [For (E, EB, EG) areas.]</b>	50 W (4 Ω)
[For (G, GN) areas.]	40 W (8 Ω)
<b>Rear [For (E, EB, EG) areas.]</b>	25 W (4 Ω)
[For (G, GN) areas.]	20 W (8 Ω)
<b>Intermodulation distortion</b>	
rated power at 60 Hz: 7 kHz=4:1, SMPTE	0.5% (8 Ω)
<b>Power bandwidth</b>	
both channels driven, –3 dB	10 Hz–40 kHz (8 Ω)
<b>Damping factor</b>	40 (8 Ω)
<b>Input sensitivity and impedance</b>	
PHONO	3 mV/47 kΩ
CD, VCR 1, VCR 2, TAPE/DCC	200 mV/22 kΩ
<b>S/N at rated power (8 Ω)</b>	
PHONO	70 dB (IHF, A: 80 dB)
CD, VCR 1, VCR 2, TAPE/DCC	75 dB (IHF, A: 88 dB)
<b>Frequency response</b>	
PHONO	RIAA standard curve (30 Hz–15 kHz) ±0.8 dB
CD, VCR 1, VCR 2, TAPE/DCC	10 Hz–40 kHz, ±3 dB
<b>Tone controls</b>	
BASS	50 Hz, +10 to –10 dB
TREBLE	20 kHz, +10 to –10 dB

## Output voltage

VCR 1 OUT, TAPE/DCC REC (OUT)	200 mV
Channel balance (250 Hz–6.3 kHz)	±1 dB
Channel separation	55 dB
Headphones output level and impedance	430 mV/330 Ω
<b>Load impedance</b>	
A or B [For (E, EB, EG) areas.]	4–16 Ω
[For (G, GN) areas.]	8–16 Ω
A and B	8–16 Ω

## ■ FM TUNER SECTION

<b>Frequency range</b>	87.50–108.00 MHz
<b>Sensitivity</b>	
S/N 30 dB	1.5 μV/75 Ω
S/N 26 dB	1.3 μV/75 Ω
S/N 20 dB	1.2 μV/75 Ω
<b>IHF usable sensitivity</b>	(IHF '58) 1.5 μV/75 Ω
<b>IHF 46 dB stereo quieting sensitivity</b>	22 μV/75 Ω
<b>Total harmonic distortion</b>	
MONO	0.2%
STEREO	0.3%
<b>S/N</b>	
MONO	60 dB (75 dB, IHF)
STEREO	58 dB (71 dB, IHF)
<b>Frequency response</b>	20 Hz–15 kHz, +1 dB, –2 dB
<b>Alternate channel selectivity</b>	
±400 kHz	65 dB
<b>Capture ratio</b>	1 dB
<b>Image rejection at 98 MHz</b>	40 dB
<b>IF rejection at 98 MHz</b>	70 dB
<b>Spurious response rejection at 98 MHz</b>	70 dB
<b>AM suppression</b>	50 dB
<b>Stereo separation</b>	
1 kHz	40 dB
<b>Carrier leak</b>	
19 kHz	–30 dB (–35 dB, IHF)
38 kHz	–50 dB (–55 dB, IHF)
<b>Channel balance (250 Hz–6.3 kHz)</b>	±1.5 dB
<b>Limiting point</b>	1.2 μV

# Technics®

<b>Bandwidth</b>	
IF amplifier	180 kHz
FM demodulator	1000 kHz
<b>Antenna terminal(s)</b>	75 Ω (unbalanced)

**■ AM TUNER SECTION**

• For (E, EB, G, GN) areas.

<b>Frequency range</b>	
MW	522–1611 kHz (9 kHz steps)
	530–1620 kHz (10 kHz steps)
LW	144–288 kHz

<b>Sensitivity</b>	
MW	20 μV, 330 μV/m
LW	45 μV

<b>Selectivity</b>	
MW (at 999 kHz)	55 dB
LW (at 252 kHz)	55 dB

<b>Image rejection</b>	
MW (at 999 kHz)	40 dB
LW (at 252 kHz)	40 dB

<b>IF rejection</b>	
MW (at 999 kHz)	55 dB
LW (at 252 kHz)	55 dB

• For (EG) area.	
<b>Frequency range</b>	522–1611 kHz (9 kHz steps)
	530–1620 kHz (10 kHz steps)

<b>Selectivity (S/N 20 dB)</b>	20 μV, 330 μV/m
--------------------------------	-----------------

<b>Selectivity at 999 kHz</b>	55 dB
-------------------------------	-------

<b>Image rejection at 999 kHz</b>	40 dB
-----------------------------------	-------

<b>IF rejection at 999 kHz</b>	55 dB
--------------------------------	-------

**■ CONTENTS**

	<b>Page</b>
ACCESSORIES .....	2
CAUTIONS FOR AC MAINS LEAD .....	3
PROTECTION CIRCUITRY .....	3
FRONT PANEL CONTROLS .....	4
EQUIPMENT CONNECTIONS .....	5, 6
REMOTE CONTROL OPERATION .....	7
BEFORE REPAIR AND ADJUSTMENT .....	7
DISASSEMBLY INSTRUCTIONS .....	8~11
FAN MOTOR TROUBLESHOOTING GUIDE .....	12

**■ VIDEO SECTION**

<b>Output voltage at 1 V input (unbalanced)</b>	1±0.1 Vp-p
---	------------

<b>Maximum input voltage</b>	1.5 Vp-p
------------------------------	----------

<b>Input/output impedance</b>	75 Ω (unbalanced)
-------------------------------	-------------------

**■ GENERAL**

<b>Power consumption</b>	
[For (E, EB, GN) areas.]	220 W
[For (EG) area.]	170 W
[For (G) area.]	210 W

<b>Power supply</b>	
[For (E, EB, EG, GN) areas.]	AC 50/60 Hz, 230–240 V
[For (G) area.]	AC 50/60 Hz, 110–127 V/220–240 V

<b>Dimensions (W×H×D)</b>	430×136×352 mm
---------------------------	----------------

<b>Weight</b>	8.6 kg
---------------	--------

**■ REMOTE CONTROL TRANSMITTER**

<b>Control keys</b>	38 keys
---------------------	---------

<b>Dimensions (W×H×D)</b>	62×27×175 mm
---------------------------	--------------

<b>Weight (including batteries)</b>	106 g (3.2 oz)
-------------------------------------	----------------

<b>Power source</b>	Two UM-4/AAA (Panasonic R03/LR03 or equivalent)
---------------------	--

**Notes:**

- Design and specifications are subject to change without notice. Weight and dimensions are approximate.
- Total harmonic distortions is measured by the digital spectrum analyzer.

	<b>Page</b>
BLOCK DIAGRAM .....	13~16
SCHEMATIC DIAGRAM .....	17~31
PRINTED CIRCUIT BOARDS .....	32~37
WIRING CONNECTION DIAGRAM .....	38
TERMINAL FUNCTION OF IC .....	39
REPLACEMENT PARTS LIST .....	40~42, 48
CABINET PARTS LOCATION .....	43, 44
RESISTORS AND CAPACITORS .....	45~48
PACKAGING .....	48

**■ ACCESSORIES**

AC power supply cord..... 1 pc.  
[RJA0019-2K [VJA0733 (EB)]  
(E, EG, G)]

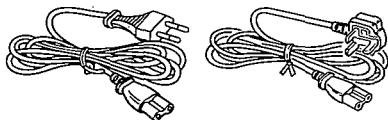

[RJA0036-K (GN)]

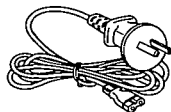

FM indoor antenna ..... 1 pc.  
(RSA0007)



Attachment plug..... 1 pc.  
[SJP9009 (EB)]



AM loop antenna set..... 1 pc.  
(RSA0010)  
• AM antenna holder..... 1 pc.  
(RMN0244)  
• Screw..... 1 pc.  
(XTN3+10AFZ)

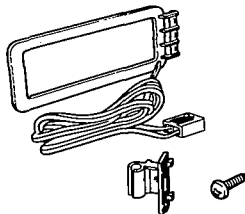

Power plug adaptor..... 1 pc.  
[SJP5213-1 (G)]



Remote control transmitter ..... 1 pc.  
(RAK-SA114XH)



Batteries for remote control  
transmitter ..... 2 pcs.  
("AAA", R03)



**Note:** These are available on sale route.

Antena plug..... 1 pc.  
[RFE0014 (G, GN)]

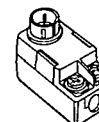



## CAUTIONS FOR AC MAINS LEAD

### ("EB" area code model only)

For your safety, please read the following text carefully.

This appliance is supplied with a moulded three pin mains plug for your safety and convenience.

A 5-ampere fuse is fitted in this plug.

Should the fuse need to be replaced please ensure that the replacement fuse has a rating of 5-ampere and that it is approved by ASTA or BSI to BS1362. Check for the ASTA mark  or the BSI mark  on the body of the fuse.

If the plug contains a removable fuse cover you must ensure that it is refitted when the fuse is replaced.

If you lose the fuse cover the plug must not be used until a replacement cover is obtained.

A replacement fuse cover can be purchased from your local dealer.

### CAUTION!

IF THE FITTED MOULDED PLUG IS UNSUITABLE FOR THE SOCKET OUTLET IN YOUR HOME THEN THE FUSE SHOULD BE REMOVED AND THE PLUG CUT OFF AND DISPOSED OF SAFELY.

THERE IS A DANGER OF SEVERE ELECTRICAL SHOCK IF THE CUT OFF PLUG IS INSERTED INTO ANY 13-AMPERE SOCKET.

If a new plug is to be fitted please observe the wiring code as shown below.

If in any doubt please consult a qualified electrician.

### IMPORTANT

The wires in this mains lead are coloured in accordance with the following code:

Blue: Neutral

Brown: Live

As the colours of the wires in the mains lead of this appliance may not correspond with the coloured markings identifying the terminals in your plug, proceed as follows:

The wire which is coloured BLUE must be connected to the terminal in the plug which is marked with the letter N or coloured BLACK.

The wire which is coloured BROWN must be connected to the terminal in the plug which is marked with the letter L or coloured RED.

Under no circumstances should either of these wires be connected to the earth terminal of the three pin plug, marked with the letter E or the Earth Symbol .

### Before use

Remove the connector cover as follows.

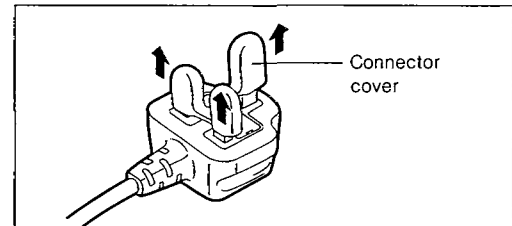

### How to replace the fuse

1. Remove the fuse cover with a screwdriver.

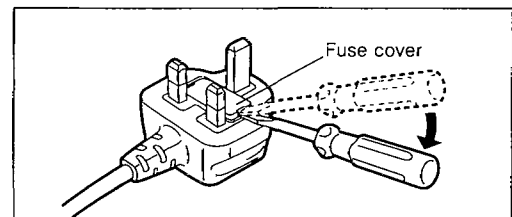

2. Replace the fuse and attach the fuse cover

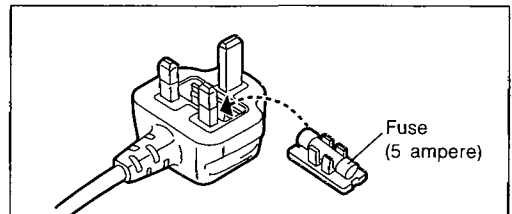

### [For (GN) area.]

THIS TUNER/RECEIVER IS CAPABLE OF RECEIVING THE NEW AM STEREO BROADCASTS FROM THE AM BAND RADIO STATIONS. HOWEVER LIKE MANY TUNERS AND RECEIVERS CURRENTLY AVAILABLE ON THE MARKET IT WILL REPRODUCE THIS AM STEREO SIGNAL ONLY IN AM MONO, WHICH, IN EFFECT, IS OF NO LESSER QUALITY THAN YOUR EXISTING AM MONO TUNER/RECEIVER.

## PROTECTION CIRCUITRY

The protection circuitry may have operated if either of the following conditions is noticed:

- No sound is heard when the power is turned on.
- Sound stops during a performance.

The function of this circuitry is to prevent circuitry damage if, for example, the positive and negative speaker connection wires are "shorted", or if speaker systems with an impedance less than the indicated rated impedance of the amplifier are used.

If this occurs, follow the procedure outlines below:

1. Turn off the power.
2. Determine the cause of the problem and correct it.
3. Turn on the power once again after one minute.

### Note:

When the protection circuitry functions, the unit will not operate unless the power is first turned off and then on again.

## FRONT PANEL CONTROLS

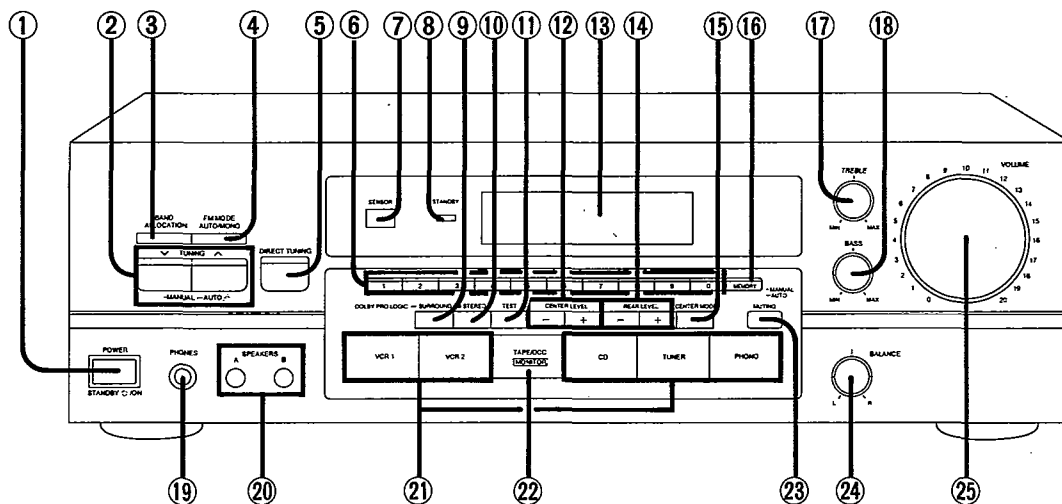

No.	Name
-----	------

- |   |   |
|---|---|
| ① | <b>Power "STANDBY <math>\text{\textcircled{I}}</math> / ON" switch (POWER, STANDBY <math>\text{\textcircled{I}}</math> / ON)</b><br>Press to switch the unit from on to standby mode or vice versa. In standby mode, the unit is still consuming a small amount of power. |
| ② | <b>Tuning control (TUNING)</b>  |
| ③ | <b>Band select button (BAND)</b>  |
| ④ | <b>FM mode select button (FM MODE)</b>  |
| ⑤ | <b>Direct tuning button (DIRECT TUNING)</b>   |
| ⑥ | <b>Numeric buttons (1-0)</b>  |
| ⑦ | <b>Remote control signal receptor (SENSOR)</b>  |
| ⑧ | <b>"STANDBY" indicator</b><br>When the unit is connected to the AC mains supply, this indicator lights up in standby mode and goes out when the unit is turned on.  |
| ⑨ | <b>DOLBY PRO LOGIC SURROUND ON/OFF button (SURROUND)</b>  |
| ⑩ | <b>DOLBY PRO LOGIC 3 STEREO ON/OFF button (3 STEREO)</b>  |
| ⑪ | <b>Test signal ON/OFF button (TEST)</b>   |

No.	Name
-----	------

- |   |   |
|---|---|
| ⑫ | <b>Center level adjust button (CENTER LEVEL)</b>  |
| ⑬ | <b>Display</b>                                    |
| ⑭ | <b>Rear level adjust button (REAR LEVEL)</b>      |
| ⑮ | <b>Center mode select button (CENTER MODE)</b>    |
| ⑯ | <b>Memory button (MEMORY)</b>                     |
| ⑰ | <b>Treble control (TREBLE)</b>                    |
| ⑱ | <b>Bass control (BASS)</b>                        |
| ⑲ | <b>Headphone jack (PHONES)</b>                    |
| ⑳ | <b>Speaker select buttons (SPEAKERS)</b>          |
| ㉑ | <b>Input select buttons</b>                       |
| ㉒ | <b>Tape/DCC monitor button (TAPE/DCC MONITOR)</b> |
| ㉓ | <b>Muting button (MUTING)</b>                     |
| ㉔ | <b>Balance control (BALANCE)</b>                  |
| ㉕ | <b>Volume control (VOLUME)</b>                    |

# EQUIPMENT CONNECTIONS

## Connecting audio equipment

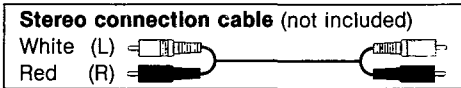

**CD player (or CD changer)**  
 (not included)

**Tape deck or digital compact cassette deck (DCC)**  
 (not included)

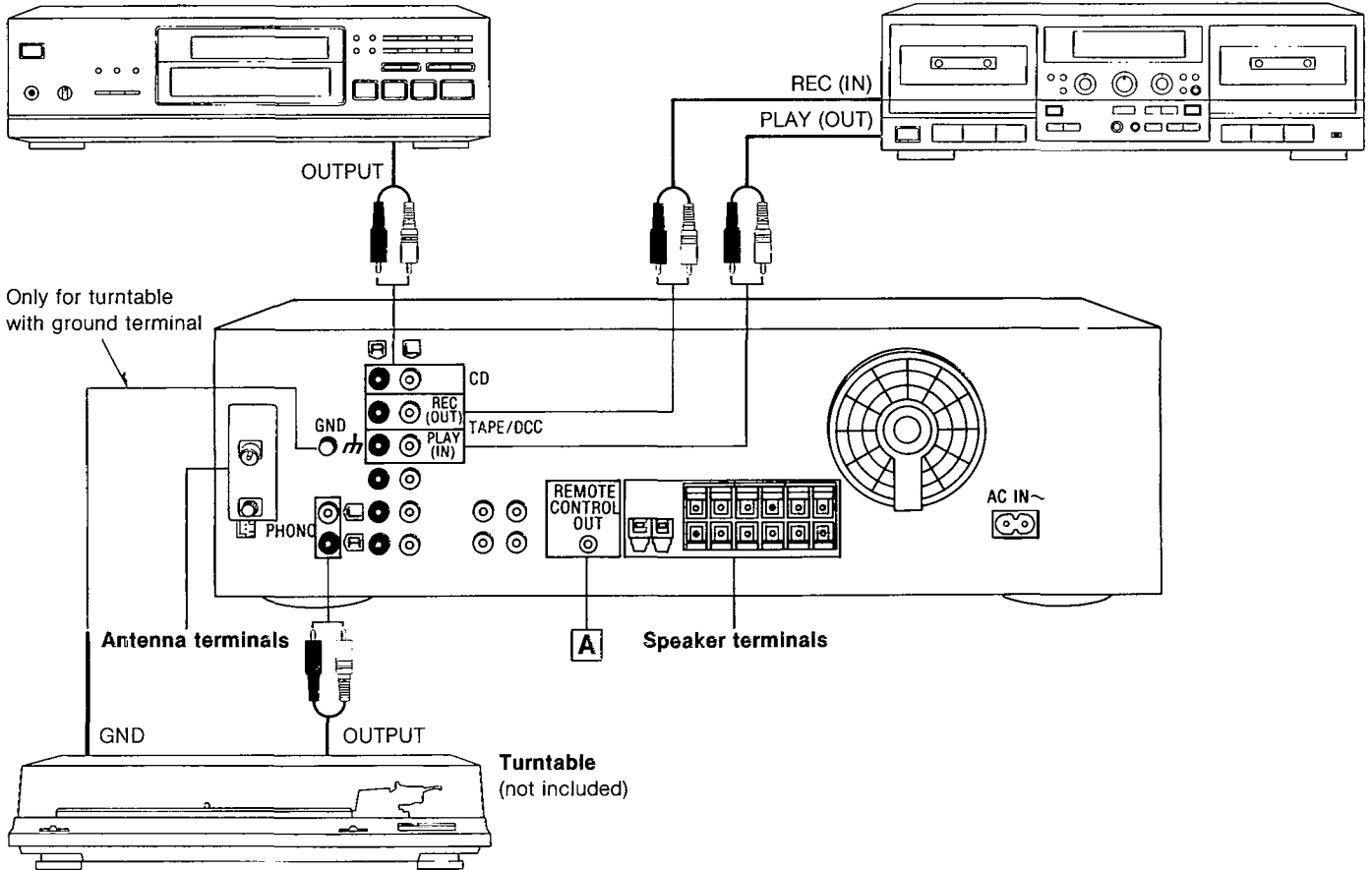

### A "REMOTE CONTROL OUT" terminal

Connect the connection cable for the remote control to a Technics tape deck and/or CD player (or CD changer) which has the appropriate remote control terminal as shown below. If a tape deck is not being used, the CD player (or CD changer) can be connected directly (dotted line).

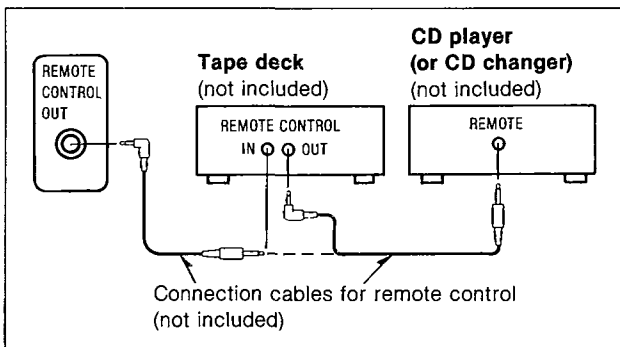

For a CD player (or CD changer) with a remote control sensor the above connection is not necessary.

### To set the power voltage

[For (G) area only.]



Set the voltage adjustment to the voltage setting for the area in which the unit will be used.

#### Note

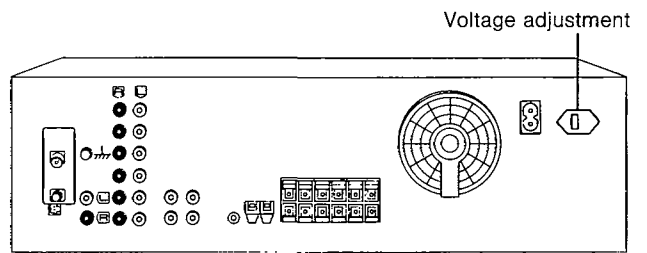
Note that this unit will be seriously damaged if this setting is not made correctly.



## Connecting video equipment

**Stereo connection cable (not included)**  
 White (L)   
 Red (R) 

**Second VCR (for playback only)**  
 (not included)

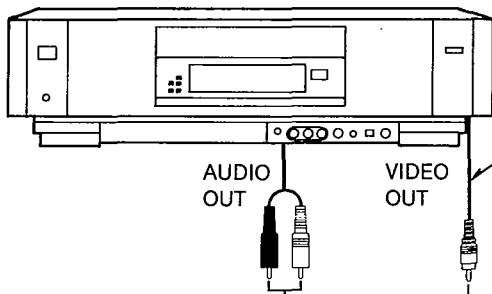

**Monitor TV**  
 (not included)

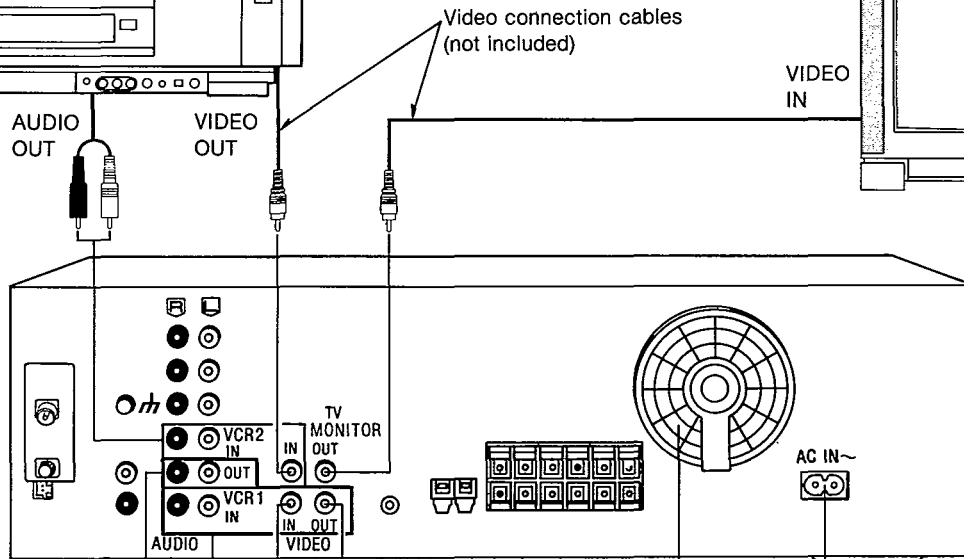
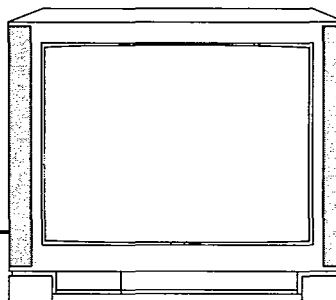

**Cooling fan**

The cooling fan operates at high power output levels only.

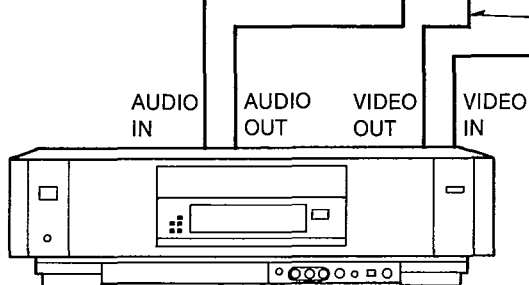

**VCR**  
 (not included)

**To connect a video deck with 21 pin scart terminal**

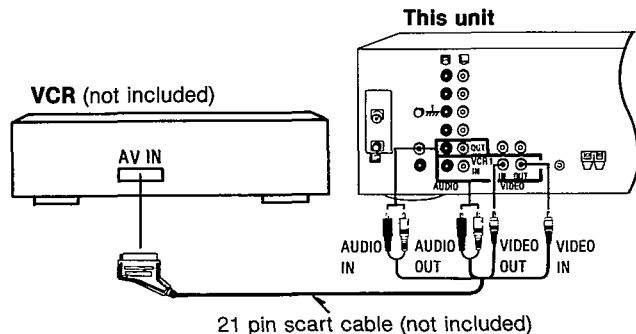

AC power supply cord (included)

Connect this cord after all other cables and cords are connected.

**[For except (GN) area only.]**

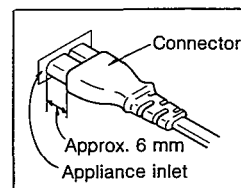

Even when the connector is perfectly inserted, the front part of the connector jut out as shown in the drawing. However there is no problem using the unit.

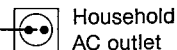

**[For (EB) area only.]**







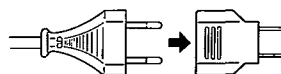



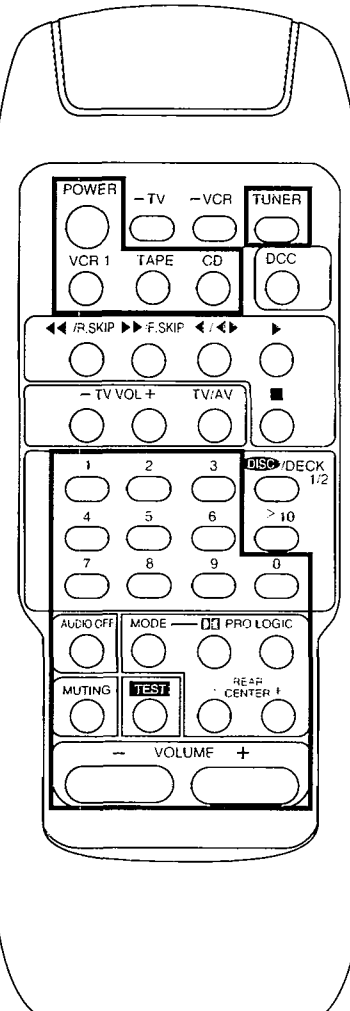





BE SURE TO READ THE CAUTION FOR THE AC POWER SUPPLY CORD ON PAGE 2 BEFORE CONNECTION.

**[For (G) area only.]**

If the power plug will not fit your socket, use the power plug adaptor (included).

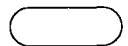
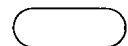

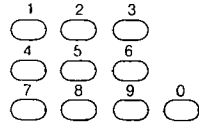
## REMOTE CONTROL OPERATION

	To turn the unit ON/OFF	POWER 
	To select an input source	TUNER    CD    TAPE    VCR 1    
	To select the Dolby Pro Logic mode	MODE —  PRO LOGIC    Changes as follows each time the button is pressed. → SURROUND → 3 STEREO → (OFF)
	To adjust the output level of the rear speakers	When the SURROUND mode is ON   — REAR +
	To adjust the output level of the center speaker	When the 3 STEREO or SURROUND mode is ON   — CENTER +
	To output a test signal	When the 3 STEREO or SURROUND mode is ON <b>TEST</b>  Press once more to stop the test signal.
	To mute the sound level	MUTING    Press once more to return to the original volume. 
	To adjust the volume level	— VOLUME +  
	If your unit is equipped with the New Technics Remote Control System (see below)	
	To turn the system OFF	AUDIO OFF 
	<b>To listen to radio broadcasts</b>	
	<p>Specify the preset channel using the numeric button(s).</p> <p>TUNER → </p> <p>(Example: Channel 12)  Within 2 sec.</p>	

## BEFORE REPAIR AND ADJUSTMENT

Disconnect AC power, Discharge both Power Supply Capacitors C703 and C704 (63V 6800 $\mu$ F/75V 7500 $\mu$ F), C705 and C706 (50V 3300 $\mu$ F) through a 10 $\Omega$ , 5W resistor to ground.

DO NOT SHORT-CIRCUIT DIRECTLY (with a screwdriver blade, for instance), as this may destroy solid state devices. After repairs are completed, restore power gradually using a variac, to avoid overcurrent.

Current consumption at 50Hz/60Hz in NO SIGNAL mode should be shown below with respect to supply voltage AC 230V/240V.

Power supply voltage	AC 230V		AC 240V		AC 110–127V		AC 220–240V	
Consumed current 50/60Hz	50Hz	140~400mA	50Hz	150~420mA	50Hz	300~800mA	50Hz	150~420mA
	60Hz	112~320mA	60Hz	120~336mA	60Hz	240~640mA	60Hz	120~336mA

# DISASSEMBLY INSTRUCTIONS

## OPERATION CHECKS AND MAIN COMPONENT REPLACEMENT PROCEDURES

### NOTE

1. This section describes procedures for checking the operation of the major printed circuit boards and replacing the main components.
2. For reassembly after operation checks or replacement, reverse the respective procedures. Special reassembly procedures are described only when required.
3. Select items from the following index when checks or replacement are required.
4. Illustrated screws are equivalent to actual size.
5. [ ] indicates parts No.

### Contents

1. Checking for the volume P.C.B., tuner P.C.B., IN/OUT terminal P.C.B. and operation P.C.B. ....	page. 8.
2. Checking for the main P.C.B. ....	9.
3. Replacement for the power IC and regulator transistor .....	10.

### 1. Checking for the volume P.C.B., tuner P.C.B., IN/OUT terminal P.C.B. and operation P.C.B.

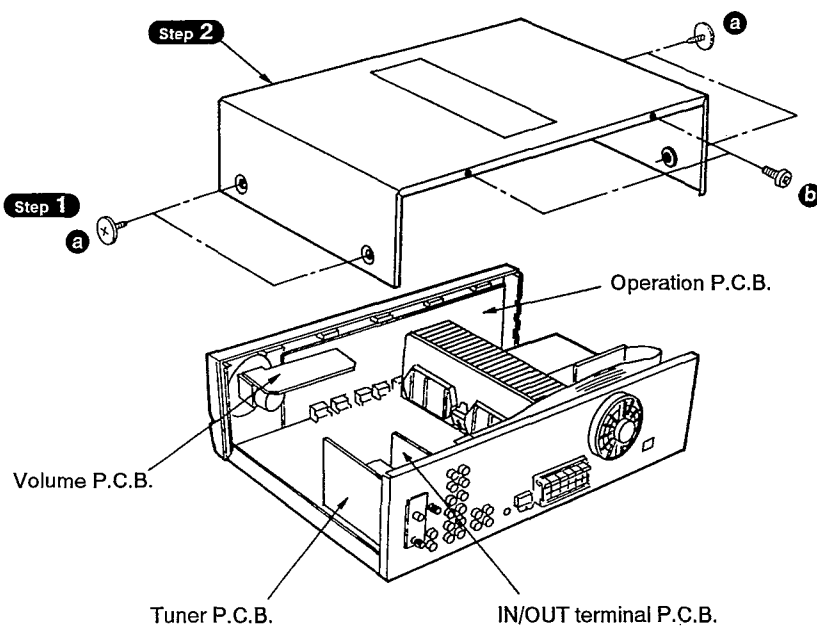

	<b>a</b>
[RHD30035-K1] (Black)	
	<b>b</b>
[XTBS3+8JFZ1] (Black)	



2. Checking for the main P.C.B.

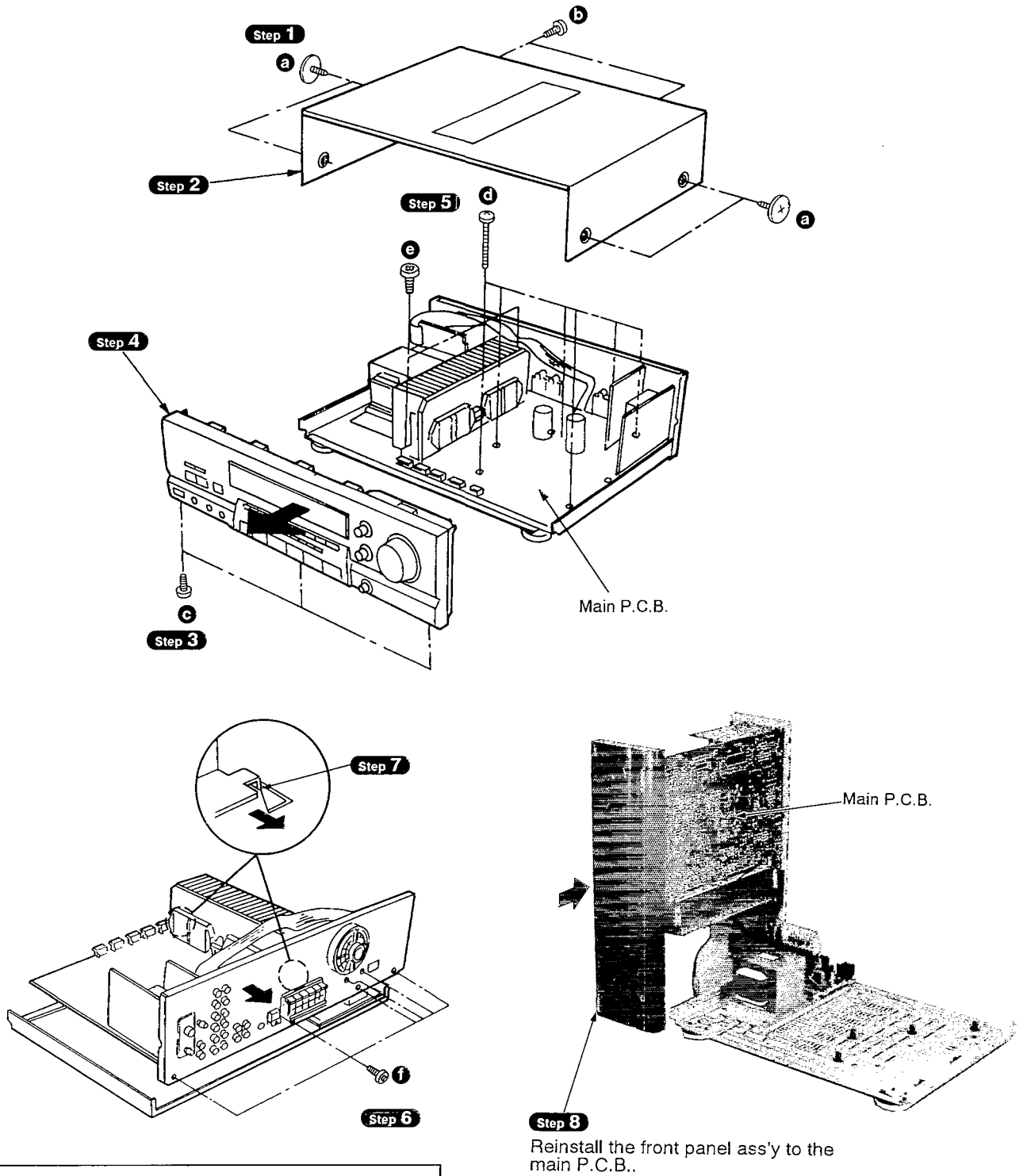

a

[RHD30035-K1] (Black)



d

[XTB3+20JFZ] (Black)



b, c, f

[XTBS3+8JFZ1] (Black)

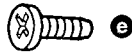

e

[XTB3+8JFZ] (Black)

### 3. Replacement for the power IC and regulator transistor

**Step 1** Follow the disassembly procedure described in item 1 on page 8.

**Step 2** Cut the joints as shown below.(6 portions)

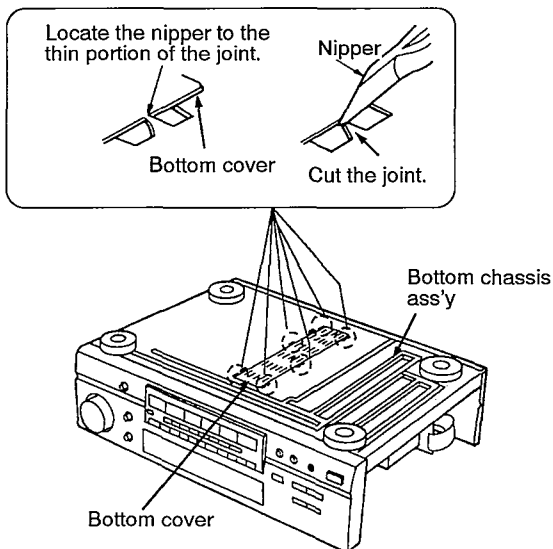

**Step 4** Unsolder the terminals of power IC or regulator transistor.

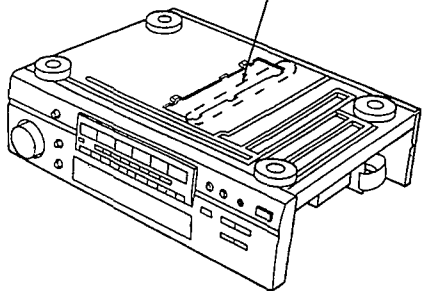

**Step 7** Fix the bottom cover with screw.

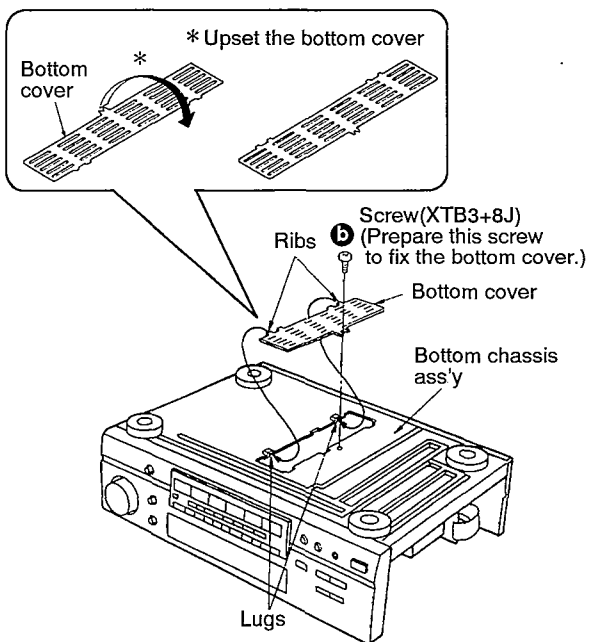

**Step 3** Fold the joints.(6 portions)

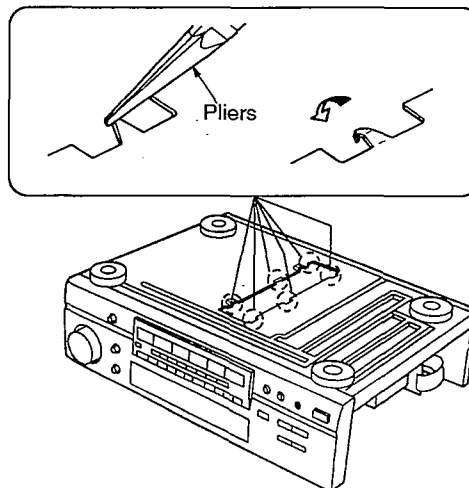

**Step 5** Remove the 6 screws.

**Step 6** Remove the transistor holder.

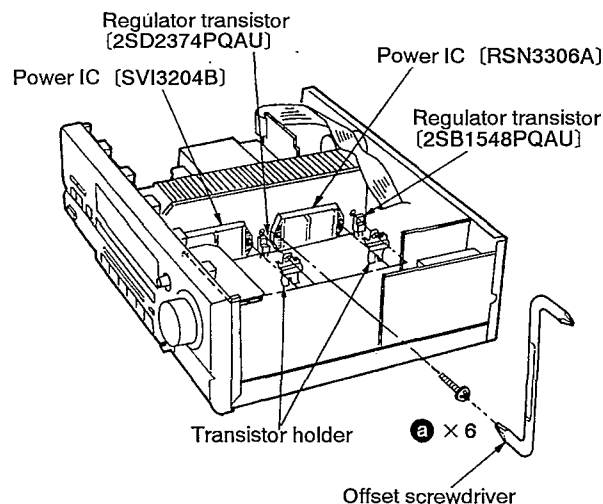

#### CAUTION

- After replacing the power IC or regulator transistor, apply a sufficient quantity of compound grease (RFKX0002/ SZZ0L15) between the heat sink and the power IC or regulator transistor(Radiation of power IC and regulator transistor).
- Tighten enough the screws (a) after replacing the power IC or regulator transistor. Otherwise, the heat radiation works little.
- When installing or removing the power IC or transistor holder, be sure to use an offset screwdriver.



[XTW3+15T]



[XTB3+8J] (Black)

(Prepare this screw to fix the bottom cover.)

**CAUTION:**

1. A long straight screwdriver cannot be used for removal or mounting since its long grip interferes with the neighboring P.C.B.(See Fig.1)
2. A short straight screwdriver may be used for removal, but cannot be used for mounting because the limited space in the unit will not allow sufficient tightening torque. (See Fig.2)

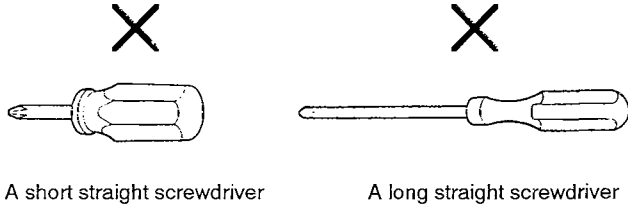

A short straight screwdriver

A long straight screwdriver

**Fig.2**

3. Insufficient tightening will cause poor heat dissipation from the power IC and regulator transistor and, in the worst case, may lead their thermal breakdown. (See Fig.2)

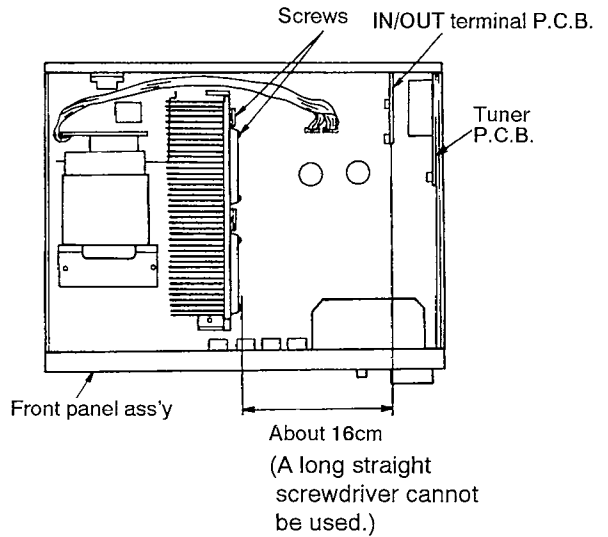

**Fig.1**

**—OFFSET SCREWDRIVER—**

- The PROTO offset screwdriver No.34- 1/4 is recommended for use in the application above.

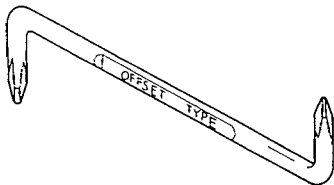

No.		
34 1/4	1 & 2	4 3/4"

- The address of PROTO International Sales is as follows.



**International Sales**

International Sales Office  
Stanley-Proto Industrial Tools  
14117 Industrial Park Blvd.  
Covington, GA 30209 U.S.A.  
Fax: 706-786-4387  
Phone: 706-787-3800

Australia, New Zealand & South Pacific  
Stanley-Proto Industrial Tools  
P.O.Box 10  
400 Whitehorse Road  
Nunweding 3131  
Victoria, Australia  
Fax: 61-3-894-1173  
Phone: 61-3-878-9244

Singapore, Indonesia, Philippines, Korea, Hong Kong, Malaysia, China.  
Stanley-Proto Asia Pacific  
12 Gul Drive  
Singapore 2262  
Fax: 65-861-3206  
Phone: 65-862-0883

Thailand  
Stanley-Proto Thailand Ltd.  
1017 Moo 13 Bangnatrad Highway, Tambol Bankaew Amphur Bangplee Samutprakarn, Thailand  
Fax: 66-2-316-6071  
Phone: 66-2-316-8655

Japan  
Stanley Works Japan  
2-7-16 Hyakunin-Cho  
Shinjuku-ku  
Tokyo 160 Japan  
Fax: 81-3-3360-8456  
Phone: 81-3-3360-8458

Mexico  
Herramientas Stanley S.A.  
DE C.V.  
Apartado Postal 675  
72030 Puebla, Pue, Mexico  
Fax: 52-22-494-4880  
Phone: 52-22-495-300

South & Central America, Puerto Rico, The Caribbean  
Stanley Inter-America  
2101 N.W. 84th Ave.  
Miami, Florida 33122  
Fax: 305-594-4261  
Phone: 305-591-3828

Europe  
Stanley-Proto Europe  
Woodside, Sheffield  
S39PD  
England  
Fax: 44-742-739-038  
Phone: 44-742-768-888

Canada  
Stanley-Proto Canada  
1100 Corporate Drive  
Burlington, Ontario  
Canada, L7L 5R6  
Fax: 416-335-0075  
Phone: 416-335-0075

Middle East, Mediterranean & Africa  
Stanley-MEMA  
Cory House The Ring  
Bracknell Berkshire  
RG 12 1A2  
England  
Fax: 44-344-485-526  
Phone: 44-344-51813

# FAN MOTOR TROUBLESHOOTING GUIDE

The Model SA-GX470 employ fan motor error sensing electronics.

If the cooling fan is not operation and "OVER LOAD" is displayed on the FL display, check the fan motor and its driving circuit.

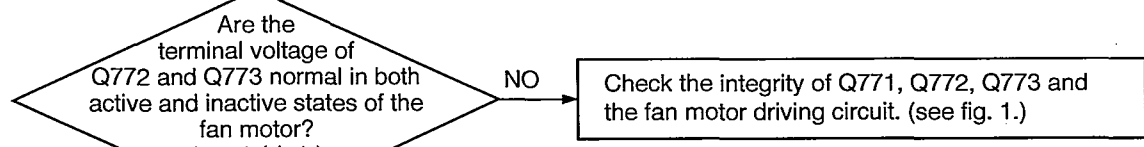
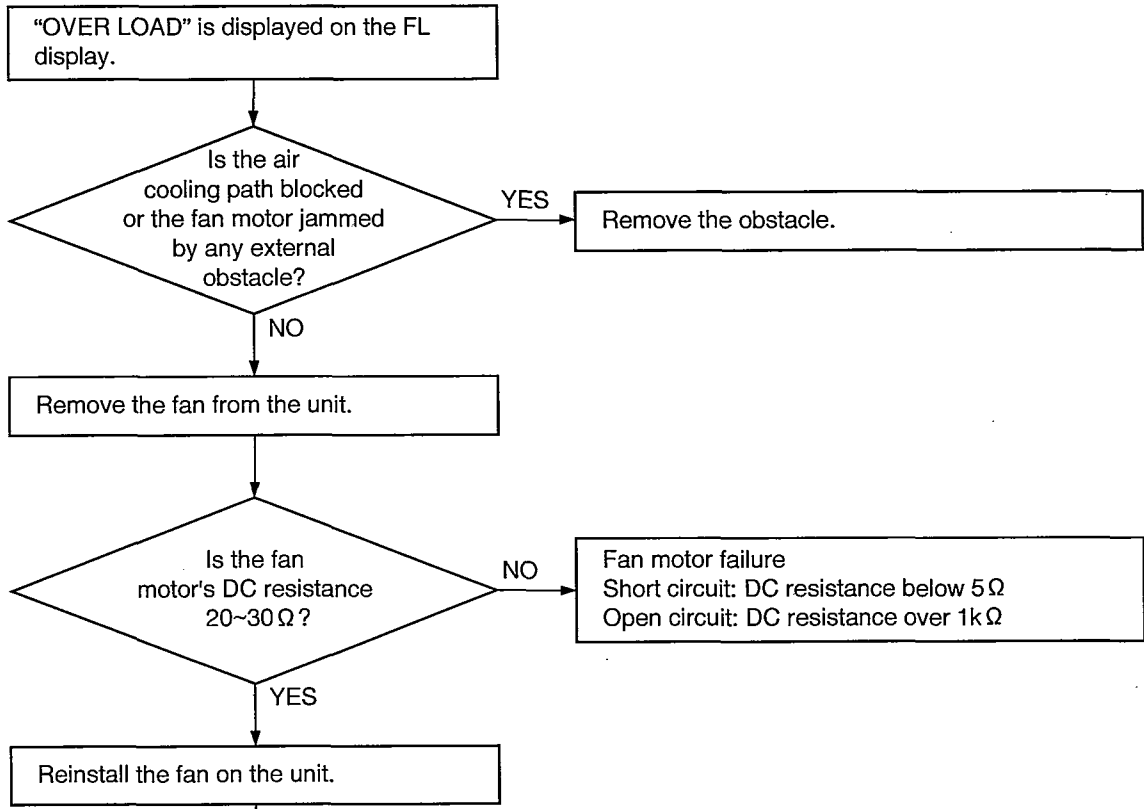

(Voltage table)

		fan. off	fan. on
Q771	E	0V	0V
	C	-0.65V	-0.1V
	B	0V	-0.65V
Q772	E	0V	0V
	C	-0.1V	-8.2V
	B	-0.65V	-0.1V
Q773	E	0V	-7.5V
	C	-14V	-13.2V
	B	-0.1V	-8.2V

(Table 1)

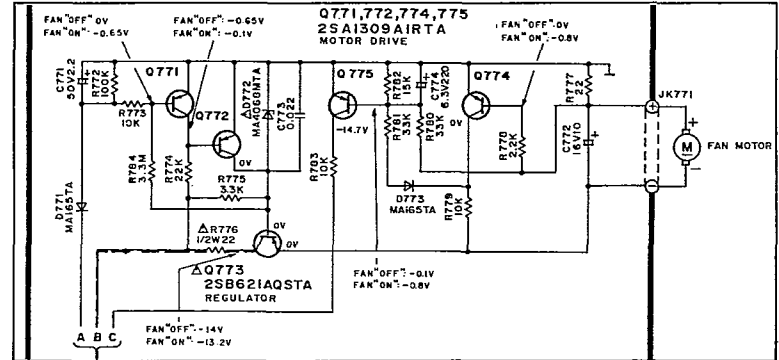
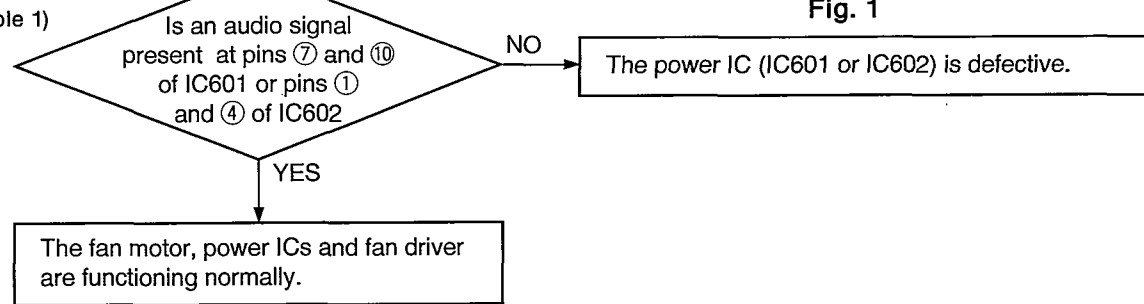
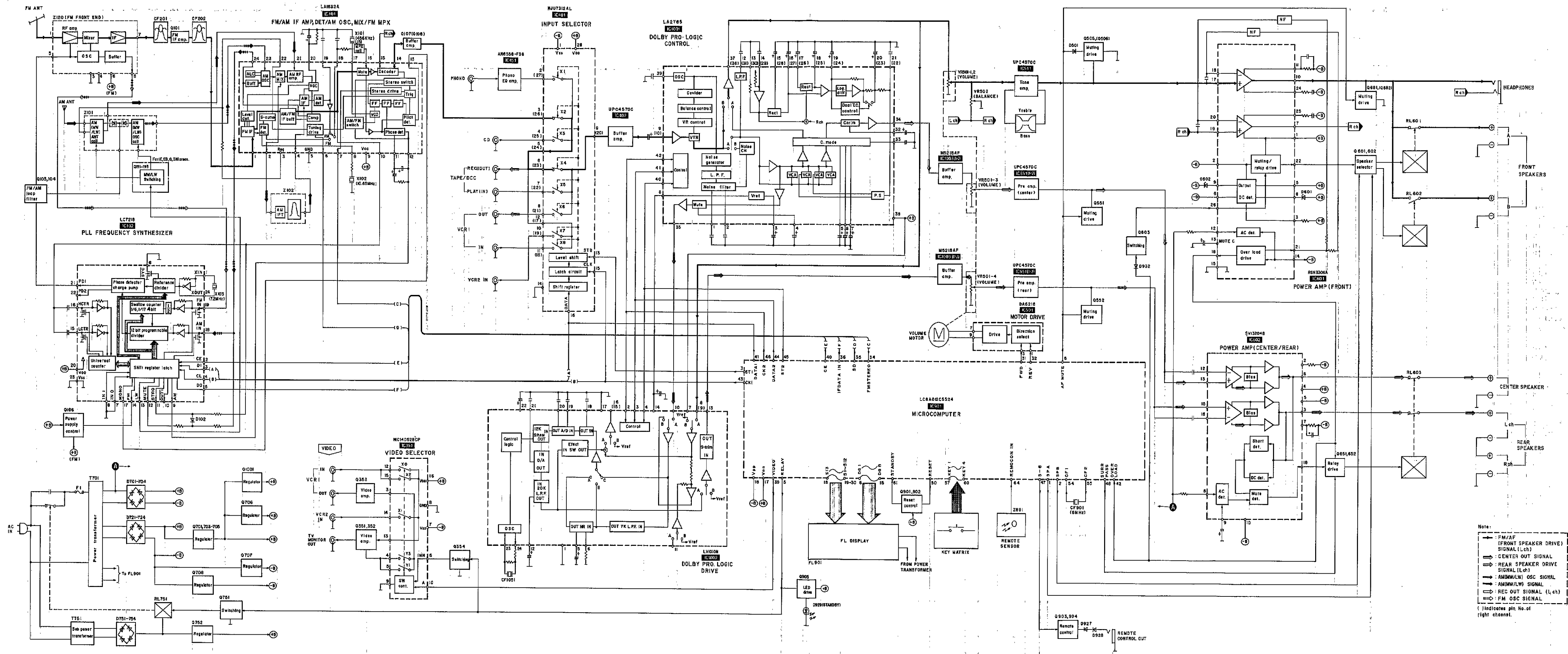

Fig. 1



BLOCK DIAGRAM



Note:

- FM/AM (FRONT SPEAKER DRIVE) SIGNAL (Lch)
- CENTER OUT SIGNAL
- REAR SPEAKER DRIVE SIGNAL (Lch)
- AM/AM/LW/OSC SIGNAL
- REC OUT SIGNAL (Lch)
- FM OSC SIGNAL

( indicates pin No. of right channel.

**SCHEMATIC DIAGRAM** (Parts list on pages 40~42, 45~48.)

(This schematic diagram may be modified at any time with the development of new technology.)

**Note 1:**

- S701 : Voltage adjustment switch in "240V" position. (110V ↔ 127V ↔ 220V ↔ 240V) [For (G) area only.]
- S946 : Numeric (5) switch.
- S947 : Center level adjust (CENTER LEVEL (-)) switch.
- S948 : Test signal ON/OFF (TEST) switch.
- S949 : Numeric (4) switch.
- S950 : Numeric (6) switch.
- S951 : Center level adjust (CENTER LEVEL (+)) switch.
- S952 : Numeric (7) switch.
- S953 : Rear level adjust (REAR LEVEL (-)) switch.
- S954 : Input select (CD) switch.
- S955 : Input select (TUNER) switch.
- S956 : Center mode select (CENTER MODE) switch.
- S957 : Numeric (9) switch.
- S960 : Rear level adjust (REAR LEVEL (+)) switch.
- S961 : Numeric (8) switch.
- S962 : Numeric (0) switch.
- S964 : Input select (PHONO) switch.
- S966 : Memory (MEMORY) switch.
- S967 : Muting (MUTING) switch.
- S970 : Tape/DCC monitor (TAPE/DCC MONITOR) switch.
- S971 : Input select (VCR 2) switch.
- S972 : Input select (VCR 1) switch.
- S973 : Speaker select (SPEAKER B) switch.
- S974 : FM mode select (FM MODE) switch.
- S975 : Band select (BAND) switch.
- S976 : Direct tuning (DIRECT TUNING) switch.
- S977 : Tuning control (TUNING V) switch.
- S978 : Power "STANDBY & ION" (POWER, STANDBY & ION) switch.

- S980 : Dolby pro logic 3 stereo ON/OFF (3 STEREO) switch.
- S981 : Speaker select (SPEAKER A) switch.
- S982 : Dolby pro logic surround ON/OFF (SURROUND) switch.

- S983 : Numeric (3) switch.
- S984 : Numeric (2) switch.
- S985 : Numeric (1) switch.
- S987 : Tuning control (TUNING A) switch.

**Signal line**

- ▬▬▬▬▬▬ : FM OSC signal
- ▬▬▬▬▬▬ : AM (MW/LW) OSC signal
- ▬▬▬▬▬▬ : Rec out signal (Lch)
- ▬▬▬▬▬▬ : Rear speaker drive signal (Lch)
- ▬▬▬▬▬▬ : Positive voltage lines
- ▬▬▬▬▬▬ : Negative voltage lines
- ▬▬▬▬▬▬ : FM signal
- ▬▬▬▬▬▬ : AM (MW/LW) signal
- ▬▬▬▬▬▬ : AF signal (Lch)
- ▬▬▬▬▬▬ : Center speaker drive signal (Lch)

**Important safety notice**  
Components identified by  $\Delta$  mark have special characteristics important for safety. Furthermore, special parts which have purposes of fire-retardant (resistors), high-quality sound (capacitors), low-noise (resistors), etc. are used as occasion calls. When replacing any of components, be sure to use only manufacturer's specified parts shown in the parts list.

All voltage values shown in circuitry are DC voltage in FM signal (Stereo signal) reception mode.  
\* Figures in ( ) stand for DC-voltage in AM (MW) signal reception mode.  
\* Figures in < > stand for DC-voltage in LW signal reception mode.

**Caution!**

- IC and LSI are sensitive to static electricity. Secondary trouble can be prevented by taking care during repair.
- Cover the parts boxes made of plastics with aluminum foil.
- Ground the soldering iron.
- Put a conductive mat on the work table.
- Do not touch the legs of IC or LSI with the fingers directly.

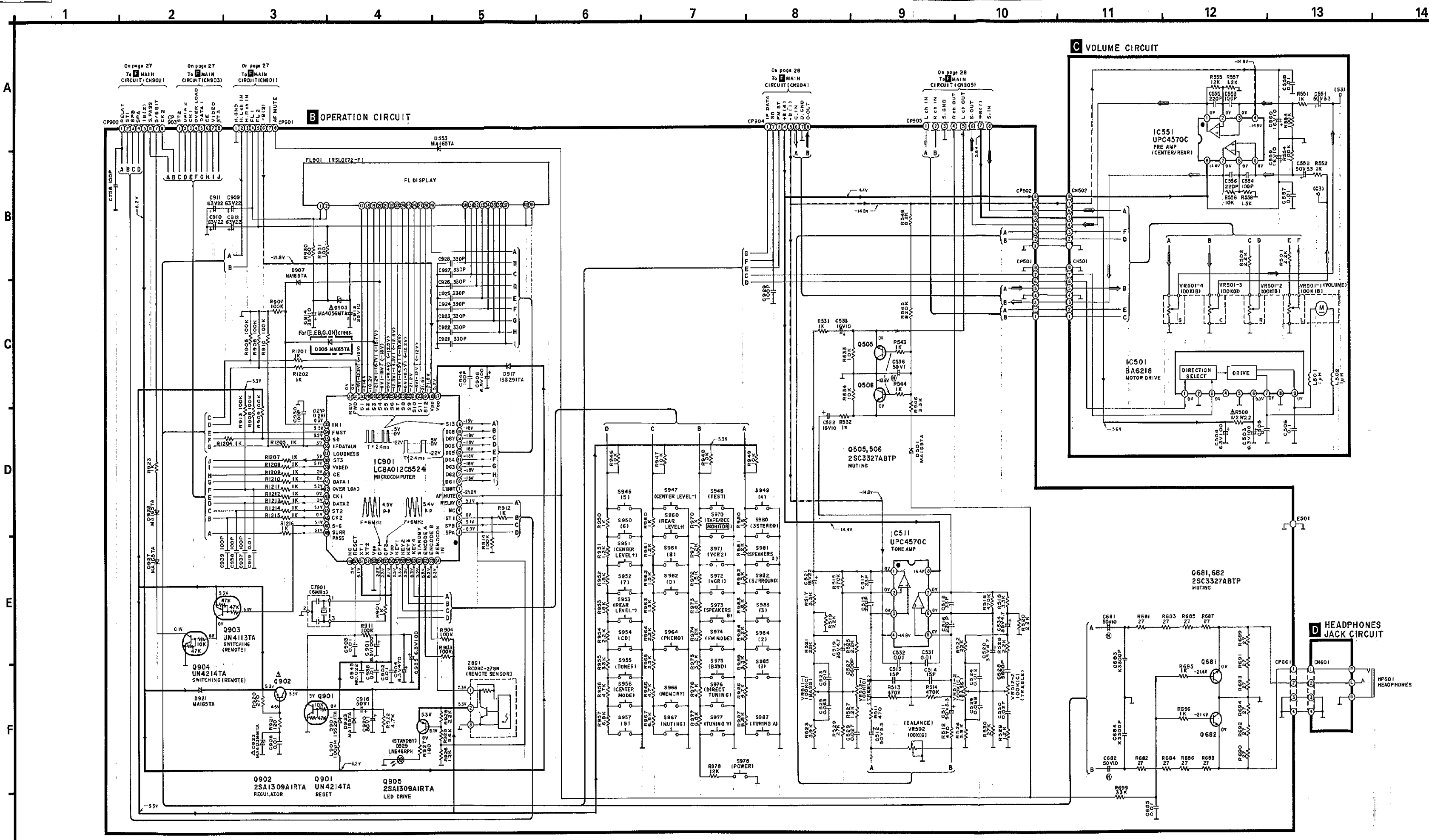



Note 2:

- Signal line
- FM OSC signal
- AM (MW/LW) OSC signal
- Rec out signal (Lch)
- Rear speaker drive signal (Lch)
- Positive voltage lines
- Negative voltage lines
- FM signal
- AM (MW/LW) signal
- AF signal (Lch)
- Center speaker drive signal (Lch)

replacing any of components, be sure to use only manufacturer's specified parts shown in the parts list.

- All voltage values shown in circuitry are DC voltage in FM signal (Stereo signal) reception mode.
- \* Figures in ( ) stand for DC-voltage in AM (MW) signal reception mode.
- \* Figures in < > stand for DC-voltage in LW signal reception mode.

- Caution!**
- IC and LSI are sensitive to static electricity. Secondary trouble can be prevented by taking care during repair.
- Cover the parts boxes made of plastics with aluminum foil.
- Ground the soldering iron.
- Put a conductive mat on the work table.
- Do not touch the legs of IC or LSI with the fingers directly.

**Important safety notice**  
Components identified by  $\Delta$  mark have special characteristics important for safety. Furthermore, special parts which have purposes of fire-retardant (resistors), high-quality sound (capacitors), low-noise (resistors), etc. are used as occasion calls. When

Power Source Circuit For C630nd.

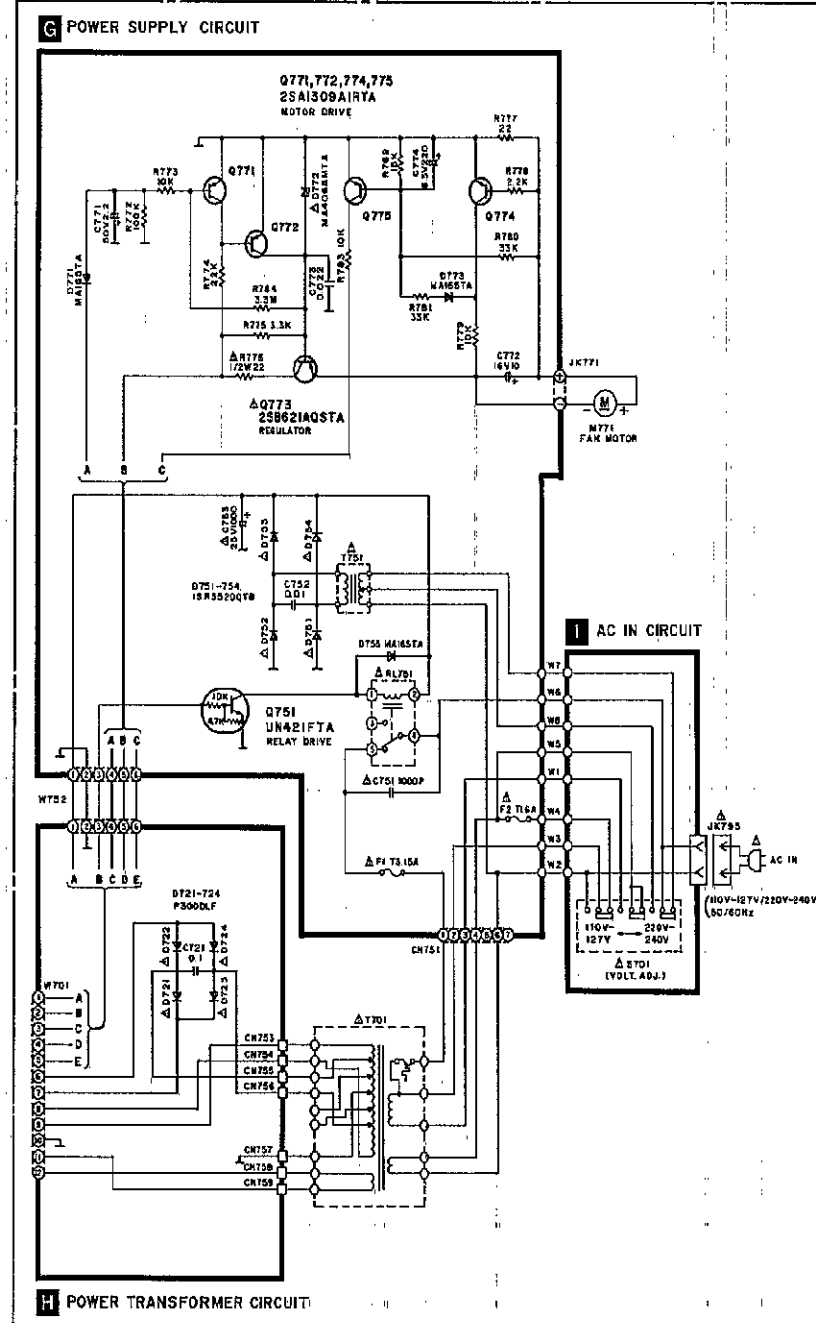

E IN/OUT TERMINAL CIRCUIT

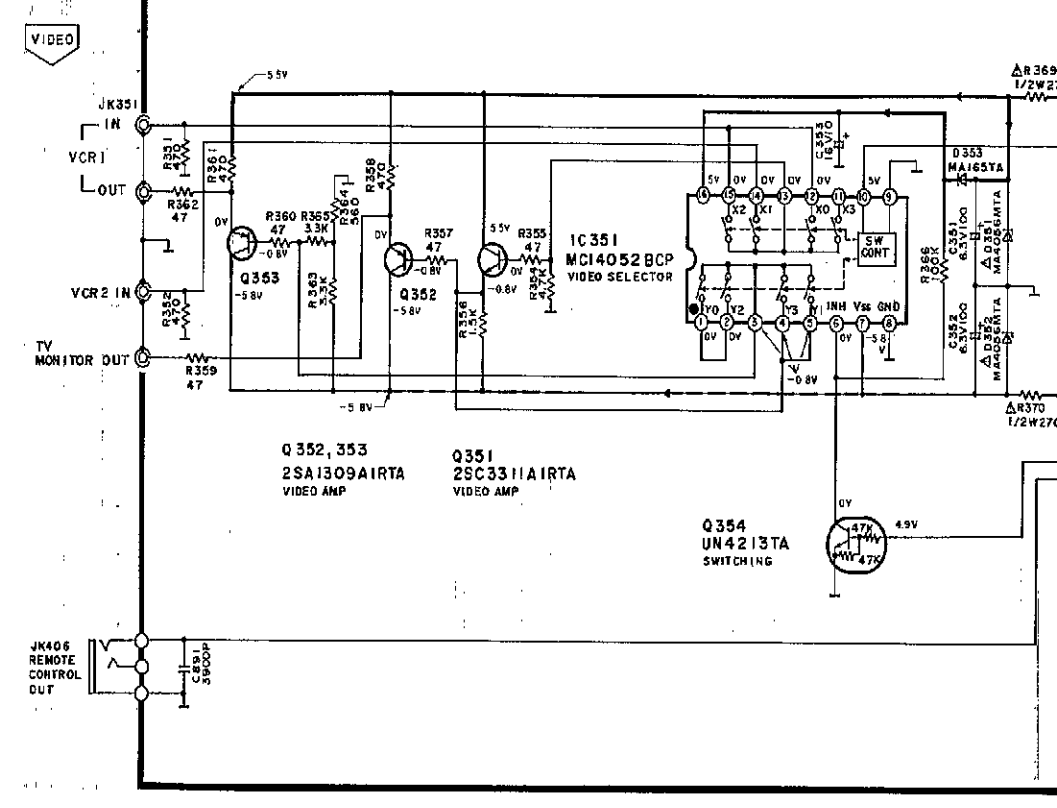
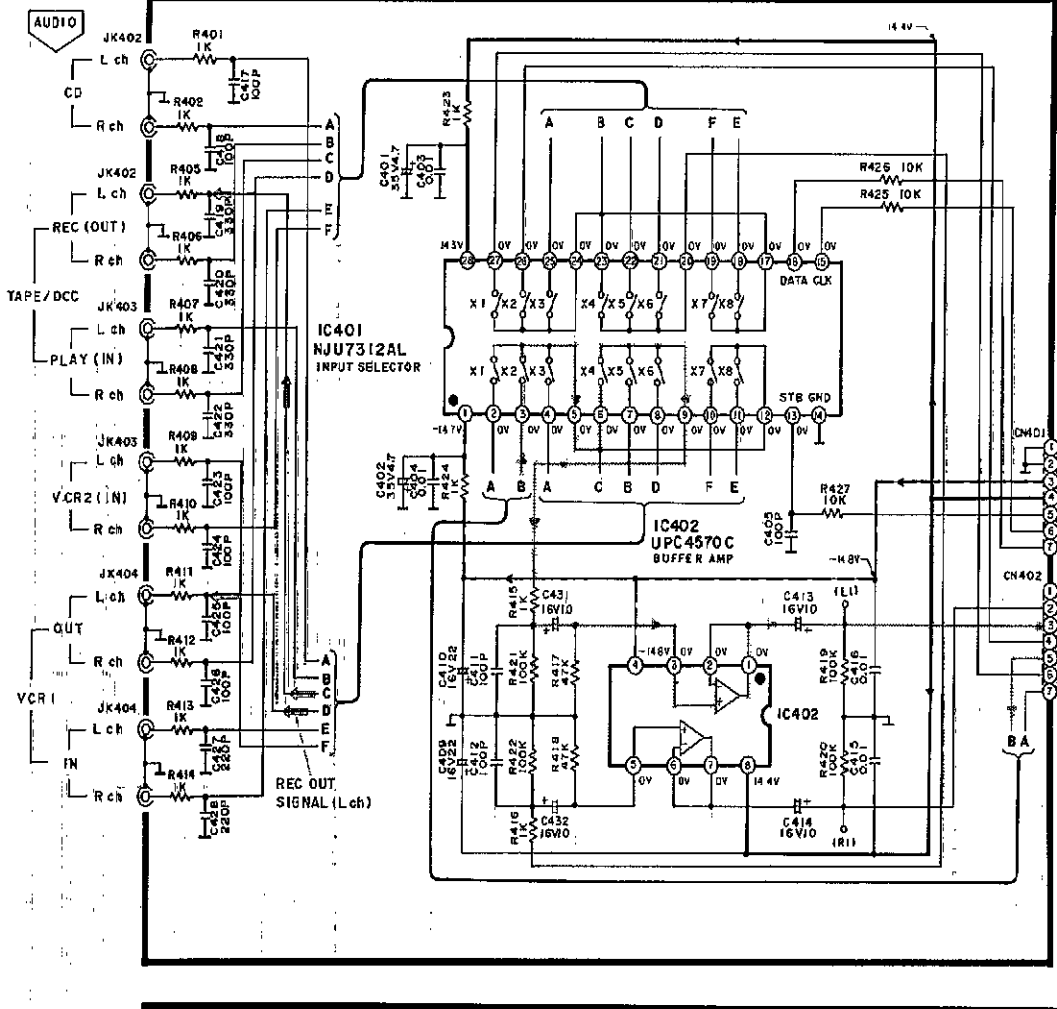

F MAIN CIRCUIT (VIDEO AMP/PHONO EQ AMP/DOLBY PRO LOGIC/BUFFER AMP/REGULATOR/POWER AMP)

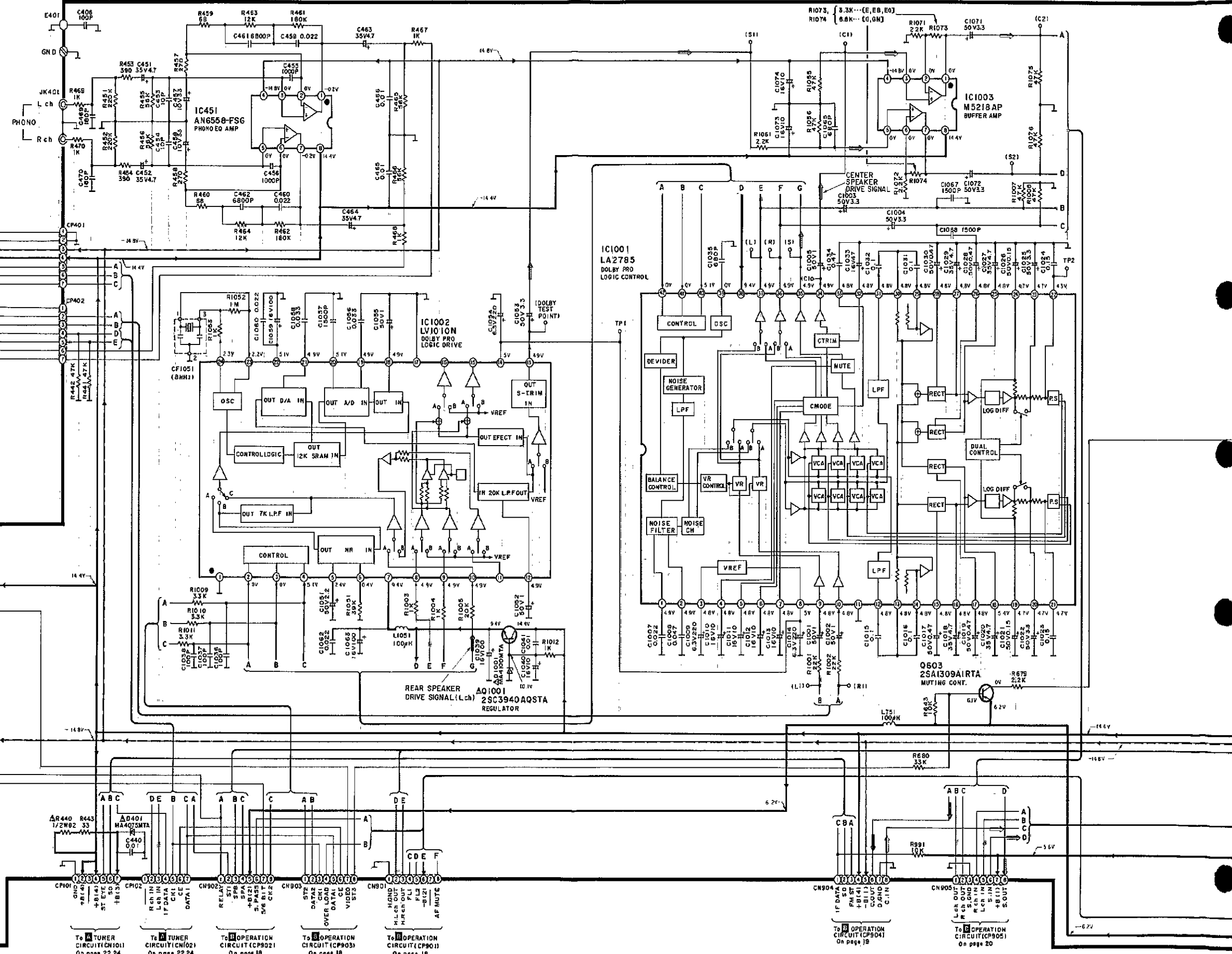





PRINTED CIRCUIT BOARDS

1 2 3 4 5 6 7 8 9 10 11 12 13 14

A

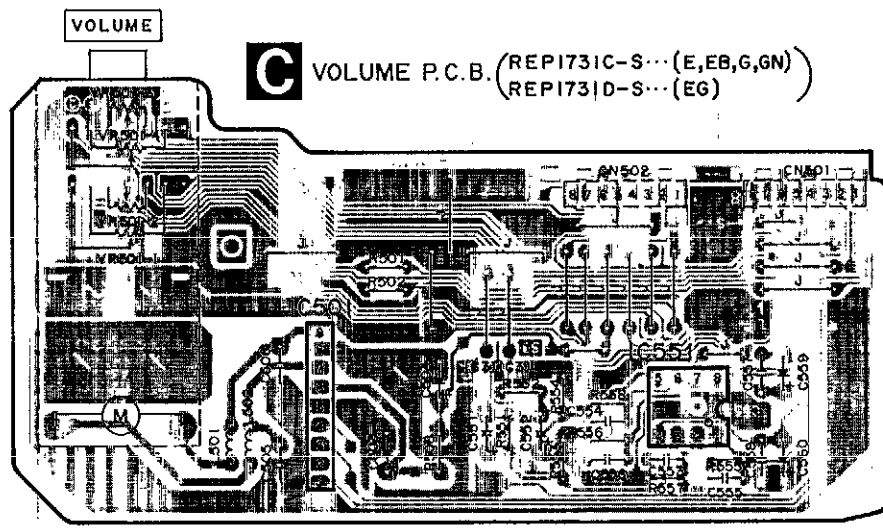

**C** VOLUME P.C.B. (REP1731C-S... (E,EB,G,GN)  
REP1731D-S... (EG)

B

**D** HEADPHONES JACK P.C.B. (REP1731C-S... (E,EB,G,GN)  
REP1731D-S... (EG)

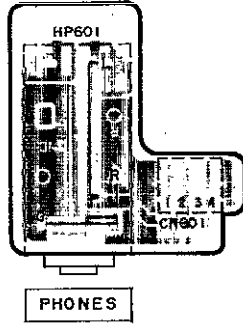

C

D

**B** OPERATION P.C.B. (REP1731C-S... (E,EB,G,GN)  
REP1731D-S... (EG)

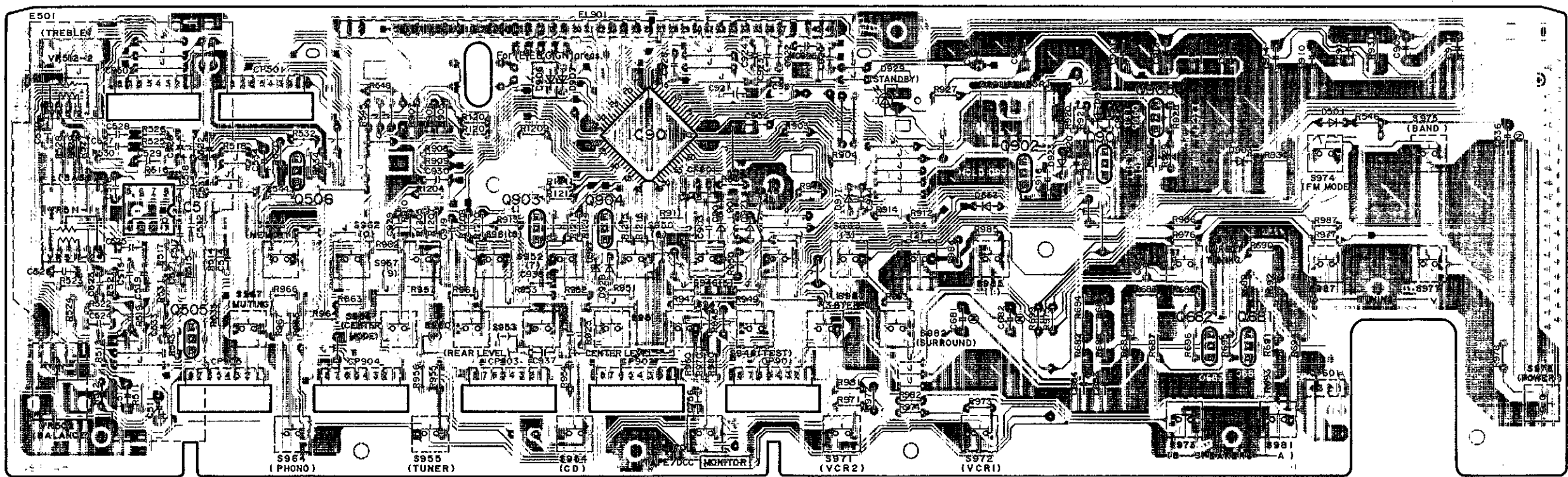

E

F

**A** TUNER P.C.B. For (E,EB,G,GN) areas. (REP1750B-T)

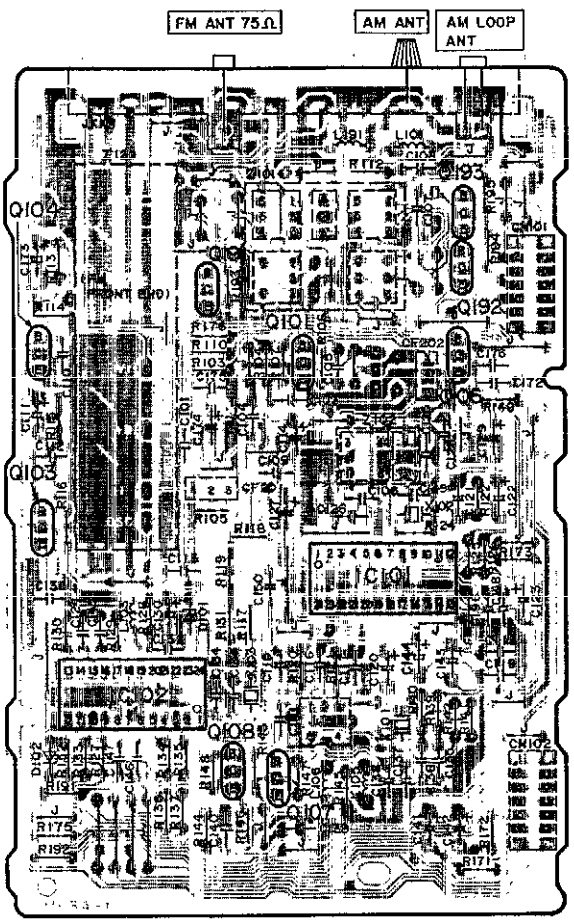

**A** TUNER P.C.B. For (EG) area. (REP1750C-T)

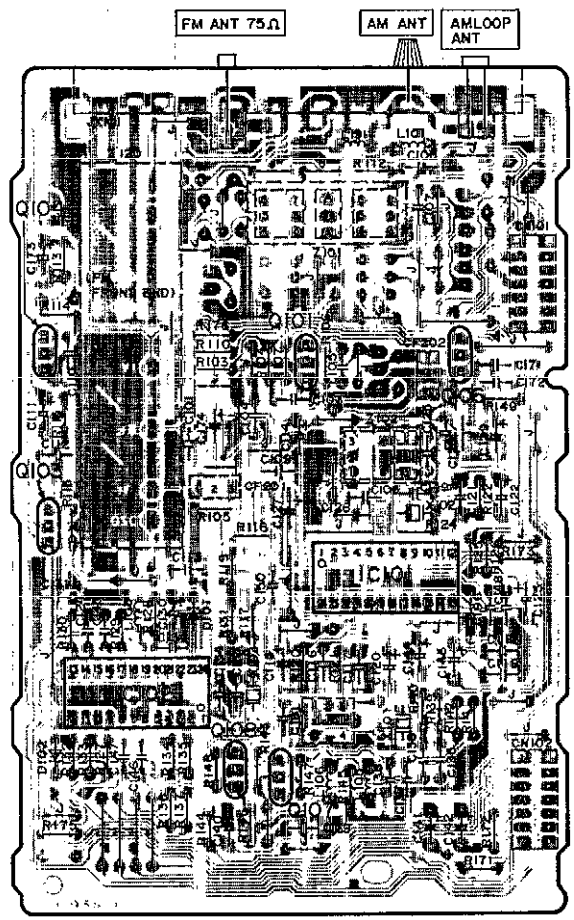

**E** IN/OUT TERMINAL P.C.B. (REP1732C-P... (E,EB)  
REP1732D-P... (EG)  
REP1732E-P... (G)  
REP1732F-P... (GN)

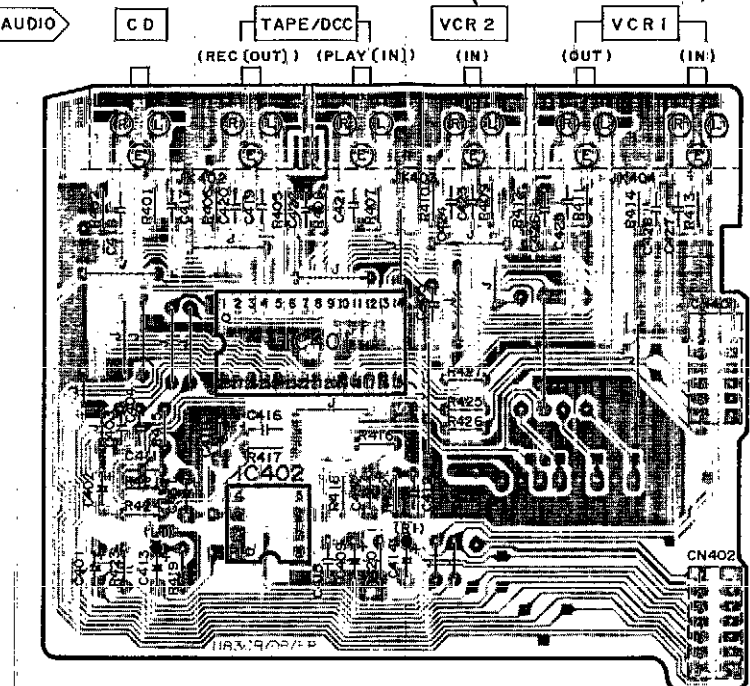

**H** POWER TRANSFORMER P.C.B. (REP1732C-P... (E,EB)  
REP1732D-P... (EG)  
REP1732F-P... (GN)

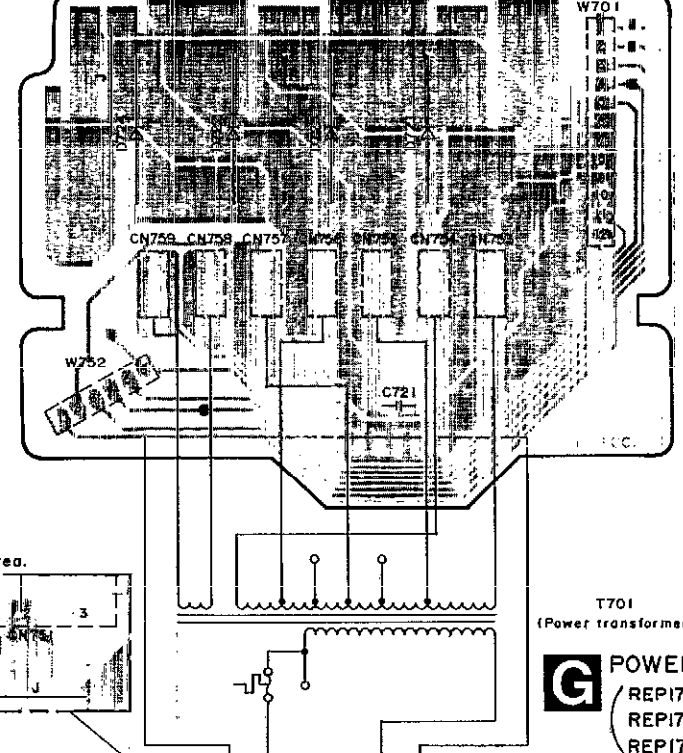

For (EG) area.

**G** POWER SUPPLY P.C.B. (REP1732C-P... (E,EB)  
REP1732D-P... (EG)  
REP1732F-P... (GN)

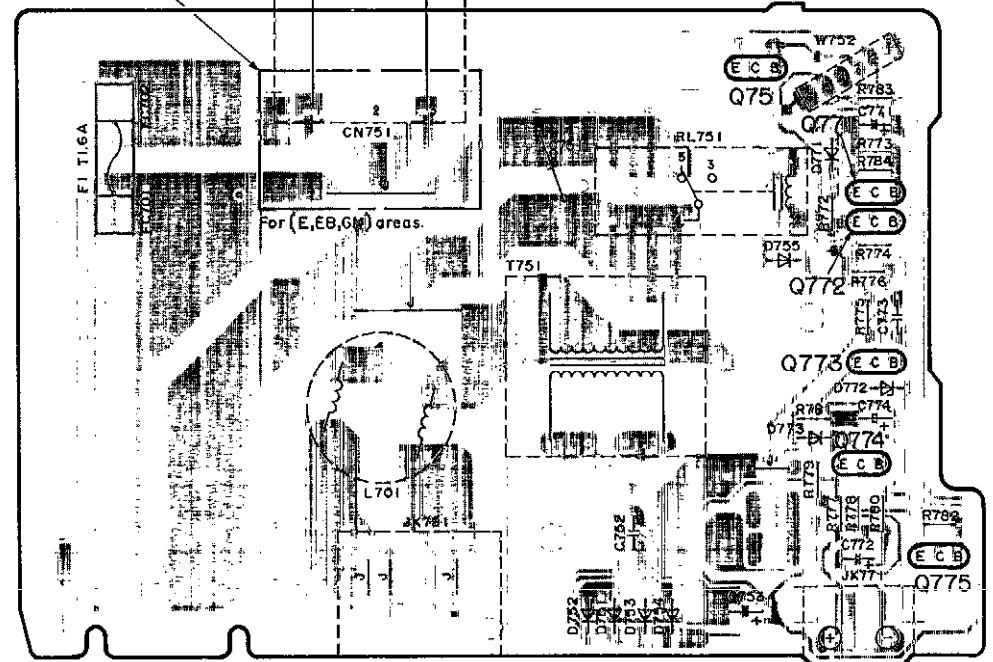

AC IN (230-240V... (E,EB,GN)  
230V... (EG)  
50/60Hz

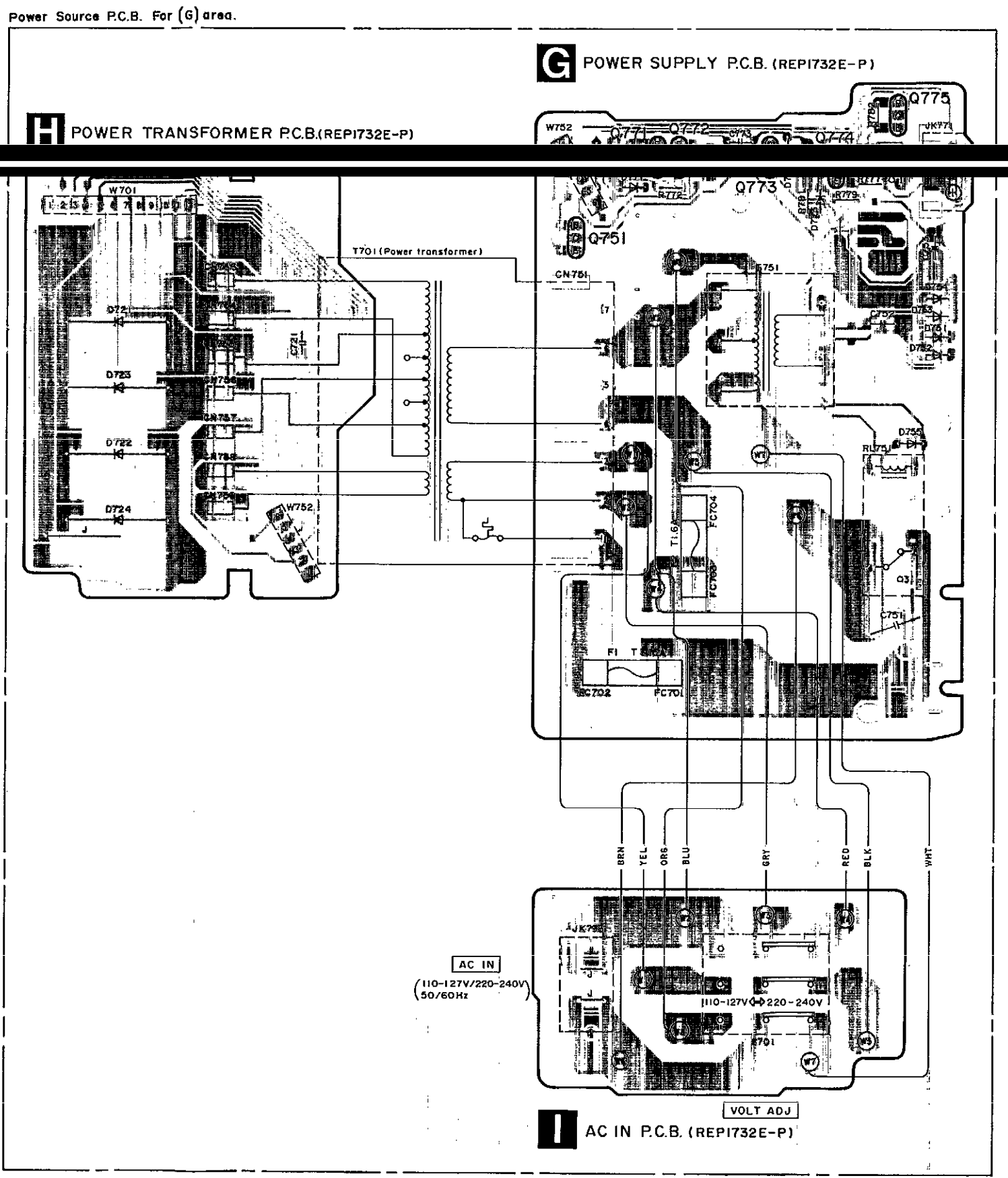
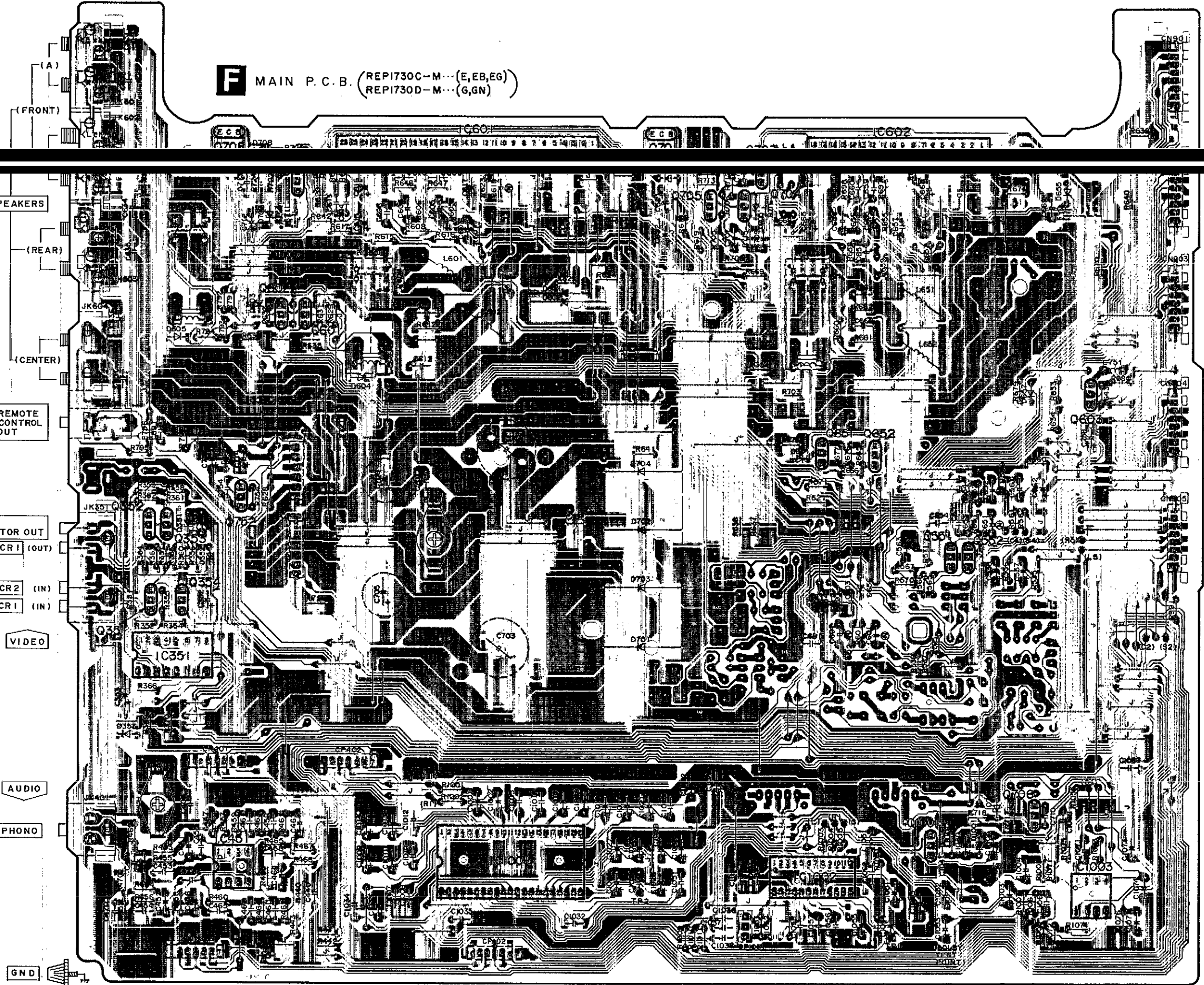

X.

■ WIRING CONNECTION DIAGRAM

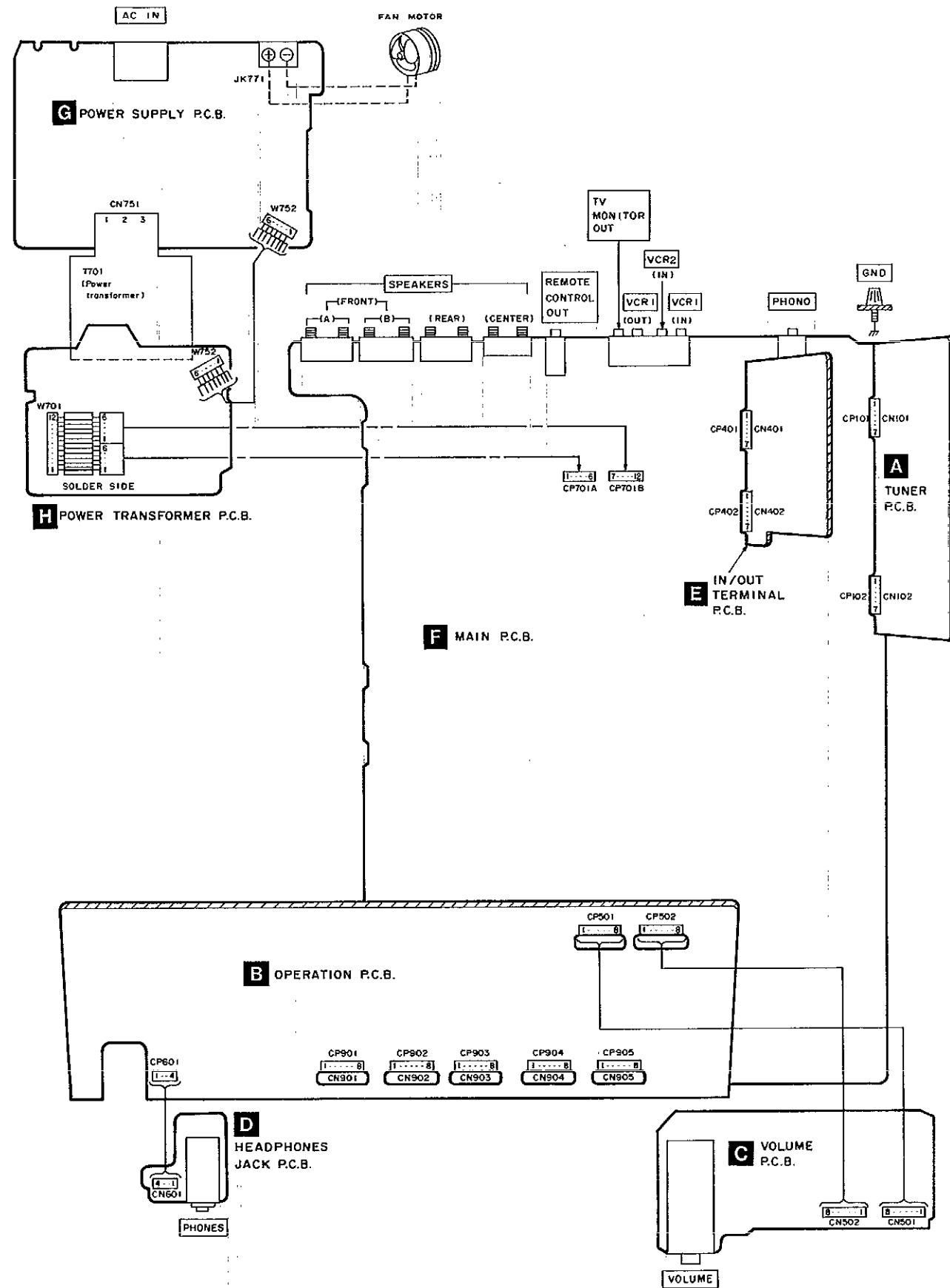

■ TERMINAL FUNCTION OF IC

• IC901 (LC8A012C5524): Microcomputer

Pin No.	Mark	I/O Division	Function
1	SPA	O	Speaker select control terminal
2	SPB	O	Speaker select control terminal
3	ST1	O	Level shift control terminal
4	NC	—	Not used, open
5	RELAY	O	Relay control terminal
6	AF MUTE	O	Muting control terminal
7	LIMIT	O	Muting control (-20dB) terminal
8	DG1	O	Digit signal of FL display
15	DG8	O	Digit signal of FL display
16	S13	O	Segment signal of FL display
17	VDD	I	Power supply terminal
18	VPP	I	Power supply terminal of FL display
19	S12	O	Segment signal of FL display
30	S1	O	Segment signal of FL display
31	FWD	O	Rotation control terminal of volume motor
32	REV	O	Rotation control terminal of volume motor
33	IN1	—	Not used, connected to resistor
34	FMST	I	Stereo signal detect terminal
35	SD	I	Received signal detect terminal
36	IFDATAIN	I	Serial data signal
37	LOUDNESS	—	Not used, open
38	ST3	O	Level shift control terminal
39	VIDEO	O	Video selector control terminal
40	CE	O	Chip enable terminal

Pin No.	Mark	I/O Division	Function
41	DATA1	O	Serial data signal
42	OVER LOAD	I	Over load detect terminal
43	CK1	O	Serial clock signal
44	DATA2	O	Serial data signal
45	ST2	O	Level shift control terminal
46	CK2	O	Serial clock signal
47	5-6	O	Remote control terminal
48	SURR PASS	O	Level shift control terminal
49	NC	—	Test terminal
50	RESET	I	Reset detect terminal
51	XT1	I	Not used, connected to power supply
52	XT2	—	Not used, open
53	VSS	—	GND terminal
54	CF1	I	Crystal oscillator
55	CF2	O	Terminal (6 MHz)
56	VDD	I	Power supply terminal
57	KEY1	I	Key matrix detect terminal
60	KEY4	I	
61	STANDBY	I	Power detect terminal
62	ENCODE A	I	Not used, connected to power supply
63	ENCODE B	I	
64	REMOCON IN	I	Remote control terminal

■ REPLACEMENT PARTS LIST

Notes: \*Important safety notice:  
 Components identified by Δ mark have special characteristics important for safety. Furthermore, special parts which have purposes of fire-retardant (resistors), high-quality sound (capacitors), low-noise (resistors), etc. are used. When replacing any of components, be sure to use only manufacturer's specified parts shown in the parts list. \*The parenthesized indications in the Remarks columns specify the areas. (Refer to the cover page for area.) Parts without these indications can be used for all areas.

Ref. No.	Part No.	Part Name & Description	Remarks	Ref. No.	Part No.	Part Name & Description	Remarks
		INTEGRATED CIRCUIT(S)		Q903	UN4113TA	TRANSISTOR	
				Q904	UN4214TA	TRANSISTOR	
				Q905	2SA1309AIRTA	TRANSISTOR	
				Q1001	2SC3940AQSTA	TRANSISTOR	Δ
IC101	LA1832A	FM/AM IF AMP./AM OSC					
IC102	LC7218	PLL FREQ. SYNTHESIZER					
IC351	MC14052BCP	VIDEO SELECTOR					
IC401	NJU7312AL	INPUT SELECTOR					
IC402	UPC4570C	BUFFER AMP.		D101	MA4051MTA	DIODE	Δ
IC451	AN6558-FSG	PHONO EQ AMP.		D102	MA165	DIODE	
IC501	BA6218	MOTOR DRIVE		D351, 352	MA4056MTA	DIODE	Δ
IC511	UPC4570C	PHONE AMP.		D353	MA165	DIODE	
IC551	UPC4570C	FLAT AMP.		D401	MA4075MTA	DIODE	Δ
IC601	RSN3306A	POWER AMP. (FRONT)	Δ	D501	MA165	DIODE	
IC602	SV13204B	POWER AMP.	Δ	D553	MA165	DIODE	
IC901	LC8A012C5524	MICROCOMPUTER		D601, 602	SB3606501T	DIODE	
IC1001	LA2785	DOLBY PRO LOGIC CONTROL		D603	MA700	DIODE	
IC1002	LV1010N	DOLBY PRO LOGIC DRIVE		D604-606	MA165	DIODE	
IC1003	M5218AP	BUFFER AMP		D608	MA165	DIODE	
		TRANSISTOR(S)		D654, 655	MA165	DIODE	
				D656	MA4047MTA	DIODE	
				D657	MA165	DIODE	
Q101	2SC2787L	TRANSISTOR		D701-704	P300D5002T	DIODE	Δ
Q103, 104	2SC2785FE	TRANSISTOR		D705, 706	MA4062MTA	DIODE	Δ
Q106	UN411FTA	TRANSISTOR		D707	MA4220MTA	DIODE	
Q107, 108	2SC3311ARSTA	TRANSISTOR		D708	MA4150M	DIODE	Δ
Q191-193	2SC3311ARSTA	TRANSISTOR	(E, EB, G, GN)	D721-724	P300DLF	DIODE	Δ
Q351	2SC3311AIRTA	TRANSISTOR		D751-754	1SR3520TB	DIODE	Δ
Q352, 353	2SA1309AIRTA	TRANSISTOR		D755	MA165	DIODE	
Q354	UN4213	TRANSISTOR		D756	MA4068M	DIODE	Δ
Q505, 506	2SC3327-A	TRANSISTOR		D771	MA165	DIODE	
Q551, 552	2SC3311AIRTA	TRANSISTOR		D772	MA4068M	DIODE	Δ
Q601-603	2SA1309AIRTA	TRANSISTOR		D773	MA165	DIODE	
Q651	2SA1309AIRTA	TRANSISTOR		D901	1SS291TA	DIODE	
Q652	2SC3311AIRTA	TRANSISTOR		D903	MA4056MTA	DIODE	Δ
Q681, 682	2SC3327-A	TRANSISTOR		D906	MA165	DIODE	(E, EB, G, GN)
Q701	2SD2374PQJ	TRANSISTOR	Δ	D907	MA165	DIODE	
Q703-705	2SC3311AIRTA	TRANSISTOR	Δ	D917	1SS291TA	DIODE	
Q706	2SC3940AQSTA	TRANSISTOR	Δ	D921	MA165	DIODE	
Q707	2SB621AQSTA	TRANSISTOR	Δ	D922	MA4039MTA	DIODE	Δ
Q708	2SB1548PQJ	TRANSISTOR	Δ	D923	MA165	DIODE	
Q751	UN421FTA	TRANSISTOR		D927, 928	MA165	DIODE	
Q752	2SC3940AQSTA	TRANSISTOR	Δ	D929	LN846RPH	L. E. D.	
Q771, 772	2SA1309AIRTA	TRANSISTOR		D1001	MA4100MTA	DIODE	Δ
Q773	2SB621AQSTA	TRANSISTOR	Δ			VARIABLE RESISTOR(S)	
Q774, 775	2SA1309AIRTA	TRANSISTOR					
Q901	UN4214TA	TRANSISTOR		VR501	RRY24B01B15A	VOLUME CONTROL	
Q902	2SA1309AIRTA	TRANSISTOR	Δ				

Ref. No.	Part No.	Part Name & Description	Remarks	Ref. No.	Part No.	Part Name & Description	Remarks
VR502	EVJ02QF02G15	BALANCE CONTROL					
VR511, 512	EVJYA1FA5C15	TONE CONTROL				FUSE (S)	
		COIL (S)					
L101	ELESNR68MA	COIL	(E, EB, G, GN)	F1	XBA2C16TBO	FUSE 250V 1.6A	(E, EB, EG, GN) Δ
L101	ELESN190MA	COIL	(EG)	F1	XBA2C31TBO	FUSE 250V 3.15A	(G) Δ
L103	ELEXTR47MA9	COIL		F2	XBA2C16TBO	FUSE 250V 1.6A	(G) Δ
L105, 106	RLQZB822KT-D	COIL				SWITCH(ES)	
L151	SLM1B10M-1M	COIL		S701	ESD26840A	VOLTAGE ADJ.	(G) Δ
L191	ELESNR68MA	COIL	(E, EB, G, GN)	S946	EVQ21405R	NUMERIC 5	
L191	ELESNR56MA	COIL	(EG)	S947	EVQ21405R	CENTER LEVEL (-)	
L501, 502	RLQZP1R0KT-Y	COIL		S948	EVQ21405R	TEST	
L601, 602	RLQYR73M	COIL		S949	EVQ21405R	NUMERIC 4	
L651, 652	RLQYR73M	COIL		S950	EVQ21405R	NUMERIC 6	
L701	SLQZ650MH49	COIL	(E, EB, EG, GN) Δ	S951	EVQ21405R	CENTER LEVEL (+)	
L751	ELEPK101KA	COIL		S952	EVQ21405R	NUMERIC 7	
L901	RLQZP101KT-Y	COIL		S953	EVQ21405R	REAR LEVEL (-)	
L1051	ELEPK101KA	COIL		S954	EVQ21405R	CD	
		TRANSFORMER (S)		S955	EVQ21405R	TUNER	
T701	RTP1P5E014-W	POWER TRANSFORMER (MAIN)	(E, EB, EG) Δ	S956	EVQ21405R	CENTER MODE	
T701	RTP1P5E015-W	POWER TRANSFORMER (MAIN)	(G) Δ	S957	EVQ21405R	NUMERIC 9	
T701	RTP1P5E016-W	POWER TRANSFORMER (MAIN)	(GN) Δ	S960	EVQ21405R	REAR LEVEL (+)	
T751	RTP115E003-V	POWER TRANSFORMER (SUB)	(E, EB, EG, GN) Δ	S961	EVQ21405R	NUMERIC 8	
T751	RTP115E005-V	POWER TRANSFORMER (SUB)	(G) Δ	S962	EVQ21405R	NUMERIC 0	
		COMPONENT COMBINATION (S)		S964	EVQ21405R	PHONO	
Z101	RLA6Z005M-T	COMPONENT COMBINATION	(E, EB, G, GN)	S966	EVQ21405R	MEMORY	
Z101	RLA2Z002M-T	COMPONENT COMBINATION	(EG)	S967	EVQ21405R	MUTING	
Z102	RL12Z006M-T	COMPONENT COMBINATION		S970	EVQ21405R	TAPE/DCC MONITOR	
Z891	RCDHC-278N	REMOTE SENSOR		S971	EVQ21405R	VCR2	
		FILTER (S) AND OSCILLATOR (S)		S972	EVQ21405R	VCR1	
CF201	RLFFETNGD01L	FILTER		S973	EVQ21405R	SP B	
CF202	RLFFETMGD01L	FILTER		S974	EVQ21405R	FM MODE	
CF901	EF0EC6004T4	FILTER		S975	EVQ21405R	BAND	
CF1051	EF0EC8004T4	FILTER		S976	EVQ21405R	DIRECT TUNING	
X101	RSXZ456KM07M	OSCILLATOR (456KHz)		S977	EVQ21405R	TUNING DOWN	
X102	RLFDGTD01I	OSCILLATOR (10.65MHz)		S978	EVQ21405R	POWER	
X103	SVQ49U722-S	OSCILLATOR (7.2MHz)		S980	EVQ21405R	3 STEREO	
		DISPLAY TUBE (S)		S981	EVQ21405R	SP A	
FL901	RSL0172-F	DISPLAY TUBE		S982	EVQ21405R	SURROUND	
		FM FRONT END PACK ASS'Y (S)		S983	EVQ21405R	NUMERIC 3	
Z120	ENV17290G1R	FM FRONT END		S984	EVQ21405R	NUMERIC 2	
				S985	EVQ21405R	NUMERIC 1	
				S987	EVQ21405R	TUNING UP	
						CONNECTOR (S) AND SOCKET (S)	
				CN101, 102	RJU057W007	SOCKET (7P)	
				CN401, 402	RJU057W007	SOCKET (7P)	
				CN501, 502	RJU003K008MI	SOCKET (8P)	
				CN601	RJU057W004	SOCKET (4P)	
				CN751	SJS305-1	CONNECTOR (3P)	(E, EB, EG, GN)

Ref. No.	Part No.	Part Name & Description	Remarks	Ref. No.	Part No.	Part Name & Description	Remarks
CN751	SJS702-1	CONNECTOR (7P)	(G)				
CN753-759	RJS1A1101T1	CONNECTOR (1P)				CABINET AND CHASSIS	
CN901-905	RJU003K008M1	SOCKET (8P)					
CP101, 102	RJT057W007-1	CONNECTOR (7P)		1	RHD30035-K1	SCREW	
CP401, 402	RJT057W007-1	CONNECTOR (7P)		2	RKM0219A-K	CABINET	
CP501, 502	RJT003K008-1	CONNECTOR (8P)		3	XTBS3+8JFZ1	SCREW	
CP601	RJT057W004-1	CONNECTOR (4P)		4	RGR0161E-E1	REAR PANEL	(E)
CP701A	RJT039W06T	CONNECTOR (6P)		4	RGR0161E-F1	REAR PANEL	(EB)
CP701B	RJT039W06T	CONNECTOR (6P)		4	RGR0161E-D	REAR PANEL	(EG)
CP901-905	RJT003K008-1	CONNECTOR (8P)		4	RGR0161F-A	REAR PANEL	(G)
		JACK (S)		4	RGR0161E-G1	REAR PANEL	(GN)
				5	RFKJAGX470PK	BOTTOM CASSIS ASS' Y	
				5-1	RKA0053-A	FOOT	
JK101	RJH4202M	ANT TERMINAL		6	RKQ0089	P. C. B. SUPPORT	
JK351	SJF3069-3N	TV MONITOR OUT/VIDEO		7	RMCO158	TRANSISTOR HOLDER	
JK401	SJF3068-7N	PHONO TERMINAL		8	RMNO249-1	FL HOLDER	
JK402	SJF3069N	CD IN/REC OUT TERMINAL		9	RGU0990A-K	POWER BUTTON	
JK403	SJF3069N	PLAY IN/VC2 IN TERMINAL		10	RGW0175-1K	BASS, TREBLE, BALANCE KNOB	
JK404	SJF3069N	VC1 OUT/VC1 IN TERMINAL		11	RHD26016	SCREW	
JK406	RJJ33TR01	REMOTE CONTROL OUT TERMINAL		12	RGW0163A-K	VOLUME KNOB	(E, EB, EG)
JK601	RJR0054	FRONT SPEAKER(A) TERMINAL		12	RGW0145-1K	VOLUME KNOB	(G, GN)
JK602	RJR0054	FRONT SPEAKER(B) TERMINAL		13	RHN90001	NUT	
JK603	RJR0054	REAR SPEAKER TERMINAL		14	RFKAGX470E	FRONT PANEL ASS' Y	(E, EB, EG)
JK604	SJF5201M-1	CENTER SPEAKER TERMINAL		14	RFKAGX470G	FRONT PANEL ASS' Y	(G, GN)
JK771	RJS1A7402-1	FAN MOTOR TERMINAL		14-1	RKW0318B-Q	TRANSPARENT PLATE	
JK791	SJS9236	AC INLET	(E, EB, EG) △	15	RGU0837C-K	SELECTOR BUTTON	
JK791	SJSD16	AC INLET	(GN) △	16	XTBS26+8J	SCREW	
JK793	SJS9231-1B	AC INLET	(G) △	17	SNE2123	GND TERMINAL	
HP601	RJJ63TS01	HEADPHONES JACK		18	XTB3+20JFZ	SCREW	
		GND PLATE (S)		19	XTB3+8JFZ	SCREW	
				20	XTW3+15T	SCREW	
				21	RFKEUG75PP-K	CONNECTOR ASS' Y(12P)	
E401	SNE1004-2	GND PLATE		22	RWJ1806110KK	FLAT CABLE (6P)	
E501	RSC0350	GND PLATE		23	SHR9814	CLAMPER	
E601	SNE1004-2	GND PLATE		24	XTWS3+8T	SCREW	
		FUSE HOLDER (S)		25	RMNO217	SUB2 P. C. B. HOLDER	
				26	REMO020-1	FAN UNIT	
FC701, 702	EYF52BC	FUSE HOLDER		26-1	MDN-4RB4MRC	MOTOR	
FC703, 704	EYF52BC	FUSE HOLDER	(G)	26-2	SHE232-1	FAN	
		RELAY (S)		26-3	RMQ0209-K	FAN CASE	
				26-4	RMQ0208-K	FAN CAP	
				26-5	SUS271	FAN TERMINAL	
				26-6	RMQ0212-K	FAN TERMINAL CAP	
RL601-603	RSY0013M-0	RELAY	△	27	SJS9231A	AC INLET COVER	(G)
RL751	RSY0019-0	RELAY	△	28	XTBS3+8JFZ1	SCREW	(E, EB, EG, GN)
				29	XTBS3+8JFZ1	SCREW	(G)

■ CABINET PARTS LOCATION

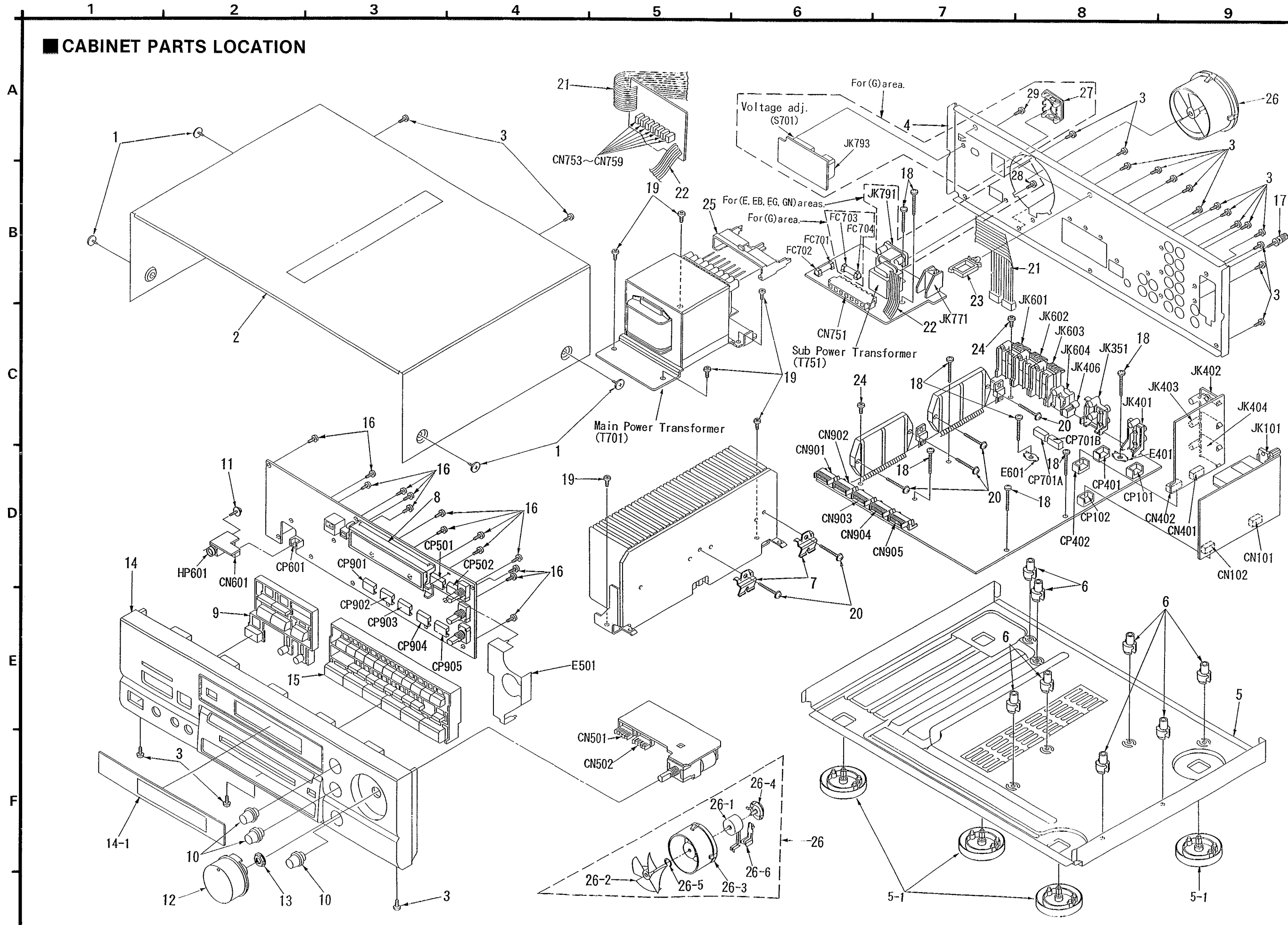

**RESISTORS AND CAPACITORS**

Notes : \* Capacity values are in microfarads (uF) unless specified otherwise, P=Pico-farads (pF) F=Farads (F)  
 \* Resistance values are in ohms, unless specified otherwise, 1K=1,000 (OHM), 1M=1,000k (OHM)

Ref. No.	Part No.	Values & Remarks	Ref. No.	Part No.	Values & Remarks	Ref. No.	Part No.	Values & Remarks
		RESISTORS						
R103	ERDS2TJ101	1/4W 100	R358	ERDS2TJ471	1/4W 470	R553, 554	ERDS2TJ104	1/4W 100K
R104	ERDS2TJ102	1/4W 1K	R359, 360	ERDS2TJ470	1/4W 47	R555	ERDS2TJ123	1/4W 12K
R105	ERDS2TJ471	1/4W 470	R361	ERDS2TJ471	1/4W 470	R556	ERDS2TJ103	1/4W 10K
R106	ERDS2TJ224T	1/4W 220K	R362	ERDS2TJ470	1/4W 47	R557	ERDS2TJ122	1/4W 1.2K
R107	ERDS2TJ471	1/4W 470	R363	ERDS2TJ332	1/4W 3.3K	R558	ERDS2TJ152	1/4W 1.5K
R110	ERDS2TJ102	1/4W 1K	R364	ERDS2TJ561	1/4W 560	R559, 560	ERDS2TJ104	1/4W 100K
R112	ERDS2TJ104	1/4W 100K	R365	ERDS2TJ332	1/4W 3.3K	R561	ERDS2TJ332	1/4W 3.3K
R113	ERDS2TJ103	1/4W 10K	R366	ERDS2TJ104	1/4W 100K	R562	ERDS2TJ272T	1/4W 2.7K
R114	ERDS2TJ562	1/4W 5.6K	R369, 370	ERDS1FVJ271T	1/2W 270 Δ	R565, 566	ERDS2TJ102	1/4W 1K
R115	ERDS2TJ561	1/4W 560	R401, 402	ERDS2TJ102	1/4W 1K	R567	ERDS2TJ474	1/4W 470K
R116	ERDS2TJ102	1/4W 1K	R405-416	ERDS2TJ102	1/4W 1K	R570	ERDS2TJ103	1/4W 10K
R117	ERDS2TJ473	1/4W 47K	R417, 418	ERDS2TJ473	1/4W 47K	R571	ERDS2TJ332	1/4W 3.3K
R118	ERDS2TJ562	1/4W 5.6K	R419-422	ERDS2TJ104	1/4W 100K	R575	ERDS2TJ102	1/4W 1K
R119	ERDS2TJ183T	1/4W 18K	R423, 424	ERDS2TJ102	1/4W 1K	R601, 602	ERDS2TJ102	1/4W 1K
R120	ERDS2TJ473	1/4W 47K	R425-427	ERDS2TJ103	1/4W 10K	R603, 604	ERDS2TJ563	1/4W 56K
R121	ERDS2TJ332	1/4W 3.3K	R440	ERDS1FVJ820T	1/2W 82 Δ	R605, 606	ERDS2TJ182	1/4W 1.8K
R122	ERDS2TJ272T	1/4W 2.7K	R441, 442	ERDS2TJ473	1/4W 47K	R607, 608	ERDS2TJ563	1/4W 56K
R124	ERDS2TJ271	1/4W 270	R443	ERDS2TJ330	1/4W 33	R609, 610	ERDS2TJ470	1/4W 47
R125, 126	ERDS2TJ472	1/4W 4.7K	R451, 452	ERDS2TJ224T	1/4W 220K	R611, 612	ERDS1FVJ100T	1/2W 10 Δ
R127	ERDS2TJ103	1/4W 10K	R453, 454	ERDS2TJ391	1/4W 390	R613, 614	ERDS2TJ102	1/4W 1K
R128	ERDS2TJ820	1/4W 82	R455, 456	ERDS2TJ563	1/4W 56K	R615	ERDS2TJ184T	1/4W 180K
R129	ERDS2TJ473	1/4W 47K	R457, 458	ERDS2TJ271	1/4W 270	R616	ERDS2TJ154	1/4W 150K
R130, 131	ERDS2TJ102	1/4W 1K	R459, 460	ERDS2TJ680T	1/4W 68	R617, 618	ERDS2TJ473	1/4W 47K
R132	ERDS2TJ103	1/4W 10K	R461, 462	ERDS2TJ184T	1/4W 180K	R619	ERDS2TJ223	1/4W 22K
R133-137	ERDS2TJ102	1/4W 1K	R463, 464	ERDS2TJ123	1/4W 12K	R620	ERD25FJ220	1/4W 22 Δ
R139, 140	ERDS2TJ272T	1/4W 2.7K	R465, 466	ERDS2TJ563	1/4W 56K	R621	ERDS2TJ183T	1/4W 18K
R141, 142	ERDS2TJ102	1/4W 1K	R467-470	ERDS2TJ102	1/4W 1K	R622	ERDS2TJ124T	1/4W 120K
R143, 144	ERDS2TJ222	1/4W 2.2K	R501, 502	ERDS2TJ222	1/4W 2.2K	R623	ERDS2TJ684	1/4W 680K
R145, 146	ERDS2TJ102	1/4W 1K E, EB, G, GN	R508	ERDS1FVJ2R2T	1/2W 2.2 Δ	R624, 625	ERDS2TJ154	1/4W 150K E, EB, EG
R145, 146	ERDS2TJ561	1/4W 560 EG	R511, 512	ERDS2TJ471	1/4W 470	R624, 625	ERDS2TJ563	1/4W 56K G, GN
R147, 148	ERDS2TJ474	1/4W 470K	R513-516	ERDS2TJ474	1/4W 470K	R626, 627	ERD25FVJ180T	1/4W 18 Δ
R149	ERDS2TJ680T	1/4W 68	R517, 518	ERDS2TJ332	1/4W 3.3K	R628-630	ERDS2TJ223	1/4W 22K
R171, 172	ERDS2TJ102	1/4W 1K	R519, 520	ERDS2TJ222	1/4W 2.2K	R631, 632	ERDS2TJ103	1/4W 10K
R173	ERDS2TJ471	1/4W 470	R521, 522	ERDS2TJ223	1/4W 22K	R633, 634	ERDS2TJ102	1/4W 1K
R175	ERDS2TJ102	1/4W 1K	R523, 524	ERDS2TJ392T	1/4W 3.9K	R635, 636	ERDS1FVJ561T	1/2W 560 Δ
R176	ERDS2TJ391	1/4W 390	R525, 526	ERDS2TJ222	1/4W 2.2K	R637-640	ERGISJ101E	1W 100
R191	ERDS2TJ103	1/4W 10K E, EB, G, GN	R527, 528	ERDS2TJ122	1/4W 1.2K	R641	ERDS2TJ684	1/4W 680K
R192	ERDS2TJ122	1/4W 1.2K E, EB, G, GN	R529, 530	ERDS2TJ273	1/4W 27K	R642	ERDS2TJ472	1/4W 4.7K
R193	ERDS2TJ182	1/4W 1.8K E, EB, G, GN	R531, 532	ERDS2TJ102	1/4W 1K	R643	ERDS2TJ103	1/4W 10K
R194	ERDS2TJ122	1/4W 1.2K E, EB, G, GN	R533, 534	ERDS2TJ103	1/4W 10K	R647, 648	ERDS2TJ221	1/4W 220
R195	ERDS2TJ222	1/4W 2.2K E, EB, G, GN	R535, 536	ERDS2TJ682T	1/4W 6.8K E, EB, EG	R651, 652	ERDS2TJ102	1/4W 1K
R351, 352	ERDS2TJ471	1/4W 470	R535, 536	ERDS2TJ392T	1/4W 3.9K G, GN	R653, 654	ERDS2TJ563	1/4W 56K
R354	ERDS2TJ472	1/4W 4.7K	R537, 538	ERDS2TJ392T	1/4W 3.9K E, EB, EG	R655, 656	ERDS2TJ182	1/4W 1.8K
R355	ERDS2TJ470	1/4W 47	R537, 538	ERDS2TJ472	1/4W 4.7K G, GN	R657, 658	ERDS2TJ563	1/4W 56K
R356	ERDS2TJ152	1/4W 1.5K	R543, 544	ERDS2TJ102	1/4W 1K	R659, 660	ERDS2TJ470	1/4W 47
R357	ERDS2TJ470	1/4W 47	R545	ERDS2TJ824	1/4W 820K	R661, 662	ERDS1FVJ100T	1/2W 10 Δ
			R546	ERDS2TJ332	1/4W 3.3K	R665	ERDS2TJ563	1/4W 56K
			R548	ERDS2TJ822	1/4W 8.2K	R666	ERDS2TJ104	1/4W 100K
			R551, 552	ERDS2TJ102	1/4W 1K	R667	ERD25FJ101	1/4W 100 Δ

Ref. No.	Part No.	Values & Remarks	Ref. No.	Part No.	Values & Remarks	Ref. No.	Part No.	Values & Remarks
R668	ERDS2TJ154	1/4W 150K	R921	ERDS2EJ121	1/4W 120	R1055, 1056	ERDS2TJ473	1/4W 47K
R669	ERDS2TJ223	1/4W 22K	R922	ERDS2TJ472	1/4W 4.7K	R1061	ERDS2TJ222	1/4W 2.2K
R670	ERD25FJ470	1/4W 47 Δ	R923	ERDS2TJ102	1/4W 1K	R1071, 1072	ERDS2TJ222	1/4W 2.2K
R671	ERDS2TJ103	1/4W 10K	R926	ERDS2TJ122	1/4W 1.2K	R1073, 1074	ERDS2TJ332	1/4W 3.3K E, EB, EG
R673	ERDS2TJ684	1/4W 680K	R927	ERDS2TJ181T	1/4W 180	R1073, 1074	ERDS2TJ682T	1/4W 6.8K G, GN
R674	ERDS2TJ473	1/4W 47K	R928	ERDS2TJ222	1/4W 2.2K	R1075, 1076	ERDS2TJ473	1/4W 47K
R676	ERDS2TJ223	1/4W 22K	R929	ERDS2TJ562	1/4W 5.6K	R1201, 1202	ERDS2TJ102	1/4W 1K
R677	ERDS2TJ103	1/4W 10K	R930, 931	ERDS2TJ101	1/4W 100	R1204, 1205	ERDS2TJ102	1/4W 1K
R678	ERDS1FVJ561T	1/2W 560 Δ	R946-949	ERDS2TJ103	1/4W 10K	R1207-1216	ERDS2TJ102	1/4W 1K
R679	ERDS2TJ222	1/4W 2.2K	R950	ERDS2TJ102	1/4W 1K			CAPACITORS
R680	ERDS2TJ333	1/4W 33K	R951	ERDS2TJ122	1/4W 1.2K			
R681-694	ERDS2TJ270T	1/4W 27	R952	ERDS2TJ152	1/4W 1.5K	C101	ECBT1C103NS5	16V 0.01U
R695, 696	ERDS2TJ102	1/4W 1K	R953	ERDS2TJ182	1/4W 1.8K	C103	ECBT1C103NS5	16V 0.01U
R697, 698	ERDS2TJ221	1/4W 220	R954	ERDS2TJ222	1/4W 2.2K	C104	ECBT1H102KB5	50V 1000P
R699	ERDS2TJ332	1/4W 3.3K	R955	ERDS2TJ332	1/4W 3.3K	C105	ECBT1H470J5	50V 47P
R703, 704	ERDS1FVJ3R9T	1/2W 3.9 Δ	R956	ERDS2TJ472	1/4W 4.7K	C106	ECBT1C103NS5	16V 0.01U
R705	ERDS2TJ472	1/4W 4.7K	R957	ERDS2TJ682T	1/4W 6.8K	C107	ECBT1H473ZF5	50V 0.047U
R706	ERDS2TJ102	1/4W 1K	R960	ERDS2TJ102	1/4W 1K	C108	ECBT1H100JC5	50V 10P E, EB, G, GN
R709	ERD25FVJ221T	1/4W 220 Δ	R961	ERDS2TJ122	1/4W 1.2K	C108	ECBT1H82KC5	50V 8.2P EG
R712	ERDS2TJ472	1/4W 4.7K	R962	ERDS2TJ152	1/4W 1.5K	C109, 110	ECBT1C103NS5	16V 0.01U
R713, 714	ERDS2TJ185T	1/4W 1.5	R963	ERDS2TJ182	1/4W 1.8K	C111	ECEALEKA4R7B	25V 4.7U
R715	ERDS2TJ752T	1/4W 7.5K	R964	ERDS2TJ222	1/4W 2.2K	C112	ECBT1C103NS5	16V 0.01U
R716	ERDS2TJ682T	1/4W 6.8K	R965	ERDS2TJ332	1/4W 3.3K	C113	ECBT1H102KB5	50V 1000P
R717	ERDS1FVJ220T	1/2W 22 Δ	R966	ERDS2TJ472	1/4W 4.7K	C114	ECEA1HKA3R3B	50V 3.3U
R718	ERDS2TJ182	1/4W 1.8K	R967	ERDS2TJ682T	1/4W 6.8K	C115	ECEA1EKA4R7B	25V 4.7U
R721	ERDS1FVJ4R7T	1/2W 4.7 Δ	R970	ERDS2TJ102	1/4W 1K	C116	ECBT1C822MS5	16V 8200P
R722	ERD25FJ101	1/4W 100 Δ	R971	ERDS2TJ122	1/4W 1.2K	C117	ECQB1H471JF3	50V 470P
R723	ERDS2TJ472	1/4W 4.7K	R972	ERDS2TJ152	1/4W 1.5K	C118, 119	ECQB1H103JF3	50V 0.01U
R724	ERDS1FVJ6R8T	1/2W 6.8 Δ	R973	ERDS2TJ182	1/4W 1.8K	C120, 121	ECEA1HKA010B	50V 1U
R725	ERDS2TJ152	1/4W 1.5K	R974	ERDS2TJ222	1/4W 2.2K	C122	ECEA1HKA2R2B	50V 2.2U
R727	ERDS1FVJ4R7T	1/2W 4.7 E, EB, EG	R975	ERDS2TJ332	1/4W 3.3K	C123	ECEA1HKA010B	50V 1U
R727	ERDS1FVJ2R2T	1/2W 2.2 G, GN	R976	ERDS2TJ472	1/4W 4.7K	C124	ECBT1H102KB5	50V 1000P
R754	ERDS2TJ102	1/4W 1K	R977	ERDS2TJ682T	1/4W 6.8K	C125	ECBT1H150JC5	50V 15P
R772	ERDS2TJ104	1/4W 100K	R978	ERDS2TJ123	1/4W 12K	C126	ECBT1H104ZF5	50V 0.1U
R773	ERDS2TJ103	1/4W 10K	R980	ERDS2TJ102	1/4W 1K	C127	ECEA1CKA220B	16V 22U
R774	ERDS2TJ223	1/4W 22K	R981	ERDS2TJ122	1/4W 1.2K	C128	ECBT1C103NS5	16V 0.01U
R775	ERDS2TJ332	1/4W 3.3K	R982	ERDS2TJ152	1/4W 1.5K	C129, 130	ECEA0JKA101B	6.3V 100U
R776	ERDS1FVJ220T	1/2W 22 Δ	R983	ERDS2TJ182	1/4W 1.8K	C131	ECBT1C103NS5	16V 0.01U
R777	ERDS2TJ220T	1/4W 22	R984	ERDS2TJ222	1/4W 2.2K	C132	ECBT1H102KB5	50V 1000P
R778	ERDS2TJ222	1/4W 2.2K	R985	ERDS2TJ332	1/4W 3.3K	C133	ECBT1H150JC5	50V 15P
R779	ERDS2TJ103	1/4W 10K	R986	ERDS2TJ472	1/4W 4.7K	C134	ECBT1H180JC5	50V 18P
R780, 781	ERDS2TJ333	1/4W 33K	R987	ERDS2TJ682T	1/4W 6.8K	C135, 136	ECBT1C103KS5	16V 0.01U
R782	ERDS2TJ153	1/4W 15K	R991	ERDS2TJ103	1/4W 10K	C137, 138	ECBT1H561KB5	50V 560P
R783	ERDS2TJ103	1/4W 10K	R1001, 1002	ERDS2TJ223	1/4W 22K	C139, 140	ECQB1H682JF3	50V 6800P
R784	ERDS2TJ335T	1/4W 3.3M	R1003, 1004	ERDS2TJ102	1/4W 1K	C141-144	ECEA1HKA010B	50V 1U
R791-796	ERDS2TJ223	1/4W 22						



Ref. No.	Part No.	Values & Remarks	Ref. No.	Part No.	Values & Remarks	Ref. No.	Part No.	Values & Remarks
C173	ECEA1CKA220B	16V 22U	C561, 562	ECEA1HKA3R3B	50V 3. 3U	C771	ECEA1HKA2R2B	50V 2. 2U
C174	ECEA1CKA101B	16V 100U	C563	ECEA1HKN010B	50V 1U	C772	ECEA1CKA100B	16V 10U
C175, 176	ECBT1C103NS5	16V 0. 01U	C601, 602	ECEA1HKN3R3B	50V 3. 3U	C773	ECBT1E223ZF	25V 0. 022U
C181	ECBT1H471KB5	50V 470P	C603, 604	ECBT1H181KB5	50V 180P	C774	RCE0JKA221BV	6. 3V 220U
C196	ECBT1H102KB5	50V 1000P	C605, 606	RCE1JU220BV	63V 22U	C891	ECFR1E392KR	25V 3900P
C351, 352	ECEAOJKA101B	6. 3V 100U	C607, 608	ECCR1H100K5	50V 10P	C901	ECAOJM102B	6. 3V 1000U
C353	ECEA1CKA100B	16V 10U	C609, 610	ECBT1H221KB5	50V 220P	C902, 903	ECBT1E103ZF	25V 0. 01U
C401, 402	ECEA1VKA4R7B	35V 4. 7U	C611, 612	ECQV1H473JM3	50V 0. 047U	C904	ECAOJM471B	6. 3V 470U
C403, 404	ECBT1E103ZF	25V 0. 01U	C613, 614	ECBA1H681KB5	50V 680P	C906	ECEAOJKA101B	6. 3V 100U
C405, 406	ECBT1H101KB5	50V 100P	C615	ECA1HM470B	50V 47U	C908	ECBT1E103ZF	25V 0. 01U
C409, 410	ECEA1CKA220B	16V 22U	C616	ECEA2AU100	100V 10U	C909-912	RCE1JU220BV	63V 22U
C411, 412	ECBT1H101KB5	50V 100P	C617	RCE1JU220BV	63V 22U	C913, 914	ECEA1VKA100B	35V 10U
C413, 414	ECEA1CKA100B	16V 10U	C618	ECEA2AN2R2SB	100V 2. 2U	C916	ECEA1HKA010B	50V 1U
C415, 416	ECBT1E103ZF	25V 0. 01U	C621, 622	ECEA2AU100	100V 10U	C919	ECBT1E103ZF	25V 0. 01U
C417, 418	ECBT1H101KB5	50V 100P	C631-634	ECKT1H223ZF	50V 0. 022U	C920	ECEA1HKA010B	50V 1U
C419-422	ECBT1H331KB5	50V 330P	C635, 636	ECKR1H03ZF5	50V 0. 01U	C921-928	ECBT1H331KB5	50V 330P
C423-426	ECBT1H101KB5	50V 100P	C637	ECKT1H223ZF	50V 0. 022U	C929, 930	ECBT1H101KB5	50V 100P
C427, 428	ECBT1H221KB5	50V 220P	C651, 652	ECEA1HKN3R3B	50V 3. 3U	C935	ECEAOJKA101B	6. 3V 100U
C431, 432	ECEA1CKA100B	16V 10U	C653, 654	ECBA1H681KB5	50V 680P	C936	ECBT1E103ZF	25V 0. 01U
C440	ECBT1E103ZF	25V 0. 01U	C655, 656	ECEA1CKA220B	16V 22U	C937-939	ECBT1H101KB5	50V 100P
C451, 452	ECEA1VKA4R7B	35V 4. 7U	C657, 658	ECCR1H100K5	50V 10P	C944	ECBT1H101KB5	50V 100P
C453, 454	ECBT1H100JC5	50V 10P	C659, 660	ECBT1H151KB5	50V 150P	C945	ECBT0J223MS5	6. 3V 0. 022U
C455, 456	ECBT1H102KB5	50V 1000P	C661, 662	ECQV1H473JM3	50V 0. 047U	C1001, 1002	ECEA1HKA010B	50V 1U
C457, 458	ECEA1AKA330B	10V 33U	C665	ECA1HM470B	50V 47U	C1003, 1004	ECEA1HKA3R3B	50V 3. 3U
C459, 460	ECFR1E223KR	25V 0. 022U	C667	RCE1JU220BV	63V 22U	C1005	ECEA1HKA010B	50V 1U
C461, 462	ECFR1E682KR	25V 6800P	C668	ECEA2AU100	100V 10U	C1007	ECFR1E223KR	25V 0. 022U
C463, 464	ECEA1VKA4R7B	35V 4. 7U	C669	ECEA2AN2R2SB	100V 2. 2U	C1008	ECFR1E473KR	25V 0. 047U
C465, 466	ECBT1E103ZF	25V 0. 01U	C681, 682	ECEA1HN100SB	50V 10U	C1009	RCE0JKA221BV	6. 3V 220U
C469, 470	ECBT1H181KB5	50V 180P	C683, 684	ECBT1C332KR5	16V 3300P	C1010-1013	ECEA1CKA100B	16V 10U
C503, 504	ECEAOJKA101B	6. 3V 100U	C685	ECBT1E103ZF	25V 0. 01U	C1014	RCE0JKA221BV	6. 3V 220U
C505, 506	ECFR1E104KR	25V 0. 1U	C691	ECKT1H101KB	50V 100P	C1015, 1016	ECQV1H104JM3	50V 0. 1U
C511, 512	ECEA1HKA3R3B	50V 3. 3U	C701	ECBT1E103ZF	25V 0. 01U	C1017	ECEA1HKA47B	50V 0. 47U
C513, 514	ECBT1H150J5	50V 15P	C702	ECQE2104KF3	250V 0. 1U	C1018	ECEA1VKA4R7B	35V 4. 7U
C515, 516	ECBT1H221KB5	50V 220P	C703, 704	ECOS1JP682CZ	63V 6800U E, EB, EG Δ	C1019	ECEA1HKA47B	50V 0. 47U
C517, 518	ECBT1H330J5	50V 33P	C703, 704	ECE575V752UX	75V 7500U G, GN Δ	C1020	ECEA1VKA4R7B	35V 4. 7U
C519, 520	ECEA1VKA4R7B	35V 4. 7U	C705, 706	ECA1HM332B	50V 3300U Δ	C1021	ECEA1HKAR15B	50V 0. 15U
C521	ECEA1CKA220B	16V 22U	C707	RCE1VM101BV	35V 100U	C1022	ECEA1HKA3R3B	50V 3. 3U
C522	ECEA1CKA100B	16V 10U	C708	ECKR1H103ZF5	50V 0. 01U	C1023, 1024	ECQV1H154JM3	50V 0. 15U
C523, 524	ECFR1E123KR	25V 0. 012U	C709	ECEA1CKA330B	16V 33U	C1025	ECEA1HKA3R3B	50V 3. 3U
C525, 526	ECQV1H683JM3	50V 0. 068U	C710	ECBT1E103ZF	25V 0. 01U	C1026	ECEA1HKAR15B	50V 0. 15U
C527, 528	ECBT1C562KR5	16V 5600P	C711	ECKR1H103ZF5	50V 0. 01U	C1027	ECEA1VKA4R7B	35V 4. 7U
C529, 530	ECQB1H273JF3	50V 0. 027U	C712	ECEA1HKA100B	50V 10U	C1028	ECEA1HKAR47B	50V 0. 47U
C531, 532	ECBT1E103ZF	25V 0. 01U	C713	ECKR1H103ZF5	50V 0. 01U	C1029	ECEA1VKA4R7B	35V 4. 7U
C533	ECEA1CKA100B	16V 10U	C714	ECEA1CKA470B	16V 47U	C1030	ECEA1HKAR47B	50V 0. 47U
C534	ECEA1VKA4R7B	35V 4. 7U	C721	ECQE2104KF3	250V 0. 1U	C1031, 1032	ECQV1H104JM3	50V 0. 1U
C536	ECEA1HKN010B	50V 1U	C751	ECKWNS102MBM	400V 1000P Δ	C1033	ECEA1CKA470B	16V 47U
C537, 538	ECEA1CKA100B	16V 10U	C752	ECKR1H103ZF5	50V 0. 01U	C1034	ECQV1H474JM3	50V 0. 47U
C551, 552	ECEA1HKA3R3B	50V 3. 3U	C753	ECA1EM102B	25V 1000U Δ	C1035	ECBA1H681KB5	50V 680P
C553, 554	ECBT1H101KB5	50V 100P	C754	ECBT1E103ZF	25V 0. 01U	C1036-1038	ECBT1H101KB5	50V 100P
C555, 556	ECBT1H221KB5	50V 220P	C755	ECEA1CKA470B	16V 47U	C1039	ECEA1CKA101B	16V 100U
C557, 558	ECBT1E103ZF	25V 0. 01U	C756	ECBT1H101KB5	50V 100P	C1040	ECEA1CKA100B	16V 10U
C559, 560	ECEA1CKA100B	16V 10U	C758	ECEA1AKA101B	10V 100U	C1041	ECBT1E103ZF	25V 0. 01U

Ref. No.	Part No.	Values & Remarks	Ref. No.	Part No.	Values & Remarks	Ref. No.	Part No.	Values & Remarks
C1051	ECEA1HKA2R2B	50V 2.2U	C1057	ECFR1E152KR	25V 1500P	C1065	ECBA1H681KB5	50V 680P
C1052	ECEA1HKA010B	50V 1U	C1058	ECFR1E333KR	25V 0.033U	C1067, 1068	ECBT1C152KR5	16V 1500P
C1053	ECEA1HKA3R3B	50V 3.3U	C1059	ECEA1CKA101B	16V 100U	C1071, 1072	ECEA1HKA3R3B	50V 3.3U
C1054	RCE0JKA221BV	6.3V 220U	C1060	ECBT1E223ZF	25V 0.022U	C1073, 1074	ECEA1CKA100B	16V 10U
C1055	ECEA1HKA010B	50V 1U	C1062	ECBT1E223ZF	25V 0.022U			
C1056	ECFR1E333KR	25V 0.033U	C1063	ECEA1CKA101B	16V 100U			

## REPLACEMENT PARTS LIST

**Notes:** \*Important safety notice:

- Components identified by  $\Delta$  mark have special characteristics important for safety. Furthermore, special parts which have purposes of fire-retardant (resistors), high-quality sound (capacitors), low-noise (resistors), etc. are used. When replacing any of components, be sure to use only manufacturer's specified parts shown in the parts list.
- \*The parenthesized indications in the Remarks columns specify the areas. (Refer to the cover page for area.) Parts without these indications can be used for all areas.
- \*Remote Control Ass'y: Supply period for three years from termination of production.
- \*The "(SF)" mark denotes the standard part.

Ref. No.	Part No.	Part Name & Description	Remarks	Ref. No.	Part No.	Part Name & Description	Remarks
		PACKING MATERIAL		A2	RJA0019-2K	AC POWER SUPPLY CORD	(E, EG, G) $\Delta$ (SF)
				A2	VJA0733	AC POWER SUPPLY CORD	(EB) $\Delta$ (SF)
				A2	RJA0036-K	AC POWER SUPPLY CORD	(GN) $\Delta$ (SF)
P1	RPG2081	PACKING CASE	(E, EG, G, GN)	A3	RSA0007	FM INDOOR ANTENNA	
P1	RPG2082	PACKING CASE	(EB)	A4	RSA0010	AM LOOP ANTENNA SET	
P2	RPND752	CUSHION		A4-1	RMND244	AM ANTENNA HOLDER	
P3	RPQ0164	PAD		A4-2	XTN3+10AFZ	SCREW	
P4	RPH0032	MIRROR SHEET	(EB, GN)	A5	RQCB0169	SERVICENTER LIST	
P5	XZB60X65A01Z	PROTECTION BAG (UNIT)		A6	RQA0013	WARRANTY CARD	(E, EB, EG)
P6	RPF0134	PROTECTION BAG (F. B.)		A6	RQX7433ZA	WARRANTY CARD	(GN)
		ACCESSORIES		A7	RAK-SA114XH	REMOTE CONTROL TRANSMITTER	
				A7-1	RKN0057-K	BATTERY COVER	FOR R/C TRANSMITTER
A1	RFKSAGX470E	INSTRUCTION MANUAL ASS'Y	(E)	A8	SJP9009	ATTACHMENT PLUG	(EB) $\Delta$
A1	RFKSAGX470EB	INSTRUCTION MANUAL ASS'Y	(EB, GN)	A9	RFE0014	ANTENNA PLUG	(G, GN)
A1	RFKSAGX470EG	INSTRUCTION MANUAL ASS'Y	(EG)	A10	RQLA0134	VOLTAGE CAUTION LABEL	(G)
A1	RFKSAGX470G	INSTRUCTION MANUAL ASS'Y	(G)	A11	SJP5213-1	POWER PLUG ADAPTOR	(G) $\Delta$

## PACKAGING

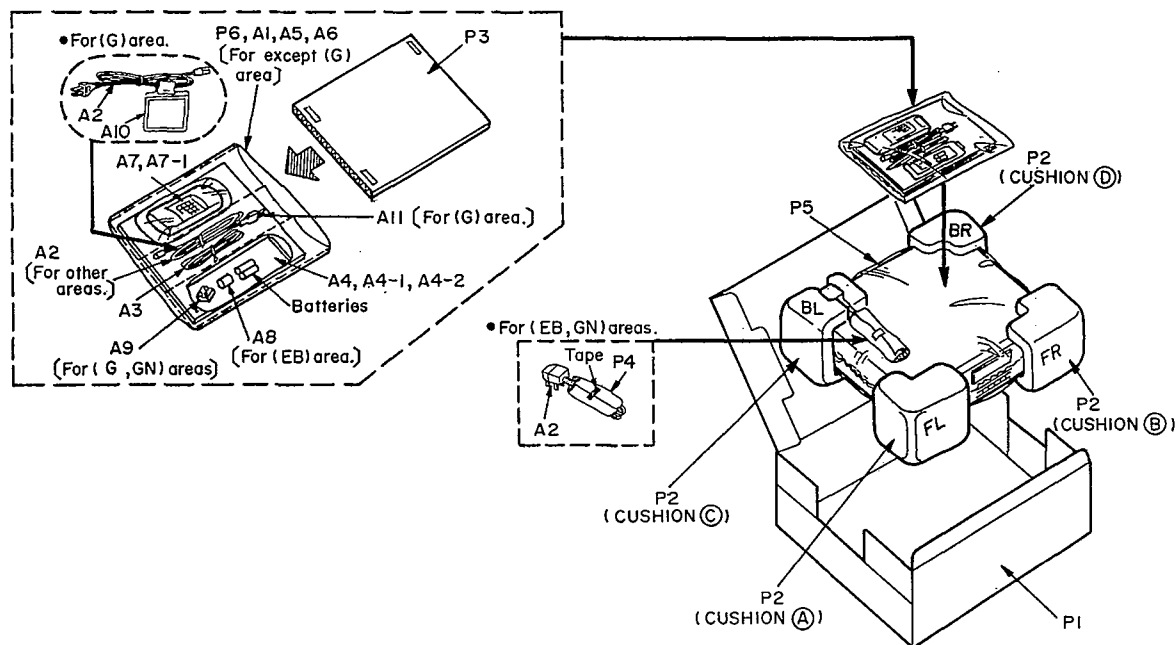

( CUSHION (A), (B), (C), (D) : RPND752 )

X.

■ WIRING CONNECTION DIAGRAM

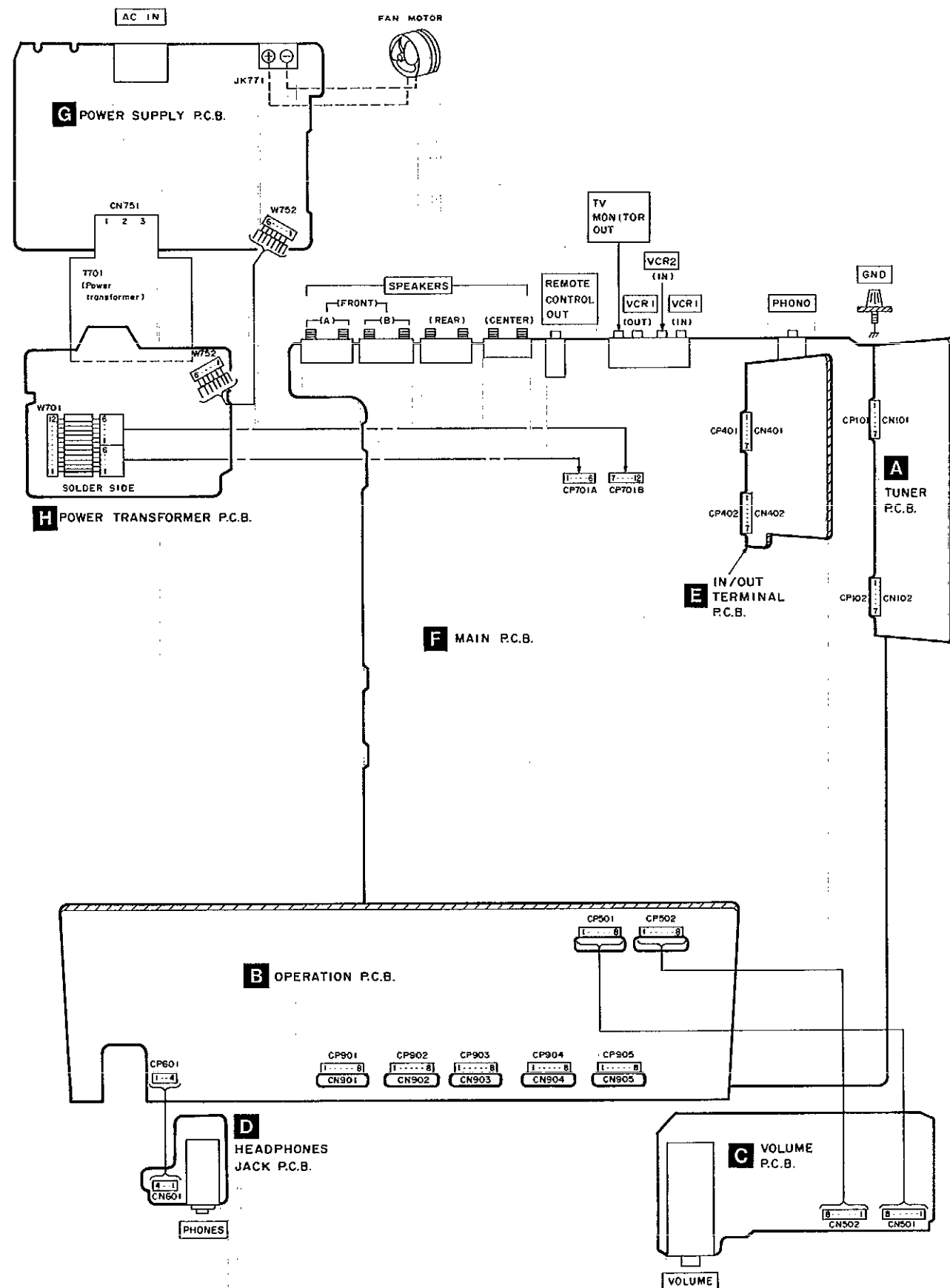

■ TERMINAL FUNCTION OF IC

• IC901 (LC8A012C5524): Microcomputer

Pin No.	Mark	I/O Division	Function
1	SPA	O	Speaker select control terminal
2	SPB	O	Speaker select control terminal
3	ST1	O	Level shift control terminal
4	NC	—	Not used, open
5	RELAY	O	Relay control terminal
6	AF MUTE	O	Muting control terminal
7	LIMIT	O	Muting control (-20dB) terminal
8	DG1	O	Digit signal of FL display
15	DG8	O	Digit signal of FL display
16	S13	O	Segment signal of FL display
17	VDD	I	Power supply terminal
18	VPP	I	Power supply terminal of FL display
19	S12	O	Segment signal of FL display
30	S1	O	Segment signal of FL display
31	FWD	O	Rotation control terminal of volume motor
32	REV	O	Rotation control terminal of volume motor
33	IN1	—	Not used, connected to resistor
34	FMST	I	Stereo signal detect terminal
35	SD	I	Received signal detect terminal
36	IFDATAIN	I	Serial data signal
37	LOUDNESS	—	Not used, open
38	ST3	O	Level shift control terminal
39	VIDEO	O	Video selector control terminal
40	CE	O	Chip enable terminal

Pin No.	Mark	I/O Division	Function
41	DATA1	O	Serial data signal
42	OVER LOAD	I	Over load detect terminal
43	CK1	O	Serial clock signal
44	DATA2	O	Serial data signal
45	ST2	O	Level shift control terminal
46	CK2	O	Serial clock signal
47	5-6	O	Remote control terminal
48	SURR PASS	O	Level shift control terminal
49	NC	—	Test terminal
50	RESET	I	Reset detect terminal
51	XT1	I	Not used, connected to power supply
52	XT2	—	Not used, open
53	VSS	—	GND terminal
54	CF1	I	Crystal oscillator
55	CF2	O	Terminal (6 MHz)
56	VDD	I	Power supply terminal
57	KEY1	I	Key matrix detect terminal
60	KEY4	I	
61	STANDBY	I	Power detect terminal
62	ENCODE A	I	Not used, connected to power supply
63	ENCODE B	I	
64	REMOCON IN	I	Remote control terminal

■ REPLACEMENT PARTS LIST

Notes: \*Important safety notice:  
 Components identified by Δ mark have special characteristics important for safety. Furthermore, special parts which have purposes of fire-retardant (resistors), high-quality sound (capacitors), low-noise (resistors), etc. are used. When replacing any of components, be sure to use only manufacturer's specified parts shown in the parts list. \*The parenthesized indications in the Remarks columns specify the areas. (Refer to the cover page for area.) Parts without these indications can be used for all areas.

Ref. No.	Part No.	Part Name & Description	Remarks	Ref. No.	Part No.	Part Name & Description	Remarks
		INTEGRATED CIRCUIT(S)		Q903	UN4113TA	TRANSISTOR	
				Q904	UN4214TA	TRANSISTOR	
				Q905	2SA1309AIRTA	TRANSISTOR	
IC101	LA1832A	FM/AM IF AMP./AM OSC		Q1001	2SC3940AQSTA	TRANSISTOR	Δ
IC102	LC7218	PLL FREQ. SYNTHESIZER					
IC351	MC14052BCP	VIDEO SELECTOR				DIODE(S)	
IC401	NJU7312AL	INPUT SELECTOR					
IC402	UPC4570C	BUFFER AMP.		D101	MA4051MTA	DIODE	Δ
IC451	AN6558-FSG	PHONO EQ AMP.		D102	MA165	DIODE	
IC501	BA6218	MOTOR DRIVE		D351, 352	MA4056MTA	DIODE	Δ
IC511	UPC4570C	TRAMP.		D353	MA165	DIODE	
IC551	UPC4570C	FLAT AMP.		D401	MA4075MTA	DIODE	Δ
IC601	RSN3306A	POWER AMP. (FRONT)	Δ	D501	MA165	DIODE	
IC602	SV13204B	POWER AMP.	Δ	D553	MA165	DIODE	
IC901	LC8A012C5524	MICROCOMPUTER		D601, 602	SB3606501T	DIODE	
IC1001	LA2785	DOLBY PRO LOGIC CONTROL		D603	MA700	DIODE	
IC1002	LV1010N	DOLBY PRO LOGIC DRIVE		D604-606	MA165	DIODE	
IC1003	M5218AP	BUFFER AMP		D608	MA165	DIODE	
		TRANSISTOR(S)		D654, 655	MA165	DIODE	
				D656	MA4047MTA	DIODE	
				D657	MA165	DIODE	
Q101	2SC2787L	TRANSISTOR		D701-704	P300D5002T	DIODE	Δ
Q103, 104	2SC2785FE	TRANSISTOR		D705, 706	MA4062MTA	DIODE	Δ
Q106	UN411FTA	TRANSISTOR		D707	MA4220MTA	DIODE	
Q107, 108	2SC3311ARSTA	TRANSISTOR		D708	MA4150M	DIODE	Δ
Q191-193	2SC3311ARSTA	TRANSISTOR	(E, EB, G, GN)	D721-724	P300DLF	DIODE	Δ
Q351	2SC3311AIRTA	TRANSISTOR		D751-754	1SR3520TB	DIODE	Δ
Q352, 353	2SA1309AIRTA	TRANSISTOR		D755	MA165	DIODE	
Q354	UN4213	TRANSISTOR		D756	MA4068M	DIODE	Δ
Q505, 506	2SC3327-A	TRANSISTOR		D771	MA165	DIODE	
Q551, 552	2SC3311AIRTA	TRANSISTOR		D772	MA4068M	DIODE	Δ
Q601-603	2SA1309AIRTA	TRANSISTOR		D773	MA165	DIODE	
Q651	2SA1309AIRTA	TRANSISTOR		D901	1SS291TA	DIODE	
Q652	2SC3311AIRTA	TRANSISTOR		D903	MA4056MTA	DIODE	Δ
Q681, 682	2SC3327-A	TRANSISTOR		D906	MA165	DIODE	(E, EB, G, GN)
Q701	2SD2374PQJ	TRANSISTOR	Δ	D907	MA165	DIODE	
Q703-705	2SC3311AIRTA	TRANSISTOR	Δ	D917	1SS291TA	DIODE	
Q706	2SC3940AQSTA	TRANSISTOR	Δ	D921	MA165	DIODE	
Q707	2SB621AQSTA	TRANSISTOR	Δ	D922	MA4039MTA	DIODE	Δ
Q708	2SB1548PQJ	TRANSISTOR	Δ	D923	MA165	DIODE	
Q751	UN421FTA	TRANSISTOR		D927, 928	MA165	DIODE	
Q752	2SC3940AQSTA	TRANSISTOR	Δ	D929	LN846RPH	L. E. D.	
Q771, 772	2SA1309AIRTA	TRANSISTOR		D1001	MA4100MTA	DIODE	Δ
Q773	2SB621AQSTA	TRANSISTOR	Δ			VARIABLE RESISTOR(S)	
Q774, 775	2SA1309AIRTA	TRANSISTOR					
Q901	UN4214TA	TRANSISTOR		VR501	RRY24B01B15A	VOLUME CONTROL	
Q902	2SA1309AIRTA	TRANSISTOR	Δ				

Ref. No.	Part No.	Part Name & Description	Remarks	Ref. No.	Part No.	Part Name & Description	Remarks
VR502	EVJ02QF02G15	BALANCE CONTROL					
VR511, 512	EVJYA1FA5C15	TONE CONTROL				FUSE (S)	
		COIL (S)					
L101	ELESNR68MA	COIL	(E, EB, G, GN)	F1	XBA2C16TBO	FUSE 250V 1.6A	(E, EB, EG, GN) Δ
L101	ELESN190MA	COIL	(EG)	F1	XBA2C31TBO	FUSE 250V 3.15A	(G) Δ
L103	ELEXTR47MA9	COIL		F2	XBA2C16TBO	FUSE 250V 1.6A	(G) Δ
L105, 106	RLQZB822KT-D	COIL				SWITCH(ES)	
L151	SLM1B10M-1M	COIL		S701	ESD26840A	VOLTAGE ADJ.	(G) Δ
L191	ELESNR68MA	COIL	(E, EB, G, GN)	S946	EVQ21405R	NUMERIC 5	
L191	ELESNR56MA	COIL	(EG)	S947	EVQ21405R	CENTER LEVEL (-)	
L501, 502	RLQZP1R0KT-Y	COIL		S948	EVQ21405R	TEST	
L601, 602	RLQYR73M	COIL		S949	EVQ21405R	NUMERIC 4	
L651, 652	RLQYR73M	COIL		S950	EVQ21405R	NUMERIC 6	
L701	SLQZ650MH49	COIL	(E, EB, EG, GN) Δ	S951	EVQ21405R	CENTER LEVEL (+)	
L751	ELEPK101KA	COIL		S952	EVQ21405R	NUMERIC 7	
L901	RLQZP101KT-Y	COIL		S953	EVQ21405R	REAR LEVEL (-)	
L1051	ELEPK101KA	COIL		S954	EVQ21405R	CD	
		TRANSFORMER (S)		S955	EVQ21405R	TUNER	
T701	RTP1P5E014-W	POWER TRANSFORMER (MAIN)	(E, EB, EG) Δ	S956	EVQ21405R	CENTER MODE	
T701	RTP1P5E015-W	POWER TRANSFORMER (MAIN)	(G) Δ	S957	EVQ21405R	NUMERIC 9	
T701	RTP1P5E016-W	POWER TRANSFORMER (MAIN)	(GN) Δ	S960	EVQ21405R	REAR LEVEL (+)	
T751	RTP115E003-V	POWER TRANSFORMER (SUB)	(E, EB, EG, GN) Δ	S961	EVQ21405R	NUMERIC 8	
T751	RTP115E005-V	POWER TRANSFORMER (SUB)	(G) Δ	S962	EVQ21405R	NUMERIC 0	
		COMPONENT COMBINATION (S)		S964	EVQ21405R	PHONO	
Z101	RLA6Z005M-T	COMPONENT COMBINATION	(E, EB, G, GN)	S966	EVQ21405R	MEMORY	
Z101	RLA2Z002M-T	COMPONENT COMBINATION	(EG)	S967	EVQ21405R	MUTING	
Z102	RL12Z006M-T	COMPONENT COMBINATION		S970	EVQ21405R	TAPE/DCC MONITOR	
Z891	RCDHC-278N	REMOTE SENSOR		S971	EVQ21405R	VCR2	
		FILTER (S) AND OSCILLATOR (S)		S972	EVQ21405R	VCR1	
CF201	RLFFETNGD01L	FILTER		S973	EVQ21405R	SP B	
CF202	RLFFETMGD01L	FILTER		S974	EVQ21405R	FM MODE	
CF901	EFOEC6004T4	FILTER		S975	EVQ21405R	BAND	
CF1051	EFOEC8004T4	FILTER		S976	EVQ21405R	DIRECT TUNING	
X101	RSXZ456KM07M	OSCILLATOR (456KHz)		S977	EVQ21405R	TUNING DOWN	
X102	RLFDGTD01I	OSCILLATOR (10.65MHz)		S978	EVQ21405R	POWER	
X103	SVQ49U722-S	OSCILLATOR (7.2MHz)		S980	EVQ21405R	3 STEREO	
		DISPLAY TUBE (S)		S981	EVQ21405R	SP A	
FL901	RSL0172-F	DISPLAY TUBE		S982	EVQ21405R	SURROUND	
		FM FRONT END PACK ASS'Y (S)		S983	EVQ21405R	NUMERIC 3	
Z120	ENV17290G1R	FM FRONT END		S984	EVQ21405R	NUMERIC 2	
				S985	EVQ21405R	NUMERIC 1	
				S987	EVQ21405R	TUNING UP	
						CONNECTOR (S) AND SOCKET (S)	
				CN101, 102	RJU057W007	SOCKET (7P)	
				CN401, 402	RJU057W007	SOCKET (7P)	
				CN501, 502	RJU003K008MI	SOCKET (8P)	
				CN601	RJU057W004	SOCKET (4P)	
				CN751	SJS305-1	CONNECTOR (3P)	(E, EB, EG, GN)

Ref. No.	Part No.	Part Name & Description	Remarks	Ref. No.	Part No.	Part Name & Description	Remarks
CN751	SJS702-1	CONNECTOR (7P)	(G)				
CN753-759	RJS1A1101T1	CONNECTOR (1P)				CABINET AND CHASSIS	
CN901-905	RJU003K008M1	SOCKET (8P)					
CP101, 102	RJT057W007-1	CONNECTOR (7P)		1	RHD30035-K1	SCREW	
CP401, 402	RJT057W007-1	CONNECTOR (7P)		2	RKM0219A-K	CABINET	
CP501, 502	RJT003K008-1	CONNECTOR (8P)		3	XTBS3+8JFZ1	SCREW	
CP601	RJT057W004-1	CONNECTOR (4P)		4	RGR0161E-E1	REAR PANEL	(E)
CP701A	RJT039W06T	CONNECTOR (6P)		4	RGR0161E-F1	REAR PANEL	(EB)
CP701B	RJT039W06T	CONNECTOR (6P)		4	RGR0161E-D	REAR PANEL	(EG)
CP901-905	RJT003K008-1	CONNECTOR (8P)		4	RGR0161F-A	REAR PANEL	(G)
		JACK (S)		4	RGR0161E-G1	REAR PANEL	(GN)
				5	RFKJAGX470PK	BOTTOM CASSIS ASS' Y	
				5-1	RKA0053-A	FOOT	
JK101	RJH4202M	ANT TERMINAL		6	RKQ0089	P. C. B. SUPPORT	
JK351	SJF3069-3N	TV MONITOR OUT/VIDEO		7	RMCO158	TRANSISTOR HOLDER	
JK401	SJF3068-7N	PHONO TERMINAL		8	RMNO249-1	FL HOLDER	
JK402	SJF3069N	CD IN/REC OUT TERMINAL		9	RGU0990A-K	POWER BUTTON	
JK403	SJF3069N	PLAY IN/VC2 IN TERMINAL		10	RGW0175-1K	BASS, TREBLE, BALANCE KNOB	
JK404	SJF3069N	VC1 OUT/VC1 IN TERMINAL		11	RHD26016	SCREW	
JK406	RJJ33TR01	REMOTE CONTROL OUT TERMINAL		12	RGW0163A-K	VOLUME KNOB	(E, EB, EG)
JK601	RJR0054	FRONT SPEAKER(A) TERMINAL		12	RGW0145-1K	VOLUME KNOB	(G, GN)
JK602	RJR0054	FRONT SPEAKER(B) TERMINAL		13	RHN90001	NUT	
JK603	RJR0054	REAR SPEAKER TERMINAL		14	RFKGAGX470E	FRONT PANEL ASS' Y	(E, EB, EG)
JK604	SJF5201M-1	CENTER SPEAKER TERMINAL		14	RFKGAGX470G	FRONT PANEL ASS' Y	(G, GN)
JK771	RJS1A7402-1	FAN MOTOR TERMINAL		14-1	RKW0318B-Q	TRANSPARENT PLATE	
JK791	SJS9236	AC INLET	(E, EB, EG) △	15	RGU0837C-K	SELECTOR BUTTON	
JK791	SJSD16	AC INLET	(GN) △	16	XTBS26+8J	SCREW	
JK793	SJS9231-1B	AC INLET	(G) △	17	SNE2123	GND TERMINAL	
HP601	RJJ63TS01	HEADPHONES JACK		18	XTB3+20JFZ	SCREW	
		GND PLATE (S)		19	XTB3+8JFZ	SCREW	
				20	XTW3+15T	SCREW	
E401	SNE1004-2	GND PLATE		21	RFKEUG75PP-K	CONNECTOR ASS' Y(12P)	
E501	RSC0350	GND PLATE		22	RWJ1806110KK	FLAT CABLE (6P)	
E601	SNE1004-2	GND PLATE		23	SHR9814	CLAMPER	
		FUSE HOLDER (S)		24	XTWS3+8T	SCREW	
				25	RMNO217	SUB2 P. C. B. HOLDER	
FC701, 702	EYF52BC	FUSE HOLDER		26	REMO020-1	FAN UNIT	
FC703, 704	EYF52BC	FUSE HOLDER	(G)	26-1	MDN-4RB4MRC	MOTOR	
		RELAY (S)		26-2	SHE232-1	FAN	
				26-3	RMQ0209-K	FAN CASE	
RL601-603	RSY0013M-0	RELAY	△	26-4	RMQ0208-K	FAN CAP	
RL751	RSY0019-0	RELAY	△	26-5	SUS271	FAN TERMINAL	
				26-6	RMQ0212-K	FAN TERMINAL CAP	
				27	SJS9231A	AC INLET COVER	(G)
				28	XTBS3+8JFZ1	SCREW	(E, EB, EG, GN)
				29	XTBS3+8JFZ1	SCREW	(G)



**RESISTORS AND CAPACITORS**

Notes : \* Capacity values are in microfarads (uF) unless specified otherwise, P=Pico-farads (pF) F=Farads (F)  
 \* Resistance values are in ohms, unless specified otherwise, 1K=1,000 (OHM), 1M=1,000k (OHM)

Ref. No.	Part No.	Values & Remarks	Ref. No.	Part No.	Values & Remarks	Ref. No.	Part No.	Values & Remarks
		RESISTORS						
R103	ERDS2TJ101	1/4W 100	R358	ERDS2TJ471	1/4W 470	R553, 554	ERDS2TJ104	1/4W 100K
R104	ERDS2TJ102	1/4W 1K	R359, 360	ERDS2TJ470	1/4W 47	R555	ERDS2TJ123	1/4W 12K
R105	ERDS2TJ471	1/4W 470	R361	ERDS2TJ471	1/4W 470	R556	ERDS2TJ103	1/4W 10K
R106	ERDS2TJ224T	1/4W 220K	R362	ERDS2TJ470	1/4W 47	R557	ERDS2TJ122	1/4W 1.2K
R107	ERDS2TJ471	1/4W 470	R363	ERDS2TJ332	1/4W 3.3K	R558	ERDS2TJ152	1/4W 1.5K
R110	ERDS2TJ102	1/4W 1K	R364	ERDS2TJ561	1/4W 560	R559, 560	ERDS2TJ104	1/4W 100K
R112	ERDS2TJ104	1/4W 100K	R365	ERDS2TJ332	1/4W 3.3K	R561	ERDS2TJ332	1/4W 3.3K
R113	ERDS2TJ103	1/4W 10K	R366	ERDS2TJ104	1/4W 100K	R562	ERDS2TJ272T	1/4W 2.7K
R114	ERDS2TJ562	1/4W 5.6K	R369, 370	ERDS1FVJ271T	1/2W 270 Δ	R565, 566	ERDS2TJ102	1/4W 1K
R115	ERDS2TJ561	1/4W 560	R401, 402	ERDS2TJ102	1/4W 1K	R567	ERDS2TJ474	1/4W 470K
R116	ERDS2TJ102	1/4W 1K	R405-416	ERDS2TJ102	1/4W 1K	R570	ERDS2TJ103	1/4W 10K
R117	ERDS2TJ473	1/4W 47K	R417, 418	ERDS2TJ473	1/4W 47K	R571	ERDS2TJ332	1/4W 3.3K
R118	ERDS2TJ562	1/4W 5.6K	R419-422	ERDS2TJ104	1/4W 100K	R575	ERDS2TJ102	1/4W 1K
R119	ERDS2TJ183T	1/4W 18K	R423, 424	ERDS2TJ102	1/4W 1K	R601, 602	ERDS2TJ102	1/4W 1K
R120	ERDS2TJ473	1/4W 47K	R425-427	ERDS2TJ103	1/4W 10K	R603, 604	ERDS2TJ563	1/4W 56K
R121	ERDS2TJ332	1/4W 3.3K	R440	ERDS1FVJ820T	1/2W 82 Δ	R605, 606	ERDS2TJ182	1/4W 1.8K
R122	ERDS2TJ272T	1/4W 2.7K	R441, 442	ERDS2TJ473	1/4W 47K	R607, 608	ERDS2TJ563	1/4W 56K
R124	ERDS2TJ271	1/4W 270	R443	ERDS2TJ330	1/4W 33	R609, 610	ERDS2TJ470	1/4W 47
R125, 126	ERDS2TJ472	1/4W 4.7K	R451, 452	ERDS2TJ224T	1/4W 220K	R611, 612	ERDS1FVJ100T	1/2W 10 Δ
R127	ERDS2TJ103	1/4W 10K	R453, 454	ERDS2TJ391	1/4W 390	R613, 614	ERDS2TJ102	1/4W 1K
R128	ERDS2TJ820	1/4W 82	R455, 456	ERDS2TJ563	1/4W 56K	R615	ERDS2TJ184T	1/4W 180K
R129	ERDS2TJ473	1/4W 47K	R457, 458	ERDS2TJ271	1/4W 270	R616	ERDS2TJ154	1/4W 150K
R130, 131	ERDS2TJ102	1/4W 1K	R459, 460	ERDS2TJ680T	1/4W 68	R617, 618	ERDS2TJ473	1/4W 47K
R132	ERDS2TJ103	1/4W 10K	R461, 462	ERDS2TJ184T	1/4W 180K	R619	ERDS2TJ223	1/4W 22K
R133-137	ERDS2TJ102	1/4W 1K	R463, 464	ERDS2TJ123	1/4W 12K	R620	ERD25FJ220	1/4W 22 Δ
R139, 140	ERDS2TJ272T	1/4W 2.7K	R465, 466	ERDS2TJ563	1/4W 56K	R621	ERDS2TJ183T	1/4W 18K
R141, 142	ERDS2TJ102	1/4W 1K	R467-470	ERDS2TJ102	1/4W 1K	R622	ERDS2TJ124T	1/4W 120K
R143, 144	ERDS2TJ222	1/4W 2.2K	R501, 502	ERDS2TJ222	1/4W 2.2K	R623	ERDS2TJ684	1/4W 680K
R145, 146	ERDS2TJ102	1/4W 1K E, EB, G, GN	R508	ERDS1FVJ2R2T	1/2W 2.2 Δ	R624, 625	ERDS2TJ154	1/4W 150K E, EB, EG
R145, 146	ERDS2TJ561	1/4W 560 EG	R511, 512	ERDS2TJ471	1/4W 470	R624, 625	ERDS2TJ563	1/4W 56K G, GN
R147, 148	ERDS2TJ474	1/4W 470K	R513-516	ERDS2TJ474	1/4W 470K	R626, 627	ERD25FVJ180T	1/4W 18 Δ
R149	ERDS2TJ680T	1/4W 68	R517, 518	ERDS2TJ332	1/4W 3.3K	R628-630	ERDS2TJ223	1/4W 22K
R171, 172	ERDS2TJ102	1/4W 1K	R519, 520	ERDS2TJ222	1/4W 2.2K	R631, 632	ERDS2TJ103	1/4W 10K
R173	ERDS2TJ471	1/4W 470	R521, 522	ERDS2TJ223	1/4W 22K	R633, 634	ERDS2TJ102	1/4W 1K
R175	ERDS2TJ102	1/4W 1K	R523, 524	ERDS2TJ392T	1/4W 3.9K	R635, 636	ERDS1FVJ561T	1/2W 560 Δ
R176	ERDS2TJ391	1/4W 390	R525, 526	ERDS2TJ222	1/4W 2.2K	R637-640	ERGISJ101E	1W 100
R191	ERDS2TJ103	1/4W 10K E, EB, G, GN	R527, 528	ERDS2TJ122	1/4W 1.2K	R641	ERDS2TJ684	1/4W 680K
R192	ERDS2TJ122	1/4W 1.2K E, EB, G, GN	R529, 530	ERDS2TJ273	1/4W 27K	R642	ERDS2TJ472	1/4W 4.7K
R193	ERDS2TJ182	1/4W 1.8K E, EB, G, GN	R531, 532	ERDS2TJ102	1/4W 1K	R643	ERDS2TJ103	1/4W 10K
R194	ERDS2TJ122	1/4W 1.2K E, EB, G, GN	R533, 534	ERDS2TJ103	1/4W 10K	R647, 648	ERDS2TJ221	1/4W 220
R195	ERDS2TJ222	1/4W 2.2K E, EB, G, GN	R535, 536	ERDS2TJ682T	1/4W 6.8K E, EB, EG	R651, 652	ERDS2TJ102	1/4W 1K
R351, 352	ERDS2TJ471	1/4W 470	R535, 536	ERDS2TJ392T	1/4W 3.9K G, GN	R653, 654	ERDS2TJ563	1/4W 56K
R354	ERDS2TJ472	1/4W 4.7K	R537, 538	ERDS2TJ392T	1/4W 3.9K E, EB, EG	R655, 656	ERDS2TJ182	1/4W 1.8K
R355	ERDS2TJ470	1/4W 47	R537, 538	ERDS2TJ472	1/4W 4.7K G, GN	R657, 658	ERDS2TJ563	1/4W 56K
R356	ERDS2TJ152	1/4W 1.5K	R543, 544	ERDS2TJ102	1/4W 1K	R659, 660	ERDS2TJ470	1/4W 47
R357	ERDS2TJ470	1/4W 47	R545	ERDS2TJ824	1/4W 820K	R661, 662	ERDS1FVJ100T	1/2W 10 Δ
			R546	ERDS2TJ332	1/4W 3.3K	R665	ERDS2TJ563	1/4W 56K
			R548	ERDS2TJ822	1/4W 8.2K	R666	ERDS2TJ104	1/4W 100K
			R551, 552	ERDS2TJ102	1/4W 1K	R667	ERD25FJ101	1/4W 100 Δ

Ref. No.	Part No.	Values & Remarks	Ref. No.	Part No.	Values & Remarks	Ref. No.	Part No.	Values & Remarks
R668	ERDS2TJ154	1/4W 150K	R921	ERDS2EJ121	1/4W 120	R1055, 1056	ERDS2TJ473	1/4W 47K
R669	ERDS2TJ223	1/4W 22K	R922	ERDS2TJ472	1/4W 4.7K	R1061	ERDS2TJ222	1/4W 2.2K
R670	ERD25FJ470	1/4W 47 Δ	R923	ERDS2TJ102	1/4W 1K	R1071, 1072	ERDS2TJ222	1/4W 2.2K
R671	ERDS2TJ103	1/4W 10K	R926	ERDS2TJ122	1/4W 1.2K	R1073, 1074	ERDS2TJ332	1/4W 3.3K E, EB, EG
R673	ERDS2TJ684	1/4W 680K	R927	ERDS2TJ181T	1/4W 180	R1073, 1074	ERDS2TJ682T	1/4W 6.8K G, GN
R674	ERDS2TJ473	1/4W 47K	R928	ERDS2TJ222	1/4W 2.2K	R1075, 1076	ERDS2TJ473	1/4W 47K
R676	ERDS2TJ223	1/4W 22K	R929	ERDS2TJ562	1/4W 5.6K	R1201, 1202	ERDS2TJ102	1/4W 1K
R677	ERDS2TJ103	1/4W 10K	R930, 931	ERDS2TJ101	1/4W 100	R1204, 1205	ERDS2TJ102	1/4W 1K
R678	ERDS1FVJ561T	1/2W 560 Δ	R946-949	ERDS2TJ103	1/4W 10K	R1207-1216	ERDS2TJ102	1/4W 1K
R679	ERDS2TJ222	1/4W 2.2K	R950	ERDS2TJ102	1/4W 1K			CAPACITORS
R680	ERDS2TJ333	1/4W 33K	R951	ERDS2TJ122	1/4W 1.2K			
R681-694	ERDS2TJ270T	1/4W 27	R952	ERDS2TJ152	1/4W 1.5K	C101	ECBT1C103NS5	16V 0.01U
R695, 696	ERDS2TJ102	1/4W 1K	R953	ERDS2TJ182	1/4W 1.8K	C103	ECBT1C103NS5	16V 0.01U
R697, 698	ERDS2TJ221	1/4W 220	R954	ERDS2TJ222	1/4W 2.2K	C104	ECBT1H102KB5	50V 1000P
R699	ERDS2TJ332	1/4W 3.3K	R955	ERDS2TJ332	1/4W 3.3K	C105	ECBT1H470J5	50V 47P
R703, 704	ERDS1FVJ3R9T	1/2W 3.9 Δ	R956	ERDS2TJ472	1/4W 4.7K	C106	ECBT1C103NS5	16V 0.01U
R705	ERDS2TJ472	1/4W 4.7K	R957	ERDS2TJ682T	1/4W 6.8K	C107	ECBT1H473ZF5	50V 0.047U
R706	ERDS2TJ102	1/4W 1K	R960	ERDS2TJ102	1/4W 1K	C108	ECBT1H100JC5	50V 10P E, EB, G, GN
R709	ERD25FVJ221T	1/4W 220 Δ	R961	ERDS2TJ122	1/4W 1.2K	C108	ECBT1H82KC5	50V 8.2P EG
R712	ERDS2TJ472	1/4W 4.7K	R962	ERDS2TJ152	1/4W 1.5K	C109, 110	ECBT1C103NS5	16V 0.01U
R713, 714	ERDS2TJ185T	1/4W 1.5	R963	ERDS2TJ182	1/4W 1.8K	C111	ECEALEKA4R7B	25V 4.7U
R715	ERDS2TJ752T	1/4W 7.5K	R964	ERDS2TJ222	1/4W 2.2K	C112	ECBT1C103NS5	16V 0.01U
R716	ERDS2TJ682T	1/4W 6.8K	R965	ERDS2TJ332	1/4W 3.3K	C113	ECBT1H102KB5	50V 1000P
R717	ERDS1FVJ220T	1/2W 22 Δ	R966	ERDS2TJ472	1/4W 4.7K	C114	ECEALHKA3R3B	50V 3.3U
R718	ERDS2TJ182	1/4W 1.8K	R967	ERDS2TJ682T	1/4W 6.8K	C115	ECEALEKA4R7B	25V 4.7U
R721	ERDS1FVJ4R7T	1/2W 4.7 Δ	R970	ERDS2TJ102	1/4W 1K	C116	ECBT1C822MS5	16V 8200P
R722	ERD25FJ101	1/4W 100 Δ	R971	ERDS2TJ122	1/4W 1.2K	C117	ECQB1H471JF3	50V 470P
R723	ERDS2TJ472	1/4W 4.7K	R972	ERDS2TJ152	1/4W 1.5K	C118, 119	ECQB1H103JF3	50V 0.01U
R724	ERDS1FVJ6R8T	1/2W 6.8 Δ	R973	ERDS2TJ182	1/4W 1.8K	C120, 121	ECEALHKA010B	50V 1U
R725	ERDS2TJ152	1/4W 1.5K	R974	ERDS2TJ222	1/4W 2.2K	C122	ECEALHKA2R2B	50V 2.2U
R727	ERDS1FVJ4R7T	1/2W 4.7 E, EB, EG	R975	ERDS2TJ332	1/4W 3.3K	C123	ECEALHKA010B	50V 1U
R727	ERDS1FVJ2R2T	1/2W 2.2 G, GN	R976	ERDS2TJ472	1/4W 4.7K	C124	ECBT1H102KB5	50V 1000P
R754	ERDS2TJ102	1/4W 1K	R977	ERDS2TJ682T	1/4W 6.8K	C125	ECBT1H150JC5	50V 15P
R772	ERDS2TJ104	1/4W 100K	R978	ERDS2TJ123	1/4W 12K	C126	ECBT1H104ZF5	50V 0.1U
R773	ERDS2TJ103	1/4W 10K	R980	ERDS2TJ102	1/4W 1K	C127	ECEALCKA220B	16V 22U
R774	ERDS2TJ223	1/4W 22K	R981	ERDS2TJ122	1/4W 1.2K	C128	ECBT1C103NS5	16V 0.01U
R775	ERDS2TJ332	1/4W 3.3K	R982	ERDS2TJ152	1/4W 1.5K	C129, 130	ECEALHKA101B	6.3V 100U
R776	ERDS1FVJ220T	1/2W 22 Δ	R983	ERDS2TJ182	1/4W 1.8K	C131	ECBT1C103NS5	16V 0.01U
R777	ERDS2TJ220T	1/4W 22	R984	ERDS2TJ222	1/4W 2.2K	C132	ECBT1H102KB5	50V 1000P
R778	ERDS2TJ222	1/4W 2.2K	R985	ERDS2TJ332	1/4W 3.3K	C133	ECBT1H150JC5	50V 15P
R779	ERDS2TJ103	1/4W 10K	R986	ERDS2TJ472	1/4W 4.7K	C134	ECBT1H180JC5	50V 18P
R780, 781	ERDS2TJ333	1/4W 33K	R987	ERDS2TJ682T	1/4W 6.8K	C135, 136	ECBT1C103KS5	16V 0.01U
R782	ERDS2TJ153	1/4W 15K	R991	ERDS2TJ103	1/4W 10K	C137, 138	ECBT1H561KB5	50V 560P
R783	ERDS2TJ103	1/4W 10K	R1001, 1002	ERDS2TJ223	1/4W 22K	C139, 140	ECQB1H682JF3	50V 6800P
R784	ERDS2TJ335T	1/4W 3.3M	R1003, 1004	ERDS2TJ102	1/4W 1K	C141-144	ECEALHKA010B	50V 1U
R791-796	ERDS2TJ223	1/4W 22K	R10					

Ref. No.	Part No.	Values & Remarks	Ref. No.	Part No.	Values & Remarks	Ref. No.	Part No.	Values & Remarks
C173	ECEA1CKA220B	16V 22U	C561, 562	ECEA1HKA3R3B	50V 3. 3U	C771	ECEA1HKA2R2B	50V 2. 2U
C174	ECEA1CKA101B	16V 100U	C563	ECEA1HKN010B	50V 1U	C772	ECEA1CKA100B	16V 10U
C175, 176	ECBT1C103NS5	16V 0. 01U	C601, 602	ECEA1HKN3R3B	50V 3. 3U	C773	ECBT1E223ZF	25V 0. 022U
C181	ECBT1H471KB5	50V 470P	C603, 604	ECBT1H181KB5	50V 180P	C774	RCE0JKA221BV	6. 3V 220U
C196	ECBT1H102KB5	50V 1000P	C605, 606	RCE1JU220BV	63V 22U	C891	ECFR1E392KR	25V 3900P
C351, 352	ECEAOJKA101B	6. 3V 100U	C607, 608	ECCR1H100K5	50V 10P	C901	ECAOJM102B	6. 3V 1000U
C353	ECEA1CKA100B	16V 10U	C609, 610	ECBT1H221KB5	50V 220P	C902, 903	ECBT1E103ZF	25V 0. 01U
C401, 402	ECEA1VKA4R7B	35V 4. 7U	C611, 612	ECQV1H473JM3	50V 0. 047U	C904	ECAOJM471B	6. 3V 470U
C403, 404	ECBT1E103ZF	25V 0. 01U	C613, 614	ECBA1H681KB5	50V 680P	C906	ECEAOJKA101B	6. 3V 100U
C405, 406	ECBT1H101KB5	50V 100P	C615	ECA1HM470B	50V 47U	C908	ECBT1E103ZF	25V 0. 01U
C409, 410	ECEA1CKA220B	16V 22U	C616	ECEA2AU100	100V 10U	C909-912	RCE1JU220BV	63V 22U
C411, 412	ECBT1H101KB5	50V 100P	C617	RCE1JU220BV	63V 22U	C913, 914	ECEA1VKA100B	35V 10U
C413, 414	ECEA1CKA100B	16V 10U	C618	ECEA2AN2R2SB	100V 2. 2U	C916	ECEA1HKA010B	50V 1U
C415, 416	ECBT1E103ZF	25V 0. 01U	C621, 622	ECEA2AU100	100V 10U	C919	ECBT1E103ZF	25V 0. 01U
C417, 418	ECBT1H101KB5	50V 100P	C631-634	ECKT1H223ZF	50V 0. 022U	C920	ECEA1HKA010B	50V 1U
C419-422	ECBT1H331KB5	50V 330P	C635, 636	ECKR1H03ZF5	50V 0. 01U	C921-928	ECBT1H331KB5	50V 330P
C423-426	ECBT1H101KB5	50V 100P	C637	ECKT1H223ZF	50V 0. 022U	C929, 930	ECBT1H101KB5	50V 100P
C427, 428	ECBT1H221KB5	50V 220P	C651, 652	ECEA1HKN3R3B	50V 3. 3U	C935	ECEAOJKA101B	6. 3V 100U
C431, 432	ECEA1CKA100B	16V 10U	C653, 654	ECBA1H681KB5	50V 680P	C936	ECBT1E103ZF	25V 0. 01U
C440	ECBT1E103ZF	25V 0. 01U	C655, 656	ECEA1CKA220B	16V 22U	C937-939	ECBT1H101KB5	50V 100P
C451, 452	ECEA1VKA4R7B	35V 4. 7U	C657, 658	ECCR1H100K5	50V 10P	C944	ECBT1H101KB5	50V 100P
C453, 454	ECBT1H100JC5	50V 10P	C659, 660	ECBT1H151KB5	50V 150P	C945	ECBT0J223MS5	6. 3V 0. 022U
C455, 456	ECBT1H102KB5	50V 1000P	C661, 662	ECQV1H473JM3	50V 0. 047U	C1001, 1002	ECEA1HKA010B	50V 1U
C457, 458	ECEA1AKA330B	10V 33U	C665	ECA1HM470B	50V 47U	C1003, 1004	ECEA1HKA3R3B	50V 3. 3U
C459, 460	ECFR1E223KR	25V 0. 022U	C667	RCE1JU220BV	63V 22U	C1005	ECEA1HKA010B	50V 1U
C461, 462	ECFR1E682KR	25V 6800P	C668	ECEA2AU100	100V 10U	C1007	ECFR1E223KR	25V 0. 022U
C463, 464	ECEA1VKA4R7B	35V 4. 7U	C669	ECEA2AN2R2SB	100V 2. 2U	C1008	ECFR1E473KR	25V 0. 047U
C465, 466	ECBT1E103ZF	25V 0. 01U	C681, 682	ECEA1HN100SB	50V 10U	C1009	RCE0JKA221BV	6. 3V 220U
C469, 470	ECBT1H181KB5	50V 180P	C683, 684	ECBT1C332KR5	16V 3300P	C1010-1013	ECEA1CKA100B	16V 10U
C503, 504	ECEAOJKA101B	6. 3V 100U	C685	ECBT1E103ZF	25V 0. 01U	C1014	RCE0JKA221BV	6. 3V 220U
C505, 506	ECFR1E104KR	25V 0. 1U	C691	ECKT1H101KB	50V 100P	C1015, 1016	ECQV1H104JM3	50V 0. 1U
C511, 512	ECEA1HKA3R3B	50V 3. 3U	C701	ECBT1E103ZF	25V 0. 01U	C1017	ECEA1HKA47B	50V 0. 47U
C513, 514	ECBT1H150J5	50V 15P	C702	ECQE2104KF3	250V 0. 1U	C1018	ECEA1VKA4R7B	35V 4. 7U
C515, 516	ECBT1H221KB5	50V 220P	C703, 704	ECOS1JP682CZ	63V 6800U E, EB, EG Δ	C1019	ECEA1HKA47B	50V 0. 47U
C517, 518	ECBT1H330J5	50V 33P	C703, 704	ECE575V752UX	75V 7500U G, GN Δ	C1020	ECEA1VKA4R7B	35V 4. 7U
C519, 520	ECEA1VKA4R7B	35V 4. 7U	C705, 706	ECA1HM332B	50V 3300U Δ	C1021	ECEA1HKAR15B	50V 0. 15U
C521	ECEA1CKA220B	16V 22U	C707	RCE1VM101BV	35V 100U	C1022	ECEA1HKA3R3B	50V 3. 3U
C522	ECEA1CKA100B	16V 10U	C708	ECKR1H103ZF5	50V 0. 01U	C1023, 1024	ECQV1H154JM3	50V 0. 15U
C523, 524	ECFR1E123KR	25V 0. 012U	C709	ECEA1CKA330B	16V 33U	C1025	ECEA1HKA3R3B	50V 3. 3U
C525, 526	ECQV1H683JM3	50V 0. 068U	C710	ECBT1E103ZF	25V 0. 01U	C1026	ECEA1HKAR15B	50V 0. 15U
C527, 528	ECBT1C562KR5	16V 5600P	C711	ECKR1H103ZF5	50V 0. 01U	C1027	ECEA1VKA4R7B	35V 4. 7U
C529, 530	ECQB1H273JF3	50V 0. 027U	C712	ECEA1HKA100B	50V 10U	C1028	ECEA1HKAR47B	50V 0. 47U
C531, 532	ECBT1E103ZF	25V 0. 01U	C713	ECKR1H103ZF5	50V 0. 01U	C1029	ECEA1VKA4R7B	35V 4. 7U
C533	ECEA1CKA100B	16V 10U	C714	ECEA1CKA470B	16V 47U	C1030	ECEA1HKAR47B	50V 0. 47U
C534	ECEA1VKA4R7B	35V 4. 7U	C721	ECQE2104KF3	250V 0. 1U	C1031, 1032	ECQV1H104JM3	50V 0. 1U
C536	ECEA1HKN010B	50V 1U	C751	ECKWNS102MBM	400V 1000P Δ	C1033	ECEA1CKA470B	16V 47U
C537, 538	ECEA1CKA100B	16V 10U	C752	ECKR1H103ZF5	50V 0. 01U	C1034	ECQV1H474JM3	50V 0. 47U
C551, 552	ECEA1HKA3R3B	50V 3. 3U	C753	ECA1EM102B	25V 1000U Δ	C1035	ECBA1H681KB5	50V 680P
C553, 554	ECBT1H101KB5	50V 100P	C754	ECBT1E103ZF	25V 0. 01U	C1036-1038	ECBT1H101KB5	50V 100P
C555, 556	ECBT1H221KB5	50V 220P	C755	ECEA1CKA470B	16V 47U	C1039	ECEA1CKA101B	16V 100U
C557, 558	ECBT1E103ZF	25V 0. 01U	C756	ECBT1H101KB5	50V 100P	C1040	ECEA1CKA100B	16V 10U
C559, 560	ECEA1CKA100B	16V 10U	C758	ECEA1AKA101B	10V 100U	C1041	ECBT1E103ZF	25V 0. 01U



Ref. No.	Part No.	Values & Remarks	Ref. No.	Part No.	Values & Remarks	Ref. No.	Part No.	Values & Remarks
C1051	ECEA1HKA2R2B	50V 2.2U	C1057	ECFR1E152KR	25V 1500P	C1065	ECBA1H681KB5	50V 680P
C1052	ECEA1HKA010B	50V 1U	C1058	ECFR1E333KR	25V 0.033U	C1067, 1068	ECBT1C152KR5	16V 1500P
C1053	ECEA1HKA3R3B	50V 3.3U	C1059	ECEA1CKA101B	16V 100U	C1071, 1072	ECEA1HKA3R3B	50V 3.3U
C1054	RCE0JKA221BV	6.3V 220U	C1060	ECBT1E223ZF	25V 0.022U	C1073, 1074	ECEA1CKA100B	16V 10U
C1055	ECEA1HKA010B	50V 1U	C1062	ECBT1E223ZF	25V 0.022U			
C1056	ECFR1E333KR	25V 0.033U	C1063	ECEA1CKA101B	16V 100U			

## REPLACEMENT PARTS LIST

### Notes: \*Important safety notice:

Components identified by  $\Delta$  mark have special characteristics important for safety.

Furthermore, special parts which have purposes of fire-retardant (resistors), high-quality sound (capacitors), low-noise (resistors), etc. are used.

When replacing any of components, be sure to use only manufacturer's specified parts shown in the parts list.

\*The parenthesized indications in the Remarks columns specify the areas. (Refer to the cover page for area.)

Parts without these indications can be used for all areas.

\*Remote Control Ass'y: Supply period for three years from termination of production.

\*The "(SF)" mark denotes the standard part.

Ref. No.	Part No.	Part Name & Description	Remarks	Ref. No.	Part No.	Part Name & Description	Remarks
		PACKING MATERIAL		A2	RJA0019-2K	AC POWER SUPPLY CORD	(E, EG, G) $\Delta$ (SF)
				A2	VJA0733	AC POWER SUPPLY CORD	(EB) $\Delta$ (SF)
				A2	RJA0036-K	AC POWER SUPPLY CORD	(GN) $\Delta$ (SF)
P1	RPG2081	PACKING CASE	(E, EG, G, GN)	A3	RSA0007	FM INDOOR ANTENNA	
P1	RPG2082	PACKING CASE	(EB)	A4	RSA0010	AM LOOP ANTENNA SET	
P2	RPND752	CUSHION		A4-1	RMND244	AM ANTENNA HOLDER	
P3	RPQ0164	PAD		A4-2	XTN3+10AFZ	SCREW	
P4	RPH0032	MIRROR SHEET	(EB, GN)	A5	RQCB0169	SERVICENTER LIST	
P5	XZB60X65A01Z	PROTECTION BAG (UNIT)		A6	RQA0013	WARRANTY CARD	(E, EB, EG)
P6	RPF0134	PROTECTION BAG (F. B.)		A6	RQX7433ZA	WARRANTY CARD	(GN)
		ACCESSORIES		A7	RAK-SA114XH	REMOTE CONTROL TRANSMITTER	
				A7-1	RKN0057-K	BATTERY COVER	FOR R/C TRANSMITTER
A1	RFKSAGX470E	INSTRUCTION MANUAL ASS'Y	(E)	A8	SJP9009	ATTACHMENT PLUG	(EB) $\Delta$
A1	RFKSAGX470EB	INSTRUCTION MANUAL ASS'Y	(EB, GN)	A9	RFE0014	ANTENNA PLUG	(G, GN)
A1	RFKSAGX470EG	INSTRUCTION MANUAL ASS'Y	(EG)	A10	RQLA0134	VOLTAGE CAUTION LABEL	(G)
A1	RFKSAGX470G	INSTRUCTION MANUAL ASS'Y	(G)	A11	SJP5213-1	POWER PLUG ADAPTOR	(G) $\Delta$

## PACKAGING

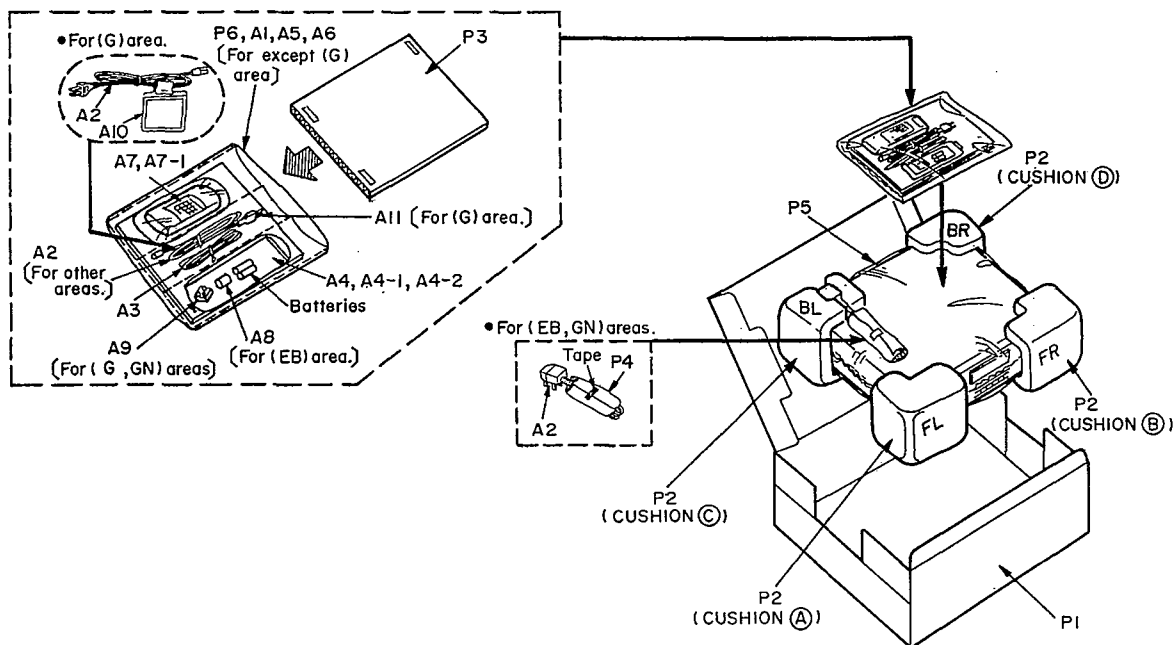

(CUSHION (A), (B), (C), (D) : RPND752)

Printed in Japan  
H940611000 NH/YU/TM