

Service Manual

AV Control Stereo Receiver



Receiver

SA-GX530

Colour

(K) ... Black Type

Area

Suffix for Model No.	Area	Colour
(E)	Europe.	(K)
(EB)	Great Britain.	
(EG)	Germany and Italy.	
(G)	Asia, Latin America, Middle Near East and Africa.	
(GN)	Oceania.	

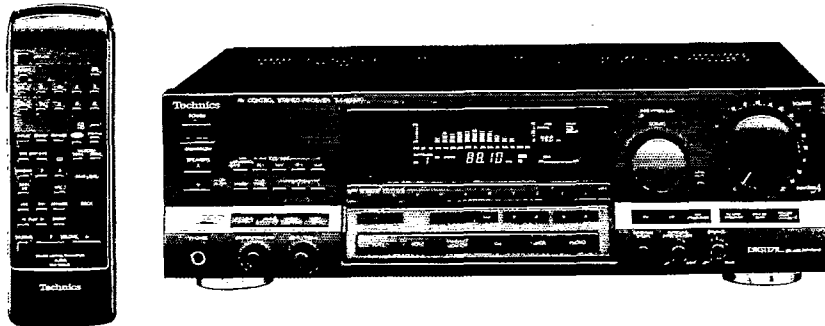

SPECIFICATIONS (DIN 45 500)

■ AMPLIFIER SECTION

Power output	
DIN 1 kHz (T.H.D. 1%)	2 × 100 W (4 Ω)
20 Hz~20 kHz continuous power output both channels driven	2 × 65 W (8 Ω)
Total harmonic distortion	
rated power at 20 Hz~20 kHz	0.05% (8 Ω)
half power at 1 kHz	0.03% (8 Ω)
Intermodulation distortion	
rated power at 60 Hz: 7 kHz = 4:1, SMPTE	0.5% (8 Ω)
Power bandwidth	
both channels driven, -3 dB	10 Hz~40 kHz (8 Ω)
Damping factor	40 (8 Ω)
Input sensitivity and impedance	
PHONO	3 mV/47 kΩ
CD, VCR 1, VCR 2, TAPE/DAT	200 mV/22 kΩ
PHONO maximum input voltage (1 kHz, RMS)	150 mV
S/N at rated power (8 Ω)	
PHONO	70 dB (IHF, A: 80 dB)
CD, VCR 1, VCR 2, TAPE/DAT	80 dB (IHF, A: 90 dB)
Frequency response	
PHONO	RIAA standard curve (30 Hz~15 kHz) ±0.8 dB
CD, VCR 1, VCR 2, TAPE/DAT	10 Hz~40 kHz, ±3 dB
Tone controls	
BASS	50 Hz, +10~-10 dB
TREBLE	20 kHz, +10~-10 dB
4 band parametric equalizer	+10~-10 dB
Loudness control (volume at -30 dB)	50 Hz, +9 dB
Output voltage	
VCR 1 OUT, TAPE/DAT REC (OUT)	200 mV
Channel balance (250 Hz~6.3 kHz)	±1 dB
Channel separation	55 dB
Headphones output level and impedance	430 mV/330 Ω

* Manufactured under license from Dolby Laboratories Licensing Corporation. Additionally licensed under one or more of the following patents: U.S. numbers 3,632,886, 3,746,792 and 3,959,590; Canadian numbers 1,004,603 and 1,037,877.

"Dolby" and the double-D symbol are trademarks of Dolby Laboratories Licensing Corporation.

Load Impedance

A or B	4~16 Ω
A and B	8~16 Ω

■ SURROUND AMPLIFIER SECTION

Power output (REAR)	1 kHz, 10 W (8 Ω) (T.H.D. 0.8%)
Power output (CENTER)	1 kHz, 15 W (8 Ω) (T.H.D. 0.8%)

■ FM TUNER SECTION

Frequency range	87.50~108.00 MHz
Sensitivity	
S/N 30 dB	1.5 μV/75 Ω
S/N 26 dB	1.3 μV/75 Ω
S/N 20 dB	1.2 μV/75 Ω
IHF usable sensitivity	(IHF '58) 1.5 μV/75 Ω
IHF 46 dB stereo quieting sensitivity	22 μV/75 Ω
Total harmonic distortion	
MONO	0.2%
STEREO	0.3%
S/N	
MONO	60 dB (75 dB, IHF)
STEREO	58 dB (71 dB, IHF)
Frequency response	20 Hz~15 kHz, +1 dB, -2 dB
Alternate channel selectivity	
±400 kHz	65 dB
Capture ratio	1.0 dB
Image rejection at 98 MHz	40 dB
IF rejection at 98 MHz	70 dB
Spurious response rejection at 98 MHz	70 dB
AM suppression	50 dB
Stereo separation	
1 kHz	40 dB

Technics

Carrier leak	
19 kHz	-55 dB (-60 dB, IHF)
38 kHz	-50 dB (-55 dB, IHF)
Channel balance (250 Hz~6.3 kHz)	±1.5 dB
Limiting point	1.2 μV
Bandwidth	
IF amplifier	180 kHz
FM demodulator	1000 kHz
Antenna terminals	75 Ω (unbalanced)

■ AM TUNER SECTION

• For (E, EB, G, GN) areas.

Frequency range	
MW	522~1611 kHz (9-kHz steps) 530~1620 kHz (10-kHz steps)
LW	144~288 kHz

Sensitivity (S/N 20 dB)	
MW	20 μV, 330 μV/m
LW	45 μV

Selectivity	
MW (at 999 kHz)	55 dB
LW (at 252 kHz)	55 dB

Image rejection	
MW (at 999 kHz)	40 dB
LW (at 252 kHz)	40 dB

IF rejection	
MW (at 999 kHz)	55 dB
LW (at 252 kHz)	55 dB

• For (EG) area.

Frequency range	522 kHz~1611 kHz (9-kHz-Schritte) 530 kHz~1620 kHz (10-kHz-Schritte)
Selectivity (S/N 20 dB)	20 μV, 330 μV/m

■ CONTENTS

	Page
ACCESSORIES.....	2
CONNECTIONS	3, 4
SPEAKER CONNECTIONS.....	5, 6
FRONT PANEL CONTROLS AND FUNCTIONS	7~11
REMOTE CONTROL OPERATION.....	12, 13
MUTUAL OPERATIONS	14, 15
DISASSEMBLY INSTRUCTIONS	16~21
PROTECTION CIRCUITRY.....	21
BEFORE REPAIR AND ADJUSTMENT.....	21
MEASUREMENTS AND ADJUSTMENTS.....	22
INTERNAL CONNECTION OF FL.....	23, 24

Selectivity at 999 kHz	55 dB
Image rejection at 999 kHz	40 dB
IF rejection at 999 kHz	55 dB

■ VIDEO SECTION

Output voltage at 1 V input (unbalanced)	1 ±0.1 Vp-p
Maximum input voltage	1.5 Vp-p
Input/output impedance	75 Ω (unbalanced)

■ GENERAL

Power consumption	260 W
Power supply	
For (E, EB, GN) areas.	AC 50 Hz/60 Hz, 230 V/240 V
For (EG) area.	AC 50 Hz/60 Hz, 230 V
For (G) area.	AC 50 Hz/60 Hz, 110 V/127 V/230 V/240 V
Dimensions (W×H×D)	430×134×305 mm
Weight	10 kg

■ REMOTE CONTROL TRANSMITTER





Control keys	37 keys
Dimensions (W×H×D)	70×28×215 mm
Weight (including batteries)	160 g
Power source	Two UM-4 (Panasonic R03/LR03 or equivalent)

Notes:

- Specifications are subject to change without notice. Weight and dimensions are approximate.
- Total harmonic distortions is measured by the digital spectrum analyzer.

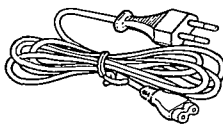
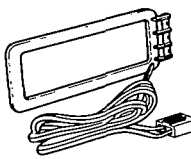
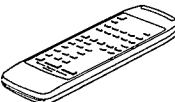
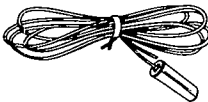
	Page
BLOCK DIAGRAM.....	25~28
TERMINAL GUIDE OF IC'S, TRANSISTORS AND DIODES.....	28
SCHEMATIC DIAGRAM.....	29~51
PRINTED CIRCUIT BOARDS	52~62
WIRING CONNECTION DIAGRAM.....	63
TERMINAL FUNCTION OF IC'S	64, 65
REPLACEMENT PARTS LIST	66~70
PACKAGING.....	70
CABINET PARTS LOCATION.....	71, 72
RESISTORS AND CAPACITORS	73~76

■ ACCESSORIES

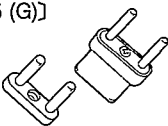
<ul style="list-style-type: none"> • AC power supply cord 1 pc. [RJA0019-1K (E, EG), SJA193 (EB)] [RJA0004 (G), SJA173 (GN)] 	<ul style="list-style-type: none"> • AM loop antenna 1 pc. [SPB1163T] 	<ul style="list-style-type: none"> • Remote control transmitter (RAK-SA503E)..... 1 pc. 
<ul style="list-style-type: none"> • FM indoor antenna 1 pc. [RSA0007 (E, EB, EG)] [RSA0006 (G, GN)] 	<ul style="list-style-type: none"> • AM antenna holder 1 pc. [SMA233-1M] 	<ul style="list-style-type: none"> • Batteries 2 pcs. for remote control transmitter (UM-4/R03) 
	<ul style="list-style-type: none"> • Screws..... 2 pcs. [XTN3+10AFZ] 	<ul style="list-style-type: none"> • Attachment plug 1 pc. [SJP9009 (EB)] 
		<ul style="list-style-type: none"> • AC plug adaptor 1 pc. [SJP9215 (G)] 

CONNECTIONS

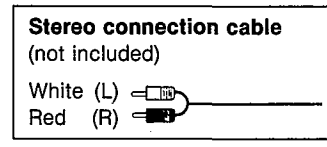
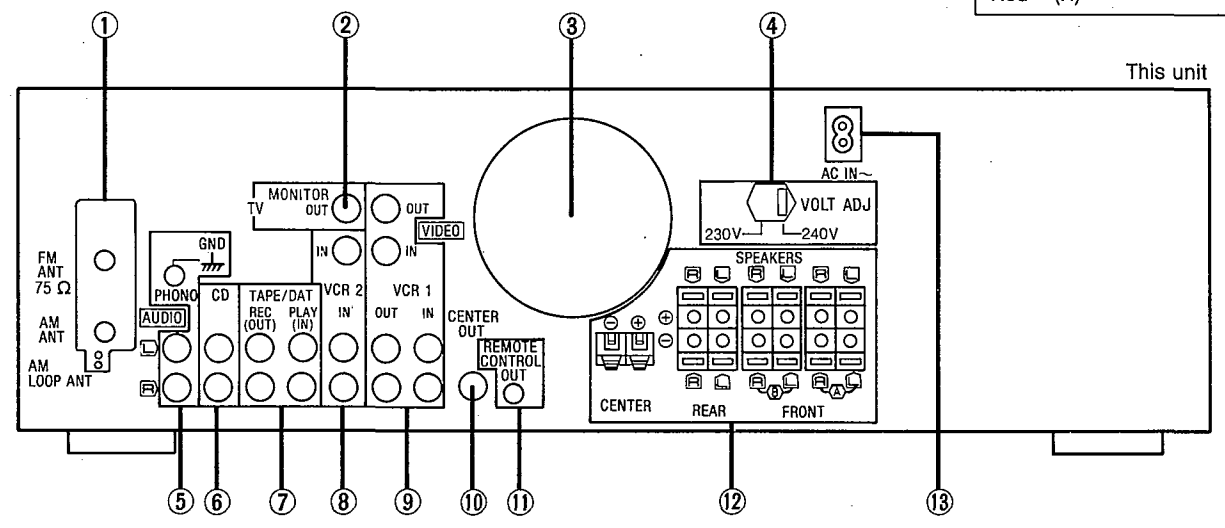

① **Antenna connection terminals**

② **"TV MONITOR OUT" terminal**
Connect a video connection cable (not included) to the video input terminal of TV or projection TV.

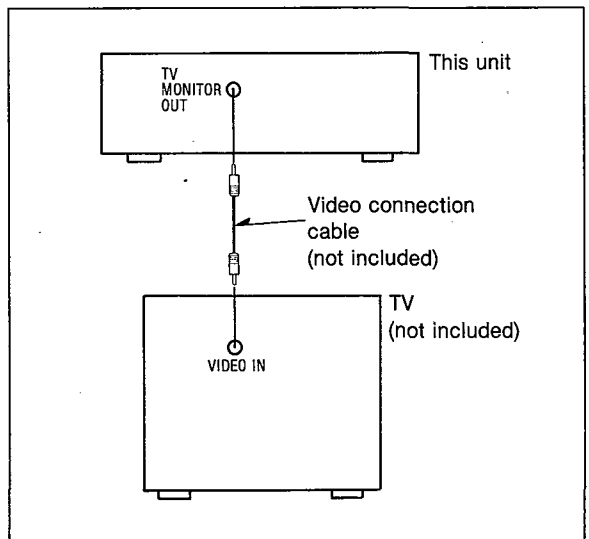

③ **Cooling fan**
The cooling fan operates at high output power levels only.

④ **Voltage selector (VOLT ADJ)**
See page 6 for detailed information.

⑤ **"PHONO" terminals**
Connect a turntable only. Do not connect any other sound source to these terminals.

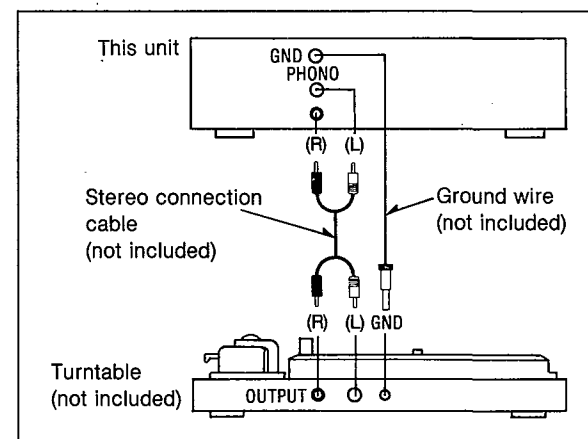

⑥ **"CD" terminals**
Connect a compact disc player.

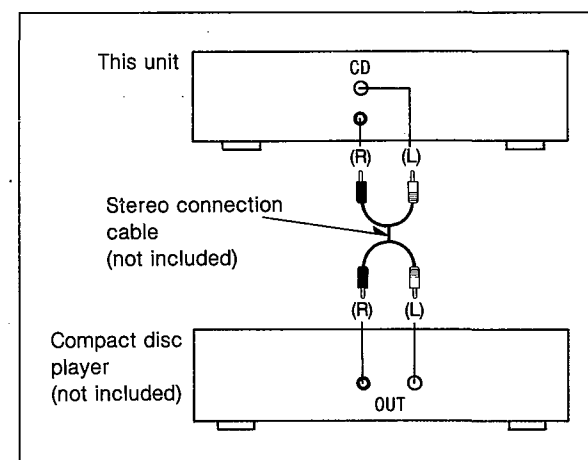

⑦ **"TAPE/DAT" terminals**
Connect a tape deck or a digital audio tape deck (DAT).

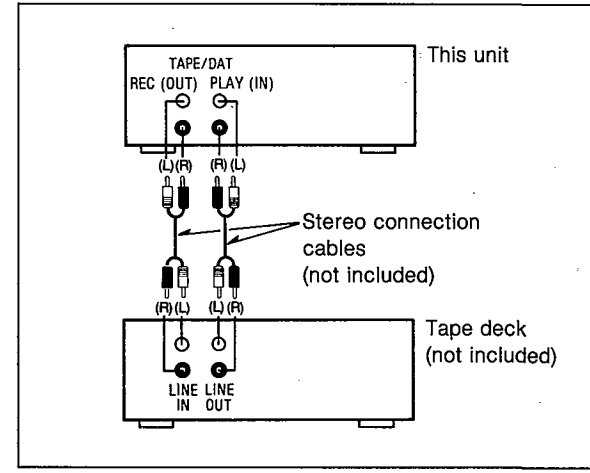

⑧ **"VCR 2" terminals**
Connect a second VCR or a laser disc player.

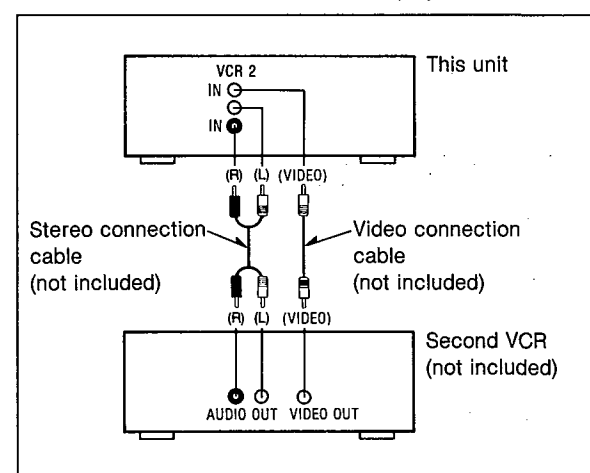

⑨ **"VCR 1" terminals**
Connect a VCR.

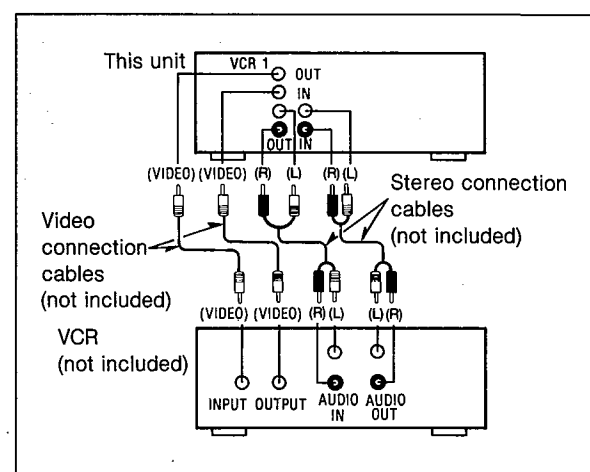

⑩ **"CENTER OUT" terminal**
See page 6 for detailed information.

⑪ **Remote control OUT terminal (REMOTE CONTROL OUT)**
This terminal can be used only with Technics components which have the appropriate remote control terminal. (Consult your dealer for details.) Proper connection with remote control connection cables SJP2257T will allow control of some functions from this unit's remote control transmitter. (See pages 12-13 for details.)

Connect to a tape deck and/or compact disc player as shown below.

If a tape deck is not being used, the compact disc player can be connected directly (dotted line).

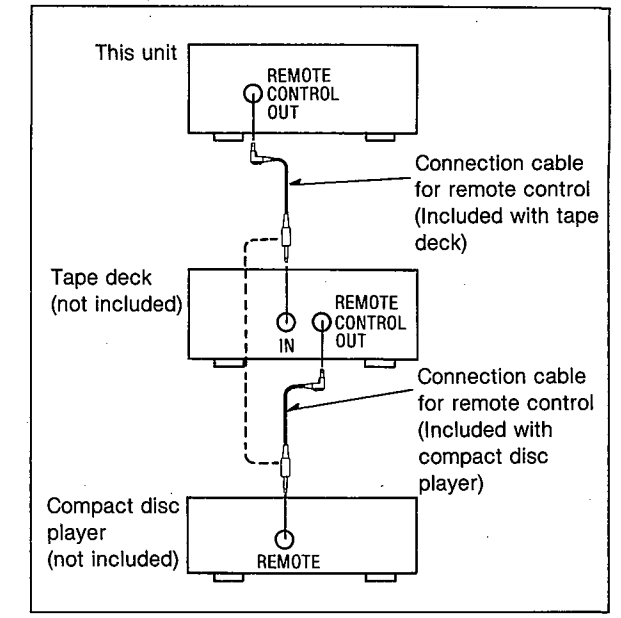

Note:
For a compact disc player with a remote control sensor the above connection is not necessary.

⑫ **Speaker connection terminals**
See pages 5-6 for detailed information.

⑬ **AC IN socket (AC IN)**
See page 6 for detailed information.

SPEAKER CONNECTIONS

To connect speakers

Placement of speakers

The illustration below is an example when enjoying Dolby Pro-Logic Surround.

Apart from this, the "PHANTOM mode" of the Dolby Pro-Logic Surround can be enjoyed even on systems which do not have center speakers connected, and "Dolby 3 stereo" can be enjoyed on systems which do not have rear speakers connected.

The listening position at which the effect is the greatest is a position slightly to the rear of a center position of five-speaker systems.

However the position should be adjusted to your personal preference, because the effect varies to some degree depending upon the type of music and the music source.

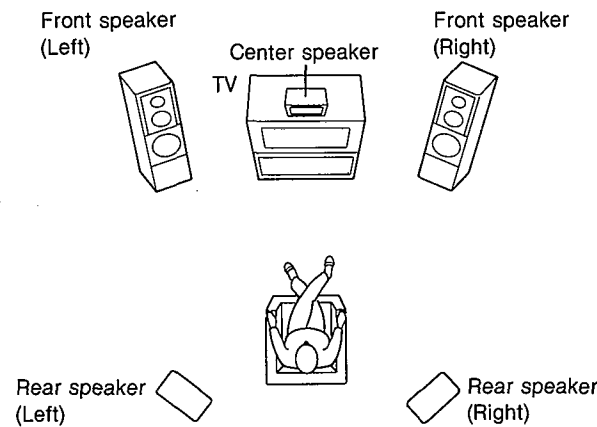

Connection of front speakers

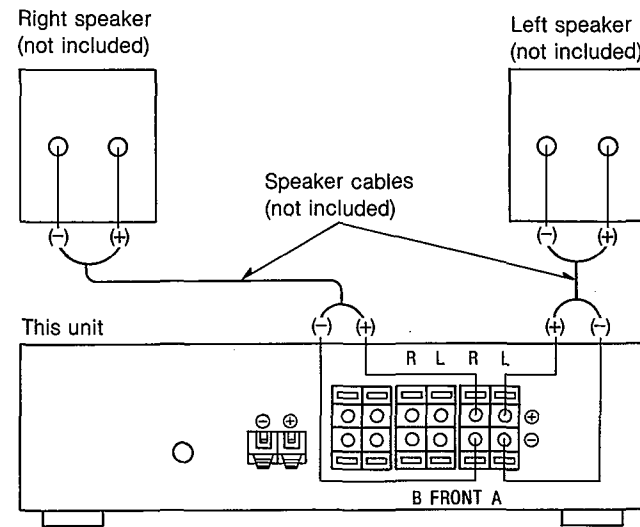

"B" terminals

For connection to a second pair of speakers.

Speaker impedance

- When only the "A" or only the "B" speakers are connected: 4-16 ohms.
- When both the "A" and the "B" speakers are connected simultaneously: 8-16 ohms.

Connection of rear speakers

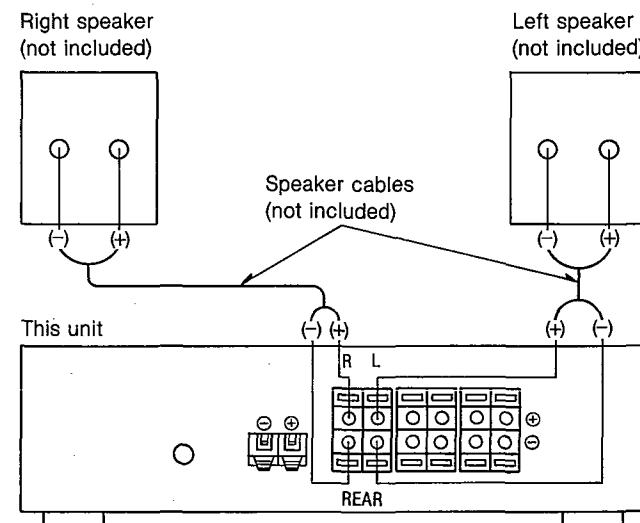

Speaker impedance

The impedance of any speaker used with this unit must be 8-16 Ω.

Connection of center speaker

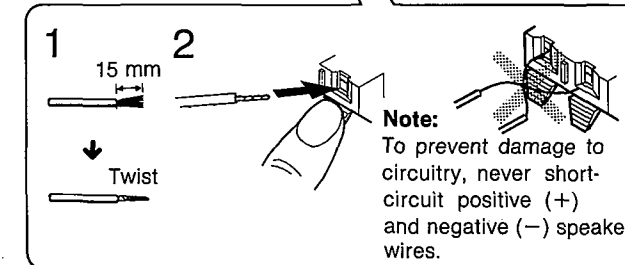
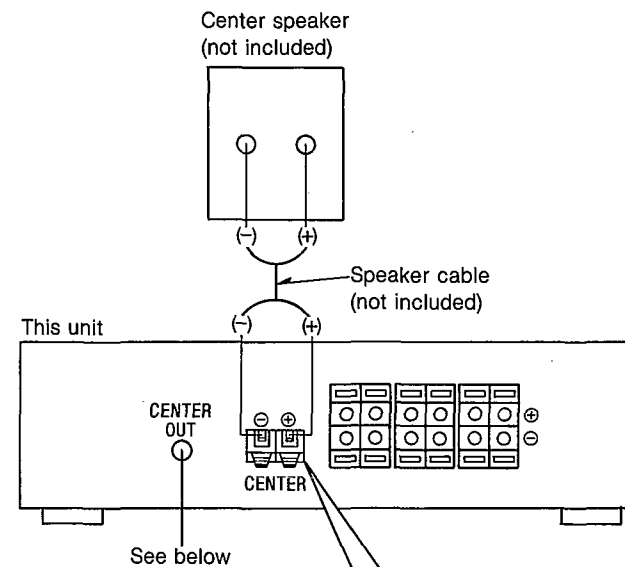

Speaker impedance

The impedance of any speaker used with this unit must be 8-16 Ω.

Using the TV speakers as the center speakers

You can use the TV speaker as the center speaker by connecting it as shown below.

When using the speakers, after setting the volume level of TV to MAX, adjust the center level on this unit.

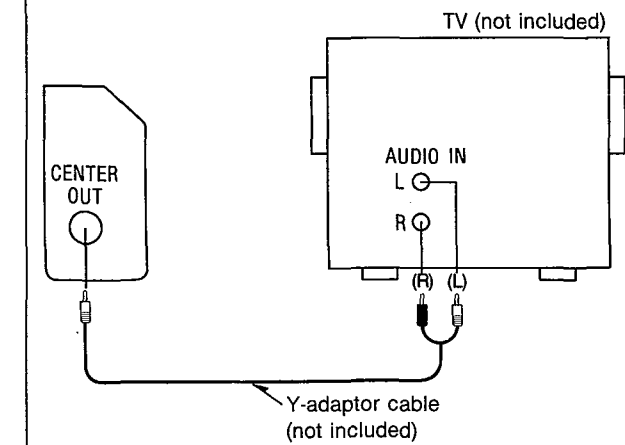

To set the power voltage

Set the voltage selector to the voltage setting for the area in which the unit will be used.

[Use a minus (-) screwdriver]

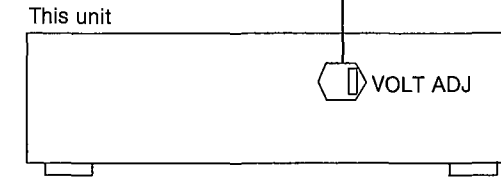

Note:

Note that this unit will be seriously damaged if this setting is not made correctly.

To connect the AC power supply cord (included)

Connect the AC power supply cord (included) after all other cables are connected.

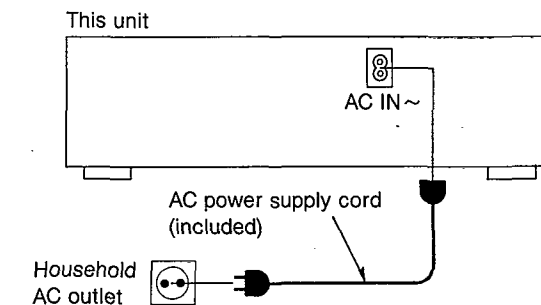

To connect speaker connection cables to terminals (FRONT, REAR)

Be sure to only connect positive (+) wires to positive (+) terminals, and negative (-) wires to negative (-) terminals.

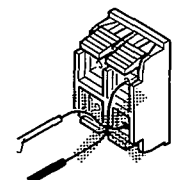
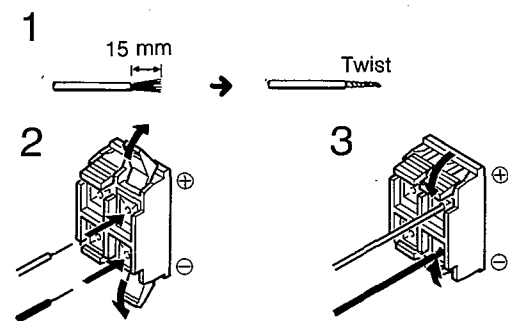

Note:

To prevent damage to circuitry, never short-circuit positive (+) and negative (-) speaker wires.

FRONT PANEL CONTROLS AND FUNCTIONS

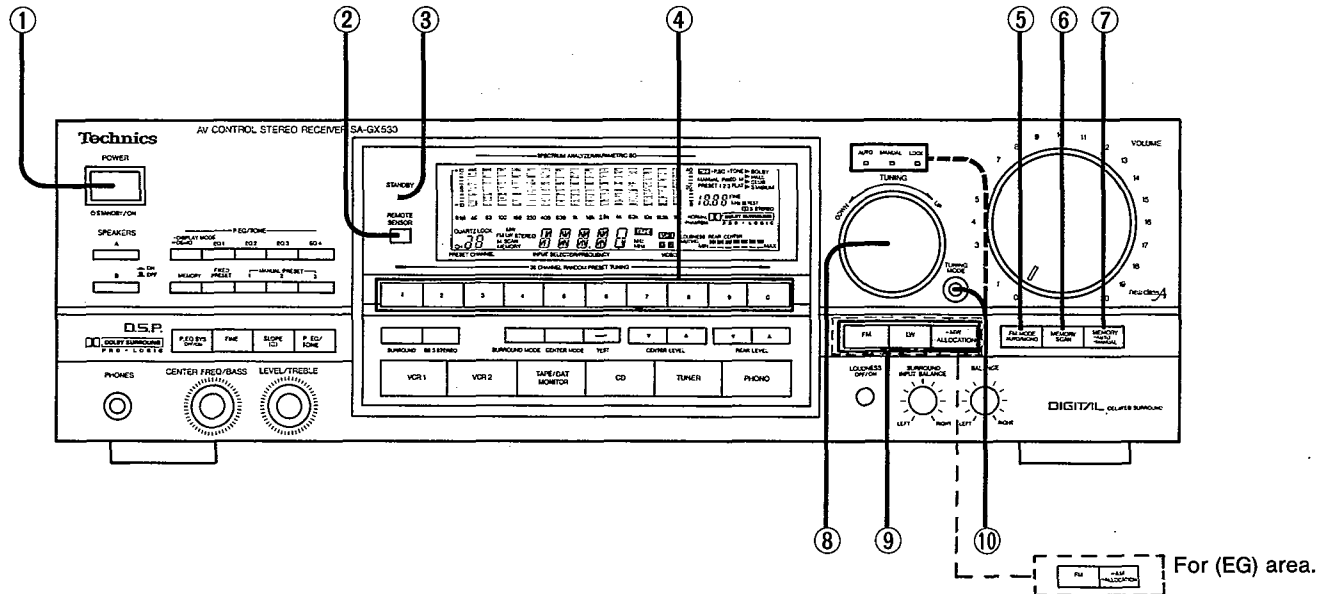

Tuner section

- ① **Power “ ϕ STANDBY/ON” switch (POWER, ϕ STANDBY/ON)**
This switch switches ON and OFF the secondary circuit power only. The unit is in the “standby” condition when this switch is set to the ϕ STANDBY position. Regardless of the switch setting, the primary circuit is always “live” as long as the power cord is connected to an electrical outlet.
- ② **Remote control signal receptor (REMOTE SENSOR)**
Receives the signals from the remote control transmitter.
- ③ **“STANDBY” indicator (STANDBY)**
This indicator illuminates when the “STANDBY” mode is set by the main unit or the remote control transmitter.
- ④ **Preset-tuning buttons (1–0) (30 CHANNEL RANDOM PRESET TUNING)**
These buttons are used to preset broadcast frequencies into the memory of this unit and to recall the desired preset stations.
- ⑤ **FM mode selector (FM MODE)**
This unit automatically switches to the stereo mode when an FM stereo broadcast is received. This selector is used to select the mode (stereo or monaural) of FM broadcast signals.
- ⑥ **Memory scan button (MEMORY SCAN)**
This button is used to locate a desired broadcast station; each broadcast station is selected for about 3 seconds.
- ⑦ **Memory button (MEMORY)**
This button is used when presetting broadcast station frequencies into memory.
- ⑧ **Tuning control (TUNING)**
This control is used to select an FM, MW or LW broadcast. When turning the control to the left, the frequency changes downward. When turning the control to the right, the frequency changes upward.
- ⑨ **Band selectors (FM, LW, MW)**
FM: Press this button to listen to an FM broadcast.
LW: Press this button to listen to an LW broadcast.
MW (E, EB)/AM (EG): Press this button to listen to an MW/AM broadcast.
ALLOCATION: When the MW button is pressed for about 4 seconds, the MW frequency step will change to 10 kHz per step. (This step is set to 9 kHz before shipment.) In order to return to the original frequency indication, press this button for about 4 seconds again.
- ⑩ **Tuning-mode selector/indicator (TUNING MODE)**
Each time this selector is pressed, the selection changes, in sequence, to “AUTO”, “MANUAL” and “LOCK”.
AUTO:
In this position, broadcast channels are automatically selected when the tuning control is momentarily turned to the left or right to start the frequency changing.
MANUAL:
In this position, the tuning control can be used to locate the desired channel manually.
The frequency changes only as the tuning control is turned to the right to left.
LOCK:
In this position, the broadcast channel presently being heard is locked in, and other broadcast stations cannot be tuned to, even if the tuning control is turned.

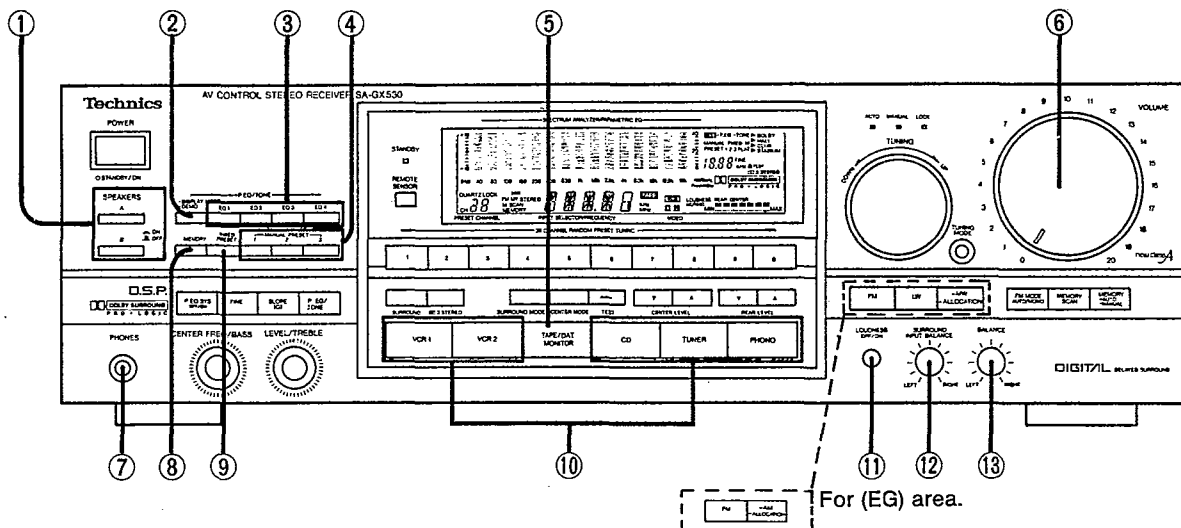

Amplifier section

- ① **Speaker selectors (SPEAKERS)**
These selectors are used to select the speaker system(s) (A and/or B).
- ② **Display mode select button (-DISPLAY MODE, -DEMO)**
This button is used to select either the spectrum analysis level ("Bar-type display" or "Dot display") or equalization level display.
If the button is pressed for 3 seconds or more, this unit will start a demonstration mode for the parametric EQ system.
- ③ **Parametric EQ band select buttons**
These buttons are used to select the band to be adjusted.
- ④ **Equalization preset buttons (MANUAL PRESET)**
These buttons are used for storing or recalling the curves made by the parametric EQ system.
- ⑤ **Tape-monitor button (TAPE/DAT MONITOR)**
Press this button to listen to a tape or a digital audio tape connected to the "TAPE/DAT" terminals.
To listen to some other source, press this switch once again (so that the indicator is switched OFF).
- ⑥ **Volume control (VOLUME)**
- ⑦ **Headphones jack (PHONES)**
- ⑧ **Parametric EQ system memory button (MEMORY)**
This button enables the curves to be stored in the parametric EQ system memory.
- ⑨ **Fixed preset button (FIXED PRESET)**
This button is used to recall a "fixed preset" curve from the main unit's memory.
- ⑩ **Input selector buttons**
These buttons are used to select the sound source to be heard, such as a disc, radio broadcasts, etc. The selected sound source is shown on the input selector/frequency display.
The "PHONO" input selector has two functions: when pressed momentarily it selects "PHONO". When pressed and held for about 4 seconds, it de-activates the muting function.
- ⑪ **Loudness button (LOUDNESS)**
Set to the "ON" position (the loudness indicator will illuminate); when listening to music at low volume. Auditory perception of sound in the low frequency range falls off at low volume, but when the switch is in this position, this deficiency is compensated for, so that the full impact of the musical performance can be enjoyed.
- ⑫ **Dolby Pro-Logic Surround input balance control (SURROUND INPUT BALANCE)**
This control is used to adjust the left/right balance of the sound from the playback source if the sound is not balanced when listening to the Dolby Pro-Logic Surround system.
- ⑬ **Balance control (BALANCE)**

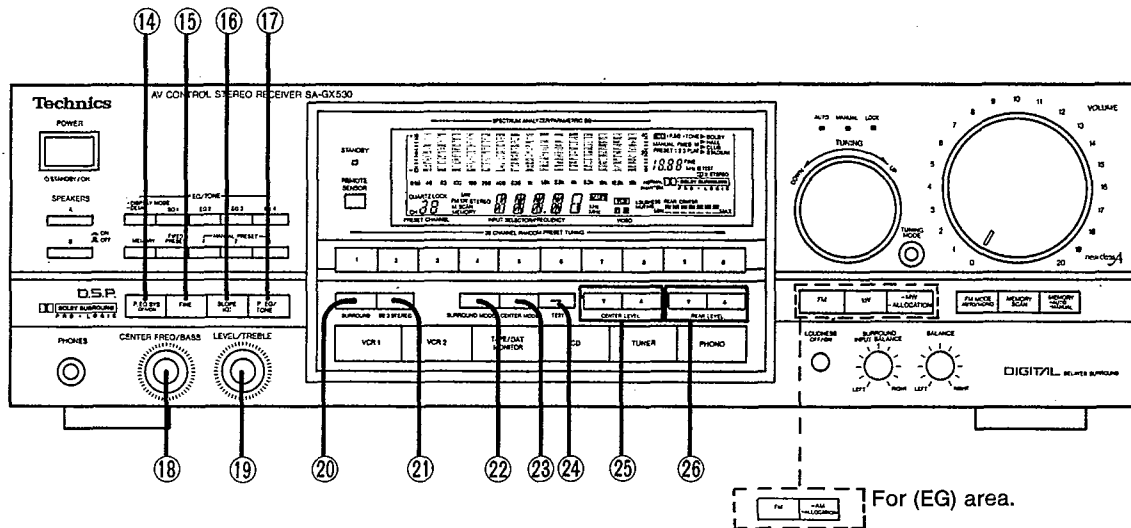

14 Parametric EQ system ON/OFF button (P.EQ SYS)

This button is used to turn the parametric EQ system ON or OFF.

15 Fine mode select button (FINE)

This button is used to fine-adjust the center frequency of the parametric EQ.

16 Slope changeover button [SLOPE (Q)]

This button is used to select the slope ("narrow" or "wide") of the parametric EQ curves.

17 Parametric EQ/tone mode select button (P.EQ/TONE)

This button is used to select parametric EQ mode or tone mode.

18 Center frequency select/bass control (CENTER FREQ/BASS)

This control is used to select the center frequency in the parametric EQ mode or to adjust the low-frequency sounds in the tone mode.

19 Frequency level/treble control (LEVEL/TREBLE)

This control is used to adjust the frequency level in the parametric EQ mode or the high-frequency sounds in the tone mode.

20 Surround ON/OFF button (SURROUND)

This button is used to activate the surround system.

21 Dolby 3 stereo ON/OFF button (3 STEREO)

This button is used to activate the Dolby 3 stereo effect.

22 Surround mode select button (SURROUND MODE)

This button is used to select the desired surround mode.

23 Center mode select button (CENTER MODE)

When the Dolby Pro-Logic Surround system is turned on, the center mode will change as follows each time you press this button: NORMAL → PHANTOM → (OFF):



24 Test signal button (TEST)

This button is used to output the test signal for adjusting the volume balance of the center and/or rear speakers when Dolby Pro-Logic Surround or Dolby 3 stereo mode is selected.

25 Center speaker level adjustment buttons (CENTER LEVEL)

These buttons are used to adjust the volume level of the center speaker.

26 Rear speaker level adjustment buttons (REAR LEVEL)

These buttons are used to adjust the volume level of the rear speakers.

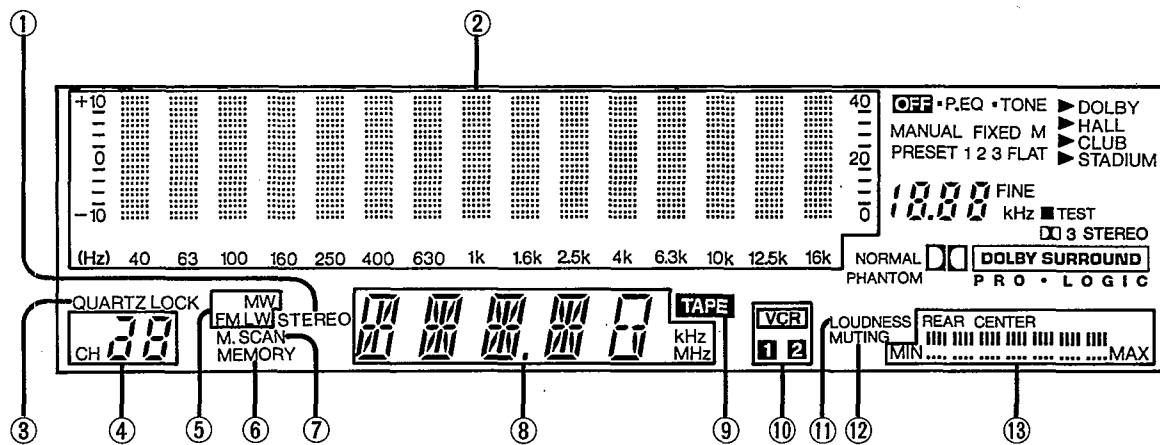

Display section

- ① **FM stereo indicator (STEREO)**
This indicator automatically illuminates when an FM stereo broadcast is being received.
Note:
It will not illuminate if the FM mode selector is set to the monaural mode.
- ② **Spectrum analysis/parametric EQ level display (SPECTRUM ANALYZER/PARAMETRIC EQ)**
This display shows the spectrum analysis level ("Bar-type display" or "Dot display") or equalization level.
- ③ **Quartz-lock indicator (QUARTZ LOCK)**
This indicator illuminates when the unit is tuned precisely to a broadcast station.
- ④ **Channel display**
This display shows the channel number selected by the preset-tuning button(s).
Also this display shows the channel number for about 3 seconds during memory scan operation.
- ⑤ **Band indicators (FM, LW, MW)**
Indicates the selected band.
- ⑥ **Memory indicator (MEMORY)**
This indicator illuminates when the memory button is pressed.
- ⑦ **Memory scan indicator (M. SCAN)**
This indicator illuminates when the memory scan button is pressed.
- ⑧ **Input selector/frequency display (INPUT SELECTOR/FREQUENCY)**
Displays the selected source or broadcast frequency.
- ⑨ **Tape indicator (TAPE)**
This indicator illuminates when the tape-monitor button is pressed.
- ⑩ **VCR display (VCR)**
Displays the selected VCR.
- ⑪ **Loudness indicator (LOUDNESS)**
This indicator illuminates when the loudness button is pressed.
- ⑫ **Muting indicator (MUTING)**
This indicator illuminates when the muting button (on the remote control transmitter) is pressed.
- ⑬ **Rear/center level indicator**
Displays the level adjusted by the center speaker level adjustment buttons or rear speaker level adjustment buttons.

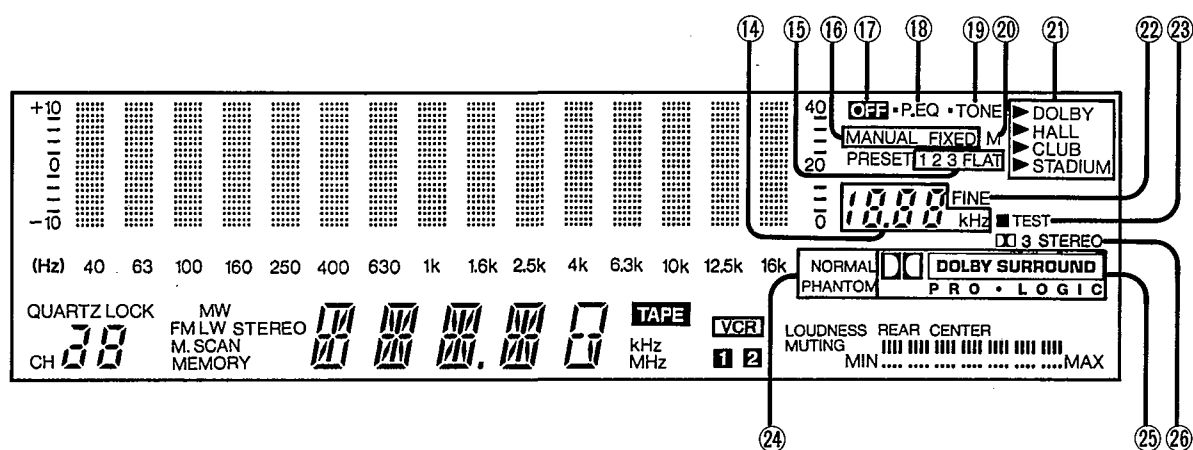

⑭ Parametric EQ system center frequency display

It displays the center frequency of the curves in the parametric EQ mode arranged by the user with the parametric EQ system or the curves pre-programmed in this unit's memory.

⑮ Manual/fixed preset indicators (1 2 3 FLAT)

It displays the type of curve selected with the equalization preset buttons or fixed preset button in the parametric EQ mode.

⑯ Parametric EQ system operation select indicators (MANUAL/FIXED)

One of these indicators illuminates in accordance with the fixed preset button or equalization preset buttons setting.

⑰ Parametric EQ system off indicator (OFF)

This indicator illuminates when the parametric EQ system is off.

⑱ Parametric EQ mode indicator (P.EQ)

This indicator illuminates when the parametric EQ/tone mode select button is set to the parametric EQ mode.

⑲ Tone mode indicator (TONE)

This indicator illuminates when the parametric EQ/tone mode select button is set to the tone mode.

⑳ Parametric EQ system memory indicator (M)

This indicator illuminates when the parametric EQ system memory button is pressed in the parametric EQ mode.

㉑ Surround mode display

This display shows the surround mode selected by the surround mode select button.

㉒ Fine mode indicator (FINE)

This indicator illuminates when the fine mode select button is pressed in the parametric EQ mode.

㉓ Test signal indicator (TEST)

This indicator illuminates when the test signal button is pressed in the Dolby Pro-Logic Surround mode and the Dolby 3 stereo mode.

㉔ Center mode indicators (NORMAL/PHANTOM)

These indicators show the center mode selected by the center mode select button.

㉕ Dolby Pro-Logic Surround indicator (DOLBY SURROUND, PRO-LOGIC)

This indicator illuminates when the Dolby Pro-Logic Surround mode is selected.

㉖ Dolby 3 stereo indicator (3 STEREO)

This indicator illuminates when the Dolby 3 stereo ON/OFF button is switched ON.

REMOTE CONTROL OPERATION

- This remote control transmitter can be used for control of a Technics cassette tape deck or a compact disc player with a remote control terminal.
- Consult your dealer for details.
- For detailed information concerning operation steps, etc., please refer to the appropriate page for each unit and the respective operating instructions.
- For this system, you can listen to tapes or compact discs, etc., by operating the remote control transmitter without using this unit's input selector buttons.
- Make sure that the power of each unit is set to the "ON" position, before beginning the operations.

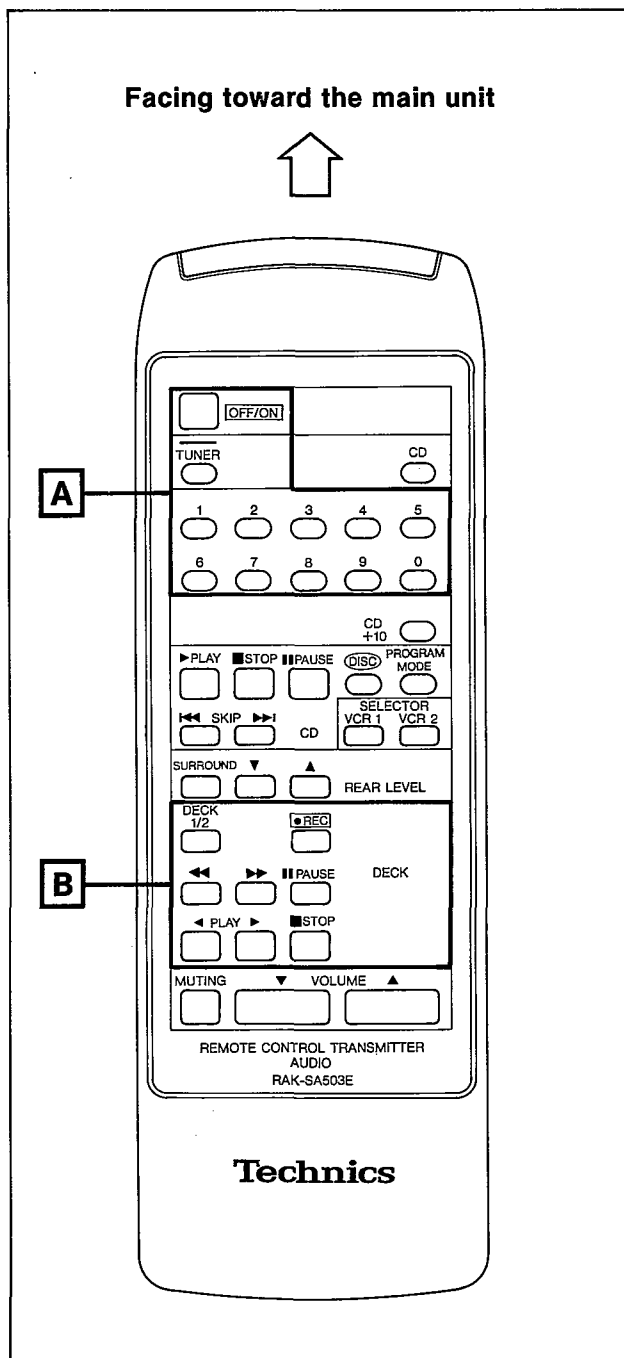

A Tuner controls

TUNER

Press this button first to use the "OFF/ON" button or the **1** - **0** buttons.

OFF/ON

This button can be used for ON and OFF switching of this unit. When switching the power ON and OFF, be sure to first press the "TUNER" button.

1 - **0**

Press these buttons to select the desired preset channel. When these buttons are used, be sure to first press the "TUNER" button.

To designate channels 1-9:

Press the appropriate numeric button (1-9).

Note: When selecting channel 1, 2 or 3 enter the selection "01", "02" or "03". If only "1", "2" or "3" is pressed, channel access will be delayed by two seconds.

To designate channels 10-30:

① Press the button for the "tens" digit (1, 2 or 3).

② Press the button for the "units" digit (1-0) within 2 seconds after pressing the first button.

Note:

If the interval between pressing the first button and pressing the second button is more than about 2 seconds, the setting may not be made correctly. If this happens, make the setting once again.

B Tape deck controls

DECK 1/2

Press this button to select the deck ("DECK 1" or "DECK 2") to be controlled.

REC

Press this button to change to the recording stand-by mode.

◀▶

Press one of these buttons to advance or rewind the tape while the unit is in the stop mode.

Press one of these buttons to select the desired tune while the unit is in the play mode. (Only applicable to a Technics tape deck with the "music select" functions.)

|| PAUSE

Press this button to temporarily stop playback or recording.

Press the playback button to resume the playback or recording.

◀▶ PLAY ▶

Press one of these buttons to begin playback or recording, pressing the button corresponding to the side of the tape to be played back (or recorded).

▶ : For the "forward (A)" side of the tape

◀ : For the "reverse (B)" side of the tape

Note:

Depending on which Technics tape deck is used in combination with this unit, tape deck 1 might be the "A"-side playback-only type.

■ STOP

Press this button to stop tape movement.

Note

Depending on which Technics tape deck is used in combination with this unit, the pause of the playback (and the recording), and the recording functions of tape deck 1 might not be possible.

Facing toward the main unit

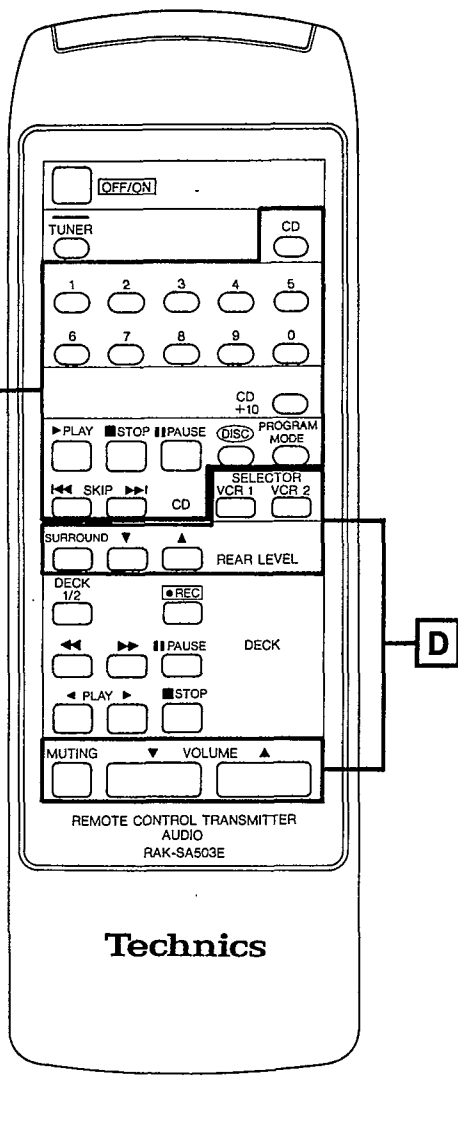

C Compact disc player controls

CD

Press this button first to use the **1** - **+10** buttons.

1 - **+10**

Press these buttons to select the desired track.

Playback begins from the track selected.

When these buttons are used, be sure to first press the "CD" button.

Tracks 1-9:

Press the appropriate numeric button (**1** - **9**) directly.

To select a two-digit track number over 10:

Press the (**+10**) button the necessary number of times to select the "tens" digit, and then one of the (**1** - **9**) buttons to select the "units" digit.

▶ PLAY

Press this button to start play.

■ STOP

Press this button to stop play.

|| PAUSE

Press this button to temporarily stop play.

Press the play button to resume play.

DISC

If a Technics multi compact disc player is used in combination with this unit, the disc to be played can be selected by first pressing this button and then pressing the appropriate numeric button (**1** - **5**).

PROGRAM MODE

Press this button to select the desired play mode.

("PROGRAM" or "CONTINUE")

◀◀ SKIP ▶▶

Press one of these buttons briefly to move the pick-up to the beginning of a specific track.

Note:

When operating a compact disc player with a remote control sensor, face this remote control transmitter toward the remote control sensor of the compact disc player.

D Amplifier controls

SELECTOR

Press one of these buttons to switch this unit's input selector "VCR 1" or "VCR 2".

SURROUND

Press this button to switch the surround effect ON/OFF.

REAR LEVEL

Adjust the volume level of the rear speakers as desired.

MUTING

Press this button to temporarily reduce the volume level.

The volume level is attenuated by 20 dB (approx. 1/10).

Press once again to return to the previous volume level.

▼ VOLUME ▲

Press one of these buttons to adjust the volume level.

MUTUAL OPERATIONS

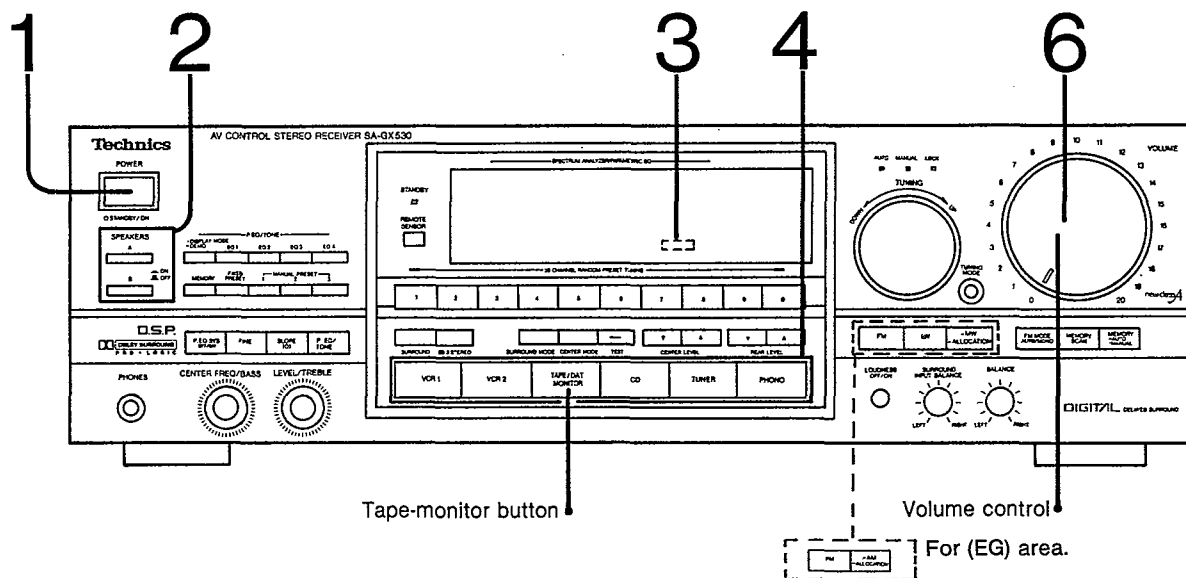

Before operation, set the volume control to the "0" position.

1 Set the power switch to ON.

2 Select the "A" and/or "B" speaker system(s) to be used.

3 Check to be sure the tape indicator is not illuminated.

To listen to sources other than a tape be sure to turn off the tape indicator.

If the tape indicator is illuminated:

Press the tape-monitor button.

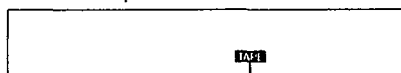

Tape indicator

4 Select the audio or video source.
VCR 1: Press to watch video tapes from the VCR connected to the "VCR 1" terminals.

VCR 2: Press to watch video tapes from the VCR or video discs from the laser disc player connected to the "VCR 2" terminals.

TAPE/DAT MONITOR: Press to listen to tape or DAT. (The tape indicator will illuminate.)

When listening to tapes is finished, be sure to press the tape-monitor button to turn off the tape indicator.

CD: Press to listen to compact discs.

TUNER: Press to listen to radio broadcasts.

PHONO: Press to listen to phono discs.

Note:

It is recommended that the power to the compact disc player should be switched OFF when it is not being used.

5 Start the audio or video source.
 (Refer to the appropriate operating instructions for details).

6 Adjust the volume level.

After listening is finished

Be sure to reduce the volume level, and switch the power to standby mode from the remote control transmitter or by the power "⊖ STANDBY/ON" switch of this unit.

Note: The input selection, sound mode, loudness and the muting settings will be retained (as they were at the time when the power was switched to standby mode) by the memory back-up function.

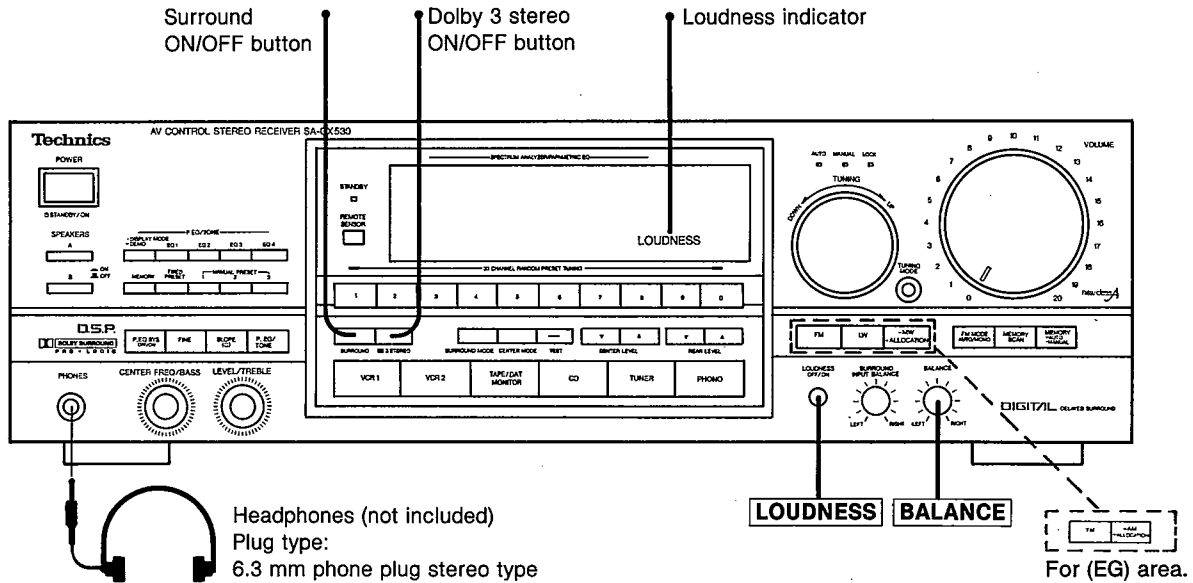

To listen to a desired audio source while watching video picture

1. Follow steps 1–3 at the left.
2. Select the desired video source and audio source in step 4 at the left.
Be sure to select the video source first.
3. Start the video and audio source.

When listening through headphones

- Use the volume control to reduce the volume level, and connect the headphones to the headphones jack.
- If sound from the speakers is not wanted, set the speaker selectors ("SPEAKERS") to the "OFF" position.
- Set the Dolby 3 stereo ON/OFF button and surround ON/OFF button to OFF when the center speaker and/or rear speakers are connected.
- Avoid listening for prolonged periods of time to prevent hearing damage.

To emphasize low-frequency sound

LOUDNESS

Set the loudness button to "ON" position.

The loudness indicator will illuminate.
(Refer to item ⑩ on page 8.)

To adjust the left/right sound balance

BALANCE

Adjust the balance control.

DISASSEMBLY INSTRUCTIONS

"ATTENTION SERVICER"

Some chassis components may have sharp edges. Be careful when disassembling and servicing.

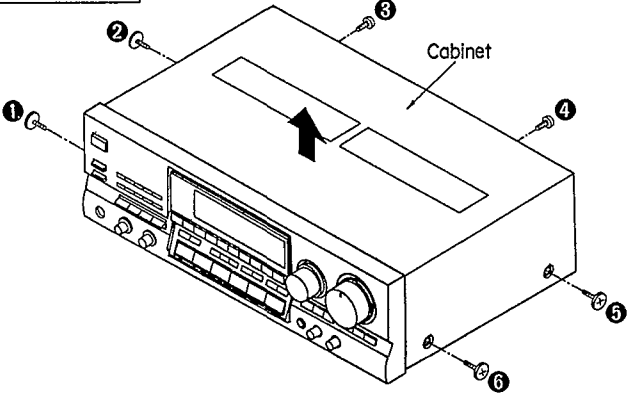
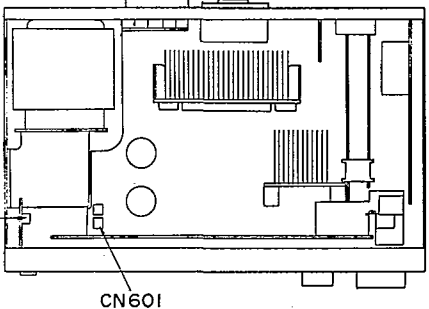
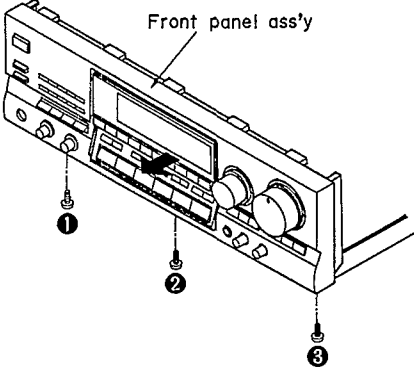
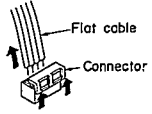
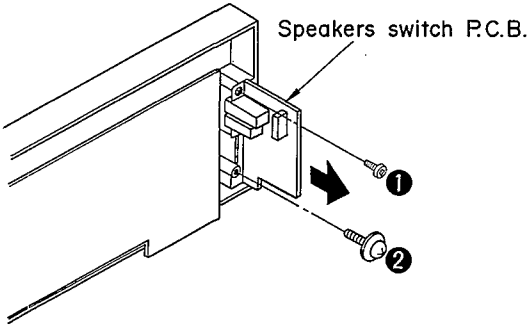
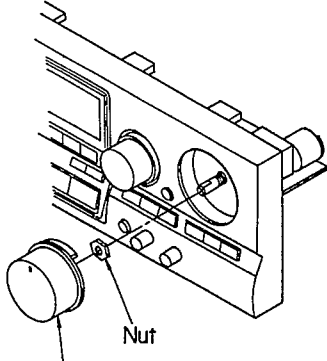
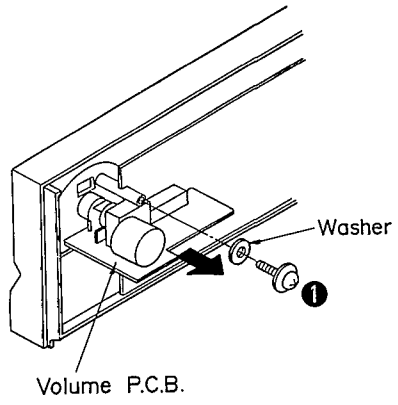
Ref. No. 1	Removal of the cabinet	Ref. No. 2	Removal of the front panel ass'y
Procedure 1	 <p>• Remove the 6 screws (①~⑥).</p>	Procedure 1→2	<p>1. Remove the 2 flat cables (CN601, CN602).</p>  <p>2. Remove the 3 screws (①~③).</p> <p>3. Remove the front panel ass'y in the direction of arrow.</p> 
Ref. No. 3	Removal of the speakers switch P.C.B.	Removal of the flat cable <p>1. Lift the connector.</p> <p>2. Pull out the flat cable.</p> 	
Procedure 1→2→3	 <p>• Remove the 2 screws (①, ②).</p>	Ref. No. 4	
Procedure 1→2→4	 <p>1. Pull out the volume knob.</p> <p>2. Remove the nut.</p>	 <p>3. Remove the 1 screw (①) and the washer.</p> <p>4. Remove the volume P.C.B. in the direction of arrow.</p>	

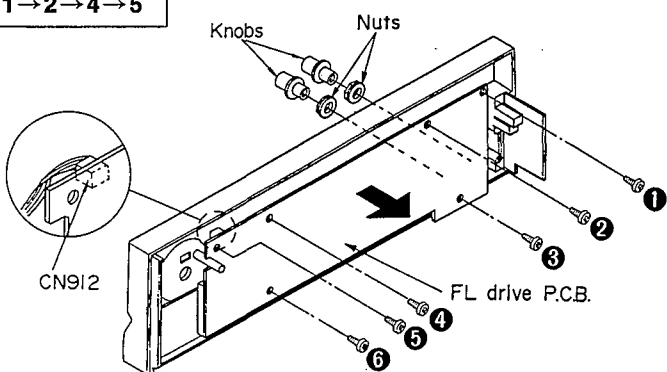
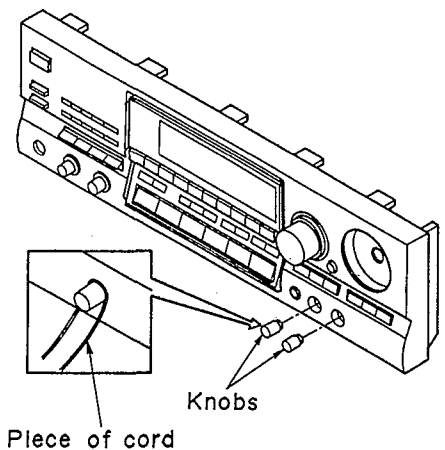
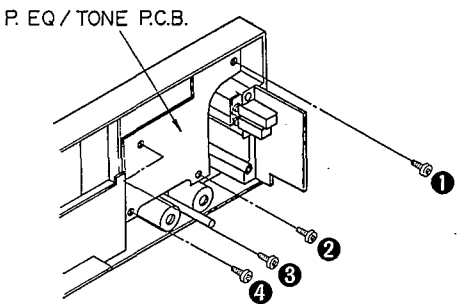
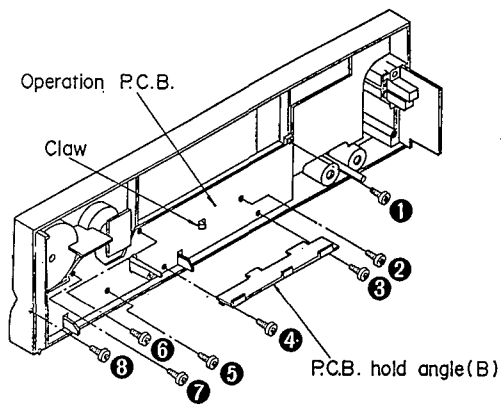
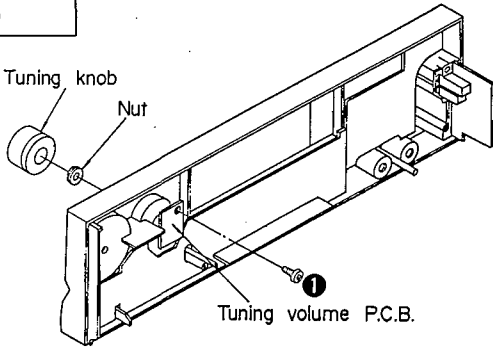
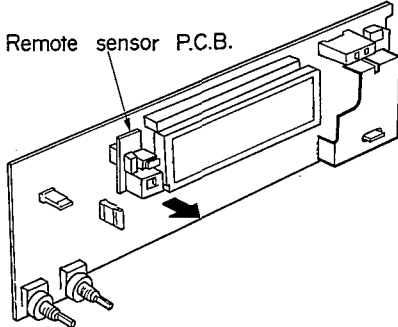
Ref. No. 5	Removal of the FL drive P.C.B.	Ref. No. 6	Removal of the operation P.C.B.
Procedure 1→2→4→5	 <ol style="list-style-type: none"> 1. Remove the 2 knobs. 2. Remove the 2 nuts. 3. Remove the 6 screws (①~⑥). 4. Remove the FL drive P.C.B. in the direction of arrow. 5. Remove the 1 flat cable (CN912). 	Procedure 1→2→4→5 →6	 <p>※ If the knob is difficult to remove, wrap a piece of cord or something similar around it to remove it.</p> <ol style="list-style-type: none"> 1. Remove the 2 knobs.
Ref. No. 7	Removal of the P. EQ/TONE P.C.B.	Ref. No. 9	Removal of the remote sensor P.C.B.
Procedure 1→2→4→5 →7	 <p>• Remove the 4 screws (①~④).</p>	Procedure 1→2→4→5 →6	 <ol style="list-style-type: none"> 2. Remove the 8 screws (①~⑧). 3. Remove the P.C.B. hold angle (B). 4. Release the 1 claw.
Ref. No. 8	Removal of the tuning volume P.C.B.	Ref. No. 9	Removal of the remote sensor P.C.B.
Procedure 1→2→4→5 →8	 <ol style="list-style-type: none"> 1. Pull out the tuning knob. 2. Remove the nut. 3. Remove the 1 screw (①). 	Procedure 1→2→4→5 →9	 <p>• Remove the remote sensor P.C.B. in the direction of arrow.</p>

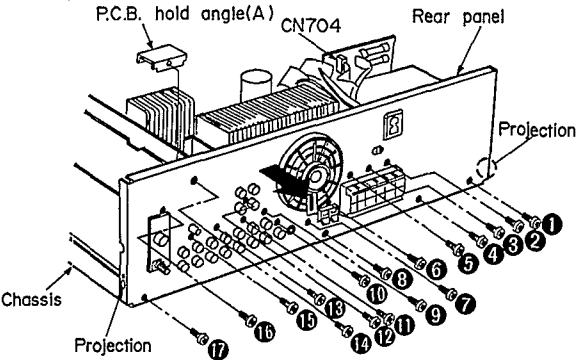
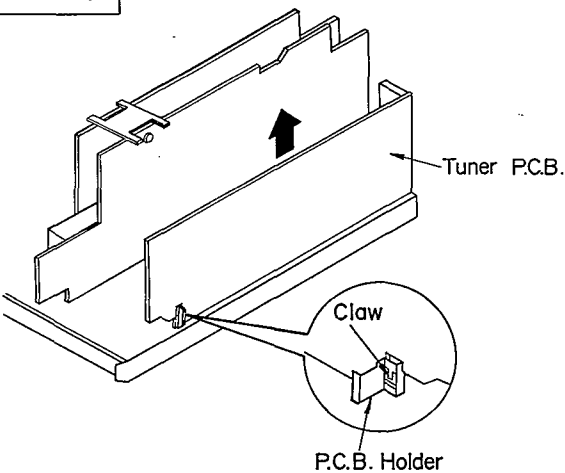
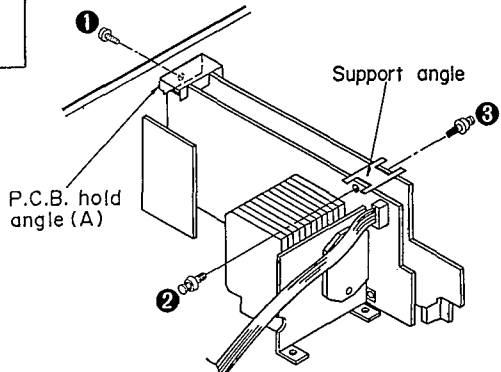
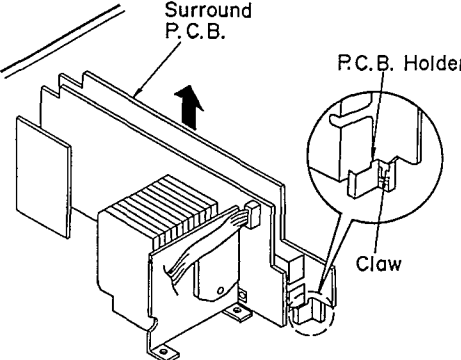
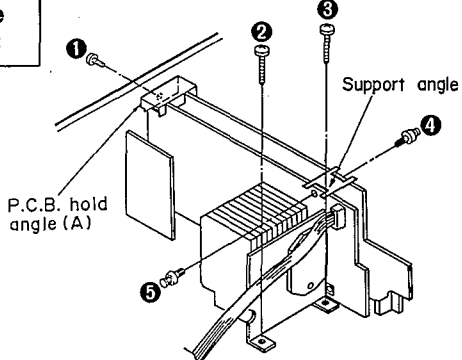
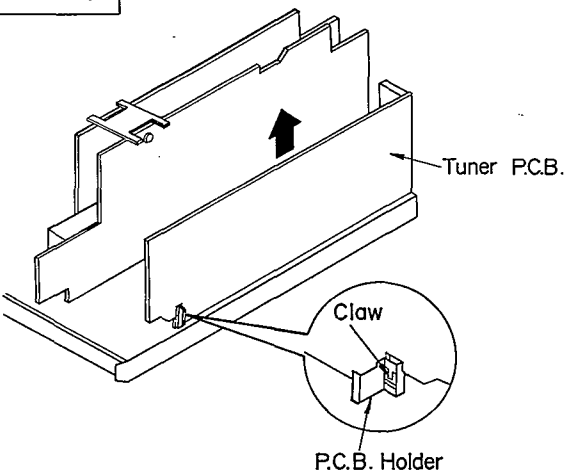
<p>Ref. No. 10</p>	<p>Removal of the rear panel</p>	<p>Ref. No. 11</p>	<p>Removal of the tuner P.C.B.</p>
<p>Procedure 1→10</p>	 <ol style="list-style-type: none"> 1. Remove the 1 flat cable (CN704). 2. Remove the 17 screws (①~⑰). 3. Remove the P.C.B. hold angle (A). 4. Remove the rear panel from the projection of the chassis. 		<p>Procedure 1→2→10→11</p>
<p>Ref. No. 12</p>	<p>Removal of the surround P.C.B.</p>	 <ol style="list-style-type: none"> 1. Release the 1 claw. 2. Remove the tuner P.C.B. in the direction of arrow. 	
<p>Procedure 1→2→12</p>	 <ol style="list-style-type: none"> 1. Remove the 1 screw (①). 2. Remove the P.C.B. hold angle (A). 3. Remove the 2 latches (②, ③). 4. Remove the support angle. 		 <ol style="list-style-type: none"> 5. Release the 1 claw. 6. Remove the surround P.C.B. in the direction of arrow.
<p>Ref. No. 13</p>	<p>Removal of the parametric EQ P.C.B.</p>	  <ol style="list-style-type: none"> 5. Remove the 1 flat cable (CN703). 6. Remove the parametric EQ P.C.B. in the direction of arrow. 	
<p>Procedure 1→2→13</p>	<ol style="list-style-type: none"> 1. Remove the 3 screws (①~③). 2. Remove the P.C.B. hold angle (A). 3. Remove the 2 latches (④, ⑤). 4. Remove the support angle. 		

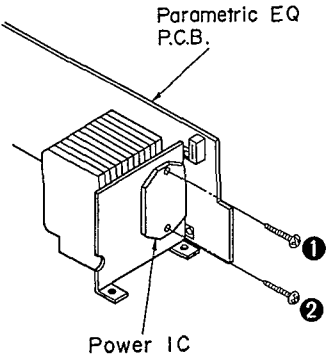
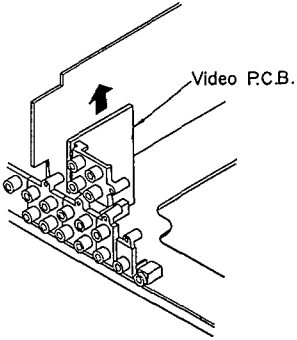
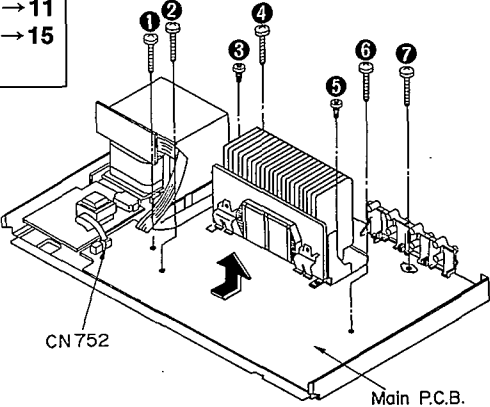
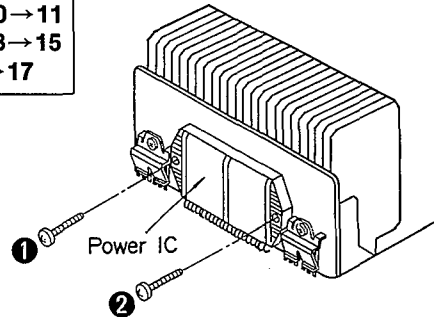
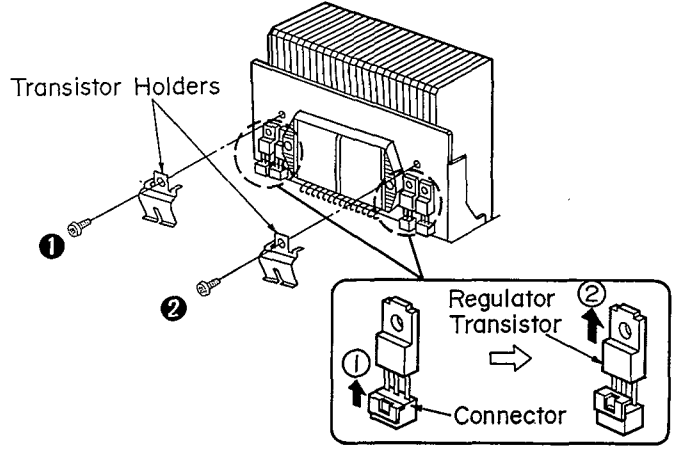
Ref. No. 14	Removal of the power IC	Ref. No. 15	Removal of the video P.C.B.
Procedure 1→2→13→14	 <ol style="list-style-type: none"> 1. Unsolder the power IC. 2. Remove the 2 screws (①, ②). <ul style="list-style-type: none"> • When mounting the power IC, apply silicon thermal compound (RFKX0002 or equivalent) to the rear of the power IC. 	Procedure 1→2→10→15	 <ul style="list-style-type: none"> • Remove the video P.C.B. in the direction of arrow.
Ref. No. 16	Removal of the main P.C.B.	Ref. No. 17	Removal of the power IC
Procedure 1→2→10→11 →12→13→15 →16	 <ol style="list-style-type: none"> 1. Remove the 1 flat cable (CN752). 2. Remove the 7 screws (①~⑦). 3. Remove the main P.C.B. in the direction of arrow. 	Procedure 1→2→10→11 →12→13→15 →16→17	 <ol style="list-style-type: none"> 1. Unsolder the power IC. 2. Remove the 2 screws (①, ②). <ul style="list-style-type: none"> • When mounting the power IC, Apply silicone compound (RFKX0002) to the rear side of power IC.
Ref. No. 18	Removal of the regulator transistor		
Procedure 1→2→13→18	 <ol style="list-style-type: none"> 1. Remove the 2 screws (①, ②). 2. Remove the 2 transistor holders. 3. Lift up the connector in the direction of arrow ①. 4. Remove the regulator transistor in the direction of arrow ②. <ul style="list-style-type: none"> • When mounting the regulator transistor, Apply silicone compound (RFKX0002) to the rear side of power IC. 		

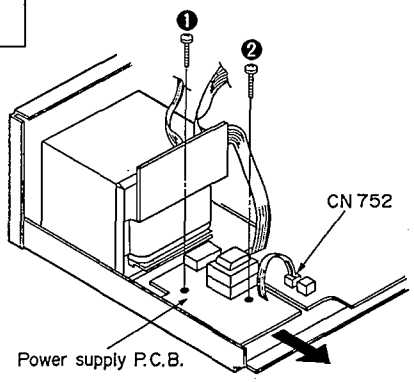
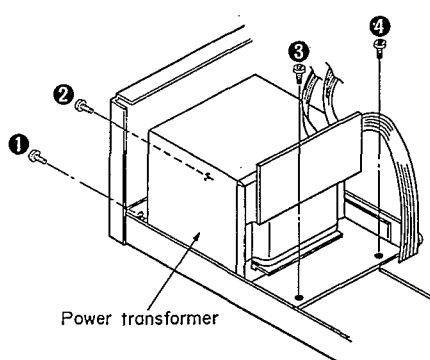
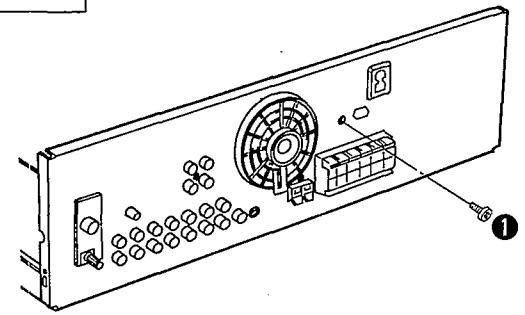
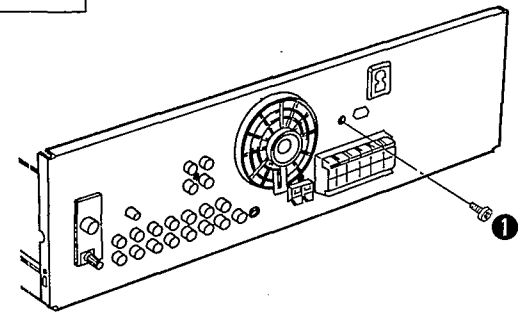
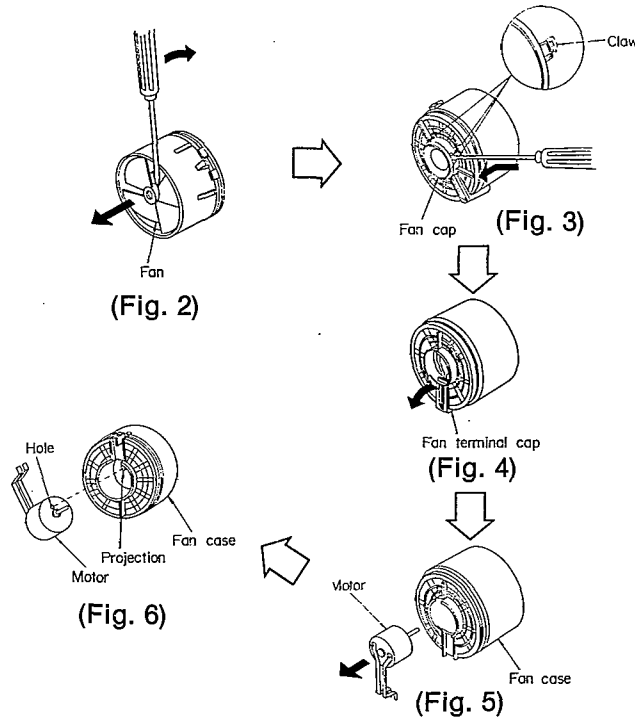
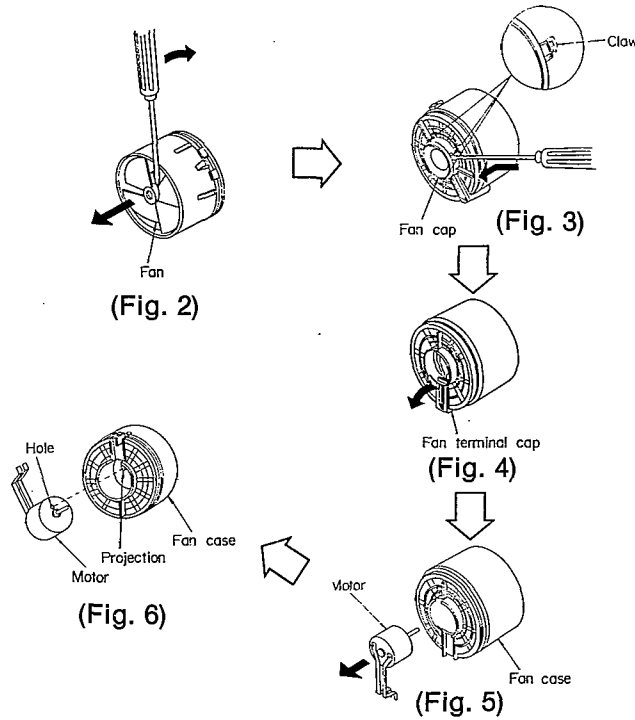
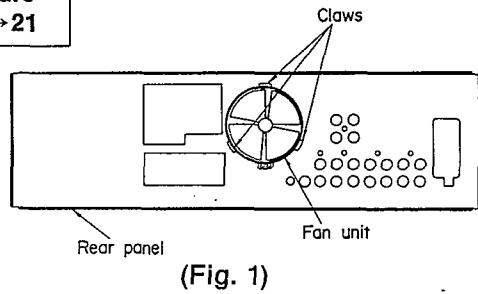
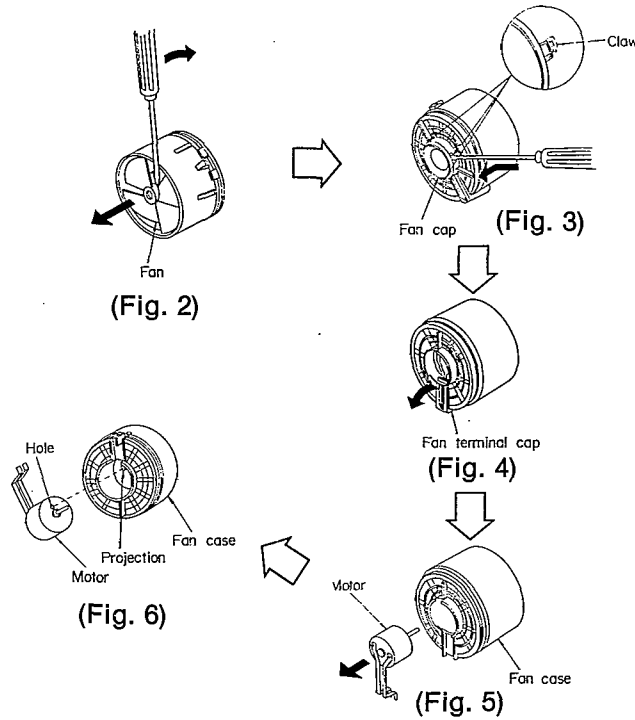
<p>Ref. No. 18</p>	<p>Removal of the power supply P.C.B.</p>	<p>Ref. No. 19</p>	<p>Removal of the power transformer</p>
<p>Procedure 1→2→18</p>	 <p>1. Remove the 1 flat cable (CN752). 2. Remove the 2 screws (①, ②). 3. Remove the power supply P.C.B. in the direction of arrow.</p>	<p>Procedure 1→2→18→19</p>	 <p>• Remove the 4 screws (①~④).</p>
<p>Ref. No. 20</p>	<p>Removal of the AC IN P.C.B.</p>	 <p>1. Remove the 1 screw (①). 2. Release the 2 claws.</p>	
<p>Procedure 1→10→20</p>	 <p>1. Remove the 1 screw (①). 2. Release the 2 claws.</p>	 <p>1. Remove the 1 screw (①). 2. Release the 2 claws.</p>	
<p>Ref. No. 21</p>	<p>Removal of the cooling fan motor</p>	 <p>1. Release the 3 claws. (See Fig. 1) 2. Insert a screwdriver at the root of the fan. Force it out of the motor shaft. (See Fig. 2) 3. Remove the fan cap by used ⊖ screwdriver. (See Fig. 3) 4. Remove the fan terminal cap in the direction of arrow. (See Fig. 4). 5. Remove the motor from the fan case. (See Fig. 5). 6. When mounting the motor, align the fan casing's projection with the hole of the motor. (See Fig. 6).</p>	
<p>Procedure 1→10→21</p>	 <p>1. Release the 3 claws. (See Fig. 1) 2. Insert a screwdriver at the root of the fan. Force it out of the motor shaft. (See Fig. 2) 3. Remove the fan cap by used ⊖ screwdriver. (See Fig. 3) 4. Remove the fan terminal cap in the direction of arrow. (See Fig. 4). 5. Remove the motor from the fan case. (See Fig. 5). 6. When mounting the motor, align the fan casing's projection with the hole of the motor. (See Fig. 6).</p>	 <p>1. Release the 3 claws. (See Fig. 1) 2. Insert a screwdriver at the root of the fan. Force it out of the motor shaft. (See Fig. 2) 3. Remove the fan cap by used ⊖ screwdriver. (See Fig. 3) 4. Remove the fan terminal cap in the direction of arrow. (See Fig. 4). 5. Remove the motor from the fan case. (See Fig. 5). 6. When mounting the motor, align the fan casing's projection with the hole of the motor. (See Fig. 6).</p>	

BLOCK DIAGRAM

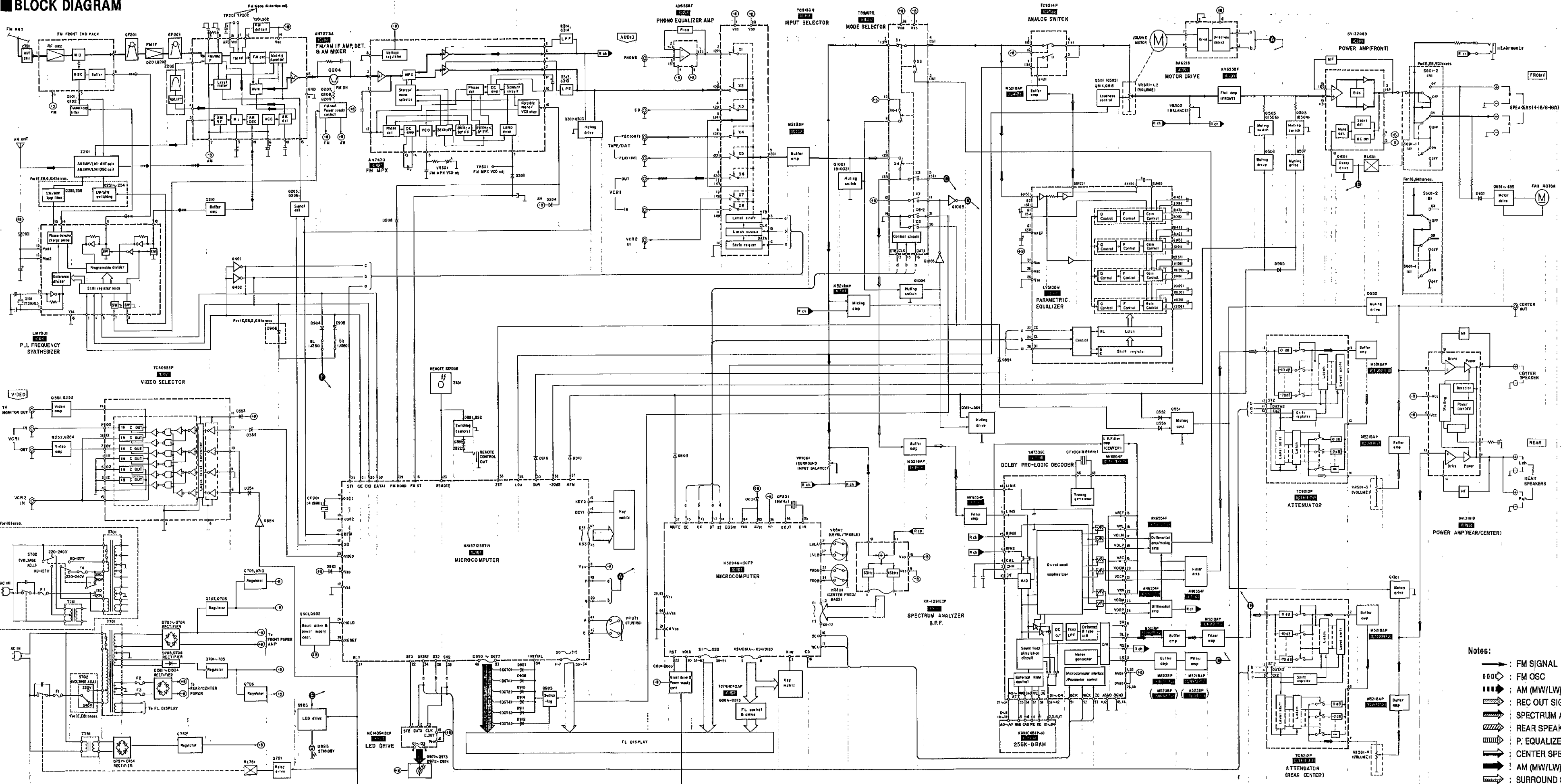

TERMINAL GUIDE OF IC'S, TRANSISTORS AND DIODES

M5218AP 	M5238P 8 Pin XR-1091ECP 16 Pin 	AN6554F 14 Pin LM7001 16 Pin 	AN6558F 8 Pin AN7470 16 Pin MC14094BCP 16 Pin AN7273A 18 Pin KM41C464P-10 18 Pin
TC4053BP 16 Pin TC74HC42AP 16 Pin TC8214P 16 Pin TC8212P 20 Pin TC9163N 28 Pin 	TC9162N 28 Pin 	YM7306C 64 Pin M5094G-150FP 72 Pin 	
LV3100M 	MN187125STV1 	SV13101D 	SV13206D BA8219
MN1381STA 	2SA92EFTA 2SA1015Y0GTA 2SB821AQRSTA 2SC2831QRSTA 	2SA1309AGSTA 2SC2785FETA 2SC2787LTA 2SC311AORSTA 2SD1450QRSTA UN411TA 	UN4113TA UN4115TA UN4211TA UN4214TA UN4215TA DTC114E8TP
2SC3940AQSTA 	2SA933QRSTA 2SC1740SQSTA 	2SC3327ABTP 	2SJ40CDA 2SB187DEF 2SD176ZDEF
P300DLF GP16GLF 	MA29WATA MA185TA MA700ATA 1SS291TA 1SR3520TB MA723TA 	MA4038MTA MA4039MTA MA4051MTA MA4052MTA MA4058MTA MA4062MTA 	
MA4330MTA 	LN018304P 	LN031527PH 	

- Notes:
- FM SIGNAL
 - ◻ FM OSC
 - ▨ AM (MW/LW) OSC
 - ▧ REC OUT SIGNAL (Lch)
 - ▩ SPECTRUM ANALYZER SIGNAL (Lch)
 - REAR SPEAKER DRIVE SIGNAL (Lch)
 - P. EQUALIZER SIGNAL (Lch)
 - ▬ CENTER SPEAKER DRIVE SIGNAL (Lch)
 - ▮ AM (MW/LW) SIGNAL
 - ▯ SURROUND SIGNAL

SCHEMATIC DIAGRAM (This schematic diagram may be modified at any time) with the development of new technology.

(Parts list on pages 66~69, 73~76.)

Note 1:

- S601 : Speaker selectors (SPEAKERS) switches. [S601-1: A, S601-2: B]
- S702 : Voltage adjustment switch.
- S801 : Display mode select (-DISPLAY MODE, -DEMO) switch.
- S802~805: Parametric EQ band switches. [S802: EQ1, S803: EQ2, S804: EQ3] [S805: EQ4]
- S806 : Parametric EQ system ON/OFF (P. EQ SYS) switch.
- S807 : Fine mode (FINE) switch.
- S808 : Slope changeover [SLOPE (Q)] switch.
- S809 : Parametric EQ/tone mode select (P. EQ/TONE) switch.
- S810 : Parametric EQ system memory (MEMORY) switch.
- S811 : Fixed preset (FIXED PRESET) switch.
- S812~814: Equalization preset (MANUAL PRESET) switches. [S812: 1, S813: 2, S814: 3]
- S815 : Surround mode select (SURROUND MODE) switch.
- S817 : Center mode select (CENTER MODE) switch.
- S818 : Test signal (TEST) switch.
- S819 : Dolby 3 stereo ON/OFF (3 STEREO) switch.
- S901~910: Preset-tuning (1-0) (30 CHANNEL RANDOM PRESET TUNING) switches. [S901: 1, S902: 2, S903: 3, S904: 4, S905: 5, S906: 6, S907: 7, S908: 8, S909: 9, S910: 0]
- S911 : Dolby surround ON/OFF (SURROUND) switch.
- S912, 913 : Center speaker level adjustment (CENTER LEVEL) switches. [S912: ▽, S913: ▲]
- S914, 915 : Rear speaker level adjustment (REAR LEVEL) switches. [S914: ▽, S915: ▲]
- S916, 917, 921~923 : Input selector switches. [S916: PHONO, S917: TUNER, S921: VCR2] [S922: VCR1, S923: CD]
- S918 : Tape-monitor (TAPE/DAT MONITOR) switch.
- S925 : Loudness (LOUDNESS) switch.
- S926 : Tuning-mode selector (TUNING MODE) switch. [AUTO↔MANUAL↔LOCK]
- S927, 928 : Band selector switches. [S927: FM, S928: AM]
- S929 : FM mode selector (FM MODE) switch.
- S930 : Memory scan (MEMORY SCAN) switch.
- S931 : Memory (MEMORY) switch.
- S932 : Power "⊕ STANDBY/ON" switch.
- S933 : Band selector (LW) switch.

Important safety notice:

Components identified by Δ mark have special characteristics important for safety. When replacing any of these components, use only manufacturer's specified parts. Indicated voltage values are standard values for the unit measured by the DC electronic circuit tester (high-impedance) with the chassis taken as standard. Therefore, there may exist some errors in the voltage values, depending on internal impedance of the DC circuit tester.

All voltage values shown in circuitry are DC voltage in FM signal (Stereo signal) reception mode.

* Figures in () Stand for DC-voltage in AM (MW) signal reception mode.

* Figures in [] Stand for DC-voltage in LW signal reception mode.

The supply part number is described alone in the replacement parts list.

Ref. No.	Production Part No.	Supply Part No.
IC301	AN7470	SVIUPC1161C3
IC402, 1010, 1011	M5238P	M5238P-1
Z891	RCDHC-677-E	RCDHC-677

Caution!

- IC and LSI are sensitive to static electricity. Secondary trouble can be prevented by taking care during repair.
- Cover the parts boxes made of plastics with aluminum foil.
- Ground the soldering iron.
- Put a conductive mat on the work table.
- Do not touch the legs of IC or LSI with the fingers directly.

Note 2:

Use of ceramic filters in pairs

The ceramic filters (CF201, CF202) for FM-IF circuit are available in three ranks. For this circuit, be sure to use the ceramics of the same rank in a pair. At repairing and replacement, pay close attention to the short jumpers (J380, J381) for use as different short jumpers must be used depending on each rank of the ceramic filters.

Color marking

RANK (Color)	J381 (BL)	J380 (OR)	CENTER FREQUENCY
Blue	○	×	10.675MHz
Red	○	○	10.700MHz
Orange	×	○	10.725MHz

Note: ○ mark: short jumper is used.
× mark: short jumper is not used.

Signal line

- : FM OSC
- ▬▬▬▬: AM (MW/LW) OSC
- ▬▬▬▬: FM signal
- ▬▬▬▬: AM (MW/LW) signal
- ▬▬▬▬: Rec out signal (Lch)
- ▬▬▬▬: Spectrum analyzer signal (Lch)
- ▬▬▬▬: Rear speaker drive signal (Lch)
- ▬▬▬▬: P. equalizer signal (Lch)
- ▬▬▬▬: AF signal (Lch)
- ▬▬▬▬: Center speaker drive signal
- ▬▬▬▬: Surround signal
- ▬▬▬▬: Positive voltage lines
- - - - : Negative voltage lines

A TUNER CIRCUIT For [EG] area.

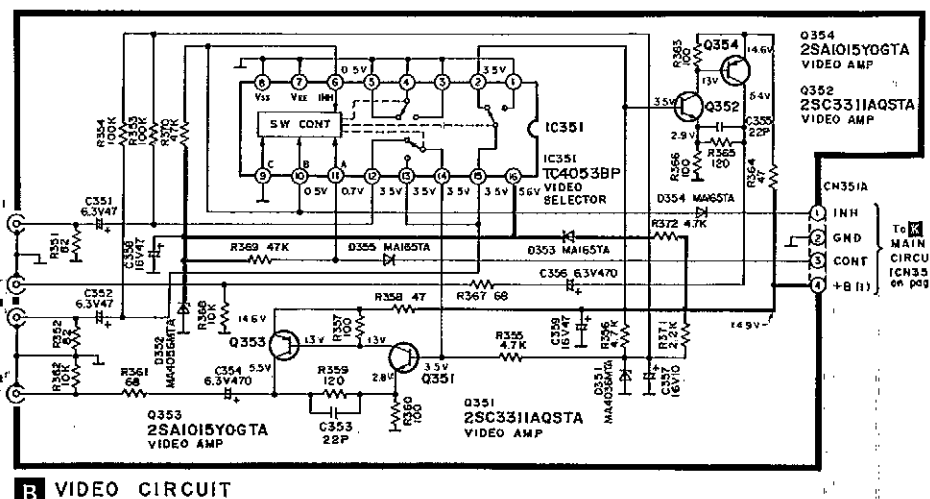
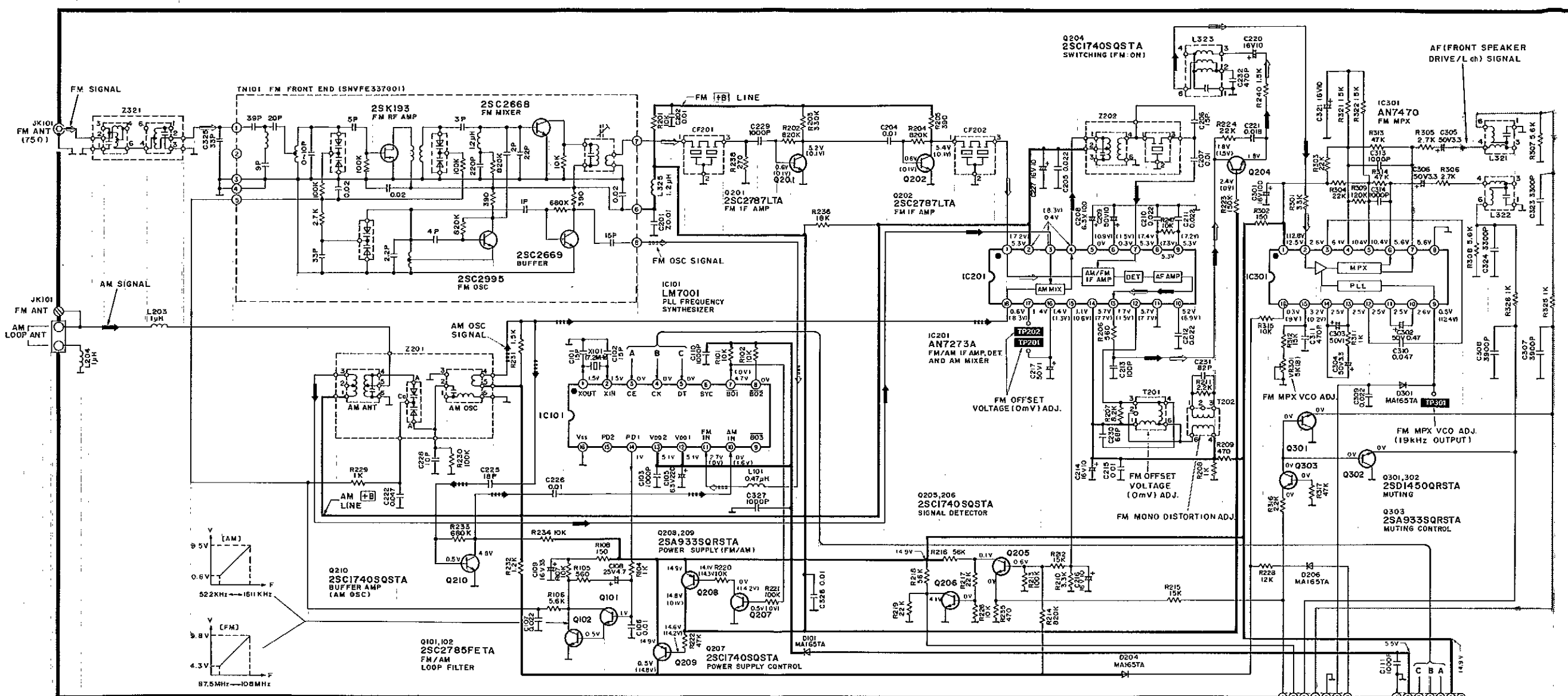

B VIDEO CIRCUIT

C SURROUND CIRCUIT

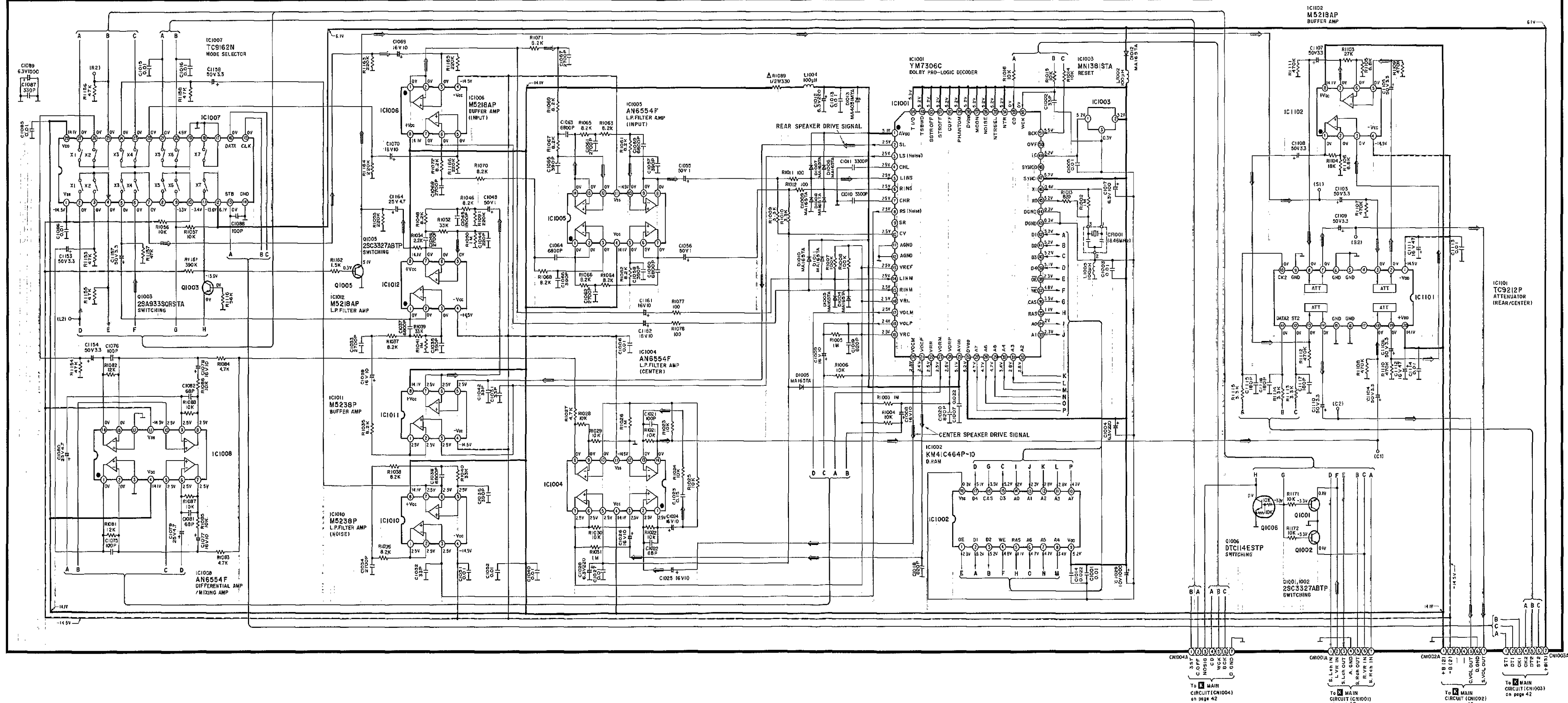

CN1004A
 1 2 3 4 5 6 7 8 9 10 11 12 13 14 15 16 17 18 19 20 21 22 23 24 25 26 27 28 29 30 31 32 33 34 35
 To MAIN CIRCUIT (CN1004) on page 42

CN1001A
 1 2 3 4 5 6 7 8 9 10 11 12 13 14 15 16 17 18 19 20 21 22 23 24 25 26 27 28 29 30 31 32 33 34 35
 To MAIN CIRCUIT (CN1001) on page 42

CN1002A
 1 2 3 4 5 6 7 8 9 10 11 12 13 14 15 16 17 18 19 20 21 22 23 24 25 26 27 28 29 30 31 32 33 34 35
 To MAIN CIRCUIT (CN1002) on page 42

CN1003A
 1 2 3 4 5 6 7 8 9 10 11 12 13 14 15 16 17 18 19 20 21 22 23 24 25 26 27 28 29 30 31 32 33 34 35
 To MAIN CIRCUIT (CN1003) on page 42

K MAIN CIRCUIT

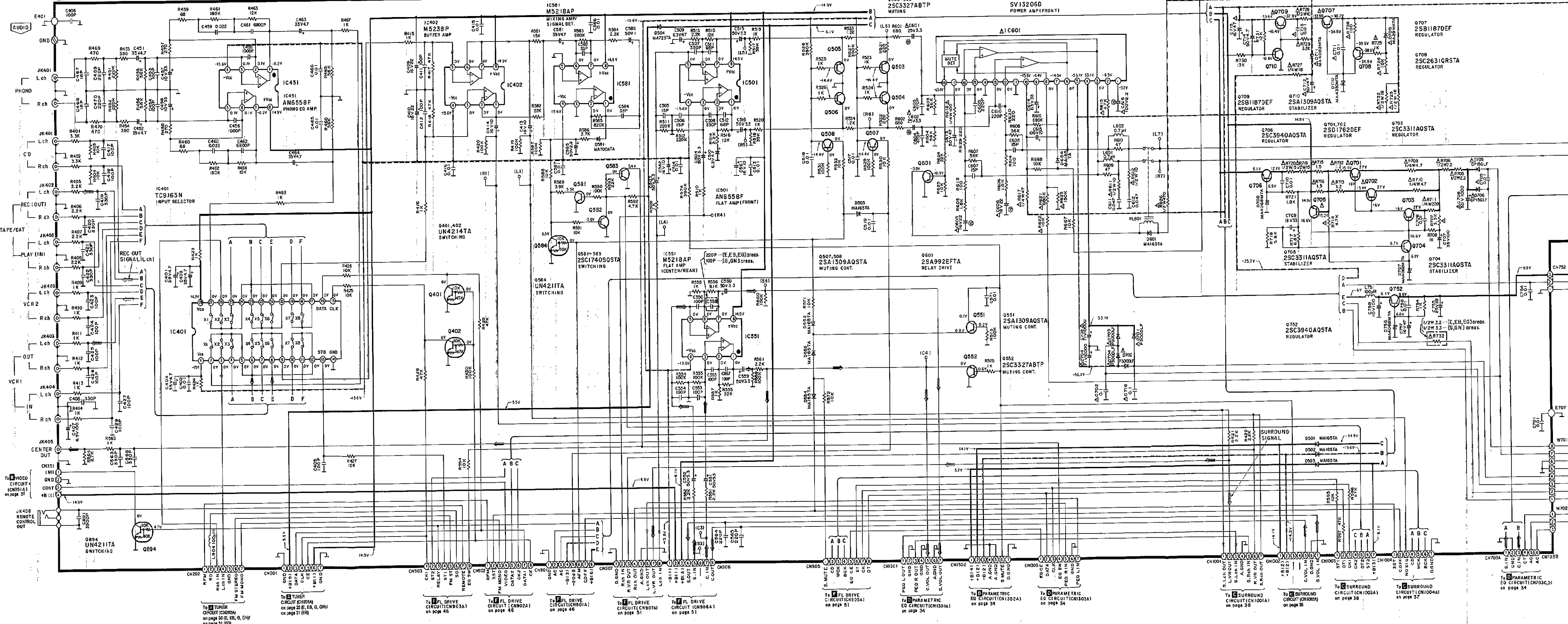

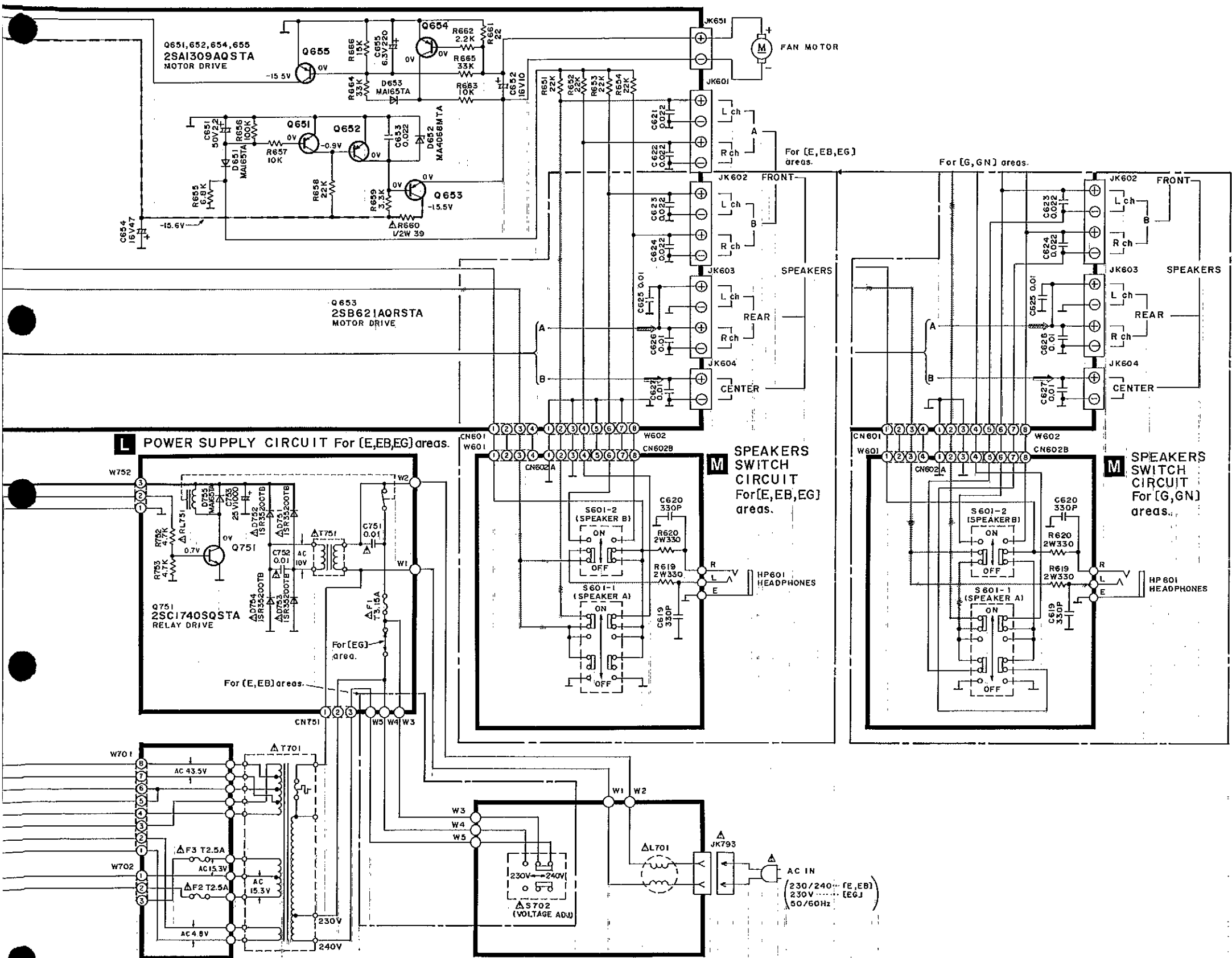

L POWER SUPPLY CIRCUIT For [E,EB,EG] areas.

M SPEAKERS SWITCH CIRCUIT For [E,EB,EG] areas.

N FUSE CIRCUIT For [E,EB,EG] areas.

O AC IN CIRCUIT For [E,EB,EG] areas.

Power Source Circuit For [G] area.

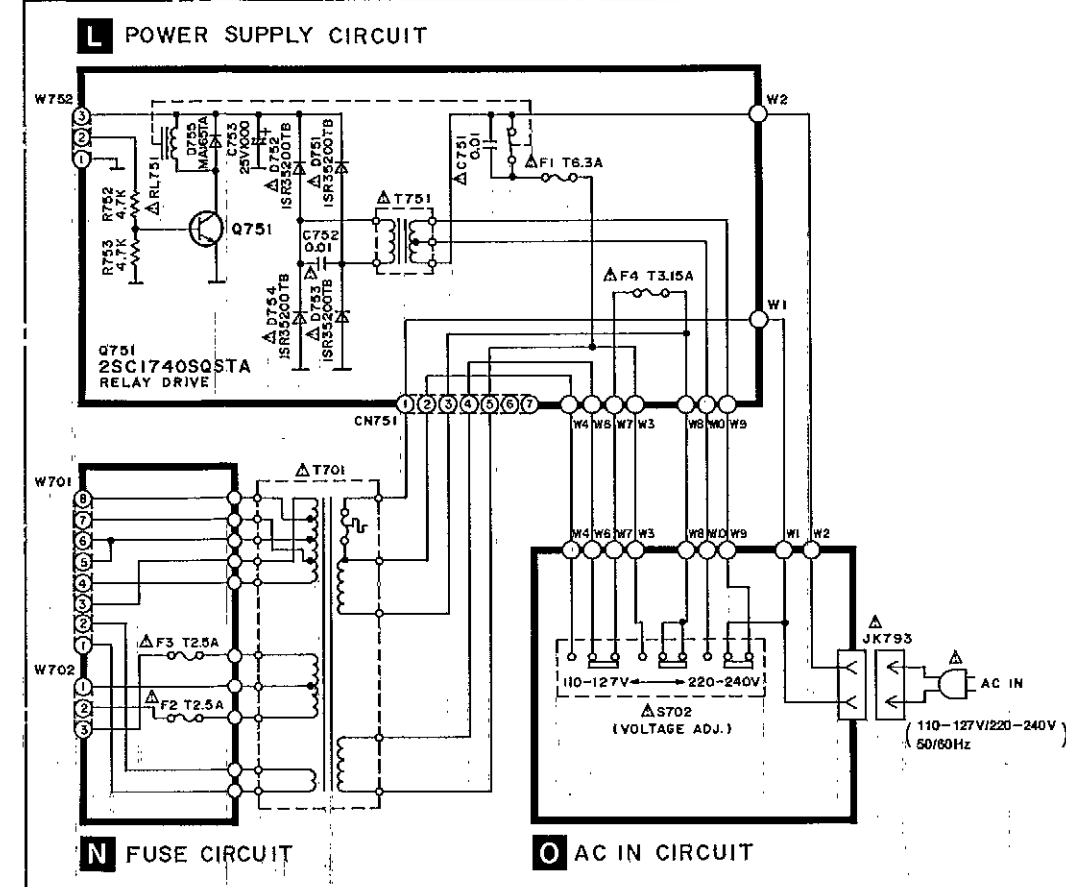

N FUSE CIRCUIT

O AC IN CIRCUIT

Power Source Circuit For [GN] area.

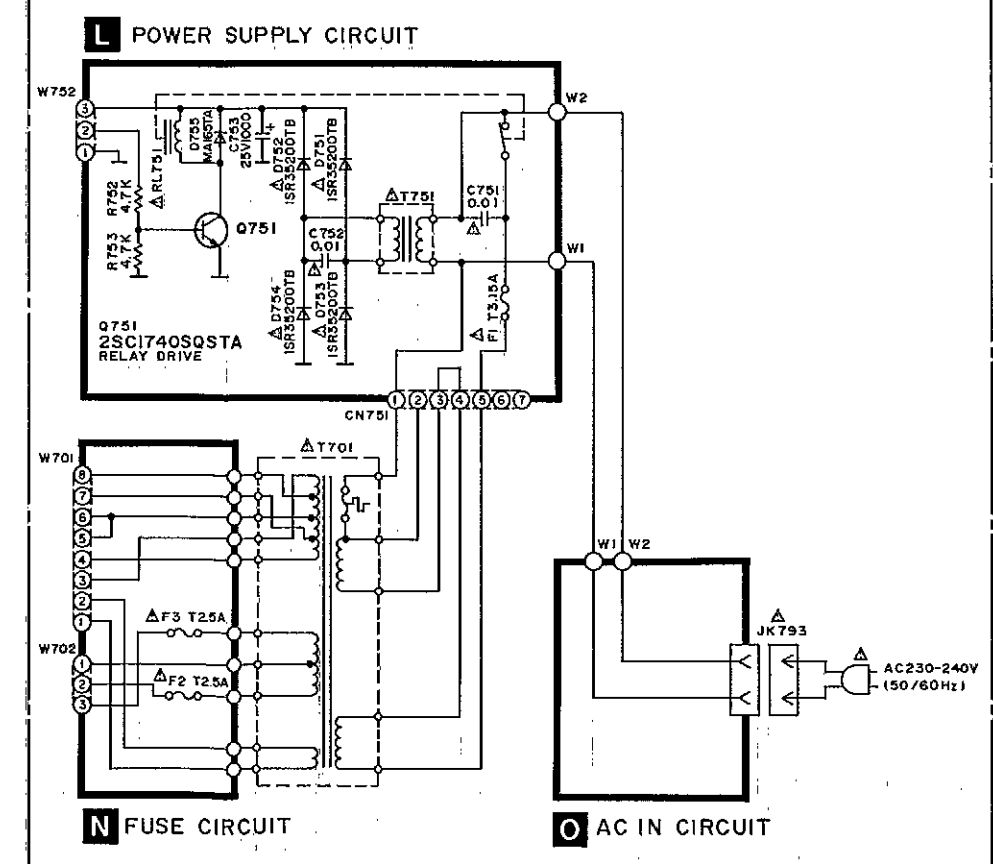

N FUSE CIRCUIT

O AC IN CIRCUIT

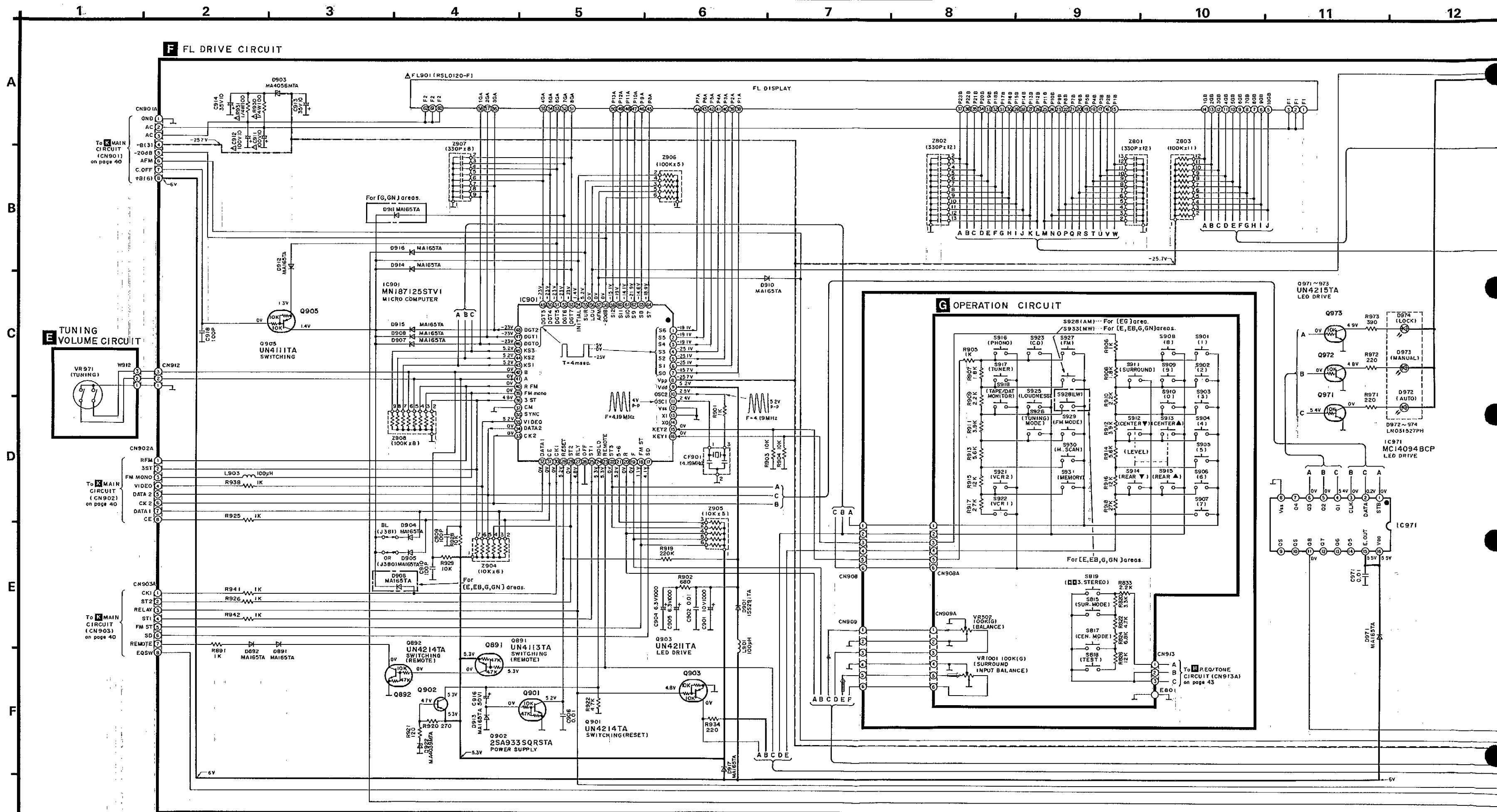

A
B
C
D
E
F
G

F FL DRIVE CIRCUIT

E TUNING VOLUME CIRCUIT

G OPERATION CIRCUIT

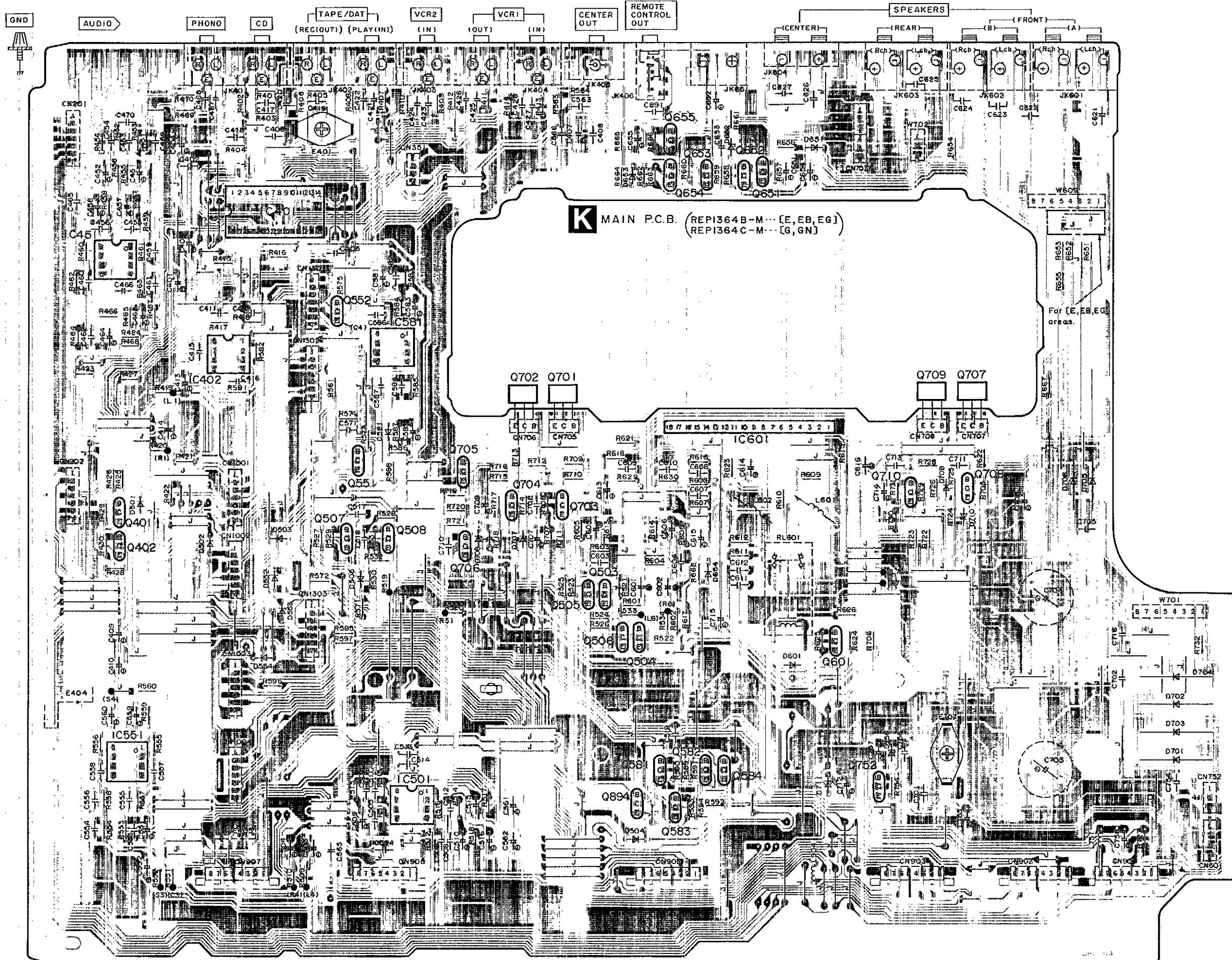

K MAIN P.C.B. (REPI364B-M... [E, EB, EG]
REPI364C-M... [G, GN])

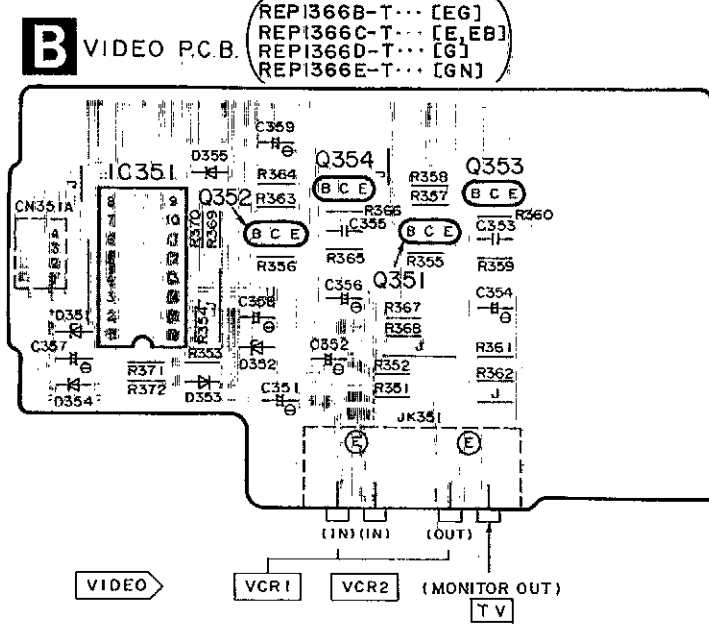

B VIDEO P.C.B. (REPI366B-T... [EG]
REPI366C-T... [E, EB]
REPI366D-T... [G]
REPI366E-T... [GN])

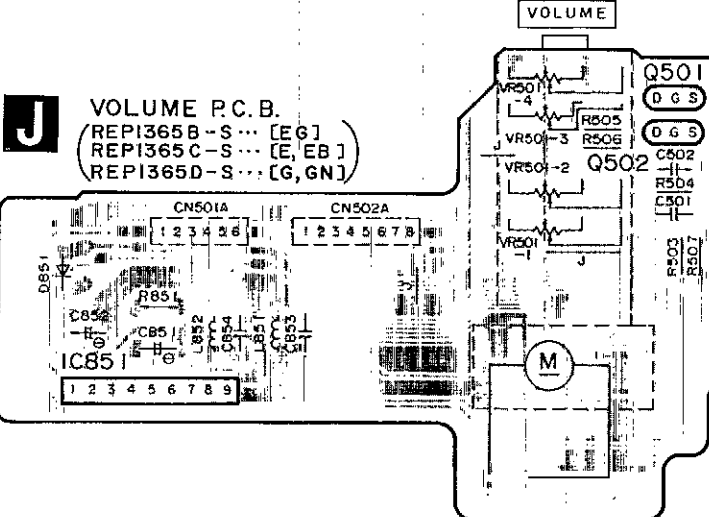

J VOLUME P.C.B. (REPI365B-S... [EG]
REPI365C-S... [E, EB]
REPI365D-S... [G, GN])

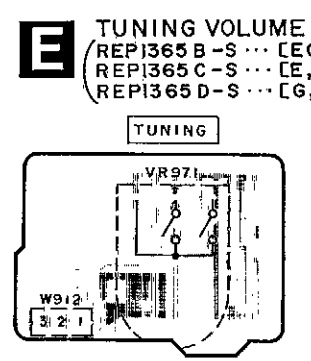

E TUNING VOLUME P.C.B. (REPI365B-S... [EG]
REPI365C-S... [E, EB]
REPI365D-S... [G, GN])

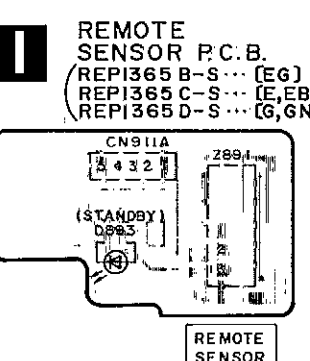

I REMOTE SENSOR P.C.B. (REPI365B-S... [EG]
REPI365C-S... [E, EB]
REPI365D-S... [G, GN])

1 2 3 4 5 6 7 8 9 10 11 12 13 14

A

B

C

D

E

F

G

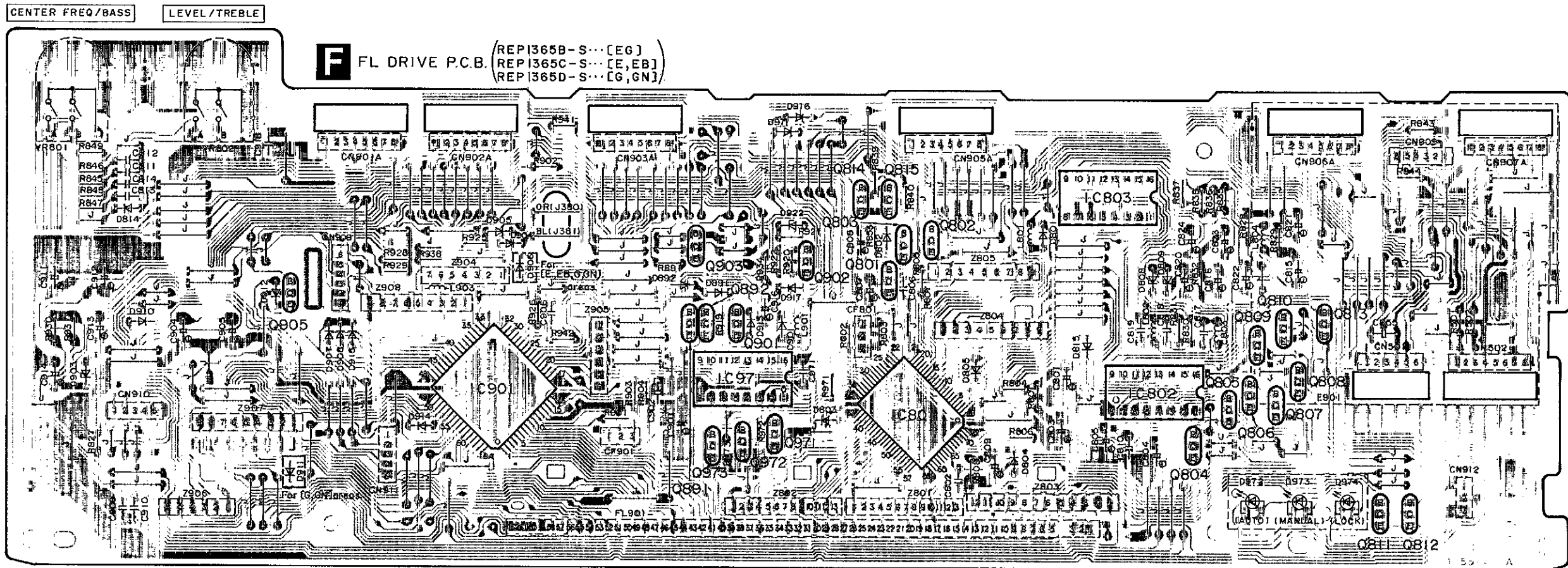

H P.EQ/TONE P.C.B. (REP1366B-T...[EG]
REP1366C-T...[E,EB]
REP1366D-T...[G]
REP1366E-T...[GN])

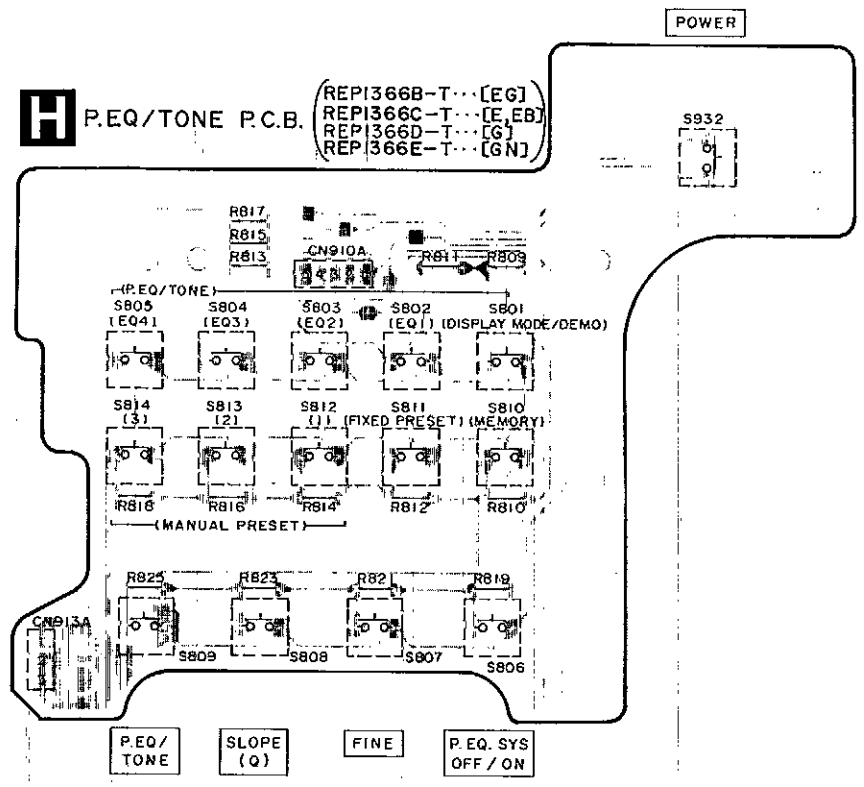

O AC IN P.C.B. For [E,EB,EG] areas. (REP1366B-T...[EG]
REP1366C-T...[E,EB])

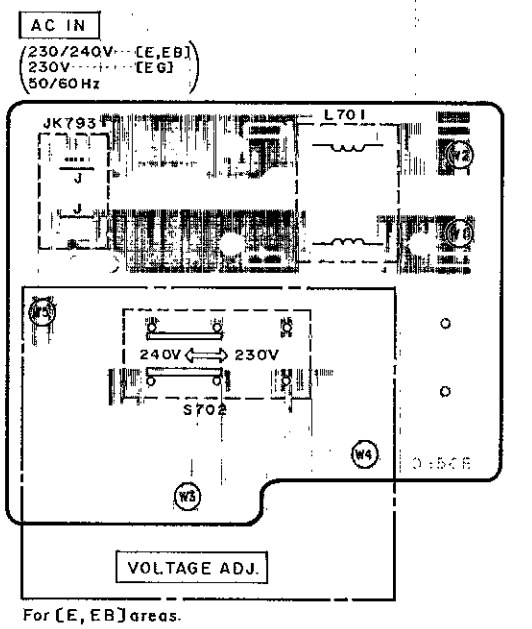

G OPERATION P.C.B. (REP1366B-T...[EG]
REP1366C-T...[E,EB]
REP1366D-T...[G]
REP1366E-T...[GN])

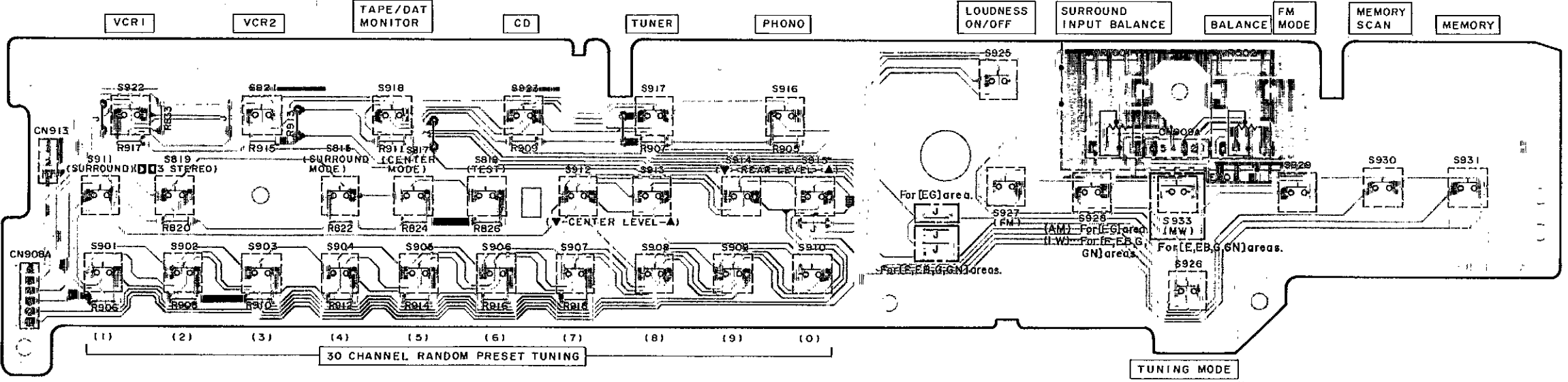

L POWER SUPPLY P.C.B. For [E,EB,EG] areas. (REP1366B-T...[EG]
REP1366C-T...[E,EB])

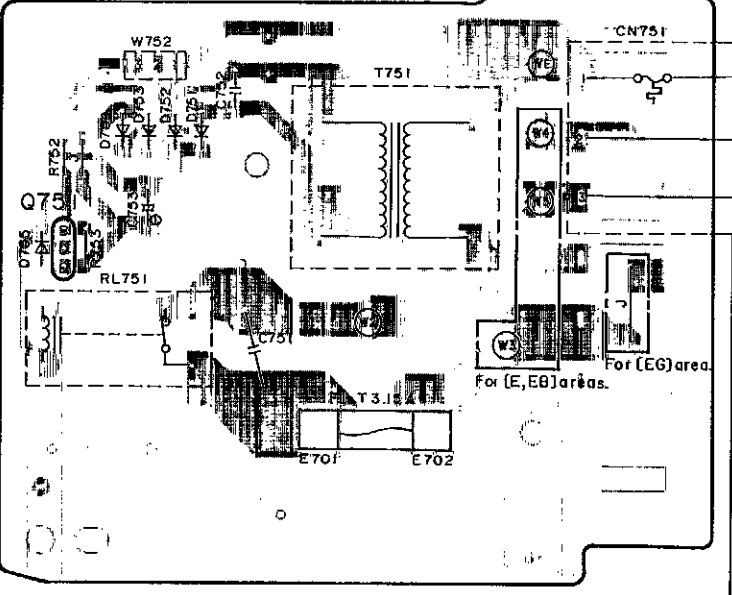

N FUSE P.C.B. For [E,EB,EG] areas. (REP1364B-M)

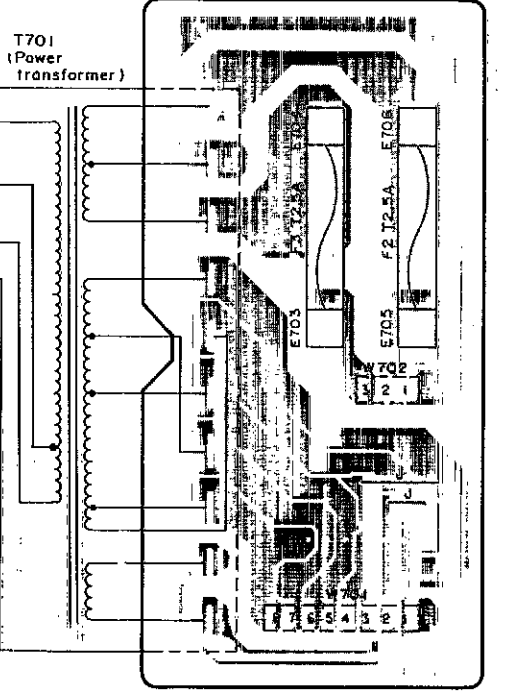

Power Source P.C.B. For [G] area.

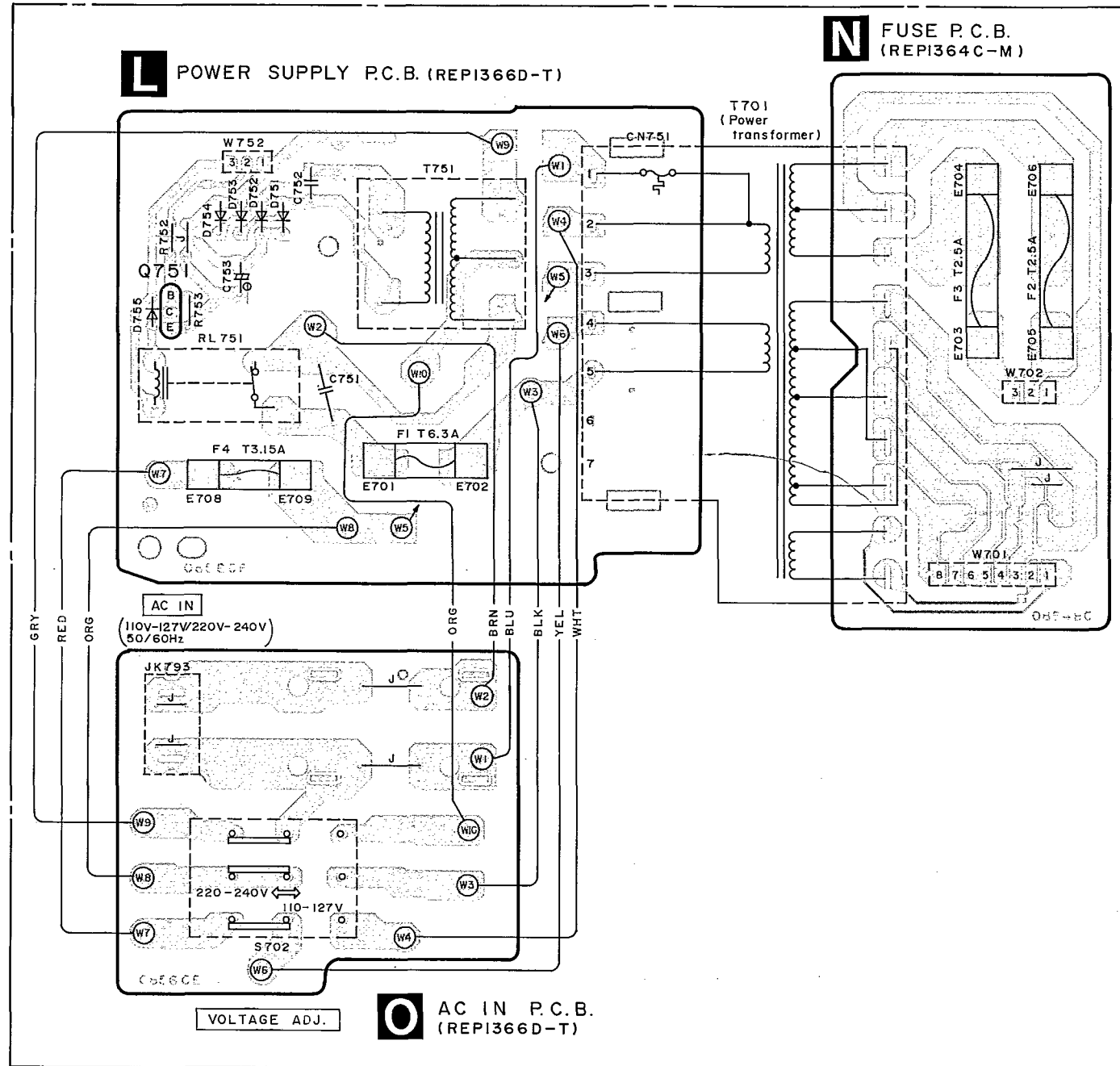

Power Source P.C.B. For [GN] area.

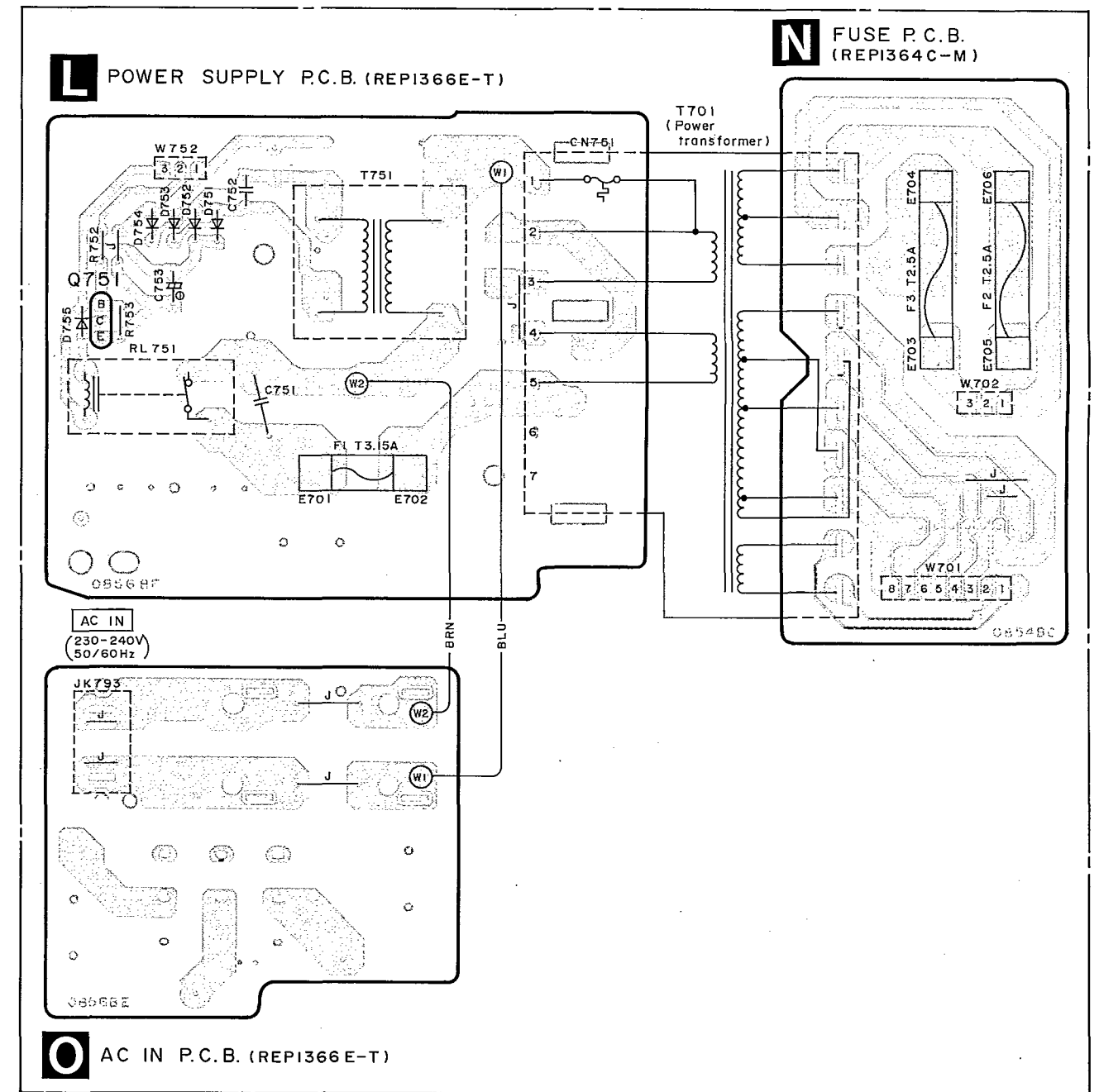

WIRING CONNECTION DIAGRAM

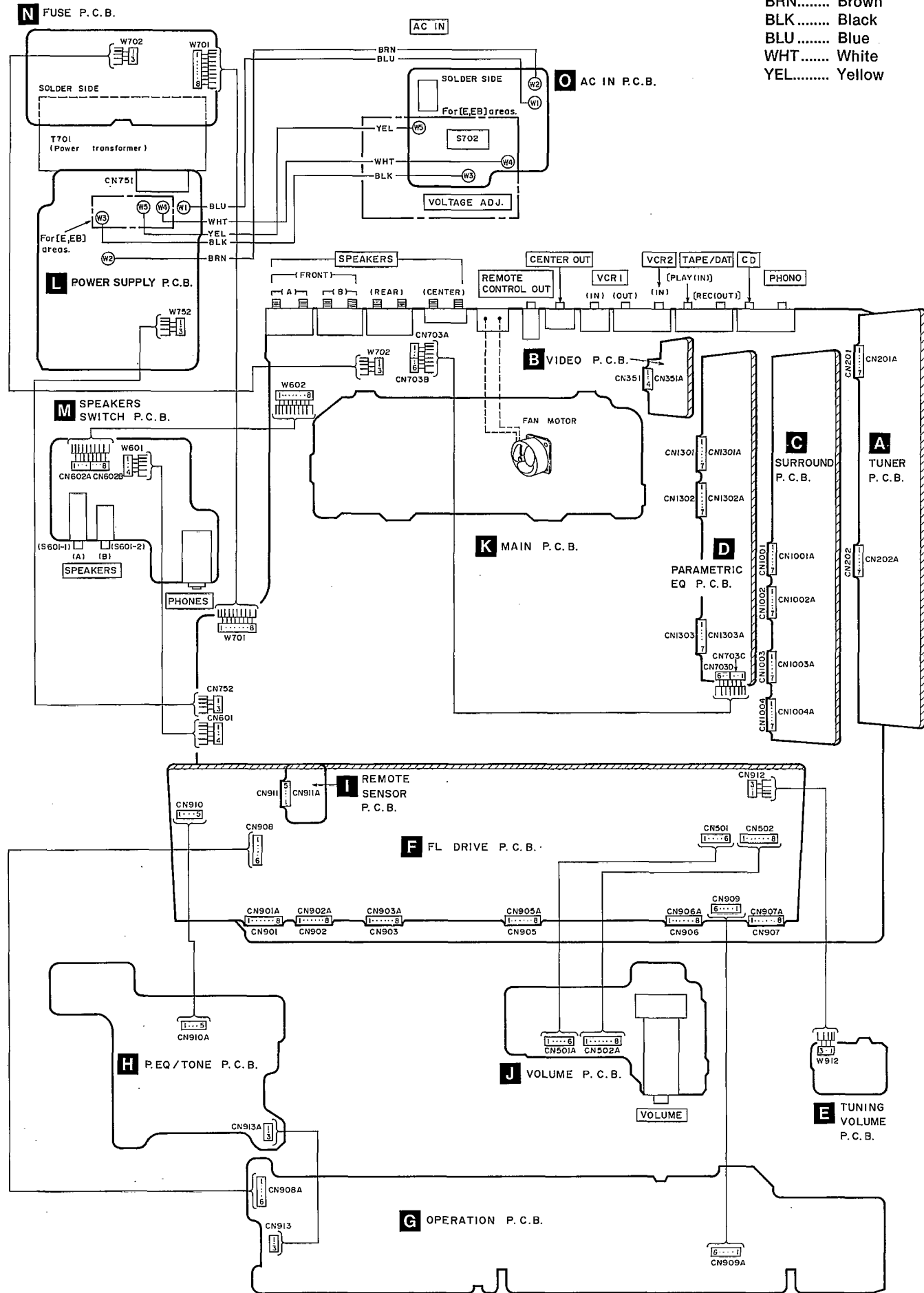

NOTES:

- BRN..... Brown
- BLK..... Black
- BLU..... Blue
- WHT..... White
- YEL..... Yellow

TERMINAL FUNCTION OF IC'S

• IC801 (M50946-150FP): Microcomputer

Pin No.	Mark	I/O Division	Function
1	f6	I	Spectrum analyzer signal
2	f7	I	
3	KIN	I	Key return signal
4	NC	—	Not connected
5	KS1/DIGA KS4/DIGD	O	Key scan signal and digit signal to FL display
8			
9	CURSW	—	Not used, connected to resistor
10	SEL MUTE	—	
11	EQSW	O	Equalizer selector control terminal
12	DT	O	Serial data signal
13	CK	O	Serial clock signal
14	ST	—	Not used, connected to resistor
15	CE	O	Chip enable terminal
16	BCK	—	Not used, connected to resistor
17	WCK	—	
18	CD	—	
19	NO SIGNAL	I	Mixing signal level detect terminal
20	HOLD	I	Power failure detect terminal
21	CNVss	—	GND terminal
22	RST	I	Reset detect terminal
23	NC	—	Not connected
24	NC	—	
25	Xin	I	Crystal oscillator terminal (6MHz)
26	Xout	O	

Pin No.	Mark	I/O Division	Function
27	Xcin	—	Not used, connected to GND
28	Xcout	—	Not used, open
29	Vss	—	GND terminal
30	NC	—	Not connected
31	LVL A	I	Frequency level or high-frequency sound detect terminal
32	LVL B		
33	FRQA	I	Center frequency or low-frequency sound detect terminal
34	FRQB		
35	NC	—	Not connected
36	Vp	I	Power supply terminal to FL display
37	MUTE	I	Muting detect terminal
38	S7 S23	O	Segment signal to FL display
54			
55	NC	—	Not connected
56	NC	—	
57	S1 S6	O	Segment signal to FL display
62			
63	AVcc	I	Power supply terminal
64	Vdd	—	GND terminal
65	Vss	—	
66	AVss	—	
67	Vref	I	Power supply terminal
68	f1 f5	I	Spectrum analyzer signal
72			

• IC901 (MN187125STV1): Microcomputer

Pin No.	Mark	I/O Division	Function
1 } 7	S0 } S6	O	Segment signal to FL display
8	Vpp	I	Power supply terminal to FL display
9	Vdd	I	Power supply terminal
10	OSC2	O	Crystal oscillator terminal (4.19MHz)
11	OSC1	I	
12	Vss	—	GND terminal
13	XI	—	Not used, connected to GND
14	XO	—	Not used, open
15	KEY2	I	Key return signal
16	KEY1		
17	SD	I	Received signal detect terminal
18	FM ST	I	Stereo signal detect terminal
19	F	O	Sense of rotation for volume motor control terminal
20	R		
21	5-6	—	Not used, connected to resistor
22	ST3	O	Level shift control terminal
23	REMOTE	I	Remote control terminal
24	HOLD	I	Service interruption detect terminal
25	ST1	O	Level shift control terminal
26	OFF	—	Not used, connected to GND
27	RLY	O	Relay control terminal
28	ST2	O	Level shift control terminal
29	RESET	I	Reset detect terminal
30	CK1	O	Serial clock signal

Pin No.	Mark	I/O Division	Function
31	CE	O	Chip enable terminal
32	DATA1	O	Serial data signal
33	CK2	O	Serial clock signal
34	DATA2	O	Serial data signal
35	VIDEO	O	Video selector control terminal
36	SYNC	—	Not used, open
37	CM	—	Not used, connected to GND
38	3ST	—	Not used, connected to resistor
39	FM mono	O	Forcible monaural signal
40	RFM	O	Muting control to tuner circuit
41	A	I	Rotary tuning control terminal
42	B		
43 } 45	KS1 } KS3	O	Key scan signal
46 } 53	DGT0 } DGT7	O	Digit signal to FL display
54	initial	I	Serial data detect terminal
55	DAC/sur	O	Muting control signal
56	lou	O	Loudness control signal
57	AFM	O	Muting control to amplifier circuit
58	-20dB	O	Muting control (-20dB) to amplifier circuit
59 } 64	S7 } S12	O	Segment signal to FL display

REPLACEMENT PARTS LIST

Notes: *Important safety notice:

 Components identified by Δ mark have special characteristics important for safety.

Furthermore, special parts which have purposes of fire-retardant (resistors), high-quality sound (capacitors), low-noise (resistors), etc. are used.

When replacing any of components, be sure to use only manufacturer's specified parts shown in the parts list.

*The parenthesized indications in the Remarks columns specify the areas. (Refer to the cover page for area.)

Parts without these indications can be used for all areas.

*Remote Control Ass'y:

Supply period for three years from termination of production.

Ref. No.	Part No.	Part Name & Description	Remarks	Ref. No.	Part No.	Part Name & Description	Remarks
		INTEGRATED CIRCUIT(S)		Q255, 256	2SC2785FE	TRANSISTOR	(E, EB, G, GN)
				Q301, 302	2SD1450QRSTA	TRANSISTOR	
				Q303	2SA933SQ	TRANSISTOR	
IC101	LM7001	IC, PLL FREQ. SYNTHESIZER		Q351, 352	2SC3311A-Q	TRANSISTOR	
IC201	AN7273A	IC, FM/AM IF AMP&MIXER		Q353, 354	2SA1015Y	TRANSISTOR	
IC301	SVIUPC1161C3	IC, FM MPX		Q401, 402	UN4214TA	TRANSISTOR	
IC351	TC4053BP	IC, VIDEO SELECTOR		Q501, 502	2SJ40CDTA	TRANSISTOR	
IC401	TC9163N	IC, INPUT SELECTOR		Q503-506	2SC3327-A	TRANSISTOR	
IC402	M5238P-1	IC, BUFFER AMP		Q507, 508	2SA1309A-R	TRANSISTOR	
IC451	AN6558F	IC, PHONO EQ AMP		Q551	2SA1309A-R	TRANSISTOR	
IC501	AN6558F	IC, FLAT AMP		Q552	2SC3327-A	TRANSISTOR	
IC551	M5218AP	IC, FLAT AMP		Q581-583	2SC1740SQ	TRANSISTOR	
IC581	M5218AP	IC, MIXING AMP		Q584	UN4211	TRANSISTOR	
IC601	SV13206D	IC, POWER AMP	Δ	Q601	2SA992EFTA	TRANSISTOR	
IC801	M50946-150FP	IC, MICROCOMPUTER		Q651, 652	2SA1309A-R	TRANSISTOR	
IC802	TC74HC42AP	IC, FL DRIVE		Q653	2SB621A-R	TRANSISTOR	
IC803	XR-1091ECP	IC, SPECTRUM ANALYZER		Q654, 655	2SA1309A-R	TRANSISTOR	
IC851	BA6218	IC, MOTOR DRIVE		Q701, 702	2SD1762DEF	TRANSISTOR	Δ
IC901	MN187125STV1	IC, MICROCOMPUTER		Q703, 704	2SC3311A-Q	TRANSISTOR	
IC971	MC14094BCP	IC, LED DRIVE		Q705	2SC3311A-Q	TRANSISTOR	Δ
IC1001	YM7306C	IC, DOLBY PRO-LOGIC DECODER		Q706	2SC3940AQSTA	TRANSISTOR	
IC1002	KM41C464P-10	IC, D. RAM		Q707	2SB1187DEF	TRANSISTOR	Δ
IC1003	MN1381STA	IC, RESET		Q708	2SC2631QRSTA	TRANSISTOR	
IC1004	AN6554F	IC, L. P. FILTER AMP		Q709	2SB1187DEF	TRANSISTOR	Δ
IC1005	AN6554F	IC, L. P. FILTER AMP		Q710	2SA1309A-R	TRANSISTOR	
IC1006	M5218AP	IC, BUFFER AMP		Q751	2SC1740SQ	TRANSISTOR	
IC1007	TC9162N	IC, MODE SELECTOR		Q752	2SC3940AQSTA	TRANSISTOR	
IC1008	AN6554F	IC, MIXING AMP		Q801	UN4214TA	TRANSISTOR	
IC1010	M5238P-1	IC, L. P. FILTER AMP		Q802	UN4211	TRANSISTOR	
IC1011	M5238P-1	IC, BUFFER AMP		Q803	UN4111	TRANSISTOR	
IC1012	M5218AP	IC, L. P. FILTER AMP		Q804-813	UN4115	TRANSISTOR	
IC1101	TC9212P	IC, ATTENUATOR		Q814, 815	UN4211	TRANSISTOR	
IC1102	M5218AP	IC, BUFFER AMP		Q891	UN4113TA	TRANSISTOR	
IC1301	SV13101D	IC, POWER AMP	Δ	Q892	UN4214TA	TRANSISTOR	
IC2001	LV3100M	IC, PARAMETRIC EQUALIZER		Q894	UN4211	TRANSISTOR	
IC2002	TC9214P	IC, ANALOG SWITCH		Q901	UN4214TA	TRANSISTOR	
IC2003	M5218AP	IC, BUFFER AMP		Q902	2SA933SQ	TRANSISTOR	
		TRANSISTOR(S)		Q903	UN4211	TRANSISTOR	
				Q905	UN4111	TRANSISTOR	
				Q971-973	UN4215	TRANSISTOR	
Q101, 102	2SC2785FE	TRANSISTOR		Q1001, 1002	2SC3327-A	TRANSISTOR	
Q201, 202	2SC2787L	TRANSISTOR		Q1003	2SA933SQ	TRANSISTOR	
Q204-207	2SC1740SQ	TRANSISTOR		Q1005	2SC3327-A	TRANSISTOR	
Q208, 209	2SA933SQ	TRANSISTOR		Q1006	DTC114ESTP	TRANSISTOR	
Q210	2SC1740SQ	TRANSISTOR		Q1301	2SC3327-A	TRANSISTOR	
Q251	2SA933SQ	TRANSISTOR	(E, EB, G, GN)				
Q252-254	2SC1740SQ	TRANSISTOR	(E, EB, G, GN)			DIODE(S)	

Ref. No.	Part No.	Part Name & Description	Remarks	Ref. No.	Part No.	Part Name & Description	Remarks
D101	MA165	DIODE		VR301	EVNDXAA00B53	V. R. FM MPX VCO ADJ.	
D204	MA165	DIODE		VR501	EUWMJTF25B15	V. R. MAIN VOLUME	
D206	MA165	DIODE		VR502	EVJ02SF01G15	V. R. BALANCE	
D301	MA165	DIODE		VR801, 802	EVQWQ202224B	V. R. FREQ/BASS. LEVEL/TREBLE	
D351	MA4036MTA	DIODE		VR971	EVQWPCF2024B	V. R. ROTARY TUNING	
D352	MA4056MTA	DIODE		VR1001	EVJ02SF01G15	V. R. SURROUND BALANCE	
D353-355	MA165	DIODE				COMPONENT COMBINATION (S)	
D501-503	MA165	DIODE		Z201	RLA6Z002-T	COIL	(E, EB, G, GN)
D504	MA723TA	DIODE		Z201	RLA2Z001-T	COIL	(EG)
D505	MA165	DIODE		Z202	SLI7Z101-T	COMPONENT COMBINATION	
D552-554	MA165	DIODE		Z321	SLA4Z13-Z	COMPONENT COMBINATION	
D581	MA700	DIODE		Z801, 802	EXFP12331MF	COMPONENT COMBINATION	
D601	MA165	DIODE		Z803	EXBF12E104J	COMPONENT COMBINATION	
D651	MA165	DIODE		Z804, 805	EXBF9E473J	COMPONENT COMBINATION	
D652	MA4068M	DIODE		Z891	RCDHC-677	REMOTE SENSOR	
D653, 654	MA165	DIODE		Z904	EXBF7E103J	COMPONENT COMBINATION	
D701-704	P300DLF	DIODE	△	Z905	EXBF6E103J	COMPONENT COMBINATION	
D705, 706	GP15GLF	DIODE	△	Z906	EXBF6E104J	COMPONENT COMBINATION	
D707	MA4062MTA	DIODE		Z907	EXFP8331MW	COMPONENT COMBINATION	
D708	MA4068M	DIODE		Z908	EXBF9E104J	COMPONENT COMBINATION	
D709	MA29WA	DIODE	△			COIL (S)	
D710	MA4330MTA	DIODE		L101	RLQZPR47KT-Y	COIL	
D711	MA4082MTA	DIODE	△	L203	ELEPKR22MA	COIL	(E, EB, G, GN)
D751-754	1SR35200TB	RECTIFIER	△	L203	ELEPK1ROMA	COIL	(EG)
D755	MA165	DIODE		L204	ELEPKR22MA	COIL	(E, EB, G, GN)
D756	MA4068M	DIODE		L204	ELEPK1ROMA	COIL	(EG)
D801	1SS291TA	DIODE		L321, 322	RLM2B003-K	COIL	
D802-805	MA165	DIODE		L323	SLM1B10M-1M	COIL	
D808, 809	MA4051MTA	DIODE		L325	RLQZP1R2KT-Y	COIL	
D814, 815	MA165	DIODE		L601, 602	SLQY07G-40	COIL	
D851	1SR35200TB	DIODE		L701	SLQZ650MH49	COIL	(E, EB, EG) △
D891, 892	MA165	DIODE		L751	ELEPK101KA	COIL	
D893	LN018304P	L. E. D.		L801	RLQZP101KT-Y	COIL	
D901	1SS291TA	DIODE		L802-804	RLQZP4R7KT-Y	COIL	
D903	MA4056MTA	DIODE		L851, 852	RLQZP1R0KT-Y	COIL	
D904, 905	MA165	DIODE		L901	ELEPK101KA	COIL	
D906	MA165	DIODE	(E, EB, G, GN)	L903, 904	RLQZP101KT-Y	COIL	
D907, 908	MA165	DIODE		L1002	RLQZP101KT-Y	COIL	
D910	MA165	DIODE		L1004, 1005	RLQZP101KT-Y	COIL	
D911	MA165	DIODE	(G, GN)	L1301, 1302	SLQY07G-40	COIL	
D912-917	MA165	DIODE				TRANSFORMER (S)	
D922	MA4039MTA	DIODE		T201	RLI4B012-Z	TRANSFORMER, FM-1F	
D971	MA165	DIODE		T202	RLI4B013-Z	TRANSFORMER, FM-1F	
D972-974	LN031527PH	L. E. D. BLOCK		T701	RTP1Q5E007-V	POWER TRANSFORMER (MAIN)	(E, EB, EG) △
D1003-1012	MA165	DIODE		T701	RTP1Q5E008-V	POWER TRANSFORMER (MAIN)	(G, GN) △
D1013	MA4051MTA	DIODE		T751	RTP1I5E003-V	POWER TRANSFORMER (SUB)	(E, EB, EG) △
D1301-1304	GP15GLF	DIODE	△				
D2002-2005	MA165	DIODE					
		VARIABLE RESISTOR (S)					

Ref. No.	Part No.	Part Name & Description	Remarks	Ref. No.	Part No.	Part Name & Description	Remarks
T751	RTP115E005-V	POWER TRANSFORMER(SUB)	(G, GN) △	S903	EVQ21405R	SW, PRESET TUNING 3	
				S904	EVQ21405R	SW, PRESET TUNING 4	
		FILTER(S) & OSCILLATOR(S)		S905	EVQ21405R	SW, PRESET TUNING 5	
				S906	EVQ21405R	SW, PRESET TUNING 6	
CF201, 202	RLFETNGM02LA	RED (10. 700MHz)		S907	EVQ21405R	SW, PRESET TUNING 7	
CF201, 202	RLFETNGM02LB	BLUE (10. 675MHz)		S908	EVQ21405R	SW, PRESET TUNING 8	
CF201, 202	RLFETNGM02LC	ORANGE (10. 725MHz)		S909	EVQ21405R	SW, PRESET TUNING 9	
CF801	EF0GC6004T4	OSCILLATOR (6MHz)		S910	EVQ21405R	SW, PRESET TUNING 0	
CF901	EF0GC4194T4	OSCILLATOR (4. 19MHz)		S911	EVQ21405R	SW, SURROUND	
CF1001	EF0GC8464T4	OSCILLATOR (8. 46MHz)		S912	EVQ21405R	SW, CENTER LEVEL (DOWN)	
X101	SVQ49U722-S	OSCILLATOR (7. 2MHz)		S913	EVQ21405R	SW, CENTER LEVEL (UP)	
				S914	EVQ21405R	SW, REAR LEVEL (DOWN)	
		FL DISPLAY(S)		S915	EVQ21405R	SW, REAR LEVEL (UP)	
				S916	EVQ21405R	SW, INPUT SELECTOR (PHONO)	
FL901	RSL0120-F	FL DISPLAY	△	S917	EVQ21405R	SW, INPUT SELECTOR (TUNER)	
				S918	EVQ21405R	SW, INPUT SELECTOR (MONITOR)	
		FRONT END PACK ASS'Y		S921	EVQ21405R	SW, INPUT SELECTOR (VCR2)	
				S922	EVQ21405R	SW, INPUT SELECTOR (VCR1)	
TN101	SNVFE337G01	FM FRONT END		S923	EVQ21405R	SW, INPUT SELECTOR (CD)	
				S925	EVQ21405R	SW, LOUDNESS	
		FUSE (S)		S926	EVQ21405R	SW, TUNING MODE	
				S927	EVQ21405R	SW, BAND SELECTOR (FM)	
F1	XBA2C31TB0	FUSE, 250V 3. 15A	(E, EB, EG, GN) △	S928	EVQ21405R	SW, BAND SELECTOR (AM)	
F1	XBA2C63TB0	FUSE, 250V 6. 3A	(G) △	S929	EVQ21405R	SW, FM MODE	
F2, 3	XBA2C25TB0	FUSE, 250V 2. 5A	△	S930	EVQ21405R	SW, MEMORY SCAN	
F4	XBA2C31TB0	FUSE, 25V 3. 15A	(G) △	S931	EVQ21405R	SW, MEMORY	
				S932	EVQ21405R	SW, POWER	
		SWITCH(ES)		S933	EVQ21405R	SW, LW	(E, EB, G, GN)
S601	RSP2008-J	SW, SPEAKERS				RELAY (S)	
S702	ESD26200A	SW, VOLTAGE ADJUSTMENT	(E, EB, EG) △				
S702	ESD26840A	SW, VOLTAGE ADJUSTMENT	(G) △	RL601	RSY0013-0	RELAY	
S801	EVQ21405R	SW, DISPLAY MODE		RL751	RSY0012-0	RELAY	△
S802	EVQ21405R	SW, EQ1					
S803	EVQ21405R	SW, EQ2				JACK(S)	
S804	EVQ21405R	SW, EQ3					
S805	EVQ21405R	SW, EQ4		JK101	RJH4202	ANTENNA CONNECTION TERMINAL	(E, EB, EG)
S806	EVQ21405R	SW, P. EQ. SYS ON/OFF		JK101	RJH4405-1	ANTENNA CONNECTION TERMINAL	(G, GN)
S807	EVQ21405R	SW, FINE		JK351	SJF3069-3N	TERMINAL, MONITOR/VIDEO	
S808	EVQ21405R	SW, SLOPE (Q)		JK401	SJF3069N	TERMINAL, PHONO/CD	
S809	EVQ21405R	SW, P. EQ. /TONE		JK402	SJF3069N	TERMINAL, TAPE/DAT	
S810	EVQ21405R	SW, MEMORY		JK403	SJF3069N	TERMINAL, VCR2/VCR1	
S811	EVQ21405R	SW, FIXED PRESET		JK404	SJF3068N	TERMINAL, VCR1	
S812	EVQ21405R	SW, MANUAL PRESET 1		JK405	SJFD7	CENTER OUT	
S813	EVQ21405R	SW, MANUAL PRESET 2		JK406	RJJ33TR01	REMOTE CONTROL OUT	
S814	EVQ21405R	SW, MANUAL PRESET 3		JK601	RJR0054	FRONT SPEAKERS A	
S815	EVQ21405R	SW, SURROUND MODE		JK602	RJR0054	FRONT SPEAKERS B	
S817	EVQ21405R	SW, CENTER MODE		JK603	RJR0054	REAR SPEAKERS	
S818	EVQ21405R	SW, TEST		JK604	SJF5201-1	CENTER SPEAKERS	
S819	EVQ21405R	SW, 3 STEREO		JK651	RJS1A7402-1	FAN MOTOR JACK	
S901	EVQ21405R	SW, PRESET TUNING 1		JK793	SJS9231-1B	AC INLET	(E, EB, EG, G) △
S902	EVQ21405R	SW, PRESET TUNING 2		JK793	SJS9234B	AC INLET	(GN) △

Ref. No.	Part No.	Part Name & Description	Remarks	Ref. No.	Part No.	Part Name & Description	Remarks
HP601	RJJ63TS01	HEADPHONES		CN909A	SJS50681BB	SOCKET (6P)	
				CN910A	SJS50581BB	SOCKET (5P)	
		CONNECTOR (S) & SOCKET (S)		CN911A	SJS50581BB	SOCKET (5P)	
				CN913A	SJS50382JQH	SOCKET (3P)	
CN201, 202	RJT057W007-1	CONNECTOR (7P)		CN602B	RJS1A1704	SOCKET (4P)	
CN351	RJT057W004-1	CONNECTOR (4P)		CN703B	RJS1A1703	CONNECTOR (3P)	
CN351A	RJU057W004	SOCKET (4P)		CN703C	RJS1A1703	CONNECTOR (3P)	
CN501	RJT003K006-1	CONNECTOR (6P)		CN703D	RJS1A1703	CONNECTOR (3P)	
CN502	RJT003K008-1	CONNECTOR (8P)				SHIELD PART (S)	
CN601	RJS1A1704	SOCKET (4P)					
CN705-708	RJS1A1703	CONNECTOR (3P)		E101	RSC0283	SHIELD COVER	
CN751	SJS305-1	SOCKET (3P)	(E, EB, EG)	E401	SNE1004-1	GND PLATE	
CN751	SJS5711-1	SOCKET (5P)	(G, GN)	E404, 405	SME103-6	P. C. B. HOLDER	
CN752	RJS1A1703	CONNECTOR (3P)		E701-706	EYF52BC	FUSE HOLDER	
CN901A	RJT003K008-1	CONNECTOR (8P)		E707	SNE1004-1	GND PLATE	
CN901	RJU003K008M1	SOCKET (8P)		E708	EYF52BC	FUSE HOLDER	(G)
CN902A	RJT003K008-1	CONNECTOR (8P)		E709	EYF52BC	FUSE HOLDER	(G)
CN902	RJU003K008M1	SOCKET (8P)		E801	RSC0218	SHIELD PLATE	
CN903A	RJT003K008-1	CONNECTOR (8P)		E901	RSC0219-1	SHIELD PLATE	
CN903	RJU003K008M1	SOCKET (8P)		E1001	RSC0219-1	SHIELD PLATE	
CN905A	RJT003K008-1	CONNECTOR (8P)				PACKING MATERIAL	
CN905	RJU003K008M1	SOCKET (8P)					
CN906A	RJT003K008-1	CONNECTOR (8P)		P1	RPG1188	PACKING CASE	(E, EB, G, GN)
CN906	RJU003K008M1	SOCKET (8P)		P1	RPG1189	PACKING CASE	(EG)
CN907A	RJT003K008-1	CONNECTOR (8P)		P2	RPN0324-2	PAD	
CN907	RJU003K008M1	SOCKET (8P)		P3	XZB60X65A01Z	PROTECTION BAG (UNIT)	
CN908, 909	SJT30648BB1	CONNECTOR (6P)		P4	RPQ0164	PAD	
CN910	SJT30548BB1	CONNECTOR (5P)		P5	XZB24X34C04	PROTECTION BAG (ACCESSORIES)	
CN911	SJT30549BB1	CONNECTOR (5P)				ACCESSORIES	
CN912	RJS1A1703	CONNECTOR (3P)					
CN913	SJT30345JQ	CONNECTOR (3P)		A1	RFKSAGX530EK	INST. MANUAL ASS'Y	(E)
CN1001	RJT057W007-1	CONNECTOR (7P)		A1	RQT1603-B	INSTRUCTION MANUAL	(EB)
CN1001A	RJU057W007	SOCKET (7P)		A1	RQT1600-D	INSTRUCTION MANUAL	(EG)
CN1002	RJT057W007-1	CONNECTOR (7P)		A1	RQT1643-G	INSTRUCTION MANUAL	(G, GN)
CN1002A	RJU057W007	SOCKET (7P)		A2	RQA0013	WARRANTY CARD	(E, EB, EG)
CN1003	RJT057W007-1	CONNECTOR (7P)		A2	RQX7433ZA	WARRANTY CARD	(GN)
CN1003A	RJU057W007	SOCKET (7P)		A3	RQC80169	SERVICENTER LIST	
CN1004	RJT057W007-1	CONNECTOR (7P)		A4	RAK-SA503E	REMOTE CONTROL TRANSMITTER	
CN1004A	RJU057W007	SOCKET (7P)		A4-1	RKK0020-K	BATTERY COVER	FOR R/C TRANSMITTER
CN1301	RJT057W007-1	CONNECTOR (7P)		A5	RJA0019-1K	AC POWER SUPPLY CORD	(E, EG) △
CN1301A	RJU057W007	SOCKET (7P)		A5	SJA193	AC POWER SUPPLY CORD	(EB) △
CN1302	RJT057W007-1	CONNECTOR (7P)		A5	RJA0004	AC POWER SUPPLY CORD	(G) △
CN1302A	RJU057W007	SOCKET (7P)		A5	SJA173	AC POWER SUPPLY CORD	(GN) △
CN1303	RJT057W007-1	CONNECTOR (7P)		A6	SPB1163T	AM LOOP ANTENNA	
CN1303A	RJU057W007	SOCKET (7P)		A6-1	SMA233-1M	AM ANTENNA HOLDER	
CN201A	RJU057W007	SOCKET (7P)		A6-2	XTN3+10AFZ	SCREW	
CN202A	RJU057W007	SOCKET (7P)		A7	RSA0007	FM INDOOR ANTENNA	(E, EB, EG)
CN501A	RJU003K006M1	SOCKET (6P)		A7	RSA0006	FM INDOOR ANTENNA	(G, GN)
CN502A	RJU003K008M1	SOCKET (8P)		A8	RQLA0134	VOLTAGE CAUTION LABEL	(E, EB, G)
CN602A	RJS1A1704	SOCKET (4P)		A9	SJP9009	ATTACHMENT PLUG	(EB) △
CN703A	RJS1A1703	CONNECTOR (3P)		A10	SJP9215	AC PLUG ADAPTOR	(G) △
CN908A	SJS50681BB	SOCKET (6P)					

RESISTORS AND CAPACITORS

Notes : * Capacity values are in microfarads (uF) unless specified otherwise, P-Pico-farads (pF) F-Farads (F)
 * Resistance values are in ohms, unless specified otherwise, 1K=1,000(OHM) , 1M=1,000k(OHM)

Ref. No.	Part No.	Values & Remarks	Ref. No.	Part No.	Values & Remarks	Ref. No.	Part No.	Values & Remarks
RESISTORS								
R101, 102	ERDS2TJ103	1/4W 10K	R253	ERDS2TJ182	1/4W 1.8K E, EB, G, GN	R409-416	ERDS2TJ102	1/4W 1K
R104	ERDS2TJ102	1/4W 1K	R254	ERDS2TJ223	1/4W 22K E, EB, G, GN	R417, 418	ERDS2TJ473	1/4W 47K
R105	ERDS2TJ561	1/4W 560	R256	ERDS2TJ102	1/4W 1K E, EB, G, GN	R419, 420	ERDS2TJ104	1/4W 100K
R106	ERDS2TJ562	1/4W 5.6K	R258	ERDS2TJ122	1/4W 1.2K E, EB, G, GN	R421, 422	ERDS2TJ222	1/4W 2.2K
R107	ERDS2TJ103	1/4W 10K	R259	ERDS2TJ223	1/4W 22K E, EB, G, GN	R423, 424	ERDS2TJ102	1/4W 1K
R108	ERDS2TJ151	1/4W 150	R261	ERDS2TJ102	1/4W 1K E, EB, G, GN	R425-427	ERDS2TJ103	1/4W 10K
R201	ERDS2TJ103	1/4W 10K	R262	ERDS2TJ332	1/4W 3.3K E, EB, G, GN	R428, 429	ERDS2TJ473	1/4W 47K
R202	ERDS2TJ824	1/4W 820K	R263	ERDS2TJ153	1/4W 15K E, EB, G, GN	R430	ERDS2TJ104	1/4W 100K
R203	ERDS2TJ331	1/4W 330	R264	ERDS2TJ102	1/4W 1K E, EB, G, GN	R451, 452	ERDS2TJ224T	1/4W 220K
R204	ERDS2TJ824	1/4W 820K	R301	ERDS2TJ393	1/4W 39K E, EB, G, GN	R453, 454	ERDS2TJ391	1/4W 390
R205	ERDS2TJ391	1/4W 390	R301	ERDS2TJ333	1/4W 33K EG	R455, 456	ERDS2TJ563	1/4W 56K
R206	ERDS2TJ561	1/4W 560	R302	ERDS2TJ151	1/4W 150	R457, 458	ERDS2TJ271	1/4W 270
R207	ERDS2TJ822	1/4W 8.2K	R303, 304	ERDS2TJ223	1/4W 22K	R459, 460	ERDS2TJ680T	1/4W 68
R208	ERDS2TJ102	1/4W 1K	R305, 306	ERDS2TJ272T	1/4W 2.7K	R461, 462	ERDS2TJ184T	1/4W 180K
R209	ERDS2TJ471	1/4W 470	R307, 308	ERDS2TJ562	1/4W 5.6K	R463, 464	ERDS2TJ123	1/4W 12K
R210	ERDS2TJ332	1/4W 3.3K	R309	ERDS2TJ154	1/4W 150K E, EB, G, GN	R465, 466	ERDS2TJ563	1/4W 56K
R211	ERDS2TJ222	1/4W 2.2K	R309	ERDS2TJ124	1/4W 120K EG	R467, 468	ERDS2TJ102	1/4W 1K
R212	ERDS2TJ153	1/4W 15K	R311	ERDS2TJ102	1/4W 1K	R469, 470	ERDS2TJ471	1/4W 470
R213	ERDS2TJ104	1/4W 100K	R312	ERDS2TJ153	1/4W 15K	R501, 502	ERDS2TJ222	1/4W 2.2K
R214	ERDS2TJ824	1/4W 820K	R313, 314	ERDS2TJ473	1/4W 47K	R503-506	ERDS2TJ103	1/4W 10K
R215	ERDS2TJ153	1/4W 15K	R315	ERDS2TJ103	1/4W 10K	R507	ERDS2TJ153	1/4W 15K
R216	ERDS2TJ563	1/4W 56K	R316	ERDS2TJ222	1/4W 2.2K	R509, 510	ERDS2TJ102	1/4W 1K
R217	ERDS2TJ223	1/4W 22K	R317	ERDS2TJ473	1/4W 47K	R511, 512	ERDS2TJ224T	1/4W 220K
R218	ERDS2TJ563	1/4W 56K	R321	ERDS2TJ333	1/4W 33K E, EB, G, GN	R513, 514	ERDS2TJ222	1/4W 2.2K
R219	ERDS2TJ223	1/4W 22K	R321	ERDS2TJ153	1/4W 15K EG	R515, 516	ERDS2TJ123	1/4W 12K
R220	ERDS2TJ103	1/4W 10K	R322	ERDS2TJ333	1/4W 33K E, EB, G, GN	R517, 518	ERDS2TJ393	1/4W 39K
R221	ERDS2TJ104	1/4W 100K	R322	ERDS2TJ153	1/4W 15K EG	R519, 520	ERDS2TJ102	1/4W 1K
R222	ERDS2TJ473	1/4W 47K	R325, 326	ERDS2TJ102	1/4W 1K	R521, 522	ERDS2TJ221	1/4W 220
R223	ERDS2TJ154	1/4W 150K	R351, 352	ERDS2TJ820	1/4W 82	R523-526	ERDS2TJ102	1/4W 1K
R224	ERDS2TJ223	1/4W 22K	R353, 354	ERDS2TJ104	1/4W 100K	R527, 528	ERDS2TJ394	1/4W 390K
R226	ERDS2TJ103	1/4W 10K	R355, 356	ERDS2TJ472	1/4W 4.7K	R529	ERDS2TJ104	1/4W 100K
R228	ERDS2TJ123	1/4W 12K	R357	ERDS2TJ101	1/4W 100	R530	ERDS2TJ103	1/4W 10K
R229	ERDS2TJ102	1/4W 1K EG	R358	ERDS2TJ470	1/4W 47	R531	ERDS2TJ104	1/4W 100K
R230	ERDS2TJ104	1/4W 100K	R359	ERDS2EJ121	1/4W 120	R532	ERDS2TJ103	1/4W 10K
R231	ERDS2TJ102	1/4W 1K E, EB, G, GN	R360	ERDS2TJ101	1/4W 100	R533, 534	ERDS2TJ122	1/4W 1.2K
R231	ERDS2TJ471	1/4W 470 EG	R361	ERDS2TJ680T	1/4W 68	R551, 552	ERDS2TJ222	1/4W 2.2K
R232	ERDS2TJ122	1/4W 1.2K	R362	ERDS2TJ103	1/4W 10K	R553, 554	ERDS2TJ104	1/4W 100K
R233	ERDS2TJ684	1/4W 680K	R363	ERDS2TJ101	1/4W 100	R555	ERDS2TJ223	1/4W 22K
R234	ERDS2TJ103	1/4W 10K	R364	ERDS2TJ470	1/4W 47	R556	ERDS2TJ912T	1/4W 9.1K
R235	ERDS2TJ471	1/4W 470	R365	ERDS2EJ121	1/4W 120	R557, 558	ERDS2TJ102	1/4W 1K
R236	ERDS2TJ183T	1/4W 18K	R366	ERDS2TJ101	1/4W 100	R559, 560	ERDS2TJ104	1/4W 100K
R238	ERDS2TJ271	1/4W 270	R367	ERDS2TJ680T	1/4W 68	R561	ERDS2TJ222	1/4W 2.2K
R240	ERDS2TJ152	1/4W 1.5K	R368	ERDS2TJ103	1/4W 10K	R563	ERDS2TJ102	1/4W 1K
R247	ERDS2TJ103	1/4W 10K	R369, 370	ERDS2TJ473	1/4W 47K	R564	ERDS2TJ272T	1/4W 2.7K
R251	ERDS2TJ103	1/4W 10K E, EB, G, GN	R371	ERDS2TJ222	1/4W 2.2K	R571, 572	ERDS2TJ103	1/4W 10K
R252	ERDS2TJ822	1/4W 8.2K E, EB, G, GN	R372	ERDS2TJ472	1/4W 4.7K	R573	ERDS2TJ104	1/4W 100K
			R401, 402	ERDS2TJ332	1/4W 3.3K	R574	ERDS2TJ394	1/4W 390K
			R403, 404	ERDS2TJ103	1/4W 10K	R575	ERDS2TJ102	1/4W 1K
			R405-408	ERDS2TJ222	1/4W 2.2K	R581	ERDS2TJ153	1/4W 15K

Ref. No.	Part No.	Values & Remarks	Ref. No.	Part No.	Values & Remarks	Ref. No.	Part No.	Values & Remarks
R582	ERDS2TJ223	1/4W 22K	R714	ERDS2TJ472	1/4W 4.7K Δ	R903, 904	ERDS2TJ103	1/4W 10K
R583	ERDS2TJ684	1/4W 680K	R715, 716	ERDS2TJ185T	1/4W 1.5 Δ	R905, 906	ERDS2TJ102	1/4W 1K
R584	ERDS2TJ222	1/4W 2.2K	R717	ERDS2TJ682T	1/4W 6.8K	R907, 908	ERDS2TJ182	1/4W 1.8K
R585	ERDS2TJ824	1/4W 820K	R718	ERDS2TJ562	1/4W 5.6K	R909, 910	ERDS2TJ222	1/4W 2.2K
R586	ERDS2TJ272T	1/4W 2.7K	R719, 720	ERDS1FVJ150T	1/2W 15 Δ	R911, 912	ERDS2TJ392T	1/4W 3.9K
R587	ERDS2TJ104	1/4W 100K	R721	ERDS2TJ182	1/4W 1.8K	R913, 914	ERDS2TJ562	1/4W 5.6K
R588	ERDS2TJ103	1/4W 10K	R722, 723	ERDS1FVJ180T	1/2W 18 Δ	R915, 916	ERDS2TJ123	1/4W 12K
R589	ERDS2TJ392T	1/4W 3.9K	R724	ERDS2TJ183T	1/4W 18K Δ	R917, 918	ERDS2TJ273	1/4W 27K
R590	ERDS2TJ104	1/4W 100K	R725	ERDS2TJ102	1/4W 1K Δ	R919	ERDS2TJ224T	1/4W 220K
R591	ERDS2TJ103	1/4W 10K	R726	ERDS2TJ101	1/4W 100 Δ	R920	ERDS2TJ271	1/4W 270
R592	ERDS2TJ472	1/4W 4.7K	R727	ERD25FVJ180T	1/4W 18 Δ	R921	ERDS2EJ121	1/4W 120
R593	ERDS2TJ223	1/4W 22K	R728	ERDS1FVJ100T	1/2W 10 Δ	R922	ERDS2TJ472	1/4W 4.7K
R594, 595	ERDS2TJ103	1/4W 10K	R729	ERDS2TJ332	1/4W 3.3K Δ	R925, 926	ERDS2TJ102	1/4W 1K
R596, 597	ERDS2TJ473	1/4W 47K	R730	ERDS2TJ133T	1/4W 13K	R928, 929	ERDS2TJ103	1/4W 10K
R601, 602	ERDS2TJ681	1/4W 680	R731	ERDS2TJ123	1/4W 12K	R930, 931	ERD25FJ101	1/4W 100 Δ
R603, 604	ERDS2TJ563	1/4W 56K	R732	ERDS1FVJ2R2T	1/2W 2.2 E, EB, EG Δ	R934	ERDS2TJ221	1/4W 220
R605, 606	ERDS2TJ182	1/4W 1.8K	R732	ERDS1FVJ3R3T	1/2W 3.3 G, GN Δ	R938	ERDS2TJ102	1/4W 1K
R607, 608	ERDS2TJ563	1/4W 56K	R752, 753	ERDS2TJ472	1/4W 4.7K	R941, 942	ERDS2TJ102	1/4W 1K
R609, 610	ERDS2TJ470	1/4W 47	R754	ERDS2TJ102	1/4W 1K	R971, 972	ERDS2TJ221	1/4W 220
R611, 612	ERDS1FVJ100T	1/2W 10 Δ	R801	ERDS2TJ681	1/4W 680	R973	ERDS2TJ391	1/4W 390
R613, 614	ERDS2TJ101	1/4W 100	R802	ERDS2TJ102	1/4W 1K	R1002, 1003	ERDS2TJ105T	1/4W 1M
R615	ERDS2TJ473	1/4W 47K Δ	R803	ERDS2TJ105T	1/4W 1M	R1004	ERDS2TJ103	1/4W 10K
R616	ERDS2TJ684	1/4W 680K	R804	ERDS2TJ104	1/4W 100K	R1005	ERDS2TJ105T	1/4W 1M
R617	ERD2FCV6470T	1/4W 47 Δ	R805	ERDS2TJ223	1/4W 22K	R1006	ERDS2TJ103	1/4W 10K
R618	ERD25FJ101	1/4W 100 Δ	R806	ERDS2TJ471	1/4W 470	R1007, 1008	ERDS2TJ104	1/4W 100K
R619, 620	ERGSJ331P	2W 330	R807	ERDS2TJ822	1/4W 8.2K	R1009, 1010	ERDS2TJ332	1/4W 3.3K
R621	ERDS2TJ684	1/4W 680K Δ	R808	ERDS2TJ563	1/4W 56K	R1011, 1012	ERDS2TJ101	1/4W 100
R622	ERDS2TJ103	1/4W 10K Δ	R809-812	ERDS2TJ102	1/4W 1K	R1013	ERDS2TJ821	1/4W 820
R623	ERDS2TJ154	1/4W 150K Δ	R813, 814	ERDS2TJ122	1/4W 1.2K	R1014-1016	ERDS2TJ103	1/4W 10K
R624	ERDS2TJ223	1/4W 22K	R815, 816	ERDS2TJ152	1/4W 1.5K	R1021-1025	ERDS2TJ103	1/4W 10K
R625	ERDS2TJ103	1/4W 10K	R817, 818	ERDS2TJ182	1/4W 1.8K	R1026	ERDS2TJ105T	1/4W 1M
R626	ERDS1FVJ471T	1/2W 470 Δ	R819	ERDS2TJ222	1/4W 2.2K	R1027	ERDS2TJ472	1/4W 4.7K
R629, 630	ERDS2TJ221	1/4W 220	R820, 821	ERDS2TJ332	1/4W 3.3K	R1028-1030	ERDS2TJ103	1/4W 10K
R651-654	ERDS2TJ223	1/4W 22K	R822, 823	ERDS2TJ472	1/4W 4.7K	R1031	ERDS2TJ105T	1/4W 1M
R655	ERDS2TJ682T	1/4W 6.8K	R824, 825	ERDS2TJ682T	1/4W 6.8K	R1035-1038	ERDS2TJ822	1/4W 8.2K
R656	ERDS2TJ104	1/4W 100K	R826	ERDS2TJ123	1/4W 12K	R1039, 1040	ERDS2TJ333	1/4W 33K
R657	ERDS2TJ103	1/4W 10K	R827	ERDS2TJ103	1/4W 10K	R1041	ERDS2TJ105T	1/4W 1M
R658	ERDS2TJ223	1/4W 22K	R828, 829	ERDS1FVJ331T	1/2W 330 Δ	R1046	ERDS2TJ822	1/4W 8.2K
R659	ERDS2TJ332	1/4W 3.3K	R830	ERDS2TJ102	1/4W 1K	R1048	ERDS2TJ822	1/4W 8.2K
R660	ERDS1FVJ390T	1/2W 39 Δ	R831	ERDS2TJ152	1/4W 1.5K	R1050	ERDS2TJ105T	1/4W 1M
R661	ERDS2TJ220T	1/4W 22	R832	ERDS2TJ390	1/4W 39	R1052	ERDS2TJ333	1/4W 33K
R662	ERDS2TJ222	1/4W 2.2K	R833	ERDS2TJ222	1/4W 2.2K	R1053	ERDS2TJ224T	1/4W 220K
R663	ERDS2TJ103	1/4W 10K	R835, 836	ERDS2TJ824	1/4W 820K	R1054	ERDS2TJ222	1/4W 2.2K
R664, 665	ERDS2TJ333	1/4W 33K	R837, 838	ERDS2TJ154	1/4W 150K	R1056, 1057	ERDS2TJ103	1/4W 10K
R666	ERDS2TJ153	1/4W 15K	R839, 840	ERDS2TJ153	1/4W 15K	R1061-1072	ERDS2TJ822	1/4W 8.2K
R667, 668	ERDS2TJ103	1/4W 10K	R843, 844	ERDS2TJ182				

Ref. No.	Part No.	Values & Remarks	Ref. No.	Part No.	Values & Remarks	Ref. No.	Part No.	Values & Remarks
R1104	ERDS2TJ183T	1/4W 18K	C215	ECKR1H103ZF5	50V 0.01U	C451, 452	ECEA1VKA4R7B	35V 4.7U
R1105, 1106	ERDS2TJ682T	1/4W 6.8K	C216	ECEA1CKA100B	16V 10U	C453, 454	ECBT1H101KB5	50V 100P
R1107-1112	ERDS2TJ474	1/4W 470K	C217	ECEA1HKA010B	50V 1U	C455, 456	ECBT1H102KB5	50V 1000P
R1113-1115	ERDS2TJ332	1/4W 3.3K	C220	ECEA1CKA100B	16V 10U	C457, 458	ECEA1AKA330B	10V 33U
R1116	ERDS2TJ563	1/4W 56K	C221	ECFR1E183KR	25V 0.018U	C459, 460	ECFR1E223KR	25V 0.022U
R1153-1158	ERDS2TJ473	1/4W 47K	C222	ECQV1H473JM3	50V 0.047U	C461, 462	ECFR1E682KR	25V 6800P
R1161	ERDS2TJ394	1/4W 390K	C225	ECBT1H180JC5	50V 18P	C463, 464	ECEA1VKA4R7B	35V 4.7U
R1162	ERDS2TJ152	1/4W 1.5K	C226	ECKR1H103ZF5	50V 0.01U	C465, 466	ECBT1E103ZF	25V 0.01U
R1163-1166	ERDS2TJ224T	1/4W 220K	C227	ECEA1CKA100B	16V 10U	C467, 468	ECBT1H180J5	50V 18P
R1171, 1172	ERDS2TJ103	1/4W 10K	C228	ECBT1H8R2KC5	50V 8.2P E, EB, G, GN	C469, 470	ECBT1H221KB5	50V 220P
R1301, 1302	ERDS2TJ222	1/4W 2.2K	C228	ECBT1H100JC5	50V 10P EG	C501, 502	ECFR1E333KR	25V 0.033U
R1303, 1304	ERDS2TJ563	1/4W 56K	C229	ECBT1H102KB5	50V 1000P	C503, 504	ECEA1HKA3R3B	50V 3.3U
R1307, 1308	ERDS2TJ563	1/4W 56K	C230	ECCR1H680J55	50V 68P	C505, 506	ECBT1H150J5	50V 15P
R1309, 1310	ERDS2TJ332	1/4W 3.3K	C231	ECCR1H820J55	50V 82P	C507, 508	ECBT1H331KB5	50V 330P
R1311	ERDS2TJ684	1/4W 680K	C232	ECBT1H471KB5	50V 470P	C509, 510	ECEA0JKA470B	6.3V 47U
R1313	ERDS2TJ564	1/4W 560K Δ	C251	ECKT1H223ZF	50V 0.022U E, EB, G, GN	C511, 512	ECBT1H680J5	50V 68P
R1314	ERDS2TJ154	1/4W 150K Δ	C252	ECEA1HKA010B	50V 1U E, EB, G, GN	C513, 514	ECBT1E103ZF	25V 0.01U
R1315, 1316	ERD25FVJ4R7T	1/4W 4.7 Δ	C253	ECKT1H223ZF	50V 0.022U E, EB, G, GN	C515, 516	ECEA1HKA3R3B	50V 3.3U
R1317, 1318	ERDS2TJ104	1/4W 100K	C301	ECA1CM101B	16V 100U	C517, 518	ECKR1H103ZF5	50V 0.01U
R1320	ERDS2TJ222	1/4W 2.2K	C302	ECEA1HKA47B	50V 0.47U	C519	ECBT1E103ZF	25V 0.01U
R1321, 1322	ERDS2TJ100	1/4W 10	C303	ECEA1HKA010B	50V 1U	C551, 552	ECEA1HKA3R3B	50V 3.3U
R1323	ERDS2TJ102	1/4W 1K	C304-306	ECEA1HKA3R3B	50V 3.3U	C553-557	ECBT1H101KB5	50V 100P
R1328	ERD25FJ470	1/4W 47 Δ	C307, 308	ECFR1E392KR	25V 3900P	C558	ECBT1H221KB5	50V 220P E, EB, EG
R1424	ERD25FJ470	1/4W 47 Δ	C309	ECKT1H223ZF	50V 0.022U	C558	ECBT1H101KB5	50V 100P G, GN
R2001	ERDS2TJ473	1/4W 47K	C310	ECFR1E473KR	25V 0.047U	C559, 560	ECEA1HKA3R3B	50V 3.3U
R2007, 2008	ERDS2TJ104	1/4W 100K	C311	ECQP1471JZ	100V 470P	C561, 562	ECEA1CKA100B	16V 10U
R2011, 2012	ERDS2TJ223	1/4W 22K	C313, 314	ECBT1H102KB5	50V 1000P	C563	ECBT1H331KB5	50V 330P
R2031, 2032	ERDS2TJ333	1/4W 33K	C321	ECEA1CKA100B	16V 10U	C564, 565	ECBT1H221KB5	50V 220P
R2033, 2034	ERDS2TJ562	1/4W 5.6K	C323, 324	ECFR1E332KR	25V 3300P	C566	ECBT1H331KB5	50V 330P
R2035-2038	ERDS2TJ222	1/4W 2.2K	C325	ECBT1H330J5	50V 33P	C571	ECKR1H103ZF5	50V 0.01U
R2039, 2040	ERDS2TJ562	1/4W 5.6K	C326	ECKR1H103ZF5	50V 0.01U	C581	ECEA1VKA4R7B	35V 4.7U
		CAPACITORS	C327	ECBT1H102KB5	50V 1000P EG	C582	ECBT1H330J5	50V 33P
			C351, 352	ECEA0JKA470B	6.3V 47U	C583	ECEA1HKA010B	50V 1U
			C353	ECBT1H220J5	50V 22P	C584	ECBT1H330J5	50V 33P
C101, 102	ECBT1H150JC5	50V 15P	C354	ECA0JM471B	6.3V 470U	C585	ECEA1HKA2R2B	50V 2.2U
C103	ECBT1H102KB5	50V 1000P	C355	ECBT1H220J5	50V 22P	C586, 587	ECBT1E103ZF	25V 0.01U
C105	ECEA0JKA221B	6.3V 220U	C356	ECA0JM471B	6.3V 470U	C601, 602	ECEA1EKN3R3B	25V 3.3U Δ
C106	ECKR1H103ZF5	50V 0.01U	C357	ECEA1CKA100B	16V 10U	C603, 604	ECKD1H471KB	50V 470P
C107	ECKT1H223ZF	50V 0.022U	C358, 359	ECEA1CKA470B	16V 47U	C605, 606	ECEA1CKN220B	16V 22U Δ
C108	ECEA1EKA4R7B	25V 4.7U	C401	ECEA1VKA4R7B	35V 4.7U	C607, 608	ECCD1H150KC	50V 15P
C109	ECEA1CKA330B	16V 33U	C402	ECBT1E103ZF	25V 0.01U	C609, 610	ECCR1H221K5	50V 220P
C110, 111	ECBT1H102KB5	50V 1000P	C403, 404	ECEA1VKA4R7B	35V 4.7U	C611, 612	ECQV1H473JM3	50V 0.047U
C201, 202	ECKR1H103ZF5	50V 0.01U	C405, 406	ECBT1H101KB5	50V 100P	C613	ECA1HM470B	50V 47U
C204	ECBT1C103MS5	16V 0.01U	C407	ECA0JAP101B	6.3V 100U	C614	ECA1JM330B	63V 33U
C205	ECKT1H223ZF	50V 0.022U	C408	ECBT1H331KB5	50V 330P	C615	ECEA2AU100	100V 10U
C206	ECBT1H150JC5	50V 15P	C409, 410	ECEA1CKA220B	16V 22U	C616	ECEA2AN2R2SB	100V 2.2U Δ
C207	ECBT1C103MS5	16V 0.01U	C411, 412	ECBT1H101KB5	50V 100P	C619, 620	ECBT1H331KB5	50V 330P
C208	ECEA0JKA101B	6.3V 100U	C413, 414	ECEA1CKA100B	16V 10U	C621-624	ECKT1H223ZF	50V 0.022U
C209	ECEA1HKA100B	50V 10U	C415, 416	ECBT1E103ZF	25V 0.01U	C625-627	ECKR1H103ZF5	50V 0.01U
C210-212	ECKT1H223ZF	50V 0.022U	C417, 418	ECBT1H101KB5	50V 100P	C651	ECEA1HKA2R2B	50V 2.2U
C213	ECBT1H101KB5	50V 100P	C419-422	ECBT1H331KB5	50V 330P	C652	ECEA1CKA100B	16V 10U
C214	ECEA1CKA100B	16V 10U	C423-428	ECBT1H101KB5	50V 100P	C653	ECBT1E223ZF	25V 0.022U

Ref. No.	Part No.	Values & Remarks	Ref. No.	Part No.	Values & Remarks	Ref. No.	Part No.	Values & Remarks
C654	ECEA1CKA470B	16V 47U	C913, 914	ECEA1VKA100B	35V 10U	C1089	ECAOJM102B	6.3V 1000U
C655	ECEAOJKA221B	6.3V 220U	C916	ECEA1HKA010B	50V 1U	C1103-1110	ECEA1HKA3R3B	50V 3.3U
C701	ECKR1H103ZF5	50V 0.01U	C918	ECBT1H101KB5	50V 100P	C1111, 1112	ECEA1CKA470B	16V 47U
C702	ECQE2104KF3	250V 0.1U △	C971	ECKR1H103ZF5	50V 0.01U	C1113, 1114	ECBT1E103ZF	25V 0.01U
C703, 704	ECES71V103VN	71V 10000U △	C1001	ECBT1E103ZF	25V 0.01U	C1115-1117	ECBT1H181KB5	50V 180P
C705	ECKR2H103ZU	500V 0.01U △	C1002	ECBT1H330J5	50V 33P	C1153, 1154	ECEA1HKA3R3B	50V 3.3U
C706	ECA1HM102E	50V 1000U △	C1003	ECBT1E103ZF	25V 0.01U	C1157, 1158	ECEA1HKA3R3B	50V 3.3U
C707	ECA1VM101B	35V 100U	C1004	ECEAOJKA221B	6.3V 220U	C1161, 1162	ECEA1CKA100B	16V 10U
C708	ECKR1H103ZF5	50V 0.01U	C1005, 1006	ECBT1E103ZF	25V 0.01U	C1164	ECEA1EKA4R7B	25V 4.7U
C709	ECEA1CKA330B	16V 33U	C1007	ECBT1E223ZF	25V 0.022U	C1301, 1302	ECEA1HKA3R3B	50V 3.3U
C710	ECKR1H103ZF5	50V 0.01U	C1008, 1009	ECEA1CKA100B	16V 10U	C1303, 1304	ECBA1H681KB5	50V 680P
C711	ECKR1H103ZF5	50V 0.01U △	C1010, 1011	ECQB1H332JF3	50V 3300P	C1305, 1306	ECBT1H821KB5	50V 820P
C712	ECA1HM470B	50V 47U △	C1012	ECEAOJKA221B	6.3V 220U	C1307, 1308	ECEA1HU220	50V 22U
C713	ECKR1H103ZF5	50V 0.01U △	C1013	ECBT1E103ZF	25V 0.01U	C1309, 1310	ECBT1H100JC5	50V 10P
C714	ECEA1HKA4R7B	50V 4.7U	C1014	ECBT1E223ZF	25V 0.022U	C1311	ECEA2AU100	100V 10U
C715	ECEA1CKA470B	16V 47U △	C1015, 1016	ECBT1E103ZF	25V 0.01U	C1312	ECEA1JU220	63V 22U
C716	ECQE2104KF3	250V 0.1U △	C1017	ECEAOJKA101B	6.3V 100U	C1313, 1314	ECBT1H223ZF	50V 0.022U
C751	ECKWNS103ZVS	500V 0.01U △	C1018-1020	ECBT1H821KB5	50V 820P	C1315, 1316	ECEA1WJ332	35V 3300U △
C752	ECKR1H103ZF5	50V 0.01U △	C1021	ECBT1H101KB5	50V 100P	C1317	ECKR2H103ZU	500V 0.01U △
C753	ECA1EM102E	25V 1000U	C1022	ECBT1H680J5	50V 68P	C2001, 2002	ECEA1HKA3R3B	50V 3.3U
C754	ECBT1E103ZF	25V 0.01U	C1023	ECQV1H154JM3	50V 0.15U	C2005-2007	ECEA1CKA100B	16V 10U
C755	ECEA1EKA220B	25V 22U	C1024-1026	ECEA1CKA100B	16V 10U	C2008	ECEA1HKA100B	50V 10U
C756	ECKR1H103ZF5	50V 0.01U	C1027	ECBT1E103ZF	25V 0.01U	C2009-2012	ECQB1H333JF3	50V 0.039U
C757	ECEA1CKA470B	16V 47U	C1028	ECEAOJKA221B	6.3V 220U	C2013-2016	ECBT1C103KS5	16V 0.01U
C758	ECEA1AKA101B	10V 100U	C1029	ECA1AM102B	10V 1000U	C2017-2020	ECBT1C222KR5	16V 2200P
C801	ECA1AM102B	10V 1000U	C1031, 1032	ECBT1H330J5	50V 33P	C2021-2024	ECBT1H102KB5	50V 1000P
C802	ECBT1E103ZF	25V 0.01U	C1033, 1034	ECFR1E272KR	25V 2700P	C2025, 2026	ECEAOJKA101B	6.3V 100U
C803	ECA1AM102B	10V 1000U	C1035, 1036	ECBT1H391KB5	50V 390P	C2027	ECBT1E103ZF	25V 0.01U
C804	ECAOJM102B	6.3V 1000U	C1037, 1038	ECQB1H682JF3	50V 6800P	C2028	ECEAOJKA101B	6.3V 100U
C805	ECEAOJKA221B	6.3V 220U	C1039	ECEA1CKA100B	16V 10U	C2029, 2030	ECBT1E103ZF	25V 0.01U
C806	ECBT1E103ZF	25V 0.01U	C1040	ECBT1E103ZF	25V 0.01U	C2031, 2032	ECBT1H331KB5	50V 330P
C807, 808	ECEA1HKA47B	50V 0.47U	C1042	ECBT1H330J5	50V 33P	C2037-2040	ECEA1HKA3R3B	50V 3.3U
C809	ECEAOJKA470B	6.3V 47U	C1044	ECBT1H221KB5	50V 220P	C2041	ECEA1CKA100B	16V 10U
C810	ECKR1H103ZF5	50V 0.01U	C1045	ECFR1E182KR	25V 1800P	C2051, 2052	ECBT1E103ZF	25V 0.01U
C811-814	ECBT1E103ZF	25V 0.01U	C1046	ECFR1E272KR	25V 2700P			
C815	ECEA1CKA470B	16V 47U	C1048	ECEA1HKA010B	50V 1U			
C816	ECEA1CKA100B	16V 10U	C1051, 1052	ECBT1E103ZF	25V 0.01U			
C817, 818	ECBT1H102KB5	50V 1000P	C1055, 1056	ECEA1HKA010B	50V 1U			
C819	ECFR1E102KR	25V 1000P	C1057, 1058	ECBT1H391KB5	50V 390P			
C820	ECEA1CKA470B	16V 47U	C1059, 1060	ECQB1H682JF3	50V 6800P			
C821, 822	ECEA1HKA3R3B	50V 3.3U	C1061, 1062	ECFR1E272KR	25V 2700P			
C823, 824	ECEA1HKA010B	50V 1U	C1063, 1064	ECQB1H682JF3	50V 6800P			
C851, 852	ECEAOJKA101B	6.3V 100U	C1065, 1066	ECBT1H391KB5	50V 390P			
C853, 854	ECFR1E104KR	25V 0.1U	C1067, 1068	ECFR1E272KR	25V 2700P			
C855	ECBT1H101KB5	50V 100P	C1069, 1070	ECEA1CKA100B	16V 10U			
C891	ECFR1E392KR	25V 3900P	C1075, 1076	ECBT1H101KB5	50V 100P			
C901	ECA1AM102B	10V 1000U	C1077, 1078	ECEA1CKA100B	16V 10U			
C902	ECBT1E103ZF	25V 0.01U	C1079, 1080	ECEA1EKA4R7B	25V 4.7U			
C904, 905	ECAOJM102B	6.3V 1000U	C1081, 1082	ECBT1H680J5	50V 68P			
C906	ECBT1E103ZF	25V 0.01U	C1085, 1086	ECBT1E103ZF	25V 0.01U			
C909, 910	ECBT1H101KB5	50V 100P	C1087	ECBT1H331KB5	50V 330P			
C911, 912	ECEA2AU100	100V 10U △	C1088	ECBT1H101KB5	50V 100P			