

Service Manual

DVD Home Theater Sound System



SA-HT340E
SA-HT340EB
SA-HT340EG

Colour

(S).....Silver Type

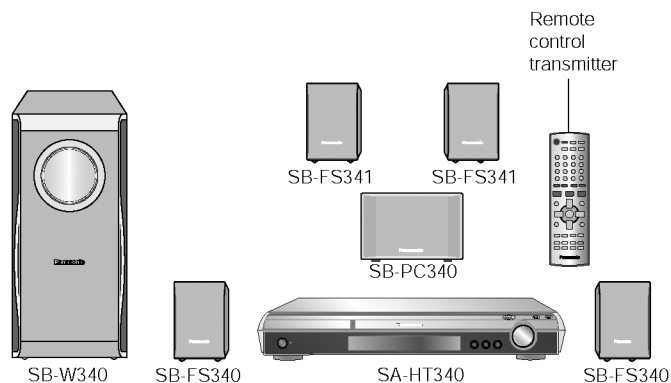

Specifications

IGeneral

Power Source:

E/ EG areas:	AC 230V, 50Hz
EB area:	AC 230V-240V, 50Hz

Power consumption: 90 W

Dimensions (W×H×D): 430×60×342 mm

Mass: 3kg

IAmplifier section

RMS Output Power: Dolby Digital Mode

ITotal RMS Dolby Digital mode Power: 330 W

At 1kHz and total harmonic of 10%

IFront:	55 W/ Channel (5Ω)
ICenter:	55 W/ Channel (5Ω)
ISurround:	55 W/ Channel (5Ω)

At 100Hz and total harmonic of 10%

IActive subwoofers: 55 W/ Channel (5Ω)

DIN Output Power: Dolby Digital Mode:

ITotal DIN Dolby Digital mode Power: 150 W

At 1kHz and total harmonic of 1%

IFront:	25 W/ Channel (5Ω)
ICenter:	25 W/ Channel (5Ω)
ISurround:	25 W/ Channel (5Ω)

At 100Hz and total harmonic of 1%

ISubwoofer: 25 W/ Channel (5Ω)

IFM tuner section (FM)

Preset Memory: FM 15 stations
AM/MW 15 stations

Frequency Range: 87.5-108.00MHz
(50kHz step)

Sensitivity: 1.8μV (IHF)

S/N 26dB 1.4μV

Antenna Terminals: 75Ω (unbalanced)

IAM tuner section (AM/MW)

Frequency Range: 522-1629kHz (9kHz step)

AM Sensitivity S/N 20dB at

999kHz: 560μV/m

IDisc section

Discs played (8 cm or 12 cm):

- (1) DVD [DVD-Video, DivX(*6,7)]
- (2) DVD-RAM [DVD-VR, MP3(*2,7), JPEG(*4,7), MPEG4(*5,7), DivX(*6,7)]
- (3) DVD-R [DVD-Video, DVD-VR, MP3(*2,7), JPEG(*4,7), MPEG4(*5,7), DivX(*6,7)]
- (4) DVD-R DL [DVD-Video, DVD-VR]
- (5) DVD-RW [DVD-Video, DVD-VR, MP3(*2,7), JPEG(*4,7), MPEG4(*5,7), DivX(*6,7)]
- (6) +R/RW [Video]

Panasonic®

© 2006 Panasonic AVC Networks Singapore Pte. Ltd. All rights reserved. Unauthorized copying and distribution is a violation of law.

- (7) +R DL [Video]
- (8) CD, CD-R/RW [CD-DA, Video CD, SVCD(*1), MP3(*2,7), WMA(*3,7), JPEG(*4,7), MPEG4(*5,7), DivX (*6,7), HighMAT Level 2 (Audio and Image)]
- *1 Conforming to IEC62107
- *2 MPEG-1 Layer 3, MPEG-2 Layer 3
- *3 Windows Media Audio Ver.9.0 L3
INot compatible with Multiple Bit Rate (MBR)
- *4 Exif Ver 2.1 JPEG Baseline files
IPicture resolution: between 160 x 120 and 6144 x 4096 pixels (Sub sampling is 4:0:0, 4:2:0, 4:2:2, 4:4:4). Extremely long and narrow pictures may not be displayed.
- *5 MPEG4 data recorded with Panasonic SD multi cameras or DVD video recorders.
IConforming to SD VIDEO specifications (ASF standard)/MPEG4 (Simple Profile) video system/G.726 audio system.
- *6 Plays all versions of DivX® video (including DivX®6) with standard playback of DivX® media files. Certified to the DivX Home Theater Profile.
IGMC (Global Motion Compensation) is not supported.
- *7 The total combined maximum number of recognizable audio, picture and video contents and groups: 4000 audio, picture and video contents and 400 groups.

Pick up:**Wavelength:**

ICD: 785nm
IDVD: 662nm

Laser power:

ICD: CLASS 1M
IDVD: CLASS 1

Audio output (DISC):

Number of channels: 5.1 ch (FL, FR, C, SL, SR, SW)

Audio performance:**Frequency response:**

DVD (linear audio): 4 Hz-22 kHz (48 kHz sampling)
4 Hz-44 kHz (96 kHz sampling)

CD-Audio: 4 Hz-20 kHz

S/N ratio:

CD-Audio: 105 dB

Dynamic range:

DVD (linear audio): 95 dB

CD-Audio: 95 dB

Total harmonic distortion:

CD-Audio: 0.005 %

IVideo section**Video system:**

Signal system: PAL 625/50, PAL 525/60, NTSC

Composite video output:

Output level: 1 Vp-p (75 Ω)

Terminal: Scart jack (1 system)

S-video output:

Y output level: 1 Vp-p (75 Ω)

C output level: PAL; 0.3Vp-p (75Ω)
NTSC; 0.286 Vp-p (75 Ω)

Terminal Scart jack (1 system)

RGB video output:

R output level: 0.7 Vp-p (75 Ω)

G output level: 0.7 Vp-p (75 Ω)

B output level: 0.7 Vp-p (75 Ω)

Terminal: Scart jack (1 system)

Power consumption in standby mode:

approx 1W

Note:

- Specifications are subject to change without notice. Mass and dimensions are approximate.
- Total harmonic distortion is measured by the digital spectrum analyzer.

Solder:

This model uses lead free solder (PbF).

Mechanism:

This model uses DL2SU (Single tray) mechanism.

Power Supply:

This model uses Switching Mode Power Supply (SMPS) Module for power-up unit.

System	SC-HT340E	SC-HT340EB	SC-HT340EG
Main unit	SA-HT340E	SA-HT340EB	SA-HT340EG
Speaker system	SB-HT340E	SB-HT340E	SB-HT340E

Speaker system	SB-HT340E
Front speakers	SB-FS340E ^{*1}
Center speaker	SB-PC340E ^{*2}
Surround speakers	SB-FS341E ^{*3}
Active subwoofer	SB-W340E ^{*4}

Refer to original service manual for *1, *2, *3, *4.

MPEG Layer-3 audio decoding technology licensed from Fraunhofer IIS and Thomson multimedia.

This product incorporates copyright protection technology that is protected by method claims of certain U.S. patents and other intellectual property rights owned by Macrovision Corporation and other rights owners. Use of this copyright protection technology must be authorized by Macrovision Corporation, and is intended for home and other limited viewing uses only unless otherwise authorized by Macrovision Corporation. Reverse engineering or disassembly is prohibited.

Windows Media, and the Windows logo are trademarks, or registered trademarks of Microsoft Corporation in the United States and/or other countries.

WMA is a compression format developed by Microsoft Corporation. It achieves the same sound quality as MP3 with a file size that is smaller than that of MP3.



HighMAT™ and the HighMAT logo are either trademarks or registered trademarks of Microsoft Corporation in the United States and/or other countries.

[HDCD], HDCD®, High Definition Compatible Digital® and Pacific Microsonics™ are either registered trademarks or trademarks of Pacific Microsonics, Inc. in the United States and/or other countries.

HDCD system manufactured under license from Pacific Microsonics, Inc. This product is covered by one or more of the following: In the USA: 5,479,168, 5,638,074, 5,640,161, 5,808,574, 5,838,274, 5,854,600, 5,864,311, 5,872,531, and in Australia: 669114, with other patents pending.

This product is licensed under the MPEG-4 Visual patent portfolio license for the personal and non-commercial use of a consumer for (i) encoding video in compliance with the MPEG-4 Visual Standard ("MPEG-4 Video") and/or (ii) decoding MPEG-4 Video that was encoded by a consumer engaged in a personal and non-commercial activity and/or was obtained from a video provider licensed by MPEG LA to provide MPEG-4 Video. No license is granted or shall be implied for any other use. Additional information including that relating to promotional, internal and commercial uses and licensing may be obtained from MPEG LA, LLC. See <http://www.mpegla.com>.

Official DivX® Certified product.

Plays all versions of DivX® video (including DivX®6) with standard playback of DivX® media files.



DivX, DivX Certified, and associated logos are trademarks of DivX, Inc. and are used under license.

■ Built-in decoders

You can play discs with these symbols.



⚠ WARNING

This service information is designed for experienced repair technicians only and is not designed for use by the general public. It does not contain warnings or cautions to advise non-technical individuals of potential dangers in attempting to service a product. Products powered by electricity should be serviced or repaired only by experienced professional technicians. Any attempt to service or repair the product or products dealt with in this service information by anyone else could result in serious injury or death.

CONTENTS

	Page		Page
1 Safety Precautions	5	11 Assembly and disassembly of Mechanism Unit	35
1.1. GENERAL GUIDELINES	5	11.1. Disassembly Procedure	35
1.2. Before Repair and Adjustment (Using SMPS)	5	12 Measurements and Adjustments	41
1.3. Protection Circuitry	5	12.1. Service Tools and Equipment	41
1.4. Caution for AC Cord	6	12.2. Important points in adjustment	41
2 Prevention of Electro Static Discharge (ESD) to Electrostatically Sensitive (ES) Devices	7	12.3. Storing and handling of test discs	41
3 Precaution of Laser Diode	8	12.4. Optical adjustment	42
4 About Lead Free Solder (PbF)	9	13 Abbreviations	43
4.1. Service caution based on legal restrictions	9	14 Voltage and Waveform Chart	45
5 Handling Precautions for Traverse Unit	10	14.1. DVD Module P.C.B.	45
5.1. Cautions to Be Taken in Handling the Optical Pickup Unit	10	14.2. Main P.C.B.	46
5.2. Grounding for electrostatic breakdown prevention	10	14.3. FL P.C.B. & Tray Loading P.C.B.	47
6 Accessories	12	14.4. SMPS Module P.C.B.	47
7 Operation Procedures	13	14.5. Waveform Chart	48
7.1. Remote Control Keys Operation	13	15 Illustration of IC's, Transistors and Diodes	49
7.2. Main Unit Keys Operation	14	16 Wiring Connection Diagram	51
7.3. Connection Setup	15	17 Block Diagram	53
7.4. Disc information	16	18 Schematic Notes	59
7.5. About DivX VOD Content	18	19 Schematic Diagram	61
8 Self-Diagnosis and special mode setting	19	19.1. (A) DVD Module (DV3.2) Circuit	61
8.1. Service Mode Summary Table	19	19.2. (B) Main/FL/Volume/Tray Loading/Tuner Extent Circuit ..	65
8.2. Service Mode Table 1	19	20 Printed Circuit Board	71
8.3. DVD Self Diagnostic Function-Error Code	24	20.1. (A) DVD Module P.C.B.	71
8.4. Sales Demonstration Lock Function	26	20.2. (B) Main/Power P.C.B.	72
8.5. Service Precautions	27	20.3. (C) FL, Volume, Tuner Extent, & Tray Loading P.C.B. --	73
9 Assembling and Disassembling	28	21 Basic Troubleshooting Guide	75
9.1. Disassembly Flow Chart	29	21.1. Basic Troubleshooting Guide for Traverse Unit (DVD Module P.C.B.)	75
9.2. Main Components and P.C.B. Locations	29	21.2. Troubleshooting Guide for Power section (Power circuit)75	75
9.3. Disassembly of Top Cabinet	30	22 Overall Block (HT340)	76
9.4. Disassembly of the DVD Lid (When taking out disc manually)	30	22.1. HT340 DVD Unit Block	77
9.5. Disassembly of Front Panel Assembly	31	22.2. HT340 Block (Analog Signal : DVD 5.1ch Play Back Mode)	78
9.6. Disassembly of FL P.C.B. & Volume P.C.B.	31	22.3. HT340 Block (Analog Signal : 2ch Analog Input Mode) --	79
9.7. Disassembly of DVD Mechanism Unit	32	22.4. HT340 Power Supply Block	80
9.8. Disassembly of DVD Module P.C.B.	32	22.5. HT340 Power (Main) Block	81
9.9. Disassembly of Rear panel	33	23 Terminal Function of ICs	82
9.10. Disassembly of SMPS Module P.C.B.	33	23.1. IC2018 (C2CBBY000194): System Control Microprocessor IC	82
9.11. Disassembly of Main P.C.B. & Tuner Extent P.C.B.	33	24 Exploded Views	83
9.12. Disassembly of Digital Amp IC	33	24.1. Cabinet Parts Location	83
10 Service Position	34	24.2. Packaging	85
10.1. Servicing position of the DVD Module P.C.B.	34	25 Replacement Parts List	86
10.2. Servicing position of the Main P.C.B.	34	25.1. Component Parts List	87
10.3. Servicing position of the SMPS Module P.C.B.	34		

1 Safety Precautions

1.1. GENERAL GUIDELINES

1. When servicing, observe the original lead dress. If a short circuit is found, replace all parts which have been overheated or damaged by the short circuit.
2. After servicing, see to it that all the protective devices such as insulation barriers, insulation papers shields are properly installed.
3. After servicing, carry out the following leakage current checks to prevent the customer from being exposed to shock hazards.

1.1.1. LEAKAGE CURRENT COLD CHECK

1. Unplug the AC cord and connect a jumper between the two prongs on the plug.
2. Measure the resistance value, with an ohmmeter, between the jumpered AC plug and each exposed metallic cabinet part on the equipment such as screwheads, connectors, control shafts, etc. When the exposed metallic part has a return path to the chassis, the reading should be between $1M\Omega$ and $5.2M\Omega$.
When the exposed metal does not have a return path to the chassis, the reading must be ∞ .

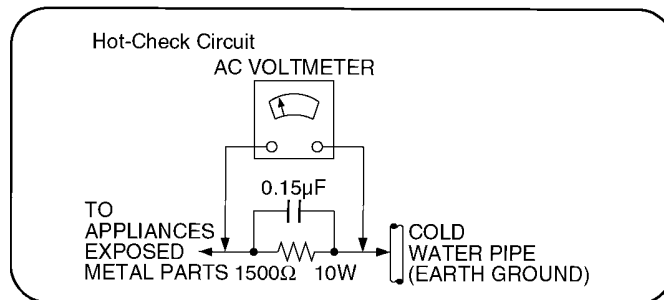

Figure 1

1.1.2. LEAKAGE CURRENT HOT CHECK (See Figure 1.)

1. Plug the AC cord directly into the AC outlet. Do not use an isolation transformer for this check.
2. Connect a $1.5k\Omega$, 10 watts resistor, in parallel with a $0.15\mu\text{F}$ capacitors, between each exposed metallic part on the set and a good earth ground such as a water pipe, as shown in Figure 1.
3. Use an AC voltmeter, with 1000 ohms/volt or more sensitivity, to measure the potential across the resistor.
4. Check each exposed metallic part, and measure the voltage at each point.
5. Reverse the AC plug in the AC outlet and repeat each of the above measurements.
6. The potential at any point should not exceed 0.75 volts RMS. A leakage current tester (Simpson Model 229 or equivalent) may be used to make the hot checks, leakage current must not exceed 1/2 milliamp. In case a measurement is outside of the limits specified, there is a possibility of a shock hazard, and the equipment should be repaired and rechecked before it is returned to the customer.

1.2. Before Repair and Adjustment (Using SMPS)

This model uses Switching Mode Power Supply (SMPS) Module to provide the necessary voltages for the unit. DO NOT SHORT-CIRCUIT DIRECTLY (with a screwdriver blade, for instance), as this may destroy solid state devices. After repairs are completed, restore power gradually using a variac, to avoid overcurrent. Current consumption at AC 230 V, 50 Hz in NO SIGNAL mode volume minimal should be ~ 650 mA. (For E/EG) Current consumption at AC 230V~240V, 50 Hz in NO SIGNAL mode volume minimal should be ~ 650 mA. (For EB)

1.3. Protection Circuitry

The protection circuitry may have operated if either of the following conditions are noticed:

- No sound is heard when the power is turned on.
- Sound stops during a performance.

The function of this circuitry is to prevent circuitry damage if, for example, the positive and negative speaker connection wires are "shorted", or if speaker systems with an impedance less than the indicated rated impedance of the amplifier are used.

If this occurs, follow the procedure outlines below:

1. Turn off the power.
2. Determine the cause of the problem and correct it.
3. Turn on the power once again after one minute.

Note:

When the protection circuitry functions, the unit will not operate unless the power is first turned off and then on again.

1.4. Caution for AC Cord

**(For United Kingdom)
("EB"area code model only)**

For your safety, please read the following text carefully. This appliance is supplied with a moulded three pin mains plug for your safety and convenience.

A 5-ampere fuse is fitted in this plug.

Should the fuse need to be replaced please ensure that the replacement fuse has a rating of 5-ampere and that it is approved by ASTA or BSI to BS1362.

Check for the ASTA mark  or the BSI mark  on the body of the fuse.

If the plug contains a removable fuse cover you must ensure that it is refitted when the fuse is replaced.

If you lose the fuse cover the plug must not be used until a replacement cover is obtained.

A replacement fuse cover can be purchased from your local dealer.

CAUTION!

IF THE FITTED MOULDED PLUG IS UNSUITABLE FOR THE SOCKET OUTLET IN YOUR HOME THEN THE FUSE SHOULD BE REMOVED AND THE PLUG CUT OFF AND DISPOSED OF SAFELY. THERE IS A DANGER OF SEVERE ELECTRICAL SHOCK IF THE CUT OFF PLUG IS INSERTED INTO ANY 13-AMPERE SOCKET.

If a new plug is to be fitted please observe the wiring code as stated below.

If in any doubt please consult a qualified electrician.

IMPORTANT

The wires in this mains lead are coloured in accordance with the following code:

Blue: Neutral, Brown: Live.

As these colours may not correspond with the coloured markings identifying the terminals in your plug, proceed as follows:

The wire which is coloured Blue must be connected to the terminal which is marked with the letter N or coloured Black or Blue.

The wire which is coloured Brown must be connected to the terminal which is marked with the letter L or coloured Brown or Red.

WARNING: DO NOT CONNECT EITHER WIRE TO THE EARTH TERMINAL WHICH IS MARKED WITH THE LETTER E, BY THE EARTH SYMBOL \perp OR COLOURED GREEN OR GREEN/YELLOW.

THIS PLUG IS NOT WATERPROOF— KEEP DRY.

Before use

Remove the connector cover.

How to replace the fuse

The location of the fuse differ according to the type of AC mains plug (figures A and B). Confirm the AC mains plug fitted and follow the instructions below.

Illustrations may differ from actual AC mains plug.

1. Open the fuse cover with a screwdriver.

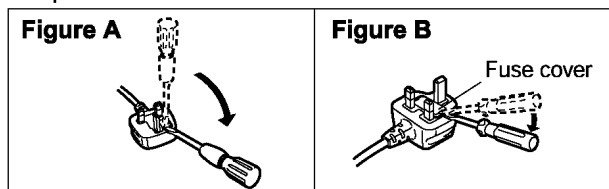

2. Replace the fuse and close or attach the fuse cover.

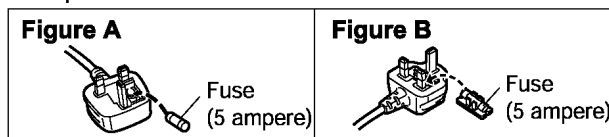

2 Prevention of Electro Static Discharge (ESD) to Electrostatically Sensitive (ES) Devices

Some semiconductor (solid state) devices can be damaged easily by static electricity. Such components commonly are called Electrostatically Sensitive (ES) Devices. Examples of typical ES devices are integrated circuits and some field-effect transistors and semiconductor "chip" components. The following techniques should be used to help reduce the incidence of component damage caused by electro static discharge (ESD).

1. Immediately before handling any semiconductor component or semiconductor-equipped assembly, drain off any ESD on your body by touching a known earth ground. Alternatively, obtain and wear a commercially available discharging ESD wrist strap, which should be removed for potential shock reasons prior to applying power to the unit under test.
2. After removing an electrical assembly equipped with ES devices, place the assembly on a conductive surface such as aluminum foil, to prevent electrostatic charge buildup or exposure of the assembly.
3. Use only a grounded-tip soldering iron to solder or unsolder ES devices.
4. Use only an anti-static solder removal device. Some solder removal devices not classified as "anti-static (ESD protected)" can generate electrical charge sufficient to damage ES devices.
5. Do not use freon-propelled chemicals. These can generate electrical charges sufficient to damage ES devices.
6. Do not remove a replacement ES device from its protective package until immediately before you are ready to install it. (Most replacement ES devices are packaged with leads electrically shorted together by conductive foam, aluminum foil or comparable conductive material).
7. Immediately before removing the protective material from the leads of a replacement ES device, touch the protective material to the chassis or circuit assembly into which the device will be installed.

Caution

Be sure no power is applied to the chassis or circuit, and observe all other safety precautions.

8. Minimize bodily motions when handling unpackaged replacement ES devices. (Otherwise harmless motion such as the brushing together of your clothes fabric or the lifting of your foot from a carpeted floor can generate static electricity (ESD) sufficient to damage an ES device).

IMPORTANT SAFETY NOTICE

There are special components used in this equipment which are important for safety. These parts are marked by \triangle in the schematic diagrams, Exploded Views and replacement parts list. It is essential that these critical parts should be replaced with manufacturer's specified parts to prevent shock, fire, or other hazards. Do not modify the original design without permission of manufacturer.

3 Precaution of Laser Diode

CAUTION: This product utilizes a laser diode with the unit turned "on", invisible laser radiation is emitted from the pick-up lens.
Wave length:662nm(DVD)/785nm(CD)
Maximum output radiation power from pick-up: 100 μ W/VDE

Laser radiation from the pick-up unit is safety level, but be sure the followings:

1. Do not disassemble the pick-up unit, since radiation from exposed laser diode is dangerous.
2. Do not adjust the variable resistor on the pick-up unit. It was already adjusted.
3. Do not look at the focus lens using optical instruments.
4. Recommend not to look at pick-up lens for a long time.

ACHTUNG: Dieses Produkt enthält eine Laserdiode. Im eingeschalteten Zustand wird unsichtbare Laserstrahlung von der Lasereinheit abgestrahlt.

Wellenlänge:662nm(DVD)/785nm(VCD/CD)
Maximale Strahlungsleistung der Lasereinheit: 100 μ W/VDE

Die strahlung der Lasereinheit ist ungefährlich, wenn folgende Punkte beachtet werden:

1. Die Lasereinheit nicht zerlegen, da die Strahlung an der freigelegten Laserdiode gefährlich ist.
2. Den werksseitig justierten Einstellregler der Lasereinheit nicht verstellen.
3. Nicht mit optischen Instrumenten in die Fokussierlinse blicken.
4. Nicht über längere Zeit in die Fokussierlinse blicken.

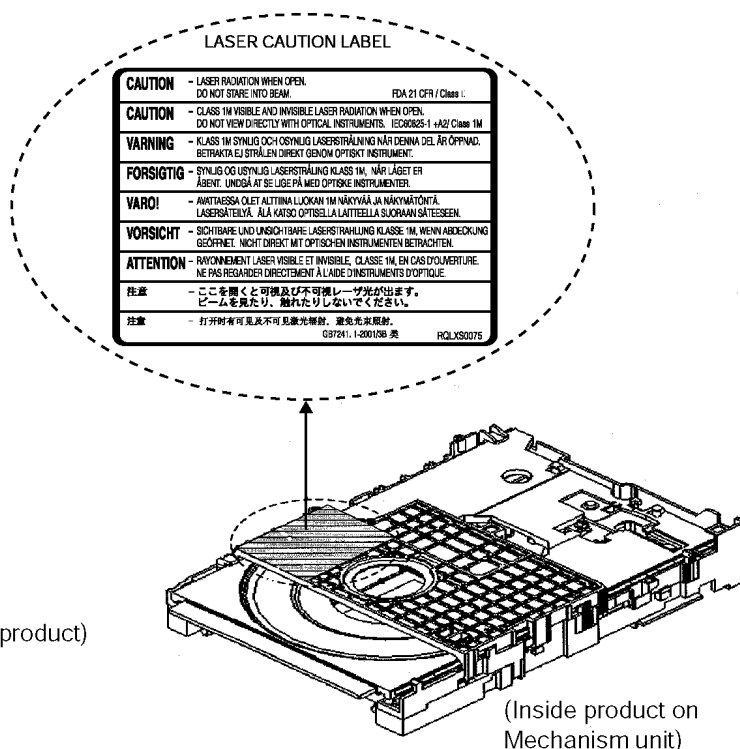
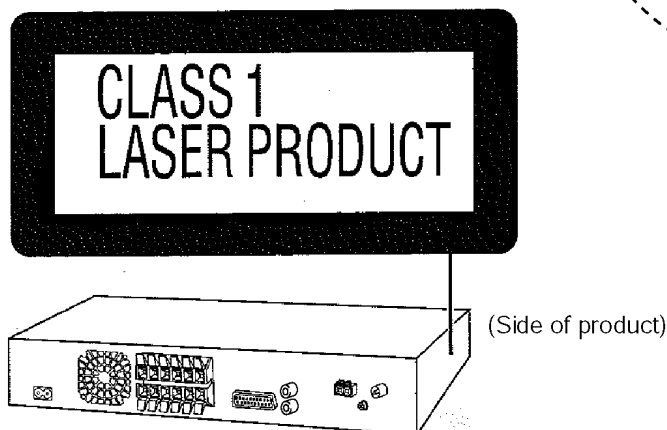

CAUTION:
THIS PRODUCT UTILIZES A LASER.
USE OF CONTROLS OR ADJUSTMENTS OR PERFORMANCE OF PROCEDURES OTHER THAN THOSE SPECIFIED HEREIN MAY RESULT IN HAZARDOUS RADIATION EXPOSURE.

4 About Lead Free Solder (PbF)

4.1. Service caution based on legal restrictions

4.1.1. General description about Lead Free Solder (PbF)

The lead free solder has been used in the mounting process of all electrical components on the printed circuit boards used for this equipment in considering the globally environmental conservation.

The normal solder is the alloy of tin (Sn) and lead (Pb). On the other hand, the lead free solder is the alloy mainly consists of tin (Sn), silver (Ag) and Copper (Cu), and the melting point of the lead free solder is higher approx.30 degrees C (86°F) more than that of the normal solder.

Definition of PCB Lead Free Solder being used

The letter of "PbF" is printed either foil side or components side on the PCB using the lead free solder. (See right figure)	PbF

Service caution for repair work using Lead Free Solder (PbF)

- The lead free solder has to be used when repairing the equipment for which the lead free solder is used.
(Definition: The letter of "PbF" is printed on the PCB using the lead free solder.)
- To put lead free solder, it should be well molten and mixed with the original lead free solder.
- Remove the remaining lead free solder on the PCB cleanly for soldering of the new IC.
- Since the melting point of the lead free solder is higher than that of the normal lead solder, it takes the longer time to melt the lead free solder.
- Use the soldering iron (more than 70W) equipped with the temperature control after setting the temperature at 350±30 degrees C (662±86°F).

Recommended Lead Free Solder (Service Parts Route.)

- The following 3 types of lead free solder are available through the service parts route.
- RFKZ03D01K----- (0.3mm 100g Reel)
 RFKZ06D01K----- (0.6mm 100g Reel)
 RFKZ10D01K----- (1.0mm 100g Reel)

Note

- * Ingredient: tin (Sn), 96.5%, silver (Ag) 3.0%, Copper (Cu) 0.5%, Cobalt (Co) / Germanium (Ge) 0.1 to 0.3%

5 Handling Precautions for Traverse Unit

The laser diode in the optical pickup unit may break down due to static electricity of clothes or human body. Special care must be taken avoid caution to electrostatic breakdown when servicing and handling the laser diode.

5.1. Cautions to Be Taken in Handling the Optical Pickup Unit

The laser diode in the optical pickup unit may be damaged due to electrostatic discharge generating from clothes or human body. Special care must be taken avoid caution to electrostatic discharge damage when servicing the laser diode.

1. Do not give a considerable shock to the optical pickup unit as it has an extremely high-precise structure.
2. To prevent the laser diode from the electrostatic discharge damage, the flexible cable of the optical pickup unit removed should be short-circuited with a short pin or a clip.
3. The flexible cable may be cut off if an excessive force is applied to it. Use caution when handling the flexible cable.
4. The antistatic FPC is connected to the new optical pickup unit. After replacing the optical pickup unit and connecting the flexible cable, cut off the antistatic FPC.

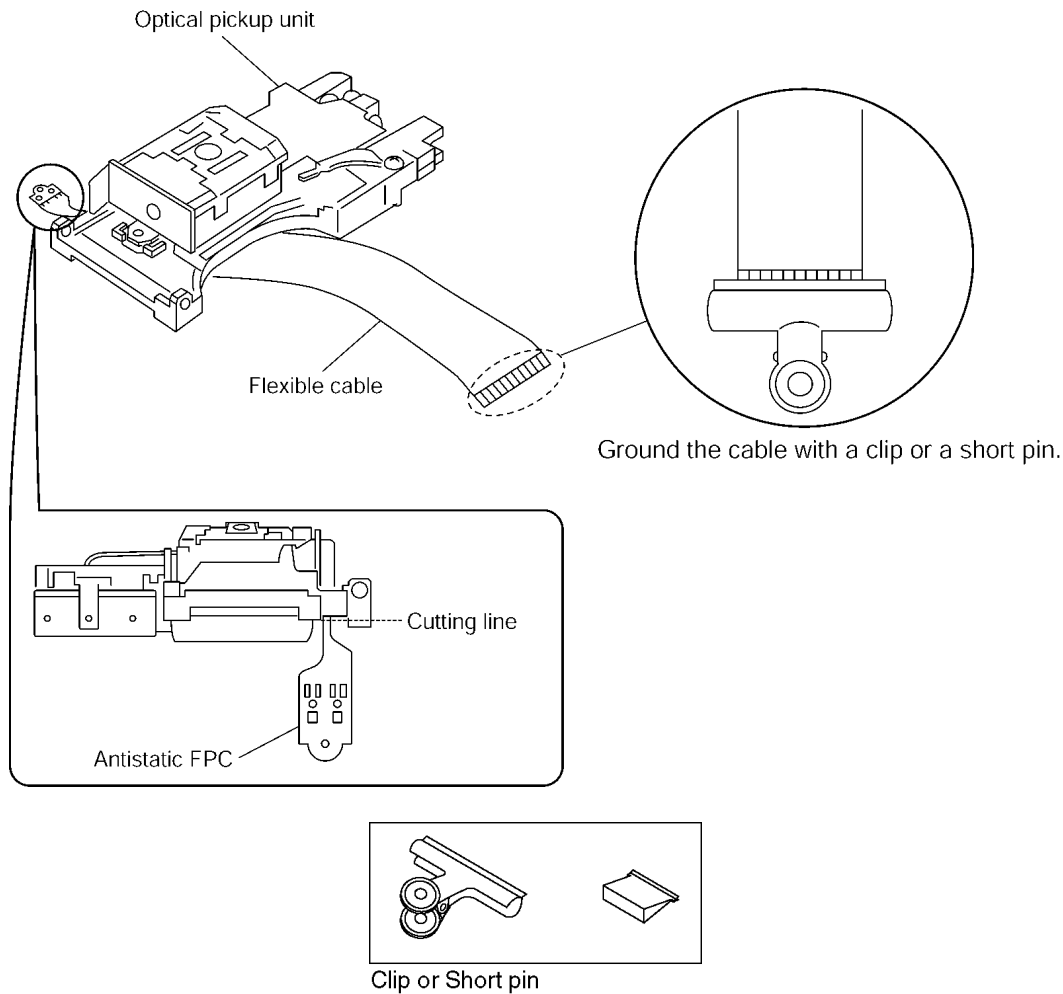

5.2. Grounding for electrostatic breakdown prevention

Some devices such as the DVD player use the optical pickup (laser diode) and the optical pickup will be damaged by static electricity in the working environment. Proceed servicing works under the working environment where grounding works is completed.

5.2.1. Worktable grounding

1. Put a conductive material (sheet) or iron sheet on the area where the optical pickup is placed, and ground the sheet.

5.2.2. Human body grounding

1. Use the anti-static wrist strap to discharge the static electricity form your body.

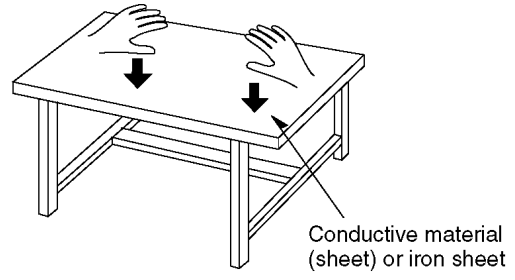
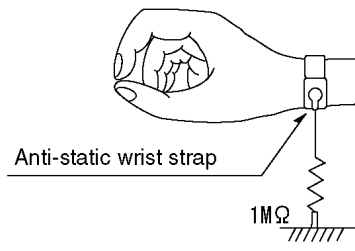

6 Accessories

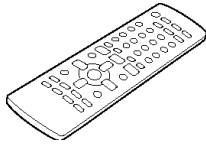

Remote control



AM loop antenna

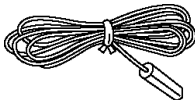

FM indoor antenna



Din adaptor
(For EB area)

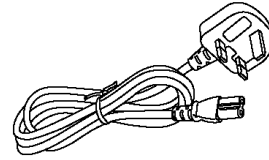

AC cord
(For EB area)

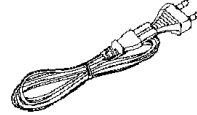

AC cord
(For E, EG areas)



Video cable
(For E, EG areas)

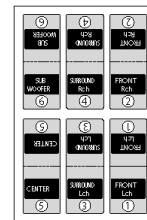

Speaker label

7 Operation Procedures

7.1. Remote Control Keys Operation

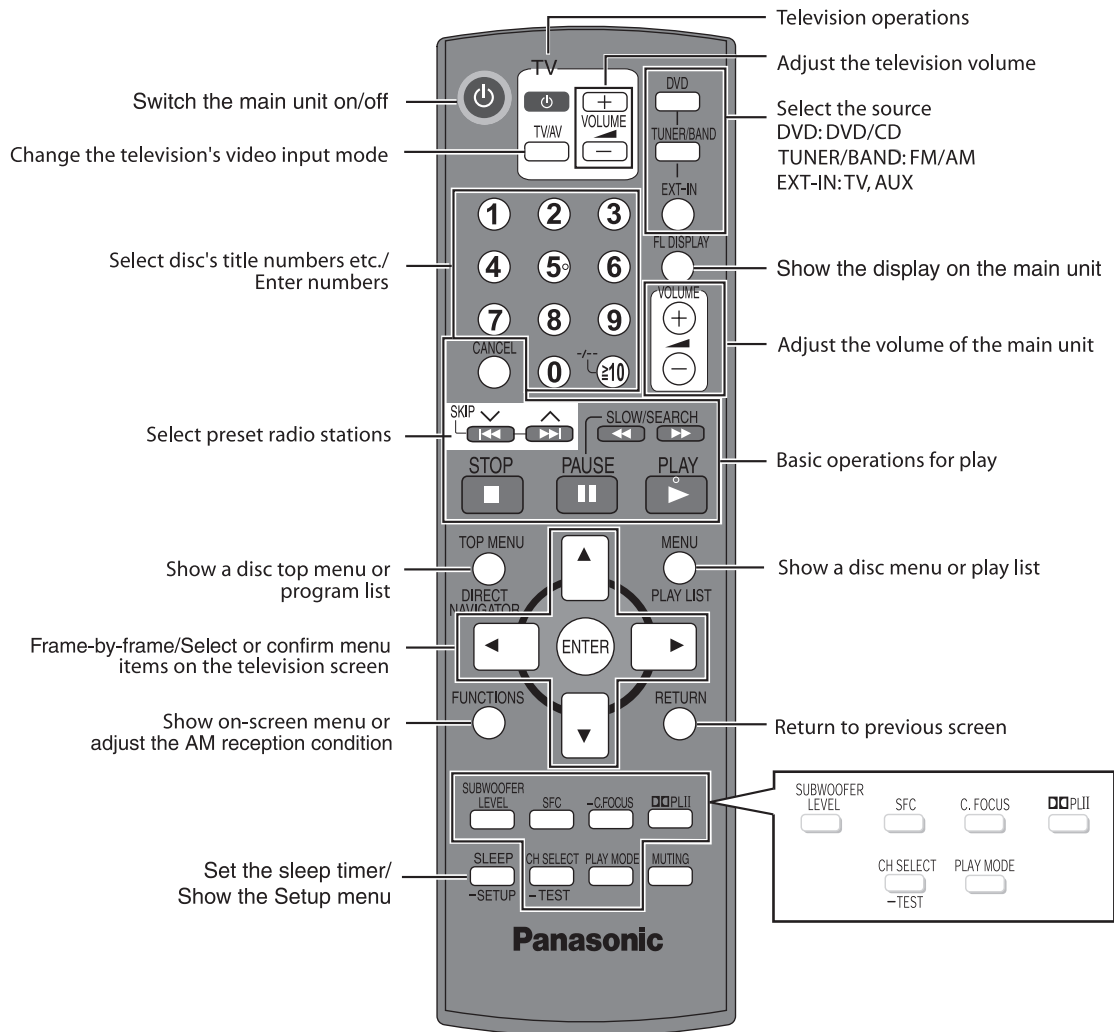

This function enables you to turn off the unit automatically after the set time.

→SLEEP 30 → SLEEP 60 → SLEEP 90
OFF ← SLEEP 120 ←

To cancel the timer
Press [SLEEP] to select "OFF".

To confirm the remaining time
Press [SLEEP] again.



To mute the sound
- Press the button to activate.
- Press again to cancel.

To cancel
- Press [MUTING] again or reduce the volume to minimum "VOL 0", and then raise it to the required level.
- Muting is cancelled when you switch the unit to standby.

7.2. Main Unit Keys Operation

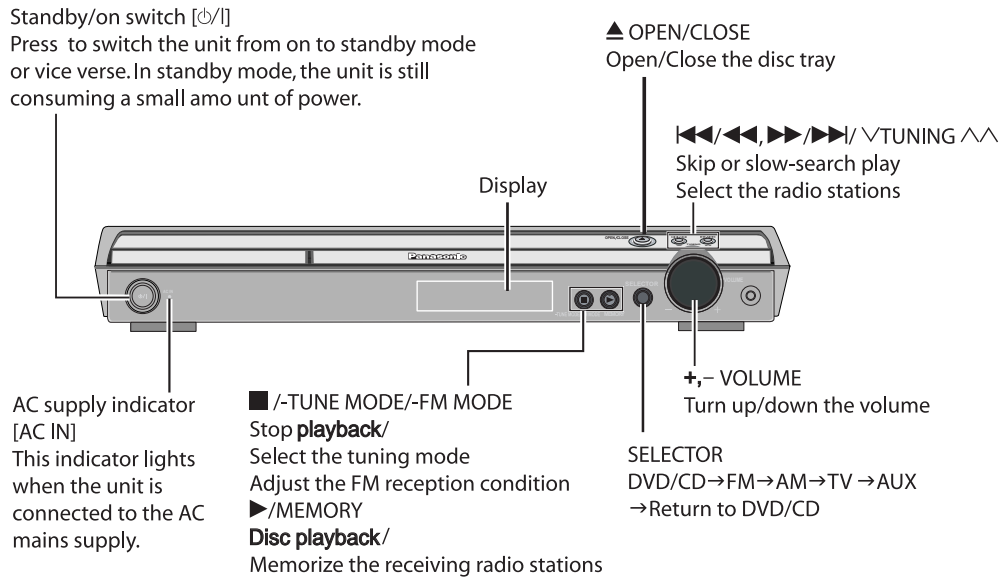

7.3. Connection Setup

7.3.1. Audio Connection for VCR/TV

For Continental Europe

This audio connection will enable you to play audio from your video cassette recorder through your home theater system.

Press [EXT-IN] to select "AUX" as the source to operate the audio input from the remote control.

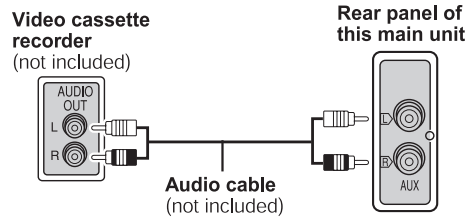

7.3.2. Scart Connection for Set Top Box/VCR/TV

For Continental Europe

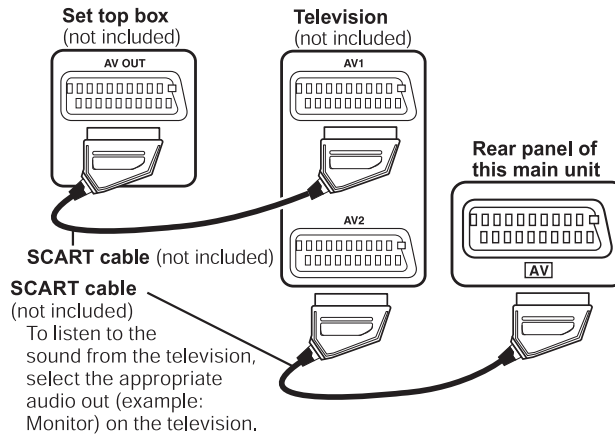

SCART cable (not included)
To listen to the sound from the television, select the appropriate audio out (example: Monitor) on the television.





Sound from the television

Press [EXT-IN] to select the "TV" audio input on the remote control.

7.4. Disc information

7.4.1. Disc playability (Media)

■ Discs that can be played

	DVD-Video DVD-V —
	Video CD VCD ● Including SVCD (Conforming to IEC62107).
	DVD-RAM DVD-VR MP3 JPEG MPEG4 DivX ^{*3,*4} ● DVD-VR Recorded with devices using Version 1.1 of the Video Recording Format (a unified video recording standard), such as DVD video recorders, DVD video cameras, personal computers, etc. ● JPEG Recorded with Panasonic SD multi cameras or DVD video recorders using the DCF (Design rule for Camera File System) Standard Version 1.0. ● MPEG4 Recorded with Panasonic SD multi cameras or DVD video recorders [conforming to SD VIDEO specifications (ASF standard)/MPEG4 (Simple Profile) video system/G.726 audio system].
	DVD-R (DVD-Video) ^{*1} / DVD-RW (DVD-Video) DVD-V ● Discs recorded and finalized ^{*2} on DVD video recorders or DVD video cameras. DVD-R (VR) ^{*1} / DVD-RW (VR) DVD-VR ● Discs recorded and finalized ^{*2} on DVD video recorders or DVD video cameras using Version 1.1 (or 1.2 DVD-R DL only) of the Video Recording Format (a unified video recording standard). DVD-R/DVD-RW MP3 JPEG MPEG4 DivX ^{*3,*4} ● Finalize ^{*2} the disc after recording.
—	+R(Video) ^{*1} / +RW(Video) DVD-V ● Discs recorded and finalized ^{*3} on DVD video recorders or DVD video cameras.
	CD CD WMA MP3 JPEG VCD MPEG4 DivX ^{*3,*4} ● This unit can play CD-R/RW recorded with the above formats. Close the sessions or finalize ^{*2} the disc after recording. ● CD This unit is compatible with HDCD, but does not support the Peak Extend function (a function which expands the dynamic range of high-level signals). HDCD-encoded CDs sound better because they are encoded with 20 bits, as compared with 16 bits for all other CDs. ● WMA MP3 JPEG This unit also plays HighMAT discs. ● WMA This unit does not support Multiple Bit Rate (MBR: a file that contains the same content encoded at several different bit rates).

*1 Includes single-sided, dual-layer discs.

*2 A process that allows play on compatible equipment.

*3 Plays all versions of DivX®6) with standard playback of DivX® media files. Certified to the DivX Home Theater Profile.

GMC (Global Motion Compensation) is not supported.

*4 Functions added with DivX Ultra are not supported.

● It may not be possible to play all the above-mentioned discs in some cases due to the type of disc or condition of the recording.

Note about using a DualDisc

- The digital audio content side of a DualDisc does not meet the technical specifications of the Compact Disc Digital Audio (CD-DA) format so playback may not be possible.
- Do not use DualDisc in this unit as it may not be possible to insert it correctly and it may get scratched or scraped.

■ Discs that cannot be played

DVD-RW version 1.0, DVD-Audio, DVD-ROM, CD-ROM, CDV, CD-G, SACD, Photo CD, DVD-RAM that cannot be removed from their cartridge, 2.6-GB and 5.2-GB DVD-RAM, and "Chaaji VCD" available on the market including CVD, DVCD and SVCD that do not conform to IEC62107.

■ Video systems

- This unit can play PAL and NTSC, but your television must match the system used on the disc.
- PAL discs cannot be correctly viewed on an NTSC television.
- This unit can convert NTSC signals to PAL 60 for viewing on a PAL television.

■ Disc handling precautions

- Do not attach labels or stickers to discs. This may cause disc warping, rendering it unusable.
- Do not write on the label side with a ball-point pen or other writing instrument.
- Do not use record cleaning sprays, benzine, thinner, liquids which prevent static electricity, or any other solvent.
- Do not use scratch-proof protectors or covers.
- Do not use the following discs:
 - Discs with exposed adhesive from removed stickers or labels (rented discs, etc).
 - Discs that are badly warped or cracked.
 - Irregularly shaped discs, such as heart shapes.

■ To clean discs

Wipe with a damp cloth and then wipe dry.

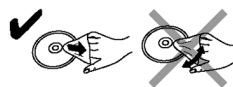

7.4.2. File Extension Type Support (WMA/MP3/JPEG/MPEG4/DivX)

Tips for making data discs

When there are more than eight groups, the eighth group onwards will be displayed on one vertical line in the menu screen.

There may be differences in the display order on the menu screen and computer screen.

This unit cannot play files recorded using packet write.

DVD-RAM

Discs must conform to UDF 2.0.

DVD-R/RW

Discs must conform to UDF bridge (UDF 1.02/ISO9660).

This unit does not support multi-session. Only the default session is played.

CD-R/RW

Discs must conform to ISO9660 level 1 or 2 (except for extended formats).

This unit supports multi-session but if there are many sessions it takes more time for play to start. Keep the number of sessions to a minimum to avoid this.

Naming folders and files

Files are treated as contents and folders are treated as groups on this unit.

At the time of recording, prefix folder and file names. This should be with numbers that have an equal number of digits, and should be done in the order you want to play them (this may not work at times). Files must have the extension (➡ see below).

WMA (Extension: ".WMA" or ".wma")

Compatible compression rate: between 48 kbps and 320 kbps.

You cannot play WMA files that are copy protected.

This unit does not support Multiple Bit Rate (MBR).

MP3 (Extension: ".MP3" or ".mp3")

Compatible compression rate: between 32 kbps and 320 kbps.

This unit does not support ID3 tags.

Compatible sampling rates:

– DVD-RAM, DVD-R/RW: 11.02, 12, 22.05, 24, 44.1 and 48 kHz

– CD-R/RW: 8, 11.02, 12, 16, 22.05, 24, 32, 44.1 and 48 kHz

JPEG (Extension: ".JPG", ".jpg", ".JPEG" or ".jpeg")

JPEG files taken on a digital camera that conform to DCF Standard (Design rule for Camera File system) Version 1.0 are displayed. Files that have been altered, edited or saved with computer picture editing software may not be displayed.

This unit cannot display moving pictures, MOTION JPEG and other such formats, and still pictures other than JPEG (Example: TIFF), or play pictures with attached audio.

MPEG4 (Extension: ".ASF" or ".asf")

You can play MPEG4 data [conforming to SD VIDEO specifications (ASF standard)/MPEG4 (Simple Profile) video system/G.726 audio system] recorded with Panasonic SD multi cameras or DVD video recorders with this unit.

The recording date may differ from that of the actual date.

DivX (Extension: ".DIVX", ".divx", ".AVI" or ".avi")

You can play all versions of DivX® video (including DivX®6) [DivX video system/MP3, Dolby Digital or MPEG audio system] with standard playback of DivX® media files. Functions added with DivX Ultra are not supported.

GMC (Global Motion Compensation) is not supported.

DivX files greater than 2 GB or have no index may not be played properly on this unit.

This unit supports all resolutions up to maximum of 720 x 480 (NTSC)/720 x 576 (PAL).

You can select up to eight types of audio and subtitles on this unit.

Example: **MP3**

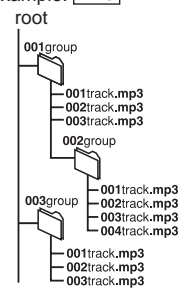

7.5. About DivX VOD Content

About DivX VOD content

DivX Video-on-Demand (VOD) content is encrypted for copyright protection. In order to play DivX VOD content on this unit, you first need to register the unit.

Follow the online instructions for purchasing DivX VOD content to enter the unit's registration code and register the unit. For more information about DivX VOD, visit www.divx.com/vod.

Display the unit's registration code

(⇒ Refer to OI page 23, "DivX Registration" in "Others" tab)

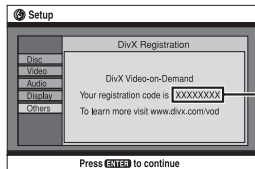

8 alphanumeric characters

We recommend that you make a note of this code for future reference.

After playing DivX VOD content for the first time, another registration code is then displayed in "DivX Registration". Do not use this registration code to purchase DivX VOD content. If you use this code to purchase DivX VOD content, and then play the content on this unit, you will no longer be able to play any content that you purchased using the previous code.

If you purchase DivX VOD content using a registration code different from this unit's code, you will not be able to play this content. ("Authorization Error" is displayed.)

Regarding DivX content that can only be played a set number of times

Some DivX VOD content can only be played a set number of times. When you play this content, the remaining number of plays is displayed. You cannot play this content when the number of remaining plays is zero. ("Rented Movie Expired" or "Rental Expired" is displayed.)

When playing this content

The number of remaining plays is reduced by one if

- you press [⏪] or press and hold [–SETUP].
- you press [■, STOP]. (Press [⏸, PAUSE] to pause play.)
- you press [⏮, ⏭] (skip) or [⏪, ⏩] (slow/search) etc. and arrive at another content or the start of the content being played.

Resume (⇒ OI page 15, Stop) and Marker (⇒ OI page 20, Play Menu) functions do not work.

8 Self-Diagnosis and special mode setting

8.1. Service Mode Summary Table

The service modes can be activated by pressing various button combination on the player and remote control unit.

Below is the summary of major checking:







Player buttons	Remote control unit buttons	Application	Note
STOP	0	Error code display	(Refer to the section, "8.3 DVD Self Diagnostic Function-Error Code").
	5	Jitter checking	
	6	Region display and mode	
	7	Micro-processor firmware version check	
	8	DVD module firmware version check.	
	≥ 10	Initialization of the player (factory setting is restored.) Used after replacement of micro-computer, FLASH ROM IC, EEPROM and HDMI module.	(Refer to the section "8.2 Service Mode Table 1" for more information).
	ENTER	DVD module reset (During initialisation)	
	FUNCTIONS	DVD laser drive current check	
	3	CD laser drive current check	
	PAUSE	Writing of laser drive current value after replacement of optical pickup (Do use this function only when optical pickup is replaced.)	
			(Refer to the item "8.2.1. Optical Pick-up Self-Diagnosis").



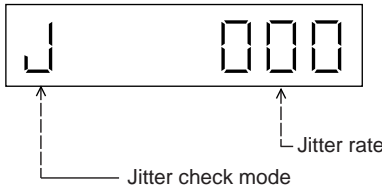

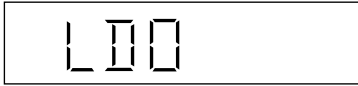
8.2. Service Mode Table 1

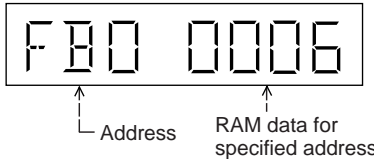

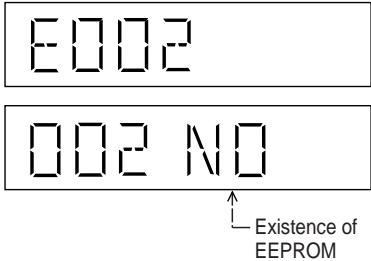

By pressing various button combinations on the player and remote control unit can activate the various service modes for checking.

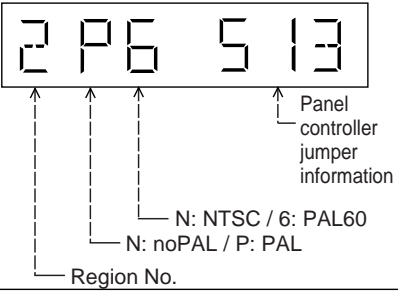
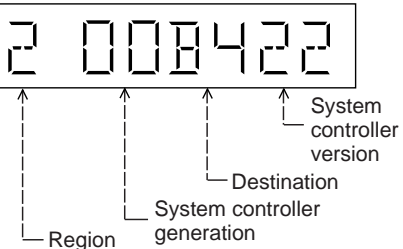
Special Note:

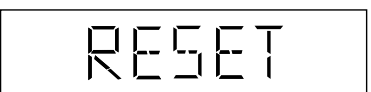
Due to the limitations of the no. characters that can be shown on FL Display, the "FL Display" button on the remote control unit is used to show the following page. (Display 1/Display 2).

Item		FL Display	Key Operation
Mode Name	Description		Front Key
Jitter check	Jitter check Jitter rate is measured and displayed. Measurement is repeatedly done in the cycle of one second. Read error counter starts from zero upon mode setting. When target block data failed to be read out, the counter advances by one increment. When the failure is caused by minor error, it may be corrected when retried to enable successful reading. In this case, the counter advances by one. When the error persists even after retry, the counter may jump by two or more.	 <p>Jitter rate is shown in decimal notation to one place of decimal. Focus drive value is shown in hexadecimal notation.</p>	In STOP (no disc) mode, press STOP button on the player, and "5" button on the remote control unit. Press STOP or OPEN button to exit. Press "FL Display" on remote control unit for next page (FL Display).
Error code check	Error code check The latest error code stored in the EEPROM IC is displayed.	 <p>Error code (play_err) is expressed in the following convention. Error code = 0 x DAXX is expressed: DVDnn UXX Error code = 0 x DBXX is expressed: → DVDnn HXX Error code = 0 x DXXX is expressed: → DVDnn FXXX Error code = 0 x 0000 is expressed: → DVDnn F--- * "xx" denotes the error code →</p>	In STOP (no disc) mode, press STOP button on the player, and "0" button on the remote control unit. * With pointing of cursor up and down on display. Cancelled automatically 5 seconds later. To exit, press [POWER] button on main unit or remote control.
Initial setting of laser drive current	Initial setting of laser drive current. Initial current value for each of DVD laser and CD laser is separately saved in the EEPROM IC.	 <p>The value denotes the current in decimal notation. The above example shows the initial current is 34mA and 28mA for DVD laser and CD laser respectively when the laser is switched on.</p>	In STOP (no disc) mode, press STOP button on the player, and PAUSE button on the remote control unit. Cancelled automatically 5 seconds later. Press "FL Display" on remote control unit for next page (FL Display) on values of laser drive current.
DVD laser drive current measurement	DVD laser drive current measurement ·DVD laser drive current is measured and the result is displayed together with the initial value stored in the EEPROM IC. After the measurement, DVD laser emission is kept on. It is turned off when POWER key is switched off. (It is also turned off when POWER button on the player is switched off.)	 <p>The value denotes the current in decimal notation. The above example shows the initial current is 34mA and the measured value is 32mA.</p>	In STOP (no disc) mode, press STOP button on the player, and FUNCTIONS button on the remote control unit. Cancelled automatically 5 seconds later. Press "FL Display" on remote control unit for next page (FL Display) on values of dvd drive current.
ADSC internal RAM data check	ADSC internal RAM data check ·ADSC internal RAM data is read out and displayed.	 <p>The value is shown in hexadecimal notation. The above example shows the data in ADSC address OFAh is 6901h.</p>	In STOP (no disc) mode, press STOP button on the player, and "1" button on the remote control unit. Press STOP or PLAY button.
CD laser drive current measurement	CD laser drive current measurement CD laser drive current is measured and the result is displayed together with the initial value stored in the EEPROM IC. After the measurement, CD laser emission is kept on. It is turned off when POWER key is switched off. (It is also turned off when POWER button on the player is switched off.)	 <p>The value denotes the current in decimal notation. The above example shows the initial current is 28mA and the measured value is 26mA.</p>	In STOP (no disc) mode, press STOP button on the player, and "3" button on the remote control unit. Cancelled automatically 5 seconds later. Press "FL Display" on remote control unit for next page. (FL Display)

Item		FL Display	Key Operation
Mode Name	Description		Front Key
Micro-processor firmware version display & EEPROM checksum display.	Micro-processor firmware version display & EEPROM checksum display. EEPROM checksum is only available due to existence of EEPROM IC. (NO: NO EEPROM IC) If EEPROM IC is present, the checksum value will be displayed. It displays as "NG" if the EEPROM IC installed is not working properly.		In STOP (no disc) mode, press STOP button on the player, and "7" button on the remote control unit. Cancelled automatically 5 seconds later. Press "FL Display" button on remote control unit for next page. (FL Display)
Initialization	Initialization User settings are cancelled and player is initialized to factory setting.		In STOP (no disc) mode, press STOP button on the player, and ≥ 10 button on the remote control unit. Cancelled automatically 5 seconds later.
Region display	Region display & mode		In STOP (no disc) mode, press STOP button on the player, and "6" button on the remote control unit. Cancelled automatically 5 seconds later.
DVD module firmware version display	DVD module firmware version is displayed on the FL Display. The firmware version can be updated using recovery disc.		In STOP (no disc) mode, press STOP button on the player, and "8" button on the remote control unit. Cancelled automatically 5 seconds later.
Communication error display	Displays frequency of communication errors between system control IC and mechanism control IC during DVD module.		In STOP (no disc) mode, press STOP button on the player, and "MENU" button on the remote control unit. Cancelled automatically 5 seconds later.
DVD Module Reset	To reset DVD Module. This process is used when the DVD module or flash ROM IC is replaced with a new one.		While in initialization mode, press & hold STOP button on player, follow by "ENTER" button on the remote control unit. Cancelled automatically 5 seconds later.

Item		FL Display	Key Operation
Mode Name	Description		Front Key
Timer 1 check	<p>Timer 1 check Laser operation timer is measured separately for DVD laser and CD laser.</p> <p>Press "FL Display" button for next page of FL Display</p>	 <p>Shown to the left is DVD laser time, and to the right is CD laser time. Time is shown in 4 digits of decimal notation in a unit of 10 hours. "0000" will follow "9999".</p>	<p>In STOP (no disc) mode, press STOP button on the player, and "▲" button on the remote control unit. Cancelled automatically 5 seconds later.</p>
Timer 1 reset	<p>Timer 1 reset Laser operation timer of both DVD laser and CD laser is reset all at once.</p>	 <p>Shown to the left is DVD laser time, and to the right is CD laser time. It will clear to "0000" upon reset.</p>	<p>While displaying Timer 1 data, press STOP button on the player, and "▼" button on the remote control unit. Cancelled automatically 5 seconds later.</p>
Timer 2 check	<p>Timer 2 check Spindle motor operation timer Press "FL Display" button for next page of FL Display</p>	 <p>Time is shown in 5 digits of decimal notation in a unit of 10 hours. "00000" will follow "99999".</p>	<p>In STOP (no disc) mode, press STOP button on the player, and "▶" button on the remote control unit. Cancelled automatically 5 seconds later.</p>
Timer 2 reset	<p>Timer 2 reset Spindle motor operation timer Press "FL Display" button for next page of FL Display</p>	 <p>Time is shown in 5 digits of decimal notation in a unit of 10 hours. It will be cleared to "00000" upon activating this.</p>	<p>While displaying Timer 2 data, press STOP button on the player, and "◀" button on the remote control unit. Cancelled automatically 5 seconds later.</p>

8.2.1. Optical Pick-up Self-Diagnosis







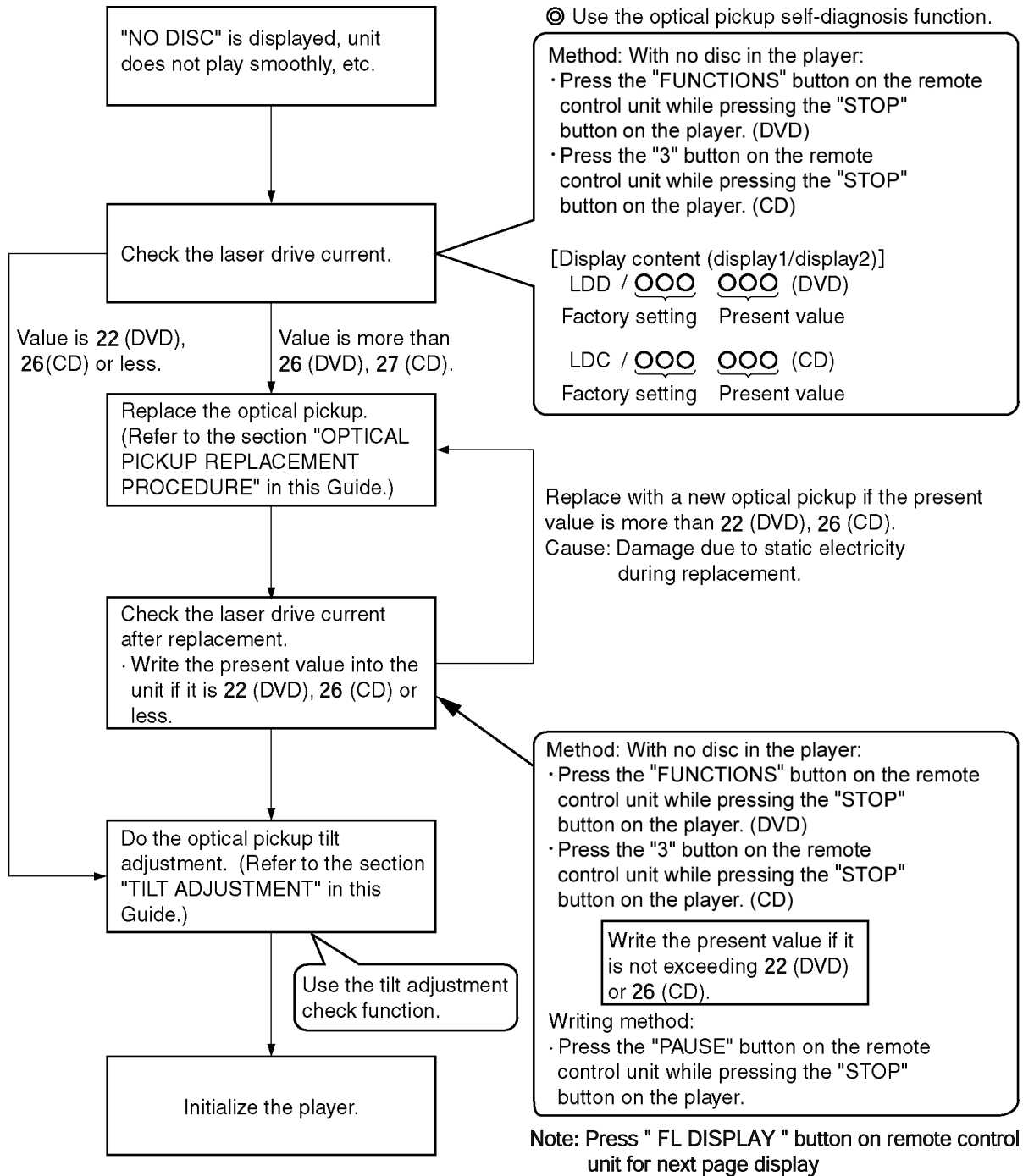

The optical pickup self-diagnosis function and tilt adjustment check function have been included in this unit. When repairing, use the following procedure for effective self-diagnosis and tilt adjustment. Be sure to use the self-diagnosis function before replacing the optical pickup when "NO DISC" is displayed. As a guideline, you should replace the optical pickup when the value of the laser drive current is more than 55.

Note:

Press the power button to turn on the power, and check the value within three minutes before the unit warms up. (Otherwise, the result will be incorrect.)

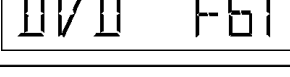
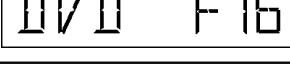
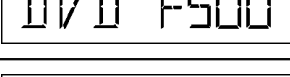
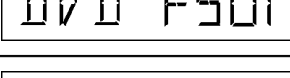
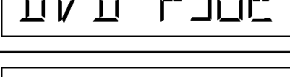
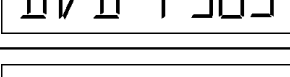
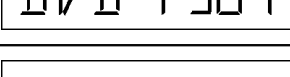
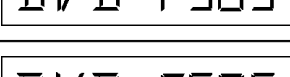
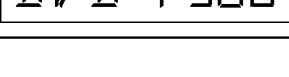

8.3. DVD Self Diagnostic Function-Error Code

Error Code	Diagnosis Contents	Description of error	Automatic FL Display	Remarks
U11	Focus servo error	Focus coil NG (OPU unit abnormal)		Press [n STOP] on main unit for next error.
H01	Tray loading error / abnormality	The tray is not able to open		Press [n STOP] on main unit for next error
H02	Spindle servo error, DSC disc motor error	(Spindle servo, DSC (IC8251) Spindle motor, CLV servo error)		Press [n STOP] on main unit for next error
H03	Traverse motor error	(Traverse motor, IC8251)		Press [n STOP] on main unit for next error
H04	Tracking servo error	Tracking coil NG (OPU unit abnormal)		Press [n STOP] on main unit for next error
H05	Seek timeout error	Timeout of unit when seeking time is reached		Press [n STOP] on main unit for next error
H15	Disc tray open detection switch (S9001) failure	The disc tray cannot be opened: it closes spontaneously		Press [n STOP] on main unit for next error
H16	Disc tray close detection switch (S9001) failure	The disc tray cannot be closed: it opens spontaneously		Press [n STOP] on main unit for next error
F61	Power digital amp IC op & DC output voltage abnormal.	Upon power-on PCONT=High, DCDET=Low		Press [n STOP] on main unit for next error
F76	Power digital amp IC op & DC output voltage abnormal.	Speaker Jack shorted or amp circuit		Press [n STOP] on main unit for next error
F500	DSC error	DSC (IC8251) stops in the occurrence of servo error (startup, focus error, etc.)		Press [n STOP] on main unit for next error
F501	DSC not Ready error	DSC-system computer communication error (Communication failure caused by idling of DSC)		Press [n STOP] on main unit for next error
F502	DSC Time out error	Similar as F500		Press [n STOP] on main unit for next error
F503	DSC communication Failure	Communication error (result error occurred although communication command was sent)		Press [n STOP] on main unit for next error
F504	Abnormal adjusting DSC data slice offset			Press [n STOP] on main unit for next error
F505	DSC Attention error	Similar as F500		Press [n STOP] on main unit for next error
F506	Invalid media	Disc is flipped over, TOC unreadable, incompatible disc media		Press [n STOP] on main unit for next error

Error Code	Diagnosis Contents	Description of error	Automatic FL Display	Remarks
F600	Access failure to management information caused by demodulation error	Operation stopped because navigation data is not accessible caused by the demodulation defect	DVD F600	Press [n STOP] on main unit for next error
F601	Indeterminate sector ID requested	Operation stopped caused by the request to access abnormal ID data	DVD F601	Press [n STOP] on main unit for next error
F602	Access failure to LEAD-IN caused by demodulation error	LEAD IN data unreadable	DVD F602	Press [n STOP] on main unit for next error
F603	Access failure to KEYDET caused by demodulation error	Access failure to CSS data of disc	DVD F603	Press [n STOP] on main unit for next error
F610	ODC abnormality	No permission for command execution	DVD F610	Press [n STOP] on main unit for next error
F611	No CRC OK for a specific time (CD)	Access failure to seek address in CD series	DVD F611	Press [n STOP] on main unit for next error
F612	No CRC OK for a specific time (DVD)	Access failure to ID data in DVD series	DVD F612	Press [n STOP] on main unit for next error
F620	Laser safeguard: high temperature condition	High temperature of the laser guide unit (OPU unit)	DVD F620	Press [n STOP] on main unit for next error
F621	Laser safeguard: circuit failure condition	Circuitry failure of the laser guide unit (OPU unit)	DVD F621	Press [n STOP] on main unit for next error
F103	Illegal highlight Position	Big possibility of disc specification violation during highlight display	DVD F103	Press [n STOP] on main unit for next error
F4FF	Force initialize failure (time out)	Timeout when force initialization fails	DVD F4FF	Press [n STOP] on main unit for next error
F700	MBX overflow	When replying message to disc manager	DVD F700	Press [n STOP] on main unit for next error
F701	Message command does not end	Next message is sent before replying to disc manager	DVD F701	Press [n STOP] on main unit for next error
F702	Message command changes	Message is changed before it is sent as a reply to disc manager	DVD F702	Press [n STOP] on main unit for next error
F880	Task number is not appropriate	Message coming from a non-existing task	DVD F880	Press [n STOP] on main unit for next error
F890	Sending message when message is being sent to AV task	Sending message to AV task	DVD F890	Press [n STOP] on main unit for next error
F891	Message couldn't be sent to AV task	Begin sending message to AV task	DVD F891	Press [n STOP] on main unit for next error

Error Code	Diagnosis Contents	Description of error	Automatic FL Display	Remarks
F893	FLASH ROM IC problem	FLASH ROM IC installed is not operating properly (Necessary replacement of FLASH ROM IC) or firmware problem	DVD F893	Press [n STOP] on main unit for next error
F894	EEPROM abnormality	EEPROM IC installed is not operating in normal condition (EEPROM contains necessary data)	DVD F894	Press [n STOP] on main unit for next error
F895	Region setting abnormality	Firm version agreement check for factory preset setting failure prevention. Check region setting & re-initialize	DVD F895	Press [n STOP] on main unit for next error
F896	No existence model	Firm version agreement check for factory preset setting failure prevention	DVD F896	Press [n STOP] on main unit for next error
F897	Initialize is not completed	Initialize completion check for factory preset setting failure prevention	DVD F897	Press [n STOP] on main unit for next error
F898	Disagreement of hardware and software	Unsuitable combination of AV DECODER, SDRAM and FLASH ROM (firmware)	DVD F898	Press [n STOP] on main unit for next error
F8A0	Message command is not appropriate	Begin sending message to AV task	DVD F8A0	Press [n STOP] on main unit for next error

Note:

An error code will be canceled if a power supply is turned OFF.

*1: CPPM is the copy guard function beforehand written in the disk for protection of copyrights.

*2: CEC is the consumer electronic control used for high-level user control of HDMI-connected devices.

*3: HDCP is the specification developed to control digital audio & video contents transmission for DVI or HDMI connections.

8.4. Sales Demonstration Lock Function

This function prevents discs from being lost when the unit is used for sales demonstrations by disabling the disc eject function. "LOCKED" is displayed on the unit, and ordinary operation is disabled.

8.4.1. Setting

· Prohibiting removal of disc

1. Select the DVD/CD function.
2. Press and hold down the  button and the power button on the player for at least three seconds. (The message, "___LOCKED_" appears when the function is activated.)

Note:











OPEN/CLOSE , DISC CHECK and DISC CHANGE buttons are invalid and the player displays "___LOCKED_" while the lock function mode is entered.

· Prohibiting operation of selector and disk

1. Select the DVD/CD function.
2. Press and hold down the  button and the power button on the player for at least three seconds. (The message, "___LOCKED_" appears when the function is activated.)

Note:

The following buttons are invalid and the player displays "___LOCKED_" while the lock function mode is entered.

Player	 ,  ,  , SELECTOR,  ,  , VOLUME KNOB, DISC CHECK, DISC CHANGE, DISC1-DISC5
Remote controller unit	SLEEP, REPEAT, 0~9, ≥ 10 , RETURN, TOP MENU,  ,  ,  ,  ,  ,  , POSITION MEMORY, TUNER/BAND, D.MIX, CH SELECT/ TEST, SET UP/ MUTING, DISPLAY, GROUP, TV, VCR/AUX, QUICK REPLAY, SUBTITLE, FL DISPLAY, CH & VOLUME

8.4.2. Cancellation

The lock can be cancelled by the same procedure as used in setting. ("UNLOCK" is displayed on cancellation. Disconnecting the

power cable from power outlet does not cancel the lock.)

8.5. Service Precautions

8.5.1. Recovery after the DVD player is repaired

- When the IC or HDMI module P.C.B. is replaced, carry out the recovery processing to optimize the drive. Playback the recovery disk to process the recovery automatically.
- Recovery disc (Product number: RFKZD03R005)
- Performing recovery process
 1. Load the recovery disc RFKZD03R005 [SPC] on to the player and run it.
 2. Recovery is performed automatically. When it is finished, a message appears on the screen.
 3. Remove the recovery disc.
 4. Turn off the power.
 5. Initialize the player.

8.5.2. Firmware version-up of the DVD player

- The firmware of the DVD player may be renewed to improve the quality including operability and playability to the substandard discs.processing to optimize the drive.
The recovery disc has also firmware version-up.
- After version-up, recovery processing is executed automatically.
- Part number of the recovery disc for version-up will be noticed when it is supplied.
- Updating firmware
 1. Load the recovery disc on to the player and run it.
 2. Firmware version of the player is automatically checked. Appropriate message appears whenever necessary.
 3. Using remote controller's cursor key, select whether version updating is to be done or not. (Selection of Yes/No)
 4. a. If Yes is selected, version updating is performed.
 - b. If No is selected, only recovery is performed.
 5. a. When updating is finished, remove the disc according to the message appearing on the screen.
 - b. Remove the disc according to the message appearing on the screen.
 6. Turn off the power.

Note:

If the AC power supply is shut out during version-up due to a power failure, the version-up is improperly carried out. In such a case, replace the FLASH ROM IC and carry out the version-up again.

8.5.3. DVD Module Reset

- When after replacing Flash Rom IC or the DVD Module P.C.B., FL displays error code "DVD F897". This means the unit is not initialized properly and the following process needs to be carry out.
- Procedures:
 1. Press ≥ 10 on remote control while pressing "STOP" button on main unit. (To enter into initialization mode)
 2. FL display show "INIT" on main unit.
 3. While still pressing "STOP" button on main unit, press "ENTER" on remote control. (In initialization mode)
 4. FL will display "RESET" before FL display will change to TOC reading again.
 5. Power off unit. Unplug the AC cord.
 6. Power on the unit. It should be no problem. If problem persist check on the DVD module P.C.B. or FLASH ROM IC.

9 Assembling and Disassembling

“ATTENTION SERVICER”

Be careful when disassembling and servicing.

Some chassis components may have sharp edges.

Special Note:

1. **This section describes the disassembly procedures for all the major printed circuit boards and main components.**
2. **Before the disassembly process was carried out, do take special note that all safety precautions are to be carried out. (Ensure that no AC power supply is connected during disassembling.)**
3. **For assembly after operation checks or replacement, reverse the respective procedures. Special reassembly procedures are described only when required.**
4. **The Switch Regulator IC may have high temperature after prolonged use. Use caution when removing the top cabinet and avoid touching heat sinks located in the unit.**
5. **Select items from the following index when checks or replacement are required.**
 - Disassembly of Top Cabinet
 - Disassembly of DVD Lid (When taking out disc manually)
 - Disassembly of Front Panel
 - Disassembly of FL P.C.B. & Volume P.C.B.
 - Disassembly of Mechanism Unit
 - Disassembly of DVD Module P.C.B.
 - Disassembly of Rear panel
 - Disassembly of SMPS Module P.C.B.
 - Disassembly of Main P.C.B. & Tuner Extent P.C.B.
 - Disassembly of Digital Amp IC

CAUTION NOTE:

Please use original screw and at correct locations.

SMPS Module P.C.B. (SMPS) Replacement

1. **This model uses SMPS Module to provide the necessary supply voltages for the unit.**
2. **It is advisable to replace the SMPS Module once upon detecting of non-working conditions. Do not attempt to repair or replace it by components.**
3. **Non-working conditions include:**
 - I**With AC supply but no supply voltages after checking at CN2 and/or CN3 respectively.
 - I**Broken fuse. (Substitute compatible part for fuse: K5D312BNA005)
 - I**Wire connection problem.
 - I**Non-working parts in SMPS Module P.C.B. (Check components)

9.1. Disassembly Flow Chart

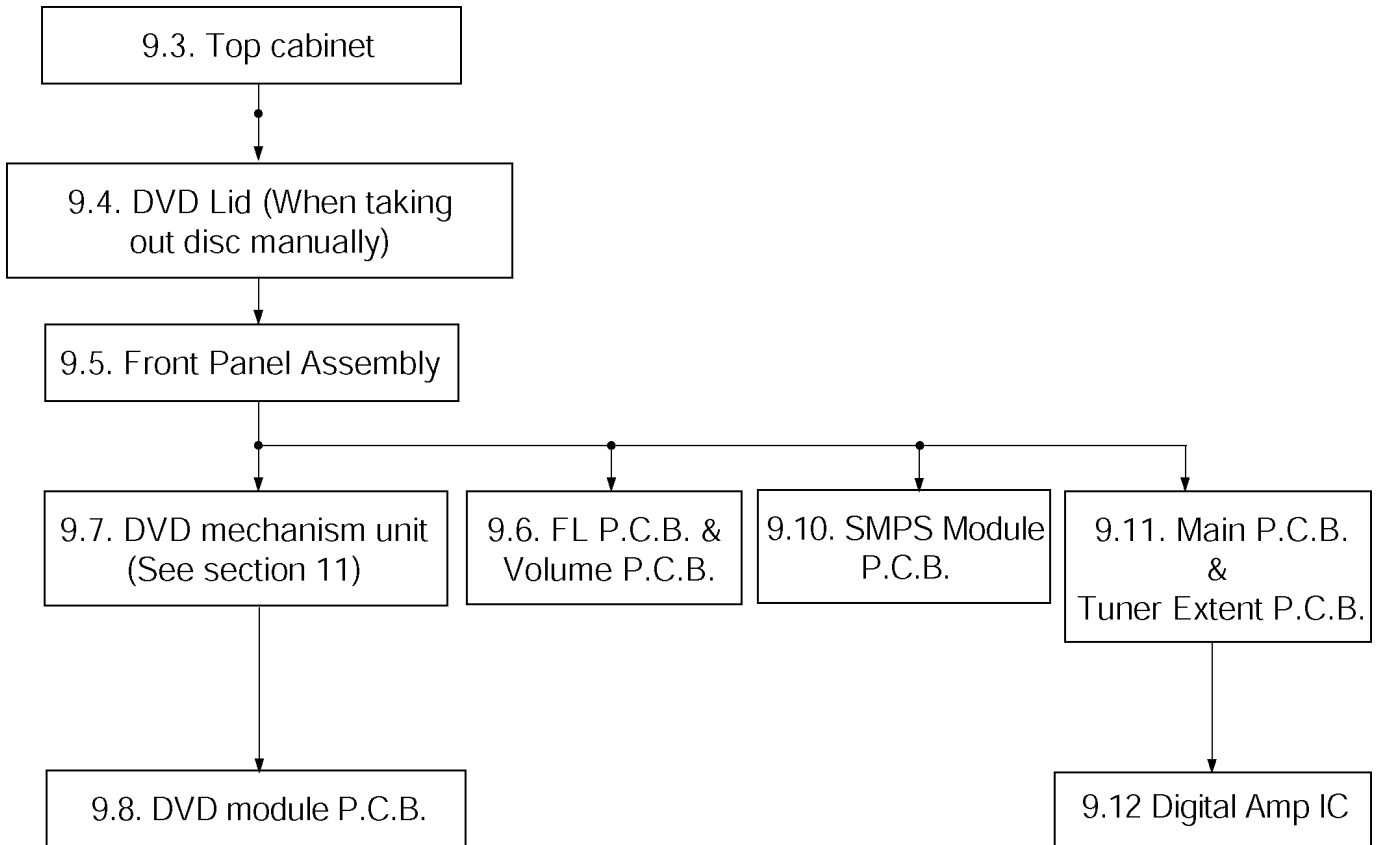

9.2. Main Components and P.C.B. Locations

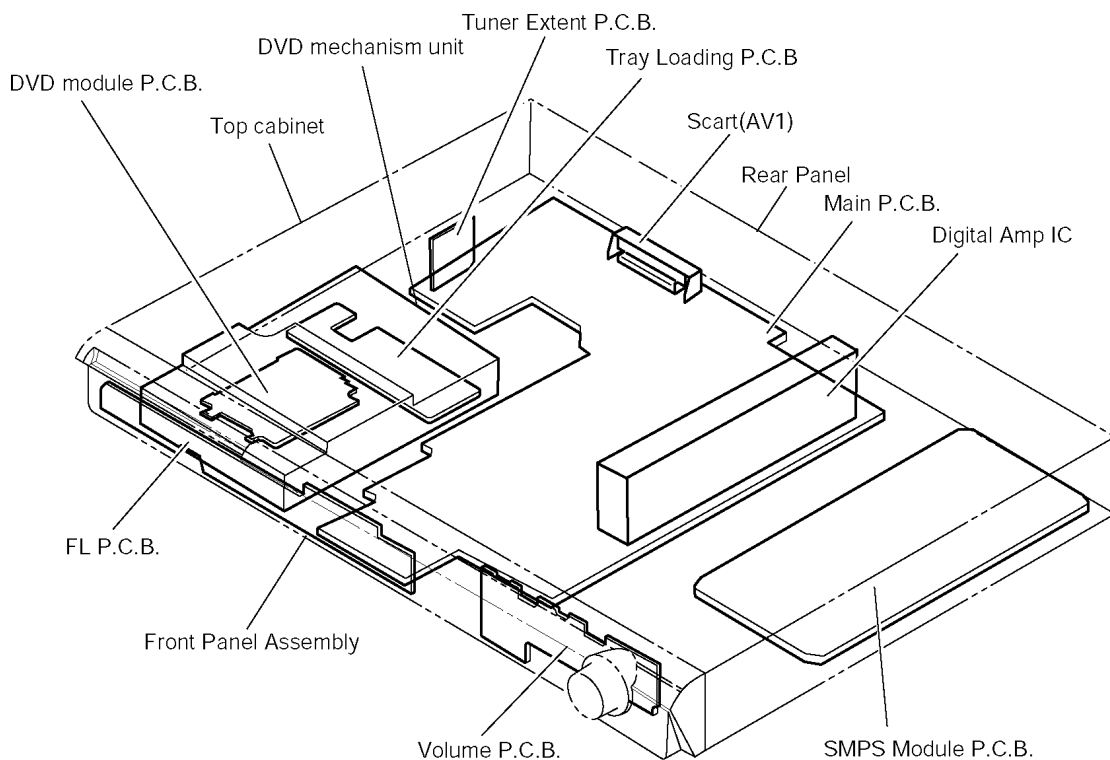

9.3. Disassembly of Top Cabinet

Step 1 Remove 4 screws.

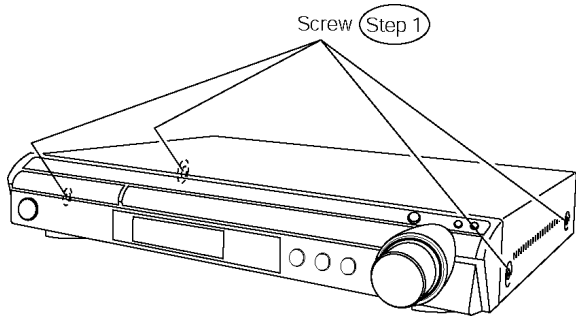

Step 2 Remove 3 screws. (Rear view)

Step 3 Lift up and remove the top cabinet.

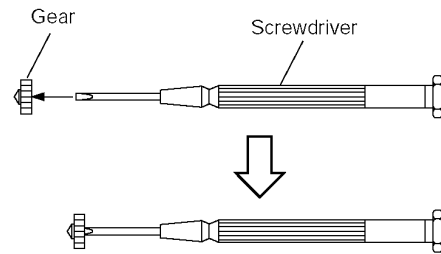
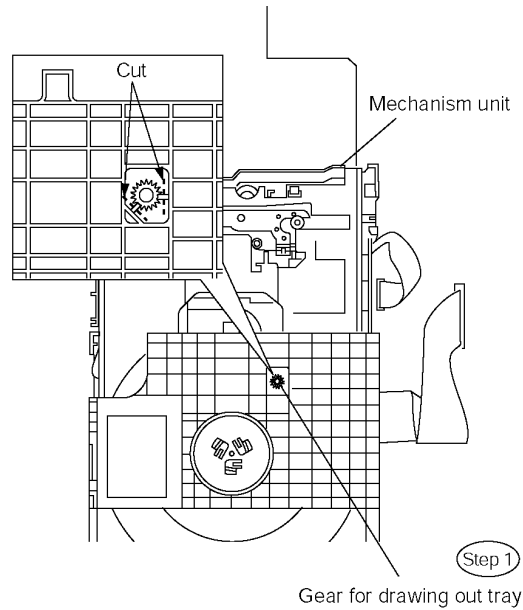
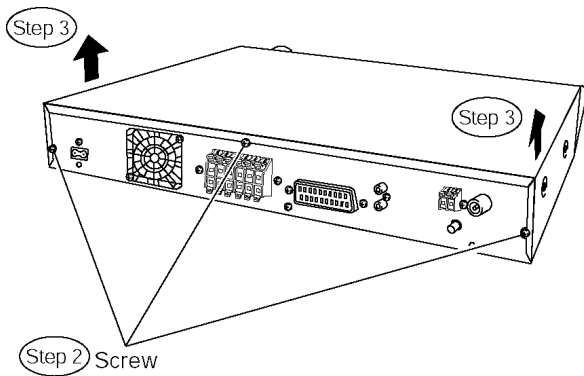

< Gear jig >

9.4. Disassembly of the DVD Lid (When taking out disc manually)

Step 1 Detach the gear for drawing out tray from the mechanism unit. Inserts a screw driver into the gear. (The gear jig)

Step 2 Insert the gear jig into the tray open/ close hole.

Step 3 Turn the gear jig counterclockwise to open the tray.

Note : Do not use force to push the tray backwards as it can damage the mechanism unit.

Step 4 Turn the gear jig clockwise to return tray.

Step 5 Remove the tabs and remove DVD lid.

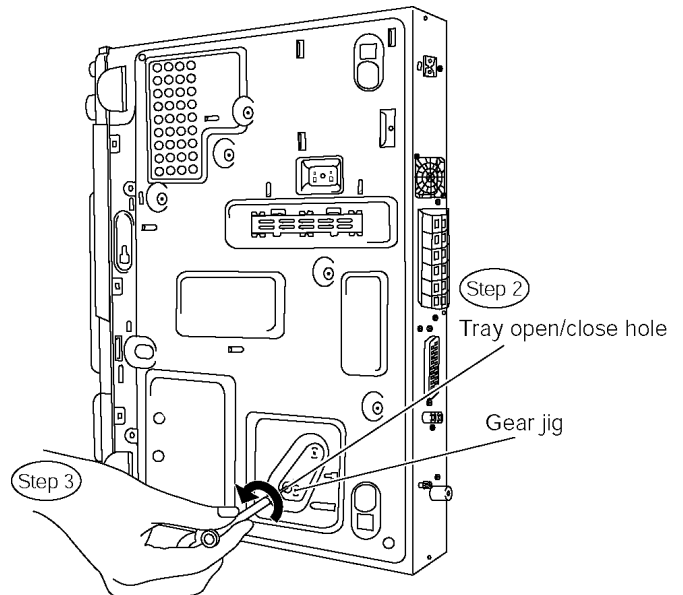

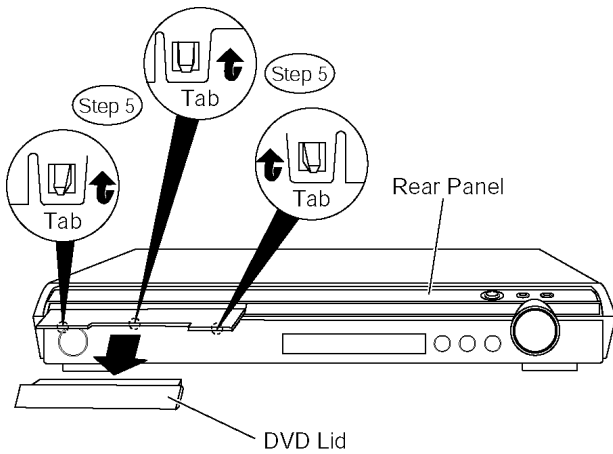

9.5. Disassembly of Front Panel Assembly

· Follow (Step 1) to (Step 3) of Item 9.3.

Step 1 Remove the DVD lid.

Step 2 Detach FFC cables at connectors. (CN2005 & CN2007)

Step 3 Remove 1 screw.

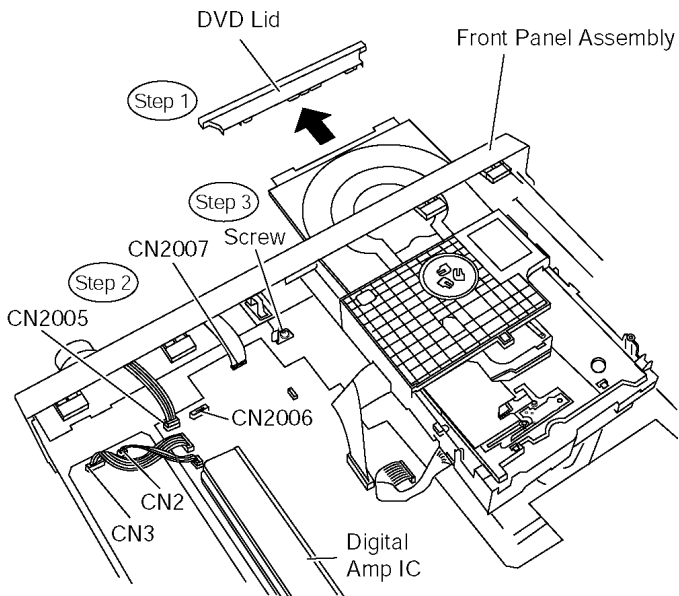

Step 4 Upset the unit and release the tabs.

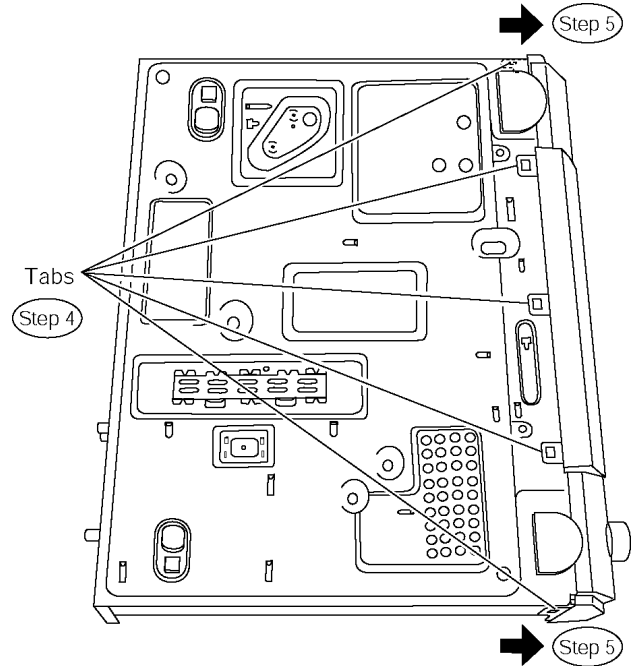

Step 5 Detach the front panel assembly.

Special Note: Avoid placing the set in a position that might cause damage to the jacks when removing the front panel assembly.

9.6. Disassembly of FL P.C.B. & Volume P.C.B.

· Follow the (Step 1) to (Step 5) of Item 9.5 for disassembly of front panel.

· Disassembly of FL P.C.B.

Step 1 Remove 2 screws.

Step 2 Remove the front angle.

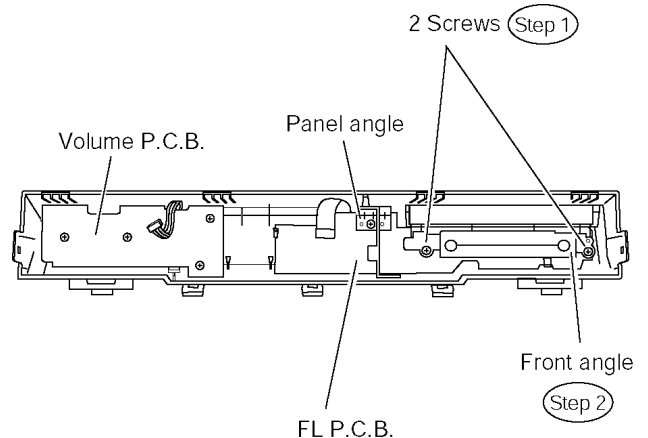

Step 3 Remove 2 screws.

Step 4 Remove the panel angle.

Step 5 Remove FL P.C.B..

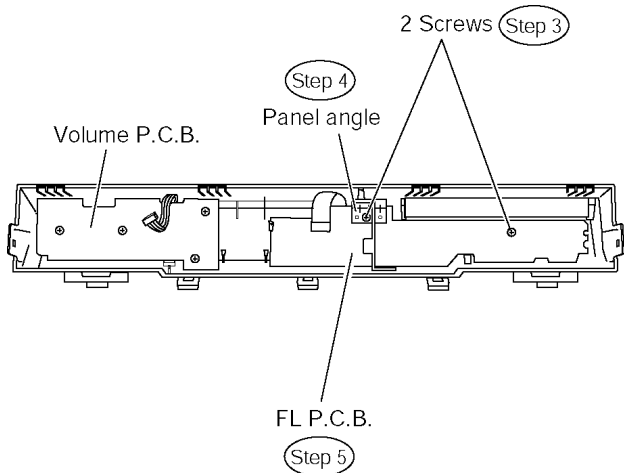

· Disassembly of Volume P.C.B.

Step 6 Remove the volume knob.

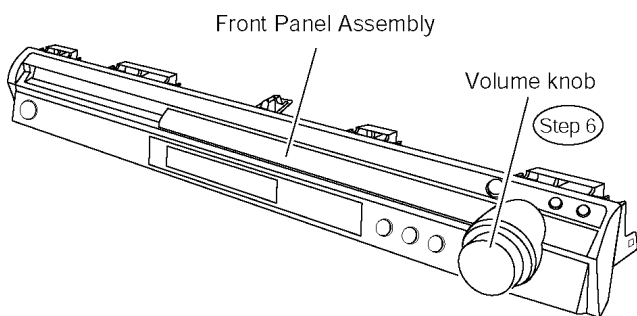

Step 7 Remove 4 screws.

Step 8 Remove Volume P.C.B.

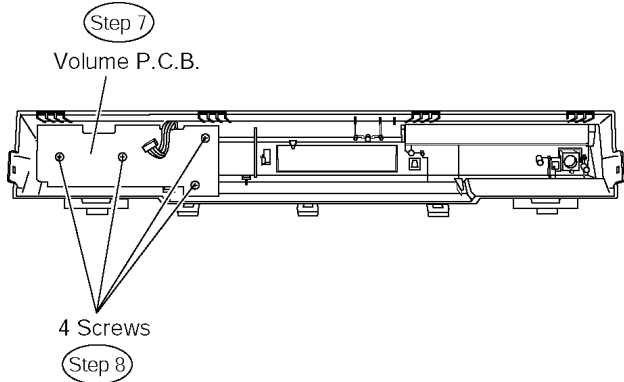

9.7. Disassembly of DVD Mechanism Unit

· Follow (Step 1) to (Step 3) of Item 9.3.

· Follow (Step 1) of Item 9.5.

Step 1 Remove 2 screws.

Step 2 Detach FFC cables at connectors. (CS901, CN2001).

Step 3 Lift up the mechanism unit vertically to remove it.

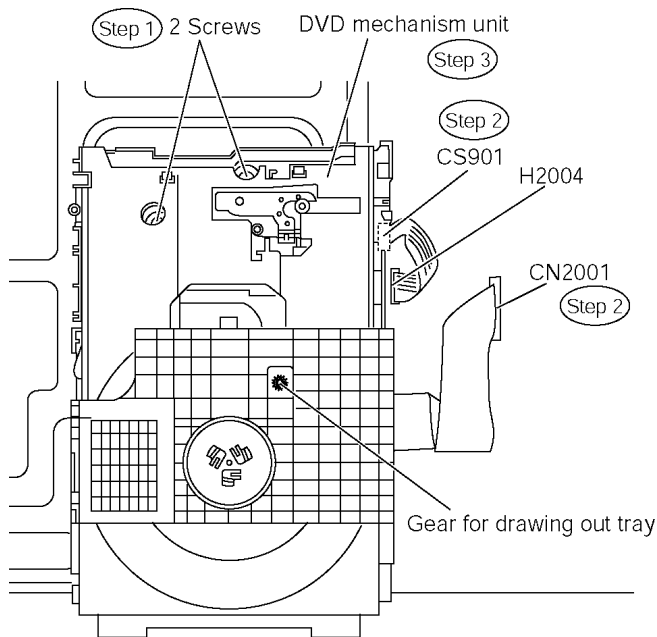

9.8. Disassembly of DVD Module P.C.B.

· Follow (Step 1) to (Step 3) of Item 9.7.

Step 1 Remove 4 screws.

Step 2 Detach FFC cables at the connectors.(FP8251, FP8531)

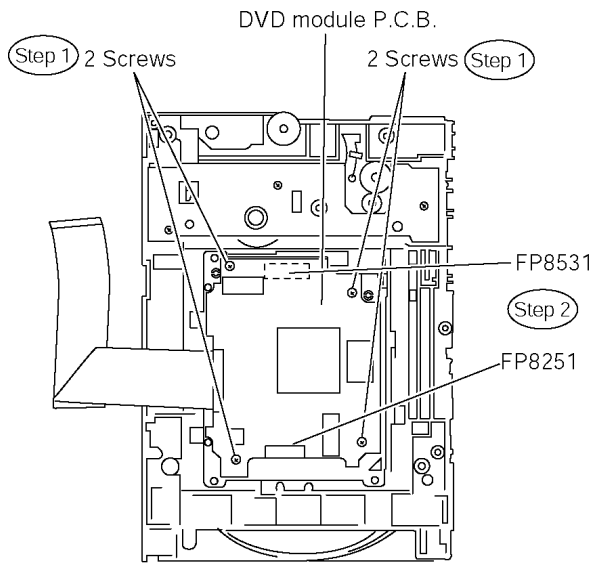

<Mechanism unit bottom>

Caution: Do not apply or exert excessive force when detaching the FFC cables.

9.9. Disassembly of Rear panel

- Follow (Step 1) to (Step 3) of Item 9.3.

Step 1 Remove 8 screws.

Step 2 Detach connector (CN5704) at fan unit.

Caution: Remember to attach the connector of fan unit during assembly.

Step 3 Release the tabs.

Step 4 Remove the rear panel.

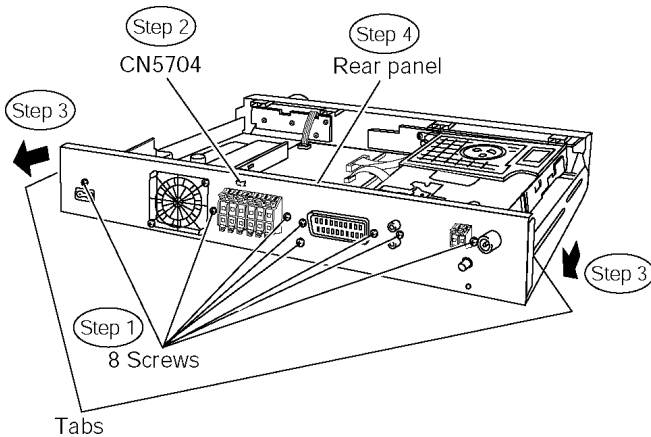

9.10. Disassembly of SMPS Module P.C.B.

Note:

The SMPS Module P.C.B. is replaced as a unit if upon confirmation that it is not working in proper condition. Check for all voltages for confirmation. (Refer to section 14.4) Replace fuse as specified if found broken.

- Follow (Step 1) to (Step 3) of Item 9.3.
- Follow (Step 1) to (Step 4) of Item 9.9.

Step 1 Remove 1 screw.

Step 2 Detach cables at the connectors. (CN2, CN3)

Step 3 Remove SMPS Module P.C.B.

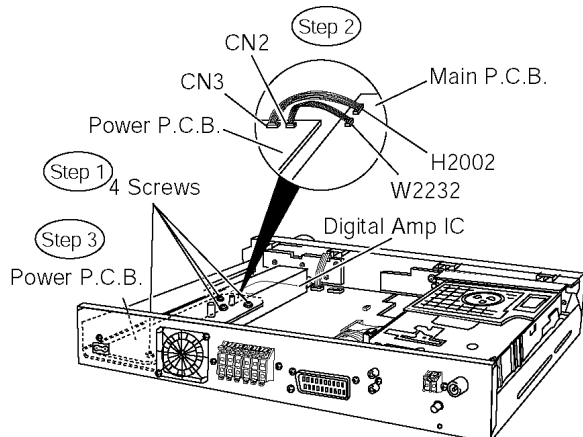

9.11. Disassembly of Main P.C.B. & Tuner Extent P.C.B.

- Follow (Step 1) to (Step 3) of Item 9.3.
- Follow (Step 1) of Item 9.5 for disassembly of DVD lid.
- Follow (Step 1) to (Step 3) of Item 9.7.
- Follow (Step 1) to (Step 4) of Item 9.9.

Step 1 Remove 3 screws.

Step 2 Detach FFC cables at connector (CN2 & CN3).

Step 3 Lift up and remove Main P.C.B.

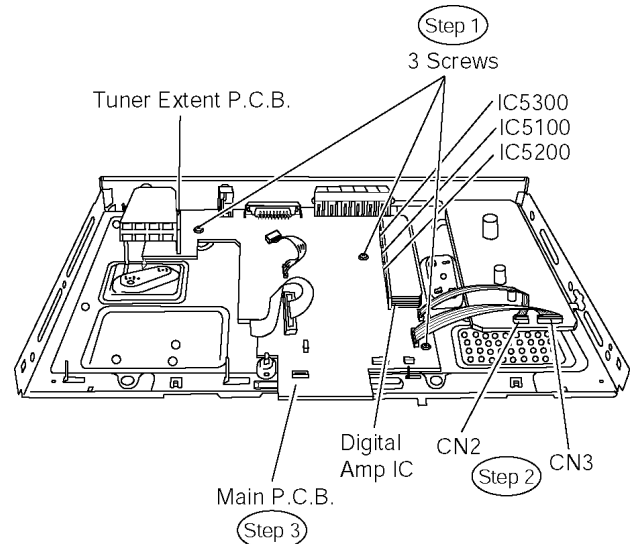

9.12. Disassembly of Digital Amp IC

- Follow (Step 1) to (Step 3) of Item 9.11.

Step 1 Desolder all IC5100, IC5200, IC5300 pins.

Step 2 Remove 2 screws.

Step 3 Remove the Digital Amp IC.

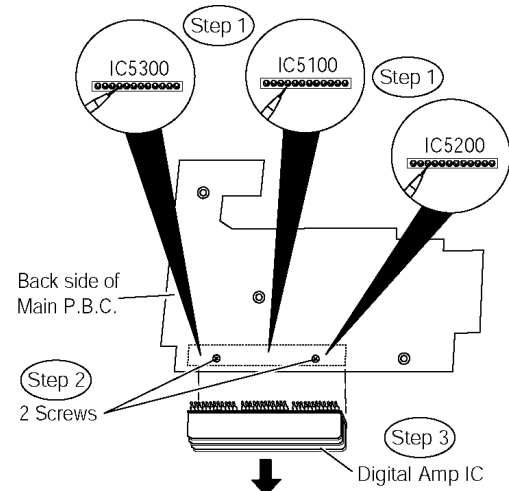

Note: Refer to the diagrams of Main P.C.B. (Section 19.2) for location of the parts.

10 Service Position

10.1. Servicing position of the DVD Module P.C.B.

- Follow Item 9.7.
- Follow (Step 1) of Item 9.8.
- Follow (Step 1) of Item 9.9.

Step 1 Connect FFC cables at connectors. (CN2, CN3, CN2001, CN2005 & CN2007)

Step 2 Connect fan unit (CN5704).

Step 3 Turn mechanism unit to vertical position.

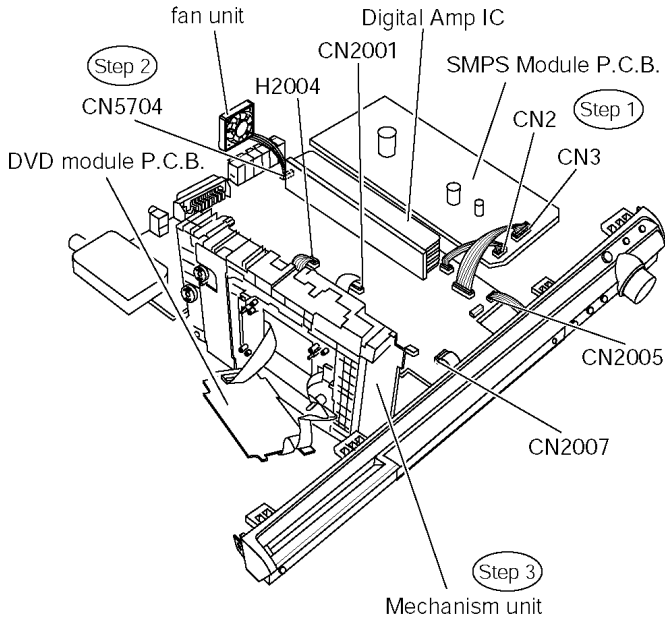

10.2. Servicing position of the Main P.C.B.

- Follow Item 9.7.
- Follow (Step 1) of Item 9.9.

Step 1 Connect FFC cables at connectors. (CN2, CN3, CN2001, CN2005 & CN2007)

Step 2 Connect fan unit (CN5704).

Step 3 Turn over Main P.C.B.

Step 4 Turn mechanism unit to vertical position (as show in illustration) over Main P.C.B.

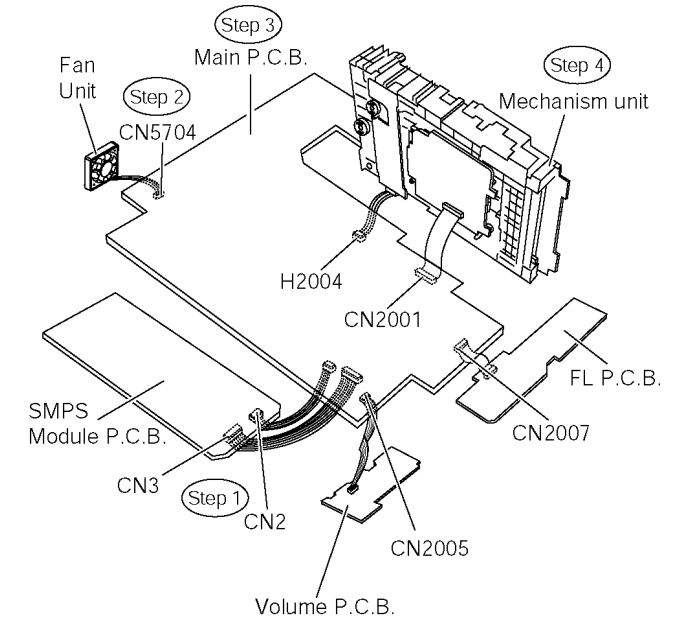

10.3. Servicing position of the SMPS Module P.C.B.

- Follow Item 9.7.
- Follow Item 9.10.
- Follow Item 9.11.

Step 1 Connect FFC cables at connectors. (CN2, CN3, CN2001, CN2005 & CN2007)

Step 2 Connect fan unit (CN5704).

Step 3 Turn over Main P.C.B. & SMPS Module P.C.B.

Step 4 Turn Mechanicm unit to vertical position (as show in illustration) over Main P.C.B.

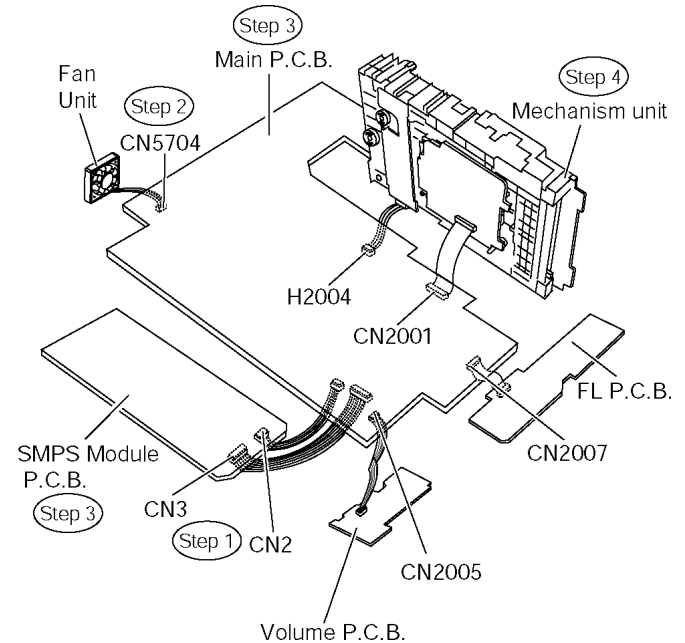

11 Assembly and disassembly of Mechanism Unit

11.1. Disassembly Procedure

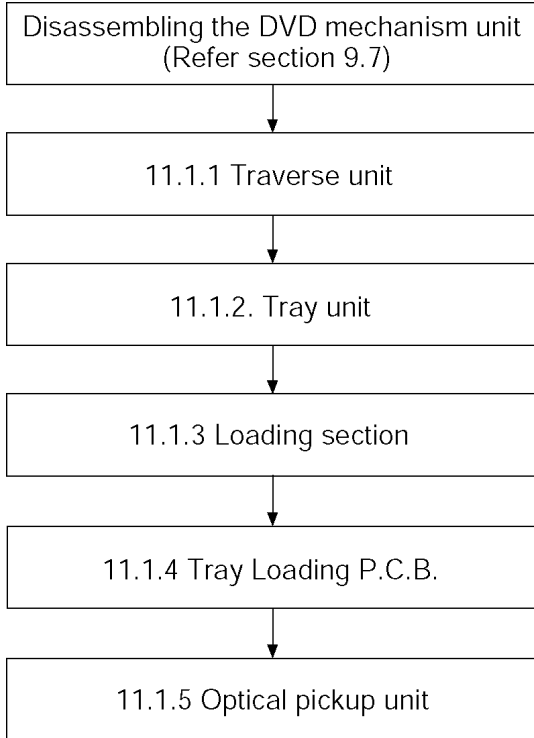

11.1.1. Disassembly of Traverse Unit

Step 1 Slide the lever (A) in the arrow direction (to the opposite side) till it stops.

Step 2 Slide the lever (A) further by bending the tab at the right side of the lever A in the right direction. (The right groove opens and the boss becomes seen.)

Step 3 Open the lever (B) to left. (The 2 grooves at the left side open.)

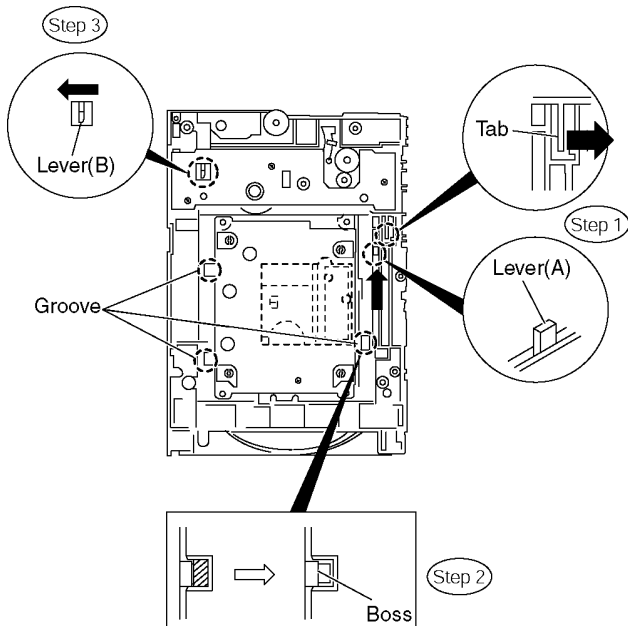

Step 4 Remove the traverse unit.

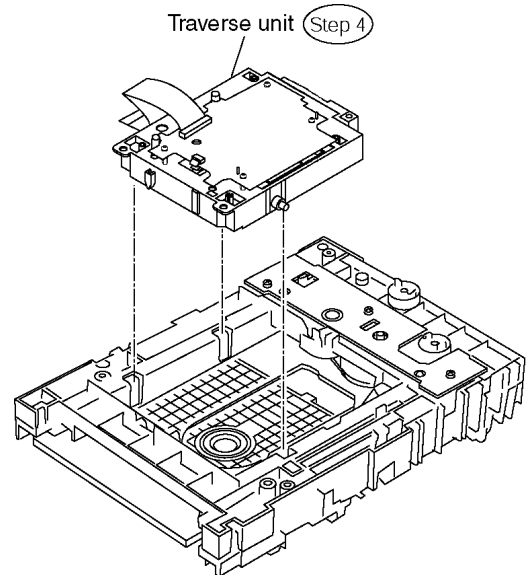

11.1.2. Disassembly of Tray Unit

Step 1 Slide the guide tray unit while pressing the stopper in the arrow direction, and remove the guide tray unit.

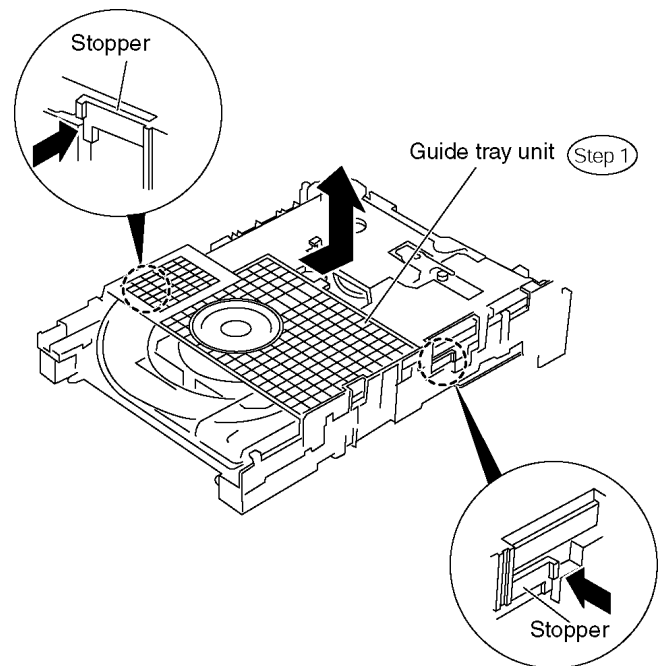

Step 2 Raise the loading unit.

Step 3 Slide the lever in the arrow direction till it stops and pull the tray out.

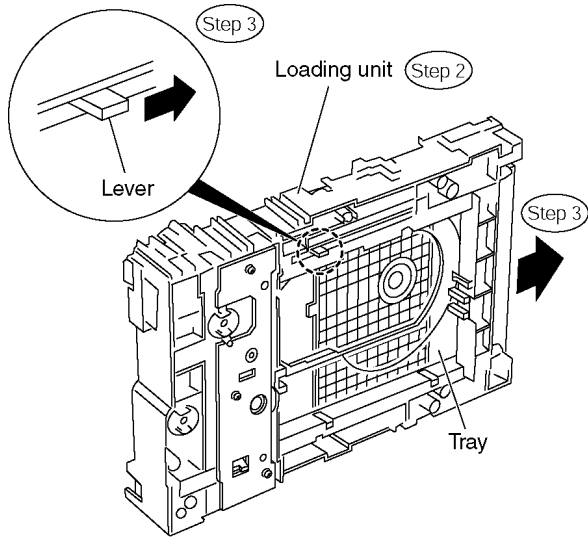

Step 4 Spread the tabs at the both sides and pull the tray out. (The tray slides a little forward and stops.)

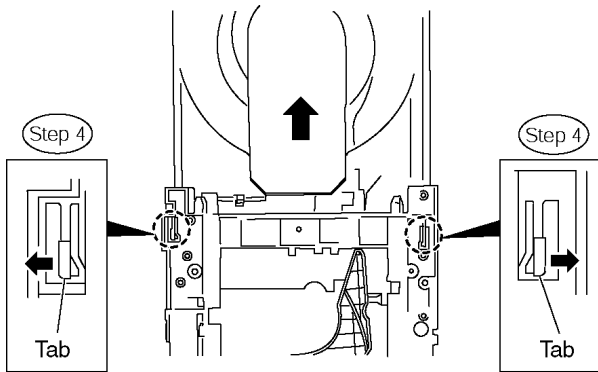

Step 5 Remove the drive arm concave phase from the tray slider and tray.

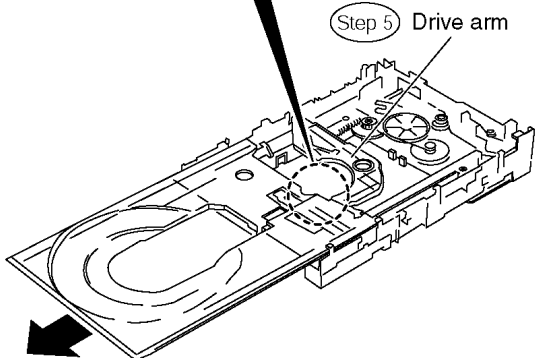
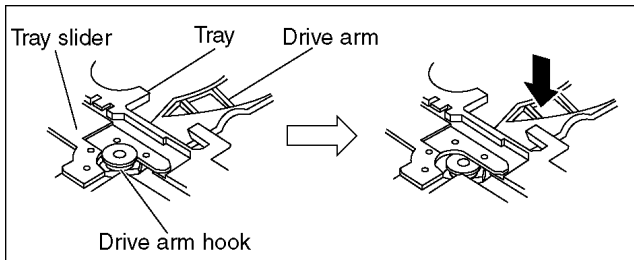

I(Assembling the tray unit)

Step 1 Insert a part of the tray into the unit sliding over the groove on the mechanical chassis unit.

Step 2 Insert the tray to the point before the tab of the mechanical chassis unit.

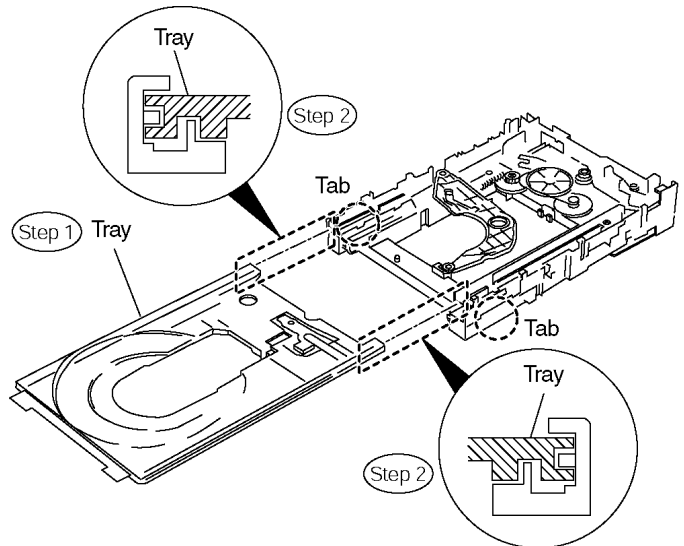

Step 3 Hook the drive arm concave phase over the tray and the tray slider.

Step 4 Press in the tray.

Step 5 Make sure that the tray and the drive arm move smoothly.

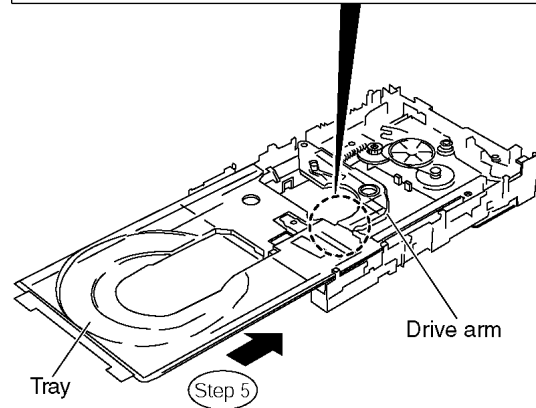
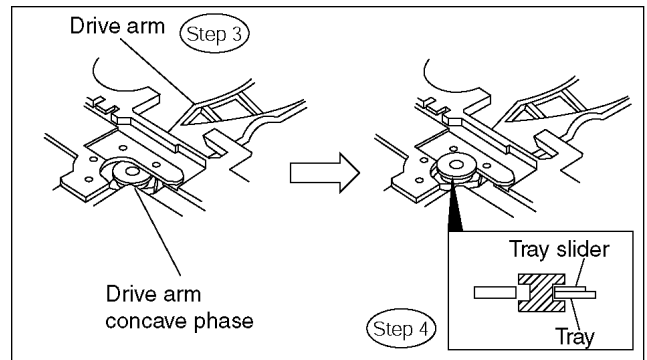

11.1.3. Disassembly of Loading section

Step 1 Spread the tabs at the both sides and push out the drive arm shaft.

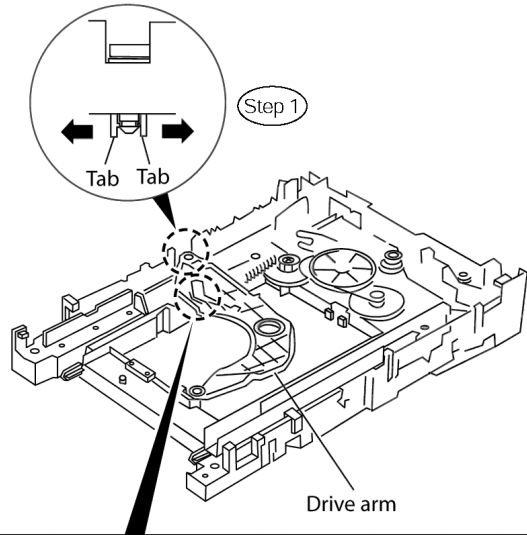

■ Important point in installing the drive rack

- Install the boss the drive rack into the drive arm groove securely.

Step 2 Hook the lock lever spring on the lock lever projection part temporarily.

Step 3 Unlock the tab and remove the lock lever.

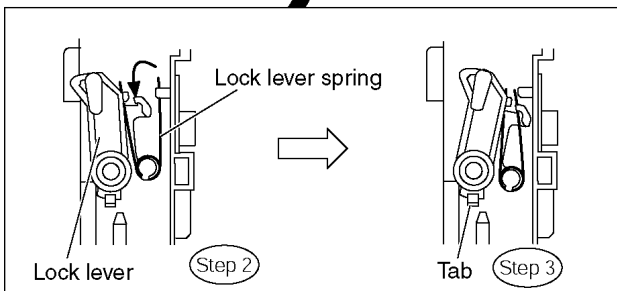
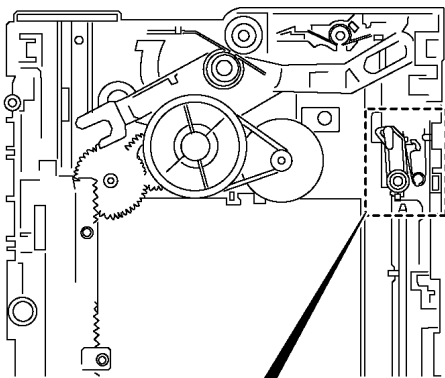

Step 4 Remove the belt.

Step 5 Unlock the tab and remove the pulley.

Step 6 Remove the relay gear.

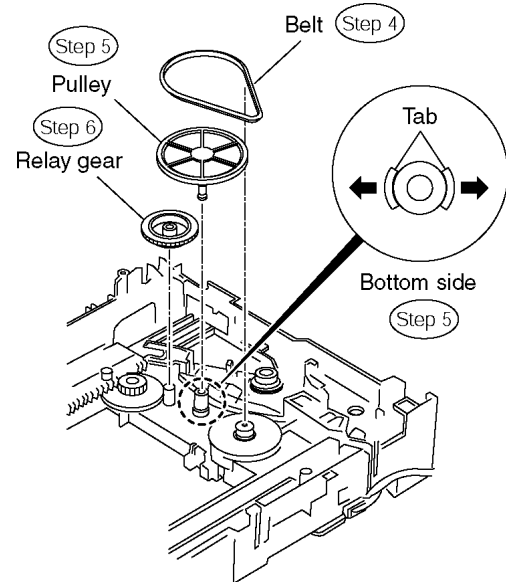

Step 7 Turn the change lever in the arrow direction till it stops.

Step 8 Hook the change lever spring on the change lever project part temporarily.

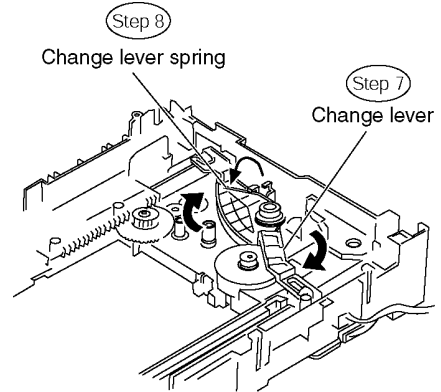

Step 9 Pull the lever (B) in the bottom side to your side and remove the change lever.

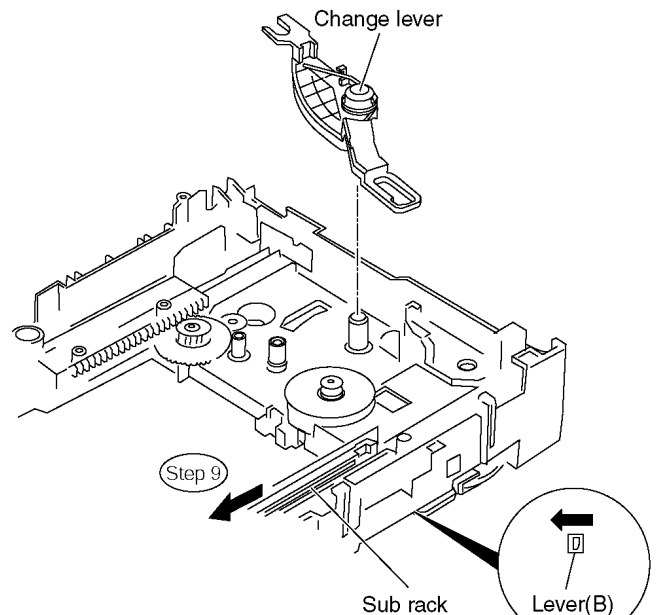

(Bottom side)

Step 10 Remove the drive rack, the sub rack and the drive gear.

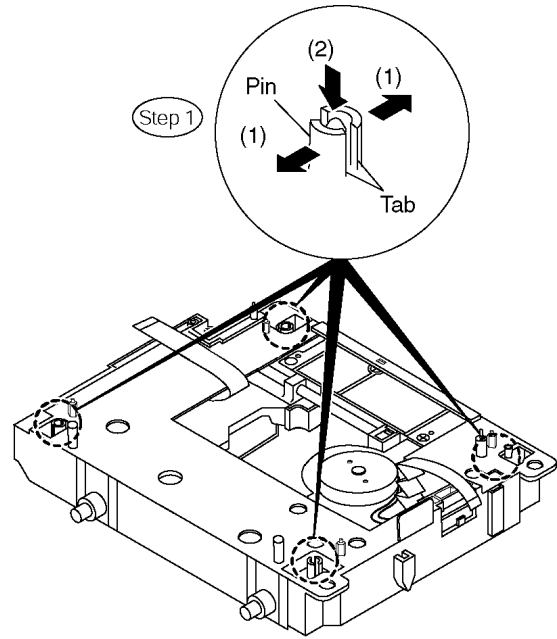
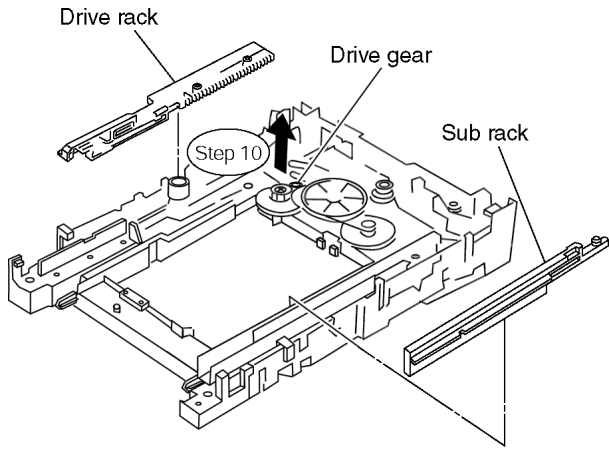

11.1.4. Disassembly of Tray Loading P.C.B.

Step 1 Remove 3 screws

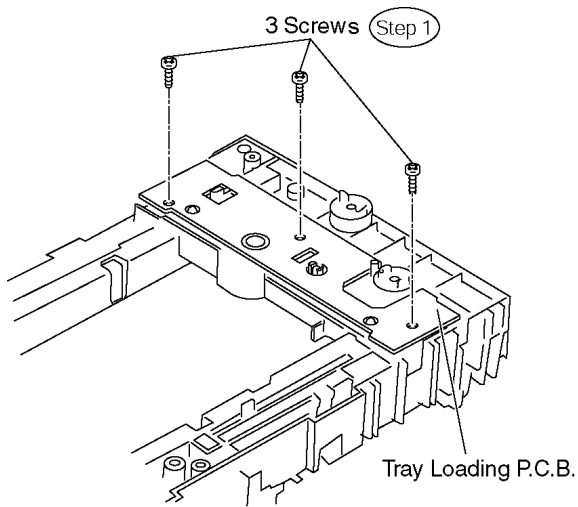

Step 2 Remove 4 pins.

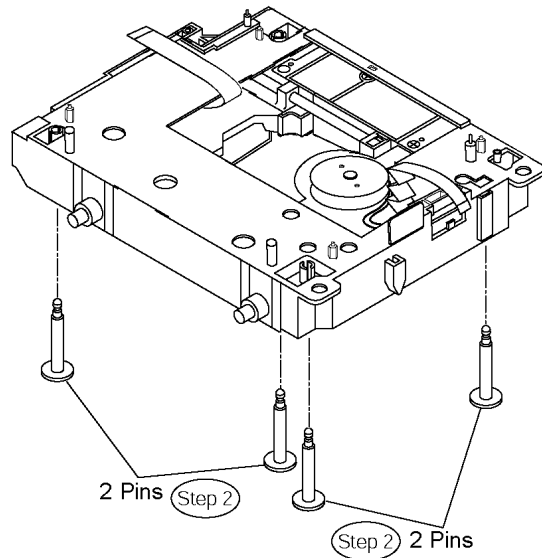

11.1.5. Disassembly of Optical Pickup Unit

Special Note: Anti-static measures are necessary due to handling of OPU unit .

Step 1 Spread the tabs to push in the pin.

Step 3 Remove the middle chassis.

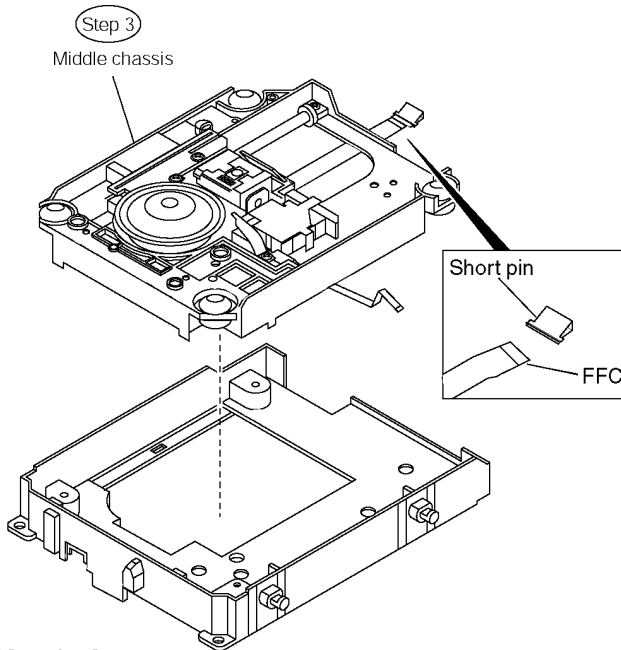
**[Caution]**

Insert the short pin into the FFC of the optical pickup unit.
[See "Caution to be taken in handling the optical pickup unit"]

Step 4 Remove the optical pickup unit in the arrow direction till it stops.

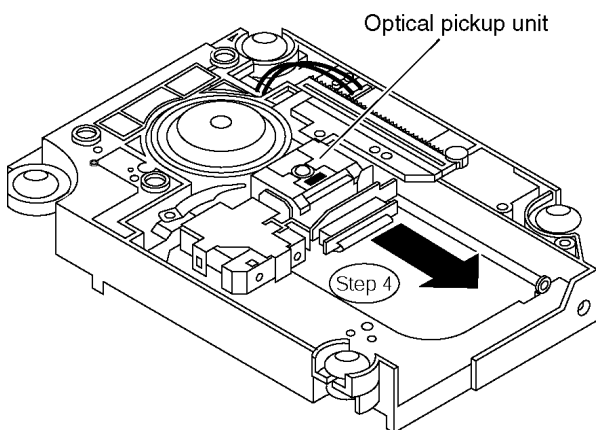

Step 5 Remove 2 screws.

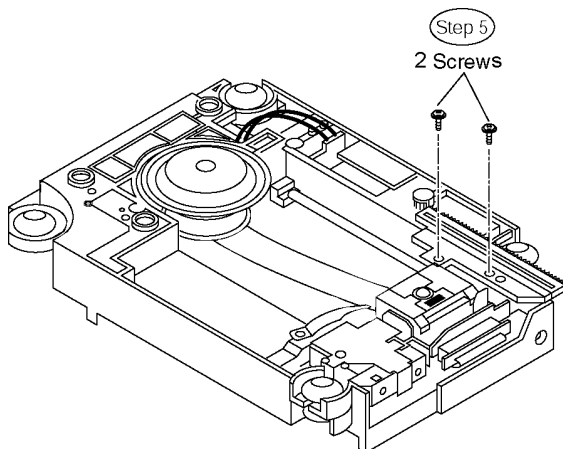

Step 6 Remove the drive rack.

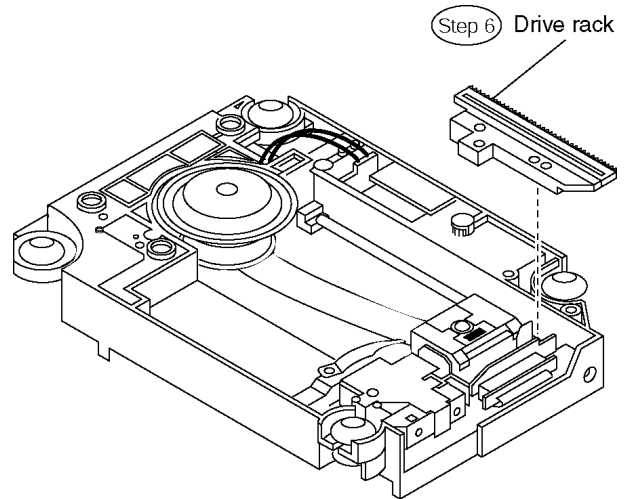

Step 7 Remove 1 screw.

Step 8 Slide the shaft in the arrow direction.

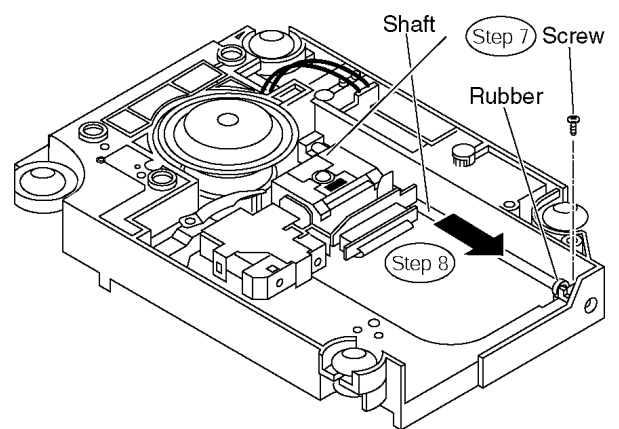

Step 9 Lift the optical pickup unit with the shaft.

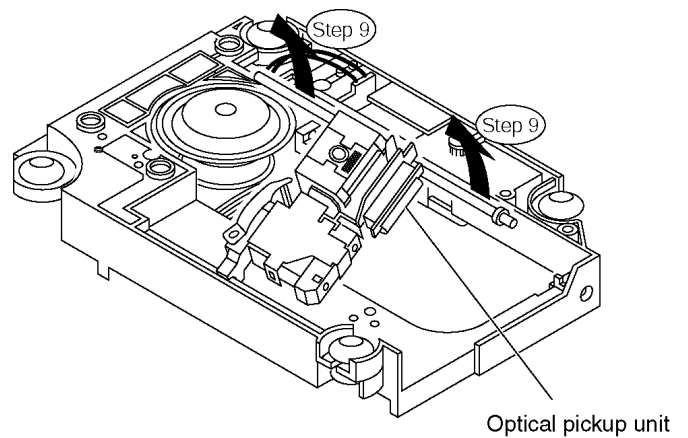

Step 10 Remove the optical pickup unit.

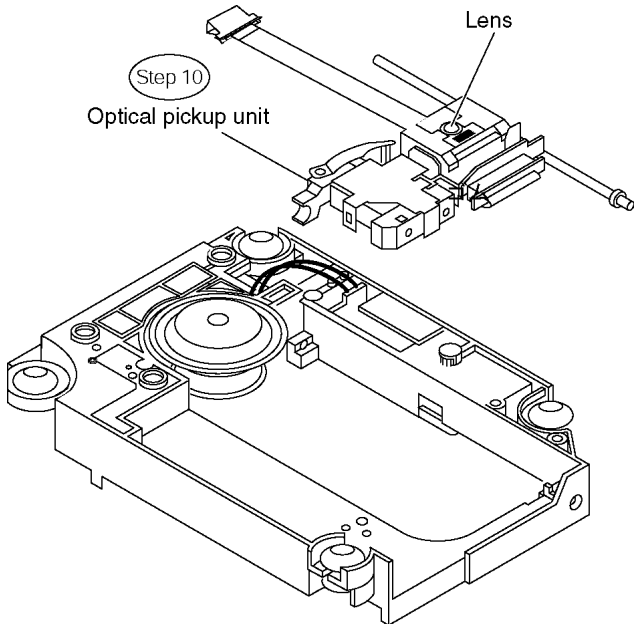

[Caution]

1. Do not give a considerable shock to the optical pickup unit as it has an extremely high-precise structure.
2. Do not touch the lens in the optical pickup unit.

Step 11 Pull the shaft and the rubber out.

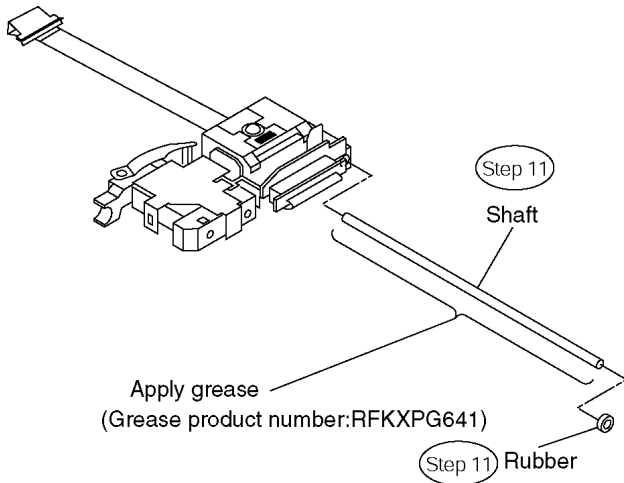

(Assembling the optical pickup unit)

Step 1 Pass the intermediate FPC through the frame hole.

Step 2 Align the guide section of the optical pickup unit with the rail.

Step 3 Install the shaft top to the holder.

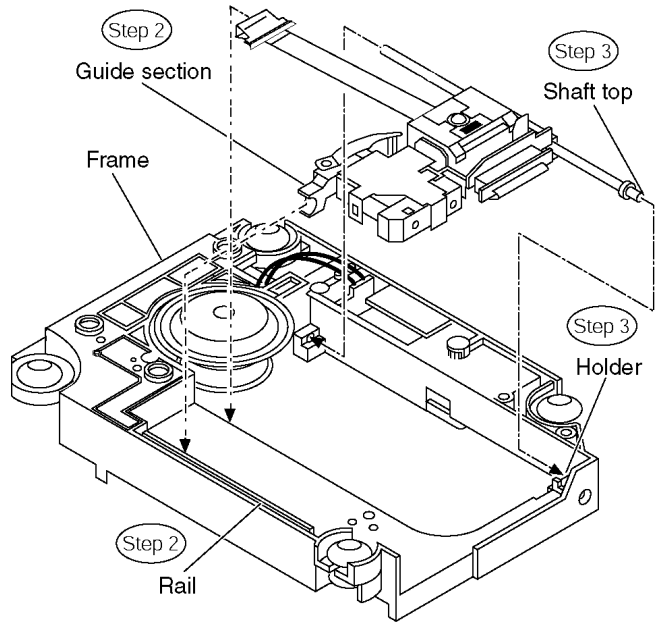

12 Measurements and Adjustments

12.1. Service Tools and Equipment

Application	Name	Number
Tilt adjustment	DVD test disc	DVDT-S20 [SPG]
	TORX screw driver (T6)	Available on sales route. (T6) or RFKZ0185 [SPG]
Others	Grease	RFKXPG641 [SPG]
Confirmation	CD test disc	PVCD-K06 or any other commercially available disc
	VCD test disc	PVCD-K06 or any other commercially available disc
	Recovery disc	RFKZD03R005 [SPG]

12.2. Important points in adjustment

12.2.1. Important points in optical adjustment

- Before starting optical adjustment, be sure to take anti-static measures.
- Optical pickup tilt adjustment is needed after replacement of the following components.

1. Optical pickup unit
2. Spindle motor unit
3. Optical pickup peripheral parts

Notes

Adjustment is generally unnecessary after replacing other parts of the traverse unit. However, make adjustment if there is a noticeable degradation in picture quality. Optical adjustments cannot be made inside the optical pickup. Adjustment is generally unnecessary after replacing the traverse unit.

12.2.2. Important points in electrical adjustment

- Follow the adjustment procedures described in this manual.

12.3. Storing and handling of test discs

- Surface precision is vital for DVD test discs. Be sure to store and handle them carefully.
1. Do not place discs directly onto the workbench, etc., after use.
 2. Handle discs carefully in order to maintain their flatness. Place them into their case after use and store them vertically. Store discs in a cool place where they are not exposed to direct sunlight or air from air conditioners.
 3. Accurate adjustment will not be possible if the disc is warped when placed on a surface made of glass, etc. If this happens, use a new test disc to make optical adjustments.
 4. If adjustment is done using a warped disc, the adjustment will be incorrect and some discs will not be playable.

12.4. Optical adjustment

12.4.1. Optical pickup tilt adjustment

Measurement point	Adjustment point	Mode	Disc
	Tangential adjustment screw Tilt adjustment screw	T01 (inner periphery) play T30 (center periphery) T43 (outer periphery) play	DVDT-S20 [SPG]
Measuring equipment		Adjustment value	
None (Main unit display for servicing is used.)		Adjust to the minimum jitter value.	

12.4.1.1. Adjustment procedure

1. While pressing STOP button on the main unit, press "5" on the remote control unit.
2. Confirm that "J_ xxx/yyy_zz" (display1/display2) is shown on the front display.

For your information:

"yyy" and "zz" shown to the right have nothing to do with the jitter value. "yyy" is the error counter, while "zz" is the focus drive value.

Note:

Jitter value appears on the front display.

3. Play test disc T30 (center periphery).
4. Adjust tangential adjustment screw so that the jitter value is minimized.
5. Play test disc T30 (center periphery).
6. Adjust tilt adjustment screw 1 so that the jitter value is minimized.
7. Play test disc T30 (center periphery).
8. Adjust tilt adjustment screw 2 so that the jitter value is minimized.
9. Repeat adjusting tilt adjustment screws 1 and 2 alternately until the jitter value is minimized.

12.4.1.2. Important points

1. Make tangential adjustment first, and then make tilt adjustment.
2. Repeat adjusting two or three times to find the optimum point.
3. Finish the procedure with tilt adjustment.

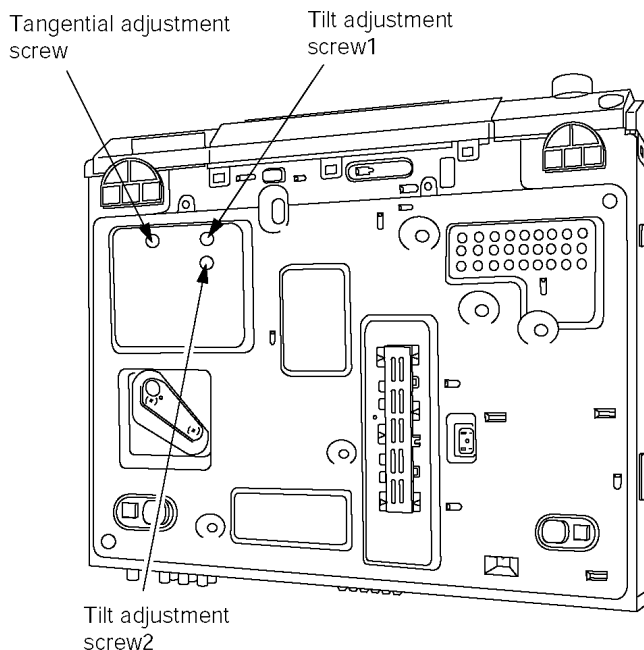
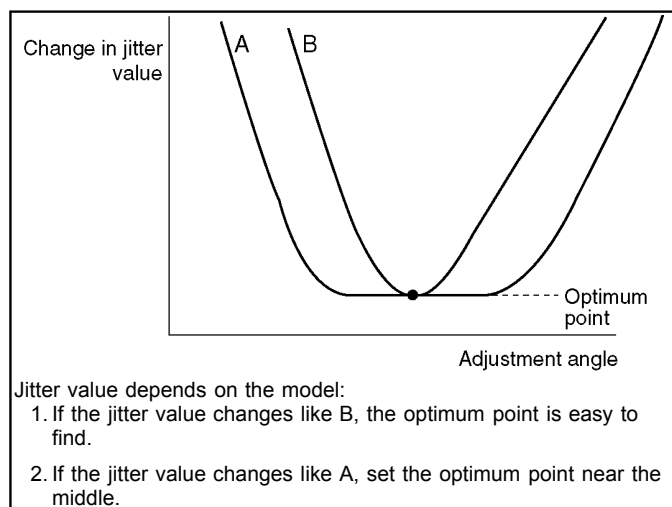

12.4.1.3. Check after adjustment

Play test disc or any other disc to make sure there is no picture degradation in the inner, middle and outer peripheries, and no audio skipping. After adjustment is finished, lock each adjustment screw in position using screw lock.

12.4.1.4. Procedure for screw lock

1. After adjustment, remove top cover, tray, clamper base and traverse unit in this sequence.
2. Lay the traverse unit upside down, and fix adjustment screw with screw lock.
3. After fixing, reassemble traverse unit, clamper base, tray and top cover.

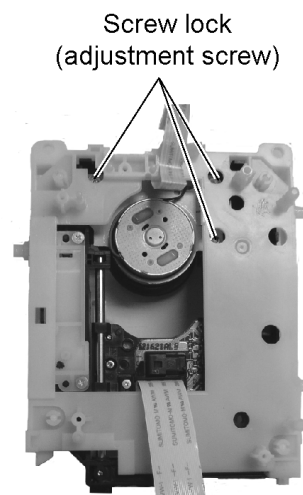

13 Abbreviations

INITIAL/LOGO		ABBREVIATIONS
A	A0~UP	ADDRESS
	ACLK	AUDIO CLOCK
	AD0~UP	ADDRESS BUS
	ADATA	AUDIO PES PACKET DATA
	ALE	ADDRESS LATCH ENABLE
	AMUTE	AUDIO MUTE
	AREQ	AUDIO PES PACKET REQUEST
	ARF	AUDIO RF
	ASI	SERVO AMP INVERTED INPUT
	ASO	SERVO AMP OUTPUT
	ASYNC	AUDIO WORD DISTINCTION SYNC
	B	BCK
BCKIN		BIT CLOCK INPUT
BDO		BLACK DROP OUT
BLKCK		SUB CODE BLOCK CLOCK
BOTTOM		CAP. FOR BOTTOM HOLD
BYP		BYPATH
BYTCK	BYTE CLOCK	
C	CAV	CONSTANT ANGULAR VELOCITY
	CBDO	CAP. BLACK DROP OUT
	CD	COMPACT DISC
	CDSCK	CD SERIAL DATA CLOCK
	CDSRDATA	CD SERIAL DATA
	CDRF	CD RF (EFM) SIGNAL
	CDV	COMPACT DISC-VIDEO
	CHNDATA	CHANNEL DATA
	CKSL	SYSTEM CLOCK SELECT
	CLV	CONSTANT LINEAR VELOCITY
	COFTR	CAP. OFF TRACK
	CPA	CPU ADDRESS
	CPCS	CPU CHIP SELECT
	CPDT	CPU DATA
	CPUADR	CPU ADDRESS LATCH
	CPUADT	CPU ADDRESS DATA BUS
	CPUIRQ	CPU INTERRUPT REQUEST
	CPRD	CPU READ ENABLE
	CPWR	CPU WRITE ENABLE
	CS	CHIP SELECT
	CSYNCIN	COMPOSITE SYNC IN
	CSYNCOUT	COMPOSITE SYNC OUT
	D	DACCK
DEEMP		DEEMPHASIS BIT ON/OFF
DEMPH		DEEMPHASIS SWITCHING
DIG0~UP		FL DIGIT OUTPUT
DIN		DATA INPUT
DMSRCK		DM SERIAL DATA READ CLOCK
DMUTE		DIGITAL MUTE CONTROL
DO		DROP OUT
DOUT0~UP		DATA OUTPUT
DRF		DATA SLICE RF (BIAS)
DRPOUT		DROP OUT SIGNAL
DREQ		DATA REQUEST
DRESP		DATA RESPONSE
DSC		DIGITAL SERVO CONTROLLER
DSLIF		DATA SLICE LOOP FILTER
DVD		DIGITAL VIDEO DISC

INITIAL/LOGO		ABBREVIATIONS
E	EC	ERROR TORQUE CONTROL
	ECR	ERROR TORQUE CONTROL REFERENCE
	ENCSEL	ENCODER SELECT
	ETMCLK	EXTERNAL M CLOCK (81MHz/40.5MHz)
	ETSCLK	EXTERNAL S CLOCK (54MHz)
F	FBAL	FOCUS BALANCE
	FCLK	FRAME CLOCK
	FE	FOCUS ERROR
	FFI	FOCUS ERROR AMP INVERTED INPUT
	FEO	FOCUS ERROR AMP OUTPUT
	FG	FREQUENCY GENERATOR
	FSC	FREQUENCY SUB CARRIER
	FSCK	FS (384 OVER SAMPLING) CLOCK
	G	GND
H		HA0~UP
	HD0~UP	HOST DATA
	HINT	HOST INTERRUPT
	HRXW	HOST READ/WRITE
I	IECOUT	IEC958 FORMAT DATA OUTPUT
	IPFRAG	INTERPOLATION FLAG
	IREF	I (CURRENT) REFERENCE
	ISEL	INTERFACE MODE SELECT
L	LDON	LASER DIODE CONTROL
	LPC	LASER POWER CONTROL
	LRCK	L CH/R CH DISTINCTION CLOCK
M	MA0~UP	MEMORY ADDRESS
	MCK	MEMORY CLOCK
	MCKI	MEMORY CLOCK INPUT
	MCLK	MEMORY SERIAL COMMAND CLOCK
	MDATA	MEMORY SERIAL COMMAND DATA
	MDQ0~UP	MEMORY DATA INPUT/OUTPUT
	MDQM	MEMORY DATA I/O MASK
	MLD	MEMORY SERIAL COMMAND LOAD
	MPEG	MOVING PICTURE EXPERTS GROUP
O	ODC	OPTICAL DISC CONTROLLER
	OFTR	OFF TRACKING
	OSCI	OSCILLATOR INPUT
	OSCO	OSCILLATOR OUTPUT
	OSD	ON SCREEN DISPLAY
P	P1~UP	PORT
	PCD	CD TRACKING PHASE DIFFERENCE
	PCK	PLL CLOCK
	PDVD	DVD TRACKING PHASE DIFFERENCE
	PEAK	CAP. FOR PEAK HOLD
	PLLCLK	CHANNEL PLL CLOCK
	PLLOK	PLL LOCK
	PWMCTL	PWM OUTPUT CONTROL
	PWMDA	PULSE WAVE MOTOR DRIVE A
PWMOA, B	PULSE WAVE MOTOR OUT A, B	

INITIAL/LOGO	ABBREVIATIONS
R	RE RFENV RFO RS RSEL RST RSV
S	SBI0, 1 SBO0 SBT0, 1 SCK SCKR SCL SCLK SDA SEG0~UP SELCLK SEN SIN1, 2 SOUT1, 2 SPDI SPDO SPEN SPRCLK SPWCLK SQCK SQCX SRDATA SRMADR SRMDT0~7 SS STAT STCLK STD0~UP STENABLE STSEL STVALID SUBC SBCK SUBQ SYSCLK
T	TE TIBAL TID TIN TIP TIS TPSN TPSO TPSP TRCRS TRON TRSON
	READ ENABLE RF ENVELOPE RF PHASE DIFFERENCE OUTPUT (CD-ROM) REGISTER SELECT RF POLARITY SELECT RESET RESERVE SERIAL DATA INPUT SERIAL DATA OUTPUT SERIAL CLOCK SERIAL DATA CLOCK AUDIO SERIAL CLOCK RECEIVER SERIAL CLOCK SERIAL CLOCK SERIAL DATA FL SEGMENT OUTPUT SELECT CLOCK SERIAL PORT ENABLE SERIAL DATA IN SERIAL DATA OUT SERIAL PORT DATA INPUT SERIAL PORT DATA OUTPUT SERIAL PORT R/W ENABLE SERIAL PORT READ CLOCK SERIAL PORT WRITE CLOCK SUB CODE Q CLOCK SUB CODE Q DATA READ CLOCK SERIAL DATA SRAM ADDRESS BUS SRAM DATA BUS 0~7 START/STOP STATUS STREAM DATA CLOCK STREAM DATA STREAM DATA INPUT ENABLE STREAM DATA POLARITY SELECT STREAM DATA VALIDITY SUB CODE SERIAL SUB CODE CLOCK SUB CODE Q DATA SYSTEM CLOCK TRACKING ERROR BALANCE CONTROL BALANCE OUTPUT 1 BALANCE INPUT BALANCE INPUT BALANCE OUTPUT 2 OP AMP INPUT OP AMP OUTPUT OP AMP INVERTED INPUT TRACK CROSS SIGNAL TRACKING ON TRAVERSE SERVO ON

INITIAL/LOGO	ABBREVIATIONS
V	VBLANK VCC VCDCONT VDD VFB VREF VSS
W	WAIT WDCK WEH WSR
X	X XALE XAREQ XCDROM XCS XCSYNC XDS XHSYNCO XHINT XI XINT XMW XO XRE XSRMCE XSRMOE XSRMWE XVCS XVDS XVSYNCO
	V BLANKING COLLECTOR POWER SUPPLY VOLTAGE VIDEO CD CONTROL (TRACKING BALANCE) DRAIN POWER SUPPLY VOLTAGE VIDEO FEED BACK VOLTAGE REFERENCE SOURCE POWER SUPPLY VOLTAGE BUS CYCLE WAIT WORD CLOCK WRITE ENABLE HIGH WORD SELECT RECEIVER X' TAL X ADDRESS LATCH ENABLE X AUDIO DATA REQUEST X CD ROM CHIP SELECT X CHIP SELECT X COMPOSITE SYNC X DATA STROBE X HORIZONTAL SYNC OUTPUT XH INTERRUPT REQUEST X' TAL OSCILLATOR INPUT X INTERRUPT X MEMORY WRITE ENABLE X' TAL OSCILLATOR OUTPUT X READ ENABLE X SRAM CHIP ENABLE X SRAM OUTPUT ENABLE X SRAM WRITE ENABLE X V-DEC CHIP SELECT X V-DEC CONTROL BUS STROBE X VERTICAL SYNC OUTPUT

14 Voltage and Waveform Chart

14.1. DVD Module P.C.B.

Ref No.	IC8001																						
MODE	1	2	3	4	5	6	7	8	9	10	11	12	13	14	15	16	17	18	19	20			
CD PLAY	0.1	0.1	3.4	0.1	0.1	0.1	0.1	3.4	0.1	0.1	0.1	0.1	0.1	0.1	0.1	0.1	3.4	2.6	2.6	0.1			
Ref No.	IC8001																						
MODE	21	22	23	24	25	26	27	28	29	30	31	32	33	34	35	36	37	38	39	40			
CD PLAY	-	1.3	1.1	1.2	1.6	1.1	1.5	1.3	1.2	2.5	0.1	1.3	1.0	0.1	3.4	3.3	1.3	1.9	1.1	1.7			
Ref No.	IC8001																						
MODE	41	42	43	44	45	46	47	48	49	50	51	52	53	54	55	56	57	58	59	60			
CD PLAY	1.3	0.7	1.2	0.1	1.3	1.3	1.3	1.5	1.5	2.2	1.3	0.1	-	-	3.4	1.1	2.0	2.2	1.9	1.1			
Ref No.	IC8001																						
MODE	61	62	63	64	65	66	67	68	69	70	71	72	73	74	75	76	77	78	79	80			
CD PLAY	2.2	2.0	2.4	2.7	0.1	3.4	3.4	0.1	3.4	0.1	0.1	0.1	0.1	0.1	0.1	0.1	0.1	0.1	0.1	0.1			
Ref No.	IC8001																						
MODE	81	82	83	84	85	86	87	88	89	90	91	92	93	94	95	96	97	98	99	100			
CD PLAY	0.1	0.1	1.3	3.3	0.1	0.1	3.4	3.4	3.4	2.0	1.6	0.1	3.4	0.1	0.1	0.1	0.1	0.1	0.1	0.1			
Ref No.	IC8001																						
MODE	101	102	103	104	105	106	107	108	109	110	111	112	113	114	115	116	117	118	119	120			
CD PLAY	0.1	3.3	1.0	0.1	2.4	1.9	0.3	0.1	1.8	3.3	3.3	1.3	1.9	1.9	1.9	1.7	1.7	1.7	1.7	2.0			
Ref No.	IC8001																						
MODE	121	122	123	124	125	126	127	128	129	130	131	132	133	134	135	136	137	138	139	140			
CD PLAY	1.5	0.1	0.5	0.1	0.1	1.9	2.3	1.7	2.6	2.6	2.7	2.6	2.7	2.7	2.5	2.6	2.5	2.5	1.8	2.0			
Ref No.	IC8001																						
MODE	141	142	143	144	145	146	147	148	149	150	151	152	153	154	155	156	157	158	159	160			
CD PLAY	1.7	1.7	0.1	1.7	1.7	3.4	0.9	0.9	0.4	3.4	2.0	1.0	1.0	2.0	0	0.4	3.3	3.4	0	3.4			
Ref No.	IC8001																						
MODE	161	162	163	164	165	166	167	168	169	170	171	172	173	174	175	176	177	178	179	180			
CD PLAY	0	1.6	1.7	0.1	1.3	1.2	1.7	1.7	0.9	0.1	0.1	0.9	1.7	0.1	3.4	3.0	3.4	0.1	3.4	0.1			
Ref No.	IC8001																						
MODE	181	182	183	184	185	186	187	188	189	190	191	192	193	194	195	196	197	198	199	200			
CD PLAY	3.0	0.2	2.8	3.4	0.1	0.1	3.4	3.4	0.1	0.1	0.1	0.1	0.1	0.1	0.1	0.1	3.4	3.0	3.0	2.9			
Ref No.	IC8001																						
MODE	201	202	203	204	205	206	207	208	209	210	211	212	213	214	215	216	217	218	219	220			
CD PLAY	3.1	2.9	3.1	3.4	0.1	3.1	3.0	3.0	3.3	3.1	3.0	3.1	3.0	3.4	0.1	2.9	1.3	2.7	2.7	2.7			
Ref No.	IC8001																						
MODE	221	222	223	224	225	226	227	228	229	230	231	232	233	234	235	236	237	238	239	240			
CD PLAY	3.3	0.1	1.7	3.4	1.7	0.1	3.3	3.3	3.2	0.1	2.0	0.1	0.1	1.3	1.7	0.1	0.1	0.1	3.4	1.6			
Ref No.	IC8001																						
MODE	241	242	243	244	245	246	247	248	249	250	251	252	253	254	255	256							
CD PLAY	0.1	1.7	0.2	1.7	0.3	1.6	1.6	0.1	0	0.1	0.1	0.1	0.1	0.1	0.1	0.1							
Ref No.	IC8051																						
MODE	1	2	3	4	5	6	7	8	9	10	11	12	13	14	15	16	17	18	19	20			
CD PLAY	3.4	3.0	3.4	3.1	3.1	0.1	3.1	3.3	3.4	3.0	3.0	0.1	2.9	3.4	2.7	3.3	3.3	3.3	3.2	2.0			
Ref No.	IC8051																						
MODE	21	22	23	24	25	26	27	28	29	30	31	32	33	34	35	36	37	38	39	40			
CD PLAY	1.7	0.1	0.1	0.2	0.3	1.5	3.4	0.1	1.6	1.7	1.7	1.6	0.1	0.1	0.1	-	3.4	1.7	2.7	-			
Ref No.	IC8051																						
MODE	41	42	43	44	45	46	47	48	49	50	51	52	53	54	54								
CD PLAY	0.1	3.0	3.4	3.1	3.0	0.1	3.0	3.2	3.4	2.9	2.9	0.1	3.0	0.1	0.1								
Ref No.	IC8111																						
MODE	1	2	3	4	5	6	7	8															
CD PLAY	3.4	-	0.1	-	4.4	-	-	4.7															
Ref No.	IC8151																						
MODE	1	2	3	4	5																		
CD PLAY	3.0	3.0	0.1	1.3	0.9																		
Ref No.	IC8251																						
MODE	1	2	3	4	5	6	7	8	9	10	11	12	13	14	15	16	17	18	19	20			
CD PLAY	1.7	1.7	1.7	2.2	2.2	1.9	0.1	4.7	3.4	0.1	2.4	2.4	2.4	2.4	4.4	4.5	5.3	3.5	0.1	3.4			
Ref No.	IC8251																						
MODE	21	22	23	24	25	26	27	28	29	30													
CD PLAY	9.2	9.1	1.8	1.7	1.7	3.4	4.3	0	0	0													
Ref No.	IC8421																						
MODE	1	2	3	4	5	6	7	8	9	10	11	12	13	14	15	16	17	18	19	20			
CD PLAY	0	2.3	3.0	3.4	1.7	0.9	1.7	1.7	4.9	0	0.9	0.1	0.1	0	2.4	2.4	4.9	0	2.4	2.4			
Ref No.	IC8421																						
MODE	21	22	23	24	25	26	27	28															
CD PLAY	2.4	2.4	4.9	0	2.5	2.4	2.4	4.8															
Ref No.	IC8601																						
MODE	1	2	3	4																			
CD PLAY	3.3	1.3	0.1	0.1																			
Ref No.	IC8606																						
MODE	1	2	3	4	5																		
CD PLAY	3.3	3.4	0.1	0.1	-																		
Ref No.	IC8611																						
MODE	1	2	3	4	5	6	7	8															
CD PLAY	0.1	0.1	0.1	0.1	3.4	3.4	0.1	3.4															
Ref No.	IC8651																						
MODE	1	2	3	4	5	6	7	8	9	10	11	12	13	14	15	16	17	18	19	20			
CD PLAY	0.7	1.1	2.3	1.3	1.9	1.4	2.2	1.3	1.1	0.1	3.4	3.4	3.4	3.4	-	1.2	2.1	2.2	1.9	1.1			
Ref No.	IC8651																						
MODE	21	22	23	24	25	26	27	28	29	30	31	32	33	34	35	36	37	38	39	40			
CD PLAY	2.2	2.0	2.5	2.7	2.7	2.7	0.1	2.6	0.7	1.1	1.3	1.0	1.6	1.3	1.3	1.5	3.4	1.7	1.2	1.1			
Ref No.	IC8651																						
MODE	41	42	43	44	45	46	47	48															
CD PLAY	1.0	1.1	1.8	1.1	1.7	0.1	3.4	1.4															
Ref No.	IC8691										IC8695												
MODE	1	2	3	4	5						1	2	3	4	5								
CD PLAY	3.0	3.0	0.1	4.2	4.7						2.8	2.8	0.1	3.9	3.9	4.7							
Ref No.	Q8551					Q8552					Q8561					Q8562							
MODE	E	C	B			E	C	B			E	C	B			E	C	B					
CD PLAY	0.1	4.6	0.1			0.1	4.6	4.6			1.9	3.5	1.3			3.5	4.1	4.1					
Ref No.	QR8111					QR8420					QR8571												
MODE	1	2	3	4	5	6			E	C	B			E	C	B							
CD PLAY	0.1	0.1	1.4	0.1	0.1	4.4			0	0.1	4.0			3.4	3.3	0.1							

14.2. Main P.C.B.

Ref.No.	IC1101																								
MODE	1	2	3	4	5	6	7	8	9	10	11	12	13	14	15	16	17	18	19	20					
CD PLAY	5.0	0.1	0.1	2.2	5.0	1.6	0	1.6	2.2	5.0	0.8	0.1	0.7	0	0.7	4.9	2.6	2.6	0.1	3.1					
STANDBY	5.0	0.1	0.1	2.2	5.0	1.6	0	1.6	2.2	5.0	0.9	0.1	0.3	0	0.9	5.0	2.6	2.6	0.1	3.2					
Ref.No.	IC1101																								
MODE	21	22	23	24	25	26	27	28	29	30	31	32													
CD PLAY	3.2	0.1	2.9	3.2	0.1	1.4	1.4	0.1	1.5	1.5	0.1	2.3													
STANDBY	3.1	0.1	3.1	3.1	0.1	1.4	1.4	0.1	1.4	1.4	0.1	2.3													
Ref.No.	IC1102																								
MODE	1	2	3	4	5	6																			
CD PLAY	0	2.6	4.9	2.5	0.1	2.5																			
STANDBY	0	2.6	5.0	2.5	0.6	2.5																			
Ref.No.	IC2004																								
MODE	1	2	3	4	5	6	7	8																	
CD PLAY	-	4.9	0	0	0	0	0	-																	
STANDBY	-	4.8	0	0	0	0	0	-																	
Ref.No.	IC2018																								
MODE	1	2	3	4	5	6	7	8	9	10	11	12	13	14	15	16	17	18	19	20					
CD PLAY	0.1	4.7	4.7	4.7	0	0	4.6	0	0	0	0	4.7	2.4	0	2.3	4.7	4.7	4.7	2.1	0					
STANDBY	0	0	0	0.1	0	0	0	0	0	0	0	4.9	2.5	0	2.4	4.9	4.9	4.8	2.7	0					
Ref.No.	IC2018																								
MODE	21	22	23	24	25	26	27	28	29	30	31	32	33	34	35	36	37	38	39	40					
CD PLAY	0	4.7	0	0	0	0	4.7	4.7	4.7	0	0	0	0	4.6	0	4.0	4.4	4.6	0	4.6					
STANDBY	0	4.8	0	0	0	0	0	0	0	0	0	0	0	0	0	0.1	0.1	0	0	0					
Ref.No.	IC2018																								
MODE	41	42	43	44	45	46	47	48	49	50	51	52	53	54	55	56	57	58	59	60					
CD PLAY	0	4.6	0	0.1	0	0	0	0	0	0	4.7	0	0	0	4.6	4.6	4.6	4.5	4.7	0					
STANDBY	0	0	0	0	0	0	0	0	0	0	0	0	0	0	0	0	0	0	0	0					
Ref.No.	IC2018																								
MODE	61	62	63	64	65	66	67	68	69	70	71	72	73	74	75	76	77	78	79	80					
CD PLAY	0	4.7	4.7	0	0	0	0	4.6	0	4.4	4.7	4.7	2.5	0	0	0	0	0	0	0					
STANDBY	0	4.9	0	0	0	0	0	0	0	0	0	0.7	0	0	0	0	0	0	0	0					
Ref.No.	IC2018																								
MODE	81	82	83	84	85	86	87	88	89	90	91	92	93	94	95	96	97	98	99	100					
CD PLAY	0	0	0	4.7	0	0	4.7	0	0	0	4.7	0	0.7	1.2	0.4	0	1.6	4.8	4.7	4.7					
STANDBY	0	0	0	0	0	0	0	0	0	0	4.8	0	0.7	1.2	0.4	0	1.6	4.9	4.9	0					
Ref.No.	IC2102																								
MODE	1	2	3	4	5	6	7	8	9	10	11	12	13	14	15	16	17	18	19	20					
CD PLAY	0	0	0	0	0	0	0	0	0	0	0	0	0	0	0	0	0	0	0	0					
STANDBY	0	0	0	0	0	0	0	0	0	0	0	0	0	0	0	0	0	0	0	0					
Ref.No.	IC2102																								
MODE	21	22	23	24	25	26	27	28	29	30	31	32	33	34	35	36	37	38	39	40					
CD PLAY	0	0	0	0	0	0	0	0	0	0	0	0.1	0	0	0	0	0	0	0	0.1					
STANDBY	0	0	0	0	0	0	0	0	0	0	0	0.1	0	0	0	0	0	0	0	0.1					
Ref.No.	IC2102																								
MODE	41	42	43	44	45	46	47	48	49	50	51	52	53	54	55	56	57	58	59	60					
CD PLAY	0	0	0	0	0	0	0	0	0	1.3	0	0	0	0.1	0	0	0	0	0	0					
STANDBY	0	0	0	0	0	0	0	0	0	1.4	0	0	0	0.1	0	0	0	0	0	0					
Ref.No.	IC2102																								
MODE	61	62	63	64	65	66	67	68	69	70	71	72	73	74	75	76	77	78	79	80					
CD PLAY	0	-0.1	0	0	4.8	0	5.6	0	0	0	0	0	0	0	0	0	0	0	0	0					
STANDBY	0	-0.1	0	0	4.8	0	5.6	0.1	0	0	0	0	0	0	0	0	0	0	0	0					
Ref.No.	IC2102																								
MODE	81	82	83	84	85	86	87	88	89	90	91	92	93	94	95	96	97	98	99	100					
CD PLAY	0	0	0	0	-6.2	6.3	0	0	0	0	0	0	0	0	0	0	0	0	0	0					
STANDBY	0	0	0	0	-6.4	6.5	0	0	0	0	0	0	0	0	0	0	0	0	0	0					
Ref.No.	IC2903																								
MODE	1	2	3	4	5	6	7																		
CD PLAY	2.7	10.5	6.0	0	-	1.1	0.7																		
STANDBY	2.8	10.5	6.0	0	-	1.1	0.7																		
Ref.No.	Q1001					Q1002					Q1003					Q1004					Q1005				
MODE	E	C	B		E	C	B		E	C	B		E	C	B		E	C	B						
CD PLAY	0	0	0		0.1	12.5	0.1		11.9	13.0	12.6		0	12.6	0		12.0	13.0	12.6						
STANDBY	3.4	3.3	0		0.1	12.5	0.1		11.9	13.0	12.6		0	12.6	0		12.3	12.7	12.7						
Ref.No.	Q1006					Q1007					Q1100					Q1200									
MODE	1	2	3	4	5	6		E	C	B		E	C	B		E	C	B		E	C	B			
CD PLAY	4.9	4.9	4.9	0	0	0.1		12.0	12.0	0.1		0.3	0	0		0.4	0	0		0	0	0			
STANDBY	4.9	4.9	4.9	0.1	0	0.1		12.3	-	12.3		0	0	0.8		0	0	0.8		0	0	0.8			
Ref.No.	Q2003					Q2004					Q2006					Q2030					Q2805				
MODE	E	C	B		E	C	B		E	C	B		E	C	B		E	C	B		E	C	B		
CD PLAY	0	2.2	0		0	0	4.5		1.1	0	0.5		0	0	4.7		4.3	5.4	4.9		0	2.7	0		
STANDBY	0	0.1	0		0	0	0		0	0	0		0	0	4.6		0	0	0		0	0	0		
Ref.No.	Q2903					Q2904					Q2905					Q2906					Q2907				
MODE	E	C	B		E	C	B		E	C	B		E	C	B		E	C	B		E	C	B		
CD PLAY	6.3	6.3	6.9		6.2	9.2	6.9		0	5.2	0		-7.5	-23.3	-7.0		-6.3	-21.0	-6.8		0	2.8	0		
STANDBY	6.5	6.5	7.1		6.2	9.2	6.9		0	5.2	0		-7.5	-23.3	-7.0		-6.9	-21.0	-6.4		0	2.8	0		
Ref.No.	Q2910					Q2913					Q2914					Q2915					Q2916				
MODE	E	C	B		E	C	B		E	C	B		E	C	B		E	C	B		E	C	B		
CD PLAY	12.9	21.2	13.5		9.2	11.1	9.8		3.2	3.5	3.7		4.7	4.9	4.7		0	2.7	0		0	2.7	0		
STANDBY	12.9	21.2	13.5		9.2	11.2	9.8		3.2	3.2	3.8		4.6	4.8	4.7		0	2.8	0		0	2.8	0		
Ref.No.	Q2917					Q2955					Q2974					Q2980									
MODE	E	C	B		E	C	B		E	C	B		E	C	B		E	C	B		E	C	B		
CD PLAY	2.9	0	0		5.1	5.7	5.7		-21.8	-25.4	-22.4		0	25.9	0		0	25.9	0		0	25.9	0		
STANDBY	0	0	-2.9		5.1	5.7	5.7		-21.7	-25.3	-22.3		0	26.0	0		0	26.0	0		0	26.0	0		

Ref No.	IC5100																							
MODE	1	2	3	4	5	6	7	8	9	10	11	12												
CD PLAY	25.9	12.7	0	12.6	4.7	0	0	0	0	12.7	0	12.7												
STANDBY	26.0	12.8	0	12.7	4.7	0	0	0	3.0	12.8	0	12.8												
Ref No.	IC5200																							
MODE	1	2	3	4	5	6	7	8	9	10	11	12												
CD PLAY	25.9	12.7	0	12.7	4.7	0	0	0	3.0	12.7	0	12.7												
STANDBY	26.0	12.7	0	12.7	4.7	0	0	0	3.0	12.8	0	12.7												
Ref No.	IC5300																							
MODE	1	2	3	4	5	6	7	8	9	10	11	12												
CD PLAY	25.9	12.7	0	13.0	4.7	0	0	0	0	12.7	0	12.8												
STANDBY	25.6	12.7	0	12.7	4.6	0	0	0	3.0	12.7	0	12.8												
Ref No.	Q3003			Q3008			Q3009																	
MODE	E	C	B	E	C	B	E	C	B															
CD PLAY	1.6	1.6	0	0	0	0.6	0	0.2	0.2															
STANDBY	1.6	1.6	0	0	0	0.6	0	0.1	0															
Ref No.	Q5740			Q5741			Q5742																	
MODE	E	C	B	E	C	B	E	C	B															
CD PLAY	8.9	17.1	9.5	0	4.9	0	0	0.1	0.7															
STANDBY	8.9	17.1	9.5	0	4.9	0	0	0.1	0.7															
Ref No.	Q5744			Q5745			Q5746																	
MODE	1	2	3	1	2	3	4	E	C	B														
CD PLAY	0	4.6	0.1	5.6	4.4	0	0.4	0	0.1	4.8														

14.3. FL P.C.B. & Tray Loading P.C.B.

FL P.C.B.

Ref No.	IC6901																				
MODE	1	2	3	4	5	6	7	8	9	10	11	12	13	14	15	16	17	18	19	20	
CD PLAY	4.9	0	0	-0.1	2.8	-	0.7	4.6	3.7	-	-	0	4.8	-21.0	-21.0	-18.9	-18.8	-14.7	-18.9	-14.7	
STANDBY	4.9	0	0	0	2.8	-	0.7	4.6	3.7	-	-	0	4.9	-21.0	-21.0	-21.0	-18.9	-10.5	-8.4	-14.7	
Ref No.	IC6901																				
MODE	21	22	23	24	25	26	27	28	29	30	31	32	33	34	35	36	37	38	39	40	
CD PLAY	-12.9	-21.0	-21.0	-14.7	-14.7	-18.9	-21.0	-21.0	-16.8	-21.4	-14.9	-12.8	-19.1	-19.1	-19.1	-19.1	-19.1	-19.1	-19.1	-19.1	
STANDBY	-14.7	-21.0	-18.9	-10.5	-10.5	-16.8	-21.0	-18.9	-8.4	-21.4	-12.7	-10.6	-19.1	-19.1	-19.1	-19.1	-19.1	-19.1	-19.1	-19.1	
Ref No.	IC6901																				
MODE	41	42	43	44																	
CD PLAY	-19.1	-19.1	4.9	-0.1																	
STANDBY	-19.1	-19.1	4.9	0																	

Tray Loading P.C.B.

Ref No.	IC904																		
MODE	1	2	3	4	5	6	7	8	9										
CD PLAY	4.7	8.0	0.6	8.0	0.1	8.0	0.6	2.7	4.7										
STANDBY	0	1.8	0.8	1.8	0	2.1	0.9	4.9	0										

14.4. SMPS Module P.C.B.

SMPS Module P.C.B.

Ref No.	CN2						CN3												
MODE	1	2	3	4			1	2	3	4	5	6	7	8	9	10	11		
CD PLAY	18.5	18.5	0	0			6	3.5	0	10.5	0	0	5	-12.3	-16.1	5.2	24.7		
STANDBY	18.5	18.5	0	0			6	3.5	0	10.5	0	0	5	-12.2	-16.0	5.2	-24.7		

14.5. Waveform Chart

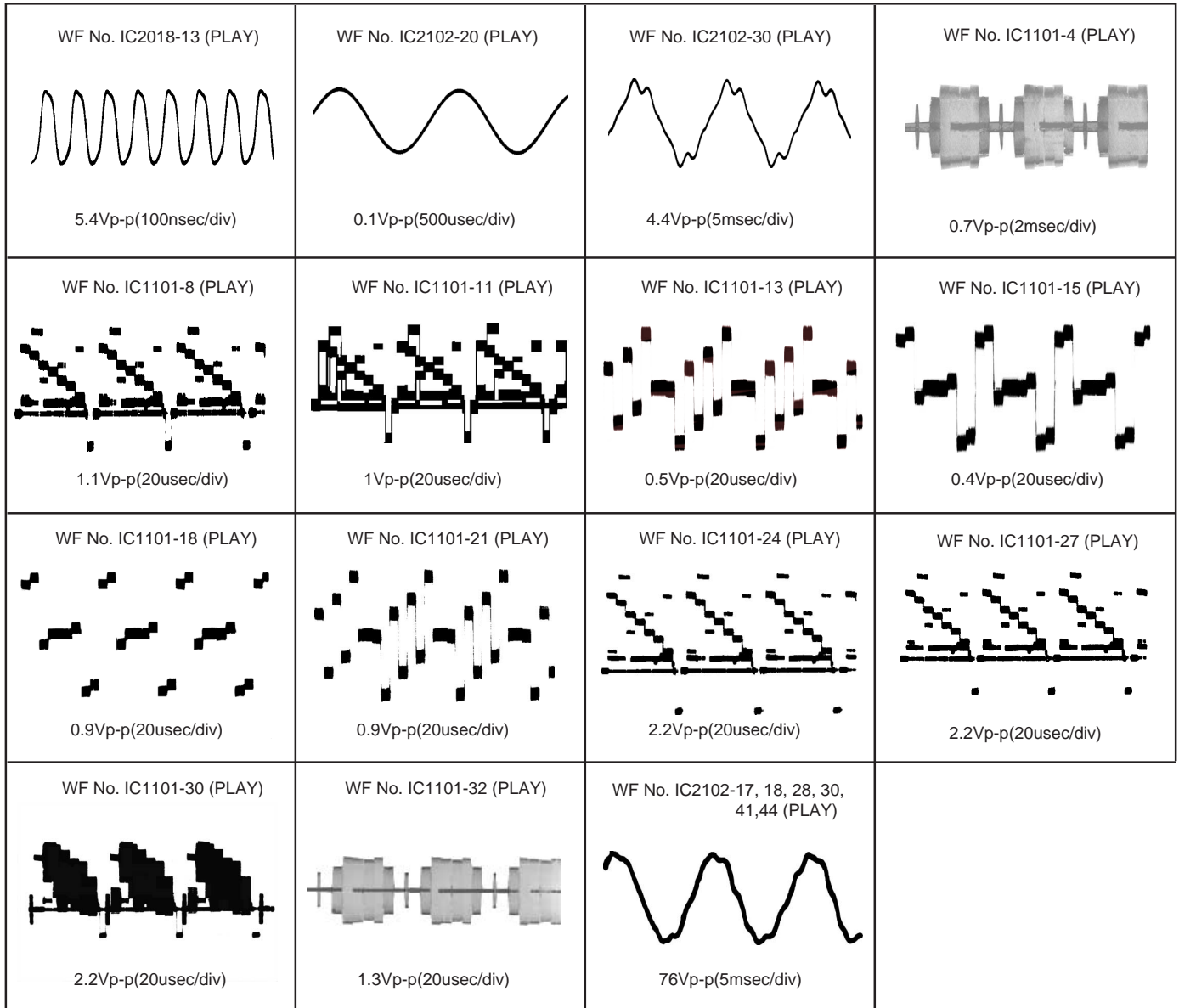

15 Illustration of IC's, Transistors and Diodes

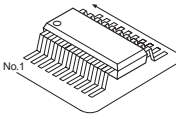
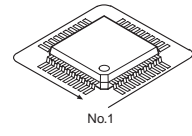
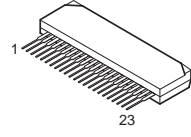
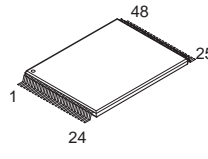
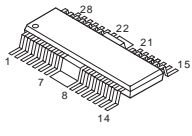
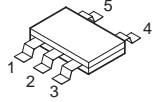
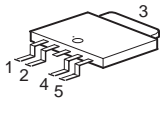
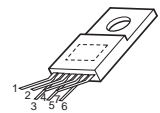
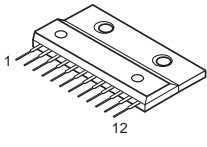
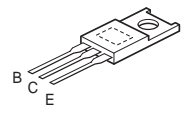
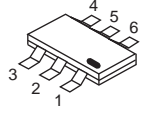
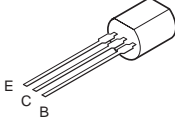
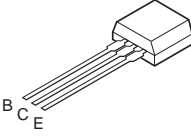
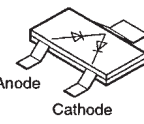
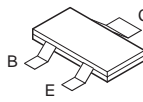
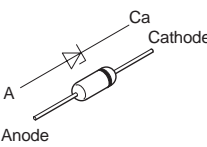
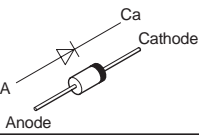
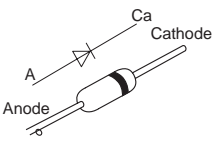
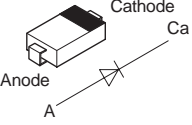
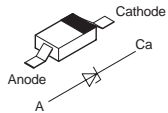
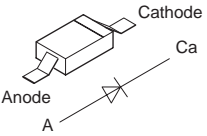
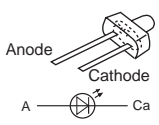
 <p>C0CBCBD00018 (8p) C0EBA000029 (4p) C0FBBK000050 (28p) C1AB00001731 (6p) C3ABPG000145 (54p) C3EBEG000072 (8p) C3EBGC000055 (8p) C9ZB00000461 (32p)</p>		 <p>C0HBB0000057 (44p) C1AB00002463 (100p) C2CBYY000194 (100p) MN864701 (164p) MN2DS0009VP (256p)</p>		 <p>C0GAY0000013</p>		 <p>RFKWMHA0B160</p>					
<p>C0GBG0000048</p> 		<p>C0EBE0000455 C0JBAA000346</p> 		<p>C0DBEHG00006</p> 		<p>AN30070A</p> 		<p>AN17831A</p> 		<p>B1BACG000023 B1BCCG000002</p> 	
<p>XN0460100L XP0621400L</p> 		<p>B1AAKD000012 B1ACKD000005</p> 		<p>B1BACD000018</p> 		<p>B0ADCJ000020</p>  <p>Anode Cathode</p>		<p>2SD1819A0L B1ABCF000176 B1ABGC000005 B1ADCF000001</p> 		<p>B1ADCE000012 B1ADGB000008 B1GBCFJJ0051 B1GDCFJJ0047 UNR511V00L UNR521100L</p>	
<p>B0BC5R600003</p>  <p>Anode Cathode</p>		<p>B0EAKM000117</p>  <p>Anode Cathode</p>		<p>MA2J72800L</p>  <p>Anode Cathode</p>		<p>B0ACCK000005</p>  <p>Anode Cathode</p>		<p>B0BC01200019 B0BC01000014 B0BC013A0007 B0BC5R000009 B0BC3R400001</p>		<p>B0BC7R500001 B0JCPD000025</p>  <p>Anode Cathode</p>	
<p>MA2J11100L MAZ82200ML</p>  <p>Anode Cathode</p>		<p>B3AAA0000803</p>  <p>Anode Cathode</p>									

16 Wiring Connection Diagram

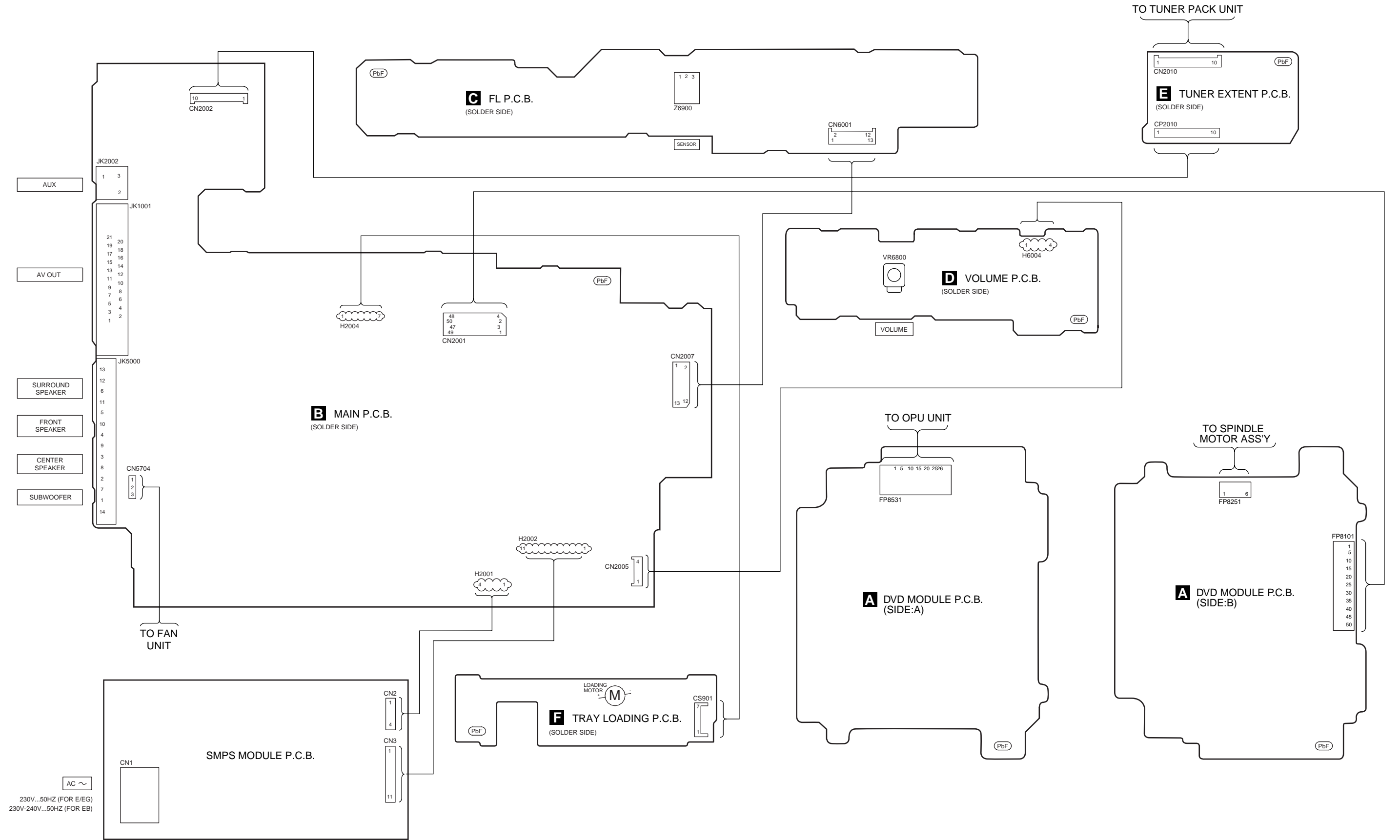

SA-HT340E/EB/EG WIRING CONNECTION

17 Block Diagram

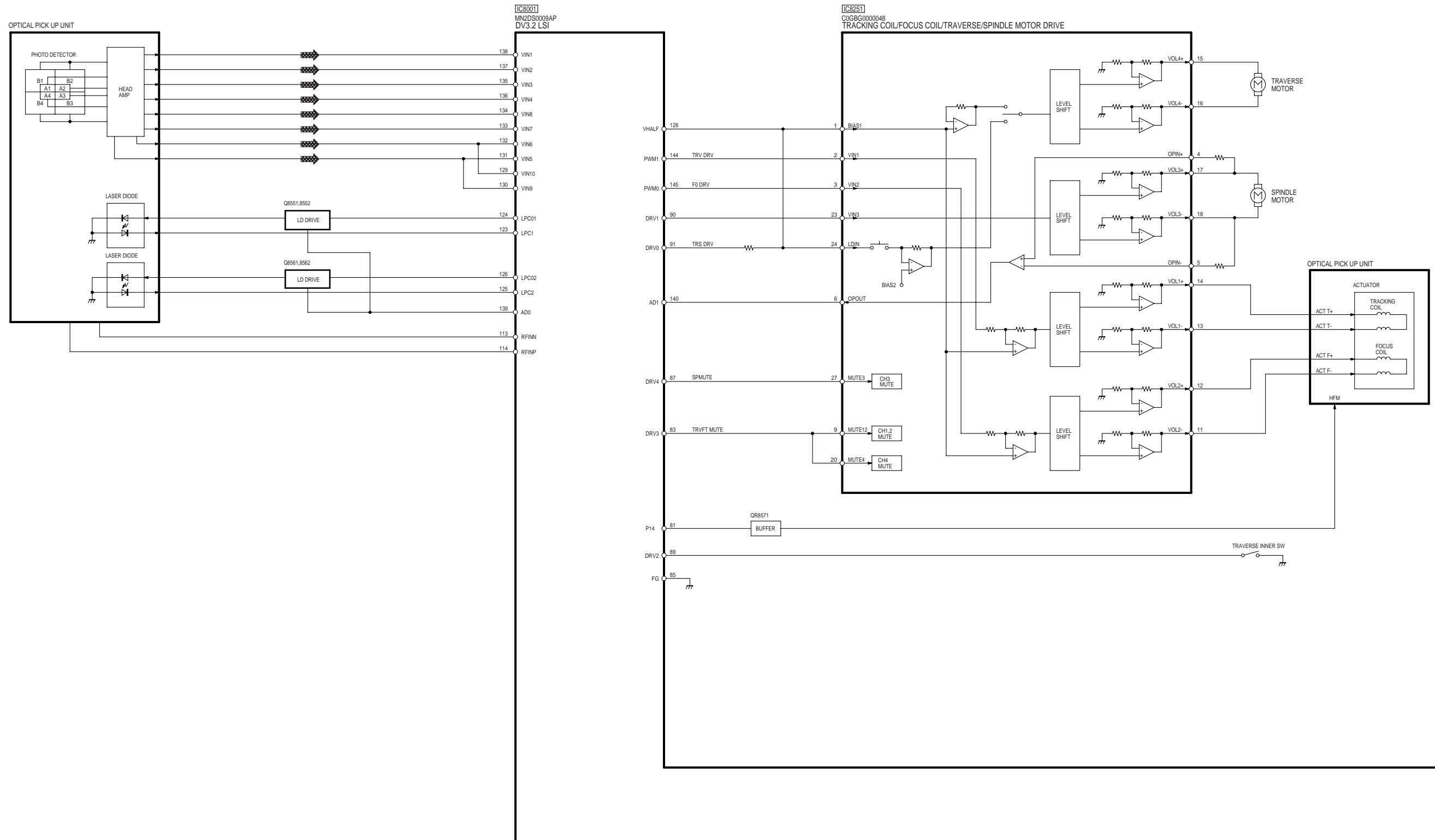

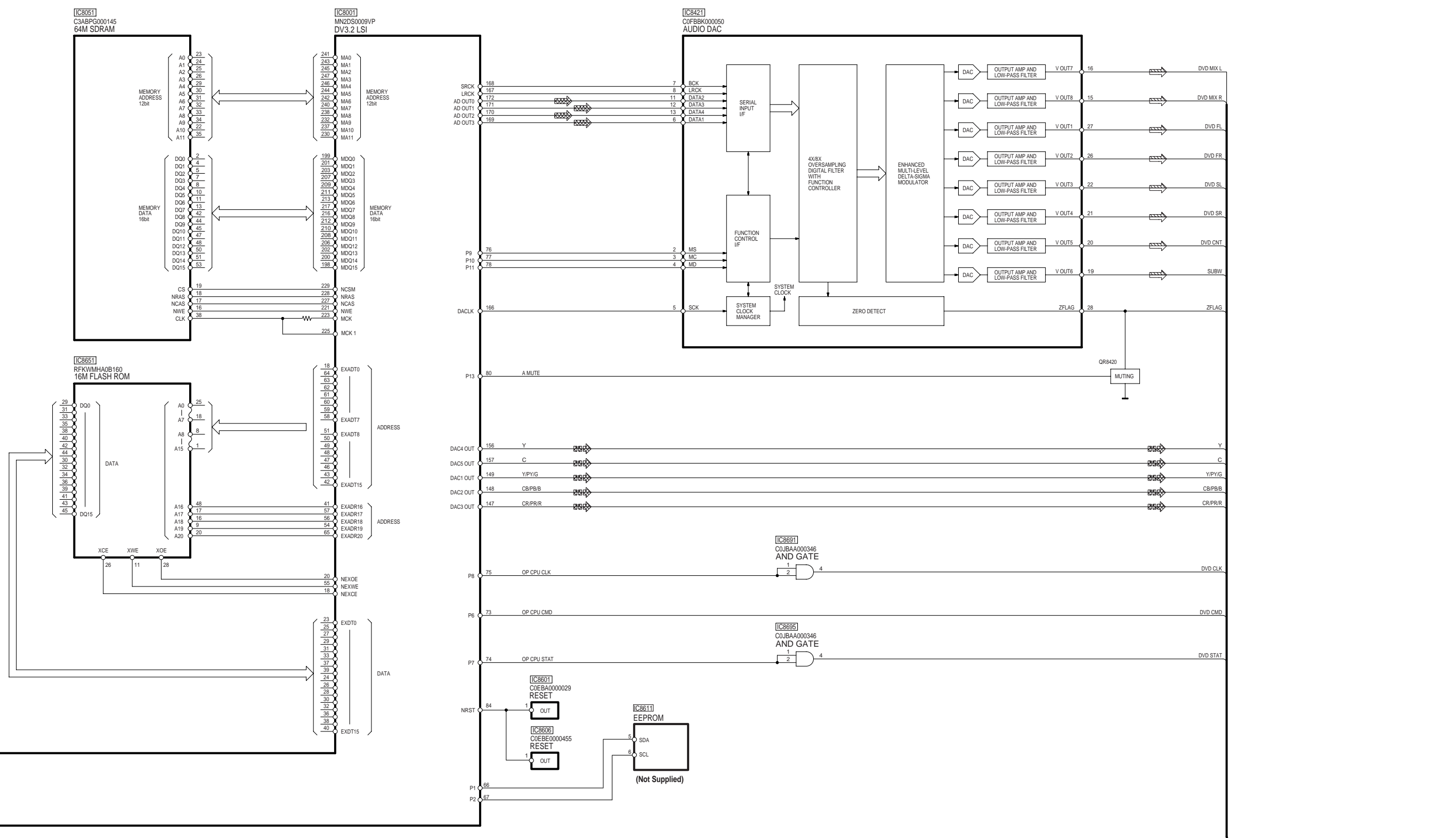

SA-HT340E/EB/EG BLOCK DIAGRAM

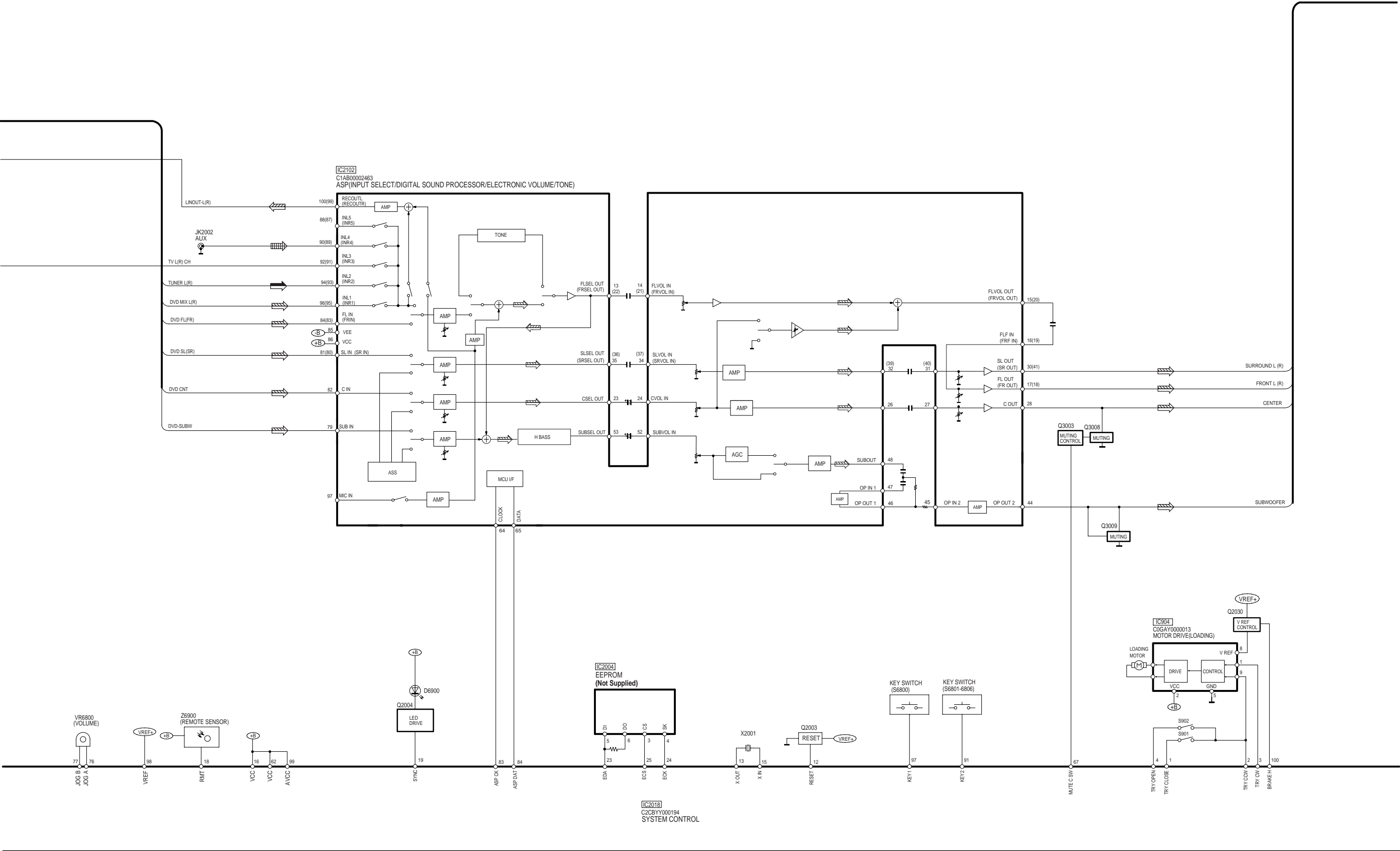

SA-HT340E/EB/EG BLOCK DIAGRAM

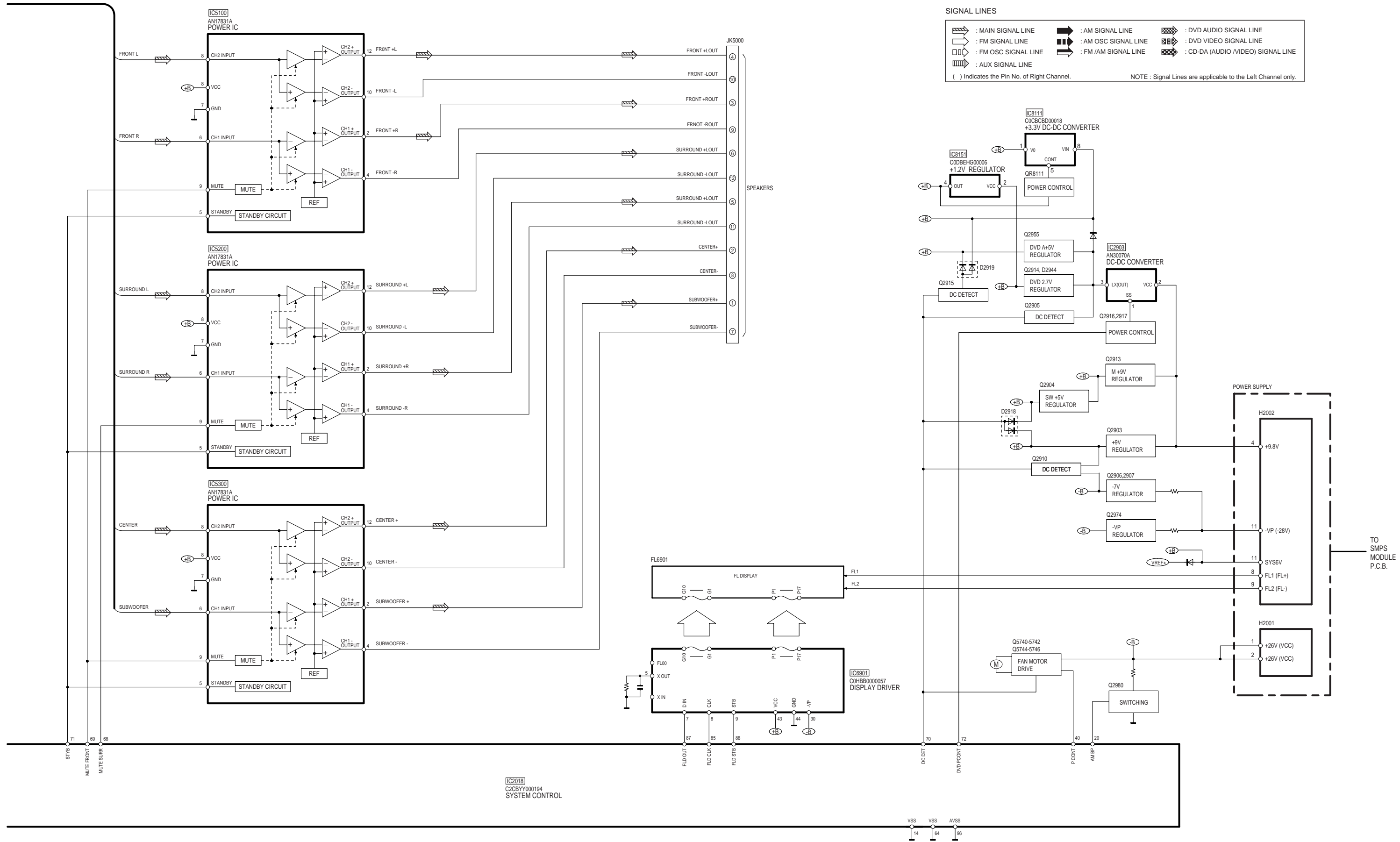

SA-HT340E/EB/EG BLOCK DIAGRAM

18 Schematic Notes

- This schematic diagram may be modified at any time with the development of new technology.

Notes:

S901:	Play detection switch.
S902:	Open detection switch.
S6800:	Tray open / close switch (▲ Open / Close).
S6804:	F. skip, search and Tuning switch (►► / ►► / TUNING ^).
S6805:	R. skip, search and Tuning switch (◀◀ / ◀◀ / TUNING v).
S6801:	Stop and TUNE mode /FM mode switch (■ TUNE MODE/FM MODE). /
S6802:	Play and memory switch (► Memory).
S6806:	Standby / on switch (POWER ⏻/⏻).
S6803:	Source select switch (SELECTOR).
VR6800:	VR Volume jog.

- Indicated voltage values are the standard values for the unit measured by the DC electronic circuit tester (high-impedance) with the chassis taken as standard. Therefore, there may exist some errors in the voltage values, depending on the internal impedance of the DC circuit tester.

- Important safety notice:









Components identified by ▲ mark have special characteristics important for safety.

Furthermore, special parts which have purposes of fire-retardant (resistors), high-quality sound (capacitors), low-noise (resistors), etc. are used.

When replacing any of components, be sure to use only manufacturer's specified parts shown in the parts list.

- The supply part number is described alone in the replacement parts list.

- Voltage and signal line

	: +B Signal line
	: CD-DA signal line
	: Main signal line
	: DVD (Video) signal line
	: DVD (Audio) signal line
	: FM/AM signal line
	: -B Signal line
	: AUX signal line

Caution!

IC and LSI are sensitive to static electricity.

Secondary trouble can be prevented by taking care during repair.

Cover the parts boxes made of plastics with aluminum foil.

Ground the soldering iron.

Put a conductive mat on the work table.

Do not touch the legs of IC or LSI with the fingers directly.

Special Note:

This model uses Switching Mode Power Supply (SMPS) for powering 2 providing necessary voltages. It is supplied as a module assembly unit. As such, there is no schematic drawings included in this technical document. The fuse located in the SMPS Module can be replaced using substitute compatible part.

Fuse part no.: K5D312BNA005
(Manufacturer: Littelfuse) 250V, 3.15A

19 Schematic Diagram

19.1. (A) DVD Module (DV3.2) Circuit

SCHEMATIC DIAGRAM-1
OPTICAL PICKUP UNIT CIRCUIT

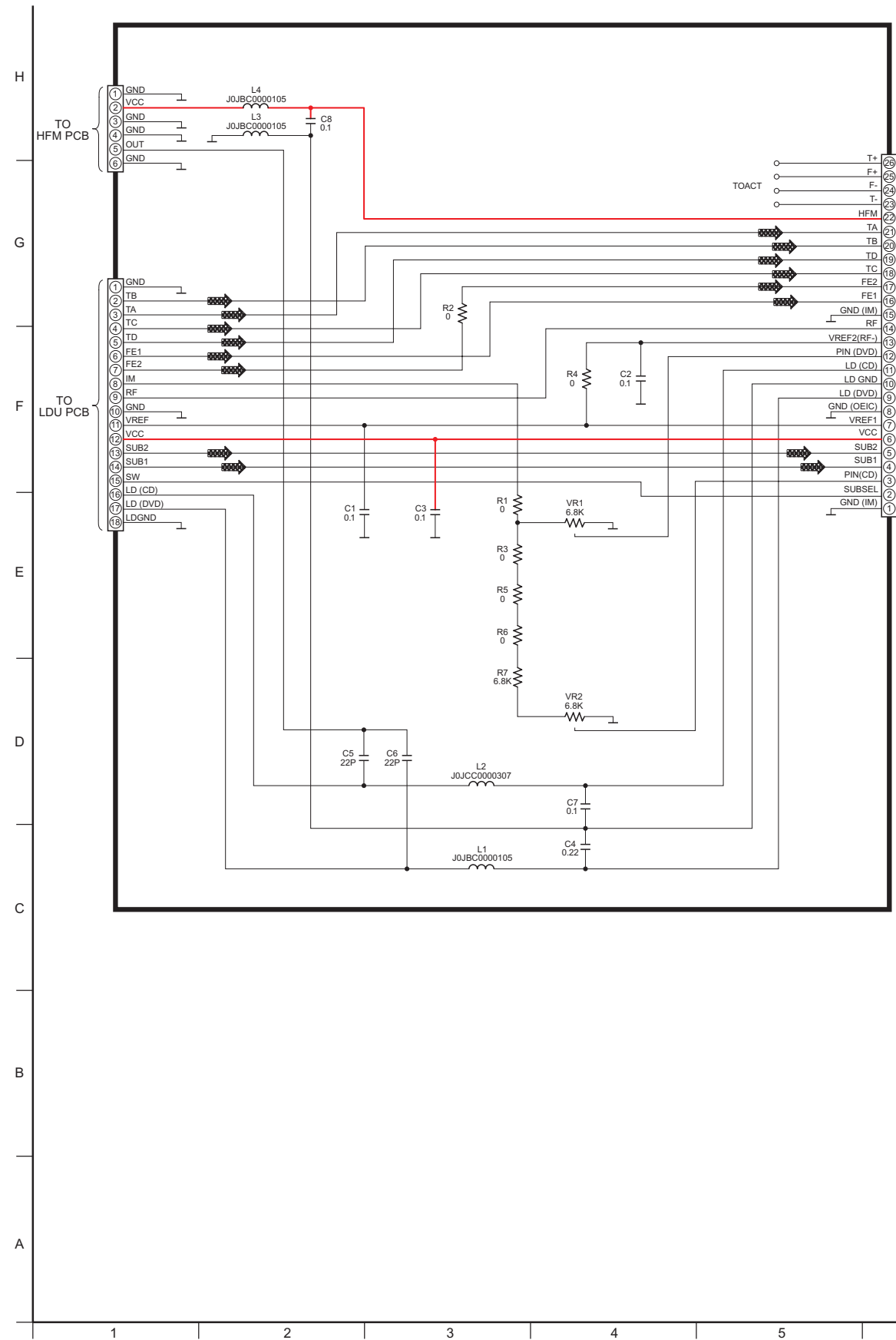

A DVD MODULE (DV3.2) CIRCUIT
: +B SIGNAL LINE
: CD-DA SIGNAL LINE

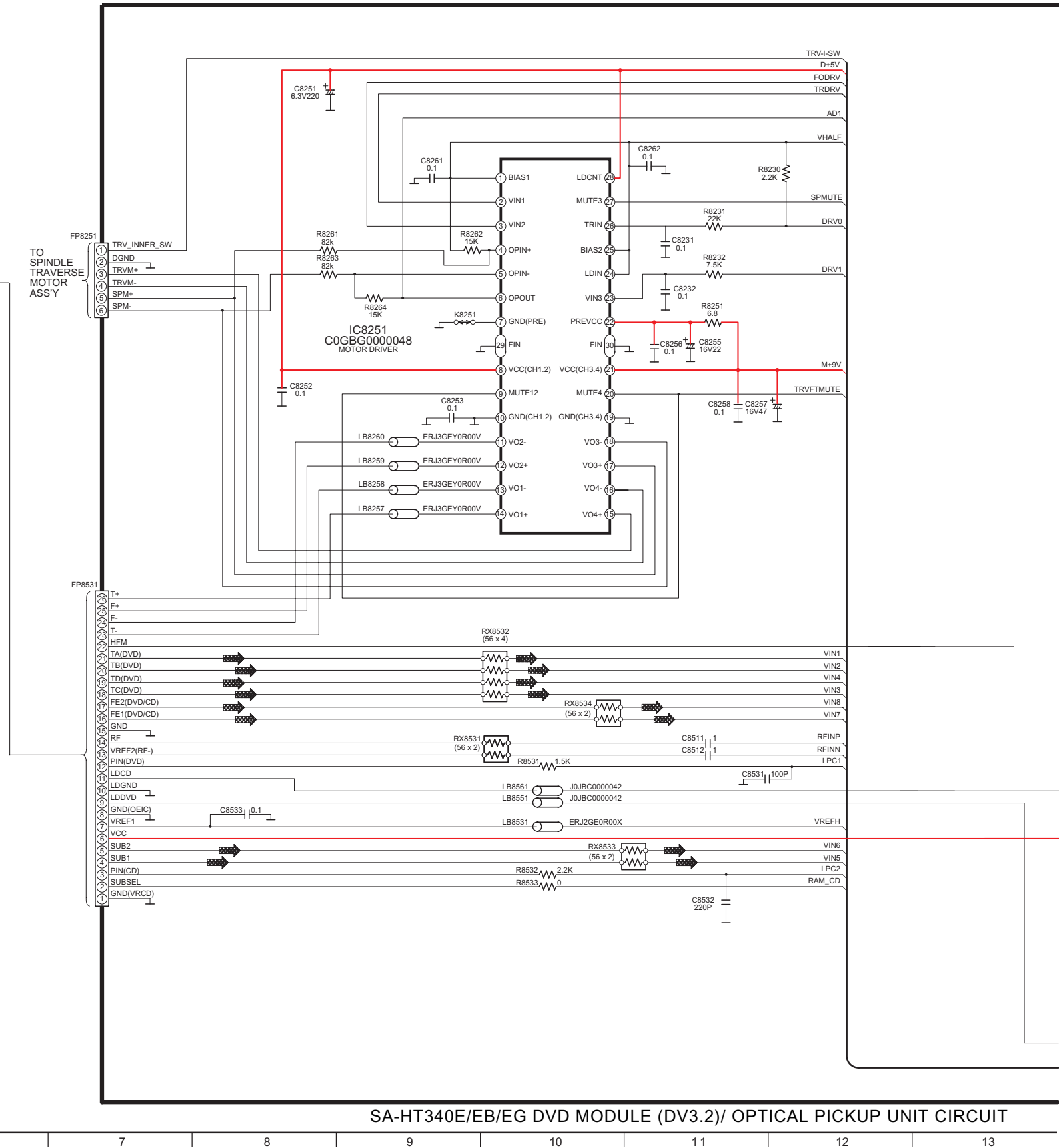

SA-HT340E/EB/EG DVD MODULE (DV3.2)/ OPTICAL PICKUP UNIT CIRCUIT

SCHEMATIC DIAGRAM-2

A DVD MODULE (DV3.2) CIRCUIT

— : +B SIGNAL LINE  : DVD VIDEO SIGNAL LINE  : MAIN SIGNAL LINE  : DVD AUDIO SIGNAL LINE

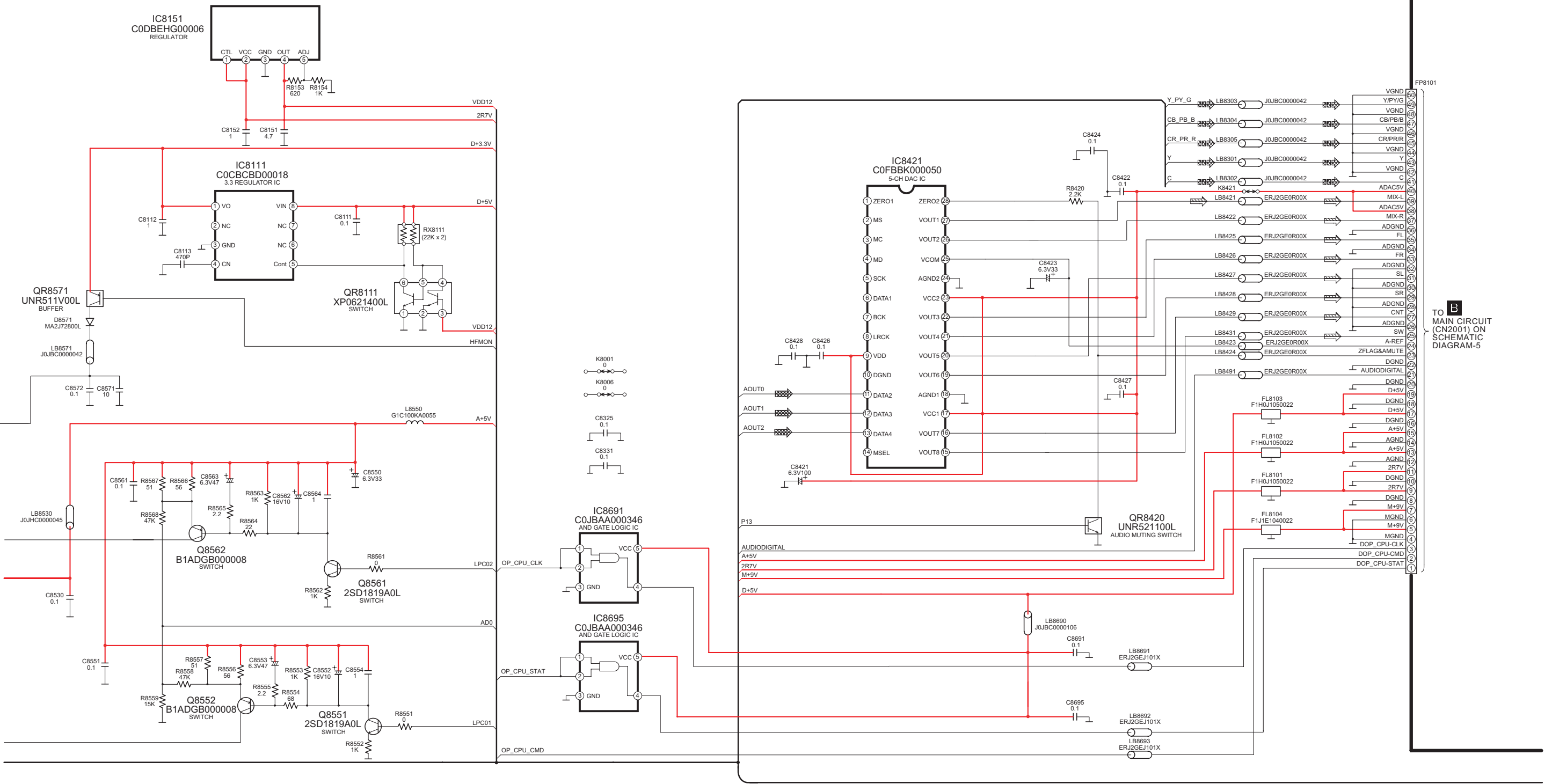

TO **B** MAIN CIRCUIT (CN2001) ON SCHEMATIC DIAGRAM-5

SA-HT340E/EB/EG DVD MODULE (DV3.2) CIRCUIT

SCHEMATIC DIAGRAM-3

A DVD MODULE (DV3.2) CIRCUIT

— : +B SIGNAL LINE

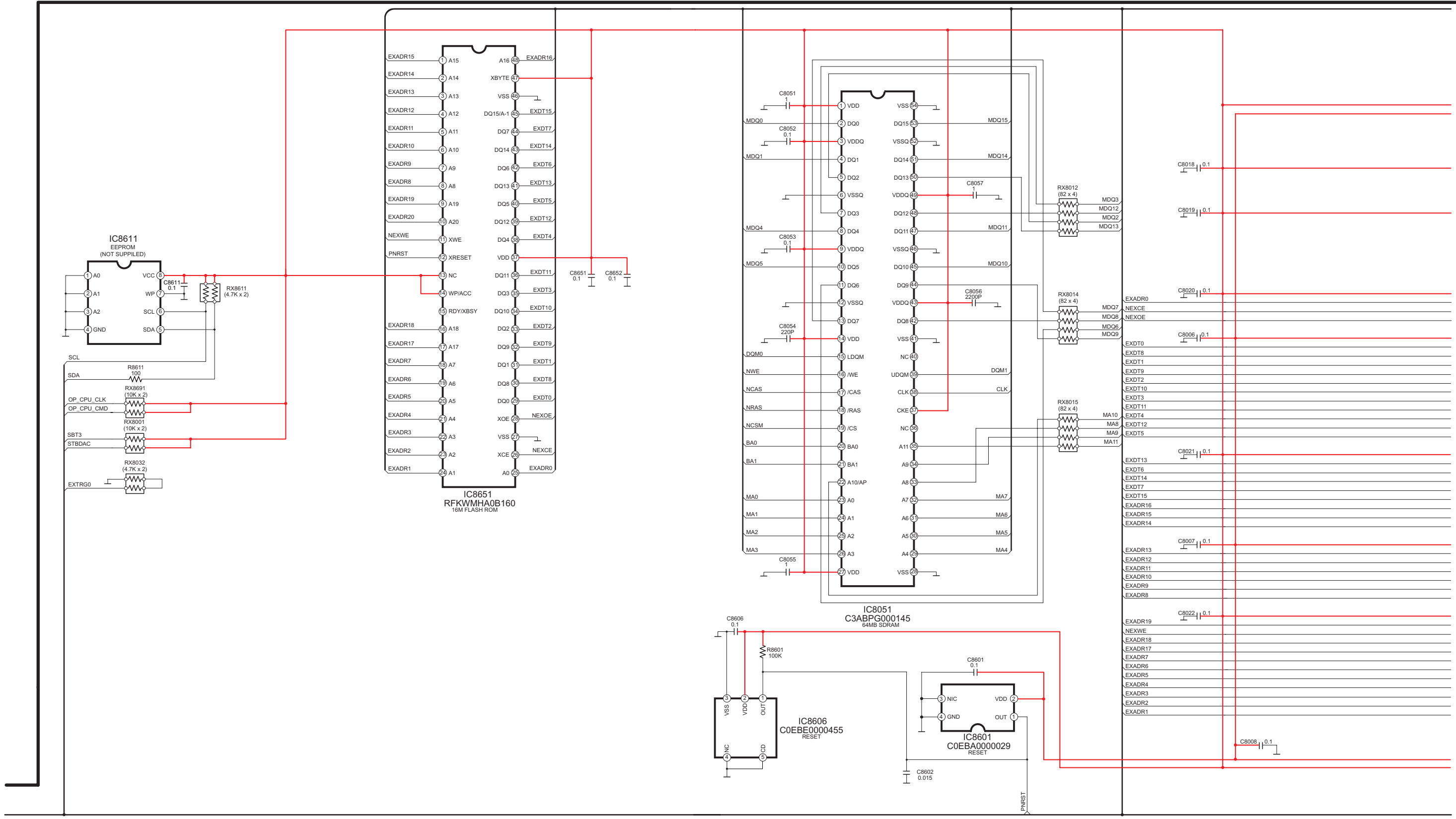

SA-HT340E/EB/EG DVD MODULE (DV3.2) CIRCUIT

SCHEMATIC DIAGRAM-4

A DVD MODULE (DV3.2) CIRCUIT

— : +B SIGNAL LINE [Symbol] : DVD AUDIO SIGNAL LINE [Symbol] : CD-DA SIGNAL LINE [Symbol] : DVD VIDEO SIGNAL LINE

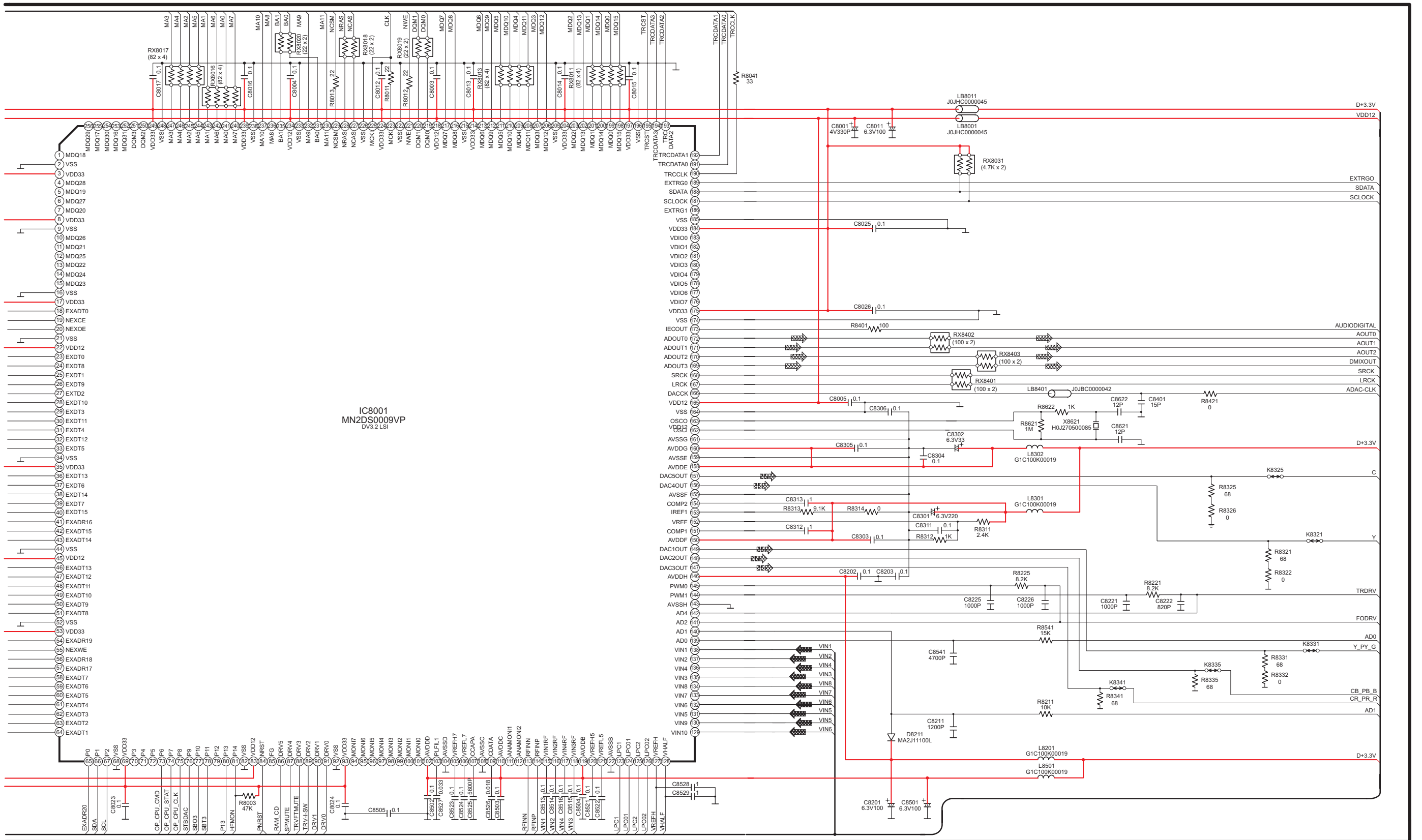

IC8001
MN2DS009VP
DV3.2 LSI

SA-HT340E/EB/EG DVD MODULE (DV3.2) CIRCUIT

SCHEMATIC DIAGRAM-6

B MAIN CIRCUIT

— :+B SIGNAL LINE

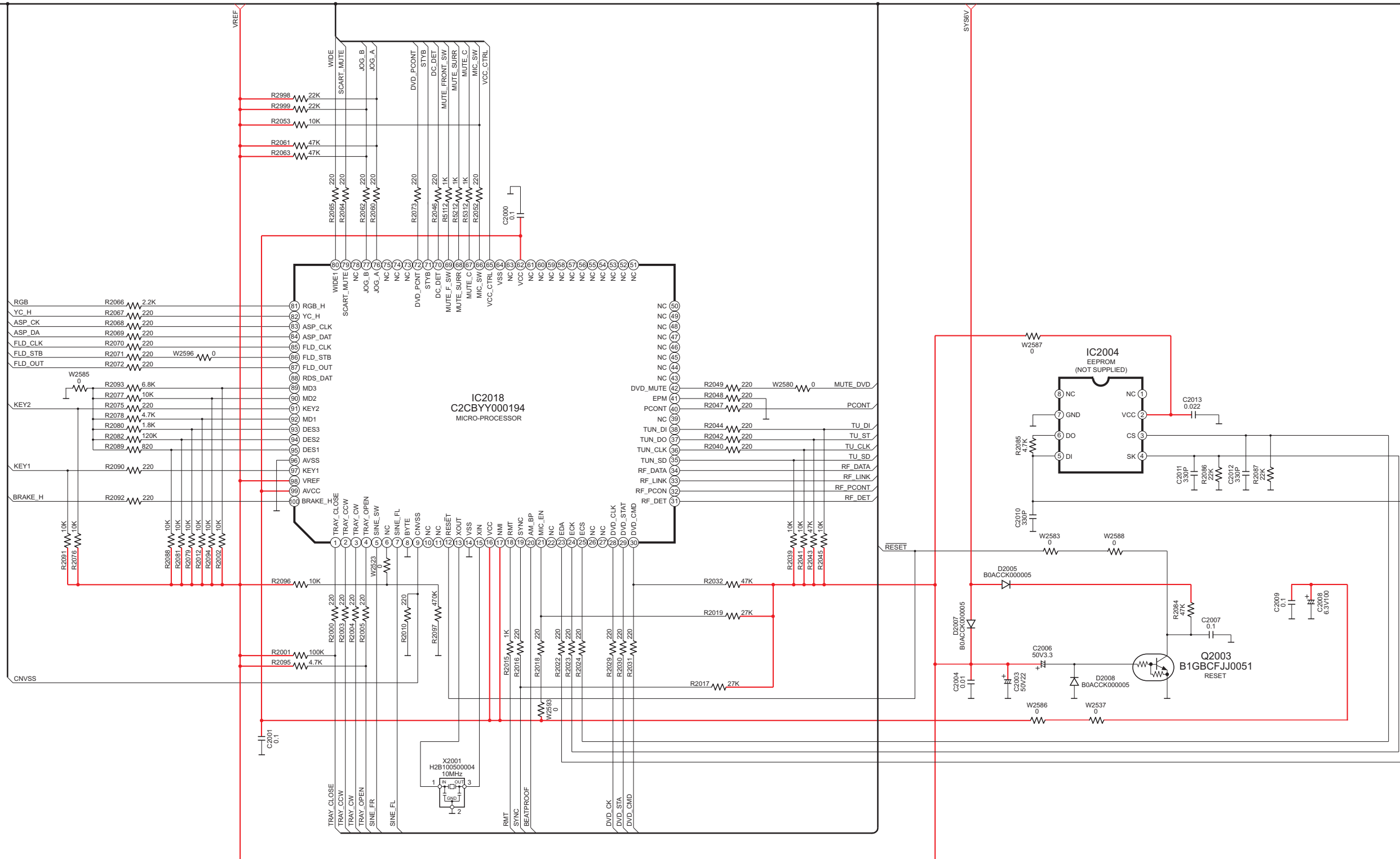

SCHEMATIC DIAGRAM-8

B MAIN CIRCUIT

— :+B SIGNAL LINE - - - :B SIGNAL LINE

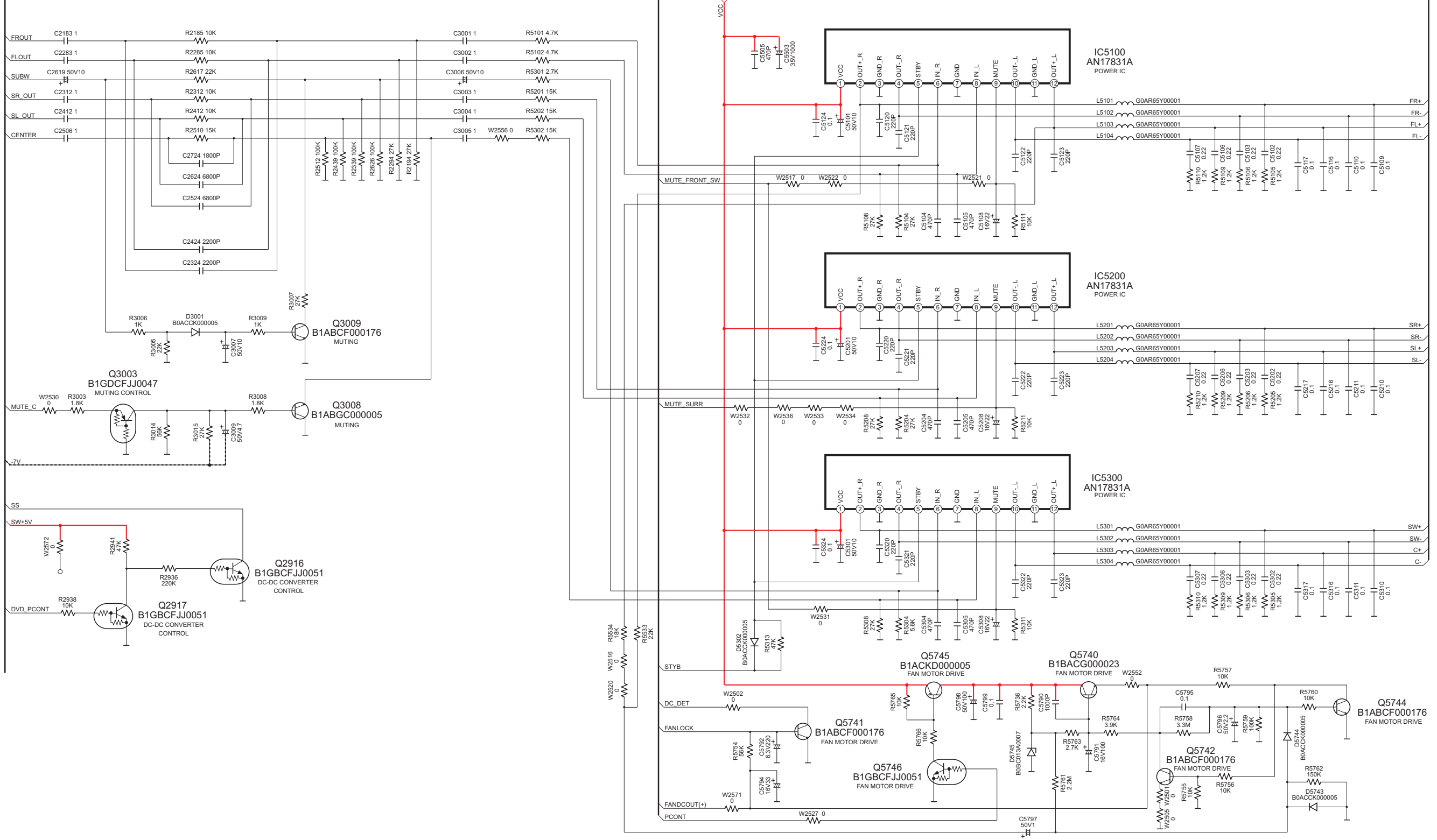

SA-HT340E/EB/EG MAIN CIRCUIT

SCHEMATIC DIAGRAM-9

B MAIN CIRCUIT

— :+B SIGNAL LINE - - - :B SIGNAL LINE

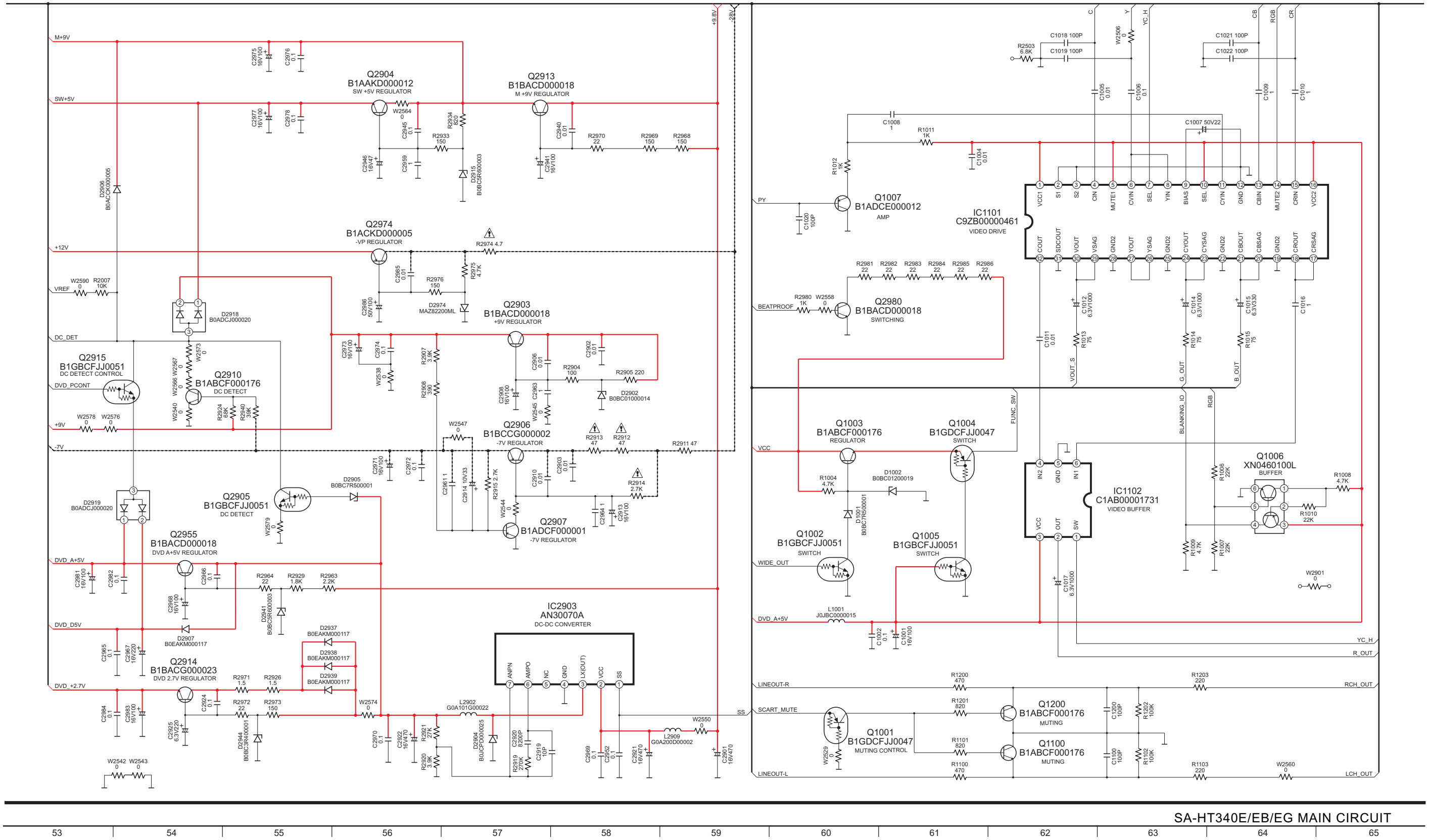

SA-HT340E/EB/EG MAIN CIRCUIT

20.2. (B) Main/Power P.C.B.

A B C D E F G H I J K L M N O P

1 2 3 4 5 6 7 8 9 **B** MAIN P.C.B. (REPX0531A)

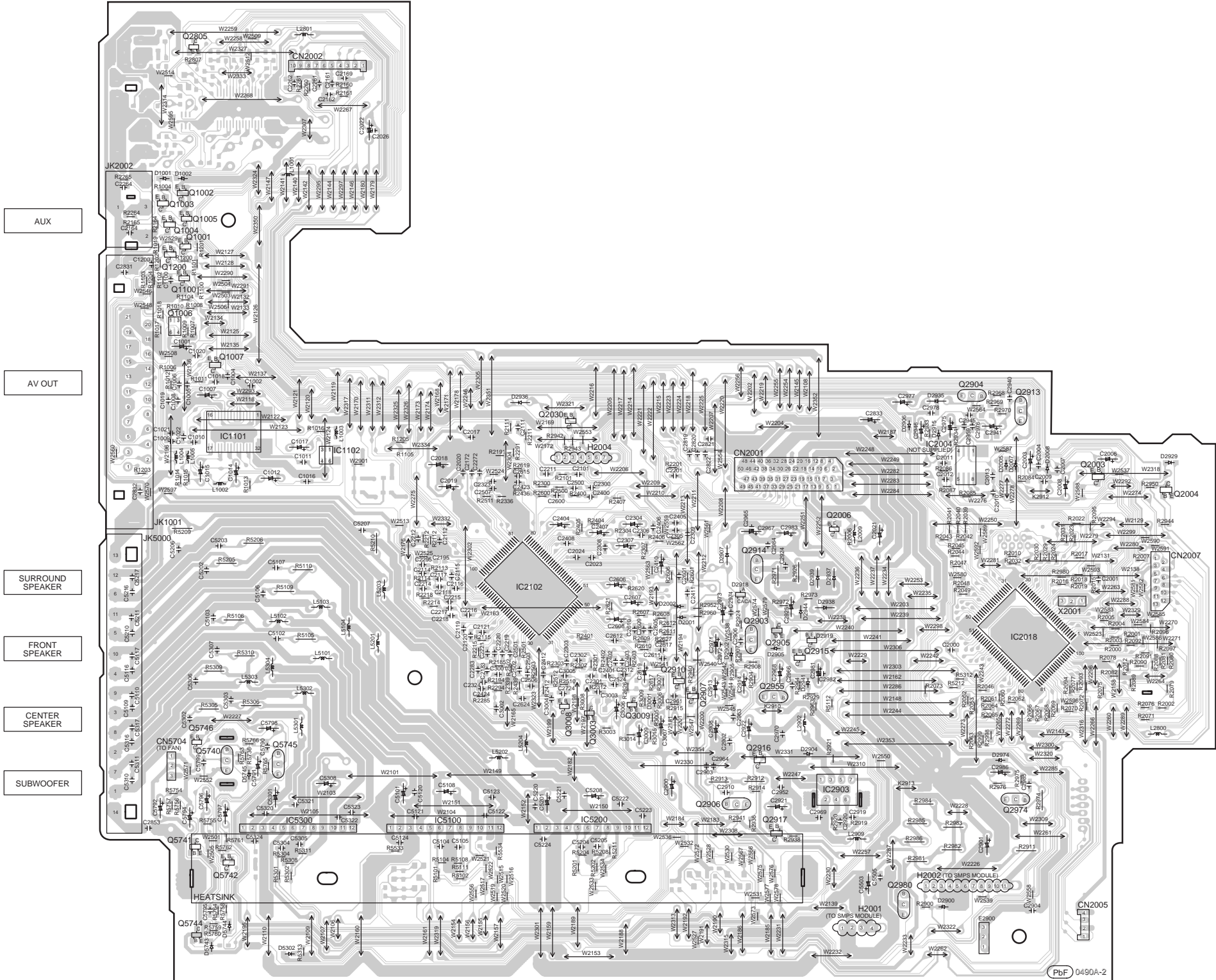

20.3. (C) FL, Volume, Tuner Extent, & Tray Loading P.C.B.

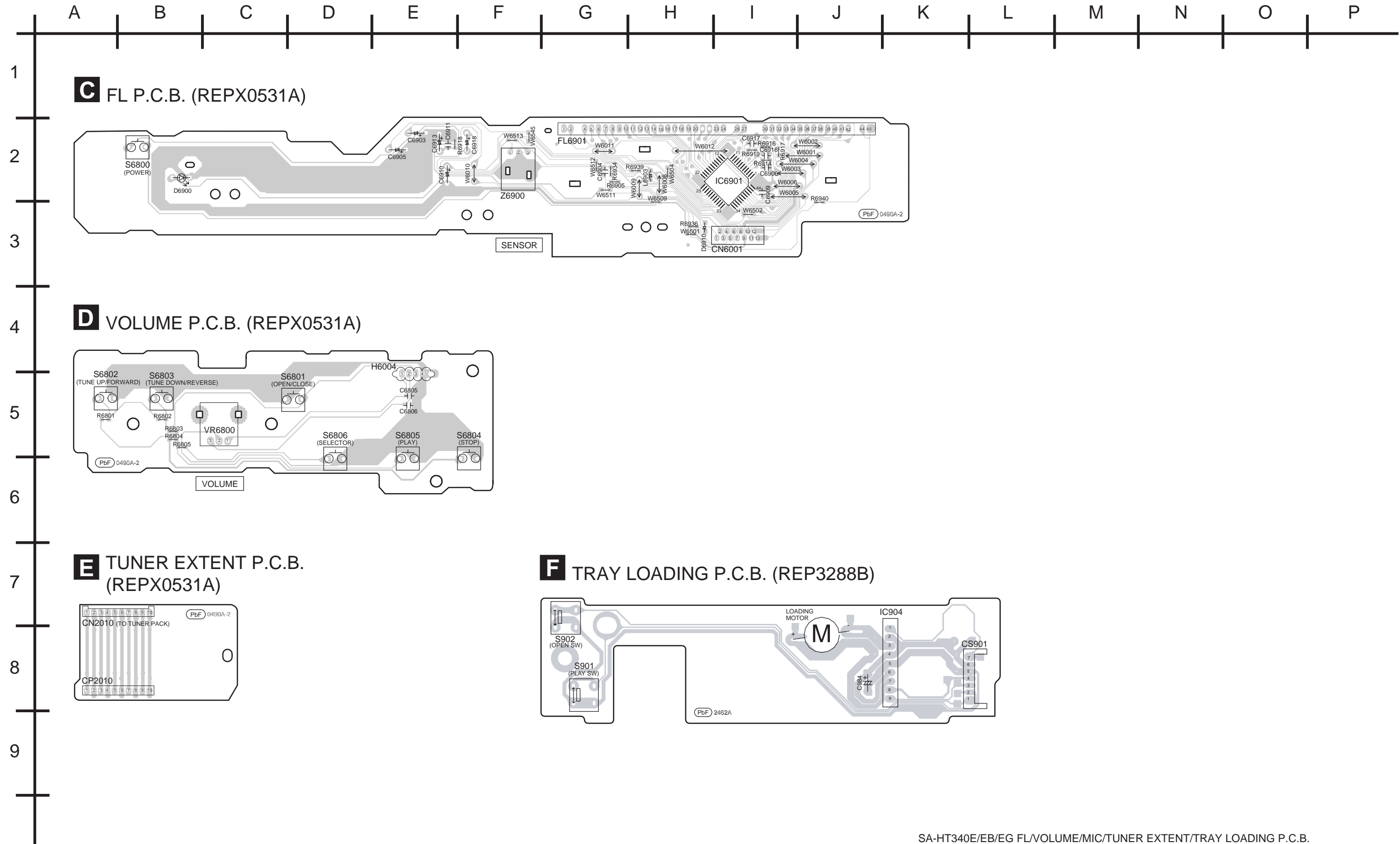

SA-HT340E/EB/EG FL/VOLUME/MIC/TUNER EXTENT/TRAY LOADING P.C.B.

21 Basic Troubleshooting Guide

21.1. Basic Troubleshooting Guide for Traverse Unit (DVD Module P.C.B.)

Problems	Checking Points	Checking components
1) Distorted picture or abnormal sound is heard during initialisation	a) Check SDRAM address, data bus, CLK and other control signals waveform	IC8051
	b) Check video signals	LB8301, R8321, R8322, LB8302, R8325, R8326
	c) Check audio DAC circuitry *Compare the above with OK condition Module	IC8421 *Check for solder short and/or component missing/damaged
2) No TOC/Long TOC	a) Check motor driver circuitry (voltages)	IC8251
	b) Check laser drive circuitry (voltages and current)	Q8550, Q8551, Q8552, Q8560, Q8561, Q8562
	c) Check LSI connection to motor drive circuitry *Compare the above with OK condition Module	IC8001 *Check for solder short and/or component missing/damaged
3) Disc not spinning	a) Check connection from Backend Module to Traverse unit	FP8201
4) Traverse not moving		
5) Traverse and spindle abnormal movement	b) Check motor driver circuitry on voltages and control signals *Compare the above with OK condition Module	IC8251 *Check for solder short and/or component damaged
6) Cannot read disc but spindle is spinning - Cannot read CD - Cannot read DVD	a) Check laser drive circuitry (voltages and current) - Check CD laser drive - Check DVD laser drive *Check voltages and LD current and compare with OK Module	Q8550, Q8551, Q8552, Q8560, Q8561, Q8562 Q8550, Q8560, Q8561, Q8562 Q8550, Q8551, Q8552, Q8560 *Check for solder short and/or component missing/damaged
7) Block noise during play	a) Check SDRAM address and data bus signal *Compare the above with OK condition Module	IC8051 *Check for solder short and/or component damaged

Problems	Checking Points	Checking components
8) Jitter out of specification	a) Check LD current b) Check OPU (change to other unit and confirm)	OPU unit (FFC connection)

21.2. Troubleshooting Guide for Power section (Power circuit)

Refer to the follow-up supplements for this model. This is due to the information not available at the time of issue for this service manual.

22 Overall Block (HT340)

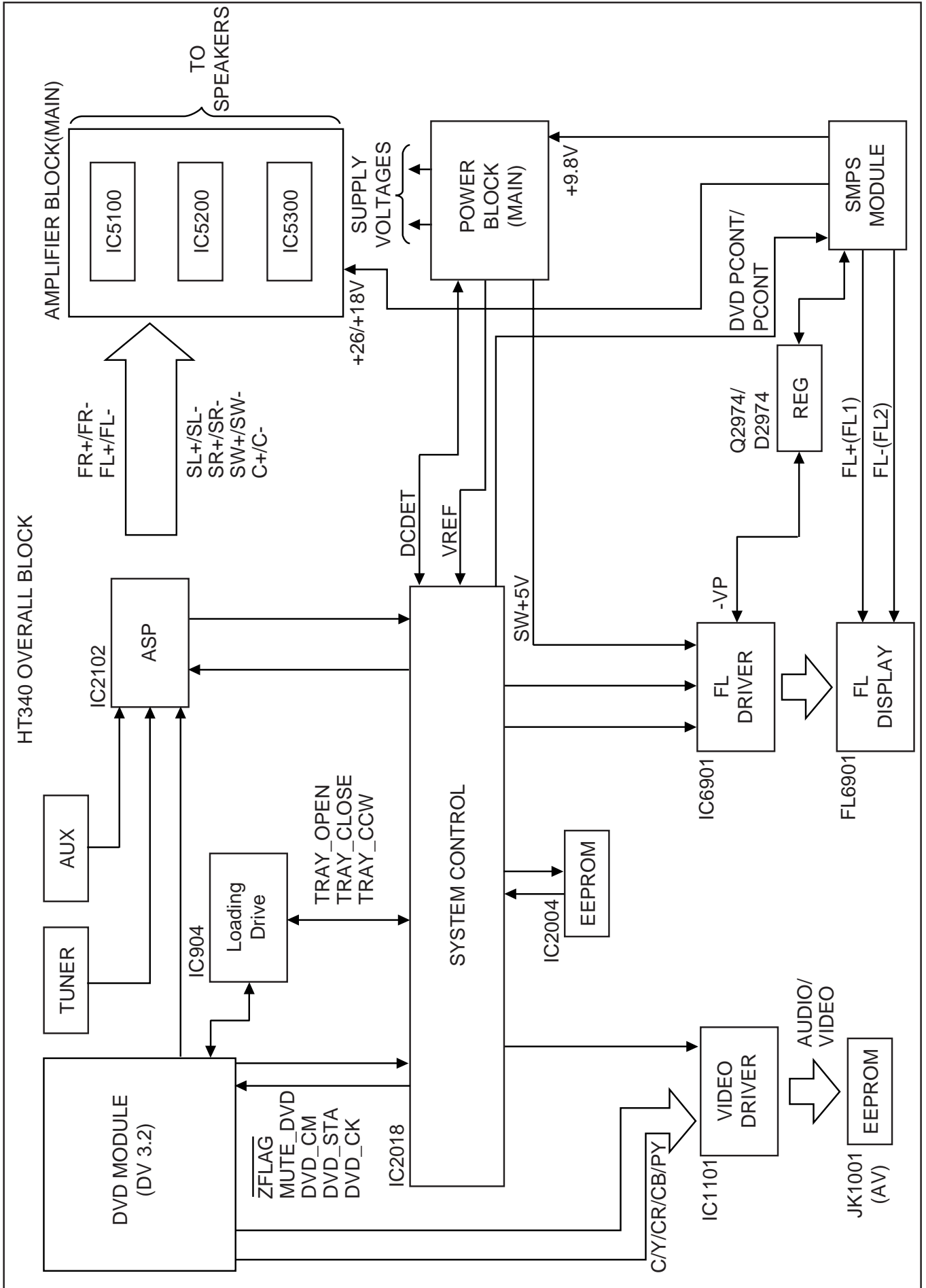

22.1. HT340 DVD Unit Block

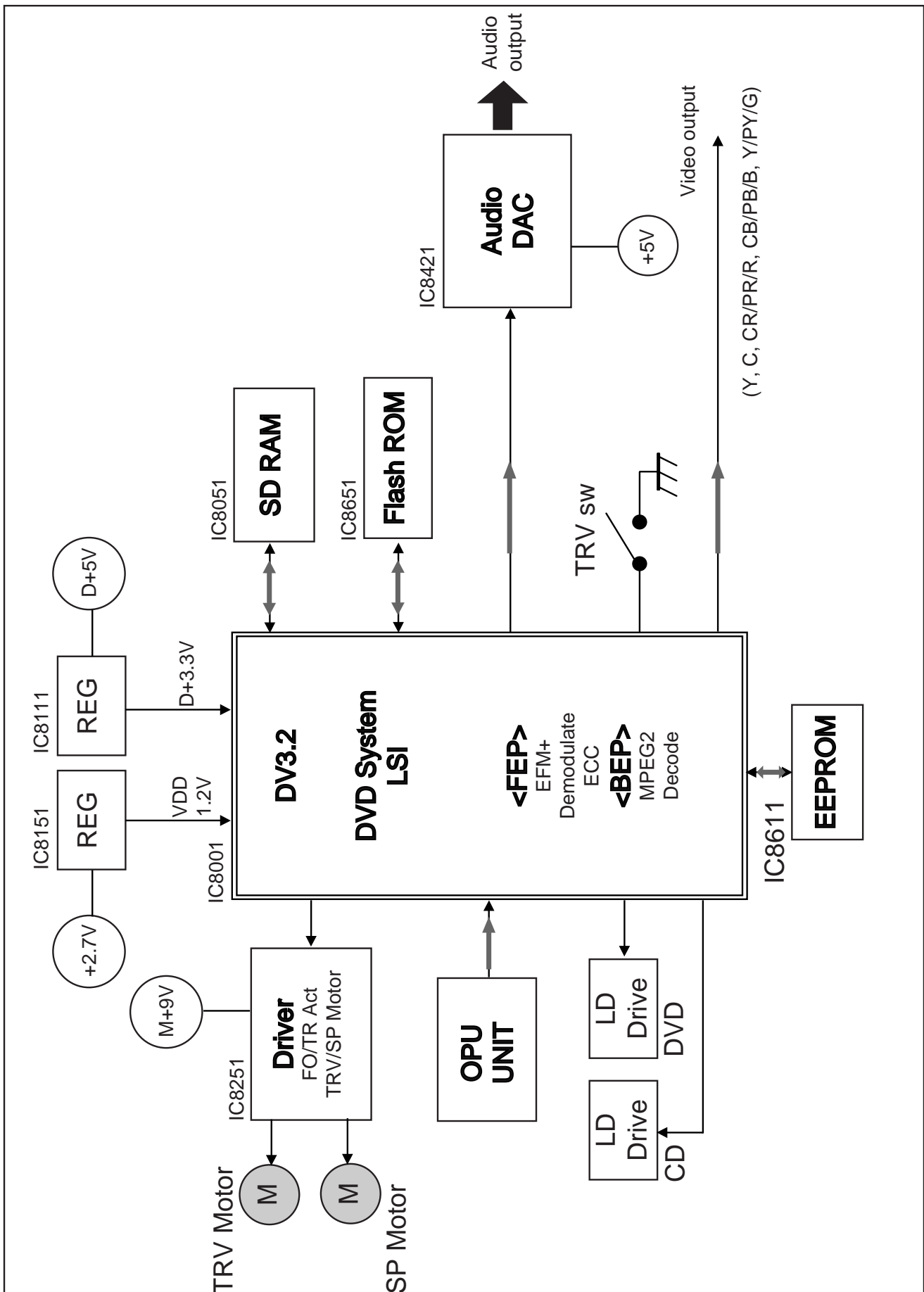

22.2. HT340 Block (Analog Signal : DVD 5.1ch Play Back Mode)

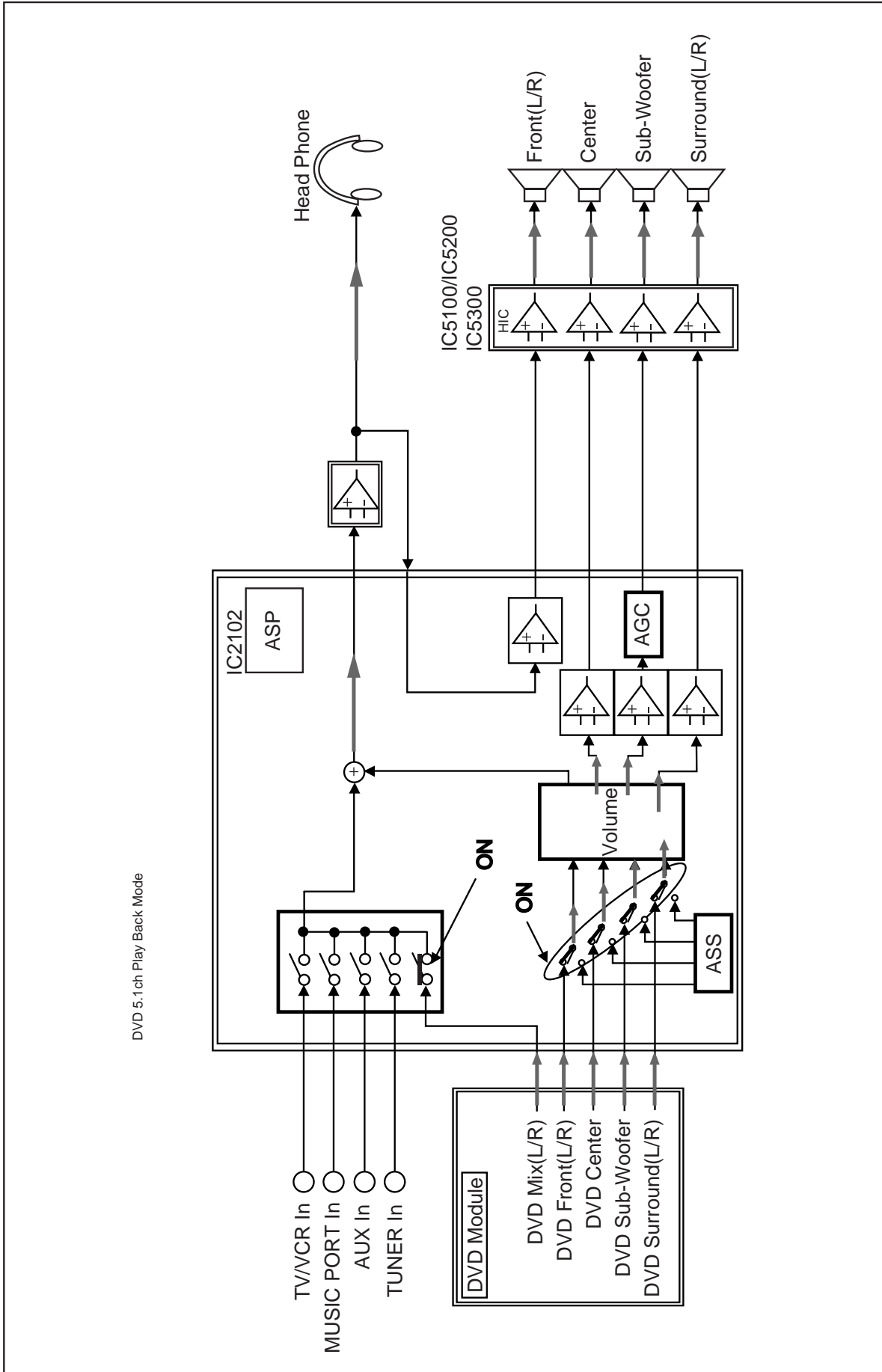

22.3. HT340 Block (Analog Signal : 2ch Analog Input Mode)

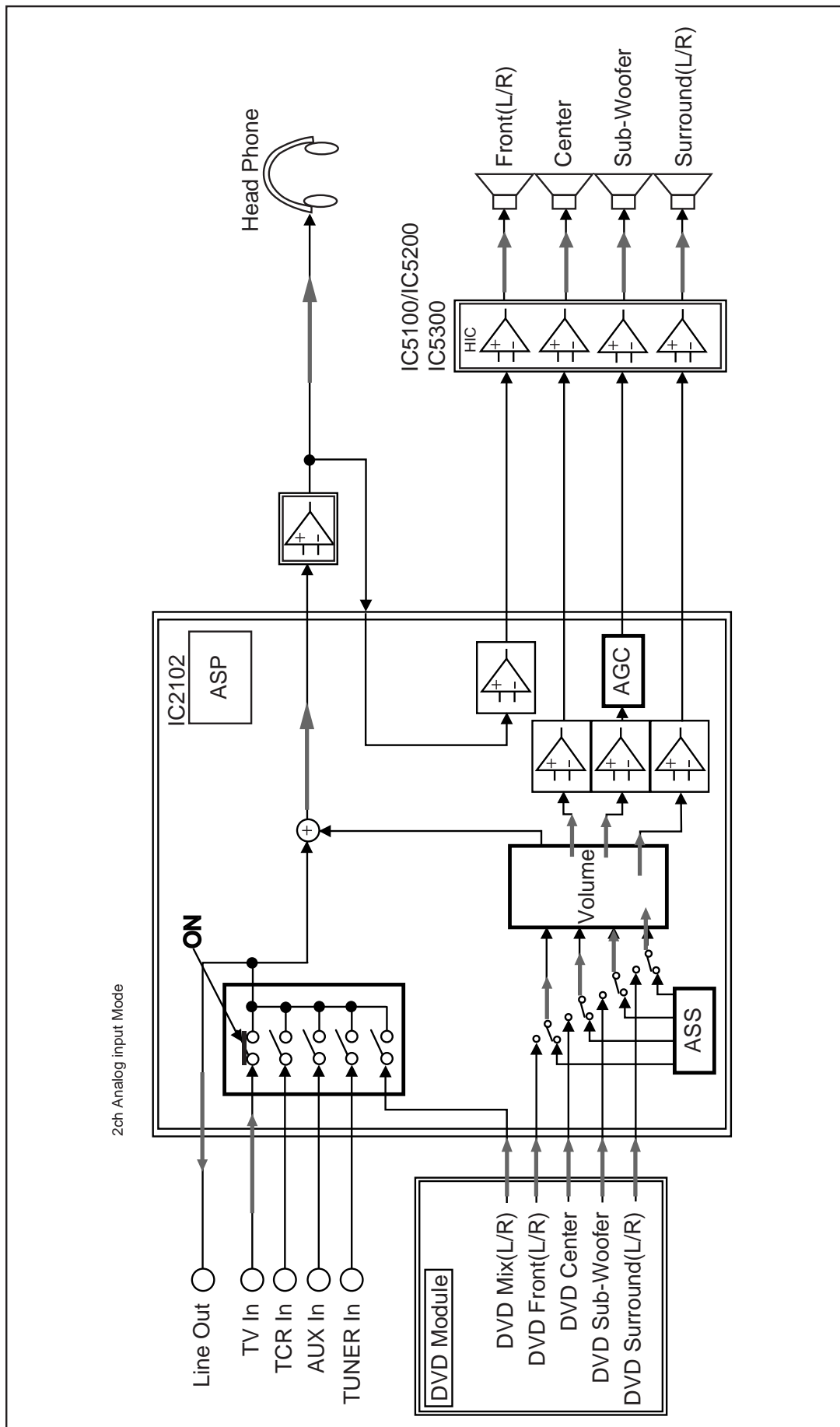

22.4. HT340 Power Supply Block

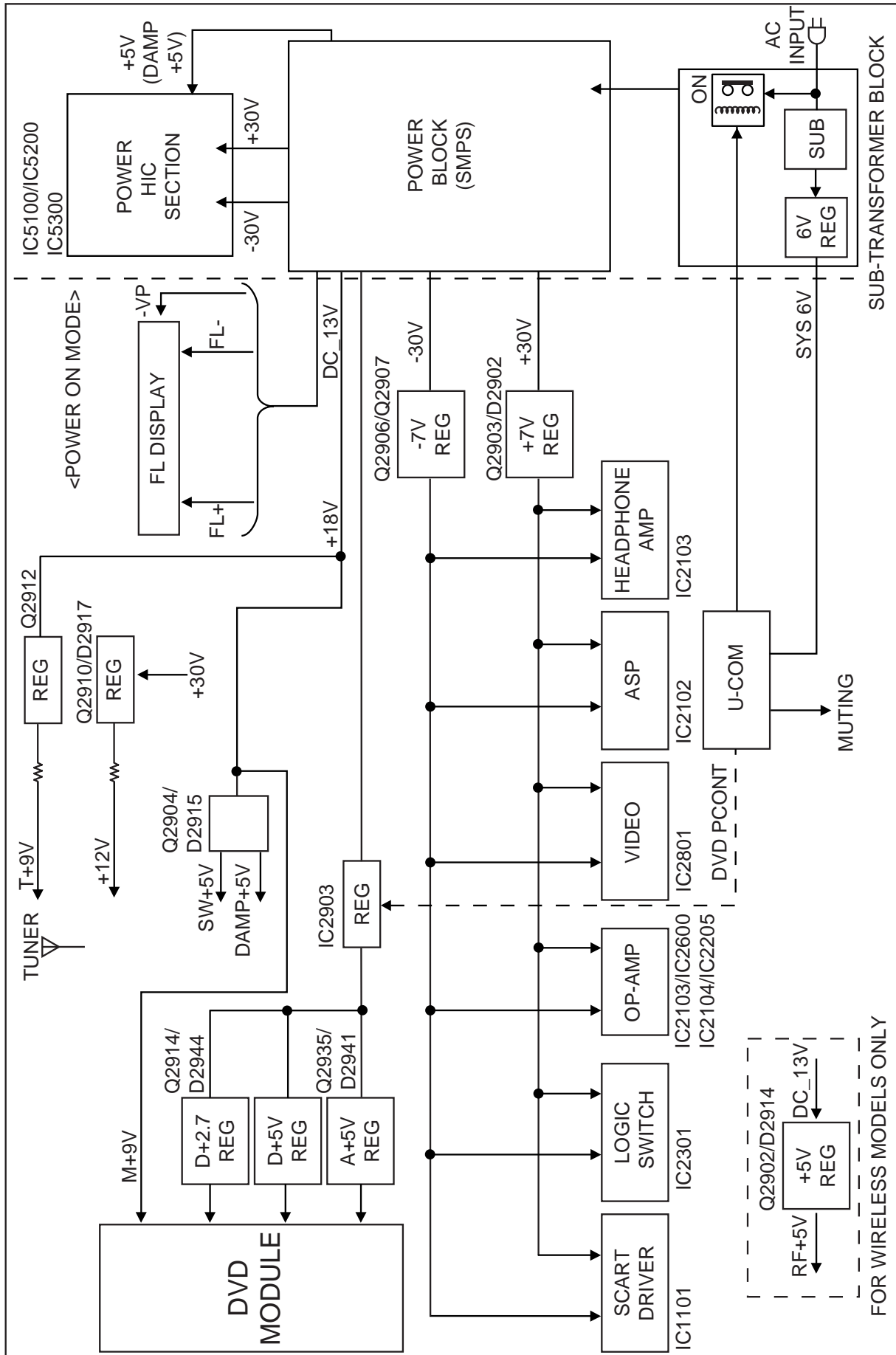

22.5. HT340 Power (Main) Block

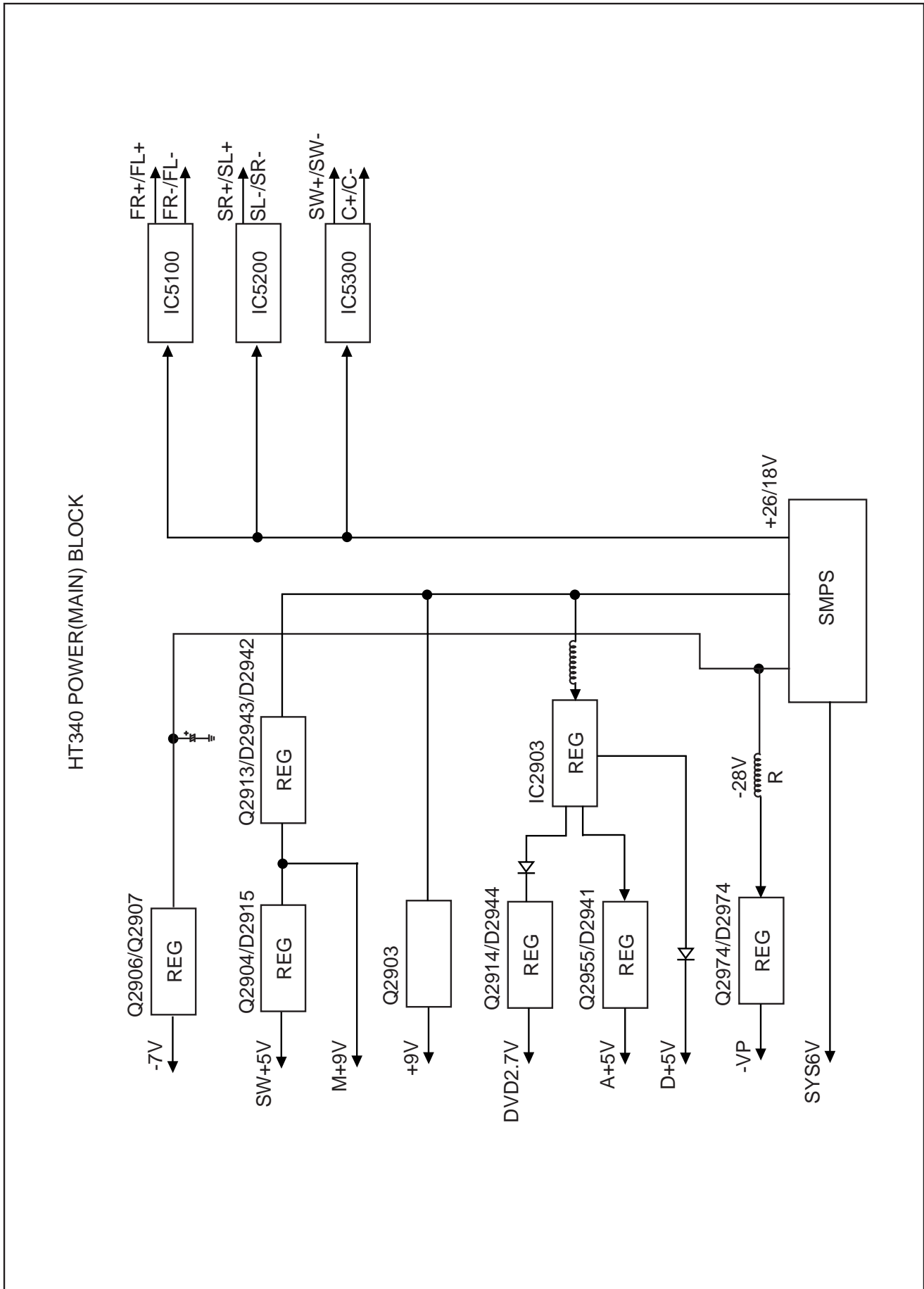

23 Terminal Function of ICs

23.1. IC2018 (C2CBYY000194): System Control Microprocessor IC

Pin No.	Terminal Name	I/O	Function
1	TRAY_CLOSE	I	Loading mechanism close SW (L: SW ON)
2	TRAY_CCW	O	Terminal for tray control 1
3	TRAY_CW	O	Terminal for tray control 2
4	TRY_OPEN	I	Loading Mechanism open SW (L: SW ON)
5	SINE_SW	I	Detect of square wave 1
6	N.C	-	No connection
7	SINE_FL	I	Detect of square wave 2
8	BYTE	-	VSS (GND)
9	CNVSS	-	VSS (GND)
10	N.C	-	No connection
11	N.C	-	No connection
12	RESET	I	System Reset Input
13	XOUT	-	Main Clock Output (10.0 MHZ)
14	VSS	-	GND (0V)
15	XIN	-	Main Clock Input (10.0 MHZ)
16	VCC	-	Power supply (5V)
17	NMI	I	Connect to VCC, External Interrupt I/P
18	RMT	I	Remote control input
19	SYNC	I	AC failure detection input
20	AM_BP	O	AM beat proof
21	MIC_EN	-	No connection
22	N.C	-	No connection
23	EDA	I/O	DATA signal for the EEPROM
24	ECK	O	CLOCK signal for the EEPROM
25	ECS	O	LAT signal for the EEPROM
26	N.C	-	No connection
27	N.C	-	No connection
28	DVD_CLK	I	CLK signal for the DVD Module
29	DVD_STAT	I	STATUS signal from DVD Module
30	DVD_CMD	O	CMD signal for the DVD Module
31	RF_DET	I	RF module detection - wireless ready
32	RF_PCON	-	RF power control
33	RF_LINK	I	RF link control - wireless ready
34	RF_DATA	O	RF change direction -wireless ready
35	TUN_SD	I	CMD signal for the DVD Module
36	TUN_CLK	O	I2C Clock Data Tuner
37	TUN_DO	I	Stereo Detection
38	TUN_DI	O	I2C Data for Tuner
39	N.C	-	No connection
40	PCONT	O	Control Signal for the Power Control Relay
41	EPM	-	Connect to Flash
42	DVD_MUTE	I	Signal from DVD module control mute circuit
43	N.C	-	No connection
44	N.C	-	No connection
45	N.C	-	No connection
46	N.C	-	No connection

Pin No.	Terminal Name	I/O	Function
47	N.C	-	No connection
48	N.C	-	No connection
49	N.C	-	No connection
50	N.C	-	No connection
51	N.C	-	No connection
52	N.C	-	No connection
53	N.C	-	No connection
54	N.C	-	No connection
55	N.C	-	No connection
56	N.C	-	No connection
57	N.C	-	No connection
58	N.C	-	No connection
59	N.C	-	No connection
60	N.C	-	No connection
61	N.C	-	No connection
62	N.C	-	No connection
63	N.C	-	No connection
64	VSS	-	GND (0V)
65	VCC_CTRL	O	Power supply control
66	MIC_SW	O	Mic surround
67	MUTE_C	O	Center mute
68	MUTE_SURR	O	Surround mute
69	MUTE_F_SW	O	Front and subwoofer mute
70	DC_DET	I	Signal from the DC Detection circuit
71	STBY	O	Digital amplifier standby control
72	DVD_PCNT	O	Control signal for the power for the DVD Module
73	N.C	-	No connection
74	N.C	-	No connection
75	N.C	-	No connection
76	JOG_A	I	Signal A from Volume JOG
77	JOG_B	I	Signal B from Volume JOG
78	N.C	-	No connection
79	SCART_MUTE	O	Line out for SCART terminal
80	WIDE1	O	Control signal for the WIDE function
81	RGB_H	O	Mute signal 1 for video output
82	YC-H	O	Control signal for the video signal Mix
83	ASP_CLK	O	ASP clock
84	ASP_DAT	O	ASP data
85	FLD_CLK	O	Clock signal for the FL driver
86	FLD_STB	O	FL driver strobe
87	FLD_OUT	O	FL data out
88	RDS_DAT	I	Data signal from the RDS decoder
89	MD3	I	Model code 3
90	MD2	I	Model code 2
91	KEY 2	I	Key 2 line input
92	MD1	I	Model code 1
93	DES3	I	Region setting for DVD
94	DES2	I	Model code Digit 1
95	DES1	I	Region setting for Tuner
96	AVSS	-	Analog power supply input
97	KEY1	I	Key 1 line input
98	VREF	-	Reference voltage input
99	AVCC	-	Analog power supply input
100	BRAKE_H	O	Terminal for tray control 3

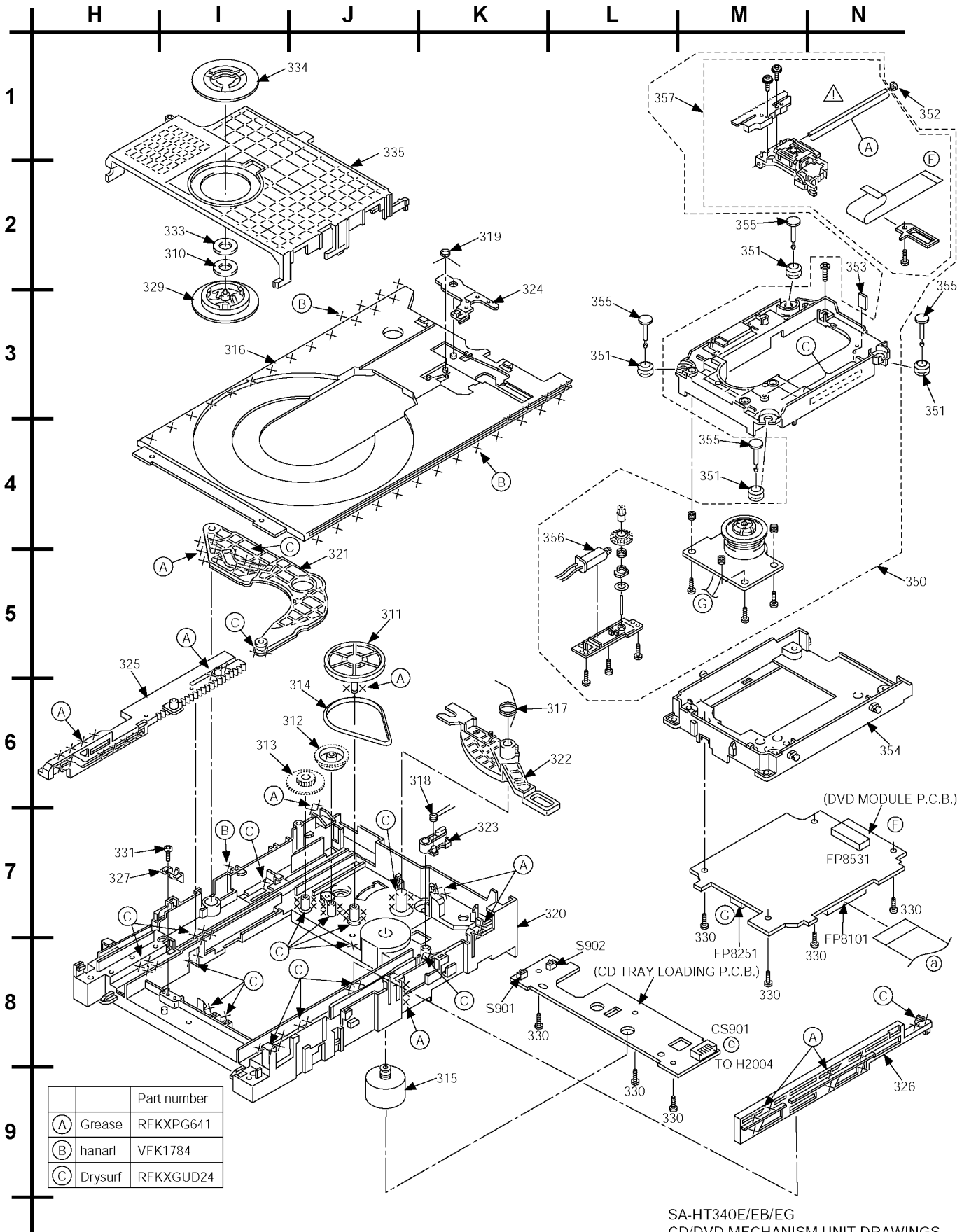

SA-HT340E/EB/EG
CD/DVD MECHANISM UNIT DRAWINGS

24.2. Packaging

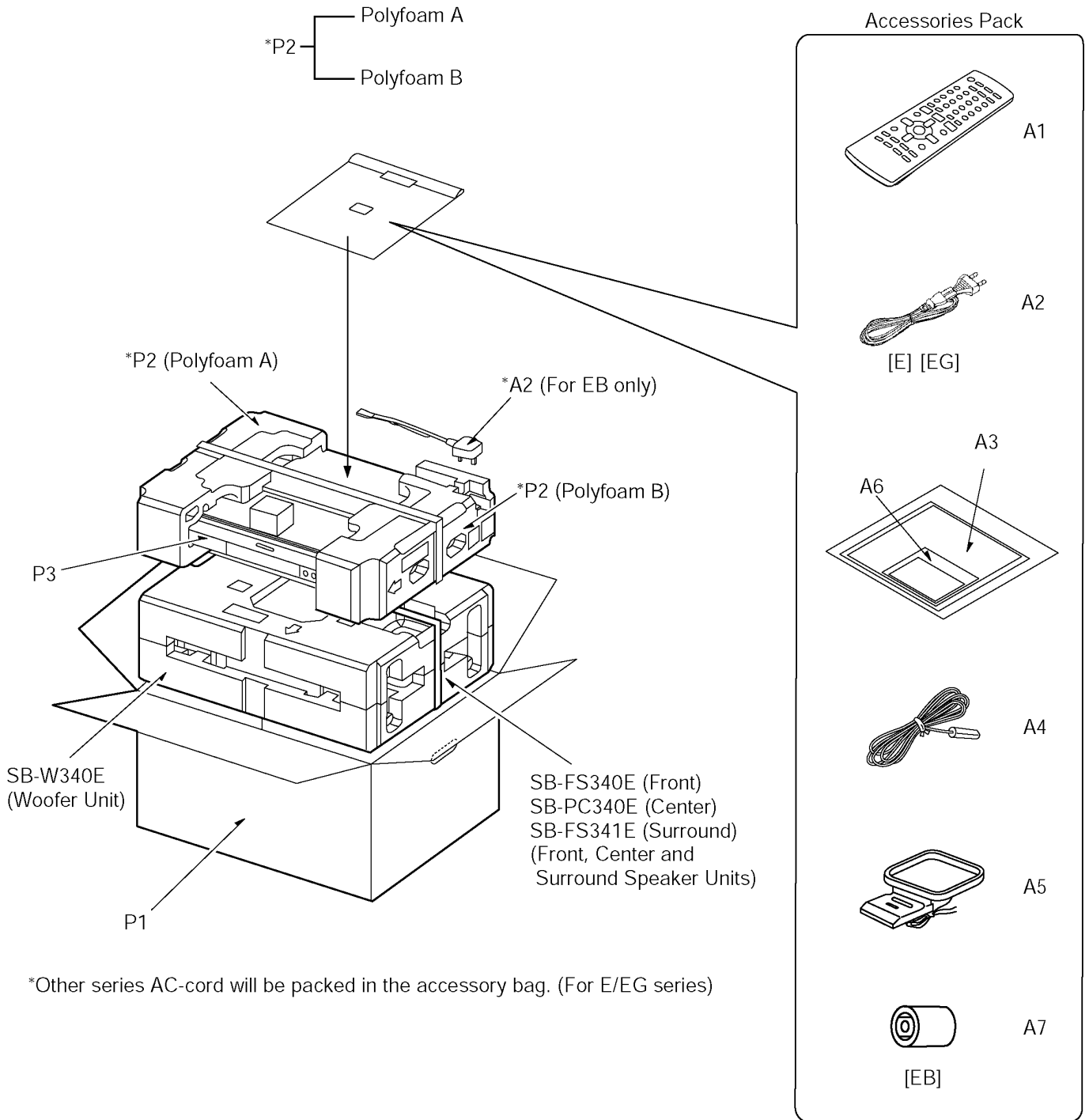

25 Replacement Parts List

Notes:

*Important safety notice:

Components identified by \triangle mark have special characteristics important for safety purpose.

Furthermore, special parts which have purposes of fire-retardant (resistors), high-quality sound (capacitors), low-noise (resistors), etc. are used.

When replacing any of components, be sure to use only manufacture's specified parts shown in the parts list.

*Warning: This product uses a laser diode. Refer to caution statements.

*Capacity values are in microfarads (μ F) unless specified otherwise, P=Pico-farads (pF), F=Farads (F).

*Resistance values are in ohms, unless specified otherwise, 1K=1,000 (OHM), 1M=1,000K (OHM).

*The parenthesized indications in the Remarks columns specify the model names and areas. (Refer to the cover page)

*The marking (RTL) indicates the retention time is limited for this item. After the discontinuation of this assembly in production, it will no longer be available.

*Reference for O/I book languages are as follows:

[En: English, Ge: German, It: Italian, Fr: French, Du: Netherlandic, Da:Danish, Sw: Swedish, Sp: Spanish, Po: Polish, Cz: Czech]

*[M] indicates in the Remarks columns indicates parts supplied by PAVCSG.

*[SPG] indicates in the Remarks columns indicates parts supplied by SPG [PAVC].

Note:

The SMPS Module P.C.B. is replaced as a unit if upon confirmation that it is not working in proper condition.

Check for all voltages for confirmation. (Refer to section 14.4) Replace fuse as specified if found broken. (Substitute Fuse Part No. K5D312BNA005)

25.1. Component Parts List

Ref. No.	Part No.	Part Name & Description	Remarks
		CABINET AND CHASSIS	
1	J3CCBC000012	TUNER PACK	[M]
2	L6FAJCCH0007	FAN MOTOR	[M]
3	REEX0612	13P FFC CABLE	[M]
4	REEX0613	50P FFC CABLE	[M]
5	REXX0384	7P FLAT WIRE (DVD)	[M]
6	REXX0519	4P FLAT WIRE (VOL)	[M]
7	REXX0520	11P FLAT WIRE	[M]
8	REXX0521	4P FLAT WIRE	[M]
9	RGB0164-S	PANA BADGE	[M]
10	RGKX0325-S	DVD LID	[M]
11	RGLX0128-Q	LIGHTING CHIP	[M]
12	RGPX0208-S	FRONT PANEL	[M]
13	RGRX0058A-A1	REAR PANEL	[M] EG/E
13	RGRX0058A-B1	REAR PANEL	[M] EB
14	RGUX0665-S	POWER BUTTON	[M]
15	RGUX0666-S	FUNCTION BUTTON	[M]
16	RGUX0676-S	OPEN CLOSE BUTTON	[M]
17	RGWX0076-S	VOLUME KNOB	[M]
18	RHD26046	SCREW	[M]
19	RHD30007-1SJ	SCREW	[M]
20	RHD30070	EARTH TERMINAL	[M]
21	RHD30102-1	SCREW	[M]
22	RHD30111-3	SCREW	[M]
23	RHD30119-S	SCREW	[M]
24	RKA0059-K	LEG RUBBER	[M]
25	RKMX0107-1S2	TOP CABINET	[M]
26	RKWX0258A-K	FL WINDOW	[M]
27	RMAX0071-1	MECHA SUPPORT	[M]
28	RMAX0086	PANEL ANGLE	[M]
29	RMKX0117	BOTTOM CHASSIS	[M]
30	RMNX0149	FL HOLDER	[M]
31	RMYX0164	SMALL HEATSINK	[M]
32	RMZX0029	MAIN PCB INSULATOR	[M]
33	RXXX0076	HEATSINK UNIT	[M]
35	XTB3+8JFJ	SCREW	[M]
		TRAVERSE DECK	
310	RHM0003-J	MAGNET	[M]
311	RDG0547	PULLEY GEAR	[M]
312	RDG0548-1	RELAY GEAR	[M]
313	RDG0549	DRIVE GEAR	[M]
314	RDV0070	BELT	[M]
315	REM0102	MOTOR UNIT	[M]
316	RGQ0395-K1	TRAY	[M]
317	RME0350	CHANGE LEVER SPRING	[M]
318	RME0351	LOCK LEVER SPRING	[M]
319	RME0353	TRAY SLIDER SPRING	[M]
320	RMK0591	MECHA CHASSIS	[M]
321	RML0627-2	DRIVE ARM	[M]
322	RML0628	CHANGE LEVER	[M]
323	RML0629	LOCK LEVER	[M]
324	RML0631	TRAY SLIDER	[M]
325	RMM0247	DRIVE RACK	[M]
326	RMM0248	SUB RACK	[M]
327	RMC0387	SUPPORT SPRING	[M]
329	RMR1446-X	CLAMPER	[M]
330	XTN26+6GFJ	SCREW	[M]
331	XTV2+6GFJ	ADDITIONAL SCREWS	[M]
333	XWG6FFY	WASHER	[M]
334	RMR1447-X	MAGNET HOLDER	[M]
335	RMR1468-K	CLAMP PLATE	[M]
350	RAE2018W-S	DT69U3 BLOCK	[M]
351	RMG0598-A	FLOATING RUBBER	[M]
352	RMG0617-H	CUSHION RUBBER A	[M]
353	RMG0618-H	CUSHION RUBBER B	[M]
354	RMR1596-X2	MIDDLE CHASSIS	[M]
355	RMS0789	FIXED PIN	[M]
356	RXQ0946	TRAVERSE MOTOR ASS'Y	[M]

Ref. No.	Part No.	Part Name & Description	Remarks
357	RXQ1389	DVD OPU SUB ASS'Y	[M]
		PRINTED CIRCUIT BOARDS	
	REP4012B	DVD MODULE P.C.B.	[M] (RTL)
	REPX0531A	MAIN P.C.B.	[M] (RTL)
	REPX0531A	VOLUME P.C.B.	[M] (RTL)
	REPX0531A	FL P.C.B.	[M] (RTL)
	REPX0531A	TOP BUTTON P.C.B.	[M] (RTL)
	REPX0531A	TUNER EXTENT P.C.B.	[M] (RTL)
	REP3288B	LOADING P.C.B.	[M] (RTL)
	NOAZ6GE00003	SWTCHING MODE POWER SUPPLY	[M] (RTL)
		INTEGRATED CIRCUITS	
IC904	COGAY0000013	IC MOTOR DRIVER	[M]
IC1101	C9ZB00000461	IC VIDEO BUFFER	[M]
IC1102	CIAB00001731	IC VIDEO BUFFER	[M]
IC2018	C2CBYY000194	IC MICRO-PROCESSOR	[M]
IC2102	CIAB00002463	IC ASP	[M]
IC2903	AN30070A	IC DC-DC CONVERTER	[M]
IC5100	AN17831A	IC POWER	[M]
IC5200	AN17831A	IC POWER	[M]
IC5300	AN17831A	IC POWER	[M]
IC6901	COHBB0000057	IC DISPLAY DRIVER	[M]
IC8001	MN2DS0009VP	IC DV3.2 LSI	[M]
IC8051	C3ABPG000145	IC SDRAM	[M]
IC8111	C0CBCBD00018	IC 3.3V REGULATOR	[M]
IC8151	C0DBEHG00006	IC 1.2V REGULATOR	[M]
IC8251	COGBG0000048	IC MOTOR DRIVER	[M]
IC8421	COFBBK000050	IC AUDIO DAC	[M]
IC8601	COEBA0000029	IC RESET	[M]
IC8606	COEBE0000455	IC RESET	[M]
IC8651	RFKWMHA0B160	IC FLASH ROM	[SPG]
IC8691	COJBAA000346	IC AND GATE	[M]
IC8695	COJBAA000346	IC AND GATE	[M]
		TRANSISTORS	
Q1001	B1GDCFJJ0047	TRANSISTOR	[M]
Q1002	B1GBCFJJ0051	TRANSISTOR	[M]
Q1003	B1ABCF000176	TRANSISTOR	[M]
Q1004	B1GDCFJJ0047	TRANSISTOR	[M]
Q1005	B1GBCFJJ0051	TRANSISTOR	[M]
Q1006	XN0460100L	TRANSISTOR	[M]
Q1007	B1ADCE000012	TRANSISTOR	[M]
Q1100	B1ABCF000176	TRANSISTOR	[M]
Q1200	B1ABCF000176	TRANSISTOR	[M]
Q2003	B1GBCFJJ0051	TRANSISTOR	[M]
Q2004	B1ADCE000012	TRANSISTOR	[M]
Q2006	B1GBCFJJ0051	TRANSISTOR	[M]
Q2030	B1GBCFJJ0051	TRANSISTOR	[M]
Q2805	B1GBCFJJ0051	TRANSISTOR	[M]
Q2903	B1BACD000018	TRANSISTOR	[M]
Q2904	B1AAKD000012	TRANSISTOR	[M]
Q2905	B1GBCFJJ0051	TRANSISTOR	[M]
Q2906	B1BCCG000002	TRANSISTOR	[M]
Q2907	B1ADCF000001	TRANSISTOR	[M]
Q2910	B1ABCF000176	TRANSISTOR	[M]
Q2913	B1BACD000018	TRANSISTOR	[M]
Q2914	B1BACG000023	TRANSISTOR	[M]
Q2915	B1GBCFJJ0051	TRANSISTOR	[M]
Q2916	B1GBCFJJ0051	TRANSISTOR	[M]
Q2917	B1GBCFJJ0051	TRANSISTOR	[M]
Q2955	B1BACD000018	TRANSISTOR	[M]
Q2974	B1ACKD000005	TRANSISTOR	[M]
Q2980	B1BACD000018	TRANSISTOR	[M]

Ref. No.	Part No.	Part Name & Description	Remarks
Q3003	B1GDCFJJ0047	TRANSISTOR	[M]
Q3008	B1ABGC000005	TRANSISTOR	[M]
Q3009	B1ABCF000176	TRANSISTOR	[M]
Q5740	B1BACG000023	TRANSISTOR	[M]
Q5741	B1ABCF000176	TRANSISTOR	[M]
Q5742	B1ABCF000176	TRANSISTOR	[M]
Q5744	B1ABCF000176	TRANSISTOR	[M]
Q5745	B1ACKD000005	TRANSISTOR	[M]
Q5746	B1GBCFJJ0051	TRANSISTOR	[M]
Q8551	2SD1819A0L	TRANSISTOR	[M]
Q8552	B1ADGB000008	TRANSISTOR	[M]
Q8561	2SD1819A0L	TRANSISTOR	[M]
Q8562	B1ADGB000008	TRANSISTOR	[M]
QR8111	XP0621400L	CHIP TRANSISTOR	[M]
QR8420	UNR521100L	CHIP TRANSISTOR	[M]
QR8571	UNR511V00L	CHIP TRANSISTOR	[M]
		DIODES	
D1001	B0BC7R500001	DIODE	[M]
D1002	B0BC01200019	DIODE	[M]
D2001	B0ACCK000005	DIODE	[M]
D2002	B0ACCK000005	DIODE	[M]
D2005	B0ACCK000005	DIODE	[M]
D2007	B0ACCK000005	DIODE	[M]
D2008	B0ACCK000005	DIODE	[M]
D2900	B0BC7R500001	DIODE	[M]
D2902	B0BC01000014	DIODE	[M]
D2904	B0JCPD000025	DIODE	[M]
D2905	B0BC7R500001	DIODE	[M]
D2906	B0ACCK000005	DIODE	[M]
D2907	B0EAKM000117	DIODE	[M]
D2915	B0BC5R600003	DIODE	[M]
D2918	B0ADCJ000020	DIODE	[M]
D2919	B0ADCJ000020	DIODE	[M]
D2929	B0ACCK000005	DIODE	[M]
D2935	B0EAKM000117	DIODE	[M]
D2936	B0EAKM000117	DIODE	[M]
D2937	B0EAKM000117	DIODE	[M]
D2938	B0EAKM000117	DIODE	[M]
D2939	B0EAKM000117	DIODE	[M]
D2941	B0BC5R600003	DIODE	[M]
D2944	B0BC3R400001	DIODE	[M]
D2974	MAZ82200ML	DIODE	[M]
D3001	B0ACCK000005	DIODE	[M]
D5302	B0ACCK000005	DIODE	[M]
D5743	B0ACCK000005	DIODE	[M]
D5744	B0ACCK000005	DIODE	[M]
D5745	B0BC013A0007	DIODE	[M]
D6900	B3AAA0000803	DIODE	[M]
D6910	B0BC5R000009	DIODE	[M]
D8211	MA2J11100L	DIODE	[M]
D8571	MA2J72800L	DIODE	[M]
		CHIP INDUCTORS	
LB8001	J0JHC0000045	CHIP INDUCTOR	[M]
LB8011	J0JHC0000045	CHIP INDUCTOR	[M]
LB8257	ERJ3GEY0R00V	CHIP RESISTOR	[M]
LB8258	ERJ3GEY0R00V	CHIP RESISTOR	[M]
LB8259	ERJ3GEY0R00V	CHIP RESISTOR	[M]
LB8260	ERJ3GEY0R00V	CHIP RESISTOR	[M]
LB8301	J0JBC0000042	CHIP INDUCTOR	[M]
LB8302	J0JBC0000042	CHIP INDUCTOR	[M]
LB8303	J0JBC0000042	CHIP INDUCTOR	[M]
LB8304	J0JBC0000042	CHIP INDUCTOR	[M]
LB8305	J0JBC0000042	CHIP INDUCTOR	[M]
LB8401	J0JBC0000042	CHIP INDUCTOR	[M]
LB8421	ERJ2GEOR00X	CHIP RESISTOR	[M]
LB8422	ERJ2GEOR00X	CHIP RESISTOR	[M]
LB8423	ERJ2GEOR00X	CHIP RESISTOR	[M]
LB8424	ERJ2GEOR00X	CHIP RESISTOR	[M]
LB8425	ERJ2GEOR00X	CHIP RESISTOR	[M]

Ref. No.	Part No.	Part Name & Description	Remarks
LB8426	ERJ2GEOR00X	CHIP RESISTOR	[M]
LB8427	ERJ2GEOR00X	CHIP RESISTOR	[M]
LB8428	ERJ2GEOR00X	CHIP RESISTOR	[M]
LB8429	ERJ2GEOR00X	CHIP RESISTOR	[M]
LB8431	ERJ2GEOR00X	CHIP RESISTOR	[M]
LB8491	ERJ2GEOR00X	CHIP RESISTOR	[M]
LB8530	J0JHC0000045	CHIP INDUCTOR	[M]
LB8531	ERJ2GEOR00X	CHIP RESISTOR	[M]
LB8551	J0JBC0000042	CHIP INDUCTOR	[M]
LB8561	J0JBC0000042	CHIP INDUCTOR	[M]
LB8571	J0JBC0000042	CHIP INDUCTOR	[M]
LB8690	J0JBC0000106	CHIP INDUCTOR	[M]
LB8691	ERJ2GEJ101X	CHIP RESISTOR	[M]
LB8692	ERJ2GEJ101X	CHIP RESISTOR	[M]
LB8693	ERJ2GEJ101X	CHIP RESISTOR	[M]
		VARIABLE RESISTORS	
VR6800	EVEKE2F2524M	VR VOLUME JOG	[M]
		SWITCHES	
S901	RSH1A044-1A	SW PLAY	[M]
S902	RSH1A044-1A	SW OPEN	[M]
S6800	EVQ21405R	SW POWER	[M]
S6801	EVQ21405R	SW OPEN/CLOSE	[M]
S6802	EVQ21405R	SW TUNE UP/FORWARD	[M]
S6803	EVQ21405R	SW TUNE DOWN/REVERSE	[M]
S6804	EVQ21405R	SW STOP	[M]
S6805	EVQ21405R	SW PLAY	[M]
S6806	EVQ21405R	SW SELECTOR	[M]
		CONNECTORS	
CN2001	K1MY50AA0029	50P CONNECTOR	[M]
CN2002	K1KA10AA0031	10P CONNECTOR	[M]
CN2005	K1KA04AA0193	4P CONNECTOR	[M]
CN2007	K1MN13AA0003	16P CONNECTOR	[M]
CN2010	K1KA10AA0031	10P CONNECTOR	[M]
CN5704	K1KA03AA0301	3P CONNECTOR	[M]
CN6001	K1MN13BA0004	13P CONNECTOR	[M]
CP2010	K1KB10B00042	10P CONNECTOR	[M]
CS901	K1KA07BA0061	7P CONNECTOR	[M]
FP8101	K1MN50BA0173	50P CONNECTOR	[M]
FP8251	K1MN06BA0148	6P CONNECTOR	[M]
FP8531	K1MY26BA0025	26P CONNECTOR	[M]
		COILS & TRANSFORMERS	
L1001	J0JBC0000015	CHIP INDUCTOR	[M]
L1002	J0JBC0000015	CHIP INDUCTOR	[M]
L1003	J0JBC0000015	CHIP INDUCTOR	[M]
L1004	J0JBC0000015	CHIP INDUCTOR	[M]
L1005	J0JBC0000015	CHIP INDUCTOR	[M]
L2009	G0C220JA0055	COIL	[M]
L2800	G0C220JA0055	COIL	[M]
L2801	G0C220JA0055	COIL	[M]
L2902	G0A101G00022	COIL	[M]
L2909	G0A200D00002	COIL	[M]
L5101	G0AR65Y00001	CHOKE COIL	[M]
L5102	G0AR65Y00001	CHOKE COIL	[M]
L5103	G0AR65Y00001	CHOKE COIL	[M]
L5104	G0AR65Y00001	CHOKE COIL	[M]
L5201	G0AR65Y00001	CHOKE COIL	[M]
L5202	G0AR65Y00001	CHOKE COIL	[M]
L5203	G0AR65Y00001	CHOKE COIL	[M]
L5204	G0AR65Y00001	CHOKE COIL	[M]
L5301	G0AR65Y00001	CHOKE COIL	[M]
L5302	G0AR65Y00001	CHOKE COIL	[M]
L5303	G0AR65Y00001	CHOKE COIL	[M]

Ref. No.	Part No.	Part Name & Description	Remarks
L5304	G0AR65Y00001	CHOKE COIL	[M]
L6903	J0JBC0000041	CHIP INDUCTOR	[M]
L8201	G1C100K00019	CHIP COIL	[M]
L8301	G1C100K00019	CHIP COIL	[M]
L8302	G1C100K00019	CHIP COIL	[M]
L8501	G1C100K00019	CHIP COIL	[M]
L8550	G1C100KA0055	CHIP INDUCTOR	[M]
		COMPONENT COMBINATION	
Z6900	B3RAB0000025	REMOTE SENSOR	[M]
		OSCILLATORS	
X2001	H2B100500004	CERAMIC RESONATORS	[M]
X8621	H0J270500085	CRYSTAL	[M]
		DISPLAY TUBE	
FL6901	A2BD00000160	FL DISPLAY	[M]
FL8101	F1H0J1050022	CHIP CAPACITOR	[M]
FL8102	F1H0J1050022	CHIP CAPACITOR	[M]
FL8103	F1H0J1050022	CHIP CAPACITOR	[M]
FL8104	F1J1E1040022	CHIP CAPACITOR	[M]
		FUSE	
F1	K5D312BNA005	FUSE	[M]
		HOLDERS	
H2001	K1YF04000001	CABLE HOLDER	[M]
H2002	K1YZ11000002	11P CABLE HOLDER	[M]
H2004	K1YZ07000001	7P WIRE HOLDER	[M]
H6004	K1YZ04000002	4P CABLE HOLDER	[M]
		JACKS	
JK1001	K1FY121B0002	JK SCART CONNECTOR	[M]
JK2002	K2HA2YYA0002	JK 2P RCA	[M]
JK5000	K4AC12B00003	JK SPEAKER	[M]
		EARTH TERMINAL	
E2900	K4CZ01000027	TERMINAL	[M]
		PACKING MATERIALS	
P1	RPGX1554	PACKING CASE	[M]EG/E
P1	RPGX1556	PACKING CASE	[M]EB
P2	RPNX0369	POLYFOAM	[M]
P3	RPFX0058-1J	MIRAMAT	[M]
		ACCESSORIES	
A1	N2QAYZ000005	REMOTE CONTROL	[M]
A1-1	RKK-HTR0051K	R/C BATTERY COVER	[M]
A2	K2CQ2CA00002	AC CORD	[M] △ EG/E
A2	K2CT3CA00004	AC CORD	[M] △ EB
A3	RQT8586-D	O/I BOOK (EN)	[M]EG
A3	RQT8587-H	O/I BOOK (SP/PO/CZ)	[M]EG
A3	RQT8588-E	O/I BOOK (GE/IT/FR)	[M]E
A3	RQT8589-B	O/I BOOK (DU/DA/SW)	[M]EB/E
A4	RSA0007-L	FM ANTENNA	[M]
A5	N1DAAA00002	AM LOOP ANTENNA	[M]
A6	RQCA0968	SPEAKER LABEL	[M]
A7	K1YZ02000013	DIN ADAPTOR	[M]EB
		RESISTORS	
R1004	ERJ3GEYJ472V	4.7K 1/16W	[M]

Ref. No.	Part No.	Part Name & Description	Remarks
R1006	ERJ3GEYJ223V	22K 1/16W	[M]
R1007	ERJ3GEYJ223V	22K 1/16W	[M]
R1008	ERJ3GEYJ472V	4.7K 1/16W	[M]
R1009	ERJ3GEYJ472V	4.7K 1/16W	[M]
R1010	ERJ3GEYJ223V	22K 1/16W	[M]
R1011	ERJ3GEYJ102V	1K 1/16W	[M]
R1012	ERJ3GEYJ102V	1K 1/16W	[M]
R1013	ERJ3GEYF750V	75 1/16W	[M]
R1014	ERJ3GEYF750V	75 1/16W	[M]
R1015	ERJ3GEYF750V	75 1/16W	[M]
R1016	ERJ3GEYF750V	75 1/16W	[M]
R1017	ERJ3GEYF750V	75 1/16W	[M]
R1018	ERJ3GEYF750V	75 1/16W	[M]
R1019	ERJ3GEYJ471V	470 1/16W	[M]
R1100	ERJ3GEYJ471V	470 1/16W	[M]
R1101	ERJ3GEYJ821V	820 1/16W	[M]
R1102	ERJ3GEYJ104V	100K 1/16W	[M]
R1103	ERJ3GEYJ221V	220 1/16W	[M]
R1104	ERJ3GEYJ103V	10K 1/16W	[M]
R1105	ERJ3GEYJ332V	3.3K 1/16W	[M]
R1200	ERJ3GEYJ471V	470 1/16W	[M]
R1201	ERJ3GEYJ821V	820 1/16W	[M]
R1202	ERJ3GEYJ104V	100K 1/16W	[M]
R1203	ERJ3GEYJ221V	220 1/16W	[M]
R1204	ERJ3GEYJ103V	10K 1/16W	[M]
R1205	ERJ3GEYJ332V	3.3K 1/16W	[M]
R2000	ERJ3GEYJ221V	220 1/16W	[M]
R2001	ERJ3GEYJ104V	100K 1/16W	[M]
R2002	ERJ3GEYJ103V	10K 1/16W	[M]
R2003	ERJ3GEYJ221V	220 1/16W	[M]
R2004	ERJ3GEYJ221V	220 1/16W	[M]
R2005	ERJ3GEYJ221V	220 1/16W	[M]
R2006	ERJ3GEYJ182V	1.8K 1/16W	[M]
R2007	ERJ3GEYJ103V	10K 1/16W	[M]
R2010	ERJ3GEYJ221V	220 1/16W	[M]
R2012	ERJ3GEYJ103V	10K 1/16W	[M]
R2015	ERJ3GEYJ102V	1K 1/16W	[M]
R2016	ERJ3GEYJ221V	220 1/16W	[M]
R2017	ERJ3GEYJ273V	27K 1/16W	[M]
R2018	ERJ3GEYJ221V	220 1/16W	[M]
R2019	ERJ3GEYJ273V	27K 1/16W	[M]
R2022	ERJ3GEYJ221V	220 1/16W	[M]
R2023	ERJ3GEYJ221V	220 1/16W	[M]
R2024	ERJ3GEYJ221V	220 1/16W	[M]
R2029	ERJ3GEYJ221V	220 1/16W	[M]
R2030	ERJ3GEYJ221V	220 1/16W	[M]
R2031	ERJ3GEYJ221V	220 1/16W	[M]
R2032	ERJ3GEYJ473V	47K 1/16W	[M]
R2039	ERJ3GEYJ103V	10K 1/16W	[M]
R2040	ERJ3GEYJ221V	220 1/16W	[M]
R2041	ERJ3GEYJ103V	10K 1/16W	[M]
R2042	ERJ3GEYJ221V	220 1/16W	[M]
R2043	ERJ3GEYJ473V	47K 1/16W	[M]
R2044	ERJ3GEYJ221V	220 1/16W	[M]
R2045	ERJ3GEYJ103V	10K 1/16W	[M]
R2046	ERJ3GEYJ221V	220 1/16W	[M]
R2047	ERJ3GEYJ221V	220 1/16W	[M]
R2048	ERJ3GEYJ221V	220 1/16W	[M]
R2049	ERJ3GEYJ221V	220 1/16W	[M]
R2052	ERJ3GEYJ221V	220 1/16W	[M]
R2053	ERJ3GEYJ103V	10K 1/16W	[M]
R2060	ERJ3GEYJ221V	220 1/16W	[M]
R2061	ERJ3GEYJ473V	47K 1/16W	[M]
R2062	ERJ3GEYJ221V	220 1/16W	[M]
R2063	ERJ3GEYJ473V	47K 1/16W	[M]
R2064	ERJ3GEYJ221V	220 1/16W	[M]
R2065	ERJ3GEYJ221V	220 1/16W	[M]
R2066	ERJ3GEYJ222V	2.2K 1/16W	[M]
R2067	ERJ3GEYJ221V	220 1/16W	[M]
R2068	ERJ3GEYJ221V	220 1/16W	[M]
R2069	ERJ3GEYJ221V	220 1/16W	[M]
R2070	ERJ3GEYJ221V	220 1/16W	[M]
R2071	ERJ3GEYJ221V	220 1/16W	[M]

Ref. No.	Part No.	Part Name & Description	Remarks
R2072	ERJ3GEYJ221V	220 1/16W	[M]
R2073	ERJ3GEYJ221V	220 1/16W	[M]
R2075	ERJ3GEYJ221V	220 1/16W	[M]
R2076	ERJ3GEYJ103V	10K 1/16W	[M]
R2077	ERJ3GEYJ103V	10K 1/16W	[M]
R2078	ERJ3GEYJ472V	4.7K 1/16W	[M]
R2079	ERJ3GEYJ103V	10K 1/16W	[M]
R2080	ERJ3GEYJ182V	1.8K 1/16W	[M]
R2081	ERJ3GEYJ103V	10K 1/16W	[M]
R2082	ERJ3GEYJ124V	120K 1/16W	[M]
R2084	ERJ3GEYJ473V	47K 1/16W	[M]
R2085	ERJ3GEYJ472V	4.7K 1/16W	[M]
R2086	ERJ3GEYJ223V	22K 1/16W	[M]
R2087	ERJ3GEYJ223V	22K 1/16W	[M]
R2088	ERJ3GEYJ103V	10K 1/16W	[M]
R2089	ERJ3GEYJ821V	820 1/16W	[M]
R2090	ERJ3GEYJ221V	220 1/16W	[M]
R2091	ERJ3GEYJ103V	10K 1/16W	[M]
R2092	ERJ3GEYJ221V	220 1/16W	[M]
R2093	ERJ3GEYJ682V	6.8K 1/16W	[M]
R2094	ERJ3GEYJ103V	10K 1/16W	[M]
R2095	ERJ3GEYJ472V	4.7K 1/16W	[M]
R2096	ERJ3GEYJ103V	10K 1/16W	[M]
R2097	ERJ3GEYJ474V	470K 1/16W	[M]
R2101	ERJ3GEYJ123V	12K 1/16W	[M]
R2111	ERJ3GEYJ123V	12K 1/16W	[M]
R2112	ERJ3GEYJ123V	12K 1/16W	[M]
R2113	ERJ3GEYJ472V	4.7K 1/16W	[M]
R2114	ERJ3GEYJ472V	4.7K 1/16W	[M]
R2115	ERJ3GEYJ103V	10K 1/16W	[M]
R2160	ERJ3GEYJ563V	56K 1/16W	[M]
R2161	ERJ3GEYJ473V	47K 1/16W	[M]
R2164	ERJ3GEYJ103V	10K 1/16W	[M]
R2165	ERJ3GEYJ332V	3.3K 1/16W	[M]
R2185	ERJ3GEYJ103V	10K 1/16W	[M]
R2191	ERJ3GEYJ682V	6.8K 1/16W	[M]
R2194	ERJ3GEYJ273V	27K 1/16W	[M]
R2201	ERJ3GEYJ123V	12K 1/16W	[M]
R2211	ERJ3GEYJ123V	12K 1/16W	[M]
R2212	ERJ3GEYJ123V	12K 1/16W	[M]
R2214	ERJ3GEYJ472V	4.7K 1/16W	[M]
R2215	ERJ3GEYJ103V	10K 1/16W	[M]
R2218	ERJ3GEYJ472V	4.7K 1/16W	[M]
R2260	ERJ3GEYJ563V	56K 1/16W	[M]
R2261	ERJ3GEYJ473V	47K 1/16W	[M]
R2264	ERJ3GEYJ103V	10K 1/16W	[M]
R2265	ERJ3GEYJ332V	3.3K 1/16W	[M]
R2285	ERJ3GEYJ103V	10K 1/16W	[M]
R2291	ERJ3GEYJ682V	6.8K 1/16W	[M]
R2294	ERJ3GEYJ273V	27K 1/16W	[M]
R2300	ERJ3GEYJ223V	22K 1/16W	[M]
R2301	ERJ3GEYJ182V	1.8K 1/16W	[M]
R2302	ERJ3GEYJ103V	10K 1/16W	[M]
R2303	ERJ3GEYJ103V	10K 1/16W	[M]
R2304	ERJ3GEYJ123V	12K 1/16W	[M]
R2307	ERJ3GEYJ182V	1.8K 1/16W	[M]
R2312	ERJ3GEYJ103V	10K 1/16W	[M]
R2336	ERJ3GEYJ123V	12K 1/16W	[M]
R2339	ERJ3GEYJ104V	100K 1/16W	[M]
R2400	ERJ3GEYJ223V	22K 1/16W	[M]
R2401	ERJ3GEYJ182V	1.8K 1/16W	[M]
R2402	ERJ3GEYJ103V	10K 1/16W	[M]
R2403	ERJ3GEYJ103V	10K 1/16W	[M]
R2404	ERJ3GEYJ123V	12K 1/16W	[M]
R2405	ERJ3GEYJ182V	1.8K 1/16W	[M]
R2406	ERJ3GEYJ182V	1.8K 1/16W	[M]
R2407	ERJ3GEYJ182V	1.8K 1/16W	[M]
R2412	ERJ3GEYJ103V	10K 1/16W	[M]
R2436	ERJ3GEYJ123V	12K 1/16W	[M]
R2439	ERJ3GEYJ104V	100K 1/16W	[M]
R2500	ERJ3GEYJ223V	22K 1/16W	[M]
R2501	ERJ3GEYJ682V	6.8K 1/16W	[M]
R2502	ERJ3GEYJ103V	10K 1/16W	[M]

Ref. No.	Part No.	Part Name & Description	Remarks
R2503	ERJ3GEYJ682V	6.8K 1/16W	[M]
R2510	ERJ3GEYJ153V	15K 1/16W	[M]
R2511	ERJ3GEYJ123V	12K 1/16W	[M]
R2512	ERJ3GEYJ104V	100K 1/16W	[M]
R2600	ERJ3GEYJ102V	1K 1/16W	[M]
R2601	ERJ3GEYJ473V	47K 1/16W	[M]
R2606	ERJ3GEYJ103V	10K 1/16W	[M]
R2607	ERJ3GEYJ103V	10K 1/16W	[M]
R2608	ERJ3GEYJ563V	56K 1/16W	[M]
R2609	ERJ3GEYJ152V	1.5K 1/16W	[M]
R2610	ERJ3GEYJ563V	56K 1/16W	[M]
R2611	ERJ3GEYJ122V	1.2K 1/16W	[M]
R2612	ERJ3GEYJ563V	56K 1/16W	[M]
R2617	ERJ3GEYJ223V	22K 1/16W	[M]
R2619	ERJ3GEYJ203V	20K 1/16W	[M]
R2620	ERJ3GEYJ123V	12K 1/16W	[M]
R2621	ERJ3GEYJ393V	39K 1/16W	[M]
R2626	ERJ3GEYJ104V	100K 1/16W	[M]
R2627	ERJ3GEYJ683V	68K 1/16W	[M]
R2807	ERJ3GEYJ102V	1K 1/16W	[M]
R2900	ERJ3GEYJ1R0V	1 1/16W	[M]
R2904	ERJ3GEYJ101V	100 1/16W	[M]
R2905	ERJ3GEYJ221V	220 1/16W	[M]
R2907	ERJ3GEYJ392V	3.9K 1/16W	[M]
R2908	ERJ3GEYJ391V	390 1/16W	[M]
R2911	ERG2SJ470E	47 2W	[M] △
R2912	ERG2SJ470E	47 2W	[M] △
R2913	ERG2SJ470E	47 2W	[M] △
R2914	ERJ3GEYJ272V	2.7K 1/16W	[M]
R2915	ERJ3GEYJ272V	2.7K 1/16W	[M]
R2919	ERJ3GEYJ274V	270K 1/16W	[M]
R2920	ERJ3GEYF392V	3.9K 1/16W	[M]
R2921	ERJ3GEYF273V	27K 1/16W	[M]
R2924	ERJ3GEYJ683V	68K 1/16W	[M]
R2926	ERX2SJR5E	1.5 2W	[M]
R2929	ERJ3GEYJ182V	1.8K 1/16W	[M]
R2933	ERJ3GEYJ151V	150 1/16W	[M]
R2934	ERJ3GEYJ821V	820 1/16W	[M]
R2936	ERJ3GEYJ224V	220K 1/16W	[M]
R2938	ERJ3GEYJ103V	10K 1/16W	[M]
R2940	ERJ3GEYJ393V	39K 1/16W	[M]
R2941	ERJ3GEYJ473V	47K 1/16W	[M]
R2942	ERJ3GEYJ222V	2.2K 1/16W	[M]
R2943	ERJ3GEYJ272V	2.7K 1/16W	[M]
R2944	ERJ3GEYJ472V	4.7K 1/16W	[M]
R2950	ERJ3GEYJ102V	1K 1/16W	[M]
R2952	ERJ3GEYJ8R2V	8.2 1/16W	[M]
R2960	ERJ3GEYJ150V	15 1/16W	[M]
R2963	ERJ3GEYJ222V	2.2K 1/16W	[M]
R2964	ERJ3GEYJ220V	22 1/16W	[M]
R2968	ERJ6GEYJ151V	150 1/10W	[M]
R2969	ERJ6GEYJ151V	150 1/10W	[M]
R2970	ERJ3GEYJ220V	22 1/16W	[M]
R2971	ERX2SJR5E	1.5 2W	[M]
R2972	ERJ3GEYJ220V	22 1/16W	[M]
R2973	ERJ3GEYJ151V	150 1/16W	[M]
R2974	ERD2FCVJ4R7T	4.7 1/4W	[M] △
R2975	ERJ3GEYJ472V	4.7K 1/16W	[M]
R2976	ERJ3GEYJ151V	150 1/16W	[M]
R2980	ERJ3GEYJ102V	1K 1/16W	[M]
R2981	ERG2SJ220E	22 2W	[M]
R2982	ERG2SJ220E	22 2W	[M]
R2983	ERG2SJ220E	22 2W	[M]
R2984	ERG2SJ220E	22 2W	[M]
R2985	ERG2SJ220E	22 2W	[M]
R2986	ERG2SJ220E	22 2W	[M]
R2998	ERJ3GEYJ223V	22K 1/16W	[M]
R2999	ERJ3GEYJ223V	22K 1/16W	[M]
R3003	ERJ3GEYJ182V	1.8K 1/16W	[M]
R3005	ERJ3GEYJ223V	22K 1/16W	[M]
R3006	ERJ3GEYJ102V	1K 1/16W	[M]
R3007	ERJ3GEYJ273V	27K 1/16W	[M]
R3008	ERJ3GEYJ182V	1.8K 1/16W	[M]

Ref. No.	Part No.	Part Name & Description	Remarks
R3009	ERJ3GEYJ102V	1K 1/16W	[M]
R3014	ERJ3GEYJ563V	56K 1/16W	[M]
R3015	ERJ3GEYJ273V	27K 1/16W	[M]
R5101	ERJ3GEYJ472V	4.7K 1/16W	[M]
R5102	ERJ3GEYJ472V	4.7K 1/16W	[M]
R5104	ERJ3GEYJ273V	27K 1/16W	[M]
R5105	DOC1220JA020	1.2K 1W	[M]
R5106	DOC1220JA020	1.2K 1W	[M]
R5108	ERJ3GEYJ273V	27K 1/16W	[M]
R5109	DOC1220JA020	1.2K 1W	[M]
R5110	DOC1220JA020	1.2K 1W	[M]
R5111	ERJ3GEYJ103V	10K 1/16W	[M]
R5112	ERJ3GEYJ102V	1K 1/16W	[M]
R5201	ERJ3GEYJ153V	15K 1/16W	[M]
R5202	ERJ3GEYJ153V	15K 1/16W	[M]
R5204	ERJ3GEYJ273V	27K 1/16W	[M]
R5205	DOC1220JA020	1.2K 1W	[M]
R5206	DOC1220JA020	1.2K 1W	[M]
R5208	ERJ3GEYJ273V	27K 1/16W	[M]
R5209	DOC1220JA020	1.2K 1W	[M]
R5210	DOC1220JA020	1.2K 1W	[M]
R5211	ERJ3GEYJ103V	10K 1/16W	[M]
R5212	ERJ3GEYJ102V	1K 1/16W	[M]
R5301	ERJ3GEYJ272V	2.7K 1/16W	[M]
R5302	ERJ3GEYJ153V	15K 1/16W	[M]
R5304	ERJ3GEYJ562V	5.6K 1/16W	[M]
R5305	DOC1220JA020	1.2K 1W	[M]
R5306	DOC1220JA020	1.2K 1W	[M]
R5308	ERJ3GEYJ273V	27K 1/16W	[M]
R5309	DOC1220JA020	1.2K 1W	[M]
R5310	DOC1220JA020	1.2K 1W	[M]
R5311	ERJ3GEYJ103V	10K 1/16W	[M]
R5312	ERJ3GEYJ102V	1K 1/16W	[M]
R5313	ERJ3GEYJ473V	47K 1/16W	[M]
R5533	ERJ3GEYJ223V	22K 1/16W	[M]
R5534	ERJ3GEYJ183V	18K 1/16W	[M]
R5736	ERJ3GEYJ222V	2.2K 1/16W	[M]
R5754	ERJ3GEYJ563V	56K 1/16W	[M]
R5755	ERJ3GEYJ103V	10K 1/16W	[M]
R5756	ERJ3GEYJ103V	10K 1/16W	[M]
R5757	ERJ3GEYJ103V	10K 1/16W	[M]
R5758	ERJ3GEYJ335V	3.3M 1/16W	[M]
R5759	ERJ3GEYJ104V	100K 1/16W	[M]
R5760	ERJ3GEYJ103V	10K 1/16W	[M]
R5761	ERJ3GEYJ225V	2.2M 1/16W	[M]
R5762	ERJ3GEYJ154V	150K 1/16W	[M]
R5763	ERJ3GEYJ272V	2.7K 1/16W	[M]
R5764	ERJ3GEYJ392V	3.9K 1/16W	[M]
R5765	ERJ3GEYJ103V	10K 1/16W	[M]
R5766	ERJ3GEYJ103V	10K 1/16W	[M]
R6801	ERJ3GEYJ102V	1K 1/16W	[M]
R6802	ERJ3GEYJ102V	1K 1/16W	[M]
R6803	ERJ3GEYJ122V	1.2K 1/16W	[M]
R6804	ERJ3GEYJ182V	1.8K 1/16W	[M]
R6805	ERJ3GEYJ222V	2.2K 1/16W	[M]
R6905	ERJ3GEYJ152V	1.5K 1/16W	[M]
R6914	ERJ3GEYJ823V	82K 1/16W	[M]
R6916	ERJ3GEYJ680V	68 1/16W	[M]
R6917	ERJ3GEYJ102V	1K 1/16W	[M]
R6918	ERJ3GEYJ223V	22K 1/16W	[M]
R6919	ERJ3GEYJ680V	68 1/16W	[M]
R6934	ERJ3GEYJ470V	47 1/16W	[M]
R6936	ERJ3GEYJ151V	150 1/16W	[M]
R6939	ERJ3GEYOR00V	0 1/16W	[M]
R6940	ERJ3GEYOR00V	0 1/16W	[M]
R8003	ERJ2GEJ473X	47K 2W	[M]
R8011	ERJ2GEJ220X	22 2W	[M]
R8012	ERJ2GEJ220X	22 2W	[M]
R8013	ERJ2GEJ220X	22 2W	[M]
R8041	ERJ2GEJ330X	33 2W	[M]
R8153	ERJ2RHD621X	620 2W	[M]
R8154	ERJ2RHD102X	1K 2W	[M]
R8211	ERJ2GEJ103X	10K 2W	[M]

Ref. No.	Part No.	Part Name & Description	Remarks
R8221	ERJ2GEJ822X	8.2K 2W	[M]
R8225	ERJ2GEJ822X	8.2K 2W	[M]
R8230	ERJ2GEJ222X	2.2K 2W	[M]
R8231	ERJ2GEJ223X	22K 2W	[M]
R8232	ERJ2GEJ752X	7.5K 2W	[M]
R8251	ERJ6GEYJ6R8V	6.8 1/10W	[M]
R8261	ERJ2GEJ823X	82K 2W	[M]
R8262	ERJ2GEJ153X	15K 2W	[M]
R8263	ERJ2GEJ823X	82K 2W	[M]
R8264	ERJ2GEJ153X	15K 2W	[M]
R8311	ERJ2RHD242X	2.4K 2W	[M]
R8312	ERJ2RHD102X	1K 2W	[M]
R8313	ERJ2RHD912X	9.1K 2W	[M]
R8314	ERJ2GEOR00X	0 2W	[M]
R8321	ERJ3RED680V	68 3W	[M]
R8322	ERJ3GEYOR00V	0 1/16W	[M]
R8325	ERJ3RED680V	68 3W	[M]
R8326	ERJ3GEYOR00V	0 1/16W	[M]
R8331	ERJ3RED680V	68 3W	[M]
R8332	ERJ3GEYOR00V	0 1/16W	[M]
R8335	ERJ3RED680V	68 3W	[M]
R8341	ERJ3RED680V	68 3W	[M]
R8401	ERJ2GEJ101X	100 2W	[M]
R8420	ERJ2GEJ222X	2.2K 2W	[M]
R8421	ERJ2GEOR00X	0 2W	[M]
R8531	ERJ2GEJ152X	1.5K 2W	[M]
R8532	ERJ2GEJ222X	2.2K 2W	[M]
R8533	ERJ2GEOR00X	0 2W	[M]
R8541	ERJ2GEJ153X	15K 2W	[M]
R8551	ERJ2GEOR00X	0 2W	[M]
R8552	ERJ2GEJ102X	1K 2W	[M]
R8553	ERJ2GEJ102X	1K 2W	[M]
R8554	ERJ2GEJ680X	68 2W	[M]
R8555	ERJ2GEJ2R2X	2.2 2W	[M]
R8556	ERJ3GEYJ560V	56 1/16W	[M]
R8557	ERJ3GEYJ510V	51 1/16W	[M]
R8558	ERJ2GEJ473X	47K 2W	[M]
R8559	ERJ2GEJ153X	15K 2W	[M]
R8561	ERJ2GEOR00X	0 2W	[M]
R8562	ERJ2GEJ102X	1K 2W	[M]
R8563	ERJ2GEJ102X	1K 2W	[M]
R8564	ERJ2GEJ220X	22 2W	[M]
R8565	ERJ2GEJ2R2X	2.2 2W	[M]
R8566	ERJ3GEYJ560V	56 1/16W	[M]
R8567	ERJ3GEYJ510V	51 1/16W	[M]
R8568	ERJ2GEJ473X	47K 2W	[M]
R8601	ERJ2GEJ104X	100K 2W	[M]
R8611	ERJ2GEJ101X	100 2W	[M]
R8621	ERJ2GEJ105X	1M 2W	[M]
R8622	ERJ2RHD102X	1K 2W	[M]
RX8001	D1H410320002	CHIP RESISTOR	[M]
RX8011	D1H88204A024	CHIP RESISTOR	[M]
RX8012	D1H88204A024	CHIP RESISTOR	[M]
RX8013	D1H88204A024	CHIP RESISTOR	[M]
RX8014	D1H88204A024	CHIP RESISTOR	[M]
RX8015	D1H88204A024	CHIP RESISTOR	[M]
RX8016	D1H88204A024	CHIP RESISTOR	[M]
RX8017	D1H88204A024	CHIP RESISTOR	[M]
RX8018	D1H422020001	CHIP RESISTOR	[M]
RX8019	D1H422020001	CHIP RESISTOR	[M]
RX8020	D1H422020001	CHIP RESISTOR	[M]
RX8031	D1H447220001	CHIP RESISTOR	[M]
RX8032	D1H447220001	CHIP RESISTOR	[M]
RX8111	D1H422320002	CHIP RESISTOR	[M]
RX8401	D1H410120001	CHIP RESISTOR	[M]
RX8402	D1H410120001	CHIP RESISTOR	[M]
RX8403	D1H410120001	CHIP RESISTOR	[M]
RX8531	D1H456020001	CHIP RESISTOR	[M]
RX8532	D1H85604A024	CHIP RESISTOR	[M]
RX8533	D1H456020001	CHIP RESISTOR	[M]
RX8534	D1H456020001	CHIP RESISTOR	[M]
RX8611	D1H447220001	CHIP RESISTOR	[M]

Ref. No.	Part No.	Part Name & Description	Remarks
RX8691	D1H410320002	CHIP RESISTOR	[M]
W2501	ERJ6GEY0R00V	CHIP RESISTOR	[M]
W2503	ERJ6GEY0R00V	CHIP RESISTOR	[M]
W2504	ERJ6GEY0R00V	CHIP RESISTOR	[M]
W2505	ERJ3GEY0R00V	CHIP JUMPER	[M]
W2506	ERJ3GEY0R00V	CHIP JUMPER	[M]
W2508	ERJ6GEY0R00V	CHIP RESISTOR	[M]
W2509	ERJ6GEY0R00V	CHIP RESISTOR	[M]
W2512	ERJ3GEY0R00V	CHIP JUMPER	[M]
W2513	ERJ6GEY0R00V	CHIP RESISTOR	[M]
W2514	ERJ6GEY0R00V	CHIP RESISTOR	[M]
W2515	ERJ6GEY0R00V	CHIP RESISTOR	[M]
W2516	ERJ6GEY0R00V	CHIP RESISTOR	[M]
W2517	ERJ6GEY0R00V	CHIP RESISTOR	[M]
W2519	ERJ6GEY0R00V	CHIP RESISTOR	[M]
W2520	ERJ6GEY0R00V	CHIP RESISTOR	[M]
W2521	ERJ3GEY0R00V	CHIP JUMPER	[M]
W2522	ERJ6GEY0R00V	CHIP RESISTOR	[M]
W2523	ERJ3GEY0R00V	CHIP JUMPER	[M]
W2524	ERJ3GEY0R00V	CHIP JUMPER	[M]
W2525	ERJ6GEY0R00V	CHIP RESISTOR	[M]
W2527	ERJ6GEY0R00V	CHIP RESISTOR	[M]
W2528	ERJ6GEY0R00V	CHIP RESISTOR	[M]
W2529	ERJ3GEY0R00V	CHIP JUMPER	[M]
W2530	ERJ6GEY0R00V	CHIP RESISTOR	[M]
W2531	ERJ6GEY0R00V	CHIP RESISTOR	[M]
W2532	ERJ3GEY0R00V	CHIP JUMPER	[M]
W2533	ERJ6GEY0R00V	CHIP RESISTOR	[M]
W2534	ERJ6GEY0R00V	CHIP RESISTOR	[M]
W2536	ERJ6GEY0R00V	CHIP RESISTOR	[M]
W2537	ERJ6GEY0R00V	CHIP RESISTOR	[M]
W2538	ERJ3GEY0R00V	CHIP JUMPER	[M]
W2539	ERJ3GEY0R00V	CHIP JUMPER	[M]
W2540	ERJ3GEY0R00V	CHIP JUMPER	[M]
W2541	ERJ3GEY0R00V	CHIP JUMPER	[M]
W2542	ERJ6GEY0R00V	CHIP RESISTOR	[M]
W2543	ERJ3GEY0R00V	CHIP JUMPER	[M]
W2544	ERJ3GEY0R00V	CHIP JUMPER	[M]
W2545	ERJ3GEY0R00V	CHIP JUMPER	[M]
W2546	ERJ6GEY0R00V	CHIP RESISTOR	[M]
W2547	ERJ6GEY0R00V	CHIP RESISTOR	[M]
W2548	ERJ6GEY0R00V	CHIP RESISTOR	[M]
W2550	ERJ6GEY0R00V	CHIP RESISTOR	[M]
W2552	ERJ6GEY0R00V	CHIP RESISTOR	[M]
W2553	ERJ6GEY0R00V	CHIP RESISTOR	[M]
W2554	ERJ6GEY0R00V	CHIP RESISTOR	[M]
W2556	ERJ3GEY0R00V	CHIP JUMPER	[M]
W2558	ERJ6GEY0R00V	CHIP RESISTOR	[M]
W2559	ERJ6GEY0R00V	CHIP RESISTOR	[M]
W2560	ERJ3GEY0R00V	CHIP JUMPER	[M]
W2561	ERJ6GEY0R00V	CHIP RESISTOR	[M]
W2562	ERJ3GEY0R00V	CHIP JUMPER	[M]
W2563	ERJ6GEY0R00V	CHIP RESISTOR	[M]
W2564	ERJ3GEY0R00V	CHIP JUMPER	[M]
W2566	ERJ3GEY0R00V	CHIP JUMPER	[M]
W2567	ERJ6GEY0R00V	CHIP RESISTOR	[M]
W2570	ERJ6GEY0R00V	CHIP RESISTOR	[M]
W2571	ERJ6GEY0R00V	CHIP RESISTOR	[M]
W2572	ERJ6GEY0R00V	CHIP RESISTOR	[M]
W2573	ERJ6GEY0R00V	CHIP RESISTOR	[M]
W2574	ERJ3GEY0R00V	CHIP JUMPER	[M]
W2575	ERJ6GEY0R00V	CHIP RESISTOR	[M]
W2576	ERJ6GEY0R00V	CHIP RESISTOR	[M]
W2577	ERJ6GEY0R00V	CHIP RESISTOR	[M]
W2578	ERJ6GEY0R00V	CHIP RESISTOR	[M]
W2579	ERJ6GEY0R00V	CHIP RESISTOR	[M]
W2580	ERJ6GEY0R00V	CHIP RESISTOR	[M]
W2581	ERJ3GEY0R00V	CHIP JUMPER	[M]
W2582	ERJ3GEY0R00V	CHIP JUMPER	[M]
W2583	ERJ3GEY0R00V	CHIP JUMPER	[M]
W2584	ERJ6GEY0R00V	CHIP RESISTOR	[M]
W2585	ERJ3GEY0R00V	CHIP JUMPER	[M]

Ref. No.	Part No.	Part Name & Description	Remarks
W2586	ERJ3GEY0R00V	CHIP JUMPER	[M]
W2587	ERJ6GEY0R00V	CHIP RESISTOR	[M]
W2588	ERJ6GEY0R00V	CHIP RESISTOR	[M]
W2589	ERJ6GEY0R00V	CHIP RESISTOR	[M]
W2590	ERJ3GEY0R00V	CHIP JUMPER	[M]
W2591	ERJ6GEY0R00V	CHIP RESISTOR	[M]
W2592	ERJ6GEY0R00V	CHIP RESISTOR	[M]
W2593	ERJ6GEY0R00V	CHIP RESISTOR	[M]
W2595	ERJ6GEY0R00V	CHIP RESISTOR	[M]
W2596	ERJ3GEY0R00V	CHIP JUMPER	[M]
W2597	ERJ3GEY0R00V	CHIP JUMPER	[M]
W2901	ERJ3GEY0R00V	CHIP JUMPER	[M]
W6501	ERJ3GEY0R00V	CHIP JUMPER	[M]
W6502	ERJ6GEY0R00V	CHIP RESISTOR	[M]
W6504	ERJ6GEY0R00V	CHIP RESISTOR	[M]
W6509	ERJ3GEY0R00V	CHIP JUMPER	[M]
W6511	ERJ6GEY0R00V	CHIP RESISTOR	[M]
W6512	ERJ6GEY0R00V	CHIP RESISTOR	[M]
W6513	ERJ3GEY0R00V	CHIP JUMPER	[M]
W6545	ERJ6GEY0R00V	CHIP RESISTOR	[M]
		WIRES	
K8001	ERJ2GE0R00X	CHIP JUMPER	[M]
K8006	ERJ2GE0R00X	CHIP JUMPER	[M]
K8251	ERJ3GEY0R00V	CHIP JUMPER	[M]
K8321	ERJ2GE0R00X	CHIP JUMPER	[M]
K8325	ERJ2GE0R00X	CHIP JUMPER	[M]
K8331	ERJ2GE0R00X	CHIP JUMPER	[M]
K8335	ERJ2GE0R00X	CHIP JUMPER	[M]
K8341	ERJ2GE0R00X	CHIP JUMPER	[M]
K8421	ERJ3GEY0R00V	CHIP JUMPER	[M]
		CAPACITORS	
C984	ECA1EAK100XE	10 25V	[M]
C1001	ECA1CM101B	100 16V	[M]
C1002	ECJ1VB1H104K	0.1 50V	[M]
C1004	ECJ1VB1H103K	0.01 50V	[M]
C1005	ECJ1VB1H103K	0.01 50V	[M]
C1006	ECJ1VB1H104K	0.1 50V	[M]
C1007	ECA1HM220B	22 50V	[M]
C1008	ECJ1VB1C105K	1 16V	[M]
C1009	ECJ1VB1C105K	1 16V	[M]
C1010	ECJ1VB1C105K	1 16V	[M]
C1011	ECJ1VB1H103K	0.01 50V	[M]
C1012	ECA0JM102B	1000 6.3V	[M]
C1014	ECA0JM102B	1000 6.3V	[M]
C1015	ECA0JM331B	330 6.3V	[M]
C1016	ECJ1VB1C105K	1 16V	[M]
C1017	ECA0JM102B	1000 6.3V	[M]
C1018	ECJ1VC1H101J	100P 50V	[M]
C1019	ECJ1VC1H101J	100P 50V	[M]
C1020	ECJ1VC1H101J	100P 50V	[M]
C1021	ECJ1VC1H101J	100P 50V	[M]
C1022	ECJ1VC1H101J	100P 50V	[M]
C1100	ECJ1VC1H101J	100P 50V	[M]
C1200	ECJ1VC1H101J	100P 50V	[M]
C2000	ECJ1VB1H104K	0.1 50V	[M]
C2001	ECJ1VB1H104K	0.1 50V	[M]
C2003	ECA1HM220B	22 50V	[M]
C2004	ECJ1VB1H103K	0.01 50V	[M]
C2006	ECA1HM3R3B	3.3 50V	[M]
C2007	ECJ1VB1C104K	0.1 16V	[M]
C2008	ECA0JM101B	100 6.3V	[M]
C2009	ECJ1VB1H104K	0.1 50V	[M]
C2010	ECJ1VB1H331K	330P 50V	[M]
C2011	ECJ1VB1H331K	330P 50V	[M]
C2012	ECJ1VB1H331K	330P 50V	[M]
C2013	ECJ1VB1H223K	0.022 50V	[M]
C2017	ECJ1VB1H103K	0.01 50V	[M]
C2018	ECA1CM470B	47 16V	[M]
C2019	ECA1CM470B	47 16V	[M]

Ref. No.	Part No.	Part Name & Description	Remarks
C2020	ECJ1VB1H103K	0.01 50V	[M]
C2021	ECA1AM221B	220 10V	[M]
C2022	ECA1CM101B	100 16V	[M]
C2023	ECJ1VB1H221K	220P 50V	[M]
C2024	ECJ1VB1H221K	220P 50V	[M]
C2026	ECJ1VB1A105K	1 10V	[M]
C2101	ECJ1VB1C105K	1 10V	[M]
C2111	ECJ1VB1C105K	1 10V	[M]
C2112	ECJ1VB1H471K	470P 50V	[M]
C2114	ECJ1VB1H223K	0.022 50V	[M]
C2115	ECJ1VB1H153K	0.015 50V	[M]
C2116	ECJ1VB1H472K	4700P 50V	[M]
C2117	ECJ1VB1H473K	0.047 50V	[M]
C2118	ECJ1VB1C224K	0.22 16V	[M]
C2119	ECJ1VB1C105K	1 16V	[M]
C2120	ECJ1VB1C393K	0.039 16V	[M]
C2121	ECJ1VB1H473K	0.047 50V	[M]
C2161	ECJ1VB1C183K	0.018 16V	[M]
C2162	ECJ1VB1H681K	680P 50V	[M]
C2164	ECJ1VB1H221K	220P 50V	[M]
C2169	ECJ1VB1H103K	0.01 50V	[M]
C2172	ECJ1VC1H101J	100P 50V	[M]
C2183	ECJ1VB1A105K	1 10V	[M]
C2195	ECJ1VB1A105K	1 10V	[M]
C2201	ECJ1VB1C105K	1 10V	[M]
C2211	ECJ1VB1C105K	1 10V	[M]
C2212	ECJ1VB1H471K	470P 50V	[M]
C2214	ECJ1VB1H223K	0.022 50V	[M]
C2215	ECJ1VB1H153K	0.015 50V	[M]
C2216	ECJ1VB1H472K	4700P 50V	[M]
C2217	ECJ1VB1H473K	0.047 50V	[M]
C2218	ECJ1VB1C224K	0.22 16V	[M]
C2219	ECJ1VB1C105K	1 16V	[M]
C2220	ECJ1VB1C393K	0.039 16V	[M]
C2221	ECJ1VB1H473K	0.047 50V	[M]
C2261	ECJ1VB1C183K	0.018 16V	[M]
C2262	ECJ1VB1H681K	680P 50V	[M]
C2264	ECJ1VB1H221K	220P 50V	[M]
C2272	ECJ1VC1H101J	100P 50V	[M]
C2283	ECJ1VB1A105K	1 10V	[M]
C2295	ECJ1VB1A105K	1 10V	[M]
C2300	ECJ1VB1A105K	1 10V	[M]
C2301	ECJ1VB1A105K	1 10V	[M]
C2302	ECJ1VB1C333K	0.033 16V	[M]
C2303	ECJ1VB1H473K	0.047 50V	[M]
C2304	ECA1CM100B	10 16V	[M]
C2305	ECJ1VB1H332K	3300P 50V	[M]
C2306	ECJ1VB1A105K	1 10V	[M]
C2307	ECA1CM100B	10 16V	[M]
C2308	ECJ1VB1H223K	0.022 50V	[M]
C2309	ECJ1VB1C823K	0.082 16V	[M]
C2312	ECJ1VB1A105K	1 10V	[M]
C2323	ECJ1VC1H101J	100P 50V	[M]
C2324	ECJ1VB1H222K	2200P 50V	[M]
C2400	ECJ1VB1A105K	1 10V	[M]
C2401	ECJ1VB1A105K	1 10V	[M]
C2402	ECJ1VB1C333K	0.033 16V	[M]
C2403	ECJ1VB1H473K	0.047 50V	[M]
C2404	ECA1CM100B	10 16V	[M]
C2405	ECJ1VB1H332K	3300P 50V	[M]
C2406	ECJ1VB1A105K	1 10V	[M]
C2407	ECA1CM100B	10 16V	[M]
C2408	ECJ1VB1A105K	1 10V	[M]
C2410	ECA1CM101B	100 16V	[M]
C2411	ECJ1VB1H104K	0.1 50V	[M]
C2412	ECJ1VB1A105K	1 10V	[M]
C2423	ECJ1VC1H101J	100P 50V	[M]
C2424	ECJ1VB1H222K	2200P 50V	[M]
C2500	ECJ1VB1A105K	1 10V	[M]
C2501	ECJ1VB1C105K	1 16V	[M]
C2502	ECJ1VB1H473K	0.047 50V	[M]
C2503	ECJ1VB1H473K	0.047 50V	[M]
C2506	ECJ1VB1A105K	1 10V	[M]

Ref. No.	Part No.	Part Name & Description	Remarks
C2507	ECJ1VB1H471K	470P 50V	[M]
C2524	ECJ1VB1H682K	6800P 50V	[M]
C2600	ECJ1VB1A105K	1 10V	[M]
C2601	ECJ1VB1H223K	0.022 50V	[M]
C2605	ECJ1VB1H473K	0.047 50V	[M]
C2606	ECA1CM100B	10 16V	[M]
C2607	ECA1HM220B	22 50V	[M]
C2608	ECA1CM100B	10 16V	[M]
C2609	ECJ1VB1C224K	0.22 16V	[M]
C2610	ECJ1VB1A474K	0.47 10V	[M]
C2611	ECJ1VB1H123K	0.012 50V	[M]
C2612	ECJ1VB1H332K	3300P 50V	[M]
C2615	ECJ1VB1H222K	2200P 50V	[M]
C2617	ECJ1VB1A154K	0.15 10V	[M]
C2619	ECA1HM100B	10 50V	[M]
C2624	ECJ1VB1H682K	6800P 50V	[M]
C2724	ECJ1VB1H182K	1800P 50V	[M]
C2819	ECJ1VC1H101J	100P 50V	[M]
C2820	ECJ1VC1H101J	100P 50V	[M]
C2821	ECJ1VC1H101J	100P 50V	[M]
C2822	ECJ1VC1H101J	100P 50V	[M]
C2831	ECJ1VB1H102K	1000P 50V	[M]
C2832	ECJ1VB1H102K	1000P 50V	[M]
C2833	ECA1CM100B	10 16V	[M]
C2853	ECJ1VC1H101J	100P 50V	[M]
C2900	EUFC1C471B	470P 16V	[M]
C2901	ECA1CM471B	470 16V	[M]
C2902	ECJ1VB1H103K	0.01 50V	[M]
C2903	ECJ1VB1H103K	0.01 50V	[M]
C2904	ERJ3GEY0R00V	0 1/16W	[M]
C2906	ECJ1VB1H103K	0.01 50V	[M]
C2908	ECA1CM101B	100 16V	[M]
C2910	ECJ1VB1H103K	0.01 50V	[M]
C2913	ECA1CM101B	100 16V	[M]
C2914	ECA1AM330B	33 10V	[M]
C2919	ECJ1VC1H100D	10P 50V	[M]
C2920	ECJ1VB1H822K	8200P 50V	[M]
C2921	ECA1CM471B	470 16V	[M]
C2922	EUFC1C471B	470P 16V	[M]
C2924	ECJ1VB1H104K	0.1 50V	[M]
C2925	ECA0JM221B	220 6.3V	[M]
C2940	ECJ1VB1H103K	0.01 50V	[M]
C2941	ECA1CM101B	100 16V	[M]
C2945	ECJ1VB1H104K	0.1 50V	[M]
C2946	ECA1CM470B	47 16V	[M]
C2952	ECJ1VB1H104K	0.1 50V	[M]
C2959	ECJ1VB1A105K	1 10V	[M]
C2961	ECJ1VB1A105K	1 10V	[M]
C2963	ECJ1VB1A105K	1 10V	[M]
C2964	ECJ1VB1A105K	1 10V	[M]
C2965	ECJ1VB1C104K	0.1 16V	[M]
C2966	ECJ1VB1H104K	0.1 50V	[M]
C2967	ECA1CM221B	220 16V	[M]
C2968	ECA1CM101B	100 16V	[M]
C2969	ECJ1VB1H104K	0.1 50V	[M]
C2970	ECJ1VB1H104K	0.1 50V	[M]
C2971	ECA1CM101B	100 16V	[M]
C2972	ECJ1VB1H104K	0.1 50V	[M]
C2973	ECA1CM101B	100 16V	[M]
C2974	ECJ1VB1H104K	0.1 50V	[M]
C2975	ECA1CM101B	100 16V	[M]
C2976	ECJ1VB1H104K	0.1 50V	[M]
C2977	ECA1CM101B	100 16V	[M]
C2978	ECJ1VB1H104K	0.1 50V	[M]
C2981	ECA1CM101B	100 16V	[M]
C2982	ECJ1VB1H104K	0.1 50V	[M]
C2983	ECA1CM101B	100 16V	[M]
C2984	ECJ1VB1H104K	0.1 50V	[M]
C2985	ECJ1VB1H103K	0.01 50V	[M]
C2986	ECA1HM101B	100 50V	[M]
C3001	ECJ1VB1A105K	1 10V	[M]
C3002	ECJ1VB1A105K	1 10V	[M]
C3003	ECJ1VB1A105K	1 10V	[M]

Ref. No.	Part No.	Part Name & Description	Remarks
C3004	ECJ1VB1A105K	1 10V	[M]
C3005	ECJ1VB1A105K	1 10V	[M]
C3006	ECA1HM100B	10 50V	[M]
C3007	ECA1HM100B	10 50V	[M]
C3009	ECA1HM4R7B	4.7 50V	[M]
C5101	ECA1HM100B	10 50V	[M]
C5102	ECJ1VB1C224K	0.22 16V	[M]
C5103	ECJ1VB1C224K	0.22 16V	[M]
C5104	ECJ1VB1H471K	470P 50V	[M]
C5105	ECJ1VB1H471K	470P 50V	[M]
C5106	ECJ1VB1C224K	0.22 16V	[M]
C5107	ECJ1VB1C224K	0.22 16V	[M]
C5108	ECA1CM220B	22 16V	[M]
C5109	ECJ1VB1H104K	0.1 50V	[M]
C5110	ECJ1VB1H104K	0.1 50V	[M]
C5116	ECJ1VB1H104K	0.1 50V	[M]
C5117	ECJ1VB1H104K	0.1 50V	[M]
C5120	ECJ1VB1H221K	220P 50V	[M]
C5121	ECJ1VB1H221K	220P 50V	[M]
C5122	ECJ1VB1H221K	220P 50V	[M]
C5123	ECJ1VB1H221K	220P 50V	[M]
C5124	ECJ1VB1H104K	0.1 50V	[M]
C5201	ECA1HM100B	10 50V	[M]
C5202	ECJ1VB1C224K	0.22 16V	[M]
C5203	ECJ1VB1C224K	0.22 16V	[M]
C5204	ECJ1VB1H471K	470P 50V	[M]
C5205	ECJ1VB1H471K	470P 50V	[M]
C5206	ECJ1VB1C224K	0.22 16V	[M]
C5207	ECJ1VB1C224K	0.22 16V	[M]
C5208	ECA1CM220B	22 16V	[M]
C5210	ECJ1VB1H104K	0.1 50V	[M]
C5211	ECJ1VB1H104K	0.1 50V	[M]
C5216	ECJ1VB1H104K	0.1 50V	[M]
C5217	ECJ1VB1H104K	0.1 50V	[M]
C5220	ECJ1VB1H221K	220P 50V	[M]
C5221	ECJ1VB1H221K	220P 50V	[M]
C5222	ECJ1VB1H221K	220P 50V	[M]
C5223	ECJ1VB1H221K	220P 50V	[M]
C5224	ECJ1VB1H104K	0.1 50V	[M]
C5301	ECA1HM100B	10 50V	[M]
C5302	ECJ1VB1C224K	0.22 16V	[M]
C5303	ECJ1VB1C224K	0.22 16V	[M]
C5304	ECJ1VB1H471K	470P 50V	[M]
C5305	ECJ1VB1H471K	470P 50V	[M]
C5306	ECJ1VB1C224K	0.22 16V	[M]
C5307	ECJ1VB1C224K	0.22 16V	[M]
C5308	ECA1CM220B	22 16V	[M]
C5310	ECJ1VB1H104K	0.1 50V	[M]
C5311	ECJ1VB1H104K	0.1 50V	[M]
C5316	ECJ1VB1H104K	0.1 50V	[M]
C5317	ECJ1VB1H104K	0.1 50V	[M]
C5320	ECJ1VB1H221K	220P 50V	[M]
C5321	ECJ1VB1H221K	220P 50V	[M]
C5322	ECJ1VB1H221K	220P 50V	[M]
C5323	ECJ1VB1H221K	220P 50V	[M]
C5324	ECJ1VB1H104K	0.1 50V	[M]
C5503	ECA1VM102B	1000 35V	[M]
C5505	ECJ1VB1H471K	470P 50V	[M]
C5790	ECJ1VB1H102K	1000P 50V	[M]
C5791	ECA1CM101B	100 16V	[M]
C5792	ECA0JM221B	220 6.3V	[M]
C5794	ECA1CM330B	33 16V	[M]
C5795	ECJ1VB1H104K	0.1 50V	[M]
C5796	ECA1HM2R2B	2.2 50V	[M]
C5797	ECEA1HKA010B	1 50V	[M]
C5798	ECA1HM101B	100 50V	[M]
C5799	ECJ1VB1H104K	0.1 50V	[M]
C6805	ECJ1VC1H101K	100P 50V	[M]
C6806	ECJ1VC1H101K	100P 50V	[M]
C6903	ECA1HM220B	22 50V	[M]
C6904	ECJ1VB1H102K	1000P 50V	[M]
C6905	ECA1HM220B	22 50V	[M]
C6906	ECJ1VC1H101K	100P 50V	[M]

Ref. No.	Part No.	Part Name & Description	Remarks
C6909	ECJ1VB1H103K	0.01 50V	[M]
C6910	ECA0JM101B	100 6.3V	[M]
C6911	ECJ1VB1H103K	0.01 50V	[M]
C6913	ECA1HM3R3B	3.3 50V	[M]
C6916	ECJ1VC1H101K	100P 50V	[M]
C6917	ECJ1VC1H101K	100P 50V	[M]
C6918	ECA1AM470B	47 10V	[M]
C8001	EEE0GA331WP	330P 4V	[M]
C8003	ECJ0EF1C104Z	0.1 16V	[M]
C8004	ECJ0EF1C104Z	0.1 16V	[M]
C8005	ECJ0EF1C104Z	0.1 16V	[M]
C8006	ECJ0EF1C104Z	0.1 16V	[M]
C8007	ECJ0EF1C104Z	0.1 16V	[M]
C8008	ECJ0EF1C104Z	0.1 16V	[M]
C8011	F2G0J101A066	100 6.3V	[M]
C8012	ECJ0EF1C104Z	0.1 16V	[M]
C8013	ECJ0EF1C104Z	0.1 16V	[M]
C8014	ECJ0EF1C104Z	0.1 16V	[M]
C8015	ECJ0EF1C104Z	0.1 16V	[M]
C8016	ECJ0EF1C104Z	0.1 16V	[M]
C8017	ECJ0EF1C104Z	0.1 16V	[M]
C8018	ECJ0EF1C104Z	0.1 16V	[M]
C8019	ECJ0EF1C104Z	0.1 16V	[M]
C8020	ECJ0EF1C104Z	0.1 16V	[M]
C8021	ECJ0EF1C104Z	0.1 16V	[M]
C8022	ECJ0EF1C104Z	0.1 16V	[M]
C8023	ECJ0EF1C104Z	0.1 16V	[M]
C8024	ECJ0EF1C104Z	0.1 16V	[M]
C8025	ECJ0EF1C104Z	0.1 16V	[M]
C8026	ECJ0EF1C104Z	0.1 16V	[M]
C8051	ECJ1VB0J105K	1 6.3V	[M]
C8052	ECJ0EF1C104Z	0.1 16V	[M]
C8053	ECJ0EF1C104Z	0.1 16V	[M]
C8054	ECJ0E1H221J	220P 50V	[M]
C8055	ECJ1VB0J105K	1 6.3V	[M]
C8056	ECJ0EB1E222K	2200P 25V	[M]
C8057	ECJ1VB0J105K	1 6.3V	[M]
C8111	ECJ0EB1A104K	0.1 10V	[M]
C8112	ECJ1VB0J105K	1 6.3V	[M]
C8113	ECJ0EB1E471K	470P 25V	[M]
C8151	ECJ1VB0J475K	4.7 6.3V	[M]
C8152	ECJ1VB1C105K	1 16V	[M]
C8201	F2G0J101A066	100 6.3V	[M]
C8202	ECJ0EB1A104K	0.1 10V	[M]
C8203	ECJ0EB1A104K	0.1 10V	[M]
C8211	ECJ0EB1E122K	1200P 25V	[M]
C8221	ECJ0EB1E102K	1000P 25V	[M]
C8222	ECJ0EB1E821K	820P 25V	[M]
C8225	ECJ0EB1E102K	1000P 25V	[M]
C8226	ECJ0EB1E102K	1000P 25V	[M]
C8231	ECJ0EB1A104K	0.1 10V	[M]
C8232	ECJ0EB1A104K	0.1 10V	[M]
C8251	F2G0J221A065	220 6.3V	[M]
C8252	ECJ0EF1C104Z	0.1 16V	[M]
C8253	ECJ0EF1C104Z	0.1 16V	[M]
C8255	F2G1C220A037	22 16V	[M]
C8256	ECJ0EF1C104Z	0.1 16V	[M]
C8257	F2G1C470A076	47 16V	[M]
C8258	ECJ0EF1C104Z	0.1 16V	[M]
C8261	ECJ0EF1C104Z	0.1 16V	[M]
C8262	ECJ0EF1C104Z	0.1 16V	[M]
C8301	F2G0J221A031	220 6.3V	[M]
C8302	F2G0J330A031	33 6.3V	[M]
C8303	ECJ0EB1A104K	0.1 10V	[M]
C8304	ECJ0EB1A104K	0.1 10V	[M]
C8305	ECJ0EB1A104K	0.1 10V	[M]
C8306	ECJ0EB1A104K	0.1 10V	[M]
C8311	ECJ0EB1A104K	0.1 10V	[M]
C8312	ECJ1VB0J105K	1 6.3V	[M]
C8313	ECJ1VB0J105K	1 6.3V	[M]
C8325	ECJ0EF1C104Z	0.1 16V	[M]
C8331	ECJ0EF1C104Z	0.1 16V	[M]
C8401	ECJ0E1H150J	15P 50V	[M]

Ref. No.	Part No.	Part Name & Description	Remarks
C8421	F2G0J101A083	100 6.3V	[M]
C8422	ECJOEF1C104Z	0.1 16V	[M]
C8423	F2G0J330A083	33 6.3V	[M]
C8424	ECJOEF1C104Z	0.1 16V	[M]
C8426	ECJOEF1C104Z	0.1 16V	[M]
C8427	ECJOEF1C104Z	0.1 16V	[M]
C8428	ECJOEF1C104Z	0.1 16V	[M]
C8501	F2G0J101A031	100 6.3V	[M]
C8502	ECJOEF1C104Z	0.1 16V	[M]
C8503	ECJOEF1C104Z	0.1 16V	[M]
C8504	ECJOEF1C104Z	0.1 16V	[M]
C8505	ECJOEF1C104Z	0.1 16V	[M]
C8511	ECJ1VB0J105K	1 6.3V	[M]
C8512	ECJ1VB0J105K	1 6.3V	[M]
C8513	ECJOEB1A104K	0.1 10V	[M]
C8514	ECJOEB1A104K	0.1 10V	[M]
C8515	ECJOEB1A104K	0.1 10V	[M]
C8516	ECJOEB1A104K	0.1 10V	[M]
C8521	ECJOEB1A104K	0.1 10V	[M]
C8522	ECJOEB1A104K	0.1 10V	[M]
C8523	ECJOEF1C104Z	0.1 16V	[M]
C8524	ECJOEF1C104Z	0.1 16V	[M]
C8525	ECJOEB1C562K	5600P 16V	[M]
C8526	ECJOEB1C183K	0.018 16V	[M]
C8527	ECJOEB1A333K	0.033 10V	[M]
C8528	ECJ1VB0J105K	1 6.3V	[M]
C8529	ECJ1VB0J105K	1 6.3V	[M]
C8530	ECJOEF1C104Z	0.1 16V	[M]
C8531	ECJOEC1H101J	100P 50V	[M]
C8532	ECJOEC1H221J	220P 50V	[M]
C8533	ECJOEF1C104Z	0.1 16V	[M]
C8541	ECJOEB1E472K	4700P 25V	[M]
C8550	F2G0J330A031	33 6.3V	[M]
C8551	ECJOEF1C104Z	0.1 16V	[M]
C8552	F2G1C100A072	10 16V	[M]
C8553	F2G0J470A031	47 6.3V	[M]
C8554	ECJ1VB0J105K	1 6.3V	[M]
C8561	ECJOEF1C104Z	0.1 16V	[M]
C8562	F2G1C100A072	10 16V	[M]
C8563	F2G0J470A031	47 6.3V	[M]
C8564	ECJ1VB0J105K	1 6.3V	[M]
C8571	ECJ3YB1A106M	10 10V	[M]
C8572	ECJOEF1C104Z	0.1 16V	[M]
C8601	ECJOEF1C104Z	0.1 16V	[M]
C8602	ECJOEB1C153K	0.015 16V	[M]
C8606	ECJOEF1C104Z	0.1 16V	[M]
C8611	ECJOEF1C104Z	0.1 16V	[M]
C8621	ECJOEC1H120J	12P 50V	[M]
C8622	ECJOEC1H120J	12P 50V	[M]
C8651	ECJOEF1C104Z	0.1 16V	[M]
C8652	ECJOEF1C104Z	0.1 16V	[M]
C8691	ECJOEF1C104Z	0.1 16V	[M]
C8695	ECJOEF1C104Z	0.1 16V	[M]