

# Service Manual

COMPACT  
**disc**  
DIGITAL AUDIO

**DIGITAL**

**MASH**<sup>\*</sup>  
multi-stage noise shaping

**DOLBY SYSTEM**<sup>\*</sup>

CD Stereo System

## SA-LS10

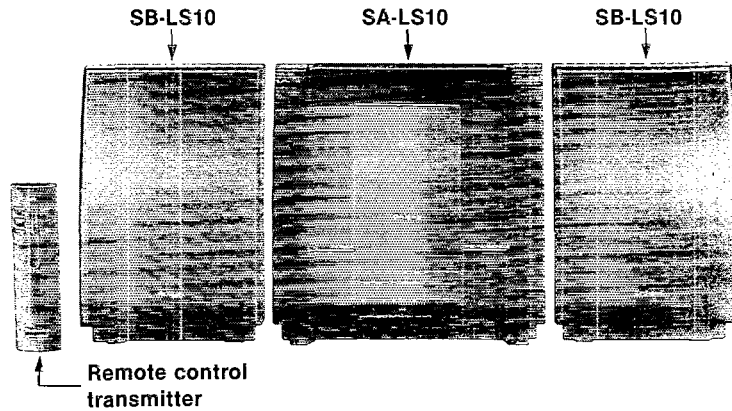

Colour

(K) ... Black Type

Area

Suffix for Model No.	Area	Colour
(EB)	Great Britain.	(K)
(EG)	Europe.	
(EI)	Italy.	

System: SC-LS10

\* Dolby noise reduction manufactured under license from Dolby Laboratories Licensing Corporation. "Dolby" and the double-D symbol are trade marks of Dolby Laboratories Licensing Corporation.

※ • MASH is a trademark of NTT.

TAPE DECK: AR-1 MECHANISM SERIES

TRAVERSE DECK: RAE0135Z MECHANISM SERIES

### SPECIFICATIONS (DIN 45 500)

#### ■ AMPLIFIER SECTION

40 Hz–16 kHz continuous output both channels driven	2 × 15 W (THD 1%, 4Ω)
1 kHz continuous power output both channels driven	2 × 20 W (THD 1%, 4Ω)
Total harmonic distortion half power at 1 kHz	0.09% (4Ω)
Input sensitivity	
AUX	250 mV
Input impedance	
AUX	22 kΩ

#### ■ FM TUNER SECTION

Frequency range	87.50–108.00 MHz
Sensitivity	1.8 μV (IHF '58)
S/N 26 dB	1.5 μV
S/N	
MONO	70 dB (75 dB, IHF)
Image rejection at 98 MHz	80 dB
Alternate channel selectivity	±400 kHz, 65 dB
Stereo separation	
1 kHz	35 dB
Antenna terminal(s)	75Ω (unbalanced)

#### ■ AM TUNER SECTION

Frequency range	
MW	522–1611 kHz (9 kHz steps)
LW	530–1620 kHz (10 kHz steps)
LW	144–288 kHz (9 kHz steps)
Sensitivity (S/N 20 dB)	
MW (at 999 kHz, 1000 kHz)	500 μV/m
LW (at 216 kHz)	50 μV

#### ■ CASSETTE DECK SECTION

Track system	4-track, 2-channel
Heads	
Record/playback	Permalloy head
Erasure	Double gap ferrite head
Motor	DC servo motor
Recording system	AC bias, 100 kHz
Erase system	AC erase
Tape speed	4.8 cm/s (1-7/8 ips)
Frequency response	
Normal	40 Hz–14 kHz
CrO <sub>2</sub>	40 Hz–14 kHz
Metal	40 Hz–15 kHz
S/N(CrO <sub>2</sub> type tape)	
Dolby NR off	52 dB (A-WTD)
Dolby NR on	61 dB (CCIR)
Wow and flutter	0.1% (WRMS)
Fast forward and rewind time	

Approx. 45 seconds with C-60 cassette tape

#### △ WARNING

This service information is designed for experienced repair technicians only and is not designed for use by the general public. It does not contain warnings or cautions to advise non-technical individuals of potential dangers in attempting to service a product. Products powered by electricity should be serviced or repaired only by experienced professional technicians. Any attempt to service or repair the product or products dealt with in this service information by anyone else could result in serious injury or death.

# Technics<sup>®</sup>

© 1994 Matsushita Electric Industrial Co., Ltd.  
All rights reserved. Unauthorized copying and distribution is a violation of law.

**CD SECTION**

Sampling frequency	44.1 kHz
Decoding	16-bit linear
Beam source	Semiconductor laser
Wave length	780 nm
Number of channels	Stereo
S/N	85 dB
Wow and flutter	Below measurable limit
Digital filter	8 fs
D/A converter	MASH (1 BIT DAC)

**GENERAL**

Power consumption	77 W 5 W (with standby mode)
Power supply	AC 50/60 Hz, 230 V
[For (EG, EI) areas.]	AC 50/60 Hz, 230/240 V
[For (EB) area.]	300 × 314 × 197 mm (11 <sup>13</sup> / <sub>16</sub> " × 12 <sup>3</sup> / <sub>8</sub> " × 7 <sup>3</sup> / <sub>4</sub> " )
Dimensions (W × H × D)	5.5 kg (12.1 lb.)
Weight	

**Notes:**

- Specifications are subject to change without notice. Weight and dimensions are approximate.
- Total harmonic distortion is measured by the digital spectrum analyzer.

**CONTENTS**

	Page
PROTECTION CIRCUITRY.....	2
PRECAUTION OF LASER DIODE.....	3
CAUTION FOR AC MAINS LEAD.....	4
BEFORE REPAIR AND ADJUSTMENT.....	4
FRONT PANEL CONTROLS.....	5, 6
CONCERNING THE REMOTE CONTROL.....	6, 7
CONNECTIONS.....	7~10
ACCESSORIES.....	10
SETTING THE TIME.....	11
MEMORY PRESETTING.....	11~13
LISTENING TO COMPACT DISCS.....	13~16
LISTENING TO TAPES.....	16, 17
LISTENING TO RADIO BROADCASTS.....	17~19
LISTENING WITH SOUNDSCAPE.....	19, 20
CHANGING SOUND QUALITY AND FIELD.....	20
RECORDING COMPACT DISCS.....	21~24
RECORDING FROM RADIO BROADCASTS.....	24, 25
USING THE TIMER.....	26~29
LISTENING TO AN EXTERNAL SOURCE OR WITH HEADPHONES.....	29, 30
MAINTENANCE.....	30
QUICK REFERENCE OF REMOTE CONTROL OPERATIONS.....	31
SELF-DIAGNOSTIC FUNCTION.....	32, 33
SOUNDSCAPE.....	34, 35
HANDLING PRECAUTIONS FOR TRAVERSE DECK.....	36
OPERATION CHECKS AND MAIN COMPONENT REPLACEMENT PROCEDURES.....	37
CHECKING PROCEDURE FOR EACH P.C.B.....	38~42
MAIN COMPONENT REPLACEMENT PROCEDURES.....	42~48

	Page
MEASUREMENTS AND ADJUSTMENTS.....	49~52
NEW DIGITAL SERVO CIRCUIT.....	52
TROUBLESHOOTING GUIDE.....	53, 54
TERMINAL FUNCTION OF IC'S.....	55~60
BLOCK DIAGRAM.....	61~66
SCHEMATIC DIAGRAM.....	67~83
TUNER CIRCUIT.....	68, 69
SERVO CIRCUIT.....	70, 71
LOADING MOTOR CIRCUIT.....	72
SWITCH CIRCUIT.....	72
MECHANISM CONTROL CIRCUIT.....	73, 74
MECHANISM CIRCUIT.....	74
OPERATION CIRCUIT.....	75
SENSOR CIRCUIT.....	75
FL CIRCUIT.....	75~77
MAIN CIRCUIT.....	78~82
POWER SUPPLY CIRCUIT.....	78, 83
CONNECTOR CIRCUIT.....	78
SPEAKER TERMINAL CIRCUIT.....	83
HEADPHONES JACK CIRCUIT.....	83
POWER TRANSFORMER CIRCUIT.....	83
PRINTED CIRCUIT BOARDS.....	84~90
WIRING CONNECTION DIAGRAM.....	91, 92
TERMINAL GUIDE OF IC'S, TRANSISTORS AND DIODES.....	93
REPLACEMENT PARTS LIST.....	94~98, 103, 108
CABINET PARTS LOCATION.....	99, 100
MECHANISM PARTS LOCATION.....	101, 102
RESISTORS AND CAPACITORS.....	103~107
PACKAGING.....	108

**PROTECTION CIRCUITRY**

The protection circuitry may have operated if either of the following conditions is noticed:

- No sound is heard when the power is turned on.
- Sound stops during a performance.

The function of this circuitry is to prevent circuitry damage if, for example, the positive and negative speaker connection wires are "shorted", or if speaker systems with an impedance less than the indicated rated impedance of the amplifier are used.

If this occurs, follow the procedure outlines below:

1. Turn off the power.
2. Determine the cause of the problem and correct it.
3. Turn on the power once again after one minute.

**Note:**

When the protection circuitry functions, the unit will not operate unless the power is first turned off and then on again.

## PRECAUTION OF LASER DIODE

**CAUTION:** This product utilizes a laser diode with the unit turned "on", invisible laser radiation is emitted from the pickup lens.

Wave length: 780nm

Maximum output radiation power from pickup: 100 $\mu$ W/VDE

Laser radiation from the pickup lens is safety level, but be sure the followings:

1. Do not disassemble the optical pickup unit, since radiation from exposed laser diode is dangerous.
2. Do not adjust the variable resistor on the pickup unit. It was already adjusted.
3. Do not look at the focus lens using optical instruments.
4. Recommend not to look at pickup lens for a long time.

**ACHTUNG:** Dieses Produkt enthält eine Laserdiode. Im eingeschalteten Zustand wird unsichtbare Laserstrahlung von der Lasereinheit abgestrahlt.

Wellenlänge: 780nm

Maximale Strahlungsleistung der Lasereinheit: 100 $\mu$ W/VDE

Die Strahlung an der Lasereinheit ist ungefährlich, wenn folgende Punkte beachtet werden:

1. Die Lasereinheit nicht zerlegen, da die Strahlung an der freigelegten Laserdiode gefährlich ist.
2. Den werkseitig justierten Einstellregler der Lasereinheit nicht verstellen.
3. Nicht mit optischen Instrumenten in die Fokussierlinse blicken.
4. Nicht über längere Zeit in die Fokussierlinse blicken.

**ADVARSEL:** I dette a apparat anvendes laser.

(Printed in the rear panel)



LUOKAN 1 LASERLAITE  
KLASS 1 LASER APPARAT

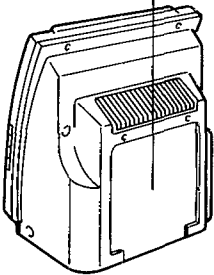

RQLS0024



RQLS0078

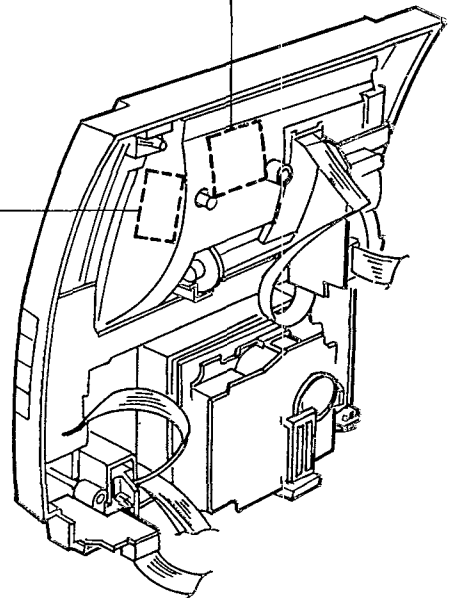
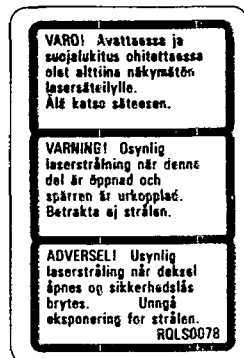



## CAUTION FOR AC MAINS LEAD

### [For (EB) area.]

For your safety, please read the following text carefully.

This appliance is supplied with a moulded three pin mains plug for your safety and convenience.

A 5-ampere fuse is fitted in this plug.

Should the fuse need to be replaced please ensure that the replacement fuse has a rating of 5-ampere and that it is approved by ASTA or BSI to BS1362. Check for the ASTA mark  or the BSI mark  on the body of the fuse.

If the plug contains a removable fuse cover you must ensure that it is refitted when the fuse is replaced.

If you lose the fuse cover the plug must not be used until a replacement cover is obtained.

A replacement fuse cover can be purchased from your local dealer.

### CAUTION!

IF THE FITTED MOULDED PLUG IS UNSUITABLE FOR THE SOCKET OUTLET IN YOUR HOME THEN THE FUSE SHOULD BE REMOVED AND THE PLUG CUT OFF AND DISPOSED OF SAFELY.

THERE IS A DANGER OF SEVERE ELECTRICAL SHOCK IF THE CUT OFF PLUG IS INSERTED INTO ANY 13-AMPERE SOCKET.

If a new plug is to be fitted please observe the wiring code as shown below.

If in any doubt please consult a qualified electrician.

### IMPORTANT

The wires in this mains lead are coloured in accordance with the following code:

Blue: Neutral

Brown: Live

As the colours of the wires in the mains lead of this appliance may not correspond with the coloured markings identifying the terminals in your plug, proceed as follows:

The wire which is coloured BLUE must be connected to the terminal in the plug which is marked with the letter N or coloured BLACK.

The wire which is coloured BROWN must be connected to the terminal in the plug which is marked with the letter L or coloured RED.

Under no circumstances should either of these wires be connected to the earth terminal of the three pin plug, marked with the letter E or the Earth Symbol .

### Before use

Remove the connector cover as follows.

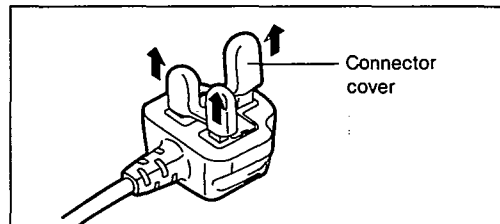

### How to replace the fuse

1. Remove the fuse cover with a screwdriver.

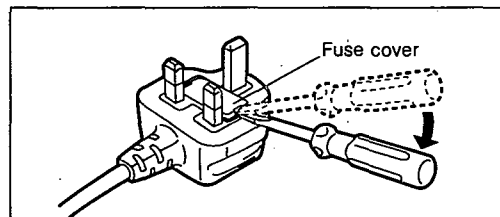

2. Replace the fuse and attach the fuse cover

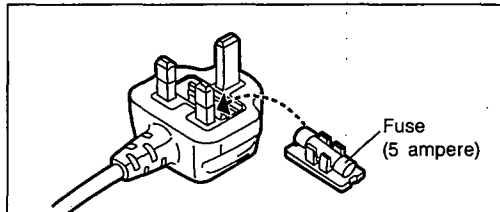

## BEFORE REPAIR AND ADJUSTMENT

Disconnect AC power, Discharge both Power Supply Capacitors C701~703 4700 $\mu$ F through a 10 $\Omega$ , 5W resistor to ground. DO NOT SHORT-CIRCUIT DIRECTLY (with a screwdriver blade, for instance), as this may destroy solid state devices. After repairs are completed, restore power gradually using a variac, to avoid overcurrent.

Current consumption at 50Hz/60Hz in NO SIGNAL mode should be shown below with respect to supply voltage AC 230V/240V.

Power supply voltage	AC 230V		AC 240V	
	Consumed current 50/60Hz	50 Hz	60~180mA	50 Hz
	60 Hz	48~144mA	60 Hz	40~136mA

## FRONT PANEL CONTROLS

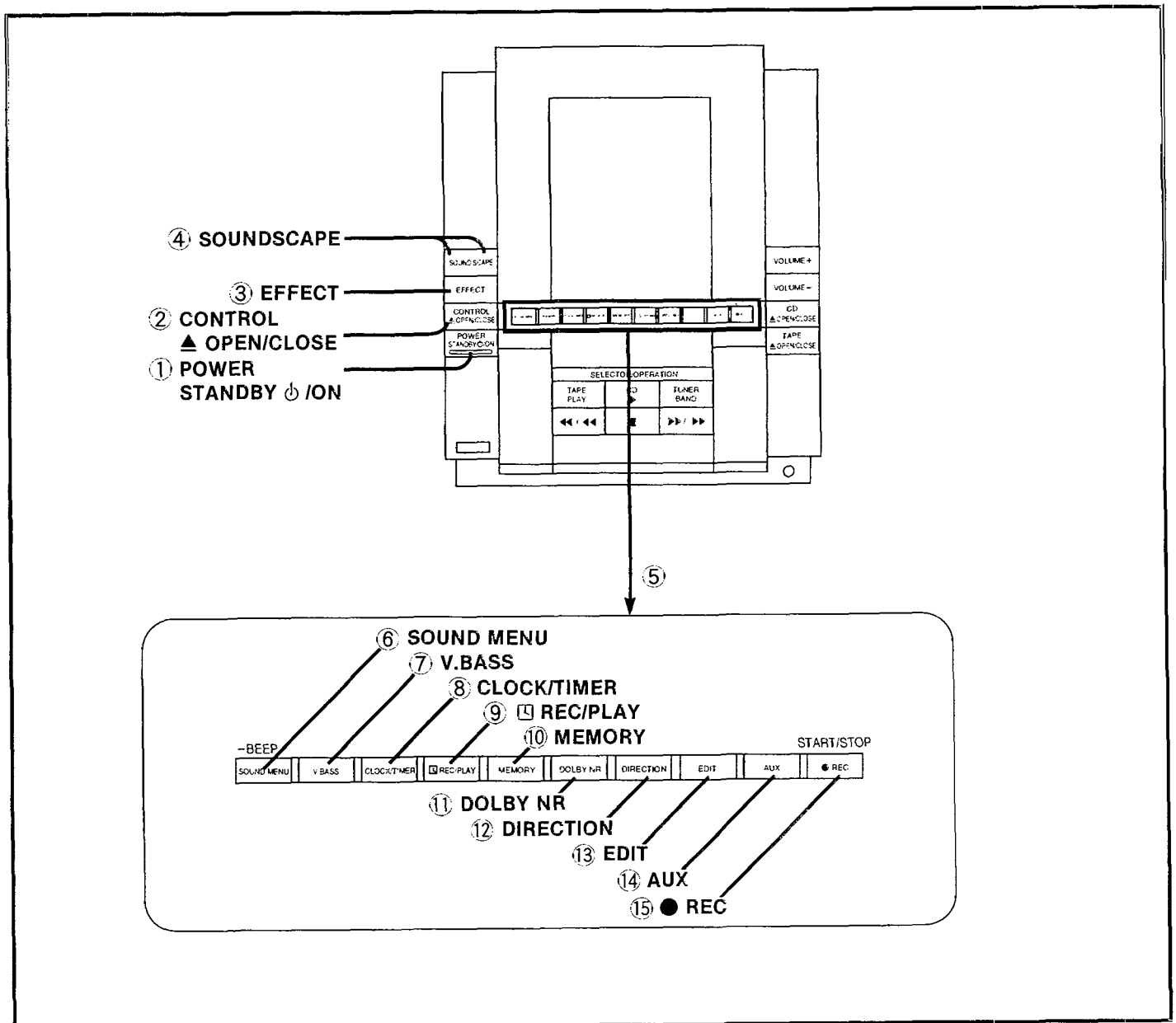

The control panel ⑤ can be accessed by pressing the following two buttons in the designated order.

1. POWER STANDBY  $\phi$  /ON switch
2. CONTROL  $\blacktriangle$  OPEN/CLOSE button

The front panel will open, exposing the control panel.

① **Power "STANDBY  $\phi$  /ON" switch (POWER, STANDBY  $\phi$  /ON)**

Press to switch the unit from on to standby mode or vice versa. In standby mode, the unit is still consuming a small amount of power.

② **Control panel open/close button**

③ **Soundscape effect adjust button**

④ **Soundscape select button/indicator**

⑤ **Control panel**

⑥ **Sound menu select/beep OFF ON button**

⑦ **V.bass select button**

⑧ **Clock/timer set button**

⑨ **Timer recording/playback button**

⑩ **Memory button**

⑪ **Dolby noise reduction button**

⑫ **Tape direction select button**

⑬ **CD edit-recording button**

⑭ **Auxiliary input button**

⑮ **Record button**

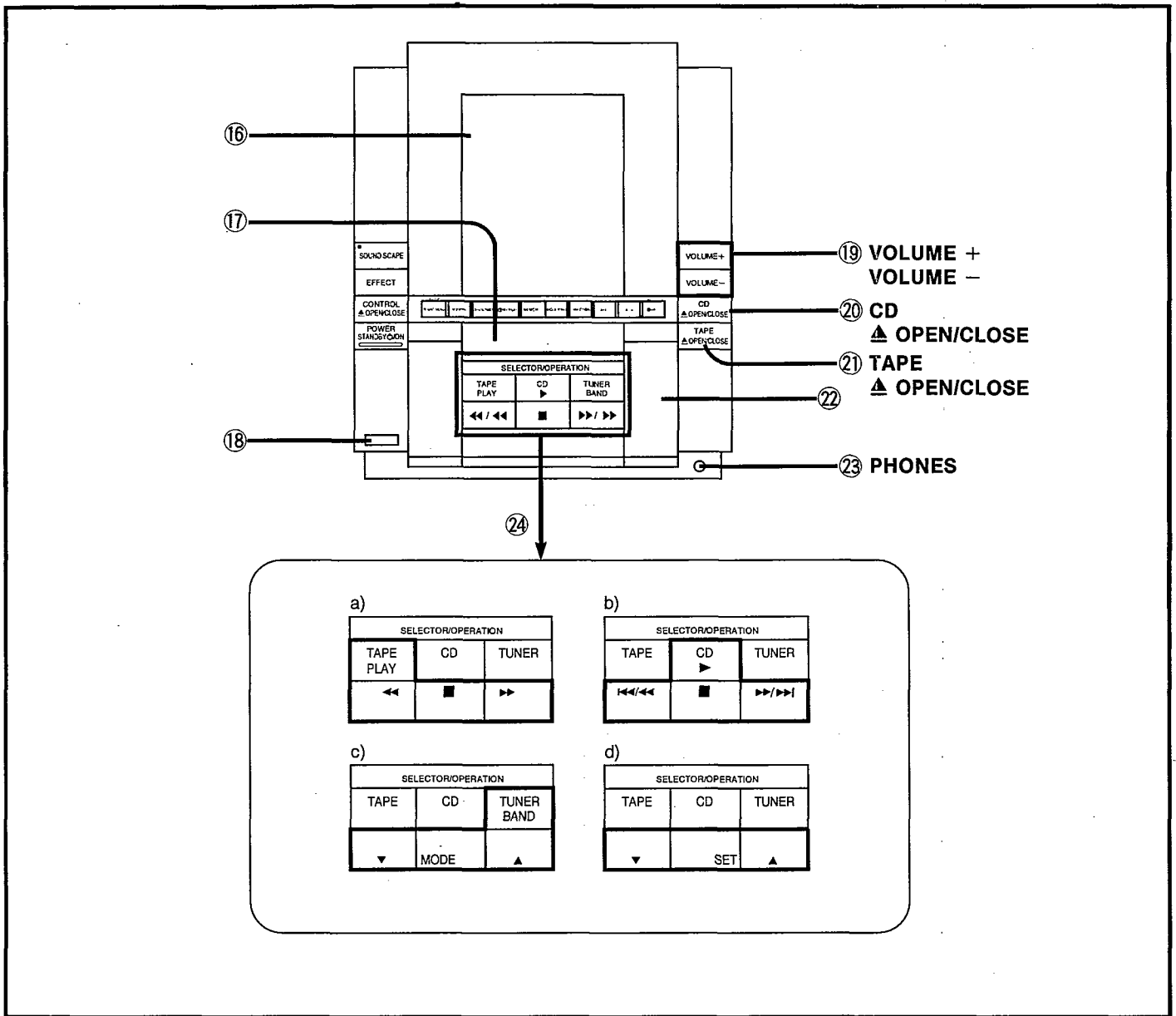

①⑥ Front panel

①⑦ Display

①⑧ Remote control signal receptor

①⑨ Volume controls

②⑩ Front panel open/close button

②① Cassette holder open/close button

②② Cassette holder

②③ Headphones jack

②④ Selector/operation buttons

Button function and indication will change every time the source (TAPE, CD, TUNER) is changed, or when the clock/timer set mode is engaged.

a) When TAPE is set as the source

b) When CD is set as the source

c) When TUNER is set as the source

d) When the clock/timer set mode is engaged

## ■ CONCERNING THE REMOTE CONTROL

### Battery installation **A**

**1** Open the cover.

Slide the cover in the direction of the arrow until it comes off completely.

**2** Insert the batteries in the correct direction ( ⊕, ⊖ )

**3** Close the cover.

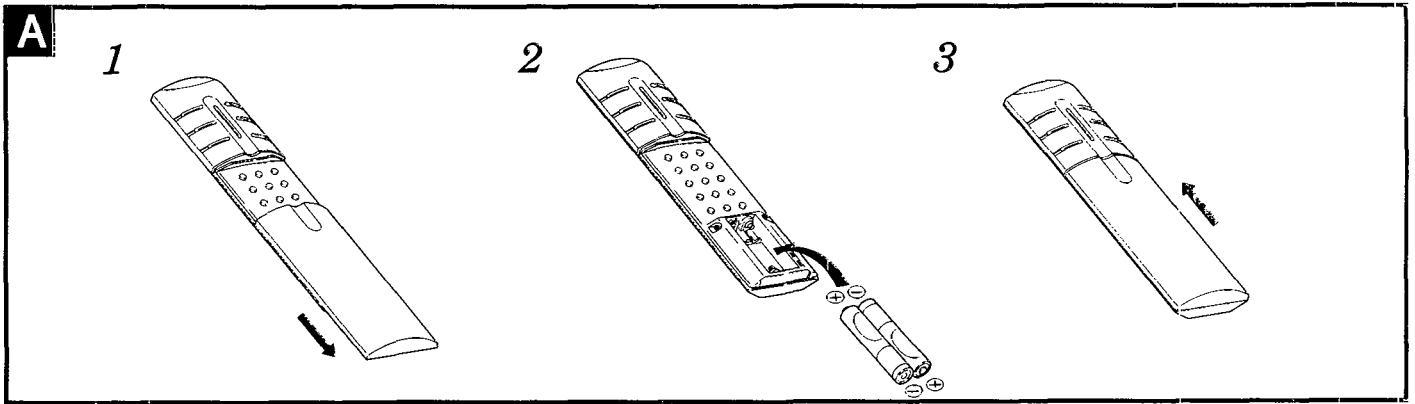

### Use of batteries

- Do not mix old and new batteries, or batteries of different types (carbon, alkaline, etc.).
- Never subject batteries to excessive heat or flame; do not attempt to disassemble them; and be sure they are not short-circuited.
- If the remote control is not to be used for a long period of time, remove the batteries and store them in a cool, dark place.
- Do not attempt to recharge alkaline or carbon batteries.

### Battery life

Battery life is about one year.

The batteries should be replaced if the system fails to respond to commands from the remote control transmitter even when held close to the remote control signal receptor.

### When you need to replace these batteries

Use two UM-4, "AAA", IEC R03 (1.5 V) or equivalent batteries.

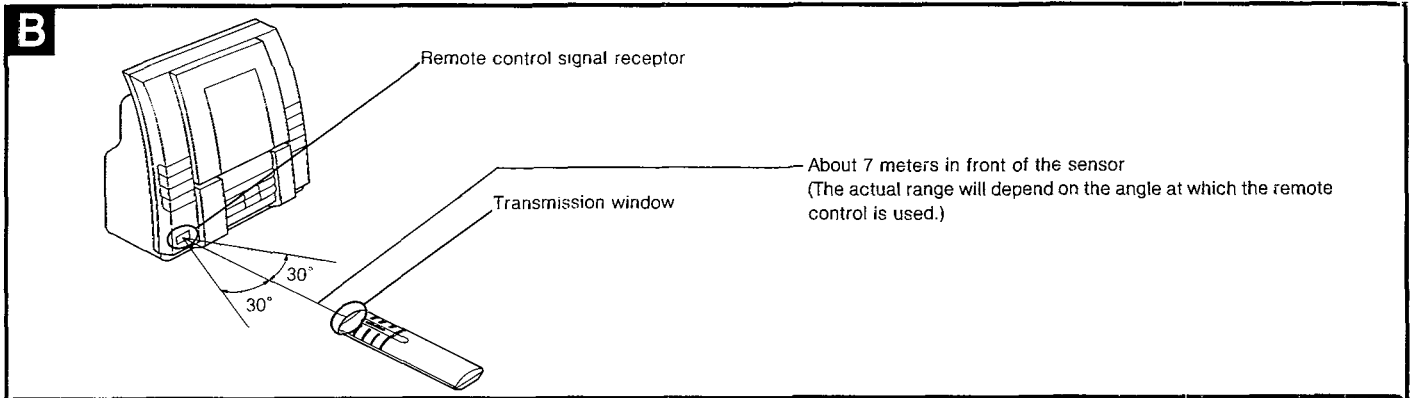

### Correct method of use **B**

#### Operation notes

- Aim the remote control's transmission window toward the unit's sensor. Avoid any obstacles.
- Be sure the transmission window and the unit's sensor are free from dust. Excessive dust might affect performance.
- Do not expose the remote control signal receptor to direct sunlight or to the bright light of an inverter fluorescent light.

## CONNECTIONS

### Precautions in choosing where to put your stereo

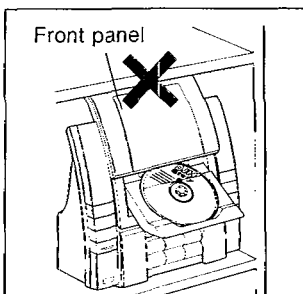

Keep no less than 10 cm of space above your stereo. Any less will prevent the front panel from fully opening and may possibly result in damage to parts.

### Speaker connection

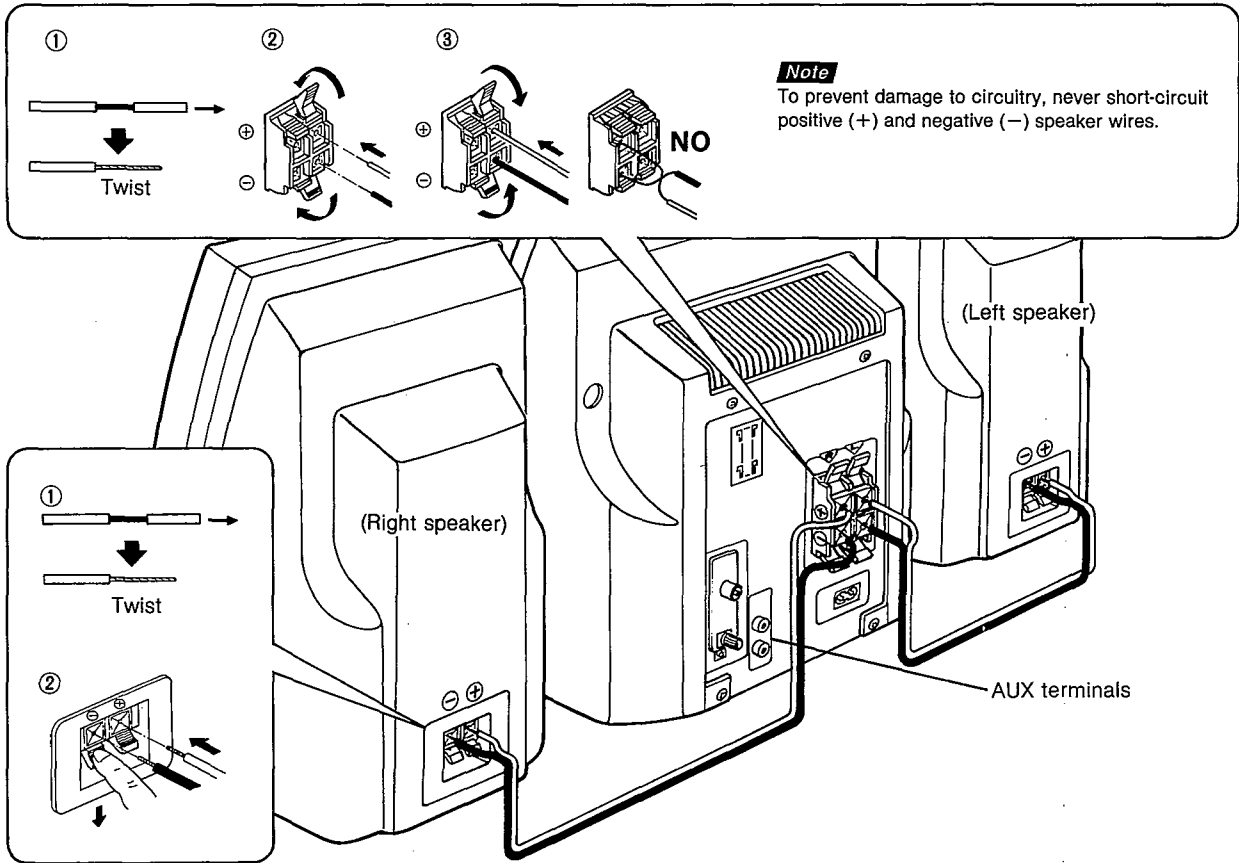

### Antenna and power supply cord connections

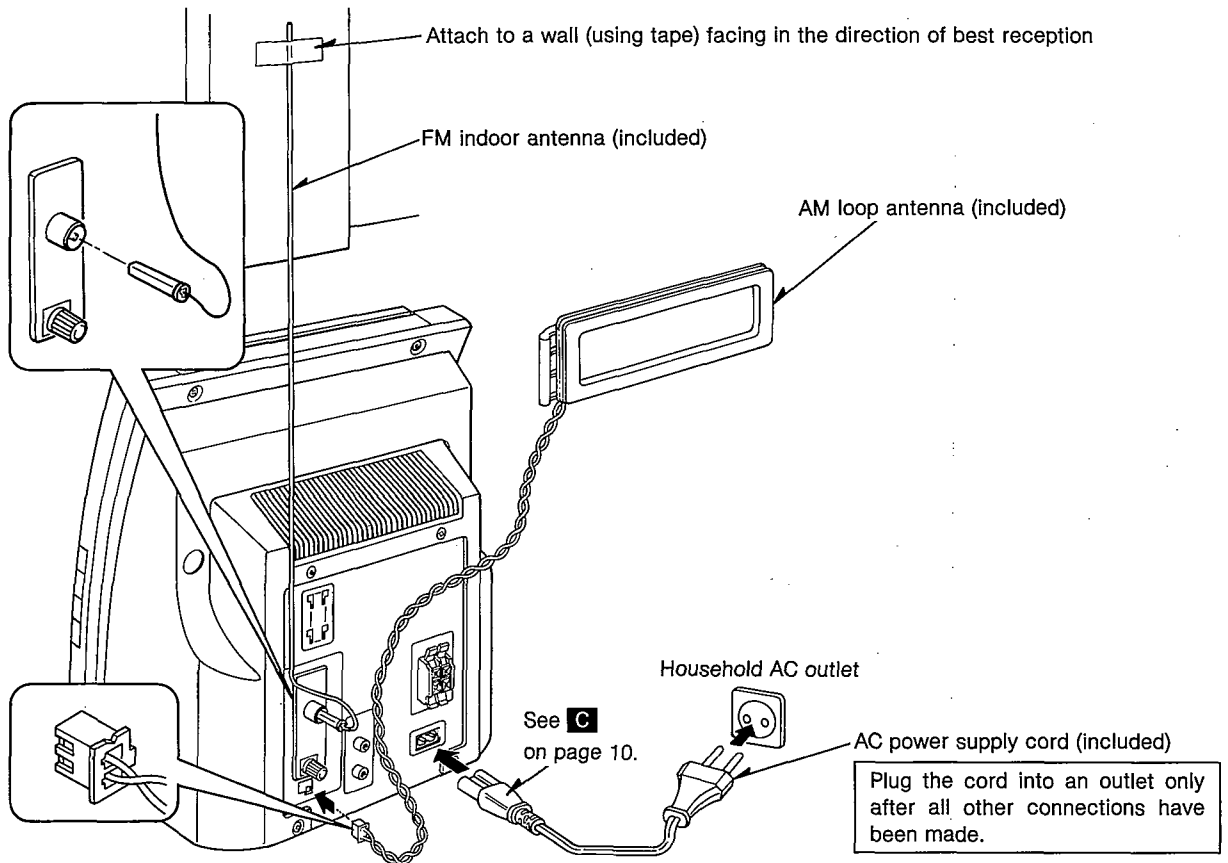



## How to install the AM loop antenna

### • When mounting the antenna to this unit

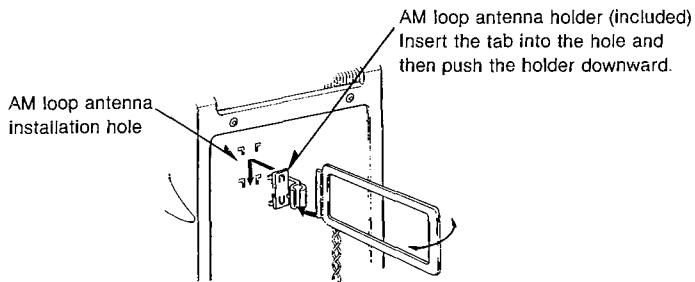

### • When mounting the antenna to a column or rack

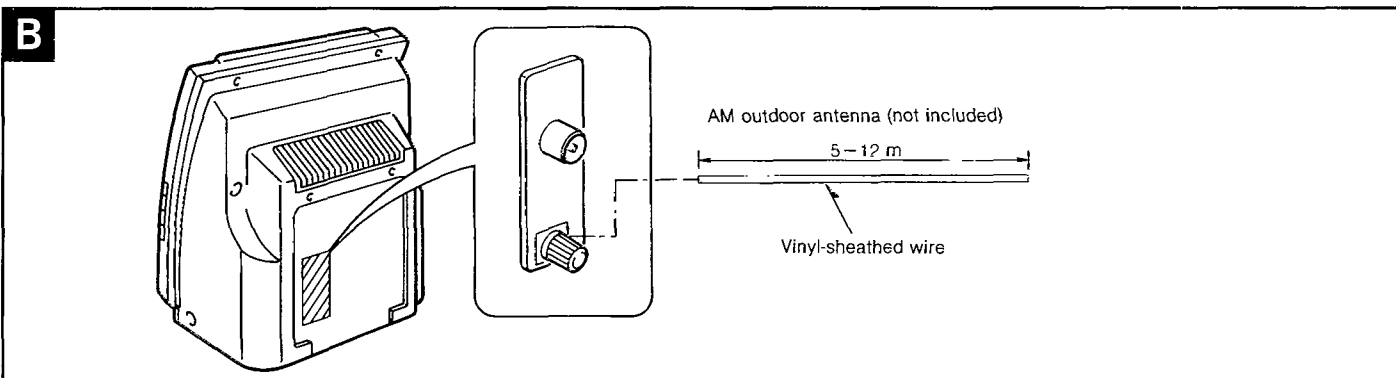
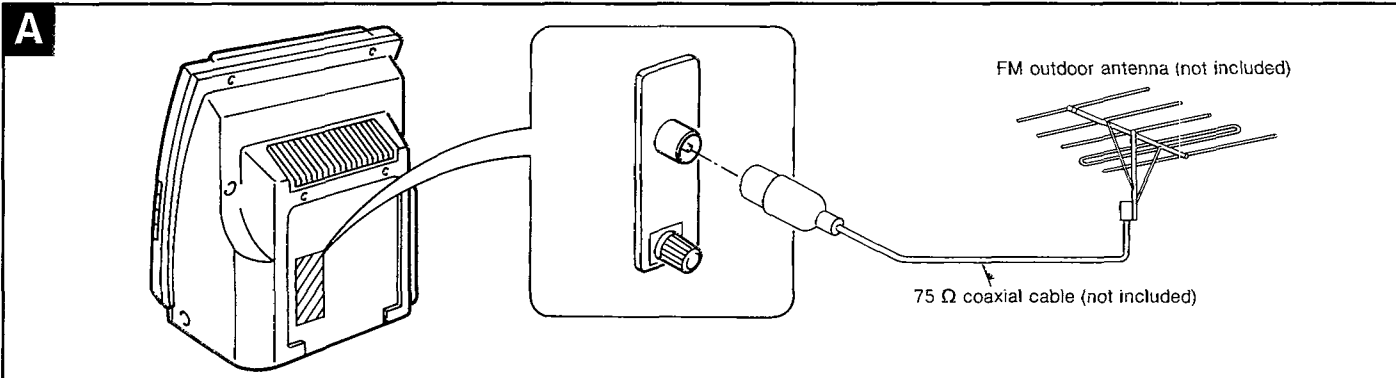
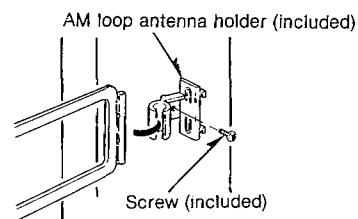

## Optional antenna connections

### FM outdoor antenna (not included) **A**

The outdoor antenna should be used when using this unit in mountainous areas or in spaces enclosed by reinforced concrete where the FM indoor antenna (included) does not provide satisfactory reception.

**Note**

An outdoor antenna should be installed by a qualified technician only.

### AM (MW/LW) outdoor antenna (not included) **B**

The outdoor antenna should be used when using this unit in mountainous areas or in spaces enclosed by reinforced concrete where the AM loop antenna (included) does not provide satisfactory reception.

Use 5-12 m of vinyl-sheathed wire horizontally at the window, or a convenient location.

When the unit is not in use, disconnect the outdoor antenna to prevent possible damage from lightning. Never use an outdoor antenna during an electrical storm.

**Note**

Be sure to connect the AM loop antenna even when an outdoor antenna is used.

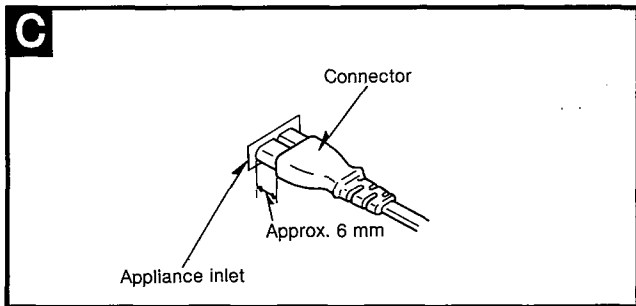

### Insertion of Connector **C**

Even when the connector is perfectly inserted, depending on the type of inlet used, the front part of the connector may jut out as shown in the drawing.

However there is no problem using the unit.

## ACCESSORIES

	<p>AC power supply cord ..... 1 pc.                      [For (EG, EI) areas.]                      (RJA0019-2K)                      [For (EB) area.]                      (VJA0733)</p>
	<p>FM indoor antenna ..... 1 pc.                      (RSA0007)</p>
	<p>Speaker cord ..... 2 pcs.                      (REE0499)</p>
	<p>AM loop antenna set ..... 1 pc.                      (RSA0010)                      • AM loop antenna holder ..... 1 pc.                      (RMN0244)                      • Screw ..... 1 pc.                      (XTN3 + 10AFZ)</p>
	<p>Remote control transmitter ..... 1 pc.                      (EUR642521)</p>
	<p>Batteries for remote control transmitter ..... 2 pcs.                      ("AAA", R03)   <b>Note:</b> These are available on sale route.</p>
	<p>Attachment plug ..... 1 pc.                      [For (EB) area.]                      (SJP9009)</p>

## SETTING THE TIME

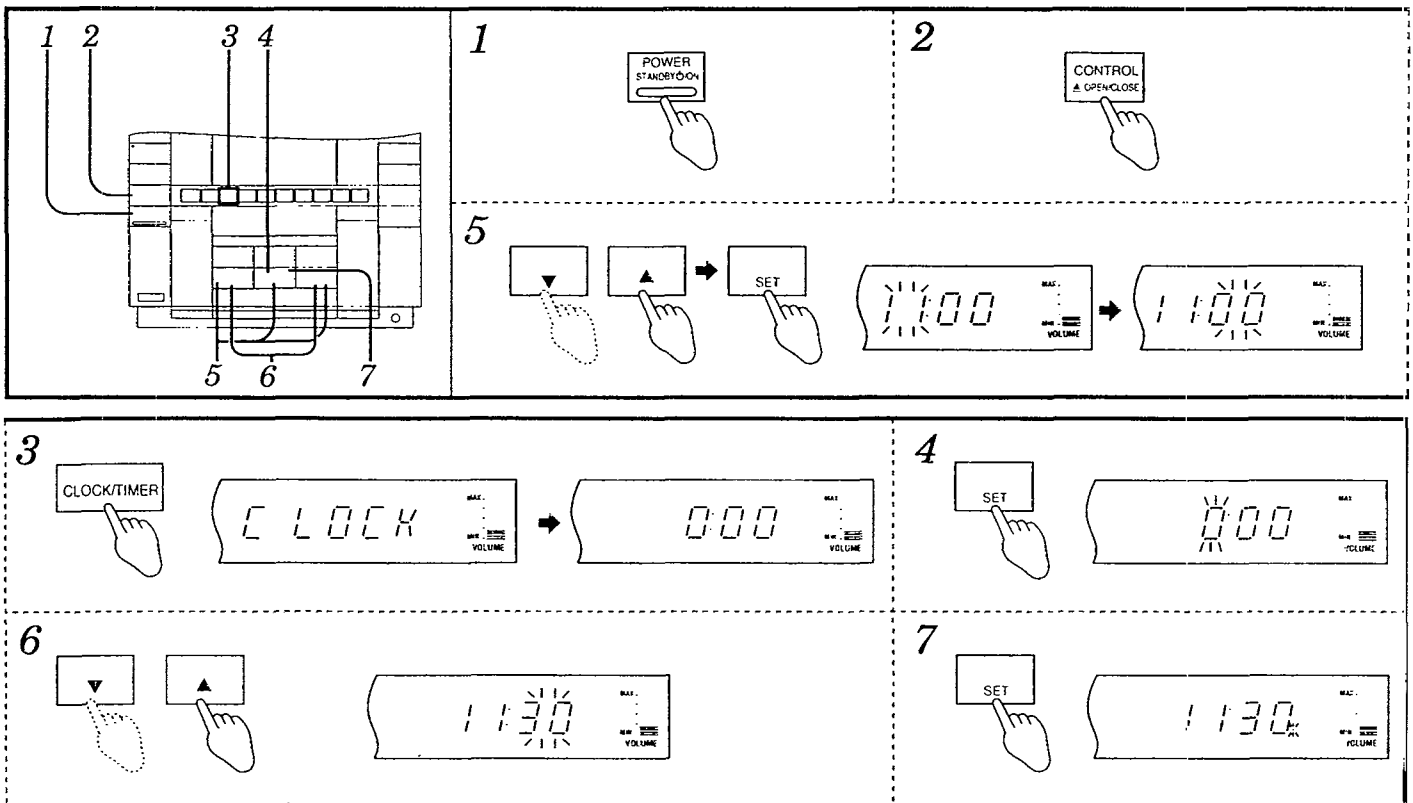

This equipment comes with a 24 hour digital clock.

These instructions explain how to set the timer for 11:30.

**1 Press POWER.**

**2 Press CONTROL  $\blacktriangle$  OPEN/CLOSE.**

The front panel will open, exposing the control panel.

**3 Press CLOCK/TIMER to select "CLOCK".**

Each time the button is pressed, the indication will change as follows.

CLOCK  $\rightarrow$  [ ] PLAY  $\rightarrow$  [ ] REC  
 $\uparrow$   $\downarrow$   
 OFF  $\leftarrow$   $\rightarrow$  SLEEP

**4 Press SET within 10 seconds from when "CLOCK" is displayed.**

**Note**

Unless SET is pressed within 10 seconds, the display will revert back to the indication shown before CLOCK/TIMER was pressed. In such case, begin again from step 3.

**5 Set the hour with  $\blacktriangledown$  and  $\blacktriangle$ , and press SET.**

**6 Set the minutes with  $\blacktriangledown$  and  $\blacktriangle$ .**

The hour indication will not change when the minutes pass from "59" to "00".

**7 Press SET to start the clock.**

The display will return to the previous indication in about 2 seconds.

**To display the clock again**

Press CLOCK/TIMER to select "CLOCK".

The time indication will revert back to the initial display in about 10 seconds.

**"0:00" flashes on the display**

It appears when you connect the power supply cord for the first time or if there has been a power failure.

If this happens, reset the time.

## MEMORY PRESETTING

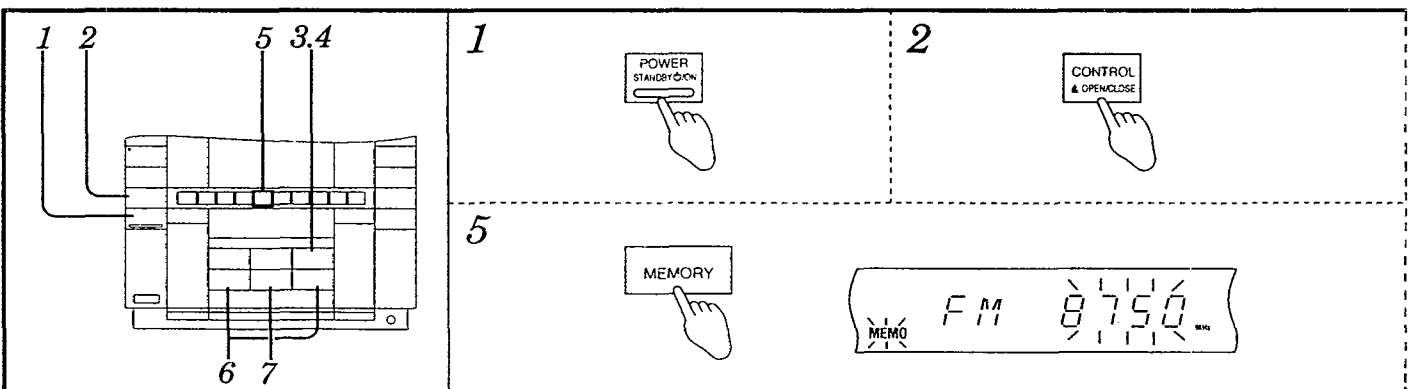

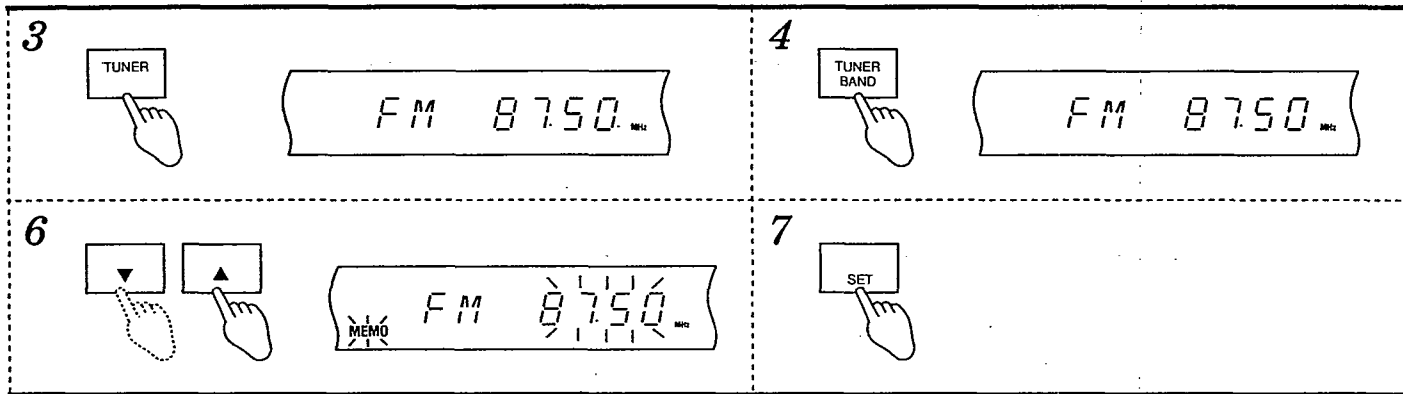

Radio stations can be easily picked up from the stereo itself or by remote control, when their frequencies have been stored in memory. Up to 12 stations can be memorized for each FM, MW and LW bands. Stations can be memorized both manually and automatically.

**Memory presetting-AUTOMATIC**

This example shows how to memorize FM stations.

- 1 Press POWER.
- 2 Press CONTROL ▲ OPEN/CLOSE.  
The front panel will open, exposing the control panel.
- 3 Press TUNER.
- 4 Press TUNER BAND to select "FM" ("MW" or "LW").

**Note**

Each time the button is pressed, the indication will change as follows.

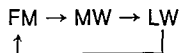

- 5 Press MEMORY.
- 6 Set the frequency from which you want to start automatic memory presetting with ▼ and ▲.
- 7 Hold down SET for 2 seconds and release it when the frequency begins to scroll.  
(This will start automatic memorization.)

To stop auto memorization in progress, press MEMORY.

The moment the frequency is memorized  
The station and channel will be displayed for about 1 second.

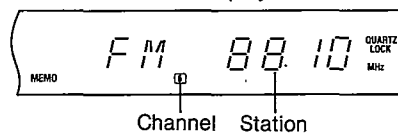

When auto memorization is complete  
The last station to be memorized will be left on the display.

To check the memorized stations  
Press ▼ and ▲.

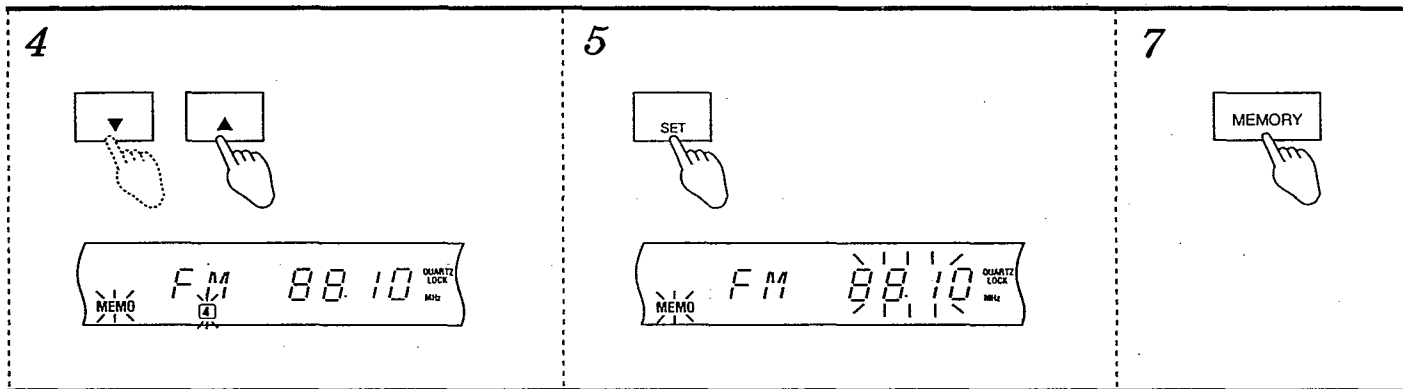
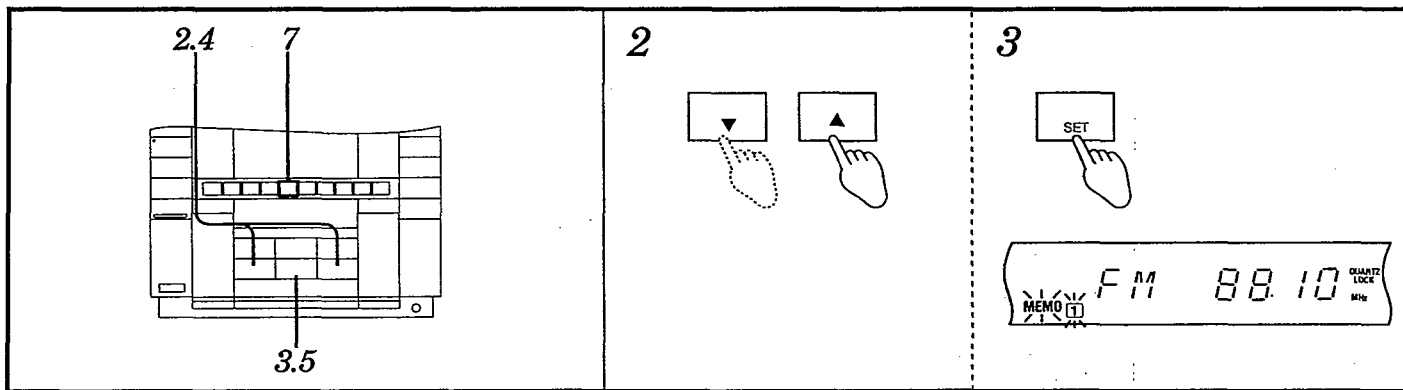

## Memory presetting-MANUAL

This example shows how to memorize FM 88.10 MHz into channel 4.

- 1 **Set your stereo to memorize stations.**
- 2 **Tune in the desired station with ▼ and ▲.**  
The frequency will change every time either ▼ or ▲ is pressed (manual tuning). Also, if you hold down one of the cursor buttons for about 1 second and release it when the numbers start scrolling, the tuner will stop at the station that is easiest to pick up (auto tuning).
- 3 **Press SET momentarily.**
- 4 **Select the channel where to memorize the station, with ▼ and ▲.**

- 5 **Press SET.**
- 6 **Preset other stations in memory.**  
Follow above steps 2–5.
- 7 **Press MEMORY.**  
(Manual memorization is now over.)

### To check the memorized stations

- ① Press MODE to select "PRESET".
- ② Press ▼ and ▲.

### Memory retention

Stations can be retained in memory for about 1 month while your stereo is unplugged or otherwise while power is put on standby.

## LISTENING TO COMPACT DISCS

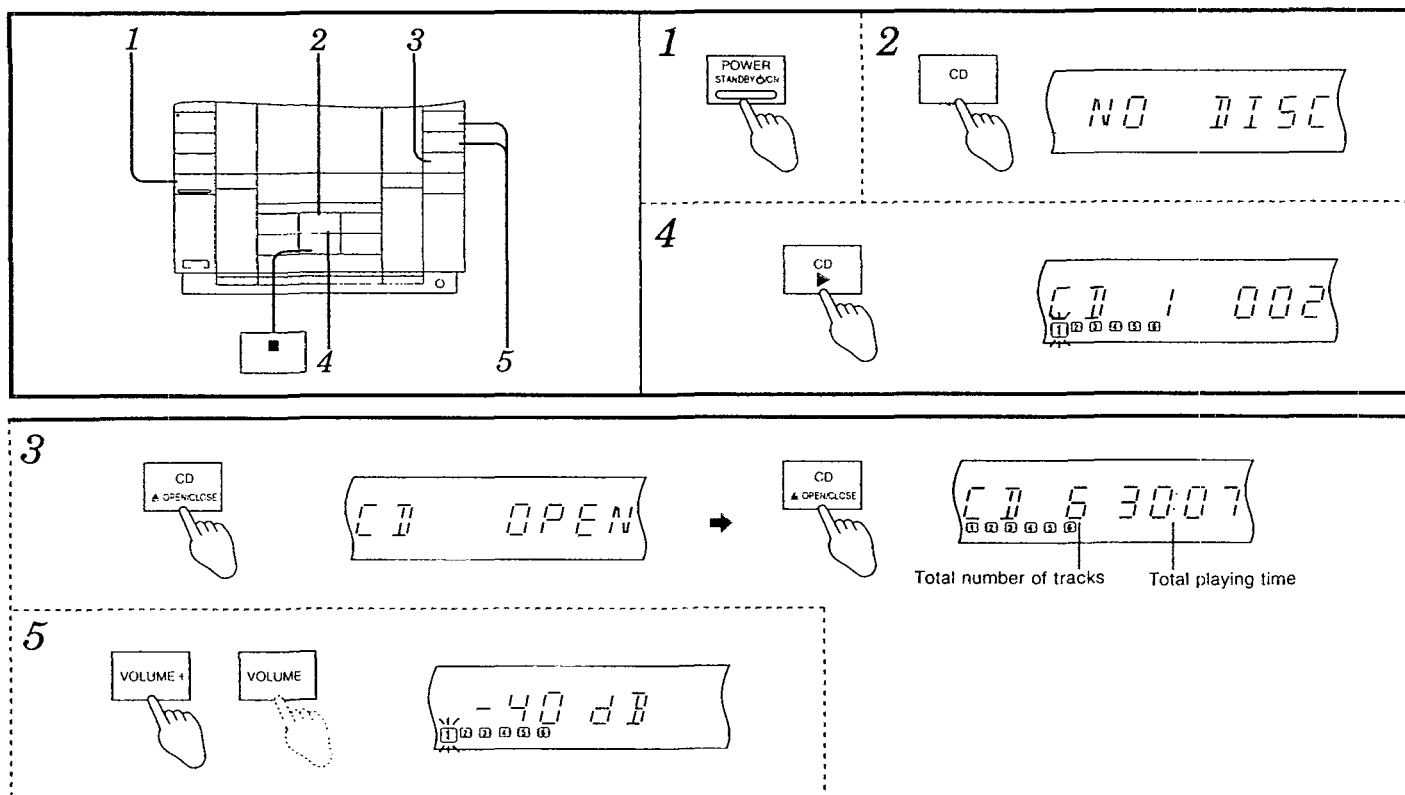

## Sequential play

Sequential play means you begin listening to the first track and continue in order to the last track.

- 1 **Press POWER.**
- 2 **Press CD.**  
"NO DISC" is displayed when no disc has been loaded into the CD player.
- 3 **Press CD ▲ OPEN/CLOSE and load a disc.**  
To put a disc on, press on the center of the disc with your finger until the disc snaps into place.

Make sure the label is facing upwards.

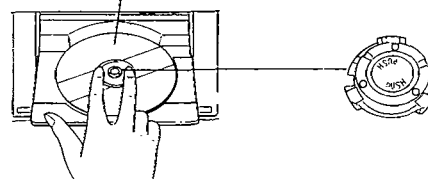

To take a disc off, while pressing PUSH, lift the disc outward.

The cover closes when CD ▲ OPEN/CLOSE is pressed a second time.

### Note

The total playing time displayed when a disc is loaded includes intervals between tracks. This is why sometimes the displayed time is longer than that listed on the CD.

**4 Press CD ► to start sequential play.**

The disc begins playing from the first track and stops automatically when the last track on the disc finishes playing.

**5 Adjust volume with VOLUME (+/-).**

To stop the disc

Press ■.

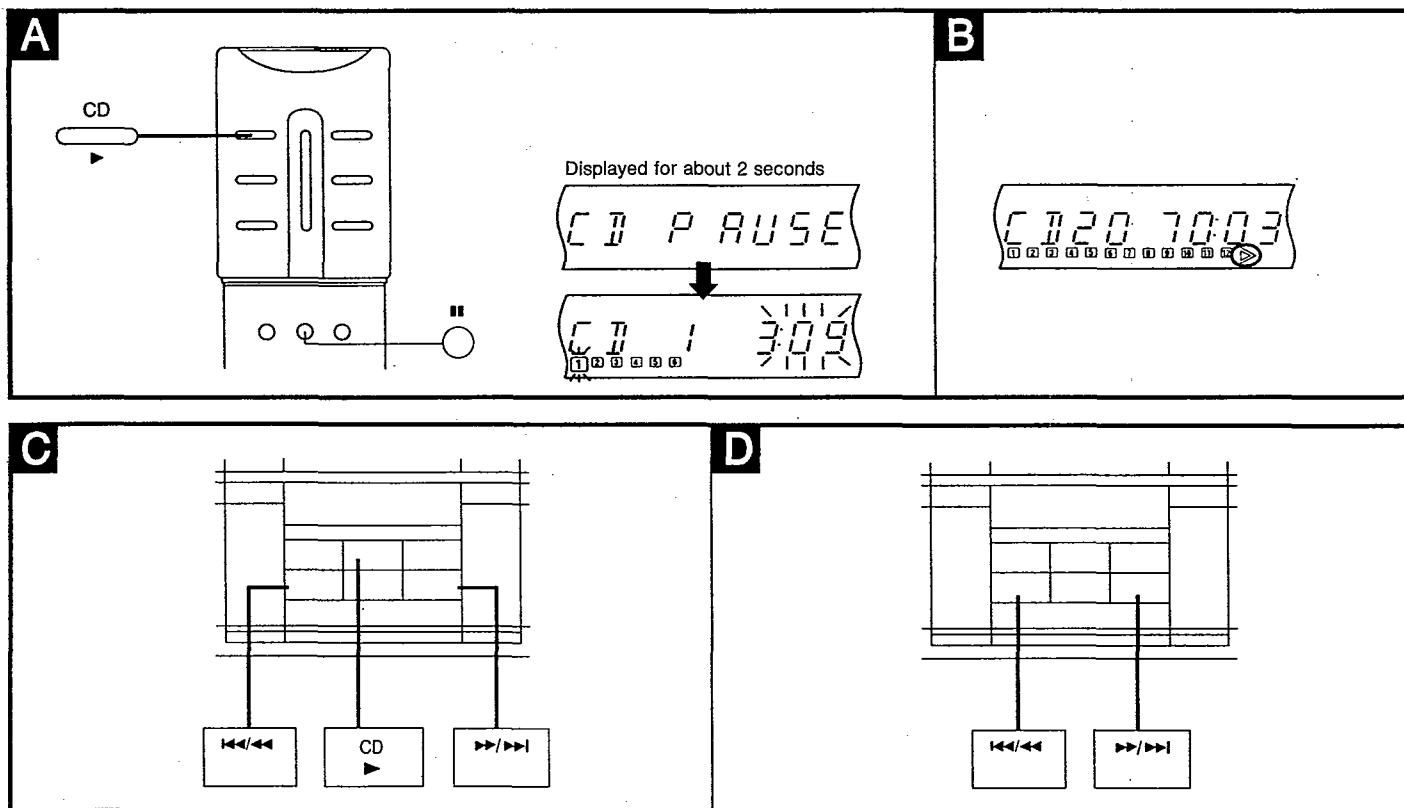

To temporarily stop the disc **by remote control only** **A**

Press ■.

**To play a track again**

Press CD ► on the remote control. The same is possible from CD ► on the stereo.

**For your reference**

- When there are 13 or more tracks on the disc, ► will appear.

**B**

- The CD will stop automatically if, while playing, the source is switched to the radio or tape player.
- The front panel will close automatically and playing will start when a disc is loaded and CD ► is pressed.
- Playing starts by just pressing CD ►, when a disc is loaded and the source is set to "CD".

**Listening from a special track onward** **C****1 Prepare a CD for playing****2 Press either |◀◀/◀◀ or ▶▶/▶▶| until you reach the desired track.****Note**

The track number will not change when either of the buttons is held down.

**3 Press CD ►.****Skip/Search** **D**

What to do	Buttons
<b>Skip forward/backward (skip function): tap during play.</b>	▶▶/▶▶ : Forward direction
<b>Rapid forward/backward (search function): keep depressed during play.</b>	◀◀/◀◀: Backward direction

**For your reference**

While listening to the programmed tracks, the CD player works as follows.

**Skip function**

Skips ahead or backward between tracks in the programmed order.

**Search function**

Fast forwards or rewinds the playing track only.

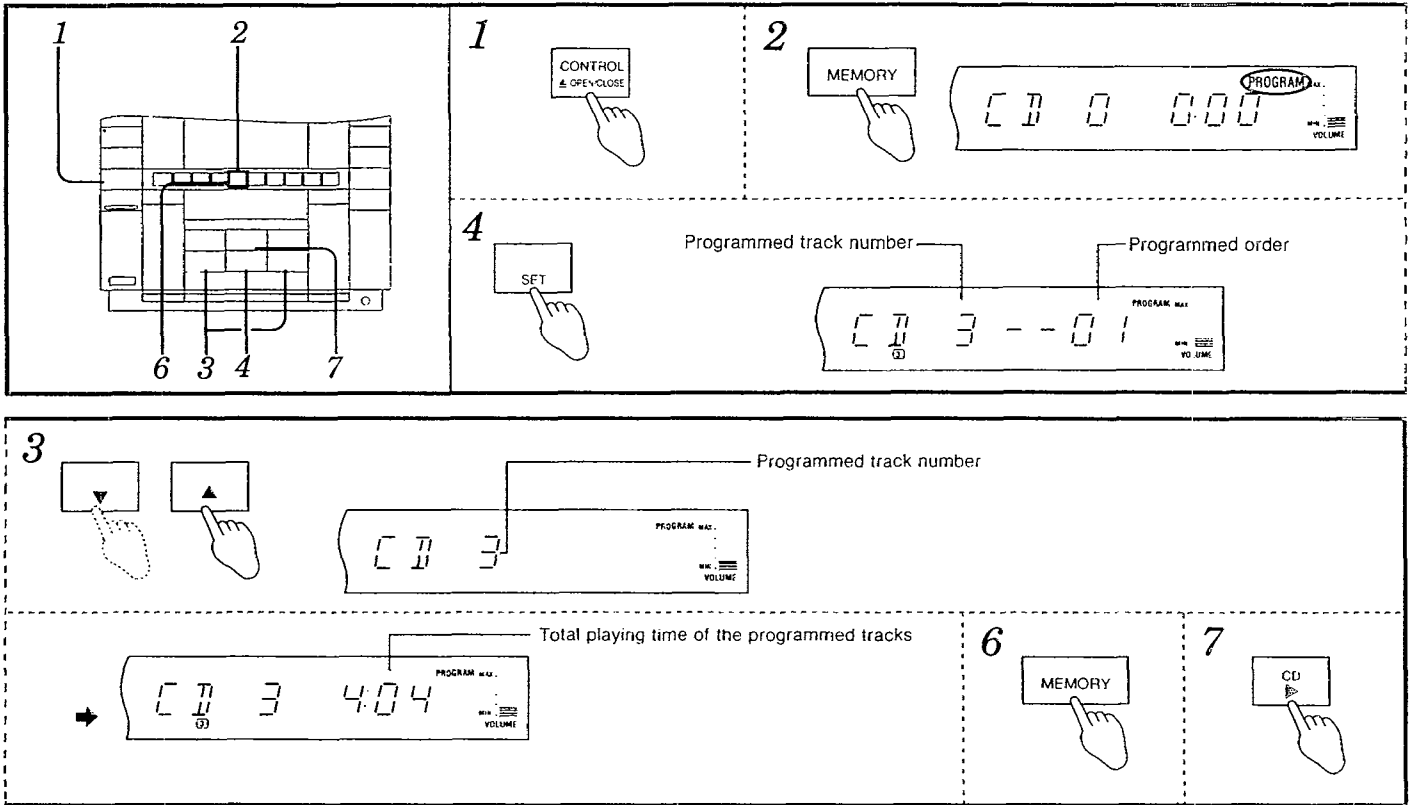

## Program play

### Preparations

Set the source to "CD" and load a disc.

- Press **CONTROL ▲ OPEN/CLOSE**.  
The front panel will open, exposing the control panel.
- Press **MEMORY**.
- Select the track number you want to program with **▼** and **▲**.
- Press **SET**. (This programs the track number.)
- Select the rest of the tracks you want to play in the desired sequence.  
Repeat steps 3–4 above.  
Playing time is added to the display with every track programmed.

**6** Press **MEMORY**.

**7** Press **CD ▶** to start program play.

### To check programmed tracks

Press **◀◀/▶▶** and **▶▶/▶▶**. The CD must be stopped when these buttons are pressed. The programmed track number and programmed order will be displayed each time one of the buttons is pressed.

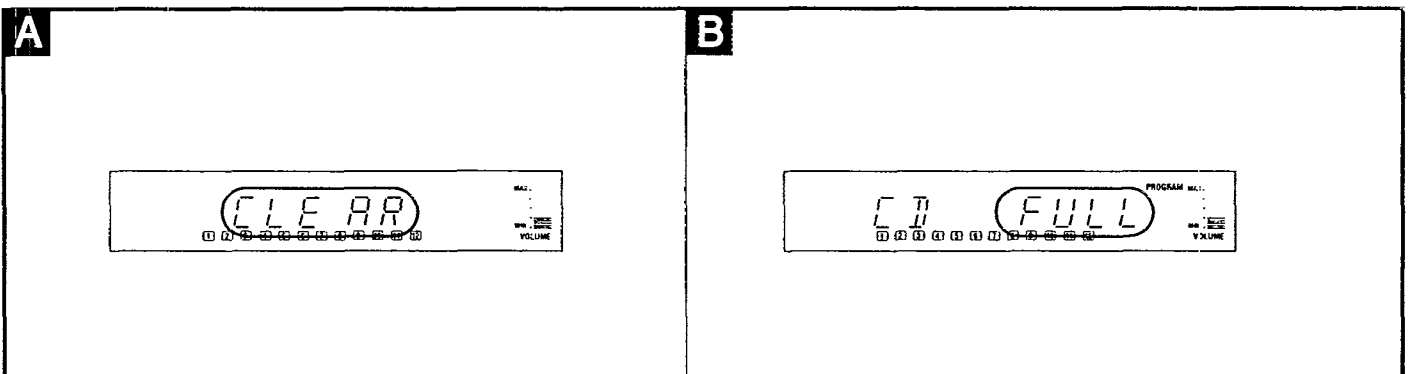
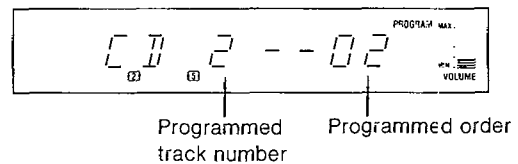

### To cancel the program play mode **A**

Stop the CD, if playing, and press **MEMORY**. "CLEAR" will be displayed for about 1 second, followed by the total playing time. This will erase all programmed information.

### To change programming

Disengage the program play mode and reprogram from the beginning.

### When the number of programmed tracks exceeds 24 **B**

"FULL" is displayed.  
Further programming is not possible.

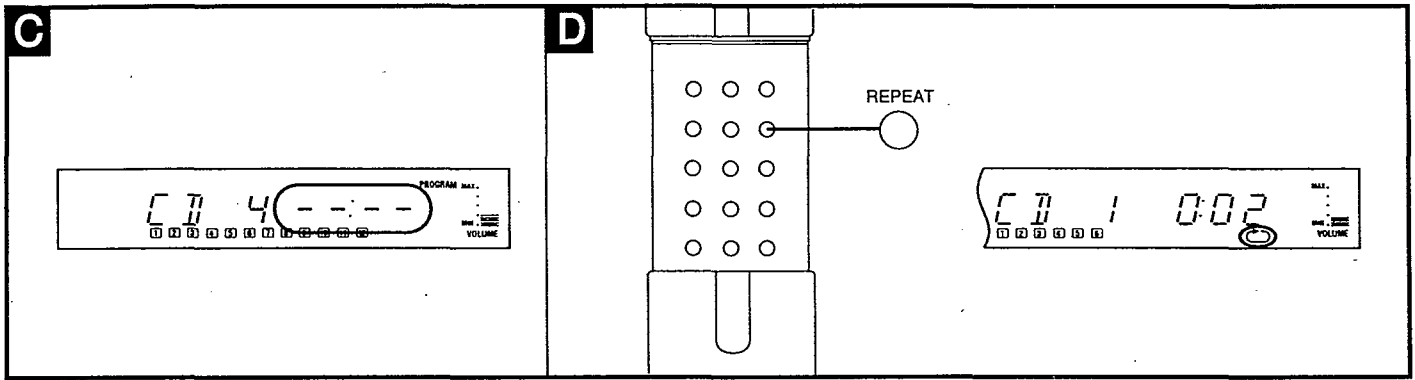

**When the total playing time of the programmed tracks exceeds 99:59** **C**  
 " - - : - - " is displayed.  
 Programming and playing is still possible when this indication is displayed.

**When the front panel is opened or closed.**  
 All programmed information is erased.

**For your reference**  
 Except in the following cases, programmed information is retained in memory when power to the stereo is put on standby.

- When the front panel is opened or closed
- When either MEMORY or **■** is pressed while the CD is stopped

**Repeat playback by remote control** **D**

**To repeat all tracks**

**Press REPEAT before playing starts or while a CD is playing.**  
 Press it again to cancel the request.

**For your reference**  
 While listening to the programmed tracks, only programmed tracks are repeated when the repeat function is set.

**To repeat only a single track**

- 1 Program only one track
- 2 Press REPEAT on the remote control.

**■ LISTENING TO TAPES**

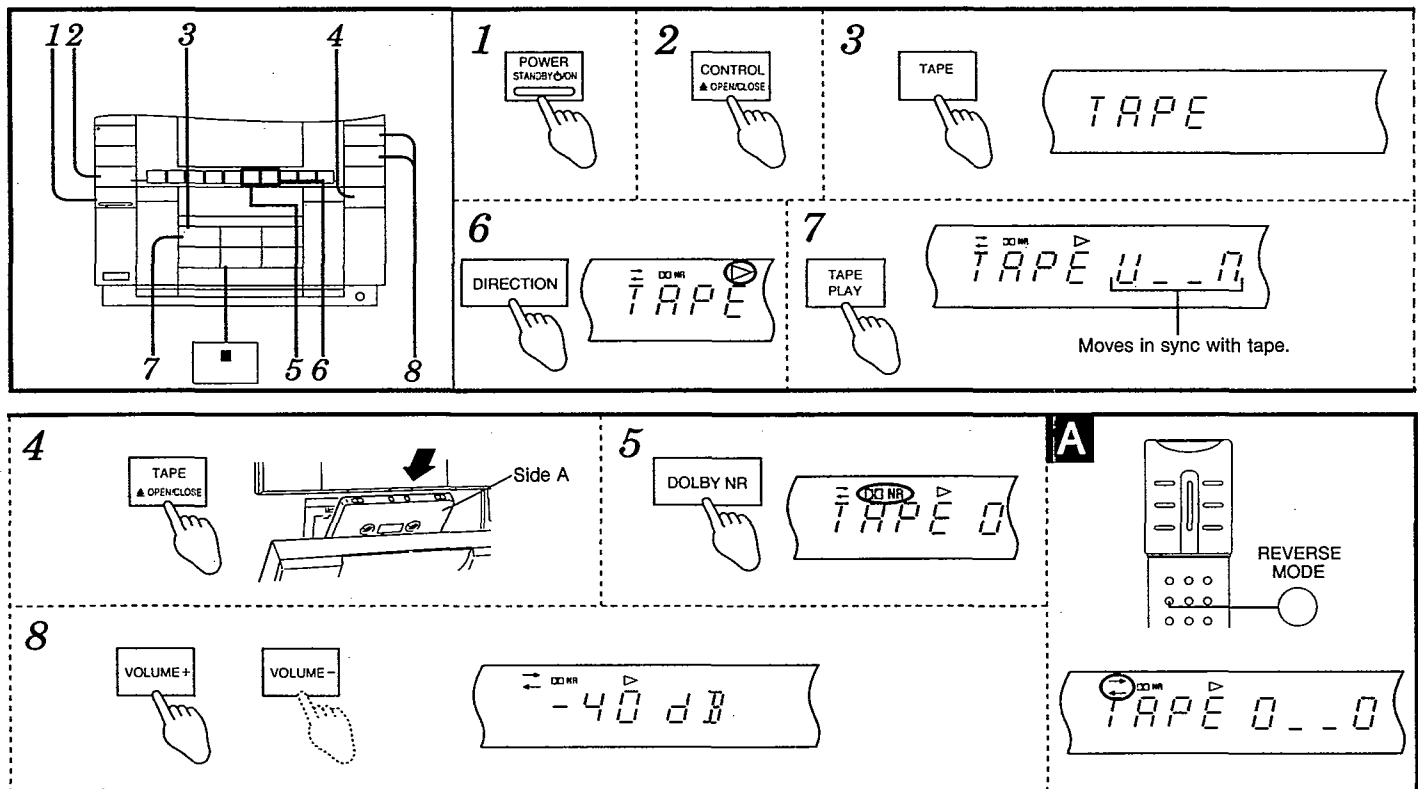

You can play back normal, chrome and metal tapes.

- 1 Press **POWER**.
- 2 Press **CONTROL OPEN/CLOSE**.  
 The front panel will open, exposing the control panel.
- 3 Press **TAPE**.
- 4 Press **TAPE OPEN/CLOSE**, and then insert the cassette tape with tape side facing downward.  
 The cassette holder closes when the button is pressed a second time.



- 5 To listen to a tape recorded in Dolby B NR  
**Press DOLBY NR and check " NR" is displayed.**  
 When playing back a tape which was not recorded on Dolby NR system, press DOLBY NR so that the indications go off.
- 6 **Press DIRECTION to select the tape direction.**  
 ▷: To listen from side A  
 ◁: To listen from side B
- 7 **Press TAPE PLAY** (playback will begin).
- 8 **Adjust volume with VOLUME (+/-).**

**To stop tape playback**

Press ■.

**To select the reverse mode *by remote control only***

Press REVERSE MODE.

- ↔ : Single side playback
- ↔↔ : Playback from both sides (one time each)
- ↔↔↔ : Playback from both sides (up to 8 times per side)

**For your reference**

When the source is set to "TAPE" and a tape is loaded, playing starts by just pressing TAPE PLAY.

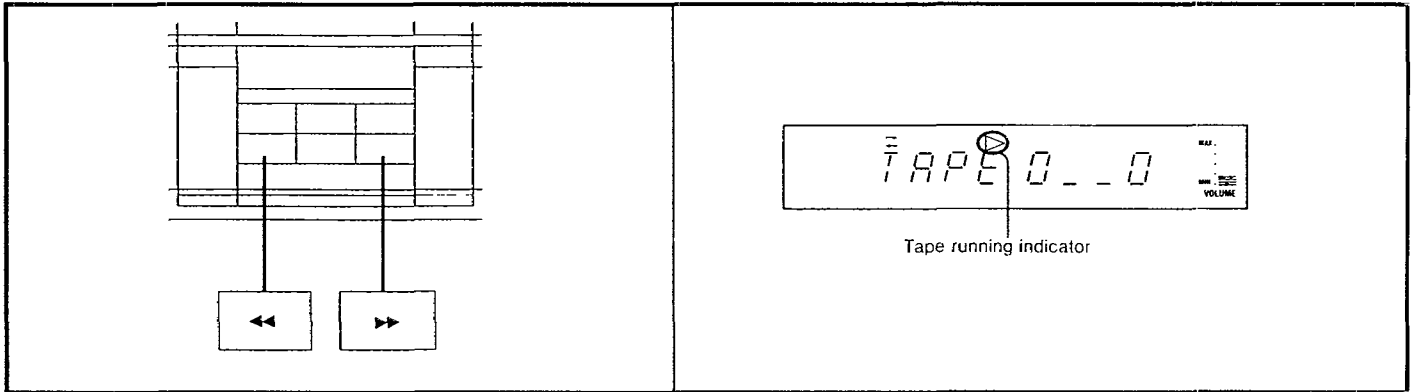

**To fast forward or rewind the tape**

**While the tape is stopped**

Press ◀◀ or ▶▶.

Tape running indicator	Rewind	Fast forward
▷	◀◀	▶▶
◁	▶▶	◀◀

Tape running indicator	Playback from the beginning of the program	Playback from the beginning of the next program
▷	◀◀	▶▶
◁	▶▶	◀◀

**To find the beginning of a track (TPS: tape program sensor)**

**While the tape is playing**

Press ◀◀ or ▶▶.

**High speed**

This tape deck automatically fast forwards and rewinds at twice the normal speed. But, to protect the tape from popping, the tape deck reverts back to normal speed when near the end of the tape.

**Note**

The tape may not move at high speed when fast forwarded or re-wound from the middle.

**LISTENING TO RADIO BROADCASTS**

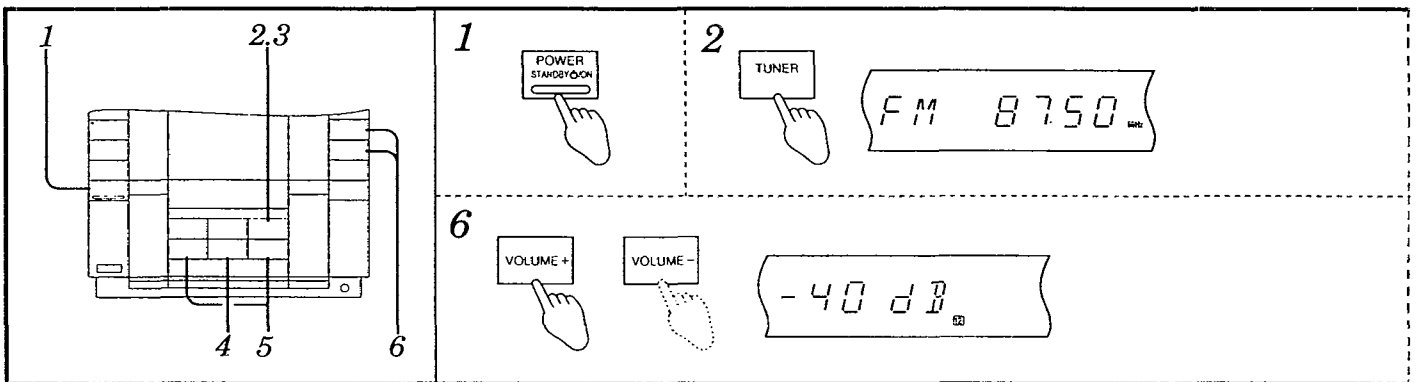

**Preset tuning**

**Preparations**

Before tuning, memorize a radio station

1 Press POWER.

2 Press TUNER.

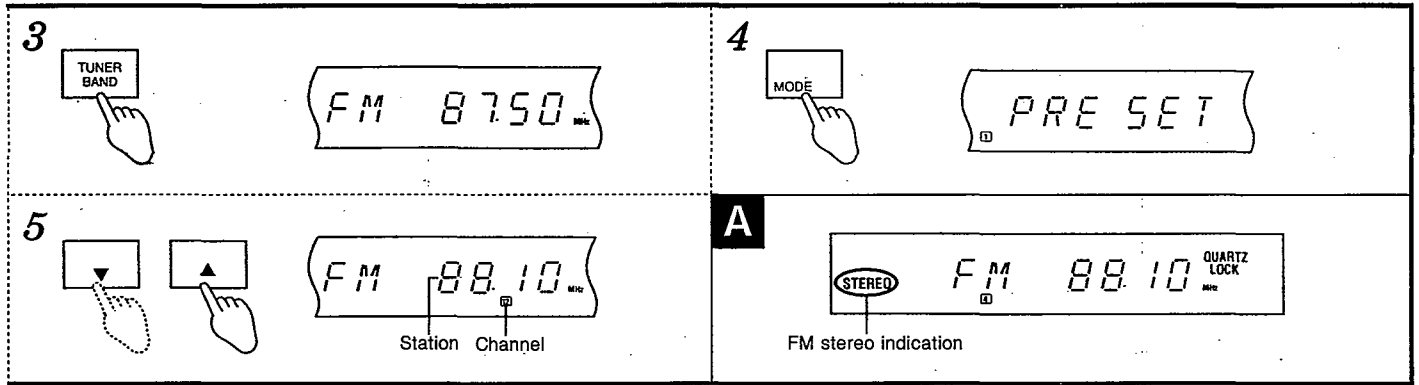

**3 Press TUNER BAND to select the desired band.**  
 Each time the button is pressed, the indication will change as follows.  
 FM → MW → LW

**Note**  
 The MW frequency step is set to 9 kHz at the time of shipment from the factory. To change to 10 kHz per step, hold down TUNER BAND for 2 seconds while the "MW" is displayed.

**4 Press MODE to select "PRESET".**  
 Each time the button is pressed, the indication will change as follows.  
 PRESET → MANUAL

**5 Select the desired channel with ▼ and ▲.**

**6 Adjust volume with VOLUME (+/-).**

**When an FM stereo broadcast is picked up **A****  
 The unit will automatically switch to FM stereo reception and the FM stereo indication will light up.

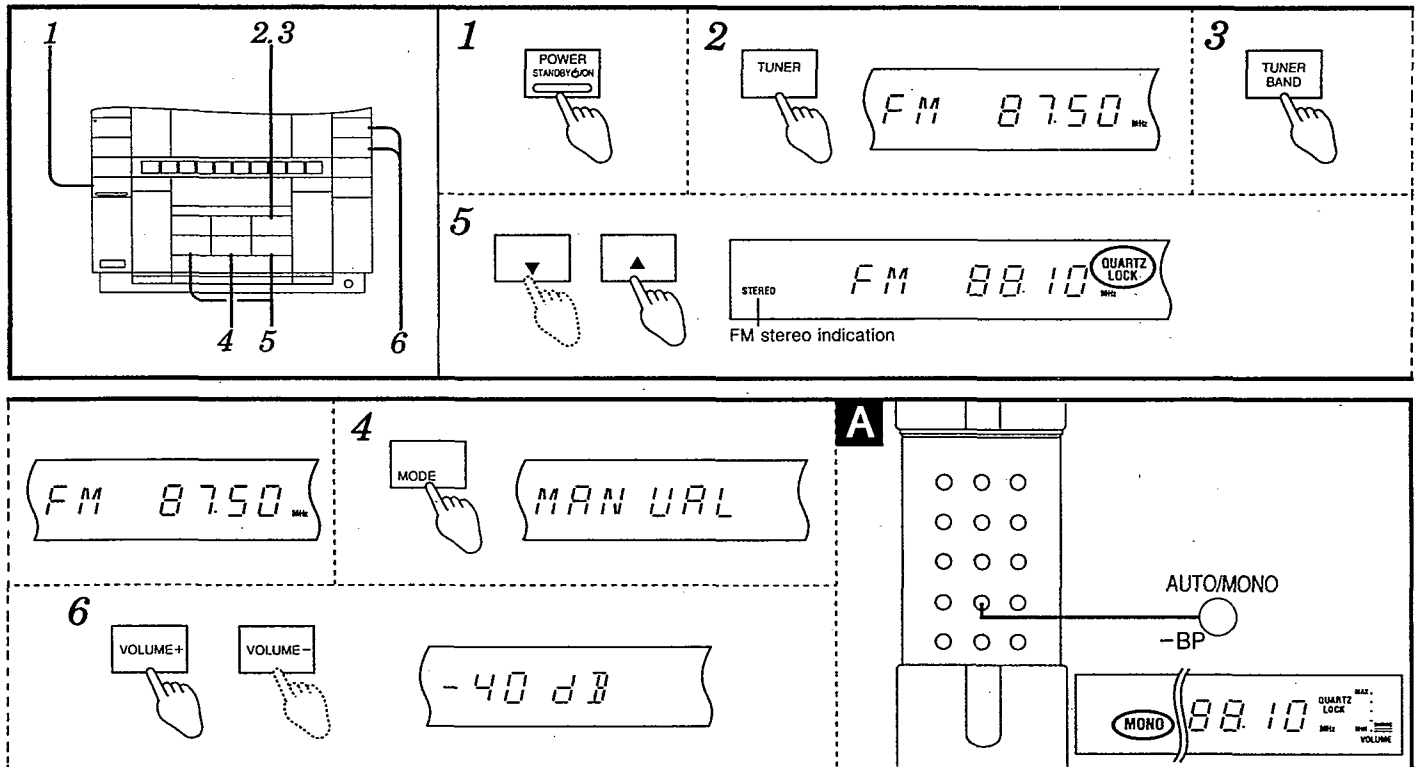

**Sequential tuning**

**1 Press POWER.**

**2 Press TUNER.**

**3 Press TUNER BAND to select the desired band.**  
 Each time the button is pressed, the indication will change as follows.  
 FM → MW → LW

**Note**  
 The MW frequency step is set to 9 kHz at the time of shipment from the factory. To change to 10 kHz per step, hold down TUNER BAND for 2 seconds while the "MW" is displayed.

**4 Press MODE to select "MANUAL".**

Each time the button is pressed, the indication will change as follows.

PRESET → MANUAL

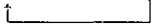
**5 Tune in the desired station with ▼ and ▲.**

If either button is held down until the frequency begins to scroll, broadcast stations are tuned in automatically when found.

"QUARTZ LOCK" light up when a station is picked up clearly.

**Note**

Tuning may stop automatically if any jamming is encountered

**6 Adjust volume with VOLUME (+/-).****If too much noise is produced in the FM mode****by remote control only:** 

Press AUTO/MONO-BP and check "MONO" indication lights up. The sound will then be heard in monaural. If the broadcast signal is weak, or if there is a large amount of interference, you will get a clearer sound.

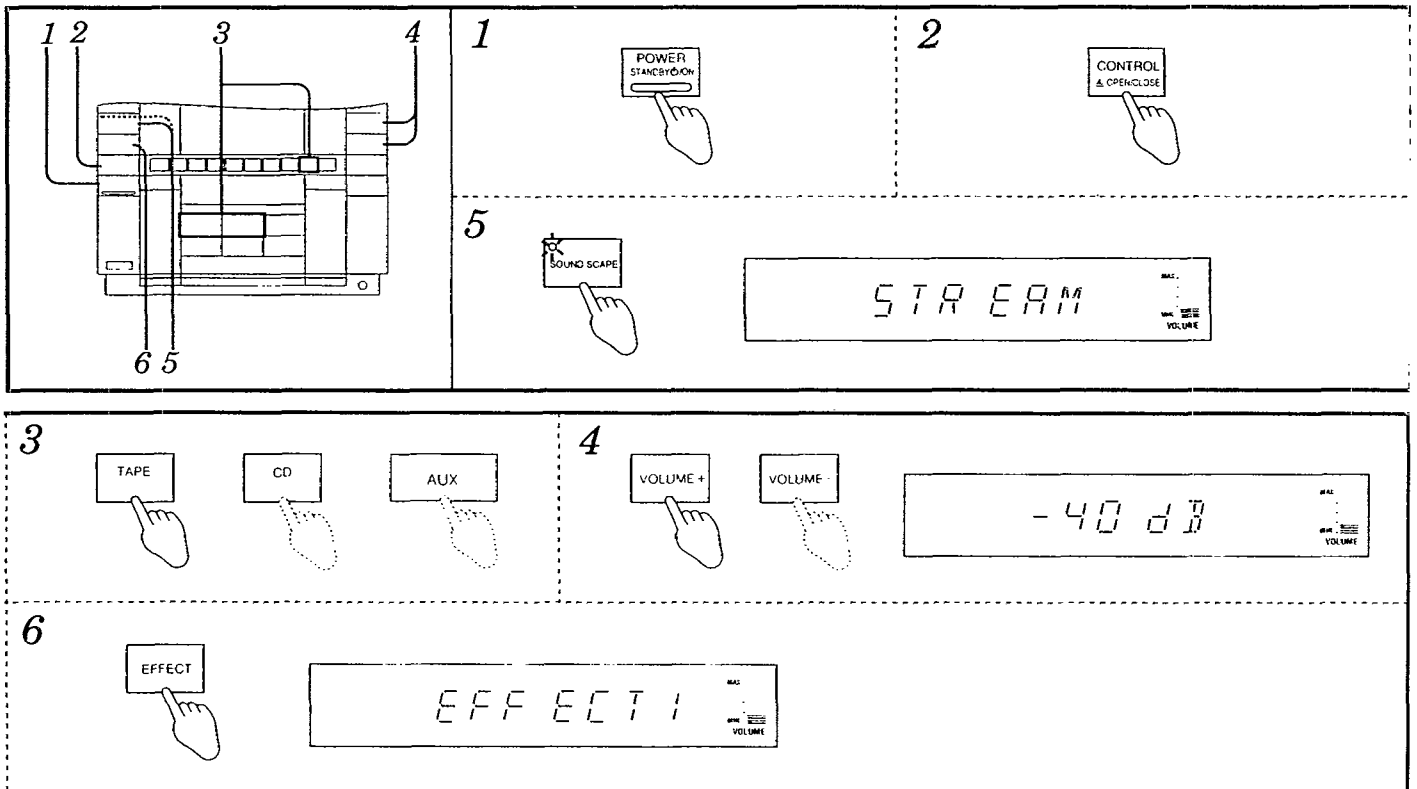
**LISTENING WITH SOUNSCAPE**

For your listening pleasure, this stereo recreates for playback three natural environmental sounds: the murmur of a rolling brook, the sound of waves lapping on the beach, and the twittering of birds and crickets.

**1 Press POWER.****2 Press CONTROL OPEN/CLOSE.**

The front panel will open, exposing the control panel.

**3 Set the input source to "TAPE", "CD" or "AUX".****Note**

This function is OFF when the input source is set to "TUNER".

**4 Press VOLUME (+/-) to set the normal level of listening pleasure.****5 Press SOUNSCAPE to select the desired natural environmental sound.**

(The button's indicator will light up.)

**STREAM:** murmur of a rolling brook

**BEACH:** sound of waves lapping on the beach

**FOREST:** twittering of birds and crickets

Each time the button is pressed, the indication will change as follows.

STREAM → BEACH → FOREST

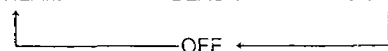
**6 Press EFFECT to select the magnitude of the sound.**

Magnitude is broken down into 4 levels: EFFECT1 (minimum)–EFFECT4 (maximum).

Each time the button is pressed, the indication will change as follows.

EFFECT1 → EFFECT2 → EFFECT3

**For your reference**

Mixing with a selected environmental sound is possible when the source is played back following above step 6. The mixed sound can be recorded as well.

You can also record the environmental sound alone without mixing.

When the time of day is set (Refer to "Setting the time", page 11.)

The same or a different environmental sound can be set for playback during three set periods of the day: "6:00-11:59", "12:00-17:59", "18:00-5:59". For example, the rolling brook can be set for the morning and the sound of owls and crickets for the evening.

**Note**

Unless the timer is set, the selected sound is played automatically from 12:00 to 17:59.

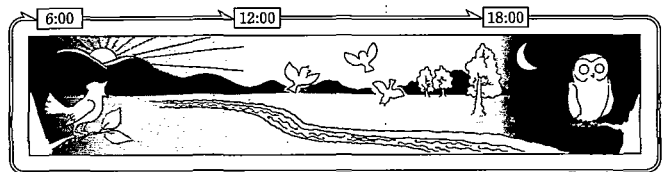

## CHANGING SOUND QUALITY AND FIELD

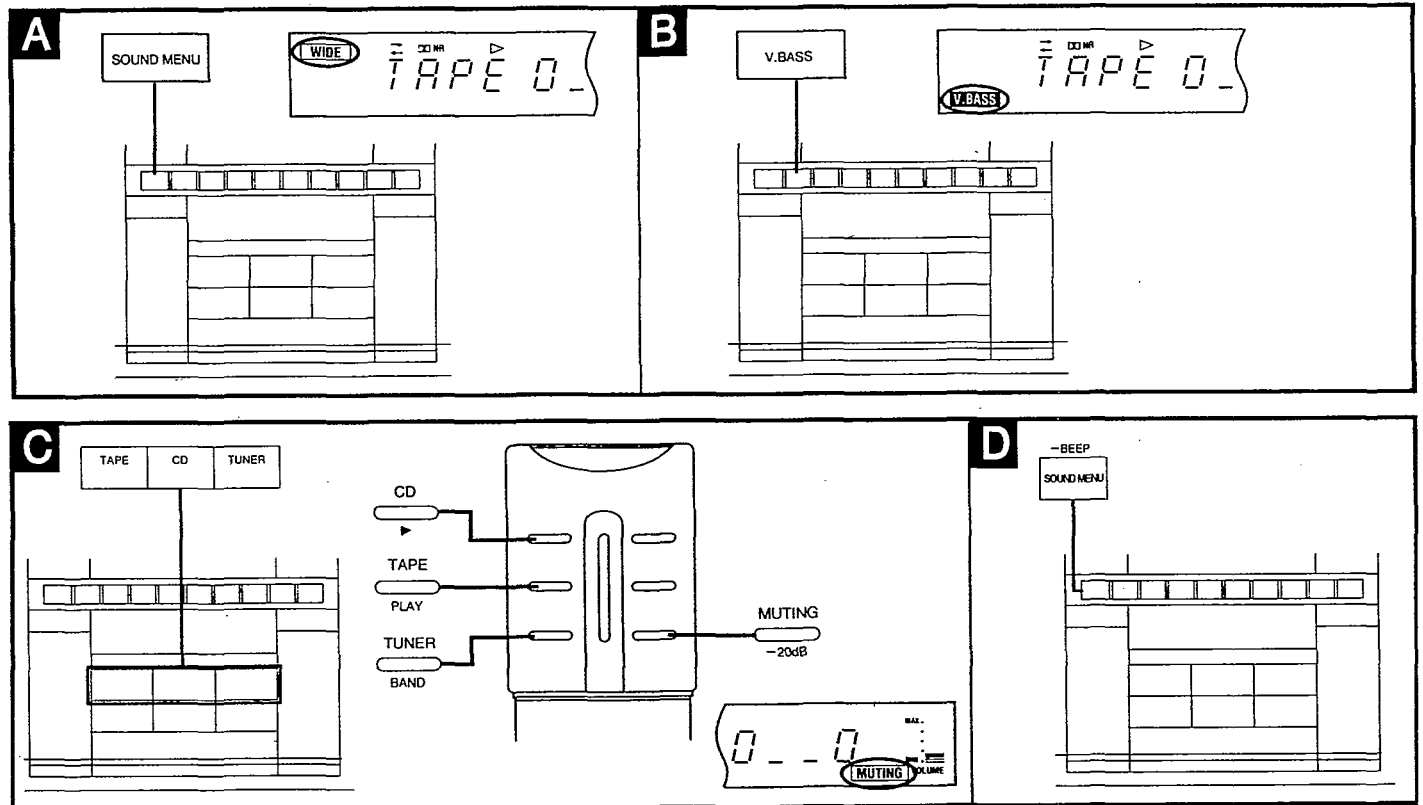

### Selecting sound quality and field **A**

Press **SOUND MENU** to select the desired mode.

Each time the button is pressed, the indication will change as follows.

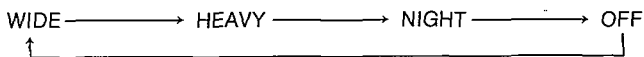

**WIDE:** Makes sounds spread outward.

**HEAVY:** Makes sounds stronger, effective with rock music to add punch.

**NIGHT:** Modulates sounds even when listening at low volume.

### Adding bass **B**

Press **V. BASS**.

Press the button again to cancel.

### Easy play **C**

When you load a CD or cassette in advance, you can start play directly from standby by pressing the appropriate selector button (TAPE, CD or TUNER).

Play will start with volume increasing gradually up to the volume level you set last.

### To mute the volume **C**

*by remote control only*

Press **MUTING**.

This feature is convenient when you have a telephone call, etc. To cancel the muted state, press **MUTING** once again.

### Beep tone **D**

A beep is produced when **SELECTOR/OPERATION** or a remote control button is pressed.

To silence the beep tone, hold **SOUND MENU -BEEP** down until a beep is heard. Do this again to revert the function back as before.

# RECORDING FROM COMPACT DISCS

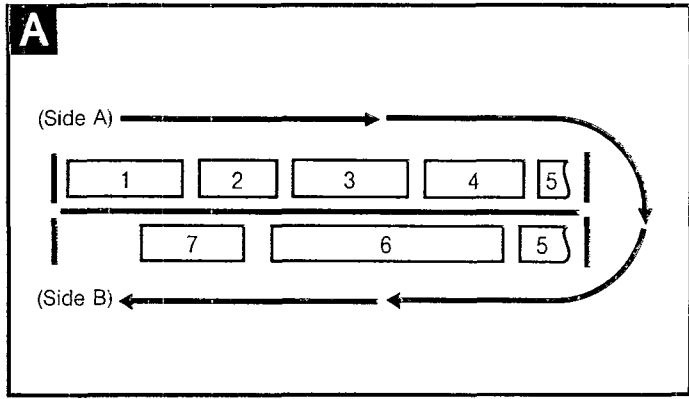

You can record on normal, chrome, and metal tapes.

## Ways to record

There are 2 ways to record from compact discs.

### Normal recording **A**

In normal recording, no blank space is left at the end of side A. But, this means a track will be cut off in the middle when the end of the side is reached. This method can also be used to record onto a tape from a desired point halfway through one side.

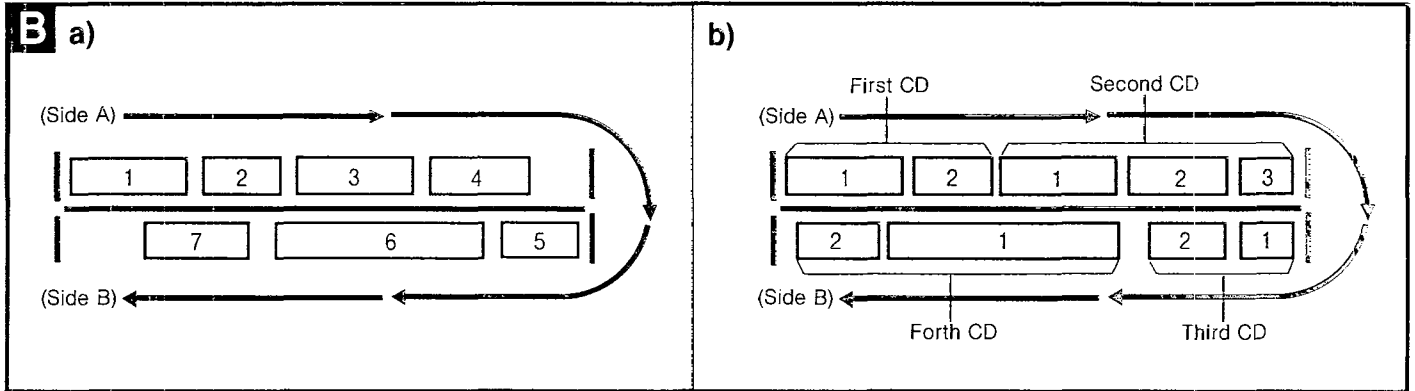

## Edit-recording **B**

**a) To edit tracks in sequence from a single CD (Normal edit)**  
(See page 23.)

The tape deck automatically reads the length of the loaded tape, and then calculates which tracks go on which side of the tape so that no track is cut in the middle at the end of either side.

**b) To edit several CD's on a single tape (LINK)**  
(See page 24.)

After edit-recording a loaded disc, you can subsequently edit-record another disc on the remaining blank portion of the tape.

### Note

Sound quality and acoustical effect cannot be recorded.

In the following cases, "ERROR" is displayed and edit-recording is not possible from CD's.

- When total program time is 100 minutes or more
- When the CD contains 37 or more tracks
- When a tape with a broken protect tab has been loaded
- When any one track is longer than one full side of the tape

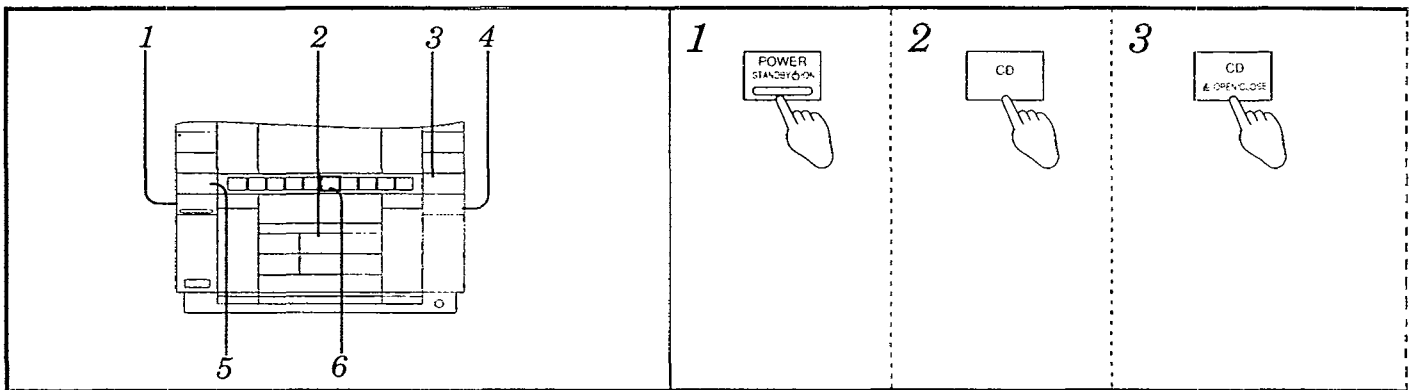

## Normal recording

### Preparation

Wind the leader of the tape forward till ready for recording.

Ex.: To record onto side A

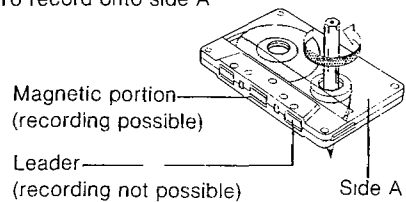

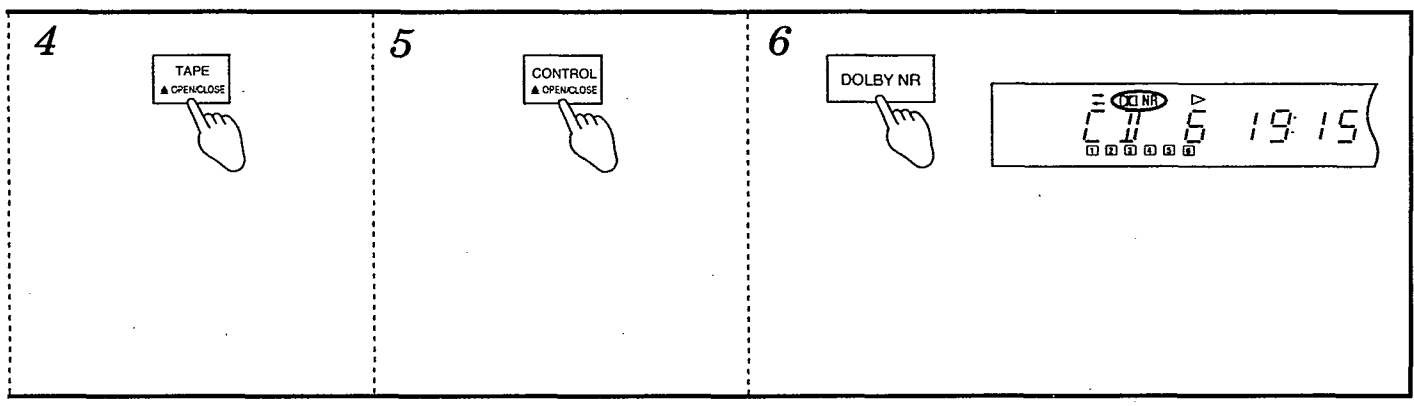

- 1 Press POWER.**
- 2 Press CD.**
- 3 Press CD OPEN/CLOSE, and load the CD.**  
When the button is pressed a second time, the front panel closes.
- 4 Press TAPE OPEN/CLOSE, and load the tape.**  
When the button is pressed a second time, the holder closes.  
**For your reference**  
If TAPE OPEN/CLOSE is pressed while the front panel is open, the front panel automatically closes.
- 5 Press CONTROL OPEN/CLOSE.**  
The front panel will open, exposing the control panel.
- 6 To record in Dolby B NR, Press DOLBY NR and check " NR" is displayed.**

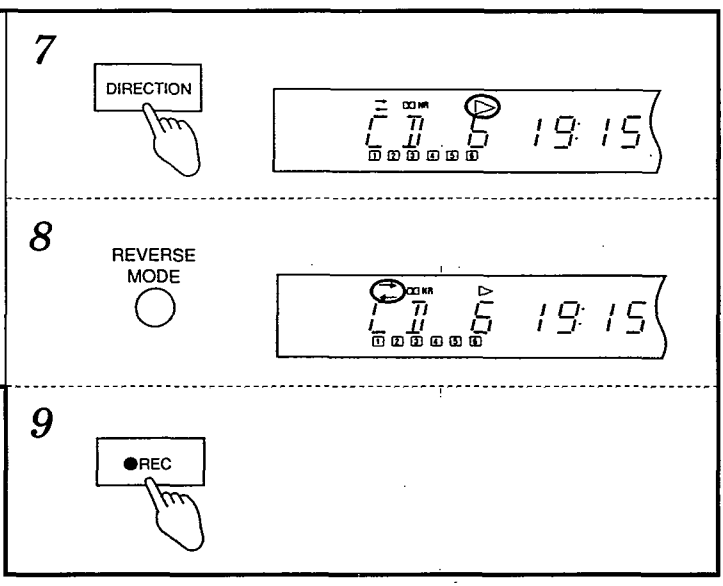
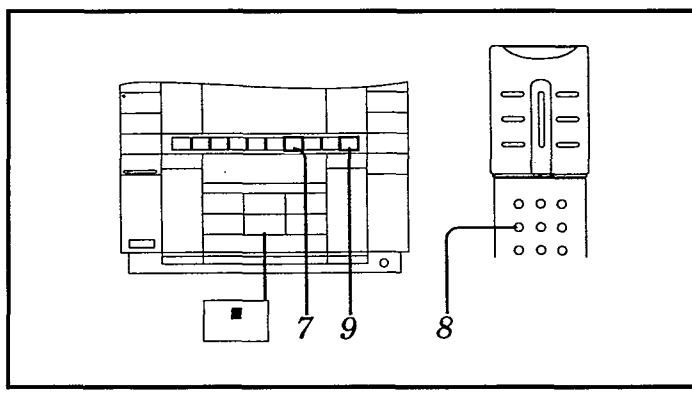

- 7 Press DIRECTION to select tape direction.**  
▷: Recording from side A  
◁: Recording onto side B
- 8 When ▷ was selected in step 7 Press REVERSE MODE on the remote control, to select the reverse mode.**

Each time the button is pressed, the indicator will change as follows.

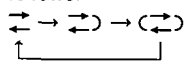

- ↔: The tape automatically stops after recording on one side.
- ↔ (↻): The tape automatically stops after recording on both sides.

When recording, if (↻) is selected, the reverse mode automatically changes to ↔ to prevent you from recording over the first side.

- 9 Press ● REC.**  
(Recording starts the moment the CD program does.)

**To stop recording after a 4 second silent interval**

- Press ■.
- To stop recording without a silent interval**
- Press ● REC.

**To record a programmed track**

Program the desired track by following steps 1 through 6 on page 15, followed by steps 4, 6-9 on this page.

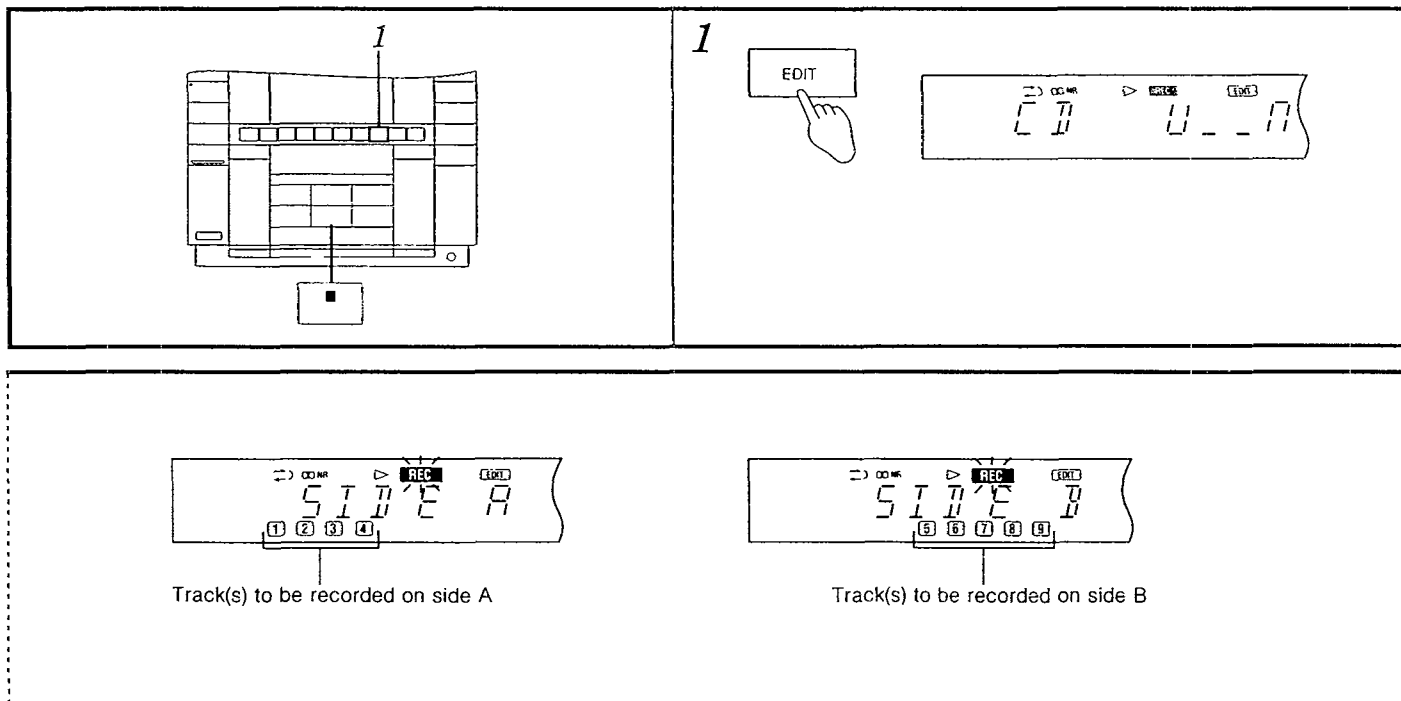

## Edit-recording (normal editing)

### Preparation

Load the tape and CD to be used in recording.  
(Refer to steps 1 through 8 on pages 21 and 22.)

- Step 7 is unnecessary because edit-recording starts automatically from side A.
- In step 8, select  $\leftrightarrow$  for the reverse mode.

### For your reference

In CD edit-recording, it is not necessary to wind the leader of the tape forward because the tape deck automatically fast-forwards the tape.

### 1 Press EDIT (recording starts).

The tape deck takes a moment to read the length of the loaded tape and calculate where to divide side A and B. Once complete, the track(s) to be recorded on side A and B are each displayed for about three seconds before recording actually starts. Both the tape and CD stop automatically when recording is over.

### For your reference

In normal edit-recording, the tape deck takes a short time before recording actually starts, to perform the following operations.

1. The tape deck fast-forwards and reverses the tape to calculate its length.
2. After reversing the tape, the tape deck automatically calculates where to divide the tracks for side A and B.
3. The tape deck starts recording.
  - After the last track has been recorded onto side A, the tape deck continues recording in silence until the end of the tape is reached, so as to measure the length of the tape. This happens only when recording onto both sides.
  - The length calculated by the tape deck and the actual length of the tape may differ. While recording onto side A, the actual length is measured and corrected.

### To stop recording in progress or to turn OFF the CD edit-recording mode after recording

Press  $\blacksquare$ .

"CLEAR" will be displayed for about two seconds before the edit-recording mode is turned OFF.

### To record a programmed track

Program the desired track by following steps 1 through 6 on page 15, followed by the steps on this page.

### When "REC" and "LINK" flash on the display after recording

This indicates recording space remains on the tape. To continue recording, perform the LINK operation on page 24.

### When all tracks or a group of selected tracks cannot fit on the tape

"OVER" is displayed for about two seconds. But, if the first track fits, recording begins and will continue for all tracks that fit onto the tape.

### Note

Use a 99 minute or shorter tape for recording. The tape deck cannot calculate length of longer tapes accurately, which may result in extensive blank space on side A.

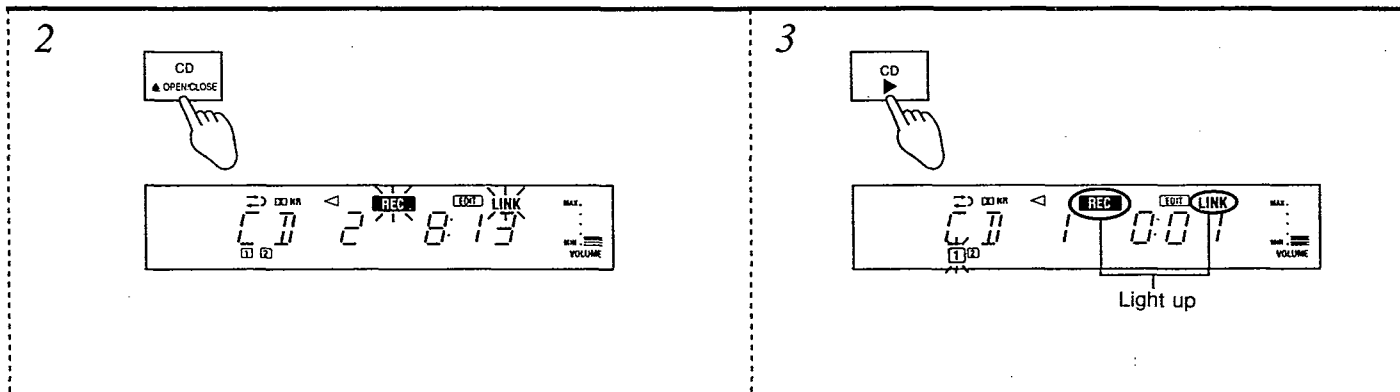
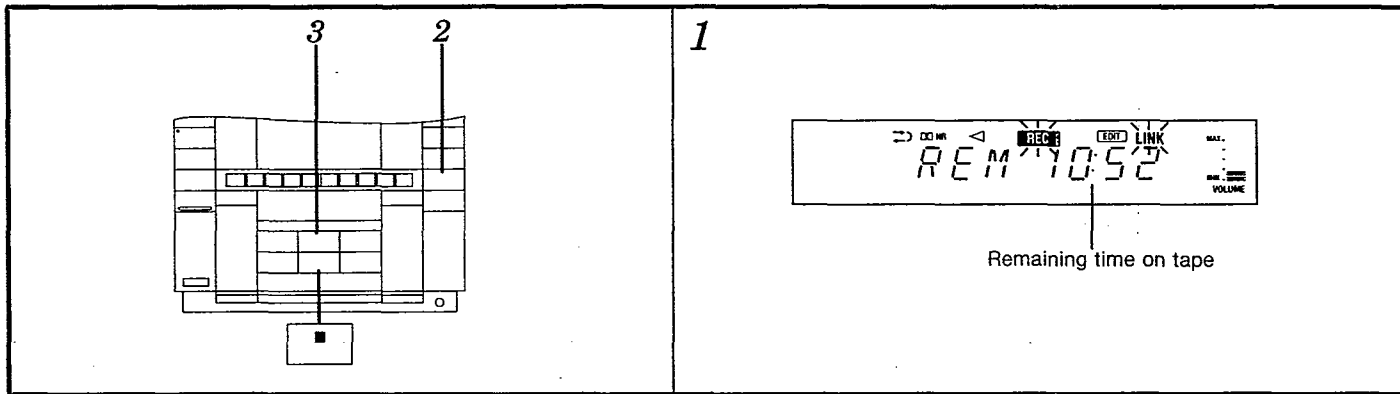

**Edit-recording (LINK)**

**1 Edit-record from the first CD (normal editing)**

Check "REC" and "LINK" are flashing on the display.

**2 Press CD ▲ OPEN/CLOSE to replace the disc with another disc.**

Press CD ▲ OPEN/CLOSE again to close the front panel.

**3 Press CD ► (track linking begins).**

**4 Repeat steps 2–3 to record more discs.**

**To stop recording in progress or to turn OFF the CD edit-recording mode after recording**

Press ■.

"CLEAR" will be displayed for about two seconds before the edit-recording mode is turned OFF.

**To record a programmed track**

1. Perform above steps 1 and 2.
2. Program the desired tracks by following steps 1 through 6 on page 15.
3. Perform above step 3.

**When all tracks or a group of selected tracks cannot fit on the tape**

"OVER" is displayed for about two seconds. In this case, linking is not possible. You have the choice to change the CD with one that will fit within the remaining time, or to program a track that will fit within the remaining time, or to quit recording.

**RECORDING FROM RADIO BROADCASTS**

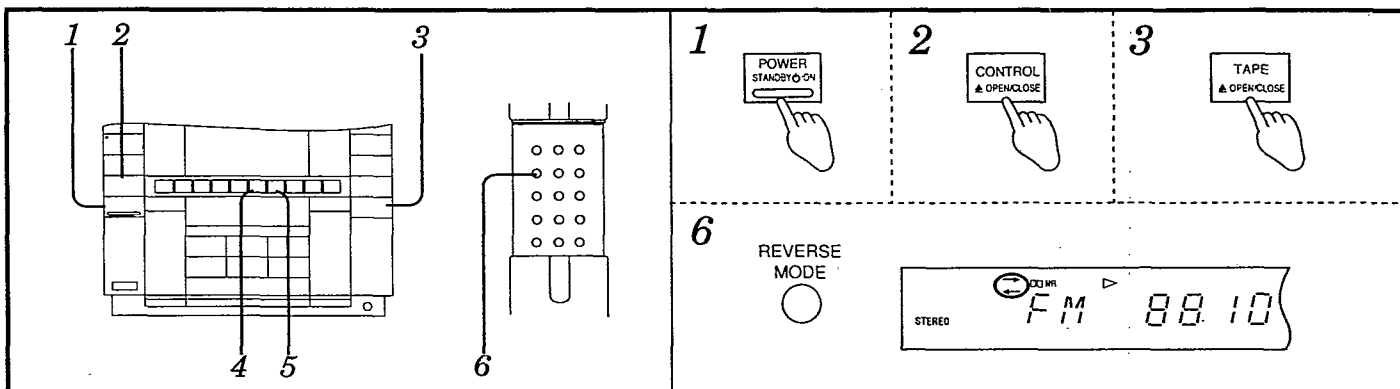



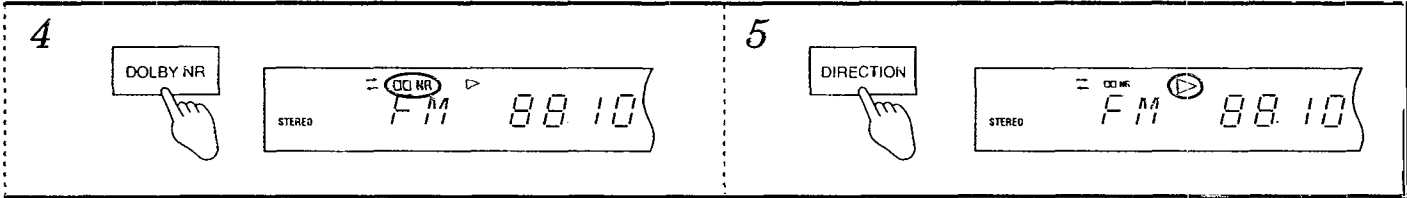

You can record on normal, chrome, and metal tapes.  
**Preparations**  
 Wind the leader of the tape forward till ready for recording.

- 1 Press POWER.
- 2 Press CONTROL ▲ OPEN/CLOSE.  
The front panel will open, exposing the control panel.
- 3 Press TAPE ▲ OPEN/CLOSE once, load a tape and press the button again.  
The holder will close automatically.
- 4 To record in Dolby NR  
Press DOLBY NR and check "□□ NR" is displayed.
- 5 Press DIRECTION to select tape direction.  
Each time the button is pressed, the indicators will change as follows.

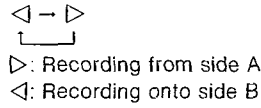

- 6 If the ▷ direction was selected in step 5  
by remote control only  
 Press REVERSE MODE to select the reverse mode.  
 Each time the button is pressed, the indicators will change as follows.  
 ▷ (◁) : The tape automatically stops after recording on one side.  
 ▷ (◁) (◁) : The tape automatically stops after recording on both sides.  
 When recording, if (◁) is selected, the reverse mode automatically changes to ▷ to prevent you from recording over the first side.

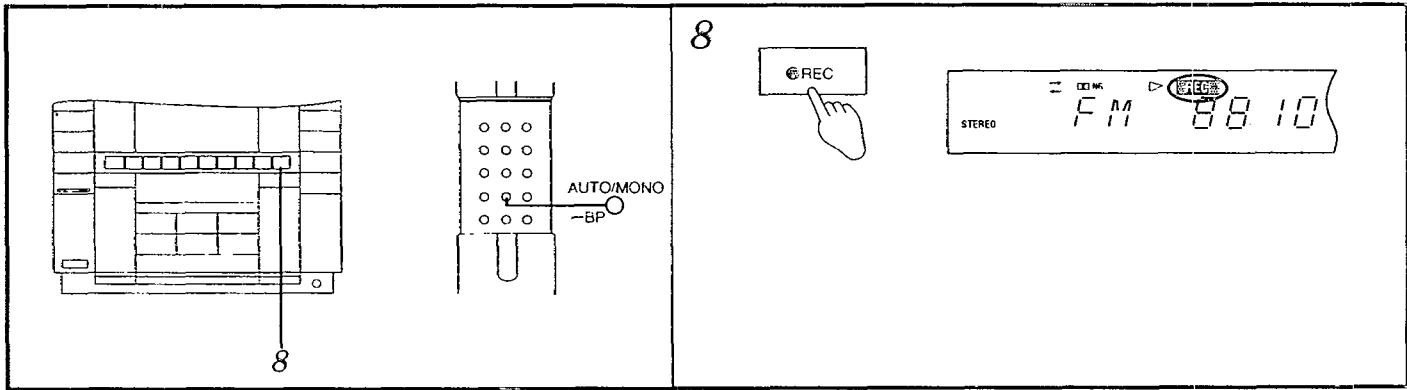

7 Tune in the desired station.

- 8 Press ● REC.  
Recording starts.

**To stop recording**  
 Press ● REC.

**Note**  
 Quality and field effects cannot be recorded.  
**When strong interference disturbs recording of an AM broadcast** by remote control only  
 Hold -BP down for three seconds

Each time the button is pressed, the display will change as follows.  
 MW: BP1 → BP2      LW: BP1 → BP2 → BP3

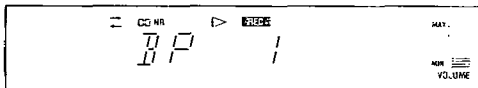

Switch to whichever setting lowers interference best.

**To erase a tape**

- Load a tape and follow the below procedure.
1. Set the source to "TAPE".
  2. Press DOLBY NR and check "□□ NR" goes out.
  3. Press DIRECTION to select tape direction.
  4. If the ▷ direction was selected in step 3, press REVERSE MODE on the remote control, to select the reverse mode  
 ▷ (◁) : To erase only one side  
 ▷ (◁) (◁) : To erase both sides
  5. Press ● REC to start recording.

**Note**  
 Always be sure to turn OFF the soundscape function before recording.

## ■ USING THE TIMER

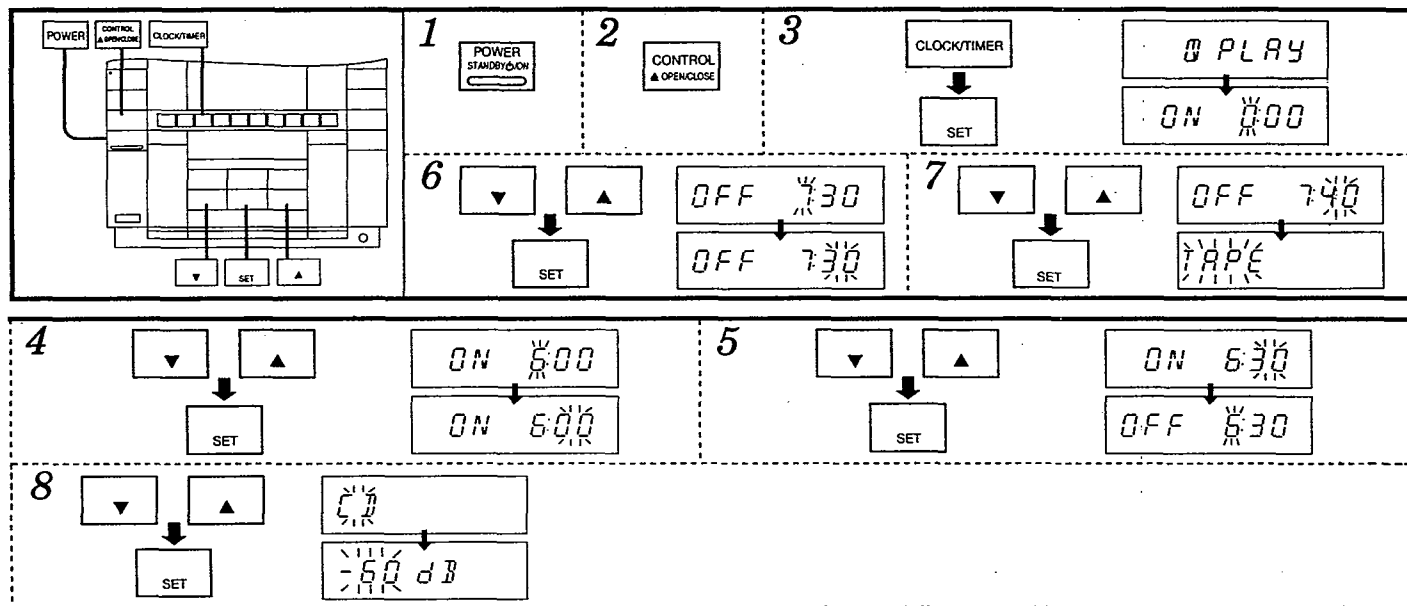

### To use the play timer

Select this timer when you want to use the timer as an alarm clock. You can wake up, listening to music (CD, TUNER, TAPE) at a desired volume and time.

#### Preparations

- Set the time of day.
  - To listen to the radio, memorize the desired station.
  - To listen to a CD or tape, load the necessary medium.
  - You can set alarm clock volume (see step 9).
- Before setting volume, play back the source to determine the best volume.

This example shows how to play the loaded CD every morning between 6:30 and 7:40, at -40dB.

**1** Press **POWER**.

**2** Press **CONTROL OPEN/CLOSE**.

The front panel will open, exposing the control panel.

**3** Press **CLOCK/TIMER** until "**PLAY**" is displayed, and then press **SET**.

**4** Set the starting hour with **▼** and **▲**, and press **SET**.

**5** Set the starting minutes with **▼** and **▲**, and press **SET**.

**6** Set the ending hour with **▼** and **▲**, and press **SET**.

**7** Set the ending minutes with **▼** and **▲**, and press **SET**.

**8** Select the desired source with **▼** and **▲**, and press **SET**.

If "FM", "MW" or "LW" has been selected as the source, immediately after selection, select the desired channel with **▼** and **▲**, and press **SET**.

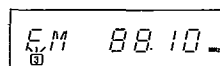

Channel

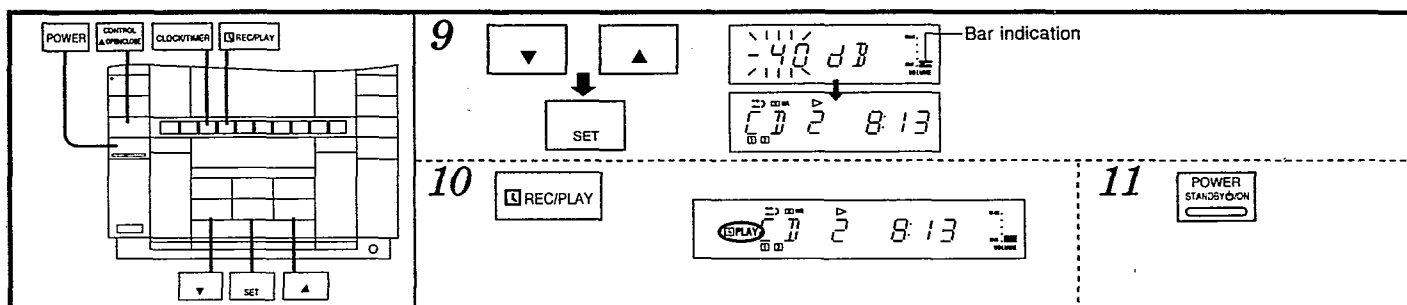

**9** Set the playback volume **▼** and **▲**, and press **SET**.  
The current volume (bar indication) will not change.

**10** Press **REC/PLAY** and check "**PLAY**" is displayed.

**11** Press **POWER** to put your stereo on standby.

When the set time is reached, power will be turned ON and playback will start. As long as "**PLAY**" is displayed, the timer will go off every morning at the same time.

**To check settings (only while power is ON)**

Press CLOCK/TIMER and check "PLAY" is displayed.  
Two seconds later, the display will change in the following order.

- ① Play start time
- ② Play over time
- ③ Play source
- ④ Playback volume

**To change settings (only while power is ON)**

- ① Press REC/PLAY and check "PLAY" goes out.
- ② Reprogram from step 1 on page 26.

**To switch the timer OFF (only while power is ON)**

Press REC/PLAY and check "PLAY" goes out.  
The settings made with the preceding procedure will however be kept in memory.

**To set the timer with soundscape (for playback from CD's and tapes only)**

- ① Follow steps 3–10 on the page 26.
- ② Follow steps 5 and 6 on page 19.
- ③ Follow step 11 on the page 26.

**For your reference**

To set the timer for soundscape playback alone Follow the above procedure but without loading a CD or tape.

**To enjoy the desired source after the timer setting is completed**

Start the desired source after step 10 on page 26.  
The timer will return to the made settings even if volume and source are changed.  
Be sure to put your stereo on standby after playback.

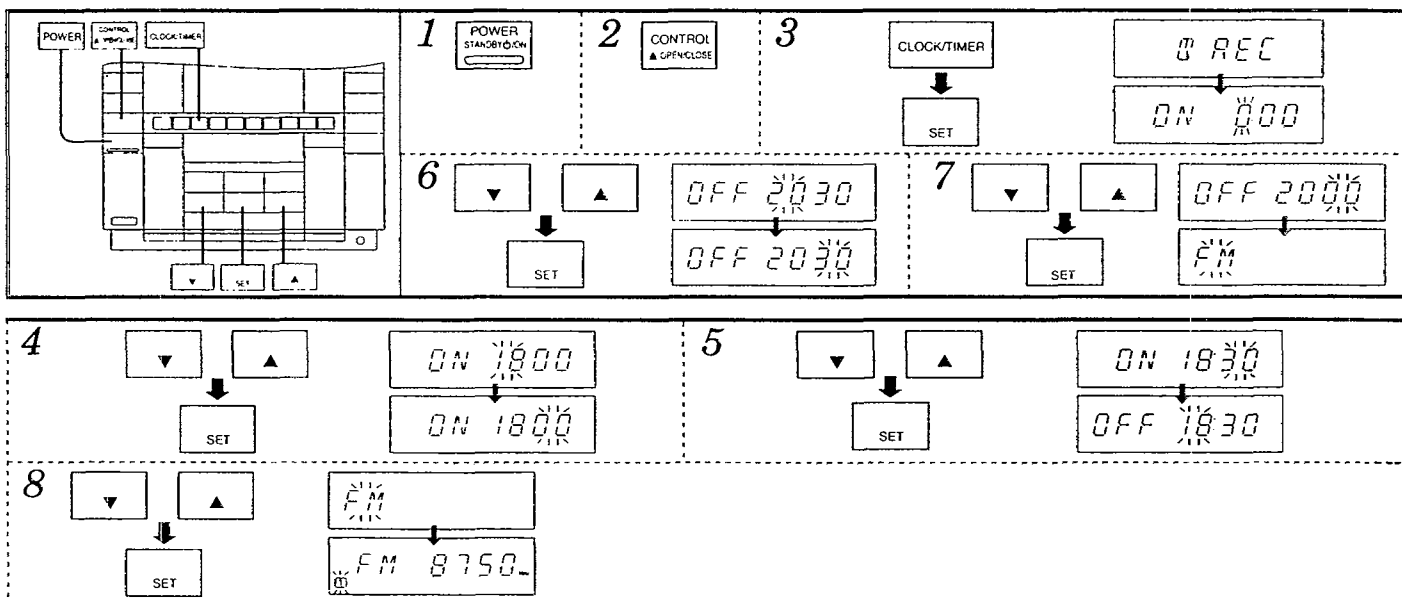
**To use the record timer**

Select this timer when you want to time-record a midnight program or while you are out. The system will record a desired radio broadcast at a desired time.

**Preparations**

- Set the time of day.
- Memorize the desired station.
- Load a tape and set Dolby NR, tape direction and the reverse mode.

This example shows how to record from the FM station memorized under channel 3, from 18:30 to 20:00.

**1** Press **POWER**.

**2** Press **CONTROL** **▲** **OPEN/CLOSE**.

The front panel will open, exposing the control panel.

**3** Press **CLOCK/TIMER** until "**REC**" is displayed, and then press **SET**.

**4** Set the starting hour with **▼** and **▲**, and press **SET**.

**5** Set the starting minutes with **▼** and **▲**, and press **SET**.

**6** Set the ending hour with **▼** and **▲**, and press **SET**.

**7** Set the ending minutes with **▼** and **▲**, and press **SET**.

**8** Select "**FM**", "**MW**" or "**LW**" with **▼** and **▲**, and press **SET**.

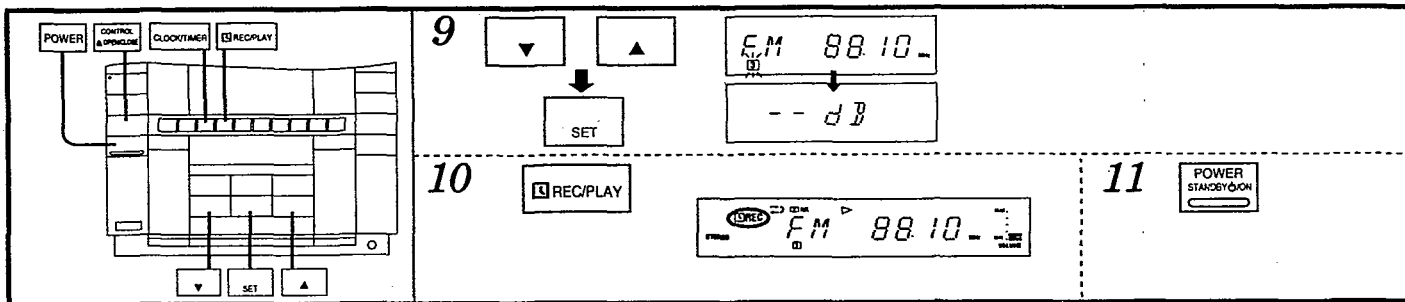

**9** Select the desired channel with ▼ and ▲, and press SET.

**10** Press **REC/PLAY** until **REC** is displayed. Each time the button is pressed, the indication will change as follows.

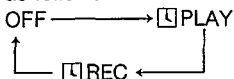

**11** Press **POWER** to turn put your stereo on standby. When the set time is reached, power will be turned ON and recording will start. Sound is automatically muted.

**When the set time is over**  
**REC** goes out and the timer mode is turned OFF.

**To check settings (only while power is ON)**  
 Press **CLOCK/TIMER** and check "**REC**" is displayed. Two seconds later, the display will change in the following order.  
 ① Recording start time  
 ② Recording over time  
 ③ Station to be recorded  
 ④ Volume level during operation [The lowest volume (— dB) will be displayed.]

**To change settings (only while power is ON)**  
 ① Press **REC/PLAY** and check "**REC**" goes out.  
 ② Reprogram from step 1 on page 27.

**To switch the timer OFF (only while power is ON)**  
 Press **REC/PLAY** and check "**REC**" goes out.

**To record the same broadcast the following day**  
 ① Press **REC/PLAY** and check "**REC**" is displayed.  
 ② Press **POWER** to put your stereo on standby.

**To enjoy the desired source after the timer setting is completed**  
 Start the desired source after step 10 on the page 28. The timer will return to the made settings even if volume and source are changed. After playback is over, check a blank tape is loaded into the tape deck and be sure to put your stereo on standby.

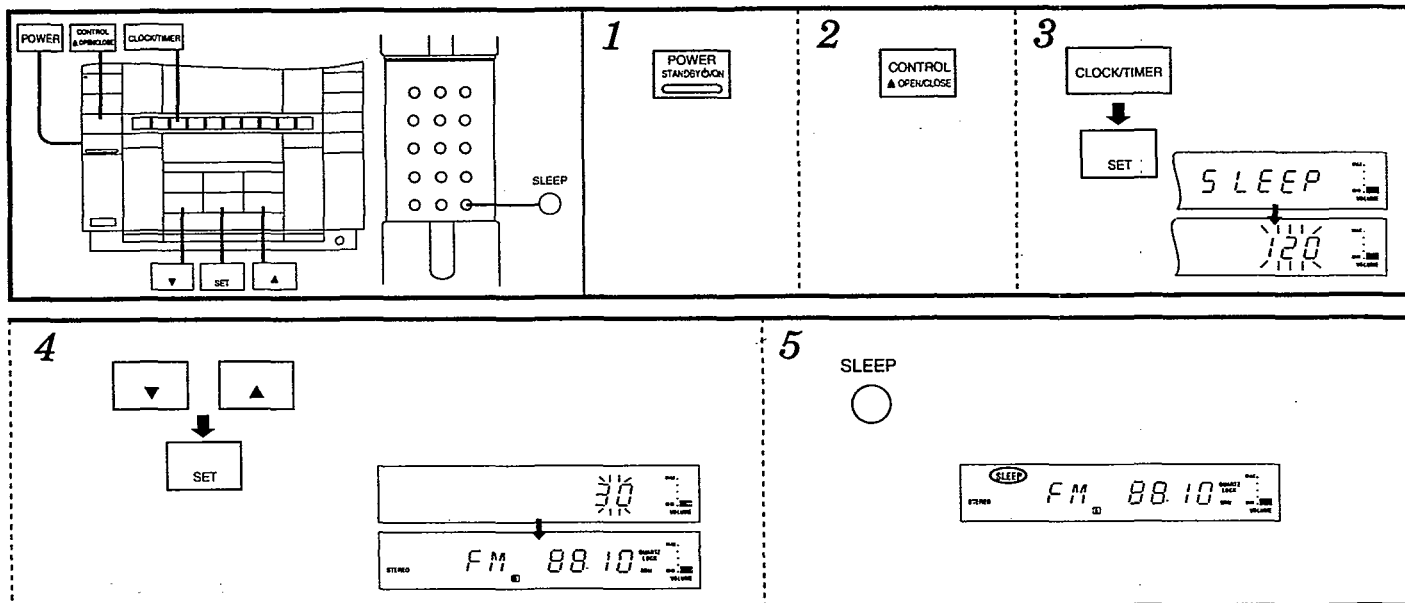

## To use the sleep timer

Select this timer when you want to switch off the music automatically as you fall asleep.

The system will go on standby when the preset amount of time has passed.

The timer can be set to a maximum 120 minutes.

### Preparations

Start playback from the desired source.

This example shows how to put your stereo on standby in 30 minutes while listening to an FM station

- 1 Press **POWER**.
- 2 Press **CONTROL**  $\blacktriangle$  **OPEN/CLOSE**.  
The front panel will open, exposing the control panel.
- 3 Press **CLOCK/TIMER** until "SLEEP" is displayed, and then press **SET**.
- 4 Set the desired times with  $\blacktriangledown$  and  $\blacktriangle$ , and press **SET**.
- 5 Press **SLEEP** on the remote control.

Be sure to check "SLEEP" is displayed.

When the set time has elapsed, your stereo will be automatically put on standby.

### To change the time setting

Follow procedure from step 3.

You can skip step 5 if "SLEEP" is displayed.

### To cancel the sleep timer

**by remote control only**

Press **SLEEP** and check "SLEEP" goes out.

### Note!

The sleep timer turns OFF automatically the moment you attempt to edit-record a CD.

## To use two timers together

The sleep timer can be used in conjunction with the play timer or record timer.

### Play timer and sleep timer

To go to sleep listening to an FM broadcast, and wake up the next morning listening to a compact disc,

- ① Program a CD for play timer.  
Follow steps 1–10 on page 26.
- ② Tune in the desired band and station, and adjust the volume.  
See pages 17, 18.
- ③ Set the sleep timer  
Follow steps 3–5 on pages 28, 29.

Volume of the play timer does not change if volume of the sleep timer is changed.

### Record timer and sleep timer

To go to sleep listening to a compact disc, and then to make a timer recording from a radio broadcast.

- ① Program the record timer  
Follow steps 1–10 on pages 27, 28.
- ② Start CD playback  
See pages 13–15.
- ③ Set the sleep timer  
Follow steps 3–5 on pages 28, 29.

### Note!

Be sure to set the sleep timer to off before the timer recording begins.

### Timer priority

Priority is given in the order of sleep timer, record timer, play timer when preset times overlap.

Be sure not to overlap timer settings.

## LISTENING TO AN EXTERNAL SOURCE OR WITH HEADPHONES

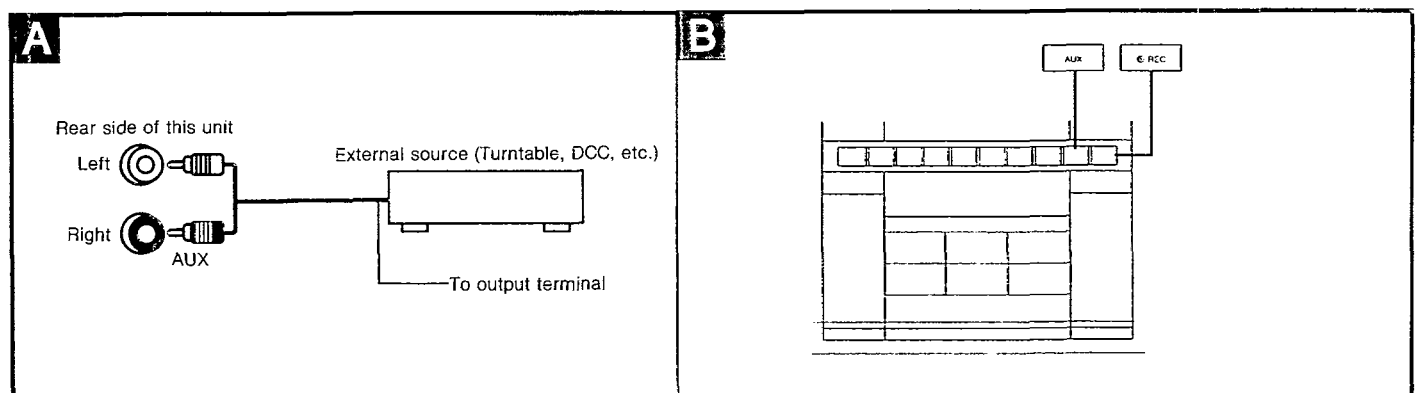

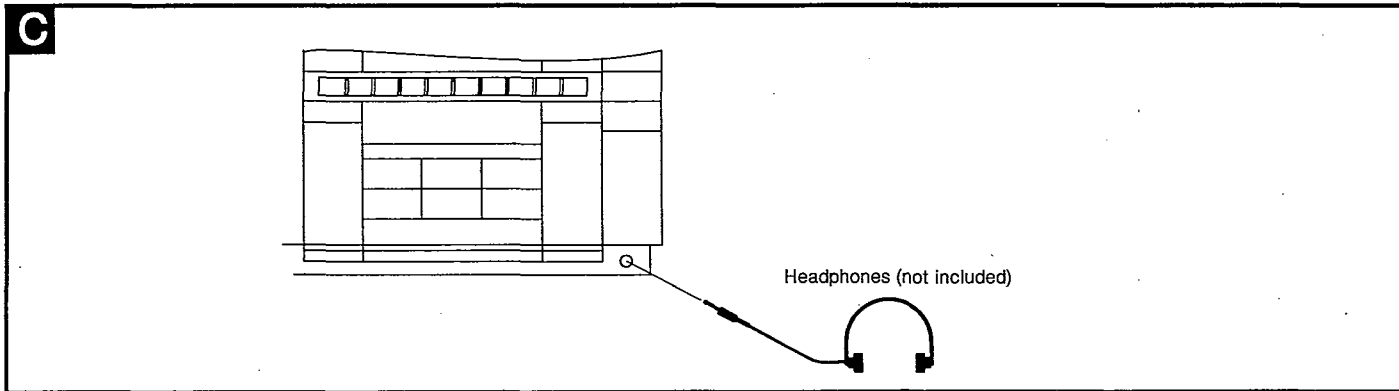

### Connecting to an external source **A**

#### For your reference

This stereo can be connected to a turntable, but only if it is equipped with a built-in phonoequalizer.

### Listening to an external source **B**

1. Press AUX.
2. Start playback from the external source. (For details, refer to the owner's manual of the equipment.)

### Recording from an external source **B**

1. Follow steps 4–8 on page 22.
2. Press AUX.
3. Press ● REC (recording starts).
4. Start playback from the external source. (For details, refer to the owner's manual of the equipment.)

#### To stop recording

Press ● REC.

### To use headphones **C**

Connect the headphones to the headphones jack.

- Before connecting, reduce the volume.
- Avoid listening for prolonged periods of time to prevent hearing damage.
- Plug type: Stereo mini

## MAINTENANCE

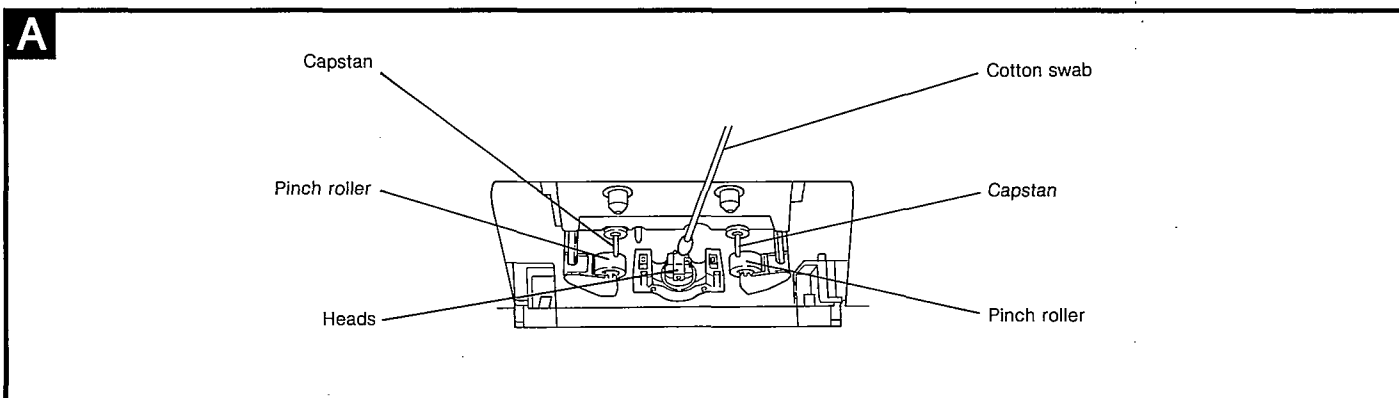

### Outer maintenance

To clean this unit, use a soft, dry cloth. If the surfaces are extremely dirty, use a soft cloth dipped in a soap-and-water solution or a weak detergent solution.

Wring the cloth well before wiping the unit.

Wipe once again with a soft, dry cloth.

Never use alcohol, paint thinner, benzene, or chemically treated cloths to clean this unit. Such chemicals may damage the finish of your system.

### Tape head care **A**



To assure sound quality for recording and playback, be sure to clean the tape heads after approximately every 10 hours of use.

1. Open the cassette holder.
2. Unplug the stereo from its outlet. If power is put on standby at the POWER switch, the cassette holder will close.
3. Clean the tape heads, pinch rollers and the capstan shafts with a cotton swab (or a soft, lint-free cloth) slightly moistened with isopropyl alcohol. Do not use any solution other than alcohol for head cleaning.

# QUICK REFERENCE OF REMOTE CONTROL OPERATIONS

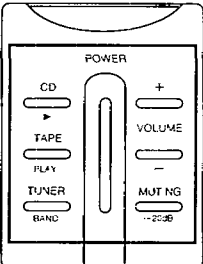
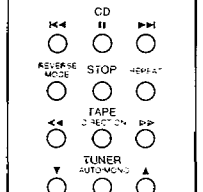
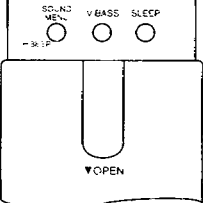
Reference pages indicated in black circles. Unless indicated otherwise, buttons function as with the stereo control panel.

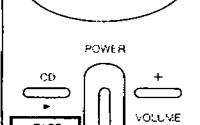
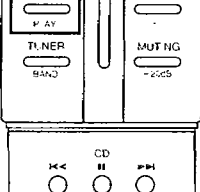
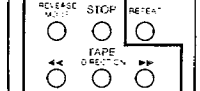
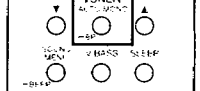
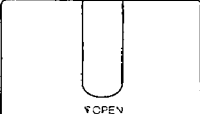
Common operation	
	<p>Switches the stereo ON or places it on standby</p> <p>Adjusts the volume</p> <p>Mutes the volume temporarily (21)</p>
	<p>Selects the input source When on standby, playing starts with one-touch of any of these buttons. (21)</p>
	<p>Adjusts the volume</p>
	<p>Mutes the volume temporarily (21)</p>

Tape deck operation	
	<p>Starts playback</p>
	<p>Selects the reverse mode (16)</p>
	<p>Fast forwards or rewinds the tape (only when stopped) Finds the beginning of a track (during playback) (TPS function)</p>
	<p>Selects tape direction</p>
	<p>Stops playback</p> <p><b>Note</b> As a consequence, when recording, the tape will be stopped after the CD stops.</p>
	<p>Stops playback</p>
	<p>When strong interference disturbs recording of an AM broadcast (25) (Hold down for about 3 seconds)</p>

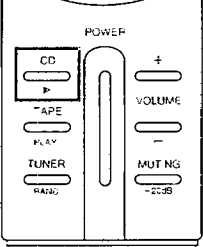
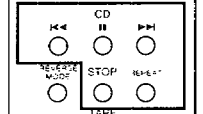
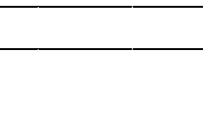
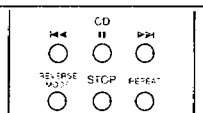
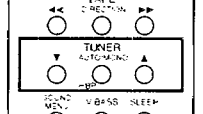
CD player operation	
	<p>Starts play</p>
	<p>Skips tracks</p>
	<p>Repeats play (16)</p>
	<p>Temporarily stops play (14)</p>
	<p>Stops play</p>

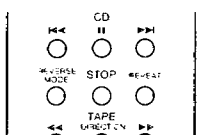
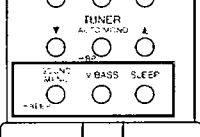
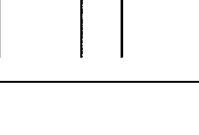
Sound quality/Sound field/Sleep timer	
	<p>Selects sound quality and field Hold down to turn OFF the beep.</p>
	<p>Adds bass</p>
	<p>Turns the sleep timer ON/OFF (29)</p>

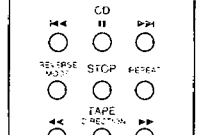
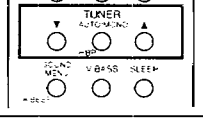
Tuner operation	
	<p>Tune-in a programmed station</p>
	<p>Switches between FM stereo mode and monaural (18)</p>

# SELF-DIAGNOSTIC FUNCTION

## • SELF-DIAGNOSTIC DISPLAY

This unit has a self-diagnostic function to indicate malfunctions. You should take full advantage of this function when performing maintenance.

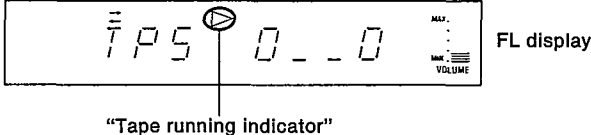
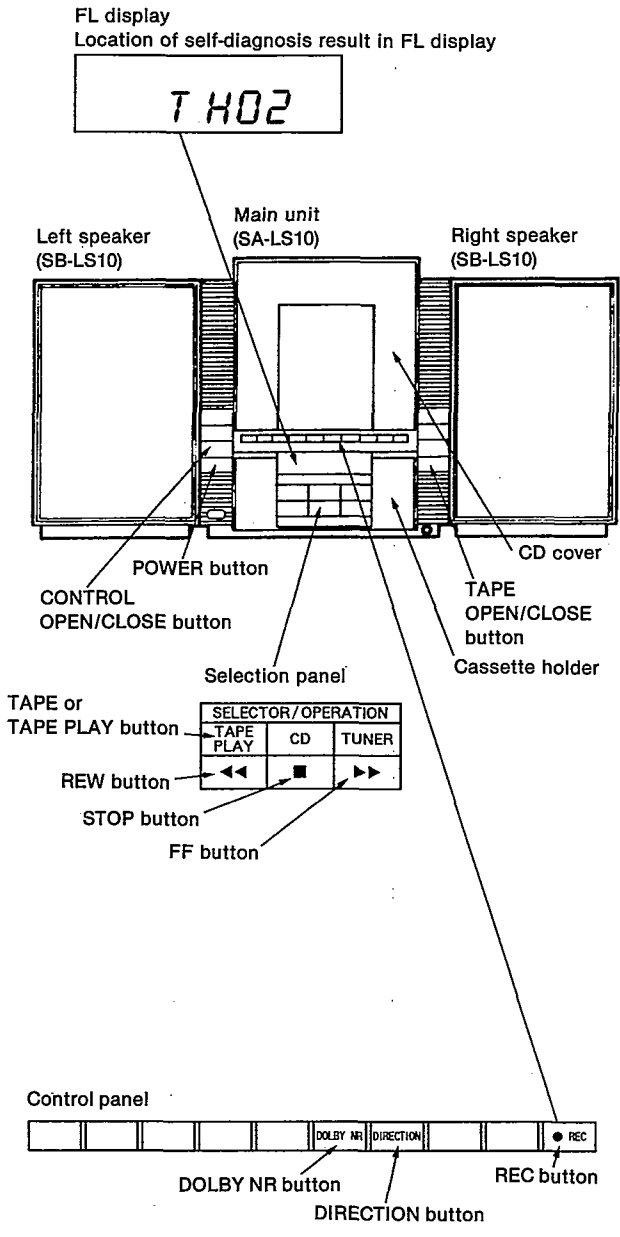
Procedure	Display location
<p><b>To display self-diagnosis results:</b></p> <ul style="list-style-type: none"> <li>• <b>For error codes H01, H02, H03, F01 and F02</b> <ol style="list-style-type: none"> <li>1. Press the CONTROL OPEN/CLOSE button to open the control panel. The CD cover will lift slightly.</li> <li>2. Press the TAPE button on the selection panel until TAPE PLAY is indicated.</li> <li>3. Load a cassette in the tape deck. Metal, chrome or normal tape may be used.</li> <li>4. Press the DIRECTION button on the control panel to activate the "tape running" indicator in the FL display, as shown below. Remove the cassette.</li> </ol>  <ol style="list-style-type: none"> <li>5. With no cassette in the deck, press the DOLBY NR button for at least 2 seconds, then hold it down as you press the STOP button for at least 2 more seconds.</li> <li>6. "T" will appear in the FL display, indicating that the unit has entered self-diagnosis mode.</li> <li>7. Load a metal tape with the protective tab on the left side of the cassette (as you look at it) broken off. Then close the cassette holder. (Use the tape which is rewinded for about 10 seconds.)</li> <li>8. Press the FF button to fast forward the cassette for about 2 seconds until it stops automatically. Remove the cassette.</li> <li>9. Load a metal tape with the protective tab on the right side of the cassette (as you look at it) broken off. Close the cassette holder.</li> <li>10. Press the REW button to rewind the cassette for about 2 seconds until it stops automatically. Remove the cassette.</li> <li>11. Load a chrome music tape with the protective tabs unbroken and close the cassette holder.</li> <li>12. Press the TAPE PLAY button to start the TPS* (tape program search) function and stop it automatically. Remove the cassette.</li> <li>13. Load a normal tape with the protective tabs unbroken and close the cassette holder.</li> <li>14. Press the REC button.</li> <li>15. Press the STOP button to indicate any fault that has occurred. If more than one fault has occurred, each will be shown in turn by successive presses of the STOP button. If there were no faults, "T" remains in the FL display.</li> </ol> <ul style="list-style-type: none"> <li>• <b>For error codes F03 and F61</b> Any fault is automatically indicated in the FL display. (Three seconds later, the power is turned off automatically, and only a time clock is displayed.)</li> </ul> </li> </ul>	<p><b>Display location</b></p> <p>FL display Location of self-diagnosis result in FL display</p> 



### Procedure

#### To resume normal display:

1. For error codes H01, H02, H03, F01, F02 and F03
  - Press the POWER button once to turn off the power and once more to turn it on again.
2. For error code F61
  - The power will remain off until the fault is fixed.

#### To display self-diagnosis results again:

1. For error codes H01, H02, H03, F01, F02 and F03
  - Repeat step 1, 2 and 5 in the original procedure.
2. For error code F61
  - When the power is turned on, "F61" is displayed for 3 seconds. Then the power is turned off automatically, and only a time clock is displayed.

#### Note:

- Fault indications are stored in memory, and must be cleared from it when the fault has been fixed. To do this, keep the STOP button pressed for at least 5 seconds while the self-diagnosis result is displayed. "CLEAR" will appear in the FL display for 1 second and the "T" replace it.
- Then turn off the power.

### Interpretation of error codes

Error code	Symptom/status	Remedy
H01	The cassette mechanism has a malfunction. For example, pressing the FWD PLAY button results in reverse playing.	The cassette mechanism mode switch (S971) and plunger are defective. Check and/or replace them.
H02	The machine will not record, or records even on a tape whose protective tab has been broken off.	The erasure prevention switches (S974 and S975) are not making contact or are short circuited. Check and/or replace them.
H03	Pressing the TAPE PLAY button fails to play the tape. Pressing the TAPE PLAY button causes the motor to rotate even when no cassette is loaded.	The cassette half-open detection switch (S972) is not making contact or is short circuited. Check and/or replace it.
F01	When the TAPE PLAY button is pressed, the tape runs for a short time and then stops.	The hole detection IC (IC971) is defective, causing a faulty reel pulse. Check and/or replace the IC.
F02	The TPS* (tape program search) function does not work.	The PLAY EQ/recording amp IC (IC201) is defective. Check and/or replace it.
F03	Pressing the REC button makes the TAPE PLAY, FF and REW buttons inoperative.	The reel motor is defective. Check and/or replace it.
F61	The power is turned off automatically soon after the POWER button is set to ON. ("F61" is indicated for 3 seconds and then the display changes to a time clock.) The speaker output IC is defective, causing a DC voltage to develop at the speaker terminal.	The speaker output IC (IC501) is defective. Check and/or replace it.

#### \*TPS

The TPS (tape program search) function detects breaks in the recorded sound between tracks on a tape. This function should not be used with the following sorts of music tape.

- Tapes in which the intervals between tracks are less than 4 seconds.
- Tapes with no periods of complete silence (e.g. those recorded using a microphone).
- Tapes featuring unusually low volumes of sound in parts (e.g. some classical music).
- Tapes with tracks that last less than 10 seconds.
- Tapes in which music fades in or out.

## ■ SOUNDSCAPE

This unit has a "Soundscape" function that produces three natural sound effects: a murmuring stream, waves on a beach and birds in a forest.

### • SOUNDSCAPE OUTLINE

Pressing the SOUNDSCAPE button on the main unit lets you select a natural sound effect (stream, beach or forest). The sound effects change according to the time of day: morning (6 : 00~11 : 59 hrs), afternoon (12 : 00~17 : 59 hrs) or night (18 : 00~5 : 59 hrs).

Example: In the morning the forest is filled with the calls of cuckoos, while at night the hoots of owls and the chirping of crickets are to be heard.

Note: The natural sound effects change according to the time set on the clock. If a time is not set, they switch automatically to those heard in the afternoon.

**Table 1. Soundscape effects**

The table below shows the natural sound effects heard at each time of day.

Mode		Basic sound	Additional sound 1	Additional sound 2	Additional sound 3	Additional 4 sound
Stream	Morning	Stream A Stream B Stream C	Coal tit (bird)	Willow tit (bird)	Gray thrush (bird)	Cuckoo
	Afternoon		Coal tit	Willow tit	Gray thrush	Great tit (bird)
	Night		"Bell-like" cricket	Owl	Cricket	
Beach	Morning	Large wave Medium-size wave Small wave Ebbing wave	Bird 2	Bird 3	Bird 4	Seagull
	Afternoon		Seagull	Bird 5	Bird 1	
	Night					
Forest	Morning	Olive-backed pipit (bird) Nuthatch (bird) Chiffchaff (bird)	Cuckoo	Coal tit (bird)	Gray thrush	Great tit
	Afternoon		Bush warbler (bird)	Coal tit	Brown-necked bulbul (bird)	Gray thrush
	Night		"Bell-like" cricket	Owl	Nightjar (bird)	Cricket

Birds 1~5 are other species of birds.

**Table 1**

### Natural sound effect configuration (see Table 1)

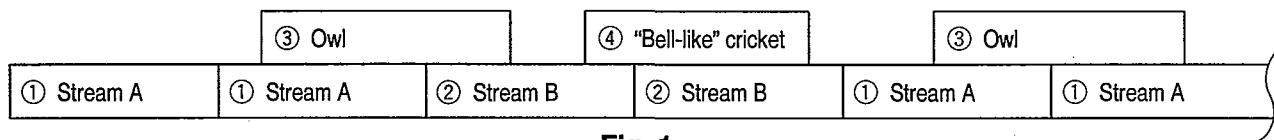

**Fig. 1**

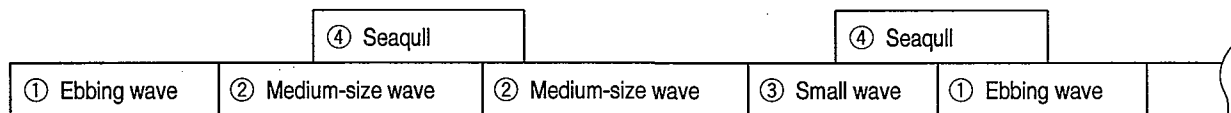

**Fig. 2**

- Figure 1 gives one example of a stream at night. (1), (2), (3) and (4) represent three sounds blended into one effect. (1) and (2) are basic sounds, and (3) and (4) are additional sounds. Against the background of streams A and B, the hoots of owls and chirps of crickets recreate the authentic sound of a stream at night.
- Figure 2 gives one example of a beach in the morning. (1), (2) and (3) are basic sounds and (4) is an additional sound. Against the background of small and medium-size waves, the calls of seagulls recreate the authentic sound of a beach in the morning.
- The individual components of each sound effect are combined by means of random numbers, so the pattern is changing all the time.

### • System block diagram

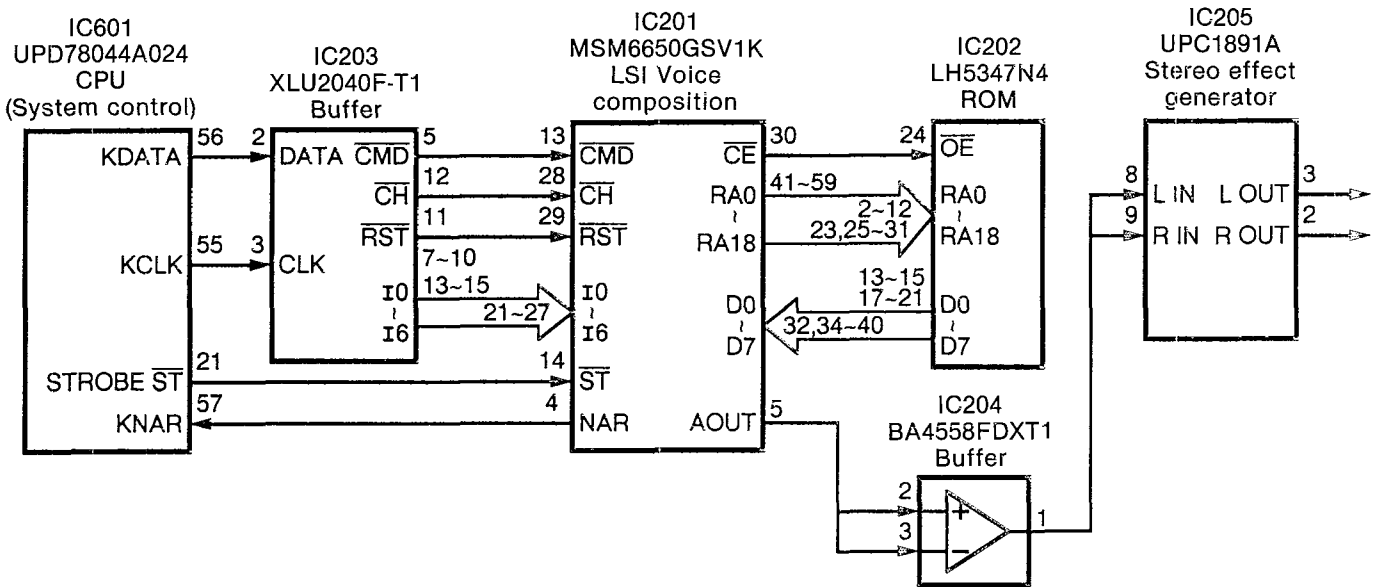

- The CPU (IC601) inputs a command signal to the ST terminal (pin 14) of the LSI voice composition (IC201) to initiate sound synthesis. The ST terminal can only receive command signals from the CPU when its KNAR terminal (pin 4) is driven high.
- Command signals to select one of the Soundscape modes (stream, beach and forest) are sent from the KDATA terminal (pin 56) of the CPU to terminals I0~I6 (pins 21~27) of the LSI voice composition via the buffer (IC203).
- Output signals controlling reading from the ROM (IC202) go from the CE terminal (pin 30) of the LSI voice composition to the ROM's OE terminal (pin 24). The OE terminal can only instigate a read operation from ROM when it has been driven low.
- Output signals designating an address containing data to be read go from RA terminals 0~18 (pins 41~59) of the LSI voice composition to RA terminals 0~18 (pins 2~12, 23 and 25~31) of the ROM.
- Data specifying the components of the selected sound effect are output from terminals D0~D7 (pins 13~15 and 17~21) of the ROM to terminals D0~D7 (pins 32 and 34~40) of the LSI voice composition.
- The LSI voice composition processes these data and outputs a monaural signal from its Audio OUT terminal (pin 5).
- The stereo effect generator (IC205) receives the monaural signal through both its L IN and its R IN terminals (pins 8 and 9) and outputs a stereo signal from its L OUT and R OUT terminals (pins 3 and 2).

## ■ HANDLING PRECAUTIONS FOR TRAVERSE DECK

The laser diode in the traverse deck (optical pickup) may break down due to potential difference caused by static electricity of clothes or human body.

So, be careful of electrostatic breakdown during repair of the traverse deck (optical pickup).

### • Handling of traverse deck (optical pickup)

1. Do not subject the traverse deck (optical pickup) to static electricity as it is extremely sensitive to electrical shock.
2. To prevent the breakdown of the laser diode, an antistatic shorting pin is inserted into the flexible board (FPC board).  
When removing or connecting the short pin, finish the job in as short time as possible.
3. Take care not to apply excessive stress to the flexible board (FPC board).
4. Do not turn the variable resistor (laser power adjustment). It has already been adjusted.

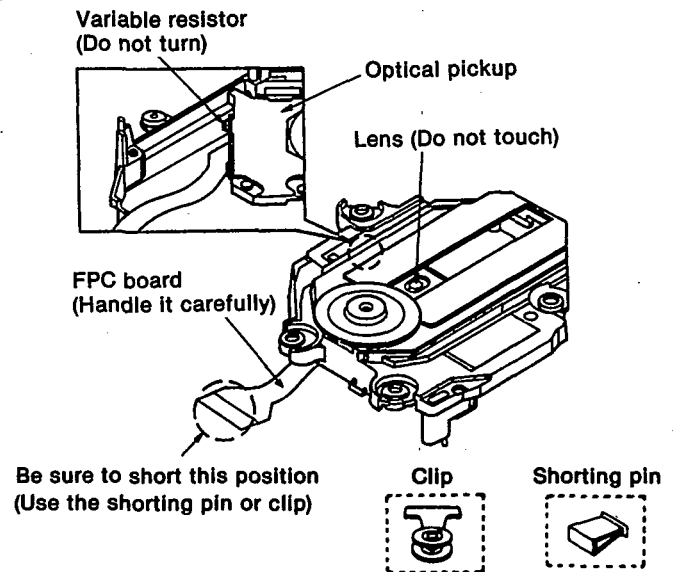

### • Grounding for electrostatic breakdown prevention

1. **Human body grounding.**  
Use the anti-static wrist strap to discharge the static electricity from your body.
2. **Work table grounding**  
Put a conductive material (sheet) or steel sheet on the area where the optical pickup is placed, and ground the sheet.

#### Caution:

The static electricity of your clothes will not be grounded through the wrist strap. So, take care not to let your clothes touch the traverse deck (optical pickup).

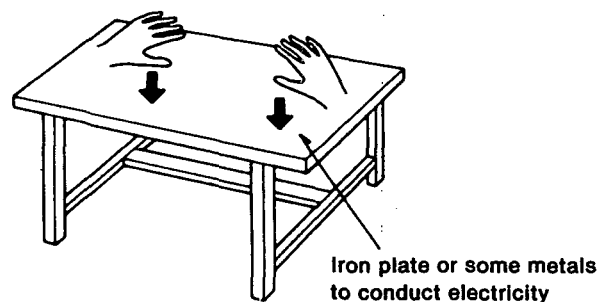
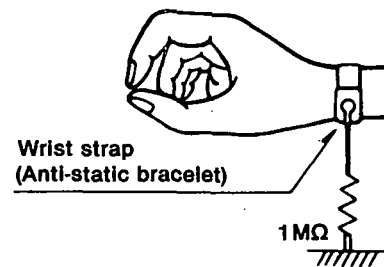

## ■ OPERATION CHECKS AND MAIN COMPONENT REPLACEMENT PROCEDURES

**NOTE** 1. This section describes procedures for checking the operation of the major printed circuit boards and replacing the main components.

2. For reassembly after operation checks or replacement, reverse the respective procedures. Special reassembly procedures are described only when required.

3. Select items from the following index when checks or replacement are required.

4. Illustrated screws are equivalent to actual size.

5. Refer the parts No. on the page of "Main component Replacement Procedures", if necessary.

### ● Contents

•Checking Procedure for each P.C.B.	page.
1.Checking for the main P.C.B.,tuner P.C.B. and mechanism control P.C.B	38.
2.Checking for the power supply P.C.B.	39.
3.Checking for the servo P.C.B.	40.
4.Checking for the FL P.C.B.	41,42.
•Main Component Replacement Procedures	
1.Replacement for the power IC and regulator transistor	42.
2.Replacement for the loading motor and motor belt	42.
3.Replacement for the timing belt,CD door ass'y,CD cabinet(Upper) and CD cabinet(Lower)	43~45.
4.Replacement for the head block ass'y and pinch arm unit	45,46.
5.Replacement for the belt,reel motor,capstan motor unit	46,47.
6.Replacement for the solenoid and parts on the mechanism P.C.B.	47,48.

### ● Preparation

For checking the P.C.B., following extension cable should be prepared.

A pair of extension cable  
[RFKZ0048]



## ■ Checking Procedure for each P.C.B.

### 1. Checking for the main P.C.B., tuner P.C.B. and mechanism control P.C.B.

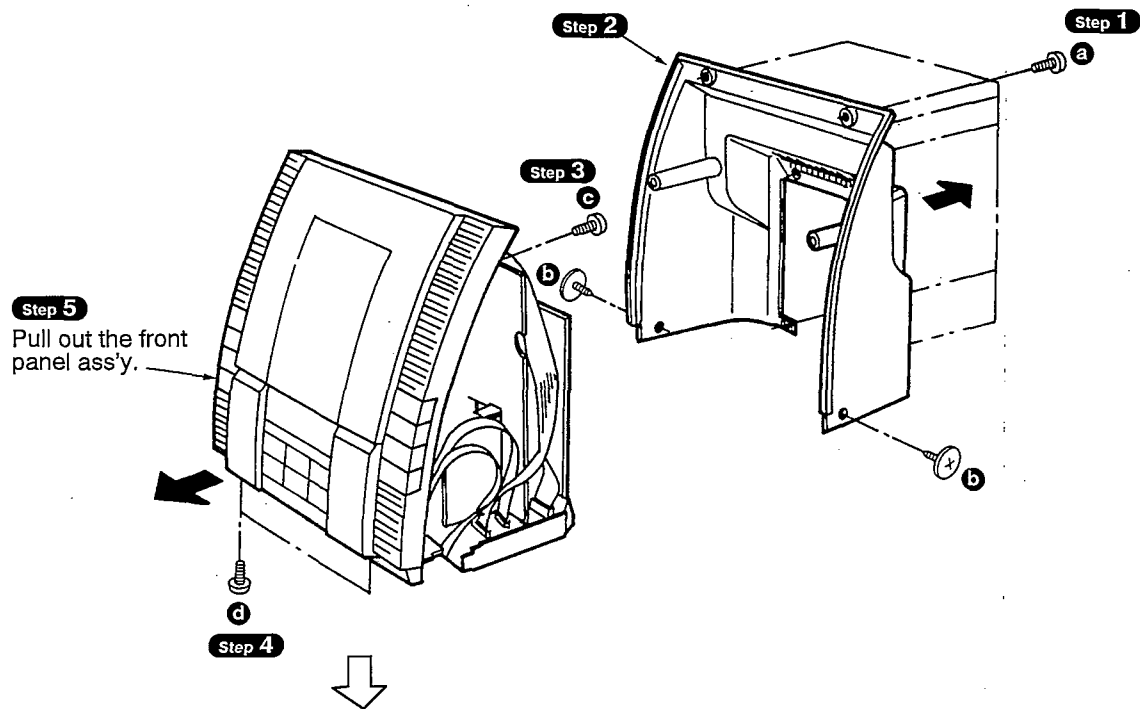

•Check the main P.C.B., tuner P.C.B. and mechanism control P.C.B. and replace the parts as shown below.

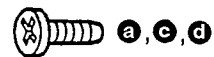
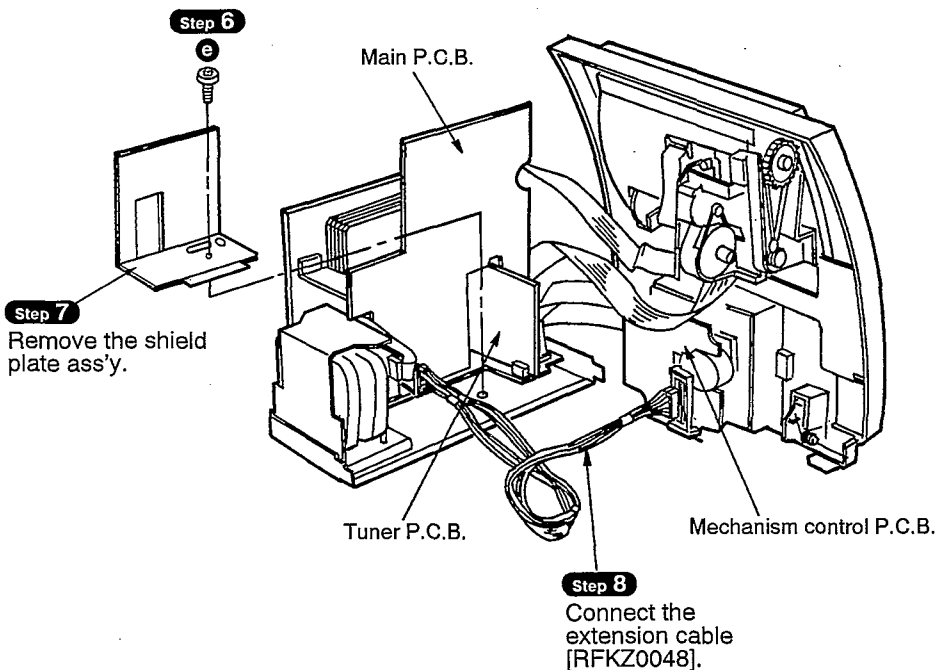

[XTBS3+8JFZ1] (Black)



[RHD30007] (Black)



[XTB3+6FFZ] (Black)

2. Checking for the power supply P.C.B.

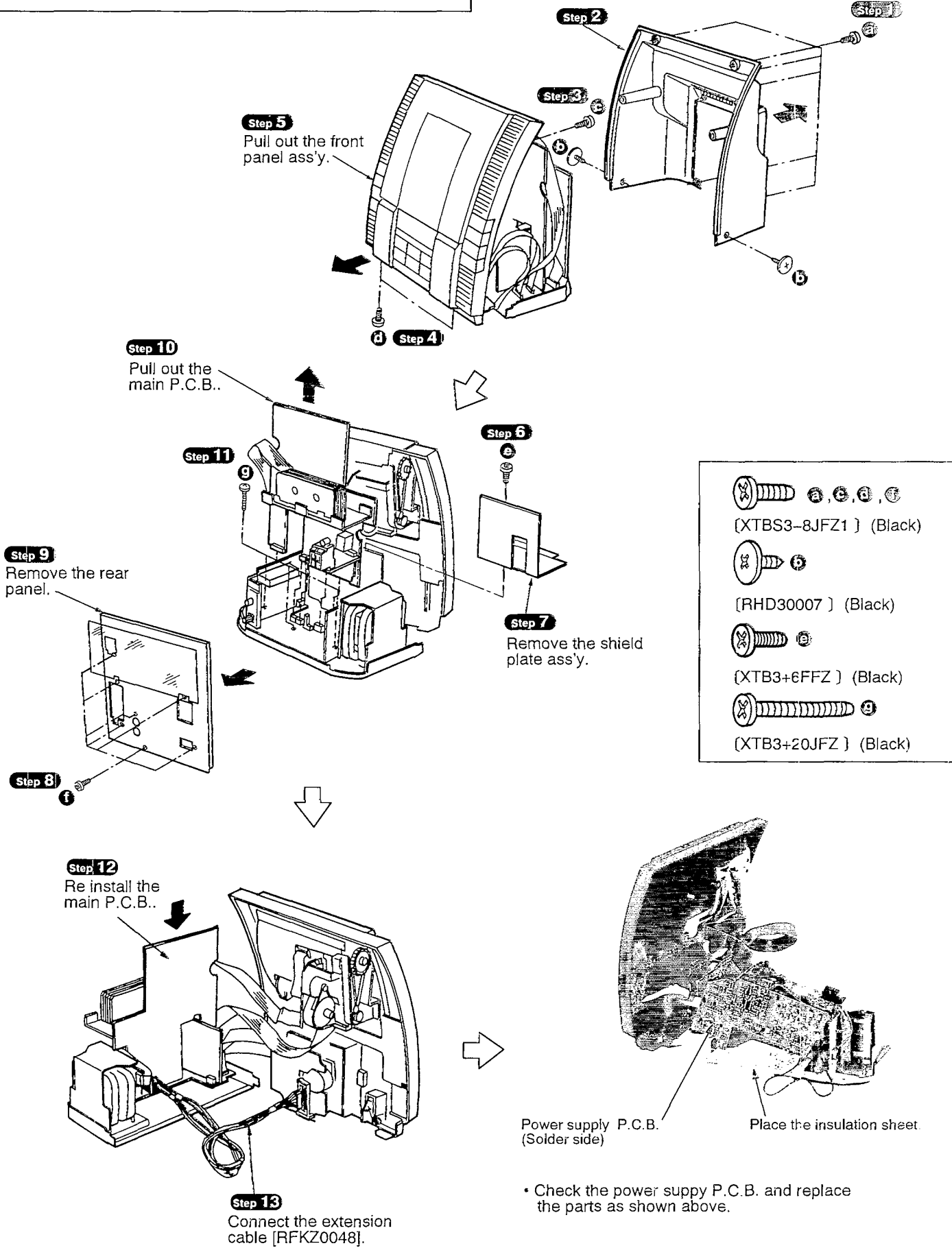

3. Checking for the servo P.C.B.

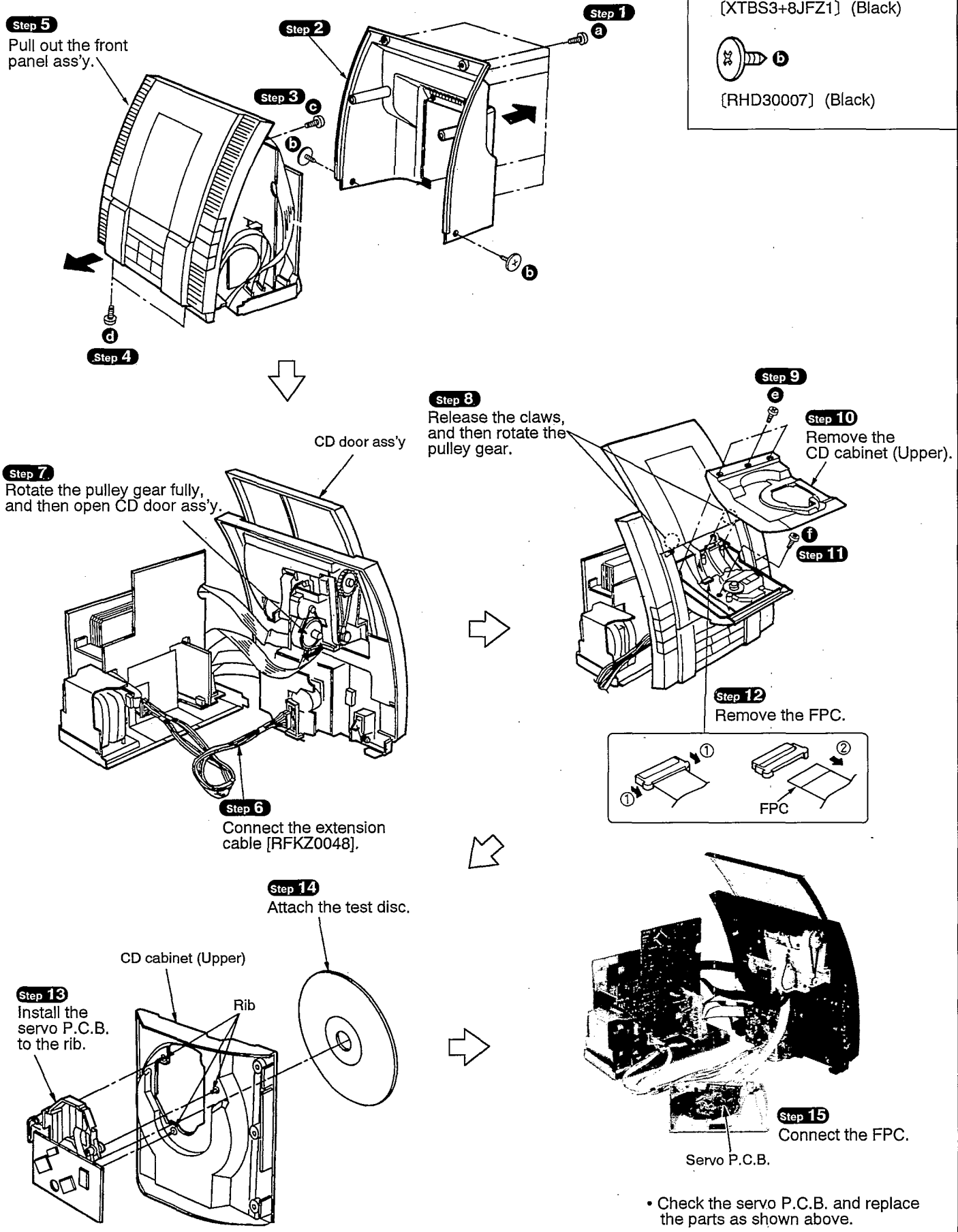

- a, c, d, e, f  
[XTBS3+8JFZ1] (Black)
- b  
[RHD30007] (Black)



• Check the servo P.C.B. and replace the parts as shown above.



4. Checking for the FL P.C.B.

-  a, c, d  
[XTBS3+8JFZ1] (Black)
-  b  
[RHD30007] (Black)
-  e, f, g  
[XTBS26+8J]

**Step 5**  
Pull out the front panel ass'y.

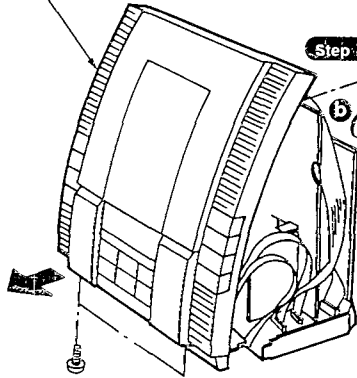

**Step 4**

**Step 2**

**Step 3**

**Step 1**

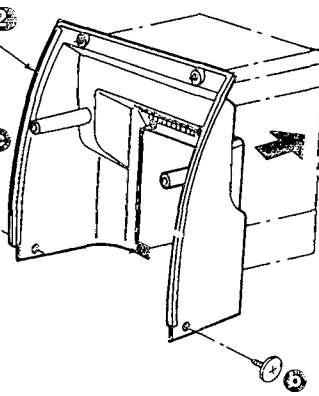

**Step 8**  
Remove the balance spring.

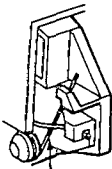

**Step 9**  
Pull out the cassette panel shaft.

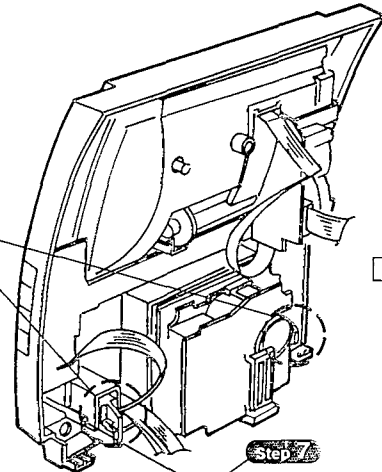
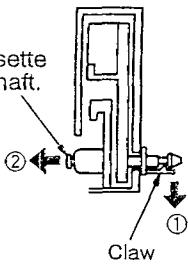

**Step 7**



**Step 10**  
Connect the extension cable [RFKZ0048].

**Step 11**

Push the drive rack.

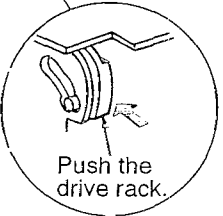

**Step 6**



**Step 12**

Deck panel ass'y

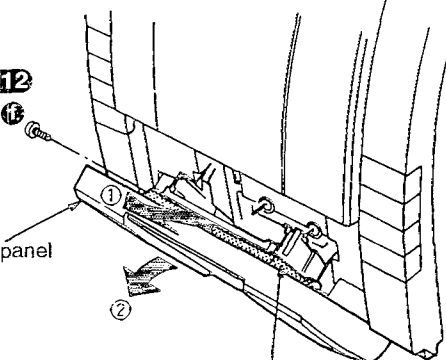

Panel holder

**Step 13**

Lift the panel holder, and then remove the deck panel ass'y.



**Step 15**  
Remove the claws.

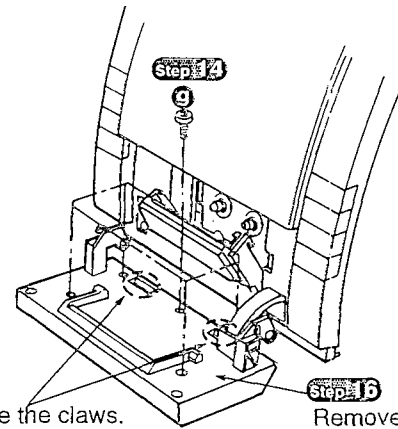

**Step 16**  
Remove the deck rear panel.

To be continued on next page

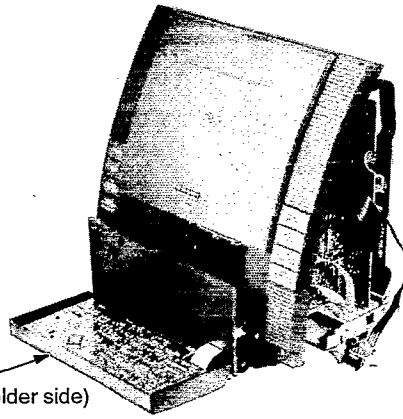

FL P.C.B. (Solder side)

•Check the FL P.C.B and replace the parts as shown below.

## Main Component Replacement Procedures

### 1. Replacement for the power IC and regulator transistor

•Follow the item 2 ( **Step 1** ~ **Step 9** ) in checking procedures for each P.C.B. on page 39.

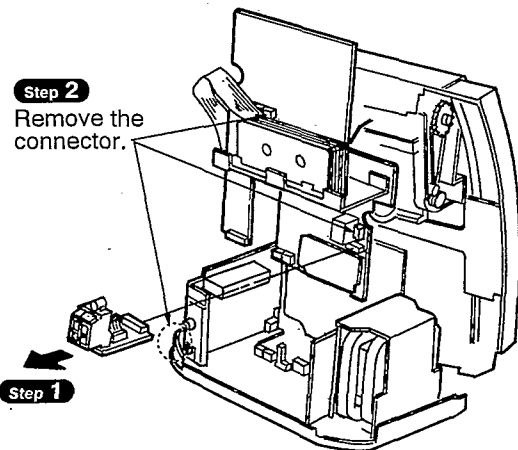

#### NOTE

After replacing the power IC or regulator transistor, apply a sufficient quantity of compound grease (RFKX0002) or equivalent agent between the heat sink and the power IC and regulator transistor.

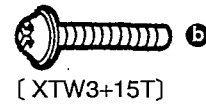
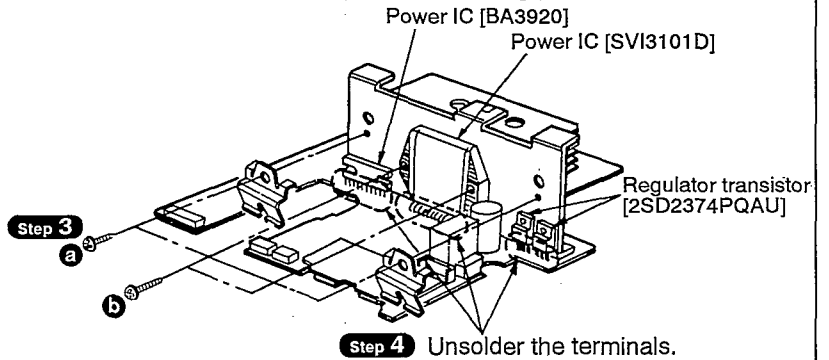

### 2. Replacement for the loading motor and motor belt

•Follow the item 1 ( **Step 1** ~ **Step 5** ) in checking procedures for each P.C.B. on page 38.

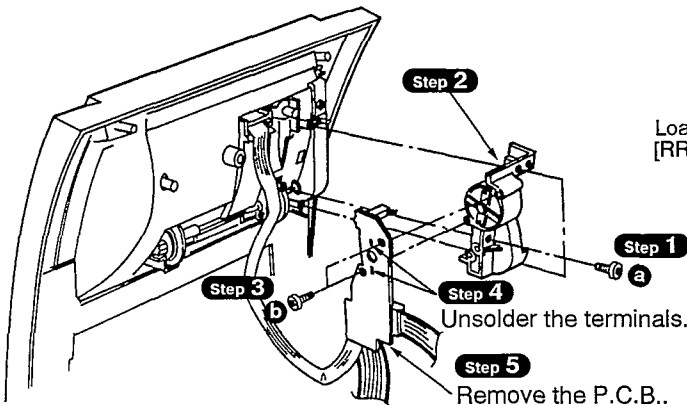

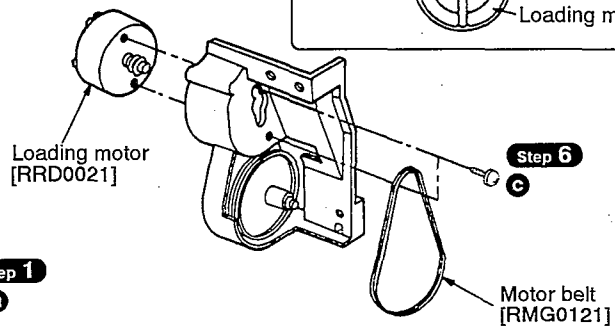
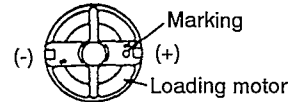

#### Polarity of motor

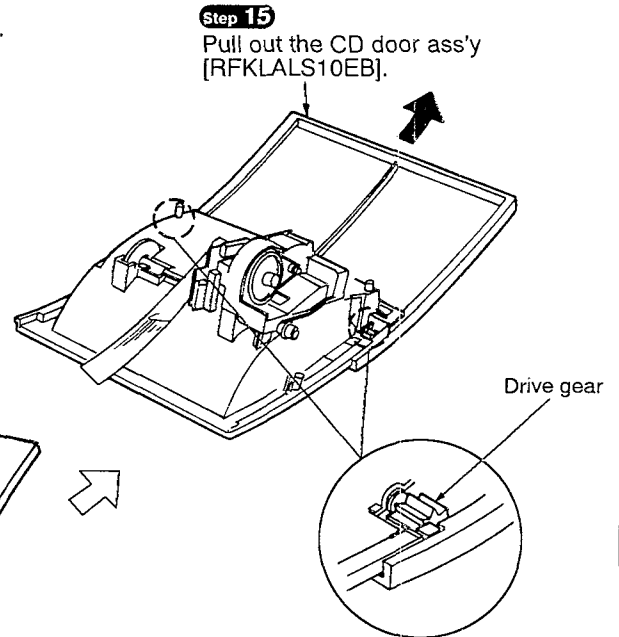
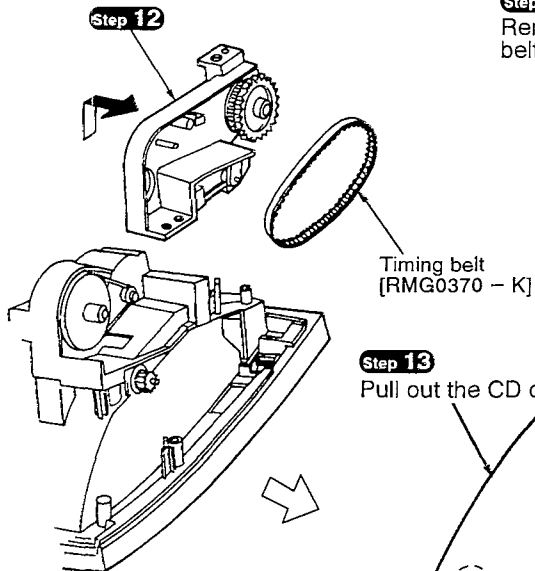
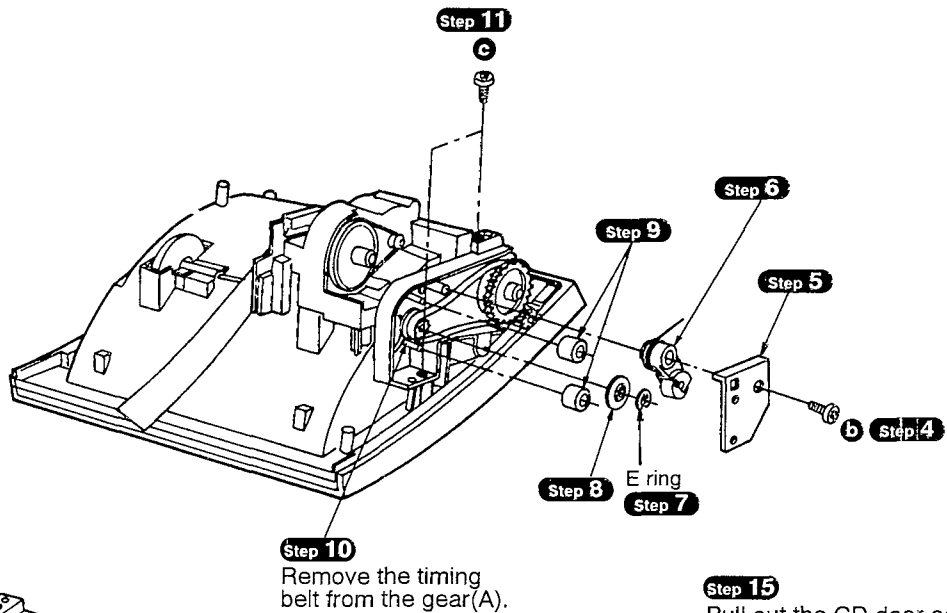
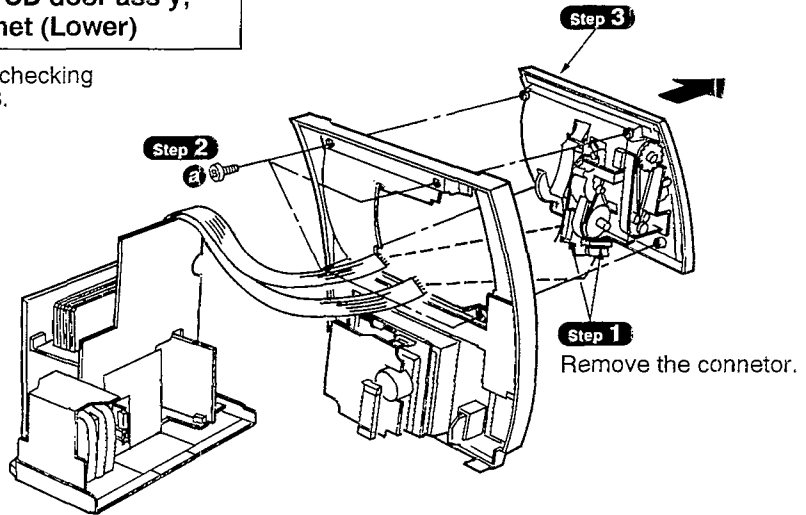

**3. Replacement for the timing belt, CD door ass'y, CD cabinet (Upper) and CD cabinet (Lower)**

•Follow the item 1 ( **Step 1** ~ **Step 5** ) in checking procedures for each P.C.B. on page 38.



 a, b, c  
[XTB3+8JFZ] (Black)

**NOTE**

Even if the drive gear is not easy to be removed, pull out the drive gear.

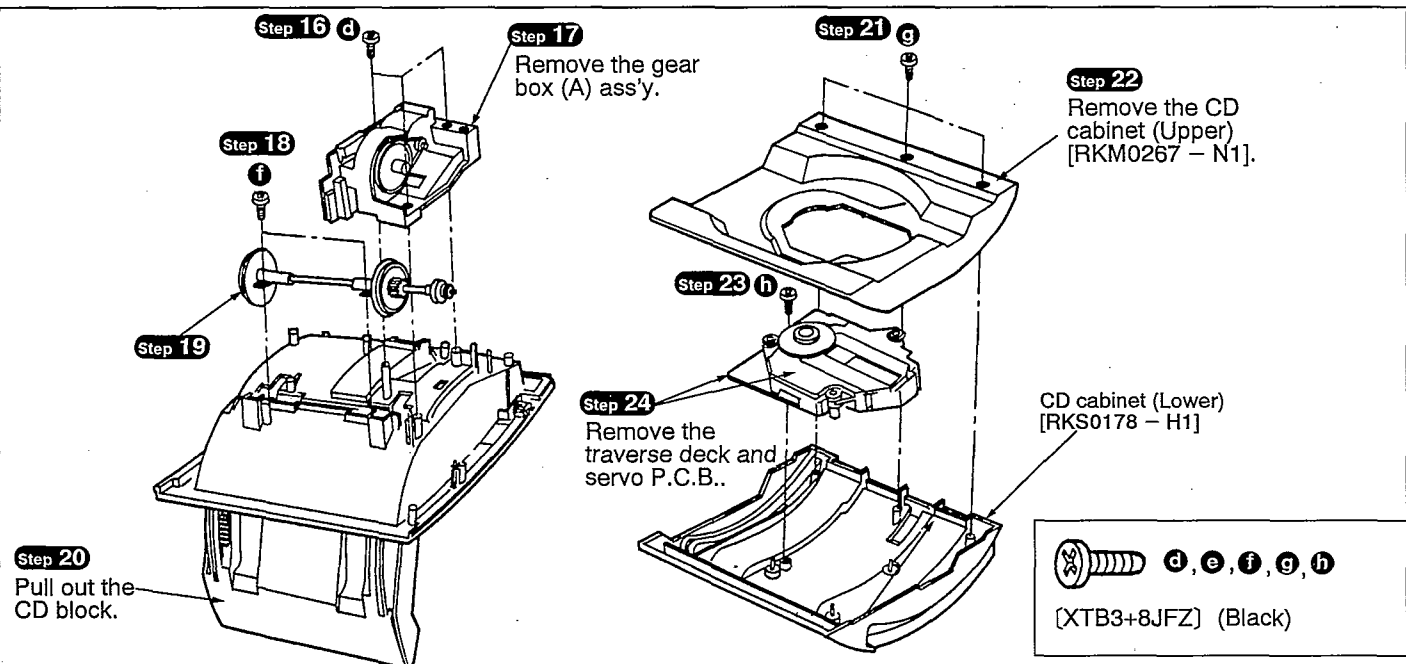

**Installation of CD door ass'y and CD**

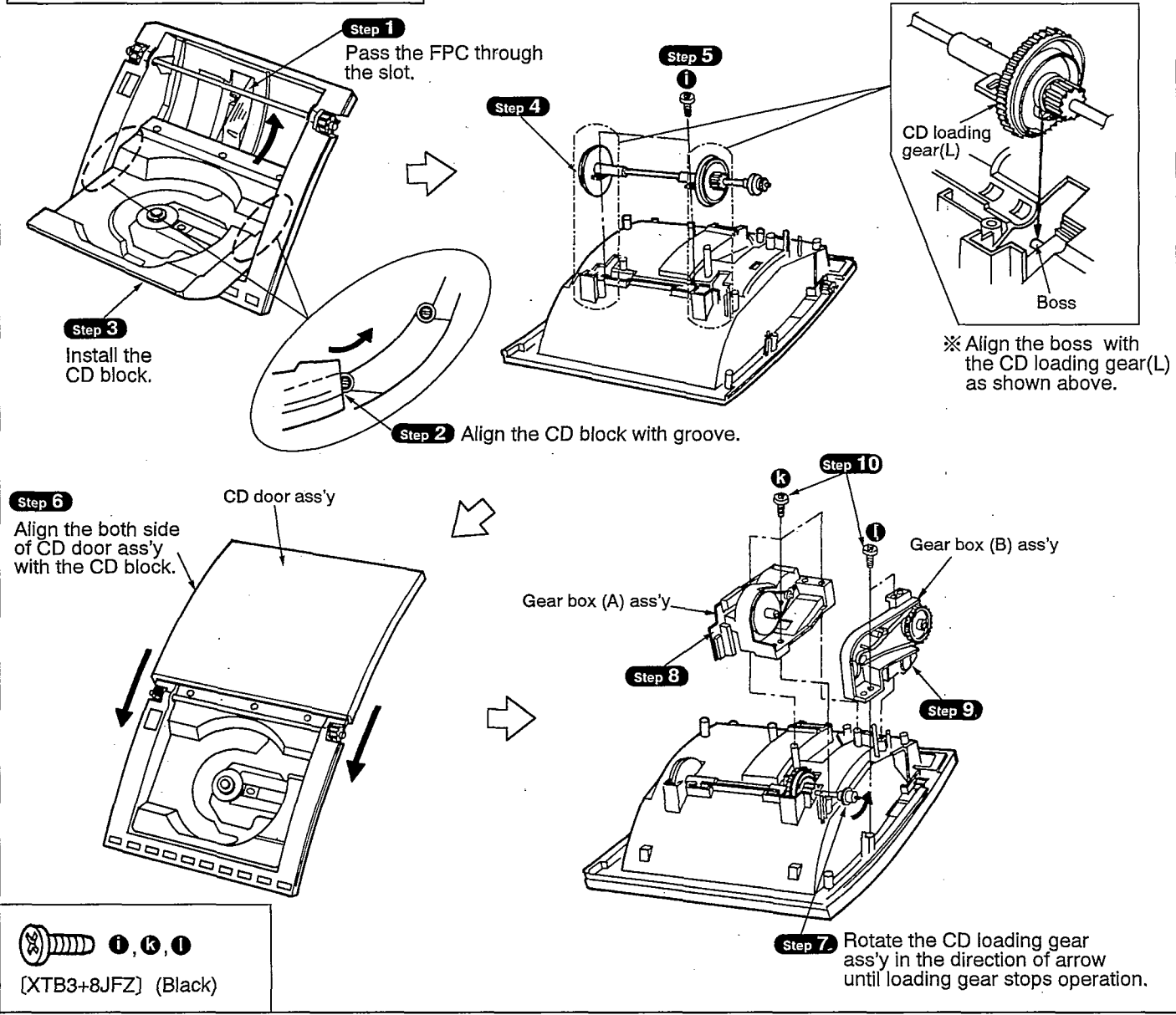

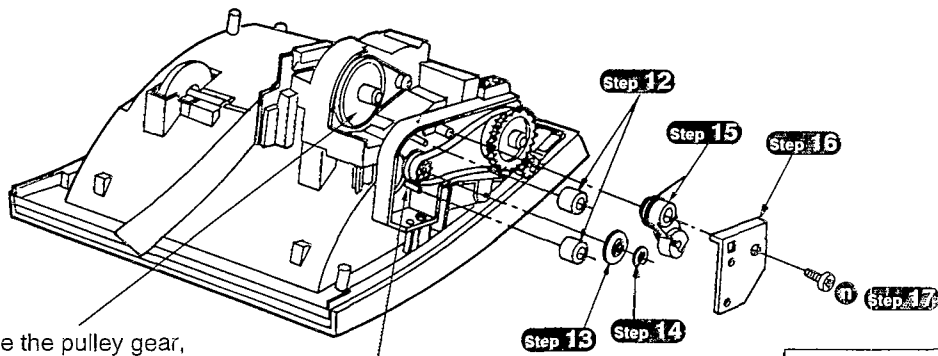

※ After installation, rotate the pulley gear, and then make sure that the CD door ass'y and CD block will be operated.

**Step 11**  
Install the timing belt on the gear(A).



[XTB3+8JFZ] (Black)

#### 4. Replacement for the head block ass'y and pinch arm unit

•Follow the item 1 ( **Step 1** ~ **Step 5** ) in checking procedures for each P.C.B. on page 38.

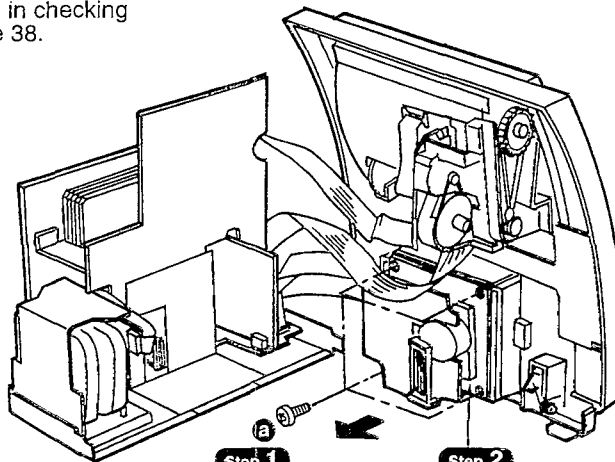

**Step 1**

**Step 2**

Remove the mechanism unit.

**Step 5**  
Release the claws.

**Step 9**  
Remove the cassette holder from the boss.

Boss

**Step 7**  
Remove the rivet.

**Step 8**  
Push the drive rack.

**Step 6**

**Step 3**  
Unsolder the terminals.

**NOTE**

Handle the connector with care so that the shape of terminal is different from others.

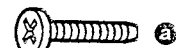
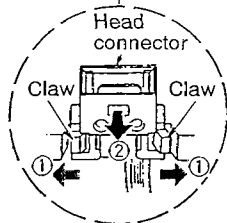
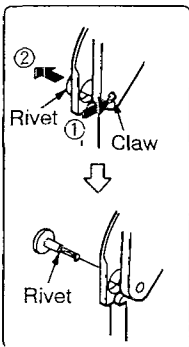

[XTB3+12JFZ] (Black)



[XTW2+6S]

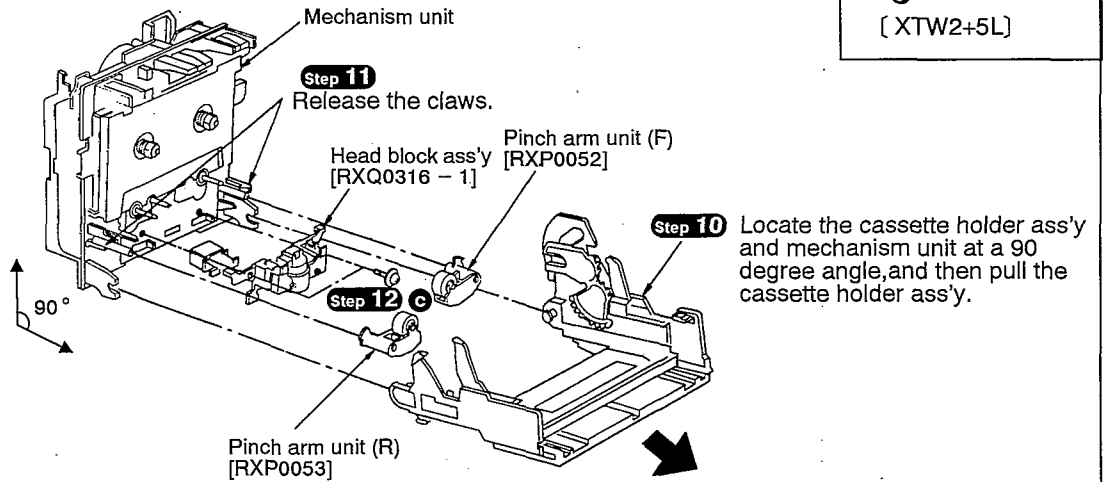
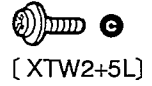

**Installation of the cassette holder ass'y after replacement**

**Step 1** Locate the cassette holder ass'y and mechanism unit at a 90 degree angle, and then install the cassette holder.

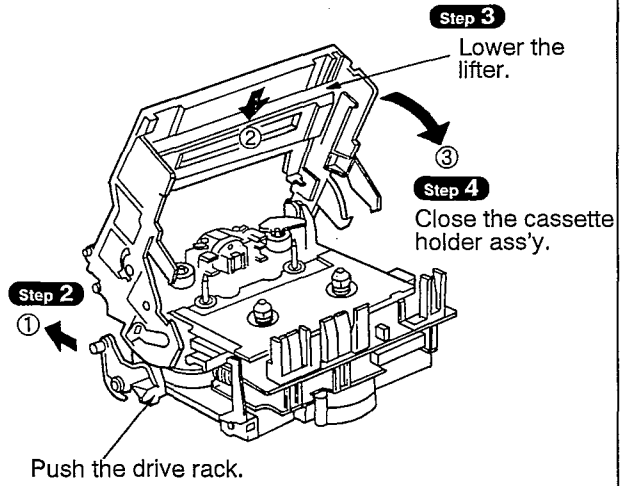
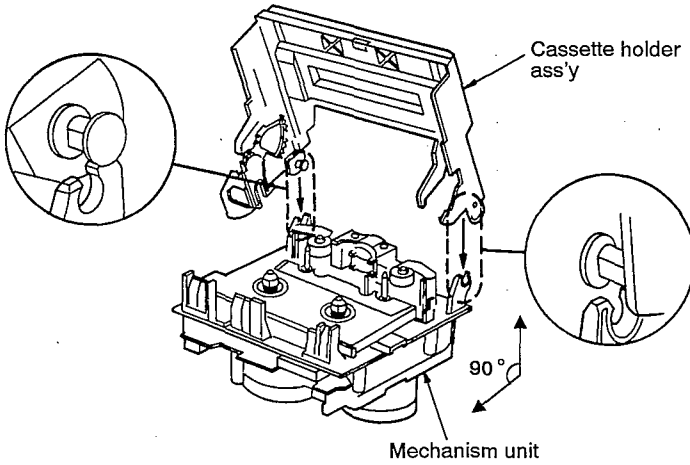

**5. Replacement for the belt, reel motor, capstan motor**

• Follow the **Step 1 ~ Step 9** in item 4 of main component replacement procedures on page 45.

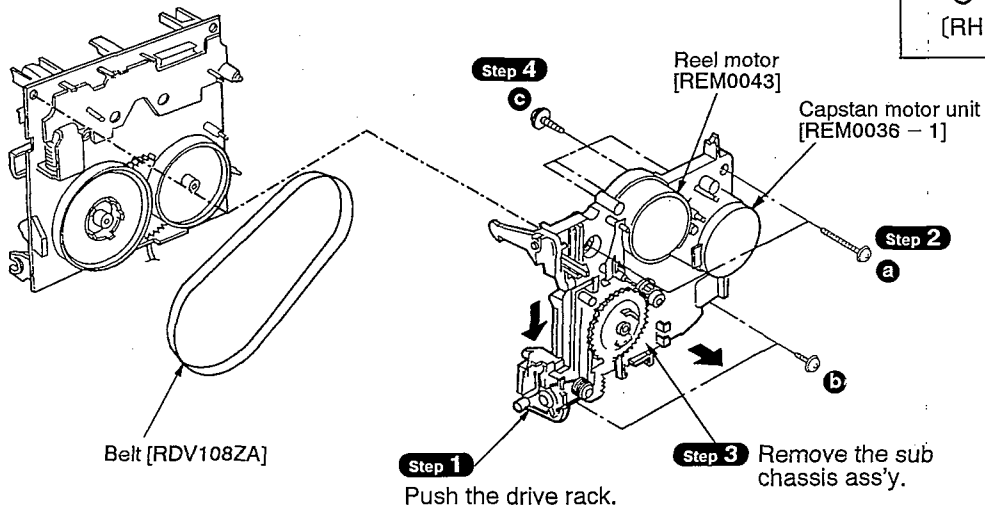
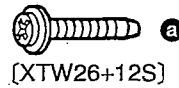

**Installation of the sub chassis ass'y after replacement**

**Step 1** Place the idler lever unit in the center as shown below.

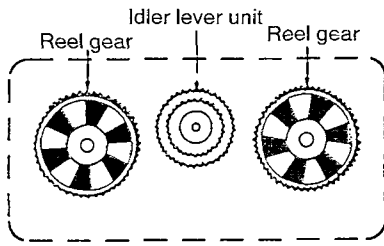

**Step 2** Temporarily secure the belt as shown below.

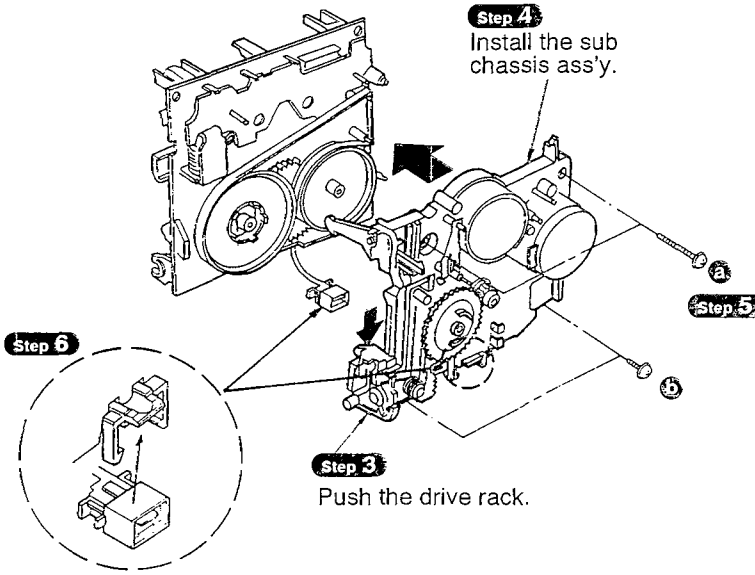
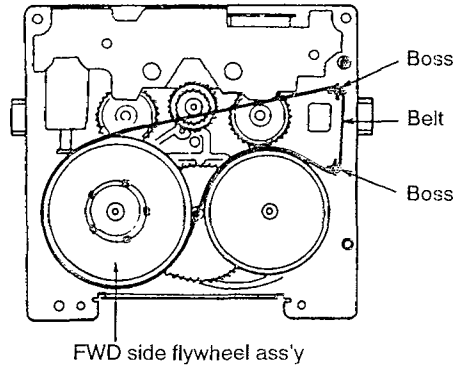

**Step 7** Secure the belt with the capstan motor pulley.

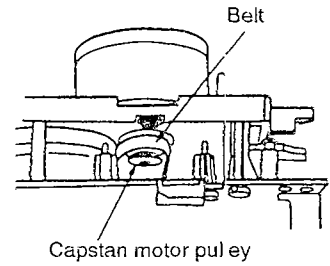
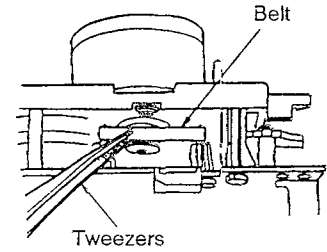

[XTW26+12S]



[XTW26+6L]

**3. Replacement for the solenoid and the parts mounted on mechanism P.C.B.**

• Follow the **Step 1** ~ **Step 3** in item 5 of main component procedures on page 46.

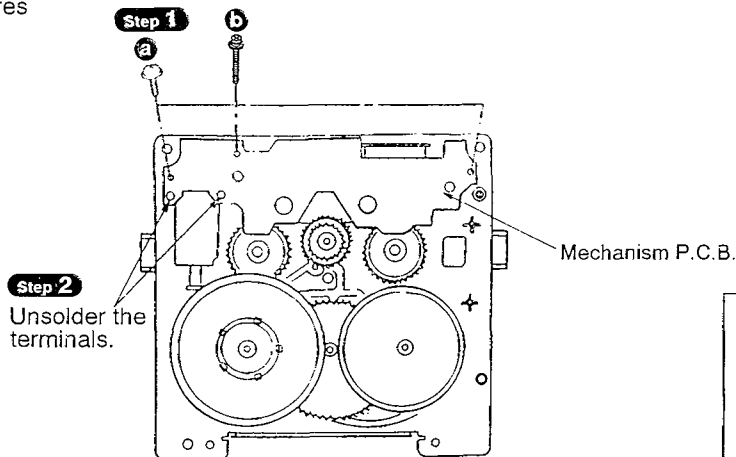

[XTW2+6S]



[XYC2+JF16]

**Step 3**  
Release the claws.

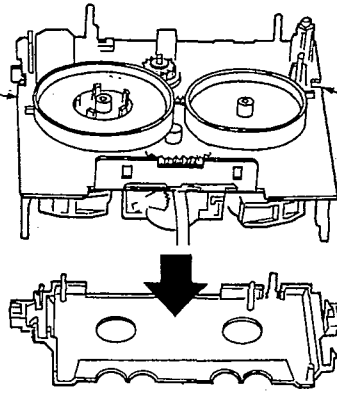
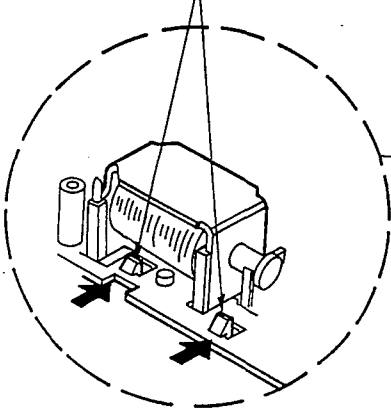

Release the claws.

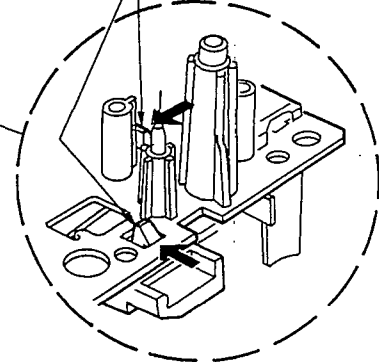

**Step 4**

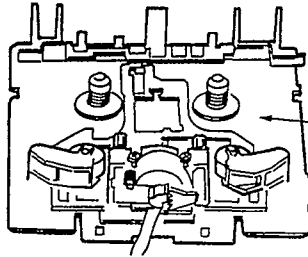

**Step 5**  
Release the claws.

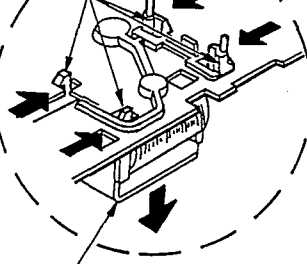

Solenoid  
[RJS0003]

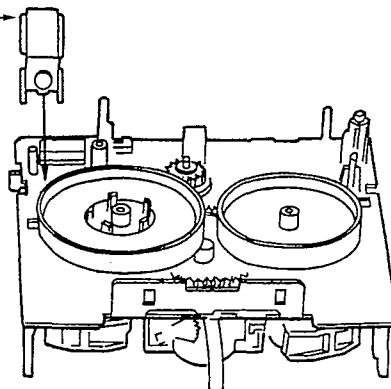
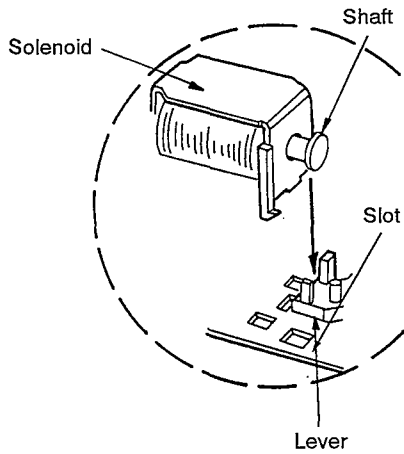

**NOTE**

**Notice of installing the solenoid**  
• The shaft of solenoid should be aligned with the slot of lever.



## MEASUREMENTS AND ADJUSTMENTS

### • Cassette deck section

#### • Measurement Condition

- Dolby NR switch; Off
- Make sure heads are clean

#### • Measuring instrument

- EVM (Electronic Voltmeter)
- Oscilloscope

#### • Test tape

- QZZCWAT; Tape speed adjustment (3kHz, -10dB).
- QZZCFM; Head azimuth adjustment (8kHz, -20dB).
  - Playback frequency response (315Hz, 12.5kHz, 10kHz, 8kHz, 4kHz, 1kHz, 250Hz, 125Hz, 63Hz, -20dB).
  - Playback gain adjustment (315Hz, 0dB).

- Make sure capstan and pressure roller are clean
- Judgeable room temperature  $20 \pm 5^\circ\text{C}$  ( $68 \pm 9^\circ\text{F}$ )

- Digital frequency counter

- QZZCRA; Overall frequency response, Overall gain adjustment Normal reference blank tape.

- QZZCRX; CrO<sub>2</sub> reference blank tape.
- QZZCRZ; Metal reference blank tape.

## HEAD AZIMUTH ADJUSTMENT

### Caution:

- Please replace both azimuth adjustment screws (RHD17015) used for to new ones simultaneously when readjusting the head azimuth. (Shown in Fig. 2.) Even if you wish to readjust the head azimuth without replacing the screws, a fine adjustment can not be done because of the screw-locking bond adhered to the azimuth screw.
- Please remove the screw-locking bond left on the head base when replacing the azimuth screw.
- If you wish to readjust the head azimuth, be sure to adjust with adhering the cassette tape closely to the mechanism by pushing the center of cassette tape with your finger. (Shown in Fig. 3.)

1. Playback the azimuth adjustment portion (8kHz, -20dB) of the test tape (QZZCFM) in the forward play mode. Vary the azimuth adjusting screw until the output of the R-CH are maximized.
2. Perform the same adjustment in the reverse play mode.
3. After the adjustment, apply screwlock to the azimuth adjusting screw.

### CHECK THE LEVEL (FORWARD AND REVERSE)

4. Playback the gain adjusted portion (315Hz, 0dB) of the test tape (QZZCFM) in the forward play mode. Perform the same adjustment in the reverse play mode. Assure that the levels are within 1dB of each other.
5. After adjustment, adhere the screw-locking bond to azimuth screw.

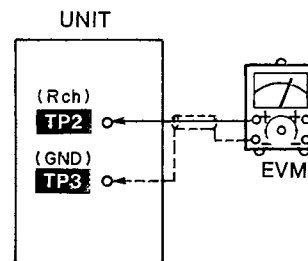

Fig. 1



Fig. 2

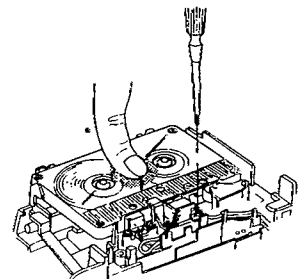

Fig. 3

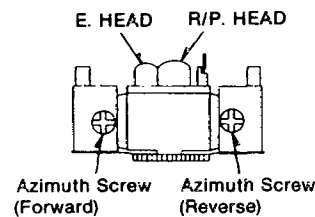

Fig. 4

## TAPE SPEED ADJUSTMENT

(Standard Value:  $3000 \pm 45\text{Hz}$ )

1. Playback the middle portion of the test tape (QZZCWAT).
2. Adjust VR603 so that the output is within the adjustment target.

Adjustment target:  $3000\text{Hz} \pm 20\text{Hz}$

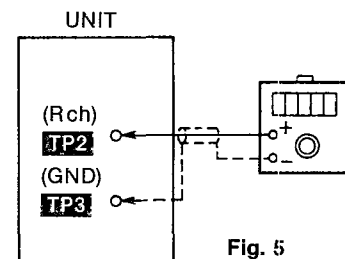

Fig. 5

### PLAYBACK GAIN ADJUSTMENT

1. Playback the gain adjusted portion (315Hz, 0dB) of the test tape (QZZCFM).
2. Adjust VR601 (L-CH) [[VR602 (R-CH)]] so that the output is within the adjustment target.

Standard value:  $285\text{mV} \pm 1.0\text{dB}$

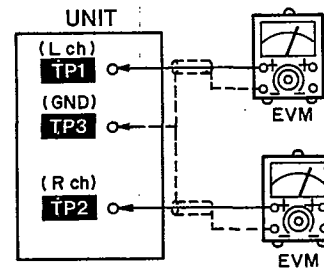

Fig. 6

### PLAYBACK FREQUENCY RESPONSE

1. Playback the frequency response portion (315Hz, 12.5kHz~63Hz, -20dB) of the test tape (QZZCFM).
2. Assure that the frequency response is within the range shown in Fig. 8 for both L-CH and R-CH.

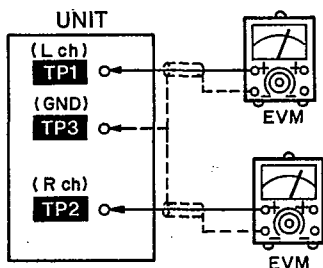

Fig. 7

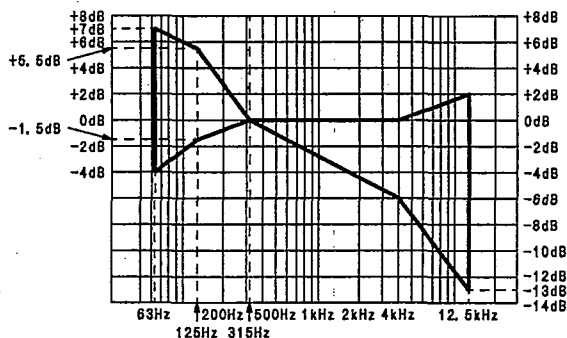

Fig. 8

### ERASE CURRENT CONFIRMATION

1. Insert the Metal blank test tape (QZZCRZ) and set the unit to the Record Pause mode.
2. Assure so that the output between TP4 (+) and TP5 (-) is within the adjustment target.

Standard value:  $33\text{mV} \pm 3\text{mV}$

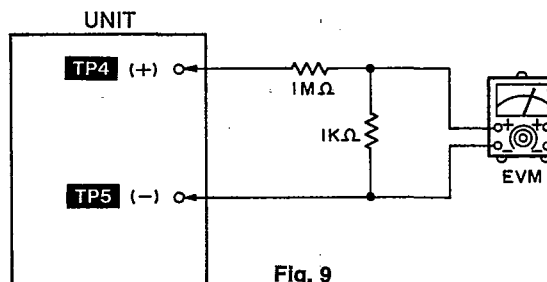

Fig. 9

### • Adjustment points

<Cassette deck section>

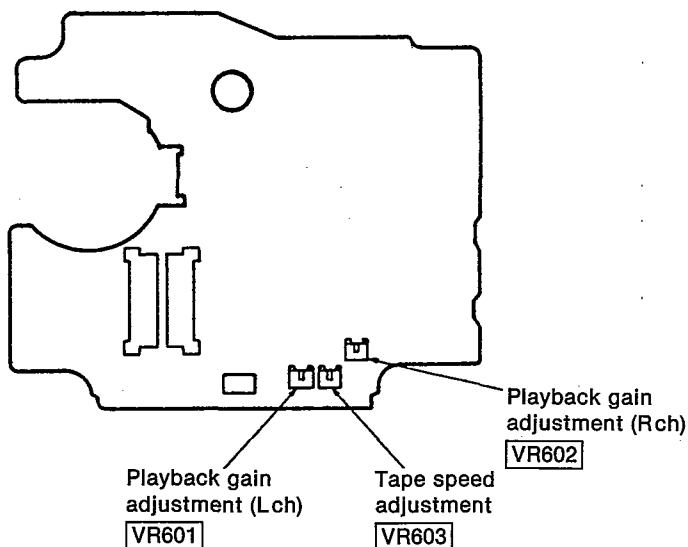

Fig. 10

### • Compact disc player section

**Warning:** This product uses a laser diode. Refer to caution statements on page 3.

**ACHTUNG:** • Die Lasereinheit nicht zerlegen.  
• Die Lasereinheit darf nur gegen eine vom Hersteller spezifizierte Einheit ausgetauscht werden.

### Measuring Instruments and Special Tools

- \* Test discs
  1. SZZP1054C (Playability test disc).
  2. SZZP1056C (Uneven test disc).
- \* Musical program disc (ordinary).
- \* Dual-beam oscilloscope with bandwidth of 30MHz or better (with EXT. trigger and 1:1 probe).
- \* SZZP1101C (Allen wrench).
- \* RZZ0L01 (Lock paint).

### (1) MECHANICAL ADJUSTMENT

- When the traverse deck is replaced, making adjustments is not necessary. (The traverse deck ass'y is already adjusted.)
  - Make adjustments to improve playability if the traverse deck has not been replaced.
  - Refer to the "Checking for the servo P.C.B." before adjustment on page 40.
1. Connect the oscilloscope's CH. 1 probe across **TP101** (RF) (+) and **TP102** (VREF) (-) on the servo P.C.B. (Refer to Fig. 12 on page 52.)  
**Oscilloscope setting:** VOLT ..... 100mV  
 SWEEP ..... 0.5 $\mu$ s.  
 Input coupling ..... AC
  2. Switch the player power **ON**, and play track 19 on the test disc (SZZP1056C).
  3. Alternately adjust the HEX screws with the 2.0mm allen wrench (SZZP1101C) until the vertical fluctuation of RF signal is minimized and the eye pattern is most stretched.  
(Refer to Fig. 13 on page 52.)
  4. After completing the adjustment, lock the HEX screws with lock paint (RZZ0L01).

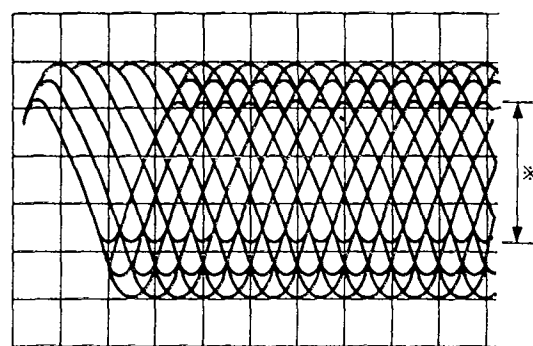

\* Most stretched eye pattern.

Fig. 11

### (2) CHECK OF PLAY OPERATION AFTER ADJUSTMENT

#### \* Checking Skip Search

1. Play an ordinary musical program disc.
2. Press the skip button to check for normal skip search operation (in both the forward and reverse directions).

#### \* Checking Manual Search

1. Play an ordinary musical program disc.
2. Press the manual search button to check for smooth manual search operations at either low or high speed (in both the forward and reverse directions).

#### \* Checking Playability

1. Play the 0.7 mm black dot and the 0.7 mm wedge on the test disc (SZZP1054C) and verify that no sound skip or noise occurs.
2. Play the middle tracks of the uneven test disc (SZZP1056C) and verify that no sound skip or noise occurs.

### • Adjustment points

<Compact disc player section>

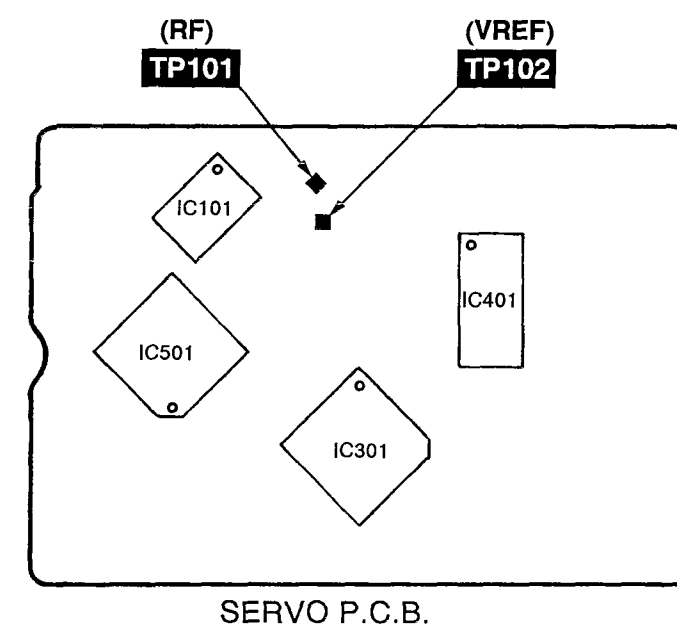

Fig. 12

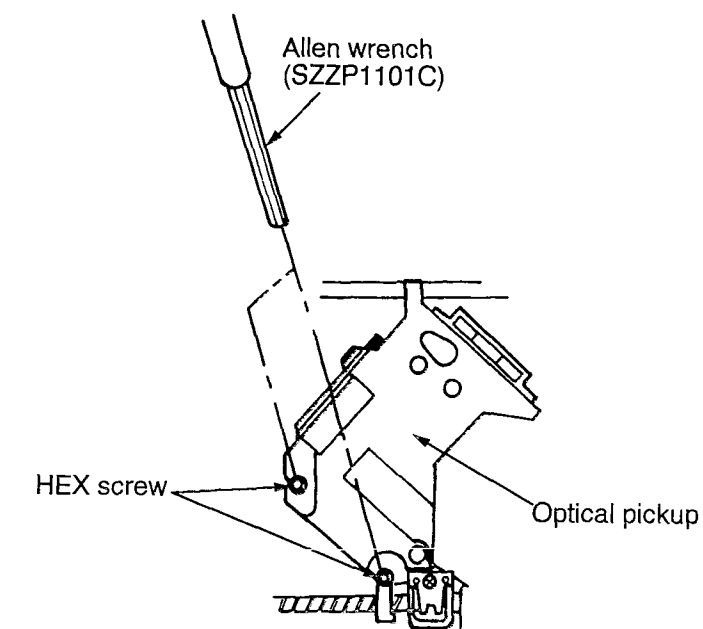
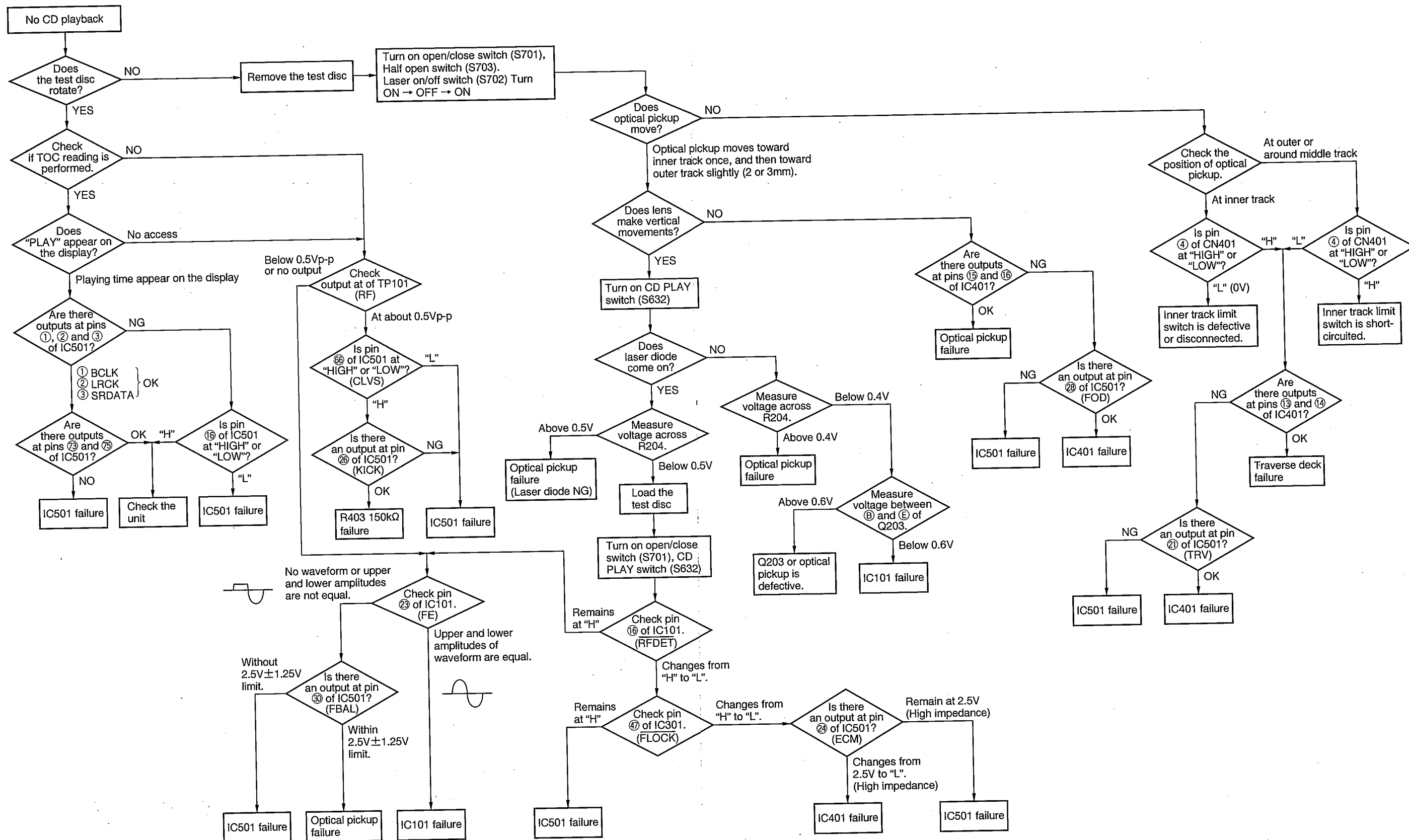

Fig. 13

### ■ NEW DIGITAL SERVO CIRCUIT

For this model we have adopted new IC to substantialize "no adjustment required for electric section". (As for conventional models, the "Best Eye Adjustment" has been required.)

■ TROUBLESHOOTING GUIDE



## ■ TERMINAL FUNCTION OF IC'S

• IC501 (MN662740RE): Servo processor/digital signal processor/digital filter/D/A converter

Pin No.	Mark	I/O Division	Function
1	BCLK	O	Serial bit clock output
2	LRCK	O	L/R discriminating signal output
3	SRDATA	O	Serial data signal output
4	DV <sub>DD1</sub>	I	Power supply (digital circuit) terminal
5	DV <sub>SS1</sub>	—	GND (digital circuit) terminal
6	TX	O	Digital audio interface signal (Not used, open)
7	MCLK	I	Command clock signal
8	MDATA	I	Command data signal
9	MLD	I	Command load signal ("L": LOAD)
10	SENSE	O	Sense signal (OFT, FESL, NACEND, NAJEND, POSAD, SFG) (Not used, open)
11	FLOCK	O	Optical servo condition (focus) ("L": lead-in) (Not used, open)
12	TLOCK	O	Optical servo condition (tracking) ("L": lead-in) (Not used, open)
13	BLKCK	O	Sub-code block clock (f=75Hz) (Not used, open)
14	SQCK	I	Sub-code Q register clock
15	SUBQ	O	Sub-code Q data
16	DMUTE	I	Muting input ("H": MUTE) (Not used, connected to GND)
17	STAT	O	Status signal (CRC, CUE, CLVS, TTSTOP, FCLV, SQCK)
18	RESET	I	Reset signal ("L": reset)
19	SMCK	O	System clock (f=4.2336MHz)
20	PMCK	O	Frequency division clock signal ( $f = \frac{1}{1.92} \times ck = 88.2\text{kHz}$ )
21	TRV	O	Traverse servo control

Pin No.	Mark	I/O Division	Function
22	TVD	O	Traverse drive signal
23	PC	O	Turntable motor drive signal ("L": ON)
24	ECM	O	Turntable motor drive signal (Forced mode)
25	ECS	O	Turntable motor drive signal (Servo error signal)
26	KICK	O	Kick pulse output
27	TRD	O	Tracking drive signal output
28	FOD	O	Focus drive signal output
29	VREF	I	D/A drive output (TVD, ECS, TRD, FOD, FBAL, TBAL) normal voltage input terminal
30	FBAL	O	Focus balance adj. output (Not used, open)
31	TBAL	O	Tracking balance adj. output
32	FE	I	Focus error signal (analog input)
33	TE	I	Tracking error signal (analog input)
34	RFENV	I	RF envelope signal
35	VDET	I	Oscillation det. signal ("H": det.)
36	OFTR	I	Off track signal ("H": Off track)
37	TRCRS	I	Track cross signal input
38	RFDET	I	RF detection signal ("L": detection)
39	BDO	I	Dropout detection signal ("H": dropout)
40	LDON	O	Laser power control ("H": ON)
41	TES	O	Tracking error shunt output ("H": dropout)
42	PLAY	O	Play signal ("H": play)

Pin No.	Mark	I/O Division	Function
43	WVEL	O	Double velocity status signal ("H": double) (Not used, open)
44	ARF	I	RF signal input
45	IREF	I	Reference current input
46	DRF	I	DSL bias terminal (Not used, connected to GND)
47	DSLFL	I/O	DSL loop filter terminal
48	PLLFL	I/O	PLL loop filter terminal
49	VCOF	I	VCO loop filter terminal (Not used, connected to AV <sub>DD2</sub> )
50	AV <sub>DD2</sub>	I	Power supply (analog circuit) terminal (2)
51	AV <sub>SS2</sub>	—	GND (analog circuit) terminal
52	EFM	—	EFM signal output (Not used, open)
53	PCK	—	PLL extract clock (f=4.3218MHz) (Not used, open)
54	PDO	—	Tracking servo OFF signal (Not used, open)
55	SUBC	—	Sub-code serial output data (Not used, open)
56	SBCK	—	Sub-code serial input clock (Not used, open)
57	V <sub>SS</sub>	—	GND terminal
58	X1	I	Crystal oscillator terminal (f=16.9344MHz)
59	X2	O	
60	V <sub>DD</sub>	I	Power supply terminal
61	BYTCK	O	Bite clock output terminal (Not used, open)
62	CLDCK	O	Sub-code frame clock signal (f CLDCK=7.35kHz: Normal) (Not used, open)
63	FCLK	O	Crystal frame clock (Not used, open)

Pin No.	Mark	I/O Division	Function
64	IPFLAG	O	Interpolation flag terminal (Not used, open)
65	FLAGO	O	Flag terminal (Not used, open)
66	CLVS	O	Turntable servo phase synchro signal ("H": CLV, "L": Rough servo) (Not used, open)
67	CRC	O	Sub-code CRC check terminal ("H": OK, "L": NG) (Not used, open)
68	DEMPHA	O	De-emphasis ON signal ("H": ON) (Not used, open)
69	RESY	O	Re-synchronizing signal of frame sync. (Not used, open)
70	/RST2	I	Reset terminal after "MASH" circuit ("L": Reset)
71	TEST	I	Test terminal (Normal: "H")
72	AV <sub>DD1</sub>	I	Power supply (analog circuit) terminal (1)
73	OUTL	O	Lch audio signal
74	AV <sub>SS1</sub>	—	GND (analog circuit) terminal (1)
75	OUTR	O	Rch audio signal
76	RSEL	I	Polarity direction control terminal of RF signal (Not used, connected to power supply)
77	CSEL	I	Frequency control terminal of crystal oscillator (Not used, connected to GND)
78	SRSEL	I	Serial data signal input
79	MSEL	I	"SMCK" terminal frequency select (Not used, open) ("L": SMCK=4.2336MHz) ("H": SMCK=8.4672MHz)
80	SSEL	I	"SUBQ" terminal mode select ("H": Q code buffer)

## • IC101 (AN8832SBE1): Servo amp

Pin No.	Mark	I/O Division	Function
1	PDAD	I	Photo detector current input
2	PDA	I	Photo detector current input
3	LPD	I	Non-inverting laser power input
4	LD	O	Laser power auto control output
5	AMPI	I	RF signal input Not used, connected to V <sub>CC</sub>
6	V <sub>CC</sub>	I	Power supply terminal
7	RFIN	I	RF signal input
8	CAGC	I	AGC detecting capacitor terminal
9	ARF	O	RF signal output
10	CEA	I	HPF-amp. terminal
11	GND	—	Ground terminal
12	LDON	I	Laser ON/OFF control input
13	PLAY	I	Play control terminal
14	WVEL	—	WVEL control terminal Not used, open

Pin No.	Mark	I/O Division	Function
15	BDO	O	Dropout detection output
16	RFDET	O	NRDET signal output
17	TRCRS	O	CROSS signal output
18	OFTR	O	OFTR signal output
19	VDET	O	VDET signal output
20	RFENV	O	Envelope signal output
21	TEBPF	I	Shock detection signal input
22	TE	O	Tracking error signal output
23	FE	O	Focus error signal output
24	TBAL	I	Tracking balance signal input
25	FBAL	I	Focus balance signal input
26	VREF	O	Reference voltage output
27	PDB	I	Photo detector current input
28	PDBD	I	Photo detector current input

## • IC301 (LC66306A4D87): CD System control

Pin No.	Mark	I/O Division	Function
1	RESTSW	I	Rest detect input terminal
2	SERVO RST	O	Servo reset output
3	STAT	I	Processing status (CRC, CUE, CLVS, FCLV, TTSTOP) input terminal
4	SUBQ	I	Sub-cord (Q data) output terminal
5	DMUTE	O	Muting output terminal ("H": MUTE)
6	NC	—	No connection
7	SQCK	O	Sub-cord Q resistor external clock signal terminal
8	BLKCK	I	Sub-code block clock signal input (f=BLKCK=75Hz, in normal play mode)
9	NU	—	Not used, connected to power supply
10	GMUTE	—	Not used, open

Pin No.	Mark	I/O Division	Function
11	NU	—	Not used, open
12	NU	—	Not used, connected to power supply
13	MLD	O	Microcomputer command load signal output terminal
14	MDATA	O	Microcomputer command data signal output terminal
15	TEST	I	CPU test terminal
16	VSS	—	GND terminal
17	OSC1	I	System clock oscillator external mount terminal
18 • 19	NC	—	No connection
20	OSC2	O	Not used, open
21	/RESET	I	Reset signal input terminal

Pin No.	Mark	I/O Division	Function
22	MCLK	O	Microcomputer command clock signal output terminal
23 • 24	NU	—	Not used, open
25	NU	—	Not used, open
26	CS	I	Chip select input terminal
27	REQ	—	Not used, connected to power supply
28	DT	I	Serial data signal input
29	DT	O	Serial data signal output
30	NC	—	No connection
31	CLK	O	Serial clock signal output
32	VCS	—	Not used, open
33	VCLK	O	ASP control clock signal output terminal
34	VDATA I/O	—	Not used, open

Pin No.	Mark	I/O Division	Function
35 • 37	NU	—	Not used, connected to GND
38	VREQ	I	Request signal input terminal
39	VDD	I	Power supply terminal
40	CLOSESW	I	Disk close detect terminal
41	OPENSW	I	Disk open detect terminal
42 • 43	NC	—	No connection
44	/CLOSE	—	Not used, open
45	/OPEN	—	Not used, open
46	SENSE	I	Sense signal input terminal (OFT, FSEL, NACEND, NAJEND, POSAD, SFG)
47	/FLOCK	I	Optical servo condition (focus) ("L": Lead-in)
48	/TLOCK	I	Optical servo condition (tracking) ("L": Lead-in)

• IC401 (BA6890FPE1): Motor drive

Pin No.	Mark	I/O Division	Function
1	BIAS	I	Bias input terminal
2	IN1	I	CH1 input terminal
3	MUTE1	I	CH1 mute terminal
4	IN2	I	CH2 input terminal
5	MUTE2	I	CH2 mute terminal
6	NC	—	Test terminal
7	PREGND	—	Preamp GND terminal
8 • 9	PWGND	—	Preamp GND terminal
10	VCCPOW	I	Power supply terminal
11	OUT2-	O	CH2- output terminal
12	OUT2+	O	CH2+ output terminal
13	OUT1-	O	CH1- output terminal
14	OUT1+	O	CH1+ output terminal

Pin No.	Mark	I/O Division	Function
15	OUT4+	O	CH4+ output terminal
16	OUT4-	O	CH4- output terminal
17	OUT3+	O	CH3+ output terminal
18	OUT3-	O	CH3- output terminal
19	VCCPOW	I	Power supply terminal
20 • 21	PWGND	—	Power amp GND terminal
22	PREGND	—	Preamp GND terminal
23	NC	—	No connection
24	MUTE3	I	CH3 mute terminal
25	IN3	I	CH3 input terminal
26	MUTE4	I	CH4 mute terminal
27	IN4	I	CH4 input terminal
28	VCCPRE	I	Preamp power supply terminal



• IC201 (MSM6650GSV1K): Voice composition

Pin No.	Mark	I/O Division	Function
1 • 2	NC	—	No connection
3	/BUSY	O	Voice emission output terminal ("L": Voice emission, "H": Power on)
4	NAR	O	Address latch I0~I6 empty status detect signal ("H": empty)
5	AOUT	O	Built-in LPF voice output terminal
6	AGND	—	GND (analog circuit) terminal
7	DGND	—	GND (digital circuit) terminal
8	AVDD	—	Power supply (analog circuit) terminal
9	DVDD	—	Power supply (digital circuit) terminal
10	XT	I	Ceramic oscillator input terminal
11	/XT	O	Ceramic oscillator output terminal
12	MCK	O	Main clock output terminal
13	/CMD	I	Command input, option control terminal (ST="L" at /CMD="L" →option input)
14	/ST	I	Strobe signal input
15	/TEST1	I	Test terminal
16	CPU	I	Usually used at "H" (connected to power supply)

Pin No.	Mark	I/O Division	Function
17	SIRIAL	I	Parallel input interface terminal at "L"
18	/1BUSY	—	Not used, open
19	NC	—	No connection
20	/STBY	—	Not used, open
21 } 27	I0 } I6	I	Command and user designated phrase input (during parallel input interface)
28	/CH	I	Channel control signal ("H"=1 ch, "L"=2 ch)
29	/RST	I	Reset signal input terminal ("L": reset)
30	/CE	O	External memory read control timing terminal (/RCS="L": output)
31	/RCS	I	RA22~RA0 and /CE output at "L" (connected to GND)
32	D0	I	External memory data input terminal (/RCS="L": data input)
33	NC	—	No connection
34 } 40	D1 } D7	I	External memory data input terminal (/RCS="L": data input)
41 } 63	RA0 } RA22	O	External memory address terminals (/RCS="L": output)
64	/TEST2	I	Test terminal

• IC202 (LH5347N4): 4M ROM

Pin No.	Mark	I/O Division	Function
1	OE1/OE1 /DC	—	Not used, open
2 } 12	A16 } A0	I	Address input terminal
13 } 15	D0 } D2	O	Data output terminal
16	VSS	—	GND terminal
17 } 21	D3 } D7	O	Data output terminal

Pin No.	Mark	I/O Division	Function
22	/CE	I	Chip enable terminal
23	A10	I	Address input terminal
24	/OE	I	Output enable terminal
25 } 31	A11 } A18	I	Address input terminal
32	VCC	I	Power supply (+5V) terminal

## • IC601 (UPD78044A077): System control &amp; FL drive

Pin No.	Mark	I/O Division	Function
1 } 7	DGT6 } DGT0	O	FL digit signal output terminal
8	VDD	I	Power supply terminal
9	P-CONT	O	Power supply control signal output terminal
10	MUTE	O	Muting control signal output terminal
11	CD-RST	O	Reset signal output (CD player)
12	CD-CS	O	Chip select signal output (CD player)
13	CD-REQ	O	Request signal output (CD player)
14	CD-CLK	O	Clock signal output (CD player)
15	CD-SO	O	Serial data control output terminal (CD player)
16	CD-SI	I	Serial data input (CD player)
17	/RESET	I	Reset signal input terminal
18	CD-SW1	I	Disk holder open/close detect terminal ("L": CLOSE, "H": OPEN)
19	CD-SW0	I	Disk holder half detect terminal ("L": CLOSE, "H": HALF OPEN)
20	AVSS	—	GND (analog circuit) terminal
21	STROBE	I	Strobe signal input terminal
22	CR-TIM	I/O	CR-Timer detect terminal
23	AD-SW2	I	AD converter input (Cassette mechanism switch reel pulse input)
24	AD-SW1	I	AD converter input (Cassette mechanism switch and TPS detection)
25	AD-SW0	I	AD converter (Cassette mechanism switch detection)
26 } 28	KEY2 } KEY0	I	Key switch detect terminal
29	AVDD	I	Power supply (analog circuit) terminal
30	AVREF	I	Reference voltage input terminal
31	XT1	—	Not used, open
32	XT2	—	
33	VSS	—	GND terminal
34	X1	I	Crystal oscillator input/output terminal (f=4 MHz)
35	X2	O	
36	VR-LAT	O	ASP control signal output terminal
37	BUZ	O	Buzzer control output terminal

Pin No.	Mark	I/O Division	Function
38	VR-DATA/ POL	O	Serial data output
39	VR-CLK/ MONIT	O	Serial clock output
40	DECK- DATA	O	Deck mechanism control data output
41	DEK-LAT	O	Deck mechanism control data latch output
42	DEK-CLK	O	Deck mechanism control clock output
43	TU-CE	O	Tuner chip enable output
44	TUN-DI	O	Tuner control data output
45	TUN-CLK	O	Tuner control clock output
46	HALT	I	Power down detect terminal
47	REMO	I	Remote control data signal input terminal
48	VPP	—	GND terminal
49	TUN-DO	I	Tuner reception status input
50	SD	I	Reception detect terminal
51	STEREO	I	Stereo status detect terminal ("L": STEREO)
52	VDD	I	Power supply terminal
53	LEDCLK	O	LED drive control clock signal
54	LEDDATA	O	LED drive control data signal
55	KCLK	O	Voice composition clock signal
56	KDATA	O	Voice composition data signal
57	KNAR	O	Address latch I0~I6 empty status detect signal ("H": EMPTY)
58 • 59	CS1 • CS0	I	External resistance connection terminal
60 } 64	SEG0 } SEG4	O	FL segment signal output terminal
65 } 70	SEG5 } SEG10	O	FL segment signal output terminal
71	-VP	I	Pull down voltage input
72 } 77	SEG11 } SEG16	O	FL segment signal output terminal
78	NC	—	No connection
79 • 80	DGT8 • DGT7	O	FL digit signal output terminal

# BLOCK DIAGRAM

• CD Player section

SA-LS10

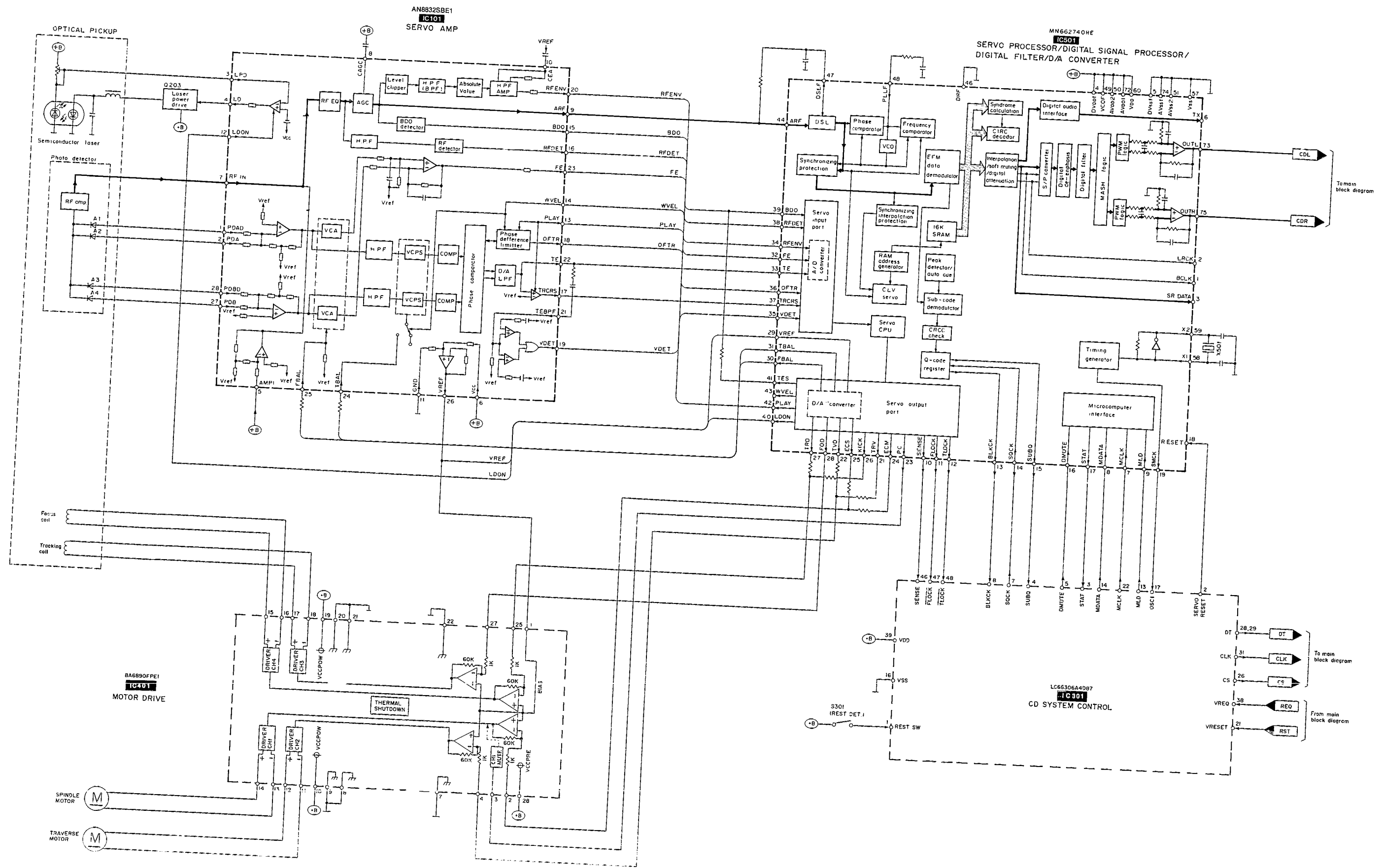

Note:  
→ CD signal

• Tuner/Amplifier/Cassette deck section

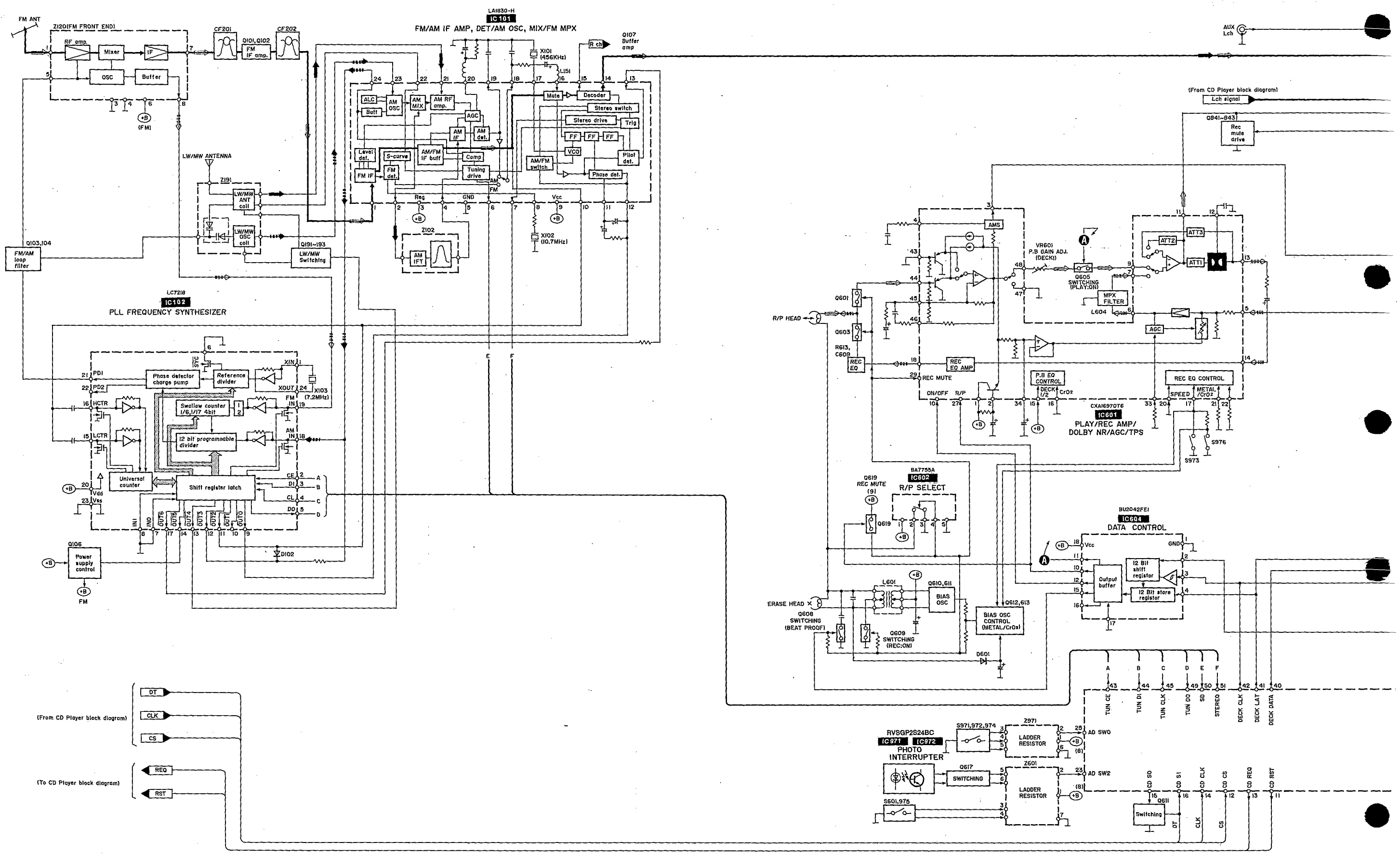

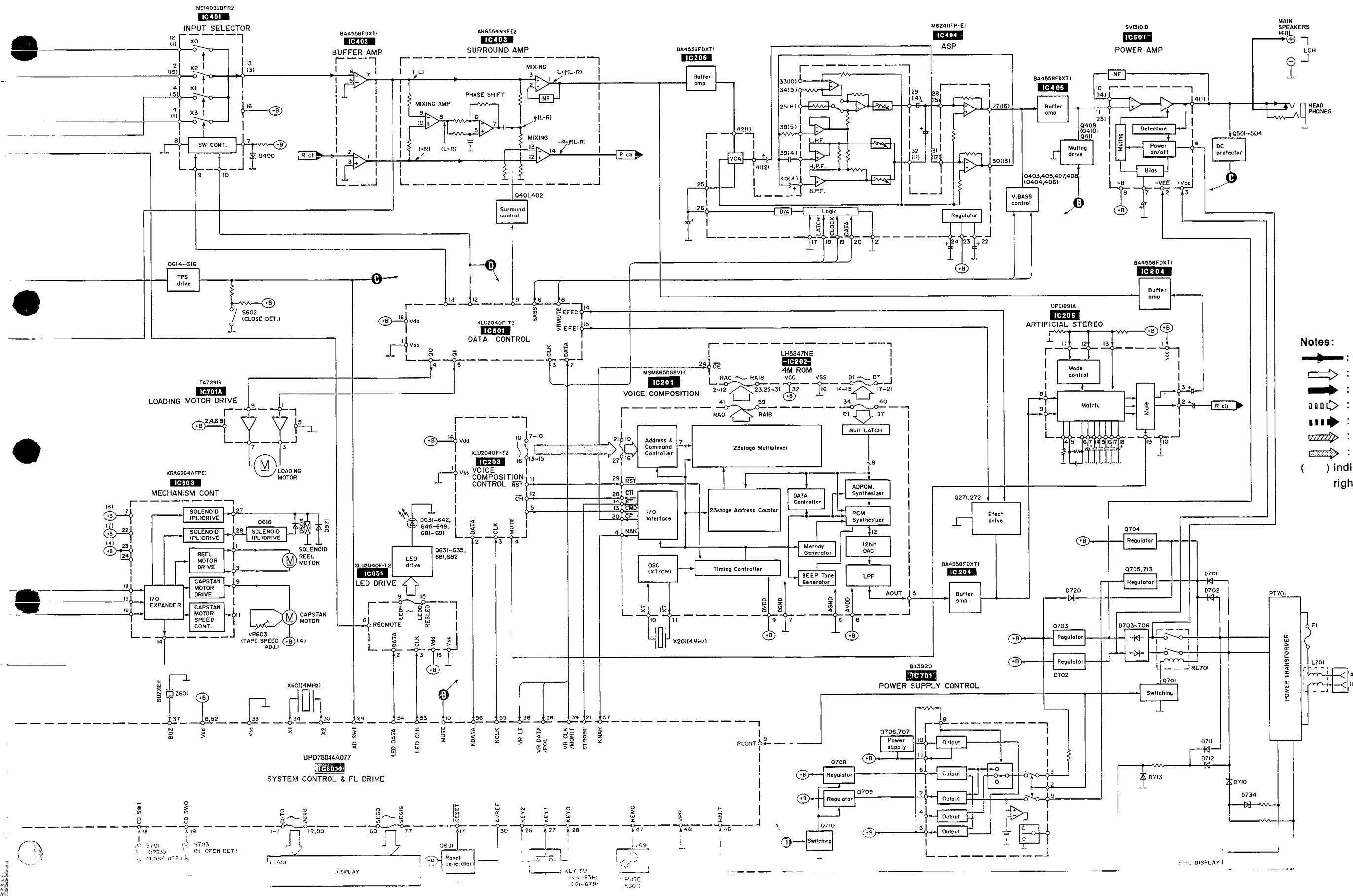

- Notes:**
- : CD signal
  - : FM signal
  - : AM signal
  - ⊞ : AM OSC signal
  - ⊞ : AM OSC signal
  - ▨ : Playback signal
  - ▨ : Recording signal
  - ( ) indicates pin No. of right channel.

# SCHEMATIC DIAGRAM

(Parts list on pages 94~97, 103~107.)

(This schematic diagram may be modified at any time with development of new technology.)

### Notes:

- S301 : Reset det. switch
- S601 : DECK OPEN det. switch.
- S602 : DECK CLOSE det. switch.
- S631 : TAPE/PLAY switch.
- S632 : CD/PLAY (▶) switch.
- S633 : TUNER/BAND switch.
- S634 : STOP (■)/MODE/SET switch.
- S635 : REV (◀◀)/B. SKIP, SEARCH (◀◀/◀◀)/DOWN (▼) switch.
- S636 : FWD (▶▶)/F. SKIP, SEARCH (▶▶/▶▶)/UP (▲) switch.
- S661 : Power "STANDBY Ⓞ /ON" (POWER, STANDBY Ⓞ /ON) switch.
- S662 : Control panel open/close (CONTROL ▲ OPEN/CLOSE) switch.
- S663 : Soundscape effect adjust (EFFECT) switch.
- S664 : Soundscape select (SOUNDSCAPE) switch.
- S665 : Clock/timer set (CLOCK/TIMER) switch.
- S666 : Timer recording/playback (□ REC/PLAY) switch.
- S667 : Volume up (VOLUME +) switch.
- S668 : Volume down (VOLUME -) switch.
- S669 : Front panel open/close (CD ▲ OPEN/CLOSE) switch.
- S670 : Cassette holder open/close (TAPE ▲ OPEN/CLOSE) switch.
- S671 : Sound menu select/beep OFF ON (SOUND MENU) switch.
- S672 : V. bass select (V. BASS) switch.
- S673 : Memory (MEMORY) switch.
- S674 : Dolby noise reduction (DOLBY NR) switch.
- S675 : Tape direction select (DIRECTION) switch.
- S676 : Record (● REC) switch.
- S677 : CD edit-recording (EDIT) switches.
- S678 : Auxiliary input (AUX) switch.
- S701 : Open/Close det. switch
- S702 : Laser ON/OFF switch
- S703 : Half Open det. switch
- S971 : Mode switch.
- S972 : HALF switch.
- S973 : ATS/CrO<sub>2</sub> tape switch.
- S974 : Rewind recorder inhibit switch.
- S975 : Forward recorder inhibit switch.
- S976 : ATS/METAL det. switch.

• The voltage value and waveforms are the reference voltage of this unit measured by DC electronic voltmeter (high impedance) and oscilloscope on the basis of chassis.

Accordingly, there may arise some error in voltage values and waveforms depending upon the internal impedance of the tester or the measuring unit.

<Compact disc player section>

No mark: STOP

( ): Playback (Test disc 1kHz, L+R 0dB)

<Tuner/Amplifier/Cassette deck section>

No mark: TUNER mode (No signal)

< : FM

⌈ : MW

⌋ : TUNER mode

[ : TAPE mode

(( )) : Playback

◀ : Record

◻ : LW

⌋ : AUX mode

### • Signal line

▬ : Positive voltage lines

→ : FM signal

⏏ : FM OSC

→ : Recording signal

▬ : Negative voltage lines

→ : AM (MW/LW) signal

⏏ : AM (MW/LW) OSC

▬ : Playback signal

→ : CD signal

### • Important safety notice:

Components identified by Δ mark have special characteristics important for safety. Furthermore, special parts which have purposes of fire-retardant (resistors), high-quality sound (capacitors), low-noise (resistors), etc. are used. When replacing any of components, be sure to use only manufacturer's specified parts shown in the parts list.

• The supply parts number is described alone in the replacement parts.

Part No.	Original Part No.	Supply Part No.
IC202	LH5347NE	LH5347N4
IC203, 651, 801	XLU2040F-T2	XLU2040F-T1

### Caution!

IC and LSI are sensitive to static electricity. Secondary trouble can be prevented by taking care during repair.

- Cover the parts boxes made of plastics with aluminum foil.
- Ground the soldering iron.
- Put a conductive mat on the work table.
- Do not touch the pins of IC or LSI with fingers directly.

## D TUNER CIRCUIT

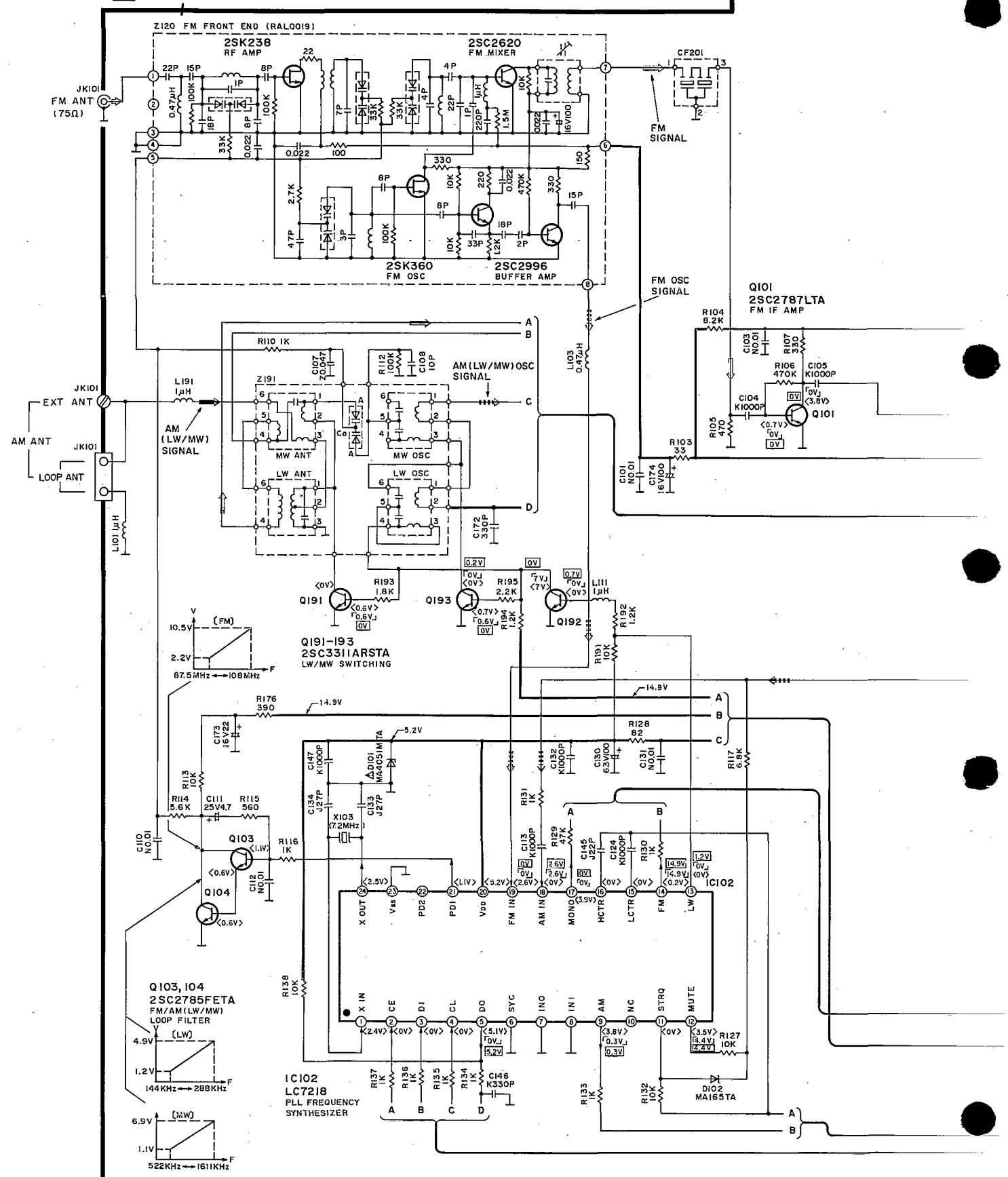



**A** SERVO CIRCUIT

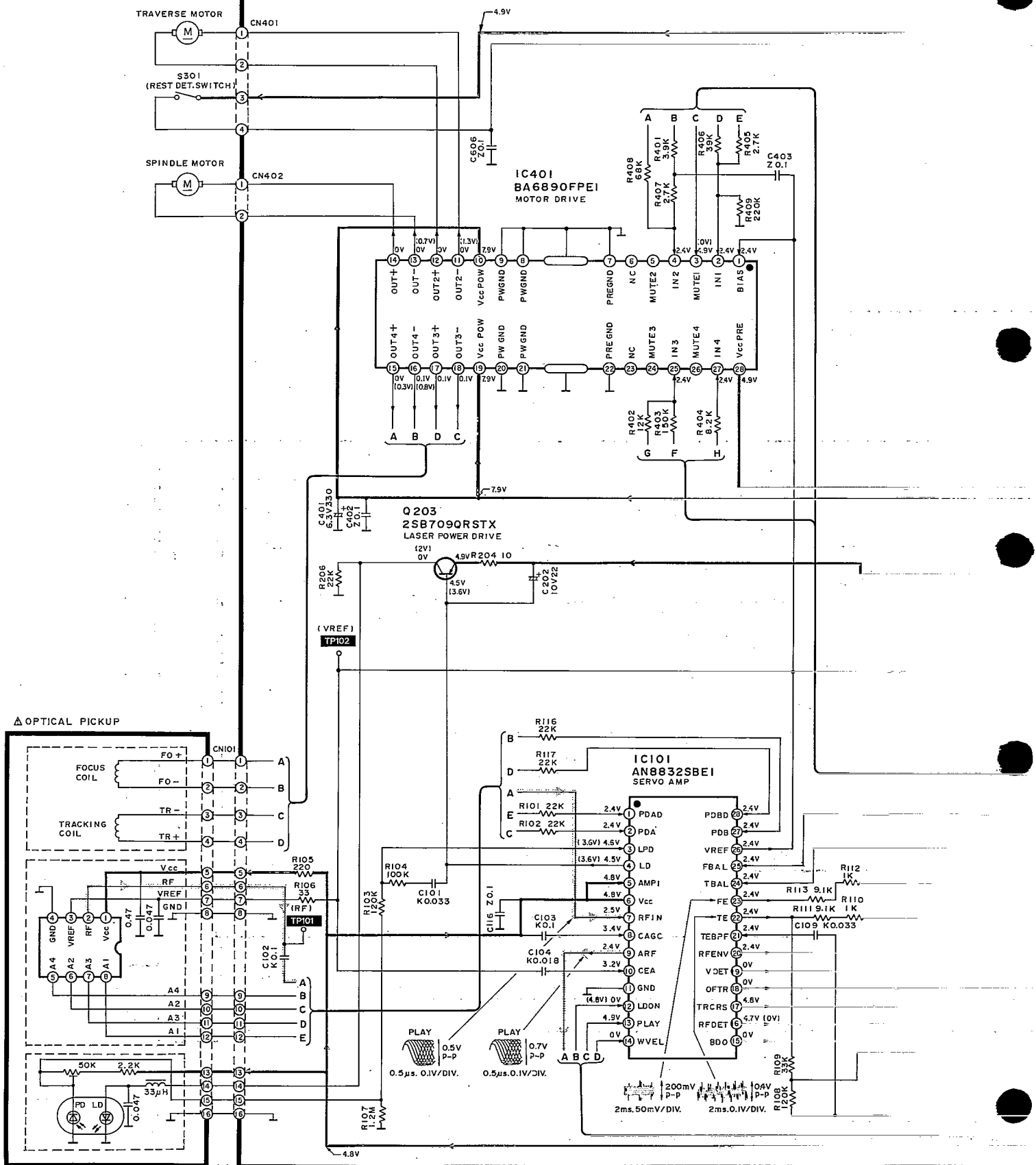









**E** MECHANISM CONTROL CIRCUIT

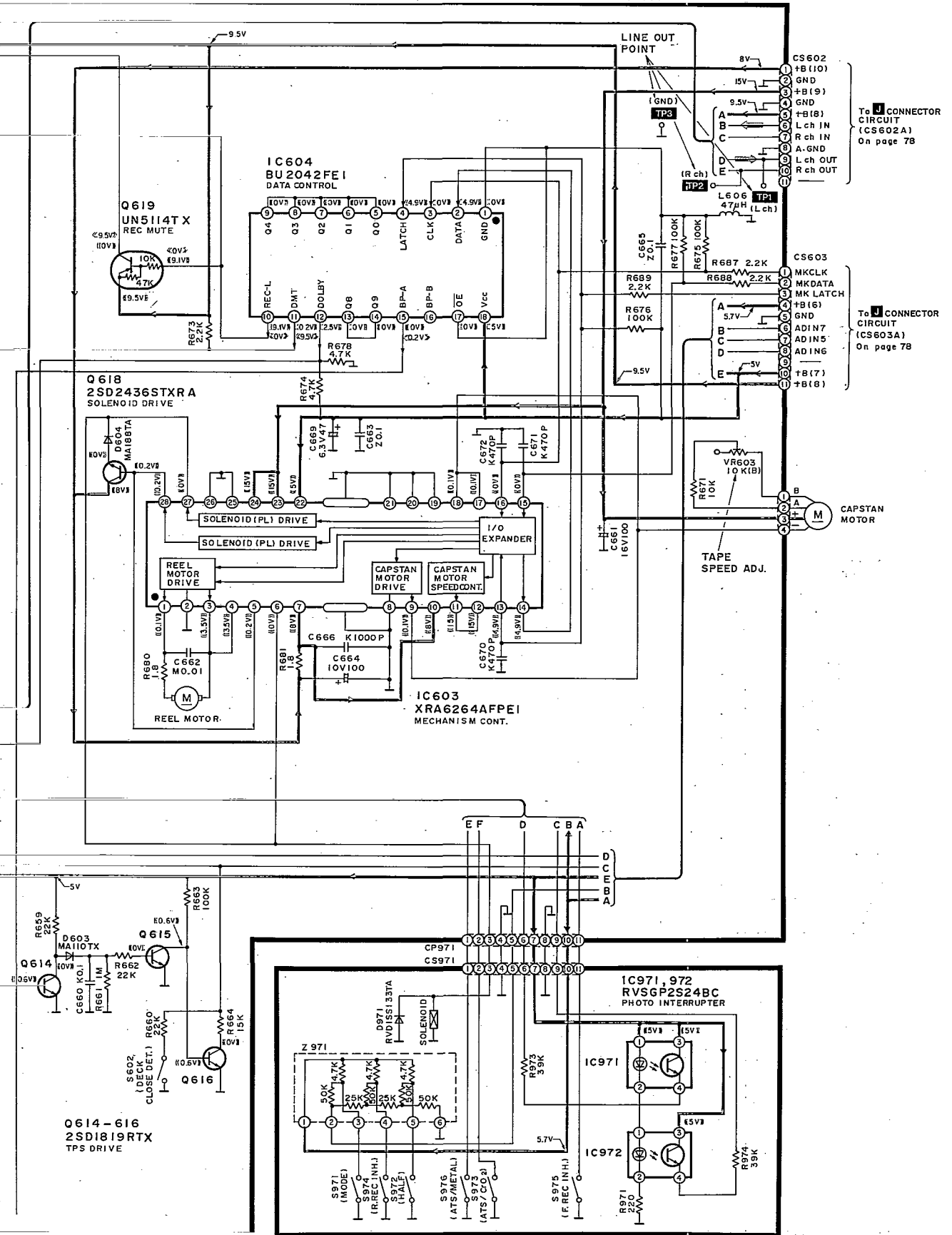

**F** MECHANISM CIRCUIT

I FL. CIRCUIT

G OPERATION CIRCUIT

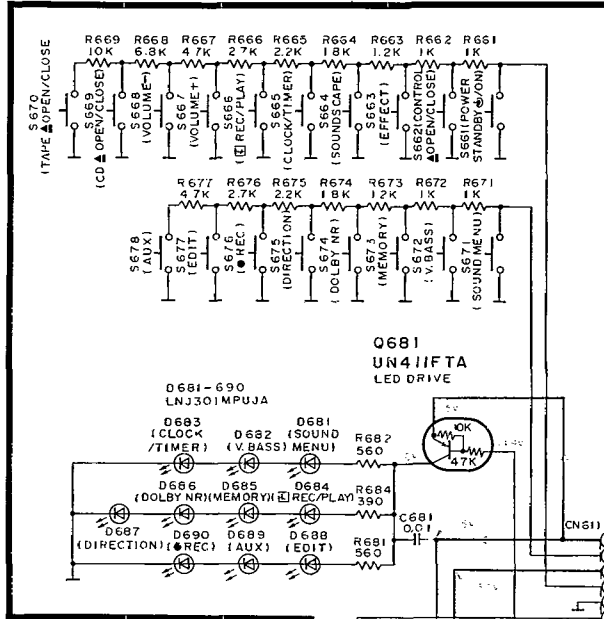

H SENSOR CIRCUIT

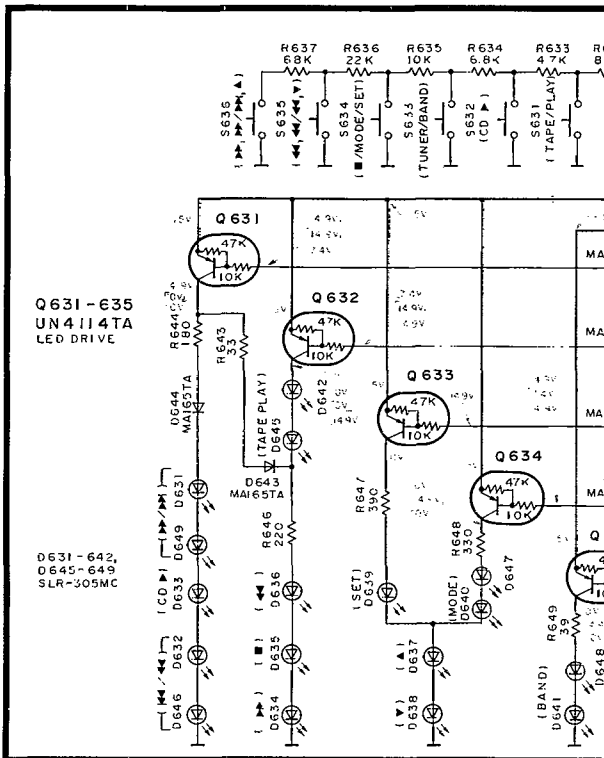
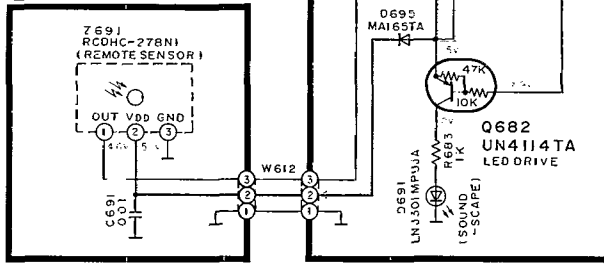

I FL CIRCUIT

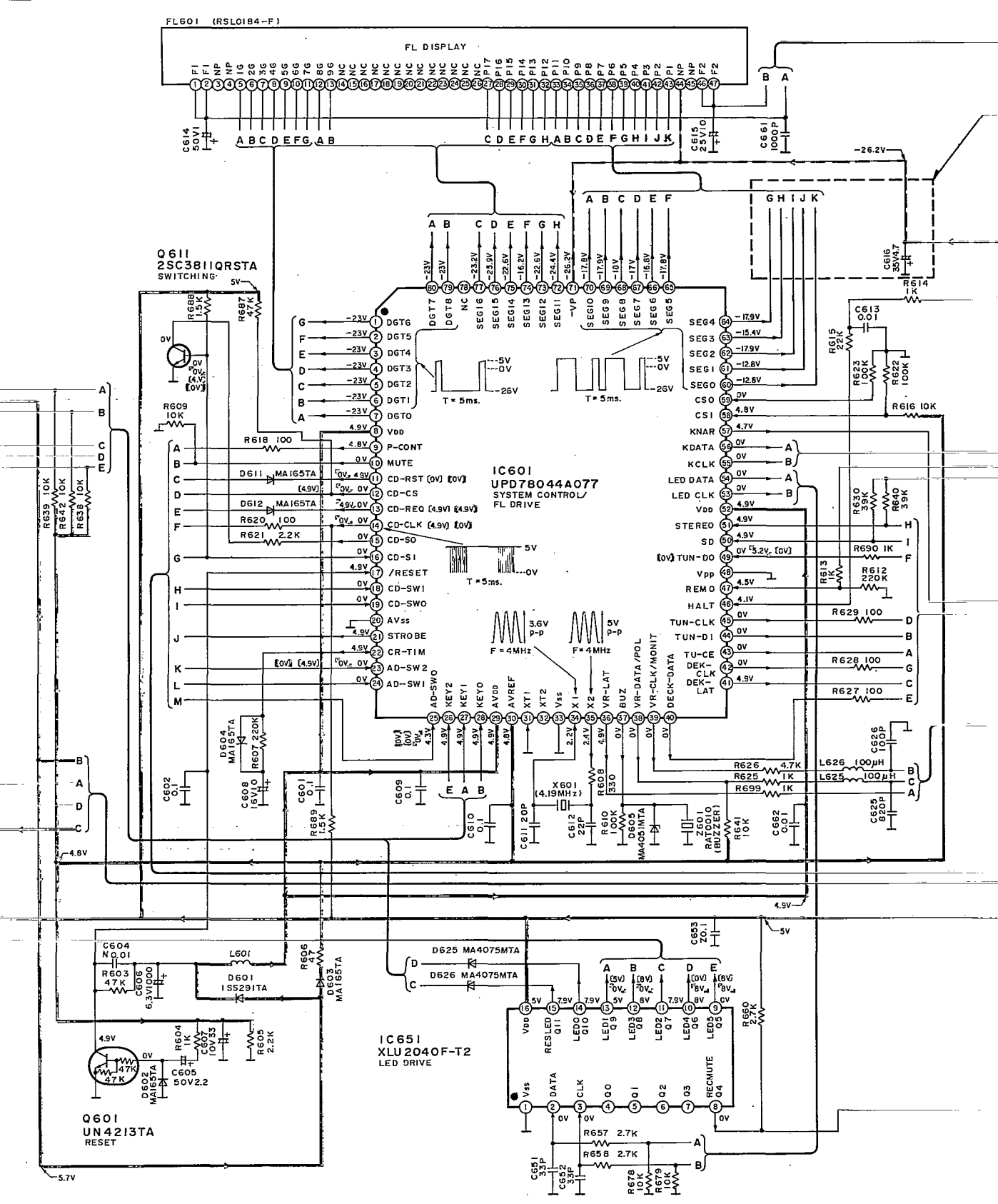

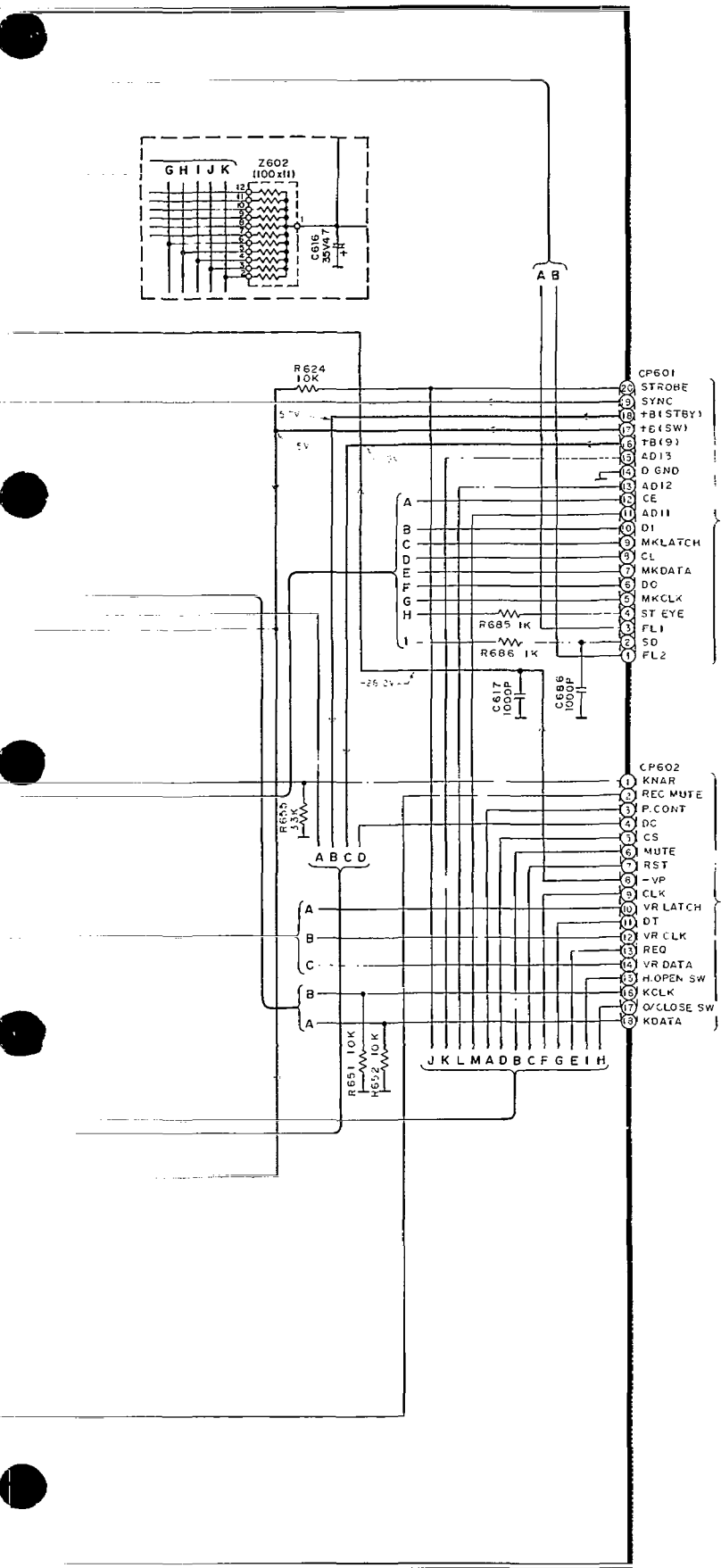

**Note:**

When replacing IC601  
 There are two different types of SA-LS10, with  
 or without a resistance array on the PCB (see  
 table).

	IC601	Resistance array	Suffix
Type A	UPD78P044077	Yes	C
Type B	UPD78044A077	None	D

For the type A unit, remove the resistance  
 array on the PCB when replacing IC601  
 (UPD78P044077). For the type B unit, simply  
 replace IC601 (UPD78044A077).

**K** MAIN CIRCUIT

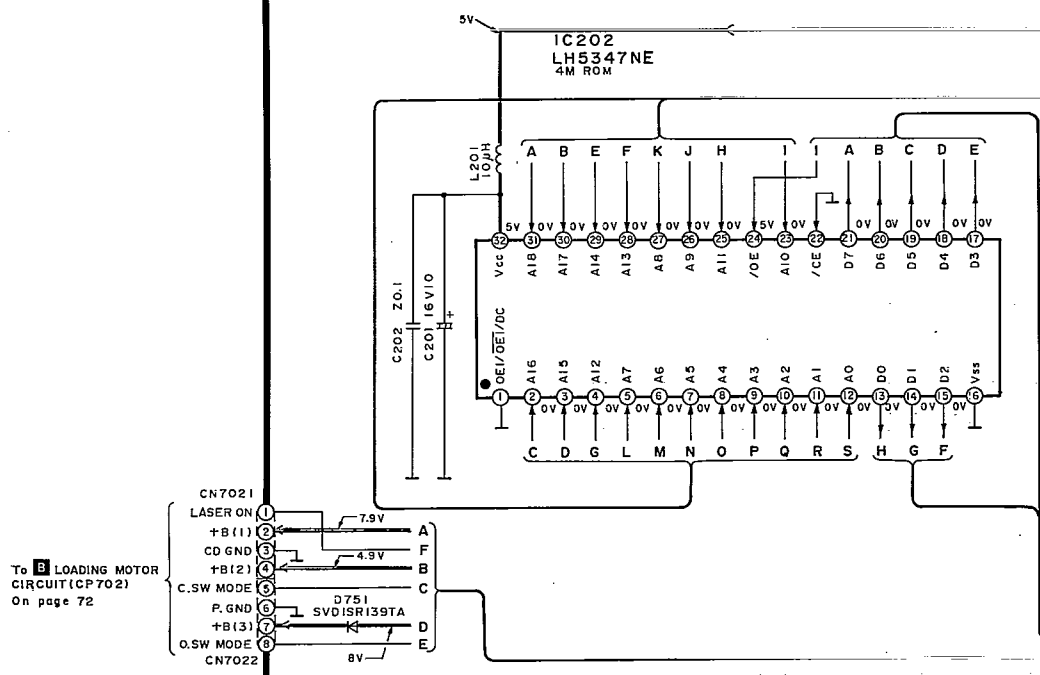

**L** POWER SUPPLY CIRCUIT

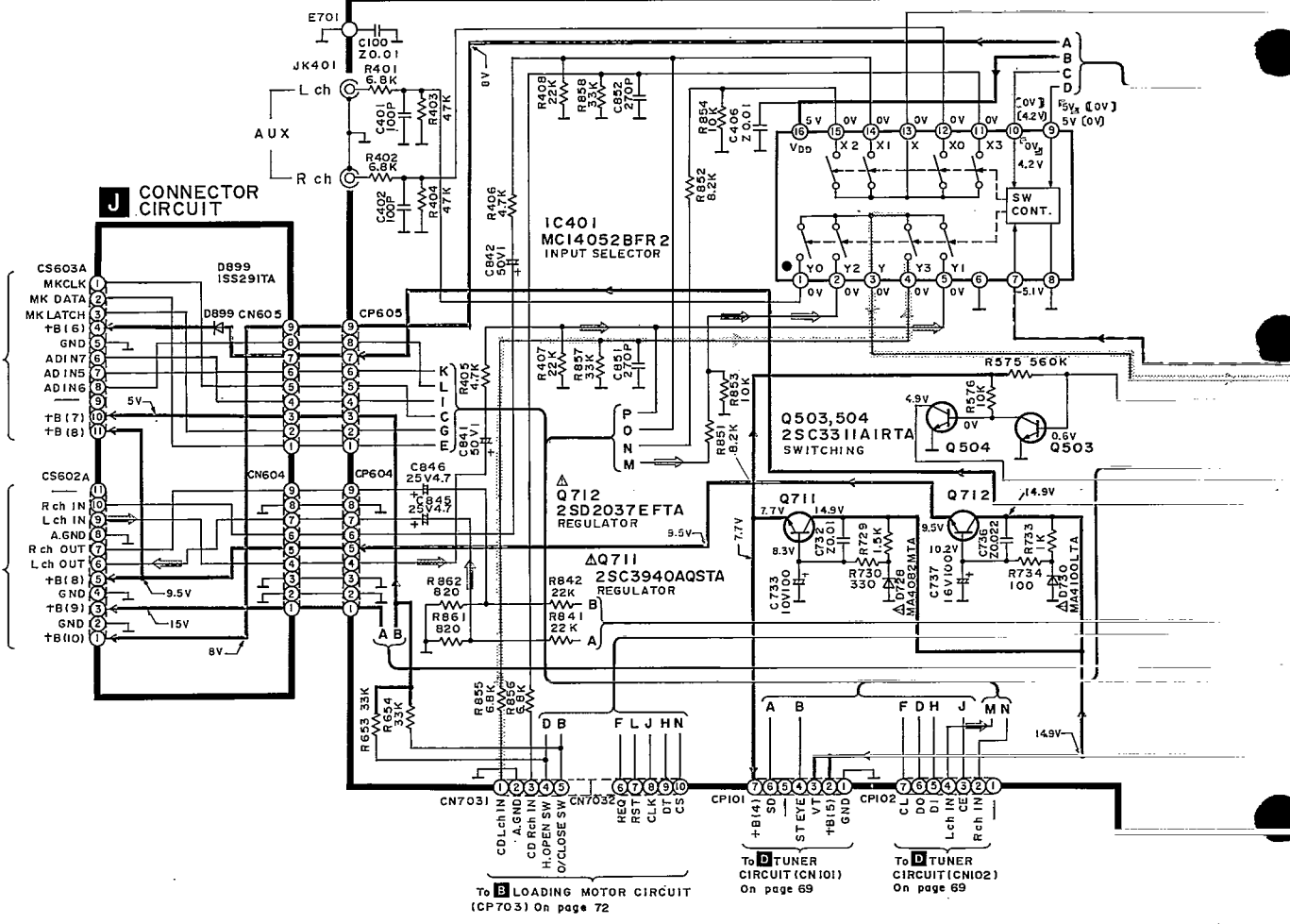

**J** CONNECTOR CIRCUIT

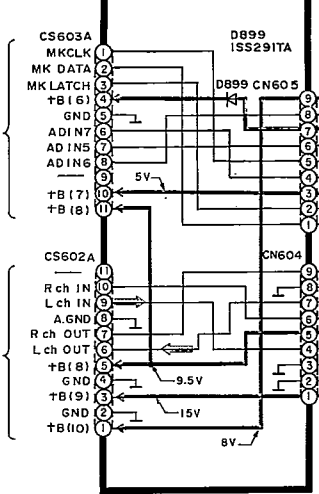



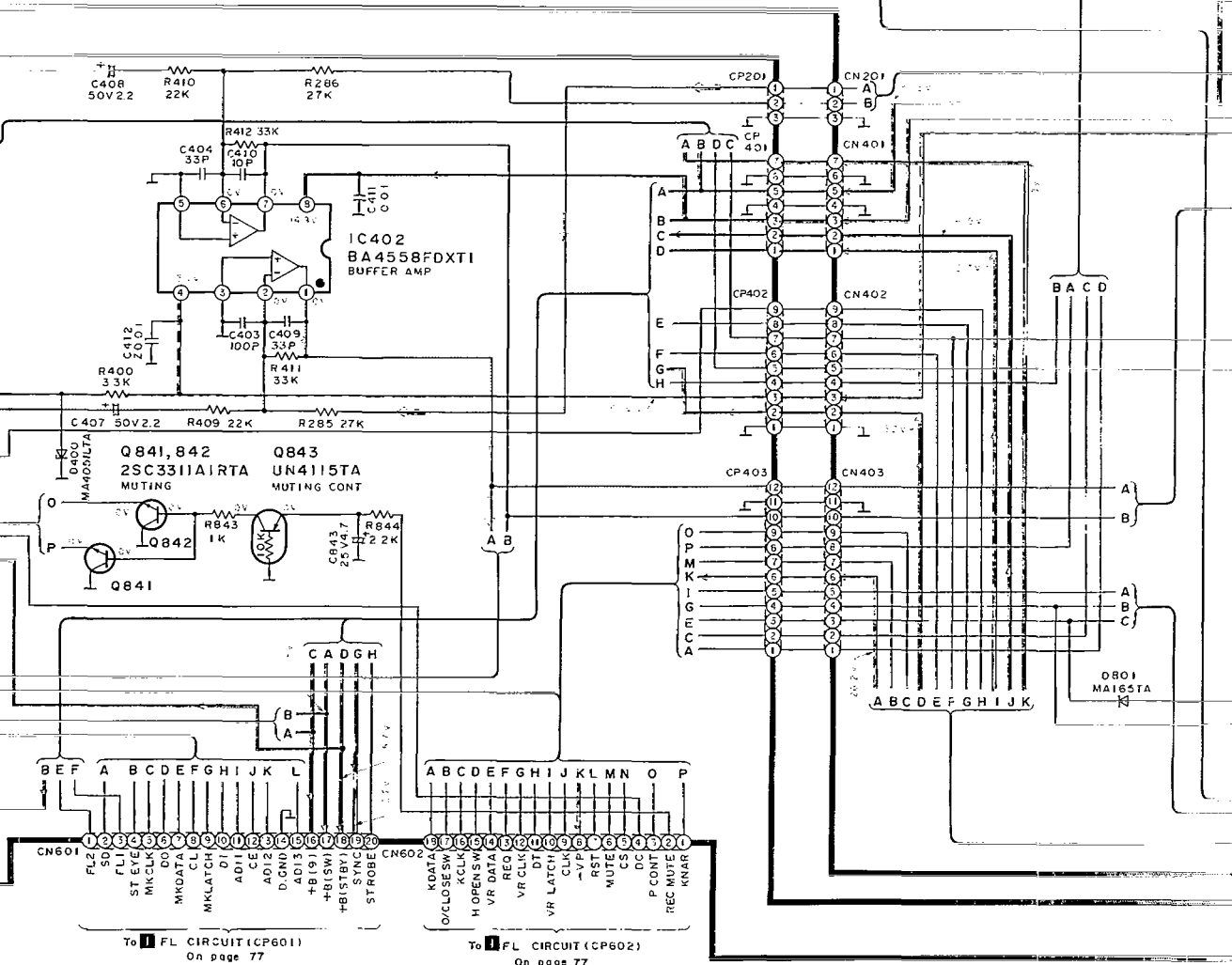
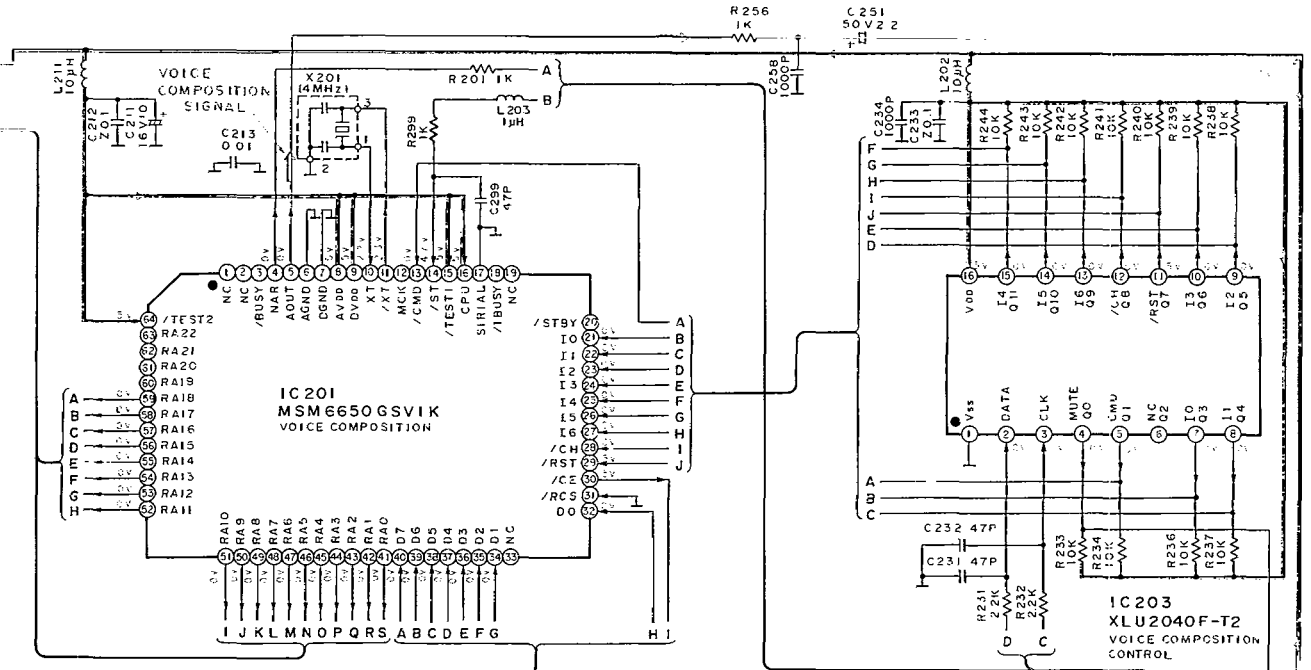

To FL CIRCUIT (CP601) On page 77

To FL CIRCUIT (CP602) On page 77

K MAIN CIRCUIT

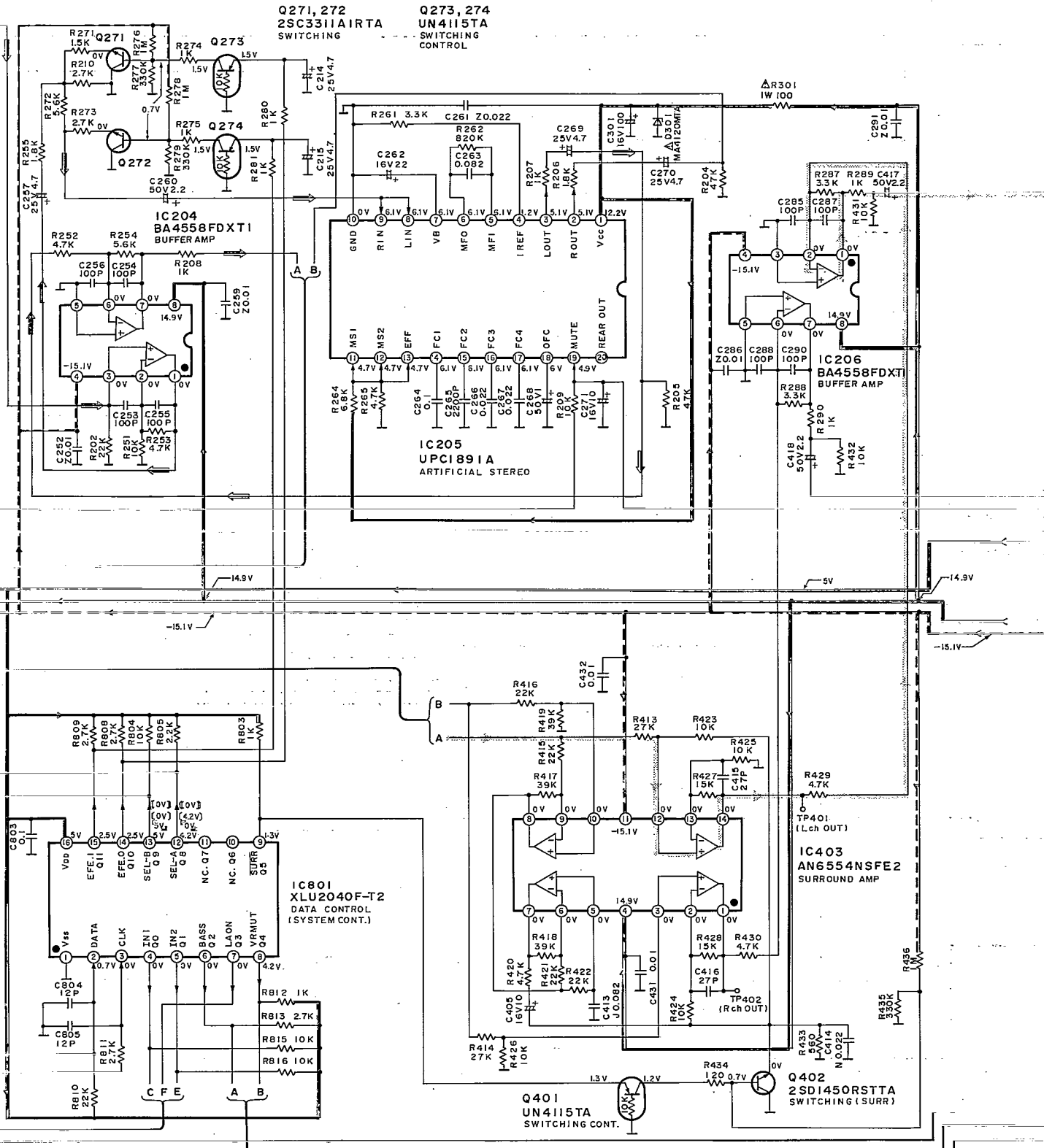



K MAIN CIRCUIT

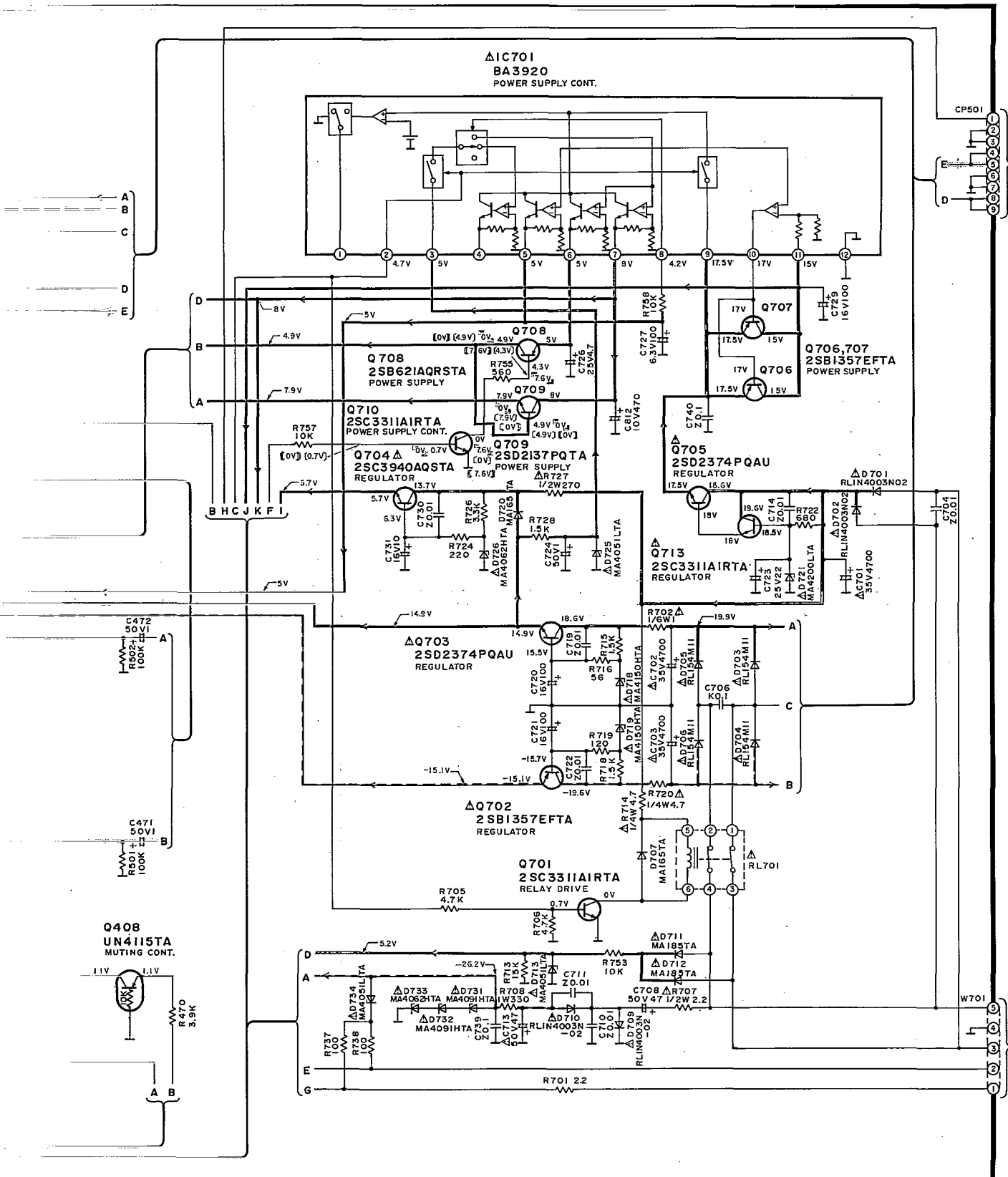

**M** SPEAKER TERMINAL CIRCUIT

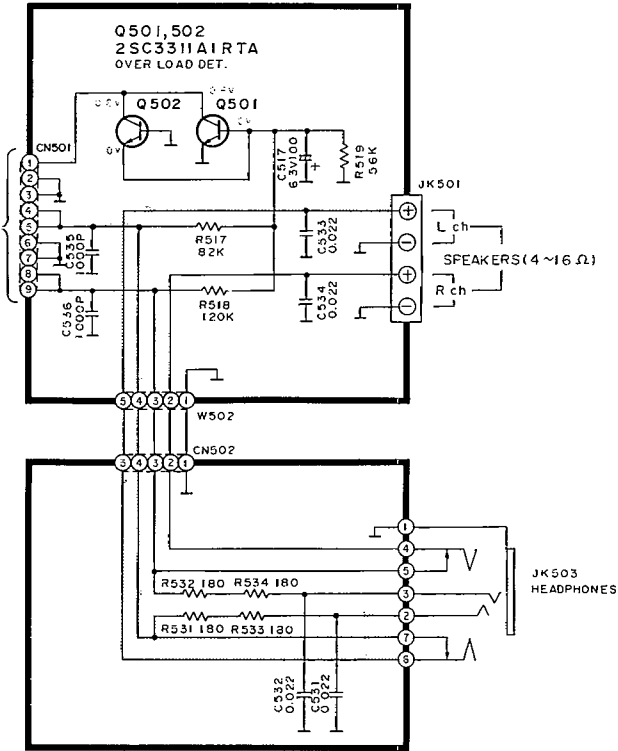

**N** HEADPHONES JACK CIRCUIT

**O** POWER TRANSFORMER CIRCUIT

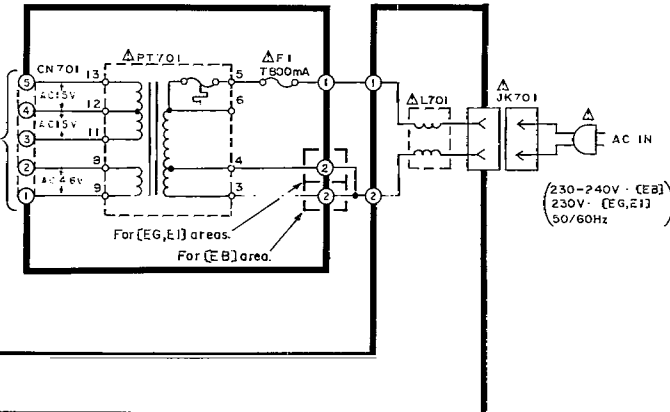

# PRINTED CIRCUIT BOARDS

A  
B  
C  
D  
E  
F  
G

**A** SERVO P.C.B.(REPI943A-T)

(RF) (VREF)  
TP101 TP102

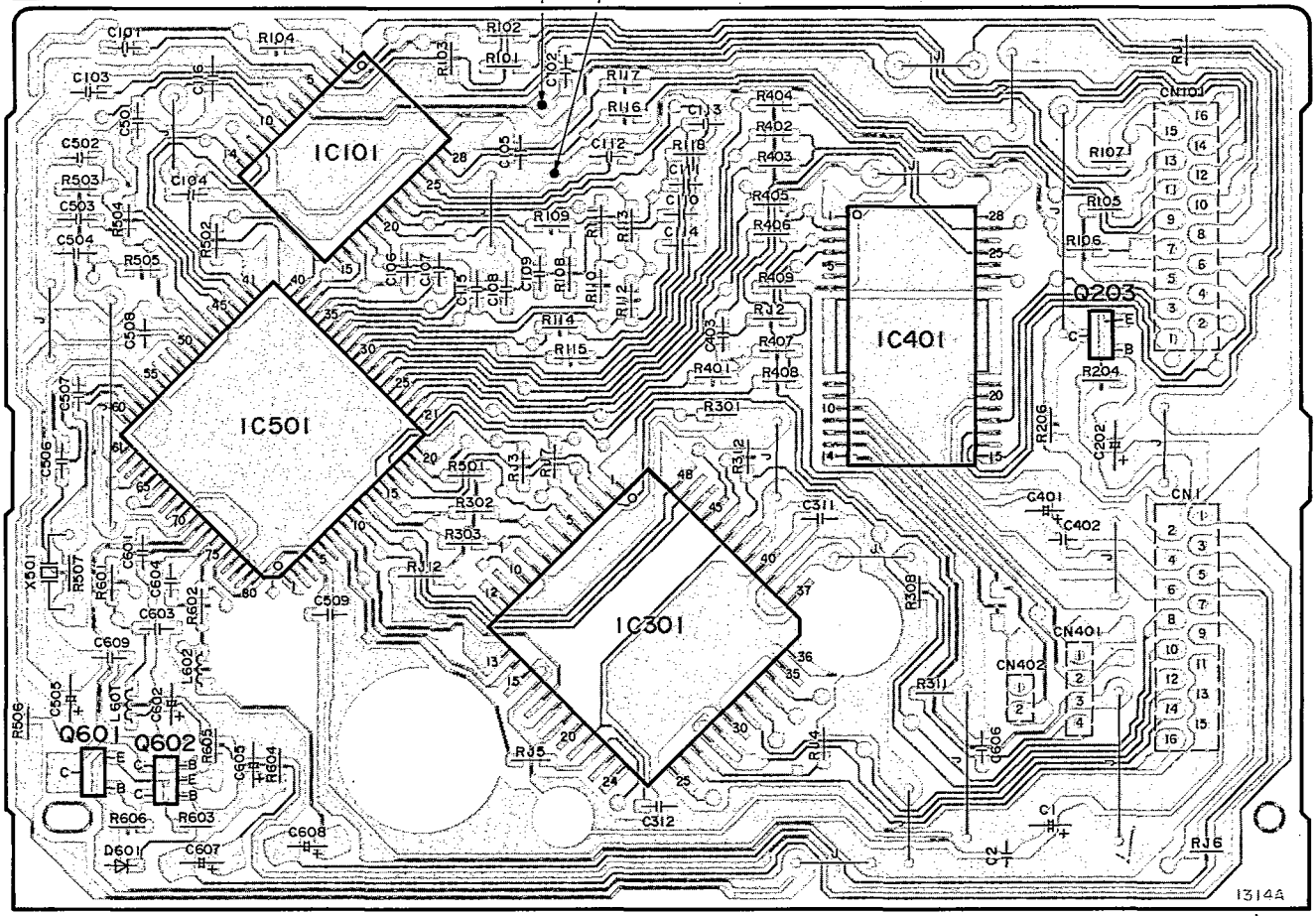

**B** LOADING MOTOR P.C.B. (REPI942B-S)

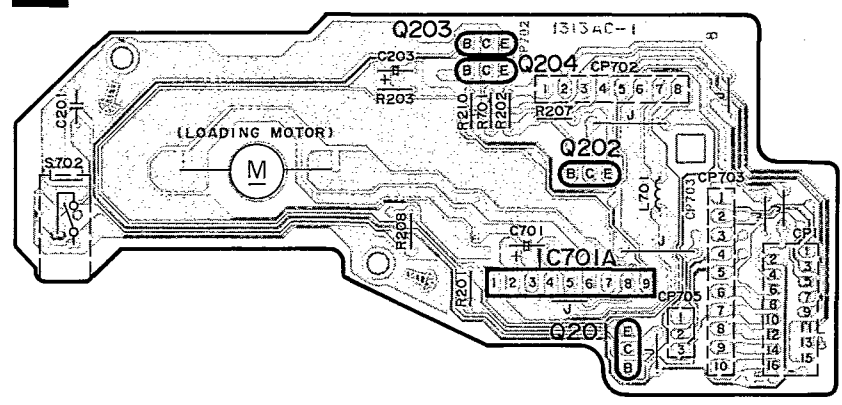

**C** SWITCH P.C.B. (REPI942B-S)

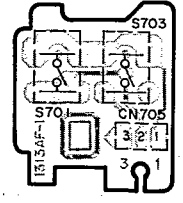

**E** MECHANISM CONTROL P.C.B. (REPI785B)

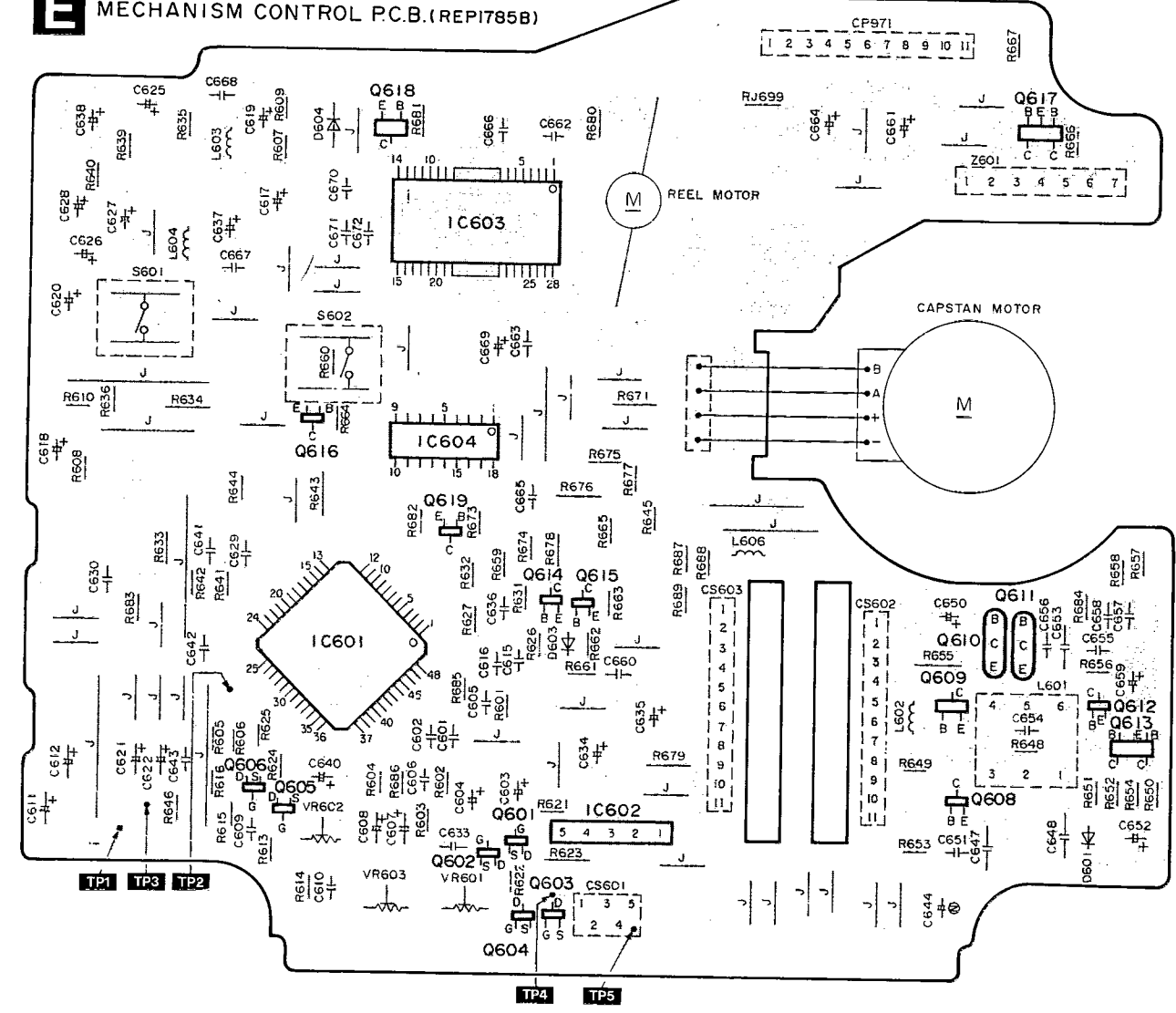

**L** POWER SUPPLY P.C.B. (REPI941B-M... (EG,EI)  
REPI941C-M... (EB)

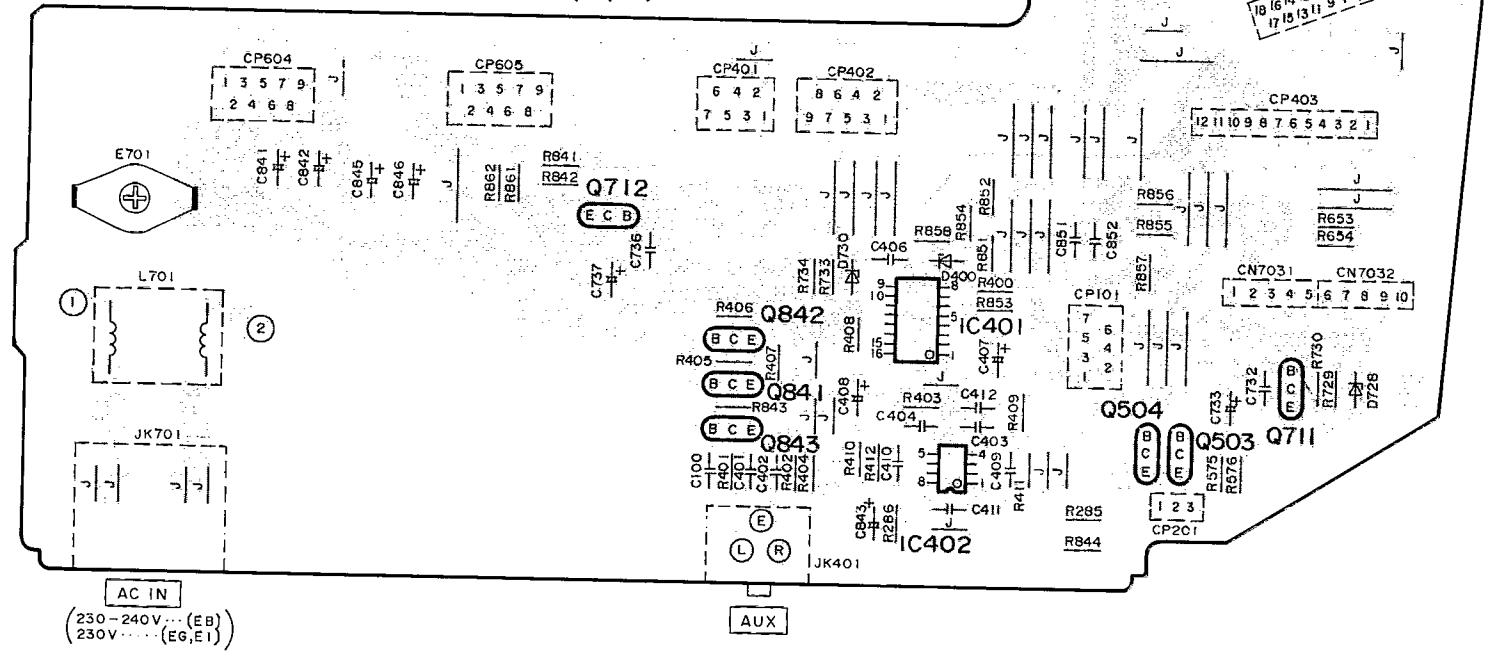

**F** MECHANISM P.C.B. (REPI656A)

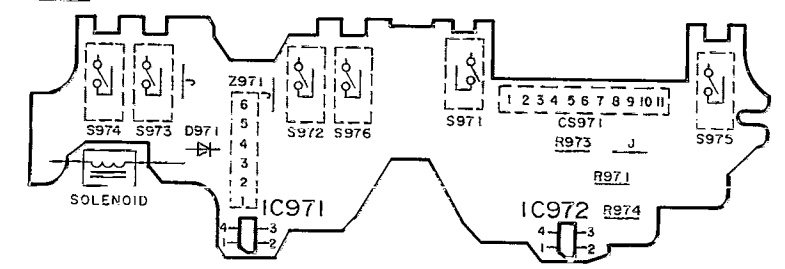

**J** CONNECTOR P.C.B. (REPI941B-M... (EG,EI)  
REPI941C-M... (EB)

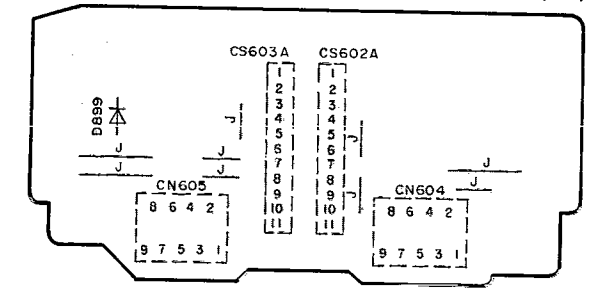

**H** SENSOR P.C.B. (REPI942B-S)

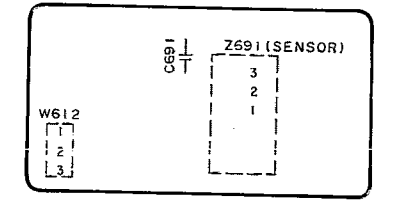

**N** HEADPHONES JACK P.C.B. (REPI942B-S)

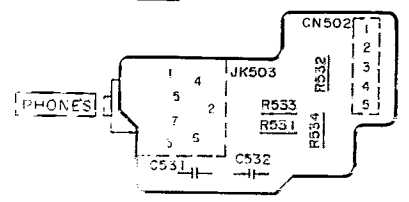

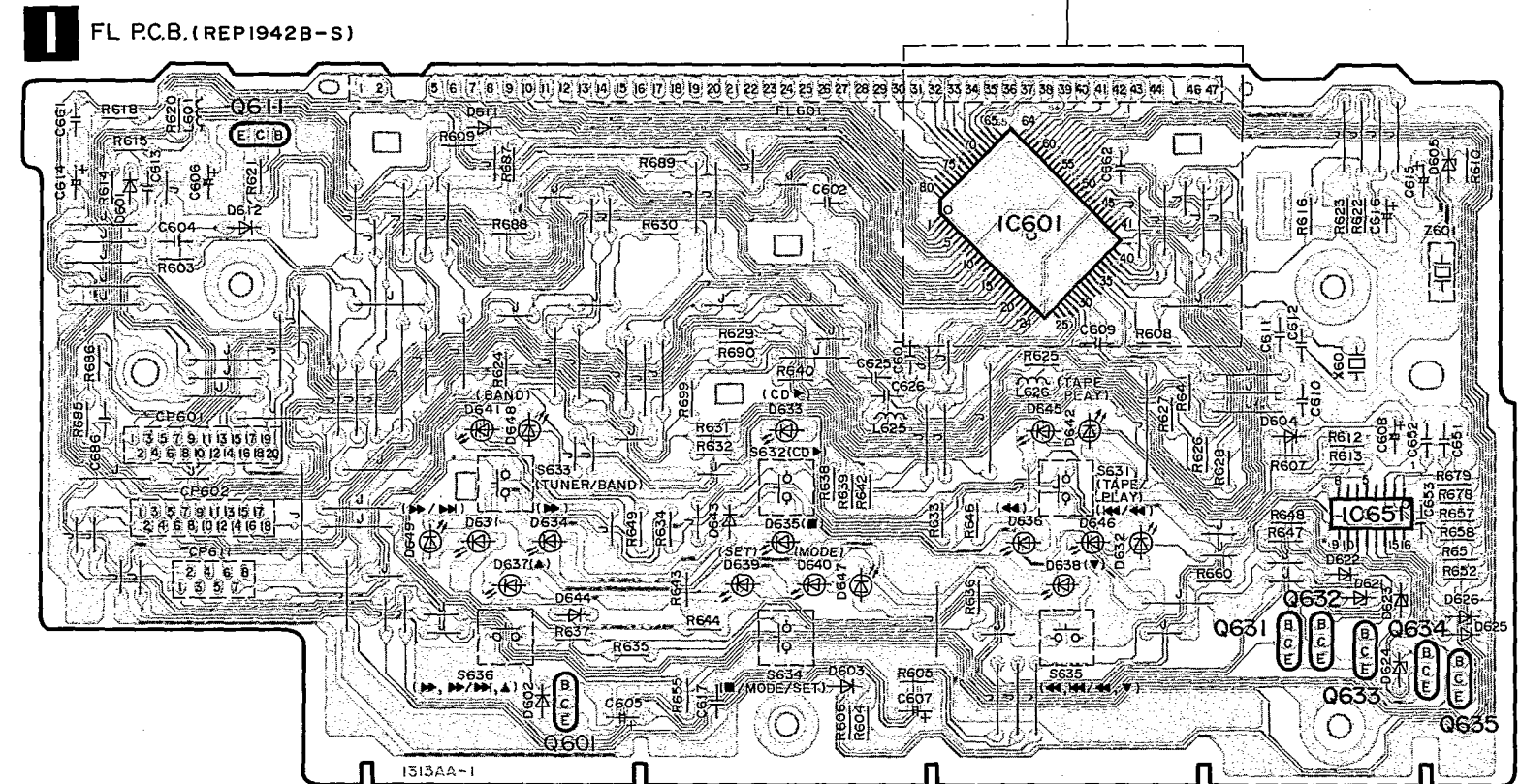
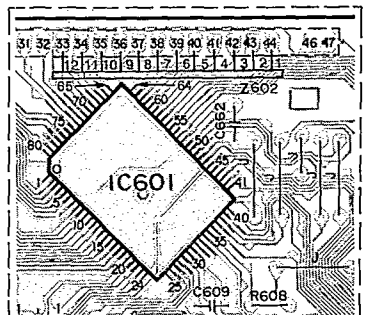
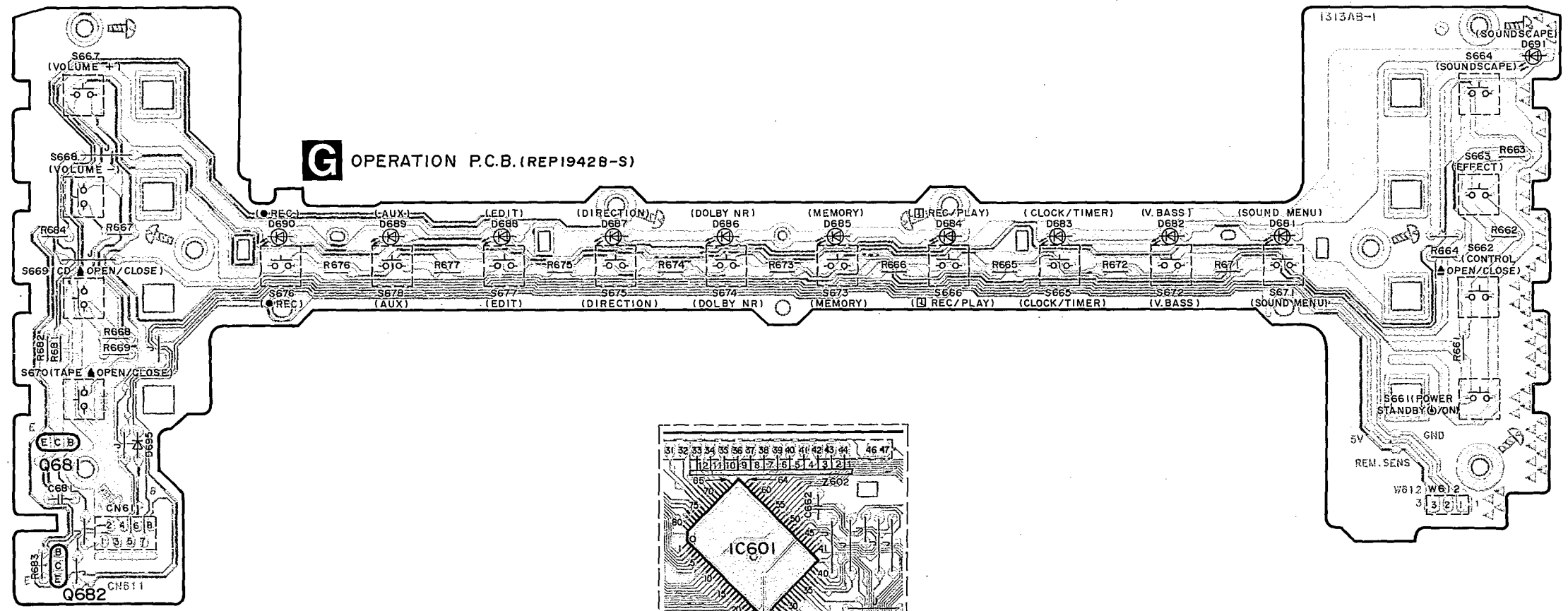

**O** POWER TRANSFORMER P.C.B. (REP1941B-M... (EG,EI) / REP1941C-M... (EB))

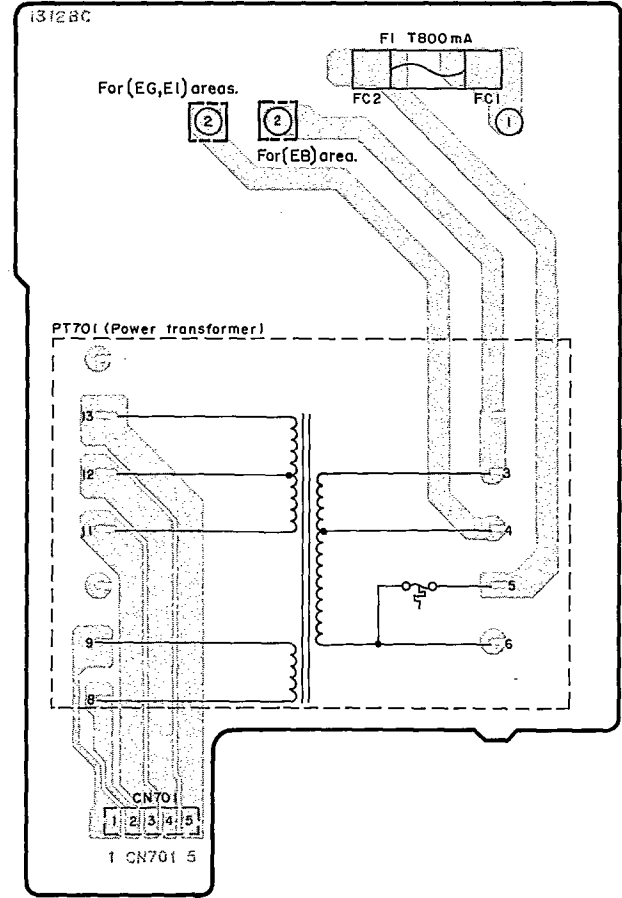



**K** MAIN P.C.B. (REPI941B-M... (EG,EI)  
REPI941C-M... (EB)

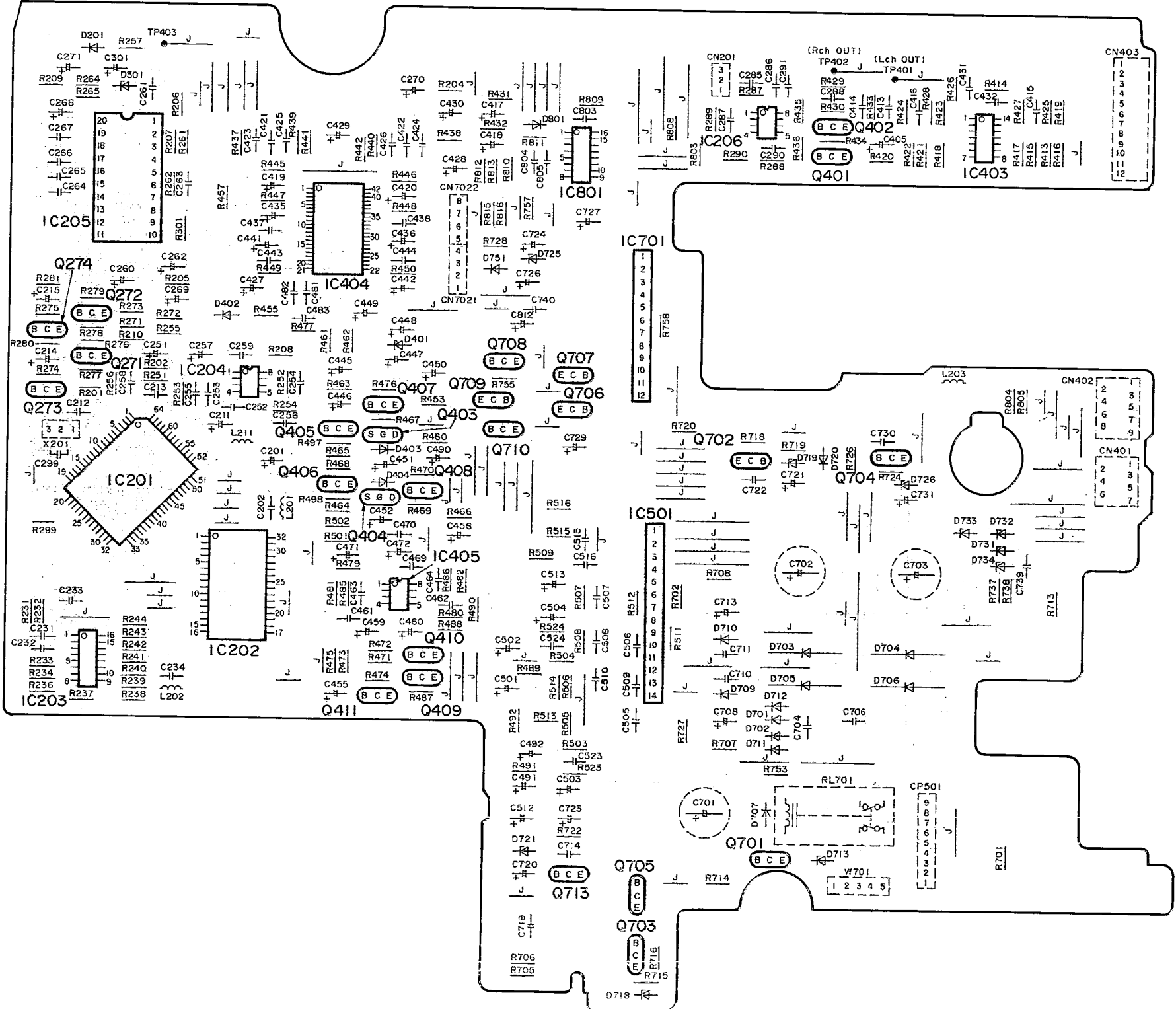

**D** TUNER P.C.B. (REPI452C-T)

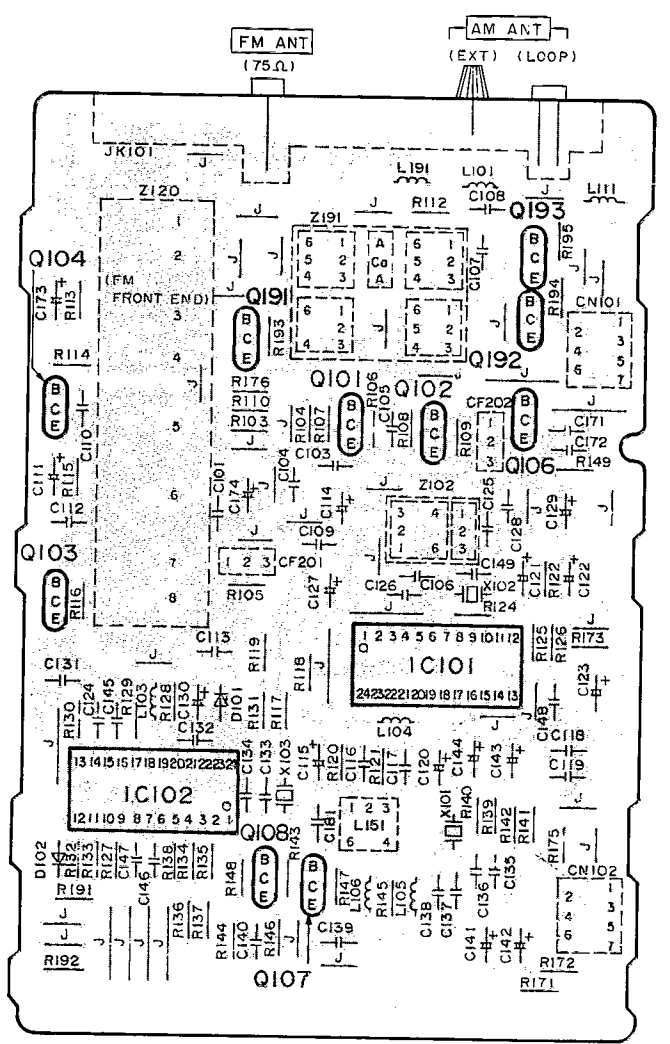

**M** SPEAKER TERMINAL P.C.B. (REPI941B-M... (EG,EI)  
REPI941C-M... (EB)

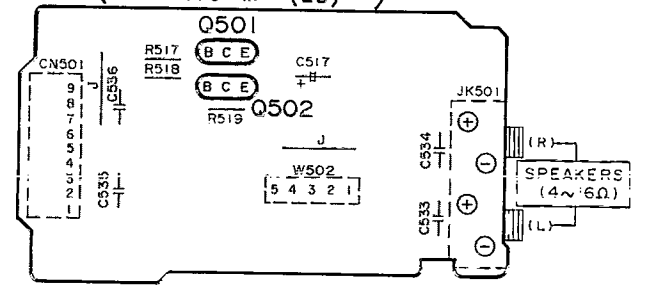

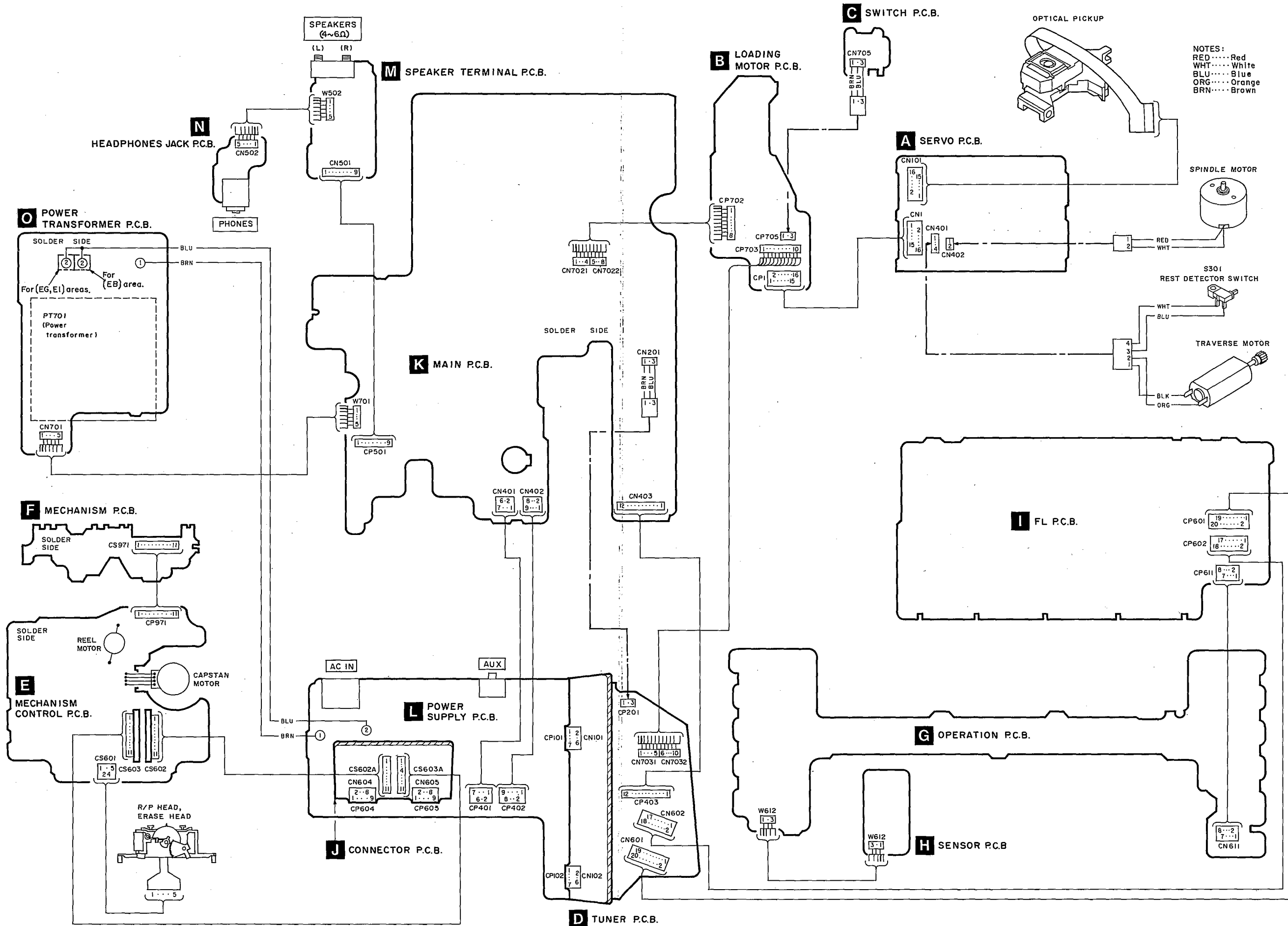

WIRING CONNECTION DIAGRAM

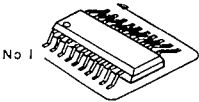
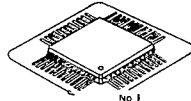
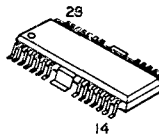
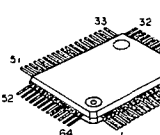
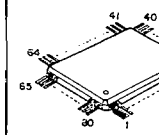
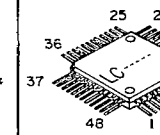
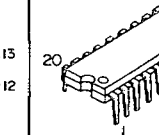
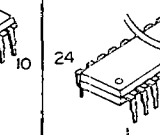
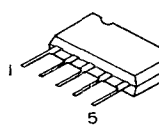
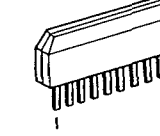
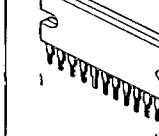
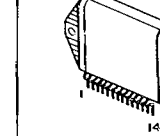
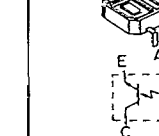
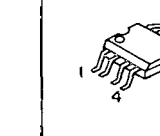
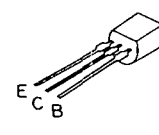
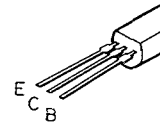
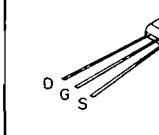
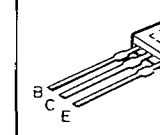
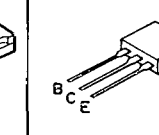
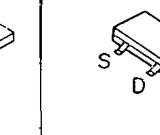
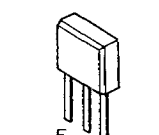
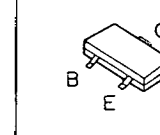
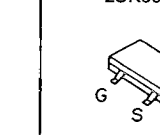

NOTES:  
 RED.....Red  
 WHT.....White  
 BLU.....Blue  
 ORG.....Orange  
 BRN.....Brown

# TERMINAL GUIDE OF IC'S TRANSISTORS AND DIODES

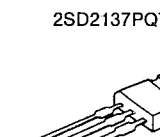
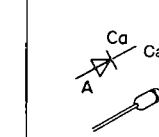
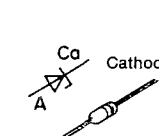
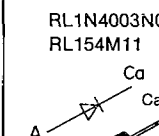
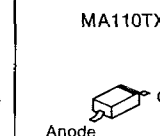
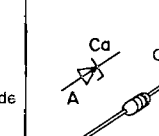
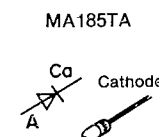
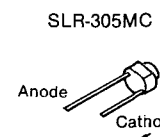
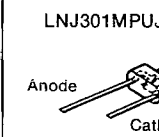
		<table border="1"> <tr> <td>AN6554NSFE2</td> <td>14 Pin</td> <td>BU2042FE1</td> <td>18 Pin</td> </tr> <tr> <td>MC14052BFR2</td> <td>16 Pin</td> <td>AN8832SBE1</td> <td>28 Pin</td> </tr> <tr> <td>XLU2040F-T2</td> <td>16 Pin</td> <td>LH5347NE</td> <td>32 Pin</td> </tr> <tr> <td>M62411FP-E1</td> <td>42 Pin</td> <td></td> <td></td> </tr> </table>		AN6554NSFE2	14 Pin	BU2042FE1	18 Pin	MC14052BFR2	16 Pin	AN8832SBE1	28 Pin	XLU2040F-T2	16 Pin	LH5347NE	32 Pin	M62411FP-E1	42 Pin			<table border="1"> <tr> <td>CXA1597QT6</td> <td>48 Pin</td> </tr> <tr> <td>MN662740RE</td> <td>80 Pin</td> </tr> </table> 		CXA1597QT6	48 Pin	MN662740RE	80 Pin
AN6554NSFE2	14 Pin	BU2042FE1	18 Pin																						
MC14052BFR2	16 Pin	AN8832SBE1	28 Pin																						
XLU2040F-T2	16 Pin	LH5347NE	32 Pin																						
M62411FP-E1	42 Pin																								
CXA1597QT6	48 Pin																								
MN662740RE	80 Pin																								
<p>BA6890FPE1 XRA6264AFPE1</p> 	<p>MSM6650GSV1K</p> 	<p>UPD78044A077</p> 	<p>LC66306A4D87</p> 	<p>UPC1891A</p> 	<p>LA1830-H LC7218</p> 																				
<p>BA7755A</p> 	<p>TA7291S</p> 	<p>BA3920</p> 	<p>SVI3101D</p> 	<p>RVSGP2S24BC</p> 	<p>3A4558FDXT1</p> 																				
<p>2SB621AQRSTA 2SC3811QRSTA</p> 	<p>2SC3940AQSTA</p> 	<p>2SK381BCTA</p> 	<p>2SB1357EFTA 2SD2037EFTA</p> 	<p>2SD2374PQAU</p> 	<p>2SJ364QTX</p> 																				
	<p>2SA1309AQSTA 2SC2785FETA 2SC2787LTA 2SC3311AIRTA 2SC3311ARSTA 2SD1450STA 2SD1450RSTTA</p>	<p>UN411FTA UN4114TA UN4115TA UN4212TA UN4213TA</p>		<p>2SB709QRSTX 2SC4102RT106 2SD1819RTX 2SD2436STXRA UN5114TX</p>	<p>2SK664TX</p> 																				
<p>XN1210TX XN1501TX FMW1T98</p> 	<p>2SD2144STA</p> 	<p>2SD2137PQTA</p> 			<p>1SS291TA MA*65TA MA*88TA MA700TA RVD1SS133TA SVD1SR139TA</p>																				
	<p>MA4100LTA MA4120MTA MA4150HTA MA4200LTA</p>		<p>RL1N4003N02 RL154M11</p>																						
<p>MA185TA</p> 	<p>SLR-305MC</p> 	<p>LNJ301MPUJA</p> 		<p>MA4051LTA MA4051MTA MA4062HTA MA4075MTA MA4082MTA MA4091HTA MA4091MTA</p>																					

## REPLACEMENT PARTS LIST

**Notes:** \*Important safety notice:

 Components identified by  $\Delta$  mark have special characteristics important for safety.

Furthermore, special parts which have purposes of fire-retardant (resistors), high-quality sound (capacitors), low-noise (resistors), etc. are used.

When replacing any of components, be sure to use only manufacturer's specified parts shown in the parts list.

\*The parenthesized indications in the Remarks columns specify the areas. (Refer to the cover page for area.)

Parts without these indications can be used for all areas.

\*Warning: This product uses a laser diode. Refer to caution statements on page 3.

\*ACHTUNG: Die Lasereinheit nicht zerlegen.

Die Lasereinheit darf nur gegen eine vom Hersteller spezifizierte Einheit ausgetauscht werden.

Ref. No.	Part No.	Part Name & Description	Remarks	Ref. No.	Part No.	Part Name & Description	Remarks
		INTEGRATED CIRCUIT(S)		Q501-504	2SC3311AIRTA	TRANSISTOR	
				Q601	UN4213	TRANSISTOR	
				Q611	2SC3811QRSTA	TRANSISTOR	
IC101	LA1830-H	FM/AM IF AMP/AM OSC		Q631-635	UN4114TA	TRANSISTOR	
IC102	LC7218	PLL FREQ. SYNTHESIZER		Q681	UN411FTA	TRANSISTOR	
IC201	MSM6650GSV1K	VOICE COMPOSITION		Q682	UN4114TA	TRANSISTOR	
IC202	LH5347N4	4M ROM		Q701	2SC3311AIRTA	TRANSISTOR	
IC203	XLU2040F-T1	VOICE COMPOSITION CONT.		Q702	2SB1357EFTA	TRANSISTOR	$\Delta$
IC204	BA4558FDXT1	BUFFER AMP.		Q703	2SD2374PQAU	TRANSISTOR	$\Delta$
IC205	UPC1891A	ARTIFICIAL STEREO		Q704	2SC3940AQSTA	TRANSISTOR	$\Delta$
IC206	BA4558FDXT1	BUFFER AMP.		Q705	2SD2374PQAU	TRANSISTOR	$\Delta$
IC401	MC14052BFR2	INPUT SELECTOR		Q706, 707	2SB1357EFTA	TRANSISTOR	
IC402	BA4558FDXT1	BUFFER AMP.		Q708	2SB621A-R	TRANSISTOR	
IC403	AN6554NSFE2	SURROUND AMP.		Q709	2SD2137PQTA	TRANSISTOR	
IC404	M62411FP-E1	ASP		Q710	2SC3311AIRTA	TRANSISTOR	
IC405	BA4558FDXT1	BUFFER AMP.		Q711	2SC3940AQSTA	TRANSISTOR	$\Delta$
IC501	SV13101D	POWER AMP.	$\Delta$	Q712	2SD2037EFTA	TRANSISTOR	$\Delta$
IC601	UPD78044A077	SYSTEM CONT. /FL DRIVE		Q713	2SC3311AIRTA	TRANSISTOR	$\Delta$
IC651	XLU2040F-T1	LED DRIVE		Q841, 842	2SC3311AIRTA	TRANSISTOR	
IC701	BA3920	POWER SUPPLY CONT.	$\Delta$	Q843	UN4115	TRANSISTOR	
IC701A	TA7291S	LOADING MOTOR DRIVE				DIODE(S)	
IC801	XLU2040F-T1	DATA CONT.		D101	MA4051MTA	DIODE	$\Delta$
IC971	RVSGP2S24BC	PHOTO INTERRUPTER		D102	MA165	DIODE	
IC972	RVSGP2S24BC	PHOTO INTERRUPTER		D201	MA165	DIODE	
		TRANSISTOR(S)		D301	MA4120	DIODE	$\Delta$
Q101, 102	2SC2787L	TRANSISTOR		D400	MA4051-L	DIODE	
Q103, 104	2SC2785FE	TRANSISTOR		D401	MA4091-M	DIODE	$\Delta$
Q106	UN411FTA	TRANSISTOR		D402	MA700TA	DIODE	
Q107, 108	2SC3311ARSTA	TRANSISTOR		D403, 404	MA165	DIODE	
Q191-193	2SC3311ARSTA	TRANSISTOR		D601	1SS291TA	DIODE	
Q201, 202	2SA1309A-R	TRANSISTOR		D602-604	MA165	DIODE	
Q203	UN4212TA	TRANSISTOR		D605	MA4051MTA	DIODE	
Q204	2SC3311AIRTA	TRANSISTOR		D611, 612	MA165	DIODE	
Q271, 272	2SC3311AIRTA	TRANSISTOR		D621-626	MA4075MTA	DIODE	
Q273, 274	UN4115	TRANSISTOR		D631-642	SLR-305MC	L. E. D.	
Q401	UN4115	TRANSISTOR		D643, 644	MA165	DIODE	
Q402	2SD145ORTA	TRANSISTOR		D645-649	SLR-305MC	L. E. D.	
Q403, 404	2SK381BCDTA	TRANSISTOR		D681-691	LNJ301MPUJA	L. E. D.	
Q405, 406	2SD2144S	TRANSISTOR		D695	MA165	DIODE	
Q407	UN4212TA	TRANSISTOR		D701, 702	RL1N4003N02	DIODE	$\Delta$
Q408	UN4115	TRANSISTOR		D703-706	RL154M11	DIODE	$\Delta$
Q409, 410	2SD145ORTA	TRANSISTOR		D707	MA165	DIODE	
Q411	UN4115	TRANSISTOR		D709, 710	RL1N4003N02	DIODE	$\Delta$

Ref. No.	Part No.	Part Name & Description	Remarks	Ref. No.	Part No.	Part Name & Description	Remarks
D711, 712	MA185TA	DIODE	△			OSCILLATOR (S)	
D713	MA4051-L	DIODE	△				
D718, 719	MA4150M	DIODE	△	X101	RSXZ456RM07M	OSCILLATOR (456KHz)	
D720	MA165	DIODE		X102	RLFDFTD03M1	OSCILLATOR (10.7MHz)	
D721	MA4200LTA	DIODE	△	X103	SVQ49U722-S	OSCILLATOR (7.2MHz)	
D725	MA4051-L	DIODE	△	X201	EF0EC4004T4	OSCILLATOR (4MHz)	
D726	MA4062-H	DIODE	△	X601	RSXA4M19S02T	OSCILLATOR (4.19MHz)	
D728	MA4082MTA	DIODE	△			DISPLAY TUBE (S)	
D730	MA4100LTA	DIODE	△				
D731, 732	MA4091HTA	DIODE	△	FL601	RSL0184-F	DISPLAY TUBE	
D733	MA4062-H	DIODE	△			FM FRONT END PACK ASS'Y(S)	
D734	MA4051-L	DIODE	△				
D751	SVD1SR139TA	DIODE		Z120	RA10019	FM FRONT END PACK	
D801	MA165	DIODE				FUSE (S)	
D899	1SS291TA	DIODE		F1	XBA2C08TB0	FLUSE 250V 800mA	△
D971	RVD1SS133TA	DIODE				SWITCH (ES)	
		COIL (S)		S631	EVQ21405R	TAPE/PLAY	
L101	ELESN1R0MA	COIL		S632	EVQ21405R	CD/PLAY	
L103	ELEXT47MA9	COIL		S633	EVQ21405R	TUNER/BAND	
L104	RLQA100JT-Y	COIL		S634	EVQ21405R	STOP/MODE SET	
L105, 106	RLQZB822KT-D	COIL		S635	EVQ21405R	R SKIP/DOWN	
L111	ELEXT1R0KA9	COIL		S636	EVQ21405R	F SKIP/UP	
L151	SLM1B10M-1M	COIL		S661	EVQ21405R	POWER STANDBY/ON	
L191	ELESN1R0MA	COIL		S662	EVQ21405R	CONTROL OPEN/CLOSE	
L201, 202	RLQA100JT-Y	COIL		S663	EVQ21405R	EFFECT	
L203	ELEXT1R0KA9	COIL		S664	EVQ21405R	SOUNDSCAPE	
L211	RLQA100JT-Y	COIL		S665	EVQ21405R	CLOCK/TIMER	
L601	RLQA100JT-Y	COIL		S666	EVQ21405R	TIMER REC/PLAY	
L625, 626	ELEXT101KA9	COIL		S667	EVQ21405R	VOLUME UP	
L701	RLQZ271M	COIL	△	S668	EVQ21405K	VOLUME DOWN	
L701A	ELESN330KA	COIL		S669	EVQ21405R	CD OPEN/CLOSE	
		TRANSFORMER (S)		S670	EVQ21405R	TAPE OPEN/CLOSE	
PT701	RTP4H5B001-X	POWER TRANSFORMER	△	S671	EVQ21405R	SOUND MENU	
		COMPONENT COMBINATION (S)		S672	EVQ21405R	V. BASS	
Z102	RL12Z006M-T	COMPONENT COMBINATION		S673	EVQ21405R	MEMORY	
Z191	RLA6Z005M-T	COMPONENT COMBINATION		S674	EVQ21405R	DOLBY NR	
Z601	RAT0010	BUZZER		S675	EVQ21405R	DIRECTION	
Z602	EXBF12E473J	COMPONENT COMBINATION		S676	EVQ21405R	REC	
Z691	RCDHC-278N	REMOTE SENSOR		S677	EVQ21405R	EDIT	
Z971	EXBF6L306SYV	COMPONENT COMBINATION		S678	EVQ21405R	AUX	
		FILTER (S)		S701	RSH1A024-U	OPEN/CLOSE DETECTOR	
CF201	RLFFETNGD01L	FILTER		S702	RSH1A005	LASER ON/OFF	
CF202	RLFFETNGD01L	FILTER		S703	RSH1A024-U	HALF OPEN DET.	
				S971	RSH1A018-U	MODE DET.	
				S972	RSH1A019-U	HALF DET.	
				S973	RSH1A019-U	ATS/C+02 DET.	



Ref. No.	Part No.	Part Name & Description	Remarks	Ref. No.	Part No.	Part Name & Description	Remarks
		<MECHANISM CONT. P. C. B. >					
		INTEGRATED CIRCUIT(S)					
IC601	CXA1697QT6	P/R AMP. /DOLBY NR/AGC/TPS		CP971	RJT071H11A	CONNECTOR(11P)	
IC602	BA7755A	R/P SELECT		CS601	RJS2A0205M1S	CONNECTOR(5P)	
IC603	XRA6264AFPE1	MECHANISM CONT.		CS602	RJU071H11M	SOCKET(11P)	
IC604	BU2042FE1	DATA CONTROL		CS603	RJU071H11M	SOCKET(11P)	
		TRANSISTOR(S)				CABINET AND CHASSIS	
Q601, 602	2SJ364QTX	TRANSISTOR		1	RHD30007	SCREW	
Q603, 604	2SK664TX	TRANSISTOR		2	RKF0379A-K	BACK GRIL	
Q605, 606	2SJ364QTX	TRANSISTOR		3	XTBS3+8JFZ1	SCREW	
Q608	2SC4102RT106	TRANSISTOR		4	RWJ1805130XX	FLAT CABLE(5P)	
Q609	2SD2436STXRA	TRANSISTOR		5	RWJ1810520QQ	FLAT CABLE(10P)	
Q610, 611	2SD1450RTA	TRANSISTOR		6	RWJ1808400XX	FLAT CABLE(8P)	
Q612	2SD1819RTX	TRANSISTOR		7	RWJ1805590XX	FLAT CABLE(5P)	
Q613	XN1210TX	TRANSISTOR		8	RGR0196B-B1A	REAR PANEL	(EB)
Q614-616	2SD1819RTX	TRANSISTOR		8	RGR0196B-A1A	REAR PANEL	(EG)
Q617	XN1501TX	TRANSISTOR		8	RFKHALS10EI	REAR PANEL ASS'Y	(EI)
Q618	2SD2436STXRA	TRANSISTOR		9	RMC0158	TRANSISTOR ORNAMENT	
Q619	UN5114TX	TRANSISTOR		10	RFKNALS10AK	SHIELD PLATE ASS'Y	
		DIODE(S)		11	RFKJALS10EB	BOTTOM CHASSIS ASS'Y	
D601	MA110TX	DIODE		11-1	RKA0061B-K1	FOOT	
D603	MA110TX	DIODE		12	RMN0203	P. C. B. HOLDER	
D604	MA188TA	DIODE		13	RMN0288	SPACER	
		VARIABLE RESISTOR(S)		14	RMRO788-W	CONNECTOR GUIDE	
VR601, 602	RRN6B05B24TA	PLAYBACK GAIN ADJ.		15	RMN0195	FL HOLDER PIECE	
VR603	RRN6B05B14TA	TAPE SPEED ADJ.		16	RMN0278	FL HOLDER	
		COIL(S)		17	RFKNALS10BK	POWER BUTTON ASS'Y	
L601	RL08C006M-T	COIL		18	RGU1097-K	RESORT BUTTON	
L602	RLQU470KT-W	COIL		19	RFKGALS10AK	FRONT PANEL ASS'Y	
L603, 604	ELJFB102KF	COIL		19-1	RKA0061B-K1	FOOT	
L606	RLQU470KT-W	COIL		20	RGU1078-Q	FUNCTION SHINE-AUT BUTTON	
		COMPONENT COMBINATION(S)		21	RGU1082-K	VOLUME UP BUTTON	
Z601	EXBF7L355SYV	COMPONENT COMBINATION		22	RGU1083-K	VOLUME DOWN BUTTON	
		SWITCH(ES)		23	RGU1084-K	CASSETTE OPEN BUTTON	
S601	RSH1A024-U	DECK OPEN DET.		24	RGU1085-K	CD CONTROL BUTTON	
S602	RSH1A024-U	DECK CLOSE DET.		25	RGU1086-K	CD OPEN BUTTON	
		CONNECTOR(S) AND SOCKET(S)		26	RGU1098-K	EFFECT BUTTON	
				27	RMB0367	BALANCE SPRING(L)	
				28	RMB0371	BUTTON SPRING	
				29	RMB0377	BALANCE SPRING(R)	
				30	RMN0280	SHINE-AUT LED CASE	
				31	RMN0285	HEADPHONE HOLDER PIECE	
				32	RMS0480	CASSETTE PANEL SHAFT	
				33	RMV0082	LED SHEET	
				34	RDG0282	DRIVE GEAR	
				35	RDG0283	GEAR(A)	
				36	RDG0285	CD LOADING GEAR(L)	
				37	RDG0286	CD LOADING GEAR(R)	
				38	RDPO073	CD ROLLER	
				39	RDPO076	TENSION ROLLER(A)	
				40	RDPO077	TENSION ROLLER(B)	

Ref. No.	Part No.	Part Name & Description	Remarks	Ref. No.	Part No.	Part Name & Description	Remarks
41	RFKLALS10EB	CD DOOR ASS'Y		90	RFKNALS10DK	GEAR BOX(A) ASS'Y	
42	RFKNALS10EGK	CD MECHA. BASE ASS'Y		91	XTW3+15T	SCREW	
43	RSC0393	SHIELD PLATE		92	XTW3+8T	SCREW	
44	RMB0382	TENSION SPRING		93	XTB2+10G	SCREW	
45	RMG0370-K	TIMING BELT		94	RMCO246	EARTH PLATE	
46	RMG0371-K	CD COVER RUBBER		95	RMZ0299	INTERRUPT HEAT SHEET	
47	RML0347	LASER SW LEVER		96	RSC0406	MOTOR SHIELD PLATE	
48	RML0358	BELT TENSION ARM					
49	RMRO701-K	ROLLER(B)				MECHANISM PARTS	
50	RMRO775-W	BELT HOLDER					
51	RMRO785-K	CD COVER GUIDE PIECE		101	RXF0045	FLYWHEEL (F)	
52	RMRO787-W	SHAFT RECEIVER		101-1	RMQ0420	WASHER	
53	RMRO817-W	TENSION ROLLER HOLDER		102	RXF0046	FLYWHEEL (R)	
54	RMS0476	CD COVER OPEN/CLOSE SHAFT		102-1	RMQ0421	WASHER	
55	RMS0477	DOOR OPEN/CLOSE SHAFT		103	RML0272	SWITCH LEVER	
56	RDG0281	PULLEY GEAR		104	RXQ0265	HEAD P. C. B. ASS'Y	
57	RDG0287	ROLL GEAR		104-1	RMB0266-1	SPRING	
58	RFKPALS10-K	MOTOR ASS'Y		104-2	RXM0036	REG./REF. ROD ASS'Y	
59	RMG0121	MOTOR BELT		105	RGH0582-K	ORNAMENT PLATE	
60	XTB3+8JFZ	SCREW		106	RXQ0316-1	HEAD BLOCK ASS'Y	
61	XUC2FT	E RING		106-1	RHD17015	SCREW, AZIMUTH ADJUSTMENT	
62	XYN26+C5	MOTOR SCREW		106-2	RMB0352	SPRING, AZIMUTH ADJUSTMENT	
63	RDG0284	GEAR (B)		106-3	RMQ0360A	CONNECTOR HOLDER	
64	RMB0286	SW LEVER SPRING		107	RDV108ZA	BELT	
65	RML0345	END DETECT LEVER		108	RDK0019A	MAIN GEAR	
66	RFKNALS10EK	GEAR BOX(B) ASS'Y		109	RMB0261	SPRING	
67	RMRO790-W	BELT HOLDER PIECE		110	RMB0262	SPRING	
68	RMS0486	DETECT LEVER SHAFT		111	RMB0263	SPRING (F)	
69	RAE0135Z	TRAVERSE DECK ASS'Y		112	RMB0264	SPRING (R)	
69-1	SHGD157	FLOATING RUBBER(A)		113	RJW147ZA	SPRING	
69-2	SHGD165	FLOATING RUBBER(B)		114	RML0267A	TRIGGER LEVER	
70	REZ0701	FLEXIBLE P. C. B. (16P)		115	RML0268A	REG. /REF. LEVER	
71	RKM0267-N1	CD CABINET (UPPER)		116	RM0091A	BAKE ROD	
72	RKS0178-H1	CD CABINET (LOWER)		117	RMS0398-1	MOVING IRON CORE	
73	RMRO786-C	CD BLOCK GUIDE PIECE		118	RSJ0003	SOLENOID UNIT	
74	SHGD112	CUSHION RUBBER (A)		119	RUS609ZC	SPRING	
75	REZ0698	FLEXIBLE P. C. B. (20P)		120	RXG0036	REEL GEAR	
76	REZ0699	FLEXIBLE P. C. B. (18P)		121	RXL0106	IDLER LEVER UNIT	
77	REZ0700	FLEXIBLE P. C. B. (8P)		122	RXP0052	PINCH ARM UNIT (F)	
78	RFKGALS10BK	DECK PANEL ASS'Y		122-1	RMB0259	SPRING	
78-1	RKW0347-V	FL WINDOW		123	RXP0053	PINCH ARM UNIT (R)	
79	RGZ0023-K	SELECTOR BUTTON ASS'Y		123-1	RMB0260	SPRING	
80	RGL0247-Q	PANEL LIGTH		124	RDG0206A-1	LOADING GEAR	
81	RKF0381-K	DECK REVERSE SIDE COVER		125	RDG0209A	INTERMEDIATE GEAR	
82	RMG0249-K1	CUSHION RUBBER (B)		126	REM0036-1	CAPSTAN MOTOR UNIT	
83	RMNO279	LED CASE		127	REM0043	REEL MOTOR	
84	RMRO776-K	PANEL HOLDER		128	RHD26013	SCREW	
85	XTBS26+8J	SCREW		129	RMCO169	RACK HOLDER PLATE	
86	SHE187-2	P. C. B. SUPPORT		130	RMQ0314A	SURASUTO SPACER	
87	XTB3+12JFZ	SCREW		131	RXG0037	FUNCTION GEAR ASS'Y	
88	XTB3+20JFZ	SCREW		132	RYF0226-K	CASSETTE HOLDER ASS'Y	
89	XTB3+6FFZ	SCREW		133	RMQ0430	RIVET	





MECHANISM PARTS LOCATION

• Top view

**Note:**  
When changing mechanism parts, apply the specified grease to areas marked "x x" as shown in the drawing.

Ref. No.	Part Name	Part No.
①	FLOIL AK-152	SZZ0L18
②	OIL #56	RZZ0L02
③	Molycoat EM-20L	RZZ0L05

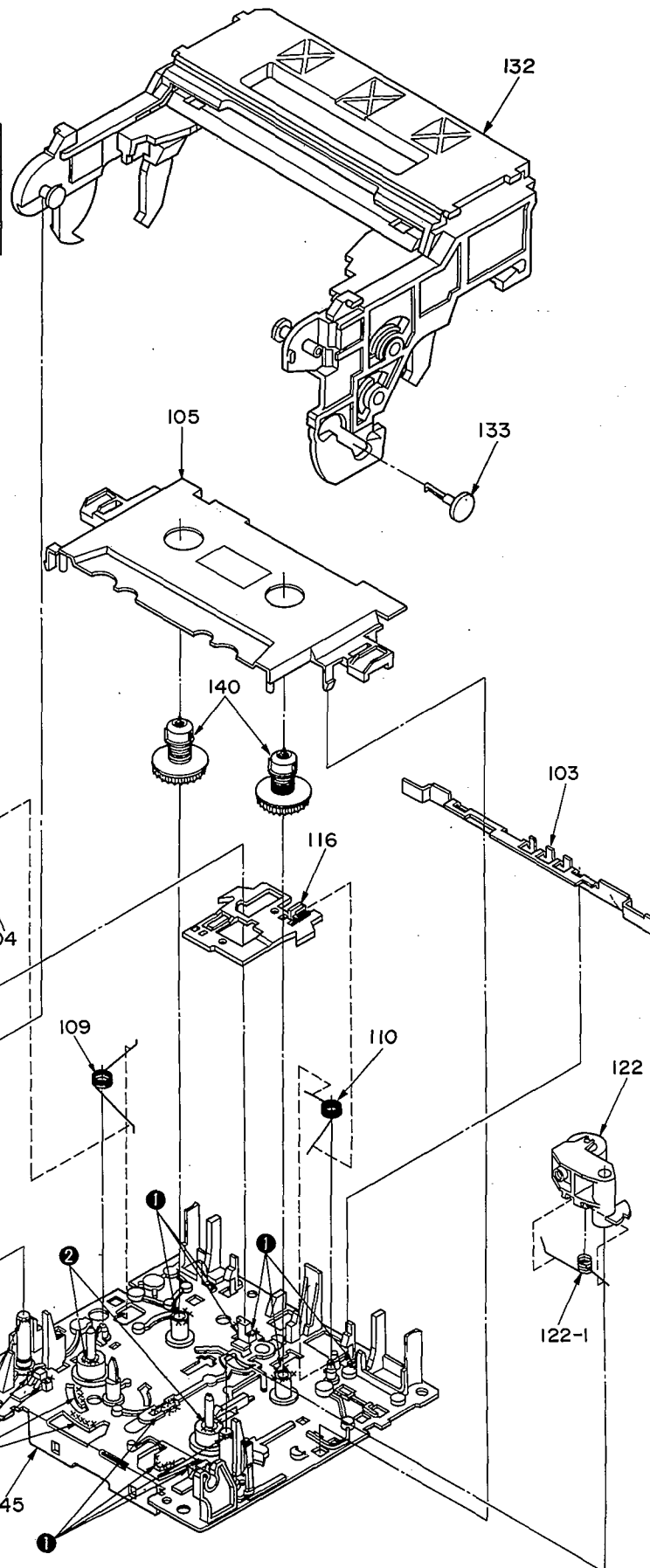

• Bottom view

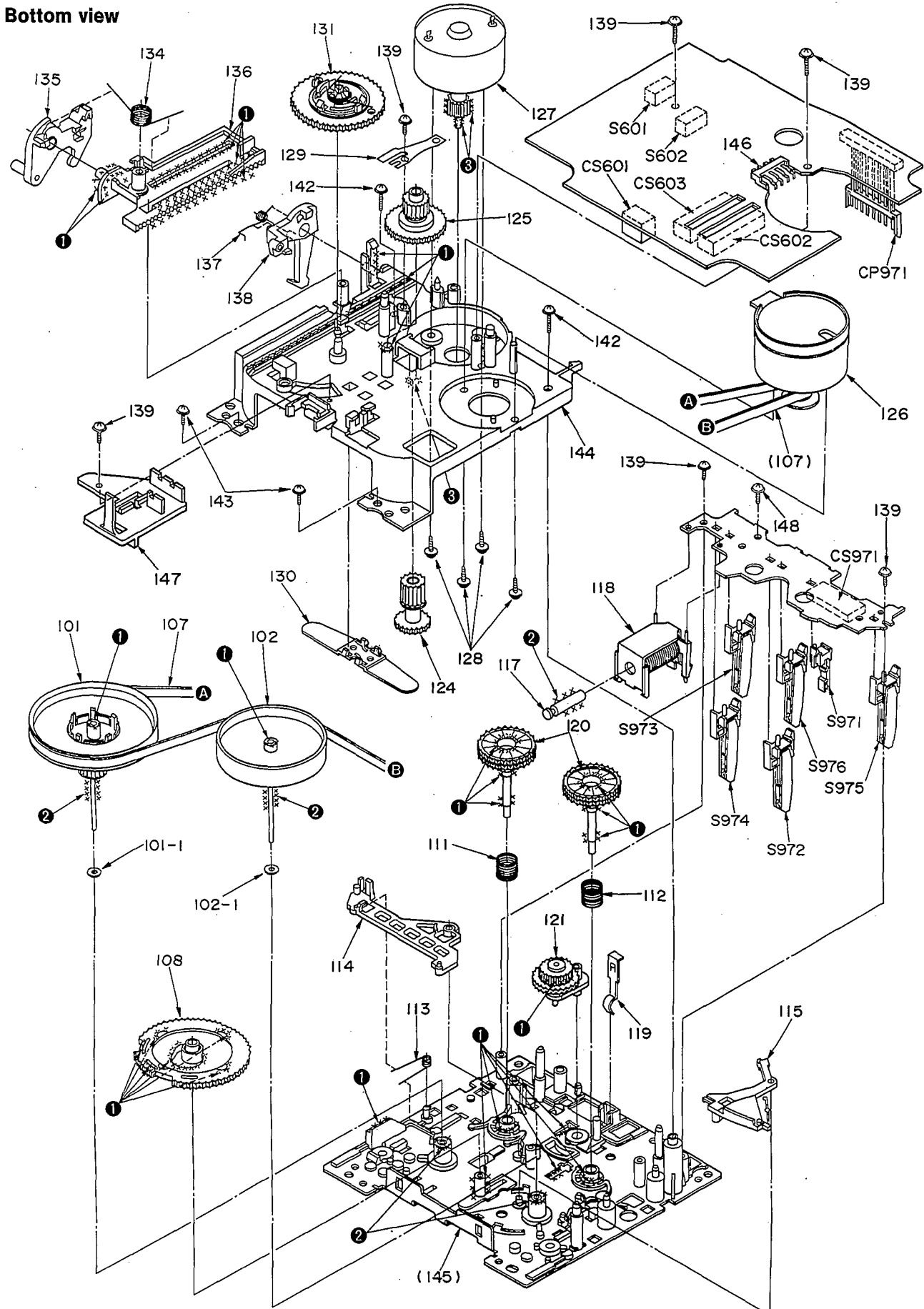

Ref. No.	Part No.	Part Name & Description	Remarks	Ref. No.	Part No.	Part Name & Description	Remarks
134	RMB0269	SPRING		142	XTW26+12S	SCREW	
135	RML0270A-1	DRIVE LEVER		143	XTW26+6L	SCREW	
136	RMQ0312A	DRIVE RACK		144	RFKJSCH404AK	SUB CHASSIS ASS'Y	
137	RMB0268	SPRING		145	RFKJSCH404BK	CHASSIS ASS'Y	
138	RML0271A	HOLDER HOOK		146	RJRO113	MOTOR CONNECTOR TER.	
139	XTW2+6S	SCREW		147	RMK0263	SHOULDER CHASSIS	
140	RXR0018	REEL LABEL UNIT		148	XYC2-JF16	SCREW	
141	XTW2+5L	SCREW					

## RESISTORS AND CAPACTORS

Notes : \* Capacity values are in microfarads ( $\mu\text{F}$ ) unless specified otherwise, P = Pico-farads (pF) F = Farads (F)  
 \* Resistance values are in ohms, unless specified otherwise, 1K = 1,000 (OHM), 1M = 1,000k (OHM)

Ref. No.	Part No.	Values & Remarks	Ref. No.	Part No.	Values & Remarks	Ref. No.	Part No.	Values & Remarks
			R132	ERDS2TJ103	1/4W 10K	R209	ERDS2TJ103	1/4W 10K
		RESISTORS	R133-137	ERDS2TJ102	1/4W 1K	R210	ERDS2TJ473	1/4W 47K
			R138	ERDS2TJ103	1/4W 10K	R210	ERDS2TJ272T	1/4W 2.7K
R103	ERDS2TJ330	1/4W 33	R139, 140	ERDS2TJ272T	1/4W 2.7K	R231, 232	ERDS2TJ222	1/4W 2.2K
R104	ERDS2TJ822	1/4W 8.2K	R141, 142	ERDS2TJ103	1/4W 10K	R233, 234	ERDS2TJ103	1/4W 10K
R105	ERDS2TJ471	1/4W 470	R143, 144	ERDS2TJ222	1/4W 2.2K	R236-244	ERDS2TJ103	1/4W 10K
R106	ERDS2TJ474	1/4W 470K	R145, 146	ERDS2TJ821	1/4W 820	R251	ERDS2TJ103	1/4W 10K
R107	ERDS2TJ331	1/4W 330	R147, 148	ERDS2TJ474	1/4W 470K	R252, 253	ERDS2TJ472	1/4W 4.7K
R108	ERDS2TJ474	1/4W 470K	R149	ERDS2TJ680T	1/4W 68	R254	ERDS2TJ562	1/4W 5.6K
R109	ERDS2TJ331	1/4W 330	R171, 172	ERDS2TJ102	1/4W 1K	R255	ERDS2TJ182	1/4W 1.8K
R110	ERDS2TJ102	1/4W 1K	R173	ERDS2TJ471	1/4W 470	R256	ERDS2TJ102	1/4W 1K
R112	ERDS2TJ104	1/4W 100K	R175	ERDS2TJ102	1/4W 1K	R257	ERDS2TJ471	1/4W 470
R113	ERDS2TJ103	1/4W 10K	R176	ERDS2TJ391	1/4W 390	R261	ERDS2TJ332	1/4W 3.3K
R114	ERDS2TJ562	1/4W 5.6K	R191	ERDS2TJ103	1/4W 10K	R262	ERDS2TJ824	1/4W 820K
R115	ERDS2TJ561	1/4W 560	R192	ERDS2TJ122	1/4W 1.2K	R264	ERDS2TJ682T	1/4W 6.8K
R116	ERDS2TJ102	1/4W 1K	R193	ERDS2TJ182	1/4W 1.8K	R265	ERDS2TJ472	1/4W 4.7K
R117	ERDS2TJ682T	1/4W 6.8K	R194	ERDS2TJ122	1/4W 1.2K	R271	ERDS2TJ152	1/4W 1.5K
R118	ERDS2TJ562	1/4W 5.6K	R195	ERDS2TJ222	1/4W 2.2K	R272	ERDS2TJ562	1/4W 5.6K
R119	ERDS2TJ822	1/4W 8.2K	R201	ERDS2TJ473	1/4W 47K	R273	ERDS2TJ272T	1/4W 2.7K
R120	ERDS2TJ473	1/4W 47K	R201	ERDS2TJ102	1/4W 1K	R274, 275	ERDS2TJ102	1/4W 1K
R121	ERDS2TJ332	1/4W 3.3K	R202	ERDS2TJ223	1/4W 22K	R276	ERDS2TJ105T	1/4W 1M
R122	ERDS2TJ272T	1/4W 2.7K	R202	ERDS2TJ272T	1/4W 2.7K	R277	ERDS2TJ334	1/4W 330K
R124	ERDS2TJ391	1/4W 390	R203	ERDS2TJ224T	1/4W 220K	R278	ERDS2TJ105T	1/4W 1M
R125, 126	ERDS2TJ472	1/4W 4.7K	R204, 205	ERDS2TJ473	1/4W 47K	R279	ERDS2TJ334	1/4W 330K
R127	ERDS2TJ103	1/4W 10K	R206	ERDS2TJ182	1/4W 1.8K	R280, 281	ERDS2TJ102	1/4W 1K
R128	ERDS2TJ820	1/4W 82	R207	ERDS2TJ473	1/4W 47K	R285, 286	ERDS2TJ273	1/4W 27K
R129	ERDS2TJ473	1/4W 47K	R208	ERDS2TJ272T	1/4W 2.7K	R287, 288	ERDS2TJ332	1/4W 3.3K
R130, 131	ERDS2TJ102	1/4W 1K	R207, 208	ERDS2TJ102	1/4W 1K	R289, 290	ERDS2TJ102	1/4W 1K

Ref. No.	Part No.	Values & Remarks	Ref. No.	Part No.	Values & Remarks	Ref. No.	Part No.	Values & Remarks
R299	ERDS2TJ102	1/4W 1K	R503, 504	ERDS2TJ222	1/4W 2.2K	R653, 654	ERDS2TJ333	1/4W 33K
R301	ERG1SJ101E	1W 100 $\Delta$	R505-508	ERDS2TJ563	1/4W 56K	R655	ERDS2TJ332	1/4W 3.3K
R400	ERDS2TJ332	1/4W 3.3K	R509	ERD25FJ470	1/4W 47 $\Delta$	R657, 658	ERDS2TJ272T	1/4W 2.7K
R401, 402	ERDS2TJ682T	1/4W 6.8K	R511	ERDS2TJ563	1/4W 56K	R660	ERDS2TJ272T	1/4W 2.7K
R403, 404	ERDS2TJ473	1/4W 47K	R512	ERDS2TJ103	1/4W 10K	R661, 662	ERDS2TJ102	1/4W 1K
R405, 406	ERDS2TJ472	1/4W 4.7K	R513, 514	ERDS2TJ102	1/4W 1K	R663	ERDS2TJ122	1/4W 1.2K
R407-410	ERDS2TJ223	1/4W 22K	R515, 516	ERDS1FVJ100T	1/2W 10 $\Delta$	R664	ERDS2TJ182	1/4W 1.8K
R411, 412	ERDS2TJ333	1/4W 33K	R517	ERDS2TJ823T	1/4W 82K	R665	ERDS2TJ222	1/4W 2.2K
R413, 414	ERDS2TJ273	1/4W 27K	R518	ERDS2TJ124T	1/4W 120K	R666	ERDS2TJ272T	1/4W 2.7K
R415, 416	ERDS2TJ223	1/4W 22K	R519	ERDS2TJ563	1/4W 56K	R667	ERDS2TJ472	1/4W 4.7K
R417-419	ERDS2TJ393	1/4W 39K	R523, 524	ERDS2TJ122	1/4W 1.2K	R668	ERDS2TJ682T	1/4W 6.8K
R420	ERDS2TJ472	1/4W 4.7K	R531-534	ERDS2TJ181T	1/4W 180	R669	ERDS2TJ103	1/4W 10K
R421, 422	ERDS2TJ223	1/4W 22K	R575	ERDS2TJ564	1/4W 560K	R671, 672	ERDS2TJ102	1/4W 1K
R423-426	ERDS2TJ103	1/4W 10K	R576	ERDS2TJ103	1/4W 10K	R673	ERDS2TJ122	1/4W 1.2K
R427, 428	ERDS2TJ153	1/4W 15K	R603	ERDS2TJ473	1/4W 47K	R674	ERDS2TJ182	1/4W 1.8K
R429, 430	ERDS2TJ472	1/4W 4.7K	R604	ERDS2TJ102	1/4W 1K	R675	ERDS2TJ222	1/4W 2.2K
R431, 432	ERDS2TJ103	1/4W 10K	R605	ERDS2TJ222	1/4W 2.2K	R676	ERDS2TJ272T	1/4W 2.7K
R433	ERDS2TJ561	1/4W 560	R606	ERDS2TJ470	1/4W 47	R677	ERDS2TJ472	1/4W 4.7K
R434	ERDS2EJ121	1/4W 120	R607	ERDS2TJ224T	1/4W 220K	R678, 679	ERDS2TJ103	1/4W 10K
R435	ERDS2TJ334	1/4W 330K	R608	ERDS2TJ331	1/4W 330	R681, 682	ERDS2TJ561	1/4W 560
R436	ERDS2TJ105T	1/4W 1M	R609	ERDS2TJ103	1/4W 10K	R683	ERDS2TJ102	1/4W 1K
R437-440	ERDS2TJ472	1/4W 4.7K	R610	ERDS2TJ104	1/4W 100K	R684	ERDS2TJ391	1/4W 390
R441, 442	ERDS2TJ103	1/4W 10K	R612	ERDS2TJ224T	1/4W 220K	R685, 686	ERDS2TJ102	1/4W 1K
R445, 446	ERDS2TJ472	1/4W 4.7K	R613, 614	ERDS2TJ102	1/4W 1K	R687	ERDS2TJ473	1/4W 47K
R447, 448	ERDS2TJ123	1/4W 12K	R615	ERDS2TJ223	1/4W 22K	R688, 689	ERDS2TJ152	1/4W 1.5K
R449, 450	ERDS2TJ333	1/4W 33K	R616	ERDS2TJ103	1/4W 10K	R690	ERDS2TJ102	1/4W 1K
R453	ERG1SJ121E	1W 120 $\Delta$	R618	ERDS2TJ101	1/4W 100	R699	ERDS2TJ102	1/4W 1K
R455	ERDS2TJ272T	1/4W 2.7K	R620	ERDS2TJ101	1/4W 100	R701	ERDS2TJ102	1/4W 1K
R457	ERDS2TJ272T	1/4W 2.7K	R621	ERDS2TJ222	1/4W 2.2K	R701A	ERDS2TJ2R2T	1/4W 2.2
R460	ERDS2TJ105T	1/4W 1M	R622, 623	ERDS2TJ104	1/4W 100K	R702	ERQ16NKW1ROE	1/6W 1.0 $\Delta$
R461, 462	ERDS2TJ472	1/4W 4.7K	R624	ERDS2TJ103	1/4W 10K	R705, 706	ERDS2TJ472	1/4W 4.7K
R463, 464	ERDS2TJ152	1/4W 1.5K	R625	ERDS2TJ102	1/4W 1K	R707	ERDS1FVJ2R2T	1/2W 2.2 $\Delta$
R465	ERDS2TJ102	1/4W 1K	R626	ERDS2TJ472	1/4W 4.7K	R708	ERG1SJ331E	1W 330
R466	ERDS2TJ105T	1/4W 1M	R627-629	ERDS2TJ101	1/4W 100	R713	ERDS2TJ153	1/4W 15K
R467	ERDS2TJ474	1/4W 470K	R630	ERDS2TJ393	1/4W 39K	R714	ERD2FCVJ4R7T	1/4W 4.7 $\Delta$
R468	ERDS2TJ102	1/4W 1K	R631	ERDS2TJ102	1/4W 1K	R715	ERDS2TJ152	1/4W 1.5K
R469	ERDS2TJ334	1/4W 330K	R632	ERDS2TJ822	1/4W 8.2K	R716	ERDS2TJ560T	1/4W 56
R470	ERDS2TJ392T	1/4W 3.9K	R633	ERDS2TJ472	1/4W 4.7K	R718	ERDS2TJ152	1/4W 1.5K
R471, 472	ERDS2EJ121	1/4W 120	R634	ERDS2TJ682T	1/4W 6.8K	R719	ERDS2EJ121	1/4W 120
R473	ERDS2TJ105T	1/4W 1M	R635	ERDS2TJ103	1/4W 10K	R720	ERD2FCVJ4R7T	1/4W 4.7 $\Delta$
R474	ERDS2TJ104	1/4W 100K	R636	ERDS2TJ223	1/4W 22K	R722	ERDS2TJ681	1/4W 680
R475	ERDS2TJ222	1/4W 2.2K	R637	ERDS2TJ683	1/4W 68K	R724	ERDS2TJ221	1/4W 220
R476	ERDS2TJ473	1/4W 47K	R638, 639	ERDS2TJ103	1/4W 10K	R726	ERDS2TJ332	1/4W 3.3K
R477	ERDS2TJ223	1/4W 22K	R640	ERDS2TJ393	1/4W 39K	R727	ERDS1FVJ271T	1/2W 270 $\Delta$
R479, 480	ERDS2TJ333	1/4W 33K	R641, 642	ERDS2TJ103	1/4W 10K	R728, 729	ERDS2TJ152	1/4W 1.5K
R481, 482	ERDS2TJ822	1/4W 8.2K	R643	ERDS2TJ330	1/4W 33	R730	ERDS2TJ331	1/4W 330
R485, 486	ERDS2TJ683	1/4W 68K	R644	ERDS2TJ181T	1/4W 180	R733	ERDS2TJ102	1/4W 1K
R487, 488	ERDS2TJ472	1/4W 4.7K	R646	ERDS2TJ221	1/4W 220	R734	ERDS2TJ101	1/4W 100
R489, 490	ERDS2TJ104	1/4W 100K	R647	ERDS2TJ391	1/4W 390	R737, 738	ERDS2TJ101	1/4W 100
R491, 492	ERDS2TJ182	1/4W 1.8K	R648	ERDS2TJ331	1/4W 330	R753	ERDS2TJ103	1/4W 10K
R497, 498	ERDS2TJ333	1/4W 33K	R649	ERDS2TJ390	1/4W 39	R755	ERDS2TJ561	1/4W 560
R501, 502	ERDS2TJ104	1/4W 100K	R651, 652	ERDS2TJ103	1/4W 10K	R757, 758	ERDS2TJ103	1/4W 10K

Ref. No.	Part No.	Values & Remarks	Ref. No.	Part No.	Values & Remarks	Ref. No.	Part No.	Values & Remarks
R803	ERDS2TJ102	1/4W 1K	C137, 138	ECBT1H271KB5	50V 270P	C409	ECBT1H330J5	50V 33P
R804	ERDS2TJ103	1/4W 10K	C139, 140	ECFRIE822KR	25V 8200P	C410	ECBT1H100JC5	50V 10P
R805	ERDS2TJ222	1/4W 2.2K	C141-144	ECEA1HKA010B	50V 1U	C411, 412	ECBT1E103ZF	25V 0.01U
R808, 809	ERDS2TJ272T	1/4W 2.7K	C145	ECBT1H220JC5	50V 22P	C413	ECQV1H823JM3	50V 0.082U
R810	ERDS2TJ223	1/4W 22K	C146	ECBT1H331KB5	50V 330P	C414	ECBT0J223NS5	6.3V 0.022U
R811	ERDS2TJ272T	1/4W 2.7K	C147	ECBT1H102KB5	50V 1000P	C415, 416	ECBT1H270J5	50V 27P
R812	ERDS2TJ102	1/4W 1K	C148	ECBT1C103NS5	16V 0.01U	C417, 418	ECEA1HKA2R2B	50V 2.2U
R813	ERDS2TJ272T	1/4W 2.7K	C149	ECBT1H104ZF5	50V 0.1U	C419, 420	ECEA1CKA100B	16V 10U
R815, 816	ERDS2TJ103	1/4W 10K	C171	ECBT1C103NS5	16V 0.01U	C421, 422	ECBT1C332KR5	16V 3300P
R841, 842	ERDS2TJ223	1/4W 22K	C172	ECBT1H331KB5	50V 330P	C423, 424	ECQV1H823JM3	50V 0.082U
R843	ERDS2TJ102	1/4W 1K	C173	ECEA1CKA220B	16V 22U	C425, 426	ECQV1H473JM3	50V 0.047U
R844	ERDS2TJ222	1/4W 2.2K	C174	ECEA1CKA101B	16V 100U	C427-430	ECEA1CKA100B	16V 10U
R851, 852	ERDS2TJ822	1/4W 8.2K	C181	ECBT1H471KB5	50V 470P	C431, 432	ECBT1E103ZF	25V 0.01U
R853, 854	ERDS2TJ103	1/4W 10K	C201	ECBT1E223ZF	25V 0.022U	C435, 436	ECEA1HKA010B	50V 1U
R855, 856	ERDS2TJ682T	1/4W 6.8K	C201	ECEA1CKA100B	16V 10U	C437, 438	ECBT1H101KB5	50V 100P
R857, 858	ERDS2TJ333	1/4W 33K	C202	ECBT1H104ZF5	50V 0.1U	C441, 442	ECEA1HKA2R2B	50V 0.22U
R861, 862	ERDS2TJ821	1/4W 820	C203	ECEA1HKA4R7B	50V 4.7U	C443, 444	ECBT1H101KB5	50V 100P
R971	ERDS2TJ221T	1/4W 220	C211	ECEA1CKA100B	16V 10U	C445, 446	ECEA1HKA2R2B	50V 2.2U
R973	ERDS2TJ393T	1/4W 39K	C212	ECBT1H104ZF5	50V 0.1U	C447	ECEA1EKA4R7B	25V 4.7U
R974	ERDS2TJ393T	1/4W 39K	C213	ECBT1C103NS5	16V 0.01U	C448, 449	ECEA1CKA100B	16V 10U
			C214, 215	ECEA1EKA4R7B	25V 4.7U	C450	ECEA1AKA101B	10V 100U
		CAPACITORS	C231, 232	ECBT1H470J5	50V 47P	C451, 452	ECEA1HKA68B	50V 0.68U
			C233	ECBT1H104ZF5	50V 0.1U	C455	ECEA1EKA4R7B	25V 4.7U
C100	ECBT1E103ZF	25V 0.01U	C234	ECBT1H102KB5	50V 1000P	C456	ECEA1EKA100B	25V 10U
C101	ECBT1C103NS5	16V 0.01U	C251	ECEA1HKA2R2B	50V 2.2U	C459, 460	ECEA1CKA100B	16V 10U
C103	ECBT1C103NS5	16V 0.01U	C252	ECBT1E103ZF	25V 0.01U	C461, 462	ECBT1H101KB5	50V 100P
C104, 105	ECBT1H102KB5	50V 1000P	C253-256	ECBT1H101KB5	50V 100P	C463, 464	ECBT1H270J5	50V 27P
C106	ECBT1C103NS5	16V 0.01U	C257	ECEA1EKA4R7B	25V 4.7U	C469, 470	ECBT1E103ZF	25V 0.01U
C107	ECBT1H473ZF5	50V 0.047U	C258	ECBT1H102KB5	50V 1000P	C471, 472	ECEA1HKA010B	50V 1U
C108	ECBT1H100JC5	50V 10P	C259	ECBT1E103ZF	25V 0.01U	C481	ECBT1H330J5	50V 33P
C109, 110	ECBT1C103NS5	16V 0.01U	C260	ECEA1HKA2R2B	50V 2.2U	C482, 483	ECBT1H120JC5	50V 12P
C111	ECEA1EKA4R7B	25V 4.7U	C261	ECBT1E223ZF	25V 0.022U	C490	ECEA1HKA010B	50V 1U
C112	ECBT1C103NS5	16V 0.01U	C262	ECEA1CKA220B	16V 22U	C491, 492	ECEA1HKA68B	50V 0.68U
C113	ECBT1H102KB5	50V 1000P	C263	ECQV1H823JM3	50V 0.082U	C501, 502	ECEA1HKA2R2B	50V 2.2U
C114	ECEA1HKA3R3B	50V 3.3U	C264	ECQV1H104JM3	50V 0.1U	C503, 504	ECEA1CKA100B	16V 10U
C115	ECEA1CKA100B	16V 10U	C265	ECBT1C222KR5	16V 2200P	C505, 506	ECBT1H102KB5	50V 1000P
C116	ECBT1C822MS5	16V 8200P	C266, 267	ECQB1H223JF3	50V 0.022U	C507, 508	ECBT1H150JC5	50V 15P
C117	ECQP2A221JZT	100V 220P	C268	ECEA1HKA010B	50V 1U	C509, 510	ECBT1H331KB5	50V 330P
C118, 119	ECFRIE103KR	25V 0.01U	C269, 270	ECEA1EKA4R7B	25V 4.7U	C512	ECEA0JKA470B	6.3V 47U
C120, 121	ECEA1HKA010B	50V 1U	C271	ECEA1CKA100B	16V 10U	C513	ECEA1CKA100B	16V 10U
C122	ECEA1HKA2R2B	50V 2.2U	C285	ECBT1H101KB5	50V 100P	C515, 516	ECBT1H104ZF5	50V 0.1U
C123	ECEA1HKA010B	50V 1U	C286	ECBT1E103ZF	25V 0.01U	C517	ECEA0JKA101B	6.3V 100U
C124	ECBT1H102KB5	50V 1000P	C287, 288	ECBT1H101KB5	50V 100P	C523, 524	ECBT1C472KR5	16V 4700P
C125	ECBT1H150JC5	50V 15P	C290	ECBT1H101KB5	50V 100P	C531, 532	ECBT1E223ZF	25V 0.022U
C126	ECBT1H473ZF5	50V 0.047U	C291	ECBT1E103ZF	25V 0.01U	C533, 534	ECBT1E223ZF	25V 0.022U
C127	ECEA1CKA220B	16V 22U	C299	ECBT1H470J5	50V 47P	C535, 536	ECBT1H102KB5	50V 1000P
C128	ECBT1C103NS5	16V 0.01U	C301	ECEA1CKA101B	16V 100U	C601, 602	ECBT1H104ZF5	50V 0.1U
C129, 130	ECEA0JKA101B	6.3V 100U	C401 403	ECBT1H101KB5	50V 100P	C604	ECBT1C103NS5	16V 0.01U
C131	ECBT1C103NS5	16V 0.01U	C404	ECBT1H330J5	50V 33P	C605	ECEA1HKA2R2B	50V 2.2U
C132	ECBT1H102KB5	50V 1000P	C405	ECEA1CKA100B	16V 10U	C606	ECEA0JH102	6.3V 1000U
C133, 134	ECBT1H270J5	50V 27P	C406	ECBT1E103ZF	25V 0.01U	C607	ECEA1AKA330B	10V 33U
C135, 136	ECBT1C822MS5	16V 8200P	C407, 408	ECEA1HKA2R2B	50V 2.2U	C608	ECEA1CKA100B	16V 10U

Ref. No.	Part No.	Values & Remarks	Ref. No.	Part No.	Values & Remarks	Ref. No.	Part No.	Values & Remarks
C609, 610	ECBT1H104ZF5	50V 0.1U	R103	ERJ6GEYJ124V	1/10W 120K	C2	ECUV1C104ZFN	16V 0.1U
C611	ECBT1H200JC5	50V 20P	R104	ERJ6GEYJ104V	1/10W 100K	C101	ECUV1C333KBN	16V 0.033U
C612	ECBT1H220JC5	50V 22P	R105	ERJ6GEYJ221V	1/10W 220	C102, 103	ECUV1C104KBN	16V 0.1U
C613	ECBT1C103NS5	16V 0.01U	R106	ERJ6GEYJ330V	1/10W 33	C104	ECUV1E183KBN	25V 0.018U
C614	ECEA1HKA010B	50V 1U	R107	ERJ6GEYJ125V	1/10W 1.2M	C105	ECUV1C104ZFN	16V 0.1U
C615	ECEA1EKA100B	25V 10U	R108	ERJ6GEYJ124V	1/10W 120K	C106, 107	ECUV1H331KBN	50V 330P
C616	ECEA1VKA4R7B	35V 4.7U	R109	ERJ6GEYJ333V	1/10W 33K	C108, 109	ECUV1C333KBN	16V 0.033U
C617	ECBT1H102KB5	50V 1000P	R110	ERJ6GEYJ102V	1/10W 1K	C110	ECUV1E103KBN	25V 0.01U
C625	ECBT1H821KB5	50V 820P	R111	ERJ6GEYJ912V	1/10W 9.1K	C111	ECUV1C473KBN	16V 0.047U
C626	ECBT1H101KB5	50V 100P	R112	ERJ6GEYJ102V	1/10W 1K	C112	ECUV1E223KBN	25V 0.022U
C651, 652	ECBT1H330J5	50V 33P	R113	ERJ6GEYJ912V	1/10W 9.1K	C113	ECUV1C333KBN	16V 0.033U
C653	ECBT1H104ZF5	50V 0.1U	R114	ERJ6GEYJ153V	1/10W 15K	C114	ECUV1H222KBN	50V 2200P
C661	ECBT1H102KB5	50V 1000P	R115	ERJ6GEYJ333V	1/10W 33K	C115	ECUV1H152KBN	50V 1500P
C662	ECBT1C103NS5	16V 0.01U	R116, 117	ERJ6GEYJ223V	1/10W 22K	C116	ECUV1E104ZFM	25V 0.1U
C681	ECBT1C103NS5	16V 0.01U	R118	ERJ6GEYJ683V	1/10W 68K	C202	ECEA1AKA220I	10V 22U
C686	ECBT1H102KB5	50V 1000P	R204	ERJ6GEYJ100	1/10W 10	C311	ECUV1C104ZFN	16V 0.1U
C691	ECBT1C103NS5	16V 0.01U	R206	ERJ6GEYJ223V	1/10W 22K	C312	ECUV1E103KBN	25V 0.01U
C701-703	ECA1VM472B	35V 4700U $\Delta$	R301	ERJ6GEYJ103V	1/10W 10K	C401	ECEAOJKA331I	6.3V 330U
C701	ECEA1AKA330B	10V 33U	R302, 303	ERJ6GEYJ102V	1/10W 1K	C402, 403	ECUV1C104ZFN	16V 0.1U
C704	ECKR1H103ZF5	50V 0.01U	R308	ERJ6GEYJ473V	1/10W 47K	C501	ECUV1H561KBN	50V 560P
C706	ECQE1104KF3	100V 0.1U	R311	ERJ6GEYJ104V	1/10W 100K	C502	ECUV1C104KBN	16V 0.1U
C708	ECA1HM470B	50V 47U	R312	ERJ6GEYJ103V	1/10W 10K	C503	ECUV1E223KBN	25V 0.022U
C710, 711	ECKR1H103ZF5	50V 0.01U	R401	ERJ6GEYJ392V	1/10W 3.9K	C504	ECUV1C474KBM	16V 0.47U
C713	ECA1HM470B	50V 47U $\Delta$	R402	ERJ6GEYJ123V	1/10W 12K	C505	ECEAOJKA101I	6.3V 100U
C714	ECKR1H103ZF5	50V 0.01U	R403	ERJ6GEYJ154V	1/10W 150K	C506, 507	ECUV1H390KCN	50V 39P
C719	ECKR1H103ZF5	50V 0.01U	R404	ERJ6GEYJ822V	1/10W 8.2K	C508	ECUV1C104ZFN	16V 0.1U
C720, 721	ECEA1CKA101B	16V 100U	R405	ERJ6GEYJ272V	1/10W 2.7K	C509	ECUV1H390KCM	50V 39P
C722	ECKR1H103ZF5	50V 0.01U	R406	ERJ6GEYJ393V	1/10W 39K	C601	ECUV1C104ZFN	16V 0.1U
C723	ECEA1EKA220B	25V 22U	R407	ERJ6GEYJ272V	1/10W 2.7K	C602	ECEAOJKA470I	6.3V 47U
C724	ECEA1HKA010B	50V 1U	R408	ERJ6GEYJ683V	1/10W 68K	C603, 604	ECUV1H332KBN	50V 3300P
C726	ECEA1EKA4R7B	25V 4.7U	R409	ERJ6GEYJ224V	1/10W 220K	C605	ECEA1AKA220I	10V 22U
C727	ECEAOJKA101B	6.3V 100U	R501	ERJ6GEYJ681V	1/10W 680	C606	ECUV1C104ZFN	16V 0.1U
C729	ECEA1CKA101B	16V 100U	R502	ERJ6GEYJ103V	1/10W 10K	C607, 608	ECEA1CPK100I	16V 10U
C730	ECBT1E103ZF	25V 0.01U	R503	ERJ6GEYJ823	1/10W 82K	C609	ECUV1C104ZFN	16V 0.1U
C731	ECEA1CKA100B	16V 10U	R504	ERJ6GEYJ683V	1/10W 68K			
C732	ECBT1E103ZF	25V 0.01U	R505	ERJ6GEYJ471V	1/10W 470			<MECHANISM CONT. P. C. B. >
C733	ECEA1AKA101B	10V 100U	R506	ERJ6GEYJ100	1/10W 10			RESISTORS
C736	ECBT1E223ZF	25V 0.022U	R507	ERJ6GEYJ822V	1/10W 8.2K			
C737	ECEA1CKA101B	16V 100U	R601, 602	ERJ6GEYJ221V	1/10W 220	R601, 602	ERJ6GEYJ820V	1/10W 82
C739, 740	ECBT1H104ZF5	50V 0.1U	R603	ERJ6GEYJ682V	1/10W 6.8K	R603, 604	ERJ6GEYJ472V	1/10W 4.7K
C803	ECBT1H104ZF5	50V 0.1U	R604	ERJ6GEYJ104V	1/10W 100K	R605, 606	ERJ6GEYJ223V	1/10W 22K
C804, 805	ECBT1H120JC5	50V 12P	R605	ERJ6GEYJ392V	1/10W 3.9K	R607, 608	ERJ6GEYJ562V	1/10W 5.6K
C812	RCE1AM471BV	10V 470P	R606	ERJ6GEYJ222V	1/10W 2.2K	R609, 610	ERJ6GEYJ103V	1/10W 10K
C841, 842	ECEA1HKA010B	50V 1U				R613, 614	ERJ6GEYJ682V	1/10W 6.8K
C843	ECEA1EKA4R7B	25V 4.7U			CHIP JUMPERS	R615, 616	ERJ6GEYJ104V	1/10W 100K
C845, 846	ECEA1EKA4R7B	25V 4.7U				R621	ERJ6GEYJ334V	1/10W 330K
C851, 852	ECBT1H271KB5	50V 270P	RJ1-7	ERJ6GEYOR00V	CHIP JUMPER	R622	ERJ6GEYJ273V	1/10W 27K
			RJ11, 12	ERJ6GEYOR00V	CHIP JUMPER	R623	ERDS2TJ103	1/4W 10K
		<SERVO P. C. B. >				R624	ERJ6GEYJ123V	1/10W 12K
		RESISTORS			CAPACITORS	R625	ERJ6GEYJ105	1/10W 1M
						R626	ERJ6GEYJ102V	1/10W 1K
R101, 102	ERJ6GEYJ223V	1/10W 22K	C1	ECEAOJKA331I	6.3V 330U	R627	ERJ6GEYJ105	1/10W 1M

Ref. No.	Part No.	Values & Remarks	Ref. No.	Part No.	Values & Remarks
R631	ERJ6GEYJ103V	1/10W 10K	C609, 610	ECUV1H681KBN	50V 680P
R632	ERJ6GEYJ273V	1/10W 27K	C611, 612	ECST0JY475RR	6.3V 4.7U
R633	ERJ8GEYJ183V	1/8W 18K	C615, 616	ECUV1H331KBN	50V 330P
R634	ERDS2TJ472	1/4W 4.7K	C617, 618	ECEA1HKS2R2I	50V 2.2U
R635, 636	ERJ6GEYJ103V	1/10W 10K	C619, 620	ECEA1HKS010	50V 1U
R639, 640	ERJ6GEYJ272V	1/10W 2.7K	C621, 622	ECST1CY105RR	16V 1U
R641, 642	ERJ6GEYJ273V	1/10W 27K	C625	ECEA1EKA4R7I	25V 4.7U
R643	ERDS2TJ472	1/4W 4.7K	C626	ECEA1EKS4R7I	25V 4.7U
R644, 645	ERJ6GEYJ152V	1/10W 1.5K	C627, 628	ECEA1HKA010I	50V 1U
R646	ERJ6GEYJ334V	1/10W 330K	C629, 630	ECUV1H102KBN	50V 1000P
R648	ERJ6GEYJ103V	1/10W 10K	C633	ECUV1E223MBN	25V 0.022U
R649	ERJ6GEYJ182V	1/10W 1.8K	C634, 635	ECEA1AKA101I	10V 100U
R650	ERJ6GEYJ682V	1/10W 6.8K	C636	ECUV1H472KBN	50V 4700P
R651	ERJ6GEYJ223V	1/10W 22K	C637	ECEA0JKS470	6.3V 47U
R652	ERJ6GEYJ153V	1/10W 15K	C638	ECEA0JKA470I	6.3V 47U
R653	ERJ6GEYJ182V	1/10W 1.8K	C640	ECEA1CKA100I	16V 10U
R654	ERJ6GEYJ223V	1/10W 22K	C641, 642	ECUV1C104KBN	16V 0.1U
R655	ERDS1FVJ2R2T	1/2W 2.2 $\Delta$	C643	ECUV1E104MBN	25V 0.1U
R656-658	ERJ6GEYJ472V	1/10W 4.7K	C644	ECEA2AN2R2SI	100V 2.2U
R659, 660	ERJ6GEYJ223V	1/10W 22K	C647	ECQP2A821JZT	100V 820P
R661	ERJ6GEYJ105	1/10W 1M	C648	ECQP2E472JZT	250V 4700P
R662	ERJ6GEYJ223V	1/10W 22K	C650	ECEA1AKA101I	10V 100U
R663	ERJ6GEYJ104V	1/10W 100K	C651	ECUV1E103MBN	25V 0.01U
R664	ERJ6GEYJ153V	1/10W 15K	C652	ECEA1HKA0R1I	50V 0.1U
R665	ERJ6GEYJ393V	1/10W 39K	C653	ECQB1H393JF3	50V 0.039U
R666, 667	ERJ6GEYJ273V	1/10W 27K	C654	ECUV1H102KBN	50V 1000P
R671	ERDS2TJ103	1/4W 10K	C655	ECUV1H332KBN	50V 3300P
R673	ERJ6GEYJ222V	1/10W 2.2K	C656	ECUV1H102KBN	50V 1000P
R674	ERJ6GEYJ472V	1/10W 4.7K	C657, 658	ECUV1E103MBN	25V 0.01U
R675	ERJ8GEYJ104V	1/8W 100K	C659	ECEA0JKA470I	6.3V 47U
R676	ERDS2TJ104	1/4W 100K	C660	ECUV1C104KBN	16V 0.1U
R677	ERJ6GEYJ104V	1/10W 100K	C661	ECEA1CKA101	16V 100U
R678	ERJ8GEYJ472V	1/8W 4.7K	C662	ECUV1E103MBN	25V 0.01U
R679	ERDS2TJ470	1/4W 47	C663	ECUV1E104ZFN	25V 0.1U
R680	ERJ6GEYK1R8V	1/10W 1.8	C664	ECEA1AKA101I	10V 100U
R681	ERJ8GEYK1R8V	1/8W 1.8	C665	ECUV1E104ZFN	25V 0.1U
R682	ERJ6GEYJ222V	1/10W 2.2K	C666-668	ECUV1H102KBN	50V 1000P
R683	ERJ6GEYJ103V	1/10W 10K	C669	ECEA0JKA470I	6.3V 47U
R684	ERJ6GEYJ102V	1/10W 1K	C670-672	ECUV1H471KBN	50V 470P
R685, 686	ERJ6GEYJ471V	1/10W 470			
R687-689	ERJ6GEYJ222V	1/10W 2.2K			
		CHIP JUMPERS			
RJ699	ERJ8GEYOR00V	CHIP JUMPER			
		CAPACITORS			
C601, 602	ECUV1H331KBN	50V 330P			
C603, 604	ECEA0JKA470I	6.3V 47U			
C605, 606	ECUV1E183KBN	25V 0.018U			
C607, 608	ECST1AY475RR	10V 4.7U			

1037

## REPLACEMENT PARTS LIST

**Notes:** \*Important safety notice:

 Components identified by  $\Delta$  mark have special characteristics important for safety.

Furthermore, special parts which have purposes of fire-retardant (resistors), high-quality sound (capacitors), low-noise (resistors), etc. are used.

When replacing any of components, be sure to use only manufacturer's specified parts shown in the parts list.

\*The parenthesized indications in the Remarks columns specify the areas. (Refer to the cover page for area.)

Parts without these indications can be used for all areas.

\*Remote Control Ass'y: Supply period for three years from termination of production.

\*The "(SF)" mark denotes the standard part.

Ref. No.	Part No.	Part Name & Description	Remarks	Ref. No.	Part No.	Part Name & Description	Remarks
		PACKING MATERIAL		A1	RFKSALS10EI	INSTRUCTION MANUAL ASS'Y	(EI)
				A2	RQA0013	WARRANTY CARD	
				A3	RQC80169	SERVICENTER LIST	
P1	RPG2203	PACKING CASE	(EB)	A4	EUR642521	REMOTE CONTROL TRANSMITTER	
P1	RPG2202	PACKING CASE	(EG, EI)	A4-1	UR64FT1549B	SLIDE COVER (BATTERY COVER)	FOR R/C TRANSMITTER
P2	RPN0847	CUSHION		A5	RJA0019-2K	AC POWER SUPPLY CORD	(EG, EI) $\Delta$ (SF)
P3	RPQF0141	ACCESSORIES BOX		A5	VJA0733	AC POWER SUPPLY CORD	(EB) $\Delta$ (SF)
P4	XZB25X34C03Y	PROTECTION BAG (F. B.)		A6	RSA0007	FM INDOOR ANTENNA	
P5	XZB70X85A01Z	PROTECTION BAG (UNIT)		A7	RSA0010	AM LOOP ANTENNA SET	
		ACCESSORIES		A7-1	RMN0244	AM ANTENNA HOLDER	
				A7-2	XTN3+10AFZ	SCREW	
A1	RQT2653-B	INSTRUCTION MANUAL	(EB)	A8	SJP9009	ATTACHMENT PLUG	(EB) $\Delta$
A1	RFRSALS10EG	INSTRUCTION MANUAL ASS'Y	(EG)	A9	REED499	SPEAKER CORD	

## PACKAGING

