

Service Manual

Receiver

AV Control Stereo Receiver

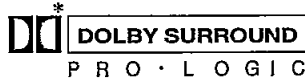

SA-TX30

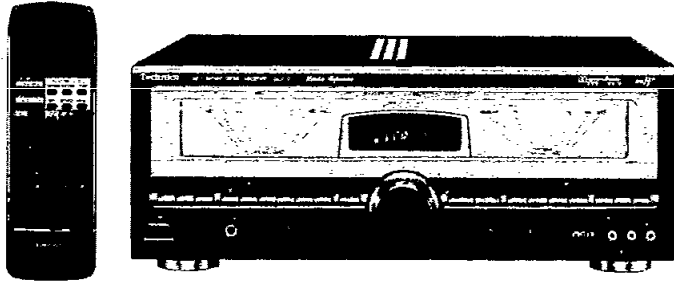

Colour (K) ... Black Type

Areas

E Europe.
 EB Great Britain.
 EG Germany and Italy.

* Manufactured under license from Dolby Laboratories Licensing Corporation. Additionally licensed under one or more of the following patents: U.S. numbers 3,632,886, 3,7,56,792 and 3,959,590; Canada numbers 1,004,603 and 1,037,877.

"Dolby" and the double-D symbol are trademarks of Dolby Laboratories Licensing Corporation.

Please file and use this manual together with the service manual for Model No. SA-TX50, Order No. AD9607155C8.

- Notes:**
- This simplified service manual is provided to indicate the main differences between the original model No. SA-TX50 (E) and the subsequent model No. SA-TX30 (E, EB, EG).
 - Refer to the Specifications, Schematic Diagram, Printed Circuit Board Diagram, Replacement Parts List, Cabinet Parts Location and Packaging of this service manual.

⚠ WARNING

This service information is designed for experienced repair technicians only and is not designed for use by the general public. It does not contain warnings or cautions to advise non-technical individuals of potential dangers in attempting to service a product. Products powered by electricity should be serviced or repaired only by experienced professional technicians. Any attempt to service or repair the product or products dealt with in this service information by anyone else could result in serious injury or death.

Technics®

© 1997 Matsushita Electric Industrial Co., Ltd.
 All rights reserved. Unauthorized copying and distribution is a violation of law.

CHANGES

Specifications (DIN 45 500) (SA-TX50 Service Manual of cover page.)

■ POWER AMPLIFIER SECTION

1 kHz continuous power output both channels driven
1.0% total harmonic distortion
70 W per channel (6 Ω)

Total harmonic distortion
rated power at 20 Hz-20 kHz 0.1% (4 Ω)
half power at 1 kHz 0.03% (8 Ω)

Power output at the Dolby Pro Logic operation
1.0% (clip threshold) at 1 kHz
Front 2X70 W (6 Ω)
Center 70 W (6 Ω)
Surround 2X70 W (6 Ω)
Damping factor 30 (8 Ω)
Load impedance

Front
A or B 4-16 Ω
A and B 8-16 Ω
Center 4-16 Ω
Surround 4-16 Ω

SMPTE intermodulation 0.3% (8 Ω)

■ PRE AMPLIFIER SECTION

Frequency response
CD, TAPE, VCR 1, VCR 2, VCR 3, VDP, VDP6CH, TV 20 Hz-20 kHz, ±1 dB

Input sensitivity and impedance
CD, TAPE, VCR 1, VCR 2, VCR 3, VDP, VDP6CH, TV 300 mV/34 kΩ

S/N (IHF A)
CD, TAPE, VCR 1, VCR 2, VCR 3, VDP, VDP6CH, TV 70 dB

Tone controls
BASS 50 Hz, +10 to -10 dB
TREBLE 20 kHz, +10 to -10 dB

■ FM TUNER SECTION

Frequency range 87.50-108.00 MHz

Sensitivity
S/N 30 dB 1.5 μV/75 Ω
S/N 26 dB 1.3 μV/75 Ω
S/N 20 dB 1.2 μV/75 Ω
Sensitivity (IHF'58) 1.5 μV/75 Ω
46 dB quieting sensitivity (IHF'58) 22 μV/75 Ω

Total harmonic distortion
MONO 0.2%
STEREO 0.3%

S/N
MONO 60 dB (75 dB, IHF)
STEREO 58 dB (71 dB, IHF)

Frequency response 20 Hz-15 kHz, +1 dB, -2 dB

Alternate channel selectivity 65 dB

±400 kHz 1 dB

Capture ratio 40 dB

Image rejection at 98 MHz 70 dB

IF rejection at 98 MHz 70 dB

Spurious response rejection at 98 MHz 50 dB

AM suppression 40 dB

Stereo separation
1 kHz 40 dB

Carrier leak
19 kHz -30 dB (-35 dB, IHF)

38 kHz -50 dB (-55 dB, IHF)

Channel balance (250 Hz-6.3 kHz) ±1.5 dB

Limiting point 1.2 μV

Bandwidth
IF amplifier 180 kHz
FM demodulator 1000 kHz
Antenna terminal(s) 75 Ω (unbalanced)

■ AM TUNER SECTION

● For (E, EB) areas.
Frequency range
MW 522-1611 kHz (9 kHz steps)
530-1620 kHz (10 kHz steps)
144-288 kHz

LW
Sensitivity
MW 20 μV, 330 μV/m
LW 45 μV

Selectivity
MW (at 999 kHz) 55 dB
LW (at 252 kHz) 55 dB

Image rejection
MW (at 999 kHz) 40 dB
LW (at 252 kHz) 40 dB

IF rejection
MW (at 999 kHz) 55 dB
LW (at 252 kHz) 55 dB

● For (EG) area.
Frequency range
522-1611 kHz (9 kHz steps)
530-1620 kHz (10 kHz steps)

Sensitivity 20 μV, 330 μV/m

Selectivity at 999 kHz 55 dB

Image rejection at 999 kHz 40 dB

IF rejection at 999 kHz 55 dB

■ VIDEO SECTION

Output voltage at 1 V input (unbalanced) 1 ±0.1 Vp-p

Maximum input voltage 1.5 Vp-p

Input/output impedance 75 Ω (unbalanced)

■ GENERAL

Power supply
For (EB) area. AC 230-240 V, 50 Hz

For (E, EG) areas. AC 230 V, 50 Hz

Power consumption 280 W

Dimensions (W×H×D) 430×170×375 mm

Weight 10.7 kg

■ REMOTE CONTROL TRANSMITTER

Control keys 57 keys

Dimensions (W×H×D) 70×28×215 mm

Weight (including batteries) 160 g

Power source Two UM-4 / "AAA"

(Panasonic R03 / LR03 or equivalent)

Notes:

- Design and Specifications are subject to change without notice. Weight and dimensions are approximate.
- Total harmonic distortion is measured by the digital spectrum analyzer.

Schematic Diagram (SA-TX50 Service Manual of pages 39~59.)

• This schematic diagram may be modified at any time with the development of new technology.

	Page		Page
A TUNER CIRCUIT.....	4~7	J S-VIDEO JACK CIRCUIT	14
B FL PANEL CIRCUIT.....	8~10	K VIDEO TERMINAL CIRCUIT.....	14, 15
C VOLUME CIRCUIT.....	9	L IN/OUT TERMINAL CIRCUIT	16~19
D LAMP(L) CIRCUIT	9	M MAIN CIRCUIT.....	16~23
E LAMP(R) CIRCUIT	9	N AC IN/OUT CIRCUIT.....	23
F OPERATION (1) CIRCUIT.....	10	O POWER SUPPLY CIRCUIT	23
G OPERATION (2) CIRCUIT.....	10	P POWER TRANSFORMER CIRCUIT	23
H HEADPHONES JACK CIRCUIT	10	Q SPEAKERS TERMINAL (1) CIRCUIT.....	23
I DIGITAL CIRCUIT.....	11~13	R SPEAKERS TERMINAL (2) CIRCUIT.....	23

Note :

- S901: Playback mode select (SFC) switch.
- S902: Playback mode select (5CH CINEMA) switch.
- S903: Center mode select (— CENTER MODE) switch.
- S904: Power "STANDBY / ON" (POWER, STANDBY /ON) switch.
- S905: Subwoofer OFF/ ON (— SUBWOOFER OFF/ ON) switch.
- S906: Help/ reset (— HELP— RESET) switch.
- S907: Playback mode select (STEREO) switch.
- S908: Speaker select (SPEAKERS A) switch.
- S909: Playback mode select (SURROUND) switch.
- S910: Playback mode select (MONO) switch.
- S911: Speaker select (SPEAKERS B) switch.
- S912: Playback mode select (3 STEREO) switch.
- S913: Delay time adjust (— DELAY TIME) switch.
- S914: Band select (BAND) switch.
- S915: Tuning control (TUNING \wedge) switch.
- S916: Input select (INPUT SELECTOR \lt) switch.
- S917: FM mode select (FM AUTO / MONO) switch.
- S918: Preset channel select (PRESET \vee) switch.
- S919: Input select (INPUT SELECTOR \gt) switch.
- S920: Memory (MEMORY) switch.
- S921: Preset channel select (PRESET \wedge) switch.
- S922: Tuning control (TUNING \vee) switch.
- VR350, 351: Power meter adjustment VR.
- VR450: Volume control VR.
- VR901: Bass control VR.
- VR902: Treble control VR.
- Signal line
 - : FM OSC signal
 - : AM(MW/LW) OSC signal
 - : Rec out signal (Lch)
 - : Surround speaker drive signal (Lch)
 - : Positive voltage lines
 - : Negative voltage lines
 - : FM signal
 - : AM(MW/LW) signal
 - : Center speaker drive signal (Lch)
 - : Subwoofer speaker drive signal

- Important safety notice:
Components identified by \triangle mark have special characteristics important for safety.
Furthermore, special parts which have purpose of fire-retardant (resistors), high-quality sound (capacitors), low-noise (resistors), etc. are used as occasion calls. When replacing any of components, be sure to use only manufacture's specified parts shown in the parts list.
- The supply part number is described alone in the replacement parts.
- All voltage values shown in circuitry are DC voltage in FM signal (Stereo signal) reception mode.
* Figures in () Stand for DC-voltage in AM(MW) signal reception mode.
* Figures in \lt \gt Stand for DC-voltage in LW signal reception mode.
- The supply part number is described alone in the replacement parts.

Parts No.	Production Parts No.	Supply Parts No.
IC405	AN79L05TA	AN79L05
IC1101, 1102 IC1109 ~ 1111	NJM2115MTE1	NJM2115MT1
IC1114, 1115	LM2940T5M	LM2940T5

Caution!

- IC and LSI are sensitive to static electricity.
Secondary trouble can be prevented by taking care during repair.
- Cover the parts boxes made of plastics with aluminum foil.
- Ground the soldering iron.
- Put a conductive mat on the work table.
- Do not touch the legs of IC or LSI with the fingers directly.

A TUNER CIRCUIT For [E,EB] areas. (P.C. Board: on page 24)

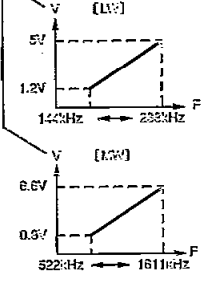
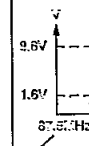
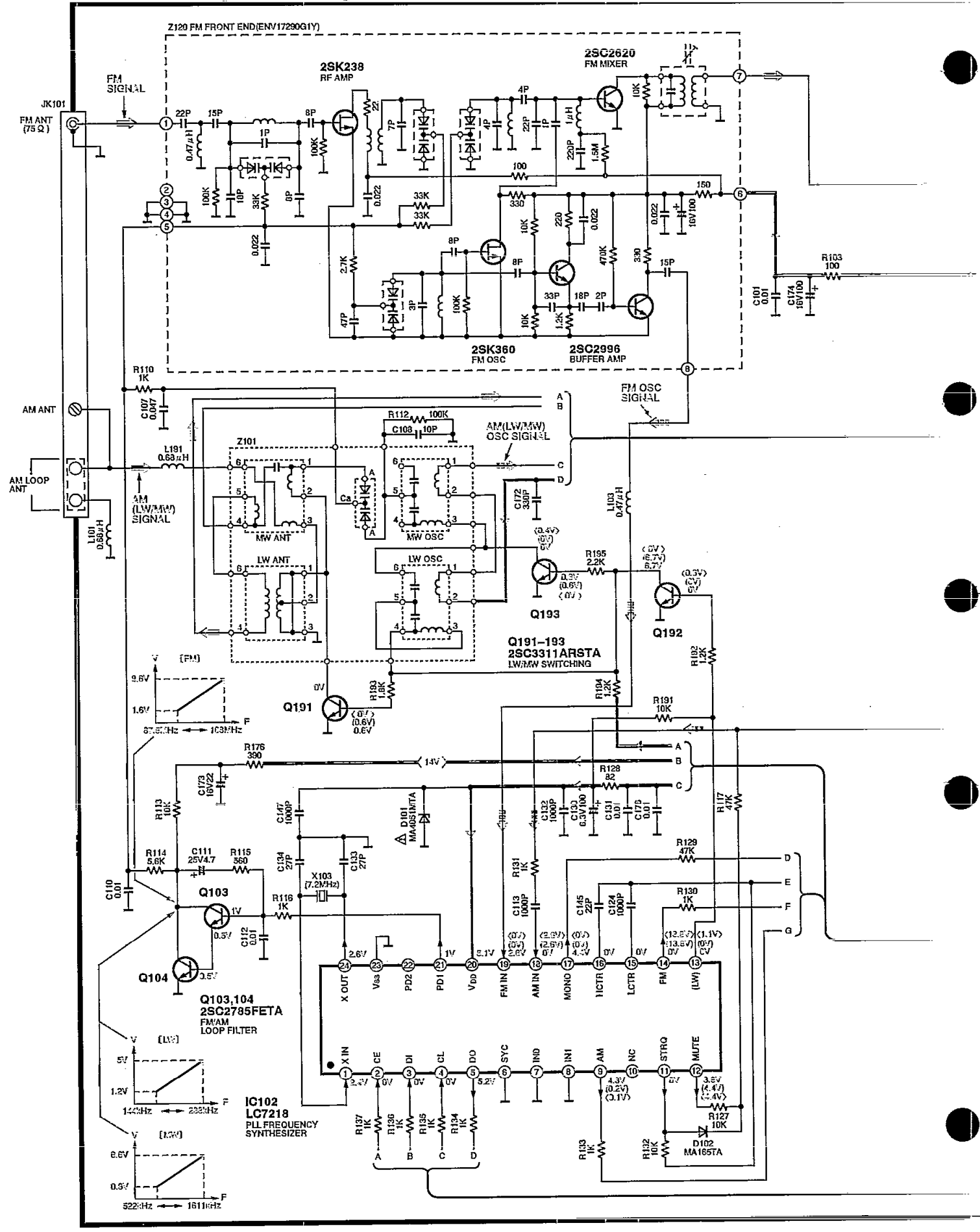

Notes: ● → : FM signal ● □ □ □ □ → : FM OSC signal
 ● → : AM signal ● □ □ □ □ → : AM OSC signal

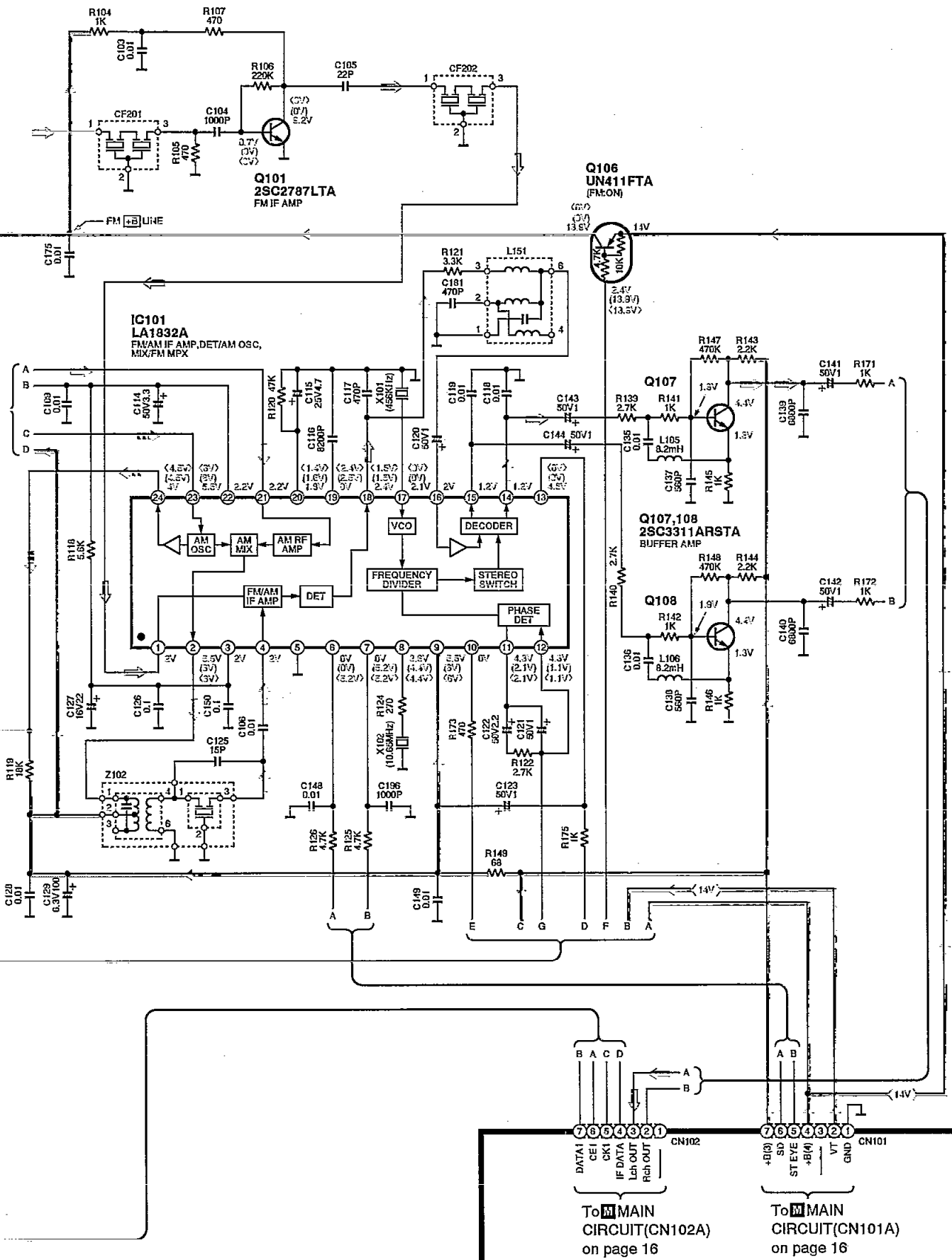

Notes: ● → : FM signal ● □□□□ → : FM OSC signal
 ● → : AM signal ● □□□□ → : AM OSC signal

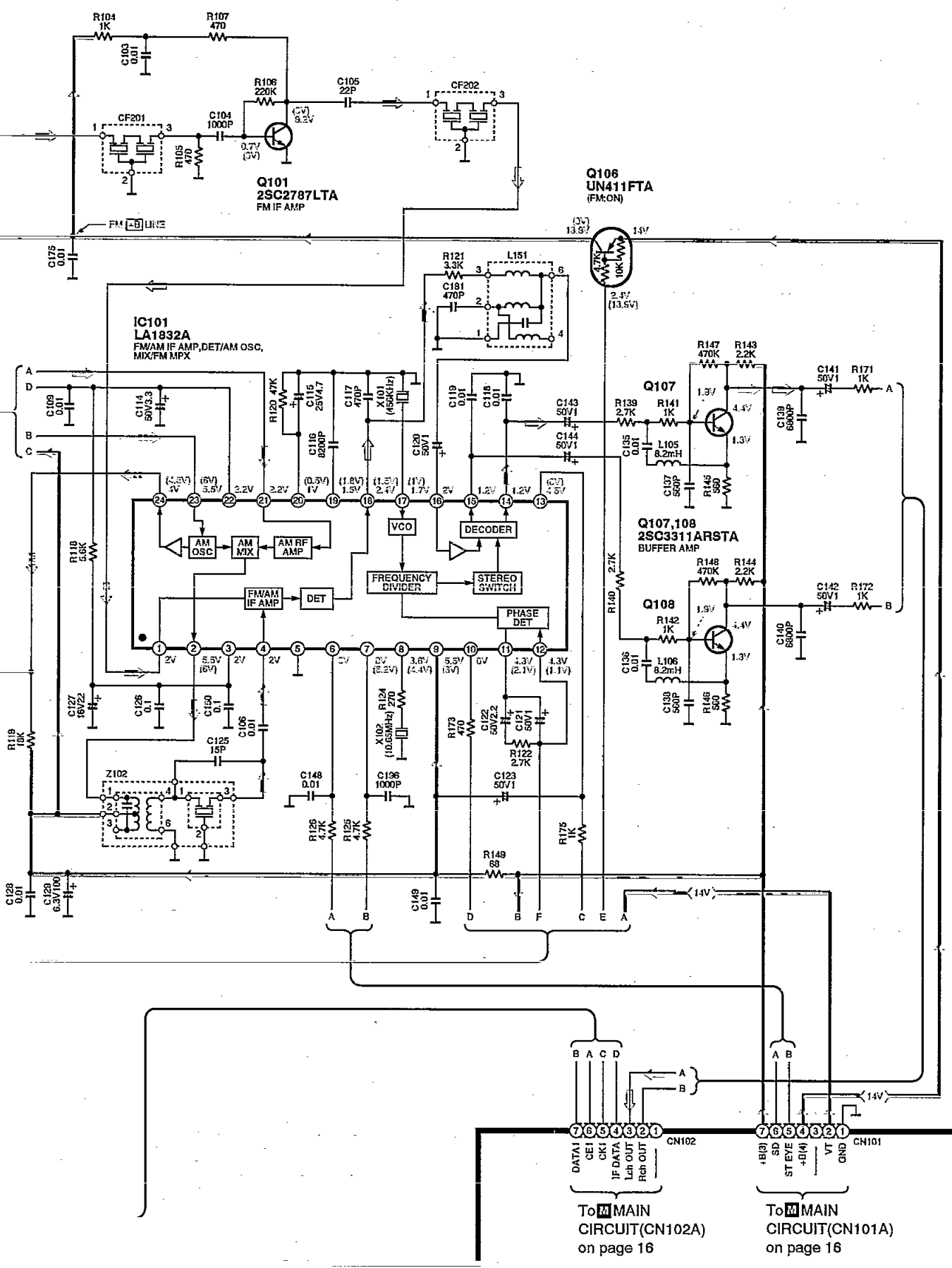

B FL PANEL CIRCUIT (P.C. Board: on page 25)

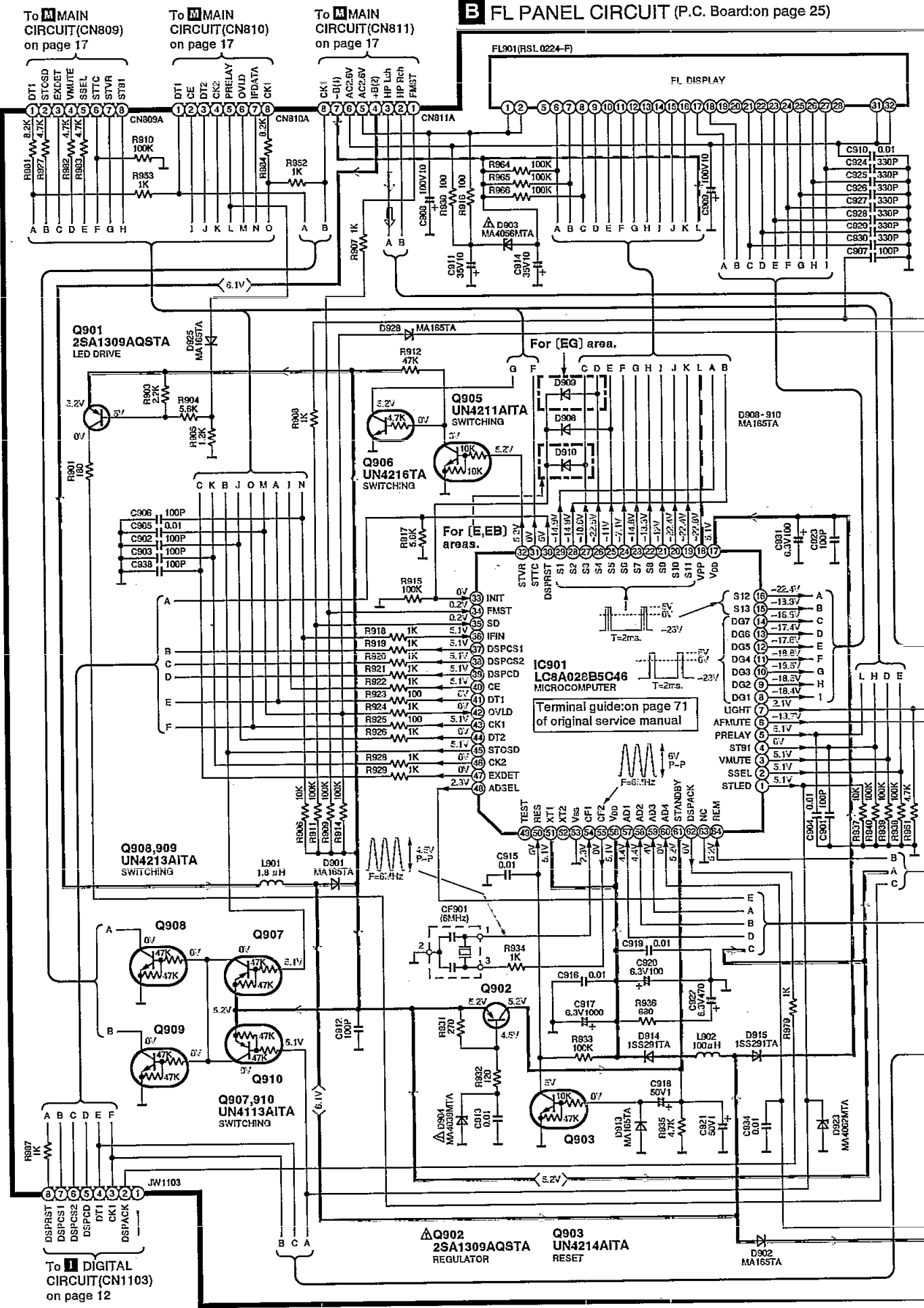

Notes: ● → : FM signal
 ● → : AM signal

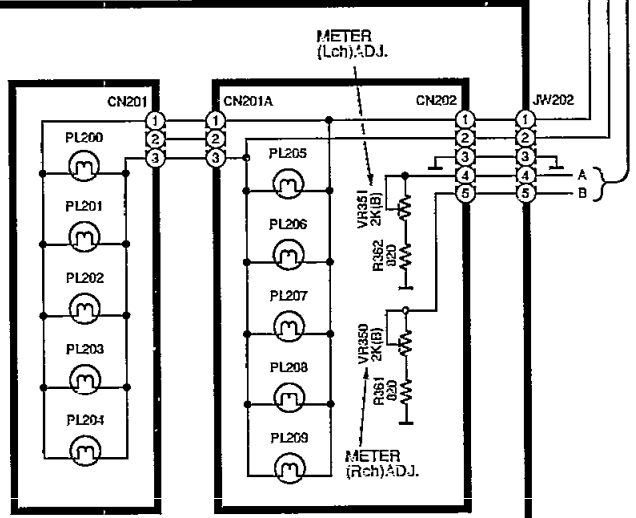
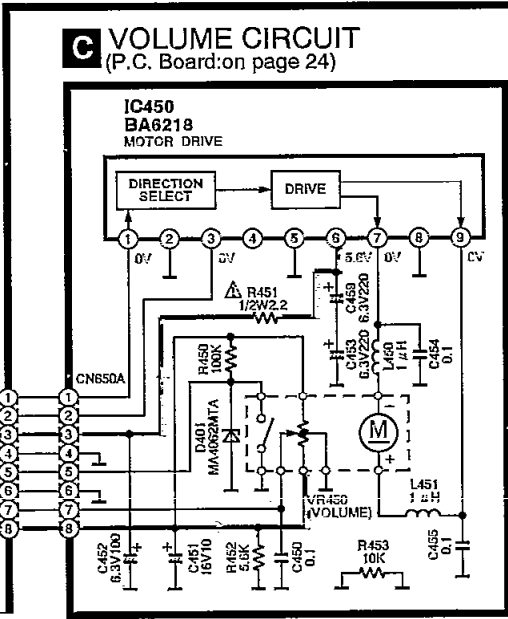
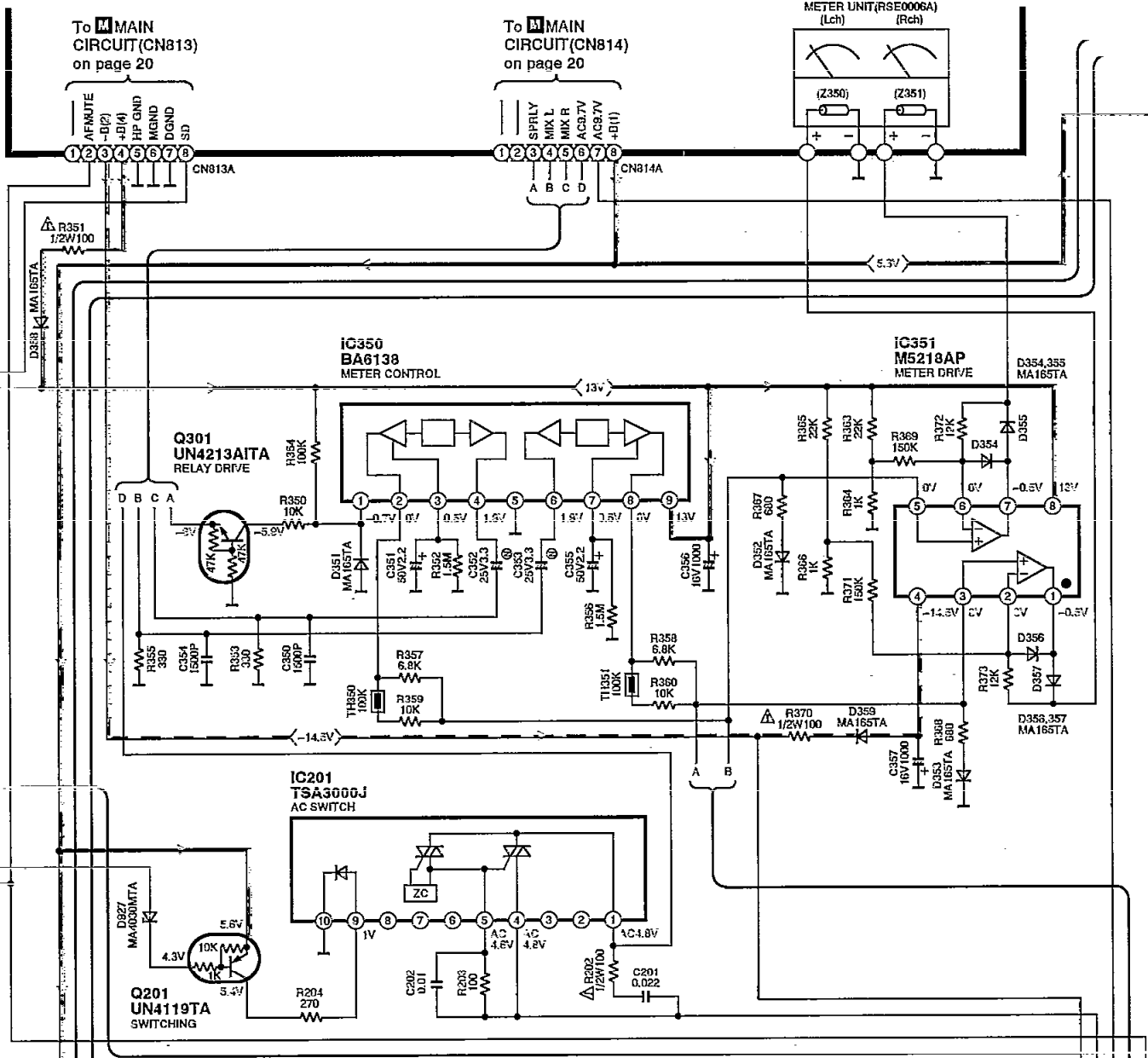

B FL PANEL CIRCUIT (P.C. Board: on page 25)

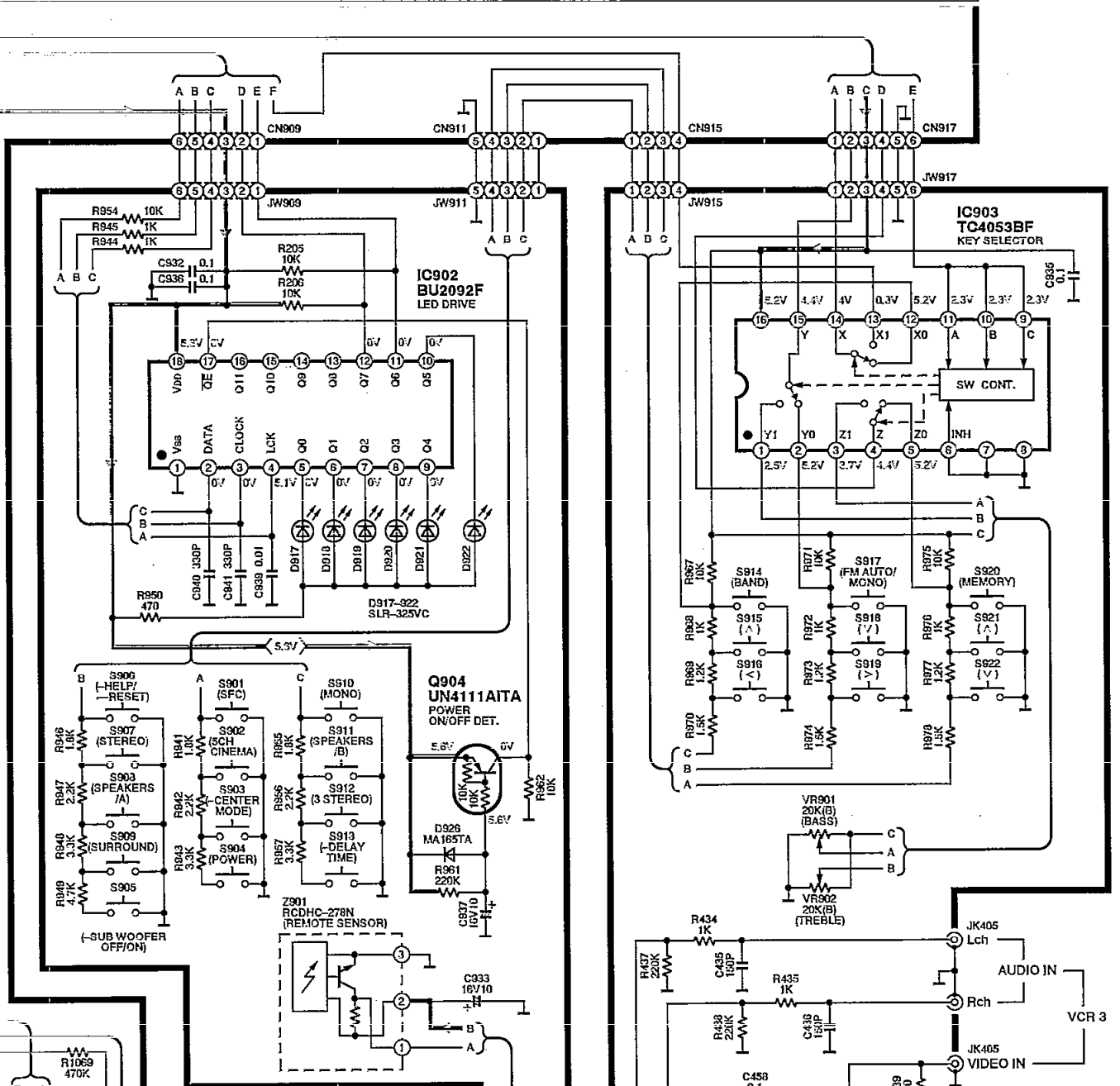

F OPERATION(1) CIRCUIT (P.C. Board: on page 26)

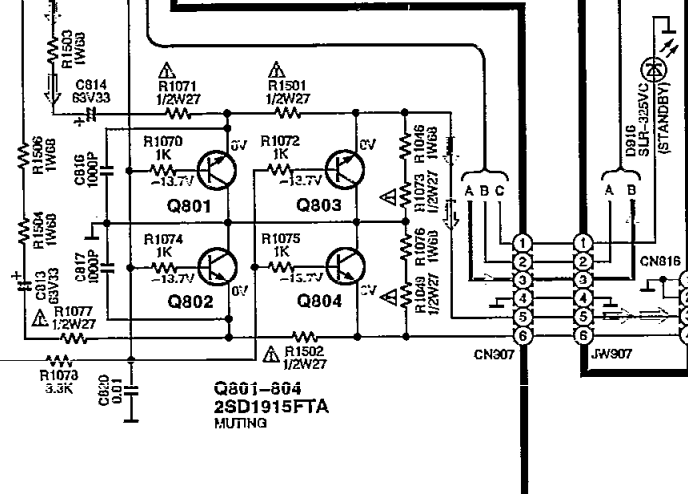

G OPERATION(2) CIRCUIT (P.C. Board: on page 27)

To **L** IN/OUT TERMINAL CIRCUIT (CN401) on page 16
 To **K** VIDEO TERMINAL CIRCUIT (CN1306) on page 15

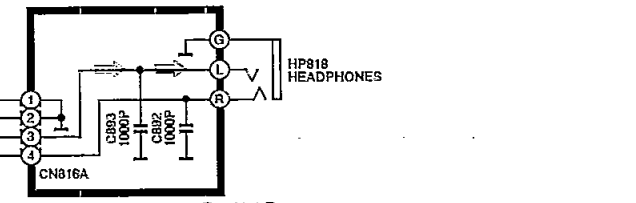

H HEADPHONES JACK CIRCUIT (P.C. Board: on page 27)



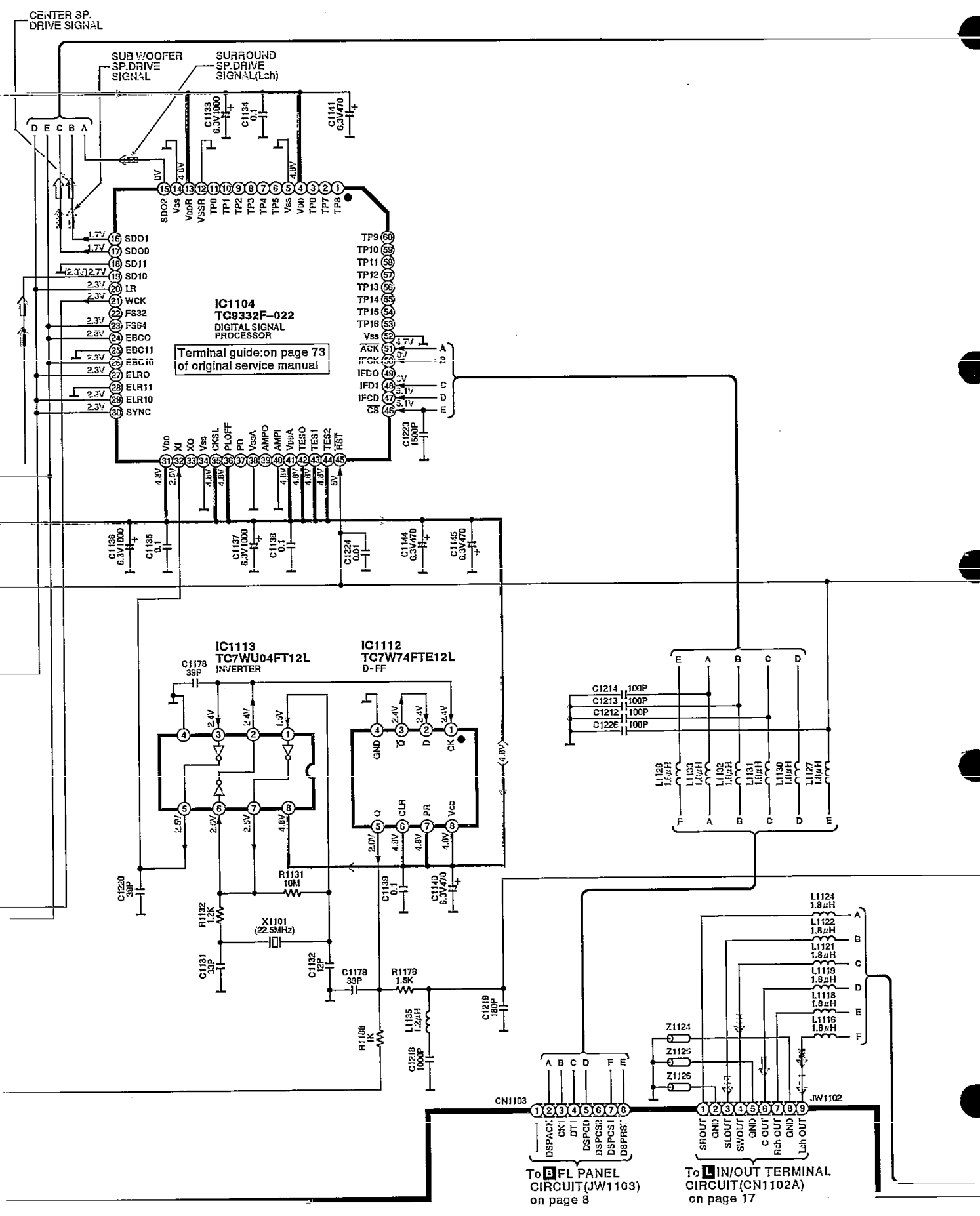

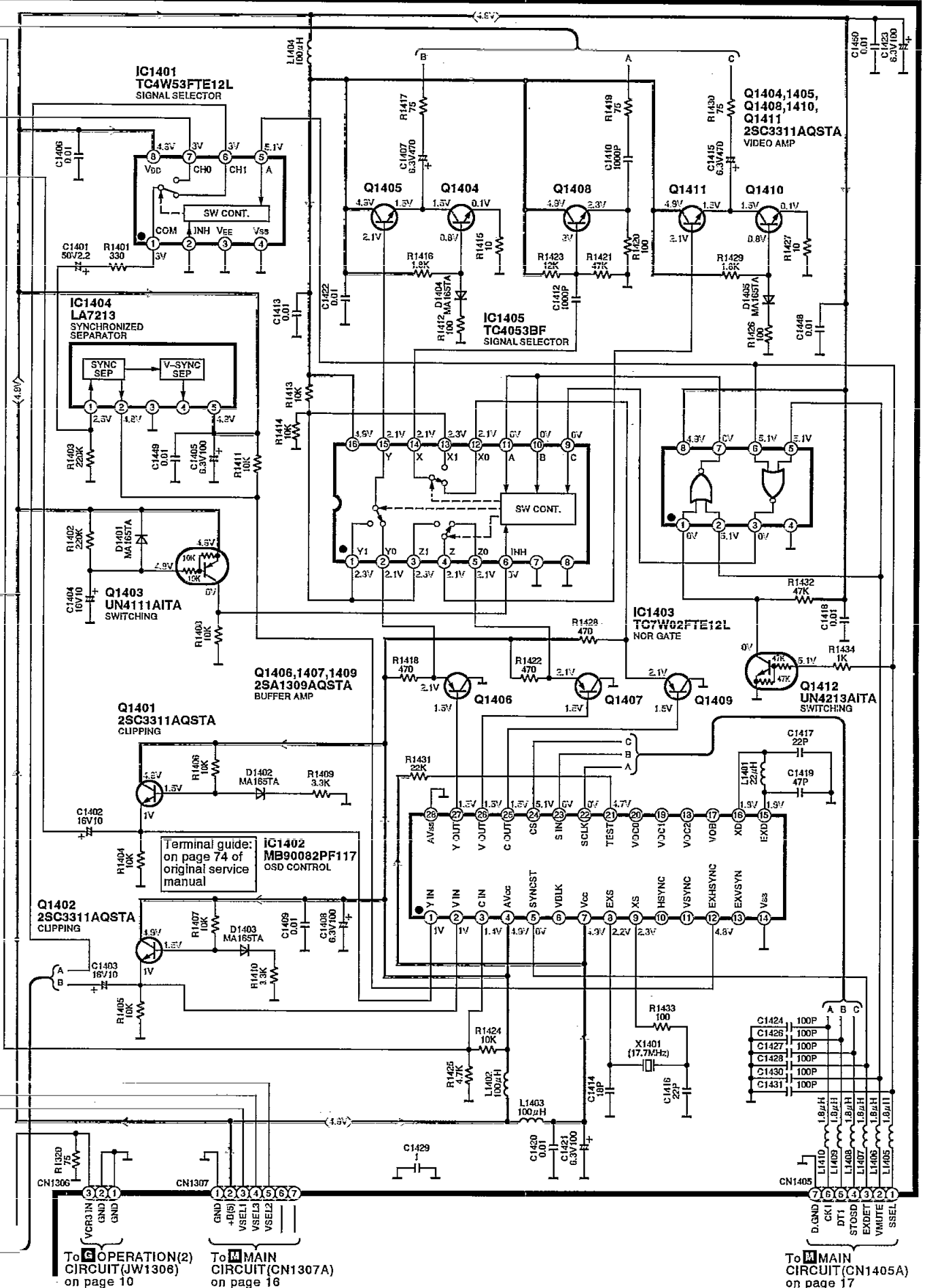

To **OPERATION**(2)
CIRCUIT(JW1306)
on page 10

To **MAIN**
CIRCUIT(CN1307A)
on page 16

To **MAIN**
CIRCUIT(CN1405A)
on page 17

L IN/OUT TERMINAL CIRCUIT (P.C.Board: on page 31)

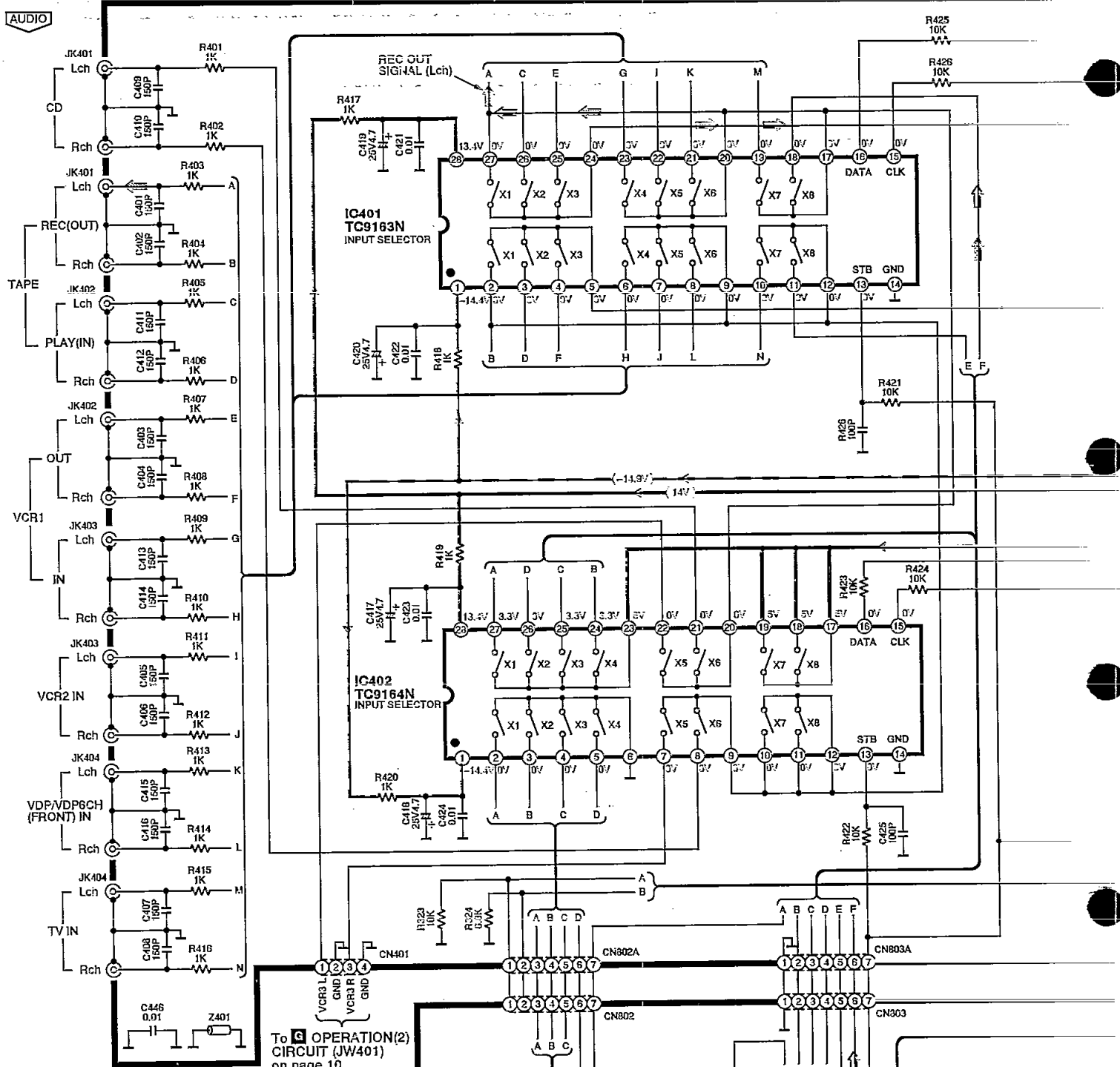

M MAIN CIRCUIT (P.C.Board: on pages 32,33)

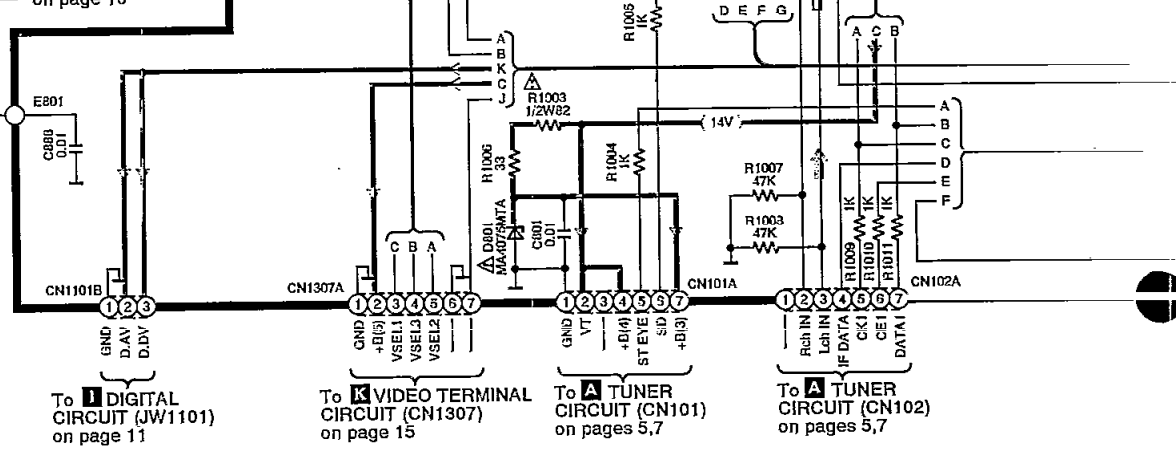

- Notes:
- : FM signal
 - : Surround speaker drive signal (Lch)
 - : Center speaker drive signal
 - : AM signal
 - : Subwoofer speaker drive signal
 - : Rec out signal (Lch)

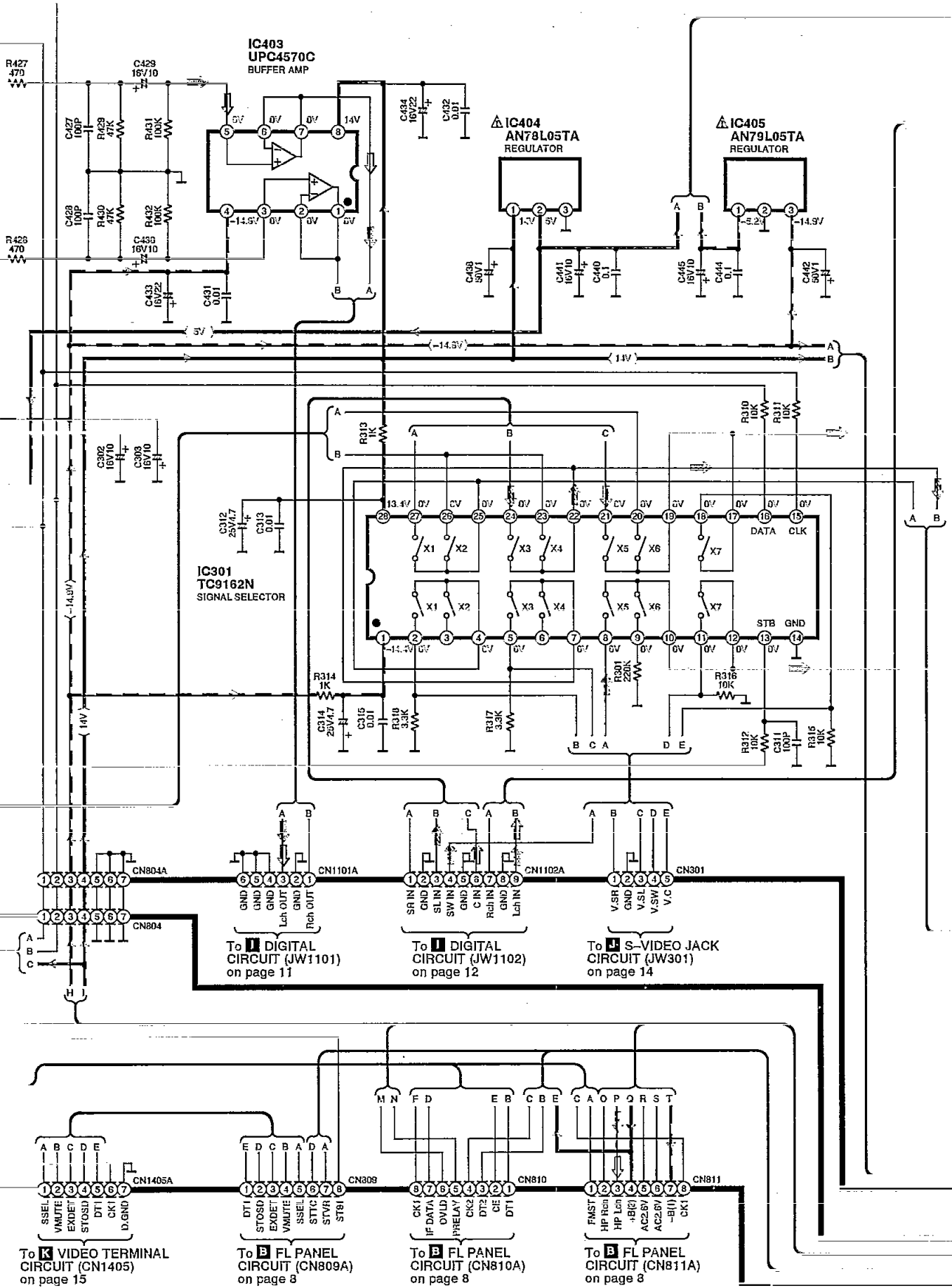

To **14** VIDEO TERMINAL CIRCUIT (CN1405) on page 15

To **13** FL PANEL CIRCUIT (CN809A) on page 8

To **12** FL PANEL CIRCUIT (CN810A) on page 8

To **11** FL PANEL CIRCUIT (CN811A) on page 8



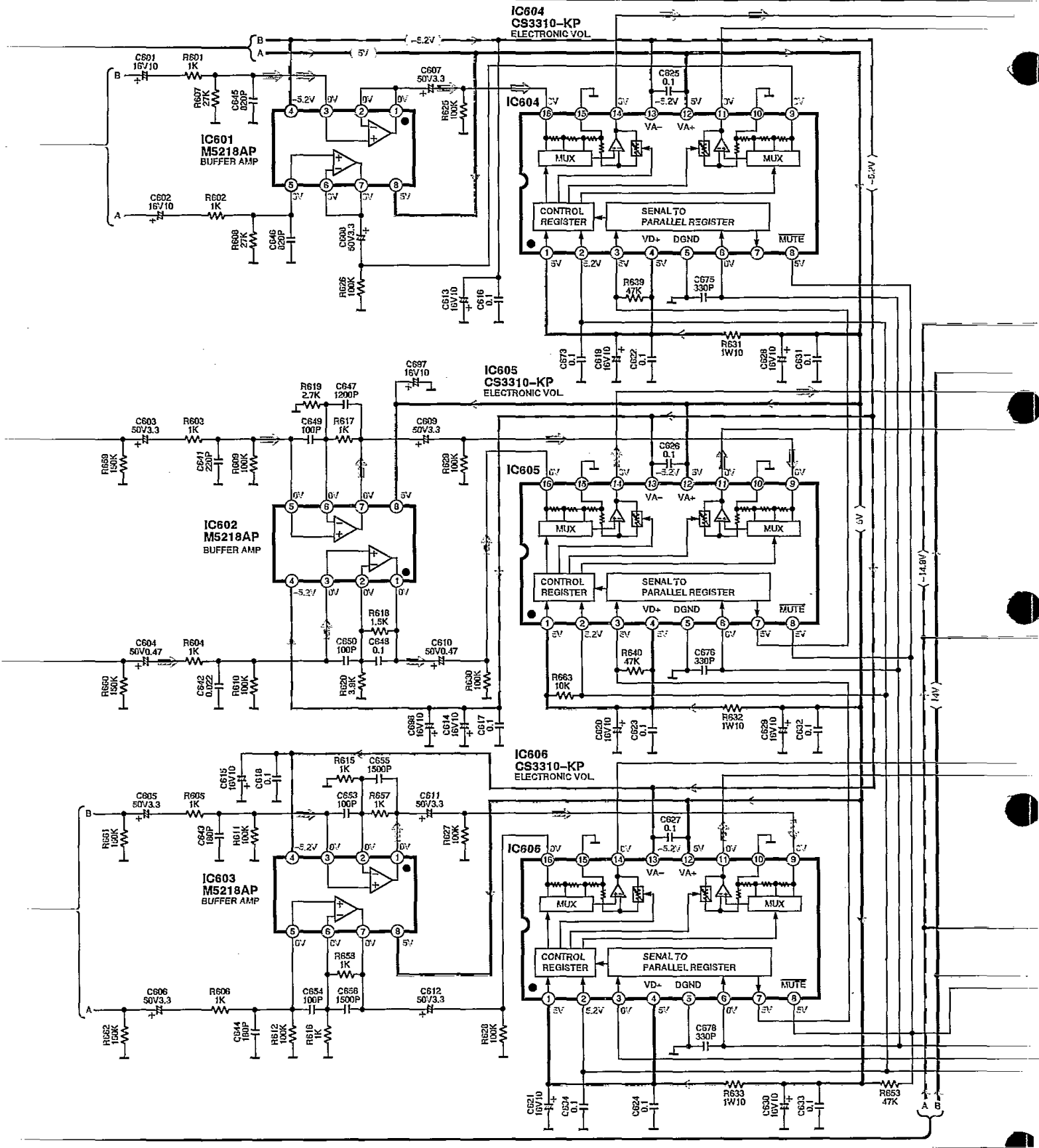

I IN/OUT TERMINAL CIRCUIT (P.C.Board: on page 31)

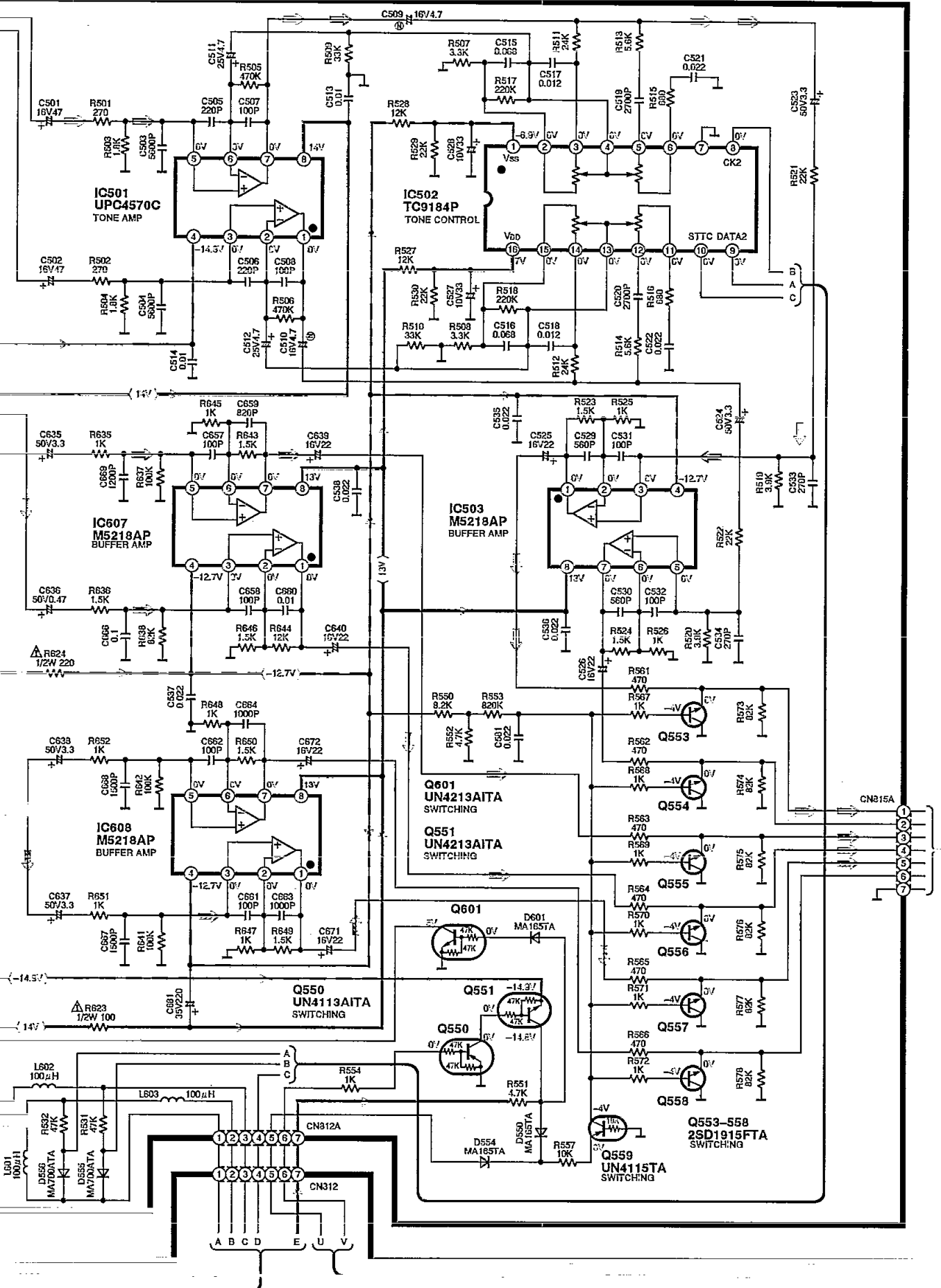

M MAIN CIRCUIT (P.C.Board: on pages 32,33)

- Notes: ● → : FM signal ● → : Surround speaker drive signal (Lch) ● → : Center speaker drive signal
 ● → : AM signal ● → : Subwoofer speaker drive signal



- Notes: ●  : FM signal ●  : Surround speaker drive signal (Lch) ●  : Center speaker drive signal
 ●  : AM signal ●  : Subwoofer speaker drive signal

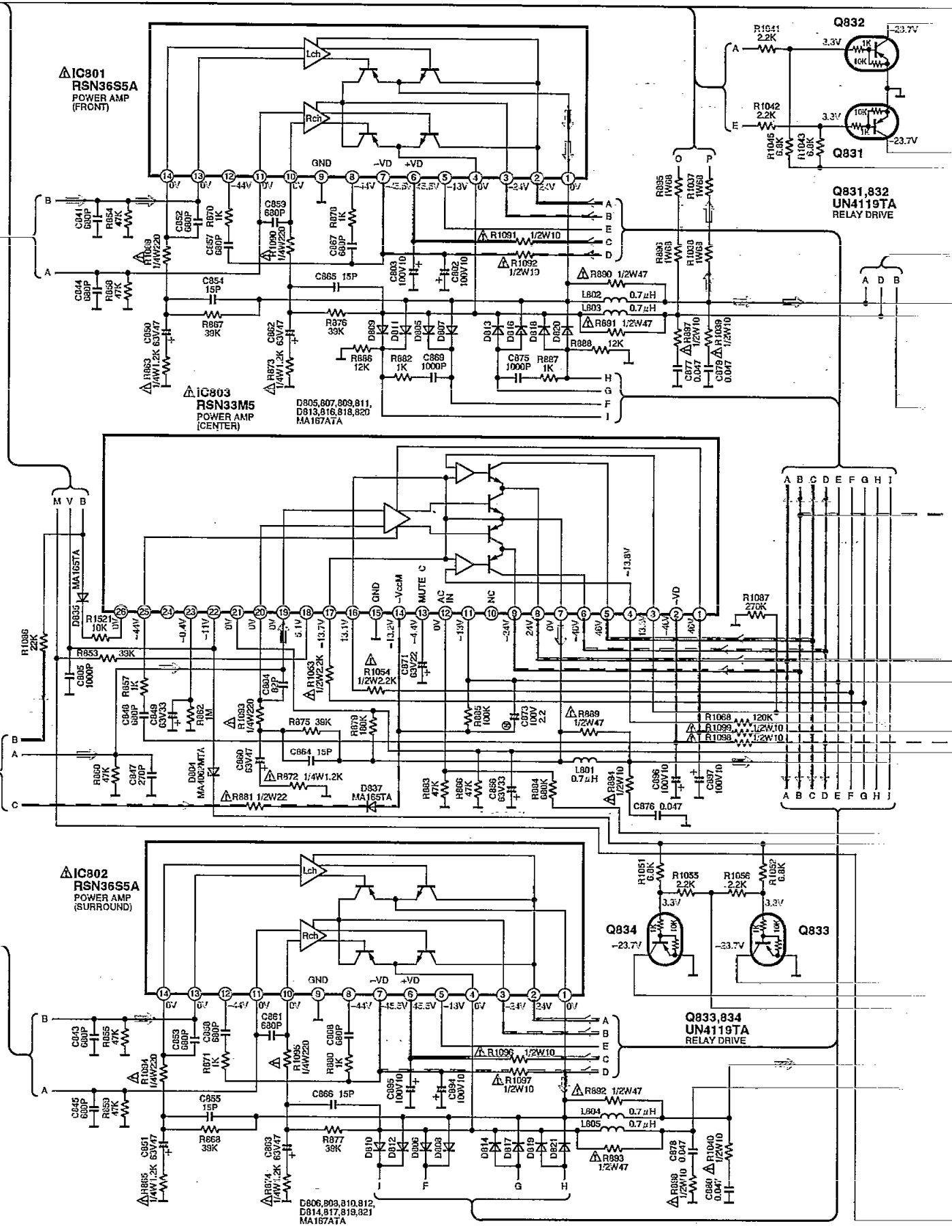

M MAIN CIRCUIT (P.C.Board: on pages 32,33)

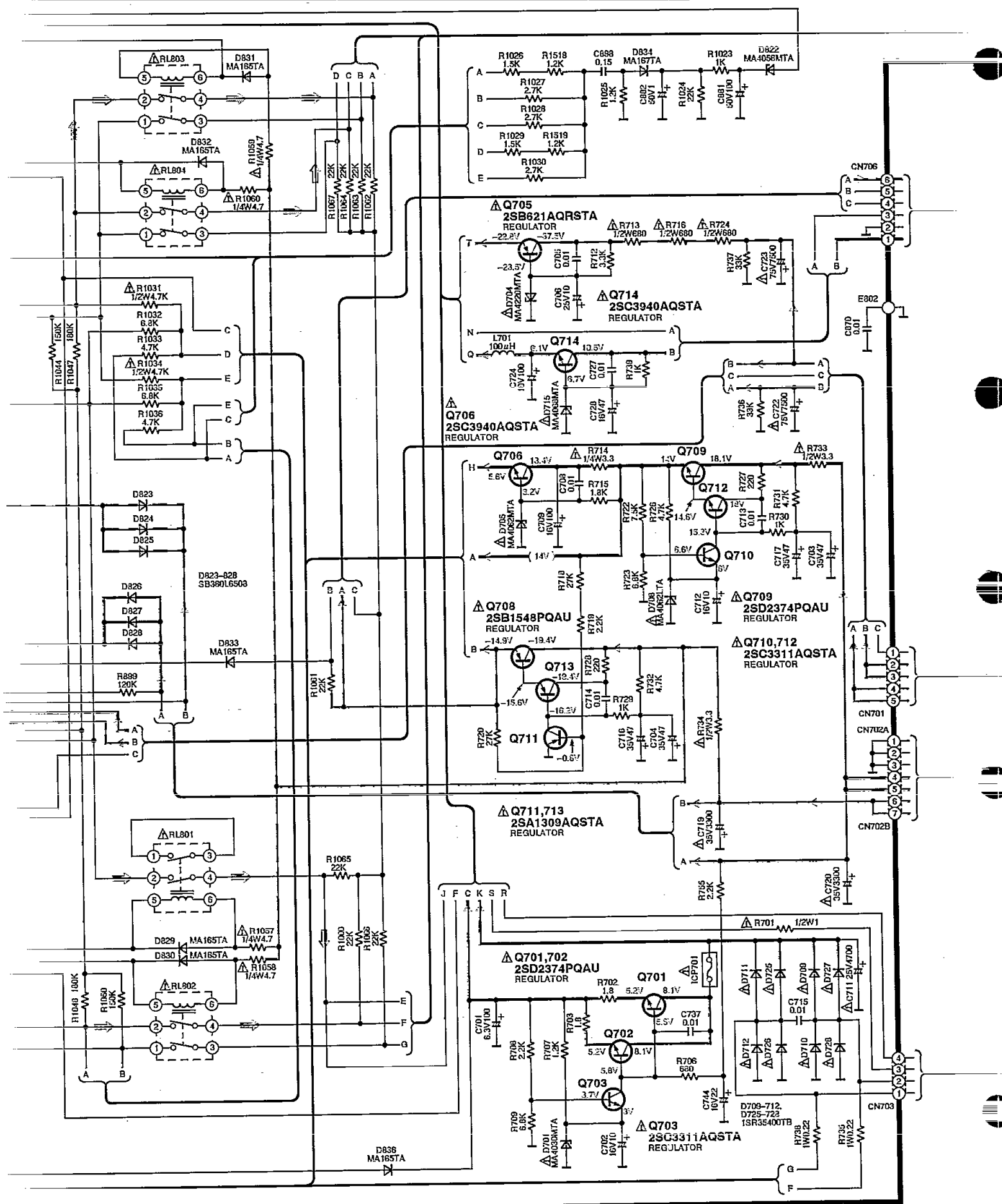

G OPERATION (2) P.C.B.

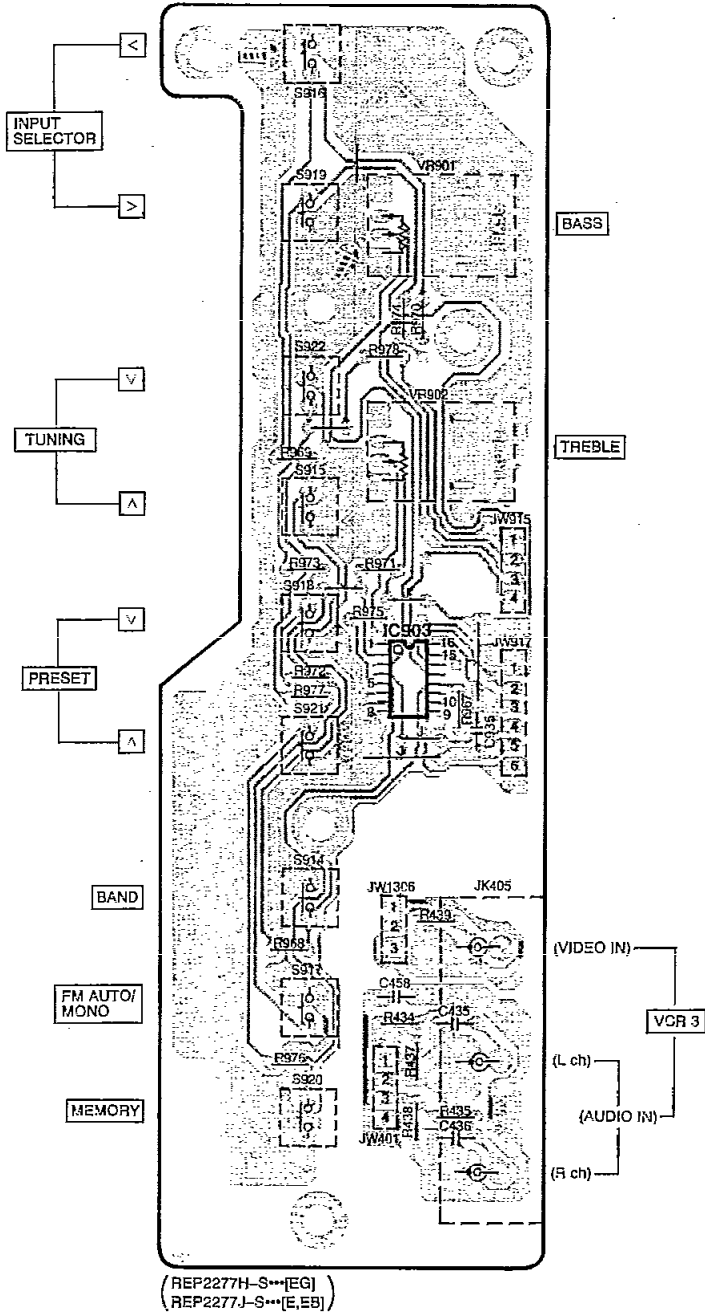

H HEADPHONES JACK P.C.B.

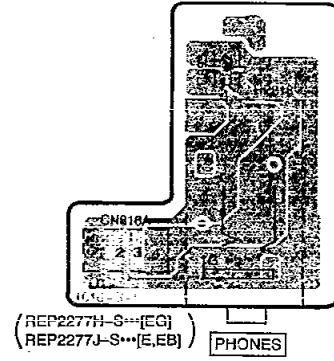

1

2

3

4

5

Notes:

• In this printed circuit board diagram, the parts and foil patterns on the board facing toward you are printed in black. The opposite side is printed in blue.

• The "⊙" mark denote the connection points of double-faced foil patterns (through holes) on both sides of the printed circuit board.

DIGITAL P.C.B.

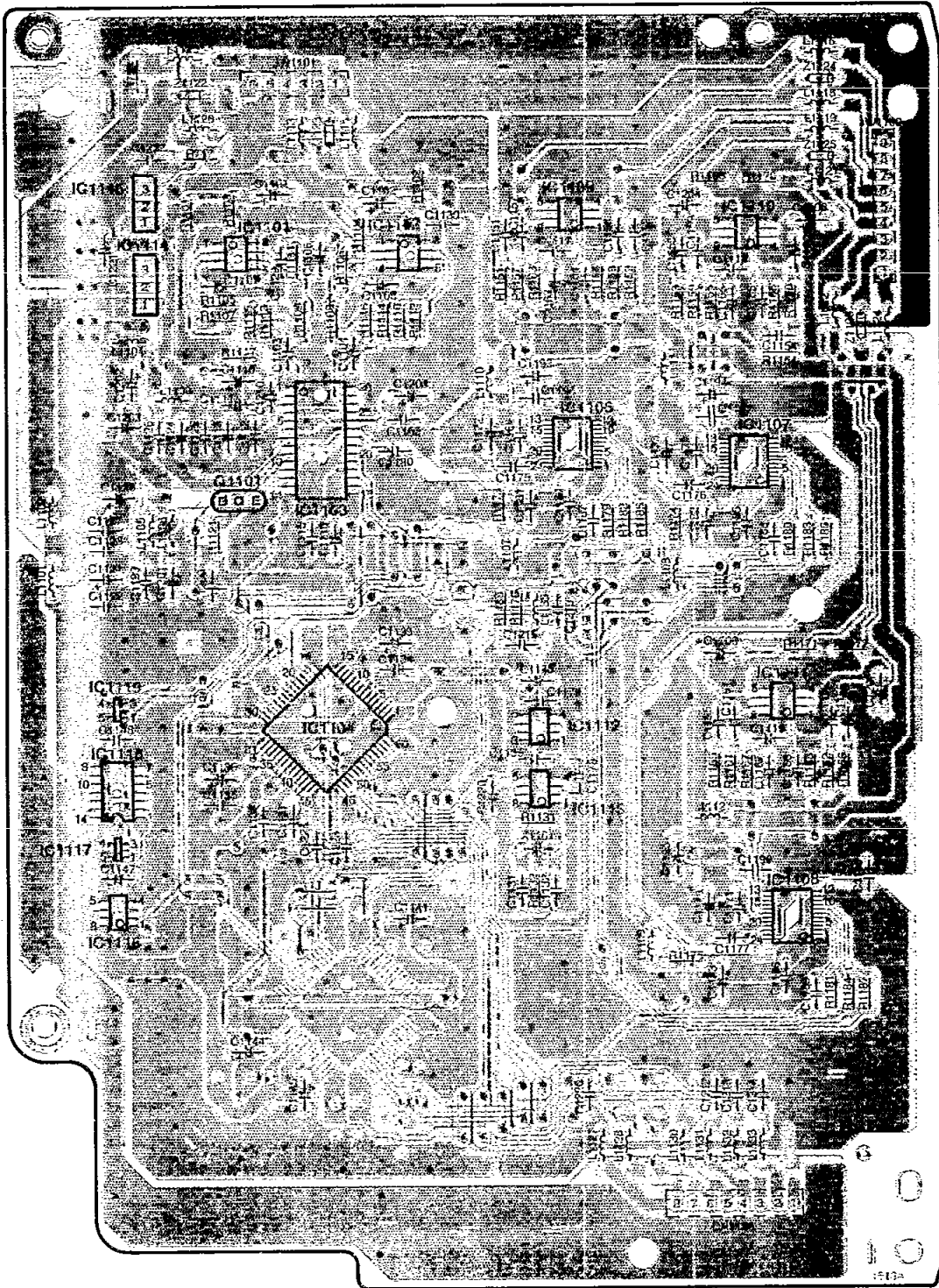

1513a
(REP2279B-T)

K VIDEO TERMINAL P.C.B.

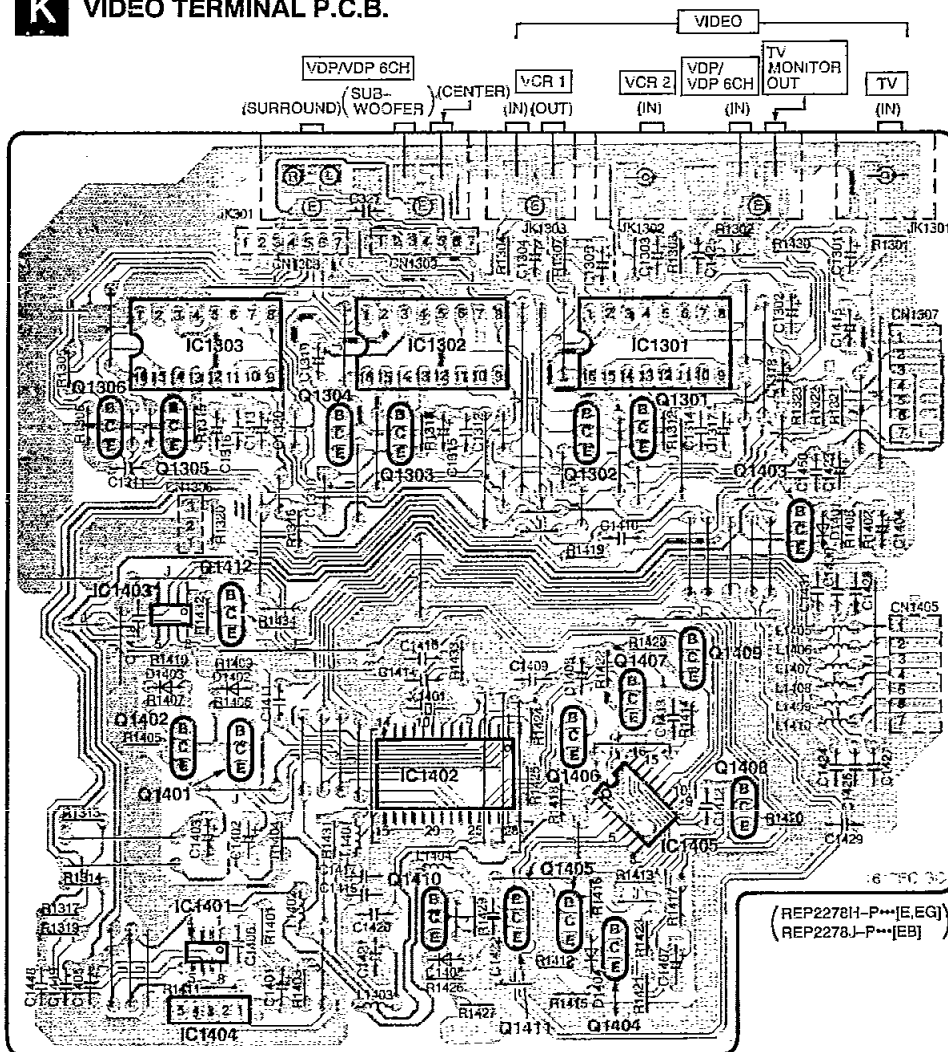

J S-VIDEO JACK P.C.B.

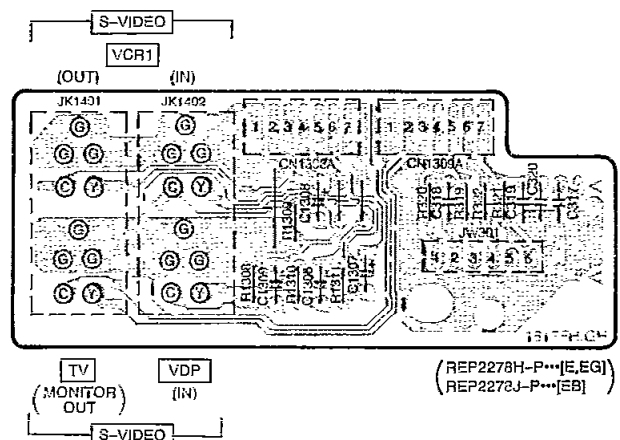

1 2 3 4 5

A

P POWER TRANSFORMER P.C.B.

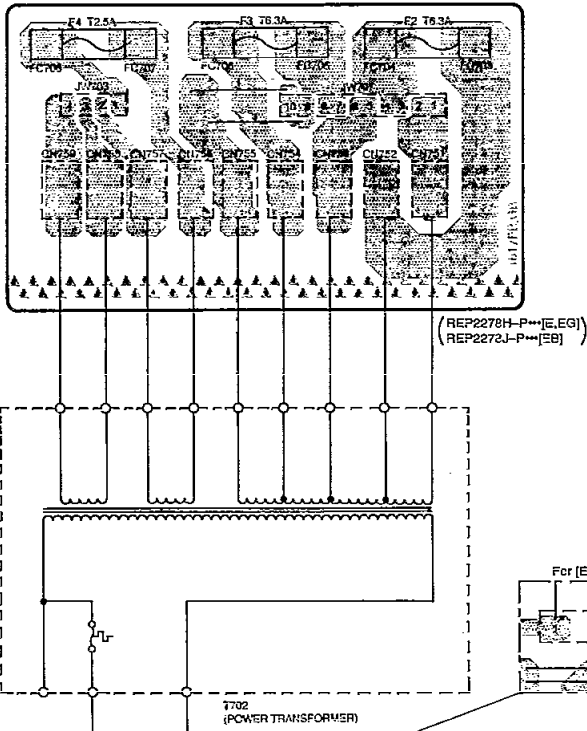

B

C

D

E

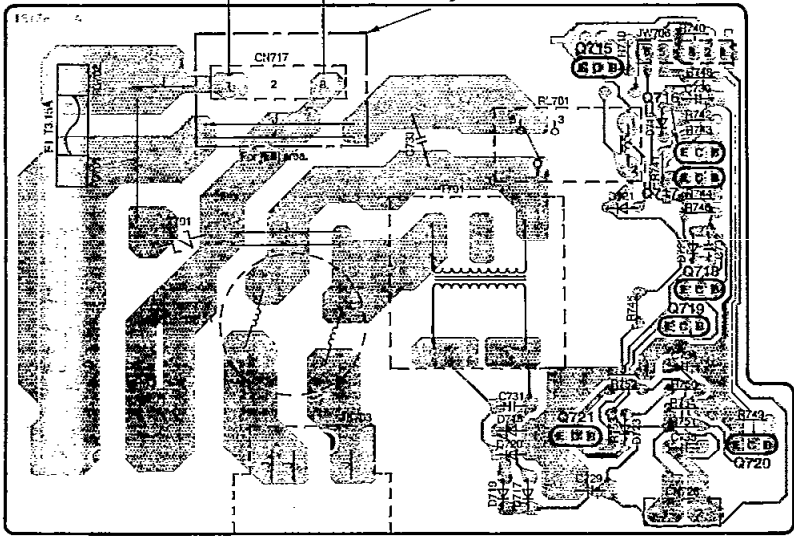

N AC IN P.C.B.

F

R SPEAKERS TERMINAL (2) P.C.B.

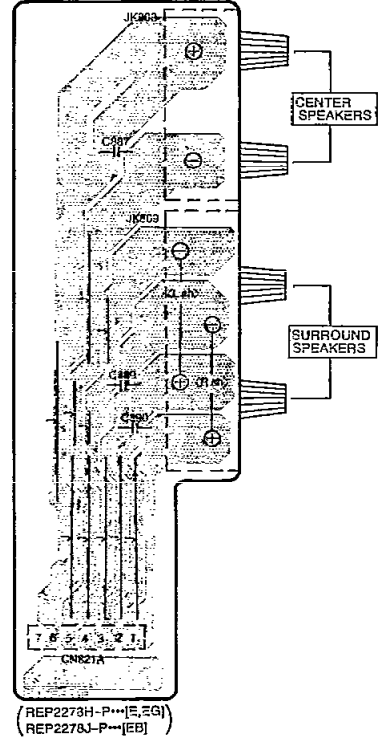

Q SPEAKERS TERMINAL (1) P.C.B.

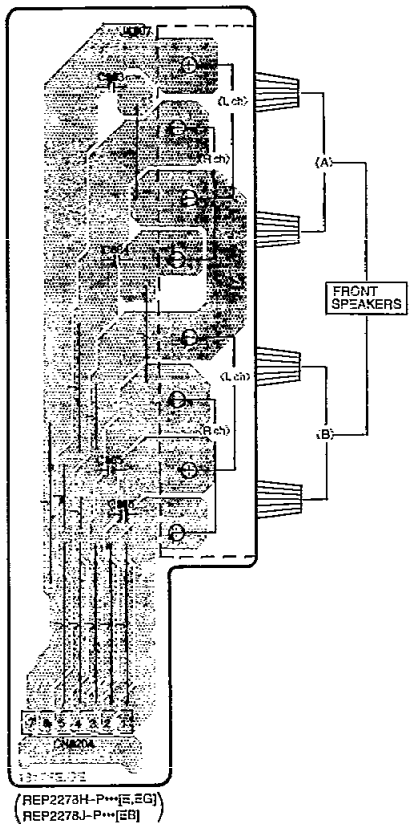

1 2 3 4 5

M MAIN P.C.B.

A

B

C

D

E

F

SUB WOOFER

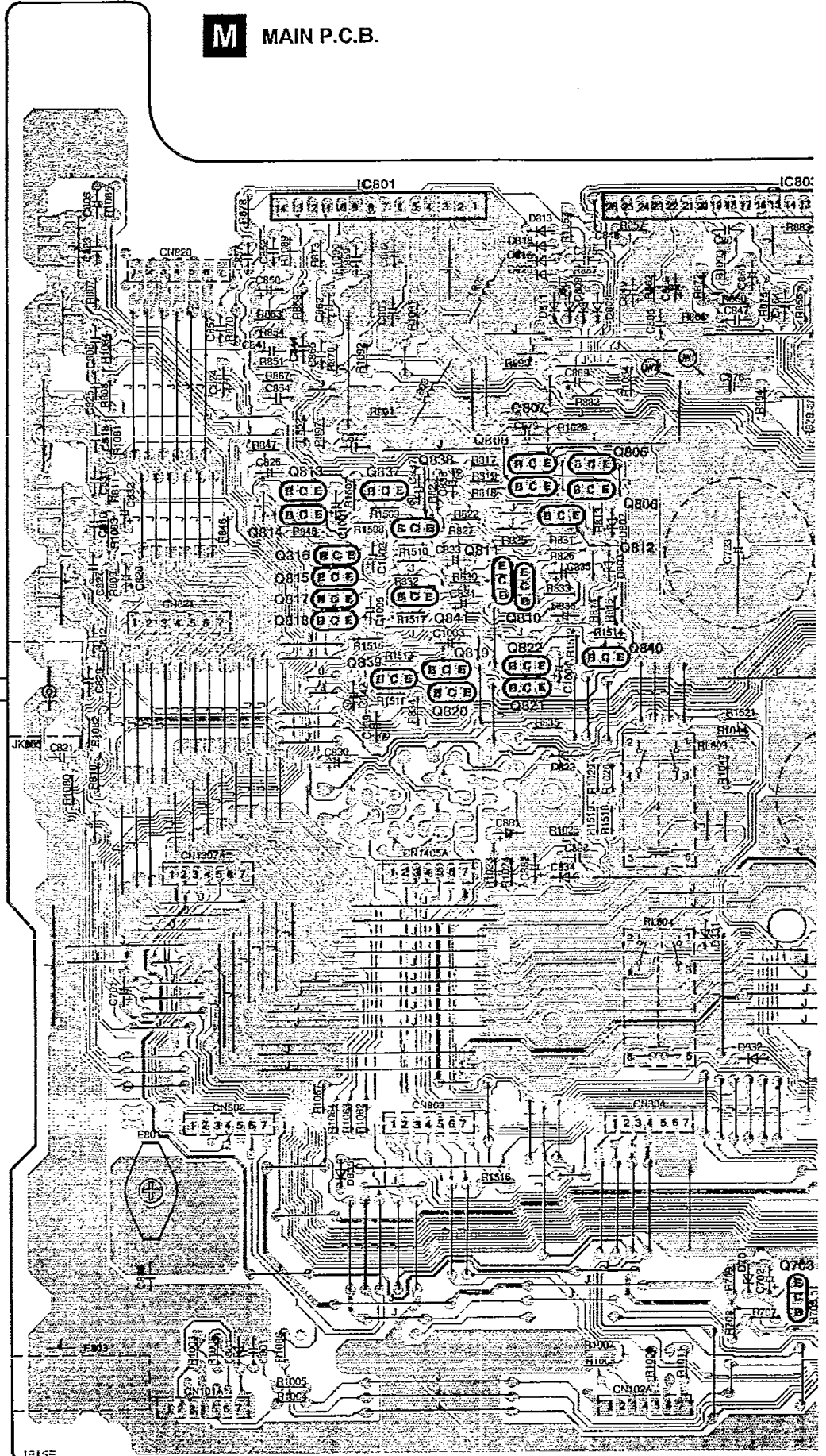

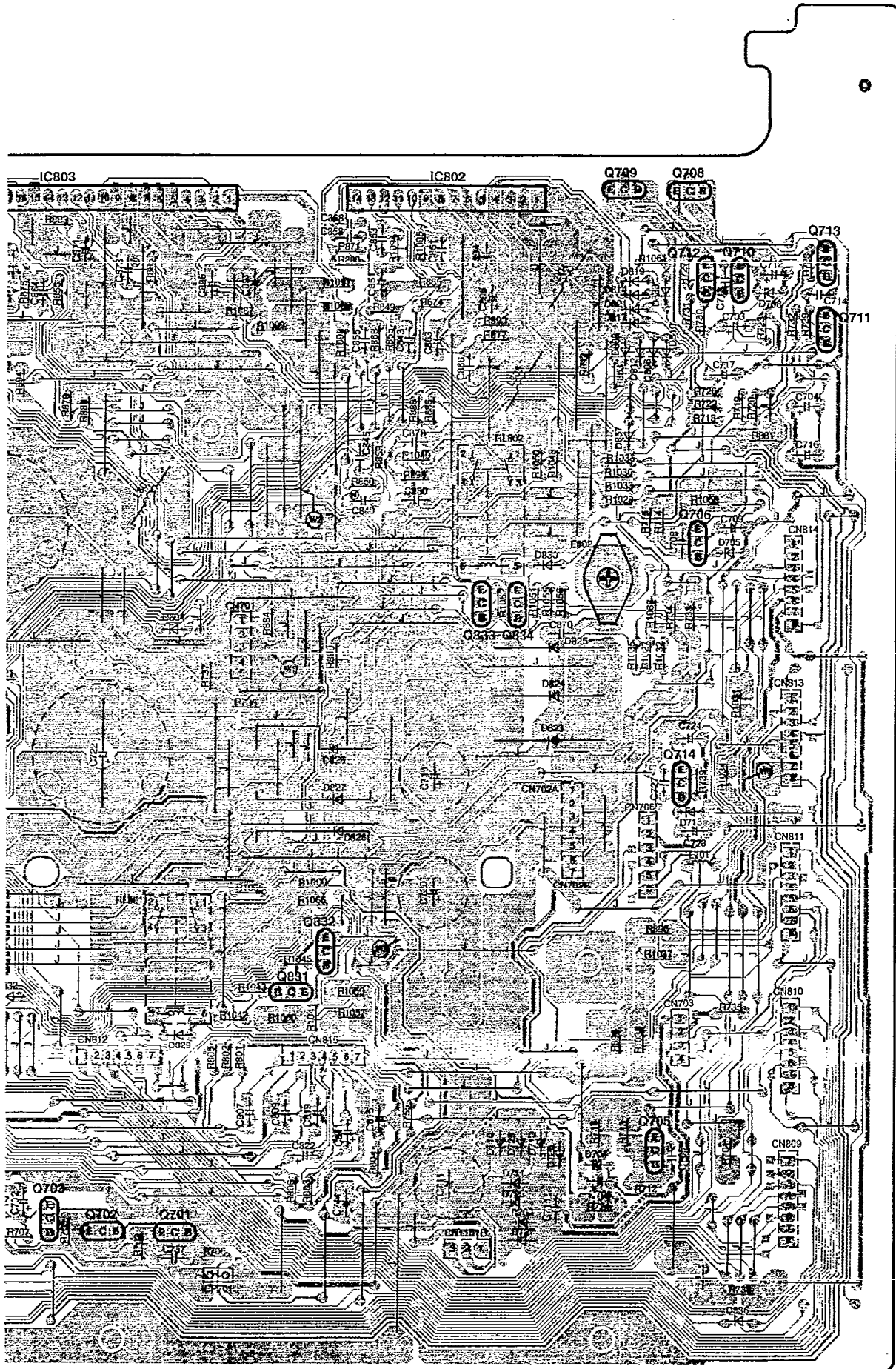

1 2 3 4 5

Cabinet Parts Location

A

B

C

D

E

F

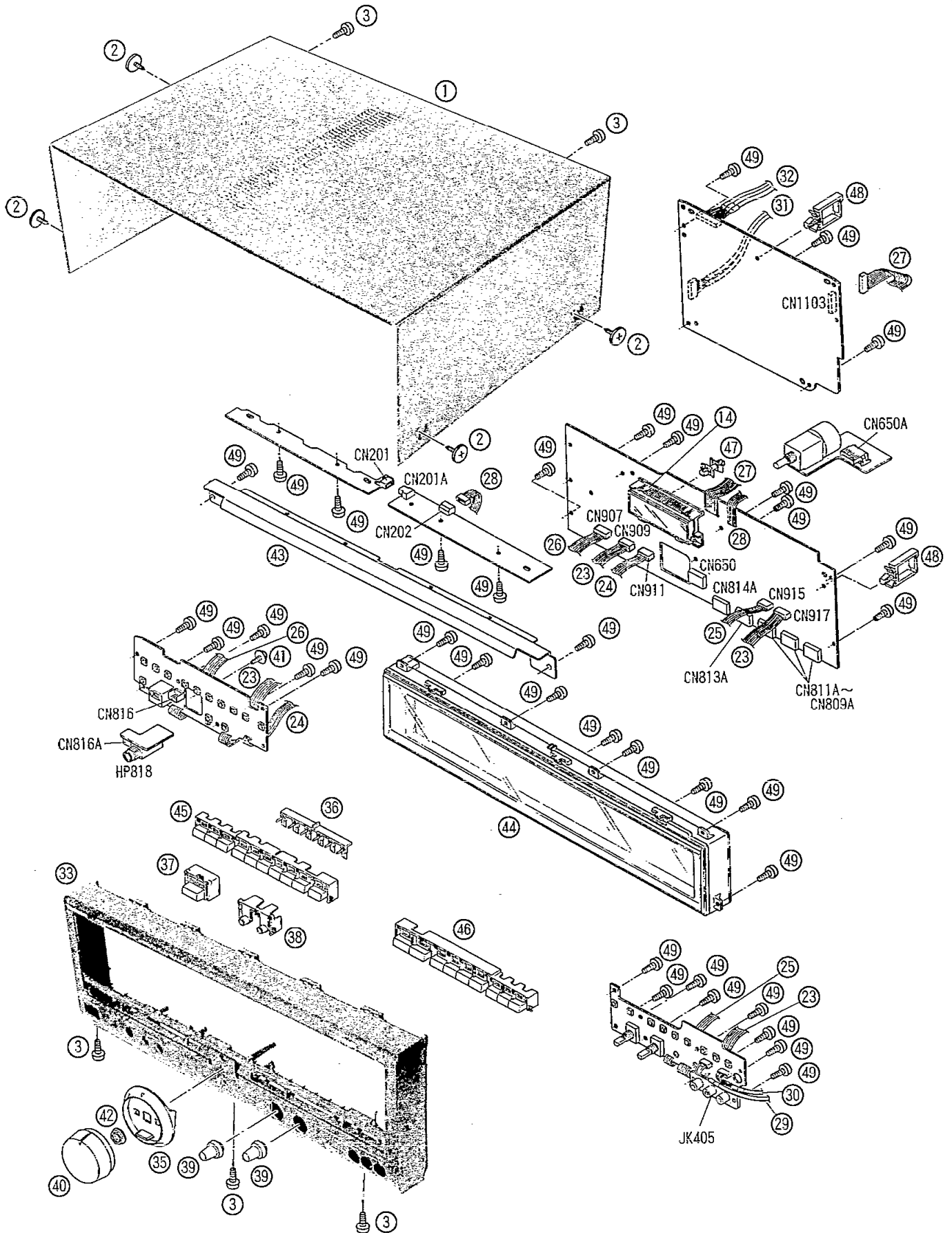

6 | 7 | 8 | 9 | 10

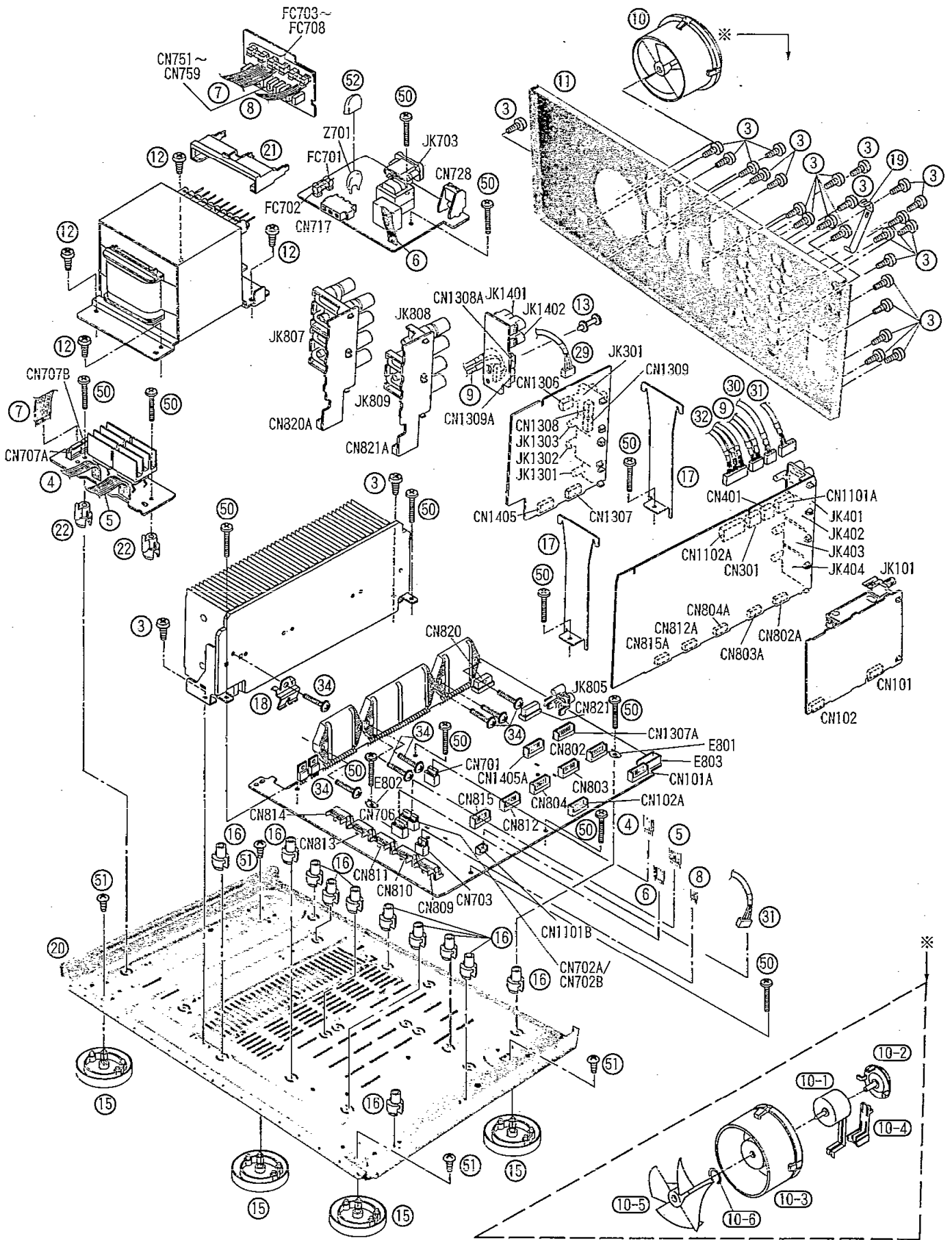

Replacement Parts List (Cabinet, Electrical)

Notes: * Important safety notice:

 Components identified by Δ mark have special characteristics important for safety.

Furthermore, special parts which have purposes of fire-retardant (resistors), high-quality sound (capacitors), low-noise (resistors), etc. are used.

When replacing any of components, be sure to use only manufacturer's specified parts shown in the parts list.

* The parenthesized indications in the Remarks columns specify the areas. (Refer to the cover page for area.)

Parts without these indications can be used for all areas.

* [M] indicates in Remarks columns parts that are supplied by MESA.

Ref. No.	Part No.	Part Name & Description	Remarks	Ref. No.	Part No.	Part Name & Description	Remarks
		CABINET AND CHASSIS		22	RMN0392	P. C. B. HOLDER	[M]
1	RRM0331A-K	CABINET	[M]	23	RWJ1806070KQ	FLAT CABLE (6P) (CN909/CN917)	[M]
2	SNE2129-3	SCREW	[M]	24	RWJ1805070KQ	FLAT CABLE (5P) (CN/JW911)	[M]
3	XTBS3+8JFZ1	SCREW	[M]	25	RWJ1804070KQ	FLAT CABLE (4P) (CN/JW915)	[M]
4	RWJ1805480KQ	FLAT CABLE (5P) (CN/JW701)	[M]	26	RWJ1806100KQ	FLAT CABLE (6P) (CN/JW907)	[M]
5	RWJ1807470KQ	FLAT CABLE (7P) (CN/JW702)	[M]	27	RFKATX50PAK	CONNECTOR ASS'Y (8P)	[M]
6	RWJ1806650KQ	FLAT CABLE (6P) (CN/JW706)	[M]	28	RFKATX50PBK	CONNECTOR ASS'Y (5P)	[M]
7	RWJ1810330KQ	FLAT CABLE (10P) (CN/JW707)	[M]	29	RFKATX50PCK	CONNECTOR ASS'Y (3P)	[M]
8	RWJ1804570KQ	FLAT CABLE (4P) (CN/JW703)	[M]	30	RFKATX50PK	CONNECTOR ASS'Y (4P)	[M]
9	REZ0924	CONNECTOR ASS'Y	[M]	31	RFKATX50PEK	CONNECTOR ASS'Y (4P)	[M]
10	REMO020-1	FAN MOTOR UNIT	[M]	32	RFKATX50PFK	CONNECTOR ASS'Y (9P)	[M]
10-1	MDN-4RB4MRC	FAN MOTOR	[M]	33	RFKATX30E-K	FRONT PANEL ASS'Y	[M]
10-2	RMQ0208-K	FAN CAP	[M]	34	XTW3+15T	SCREW	[M]
10-3	RMQ0209-K	FAN CASE	[M]	35	RGK0842B-S	ORNAMENT RING	[M]
10-4	RMQ0212-K	FAN TERMINAL CAP	[M]	36	RGL0344-Q	OPTICAL CONDUCTIVE PLATE	[M]
10-5	SHE232-1	FAN	[M]	37	RGU0882-K	POWER BUTTON	[M]
10-6	SUS271	SPRING	[M]	38	RGU1438-K	SPEAKERS SELECT BUTTON	[M]
11	RGR0244F-B	REAR PANEL	[M] (E, EG)	39	RGW0175-2K	BASS/TREBLE KNOB	[M]
11	RGR0244F-A	REAR PANEL	[M] (EB)	40	RGW0201-1K	VOLUME KNOB	[M]
12	RHD30061-K	SCREW	[M]	41	RHD26016	SCREW	[M]
13	RHR1370ZA	SPACER	[M]	42	RHN90001	NUT	[M]
14	RMN0389	FL. HOLDER	[M]	43	RMAD869	LAMP ORNAMENT	[M]
15	RKA0053-A	FOOT	[M]	44	RSE0006A	METER UNIT	[M]
16	RKQ0089-2	P. C. B. SUPPORT	[M]	45	RGU1436A-K	DOLBY PROLOGIC BUTTON	[M]
17	RMAD977	HOLD ORNAMENT	[M]	46	RGU1437-K	SELECTOR BUTTON	[M]
18	RMCD158	TRANSISTOR HOLDER	[M]	47	SHR9793	SPACER	[M]
19	RMCD272	TUNER EARTH SPRING	[M]	48	SHR9814	CABLE CLIP	[M]
20	RMK0200-3	CHASSIS	[M]	49	XTBS26+8J	SCREW	[M]
21	RMN0217	P. C. B. HOLDER	[M]	50	XTB3+20JFZ	SCREW	[M]
				51	XTB3+6G	SCREW	[M]
				52	RMZ0339	SURGE ABSORBER COVER	[M]

Ref.No.	Part No.	Part Name & Description	Remarks	Ref.No.	Part No.	Part Name & Description	Remarks
		INTEGRATED CIRCUIT(S)		IC1401	TC4W53FTE12L	IC	DM
				IC1402	MB90082PF117	IC	DM
				IC1403	TC7W02FTE12L	IC	DM
IC101	LA1832A	IC	DM	IC1404	LA7213	IC	DM
IC102	LC7218	IC	DM	IC1405	TC4053BF	IC	DM
IC201	TSA3000J	IC	DM			TRANSISTOR(S)	
IC301	TC9162N	IC	DM	Q101	2SC2787L	TRANSISTOR	DM
IC350	BA6138	IC	DM	Q103, 104	2SC2785FE	TRANSISTOR	DM
IC351	M5218AP	IC	DM	Q106	UN411FTA	TRANSISTOR	DM
IC401	TC9163N	IC	DM	Q107, 108	2SC3311AR	TRANSISTOR	DM
IC402	TC9164N	IC	DM	Q191-193	2SC3311AR	TRANSISTOR	DM (E, EB)
IC403	UPC4570C	IC	DM	Q201	UN4119	TRANSISTOR	DM
IC404	AN78L05TA	IC	DM Δ	Q301	UN4213AITA	TRANSISTOR	DM
IC405	AN79L05	IC	DM Δ	Q550	UN4113	TRANSISTOR	DM
IC450	BA6218	IC	DM	Q551	UN4213AITA	TRANSISTOR	DM
IC501	UPC4570C	IC	DM	Q553-558	2SD1915FTA	TRANSISTOR	DM
IC502	TC9184P	IC	DM	Q559	UN4115	TRANSISTOR	DM
IC503	M5218AP	IC	DM	Q601	UN4213AITA	TRANSISTOR	DM
IC601-603	M5218AP	IC	DM	Q701, 702	2SD2374PQAU	TRANSISTOR	DM Δ
IC604-606	CS3310-KP	IC	DM	Q703	2SC3311A-Q	TRANSISTOR	DM Δ
IC607, 608	M5218AP	IC	DM	Q705	2SB621A-R	TRANSISTOR	DM Δ
IC801, 802	RSN3655A	IC	DM Δ	Q706	2SC3940AQSTA	TRANSISTOR	DM Δ
IC803	RSN33M5	IC	DM Δ	Q708	2SB1548PQAU	TRANSISTOR	DM Δ
IC901	LC8A028B5C46	IC	DM	Q709	2SD2374PQAU	TRANSISTOR	DM Δ
IC902	BU2092F	IC	DM	Q710	2SC3311A-Q	TRANSISTOR	DM Δ
IC903	TC4053BF	IC	DM	Q711	2SA1309A-R	TRANSISTOR	DM Δ
IC1101	NJM2115MT1	IC	DM	Q712	2SC3311A-Q	TRANSISTOR	DM Δ
IC1102	NJM2115MT1	IC	DM	Q713	2SA1309A-R	TRANSISTOR	DM Δ
IC1103	AK5340B-VS	IC	DM	Q714	2SC3940AQSTA	TRANSISTOR	DM Δ
IC1104	TC9332F-022	IC	DM	Q715	UN4219TA	TRANSISTOR	DM
IC1106	AK4320-VM	IC	DM	Q716-718	2SA1309A-R	TRANSISTOR	DM
IC1107	AK4320-VM	IC	DM	Q719	2SA1534AQRTA	TRANSISTOR	DM
IC1108	AK4320-VM	IC	DM	Q720, 721	2SA1309A-R	TRANSISTOR	DM
IC1109	NJM2115MT1	IC	DM	Q801-804	2SD1915FTA	TRANSISTOR	DM
IC1110	NJM2115MT1	IC	DM	Q805	DTC143ESTP	TRANSISTOR	DM
IC1111	NJM2115MT1	IC	DM	Q806	UN4113	TRANSISTOR	DM
IC1112	TC7W74FTE12L	IC	DM	Q807	UN4211	TRANSISTOR	DM
IC1113	TC7W004FT12L	IC	DM	Q808	UN4113	TRANSISTOR	DM
IC1114	LM2940T5	IC	DM Δ	Q810-812	UN4210-S	TRANSISTOR	DM
IC1115	LM2940T5	IC	DM Δ	Q813	2SA1309A-R	TRANSISTOR	DM
IC1116	TC7W74FTE12L	IC	DM	Q814	2SC3311A-Q	TRANSISTOR	DM
IC1117	TC7S04FTE85L	IC	DM	Q815	2SA1309A-R	TRANSISTOR	DM
IC1118	TC74HC164AFL	IC	DM	Q816	2SC3311A-Q	TRANSISTOR	DM
IC1119	TC7S32FTE85L	IC	DM	Q817	2SA1309A-R	TRANSISTOR	DM
IC1301	BA7625	IC	DM	Q818	2SC3311A-Q	TRANSISTOR	DM
IC1302	BA7625	IC	DM				
IC1303	BA7625	IC	DM				

Ref. No.	Part No.	Part Name & Description	Remarks	Ref. No.	Part No.	Part Name & Description	Remarks
Q819	2SA1309A-R	TRANSISTOR	[M]	D805-814	MA167	DIODE	[M]
Q820	2SC3311A-Q	TRANSISTOR	[M]	D816-821	MA167	DIODE	[M]
Q821	2SA1309A-R	TRANSISTOR	[M]	D822	MA4056MTA	DIODE	[M]
Q822	2SC3311A-Q	TRANSISTOR	[M]	D823-828	SB360L6508	DIODE	[M]
Q831-834	UN4119	TRANSISTOR	[M]	D829-833	MA165	DIODE	[M]
Q837-841	2SC3311A-Q	TRANSISTOR	[M]	D834	MA167	DIODE	[M]
Q901	2SA1309A-R	TRANSISTOR	[M]	D835-837	MA165	DIODE	[M]
Q902	2SA1309A-R	TRANSISTOR	[M] Δ	D901, 902	MA165	DIODE	[M]
Q903	UN4214TA	TRANSISTOR	[M]	D903	MA4056MTA	DIODE	[M] Δ
Q904	UN4111	TRANSISTOR	[M]	D904	MA4039MTA	DIODE	[M] Δ
Q905	UN4211	TRANSISTOR	[M]	D908	MA165	DIODE	[M]
Q906	UN4216-S	TRANSISTOR	[M]	D909	MA165	DIODE	[M] (EG)
Q907	UN4113	TRANSISTOR	[M]	D910	MA165	DIODE	[M] (E, EB)
Q908, 909	UN4213AITA	TRANSISTOR	[M]	D913	MA165	DIODE	[M]
Q910	UN4113	TRANSISTOR	[M]	D914, 915	1SS291TA	DIODE	[M]
Q1101	UN4213AITA	TRANSISTOR	[M]	D916-922	SLR-325VC	L. E. D.	[M]
Q1301-1306	2SA1309A-R	TRANSISTOR	[M]	D923	MA4062MTA	DIODE	[M]
Q1401, 1402	2SC3311A-Q	TRANSISTOR	[M]	D925, 926	MA165	DIODE	[M]
Q1403	UN4111	TRANSISTOR	[M]	D927	MA4030MTA	DIODE	[M]
Q1404, 1405	2SC3311A-Q	TRANSISTOR	[M]	D928	MA165	DIODE	[M]
Q1406, 1407	2SA1309A-R	TRANSISTOR	[M]	D1401-1405	MA165	DIODE	[M]
Q1408	2SC3311A-Q	TRANSISTOR	[M]				
Q1409	2SA1309A-R	TRANSISTOR	[M]			IC PROTECTOR(S)	
Q1410, 1411	2SC3311A-Q	TRANSISTOR	[M]				
Q1412	UN4213AITA	TRANSISTOR	[M]	ICP701	SRUN10	IC PROTECTOR	[M] Δ
		DIODE(S)				VARIABLE RESISTOR(S)	
D101	MA4051MTA	DIODE	[M] Δ	VR350, 351	EVNDXAA00B23	V. R	[M]
D102	MA165	DIODE	[M]	VR450	ELWWR9F251J9	V. R	[M]
D351-359	MA165	DIODE	[M]	VR901, 902	EVJ02KF02B24	V. R	[M]
D401	MA4062MTA	DIODE	[M]				
D550	MA165	DIODE	[M]			THERMISTOR(S)	
D554	MA165	DIODE	[M]				
D555, 556	MA700	DIODE	[M]	TH350, 351	ERTD2ZHL104T	THERMISTOR	[M]
D601	MA165	DIODE	[M]				
D701	MA4030MTA	DIODE	[M] Δ			COIL(S)	
D704	MA4220MTA	DIODE	[M] Δ				
D705	MA4062MTA	DIODE	[M] Δ	L101	ELESNR68MA	COIL	[M] (E, EB)
D708	MA4062	DIODE	[M] Δ	L101	ELESN1R0MA	COIL	[M] (EG)
D709-712	1SR35200TB	DIODE	[M] Δ	L103	ELEXTR47MA9	COIL	[M]
D713, 714	SVDS10VB20F	DIODE	[M] Δ	L105, 106	RLQZB822KT-D	COIL	[M]
D715	MA4068M	DIODE	[M] Δ	L151	SLM1B10M-1M	COIL	[M]
D716	MA165	DIODE	[M]	L191	ELESNR68MA	COIL	[M] (E, EB)
D717-720	1SR35200TB	DIODE	[M] Δ	L191	ELESNR56MA	COIL	[M] (EG)
D721	MA165	DIODE	[M]	L450, 451	RLQZP1R0KT-Y	COIL	[M]
D722	MA4068L	DIODE	[M]	L801-603	RLQZP101KT-Y	COIL	[M]
D723	MA165	DIODE	[M]	L701	ELEPK101KA	COIL	[M]
D725-728	1SR35200TB	DIODE	[M] Δ	L751	SLQZ850MH49	COIL	[M] Δ
D801	MA4075MTA	DIODE	[M] Δ	L801-805	SLQY07G-40	COIL	[M]
D802, 803	MA4030MTA	DIODE	[M] Δ	L901	RLQZP1R8KT-Y	COIL	[M]
D804	MA4062MTA	DIODE	[M]	L902	RLQZP101KT-Y	COIL	[M]

Ref. No.	Part No.	Part Name & Description	Remarks	Ref. No.	Part No.	Part Name & Description	Remarks
L1101, 1102	RLQZB8R2KT-D	COIL	[M]			FUSE (S)	
L1103-1106	RLQZP100KT-Y	COIL	[M]				
L1107-1112	RLQZP1R2KT-Y	COIL	[M]	F1	XBA2C31T80	FUSE, 250V, T3. 15A	[M]△
L1113	RLQZP1R8KT-Y	COIL	[M]	F2, 3	XBA2C63T80	FUSE, 250V, T6. 3A	[M]△
L1115, 1116	RLQZP1R8KT-Y	COIL	[M]	F4	XBA2C25T80	FUSE, 250V, T2. 5A	[M]△
L1118, 1119	RLQZP1R8KT-Y	COIL	[M]				
L1121, 1122	RLQZP1R8KT-Y	COIL	[M]			FM FRONT END PACK ASS'Y (S)	
L1124	RLQZP1R8KT-Y	COIL	[M]				
L1125, 1126	RLQZB101KT-D	COIL	[M]	Z120	ENV17290G1Y	FM FRONT END	[M]
L1127, 1128	RLQZP1R8KT-Y	COIL	[M]				
L1130-1133	RLQZP1R8KT-Y	COIL	[M]			SWITCH(ES)	
L1135	RLQZP1R2KT-Y	COIL	[M]				
L1401	RLQZP220KT-Y	COIL	[M]	S901-922	EVQ21405R	SW	[M]
L1402	RLQZB101KT-D	COIL	[M]				
L1403	RLQZP101KT-Y	COIL	[M]			RELAY (S)	
L1404	RLQZB101KT-D	COIL	[M]				
L1405-1410	RLQZP1R8KT-Y	COIL	[M]	RL701	RSY0019-0	RELAY	[M]△
				RL801-804	RSY0013M-0	RELAY	[M]△
		TRANSFORMER (S)				CONNECTOR(S) AND SOCKET(S)	
T701	RTP115E006	POWER TRANSFORMER	[M]△				
T702	RTP1P5B008-W	POWER TRANSFORMER	[M]△				
		COMPONENT COMBINATION (S)					
Z101	RLA6Z005M-T	COMPONENT COMBINATION	[M] (E, EB)	CN101	RJU057W007	SOCKET (7P)	[M]
Z101	RLA2Z002M-T	COMPONENT COMBINATION	[M] (EG)	CN101A	RJT057W007-1	CONNECTOR (7P)	[M]
Z102	RLI2Z006M-T	COMPONENT COMBINATION	[M]	CN102	RJU057W007	SOCKET (7P)	[M]
Z401	BL02R2R2R65T2	COMPONENT COMBINATION	[M]	CN102A	RJT057W007-1	CONNECTOR (7P)	[M]
Z701	ERZV10V511CS	SURGE ABSORBER	[M]△	CN201	SJT30345JQ	CONNECTOR (3P)	[M]
Z901	RCDHG-278N	REMOTE SENSOR	[M]	CN201A	SJS50382JQH	CONNECTOR (3P)	[M]
Z1122-1126	BL02R2R2R65T2	COMPONENT COMBINATION	[M]	CN202	RJP5G17ZA	CONNECTOR (5P)	[M]
		FILTER(S) AND OSCILLATOR(S)		CN301	SJT3513	CONNECTOR (5P)	[M]
				CN401	SJT3417	CONNECTOR (4P)	[M]
CF201	RLFFETNGD01L	FILTER	[M]	CN650	RJT003K008-1	CONNECTOR (8P)	[M]
CF202	RLFFETNGD01L	FILTER	[M]	CN650A	RJU003K008M1	SOCKET (8P)	[M]
CF901	EFOEC6004T4	OSCILLATOR	[M]	CN701	RJS1A6605	CONNECTOR (5P)	[M]
X101	RSX2456K07M	OSCILLATOR	[M]	CN702A	RJS1A6604	CONNECTOR (4P)	[M]
X102	RLFDGTD01I	OSCILLATOR	[M]	CN702B	RJS1A6603	CONNECTOR (3P)	[M]
X103	RSXC7M20S05T	OSCILLATOR	[M]	CN703	RJS1A6604	CONNECTOR (4P)	[M]
X1101	RSXC22M5S01T	OSCILLATOR	[M]	CN706	RJS1A6606	CONNECTOR (6P)	[M]
X1401	RSXC17M7S01	OSCILLATOR	[M]	CN707A	RJS1A6605	CONNECTOR (5P)	[M]
		DISPLAY TUBE		CN707B	RJS1A6605	CONNECTOR (5P)	[M]
FL901	RSL0224-F	DISPLAY TUBE	[M]	CN717	SJS305-1	CONNECTOR (3P)	[M]
		LAMP (S)		CN728	RJS1A7402-1	CONNECTOR (2P)	[M]
PL200-209	XAMR131	LAMP	[M]	CN751-759	RJS1A1101T1	CONNECTOR (1P)	[M]
				CN802	RJT057W007-1	CONNECTOR (7P)	[M]
				CN802A	RJU057W007	SOCKET (7P)	[M]
				CN803	RJT057W007-1	CONNECTOR (7P)	[M]
				CN803A	RJU057W007	SOCKET (7P)	[M]
				CN804	RJT057W007-1	CONNECTOR (7P)	[M]
				CN804A	RJU057W007	SOCKET (7P)	[M]
				CN809	RJU003K008M1	SOCKET (8P)	[M]
				CN809A	RJT003K008-1	CONNECTOR (8P)	[M]
				CN810	RJU003K008M1	SOCKET (8P)	[M]
				CN810A	RJT003K008-1	CONNECTOR (8P)	[M]

Ref. No.	Part No.	Part Name & Description	Remarks	Ref. No.	Part No.	Part Name & Description	Remarks
CN811	RJU003K008M1	SOCKET (8P)	[M]	JK1303	SJF3068-2N	VCR1 IN/OUT (VIDEO)	[M]
CN811A	RJT003K008-1	CONNECTOR (8P)	[M]	JK1401	RJS1D1104	VCR1/TV MONITOR (S-VIDEO)	[M]
CN812	RJT057W007-1	CONNECTOR (7P)	[M]	JK1402	RJS1D1104	VCR1/VDP IN (S-VIDEO)	[M]
CN812A	RJU057W007	SOCKET (7P)	[M]			GND PLATE(S)	
CN813	RJU003K008M1	SOCKET (8P)	[M]				
CN813A	RJT003K008-1	CONNECTOR (8P)	[M]	E801, 802	SNE1004-2	GND PLATE	[M]
CN814	RJU003K008M1	SOCKET (8P)	[M]	E803	RMA0824	GND PLATE	[M]
CN814A	RJT003K008-1	CONNECTOR (8P)	[M]				
CN815	RJT057W007-1	CONNECTOR (7P)	[M]			FUSE HOLDER(S)	
CN815A	RJU057W007	SOCKET (7P)	[M]				
CN816	RJT057W004-1	CONNECTOR (4P)	[M]				
CN816A	RJU057W004	SOCKET (4P)	[M]	FC701-708	EYF52BC	FUSE HOLDER	[M]
CN820	RJU060G07T	SOCKET (7P)	[M]				
CN820A	RJT060R07	CONNECTOR (7P)	[M]				
CN821	RJU060G07T	SOCKET (7P)	[M]				
CN821A	RJT060R07	CONNECTOR (7P)	[M]				
CN907	RJS1A6606	CONNECTOR (6P)	[M]				
CN909	RJS1A6606	CONNECTOR (6P)	[M]				
CN911	RJS1A6605	CONNECTOR (5P)	[M]				
CN915	RJS1A6604	CONNECTOR (4P)	[M]				
CN917	RJS1A6606	CONNECTOR (6P)	[M]				
CN1101A	SJT3613	CONNECTOR (6P)	[M]				
CN1101B	RJT029W03VT	CONNECTOR (3P)	[M]				
CN1102A	SJT3909	CONNECTOR (9P)	[M]				
CN1103	SJT3809	CONNECTOR (8P)	[M]				
CN1306	SJT3321	CONNECTOR (3P)	[M]				
CN1307	RJU057W007	SOCKET (7P)	[M]				
CN1307A	RJT057W007-1	CONNECTOR (7P)	[M]				
CN1308	RJT057W007-1	CONNECTOR (7P)	[M]				
CN1308A	RJU057W007	SOCKET (7P)	[M]				
CN1309	RJT057W007-1	CONNECTOR (7P)	[M]				
CN1309A	RJU057W007	SOCKET (7P)	[M]				
CN1405	RJU057W007	SOCKET (7P)	[M]				
CN1405A	RJT057W007-1	CONNECTOR (7P)	[M]				
		JACK(S) AND TERMINAL(S)					
HP818	RJG3TA01	HEADPHONES JACK	[M]				
JK101	RJH4202M	ANT TERMINAL	[M]				
JK301	SJF3069-13N	VDP 6CH IN (AUDIO)	[M]				
JK401	SJF3069-5N	CD IN, TAPE REC OUT (AUDIO)	[M]				
JK402	SJF3069N	VCR/OUT, TAPE PLAY IN (AUDIO)	[M]				
JK403	SJF3069N	VCR/IN, VCR2 IN (AUDIO)	[M]				
JK404	SJF3069N	VDP/VDP 6CH/TV IN (AUDIO)	[M]				
JK405	SJFK5-1	VCR3 AUDIO/IN	[M]				
JK703	SJS9236	AC INLET	[M] Δ				
JK805	SJFD7	SUBWOOFER	[M]				
JK807	RJH4601-1	FRONT SPEAKERS	[M]				
JK808	RJH4203A	CENTER SPEAKERS	[M]				
JK809	RJH4406	SURROUND SPEAKERS	[M]				
JK1301	SJFD7-5	TV IN (VIDEO)	[M]				
JK1302	SJF3069-12N	VCR2/VDP IN, TV MONI. (VIDEO)	[M]				

Resistors and Capacitors

Notes: * Capacity values are in microfarads (μF) unless specified otherwise, P=Pico-farads (pF) F=Farads (F)
 * Resistance values are in ohms, unless specified otherwise, 1K=1,000 (OHM), 1M=1,000k (OHM)
 * [M] indicates in Remarks columns parts that are supplied by MESA.

Ref. No.	Part No.	Values & Remarks	Ref. No.	Part No.	Values & Remarks	Ref. No.	Part No.	Values & Remarks
		RESISTORS	R310-312	ERDS2TJ103	1/4W 10K [M]	R521, 522	ERDS2TJ223	1/4W 22K [M]
			R313, 314	ERDS2TJ102	1/4W 1K [M]	R523, 524	ERDS2TJ152	1/4W 1.5K [M]
			R315, 316	ERDS2TJ103	1/4W 10K [M]	R525, 526	ERDS2TJ102	1/4W 1K [M]
R103	ERDS2TJ101	1/4W 100 [M]	R317, 318	ERDS2TJ332	1/4W 3.3K [M]	R527, 528	ERDS2TJ123	1/4W 12K [M]
R104	ERDS2TJ102	1/4W 1K [M]	R319, 320	ERDS2TJ822	1/4W 8.2K [M]	R529, 530	ERDS2TJ223	1/4W 22K [M]
R105	ERDS2TJ471	1/4W 470 [M]	R321, 322	ERDS2TJ153	1/4W 15K [M]	R531, 532	ERDS2TJ473	1/4W 47K [M]
R106	ERDS2TJ224T	1/4W 220K [M]	R323	ERDS2TJ103	1/4W 10K [M]	R550	ERDS2TJ822	1/4W 8.2K [M]
R107	ERDS2TJ471	1/4W 470 [M]	R324	ERDS2TJ682T	1/4W 6.8K [M]	R551, 552	ERDS2TJ472	1/4W 4.7K [M]
R110	ERDS2TJ102	1/4W 1K [M]	R350	ERDS2TJ103	1/4W 10K [M]	R553	ERDS2TJ824	1/4W 820K [M]
R112	ERDS2TJ104	1/4W 100K [M]	R351	ERDS1FVJ101T	1/2W 100 [M] Δ	R554	ERDS2TJ102	1/4W 1K [M]
R113	ERDS2TJ103	1/4W 10K [M]	R352	ERDS2TJ155	1/4W 1.5M [M]	R557	ERDS2TJ103	1/4W 10K [M]
R114	ERDS2TJ562	1/4W 5.6K [M]	R353	ERDS2TJ331	1/4W 330 [M]	R561-566	ERDS2TJ471	1/4W 470 [M]
R115	ERDS2TJ561	1/4W 560 [M]	R354	ERDS2TJ104	1/4W 100K [M]	R567-572	ERDS2TJ102	1/4W 1K [M]
R116	ERDS2TJ102	1/4W 1K [M]	R355	ERDS2TJ331	1/4W 330 [M]	R573-578	ERDS2TJ823T	1/4W 82K [M]
R117	ERDS2TJ473	1/4W 47K [M]	R356	ERDS2TJ155	1/4W 1.5M [M]	R601-606	ERDS2TJ102	1/4W 1K [M]
R118	ERDS2TJ562	1/4W 5.6K [M]	R357, 358	ERDS2TJ682T	1/4W 6.8K [M]	R607, 608	ERDS2TJ273	1/4W 27K [M]
R119	ERDS2TJ183T	1/4W 18K [M]	R359, 360	ERDS2TJ103	1/4W 10K [M]	R609-612	ERDS2TJ104	1/4W 100K [M]
R120	ERDS2TJ473	1/4W 47K [M]	R361, 362	ERDS2TJ821	1/4W 820 [M]	R615-617	ERDS2TJ102	1/4W 1K [M]
R121	ERDS2TJ332	1/4W 3.3K [M]	R363	ERDS2TJ223	1/4W 22K [M]	R618	ERDS2TJ152	1/4W 1.5K [M]
R122	ERDS2TJ272T	1/4W 2.7K [M]	R364	ERDS2TJ102	1/4W 1K [M]	R619	ERDS2TJ272T	1/4W 2.7K [M]
R124	ERDS2TJ271	1/4W 270 [M]	R365	ERDS2TJ223	1/4W 22K [M]	R620	ERDS2TJ392T	1/4W 3.9K [M]
R125, 126	ERDS2TJ472	1/4W 4.7K [M]	R366	ERDS2TJ102	1/4W 1K [M]	R623	ERDS1FVJ101T	1/2W 100 [M] Δ
R127	ERDS2TJ103	1/4W 10K [M]	R367, 368	ERDS2TJ681	1/4W 680 [M]	R624	ERDS1FVJ221T	1/2W 220 [M] Δ
R128	ERDS2TJ820	1/4W 82 [M]	R369	ERDS2TJ154	1/4W 150K [M]	R625-630	ERDS2TJ104	1/4W 100K [M]
R129	ERDS2TJ473	1/4W 47K [M]	R370	ERDS1FVJ101T	1/2W 100 [M] Δ	R631-633	ERGISJ100	1W 10 [M]
R130, 131	ERDS2TJ102	1/4W 1K [M]	R371	ERDS2TJ154	1/4W 150K [M]	R635	ERDS2TJ102	1/4W 1K [M]
R132	ERDS2TJ103	1/4W 10K [M]	R372, 373	ERDS2TJ123	1/4W 12K [M]	R636	ERDS2TJ152	1/4W 1.5K [M]
R133-137	ERDS2TJ102	1/4W 1K [M]	R401-420	ERDS2TJ102	1/4W 1K [M]	R637	ERDS2TJ104	1/4W 100K [M]
R139, 140	ERDS2TJ272T	1/4W 2.7K [M]	R421-426	ERDS2TJ103	1/4W 10K [M]	R638	ERDS2TJ823T	1/4W 82K [M]
R141, 142	ERDS2TJ102	1/4W 1K [M]	R427, 428	ERDS2TJ471	1/4W 470 [M]	R639, 640	ERDS2TJ473	1/4W 47K [M]
R143, 144	ERDS2TJ222	1/4W 2.2K [M]	R429, 430	ERDS2TJ473	1/4W 47K [M]	R641, 642	ERDS2TJ104	1/4W 100K [M]
R145, 146	ERDS2TJ102	1/4W 1K [M] (E, EB)	R431, 432	ERDS2TJ104	1/4W 100K [M]	R643	ERDS2TJ152	1/4W 1.5K [M]
R145, 146	ERDS2TJ561T	1/4W 560 [M] (EG)	R434, 435	ERDS2TJ102	1/4W 1K [M]	R644	ERDS2TJ123	1/4W 12K [M]
R147, 148	ERDS2TJ474	1/4W 470K [M]	R437, 438	ERDS2TJ224T	1/4W 220K [M]	R645	ERDS2TJ102	1/4W 1K [M]
R149	ERDS2TJ680T	1/4W 68 [M]	R439	ERDS2TJ471	1/4W 470 [M]	R646	ERDS2TJ152	1/4W 1.5K [M]
R171, 172	ERDS2TJ102	1/4W 1K [M]	R450	ERDS2TJ104	1/4W 100K [M]	R647, 648	ERDS2TJ102	1/4W 1K [M]
R173	ERDS2TJ471	1/4W 470 [M]	R451	ERDS1FVJ2R2T	1/2W 2.2 [M] Δ	R649, 650	ERDS2TJ152	1/4W 1.5K [M]
R175	ERDS2TJ102	1/4W 1K [M]	R452	ERDS2TJ562	1/4W 5.6K [M]	R651, 652	ERDS2TJ102	1/4W 1K [M]
R176	ERDS2TJ391	1/4W 390 [M]	R453	ERDS2TJ103	1/4W 10K [M]	R653	ERDS2TJ473	1/4W 47K [M]
R191	ERDS2TJ103	1/4W 10K [M] (E, EB)	R501, 502	ERDS2TJ271	1/4W 270 [M]	R657, 658	ERDS2TJ102	1/4W 1K [M]
R192	ERDS2TJ122	1/4W 1.2K [M] (E, EB)	R503, 504	ERDS2TJ182	1/4W 1.8K [M]	R659-662	ERDS2TJ154	1/4W 150K [M]
R193	ERDS2TJ182	1/4W 1.8K [M] (E, EB)	R505, 506	ERDS2TJ474	1/4W 470K [M]	R663	ERDS2TJ103	1/4W 10K [M]
R194	ERDS2TJ122	1/4W 1.2K [M] (E, EB)	R507, 508	ERDS2TJ332	1/4W 3.3K [M]	R701	ERDS1FJ1R0	1/2W 1.0 [M] Δ
R195	ERDS2TJ222	1/4W 2.2K [M] (E, EB)	R509, 510	ERDS2TJ333	1/4W 33K [M]	R702, 703	ERDS2FJ1R8	1/4W 1.8 [M]
R202	ERDS1FVJ101T	1/2W 100 [M] Δ	R511, 512	ERDS2TJ243T	1/4W 24K [M]	R706	ERDS2TJ681	1/4W 680 [M]
R203	ERDS2TJ101	1/4W 100 [M]	R513, 514	ERDS2TJ562	1/4W 5.6K [M]	R707	ERDS2TJ122	1/4W 1.2K [M]
R204	ERDS2TJ271	1/4W 270 [M]	R515, 516	ERDS2TJ681	1/4W 680 [M]	R708	ERDS2TJ222	1/4W 2.2K [M]
R205, 206	ERDS2TJ103	1/4W 10K [M]	R517, 518	ERDS2TJ224T	1/4W 220K [M]	R709	ERDS2TJ682T	1/4W 6.8K [M]
R301	ERDS2TJ224T	1/4W 220K [M]	R519, 520	ERDS2TJ392T	1/4W 3.9K [M]	R710	ERDS2TJ102	1/4W 1K [M]

Ref. No.	Part No.	Values & Remarks	Ref. No.	Part No.	Values & Remarks	Ref. No.	Part No.	Values & Remarks
R712	ERDS2TJ332	1/4W 3.3K [M]	R853	ERDS2TJ393	1/4W 39K [M]	R935	ERDS2TJ472	1/4W 4.7K [M]
R713	ERDS1FVJ681T	1/2W 680 [M]△	R854, 855	ERDS2TJ473	1/4W 47K [M]	R936	ERDS2TJ681	1/4W 680 [M]
R714	ERDS2FJ3R3	1/4W 3.3 [M]△	R856	ERDS2TJ222	1/4W 2.2K [M]	R937	ERDS2TJ103	1/4W 10K [M]
R715	ERDS2TJ182	1/4W 1.8K [M]	R857	ERDS2TJ102	1/4W 1K [M]	R938-940	ERDS2TJ104	1/4W 100K [M]
R716	ERDS1FVJ681T	1/2W 680 [M]△	R858-860	ERDS2TJ473	1/4W 47K [M]	R941	ERDS2TJ182	1/4W 1.8K [M]
R717	ERDS1FJ1R0	1/2W 1.0 [M]△	R862	ERDS2TJ105T	1/4W 1M [M]	R942	ERDS2TJ222	1/4W 2.2K [M]
R718	ERDS2TJ273	1/4W 27K [M]	R863	ERDS2FJ122	1/4W 1.2K [M]△	R943	ERDS2TJ332	1/4W 3.3K [M]
R719	ERDS2TJ222	1/4W 2.2K [M]	R865	ERDS2FJ122	1/4W 1.2K [M]△	R944, 945	ERDS2TJ102	1/4W 1K [M]
R720	ERDS2TJ273	1/4W 27K [M]	R866	ERDS2TJ473	1/4W 47K [M]	R946	ERDS2TJ182	1/4W 1.8K [M]
R722	ERDS2FJ752	1/4W 7.5K [M]	R867, 868	ERDS2TJ393	1/4W 39K [M]	R947	ERDS2TJ222	1/4W 2.2K [M]
R723	ERDS2TJ682T	1/4W 6.8K [M]	R870, 871	ERDS2TJ102	1/4W 1K [M]	R948	ERDS2TJ332	1/4W 3.3K [M]
R724	ERDS1FVJ681T	1/2W 680 [M]△	R872-874	ERDS2FJ122	1/4W 1.2K [M]△	R949	ERDS2TJ472	1/4W 4.7K [M]
R726	ERDS2TJ472	1/4W 4.7K [M]	R875-877	ERDS2TJ393	1/4W 39K [M]	R950	ERDS2TJ471	1/4W 470 [M]
R727, 728	ERDS2TJ221	1/4W 220 [M]	R878	ERDS2TJ102	1/4W 1K [M]	R951	ERDS2TJ472	1/4W 4.7K [M]
R729, 730	ERDS2TJ102	1/4W 1K [M]	R879	ERDS2TJ184T	1/4W 180K [M]	R952, 953	ERDS2TJ102	1/4W 1K [M]
R731, 732	ERDS2TJ472	1/4W 4.7K [M]	R880	ERDS2TJ102	1/4W 1K [M]	R954	ERDS2TJ103	1/4W 10K [M]
R733, 734	ERDS1FVJ3R3T	1/2W 3.3 [M]△	R881	ERDS1FVJ220T	1/2W 22 [M]△	R955	ERDS2TJ192	1/4W 1.8K [M]
R735	ERX1SR22E	1W 0.22 [M]	R882	ERDS2TJ102	1/4W 1K [M]	R956	ERDS2TJ222	1/4W 2.2K [M]
R736, 737	ERDS2TJ333	1/4W 33K [M]	R883	ERDS2TJ473	1/4W 47K [M]	R957	ERDS2TJ332	1/4W 3.3K [M]
R738	ERX1SR22E	1W 0.22 [M]	R884	ERDS2TJ684	1/4W 680K [M]	R961	ERDS2TJ224T	1/4W 220K [M]
R739	ERDS2TJ102	1/4W 1K [M]	R885	ERDS2TJ104	1/4W 100K [M]	R962	ERDS2TJ103	1/4W 10K [M]
R740	ERDS2TJ682T	1/4W 6.8K [M]	R886	ERDS2TJ123	1/4W 12K [M]	R964-966	ERDS2TJ104	1/4W 100K [M]
R741	ERDS2TJ104	1/4W 100K [M]	R887	ERDS2TJ102	1/4W 1K [M]	R967	ERDS2TJ103	1/4W 10K [M]
R742	ERDS2TJ103	1/4W 10K [M]	R888	ERDS2TJ123	1/4W 12K [M]	R968	ERDS2TJ102	1/4W 1K [M]
R743	ERDS2TJ335T	1/4W 3.3M [M]	R889-893	ERDS1FVJ470T	1/2W 47 [M]△	R969	ERDS2TJ122	1/4W 1.2K [M]
R744	ERDS2TJ223	1/4W 22K [M]	R894	ERDS1FVJ100T	1/2W 10 [M]△	R970	ERDS2TJ152	1/4W 1.5K [M]
R745	ERDS2TJ270T	1/4W 27 [M]	R895, 896	ERGSJ680	1W 68 [M]	R971	ERDS2TJ103	1/4W 10K [M]
R746	ERDS2TJ472	1/4W 4.7K [M]	R897, 898	ERDS1FVJ100T	1/2W 10 [M]△	R972	ERDS2TJ102	1/4W 1K [M]
R748	ERDS2TJ103	1/4W 10K [M]	R899	ERDS2TJ124T	1/4W 120K [M]	R973	ERDS2TJ122	1/4W 1.2K [M]
R749	ERDS2TJ153	1/4W 15K [M]	R901	ERDS2TJ181T	1/4W 180 [M]	R974	ERDS2TJ152	1/4W 1.5K [M]
R750, 751	ERDS2TJ473	1/4W 47K [M]	R903	ERDS2TJ222	1/4W 2.2K [M]	R975	ERDS2TJ103	1/4W 10K [M]
R752	ERDS2TJ103	1/4W 10K [M]	R904	ERDS2TJ562	1/4W 5.6K [M]	R976	ERDS2TJ102	1/4W 1K [M]
R753	ERDS2TJ222	1/4W 2.2K [M]	R905	ERDS2TJ122	1/4W 1.2K [M]	R977	ERDS2TJ122	1/4W 1.2K [M]
R754	ERDS2TJ220T	1/4W 22 [M]	R906	ERDS2TJ103	1/4W 10K [M]	R978	ERDS2TJ152	1/4W 1.5K [M]
R755	ERDS2TJ222	1/4W 2.2K [M]	R907, 908	ERDS2TJ102	1/4W 1K [M]	R979	ERDS2TJ102	1/4W 1K [M]
R758	ERDS1FJ1R0	1/2W 1.0 [M]△	R909-911	ERDS2TJ104	1/4W 100K [M]	R980	ERDS2TJ222	1/4W 2.2K [M]
R801-806	ERDS2TJ223	1/4W 22K [M]	R912	ERDS2TJ473	1/4W 47K [M]	R981	ERDS2TJ822	1/4W 8.2K [M]
R807-811	ERDS2TJ102	1/4W 1K [M]	R914, 915	ERDS2TJ104	1/4W 100K [M]	R982, 983	ERDS2TJ472	1/4W 4.7K [M]
R813	ERDS2TJ224T	1/4W 220K [M]	R916	ERDS2TJ101	1/4W 100 [M]	R984	ERDS2TJ822	1/4W 8.2K [M]
R814, 815	ERDS2TJ182	1/4W 1.8K [M]	R917	ERDS2TJ562	1/4W 5.6K [M]	R987	ERDS2TJ102	1/4W 1K [M]
R817	ERDS2TJ224T	1/4W 220K [M]	R918-922	ERDS2TJ102	1/4W 1K [M]	R1000	ERDS2TJ223	1/4W 22K [M]
R818, 819	ERDS2TJ821	1/4W 820 [M]	R923	ERDS2TJ101	1/4W 100 [M]	R1003	ERDS1FJ820	1/2W 82 [M]△
R822, 823	ERDS2TJ391	1/4W 390 [M]	R924	ERDS2TJ102	1/4W 1K [M]	R1004, 1005	ERDS2TJ102	1/4W 1K [M]
R825, 826	ERDS2TJ152	1/4W 1.5K [M]	R925	ERDS2TJ101	1/4W 100 [M]	R1006	ERDS2TJ330	1/4W 33 [M]
R827	ERDS2TJ221	1/4W 220 [M]	R926	ERDS2TJ102	1/4W 1K [M]	R1007, 1008	ERDS2TJ473	1/4W 47K [M]
R830	ERDS2EJ121	1/4W 120 [M]	R927	ERDS2TJ472	1/4W 4.7K [M]	R1009-1011	ERDS2TJ102	1/4W 1K [M]
R831	ERDS2TJ100	1/4W 10 [M]	R928, 929	ERDS2TJ102	1/4W 1K [M]	R1023	ERDS2TJ102	1/4W 1K [M]
R832	ERDS2TJ822	1/4W 8.2K [M]	R930	ERDS2TJ101	1/4W 100 [M]	R1024	ERDS2TJ223	1/4W 22K [M]
R833	ERDS2TJ182	1/4W 1.8K [M]	R931	ERDS2TJ271	1/4W 270 [M]	R1025	ERDS2TJ122	1/4W 1.2K [M]
R834, 835	ERDS2TJ471	1/4W 470 [M]	R932	ERDS2EJ121	1/4W 120 [M]	R1026	ERDS2TJ152	1/4W 1.5K [M]
R846-848	ERDS2TJ471	1/4W 470 [M]	R933	ERDS2TJ104	1/4W 100K [M]	R1027, 1028	ERDS2TJ272T	1/4W 2.7K [M]
R849-852	ERDS2TJ222	1/4W 2.2K [M]	R934	ERDS2TJ102	1/4W 1K [M]	R1029	ERDS2TJ152	1/4W 1.5K [M]

Ref. No.	Part No.	Values & Remarks	Ref. No.	Part No.	Values & Remarks	Ref. No.	Part No.	Values & Remarks
R1030	ERDS2TJ272T	1/4W 2.7K [M]	R1157-1160	ERDS2TJ103	1/4W 10K [M]	R1516	ERDS2TJ102	1/4W 1K [M]
R1031	ERDS1FJ472	1/2W 4.7K [M]△	R1161, 1162	ERDS2TJ822	1/4W 8.2K [M]	R1517	ERDS2TJ682T	1/4W 6.8K [M]
R1032	ERDS2TJ682T	1/4W 6.8K [M]	R1163-1166	ERDS2TJ103	1/4W 10K [M]	R1518, 1519	ERDS2TJ122	1/4W 1.2K [M]
R1033	ERDS2TJ472	1/4W 4.7K [M]	R1167, 1168	ERDS2TJ822	1/4W 8.2K [M]	R1521	ERDS2TJ103	1/4W 10K [M]
R1034	ERDS1FJ472	1/2W 4.7K [M]△	R1169-1172	ERDS2TJ104	1/4W 100K [M]			
R1035	ERDS2TJ682T	1/4W 6.8K [M]	R1173-1175	ERDS2TJ100	1/4W 10 [M]			CAPACITORS
R1036	ERDS2TJ472	1/4W 4.7K [M]	R1176	ERDS2TJ152	1/4W 1.5K [M]	C101	ECBT1C103NS5	16V 0.01U [M]
R1037, 1038	ERG1SJ680	1W 68 [M]	R1179-1188	ERDS2TJ102	1/4W 1K [M]	C103	ECBT1C103NS5	16V 0.01U [M]
R1039, 1040	ERDS1FVJ100T	1/2W 10 [M]△	R1301-1311	ERDS2TJ750	1/4W 75 [M]	C104	ECBT1H102KB5	50V 1000P [M]
R1041, 1042	ERDS2TJ222	1/4W 2.2K [M]	R1312	ERDS2TJ101	1/4W 100 [M]	C105	ECBT1H220JC5	50V 22P [M]
R1043	ERDS2TJ682T	1/4W 6.8K [M]	R1313, 1314	ERDS2TJ221	1/4W 220 [M]	C106	ECBT1C103NS5	16V 0.01U [M]
R1044	ERDS2TJ154	1/4W 150K [M]	R1315	ERDS2TJ101	1/4W 100 [M]	C107	ECBT1H473ZF5	50V 0.047U [M]
R1045	ERDS2TJ682T	1/4W 6.8K [M]	R1316	ERDS2TJ102	1/4W 1K [M]	C108	ECBT1H100JC5	50V 10P [M] (E, EB)
R1046	ERG1SJ680	1W 68 [M]	R1317	ERDS2TJ221	1/4W 220 [M]	C108	ECBT1H8R2KC5	50V 8.2P [M] (EG)
R1047, 1048	ERDS2TJ184T	1/4W 180K [M]	R1318	ERDS2TJ101	1/4W 100 [M]	C109, 110	ECBT1C103NS5	16V 0.01U [M]
R1049	ERDS1FJ270	1/2W 27 [M]△	R1319	ERDS2TJ221	1/4W 220 [M]	C111	ECEA1EKA4R7B	25V 4.7U [M]
R1050	ERDS2TJ154	1/4W 150K [M]	R1320	ERDS2TJ750	1/4W 75 [M]	C112	ECBT1C103NS5	16V 0.01U [M]
R1051, 1052	ERDS2TJ682T	1/4W 6.8K [M]	R1321-1323	ERDS2TJ473	1/4W 47K [M]	C113	ECBT1H102KB5	50V 1000P [M]
R1053, 1054	ERDS1FJ222	1/2W 2.2K [M]△	R1401	ERDS2TJ331	1/4W 330 [M]	C114	RCE1HKA3R3BG	50V 3.3 [M]
R1055, 1056	ERDS2TJ222	1/4W 2.2K [M]	R1402, 1403	ERDS2TJ224T	1/4W 220K [M]	C115	ECEA1EKA4R7B	25V 4.7U [M]
R1057-1060	ERD2FCVJ4R7T	1/4W 4.7 [M]△	R1404-1408	ERDS2TJ103	1/4W 10K [M]	C116	ECBT1C822MS5	16V 8200P [M]
R1061-1067	ERDS2TJ223	1/4W 22K [M]	R1409, 1410	ERDS2TJ332	1/4W 3.3K [M]	C117	ECQB1H471JF3	50V 470P [M]
R1068	ERDS2TJ124T	1/4W 120K [M]	R1411	ERDS2TJ103	1/4W 10K [M]	C118, 119	ECQB1H103JF3	50V 0.01U [M]
R1069	ERDS2TJ474	1/4W 470K [M]	R1412	ERDS2TJ101	1/4W 100 [M]	C120, 121	ECEA1HKA010B	50V 1U [M]
R1070	ERDS2TJ102	1/4W 1K [M]	R1413, 1414	ERDS2TJ103	1/4W 10K [M]	C122	ECEA1HKA2R2B	50V 2.2U [M]
R1071	ERDS1FJ270	1/2W 27 [M]△	R1415	ERDS2TJ100	1/4W 10 [M]	C123	ECEA1HKA010B	50V 1U [M]
R1072	ERDS2TJ102	1/4W 1K [M]	R1416	ERDS2TJ182	1/4W 1.8K [M]	C124	ECBT1H102KB5	50V 1000P [M]
R1073	ERDS1FJ270	1/2W 27 [M]△	R1417	ERDS2TJ750	1/4W 75 [M]	C125	ECBT1H150JC5	50V 15P [M]
R1074, 1075	ERDS2TJ102	1/4W 1K [M]	R1418	ERDS2TJ471	1/4W 470 [M]	C126	ECBT1H104ZF5	50V 0.1U [M]
R1076	ERG1SJ680	1W 68 [M]	R1419	ERDS2TJ750	1/4W 75 [M]	C127	ECEA1CKA220B	16V 22U [M]
R1077	ERDS1FJ270	1/2W 27 [M]△	R1420	ERDS2TJ101	1/4W 100 [M]	C128	ECBT1C103NS5	16V 0.01U [M]
R1078	ERDS2TJ332	1/4W 3.3K [M]	R1421	ERDS2TJ473	1/4W 47K [M]	C129, 130	ECEA0JKA101B	6.3V 100U [M]
R1080-1085	ERDS2TJ100	1/4W 10 [M]	R1422	ERDS2TJ471	1/4W 470 [M]	C131	ECBT1C103NS5	16V 0.01U [M]
R1086	ERDS2TJ223	1/4W 22K [M]	R1423	ERDS2TJ123	1/4W 12K [M]	C132	ECBT1H102KB5	50V 1000P [M]
R1087	ERDS2TJ274	1/4W 270K [M]	R1424	ERDS2TJ103	1/4W 10K [M]	C133, 134	ECBT1H270JU5	50V 27P [M]
R1089, 1090	ERD25FVJ221T	1/4W 220 [M]△	R1425	ERDS2TJ472	1/4W 4.7K [M]	C135, 136	ECBT1C103KS5	16V 0.01U [M]
R1091, 1092	ERDS1FVJ100T	1/2W 10 [M]△	R1426	ERDS2TJ101	1/4W 100 [M]	C137, 138	ECBT1H561KB5	50V 560P [M]
R1093-1095	ERD25FVJ221T	1/4W 220 [M]△	R1427	ERDS2TJ100	1/4W 10 [M]	C139, 140	ECQB1H682JF3	50V 6800P [M]
R1096-1099	ERDS1FVJ100T	1/2W 10 [M]△	R1428	ERDS2TJ471	1/4W 470 [M]	C141-144	ECEA1HKA010B	50V 1U [M]
R1101, 1102	ERDS2TJ104	1/4W 100K [M]	R1429	ERDS2TJ182	1/4W 1.8K [M]	C145	ECBT1H220JC5	50V 22P [M]
R1103, 1104	ERDS2TJ103	1/4W 10K [M]	R1430	ERDS2TJ750	1/4W 75 [M]	C147	ECBT1H102KB5	50V 1000P [M]
R1105, 1106	ERDS2TJ562	1/4W 5.6K [M]	R1431	ERDS2TJ223	1/4W 22K [M]	C148, 149	ECBT1C103NS5	16V 0.01U [M]
R1107, 1108	ERDS2TJ102	1/4W 1K [M]	R1432	ERDS2TJ473	1/4W 47K [M]	C150	ECBT1H104ZF5	50V 0.1U [M]
R1109-1112	ERDS2TJ103	1/4W 10K [M]	R1433	ERDS2TJ101	1/4W 100 [M]	C172	ECBT1H331KB5	50V 330P [M]
R1113-1116	ERDS2TJ331	1/4W 330 [M]	R1434	ERDS2TJ102	1/4W 1K [M]	C173	ECEA1CKA220B	16V 22U [M]
R1117	ERDS2TJ182	1/4W 1.8K [M]	R1501, 1502	ERDS1FJ270	1/2W 27 [M]△	C174	ECEA1CKA101B	16V 100U [M]
R1121	ERDS2TJ103	1/4W 10K [M]	R1503-1506	ERG1SJ680	1W 68 [M]	C175, 176	ECBT1C103NS5	16V 0.01U [M]
R1131	ERDS2TJ106T	1/4W 10M [M]	R1507, 1508	ERDS2TJ153	1/4W 15K [M]	C181	ECBT1H471KB5	50V 470P [M]
R1132	ERDS2TJ122	1/4W 1.2K [M]	R1509, 1510	ERDS2TJ682T	1/4W 6.8K [M]	C196	ECBT1H102KB5	50V 1000P [M]
R1151-1153	ERDS2TJ822	1/4W 8.2K [M]	R1511, 1512	ERDS2TJ153	1/4W 15K [M]	C201	ECBT1E223ZF	25V 0.022U [M]
R1154	ERDS2TJ103	1/4W 10K [M]	R1513, 1514	ERDS2TJ682T	1/4W 6.8K [M]	C202	ECBT1E103ZF	25V 0.01U [M]
R1155, 1156	ERDS2TJ822	1/4W 8.2K [M]	R1515	ERDS2TJ153	1/4W 15K [M]			

Ref. No.	Part No.	Values & Remarks	Ref. No.	Part No.	Values & Remarks	Ref. No.	Part No.	Values & Remarks
C302, 303	RCE1CKA100BG	16V 10U [M]	C529, 530	ECBT1H561KB5	50V 560P [M]	C712	RCE1CKA100BG	16V 10U [M]
C311	ECBT1H101KB5	50V 100P [M]	C531, 532	ECBT1H101KB5	50V 100P [M]	C713, 714	ECBT1E103ZF	25V 0.01U [M]
C312	ECEA1EKA4R7B	25V 4.7U [M]	C533, 534	ECBT1H271KB5	50V 270P [M]	C715	ECKR1H103ZF5	50V 0.01U [M]
C313	ECBT1E103ZF	25V 0.01U [M]	C535-538	ECKT1H223ZF	50V 0.022U [M]	C716, 717	ECEA1VKA470B	35V 47U [M]
C314	ECEA1EKA4R7B	25V 4.7U [M]	C581	ECBT1E223ZF	25V 0.022U [M]	C719, 720	ECA1VM332E	35V 3300U [M]△
C315	ECBT1E103ZF	25V 0.01U [M]	C601, 602	RCE1CKA100BG	16V 10U [M]	C722, 723	ECES1K752VJX	75V 7500U [M]△
C317-320	ECBT1H151KB5	50V 150P [M]	C603	RCE1HKA3R3BG	50V 3.3U [M]	C724	RCE1AKA101BG	10V 100U [M]
C321	ECBT1E103ZF	25V 0.01U [M]	C604	RCE1HKAR47BG	50V 0.47U [M]	C725, 726	ECQE2104KF3	250V 0.1U [M]
C350	ECBT1C152KR5	16V 1500P [M]	C605-609	RCE1HKA3R3BG	50V 3.3U [M]	C727	ECBT1E103ZF	25V 0.01U [M]
C351	ECEA1HKA2R2B	50V 2.2U [M]	C610	RCE1HKAR47BG	50V 0.47U [M]	C728	RCE1CKA470BG	16V 47U [M]
C352, 353	ECEA1EKN3R3B	25V 3.3U [M]	C611, 612	RCE1HKA3R3BG	50V 3.3U [M]	C729	ECA1EM102E	25V 1000U [M]△
C354	ECBT1C152KR5	16V 1500P [M]	C613-615	RCE1CKA100BG	16V 10U [M]	C730	ECEA1HKA2R2B	50V 2.2U [M]
C355	ECEA1HKA2R2B	50V 2.2U [M]	C616-618	ECBT1H104ZF5	50V 0.1U [M]	C731	ECKR1H103ZF5	50V 0.01U [M]
C356, 357	RCE1CM102BV	16V 1000U [M]	C619-621	RCE1CKA100BG	16V 10U [M]	C732	ECBT1E223ZF	25V 0.022U [M]
C401-416	ECBT1H151KB5	50V 150P [M]	C622-627	ECBT1H104ZF5	50V 0.1U [M]	C733	ECKWR5102MBC	400V 1000P [M]△
C417-420	ECEA1EKA4R7B	25V 4.7U [M]	C628-630	RCE1CKA100BG	16V 10U [M]	C734	ECEA0JKA221B	6.3V 220U [M]
C421-424	ECBT1E103ZF	25V 0.01U [M]	C631-634	ECBT1H104ZF5	50V 0.1U [M]	C735	RCE1CKA100BG	16V 10U [M]
C425-428	ECBT1H101KB5	50V 100P [M]	C635	RCE1HKA3R3BG	50V 3.3U [M]	C737	ECBT1E103ZF	25V 0.01U [M]
C429, 430	RCE1CKA100BG	16V 10U [M]	C636	RCE1HKAR47BG	50V 0.47U [M]	C744	ECEA1CKA220B	16V 22U [M]
C431, 432	ECBT1E103ZF	25V 0.01U [M]	C637, 638	RCE1HKA3R3BG	50V 3.3U [M]	C801	ECBT1E103ZF	25V 0.01U [M]
C433, 434	ECEA1CKA220B	16V 22U [M]	C639, 640	ECEA1CKA220B	16V 22U [M]	C802, 803	ECA2AM100B	100V 10U [M]
C435, 436	ECBT1H151KB5	50V 150P [M]	C641	ECBT1H221KB5	50V 220P [M]	C804	ECBT1H320KB5	50V 82P [M]
C438	ECEA1HKA010B	50V 1U [M]	C642	ECBT1E223ZF	25V 0.022U [M]	C805	ECBT1H102KB5	50V 1000P [M]
C440	ECBT1H104ZF5	50V 0.1U [M]	C643, 644	ECBT1H181KB5	50V 180P [M]	C806	ECBT1H151KB5	50V 150P [M]
C441	RCE1CKA100BG	16V 10U [M]	C645, 646	ECBT1H221KB5	50V 820P [M]	C807	ECEA1CKA220B	16V 22U [M]
C442	RCE1HKS010BV	50V 1U [M]	C647	ECBT1C122KR5	16V 1200P [M]	C808	ECBT1H151KB5	50V 150P [M]
C444	ECBT1H104ZF5	50V 0.1U [M]	C648	ECBT1H104ZF5	50V 0.1U [M]	C809	ECEA1CKA220B	16V 22U [M]
C445	RCE1CKA100BG	16V 10U [M]	C649, 650	ECBT1H101KB5	50V 100P [M]	C810	ECBT1H151KB5	50V 150P [M]
C446	ECBT1E103ZF	25V 0.01U [M]	C653, 654	ECBT1H101KB5	50V 100P [M]	C811	ECEA1CKA220B	16V 22U [M]
C450	ECBT1H104ZF5	50V 0.1U [M]	C655, 656	ECBT1C152KR5	16V 1500P [M]	C812	ECBT1H151KB5	50V 150P [M]
C451	RCE1CKA100BG	16V 10U [M]	C657, 658	ECBT1H101KB5	50V 100P [M]	C813, 814	ECA1JM330B	63V 33U [M]
C452	ECEA0JKA101B	6.3V 100U [M]	C659	ECBT1H221KB5	50V 820P [M]	C815	ECEA1CKA220B	16V 22U [M]
C453	ECEA0JKA221B	6.3V 220U [M]	C660	ECBT1E103ZF	25V 0.01U [M]	C816, 817	ECBT1H102KB5	50V 1000P [M]
C454, 455	ECFR1E104KR	25V 0.1U [M]	C661, 662	ECBT1H101KB5	50V 100P [M]	C818	ECBT1H151KB5	50V 150P [M]
C458	ECBT1H104ZF5	50V 0.1U [M]	C663, 664	ECBT1H102KB5	50V 1000P [M]	C819	ECEA1CKA220B	16V 22U [M]
C459	ECEA0JKA221B	6.3V 220U [M]	C666	ECBT1H104ZF5	50V 0.1U [M]	C820	ECBT1E103ZF	25V 0.01U [M]
C501, 502	RCE1CKA470BG	16V 47U [M]	C667, 668	ECBT1C152KR5	16V 1500P [M]	C821	ECBT1H151KB5	50V 150P [M]
C503, 504	ECBT1C562KR5	16V 5600P [M]	C669	ECBT1C122KR5	16V 1200P [M]	C822	ECEA1CKA220B	16V 22U [M]
C505, 506	ECBT1H221KB5	50V 220P [M]	C671, 672	ECEA1CKA220B	16V 22U [M]	C823	ECBT1H151KB5	50V 150P [M]
C507, 508	ECBT1H101KB5	50V 100P [M]	C673	ECBT1H104ZF5	50V 0.1U [M]	C824	ECEA1CKA220B	16V 22U [M]
C509, 510	ECEA1CKN4R7B	16V 4.7U [M]	C675, 676	ECBT1H331KB5	50V 330P [M]	C825	ECBT1H151KB5	50V 150P [M]
C511, 512	ECEA1EKA4R7B	25V 4.7U [M]	C678	ECBT1H331KB5	50V 330P [M]	C826	ECEA1CKA220B	16V 22U [M]
C513, 514	ECBT1E103ZF	25V 0.01U [M]	C681	ECA1VM221B	35V 220U [M]	C827	ECBT1H151KB5	50V 150P [M]
C515, 516	ECQV1H683JM3	50V 0.068U [M]	C697, 698	RCE1CKA100BG	16V 10U [M]	C828	ECEA1CKA220B	16V 22U [M]
C517, 518	ECFR1C123KR	16V 0.012U [M]	C701	ECEA0JKA101B	6.3V 100U [M]	C829	ECBT1H151KB5	50V 150P [M]
C519, 520	ECBT1C272KR5	16V 2700P [M]	C702	RCE1CKA100BG	16V 10U [M]	C830	ECEA1CKA220B	16V 22U [M]
C521, 522	ECFR1C223KR	16V 0.022U [M]	C703, 704	ECEA1VKA470B	35V 47U [M]	C831	ECBT1H151KB5	50V 150P [M]
C523	RCE1HKS3R3BV	50V 3.3U [M]	C705	ECBT1E103ZF	25V 0.01U [M]	C832	ECEA1CKA220B	16V 22U [M]
C524	RCE1HKA3R3BG	50V 3.3U [M]	C706	ECEA1EKA100B	25V 10U [M]	C833-836	ECEA0JKA101B	6.3V 100U [M]
C525	ECEA1CKS220	16V 22U [M]	C708	ECBT1E103ZF	25V 0.01U [M]	C837-840	ECEA1EKN3R3B	25V 3.3U [M]
C526	ECEA1CKA220B	16V 22U [M]	C709	ECEA1CKA101B	16V 100U [M]	C841	ECBA1H581KB5	50V 680P [M]
C527, 528	RCE1AKA330BG	10V 33U [M]	C711	ECA1EM472E	25V 4700U [M]△	C842	ECEA1EKN3R3B	25V 3.3U [M]

Ref. No.	Part No.	Values & Remarks	Ref. No.	Part No.	Values & Remarks	Ref. No.	Part No.	Values & Remarks
C843-845	ECBA1H681KB5	50V 680P [M]	C938	ECBT1H101KB5	50V 100P [M]	C1208	RCE1CKA100BG	16V 10U [M]
C847	ECBT1H271KB5	50V 270P [M]	C939	ECBT1E103ZF	25V 0.01U [M]	C1210	ECBT1E103ZF	25V 0.01U [M]
C848	ECBA1H681KB5	50V 680P [M]	C940, 941	ECBT1H331KB5	50V 330P [M]	C1212-1214	ECBT1H101KB5	50V 100P [M]
C849	ECA1JM330B	63V 33U [M]	C1001-1005	ECEA1CKA220B	16V 22U [M]	C1218	ECBT1H102KB	50V 1000P [M]
C850, 851	ECA1JM470B	63V 47U [M]	C1101, 1102	RCE1CKA100BG	16V 10U [M]	C1219	ECCT1H181K	50V 180P [M]
C852, 853	ECBA1H681KB5	50V 680P [M]	C1103, 1104	ECBT1C222KR5	16V 2200P [M]	C1220	ECBT1H390J5	50V 39P [M]
C854, 855	ECCD1H150KC	50V 15P [M]	C1106	RCE1CKA100BG	16V 10U [M]	C1221, 1222	ECBT1H104ZF5	50V 0.1U [M]
C856	ECA1JM330B	63V 33U [M]	C1107-1109	ECBT1H104ZF5	50V 0.1U [M]	C1223	ECBT1C152KR5	16V 1500P [M]
C857-859	ECBA1H681KB5	50V 680P [M]	C1110	ECEA1EKA4R7B	25V 4.7U [M]	C1224	ECBT1E103ZF	25V 0.01U [M]
C860	ECA1JM470B	63V 47U [M]	C1111, 1112	ECBT1H104ZF5	50V 0.1U [M]	C1226	ECBT1H101KB5	50V 100P [M]
C861	ECBA1H681KB5	50V 680P [M]	C1113	RCE1CKA100BG	16V 10U [M]	C1301-1303	ECEA1HKA2R2B	50V 2.2U [M]
C862, 863	ECA1JM470B	63V 47U [M]	C1115	ECBT1H104ZF5	50V 0.1U [M]	C1304	ECEA1HKS2R2B	50V 2.2U [M]
C864-866	ECCD1H150KC	50V 15P [M]	C1116	RCE1CKA100BG	16V 10U [M]	C1305	ECEA0GKA471B	4V 470U [M]
C867, 868	ECBA1H681KB5	50V 680P [M]	C1117-1119	ECBT1H104ZF5	50V 0.1U [M]	C1306-1309	ECEA1HKS2R2B	50V 2.2U [M]
C869	ECBT1H102KB5	50V 1000P [M]	C1121	ECEA0JKA101B	6.3V 100U [M]	C1310	ECA0JM471B	6.3V 470U [M]
C870	ECR1H103ZF5	50V 0.01U [M]	C1122, 1123	ECBT1H104ZF5	50V 0.1U [M]	C1311	ECBT1H102KB5	50V 1000P [M]
C871	ECA1JM220B	63V 22U [M]	C1124	ECEA0JKA101B	6.3V 100U [M]	C1312-1314	ECBT1E103ZF	25V 0.01U [M]
C873	ECEA2AN2R2SB	100V 2.2U [M]	C1125-1127	ECBT1H104ZF5	50V 0.1U [M]	C1315-1317	ECEA0JKA470B	6.3V 47U [M]
C875	ECBT1H102KB5	50V 1000P [M]	C1128	ECA0JM102B	6.3V 1000U [M]	C1318-1320	ECEA1HKA2R2B	50V 2.2U [M]
C876-880	ECQV1H473JM3	50V 0.047U [M]	C1129, 1130	ECBT1H104ZF5	50V 0.1U [M]	C1401	ECEA1HKA2R2B	50V 2.2U [M]
C881	ECA1HM101B	50V 100U [M]	C1131	ECBT1H330J5	50V 33P [M]	C1402	RCE1CKA100BG	16V 10U [M]
C882	ECEA1HKA010B	50V 1U [M]	C1132	ECBT1H120J5	50V 12P [M]	C1403	ECEA1CKS100L	16V 10U [M]
C883-887	ECCT1H223ZF	50V 0.022U [M]	C1133	ECA0JM102B	6.3V 1000U [M]	C1404	RCE1CKA100BG	16V 10U [M]
C888	ECBT1E103ZF	25V 0.01U [M]	C1134, 1135	ECBT1H104ZF5	50V 0.1U [M]	C1405	ECEA0JKA101B	6.3V 100U [M]
C889, 890	ECRT1H223ZF	50V 0.022U [M]	C1136, 1137	ECA0JM102B	6.3V 1000U [M]	C1406	ECBT1E103ZF	25V 0.01U [M]
C892, 893	ECBT1H102KB5	50V 1000P [M]	C1138, 1139	ECBT1H104ZF5	50V 0.1U [M]	C1407	ECA0JM471B	6.3V 470U [M]
C894-897	ECA2AM100B	100V 10U [M]	C1140, 1141	ECA0JM471B	6.3V 470U [M]	C1408	ECEA0JKA101B	6.3V 100U [M]
C898	ECQV1H154JM3	50V 0.15U [M]	C1144, 1145	ECA0JM471B	6.3V 470U [M]	C1409	ECBT1E103ZF	25V 0.01U [M]
C901-903	ECBT1H101KB5	50V 100P [M]	C1147	ECA0JM471B	6.3V 470U [M]	C1410-1412	ECBT1H102KB5	50V 1000P [M]
C904, 905	ECBT1E103ZF	25V 0.01U [M]	C1148	ECBT1H104ZF5	50V 0.1U [M]	C1413	ECBT1E103ZF	25V 0.01U [M]
C906, 907	ECBT1H101KB5	50V 100P [M]	C1151-1154	ECBA1H681KB5	50V 680P [M]	C1414	ECBT1H180J5	50V 18P [M]
C908, 909	ECA2AM100B	100V 10U [M]	C1155, 1156	ECBT1C272KR5	16V 2700P [M]	C1415	ECA0JM471B	6.3V 470U [M]
C910	ECBT1E103ZF	25V 0.01U [M]	C1157-1160	ECBT1C152KR5	16V 1500P [M]	C1416, 1417	ECBT1H220J5	50V 22P [M]
C911	RCE1VKA100BG	35V 10U [M]	C1161, 1162	ECBT1C682KR5	16V 6800P [M]	C1418	ECBT1E103ZF	25V 0.01U [M]
C912	ECBT1H101KB5	50V 100P [M]	C1163-1166	ECBT1H101KB5	50V 100P [M]	C1419	ECBT1H470J5	50V 47P [M]
C913	ECBT1E103ZF	25V 0.01U [M]	C1167, 1168	ECBT1H561KB5	50V 560P [M]	C1420	ECBT1E103ZF	25V 0.01U [M]
C914	RCE1VKA100BG	35V 10U [M]	C1169-1171	ECBT1H104ZF5	50V 0.1U [M]	C1421	ECEA0JKA101B	6.3V 100U [M]
C915, 916	ECBT1E103ZF	25V 0.01U [M]	C1172-1174	ECEA0JKA101B	6.3V 100U [M]	C1422	ECBT1E103ZF	25V 0.01U [M]
C917	ECA0JM102B	6.3V 1000U [M]	C1175-1177	ECBT1H104ZF5	50V 0.1U [M]	C1423	ECEA0JKA101B	6.3V 100U [M]
C918	ECEA1HKA010B	50V 1U [M]	C1178, 1179	ECBT1H390J5	50V 39P [M]	C1424	ECBT1H101KB5	50V 100P [M]
C919	ECBT1E103ZF	25V 0.01U [M]	C1180	ECBT1E103ZF	25V 0.01U [M]	C1425	ECBT1E103ZF	25V 0.01U [M]
C920	ECEA0JKA101B	6.3V 100U [M]	C1181-1183	RCE1CKA100BG	16V 10U [M]	C1426-1428	ECBT1H101KB5	50V 100P [M]
C921	ECEA1HKA010B	50V 1U [M]	C1184-1186	ECBT1H104ZF5	50V 0.1U [M]	C1429	ECBT1C105ZF5	16V 1U [M]
C922	ECA0JM471B	6.3V 470U [M]	C1187-1189	ECBT1H101KB5	50V 100P [M]	C1430, 1431	ECBT1H101KB5	50V 100P [M]
C923	ECBT1H101KB5	50V 100P [M]	C1190	ECBT1H181KB5	50V 180P [M]	C1448-1450	ECBT1E103ZF	25V 0.01U [M]
C924-930	ECBT1H331KB5	50V 330P [M]	C1193-1195	RCE1CKA100BG	16V 10U [M]			
C931	ECEA0JKA101B	6.3V 100U [M]	C1196-1200	ECBT1H104ZF5	50V 0.1U [M]			
C932	ECBT1H104ZF5	50V 0.1U [M]	C1201	ECEA0JKA101B	6.3V 100U [M]			
C933	RCE1CKA100BG	16V 10U [M]	C1202	ECA0JM102B	6.3V 1000U [M]			
C934	ECBT1E103ZF	25V 0.01U [M]	C1203	ECBT1H104ZF5	50V 0.1U [M]			
C935, 936	ECBT1H104ZF5	50V 0.1U [M]	C1204, 1205	RCE1CKA100BG	16V 10U [M]			
C937	RCE1CKA100BG	16V 10U [M]	C1206, 1207	RCE1HKA3R3BG	50V 3.3U [M]			

Replacement Parts List (Packing, Accessories)

Notes:

- * Important safety notice: Components identified by Δ mark have special characteristics important for safety. Furthermore, special parts which have purposes of fire-retardant (resistors), high-quality sound (capacitors), low-noise (resistors), etc. are used. When replacing any of components, be sure to use only manufacturer's specified parts shown in the parts list.
- * The parenthesized indications in the Remarks columns specify the areas. (Refer to the cover page for area.) Parts without these indications can be used for all areas.
- * Remote Control Assy: Supply period for three years from termination of production.
- * The "(SF)" mark denotes the standard part.
- * [M] indicates in Remarks columns parts that are supplied by MESA.

Ref. No.	Part No.	Part Name & Description	Remarks	Ref. No.	Part No.	Part Name & Description	Remarks
		PACKING MATERIAL		A2	RJA0049-K	AC POWER SUPPLY CORD	[M] (EB) Δ
P1	RPG3466	PACKING CASE	[M]	A3	RAK-SA746WH	REMOTE CONTROL TRANSMITTER	[M]
P2	RPN0982	CUSHION	[M]	A3-1	RRK0020-K	BATTERY COVER FOR R. C. T.	[M]
P3	RPF0139	PROTECTION BAG (F. B.)	[M]	A4	RQA0117	WARRANTY CARD	[M]
P4	SPP730	PROTECTION BAG (UNIT)	[M]	A5	RQCB0169	SERVICENTER LIST	[M]
P5	RPH0032	PROTECTION SHEET	[M] (EB)	A6	RSA0007	FM INDOOR ANTENNA	[M]
		ACCESSORIES		A7	RSA0010	AM LOOP ANTENNA SET	[M]
A1	RQT3940-B	INSTRUCTION MANUAL	[M] (E, EB) <IA>	A7-1	FMN0244	AM ANTENNA HOLDER	[M]
A1	RQT3941-R	INSTRUCTION MANUAL	[M] (E) <IB>	A7-2	XIN3+12AFZ	SCREW	[M]
A1	RQT3942-D	INSTRUCTION MANUAL	[M] (EG) <IC>	A8	SJP9009	ATTACHMENT PLUG	[M] (EB) Δ
A1	RQT3943-H	INSTRUCTION MANUAL	[M] (EG) <ID>			<GREASE OR JIG/TOOL>	
A2	RJA0019-2K	AC POWER SUPPLY CORD	[M] (E, EG) Δ (SF)			GREASE	
				SA1	RFK0002	COMPOUND GREASE	[M]
				SA2	RFKZ0013	EXTENSION CABLES	[M]

Note: The "< IA >, < IB >, < IC >, < ID >" marks in Remarks indicate language of instruction manual.

- < IA > : English, Spanish, Swedish
- < IB > : Polish, Czech, Russian
- < IC > : German, Italy, French
- < ID > : Dutch, Danish

Packaging

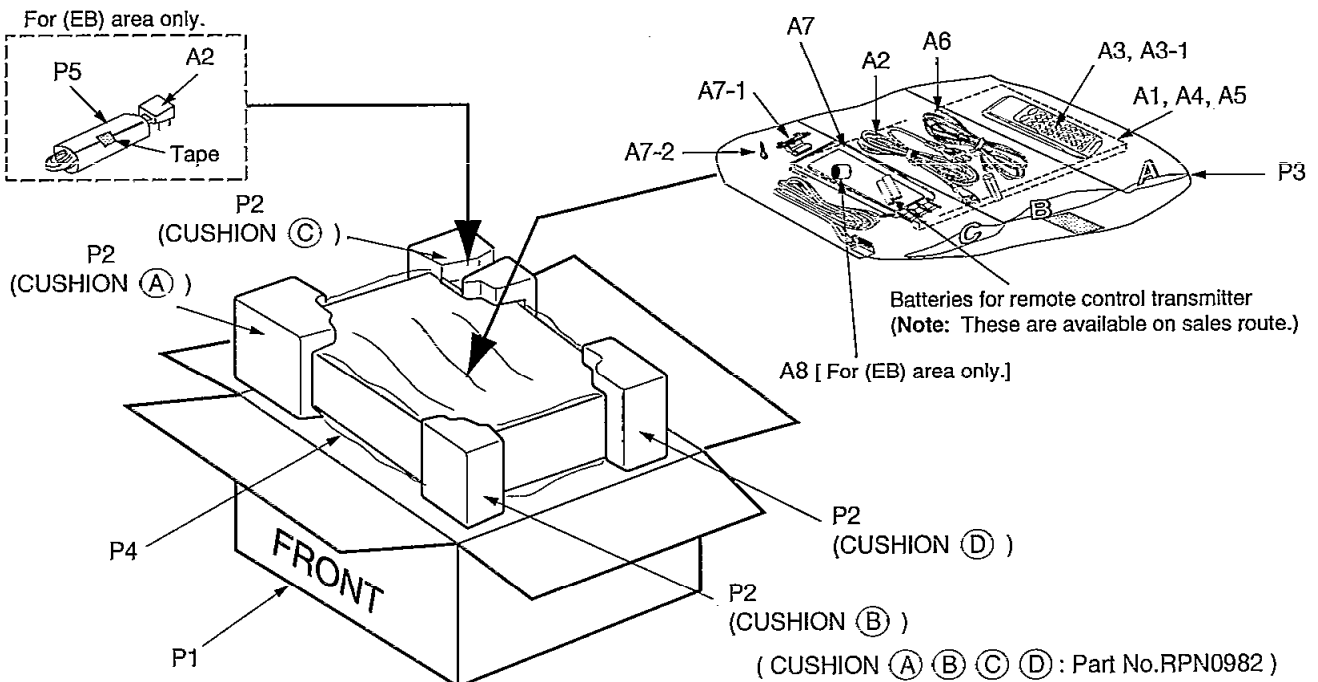

MEMO

060